

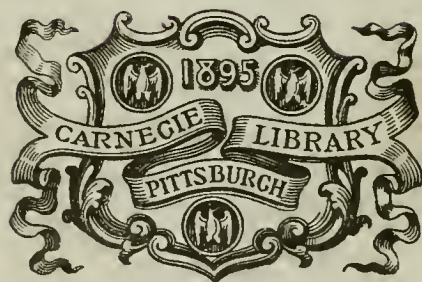

Class

Book









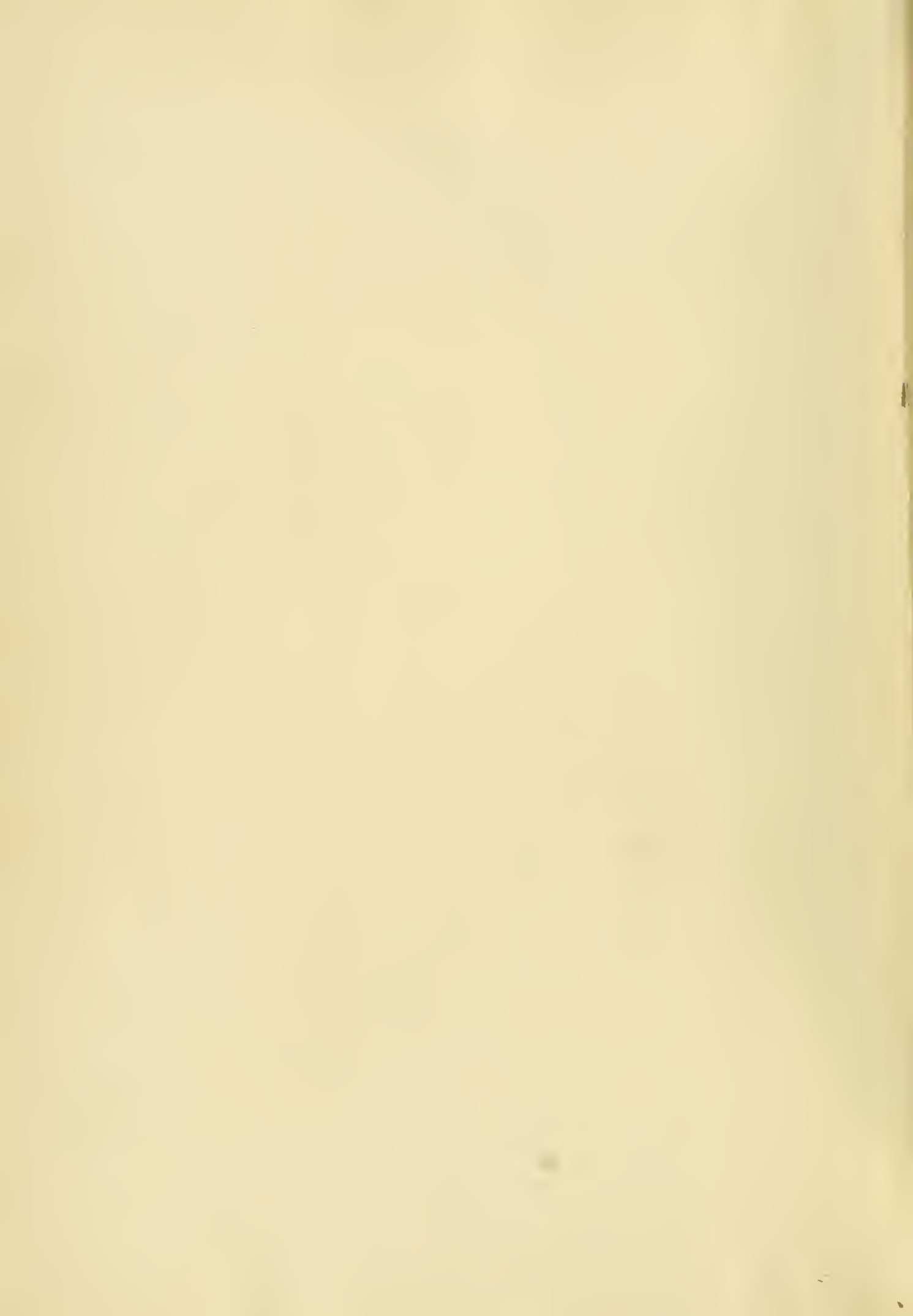











# Railway Age Gazette

MECHANICAL EDITION

INCLUDING THE  
AMERICAN ENGINEER

Established 1832

## INDEX TO VOLUME LXXXVIII 1914

ALSO OF THE

DAILY RAILWAY AGE GAZETTE

ISSUED DURING THE

M. M. AND M. C. B. CONVENTIONS

3460

# INDEX, 1914

## VOLUME LXXXVIII

### A

Accidents, Excessive speed and.....	4†
Accidents, Railway.....	166‡
Accidents, Railway, and their causes.....	16
Acetylene generator, Vulcan.....	1312*
Acme Supply Co., Gem and Crown curtain fixtures.....	1313
Acme Supply Co., Kass safety step.....	1382*
Acme Supply Co., Steel door for baggage car	1403
Africa, Cape to Cairo Railway.....	39†
Agasote.....	1403†
Ahsiuoh, N. H., Autogenous welding in locomotive fireboxes.....	149*
Ahsiuoh, N. H., Crown sheet expansion stays	375*
Ahsiuoh, N. H., Firebox riveting.....	191*
Air brake appliance, Safety.....	47*
Air Brake Association (see also Meetings).	
Air brake efficiency.....	303
Air brake hose, by T. W. Dow.....	302
Air brake, Maintenance of the, Report at General Foremen's convention.....	412
Air compressor.....	1478*
Air compressor, Angle compound power driven, Sullivan.....	259*
Air compressor, Cross compound for the Lackawanna.....	208*
Air compressor, Direct oil driven, Ingersoll-Rand Co.....	383*
Air compressor, Rotary.....	597*
Air hose protector.....	153*
Air gate, The caboose.....	301
Air meter, High pressure volumetric.....	331*
Air motors for light drilling.....	434*
Air motors, Right angle attachment for.....	143*
Air pump, Burning out oil deposits in, Ill. Cent.....	538*
Air pump governors, Tools for repairing, L. & N.....	373*
Air pump piston swab.....	1477*
Allen, A. J., Painting steel cars.....	527
Allman, William N., Strength of locomotive boilers.....	123*, 225†
Alloy steel, Use of.....	47†
Aluminum, Production of.....	640†
American Abrasive Metals Co., Wheel truing brake shoe.....	269*
American Boiler Manufacturers' Association (see also Meetings).	
American Car Roof Co., Christy steel freight car roof.....	261*
American Car Roof Co., Corrugated steel door with fender attachment.....	547*
American Flexible Staybolt Co., American staybolt.....	1477*
American Foundrymen's Association and American Institute of Metals (see also Meetings).	
American Gas Furnace Co., Casehardening with gas.....	492*
American Locomotive Co., Boiler shop methods.....	637*
American Locomotive Co., C. & O. 4-6-2 type Locomotive.....	614*
American Metal Co., Bronze bearing metal for truck journals.....	324
American Railway Master Mechanics' Association (see Master Mechanics' Association).	
American Railway Tool Foremen's Association (see Tool Foremen's Association).	
American Railway Tool Foremen's Association (see also Meetings).	
American Society for Testing Materials (see also Meetings).	
American Society of Mechanical Engineers (see also Meetings).	
American Tool Works Co., Heavy service shaper.....	327*
Ann Arbor Railroad, Locomotive fire door.....	104*
Apprentice instruction, Notes on, by H. E. Blackburn.....	31*
Apprentice material, by A. B. Kerr.....	319
Apprentice schools, Observations on.....	373
Apprentice system, Paint shop, D. L. & W.....	529
Apprentice, The, a boy, by A. B. Kerr.....	150
Apprentice, The special.....	504†
Appropriations, Mechanical department.....	611‡
Armstrong, H. W., Chemical treatment of feed water.....	316
Armstrong Cork & Insulating Co., Heat insulating brick.....	1504†

Armstrong, George W., General machine tool efficiency.....	255*
Armstrong, L. N., Electro-pneumatic signal system.....	302
Articles on car work.....	1‡
Ash Pan Act, Violations of the.....	22†
Ash pans, air openings of.....	284*
Ash pan levers, Dies for forming bosses on, P. R. K.....	639*
Ashton Valve Co., Air pump piston swab.....	1477*
Atchison, Topeka & Santa Fe, Safety baggage rack.....	646*
Atchison, Topeka & Santa Fe, Testing car roofs for leakage.....	374*
Atlantic Coast Line, Frictionless return roller side bearing.....	384*
Atlantic Coast Line, Grinding exhaust nozzles.....	322*
Atlantic Coast Line, Improved tool holder and center for wheel lathe.....	142*
Atlantic Coast Line, Machining pistons on a vertical turret lathe.....	92*
Atlantic Coast Line, Reclaiming cast steel driving boxes.....	375*
Atlantic Coast Line, Welding practice on.....	585*
Austin trailing truck.....	382*
Australia, American locomotives for.....	270†
Autogenous welding, Report at General Foremen's convention.....	583*
Automatic couplers in Europe.....	606†
Axle generator suspension.....	1382*
Axle, Study of an internal transverse fissure in a failed.....	405*
Axles, Reclaiming, on the Erie.....	644*

### B

Baggage rack, Safety, Santa Fe.....	646*
Baker Brothers, High speed drill.....	153*
Baldwin, J. H., Adjustable pliers.....	331*
Baldwin Locomotive Works, Locomotive, 2-10-2 type, B. & O.....	456*
Baldwin Locomotive Works, Locomotive, 2-8-8-2 type, Erie.....	227*
Ball bearings on turntables.....	329*
Baltimore & Ohio, Jig for drilling cross-head shoes.....	320*
Baltimore & Ohio locomotive, 2-10-2 type.....	456*
Baltimore & Ohio, Locomotive front ends, 1853-1913.....	617*
Baltimore & Ohio, Milk refrigerator also machine saw, Metal cutting (see also Machine tools).	621*
Baltimore & Ohio, Painting steel cars.....	527
Bangor & Aroostook, Passenger coach with roller bearings.....	19*
Barnes Drill Co., Geared drill.....	48*
Barnum, M. K., Address at Master Car Builders' Association convention.....	1289*
Barnum, M. K., College men in railroad work	73
Basford, George M., Development of young men in railroad work.....	69
Baxter, H. M., Buying brushes on specifications.....	128
Bayless, H. C., Address at T. E. A. convention.....	505
Bearings, Roller on coaches.....	2‡
Beaudry & Co., Inc., Motor drive for hammers.....	44*
Benjamin, C. H., College men and the railroads.....	62†
Bentley, F. W., Jr., Clips for holding brake cylinder head gaskets.....	380*
Bentley, F. W., Jr., Combination tool for repairing E-T distributing valves.....	418*
Bentley, F. W., Jr., Dial rims for adjusting gage hands.....	92*
Bentley, F. W., Jr., Jig for grinding in rotary valves on E-T equipment.....	115†
Bentley, F. W., Jr., Portable combination test rack.....	378*
Bentley, F. W., Jr., Roundhouse test rack for examining lubricators.....	152*
Berg, R. M., Safety appliance standards.....	576
Betton, J. M., Sand blast for cleaning steel cars.....	17*
Blackburn, H. E., Fuel oil burner.....	253*
Blackburn, H. E., Notes on apprentice instruction.....	31*
Blackburn, H. F., Portable tire heater.....	94*
Blake, R. P., The greatest weakness in box cars.....	630

Blueprint marking fluid.....	587†
Blueprints, Machine for washing, drying and ironing.....	265*
Boiler, B. & O., 2-10-2 type.....	456*
Boiler circulation, Ross-Schofield system for locomotives.....	645*
Boiler compound, Device for feeding.....	514*
Boiler construction, Locomotive.....	1453‡
Boiler course sheets, Tool for setting.....	152*
Boiler heads, Bracing of.....	454†
Boiler, Hot water washing system.....	371*
Boiler inspection, by Frank McManamy.....	13*
Boiler inspection, Locomotive.....	‡
Boiler lagging, Reclaiming, by Alden B. Lawson.....	41*
Boiler Makers' Association (see Master Boiler Makers' Association).	
Boiler patch bolts, Tools for applying, Sou. Pac.....	434*
Boiler, Pennsylvania Atlantic type locomotive.....	64*
Boiler plant, Locomotives as an emergency.....	94†
Boiler shop methods, American Locomotive Co.....	637*
Boiler tube cleaner, Lagonda.....	440*
Boiler tube sheet flanges, Rotary scarfing tool for.....	434*
Boiler tubes, Melted.....	397†, 452†
Boiler tubes, Melted, by M. A. Kinney.....	560†
Boiler tubes, Plant for repairing.....	311*
Boiler tubes, The welding of.....	13*
Boiler washing system, Gravity.....	545*
Boilers, locomotive, Strength of.....	111‡, 224†
Boilers, locomotive, Strength of, by William N. Allman.....	123*
Boilers, Patching according to law, by George J. Lynch.....	634*
Boilers, Reducing the weight of, by F. W. Dean.....	280†

### Books

Administration of Labor Laws and Factory Inspection in Europe.....	560
Air Brake Association Proceedings.....	503
Air Brake Catechism, by Robert H. Blackall.....	451
Alternating Currents and Alternating Current Machinery, by D. C. and J. P. Jackson.....	3
American Railway Master Mechanics' Association, Proceedings, 1913.....	60
Analyses of Coal in the United States, by N. W. Lord.....	60
Application of Power to Road Transports, by H. E. Wimperis.....	167
Applied Mechanics, by C. E. Fuller et al.....	224
Business Administration, by Edward D. Jones.....	341
Cambria Steel Handbook.....	395
Car Interchange Manual, Compiled by J. D. McAlpine.....	223, 559
Coal Mining Practice in District VIII (Danville), by S. O. Andros.....	223
Electric Car Maintenance, by Walter Jackson.....	167
Engineering Index Annual for 1913, The Engineering Manual.....	223, 395
Experiments with Furnaces for a Hand-Fired Tubular Boiler, by Samuel B. Flagg et al.....	559
Foremen and Accident Prevention.....	612
Fuels Used in Texas, The, by William B. Phillips et al.....	279
Good Engineering Literature, by Harwood Frost.....	224
Handbook for Machine Designers and Draftsmen, by Frederick A. Halsey.....	114
Handbook of United States Safety Appliance Standard for Freight Cars.....	279
How to Build Up Furnace Efficiency, by Joseph W. Hays.....	279
International Railway General Foremen's Association, Proceedings of 1914.....	559
Kansas Fuels; Coal, Oil and Gas.....	60
Link Motions, Valve Gears and Valve Settings, by Fred H. Colvin.....	395
Locomotive Ratios, by F. J. Cole.....	168
Machinery's Handbook.....	114
Master Boiler Makers' Proceedings.....	395
Master Car and Locomotive Painters' Proceedings, 1913.....	114

Page numbers under 1,000 refer to *Railway Age Gazette, Mechanical Edition*; those over 1,000 refer to the *Daily Railway Age Gazette*. \* Illustrated article; ‡ editorial; † short non-illustrated article or note; ‡ communication.



Books (Continued)

Master Car Builders' Association, Proceedings, 1913 60  
 Power and Power Transmission, by E. W. Kerr 560  
 Principles of Industrial Organization, by Dexter S. Kimball 114  
 Railway Fuel Association Proceedings, 1914 560  
 Railway Rolling Stock Appliances and Equipment 612  
 Scientific Management 60  
 Some Engineering Phases of Pittsburgh's Smoke Problem 395  
 Spontaneous Combustion of Coal, by S. W. Parr et al. 60  
 Structural Design, by Horace L. Thayer 279  
 Tests of Bond Between Concrete and Steel, by Duff A. Abrams 341  
 Tests of Metals at Watertown Arsenal 223  
 The Tractive Resistance of a 28-Ton Car, by Harold H. Dunn 341  
 The Science and Practice of Management, by A. Hamilton Church 612  
 Thermal Properties of Steam, by G. A. Goodenough 612  
 Traffic Glossary, by R. E. Riley 451  
 Work, Wages and Profit, by H. L. Gantt 167  
 Working Drawings of Machinery, by Walter H. James et al. 60  
 Boring bar head 90\*  
 Boring head, Three tool 89\*  
 Boring mill (see also Machine Tools).  
 Boring mill tool for turning outside surfaces Boston & Maine, Billerica repair shops, by F. K. Irwin 561\*  
 Boston & Maine, Saving time in the paint shop 93\*  
 Bosworth, W. M., Freight car design and construction 306\*  
 Bosworth, W. M., Reinforcing old wooden freight cars 246  
 Boutet, H., Interchange of cars 623  
 Bowser, S. F., & Co., Long distance gasoline and oil pumps 330\*  
 Brake beam safety hangers 1357\$  
 Brake beams, The hanging of 1285\$  
 Brake, The clasp, by F. M. Brinckerhoff 180  
 Brake cylinders, Arrangement on P. R. R. Mikado 347\*  
 Brake cylinder head gaskets, Clips for holding 380\*  
 Brake efficiency tests on steel and iron wheels, by F. K. Vial 187\*  
 Brake equipment, Locomotive 508\*  
 Brake gear, Foundation 302, 1285\$  
 Brake hangers, Dies for bending, P. R. R. 639\*  
 Brake head 1382\*  
 Brake head, Safety adjustable 1313\*  
 Brake performance on passenger trains, by S. W. Dudley, A. S. M. E. 136\*  
 Brake rigging, Clasp, Steel trucks with, New York Central 359\*  
 Brake shaft, Square, B. R. & P. 647\*  
 Brake shaft, Union drop 101\*  
 Brake shoe and brake beam equipment 1206\*  
 Brake shoe, Constant service wheel truing 269\*  
 Brake shoe efficiency, Determination of 1405\$  
 Brake shoe keys, A cheap method of making, by E. A. Murray 197\*  
 Brake and signal equipment 1294\*  
 Brake staffs, Punching holes in 248\*  
 Brake tests, Pennsylvania 113\$  
 Breese, S. E., Interior finish of passenger cars 529  
 Brick arch, Road tests of 1497  
 Brick, Heat insulating 1504‡  
 Bridgeford Machine Tool Works, Gap axle lathe 203\*  
 Brinckerhoff, F. M., The clasp brake 180  
 Brown, F. R., Efficiency from store department employees 297  
 Brown, H. M., Turning driving wheel tires 61\*  
 Brown, L., Gages for flexible staybolts 253\*  
 Brushes, Buying on specifications, by H. M. Baxter 128  
 Buffalo Brake Beam Co., Safety adjustable brake head 1313\*  
 Buffalo, Rochester & Pittsburgh, Square brake shaft 647\*  
 Buffers, Abolishing dead, in England 144‡  
 Buffing gear, Friction 328\*  
 Bulleid, O. V. P., Maximum permissible error in crank pin location 348\*  
 Bundy, C. L., Best type of draft gear for freight cars 404  
 Bundy, C. L., Freight car repairs 179  
 Business conditions, The most trying time is past 1286\$  
 Business, The outlook for better 1259\$

C

Cab curtains, Economizing in 165\$  
 Cah, Vestibule, Canadian Pacific 169\*  
 Calvert, R. F., Device for removing stand pipes 488\*  
 Calvert, R. F., Punching holes in brake staffs 248\*  
 Calvert, R. F., Tool clamp for wheel lathes 644\*  
 Calvert, R. F., Turring crank pins 475\*  
 Canadian Locomotive Co., Ltd., Structural steel tender truck 542\*

Canadian Pacific

All-steel trucks for passenger service 26\*  
 Blue flag holder 629\*  
 Cast iron wheel records 82\*  
 Chemical treating of feed water 316  
 Electric welding at Angus shops 321\*  
 Gages for flexible staybolts 253\*  
 Inspection and work schedules at Angus shops 193\*  
 Interior finish of passenger cars 528  
 Piece work system at Angus shops 249\*  
 Reinforcing box cars on 86\*  
 Shop for steel car construction 242\*  
 Short rivet shear 642\*  
 Some notes on chilled cast iron wheels 470\*  
 Special dining car for troops 522\*  
 Steel coach 237\*  
 Steel freight car repair shops 131\*  
 Steel steps for passenger cars 370\*  
 2-8-2 type locomotive 169\*

Canadian Railway Club (see also Meetings).  
 Canton Foundry Machine Co., Portable crane and hoist 601\*

Car

Armored box, for transporting troops in Mexico 464\*  
 Axles, Reclaiming, on the Erie 644\*  
 Baggage, Steel door for 1403  
 Bearing, Frictionless return roller, A. C. L. 384\*  
 Box, Defective 360  
 Box, door, Edman 1403\*  
 Box, End construction in 610\$  
 Box, Grain tight construction for single sheathed, by W. J. Tollerton 81\*  
 Box, Overhead inspection of 1369\*  
 Box, Reinforcing, Can. Pac. 86\*  
 Box, The greatest weakness in, by R. P. Blake 630  
 Box, The standard 1383\$  
 Box, Steel ends for, by W. A. McGee 190\*  
 Box, Stresses in members of steel, by W. F. Kiesel, Jr. 23  
 Brake shaft, Square, B. R. & P. 647\*  
 British steel 502\$  
 Construction 1390\*  
 Construction, Refrigerator 152‡  
 Convertible box and stock, St. L. & S. F. Closet, Dayton Manufacturing Co. 386\*  
 Construction, M. C. B. report 1390\*  
 Coupler, Experimental standard 1358\$  
 Coupler, Intermediate 1403  
 Coupler with centering lug, L. J. 521\*  
 Dairy refrigerator 308\*  
 Department competition 609\$  
 111\$, 395\$, 450\$, 501\$, 609\$  
 Department correspondence 521  
 Department, Give the, a square deal 1384  
 Department organization and efficiency 235  
 Designers, Questions for 225\*  
 Designers, Questions for, by C. H. Faris 396‡  
 Dining for the Burlington 77\*  
 Dining, Special, for troops, Can. Pac. 522\*  
 Discussion of steel box 23  
 Door, Corrugated steel, with fender attachment 547\*  
 Door, End arrangement on Nor. Pac. stock 181\*  
 Doors, Painting steel, Master Painters' convention 643\*  
 Door, Steel freight, P. R. R. 421\*  
 Draft gear, Friction 468  
 Draft gear, Maintenance of 278\$  
 Draft gear problem, The 467\*  
 Draft gear problem and its solution 399\*  
 Draft gear, The essentials of a good 465\*  
 Draft gear, Yost 332\*  
 End sill, C. B. & O. 79\*  
 Freight, Christy steel roof 261\*  
 Freight, construction 1383\$  
 Freight, Design and construction 306\*  
 Freight, Form for noting repairs 526\*  
 Freight, Orders for 1357\$  
 Freight, Standard lettering for, Painters' convention 530  
 Freight, Uniform stenciling of, by J. H. Pitard 612‡  
 Foreign, question, by D. J. Durrell 130  
 Foreign, Steel construction in 523  
 Heater 184  
 Heating control, Electric thermostatic 267\*  
 High capacity well, Lehigh Valley 75\*  
 Hopper, Safety wrench for 270\*  
 Inspection, Uniform, for special loading 463\*  
 Interchange, by H. Boutet 623  
 Iron box, on the B. & O., by O. C. Cromwell 23  
 Journal box, Air ventilated 103\*  
 Journal boxes, Hot 299  
 Journal cooler 155\*  
 Journals, Packing and lubricating 369  
 Lighting 184  
 Lighting batteries, Ampere-hour control for charging 1312\*  
 Lighting, Generator suspension 1382\*  
 Lighting, Semi-indirect fixture 1312\*  
 Local conditions affect design, by E. G. Chenoweth 24  
 Low capacity, The retirement of 1384\$  
 Lunch counter, P. R. R. 22\*

Car (Continued)

Lunch counter, Rock Island 582\*  
 Milk refrigerator, B. & O. 621\*  
 Mine rescue, for Ohio 190‡  
 On curves 357\*  
 Passenger, Baggage rack, Santa Fe 646\*  
 Passenger, Ceiling fan for 1403  
 Passenger, Cost of replacing wooden, with steel 1266  
 Passenger, Decorations on 1285\$  
 Passenger, Interior finish of, Painters' convention 538  
 Passenger repairs, Classification of 529\*  
 Passenger, Speedometer and recorder for 1275\*  
 Passenger, Steel trucks for 26\*  
 Passenger, step 1382\*  
 Refrigerator, Dairy, Milwaukee Refrigerator Transit & Car Co. 367\*  
 Refrigerator design 58\$, 135  
 Refrigerator door fixtures 49\*  
 Refrigerator, Tests of 241  
 Reinforcing wooden box 57\$  
 Repair notes 198\*  
 Repair shops, Steel freight, by E. T. Spidy 131\*  
 Repair track mileage does not pay dividends 466  
 Repairs, Freight, by C. L. Bundy 179  
 Repairs, The surcharge in 1286\$  
 Retirement of 40,000 and 50,000 lb. capacity 1394  
 Roller bearings on 2\$, 19\*  
 Roof, C. B. & O. 79\*  
 Roof, Can. Pac. 237\*  
 Roof, Pennsylvania steel box car 423\*  
 Roofs, Testing for leakage 374\*  
 Self-propelled 144‡  
 Shops, Adjustable platform for 200\*  
 Side bearing, roller, Creco 1276\*  
 Standard, improbable, by H. H. Vaughan 25  
 Steel baggage, L. I. 517\*  
 Steel box, P. R. R. 419\*  
 Steel caboose for the Pennsylvania 577\*  
 Steel coach and combination, Jersey Central 625\*  
 Steel, Interstate Commerce Commission and 28  
 Steel, Painting, by Milton L. Sims 641  
 Steel, Painting, Painters' convention 527  
 Steel passenger, Can. Pac. 185\*  
 Steel passenger, Can. Pac. 237\*  
 Steel, Sand blast for cleaning, by J. M. Betton 17\*  
 Steel, Shop for the construction of, Can. Pac. 242\*  
 Step with four treads, G. T. 523\*  
 Steps, Steel, Can. Pac. 370\*  
 Stock, Nor. Pac. 181\*  
 Track exhibit 1411\*  
 Truck, Arch bar with swing bolster 521\*  
 Truck, M. C. B. 1370\*  
 Truck report 1357\$  
 Truck, Six-wheel, for Lehigh Valley well car 75\*  
 Truck, Steel, with clasp brake rigging, New York Central 359\*  
 Trucks, M. C. B. report 1370\*  
 Underframe, C. B. & O. 78\*  
 Underframe, Steel, N. Y. N. H. & H. 185\*  
 Underframe, Steel, for Nor. Pac. stock 181\*  
 Ventilator, all-steel, by C. A. Seley 24  
 Ventilator, Mudge-Peerless 548\*  
 Ventilator, Utility honeycomb 1403\*  
 Vestibule, Can. Pac. 237\*  
 Vestibule connections, European 573\*  
 Wheel design, Cast iron 189  
 Wheel drop pit, Intercolonial Railway of Canada 100\*  
 Wheel shop, M. St. P. & S. S. M. 33\*  
 Wheels 1286\$  
 Wheels, Master Mechanics' convention 1298\*  
 Wheels, Some notes on chilled cast iron 470\*  
 Windows, Reflector for 310\*  
 Wooden freight, Reinforcing old 246  
 Wooden freight, Steel underframes for use on 515\*  
 Wooden, in freight trains, by G. E. Smart 581  
 Wooden, in freight trains, discussion at Canadian Railway Club 631  
 Wooden underframe, What should be done with 235  
 Work, Articles on 1\$  
 Car days, Saving, Sou. Pac. 516  
 Car Foremen's Association of Chicago (see also Meetings) 1384\$  
 Car spotting decision 481\*  
 Carbon and high speed steel 235  
 Carey, A., Car department organization and efficiency 270  
 Carling, Asbestos, Franklin 485  
 Casehardening with gas, American Gas Furnace Co. 492\*  
 Catalogs, 56, 110, 164, 219, 276, 338, 392, 448, 500, 556, 608, 656.  
 Cayuta Manufacturing Co., Motor driven screw jack 1476\*  
 Central of Georgia, Chuck for eccentrics 379\*  
 Central of Georgia, Pneumatic press for general work 385\*  
 Central of Georgia, Tool room notes 638\*

Page numbers under 1,000 refer to *Railway Age Gazette, Mechanical Edition*; those over 1,000 refer to the *Daily Railway Age Gazette*. \* Illustrated article; † editorial; ‡ short non-illustrated article or note; § communication.



Central Railroad of New Jersey, Steel passenger cars .....	625*	Competition, Car department.395\$, 450\$, 501\$, 609\$	Draft Gear (Continued)
Charlton, G. J., Packing and lubricating journals .....	369	Competition, Car department, prize winner... 111\$	Gould friction, for steel bumper beams. 328*
Chart on logarithmic co-ordinate paper.....	120*	Competition, Draft gear, prize winner... 339\$	Maintenance of .....
Chart, speed, Lehigh Valley.....	119*	Competition, The draft gear.111\$, 166\$, 221\$, 277\$	More information wanted about the.... 340\$
Chenoweth, E. G., Local conditions affect car design .....	24	Competition, Engine house, prize winner... 393\$	Performance, by E. S. Pearce..... 401*
Chesapeake & Ohio, Boring eccentric straps 342*‡		Competition on engine house work. 222\$, 277\$, 340\$	Prize for data on best type of..... 111\$
Chesapeake & Ohio, Hot water boiler washing system .....	371*	Consolidated Railway Electric Light & Equipment Co., Ampere-hour control for charging car lighting batteries..... 1312*	Problem, A solution of the, by J. W. Hogsett .....
Chesapeake & Ohio, Making brake shoe keys 197*		Convention reports, Mechanical department. 393\$	Problem, Importance of the, by H. H. Hauser .....
Chesapeake & Ohio, Spring rigging and tire repairs .....	374*	Convention, Tool Foremen's..... 394\$	Problem, Papers submitted in the draft gear competition .....
Chesapeake & Ohio, Turning driving wheel tires .....	614, 281*‡	Convention, Traveling Engineers' .....	361, 399,
Chesapeake & Ohio, 4-6-2 type locomotive... 614*		Convention hall, A better, needed..... 1427\$	Problem, Repair track mileage does not pay dividends, by F. H. Sweringen... 466
Chicago & Alton, Special tools.....	435*	Conventions, July mechanical..... 339\$	Problem, The....340\$, 395\$, 449\$, 504\$, 612‡
Chicago & North Western, Chemical treating of feed water.....	316	Conventions, May and June..... 221\$	Problem, The, by E. W. Newell..... 361
Chicago & North Western, Clips for holding brake cylinder head gaskets.....	380*	Copyright, Notice of..... 1259\$	Problem, The so-called, by Myron E. Wells .....
Chicago & North Western, Dial rims for adjusting gage hands.....	92*	Cornell Alumni dinner at Atlantic City.... 334	Problem, Why attempt the impossible? by Millard F. Cox..... 400
Chicago & North Western, Grinding in rotary valves on E-T equipment.....	42	Correspondence, Car department..... 521	Spring versus friction..... 453‡
Chicago & North Western, Portable combination test rack .....	378*	Countersinking machine (see also Machine Tools).	The best type of, for freight cars, by C. L. Bundy..... 404
Chicago & North Western, Roundhouse test rack for examining lubricators.....	152*	Coupler, Experimental standard..... 1358\$	The essentials of a good, by H. C. May. Yost .....
Chicago, Burlington & Quincy, Dining cars. Chicago Injector Co., Four-speed flange roller Chicago, Milwaukee & St. Paul, Welding practice on .....	77* 600*	Coupler, The standard..... 1357\$	
Chicago Pneumatic Tool Co., Air compressor Chicago Pneumatic Tool Co., Clock attachment for Boyer speed recorder.....	586* 1478*	Coupler with centering lug, L. I..... 521*	Drafting dictionary needed..... 616‡
Chicago Pneumatic Tool Co., Countersinking machine .....	104*	Couplers, M. C. B. experimental standard... 1361*	Drawing office, General officers and the... 279\$
Chicago Pneumatic Tool Co., Cross compound air compressor.....	208*	Couplings, Flange and screw for injectors. 1439*	Drawing office, Improving..... 1427\$
Chicago Pneumatic Tool Co., Low grade fuel oil engine .....	1452*	Coutant, J. G., A home-made powdered coal plant .....	Drill (see also Machine Tools).
Chicago Railway Equipment Co., Brake head Chicago Railway Equipment Co., Roller side bearing .....	1382* 1276*	Coutant, J. G., Powdered fuel for railway shops .....	Drilling, Air motor for light..... 434*
Chief Interchange Car Inspectors' and Car Foremen's Association (see also Meetings).		Cox, Millard F., Why attempt the impossible? .....	Driving box oil groove cutting device..... 435*
Chiles, George S., Starting power of a locomotive .....	5*	Crandall, Bruce V., The draft gear problem Crane, Ball bearing column.....	Driving boxes, Reclaiming cast steel, A. C. L..... 375*
Christopher Murphy Co., Staybolt chuck... 547*		Crane, Portable floor and hoist with back gear .....	Driving wheel tires, Depth of cut for turning Driving wheel tires, Turning..... 61‡
Chuck for holding holts in lathe.....	89*	Crank pin location, Maximum permissible error in .....	Drop forging, report at Master Blacksmiths' convention .....
Chuck for holding small work in lathe.....	90*	Crist, W. E., Air ventilated journal box... 103*	Drop pit, Car wheel..... 100*
Cincinnati Electrical Tool Co., Electric hand drill .....	327*	Crownwell, O. C., Iron box cars on the B. & O..... 23	Dudley, E. L., Encourage employees to study 342‡
Cincinnati Planer Co., Cylinder planer.....	210*	Crop movement, Prepare cars for..... 1259\$	Dudley, E. L., Why college men leave railway work .....
Cincinnati Planer Co., Reversible motor driven planer .....	1504*	Crosshead shoes, Jig for drilling, B. & O. 320*	Dudley, S. W., Brake performance on passenger trains .....
Cincinnati Planer Co., 84-inch planer.....	102*	Crosshead, Valve stem for Lehigh Valley 4-6-2 type .....	Duffey, Paul R., Chuck for turning eccentrics .....
Circle, Dividing the circumference of a, by W. H. Wolfgang.....	620	Crown sheet expansion stays..... 375*	Duffey, Paul R., Depth of cut for turning driving wheel tires..... 322
Classification of repairs for paint shop.....	529	Curtain fixtures .....	Duffey, Paul R., Emery wheel stand..... 380*
Cleaning of locomotives, Efficient.....	609\$	Curtain Supply Co., Vestibule curtain fixtures .....	Duffey, Paul R., Pipe bending machine..... 476*
Cleary, Frank, Car department correspondence .....	521	Curtis Pneumatic Machinery Co., Pneumatic press for general work..... 385*	Duffey, Paul R., Removing front tube sheets 39*
Clinker and honeycomb formation, Report at Fuel Association convention.....	283	Curves of locomotive performance, by Prof. A. J. Wood..... 458*	Duffey, Paul R., Tool for setting boiler course sheets .....
Closet, Car, Dayton Manufacturing Co. Coaches (see Car).....	386*	Curves, Rolling stock on..... 357*	Duffey, Paul R., Tool room equipment and management .....
Coal briquettes .....	332‡	Cylinder cocks, Tools for finishing, N. & W. 432*	Durham, W. E., Notes on present day running repairs .....
Coal crusher at Lima Locomotive Corporation .....	96*	Cylinders, Arrangement of, on P. R. R. Mikado .....	Dunning, F. W., Device for feeding boiler compound .....
Coal, Honeycomb and clinker formation.... 283		Cylinders, Drilling the smokebox flanges of 319*	Durell, D. J., Foreign car question..... 130
Coal in Russia.....	258‡	Cylinders, Larger locomotive..... 50‡	Dust guard, Journal box..... 646*
Coal passer for tenders.....	442*	Cylinders, valves, crossheads and guides, Report at General Foremen's convention. 411	
Coal pile, Pops and the.....	222\$	C & C Electric & Manufacturing Co., Portable arc welder..... 541*	
Coal, Pittsburgh, Tests of the weathering of Coal, powdered, A home-made plant for preparing, by J. G. Coutant.....	572		
Coal, powdered, A home-made plant for preparing, by J. G. Coutant.....	254*		
Coal pulverizer at Lima Locomotive Corporation .....	96*		
Coal, Sizing, for locomotive use, Fuel Association report .....	289		
Coal space and adjuncts of tenders, Fuel Association report .....	290		
Coal sprinkler, Hancock.....	325*		
Coal, Storage of, Fuel Association report... 287			
Coaling facilities at terminals, Provide adequate .....	502\$		
Coaling station, Modern locomotive, Fuel Association report .....	349		
Coaling station, Reinforced concrete.....	122*		
Coates, C. G., Reclaiming scrap material.... 452‡			
Coddington, H. W., Road tests of Schmidt superheater and brick arch .....	1497		
Collar, Adjustable spacing for milling cutter College man and the railroads, The.... 168‡, 394\$			
College men and the railroads.....	31, 115‡		
College men and the railroads, by C. H. Benjamin .....	62‡		
College men in railroad work.....	396‡		
College men in railroad work, by M. K. Barnum .....	73		
College men, Why, leave railway work, by E. L. Dudley.....	280‡		
Colleges and our mechanical associations... 1406\$			
Collett, Robert, Address at Fuel Association convention .....	283		
Combustion chambers in large locomotives, Report at Master Boiler Makers' convention .....	317		
Combustion, Practical chemistry of.....	511		
Committee reports, illustrations.....	1479\$		
Competition, Car department.395\$, 450\$, 501\$, 609\$			
Competition, Car department, prize winner... 111\$			
Competition, Draft gear, prize winner... 339\$			
Competition, The draft gear.111\$, 166\$, 221\$, 277\$			
Competition, Engine house, prize winner... 393\$			
Competition on engine house work. 222\$, 277\$, 340\$			
Consolidated Railway Electric Light & Equipment Co., Ampere-hour control for charging car lighting batteries..... 1312*			
Convention reports, Mechanical department. 393\$			
Convention, Tool Foremen's..... 394\$			
Convention, Traveling Engineers' .....	503\$		
Convention hall, A better, needed..... 1427\$			
Conventions, July mechanical..... 339\$			
Conventions, May and June..... 221\$			
Copyright, Notice of..... 1259\$			
Cornell Alumni dinner at Atlantic City.... 334			
Correspondence, Car department..... 521			
Countersinking machine (see also Machine Tools).			
Coupler, Experimental standard..... 1358\$			
Coupler, The standard..... 1357\$			
Coupler with centering lug, L. I..... 521*			
Couplers, M. C. B. experimental standard... 1361*			
Couplings, Flange and screw for injectors. 1439*			
Coutant, J. G., A home-made powdered coal plant .....	254*		
Coutant, J. G., Powdered fuel for railway shops .....	95*		
Cox, Millard F., Why attempt the impossible? .....	400		
Crandall, Bruce V., The draft gear problem Crane, Ball bearing column.....	612‡ 436*		
Crane, Portable floor and hoist with back gear .....	601*		
Crank pin location, Maximum permissible error in .....	348*		
Crist, W. E., Air ventilated journal box... 103*			
Crownwell, O. C., Iron box cars on the B. & O..... 23			
Crop movement, Prepare cars for..... 1259\$			
Crosshead shoes, Jig for drilling, B. & O. 320*			
Crosshead, Valve stem for Lehigh Valley 4-6-2 type .....	119*		
Crown sheet expansion stays..... 375*			
Curtain fixtures .....	1313		
Curtain Supply Co., Vestibule curtain fixtures .....	1314*		
Curtis Pneumatic Machinery Co., Pneumatic press for general work..... 385*			
Curves of locomotive performance, by Prof. A. J. Wood..... 458*			
Curves, Rolling stock on..... 357*			
Cylinder cocks, Tools for finishing, N. & W. 432*			
Cylinders, Arrangement of, on P. R. R. Mikado .....	346*		
Cylinders, Drilling the smokebox flanges of 319*			
Cylinders, Larger locomotive..... 50‡			
Cylinders, valves, crossheads and guides, Report at General Foremen's convention. 411			
C & C Electric & Manufacturing Co., Portable arc welder..... 541*			

D

E



Engine failures on the Cotton Belt, by Raffe Emerson ..... 292  
 Engine failures, The road foreman's part in preventing ..... 502§  
 Engine house competition ..... 340§  
 Engine house competition prize winner ..... 393§  
 Engine house efficiency, by W. W. Smith ..... 407  
 Engine house forces, Organization of ..... 477\*  
 Engine house, modern, Efficiency in a, by John C. Murdock ..... 642  
 Engine house work, Competition on ..... 222§, 277§  
 Engine house work, Resourcefulness needed in ..... 394§  
 Engine house work, Training men for, by Charles Maier ..... 127  
 Engine houses, Firing up engines at ..... 636  
 Engine houses, Repair work at small, by G. H. Roberts ..... 633  
 Engine houses, Inspection at ..... 449§  
 Equipment and operation, Regulation of ..... 1260§  
 Equipment, Steel passenger train ..... 1266  
 Erecting shop, methods in ..... 61‡  
 Erie Railroad, Apprentice school ..... 31\*  
 Erie Railroad, Fuel oil burner ..... 253\*  
 Erie Railroad, General machine tool efficiency ..... 255\*  
 Erie Railroad, Jig for machining eccentrics ..... 94\*  
 Erie Railroad, Portable tire heater ..... 94\*  
 Erie Railroad, Reclaiming car axles ..... 644\*  
 Erie Railroad, 2-8-8-8-2 type locomotive ..... 221§, 227\*  
 Esterline Co., Graphic service recorder ..... 598\*  
 Everett, F. D., Electric locomotive data ..... 415  
 Exhaust nozzle, Grinding, A. C. L. .... 322\*  
 Exhaust nozzles, Size of ..... 142‡  
 Exhibit better than ever ..... 1259§  
 Exhibit, The track ..... 1406§  
 Exhibit, track, Locomotives and cars in the ..... 1411\*

**F**

Fan, Ceiling for passenger cars ..... 1403  
 Farris, C. H., Questions for car designers ..... 396  
 Farr, Arthur V., Ball bearings on turntables ..... 329\*  
 Faucet, mail car, Chadwick ..... 599\*  
 Feed valve test rack ..... 202\*  
 Feed water, Chemical treating of ..... 316  
 Feed water, Pre-heating locomotive boiler, report at Fuel convention ..... 290\*  
 Firebox riveting, by N. H. Ahnsuolb ..... 191\*  
 Fireboxes, Autogenous welding in, by N. H. Ahnsuolb ..... 149\*  
 Fire door, Gravity ..... 550\*  
 Fire door, Locomotive, Ann Arbor R. R. .... 104\*  
 Fire extinguisher, Northern Fire Apparatus Co. .... 212\*  
 Fire quencher, Safety for blacksmith shop ..... 601\*  
 Firing practice, report at Fuel convention ..... 290  
 Firing up engines at engine houses ..... 636  
 Flag holder for blue flag, Can. Pac. .... 629\*  
 Flanagan, M., Boring eccentric straps ..... 342‡  
 Flanagan, M., Turning driving wheel tires ..... 281‡  
 Flange lubricators, Automatic, Detroit Lubricator Co. .... 383\*  
 Flue cleaning, Effect of the method on scaling, Boiler Makers' convention ..... 318  
 Flue hole cutter ..... 435\*  
 Foltz, F. W., Economies in fuel consumption ..... 355  
 Foote-Burt Co., Mud ring and flue sheet drill ..... 208\*  
 Foreign subscribers, June dailies for ..... 221§  
 Foremen, The training of ..... 558§  
 Forging, Drop ..... 483\*  
 Forging machine dies, Master Blacksmiths' convention ..... 639\*  
 Form for noting car repairs ..... 526\*  
 Fossdick Machine Tool Co., Radial drills ..... 158\*, 331\*  
 Foster, O. M., Flange and screw couplings for injectors ..... 1439\*  
 Foundry, Eating in the ..... 473‡  
 Four cylinder locomotives ..... 1§  
 Frame making and repairing ..... 484\*  
 Franklin Manufacturing Co., Asbestos car lining ..... 270  
 Freight, Precooling perishable ..... 150‡  
 Freight trains, Wooden cars in, by G. E. Smart ..... 581  
 Freight trains, Wooden cars in, discussion at Canadian Railway Club ..... 631  
 Front end arrangement on P. R. R. Mikado and Pacific types ..... 346\*  
 Front end design ..... 284\*  
 Front ends, Locomotive, 1853-1913 ..... 617\*  
 Fuel Association (see Railway Fuel Association).  
 Fuel Association, The ..... 278§  
 Fuel consumption, Economies in, report at Fuel convention ..... 355  
 Fuel consumption, Uniform methods of computing, report at Fuel convention ..... 286\*  
 Fuel economy, Consideration of, continued ..... 1479§  
 Fuel economy, Locomotive ..... 222§  
 Fuel economy, M. M. convention ..... 1494\*  
 Fuel oil, Abandoning ..... 282‡  
 Fuel, Powdered ..... 462  
 Fuel, Powdered, for railway shops, by J. G. Coutant ..... 95\*

**G**

Gage, Depth for telltale holes ..... 434\*  
 Gages for fitting air valves, by J. A. Jesson ..... 258\*  
 Gale, W. T., Repair notes ..... 198\*

Gamble, H. E., Address at Master Blacksmiths' convention ..... 481  
 Gas, Natural, in the United States ..... 104‡  
 Gas producer at Juanita shops, P. R. R. .... 437\*  
 Gearhart, J. F., Classification of coach repairs ..... 529  
 Gerber, J. W., Address at Storekeepers' Association convention ..... 294  
 Gilbride, R. G., Organization of engine house forces ..... 477\*  
 Gisholt Machine Co., Driving box boring mill ..... 439\*  
 Given, A. R., Interior finish of passenger cars ..... 528  
 Glass cutter, Circular, L. S. & M. S. .... 638\*  
 Grand Trunk, Coach step with four treads ..... 523\*  
 Graphite Lubricator Co., Graphite lubricator ..... 602\*  
 Grates, Air openings of ..... 284\*  
 Grease plug, Locked ..... 50\*  
 Griffin Wheel Co., Brake efficiency tests on steel and iron wheels ..... 187\*  
 Grinder, Soft metal for superheater unit connections ..... 549\*  
 Grinding machine (see also Machine Tools).  
 Grinding, Tool room ..... 427  
 Grinding wheels and their use, by A. R. Davis ..... 201  
 Grinding wheels, by C. J. Morrison ..... 40  
 Grinding wheels, Protection of ..... 88  
 Grinding wheels, Safety applied to ..... 428\*  
 Goggles in railway shops ..... 488\*  
 Gold Car Heating & Lighting Co., Positive locking hose conpler ..... 600\*  
 Gold Car Heating & Lighting Co., Thermostatic heat control ..... 267\*  
 Goodwin, W. E., Special tools ..... 435\*  
 Goss, Dr. W. F. M., Address at Fuel Association convention ..... 283  
 Gould Coupler Co., Cast steel bumper ..... 328\*  
 Gould Coupler Co., Intermediate coupler ..... 1403  
 Gould Coupler Co., Journal box with pinless lid ..... 1382  
 Gould Coupler Co., Pedestal jaw truck frame ..... 1314‡  
 Guide bars, Lubricating bottom ..... 91\*

**H**

Hall, C. G., Storage of coal ..... 287  
 Hammers, Motor drive for, Beaudry ..... 44\*  
 Hancock Inspirator Co., Coal sprinkler ..... 325\*  
 Hanna Locomotive Stoker Co., Improved Hanna stoker ..... 205\*  
 Harrington, Edwin, Son & Co., Inc., Four spindle radial drilling machine ..... 99\*  
 Harrison, Fairfax, Address at Storekeepers' Association convention ..... 294  
 Hart-Otis Car Co., Ltd., Yost draft gear ..... 332\*  
 Harvey, George L., Friction draft gear ..... 468  
 Hatch, M. C. M., Front end design ..... 284\*  
 Hatch, W. J., Address at Air Brake convention ..... 301  
 Hauser, W. H., Importance of the draft gear problem ..... 364  
 Headlight discussion, A thorough ..... 1453§  
 Headlight equipment, Electric ..... 1477\*  
 Headlight equipment, electric, Installation and maintenance of ..... 36\*, 145\*  
 Headlights, electric, Wiring for ..... 115‡  
 Headlights, Government regulation of ..... 1454§  
 Headlights, Locomotive, M. M. convention ..... 1457\*  
 Headlights, Wiring for electric ..... 281‡  
 Heat treatment of metals ..... 485  
 Hess-Steel Castings Co., Wrench for hopper car ..... 270\*  
 Hofius Steel & Equipment Co., Roller friction clutch for throttle and reverse levers ..... 101\*  
 Hogsett, J. W., A solution of the draft gear problem ..... 399  
 Hoist, Largest electric, in America ..... 91‡  
 Hoist, Portable electric, Northern ..... 267\*  
 Hoist, Portable steam or air, Ingersoll-Rand ..... 490\*  
 Hoist, Two-motor monorail, Shaw ..... 491\*  
 Honeycomb and clinker formation, report at Fuel convention ..... 283  
 Hose, Air brake (see Air Brake Hose).  
 Hose coupler, steam, Positive locking ..... 600\*  
 Hours of service act ..... 342‡  
 Hydraulic bushing press, R. D. Wood & Co. .... 494\*  
 Hydraulic Press Manufacturing Co., Pilot operated valve for hydraulic presses ..... 440\*  
 Hydraulic Press Manufacturing Co., Triplex hydraulic pump ..... 323\*  
 Hydraulic press, Pilot operated valve for ..... 440\*

**I**

Illinois Central, Burning out oil deposits in air pumps ..... 538\*  
 Illinois Central, Milling machine efficiency ..... 593\*  
 Illinois Central, Repairing a cut journal ..... 640\*  
 Illumination of shops by quartz lamps ..... 650\*  
 Illustrations, Committee reports ..... 1479§  
 Improvements in locomotives ..... 2§  
 Independent Pneumatic Tool Co., Portable electric drill ..... 441\*  
 India, Rope railway in ..... 328‡  
 Indiana Harbor Belt Railway, Coaling station ..... 122\*  
 Industrial Welfare and Efficiency Conference ..... 553  
 Ingersoll-Rand Co., Direct oil driven air compressor ..... 383\*  
 Ingersoll-Rand Co., Pneumatic rivet set retainer ..... 441\*

Ingersoll-Rand Co., Portable steam or air hoist ..... 490\*  
 Ingersoll-Rand Co., Rivet buster ..... 648\*  
 Ingersoll-Rand Co., Roller bearing pneumatic drills ..... 102\*  
 Injector connections, Jig for reducing and expanding ..... 198\*  
 Injector coupling nut, Wm. Sellers & Co. .... 264\*  
 Injector, Strainer and drain valve ..... 326\*  
 Injectors, Flange and screw couplings for ..... 1439\*  
 Inspection, Overhead, of box cars, M. C. B. .... 1358§, 1369\*  
 Inspection, Uniform, for special loading ..... 463\*  
 Interchange Inspectors' convention ..... 339§, 473  
 Interchange of cars, by H. Boutet ..... 623  
 Interchange, Revision of the rules of, ..... 1300\*  
 Intercolonial Railway, Adjustable platform for car shops ..... 200\*  
 Intercolonial Railway of Canada, Car wheel drop pit ..... 100\*  
 International Association for Testing Materials, Seventh Congress of the (see also Meetings).  
 International Engineering Congress ..... 214, 653  
 International Oxygen Co., Oxygen testing apparatus ..... 649\*  
 International Railway Fuel Association (see Railway Fuel Association).  
 International Railway General Foremen's Association ..... 653  
 International Railway General Foremen's Association (see General Foremen's Association).  
 International Railroad Master Blacksmiths' Association (see Master Blacksmiths' Association).  
 Interstate Commerce Commission, Accident bulletin No. 48 ..... 166§  
 Interstate Commerce Commission and steel cars ..... 28  
 Interstate Commerce Commission, Locomotive boiler inspection ..... 13\*  
 Investment, Big returns for a small ..... 1453§  
 Ireland, Fast run in ..... 282‡  
 Iron box cars on the B. & O. .... 23  
 Irwin, F. K., Boston & Maine repair shops ..... 561\*

**J**

Jack, Emergency ..... 647\*  
 Jack, Motor driven screw ..... 1476\*  
 Jenkins Brothers, Roundhouse blower valve ..... 438\*  
 Jesson, J. A., Air valve gages ..... 258\*  
 Jesson, J. A., Feed valve test rack ..... 202\*  
 Jesson, J. A., Jig for grinding in rotary valves on E-T equipment ..... 115‡  
 Jesson, J. A., Repairing air pump governors ..... 373\*  
 Jesson, J. A., Repairing slide valve feed valves ..... 141\*  
 Jig for boring side rods ..... 91  
 Jig for grinding in rotary valves on E-T equipment ..... 115‡  
 Job, Robert, Study of an internal transverse fissure in a failed axle ..... 405\*  
 Johns-Manville Co., H. W., Automatic car seal ..... 1313\*  
 Johns-Manville Co., H. W., Speedometer and recorder for passenger cars ..... 1275\*  
 Johnson, Harold S., Watering the rails to prevent slipping ..... 282‡  
 Johnson, W. E., Wiring for electric headlights ..... 115‡, 281‡  
 Journal bearings, Bronze metal for ..... 324  
 Journal box, Air ventilated ..... 103\*  
 Journal box packing ..... 609§  
 Journal box dust guard ..... 646\*  
 Journal box packing, Reclaiming, by Alden B. Lawson ..... 129\*  
 Journal box, Roller bearings on the Bangor & Aroostook ..... 19\*  
 Journal box with pinless lid ..... 1382  
 Journal boxes, Hot ..... 299  
 Journal cooler, Transportation Utilities Co. .... 155\*  
 Journals, Packing and lubricating ..... 369  
 Journal, Repairing a cut, Ill. Cent. .... 640\*

**K**

Kelley Railway Appliance Co., Car replacer ..... 1452‡  
 Kelly, Wm. J., Form for noting freight car repairs ..... 526\*  
 Kerr, A. B., Apprentice material ..... 319  
 Kerr, A. B., The apprentice—a boy ..... 150  
 Kiesel, W. F., Jr., Stresses in the members of steel box cars ..... 23  
 Kimball, Dexter S., College men and the railroads ..... 12  
 Kinney, M. A., Melted boiler tubes ..... 560‡  
 Kinsey, Owen D., Milling machine efficiency ..... 593\*  
 Kinyon, Alonzo G., Practical chemistry of combustion ..... 511  
 Kinyon, Alonzo G., Sizing of coal for locomotive use ..... 289  
 Kirby, Fred, Speed recorders ..... 511  
 Kopp, Charles E., Saving time in the paint shop ..... 93\*  
 Kropidowski, V. T., Installation and maintenance of electric headlight equipment ..... 36\*, 145\*  
 Kropidowski, V. T., Wiring for electric headlights ..... 281‡  
 Kreutzberg Meter Co., High pressure volumetric air meter ..... 331\*  
 Kuhn, B. F., Electric motors in railway shops ..... 1442

Page numbers under 1,000 refer to *Railway Age Gazette*, Mechanical Edition; those over 1,000 refer to the *Daily Railway Age Gazette*. \* Illustrated article; § editorial; ‡ short non-illustrated article or note; † communication.



## L

Lagging, boiler, Reclaiming, by Alden B. Lawson	41*
Lagging pulverizing machine	97*
Lagoda Manufacturing Co., Turbine boiler tube cleaner	440*
Lake Shore & Michigan Southern, Circular glass cutter	638*
Lake Shore & Michigan Southern, Interior finish of passenger cars	529
Lake Shore & Michigan Southern, Safety appliance standards	576
Lake Shore & Michigan Southern, Steel ends for box cars	190*
Landon, William G., Step for locomotive running boards	281*
Lanier, Monro B., Pre-heating locomotive boiler feed water	290*
Lathe, vertical turret, Machining pistons on a, A. C. L.	92*
Lathe (see also Machine Tools)	
Lawson, Alden B., Lubricating bottom guide bars	91*
Lawson, Alden B., Reclaiming boiler lagging	41*
Lawson, Alden B., Reclaiming journal box packing	129*
Laying out, Special man for	501§
Lee, Ivy L., Address at Master Boiler Makers' convention	313
Lee, J., Device for bending meat hooks	378*
Lee, J., Dies for forging running board saddles	475*
Lehigh Valley, High capacity well car	75*
Lehigh Valley locomotive	112§
Lehigh Valley locomotive, Turning effort of	225†
Lehigh Valley locomotive, 4-6-2 type	117*
Lehigh Valley, Metal pilot on	513*
Lehigh Valley tender tank	72*
Lenox Machine Co., Serpentine shear	207*
Lettering, Standard for freight cars, report at Painters' convention	530
Lewis, B. N., An efficient wheel shop	33*
Lifting device, Vacuum	312*
Lighting fixture, Semi-indirect, for car	1312*
Lima Locomotive Corporation, Austin trailing truck	382*
Lima Locomotive Corporation, Pulverized coal plant	95*
Limitations of the designer	451§
Links, swing, Why do we incline?	4†

## Locomotive

Appliances, Some English	512*
Ash pan air openings	277§
Boiler, B. & O. 2-10-2 type	456*
Boiler construction	1453§
Boiler feed water, Pre-heating	290*
Boiler inspection	13*
Boiler lagging, Reclaiming	41*
Boiler, P. R. R. 4-4-2 type	64*
Boiler, P. R. R. 2-8-2 and 4-6-2 types	343*
Boilers, Circulating system for	645*
Boilers, Patching according to law, by Geo. G. Lynch	634*
Boilers, Strength of	111§
Boilers, Strength of, by William N. Allman	123*
Brake equipment, Traveling Engineers' Association	508*
Brake shoe, Constant service wheel truing bumper, Cast steel with friction draft gear	328*
By-pass drifting valve, D. L. & W.	544*
Cab, Vestibule, Can. Pac.	169*
Combustion chambers, Master Boiler Makers' convention	317
Compound	175
Compound, Will the be revived?	538§
Crank pin, Hollow main, Pennsylvania	67*
Crank pin location, Maximum permissible error in	348*
Cylinders, Drilling the smokebox flanges of	319*
Design during 1913	15
Designing to suit conditions	450§
Driving boxes, Reclaiming cast steel, A. C. L.	375*
Driving wheel tires, Depth of cut for turning	322
Driving wheel tires, Turning, by M. Flanagan	281*‡
Efficient cleaning of	609§
Efficient operation of, T. E. A.	509*
Electric data	415
Energy in a, Distribution of	414
Engine truck, Wedge type, Can. Pac.	169*
Equalization on P. R. R. 4-4-2 type	66*
Fireboxes, Autogenous welding in, by N. H. Ahsiuoth	149*
Firebox riveting, by N. H. Ahsiuoth	191*
Fire door, Ann Arbor R. R.	104*
Fire door, Gravity	550*
Firing practice	290
Firing up at engine houses	636
Front end design	284*
Front ends, 1853-1913, by C. T. Kommel	617*
Four cylinder	1§
Fuel economy	222§
Grates, Air openings of	284*
Grease plug, Locked	50*
Headlight equipment, Installing electric	145*

## Locomotive (Continued)

Headlights, M. M. Association	1457*
Improvements in	2§
Increasing efficiency with hand firing	458
Inspection and work schedules, Can. Pac.	193*
Internal combustion	30†
Lehigh Valley	112§
Lehigh Valley, Turning effort of	225†
Mileage and repair records for Can. Pac.	191
Oil burning, Radial stays in the crown sheets of	318
On curves	357*
Pacific type, I1gh power	611§
Painting, by Milton L. Sims	641
Pennsylvania Atlantic type	588§
Performance, Predetermination of	458*
Pilot, Metal on the Lehigh Valley	513*
Piston rod, Hollow, P. R. R.	66*
"Puffing Billy," Weight of	200†
Recent development	1406§
Repair notes	198*
Repairs, Schedules for	165§
Running boards, Step for, by William G. Landon	281*‡
Running repairs, Notes on present day	247
Screw reverse gear, P. R. R.	67*
Side rods, Cutting jaws in, N. & W.	432*
Single driver in Great Britain	72†
Speed of early	54†
Spring rigging repairs, C. & O.	374*
Standard scale	262*
Starting power of a, by George S. Chiles	5*
Steam, of today, report at the A. S. M. E.	571
Stoker, Improved Hanna	205*
Stoker, Street type C	260*
Stokers, M. M. Association	1434
Stokers, T. E. A.	507
Superheater, Packing for	396‡
Superheater performance, Tests of, P. R. R.	230*
Superheater, Pyrometer for	157*
Superheaters, M. M. Association	1466*
Superheaters, Progress of	1453§
Superheaters, The discussion on	1454§
Tabular comparison, 2-8-2 type	350
Tabular comparison, 2-8-0, 2-10-2 and Mallet types	351
Tabular comparison of 4-4-2, 4-6-0, 2-6-0 and switching types	176
Tabular comparison of 4-8-2 and 4-6-2 types	177
Tanks, Removing paint from	93
Tender coal passer	442*
Tender tank, Lehigh Valley	72*
Tender truck, New, P. R. R.	67*
Tender truck, Structural steel	542*
Tender wheels, Service record of Chrome-Vanadium steel	493*
Tenders, Coal space and adjuncts of, Fuel Association convention	290
Throttle and reverse lever with roller friction clutch	101*
Tires, method of changing, C. & O.	374*
Tires, Service of Vanadium steel	175*
Tool equipment	478*
Track exhibit	1411*
Trailer truck and equalizer, P. R. R.	65*
Trailer truck, Austin, Lima Locomotive Corporation	382*
Truck, Economy	154*
Truck, engine and tender, Recent designs of	539*
Valve gear, A few facts about, by I1al B. Stafford	461
Valve gear, class E6s, P. R. R.	68*
Valve gear, Southern	46*
Valve gear, The Young	403*
Valves, cylinders, crossheads and guides	411
Water gage, Reflex, with metal encased glass	542*
Watering the rails to prevent slipping	178
2-8-2 type, Can. Pac.	169*
2-8-2 type, Efficiency of the	558§
2-8-2 type, L. & N.	1471*
2-8-2 type, P. R. R.	343*
2-8-8-2 type (triple), Erie	221§
2-10-2 type, B. & O.	456*
4-4-2 type, P. R. R.	63*
4-6-2 type, C. & O.	614*
4-6-2 type, Lehigh Valley	117*
4-6-2 type, L. & N.	1471*
4-6-2 type, Paris, Lyons & Mediterranean	298
4-6-2 type, P. R. R.	343*
Locomotive Stoker Co., Street type C stoker	260*
Locomotive Superheater Co., Pyrometer for locomotives	157*
Locomotive Superheater Co., Soft metal grinders for superheater units	549*
Logarithmic co-ordinate paper, Advantages of, by Towson Price	120*
Logarithms, Invention of	487†
London & Northwestern, Discipline on	246†
Long Island, Steel baggage car	517*
Louisville & Nashville, Air valve gages	258*
Louisville & Nashville, Feed valve test rack	202*
Louisville & Nashville, Repairing air pump governors	373*
Louisville & Nashville, Repairing slide valve feed valves	141*

Louisville & Nashville, 2-8-2 type and 4-6-2 type locomotives	1471*
Lowder, R. S., Chadwick mail car faucet	599*
Lowder, R. S., Reflector for observation car windows	310*
Lubricator, Automatic flange, Detroit Lubricator Co.	383*
Lubricator, Four-speed flange	600*
Lubricator, Graphite	602*
Lubricators, Flange, by Robert W. Rogers	293*
Lubricators, Test rack for examining, C. & N. W.	152*
Ludington, C. F., Uniform methods of computing fuel consumption	286*
Lumber, Uniform grading and inspection of, Storekeepers' convention	295
Lynch, Geo. G., Patching boilers according to law	634*
Lyons, Walter D., Special tools in machine shop	89*

## M

MacBain, D. R., Address at M. M. convention	1431*
McCabe, J. J., Double spindle lathe	543*
McCaslin, A. W., Safety fire quencher for blacksmith shops	601*
McCoy, George E., Adjustable platform for car shops	200*
McCrosky Reamer Co., Variable speed and reversing attachment for drills	209*
McDonald, J. W., Forging machine dies	639*
McDonald, J. W., Tools and formers	482*
McGee, W. A., Steel ends for box cars	190*
McManamy, Frank, Address at T. E. A.	506
McManamy, Frank, Address at Master Boiler Makers' convention	314
McManamy, Frank, Locomotive boiler inspection	13*
Machine shop, Tool cabinet for	424*
Machine tool repairs, report at Tool Foremen's convention	431

## Machine Tools

Band saw for cutting metal	490*
Boring and turning mill, Niles	210*
Boring, milling and drilling machine, Horizontal, Bement	489*
Boring mill, Driving box, Gisholt	439*
Boring mill, Side head	1503*
Countersinking machine	104*
Cutting off and reaming machine for pipes and tubes, Oster	268*
Drill, Duntley electric	491†
Drill, Electric hand	327*
Drill, Four spindle radial	99*
Drill, Geared	48*
Drill, High speed	153*
Drill, Large radial, for heavy duty	331*
Drill, Locomotive frame, Newton	649*
Drill, Mud ring and flue sheet	208*
Drill, Portable electric	441*
Drill, radial, Heavy duty, Fosdick	158*
Drill, Variable speed and reversing attachment for	209*
Drilling machine, Horizontal	326
Drills, Pneumatic, equipped with roller bearings	102*
General efficiency, by George W. Armstrong	255*
Grinder, portable, for planer, Stockbridge	156*
Grinder, Portable radial swing	329*
Grinding machine of the open side planer type	330*
Grinding machine, link, Newton	268*
Grinding wheels, Protection of	88
Grinding wheel stand, Norton	381*
Lathe, axle, Bridgford gap	203*
Lathe center grinder	494*
Lathe, Cross-slide flat turret	45*
Lathe, Double spindle	543*
Lathe, Journal truing and axle turning	1275*
Lathe, vertical turret, Machining pistons on a, A. C. L.	92*
Milling machine, Heavy duplex, Newton	384*
Milling machine, portable, Pedrick	266*
Planer, Cincinnati cylinder	210*
Planer, Convertible open side	48*
Planer for heavy work, Pond	323*
Planer for locomotive frames, Niles	438*
Planer, Reversible motor driven, Cincinnati	1504*
Planer, Standard 48 inch, Detrick & Harvey	211*
Planer, 84 inch, Cincinnati	102*
Shaper, Heavy service, American	327*
Shaper, Vertical, Pratt & Whitney Co.	385*
Shear, Lenox serpentine	207*
Slotting machine, Motor driven	601*

Maier, Charles, Training men for engine house work	127
Manchester, A. E., Address at Master Blacksmiths' convention	481
Markel, Charles, Check nut for hose connections	377*
Master Blacksmiths' convention	449§
Master Boiler Makers' Association (see Boiler Makers' Association)	
Master Boiler Makers' Association (see also Meetings)	

Master Car Builders' Association as an investment ..... 1453§  
 Master Car Builders' Association, Young men in ..... 1383§  
 Master Car Builders' Association (see also Meetings).  
 Master Car and Locomotive Painters' Association (see Painters' Association).  
 Master Car and Locomotive Painters' Association (see also Meetings).  
 Material, Centralized manufacture of, on the Frisco ..... 593\*  
 Material, Purchasing ..... 611§  
 Material, Reclaiming ..... 1405§  
 Material, Reclaiming, on the Frisco ..... 501§  
 May, H. C., Draft gear, The essentials of a good ..... 465  
 Mechanical associations, Co-operation among ..... 1357§  
 Mechanical department records ..... 450§  
 Mechanical organizations, Minor, by Angus Sinclair ..... 1470  
 Mechanical stoker, The ..... 1428§  
 Mechanical stoker, The future of ..... 1427§  
 Mechanical stokers ..... 507  
 Mechanical stokers for locomotives ..... 1405§

**Meetings**

Air Brake Association ..... 106, 271, 388  
 American Foundrymen's Association and American Institute of Metals ..... 444, 496  
 American Railway Master Mechanics' Association ..... 604  
 American Railway Tool Foremen's Association, The ..... 160, 389  
 American Society of Mechanical Engineers ..... 106, 604  
 American Society for Testing Materials ..... 334  
 Canadian Railway Club ..... 334  
 Car Foremen's Association of Chicago, and Chief Interchange Car Inspectors' and Car Foremen's Association ..... 214, 389, 444  
 Industrial Welfare and Efficiency Conference ..... 553  
 International Association for Testing Materials, Seventh Congress of the ..... 389, 653  
 International Engineering Congress ..... 214, 653  
 International Railroad Master Blacksmiths' Association ..... 334, 444  
 International Railway Fuel Association ..... 272, 388  
 International Railway General Foremen's Association ..... 52, 334, 388, 389, 653  
 Master Boiler Makers' Association ..... 106, 272, 444, 604  
 Master Car Builders' Association ..... 106, 272, 444, 604  
 Master Car and Locomotive Painters' Association ..... 444, 496  
 National Association of Corporation Schools ..... 1262  
 Niagara Frontier Car Men's Association ..... 272  
 New England Railroad Club ..... 214  
 New Haven Railroad Club ..... 214  
 New York Railroad Club ..... 653  
 Railway Business Association ..... 160  
 Railway Electrical Engineers' Association ..... 1386  
 Railway Storekeepers' Association ..... 160, 214, 271, 553  
 Railway Supply Manufacturers' Association ..... 214, 604  
 Traveling Engineers' Association ..... 334, 496  
 Western Railway Club ..... 160, 334

Men, The relations between foremen and Merchants Despatch Transportation Co. Dairy refrigerator car ..... 308\*  
 Meter, High pressure volumetric air ..... 331\*  
 Mexico, Armored cars for ..... 464\*  
 Milburn Co., Alexander, Oxy-acetylene welding and cutting torches ..... 266\*  
 Miller, B. E., Paint shop apprenticeship system ..... 529  
 Miller, R. N., Questions for car designers ..... 282‡  
 Milling cutter for sharpening driving wheel lathe tools ..... 434\*  
 Milling cutter spacing collar, Adjustable ..... 158\*  
 Milling machine (see also Machine Tools).  
 Milling machine efficiency, by Owen D. Kinsey ..... 593\*  
 Milwaukee Refrigerator Transit & Car Co., Dairy refrigerator car ..... 367\*  
 Minneapolis, St. Paul & Sault Ste. Marie, An efficient wheel shop, by B. N. Lewis ..... 33\*  
 Modern Drop Pit Co., Car wheel drop pit ..... 100\*  
 Modern Machine Tool Co., Cross-slide flat turret lathe ..... 45\*  
 Montreal Locomotive Works, Locomotive, 2-8-2 type, Can. Pac. ..... 169\*  
 Morrison, C. J., Abrasive wheels ..... 40  
 Morrison, C. J., College men and the railroads ..... 11  
 Motive power, Conservation of ..... 222§  
 Motors, Electric in shops ..... 1442  
 Mounce, R. S., Tools for locomotive repairs ..... 143\*  
 Mounce, R. S., Triplex locomotive for Erie Mudge & Co., Car ventilator ..... 227\*  
 Mudge & Co., Refrigerator car door fixtures ..... 548\*  
 Mummert-Dixon Co., Portable radial swing grinder ..... 49\*  
 Mummert-Dixon Co., Portable radial swing grinder ..... 329\*  
 Murdoch, John C., Efficiency in a modern engine house ..... 642

Murray, E. A., Hot water boiler washing system ..... 371\*  
 Murray, E. A., Method of making brake shoe keys ..... 197\*

**N**

National Association of Corporation Schools (see also Meetings).  
 National Malleable Castings Co., Frictionless return roller side bearing ..... 384\*  
 National Railway Equipment Co., Dust guard Nut & Smith Electric Tool Co., Portable electric grinder ..... 640\*  
 New England Railroad Club (see also Meetings).  
 New Haven Railroad Club (see also Meetings).  
 New York Central & Hudson River, Steel underframes for use on wooden freight cars ..... 494\*  
 New York Central Lines, Goggles in railway shops ..... 515\*  
 New York Central Lines, Steel truck with clasp brake rigging ..... 488\*  
 New York, New Haven & Hartford, Steel coach ..... 359\*  
 New York Railroad Club ..... 185\*  
 New Zealand, Government railways ..... 653  
 Newhall Engineering Co., George M., Gravity boiler washing system ..... 47†  
 Newman, C. M., Improved tool holder and center for wheel lathes ..... 361  
 Newman, C. M., Machining pistons on a vertical turret lathe ..... 545\*  
 Newton Machine Tool Works, Heavy duplex milling machine ..... 142\*  
 Newton Machine Tool Works, Link grinding machine ..... 92\*  
 Newton Machine Tool Works, Locomotive frame drill ..... 268\*  
 Newton Machine Tool Works, Motor driven slotting machine ..... 649\*  
 Niagara Frontier Car Men's Association, Packing and lubricating journals ..... 601\*  
 Niagara Frontier Car Men's Association (see also Meetings).  
 Niles-Bement-Pond Co., Boring and turning mill ..... 369  
 Niles-Bement-Pond Co., Boring, milling and drilling machine ..... 210\*  
 Niles-Bement-Pond Co., Journal truing and axle turning lathe ..... 480\*  
 Niles-Bement-Pond Co., Planer for heavy work ..... 1275\*  
 Niles-Bement-Pond Co., Planer for locomotive frames ..... 323\*  
 Niles-Bement-Pond Co., Side head boring mill ..... 438\*  
 Noland, Geo. W., Modern train building ..... 1503\*  
 Norfolk & Western, Cutting jaws in locomotive side rods ..... 303  
 Norfolk & Western, Cylinder cocks, Tools for finishing ..... 432\*  
 Norfolk & Western, Road tests of Schmidt superheater and brick arch ..... 432\*  
 Norman, R. A., The college man and the railroads ..... 1497  
 Northern Engineering Works, Portable electric hoist ..... 168§  
 Northern Fire Apparatus Co., Fire extinguisher ..... 267\*  
 Northern Pacific stock car ..... 212\*  
 Norton Co., Grinding wheel stand ..... 181\*  
 Norton Co., Protection of grinding wheels ..... 381\*  
 Norway, Electrifying railways in ..... 8†  
 Nut lock washers, Dies for making, P. R. R. ..... 640\*

**O**

Oil and gasoline pumps, Long distance ..... 330\*  
 Oil burner, Erie ..... 253\*  
 Oil burner, Fuel ..... 600\*  
 Oil engines for low grade fuel ..... 494\*  
 Oil furnace, Water jacket door for ..... 143\*  
 Oil welding ..... 584\*  
 Operation and equipment, Regulation of ..... 1260§  
 Operation of locomotives, Efficient, T. E. A. convention ..... 509\*  
 Organization and efficiency, Car department ..... 235  
 Organization, Minor mechanical ..... 1470  
 Oster Manufacturing Co., Cutting off and reaming machine ..... 268\*  
 Oxy-acetylene and electric welding, Boiler Makers' convention ..... 314  
 Oxy-acetylene, Malleable iron welded by ..... 546\*  
 Oxy-acetylene process, Use at reclamation plant of St. L. & S. F. ..... 531\*  
 Oxy-acetylene welding and cutting, report at Blacksmiths' convention ..... 485  
 Oxy-acetylene welding and cutting torches ..... 266\*  
 Oxy-acetylene welding applied to manufacturing ..... 325\*  
 Oxy-acetylene welding ..... 583\*  
 Oxygen testing apparatus ..... 649\*

**P**

Packing for superheater locomotives ..... 306‡  
 Packing, metallic, Handling in roundhouses ..... 504‡  
 Packing, Metallic, troubles ..... 280‡  
 Packing, Reclaiming journal box, by Alden B. Lawson ..... 129\*  
 Paddock, C. E., Tool cabinet for the machine shop ..... 124\*

Paint, Removing, by sand blast ..... 530  
 Paint, Rust inhibitive, report at Painters' convention ..... 529  
 Paint shop apprenticeship system ..... 529  
 Paint shop, Saving time in the, B. & M. ..... 94\*  
 Painting locomotives and steel cars, by Milton L. Sims ..... 641  
 Painting steel car doors, P. R. R. ..... 643  
 Pantasote Co., Agasote ..... 1433†  
 Parks, O. J., Hot boxes ..... 299  
 Parr, S. W., Clinker and honeycombs formation ..... 283  
 Patch bolts, Tools for applying ..... 434\*  
 Pearce, E. S., Draft gear performance ..... 461\*  
 Pedrick Tool & Machine Co., Pipe bending machine ..... 491\*  
 Pedrick Tool & Machine Co., Portable milling machine ..... 266\*  
 Peffers, A. Roy, Air hose protector ..... 153\*  
 Pennsylvania brake tests ..... 115§  
 Pennsylvania Lines West of Pittsburgh, Hot boxes ..... 299  
 Pennsylvania Railroad, Brake tests on passenger trains ..... 136\*  
 Pennsylvania Railroad, Forging machine dies ..... 639\*  
 Pennsylvania Railroad, Classification of coach repairs ..... 529  
 Pennsylvania Railroad, Gas producer at Juniata shops ..... 437\*  
 Pennsylvania Railroad, Heavy duplex milling machine ..... 384\*  
 Pennsylvania Railroad, Lunch counter car ..... 22\*  
 Pennsylvania Railroad, Painting steel car doors ..... 643\*  
 Pennsylvania Railroad, Steel box car ..... 419\*  
 Pennsylvania Railroad, Steel cahoose ..... 577\*  
 Pennsylvania Railroad, Superheater tests ..... 222§  
 Pennsylvania Railroad, Tests of superheater performance ..... 250\*  
 Pennsylvania Railroad, 2-8-2 and 4-6-2 type locomotive ..... 213\*  
 Pennsylvania Railroad locomotive, 4-4-2 type ..... 63\*  
 Perritt, J. F., Smith shop tools ..... 148\*

**Personals—General**  
*(Above grade of Master Mechanic)*

Adams, A. C. .... 335  
 Arter, Wilbur D. .... 273  
 Barnum, M. K. .... 497\*  
 Billingham, Joseph ..... 497, 605  
 Bingham, C. A. .... 161  
 Bosworth, W. M. .... 161, 215  
 Cockfield, H. .... 335  
 Collett, R. .... 53  
 Cox, Millard F. .... 215  
 Cromwell, E. G. .... 273  
 Destiche, C. O. .... 389  
 Drysdale, W. F. .... 53  
 Duer, J. V. B. .... 53  
 Dunn, J. F. .... 215  
 Earlywine, R. C. .... 497  
 Elmes, C. C. .... 161  
 Epler, J. E. .... 497  
 Fitzsimmons, E. S. .... 553  
 Gardner, J. C., Jr. .... 53\*  
 Garstang, William ..... 53\*  
 Gill, C. A. .... 273  
 Hainen, J. .... 445  
 Hall, E. B. .... 107, 161  
 Heinzelman, T. W. .... 161  
 Henry, J. M. .... 53  
 Hinkley, A. C. .... 335\*, 389  
 James, Charles ..... 553  
 Kinyon, Alorzo G. .... 445  
 Kuhn, Wm. T. .... 389  
 Malone, W. H. .... 273  
 Miller, W. J. .... 553  
 Mosley, W. S. .... 497  
 Mullen, D. J. .... 161, 273  
 Murphy, F. K. .... 273  
 Nolan, J. C. .... 335  
 Osborne, H. .... 161  
 Osborn, J. .... 161  
 Ottavitt, H. C. .... 107  
 Pack, A. G. .... 107, 161\*  
 Prendergast, A. P. .... 215  
 Preston, R. .... 497  
 Reynolds, H. E. .... 335  
 Richardson, T. A. .... 215, 273  
 Ricketson, W. E. .... 445  
 Ripley, C. T. .... 215  
 Ruxton, J. H. .... 215  
 St. Pierre, George ..... 445\*  
 Sasser, E. C. .... 107  
 Sasser, J. W. .... 53, 389  
 Shoemaker, Harvey ..... 161  
 Small, H. J. .... 335  
 Stewart, R. L. .... 654  
 Sullivan, J. J. .... 553  
 Trumbull, A. G. .... 553  
 Van Alstyne, David ..... 553  
 Younger, T. W. .... 161  
 Walsh, F. O. .... 161  
 Wood, P. O. .... 53, 273  
 Woodhouse, W. E. .... 161

**Personals—Master Mechanics and Road Foremen of Engines**

Apted, Wm. .... 161  
 Ashmore, C. D. .... 107  
 Baer, Mark ..... 273  
 Baker, Wm. .... 107  
 Parker, J. A. .... 107

Page numbers under 1,000 refer to *Railway Age Gazette, Mechanical Edition*; those over 1,000 refer to the *Daily Railway Age Gazette*. \* Illustrated article; † editorial; ‡ short non-illustrated article or note; § communication.



Personals—Master Mechanics and Road Foremen of Engines (Continued)

Barnhill, C. F.	215, 273
Barrow, A.	215
Bauer, John	215
Bauer, F.	215
Beltz, J. D.	107
Benzies, John	107
Billingham, R. A.	335
Binns, A. H.	335
Boardman, F. W.	107
Bohneau, W. W.	335
Booth, H.	273
Bowersox, Charles	54
Brandt, C. A.	215
Burgess, G. F.	605
Butler, W. S.	101
Carey, J. J.	161, 335
Cassidy, J. A.	107
Clough, D. C.	101
Colligan, P. J.	335
Cooper, W. G.	215
Coots, J.	215
Crance, H. A.	335
Crowley, B. F.	107
Cunneen, J.	73
Curley, W. A.	107
Davies, W. H.	161
Deveny, F. S.	107
Deveny, W. D.	497
Dickson, John	161, 335
Dole, J. G.	107, 162
Donnelly, J. R.	605
Dressel, W. H.	215
Eddy, W. J.	162
Elmes, C. C.	54
Firmhaber, A. H.	335
Fowler, C. E.	335
Gage, G. N.	107
Gallagher, G. A.	215
Gallagher, Hugh	445
Garrett, E. J.	107
Glasford, G.	497
Graf, W.	335
Gratton, David	389
Gregory, C. F.	215
Guid, A.	389
Hall, W. A.	162
Hallman, John	335
Hamilton, L. F.	215
Hamm, F. A.	335
Hammond, R. E.	389
Hayes, H. B.	654
Heapes, F.	335
Hickey, D.	445
Highleyman, J. W.	273
Hobran, M. P.	335
Hobson, W. P.	162
Hoffman, W. H.	215
Hollman, J. M. O.	389
Horan, John	389
Hudson, T. C.	497, 605*
Huffman, C. M.	162
Hyde, R. C.	162
Ironsides, A. J.	497
Keiper, J. I.	107
Kerr, John	497
Kilfoyle, J. M.	553
Kilgore, W. B.	215
King, A. F.	215
Klumb, A. J.	162
Kugler, H.	107
Lanon, Wm.	107
Lemieux, E. J.	605
Lloyd, W. J.	215
Lovell, W. T.	335
Lowe, T. S.	497
Luscombe, J. T.	335
McClain, T.	335
McGraw, M. J.	215
McHattie, T.	605
McLeod, T. R.	497
McMillan, A. E.	335
Mahon, J. W.	215
Malone, D. J.	215, 389
Manley, Charles	553
Markey, J.	605
Marshall, John A.	497
Mayo, Frank W.	54
Moher, W. E.	654
Montgomery, M. S.	273
Moore, W. C.	497
Muchmore, Harry M.	605
Murphy, F. W.	335
Murray, P. H.	553
Naylor, William	215
Neill, J. W.	107
Neish, J. B.	389
Nicholson, F.	215
Nicholson, T.	107
O'Brien, William	497
O'Connor, J.	107
Parker, H. H.	107
Patterson, S. T.	107
Peers, A.	335
Pennyfather, F. R.	162
Powers, B.	107
Randall, C. B.	107
Rennix, W. J.	215, 497
Richardson, B. D.	335
Roberts, James	273
Robertson, Edward	107
Robertson, G. W.	162
Roesch, A.	162

Personals—Master Mechanics and Road Foremen of Engines (Continued.)

Ross, George	215
Rowe, R. E.	336
Rukel, L.	215
Sample, W. H.	605
Schepp, J. C.	389
Searle, George	553
Sheafe, J. S.	215
Sheppard, J. A.	336
Showell, L.	54
Shull, G. F.	497
Sinnott, W.	273
Smith, P.	336
Snyder, W. H.	553, 605*
Staley, H. F.	654
Stevens, Oscar	336
Stewart, G. K.	336
Stormer, W. E.	162
Stohberger, Philip	54
Stone, F.	390
Strauss, B.	215
Sturrock, A.	654
Sweeley, E. A.	445
Tate, M. K.	273
Thibaut, George	553
Tschuon, J. A.	215
Wolfe, F. E.	162
Wolfe, T. E.	215
Wood, J. H.	605
Wood, Robert E.	215
Woster, L.	215
Watters, J. H.	107
Wicks, William V.	553
Wilson, F. W.	107
Wilson, J. E.	215
Wilson, W. M.	336
Yeaton, C. S.	605

Personals—Car Department

Anderson, Oscar	107
Argue, G. M.	336
Bieber, John A.	554
Brendel, J. P.	336
Burcher, C. M.	54
Butler, T. J.	654
Cantwell, J. L.	654
Carleton, R. V.	54
Chubb, A. J.	554
Cooper, J. S.	107
Davey, T. S.	553
Dorner, H. I.	215
Edmonds, F. H.	107
Flaherty, B.	554
Fletcher, J.	107
Fox, Frank L.	554
Gouge, F.	497
Griffin, H. C.	336
Hadley, W. H.	554
Harper, F. J.	54
Hartough, E. W.	107
Hawkins, J. H.	107
Hawkins, J. M.	390
Heim, F.	336
Helwig, P. W.	273
Hennessey, G. F.	107
Hessenbruch, T. E.	162
Hodgson, J.	497
Holcomb, Dahl	54
Jones, N. B.	390
LaMasters, T. D.	445
Leake, J. F.	654
LeFebres, W. D.	554
Lilly, B. F.	273
Linder, W. C.	107
Lyle, W. D.	654
McArthur, C. R.	108
McLean, George	108
McMunn, William R.	605
Mack, H.	273
Martin, W. A.	336
Mase, C. F.	107
Moore, J. A.	216
Nell, S. E.	554
O'Brien, G. H.	54
O'Neal, I.	273
Olson, Peter	554
Ord, L. C.	273
Orr, B. F.	390
Page, S. D.	216
Pinson, W. H.	216
Pritchard, R. W.	54
Ramsdell, T. M.	336
Rasbridge, R. B.	162
Ray, Charles	162
Reeve, F.	54
Schmalzried, William	554
Shaw, O. E.	606
Snell, W.	162
Summers, F. T.	108
Sweetman, A. H.	273
Tetu, A. L.	336
Weigman, W. F.	654
White, H. J.	497
Wilson, R. D.	273
Woodhouse, W.	54
York, H. K.	390
Zerbach, H. H.	162
Zweibel, C. A.	554

Personals—Shop and Engine House

Aitken, J.	336
Alaman, H.	216

Personals—Shop and Engine House (Continued)

Allen, H.	54
Anderson, A.	554
Andrews, W. J.	336
Anthony, F. S.	108
Armstrong, J. L.	445
Barnwell, E. A.	54
Bayham, C. H.	445
Belyea, Wm.	162
Bentley, F. W., Jr.	445
Bingham, G. C.	162
Black, R. L.	162
Black, W. F.	216
Bladorn, F. A.	336
Boertman, Charles	216
Boline, L. E.	108
Boswell, F. A.	445
Braun, Otto	497
Brimacombe, G.	336
Brown, T. L.	162
Burleigh, W. H.	654
Carleston, J. A.	390
Chapman, Lee	108
Chrysler, E. E.	554
Clarke, F.	273
Clary, L.	336
Connors, J. L.	606
Cooney, J. P.	108
Cooper, F. E.	497
Copp, C. E.	273
Cossar, D. D.	390
Costello, J. G.	336
Cull, Wm. A.	108
Cunningham, A. J.	108
Davidson, J. E.	606
Day, D. W.	162
Deems, W. A.	216
Dehn, B. D.	273
Denne, G. F.	336
Dennis, R.	162
Drolet, G.	336
Evans, E. E.	273
Ferris, B.	162
Fife, C.	216
Findlay, J. W.	498
Fisher, F.	336
Fitzgerald, Charles	274
Flynn, P. J.	162
Fritts, Joseph	498
Fryant, C. R.	108
Forsberg, H. P.	216
Foster, G. T.	54
Gallup, W. F.	336
Gardner, Henry	274, 336
Gardner, R.	606
Gaston, James H.	216
Giles, J. E.	54
Gray, E. P.	54
Green, J. F.	606
Greenwood, B. E.	390
Greiner, R. J.	336
Hall, R. H.	498
Halsey, W. H.	108
Hanse, E. C.	274
Harris, P.	554
Harvard, J. B.	336
Haslet, J. B.	108
Hayward, W. E.	606
Heinbach, W. F.	390
Hendricks, L. W.	445
Hoffman, L. L.	554
Honan, J.	54
Hutchins, R. D.	336
Johnson, Chas.	54
Johnson, F.	390
Keller, W. H.	216
Krabbenhof, H.	554
Kubeck, F.	336
Lawhon, A. M.	654
Lawhon, N. J.	216
Lodor, Albert	108
Logan, G. H.	108
Long, Thomas	336
Lozo, F.	162
Lynch, Charles	216
McCharles, A. D.	336
McClellan, A. G.	216
McCue, Edward	336
McCue, T.	606
McDonald, D. G.	54
McDonough, J. W.	108
McHardy, H.	54
McLean, C.	336
McPherson, W. G.	54
Mack, C. D.	54
Maddieck, J. A.	54
Maham, A. H.	162
Maher, Frank	606
Maitland, A. J.	336
Marley, F. M.	336
Martyr, H. F.	216
Martz, M. E.	274
Marx, Emil	274
Mcgalis, C. L.	274
Mennie, R. S.	108
Milholland, J. K.	274
Miller, M.	445
Miller, R. A.	498
Milton, W. P.	336
Morton, J.	54
Murphy, J.	108
Myers, J. Q.	216
Nash, T.	108

Page numbers under 1,000 refer to Railway Age Gazette, Mechanical Edition; those over 1,000 refer to the Daily Railway Age Gazette. \* Illustrated article; † editorial; ‡ short non-illustrated article or note; † communication.



Personals—Shop and Engine House (Continued)

Norsworthy, N. W. 162  
 Olson, S. 108  
 Orth, J. H. 654  
 Peasley, B. J. 336  
 Pentland, A. J. 390  
 Phalen, D. P. 336  
 Phillips, F. A. 336  
 Poole, L. J. 336  
 Pratt, G. 336  
 Purcell, Thomas 336  
 Quinlan, Dennis 54  
 Rauch, H. S. 216  
 Reed, J. 54  
 Reid, H. J. 336  
 Revana, Frank 274  
 Rhinehard, C. W. 274  
 Robertson, C. W. 274  
 Rowley, H. C. 216  
 Sarney, C. E. 336  
 Schimming, George 162  
 Schoenky, O. B. 336  
 Schroeder, G. T. 390  
 Schuman, William 554  
 Simmes, John 216  
 Simpson, F. C. 108  
 Smith, D. E. 654  
 Sproule, R. 445  
 Stamelin, F. 108  
 Stone, J. E. 108  
 Sturrock, A. 390  
 Test, C. E. 274  
 Thomas, G. W. 216  
 Thompson, H. 274  
 Toll, W. 54  
 Torback, F. S. 274  
 Trow, W. B. 654  
 Van Blaricum, C. B. 274  
 Wade, W. 216  
 Warden, H. M. 216  
 Watkins, D. S. 336  
 Weir, James 336  
 Welch, Roy 54  
 Wells, W. 390  
 Wilkins, J. A. 216  
 Willis, F. L. 390  
 Witte, H. 108  
 Wortman, W. 390  
 Wright, A. S. 654

Personals—Purchasing and Storekeeping

Angier, F. J. 216  
 Baldwin, C. D. 445  
 Barker, T. H. 216  
 Baxter, Ernest 390  
 Blackburn, R. M. 216  
 Boice, C. D. 216  
 Calhoun, F. B. 498  
 Clark, S. F. 162  
 Cooley, LeRoy 498  
 Craig, C. R. 216  
 Dawley, A. A. 445  
 Dawson, W. R. 336  
 Dickinson, W. A. 498  
 Donaldson, D. L. 274  
 Dunlop, W. J. 216  
 Fitzgerald, F. A. 336  
 Fleisch, G. J. 498  
 Fries, E. L. 445  
 Griffith, E. O. 162  
 Hallenbeck, H. E. 554  
 Hayden, G. W. 274  
 Hickey, W. P. 274  
 Hoyer, J. F. 216  
 Hukill, Henry O. 446  
 Lefraivire, W. E. 216  
 McQuilkin, H. P. 274  
 McQuilkin, O. V. 336  
 Martin, H. B. 390  
 Mayhall, J. V. 554  
 Murphy, F. A. 274  
 Neiswinter, Ira 445  
 Nelson, O. 654  
 Orndorff, J. R. 54  
 Phelps, W. G. 498  
 Preston, Earl 498  
 Ray, H. E. 554  
 Richardson, H. L. 162  
 Robinson, G. H. 216  
 Robson, S. H. 606  
 Roth, E. J. 274  
 Sanford, J. H. 554  
 Sanl, G. W. 445  
 Scott, George E. 445  
 Secor, G. A. 498  
 Singletary, T. D. 554  
 Snowden, N. R. 498  
 Stewart, K. R. 554  
 Thomon, L. C. 498  
 Thornley, E. W. 274  
 Tillman, C. T. 162  
 Transue, Ray F. 446  
 Turner, J. A. 216  
 Tutwiler, L. H. 274  
 Wachter, A. B. 554  
 Wakefield, O. C. 606  
 Wester, C. M. 554  
 Williams, C. B. 498  
 Williams, W. H. 606  
 Woods, J. L. 54  
 Yuill, A. E. 216

Personals—I. C. C. Appointments

Baumgardner, Fred M. 554  
 Cunningham, A. J. 606  
 McManamy, Frank 107  
 Peters, R. F. 554  
 Thomas, W. J. 606  
 Wells, M. E. 554

Personals—Obituary

Adams, A. B. 162  
 Adams, Thomas E. 554  
 Apps, William 274  
 Bissett, James 654  
 Butze, Adolph 216  
 Chaffee, Frank W. 555  
 Cheney, D. C. 390  
 Davis, Morris 498  
 Drury, C. J. 606  
 Eddington, Walter J. 390  
 Fitzgerald, D. E. 217  
 Frazer, Charles R. 498  
 Gibbs, E. B. 216  
 Gilbert, E. B. 606  
 Idler, D. C. 217  
 Kimball, N. S. 162  
 McCuen, J. P. 606  
 Malone, Daniel J. 446  
 Miller, Darius 498  
 Miller, Jacob C. 498  
 Moran, Robert 498  
 O'Hern, William 274  
 Player, John 498  
 Prince, Samuel F. 446  
 Skinner, John R. 390  
 Stewart, Alexander 274  
 Strong, William B. 499  
 Sullivan, Daniel E. 555  
 Thomas, W. H. 217  
 Warman, Cyrus 274

Philippines, Railway extension 390  
 Piece work for store department 296  
 Piece work system, An efficient, Can. Pac. 249  
 Pilot, Metal, on the Lehigh Valley 513  
 Pipe bending machine, Pedrick 491  
 Pipe cutter (see also Machine Tools)  
 Piston rod, Hollow, Pennsylvania 66  
 Pitard, J. H., Uniform stenciling of freight cars 612  
 Pittsburgh & Lake Erie, Removing paint by sand blasting 530  
 Pittsburgh & Lake Erie, Safety quencher for blacksmith shop 601  
 Planer (see also Machine Tools)  
 Plant for repairing boilers 311  
 Pliers, Adjustable 331  
 Pneumatic press for general work, C. of G. 385  
 Power, Starting, of a locomotive 5  
 Power, Studying the distribution of 278  
 Powers, R. C., Plant for repairing boiler tubes 311  
 Powers, T. F., Chemical treatment of feed water 316  
 Pratt & Whitney Co., Vertical shaper 385  
 Prendergast, A. P., Address at General Foremen's convention 410  
 Press, hydraulic, Pilot operated valve for 44  
 Press, Pneumatic, for general work, C. of G. 385  
 Price, Towson, Advantages of logarithmic co-ordinate paper 120  
 Prices for labor and material, M. C. B. 1303  
 Priebe, H. C., Spring versus friction draft gears 453  
 Prince-Groff Co., Reflex water gage with metal encased glass 542  
 Pump, Triplex hydraulic 323  
 Punch presses, Safety suction device used on 312  
 Purcell, Mark, Caboose air gage and conductor's valve 301  
 Pyle, L. R., Coal space and adjuncts of tenders 290  
 Pyle National Electric Headlight Co., Electric type E equipment 1477  
 Pyrometer for superheater locomotives 157

Q

Q & C Co., Ross-Schofield system of boiler circulation 645

R

Radial stays in the crown sheets of oil burning locomotives 318  
 Railroad between Portland and Quebec 342  
 Railway Appliance Co., Edman box car door 1403  
 Railway Business Association 160  
 Railway Electrical Engineers' Association (see also Meetings)  
 Railway for Iceland 298  
 Railway General Foremen's Association (see General Foremen's Association) 57  
 Railway men, The training of 57  
 Railway Storekeepers' Association (see also Meetings)  
 Railway Supply Manufacturers' Association, Officers and committee 1263  
 Railway Supply Manufacturers' Association (see also Meetings)  
 Railway Supply & Equipment Co., Strainer and drain valve for injector suction pipes 326

Railway Tool Foremen's Association (see Tool Foremen's Association)

Railway Utility Co., Utility honeycomb ventilator 1403  
 Reamer for air pump governor 435  
 Reamers, Standardizing 425  
 Reclaiming scrap material 452  
 Recommendations, Avoid unnecessary 1285  
 Record, A gratifying 1480  
 Record keeping 127  
 Recorder, Graphic service 598  
 Records, Locomotive mileage and repairs on the Can. Pac. 191  
 Reflectors for observation car windows 310  
 Regulation of operation and equipment 1260  
 Repair notes, Locomotive and car, by W. T. Gale 198  
 Repair work at small engine houses, by G. H. Roberts 633  
 Repairs, Classification of coach, for paint shops 529  
 Repairs, Form for noting freight car 526  
 Repairs, Freight car, by C. L. Bundy 179  
 Repairs, running, Notes on present day 247  
 Replacer, Car 1452  
 Reports, Making, for the government 111  
 Returns come fast 1454  
 Revolute Machine Co., Washing and drying machine 265  
 Riley, J. W., Dies for forming wrenches 487  
 Ringleman smoke chart 514  
 Rivet buster, Ingersoll-Rand 648  
 Rivet set retainer for pneumatic hammers 441  
 Riveting, Firebox, by N. H. Ahsioh 191  
 Road foreman of engines, The 59  
 Road foreman's part in preventing failures, The 50  
 Roberts, A. L., Young valve gear 614  
 Roberts, A. M., President's address at Tool Foremen's convention 425  
 Roberts, G. H., Repair work at small engine houses 633  
 Roberts & Schaefer Co., Concrete coaling station 122  
 Robertson, W. M., Burning out oil deposits in air pumps 538  
 Robertson, W. M., Repairing a cut journal 640  
 Rock Island Lines, Device for removing stand pipes 488  
 Rock Island Lines, Grain tight construction for box cars 81  
 Rock Island Lines, Lunch counter car 582  
 Rock Island Lines, Tool clamp for wheel lathe 644  
 Rock Island Lines, Turning crank pins 475  
 Rock Island Lines, Uniform inspection for special loading 463  
 Rod, Locked grease plug for 50  
 Roesch, E. P., President's address, T. E. A. 505  
 Rogers, Robert W., Efficiency 197  
 Rogers, Robert W., Flange lubricators 293  
 Rogers, Robert W., The special apprentice 504  
 Rogers, Robert W., Observations on apprentice schools 373  
 Rogers, Robert W., Reclaiming car axles 644  
 Roller bearings on coaches 28  
 Rommel, C. T., Locomotive front ends, 1853-1913 617  
 Rommel, C. T., Locomotive tool equipment 352  
 Roth, E. J., Efficiency from store department employees 297  
 Roundhouse blower valves, Jenkins Bros. 438  
 Rules for loading materials, recommended changes in, M. C. B. 1366  
 Rules of interchange, revision of, M. C. B. 1300  
 Rules, Shippers and the 1358  
 Ryan, Galloway & Co., Coal passer for tenders 442

S

Safety appliance regulations, Conforming with 1285  
 Safety appliance standards, by R. M. Berg 576  
 Safety appliances 1405  
 Safety appliances, Instructing men on 393  
 Safety Car Heating & Lighting Co., Axle generator suspension 1382  
 Safety Car Heating & Lighting Co., Ceiling fan for passenger car 1403  
 Safety Car Heating & Lighting Co., Metal cutting and welding 263  
 Safety Car Heating & Lighting Co., Semi-indirect car lighting fixture 1312  
 Safety movement in England 655  
 Safety valves, Interval between tests of 13  
 St. Louis & San Francisco, Convertible box and stock car 28  
 St. Louis & San Francisco, Recent developments on 588  
 St. Louis & San Francisco, Reclaiming material on 531  
 St. Louis Southwestern, Engine failures on 292  
 Sand blast for cleaning steel cars, by J. M. Betton 17  
 Sand blast, Removing paint by, report at Painters' convention 530  
 Saw, Hand, for cutting metal 550  
 Scaling, Effect of the method of flue cleaning on, Boiler Makers' convention 318  
 Schedules, Inspection and work, Can. Pac. 193  
 Schmalzind, William, The draft gear problem 467

Page numbers under 1,000 refer to *Railway Age Gazette, Mechanical Edition*; those over 1,000 refer to the *Daily Railway Age Gazette*. \* Illustrated article; † editorial; ‡ short non-illustrated article or note; †† communication.

Schmidt, Anthony, Elliptic spring tables...	356	Shop Kinks (Continued)		Spidy, E. T., Steel freight car repair shops...	131*
Schofield, W. C., Shop kinks.....	486*	Iron storage rack.....	480*	Spring making and repairing.....	483
Scott, W. W., Taylor system.....	413	Jig for boring side rods.....	91	Springs, Tables for designing elliptic.....	356
Scrap material, Reclaiming.....	452‡	Jig for grinding in rotary valves on E-T equipment, C. & N. W.....	42	Squirt hose, Inspirator for.....	325*
Scrap material, Reclaiming, on the Frisco.....	531*	Jig for machining eccentrics, Erie.....	94*	Stafford, Hal B., A few facts about locomotive valve gear.....	461
Screw reverse gear, Pennsylvania.....	67*	Jig for milling flat wrenches, C. of G.....	638*	Stand pipes, Device for removing.....	488*
Seulhin-Gallagher Iron & Steel Co., Boltless truck side frame.....	150‡	Lathing chuck for small work.....	90*	Standard car improvable, by H. H. Vaughan.....	25
Scully-Jones & Co., Adjustable spacing collar.....	158*	Magnetic old man.....	151*	Standard Improved Truck Co., Welded truck.....	325*
Seaboard Air Line, Smith shop tools.....	148*	Mandrel for turning eccentrics.....	143*	Standard practices, Enlarging.....	1427‡
Seal, Automatic car.....	1313*	Meat books, Device for bending.....	378*	Standard Scale & Supply Co., Locomotive scales.....	262*
Seley, C. A., Ventilated all-steel cars.....	24	Milling cutters for wheel lathe tools, Sou. Pac.....	434*	Stays, Crown sheet expansion.....	375*
Sellers & Co., Wm., Injector coupling nut.....	264*	Patch bolts, Tool for applying, Sou. Pac.....	434*	Staybolt, American.....	1477*
Shaft straightener, Hydraulic, Watson-Stillman.....	211*	Pipe bending machine.....	476*	Staybolt chuck.....	547*
Shaper (see also Machine Tools)		Plates for molding metallic packing.....	480*	Staybolts, Flexible, in place of sling stays.....	317
Shaw Electric Crane Co., Monorail system.....	491*	Platform, Adjustable, for car shops, Intercolonial.....	200*	Staybolts, Gages for determining the length of flexible, Can. Pac.....	253*
Shaw Propeller Co., Novel form of wrench.....	156*	Portable rivet forge.....	151*	Steam gages, Interval between tests of.....	13*
Shear (see also Machine Tools)		Pump, Portable test.....	478*	Steam heat, Electric thermostatic control of.....	267*, 1404‡
Shear for cutting short rivets, Can. Pac.....	642*	Racks for painting steel car doors, P. R. R.....	643*	Steel, Carbon and high speed.....	471*
Shearer, E. J., et al., Low water alarm.....	155*	Reamer for Westinghouse air pump governor, C. & A.....	435*	Steel ends for box cars, by W. A. McGee.....	190*
Sheehan, J. J., Special tools.....	432*	Repairing a cut journal, Ill. Cent.....	640*	Steel, Special alloys and heat treated.....	1468*
Shop, B. & M. repair, by F. K. Irwin.....	561*	Repairing slide valve feed valves, L. & N.....	141*	Stenciling of freight cars, Uniform, by J. H. Pitard.....	612‡
Shop, Does this fit your.....	61‡	Right angle attachment for air motors.....	143*	Step for locomotive running boards, by William G. Landon.....	281‡
Shop efficiency, The general foreman and General Foremen's convention.....	410	Roundhouse test rack for examining lubricators, C. & N. W.....	152*	Sterilizer, Portable steam.....	541*
Shop facilities and labor.....	559‡	Scarfing tool for flue sheets, Sou. Pac.....	434*	Stilz, H. B., Fuel oil burner.....	600*
Shop for steel car construction, Can. Pac.....	242*	Shear for cutting short rivets, Can. Pac.....	642*	Stockbridge Machine Co., Portable grinder for planers.....	156*
Shop kinks, report at Blacksmiths' convention.....	486*	Side rods, Cutting jaws in, N. & W.....	432*	Stoker, Improved Hanna.....	205*
<b>Shop Kinks</b>		Slabbing mill, C. of G.....	638*	Stoker, locomotive, Street type C.....	260*
Air hoist and crane.....	480*	Spring rack.....	479*	Stoker, Mechanical.....	1428‡
Air pump governor, Tools for repairing, L. & N.....	373*	Spring rigging and tire repairs, C. & O. Staging, Adjustable, for painting cars, B. & M.....	374*	Stokers, Locomotive, M. M. Association.....	1434
Axles, Method of reclaiming on the Erie Bolt chuck.....	89*	Staysbolts, flexible, Gages for, Can. Pac.....	253*	Stokers, Mechanical, report at T. E. A. convention.....	507
Boring bar head.....	90*	Test rack, Portable combination, C. & N. W.....	378*	Stokers, Mechanical, for locomotives.....	1405‡
Boring head, Three tool.....	89*	Tire heater, Portable, Erie.....	94*	Stokes, W. D., Efficiency from store department employees.....	296
Brake cylinder head gaskets, Clips for holding, C. & N. W.....	380*	Tool clamp for wheel lathes, Rock Island Lines.....	644*	Store department employees, Efficiency from.....	296
Brake shoe keys, A cheap method of making, by E. A. Murray.....	197*	Tool for cutting oil grooves on driving box shoe and wedge faces, C. & A.....	435*	Stores department, Co-operation and the.....	610‡
Brake staffs, Punching holes in, by R. F. Calvert.....	248*	Tool for setting boiler course sheets.....	152*	Storekeepers' Association (see Railway Storekeepers' Association)	
Burner for fuel oil, by H. Blackburn.....	253*	Tool for turning outside surfaces on boring mill.....	91*	Strength of locomotive boilers.....	224‡
Car roofs, Testing for leakage, A. T. & S. F.....	374*	Tool for turning tumbling shafts.....	479*	Stresses in the members of steel box cars, by W. F. Kiesel, Jr.....	23
Car truck transoms, Method of reclaiming.....	198*	Truck for carrying rods.....	479*	Subordinates, The treatment of.....	610‡
Center for wheel lathe, A. C. L.....	142*	Turbine saw and drill.....	479*	Sullivan Machinery Co., Power driven air compressor.....	259*
Circular glass cutter, L. S. & M. S.....	638*	Valve spindles, Jig for repairing.....	198*	Sunday, Billy, and the railroads.....	1414*
Coal, powdered, Plant for preparing, by J. G. Contant.....	254*	Wagon for washout equipment.....	478*	Superheater performance, Tests of, P. R. R.....	230*
Crane, Ball bearing column.....	436*	Shop practices, Standardizing, by H. C. Spicer.....	560‡	Superheater, Schmidt, Road tests of.....	1497
Crank pins, Turning, in a quartering machine.....	475*	Shop schedule system on the Frisco.....	590*	Superheater tests, Pennsylvania.....	222‡
Crosshead shoes, Jig for drilling, B. & O.....	320*	Shops, Steel freight car repair, by E. T. Spidy.....	131*	Superheater tubes, Welding of.....	13*
Cylinder cocks, Tools for finishing, N. & W.....	432*	Side bearings, Frictionless return roller, A. C. L.....	384*	Superheater unit connection, Soft metal grinder for.....	549*
Depth gage for telltale holes, Sou. Pac.....	434*	Side bearing, roller, Creco.....	1276*	Superheaters, The discussion on.....	1454‡
Device for holding cylinders while drilling smokebox flanges.....	319*	Signal equipment, Train brake and.....	1294*	Supply Trade Notes	
Device for reclaiming journal box packing, by Alden B. Lawson.....	129*	Signal system, Electro-pneumatic, Air Brake convention.....	302	Acme Railway Equipment Co.....	337
Device for removing stand pipes, Rock Island.....	488*	Sims, Milton L., Painting locomotives and steel cars.....	641	Acme Supply Co.....	218*
Dial rims for adjusting gage hands, C. & N. W.....	92*	Sinclair, Dr. Angus, Minor mechanical organizations.....	1470	Adams, A. C.....	163
Dies for bending cellar bolts, Lehigh Valley.....	487*	Slabbing mill cutter, C. of G.....	638*	Alden, G. W.....	217
Dies for bending steam pipe flanges, P. R. R.....	482*	Slack adjuster, Gang punch and dies for forming.....	97*	Allbee, E. E.....	109
Dies for forging grab irons, Lehigh Valley.....	487*	Slide rule, Pocket.....	103*	Allen, C. W.....	55*
Dies for forging running board saddles.....	475*	Slingsby, Ernest W., Drilling the smokebox flanges of locomotive cylinders.....	319*	Allison, Wm. L.....	110*
Dies for forging the back end of back tube sheet braces, P. R. R.....	482*	Slipping, Watering the rails to prevent.....	178, 282‡	American Arch Co.....	109*, 218*
Dies for forming bosses on ash pan levers, P. R. R.....	639*	Slotter (see also Machine Tools)		American Car Roof Co.....	447
Dies for forming brake hangers, P. R. R.....	639*	Smart, G. E., Wooden cars in freight trains.....	581	American Hoist & Derrick Co.....	391
Dies for forming slack adjusters.....	97*	Smith, Leroy, Devices for shop use.....	97*	American Locomotive Co.....	555, 607, 655
Dies for forming wrenches, Lehigh Valley.....	486*	Smith, W. W., Engine house efficiency.....	407	American Steel Foundries.....	391, 447
Dies for making ashpan connecting jaws, P. R. R.....	482*	Smith shop tools, by J. F. Perritt.....	148*	Anderson, W. T.....	217
Dies for making nut lock washers, P. R. R.....	640*	Smoke, Abating, with hand firing.....	458	Anthony, J. T.....	218*
Distributing valve, E-T Combination tool for repairing, by F. W. Bentley, Jr.....	418*	Smoke chart, Ringleman.....	514	Ashton Valve Co.....	555
Door hangers, end, Tool for making, S. A. L.....	148*	Smoke prevention.....	506, 1479‡, 1482*	Association of Manufacturers of Chilled Car Wheels.....	655*
Door for oil furnaces.....	143*	Smoke prevention schemes.....	312‡	Averill, E. A.....	163*
Drawbar rivets, Tool for shearing, S. A. L.....	148*	Socket washer for grab irons.....	157*	Barnes, F. H.....	337
Drilling, Air motor for light, Sou. Pac.....	434*	Soda ash feeder for boiler feed pumps.....	74*	Barney & Smith Car Co.....	655
Eccentrics, Chuck for boring and turning, C. of G.....	379*	South African Railways, Narrow gage dining car.....	42‡	Bauer, W. F.....	163
Eccentrics, Chuck for turning.....	199*	Southern Locomotive Steam Engine Valve Gear Co., Locomotive valve gear.....	46*	Bentley, Walter.....	275
Eccentric keyway milling device.....	144*	Southern Pacific, Saving car days.....	516	Best, Leigh.....	655
Emergency wheel stand.....	380*	Southern Pacific, Special tools.....	434*	Black, G. M.....	337
Exhaust nozzle, Grinding, A. C. L.....	322*	Special devices, Manufacture of.....	557‡	Bowser & Co., S. F.....	337
Feed valve test rack, L. & N.....	202*	Specifications and tests for material, M. C. B.....	1387*	Boyd, J. C.....	217
Flue hole cutter, C. & A.....	435*	Specifications, Buying brushes on, by H. M. Baxter.....	128	Buda Company.....	607
Gages for fitting air valves, L. & N.....	258*	Speed indicators.....	74‡	Burns, Louis H.....	337
Gang punch.....	97*	Speed recorders, Boyer, Clock attachment for.....	269*	Butler, W. W.....	55*
Hinges, Tool for punching, S. A. L.....	149*	Speed recorders, T. E. A. convention.....	511	Butler Company, Ltd., W. W.....	55
Improved tool holder for wheel lathes, A. C. L.....	142*	Speedometer and recorder for passenger cars.....	1275*	C & C Electric & Manufacturing Co.....	555
Injector connections, Jig for expanding and reducing.....	198*	Spicer, H. C., Grinding exhaust nozzles.....	322*	Campbell, R. M.....	110
		Spicer, H. C., Reclaiming cast steel driving boxes.....	375*	Canadian H. W. Johns-Manville Co., Ltd.....	55
		Spicer, H. C., Standardizing shop practices.....	560‡	Carbo Steel Post Co.....	337
		Spidy, E. T., Short rivet shear.....	642*	Carnegie Steel Co.....	447
		Spidy, E. T., Standard gage tracks through shop buildings.....	4‡	Central Steel Co.....	447
				Chambers Valve Co.....	447
				Chadwick, E. M.....	110
				Chicago Car Heating Co.....	163
				Chicago-Cleveland Car Roofing Co.....	337
				Clark, Frank H.....	275*
				Coburn, R. G.....	109*
				Cole, R. C.....	275
				Collett, Robert.....	275
				Coolbaugh, F. W.....	337
				Cooper, Wm.....	108*
				Corse, Wm. M.....	391
				Contant, J. G.....	555
				Coyle, W. H.....	109*
				Crane Company.....	447



Supply Trade Notes (Continued)

Cross, C. W. 447  
 Curry, C. C. 337  
 Curtain Supply Co. 275  
 Dahlstrom Metallic Door Co. 217  
 Damascus Brake Beam Co. 108  
 Daniels Safety Device Co. 499  
 Davis, Tom R. 607  
 Dudge, Graham 499  
 Detroit Graphite Co. 110  
 Detroit Seamless Steel Tubes Co. 337  
 Detroit Twist Drill Co. 275  
 Dickinson, Inc., Paul 337  
 Dillon, E. P. 391  
 Dix, John W. 447  
 Dixon Crucible Co., Joseph 391  
 Doty, Leman D. 337  
 Doud, Willard 499  
 Duff Mfg. Co. 218  
 Durbin Train Pipe Connector Co., Ltd. 655  
 Economy Device Corporation. 163\*  
 Edgar Steel Seal & Manufacturing Co. 499  
 Edison Storage Battery Co. 163  
 Edison Storage Battery Supply Co. 163  
 Efficiency Co. 337  
 Electrolytic Gas Co., The 218  
 Equipment Improvement Co. 447  
 Falls Hollow Staybolt Co. 337  
 Fettinger, H. O. 555  
 Flannery Bolt Co. 607  
 Flint & Chester, Inc. 337  
 Franklin Railway Supply Co. 109\*  
 Galena Signal Oil Co. 607  
 Gardiner, A. T. 555  
 Garratt-Calahan Co. 447  
 Gaylord, T. P. 556\*  
 General Brake Shoe & Supply Co. 163  
 General Railway Supply Co. 275, 337  
 Gisholt Machine Co. 607  
 Green, H. W. 390, 447  
 Griffin, Thos. A. 56\*  
 Griffin Wheel Co. 55, 56\*  
 Grigg, Frank N. 217, 275, 555  
 Gold Car Heating & Lighting Co. 55  
 Gould, Charles Moulton. 607  
 Gun-crete Co., The. 555  
 Gurley & Schraeder. 217  
 Hale & Kilburn Co. 108, 163\*  
 Haring, Ellsworth 655  
 Harrington, Howard & Ash. 655  
 Harrison, C. E. 655  
 Hart, Eli F. 655  
 Hawks, E. A. 217  
 Heffelfinger, A. E. 217  
 Heine, K. A. 163  
 Hequembourg, H. C. 655  
 Hills, George 217  
 Hodgkins, E. W. 163  
 Hodgkins & Co. 217  
 Holloway, Harry C. 447  
 Humes, W. Sharon. 337  
 Hyland, Charles 607  
 Independent Pneumatic Tool Co. 607  
 Industrial Works 337  
 Ingersoll-Rand Co. 275  
 International Oxygen Co. 218  
 Jenkins, W. D. 391  
 Jerguson Manufacturing Co. 108  
 Johnson, Dudley A. 391  
 Johnson, Walter A. 275  
 Johnson, W. J. 555  
 Johnston, K. R. 108  
 Keystone Grinder & Manufacturing Co. 447  
 Kinney, J. N. 217  
 Kollock, F. N., Jr. 337  
 Kurz, C. A., Jr. 218  
 Lambert, M. B. 391  
 Lawrence Steel Casting Co. 391, 447  
 Lichtenhein, Alan 109\*  
 Lima Locomotive Corporation. 337  
 Lukens Iron & Steel Co. 655  
 Lyndon, Geo. W. 655\*  
 National Graphite Lubricator Co. 337  
 National Lock Washer Co. 337  
 National Malleable Castings Co. 108  
 Neale, John C. 447  
 Neff, J. P. 109\*  
 Neilson, Charles 391  
 Nickel Chrome Car Wheel Co. 56  
 Niles-Bement-Pond Co. 391  
 MacArthur Brothers Co. 275  
 McClellan, B. S. 110  
 McClellan Nut Co. 110  
 McConway & Torley Co. 447  
 McCoole, A. F. 55  
 McCormick, C. H. 391  
 McDonald, W. D. 337  
 McKeen Motor Car Co. 447  
 Magraw, W. E. 655  
 Manning, Maxwell & Moore. 110  
 Mason, Stephen C. 447  
 Michigan Malleable Iron Co. 337  
 Midgley, Stanley W. 218\*  
 Moler, A. L. 655  
 Monarch Steel Castings Co. 217, 337, 447  
 Mudge & Company 607  
 Muther, Ellis F. 607  
 Ohio Locomotive Crane Co. 217  
 Orenstein-Arthur Koppel Co. 108, 275  
 Overly, C. F. 275  
 Parsons, G. W. 218  
 Patterson, John Steele. 607  
 Pearce Oil Corporation. 275

Supply Trade Notes (Continued.)

Perry, Ralph W. 447  
 Pierce, C. F. 607  
 Inlud Brothers Co. 499  
 Pittsburgh Steel Products Co. 55  
 Platt, E. F. 218  
 Pomeroy, L. R. 391\*  
 Pullman Company 109  
 Purdy, Frank A. 55\*  
 O & C Company. 607  
 Railroad Valuation Co. 447  
 Railway List Company. 655  
 Railway Materials Co. 555  
 Randolph, J. L. 163\*  
 Raymond Concrete Pile Co., The. 555  
 Reading Specialty Co. 55  
 Reiche, A. 108  
 Rhoades, C. W. 499  
 Richardson Scale Co. 217  
 Rodger Ballast Car Co. 655  
 Ryerson & Son, Jos. T. 447  
 Safety Car Heating & Lighting Co. 109  
 Savage, Harlow D. 218\*, 337  
 Schlacks, C. H. 108, 163\*  
 Schraeder, Frank J., Jr. 217  
 Schurch, J. F. 108  
 Scully, Alexander B. 337  
 Scully Steel & Iron Co. 337  
 Sellers & Co., William. 337  
 Shepard, Victor J. 337  
 Shute, Henry D. 556\*  
 Siemens Wenzel Electric Welding Co. 217  
 Smith, Bertram 163  
 Smythe, J. E. 655  
 Snedaker, W. H. 55  
 Snow, Muir B. 275  
 Spamer, Richard F. 337\*  
 Standard Chemical Co. 655  
 Standard Heat & Ventilation Co. 275  
 Standard Steel Castings Co. 391  
 Standard Stoker Co. 163\*  
 Stentor Electric Mfg. Co. 337\*, 555  
 Swank, James M. 391  
 Symington Co., T. H. 217  
 Titan Storage Battery Co. 391  
 Titanium Alloy Mfg. Co. 391  
 Totten, R. C., Obituary. 56\*  
 Transportation Utilities Co. 217, 275, 337, 391  
 Union Fibre Co. 217, 275, 391  
 Union Railway Equipment Co. 391  
 U. S. Metal & Manufacturing Co. 555  
 United States Light & Heating Co. 275, 391\*, 447  
 United States Metal Products Co. 555  
 United States Steel Corporation. 275  
 Van Cleve, Spencer. 607  
 Van Dorn, T. B. 607  
 Vanderbeck, S. R. 217  
 Waddell & Harrington. 655  
 Wardwell, H. F. 217, 607  
 Watson-Stillman Co. 275\*  
 Webb, H. P. 391  
 Welding Materials Co. 217, 337  
 Weston, A. H. 217  
 Westinghouse Church Kerr & Co. 217, 218  
 Westinghouse Electric & Manufacturing Co. 108\*, 218, 337, 391, 556\*  
 Westinghouse, Henry H. 607\*  
 Westinghouse Lamp Co. 337  
 Whitcomb, F. L. 55\*  
 Whiting Foundry Equipment Co. 217  
 Willcoxson, W. G. 447  
 Williams, C. P. 337  
 Wiltonco Manufacturing Co. 108  
 Yardley, Charles B., Jr. 555  
 Sweden, Freight cars in. 50†  
 Sweringen, F. H., Repair track mileage does not pay dividends. 466

T

Tables for designing elliptic springs. 356  
 Tables for electric locomotive data. 415  
 Tank drain valve and strainer for injector suction pipes. 326\*  
 Tank hose connections, Check nut for. 377\*  
 Tank, locomotive, Removing paint from. 93  
 Tank, tender, Lehigh Valley. 72\*  
 Taps, Staybolts. 1504†  
 Taylor system, by W. W. Scott. 413  
 Tegge, Albert R., Rolling stock on curves. 357\*  
 Tender truck, Pennsylvania. 67\*  
 Tender truck, Structural steel. 542\*  
 Tenders, Coal space and adjuncts of, report at Fuel convention. 290  
 Terry, O. N., Locked grease plug. 50\*  
 Test committee report, Master Painters' Association. 527  
 Test, Comparative, of roller and plain bearings on the Bangor & Aroostook. 19\*  
 Test rack, Portable combination for E-T equipment, C. & N. W. 378\*  
 Testing machine, Derihon portable hardness. 204\*  
 Testing materials. 1383§  
 Tests, Brake efficiency, on steel and iron wheels, by F. K. Vial. 187\*  
 Tests, Laboratory and road, for locomotives, M. M. convention. 1484\*  
 Tests of refrigerator cars. 241  
 Tests of steam gages and safety valves, Interval between. 13\*  
 Tests of superheater performance, P. R. R. 230\*  
 Tests of the weathering of Pittsburgh coal. 572

Tests, Road, of Schmidt superheater and brick arch. 1497  
 Thomson, George, A remedy for draft gear troubles. 362  
 Thomson, S. G., Address at Master Boiler Makers' convention. 314  
 Throttle lever, Roller friction clutch for. 101\*  
 Ties, Railway, in New York State. 405†  
 Tilt, E. B., Some notes on chilled cast iron wheels. 470\*  
 Tinware, Standardization of. 1453§, 1463\*  
 Tire heater, Portable, Eric. 94\*  
 Tires, Depth of cut for turning. 322  
 Tires, Service of Vanadium steel. 175\*  
 Tires, Turning driving wheel, by H. M. Brown. 61†  
 Tires, Turning driving wheel, by M. Flanagan. 281\*‡  
 Tollerton, W. J., Grain tight construction for box cars. 81\*  
 Tongs for carrying large pipes. 405\*  
 Tonnage rating, Train resistance and. 1489\*  
 Tonnage rating, Train resistance and. 1489\*  
 Tool cabinet for the machine shop. 424\*  
 Tool clamp for wheel lathes, Rock Island Lines. 644\*  
 Tool Foremen's convention. 394§  
 Tool equipment for locomotives. 478\*  
 Tool room equipment and management, by Paul R. Duffey. 87\*  
 Tool room grinding, report at Tool Foremen's convention. 427  
 Tool room notes, by A. R. Davis. 638\*  
 Tools and formers, blacksmith shop. 482\*  
 Tools and machinery in use on the Frisco. 591\*  
 Tools, Economy in. 277§  
 Tools for locomotive repairs. 143\*  
 Tools, shop, Distribution of, report at Tool Foremen's convention. 431  
 Tools, Special, report at Tool Foremen's convention. 432\*  
 Tracings, Making, without ink. 494†  
 Tracks, Standard gage, through shop buildings, by E. T. Spidy. 4†  
 Trailer truck, Pennsylvania. 66\*  
 Train brake and signal equipment, M. C. B. report. 1294\*  
 Train building, Modern, Air Brake convention. 303  
 Train lighting, M. C. B. report. 1375\*  
 Train resistance and tonnage rating, M. M. convention. 1489\*  
 Training of men for engine house work, by Charles Maier. 127  
 Training of young men in railroad work, by George M. Basford. 69  
 Transportation Utilities Co., Journal cooler. 155\*  
 Traveling Engineers' Association (see also Meetings).  
 Tripoli, Italian, Railway construction in. 25†  
 Truck, Arch bar, with swing bolster. 521\*  
 Truck, Car, M. C. B. report. 1357§, 1370\*  
 Truck, Economy engine. 154\*  
 Truck, Engine and tender, Recent designs of. 539\*  
 Truck, four-wheel with clasp brake, Jersey Central steel coaches. 627\*  
 Truck frame, Pedestal jaw. 1314†  
 Truck, Leading, on the P. R. R. Mikado. 347\*  
 Truck side frame, Boltless. 1504†  
 Truck, Six-wheel, for Lehigh Valley well car. 75\*  
 Truck, Steel, with clasp brake rigging, N. Y. C. 359\*  
 Truck, tender, Structural steel. 542\*  
 Truck, trailing, Austin. 382\*  
 Truck transoms, Method of reclaiming. 198\*  
 Trucks, Steel, for passenger service. 26\*  
 Tube cleaner, Lagonda. 440\*  
 Tube sheets, Removing front, by Paul R. Duffey. 39\*  
 Tubes, Melted boiler. 399\*‡, 452†  
 Tunnels, The greatest railway. 50†  
 Turbines, steam, Increasing size of. 200†  
 Turbines, Steam, in Stockholm. 226†  
 Turner, Walter V., Development of the universal control valve. 303\*  
 Turntable, Ball bearings on. 329\*

U

Underframes, Steel, for use on wooden freight cars. 515\*  
 Unloading machines, Damage to freight car equipment by, M. C. B. report. 1387  
 Union Railway Equipment Co., Union drop brake shaft. 101\*  
 Universal control valve, Development of, by Walter V. Turner. 303\*

V

Valve gear, A few facts about, by Hal B. Stafford. 461  
 Valve, Conductor's. 301  
 Valve for roundhouse blowers, Jenkins Eros. 438\*  
 Valve gear, Southern. 46\*  
 Valve gear, The Young. 43\*, 61†  
 Valve, Pilot operated, for hydraulic presses. 440\*  
 Valve spindles, Jig for repairing. 198\*  
 Valves, cylinders, crossbeads and guides. 411  
 Valves, rotary, Jig for grinding in, on E-T equipment, C. & N. W. 42  
 Valves, slide valve feed, Repairing, L. & N. 141\*

Page numbers under 1,000 refer to Railway Age Gazette, Mechanical Edition; those over 1,000 refer to the Daily Railway Age Gazette. \* Illustrated article; § editorial; † short non-illustrated article or note; ‡ communication.

Van Housen, W. R., Strength of locomotive boilers ..... 224‡  
 Vanadium steel tires, Service of..... 175\*  
 Vanadium steel for blow pipes..... 575‡  
 Vanadium steel in locomotive construction. 1503\*  
 Vanclain, S. M., Address at Master Boiler Makers' convention ..... 313  
 Vaughan, H. H., Cast iron wheel records.. 82\*  
 Vaughan, H. H., Standard car improbable.. 25  
 Ventilating the Underground Railways..... 246‡  
 Ventilator, car, Mudge-Peerless ..... 548\*  
 Ventilator, Utility honeycomb..... 1403\*  
 Vestibule connections, European..... 557‡, 573\*  
 Vestibule curtain fixtures..... 1314\*  
 Vial, F. K., Brake efficiency tests on steel and iron wheels..... 187\*  
 Vibratory requirement for staybolt iron... 450‡  
 Victorian State Railways, Ball bearings on turntables ..... 329\*  
 Vincent, H. S., Turning effort of Lehigh Valley locomotive ..... 225‡  
 Vise, Divided machine..... 50\*  
 Vulcan Process Co., Acetylene generator... 1312\*  
 Vulcan Process Co., Malleable iron welded by oxy-acetylene ..... 546\*

W

Wade, E. H., Melted boiler tubes..... 452‡  
 Walker, Thomas H., Bracing of boiler heads 454‡  
 War, The effects of, on industry..... 640‡  
 Warner, C. W., Jig for machining eccentrics ..... 94\*  
 Warner-Reiss Sales Co., Starwal system water heater ..... 265\*  
 Water alarm, Low..... 155\*  
 Water gage, Reflex, with metal encased glass ..... 542\*  
 Water heater, Starwal system..... 265\*  
 Water stops, Reducing..... 610‡  
 Watson-Stillman Co., Emergency jack..... 647\*  
 Watson-Stillman Co., Hydraulic shaft straightener ..... 211\*  
 Weight, Excessive, in rolling stock..... 166‡  
 Welder, Portable electric..... 541\*

Welding and cutting metal with oxygen and Lintsch gas ..... 263\*  
 Welding and cutting, oxy-acetylene, report at Blacksmiths' convention ..... 485  
 Welding and cutting torches, Oxy-acetylene welding, arc, Westinghouse..... 266\*  
 Welding, Autogenous, report at General Foremen's convention ..... 324\*  
 Welding, Autogenous, in locomotive fire-hoses, by N. H. Ahnholz..... 583\*  
 Welding, Electric, Can. Pac..... 149\*  
 Welding, Oxy-acetylene and electric, Boiler Makers' convention ..... 321\*  
 Welding, Oxy-acetylene process for malleable iron ..... 314  
 Welding, Some modern methods of..... 546\*  
 Wells, Myron E., The so-called draft gear problem ..... 200  
 Wernicke-Hatcher Pump Co., Rotary air compressor ..... 365  
 West Disinfecting Co., Portable steam sterilizer ..... 597\*  
 Western Railway Club (see also Meetings).  
 Westinghouse Air Brake Co., Brake tests on Pennsylvania ..... 541\*  
 Westinghouse Electric & Manufacturing Co., Electric welding equipment..... 136\*  
 Westinghouse Electric & Manufacturing Co., Shop illumination by quartz lamps..... 324\*  
 Westinghouse Electric & Manufacturing Co., Vacuum lifting device..... 650\*  
 Westinghouse, George, Career of..... 312\*  
 Wheel design, Cast iron, for cars..... 173\*  
 Wheel lathe tools, Milling cutter for machining and resharpening..... 189  
 Wheel records, Cast iron, by H. H. Vaughan 434\*  
 Wheel shop, An efficient, M. St. P. & S. S. M., by B. N. Lewis..... 82\*  
 Wheeling & Lake Erie, Device for feeding boiler compound..... 33\*  
 Wheels, Car ..... 514\*  
 Wheels, Chrome-Vanadium steel, Service records of ..... 1286‡, 1298\*  
 Wheels, Some notes on chilled cast iron... 493\*  
 Wheels, steel and iron, Brake efficiency tests on, by F. K. Vial..... 470\*  
 187\*

Wiley & Russell Manufacturing Co., Stay-bolt taps ..... 1504‡  
 Wilkins, Oscar P., President's address, Master Painters' Association..... 527  
 Williams, J. S., Spring rigging and tire repairs ..... 374\*  
 Williams, R. G., Safety applied to grinding wheels ..... 428\*  
 Williamson, H. C., Band saw for cutting metal ..... 490\*  
 Wine Railway Appliance Co., Socket washer for grab irons..... 157\*  
 Winterrowd, W. H., Mikado type locomotive ..... 169\*  
 Wolfgang, W. H., Ball bearing column crane ..... 436\*  
 Wolfgang, W. H., Dividing the circumference of a circle..... 620  
 Wolfgang, W. H., Tongs for carrying large pipe ..... 405\*  
 Wood, Arthur J., Distribution of energy in a locomotive ..... 414  
 Wood, Arthur J., Predetermination of locomotive performance ..... 458\*  
 Wood, Charles E., What should be done with wooden underframe cars?..... 235  
 Wood & Co., R. D., Gas producer..... 437\*  
 Wood & Co., R. D., Hydraulic bushing press 494\*  
 Wood, Use of, in New York..... 342‡  
 Word of thanks, A..... 451‡  
 Work checking system on the Frisco..... 588\*  
 Workmen, Chinese as..... 204‡  
 Wrench, A novel form of..... 156\*  
 Wrench for hopper cars..... 270\*  
 Wrenches, Jig for milling, C. of G..... 638  
 Wright, J. B., Painting steel cars..... 527  
 Wright Safety Air Brake Co., Safety air brake appliance ..... 47\*

Y

Young, C. D., Tests of superheater performance ..... 230\*  
 Young, O. W., Valve gear..... 43\*, 61‡

Page numbers under 1,000 refer to *Railway Age Gazette, Mechanical Edition*; those over 1,000 refer to the *Daily Railway Age Gazette*. \* Illustrated article; ‡ editorial; † short non-illustrated article or note; ‡ communication.



# Railway Age Gazette

MECHANICAL EDITION

INCLUDING THE  
AMERICAN ENGINEER

PUBLISHED ON THE FIRST THURSDAY OF EVERY MONTH BY THE  
SIMMONS-BOARDMAN PUBLISHING COMPANY,  
WOOLWORTH BUILDING, NEW YORK, N. Y.

CHICAGO: Transportation Bldg. CLEVELAND: Citizen's Bldg.  
LONDON: Queen Anne's Chambers, Westminster.

EDWARD A. SIMMONS, *President.* L. B. SHERMAN, *Vice-President.*  
HENRY LEE, *Secretary.*

The address of the company is the address of the officers.

ROY V. WRIGHT, *Editor.*

E. A. AVERILL, *Managing Editor.* A. C. LOUDON, *Associate Editor.*  
R. E. THAYER, *Associate Editor.* GEORGE L. FOWLER, *Associate Editor.*

Subscriptions, including the eight daily editions of the *Railway Age Gazette* published in June in connection with the annual conventions of the Master Car Builders' and American Railway Master Mechanics' Associations, payable in advance and postage free:

United States, Canada and Mexico.....	\$2.00 a year
Foreign Countries (excepting daily editions)....	3.00 a year
Single Copy .....	20 cents

Entered at the Post Office at New York, N. Y., as mail matter of the second class.

WE GUARANTEE, that of this issue 4,250 copies were printed; that of those 4,250 copies, 3,747 were mailed to regular paid subscribers and 150 were provided for counter and news companies' sales; that the total copies printed this year to date were 4,250—an average of 4,250 copies a month.

VOLUME 88. JANUARY, 1914. NUMBER 1.

## CONTENTS

### EDITORIALS:

Articles on Car Work.....	1
Four Cylinder Locomotives .....	1
Roller Bearings on Coaches.....	2
Improvements in Locomotives.....	2
Locomotive Boiler Inspection .....	3

### COMMUNICATIONS:

Why Do We Incline Swing Links?.....	4
Standard Gage Tracks Through Shop Buildings.....	4

### GENERAL:

Starting Power of a Locomotive.....	5
College Men and the Railroads.....	11
Locomotive Boiler Inspection.....	13
Locomotive Design During 1913.....	15
Railway Accidents and Their Causes.....	16

### CAR DEPARTMENT:

Sand Blast for Cleaning Steel Cars.....	17
Roller Bearings on Coaches.....	19
Lunch Couter Car .....	22
Discussion of Steel Box Cars.....	23
Steel Trucks for Passenger Service.....	26
Interstate Commerce Commission and Steel Cars.....	28
Convertible Box and Stock Car.....	28

### SHOP PRACTICE:

Notes on Apprentice Instruction.....	31
An Efficient Wheel Shop.....	33
Installation and Maintenance of Electric Headlight Equipment.....	36
Removing Front Tube Sheets.....	39
Abrasive Wheels .....	40
A Plant for Reclaiming Asbestos Boiler Lagging.....	41
Jig for Grinding in Rotary Valves on E-T Equipment.....	42

### NEW DEVICES:

The Young Valve Gear.....	43
Motor Drive for Beaudry Hammers.....	44
Cross Slide Flat Turret Lathe.....	45
Southern Locomotive Valve Gear.....	46
Safety Air Brake Appliance.....	47
Geared Drill .....	48
Convertible Open Side Planer.....	48
Refrigerator Car Door Fixtures.....	49
Divided Machine Vise .....	50
Locked Grease Plug .....	50

### NEWS DEPARTMENT:

Notes .....	51
Meetings and Conventions.....	52
Personals .....	53
Supply Trade Notes.....	55
Catalogs .....	56

### Articles on Car Work

When this paper reaches your hands there will still be nearly thirty days before the close of the competition on articles relating to the work of the car department. Three weeks is not too much time to prepare a good article unless you already have the subject matter pretty well arranged in your mind. We take this opportunity of calling your attention to the nearness of the closing date—February 1—and to urge that you submit your article as soon as possible. The judges are all busy men and the articles which reach us early can be submitted to them before the closing date and thus lighten their labor and allow us to announce the winner in the March number. However, do not understand this to mean that we prefer to receive a poorly prepared article early in preference to a carefully considered one which reaches us at the closing date. We want your best efforts and are willing to pay well for them. The prize of \$50 of course, can be given to but one contestant, but if your article is suitable for publication, and is used, you will be well paid for your trouble. Remember that this competition includes articles which cover any phase of the interest or work of the whole car department. Articles on design, repair, operation, car shops, labor, etc., will be considered.

### Four Cylinder Locomotives

The Paris, Lyons & Mediterranean has recently completed a four years comparative test between two four-cylinder locomotives, one being compound and the other simple. The test was made under exactly similar conditions. Both were of the Pacific type, the compound weighing, in average working order, about 3,500 lb. less than the simple. A summary of the results shows that 16 per cent greater loads, higher speeds and more rapid acceleration have been attained by the compound. There was also a saving of 20 per cent in coal and 13 per cent in water. As a result of these tests 85 similar compound engines have been built or are under construction. The state railways of Sweden have also found similar success with compound locomotives and are re-introducing them.

It is interesting to note the readiness with which this type of engine is accepted on the other side of the water, in view of the fact that so few are used in this country. It might be said, however, that had these four-cylinder compound engines been compared with two-cylinder simple engines of the same power there might have been some difference in the results obtained, especially if the cost of maintenance was also taken into consideration. In the comparison with a four-cylinder simple engine, the complications in construction were the same for both engines, and the tests covered only the economy while the locomotives were running. The general use of four-cylinder engines on the continent, however, shows clearly the excellent conditions existing in regard to maintenance. Another factor is that the service so far as weight of trains is concerned is not as severe as it is in this country. The speed of trains, however, is greater in many cases. For these reasons the continental railways find it possible to use many of the refinements in locomotive construction that are believed to be impractical in America.

No one can make a comparison between foreign and American locomotives that will be at all satisfactory without going into great detail as to the character of the roadway, labor conditions, cost of materials and labor, and even financial considerations and the racial characteristics of the people. Even then, individual exceptions arise which require special treatment. For instance, the Santa Fe in this country is running a large number of balanced compound Pacific type locomotives. They have had long experience with the balanced compound engine and the cranked axle and show no inclination to discontinue this type. In fact the decision is to continue its use and the latest order of heavy passenger locomotives are balanced compounds.

No one can fairly claim that the service of locomotives on the Santa Fe, at the present time, is not as good or even considerably better than the average road in this country. Thus the balanced compound is a success on one typical American railway but, nevertheless, it cannot be correctly stated that it has been a success in the country as a whole. It may be some day.

We cannot afford to overlook the lessons that can be learned from closer attention to the locomotive development on foreign railways, any more than they can afford to overlook what we are doing. It is doubtful if this fact is as fully appreciated, as it should be.

**Roller  
Bearings on  
Coaches**

It is frequently necessary to put a second locomotive on a high speed passenger train entirely for the purpose of providing sufficient reserve capacity to make up the time lost by slow downs and stops from block signals or other interference, cold weather or a bad rail. All railroad men know how long it takes even the largest passenger locomotive to bring a heavy train from a stop to full speed, and when these stops or slow downs occur every few miles the time lost is a serious matter.

While by no means all of the resistance of starting a heavy passenger train is that due to the journals, the journal resistance is a continually increasing proportion of the total resistance as the speed is decreased and of course, at the instance of starting, it comprises nearly 100 per cent of the resistance. Therefore, anything which will reduce the journal friction has an immediate affect on the rate of acceleration and reduces the time lost by slowdowns and stops along the road. Furthermore, the reduced journal friction will also, of course, somewhat reduce the tractive effort required to pull the train at full speed.

Roller bearings have been running on a moderately heavy passenger coach for over three years. They have been fully successful on that car and the tests made indicate the possibility of a considerable fuel saving from a train made up of cars so equipped. This car is on the Bangor & Aroostook and the construction of the bearings and the service of the car, as well as some tests, are given in an article elsewhere in this issue. While ball bearings have not yet had the opportunity of showing their possibilities in a full size steam railroad car for this length of time, the experience with them on a very heavy all-steel coach, covering a few months indicates that a successful arrangement of journal with ball bearings can also eventually be expected. Another similar all-steel coach is fitted with roller bearings in much the same form as is used on the Bangor & Aroostook, and both of these cars are now in regular every day service.

When the reliability of this character of journal and anti-friction bearing is fully proved, there is no doubt but the advantages offered will be quickly grasped, especially by those roads which are fully equipped with block signals and are subject to frequent congestions of traffic.

**Improvements  
in  
Locomotives**

If you should ask the question, "In what way has progress been shown in locomotive design during the past year?" you would probably receive the reply, from most railroad men, to the effect that it was the extensive application of the superheater and brick arch, larger locomotives and the perfection of the mechanical stoker. Such an answer would be correct so far as it goes, but there are many other things going on in connection with locomotives which eventually may be as important in their final effect on the efficiency and capacity of the locomotive as the superheater has been.

An article in the Railway Age Gazette (December 26) reviews the recent progress and draws attention to a number of very interesting phases of the development which are not as prominent as those mentioned above.

One of these is the success that is following the use of alloy steel properly heat-treated for locomotive parts. In addition to those parts where the steel is used for its effect in giving greater reliability or improved wearing qualities, such as frames, springs, axles and tires, it is also used for other parts where, indirectly, it permits a large increase in the capacity of passenger locomotives. This result comes about from the fact that the permissible weight that can be put on drivers depends very largely on the weight of the excess counterbalance that is included to balance the reciprocating parts. Therefore, by lightening the reciprocating parts and reducing this excess it is possible and permissible to use an increased static weight on the driving wheels. This in turn means that the boiler can be very materially enlarged and thus the capacity of the locomotive will be increased.

Alloy steels, properly heat treated when combined with careful designing, will accomplish much in reducing the weight of the reciprocating parts. The Pennsylvania has shown in its latest Atlantic type locomotive what can be done in this direction. The total weight of all the reciprocating parts on one side of this locomotive, which has cylinders 23½ in. x 26 in., is but 1,000 lbs. There are probably very few Atlantic type locomotives, of even less power than this one, where the reciprocating parts on one side will be much less than 1,500 lb. The net result of the reduction is that a dead weight greater than 65,000 lb. can be placed on each axle of this locomotive with entire safety. At 70 miles an hour the dynamic augment of the excess counterbalance is less than 30 per cent of the dead weight on the drivers and the locomotive will not impose as great a strain on the track nor do as much damage to itself as most engines which have a weight of from 50,000 to 55,000 lb. on each driving axle.

This is one of the things that alloy steel has done, but it is not to be understood that the success of this locomotive is entirely the result of the use of this material. Among other features a new method of equalizing the weight has been employed which has been very influential toward the final success of the design. It seems that there is yet considerable to be learned about the equalizing of locomotives.

Proper opening for the admission of air to the ash pan has a surprising effect on the economy and capacity of the locomotive. Some people are beginning to realize their shortcomings in this direction, and many of the recent locomotives are showing the effect. You cannot get too large an air inlet to the ash pan and the opening through the grates should be as large as the quality of fuel used will permit. The design of the grates themselves has also shown considerable improvement.

Progress is also being made in the appreciation of the value of a long flamework between the bed of fuel and the admission to the tubes. This of course followed a more careful investigation as to the reason why the brick arch gave the economy it is showing. It developed that it is simply a matter of allowing sufficient time for the completion of the reaction which starts at the beginning of the distillation of the gases from the fuel but is checked immediately the gases enter the end of the tubes. It is this principle which largely accounts for the improvement that followed the introduction of the combustion chamber. Advantage is being taken of this knowledge by the more progressive roads and larger fireboxes are becoming the rule. There is no doubt but that there can be further progress made along this line, and it is probable that increased knowledge of the processes of combustion and the best construction to obtain the full value from the fuel will be the line of greatest advance during the next year.

There is another movement that has gradually taken place which has not received much comment, and that is the use on some of the more recent and best designed locomotives of comparatively large cylinders. This practice has been found advisable for use in connection with superheated steam where



it was clearly shown, by the work on the locomotive testing plant at Altoona, that for the best results in economy, the cut-off should not be later than 30 per cent. On some of the larger freight locomotives increased size of cylinders is also being used in connection with the stoker since it has been found that the steam making capacity of the boiler is decidedly increased and the larger cylinders can be used to good effect.

An increase in the effort to standardize locomotive parts and even in some cases the standardization of the whole locomotive, which is gradually becoming more general, is by no means the least important tendency of the times. Some roads have had a greater opportunity to accomplish results along these lines than have others and are now noticing the pleasing effect on their maintenance costs.

As the Railway Age Gazette article points out, valve gears are by no means being overlooked in the general improvement and considerable change toward the use of lighter parts and improved steam distribution can be expected.

It has been suggested by H. Montgomery, superintendent of motive power and rolling stock of the Rutland, that roller or ball bearings could be used to good advantage in the connections in the valve gear. The proper sizes of such bearings can be purchased and their advantage in this connection would no doubt be worth having. So far, however, no one has made such an application.

The value of the railway supply companies to the railroads and an appreciation of their work is given in this article in the following words: "Credit should be given to various railway supply companies, locomotive builders and other auxiliary activities for developing original improvements and the energy put forth in co-operation with the railway companies in bringing locomotives to the highest state of efficiency. Many of the most important and valuable appliances which are now in universal use would, beyond doubt, have languished for many years had it not been for the interest and energy of supply companies in rapidly developing them to a state of perfection. The superheater, brick arch and stoker are prominent examples. Under the present organization of the motive power departments on many railroads, there is little opportunity for initiative or experiments, and the work of the locomotive builders and supply companies has been of very great importance and value in the bringing of the American locomotive to its present position."

#### Locomotive Boiler Inspector

The attendance and interest shown in the paper presented by Frank McManamy, chief inspector of locomotive boilers, Interstate Commerce Commission, at the December meeting of the Western Railway Club, is a good indication of the efforts being made by the railways of this country to better understand the requirements of the federal boiler inspectors, and to do their best to live up to these requirements. It was suggested by one speaker that the federal boiler inspection department definitely decide on certain devices that would be acceptable to it, and to definitely state where they should be located and the manner in which they should be connected to the locomotive. But, as Mr. McManamy said, the purpose of the law is not to standardize locomotive equipment and thus hinder development, but to see that, no matter what device is applied to a locomotive, it is perfectly safe and will not in any way affect the safe operation of the locomotive. This attitude of the locomotive boiler inspection department is most admirable, broad and constructive.

From the discussion it is evident that the railroads and the federal inspectors are getting closer together than when the boiler inspection law was first put into effect. As Mr. McManamy intimated, the purpose of the commission is not to keep hitting the railroads over the head with a club, but to act more or

less as a check on the boiler work. When changes may be made for the increased safety of locomotive boilers it is the idea of the inspectors to reason out with the railroad mechanical officers wherein these items may be changed to insure safety to locomotive operation.

The results obtained during the fiscal year ending June 30, 1913, show in certain respects a marked improvement over the previous year; less trouble was experienced and there seems to be a closer relation between the boiler inspectors and the railroads. There were 21.7 per cent. more locomotives inspected, 11.8 per cent. more were found defective, and 38.4 per cent. more were held out of service than last year.

Mr. McManamy directed attention to the possibility of failure in welds of superheater tubes. Thus far only one failure of this sort which has caused injury has been reported, and investigation has shown that this was due to the flue being thinned by heating in a defective furnace. There are now over 10,000 superheater locomotives in this country, with a total of about 300,000 large flues. A very large percentage of these have been safe-ended one or more times, so that the percentage of failure thus far is extremely small, almost negligible, in fact. The superheater has come into prominence very rapidly, and in the early stages of its introduction many of the railroad shops were not equipped with the heavy machinery for safe-ending the superheater flues. Very many of the welded flues now in service were welded under power hammers with improvised dies, or in flue welding machines which were designed and constructed to handle very much smaller tubes. Now, however, the railroads are rapidly installing improved and heavier machinery designed particularly for handling the large flues, and within the next few years all of the roads will probably be well equipped to handle the large flues with the best of equipment. Undoubtedly, therefore, since the methods of handling these flues have been improving rapidly, there should be no great trouble from this source if the welding is given proper attention. The department of locomotive boiler inspection has not laid down any regulations as to the handling of these flues, and will not unless the trouble should increase to such an extent as to make it necessary for the department to interfere.

#### NEW BOOKS

*Alternating Currents and Alternating Current Machinery.* By D. C. and J. P. Jackson. Bound in cloth, illustrated, 967 pages, 5½ in. x 8¼ in. Published by the Macmillan Company, 66 Fifth avenue, New York. Price \$5.50.

Since 1896, when the book was first published, the Jacksons on alternating current has been recognized as one of the leading authorities and text books on this involved subject. Owing to the rapid progress that has been made during the past ten years in the solution of difficult problems connected with alternating current machinery and the development of new phases of many of the older problems, it has been necessary to rewrite and greatly extend the original book. The new edition maintains the well-known features of the earlier work in which were worked out the characteristics of electric currents, their self-induction, electrostatic capacity, reactance and impedance, and the solutions of alternating current flow in electric circuits in series and parallel but more attention has been given to the transient state in electric circuits than was the case in the original edition. A large amount of related matter has been introduced and the treatment of power and power factor has been given greater attention. More space and more complete treatment has also been assigned to synchronous machines and synchronous motors and generators. While this book is intended primarily as a text book for colleges and advanced schools it is also of great value as a reference work for all engineers who have to deal with alternating current.

## COMMUNICATIONS

### WHY DO WE INCLINE SWING LINKS?

Boston, Mass., November 5, 1913.

TO THE EDITOR:

As is well known, it is the custom to incline swing links downward and outward when in their normal position. The result is this: When a car approaches a curve, the outside wheels of the leading truck are raised by the elevation of the outer rail, and the swing of the links increases the torsion in the car body, overloading the springs on diagonally opposite corners. This undesirable effect raises the question of the advantages of inclining the links.

An investigation brings out statements variously worded, but in general they seem to signify that swing links are employed to cushion the shocks between the rails and the car body by allowing the center of gravity of the body to have a lateral

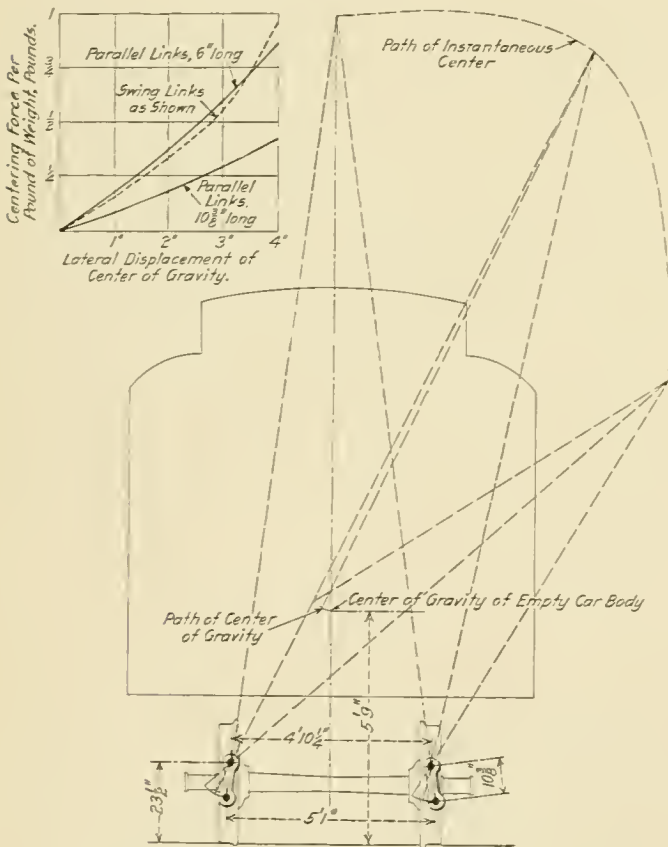

Graphical Study of the Action of Swing Links

motion, and the links are inclined to prevent, or reduce, that same lateral motion and keep the center of gravity over, or nearly over, the center of the track. If the links are so arranged that their center lines cross at the height of the center of gravity of the body, it is clear that the arrangement is just as rigid as any rigid truck could be. The ordinary incline, however, only partially neutralizes the effect of the swing. The criterion of the effectiveness of the links is the relation between the lateral displacement of the center of gravity of the body and the centering force produced by the weight. This can be controlled within practical limits by the length of the links or by the use of symmetrical three-point suspension hangers.

The accompanying diagrams were made as a study of a special case. The large one shows the path of the center of gravity of the car body as the links swing, and the smaller one shows the relation between the lateral displacement and the centering force with the car as shown, having the links of the same length but

parallel, and with parallel links six inches long. It shows that the centering tendency would be practically the same with the six-inch links, and the advantages of the inclination disappear.

In this connection it is interesting to observe that occasionally the links are inclined downward and inward, and the practice is upheld by the explanation that it allows the center of gravity to swing out more freely, throwing more weight on the outer wheels and facilitating the inevitable slipping of one of the wheels on curves.

G. E.

### STANDARD GAGE TRACKS THROUGH SHOP BUILDINGS

WINNIPEG, Man., December 12, 1913.

TO THE EDITOR:

In the article on page 648 of the December number on "Standard Gage Tracks Through Shop Buildings," Mr. Duffey says "It is a great mistake to make no provision for a standard gage track from end to end of the center section of the shop."

This does not appear right to me, as instead of the layout of a shop being made with a view to obtaining maximum production, as is universally recognized, we must change our viewpoint and lay out the shop with a view to facilities for erecting machinery. It is a great convenience to be able to unload and erect machinery with a crane, but while this may often be possible in machine and boiler shops it is seldom so in blacksmith shops on account of the many steam and smoke pipes to be accommodated. Apart from providing a track for unloading inside the shop, to place this track from end to end in the center of the shop is to place it right where the steam hammers are usually placed. Large steam hammers are seldom placed other than along the center of the building for several good reasons, one being that it allows a greater number of blacksmiths quick access to the hammer, and another that the shocks of a large hammer are much more equally distributed over the building. In reality the difference in cost of installing a large steam hammer with and without a power crane on a shop track is not worth considering. A few weeks ago we had occasion to renew part of the foundation under a 3,300-lb. steam hammer. We had no crane, so we set up a pair of shear legs, dismantled the machine and lifted it back from the foundation and then lifted the anvil block weighing 11 tons, all in two days, one day being spent in obtaining and setting up the shear legs and one day in the moving. Taking into consideration that a central track for a shop 200 ft. long would cost between \$200 and \$300 to install, and the impracticability in the case of the average shop, I am certain the balance would be on the loss instead of the profit side. With a capable millwright there is very little time lost in rigging up to lift these heavy weights, and little commotion is caused.

E. T. SPIDY,

Assistant General Foreman, Canadian Pacific.

NEW STATIONS IN GERMANY.—Within the last two years seven important new stations, representing an outlay of over \$30,000,000, have been opened on the Baden Railways system.

EXCESSIVE SPEED AND ACCIDENTS.—High speed was an important contributing cause of several serious accidents during the past year. On many roads there is no limit to the speed at which passenger trains are allowed to run. Enginemen are thus encouraged to run their trains at excessive speed in an effort to make up time lost on schedules that are in many cases already sufficiently fast for safety. Such high speed is especially dangerous in times of fog or storm, when signals can be seen but a comparatively short distance. The maximum allowable speed of trains on all roads should be established at a safe limit, and it should be left entirely to the judgment of enginemen to determine whether or not this limit is exceeded. There are devices readily available which will indicate to an engineman the speed at which his train is running.—*Interstate Commerce Commission's Annual Report.*



# STARTING POWER OF A LOCOMOTIVE

## Discussion and Explanation of a Graphical Investigation of Various Influencing Factors

BY GEO. S. CHILES

One of the peculiarities of locomotive practice, especially noticeable by those actually operating engines, is the apparent variation in the starting power of locomotives of the same design and built from the same drawings. This variation may be encountered in an order of locomotives of the same delivery; in a duplicate order of locomotives of the same identical class, also in locomotives of the same class leaving the shops after general repairs. By some this is attributed to imagination, while others assert that it is due to factors other than those inherent in the locomotive itself. As a matter of fact, the maximum tractive effort that any locomotive can exert may depend on any one or more of several variables existing in an individual locomotive. It is the purpose of this discussion to consider three of these influencing variables, which are not ordinarily mentioned in articles dealing with the design and operation of locomotives, and determine to what extent they affect the maximum tractive effort available.

These variables are as follows: The vertical offset of the cylinder center with respect to the driving wheel center; the maximum cut-off obtainable in the cylinder, and the position of the locomotive at starting.

Inasmuch as the maximum tractive effort occurs with a maximum mean effective pressure in the cylinders, and, since the latter is the result of long cut-offs which are used only at starting or at very low speeds, while the maximum demands on the boiler occur at high or sustained average speeds, the question of boiler capacity is eliminated in this connection. Furthermore, as the tractive effort depends on the adhesive weight of the locomotive, it will be assumed that the ratio of adhesion is such that the maximum tractive effort available may be utilized. In other words, that the locomotive is not over-cylindered. In considering the subject, the graphical method of solution has been selected in preference to the analytical, in order to avoid the use of complicated mathematical equations. The graphical method is easier to comprehend, and gives results sufficiently accurate for the purpose.

### THE VERTICAL OFFSET OF THE CYLINDER CENTER WITH RESPECT TO THE DRIVING AXLE CENTER.

In almost every instance the design of an American locomotive is such that the center line of the cylinders, instead of passing through the center of the main axle, is from one to four inches above it. This distance is not a constant figure, and is variably affected by the following:

First: The improper camber, or set, of the driving springs.

Second: The settling of the driving springs in service. Springs will show a decrease in camber of from  $\frac{1}{2}$  in. to  $1\frac{1}{2}$  in.

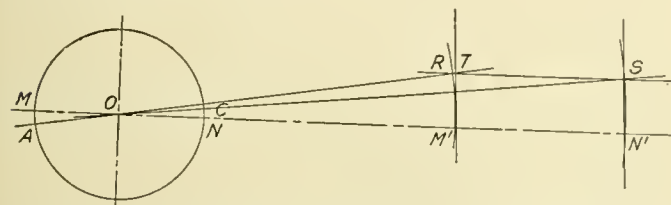

Fig. 1—Graphical Demonstration of Effect of Raising the Cylinder

after the locomotive has completed one or two round trips. This is due to the friction between the plates composing the spring. In addition, the camber of the spring may be still further decreased due to the fact that each individual plate may or may

not take a gradual permanent set. This may amount, in some instances, to from  $\frac{1}{4}$  in. to 1 in. in the course of a year.

Third: Variations in equalizers and spring hangers due to wear or improper workmanship.

Fourth: The wear of driving box brasses.

Fifth: The reduction in diameter of driving axles due to wear or turning down.

Sixth: The rolling of the locomotive. As this occurs principally at high speeds, it has little bearing on the present discussion.

Considering first the vertical offset of the cylinder center, refer to Fig. 1, which is drawn to an exaggerated scale for clearness.  $OM$  is the radius of the crank-pin;  $MM'$  (equal to  $NN'$ ) is the length of the connecting-rod, and  $M'N'$  the stroke of the piston. Assuming the center line of the piston rod to be at  $RS$ . From  $O$  as a center with  $ON'$ , the length of the connecting-rod, plus the radius of the crank as a radius, describe the arc  $N'S$  to intersect the line  $RS$  at the point  $S$ , also from  $O$  as a center with  $OM'$  as a radius describe the arc  $M'R$  to intersect  $RS$  at  $R$ . Now draw  $N'S$ , and parallel to it draw  $M'T$ . It is evident that  $TS$ , the new length of stroke, is greater than the original length  $M'N'$  by the amount  $RT$ . It may be of interest to note that the dead centers, originally at  $M$  and  $N$ , are now located at  $A$  and  $C$ , and are not on a straight line through the center of the axle. Also that the travel of the reciprocating parts is shifted slightly back toward the main axle and that the angle  $MOA$  is greater than the angle  $NOC$ . Assuming a 16-in. crank, 128-in. main rod, and 4-in. rise of cylinder center, these angles are found to be 2 degrees 3 minutes and 1 degree 36 minutes respectively.

Throughout the following analysis the forward dead center will be considered as remaining at  $N$  instead of at  $C$ . The reason for this will be explained in a subsequent paragraph dealing with the variation in guide bar pressure due to the elevation of the cylinder center.

### THE MAXIMUM CUT-OFF OBTAINABLE IN THE CYLINDER.

A specific example of steam distribution which may be taken as fairly representing American practice is the valve event diagram, Fig. 2. The data for this diagram was taken from a heavy Pacific type passenger locomotive, the values given being the average of the four readings (head and crank end of each cylinder). This diagram shows the different events and their relation to each other for different positions of the reverse lever. The average maximum cut-off was 83.3 per cent. of the stroke.

The indicator diagrams illustrated were taken from various types of locomotives at slow speeds. These locomotives were on test, and it is reasonable to assume that the steam distribution was superior to what it would be in the average locomotive cylinder.

Figs. 3 and 4 are reproduced from a paper on "The Piston Valve as Applied to Locomotives," by J. M. FitzGerald, read before the January 12, 1904, meeting of the New England Railroad Club. Fig. 4 shows the action of the steam in a hollow internal admission piston valve.

The diagrams shown in Fig. 5 were taken from a locomotive in freight service, and serve to illustrate the variations in cut-off which may be encountered in the same locomotive. In this instance, the throttle was open wide and the reverse lever was practically in full gear forward. The upper diagrams were taken at a speed of  $2\frac{1}{2}$  miles per hour (15 revolutions per minute), and the lower at a speed of 4 miles per hour (24 revolutions per minute). These diagrams are instructive in that they indicate

clearly the difference in cut-off on the right and left side of the engine.

As a further example of the actual maximum cut-off obtained in slow speed service the diagrams in Fig. 6 are taken from a

gram B was taken with the reverse lever in notch 15, although it was possible to work it as far forward as notch 20.

These cards show a wide variation in the maximum cut-off; in some instances quite a difference existing between the cut-off in the head end and crank end of the same cylinder. The average cut-off for the three diagrams taken from the consolidation locomotives, Fig. 7, varies from 72.6 per cent. to 90.4 per cent. of the stroke.

Since it is the purpose of this article to determine the effect of various cut-offs on the starting power of the locomotive, two complete indicator diagrams having cut-offs of 70 per cent. and 92

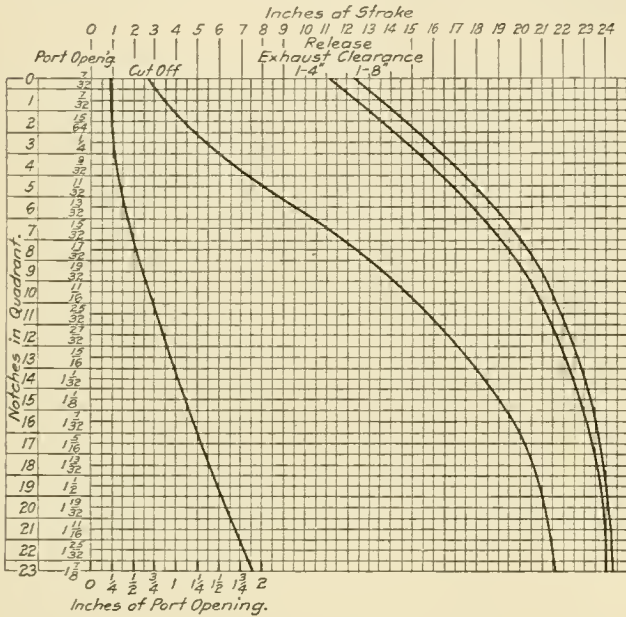

Fig. 2—Valve Event Diagram Typical of American Practice

Mallet compound locomotive operating under conditions similar to the above. In this instance the throttle was full open and the reverse lever in full gear forward; the speed being 5 miles per hour (30 revolutions per minute).

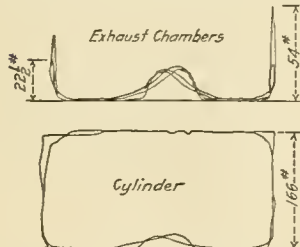

Fig. 3—Card with Solid Internal Admission Piston Valve

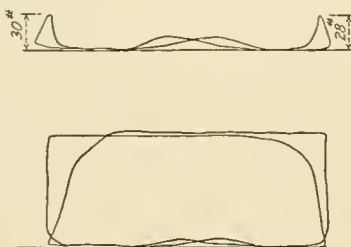

Fig. 4—Card with Hollow Internal Admission Piston Valve

The indicator diagrams A, B and C in Fig. 7 are each taken from a different consolidation locomotive, the speeds varying from 2.2 miles per hour (17.6 revolutions per minute) for dia-

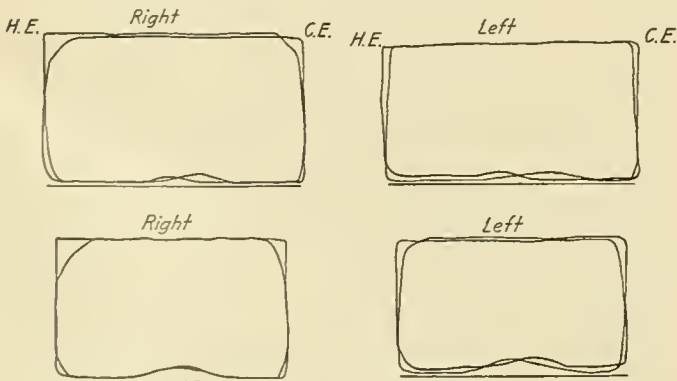

Fig. 5—Cards Showing Variation of Cut-off on Same Locomotive

gram C to 4 miles per hour (32 revolutions per minute) for diagram B. With the exception of B, the diagrams were taken with full throttle and reverse lever in full-gear forward. Dia-

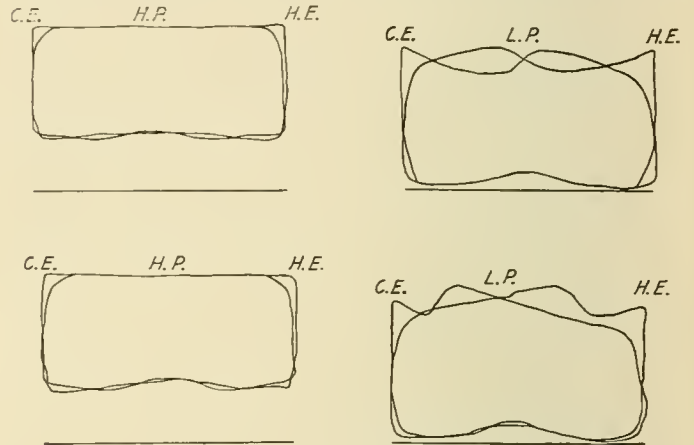

Fig. 6—Starting Cards of a Mallet

per cent. respectively have been constructed (Fig. 8). These values approximate the limiting values of the diagrams reproduced in Fig. 7, which we may assume fairly cover the range of cut-offs ordinarily obtained in starting or in slow speed service.

Accordingly, the head and crank ends of the two diagrams, Fig. 8, were constructed (the card having a 70 per cent. cut-off being superimposed upon the card having a 92 per cent. cut-off) with an equal maximum steam pressure of 184 lbs., which amounts to 92 per cent. of an assumed boiler pressure of 200 lbs. In using 184 lbs., an allowance was made for machine friction. In order to emphasize the variation in the turning force due to

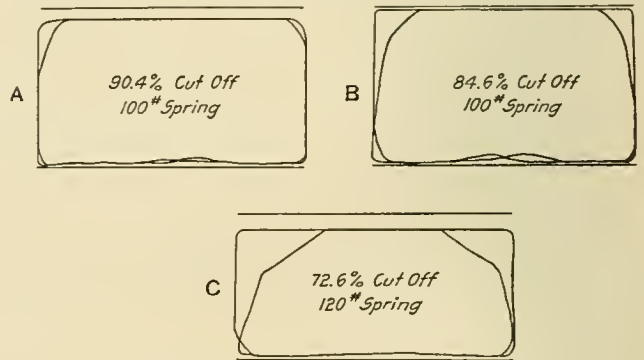

Fig. 7—Typical Cards for Slow Speed

the obliquity of the connecting-rod, the humps in the exhaust lines were removed and, in determining the force exerted on the piston by the steam in the cylinder, no deduction was made for the area of the piston rod.

Since, for a given cut-off, the diagrams are similar for each end of the cylinder, the area of the piston rod being neglected, any differences in the future analysis which might result from a variation in the force exerted by the working medium in the cylinder are eliminated, and those remaining are due solely to the mechanical principles inherent in the locomotive itself. Since the area of the piston rod has been neglected, in order to obtain



a value for the crank end of the cylinder, with which to compare with a similar value for the head end, assuming the same steam pressure in each instance, a reduction of 3 per cent. in the values of the curves for the crank end in the diagrams which are to follow is necessary.

In the lower part of Fig. 8 the full horizontal line *A-A* represents the center line of the cylinder when it intersects the center line of the driving-axle, the dotted line *C-C* representing the cylinder center raised 4 in. Starting at the right end, the position of the piston has been layed off for each 15 degrees of crank angle. It will at once be seen that the positions of the piston for the forward and back stroke will intersect on the line *A-A*, as for example when the crank is on the top and bottom quarters denoted respectively by 90 deg. and 270 deg. This, however, is not the case for the line *C-C*, the piston positions for the two strokes varying considerably as indicated by the horizontal difference between the arcs at their points of intersection with this line. The position of the piston for the different crank angles is also shown on the indicator diagrams, the full lines toward the center corresponding to the points of intersection of the arcs with the cylinder center line *A-A* and the dotted lines which are shown at the top of the diagrams corresponding to the points of intersection of the arcs with the upper cylinder center line *C-C*.

The lower diagram also shows the positions of the piston for 70 per cent. cut-off and for each successive increase in cut-off of 5 per cent. It will be noted that the cut-off lines are in two

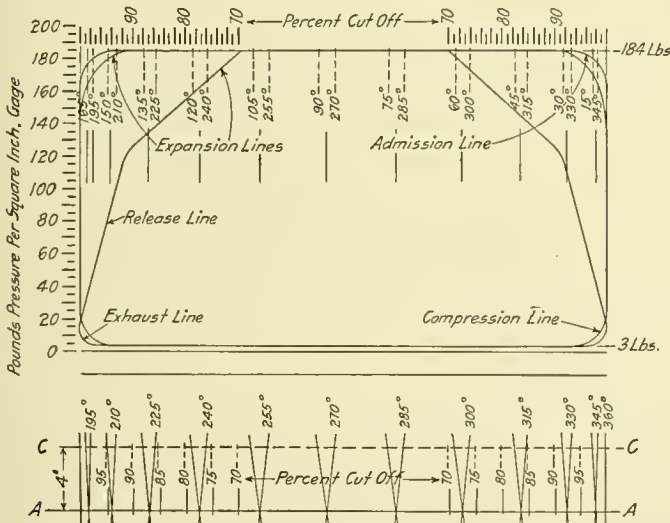

Fig. 8—Indicator Cards for 70 Per Cent. and 92 Per Cent. Cut-off

parts, one full and one dotted and that these two sections are not in line. The reason for this is because of the shift of the stroke toward the crank, due to the elevation of the cylinder center line as explained in Fig. 1, the resulting slight increase in length of the stroke being divided up equally between each end.

Figure 9 outlines the graphical method used to determine the cross-head guide pressure and the tangential force acting at the crank-pin. The former will be understood to be the pressure exerted by the cross-head on the guide due to the angularity of the main rod, and the latter is the useful component of the force transmitted through the main-rod which acts to rotate the wheels. It may be well to state that in the following graphical solution, friction was disregarded, it having been allowed for in the construction of the ideal indicator diagrams. Also that the effective steam effort is the difference between the total forces acting on the two sides of the piston. In this instance the area of the piston-rod is neglected and the effective steam effort is obtained by taking the difference between the intercepts on the

pressure line on one diagram and the exhaust line of the other diagram, as given in Fig. 8.

With the crank-pin at position *A*, Fig. 9, and direction of rotation clockwise, let  $P_1$  equal the effective steam effort transmitted through the piston-rod to the cross-head.  $C_1$  equals the thrust on the connecting-rod, and  $G_1$  equals the reaction of the guide which, if guide friction is neglected, will always act at right angles to the line of stroke. The mean steam effort  $P_1$  is the product of the area of the piston by the effective steam pressure, as noted above, taken from the ideal indicator diagrams at a point corresponding to the point *F* of the cross-head travel. Assuming a convenient scale of force, draw  $P_1$  parallel to the line of stroke  $M'N'$ , and from one end draw  $C_1$  parallel to the center line of the connecting-rod  $FA$  to intersect the perpendicular  $G_1$  dropped from the opposite extremity of  $P_1$ , the whole

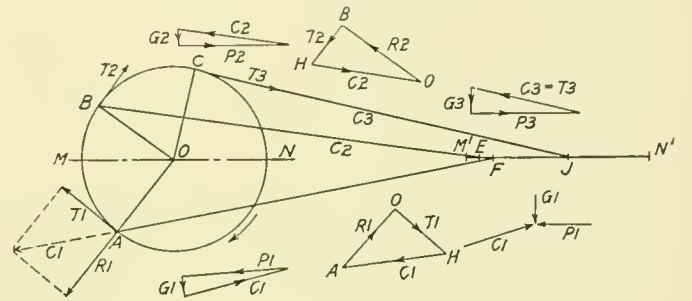

Fig. 9—Graphical Representation of the Tangential Force at the Crank Pin

forming a closed triangle of forces. Then measured to the same scale of force,  $C_1$  equals the thrust in the connecting-rod and  $G_1$  the reaction at the guides.

At the crank-pin, the thrust in the connecting rod  $C_1$  is resolved into two forces:  $R_1$  radial to the crank, and  $T_1$  tangential to the path of the crank-pin. Using the same scale of forces and a similar triangle of forces with  $C_1$  as the base line, the values  $R_1$  and  $T_1$  are found by the method just described. In a similar manner the construction is also given for the crank positions *B* and *C*, the forces  $P_2$  and  $P_3$  acting in the opposite direction due to the fact that the connecting-rod is now under tension, whereas it was under compression. At *C* the center line of the connecting-rod makes an angle of 90 deg. with the radial to the crank center *OC*, and the tangential force acting at the crank-pin is equal to the pull in the main-rod, thus giving the tangential force direct without the aid of the second force diagram. It is well understood that, neglecting the weight of the reciprocating parts, the pressure on the guide bars is due solely to the angularity of the main-rod which for forward rotation would act on the upper guide bar, resulting in a downward reaction, and for backward rotation would act on the bottom guide bar and result in an upward reaction. In this case, as we are considering forward rotation, only the reaction would be due to the upper guide bar and would act downward for all positions of the crank-pin.

Curves will now be constructed, showing how these forces vary during one complete revolution of the locomotive driving wheels. Considering first the forces acting on the guide bars, refer to the right of the locomotive and assume the zero position of the crank-pin to be to the forward dead center and the center line of the cylinder to intersect the main driving axle as shown at *A-A*, Fig. 8. As the piston will then be at the extreme forward end of its travel, and the piston-rod and connecting-rod in line, it is evident that there could be neither any tendency to rotate the driving wheels nor any vertical pressure on the guides (neglecting the weight of the parts), even with a great excess of pressure on one side of the piston. Furthermore, at starting and at very slow speeds, the energy which has to do with the acceleration and retardation of the reciprocating parts and any change in energy due to variations in speed of rotating parts



will not be appreciable and for the purpose of this discussion may be omitted. Referring to Fig. 10, curve *A-A* gives the values for the cross-head guide bar pressure throughout one forward revolution of the drivers for the case in which the center line of the cylinder intersects the center of the main driving-axle; curve *CC* for the case in which the center line of stroke is above the axle center. The points in each case are plotted for every 15 deg. of crank-pin rotation as previously used in the description of Fig. 8. The engine is assumed to be running ahead, and the crank-pin, which is at the forward dead center, is at the zero degree of revolution. Considering the curve *A-A*, as the crank-pin moves downward the pressure on the upper guide bar gradually increases and reaches a maximum value when the center line of the connecting-rod and the radial line through the crank-pin form an angle of 90 deg. which occurs, in this instance, slightly before the crank-pin reaches the bottom quarter. This assumes that the steam pressure remains constant near the center of the stroke which should be true with long cut-offs. After reaching a maximum, the pressure gradually decreases and again becomes zero at 180 deg. This cycle is repeated in the forward stroke.

It will at once be seen that the two portions of curve *A-A* are very similar, having practically the same maximum value of about 9,600 lbs. However, with the curve *C-C* such is not the case, the initial guide bar pressure instead of being zero amounts to some 2,000 lbs. The maximum pressure occurs a little earlier, and varies greatly in value, being in the one case 12,000 lbs. and

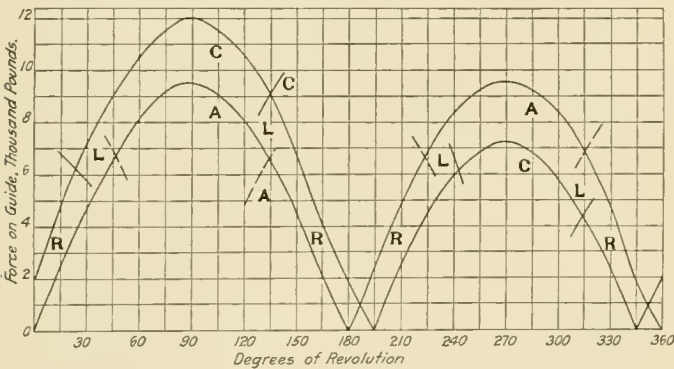

Fig. 10—Pressure on the Guides During One Revolution

7,300 lbs. in the other. Also the crank-pin instead of being at the back dead center when the guide bar pressure is zero, has moved up to 195 deg. In other words, the piston has started upon its return stroke, and when it has arrived within 15 deg. of the forward dead center the guide bar pressure again becomes zero and then increases to its approximate value of 2,000 lbs. at the end of the stroke. From this, it will be seen that, considering one side of the locomotive only, the effect resulting from the elevation of the cylinder center above the axle center is to cause the cross-head guide bar pressure instead of being similar and equal for the two strokes, to vary considerably in duration and amount, increasing some 25 per cent. on the inward stroke and decreasing by that amount on the outward stroke.

Referring now to the left side of the locomotive: The curves which would be identical are shown only where they cross the curves for the right side—this being done to avoid confusion—the broken lines corresponding to the curve *A-A* and the full lines to the curve *C-C*. To distinguish them, the letters *L* and *R* are inserted. The greatest upward pressure exerted on the right and left guides for the curve *A-A* is very uniform for the four quadrants varying between 13,200 lbs. at 135 deg. and 13,800 lbs. at 315 deg. For the curve *C-C*, however, the variation is considerably greater in the different quadrants, reaching a maximum of 18,200 lbs. at 135 deg. This amounts to an increase in upward pressure on the guides of 4,400 lbs., or about 32 per cent., due to the elevation of the center line of the cylinder a distance of 4 in. above the center line of the main driving axle.

To summarize briefly: The effect of raising the center line of the cylinder above the axle center is to vary the cross-head guide bar pressure during the inward and outward strokes and also to disturb the steam distribution. Raising the center line of the stroke diminishes the obliquity of the connecting-rod for the forward stroke, resulting in a decreased guide bar reaction, and increases the obliquity of the connecting-rod for the return stroke with a corresponding increase in guide-bar reaction. With respect to the effect of the raised cylinder center on the steam distribution, it alters the angularity of the main-rod which in turn influences the valve gear and also the turning effort on the crank pin. The higher the cylinder center above the axle center and the shorter the main-rod, the greater the variation in the steam distribution on the front and back side of the piston and the more difficult it becomes to design a valve gear that will give equal cut-offs, equal releases, and equal port-openings without sacrificing any portion of the other valve events. Eliminating the fact that a locomotive settles in service, and considering only the features included within the scope of this article, the best location of the cylinder center would be on a line intersecting the axle center. As to the main-rod, the longer it is (other things being equal), the less will be its angularity and the more even will be the turning effort on the crank-pin and the better the steam distribution.

Considering next the tangential forces acting on the crank-pin and referring to curve Fig. 11, the curve marked *RR* is seen to be similar to the one already developed and described in Fig. 10. The curves of Fig. 11 refer solely to the *AA* construction of Fig. 8, this construction being the one in which the center line of the cylinder intersects the center of the axle.

It will be noted that in Fig. 10 this curve has for its ordinates the values of the guide bar pressure in thousands of pounds, while in Fig. 11 the ordinates represent the tangential force at the crank-pin in thousands of pounds. At the right is a set of ordinates (approximately correct) having the values of the tractive effort in pounds; more will be said concerning this further on. The abscissas represent the degrees of revolution of the crank-pin or what is the same thing, the distance passed over during one complete revolution of the driving wheel, or feet of travel on the rail. Below the curve is a series of diagrams showing the positions of the right and left crank-pin for every 45 deg. of revolution; these lines connect into the abscissa line at their proper location.

Starting with the right crank-pin on the forward dead center, as shown in the diagram at the lower left-hand corner, it will be evident that the turning effort on the crank-pin will be zero. When the pin has turned through an angle of 15 deg., the turning effort will have reached a value of 21,000 lbs., as is indicated by the small circle on the curve. This value was determined as explained in Fig. 9. Similarly for 30 deg., the turning effort has reached a value of 41,500 lbs. at 90 deg., at which point the pin is on the lower quarter, the turning moment is very near its maximum value, and at 180 deg. it has again become zero, due to the fact the pin has reached the back dead center. For the remaining 180 deg., the curve is constructed in a similar manner.

From about 110 deg. to 180 deg. and from about 296 deg. to 360 deg. there are two branches to the curve *R*. The upper branch is for the 92 per cent. cut-off and the lower for the 70 per cent. cut-off, the piston being driven by the same initial steam pressure in each case as shown by the diagrams in Fig. 8. It will be evident that with the longer cut-off the mean effective pressure in the cylinder will be greater, resulting in a greater mean tangential pressure on the crank-pin. This, however, will not effect the values in the curve until after cut-off for the 70 per cent. diagram, since until this point has been reached the force on the piston is the same as shown by the diagrams in Fig. 8.

The curve marked *L* for the left cylinder is developed in a similar manner, but with one difference. Since the left main-pin follows 90 deg. behind the right pin, the two curves will vary in phase by the same amount; that is, with the right pin at its

forward dead center, resulting in a zero tangential effort, the left pin will be on its top quarter and exerting approximately its maximum tangential effort.

The effort curves for the right (R) and left (L) cylinders having been constructed, it is now possible, by superimposing one on the other, to construct a combined curve showing the total tangential effort at any point during one revolution of the driving wheels. This curve is accordingly plotted in the upper part of the diagram, and, as is the case with the lower curves, has two branches—one for the 92 per cent. cut-off, and the other for the 70 per cent. cut-off.

Referring again to the indicator diagrams, Fig. 8, it will be remembered that the maximum steam pressure was taken as 184 lbs., this being 92 per cent. of an assumed boiler pressure of 200 lbs. At 70 per cent. cut-off the mean effective pressure taken from the diagram will be 163.5 lbs., which, substituted in the

tractive effort, inasmuch as the values were figured from the mean effective pressure in the cylinders. It is well to note that the common fallacy exists in speaking of the maximum tractive effort when in reality this tractive effort is merely the average for a complete revolution. Referring to the 92 per cent. cut-off branch of the combined curve, Fig. 11, the maximum tractive effort for the quadrant A amounts to 58,800 lbs., while the average tractive effort determined from the formula for a 92 per cent. cut-off is 48,100 lbs. The difference between these values is 10,700 lbs., or approximately 22 per cent. For the same quadrant the minimum tractive effort is 38,200 lbs., or about 10,000 lbs. less than the average, and the difference between the maximum and minimum values for this quadrant is about 20,000 lbs. It will be noted that the points of maximum tractive effort for each quadrant occur with the pins on the eights and that the greatest value occurs with the pins on the forward eights, while with

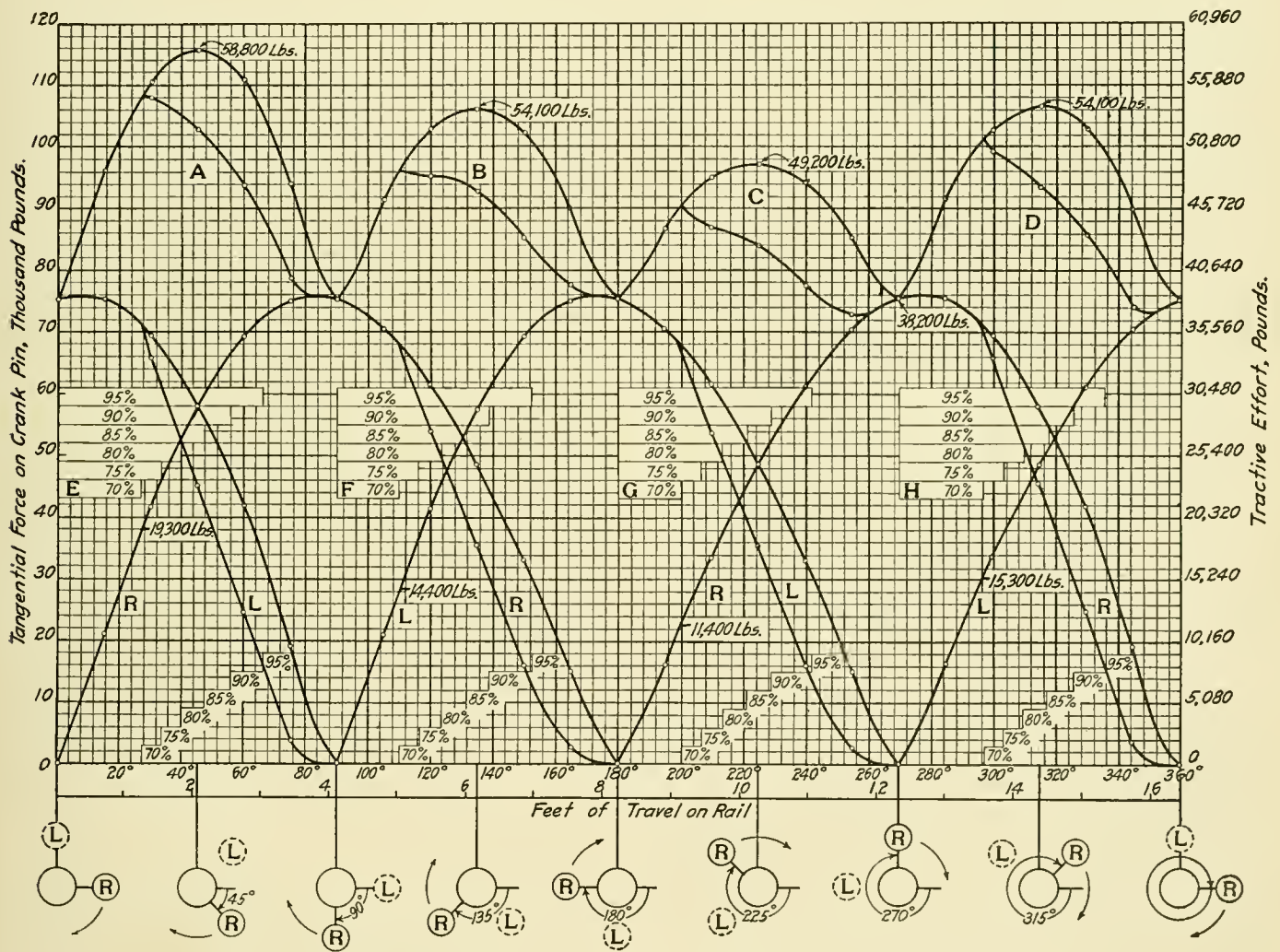

Fig. 11—Curves Giving the Tangential Force at the Crank Pin for the Full Revolution

standard tractive effort formula, gives a tractive effort of 43,950 lbs. Similarly a 92 per cent. cut-off results in a mean effective pressure of 179 lbs. and a tractive effort of 48,000 lbs. While by the customary method of assuming the mean effective pressure as 85 per cent. of the boiler pressure, the tractive effort amounts to 45,700 lbs. It will be noticed that this latter value is very nearly the mean of the other two, indicating that while the other two values were arbitrarily assumed they allow practically the same amount as the standard formula for friction, etc.

The difference between the tractive effort of 43,950 lbs. for the 70 per cent. cut-off and 48,100 lbs. for the 92 per cent. cut-off amounts to 4,150 lbs., or 9½ per cent., an increase in the average

the pins on either the upper or lower eights the values are the same. The minimum values occur with the pins on the quarters and centers and in all cases are the same.

In addition to the variation in the values of the maximum tractive efforts, the curves also indicate that there is some variation in the work performed in each quadrant. Since, like an indicator card, this diagram is plotted with the ordinates expressed in terms of force and its abscissæ as distances, its area represents work done and to obtain a measure of the work performed in each quadrant, it is simply necessary to integrate the area under each section of the curve and express it as a percentage of the whole. This was done and the following values found



for this diagram, which is constructed with the right main-pin starting from the zero position.

First quadrant (A)	.....	26½ per cent.
Second quadrant (B)	.....	25 per cent.
Third quadrant (C)	.....	23½ per cent.
Fourth quadrant (D)	.....	25 per cent.

From this it will be apparent that, not only is the maximum tractive effort greatest, but also the highest percentage of the work is done in the first quadrant; also that the amount of work done in the second and fourth quadrants is the same, as near as can be determined.

The discussion relative to the diagrams in Fig. 11 has to do only with the case in which the center line of the cylinder intersected the center line of the axle.

Taking up the case in which the cylinder center is above the axle center 4 inches and referring to Fig. 12, the full line will at once be recognized as the upper line in quadrant A of Fig. 11. This quadrant only will be considered, since the results obtained in it will indicate what is to be expected in the other three. The dotted line shows that the raising of the cylinder center shifts the curve slightly in a horizontal direction but has not the practical effect on the values of the turning force at the crank-pin and the work done in the quadrant, that it did have on the guide bar pressure as explained in connection with Fig. 10.

Having analyzed the diagrams in Figs. 11 and 12, with respect

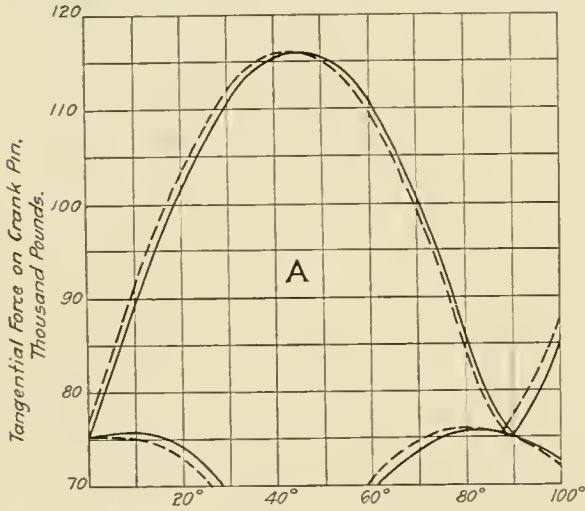

Fig. 12—Effect of Raising the Cylinder Center Line

to the variations in tractive effort and work done in the various quadrants throughout one revolution of the driving wheels at very slow speeds, and found that the average tractive effort for a 92 per cent. cut-off is about 9½ per cent. greater than that for a 70 per cent. cut-off, and that the raising of the cylinder center above the axle center has had but little effect on either the tractive effort or the work done, I will now consider to what extent the cut-off will influence the tractive effort the locomotive is capable of exerting at starting.

THE POSITION OF THE LOCOMOTIVE AT STARTING.

It will be readily perceived that when starting the valves may be so located that steam will be admitted to but one cylinder and that this condition will continue to exist until either the engine has been reversed or until part of a revolution of the drivers at least has been completed. This, in the estimation of the writer, is one of the features of locomotive design hitherto but little considered, but of great importance in meeting the present demands of heavy passenger service, and, in this connection, it is apparent that the three or four cylinder cranked-axle engine having cranks set at 90 deg. or 120 deg. may be so designed as to exert a greater starting effort than the ordinary two cylinder simple locomotive of equal adhesive weight. This will be better understood by referring to the diagram Fig. 11, starting with the zero point of the right cylinder curve in the

lower left-hand corner. Steam will be admitted until the point of cut-off has been reached, which event in the case of the 70 per cent. cut-off takes place at about 110 deg. of revolution, and which will be recognized as the intersection of the two branches of the curve R just above the end of the blank space F. During this period, steam will also be admitted to the left cylinder until cut-off occurs, represented by the length of the blank space E, and also from the period of admission in the left cylinder until cut-off occurs in the right cylinder as indicated by the end of blank space F. The spaces G and H are similar for the other half of the revolution. The spaces E, F, G and H represent the period in one revolution during which steam is being admitted to both cylinders. The ratio of the total length of these spaces to the total length of the diagram indicates the percentage of time during one revolution that both cylinders will be taking steam, which in this instance is about 25 per cent. Inasmuch as we have considered a complete revolution, starting with the right main-pin on the forward dead center and continuing in a clockwise direction until that point has again been reached, it is evident that we have included every possible starting position of the locomotive. The practical lesson to be learned from the above lies in the fact that with a 70 per cent. cut-off the chances are one in four that both cylinders will be working steam at starting. This condition is improved somewhat by increasing the cut-off to 75 per cent., and still more so by an increase to 80 per cent., and practically overcome by an increase to 95 per cent., in which latter case the chances of working steam in both cylinders at starting are as 11 to 15.

This feature, while it is of importance in its effect on the starting power of a locomotive at rest, is of little consequence once it is in motion, since with the long cut-offs the steam confined in the cylinders after cut-off, due to the short period of expansion, does not undergo any serious drop in pressure.

As a practical application of this, we will examine to what degree the starting power of the locomotive under consideration will be affected in case but one cylinder is available for starting, which might easily be the case had one valve passed the cut-off position. This is aptly illustrated by the tractive value of 11,400 lbs., which is the maximum that the locomotive can exert when cutting off at 70 per cent. shortly after the beginning of the third quadrant, even though the locomotive is rated as being capable of exerting a tractive effort of 45,700 lbs. This results from the fact that at this particular instant the valve is so located that the left cylinder is closed to steam and the right cylinder only is serviceable. Had the engine been cutting off at 75 per cent., this value would have been 14,900 lbs.; at 80 per cent., 18,000 lbs.; at 85 per cent., 22,900 lbs.; at 90 per cent., 26,400 lbs., and at 95 per cent., 31,500 lbs., all of which values can be read directly from the curves by means of a scale of tractive efforts at the right of the diagram.

As an example of how "taking the slack," as we ordinarily say, overcomes this difficulty, it is apparent when we consider that should we change the position of the valves by reversing the engine, so that both cylinders would be open to steam, the tractive effort would then be the sum of both the right and left curves and would be increased from 11,400 lbs. to 45,720 lbs. This explains why, in many instances, locomotive engineers find it necessary to reverse the locomotive "take the slack" even when starting light trains with heavy locomotives and also why it is impossible in many instances to move a light locomotive until it has attained a considerable boiler pressure.

This condition can be remedied to a certain extent by exercising care in the design of the valve-gear and by proper attention at the shops and terminals. But by far the best remedy for this condition lies in the substitution of three or more cylinders.

INJURIES TO RAILWAY EMPLOYEES.—During the fiscal year ended June 30, 1913, 195 employees were killed and 3,361 employees were injured while coupling and uncoupling cars.

# COLLEGE MEN AND THE RAILROADS

## Interesting Views and Experiences Contained In Further Communications on This Subject

A number of letters on the subject of College Men and the Railroads were published in the Railway Age Gazette, Mechanical Edition, in the November and December, 1913, issues. These were written in reply to a communication on this subject which was published on page 523 of the October issue. Several others of the more important contributions that have been received follow:

FROM A COLLEGE GRADUATE WITH CONSIDERABLE RAILWAY EXPERIENCE  
WHO HAS FOUND IT ADVISABLE TO ENTER THE SUPPLY BUSINESS

I heartily agree with the substance of the letter appearing in your October issue entitled, "Why Don't Railroads Hold the College Men," and being intimately acquainted with one of the 90 per cent. who have left the railroad service for reasons differing in part from those set forth therein, perhaps the following will also be of interest.

Both in college and during vacations I made an effort to secure a general engineering education, as basic and broad as possible. On leaving college, a position of machinist helper was obtained in a western railroad shop, and in order of sequence, advancement to clerk, draftsman, construction boss, chief draftsman, and before the termination of three years the hoped for goal of supervising all technical work in the mechanical department was reached.

The scope of the work was large; the experience splendid. I have never regretted the years so spent. The discipline received and the knowledge gained of the operation of a large transportation system were alone invaluable. The wealth of information required of those holding responsible mechanical positions, the administrative ability expected and the untiring efforts exacted were eye-openers—not at first fully comprehensible to one who had heretofore been a student of other forms of industrial activity, but—

What ridiculous appropriations! What miserable salaries! Department efficiency was hampered in every branch. Important work in view accumulated to astounding proportions, and even that part labeled "rush" became cob-webbed with age. Good assistants were almost impossible to obtain at the prices offered, and only that portion who were fascinated by the ever moving wheels and life-like energy of transportation, or were tied by wives and families, remained.

So after examining with a microscope my monthly stipend, and carefully weighing all chances for better or worse I made a change.

Perhaps I should have been content to linger until my superiors experienced a change of view on the importance of the work done by the mechanical staff, or perhaps, more likely still, until the road attained that state of perfection, which appears so simple in legislative circles, when the lucre will flow from present rates like water. But there was another reason—the chief clerk to the superintendent—one of those mysterious and most wonderful creatures who dispose of 50 per cent. of the departmental work (whether they understand it or not) and assume 400 per cent. of the authority. For further information, I would refer to articles on the Hine system of organization wherein "chief clerk rule" is one of the evils abolished.

In my opinion these constitute sufficient grounds for terminating one's connection anywhere. But before closing I cannot refrain from criticizing your editorial relating to this subject and from offering a smile on the altar of the goddess of high salaries who is ever watchful over good mechanical men between

the ages of thirty and thirty-five who have been faithful to our railroads. It would indeed be instructive if a summary of such mortals was available with properly compiled data showing length of service, present positions, remunerations, etc. It would give a good idea of the opportunities in this large and important field of endeavor. I fear that many of those who have been there and still have vivid dreams of cinders, grease, leaky flues, broken staybolts, engines in turntable pits and cars down embankments, are sadly in need of enlightenment.

FROM A CONSULTING ENGINEER, C. J. MORRISON

Referring to the communication in the October issue entitled "Why Don't Railroads Hold the College Man?" I believe the trouble is largely with the railroad organization. While there may be a great difference in the training which a college man receives in the shops on the various railroads, it is very noticeable that many of the men who have completed this preliminary course leave the railroads. This is largely for the reason that there is so little chance of advancement in the mechanical department. The railroads are so organized that a man very seldom rises from the mechanical department to the highest executive positions. This limitation means that a man must limit his ambition to the position of superintendent of motive power. This, on most railroads, is a comparatively poorly paid position which involves great responsibility and considerable hardship. Men in comparatively unimportant positions in commercial life receive higher salaries than many of the superintendents of motive power and have much easier working and living conditions.

To illustrate the situation, consider a few men who completed their preliminary course with the railroads and see what became of them. All of them graduated from well known universities at about the same time quite a number of years ago.

Two brothers graduated, three years apart, and both entered the service of the same railroad as special apprentices. The elder completed his course, held several minor positions and is today master mechanic at a small, unimportant point where living is a hardship. The younger brother, upon completion of his apprenticeship, was placed in the shop at a rate of pay a little lower than that of the ordinary machinist. He remonstrated and was told that he was not worth full pay as considerable of his time during apprenticeship had been spent on tests, inspection of material, etc., and therefore he was not a full-fledged machinist. He immediately quit, entered commercial life and is today earning more than twice as much as his elder brother. It is interesting in this connection to note that practically everyone considered the elder a more capable man.

A third man who was an apprentice on this same railroad, at about the same time, finally rose to master mechanic and is now superintendent of motive power of a small unimportant road where he has long hours, a great deal of responsibility and a very meager salary.

Still another man on the same road, at about the same time, finished his course and rose to position of assistant superintendent of motive power on another and larger road. From a railroad standpoint this was a splendid position, but as his ambition was not satisfied he left the road, entered a railway supply manufacturing business and is today president of his company.

A fifth college graduate on the same road finished his apprenticeship, and then went to another road where he is now engineer of tests at a salary of \$225 a month.

As a final illustration consider another engineer who fought



the battle all the way through, going by successive steps through his apprenticeship through the positions of foreman, general foreman, superintendent of shops, until he reached the highest position which he could hope for in the mechanical department for many years. About this time a reorganization was made and an entirely new grand division was created. This division was placed in charge of a vice-president of the road who was to have two assistants. This vice-president was a friend of the engineer in question, and he was urged to appoint this man as one of his assistants. He was shown quite conclusively the advantages of having, as an assistant, a man thoroughly acquainted with all motive power problems, but he was afraid to break over the railroad precedent and appointed both of his assistants from the operating department. As this college graduate could not break through the railroad organization with the combined efforts of friendship and ability, and rise beyond the confines of the mechanical department, he left railroading and entered commercial life. Much to his surprise he was able to double his salary almost immediately, and to triple it inside of the year. Today he has ceased to work for a salary and is conducting his own business.

It would thus seem little wonder that college graduates should leave the railroads. In fact it is surprising that any should remain, when all who are capable can do much better outside. The railroads will not be able to hold these men until they break down the barriers and make it possible for men to rise from the mechanical department to the highest positions on the railroads. There are other disadvantages of the present railroad organization which I will not take the space to mention now.

FROM DEXTER S. KIMBALL, PROFESSOR OF MACHINE DESIGN AT SIBLEY COLLEGE, CORNELL UNIVERSITY, WHO HAS FOLLOWED THE CAREERS OF MANY COLLEGE MEN

The letter by I. I. W. and the editorial comments in the October issue interested me greatly because, taken together, they present the most difficult phase of vocational education. It is now very generally recognized that a certain part of vocational training can best be given in organized schools apart from industry, while it is also recognized that such schools have definite limitations so that their work must be supplemented after the boy or girl has entered industry, if the best results are to be obtained. Just where the dividing line between school and shop shall be drawn is at present not clear, though a solution in the near future seems probable.

It is now almost universally admitted that school training is almost essential to success in callings where scientific knowledge forms the background of the industry, and it is becoming more evident every day that, other things being equal, the man with a trained mind will outstrip the man who lacks academic training, *provided proper provision is made to adapt him to the industry which he enters.*

Employers for the most part have not fully grasped the importance of organized educational methods, not only in the case of the semi-trained man under discussion, but as regards the training of men of all kinds. In most shops today reliance is placed on the old methods which depended entirely on the initiative of the workmen. Under such methods it formerly required seven years for a boy to learn a trade which we know now could have been imparted to him in two or three years if teaching methods were pursued instead of the old methods whereby he obtained his knowledge and skill by methods of absorption. Employers and employees will do well to read the articles by Mr. Gantt\* on this subject. Whatever may be the defects of so called scientific management, the theory of its advocates that it pays to teach men good methods is sound and in strict accord with all human experience. The employer who takes a college trained man into his employ and turns him loose in the shop, trusting to Providence that he may develop into a strong executive or designer, is not following out the plan that he would use to insure the education of his own

children in the ordinary branches of learning. Systematic educational methods are essential to develop the fit as quickly as possible and to find the unfit at the earliest possible moment. This does not mean that the college trained man should not work. He should work and work hard; but he should work progressively; for if he is any good he will not be content unless he is making progress. The general tendency among employers that have had experience in this line is to make the period of adaptation as short and as progressive as possible, and the conclusions of I. I. W. on this point are undoubtedly correct.

Now it is evident that, as you point out, the more the college can do the less the shop will be required to supply. It is now universally admitted that only a small part of the practical experience which a successful executor or designer must possess can be acquired in college, and consequently the greater part must be obtained in practice after graduation. There is, however, as the editor's remarks imply, a certain amount of practical application of fundamental theory that can perhaps be imparted equally well either in college or in practice. The more of this practical application of fundamental theory is given in college the less need be given in the industry.

But, again, there are limitations to the amount of such application that the college can intelligently perform. When industry was simpler it was possible to arrange a course so that all students could get some applied work in nearly all of the important branches, which were then comparatively few. But the industrial field has broadened tremendously in the last twenty years. In the field of electrical engineering alone it is not now possible to carry applied theory beyond very general types and this difficulty grows apace in all fields, thus requiring a vast staff of specialists and equipment, if the school is to keep up with modern progress, and so costly as to be most usually beyond its financial resources. This problem is also rendered more difficult by the constant changes in industry. A field that is important today is of much less or of no importance tomorrow. The turbine greatly affected the steam engine field, the gas engine may considerably affect both, and the flying machine may change the manufacture of automobiles and ships.

On the other hand, it is an exceptional student who knows exactly what he wants to do as a life work, or who knows just what he is best fitted for. Nothing but a trial will, in general, decide this question. Care must be exercised therefore that men are not specially fitted for callings that are about to change or disappear, or specialized so closely that they cannot be adapted to some other callings in case of a change. In the lower grades of industrial education where preparation for the trades is the objective point this is one of the greatest difficulties in the way of the solution of the problem, and one that is going to have a profound effect on our public school methods of industrial education. It is no less important in the preparation of college-trained men.

It is because of these conditions that I believe that the trend of all vocational education is more and more toward the teaching of fundamentals and their application to general rather than to special fields, leaving a large part of the actual adaptation to the industry itself. The distance to which any school may go in providing special preparation for specific industries will, in my opinion, be largely a local one just as pure trade schools will be justified or not depending on the volume of business in the locality concerned. It may be very desirable to have special railway schools in some localities, special schools of aviation in another and schools of naval architecture in another. But, in general, I believe that the technical school of the future will concern itself largely with fundamentals, and the employer will make more careful preparation for adapting technical graduates so as to get best results from them in minimum time. The point of view held by I. I. W. is, therefore, timely and is worthy of careful consideration.

\*See Work, Wages and Profits, by H. L. Gantt.

# LOCOMOTIVE BOILER INSPECTION\*

## The Welding of Boiler Tubes; Interval Between the Tests of Steam Gages and Safety Valves

BY FRANK McMANAMY

Chief Inspector, Locomotive Boilers, Interstate Commerce Commission

The accident records show that during the year ended June 30, 1913, there was a reduction of over 60 per cent. in the number killed and 10 per cent. in the number injured by failures of locomotive boilers and their appurtenances, in comparison with the preceding fiscal year, or with any previous year of which a reasonably authentic record exists. The practice of conducting a rigid, searching investigation of all accidents to locomotive boilers and their appurtenances sufficiently serious to justify a report, with the sole object in view of determining the exact

caused by improper application or neglect, one showed evidence of both; three were reported to have been defective, and only one showed a clear rupture without evidence of improper application, neglect or defect in the tube. This proves conclusively that with proper attention 80 per cent. of these accidents could have been positively prevented. It will, no doubt, be urged that the increase in the number of locomotives in service which are equipped with arch tubes, may account for the increased number of accidents, but as it has been shown that four out of every five arch tube failures result from improper application or neglect, they can not properly be charged to the increased number of tubes in service.

Tightening washout plugs under pressure is a practice which has caused numerous accidents, and a peculiar fact in connection with it is that in a majority of such cases this work was being done with the boiler foreman or roundhouse foreman present, and either directing or performing the work. This class of accidents is positively preventable, and strict instructions should be issued and enforced never to put a wrench on a plug while there is pressure on the boiler.

Another type of accidents which has shown an increase during the past fiscal year is injector steam pipe failures. During the year ended June 30, 1912, there were 31 accidents of this type which caused injury, in which 38 persons were injured. During the year ended June 30, 1913, there were 36 accidents of this type which caused injury, in which 47 persons were in-



Result of a Boiler Explosion Caused by Defective Crown Bar Braces

cause and having the proper remedy applied, has done much to reduce the list of casualties, and has directed attention to conditions which previously have been overlooked or ignored.

The following comparison of some of the most serious, as well as some of the most frequent accidents during the first and last quarters of the fiscal year ended June 30, 1913, fairly represents the benefits which result from government supervision over the condition of locomotive boilers and their appurtenances:

	First Quarter			Last Quarter		
	Acci- dents.	Killed.	In- jured.	Acci- dents.	Killed.	In- jured.
Crown sheet failures.....	18	10	30	9	2	13
Flue failures.....	15	..	18	11	1	11
Injector steam pipe failures	10	..	13	5	..	6
Arch tube failures.....	5	..	5	5	..	7
Water glasses bursting....	36	..	36	16	..	16
Lubricator glasses bursting	11	..	11	6	..	6

It will thus be seen that for the six classes of accidents referred to above which resulted in injury, 95 occurred during the first quarter and 51 during the last quarter. A better illustration perhaps of the improvement which has been brought about is that during the three months ended September 30, 1912, there were 95 accidents of the classes mentioned above, with 10 persons killed and 113 injured thereby, while during the six months ended September 30, 1913, there were 94 accidents with eight killed and 103 injured thereby.

A brief digest of some of the more serious accidents shows a very decided improvement on the whole, but there are certain classes of accidents where, instead of an improvement, conditions appear to have grown worse. One illustration of this is the arch tube failures. During the year ended June 30, 1912, there were 18 arch tube failures which caused injury, with none killed and 23 persons injured thereby, and during the year ended June 30, 1913, there were 20 arch tube failures which caused injury, with three killed and 27 injured thereby.

Investigation shows that of these 20 arch tube failures, 15 were



Superheater Tube Which Collapsed from the Effects of Improper Treatment in Welding

injured. In 24 cases the failure occurred where the collar was brazed on to the pipe and was due either to defective brazing or to the fact that the pipe or the collar was too thin at this point. This is a defective condition which could not readily be discovered by inspection, but the fact that such failures invariably occurred at the same point should have led to an investigation that would have disclosed the cause. In order that this condition may be properly remedied at its source, we have directed the attention of injector manufacturers and locomotive

\*Abstract of paper presented before the Western Railway Club, December 16, 1913.



builders to this weak point, and they are at the present time earnestly striving through the efforts of a joint committee with which we are co-operating to have adopted a connection that will remedy the trouble.

Another class of accidents in which there has not been an improvement is flue failures. During the year ended June 30, 1912, there were 56 failures which caused injury, resulting in one killed and 62 injured, and during the year ended June 30, 1913, there were 54 failures which caused injury, resulting in one killed and 63 injured. More attention should be given to the welding, fewer welds should be made, particularly on flues for high pressure, more attention should be given to properly testing welded tubes, and a positive limit should be fixed for scrapping.

The question of flue failures, although important of itself, has been mentioned principally because it leads up to what to me appears to be a more important question that should at once be given serious consideration by the mechanical departments of the various railroads, and by the department of the government with which I am connected, and, that question is, shall superheater tubes be welded? To the men on locomotives, the collapse or failure of one of these large tubes amounts to about the same as a crown sheet failure, because in either case, death or serious injury is almost certain. Therefore, if we are to have the same number of failures of superheater tubes due to welding that we now have with the smaller tubes, the injuries resulting therefrom will on account of the size of the tubes doubtless be so much more serious that in the interest of safety, action will have to be taken possibly even to the extent of prohibiting welds in such large tubes.

I am not making a positive statement that welds in superheater tubes will be prohibited, but that it is a matter which is being closely watched, and what action may be necessary will depend on future developments, because a large percentage of such tubes now in service are comparatively new and have never been safe ended. Many shops where this work is being done are poorly equipped for handling it, adequate tests of welded tubes are in many instances not being made, and, as might be expected, there is a wide divergency of opinion as to the best method of doing such work. That the strength of a weld is practically an unknown quantity has been demonstrated times without number, and, for this reason it is the generally recognized practice that where the highest degree of efficiency and reliability is required, welds are prohibited.

A short time ago the question was brought up by some of the railroads as to whether they would be required to remove superheater tubes once in three years in accordance with rule 10 which provides that "All flues of boilers in service, except as otherwise provided, shall be removed at least once every three years and a thorough examination shall be made of the entire interior of the boiler." It was urged that their superheater tubes should be exempt from that requirement on account of being welded in and also because their boilers could be entered, thoroughly cleaned and inspected as required by the rule, without removing the superheater tubes. To remove, so far as possible, the occasion for welding safe ends on these tubes, as well as for the reasons advanced by them, it was decided that: "Unless further investigation should prove that it is necessary to do so, superheater tubes need not be removed every three years, provided the tubes are in good condition and the boiler can be thoroughly cleaned and inspected without their removal."

Another question of considerable importance which has recently been decided, relates to the removal of brick work in oil-burning locomotives, for the purpose of hammer testing staybolts. When this question was taken up by some of the carriers, they were advised as follows:

"If staybolts which are behind brick work on oil-burning locomotives, or behind grate bearers, have a telltale hole  $\frac{3}{16}$  in. in diameter through their entire length which is kept open at all

times, the removal of the brick work or grate bearers each month for the purpose of hammer testing such bolts will not be required. This will not, however, relieve from making a thorough inspection each time the brick work is removed, nor will it relieve from removing the brick work for an inspection when necessary."

There still appear to be some requirements of the rules which are not fully understood, or, at any rate, are not properly complied with, to which I desire to direct your attention: One is that simply hammer testing staybolts does not by any means constitute a complete monthly inspection in accordance with the rules. Neither does the fact that a man has hammer tested the staybolts of itself place him in possession of all the necessary information to enable him to properly certify to the inspection report, yet we find many instances where the man who tested the staybolts certifies to the report when he has gone to some other point before the other work shown on the report was done, and as a matter of fact he does not know that it was ever done. Every item that is shown on the monthly inspection report is a part of the inspection and must be performed in accordance with the rules; washing the boiler, cleaning gage cocks and water glass cocks, testing and repairing injectors, repairing steam leaks, and inspecting arch or water bar tubes, which can only be properly done when the boiler is washed, are just as much a part of the monthly inspection as testing the staybolts and should be performed at the time the monthly inspection is made, and the man

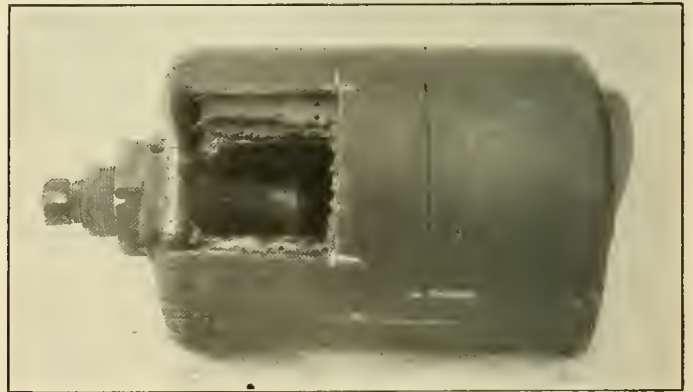

Casing of a Safety Valve Which Caused an Explosion. Pipe Wrench Marks Show on the Adjusting Screw, Which Is Screwed In Too Far

or men who certify to the inspection report must have knowledge that such work has been performed.

There also appears to be some doubt in regard to the proper construction of rules 30 and 36, relative to the interval between steam gage and safety valve tests. This period is assumed by some to be anywhere between 90 and 120 days. This is a mistake. In order that there should be a certain degree of flexibility in the rules, they were made to read that this work should be done at least once every three months, which means approximately 90 days. The proper time to test steam gages and set safety valves is each third inspection, and it should be done at the time the inspection is made so that it may be properly certified to on the inspection report. If the monthly inspections are made at the required periods, they will automatically take care of the interval between the quarterly inspections.

Another matter that has not always received the consideration that it should is the location of the bottom water glass fitting. The opening to the boiler for this fitting should always be above the highest point of the crown sheet. The necessity of carefully checking the location of water glasses and gage cocks was forcefully demonstrated a short time ago when one of our inspectors found ten new Mikados which had just been received from the builders and placed in service with the lowest reading of the water glass just below the highest point of the crown sheet.

As a means of reducing the number of plugs to be removed when boilers are washed, the practice of blanking washout openings appears to be meeting with considerable favor on some roads. I believe the statement that more boiler failures are due to poor washing than to any other one cause can be demonstrated, and that there is no other way in which the mechanical department of any railroad can lay up so much future trouble for itself at such a small saving as by slighting the washing of boilers. The matter of blanking washout openings will be watched as closely as possible, and when sheets begin to show indications of distress vigorous action will be taken.

A summary of the inspection work performed by the Division of Locomotive Boiler Inspection during the year ended June 30, 1913, discloses the following:

Number of locomotives inspected.....	90,346
Number found defective.....	54,522
Number ordered out of service.....	4,676

The number of locomotives found defective does not indicate that these locomotives were found to be in violation of the law, but they were found to contain defects which should be remedied before the locomotives were again placed in service. The number found in direct violation of the law is represented by the number ordered out of service in accordance with Sec. 6 of the law, which requires the district inspectors to issue a written order holding the locomotive for repairs when one is found that does not meet the requirements of the law or rules. No formal appeal from the action of any district inspector has been filed during the year. This, in view of the vast amount of work performed and the number of locomotives on which repairs were ordered, shows that while the inspectors have been diligent, they have also used discretion and good judgment in the enforcement of the law. It is believed that it also shows the existence of a spirit of co-operation and an earnest effort to comply with the requirements of the law on the part of a large majority of railroad officers.

DISCUSSION

The interest taken in this paper was manifested by the manner in which it was discussed. All important points brought out were well received by the members present. Some roads seem to still find trouble in obtaining a suitable apparatus for squirting cold water, although the Lake Shore is using a device that seems entirely satisfactory. The steam pipe connection to the injector was also carefully considered and thoroughly discussed. The members of the club were told that a committee of injector manufacturers and railway mechanical men met with William Dalton, chief engineer of the American Locomotive Company, last June and were carefully considering this question. The report of their findings will probably be presented before the Master Mechanics' Association next June. The trouble seems to be mainly due to improper brazing at the injector, and a lack of bends in the steam pipe to allow for expansion and contraction. It is necessary that this connection be carefully watched, as the results from a failure are almost always very disastrous.

The question of safe-ending superheater flues was also considered. The Chicago, Burlington & Quincy is welding the safe ends on these flues by the oxy-acetylene process and reports very good results. Many members expressed the opinion that under the water conditions in and around Chicago the superheater flues would not last more than one or two years, while others contended that those flues welded into the rear tube sheet and kept in a clean condition would last three years or more. The Lake Shore reported over 200,000 miles for superheater tubes which were provided with copper ferrules beaded over and welded in the tube sheet. That road is also safe-ending these tubes with the Bradley hammer with success.

All were unanimously of the opinion that it was most hazardous to tighten up washout plugs while the boiler was under pressure, and undoubtedly greater precautions will be taken to see that this is never done.

Concerning the maintenance of arch tubes, it was clearly brought out that extreme care must be exerted in keeping them clean. One road adopts the method of scrapping them, according to their weight, which seemed to meet with the approval of Mr. McManamy, providing the scrapping weight was conservative and that strict adherence was made to the standard. The Lake Shore rolls the arch tubes into the boiler heads and cleans them with a turbine cleaner at every boiler washing.

In closing Mr. McManamy, in replying to a remark that 2 in. tubes had been welded successfully so many years that there should be no reason for not welding the 5½ in. flues as successfully, said it was the desire of the department of boiler inspection that these large flues be welded decidedly better than the 2 in. flues, for a failure of one of the large flues would be much more disastrous than the failure of the small tube, and the records show that there are a number of small tubes failing. He also intimated that the future rulings or decisions as to whether any weld should be used in superheater flues will be largely governed by the way in which they act within the next few years. As the application of superheaters to locomotives in large numbers has taken place only during the past few years there has not been much necessity for safe-ending these large tubes, and one only has been brought to the attention of the commission. He stated that while a weld as a safe proposition was rather questionable, the burning of the metal either side of the weld seemed to cause the greatest number of failures. He clearly pointed out that the steam gage and safety valve tests should be made at every third inspection, which means every 90 days, and that these tests should be made during the time of the monthly boiler inspection.

LOCOMOTIVE DESIGN DURING 1913

The past year has brought important but not spectacular developments in locomotive progress. There has been much concentration on more effective use of fuel through fuel saving devices and capacity increasing factors and a marked tendency toward maximum power per unit of weight has developed. The important and helpful tendency toward co-operation on the part of engineers of the supply interests should be recognized and is being encouraged.

In a general way, the progress can be indicated and the present situation demonstrated by the following:

(1) Locomotives of the largest size for the different classes of service continue to be built almost exclusively. A beginning has been made toward applying the most economical arrangements and proportions to the lighter locomotives.

(2) Boiler capacity per pound of metal in the boiler has been decidedly increased by the use of larger fireboxes and combustion chambers, thus giving time for the completion of the gas reactions before the flues are reached. Shorter flues, giving a higher rate of evaporation per unit of area, are the result in some cases. Flues, however, in no case, are shortened from the front end and, having the size of firebox and combustion chamber desired, the flues are made as long as the weight limits will permit.

(3) Cylinders are increasing in relative size due to the lower steam consumption at shorter cut-offs when using superheated steam. Stokers are also causing enlarged cylinders because of the increase in the maximum boiler capacity.

(4) Heavier weights are being placed on drivers in connection with the lighter weights of reciprocating parts.

(5) Superheaters and brick arches are almost universally applied to new locomotives and are also being installed on many older designs.

(6) Standardization of the parts most frequently requiring repairs and the use of these parts on new locomotives as far as possible, is being more widely practiced.

In these days of diminishing and disappearing net earnings, higher average train loads must be handled. Locomotives are now being called on for results which but a few years ago would



have seemed absolutely impossible. The locomotive designers are meeting the demand and are producing Atlantic type locomotives which do as much work and haul as large trains as the Pacific type did two years ago; consolidations which perform the service that demanded Mikados in 1911, and all classes which will pull from 10 per cent. to 30 per cent. larger trains on the same amount of coal used two or three years ago. At the same time, if allowance is made for increases in wages and the increased cost of material, the cost of repairs per unit of work has been actually decreased.

The general use of the superheater and brick arch is largely responsible for this improvement, but the adjusting of all parts to the best relationship, one with the other, has been effective in continuing the improvement.

In general the problem has been to obtain the greatest drawbar pull at the highest practical speed for the service with the least total weight of locomotive. Sustained drawbar pull depends mostly on boiler capacity, and in this direction great strides are being made. While the ratio of output in steam to the weight of the boiler is increasing, still the total weight of the boiler also continues to increase. This, in turn, means greater weight on the wheels, most of it coming on the drivers. In high or moderate speed service the permissible dead weight on drivers is controlled by the hammer blow of the excess weight in the counterbalance which is controlled by the weight of the reciprocating parts. The weight of these parts is dependent on the amount of power delivered by the cylinders, and thus the cycle is complete.

While there has not actually been built this year a locomotive which exceeds in total weight the 2-10-10-2 type built by the Santa Fe in 1911, which weighs 616,000 lb., or the Virginian 2-8-8-2 type built by the American Locomotive Company in 1912, which weighs 540,000 lb., still the average weight of new locomotives built continues to increase. Selecting ten typical examples of the 2-8-2 type built during the year, the average total weight is 293,020 lb. The average for ten Pacific type engines is 273,130 lb., and for four typical consolidations the average weight is 246,875 lb.—*Railway Age Gazette*.

## RAILWAY ACCIDENTS AND THEIR CAUSES

During the year ending June 30, 1913, a total of 76 train accidents were investigated by the Interstate Commerce Commission. These accidents comprised 51 collisions and 25 derailments, and caused the death of 283 persons and the injury of 1,880 persons. The collisions investigated were responsible for 221 deaths and 1,174 injuries, and the derailments caused 62 deaths and 706 injuries.

The commission again is compelled to note the exceedingly large proportion of train accidents due to dereliction of duty on the part of employees. Fifty-six of the accidents investigated during the year, or nearly 74 per cent. of the whole number, were directly caused by mistakes of employees. These mistakes were of the same nature as those noted by the commission in its last annual report, namely, disregard of fixed signals; improper flagging; failure to obey train orders; improper checking of train register; misunderstanding of orders; occupying main track on time of superior train; block operator allowed train to enter occupied block; dispatcher gave lap order or used improper form of order; operator made mistake in copying order; switch left open in face of approaching train; excessive speed; failure to identify train that was met.

These errors are exactly the ones which figure in the causes of train accidents year after year. Their persistence, leading always to the same harrowing results, points inevitably to the truth of one or the other of the following

alternatives: Either a great majority of these deplorable railroad disasters are unavoidable or there exists a widespread lack of intelligent and well-directed effort to minimize the mistakes of employees in the operation of trains. It is not believed that all those accidents which are caused by the mistakes of employees are unavoidable. It is quite true that man is prone to error, and as long as absolute reliance is placed upon the human element in the operation of trains accidents are bound to occur, but until it can be shown that all reasonable and proper measures have been taken for its prevention no accident can be classed as unavoidable.

All of the mistakes noted above are violations of simple rules, which should have been easily understood by men of sufficient intelligence to be entrusted with the operation of trains. The evidence is that in the main the rules are understood, but they are habitually violated by employees who are charged with responsibility for the safe movement of trains. The evidence also is that in many cases operating officers are cognizant of this habitual disregard of rules and no proper steps are taken to correct the evil. Many operating officers seem to proceed upon the theory that their responsibility ends with the promulgation of rules, apparently overlooking the fact that no matter how inherently good a rule may be, it is of no force unless it is obeyed. On very many railroads there is little or no system of inspection or supervision of the work of train-service employees so far as pertains to those matters which vitally affect safety. Employees are not examined on the operating rules except at the time of their promotion, and only the most perfunctory efforts are made to determine their fitness to perform the duties assigned to them from time to time.

This lack of supervision and inspection with respect to matters affecting the safety of trains is unexplainable when the careful supervision of all matters directly affecting the revenue of the roads is considered. The auditing and checking systems used for detecting the dishonesty of employees are marvels of ingenuity and careful attention to detail, but means of determining whether trains are operated in accordance with the requirements of safety and in conformity with the rules are almost entirely lacking. Road foremen are employed to supervise the work of enginemen and to instruct them in their duties, but such supervision and instruction pertain mainly to matters affecting the proper working of engines so as to economize in the use of fuel, oil and other supplies; instruction on the rules is either entirely neglected or made secondary to matters of economy. Instruction in the use of the air brake is quite general, but this, again, is mainly for the purpose of improving practice in the direction of economy by eliminating shocks and break-in-tuos in the handling of trains, thus reducing the money loss caused by damaged equipment and lading. The prevention of accidents by a strict observance of operating rules means not only the saving of human life, but of large sums of money as well. It would seem, therefore, that adequate inspection and supervision of the work of employees to insure safety in operation would be amply justified from the standpoint of economy alone.

In previous reports the commission has recommended legislation requiring the standardization of operating rules. It is vital to the safe movement of trains that rules should be explicit and uniform in character, so that they may be easily understood and that there may be no doubt as to their application. To this end Federal legislation is necessary. Such legislation also should require proper supervision of employees, to insure that the rules are obeyed, as well as systematic instruction and examinations at stated intervals to make certain that no employee is permitted to be in a responsible position unless he is thoroughly familiar with his duties and competent to perform them.—*Annual Report of the Interstate Commerce Commission*.

# CAR DEPARTMENT

## SAND BLAST FOR CLEANING STEEL CARS

BY J. M. BETTON\*

With the rapid increase in the number of steel cars it became necessary to provide means for removing the old paint from their surfaces, as well as to prepare them for a new covering. The sand blast is generally admitted to be the most efficient and economical means of accomplishing this, and special structures are needed as adjuncts to the railroad shops to enable this work to be done continuously and without interference with other work. The two arrangements shown in the illustrations were prepared to meet the demand for a separate sand blast cleaning shop.

Each shop is 106 ft. x 38 ft. inside and 25 ft. 6 in. in height, giving ample room for sand blasting an 80 ft. steel passenger

this at the floor level is a line of standard gage track. On each side of the central track is a grating, preferably of wrought iron bars  $1\frac{1}{2}$  in. x  $\frac{1}{2}$  in. with  $\frac{5}{8}$  in. spaces, extending from end to end and supported by concrete piers, two lines of which also support the central track. Along each side of the building is a line of 24 in. gage industrial track, the ties set in the concrete flooring, each line carrying two or more flat cars upon which sand blasts are mounted. There are four 36 in. x 36 in. Drucklieb injector sand blasts, each of 2,000 lbs. capacity and weighing when filled about 2,900 lbs. Each of these is mounted on a four-wheel flat car of two tons capacity with a wooden top, cast steel wheels and roller bearings. Each sand blast is provided with 10 ft. of  $1\frac{1}{4}$  in. rubber air hose with couplings, two 25-ft. lengths of  $1\frac{1}{2}$  in. delivery hose, nozzle holders, 100 steel nozzles, two sand blasters'

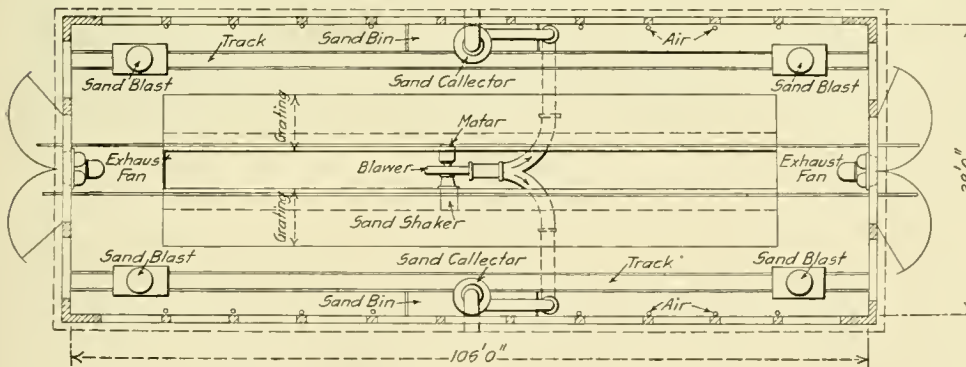
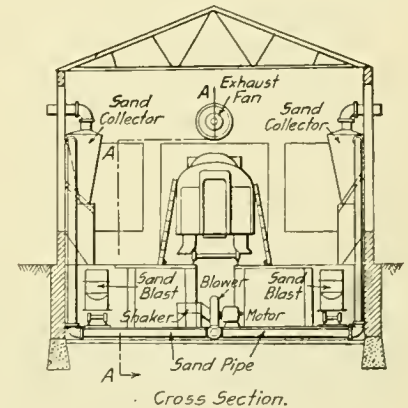
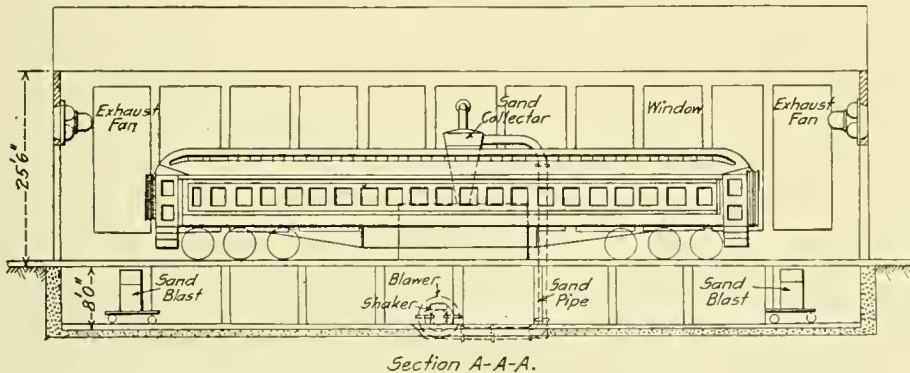

Arrangement of Building and Equipment for Cleaning Steel Cars by Means of a Sand Blast

coach or two 40 ft. steel box or gondola cars placed on a track extending through the building. The building may be built of stone, brick, concrete, or with a steel frame covered with corrugated iron. The sides and ends are well provided with windows, giving ample light, which is very essential to obtaining the best results both in quality of work and time. These windows are screened on the inside with No. 10 window netting to stop the fine flying gravel.

The cleaning shop should be located to leeward of the paint shop with respect to the average prevailing winds, to obviate any trouble from the distribution of fine dust, and at such a distance as to permit of the cleaned car passing to the point of painting as quickly as possible.

One of the illustrations shows a pit 8 ft. in the clear with concrete floor extending under the whole building, and over

helmets and the necessary connections for a single line of hose. Connection with the air piping is made at convenient points along the side walls. Each sand blast may be operated through one or two nozzles, as required, enabling four or eight men to work at the same time.

The nozzle men work from the grating at the level of the track and reach the upper parts of the cars by means of light ladders, running on an angle iron secured to the grating. The bottom of the car may be reached from the pit below.

The sand falls through the grating to the floor of the pit, upon which it is collected by means of wide hand scrapers or scoops, such as are used by street cleaners, and brought to the sand shaker, into which it is shoveled. The good sand is held on the shaker and delivered to the blower, which carries it up to the sand collector. It then falls through the collector to the sand bins, and is spouted into the sand blasts

\*26 Park Place, New York.



as required. The upper screen of the shaker holds back scale, stones, etc., and the dust and fine sand of no value fall to the ground and are removed as they accumulate.

A No. 7 Buffalo blower is used, with 14 in. inlet, and should provide 5 oz. pressure at 1,800 r. p. m. It is run by a 10 h. p., d. c. 230 volt electric motor.

There are two 14 in. Buffalo sand collectors, with 14 in. outlet leading outside of the building to discharge any dust entrained with the sand. The diameter of the shell is 56 in. and the length 96 in. Two sand bins of riveted steel, No. 16 gage, are provided, each 17 ft. long, 3 ft. 0 in. wide, 4 ft. 0 in. deep at the rear and 8 ft. 6 in. deep in front, with three 4 in. sand gates. These are supported by the walls and from below. The capacity of each bin is 17 tons. The breeches pipe connecting the two lines of piping to the blower is provided with gates, enabling either side to be used at will. This piping is laid below the floor level to avoid the sand blast tracks. The blower acts as an auxiliary dust exhaust.

where there is a tee and a vertical drop pipe with a cap and 1 in. drain cock to catch any water condensed in the piping. There are risers from this pipe between each window, fitted with a 1¼ in. straightway cock and a quick attaching hose coupling. Additional storage bins for wet or dry sand may be arranged as convenient in the pit.

The sand blasts work under 30 lbs. air pressure per square inch with ½ in. nozzles, requiring 1,288 cu. ft. of free air per minute. The air compressor may be of any type capable of delivering 1,300 cu. ft. of free air per minute continuously under an even pressure of 30 lbs. per square inch. It should be of about 130 h. p., and may be driven by steam or belt; it should never be located in the sand blast shop.

The air receiver should be of ample capacity to insure a steady and even flow of air. The sand used should be good hard, sharp, bank or beach sand or gravel, about No. 8 mesh (⅛ in. square) and must be thoroughly dried before using. It can be used a number of times before becoming too fine

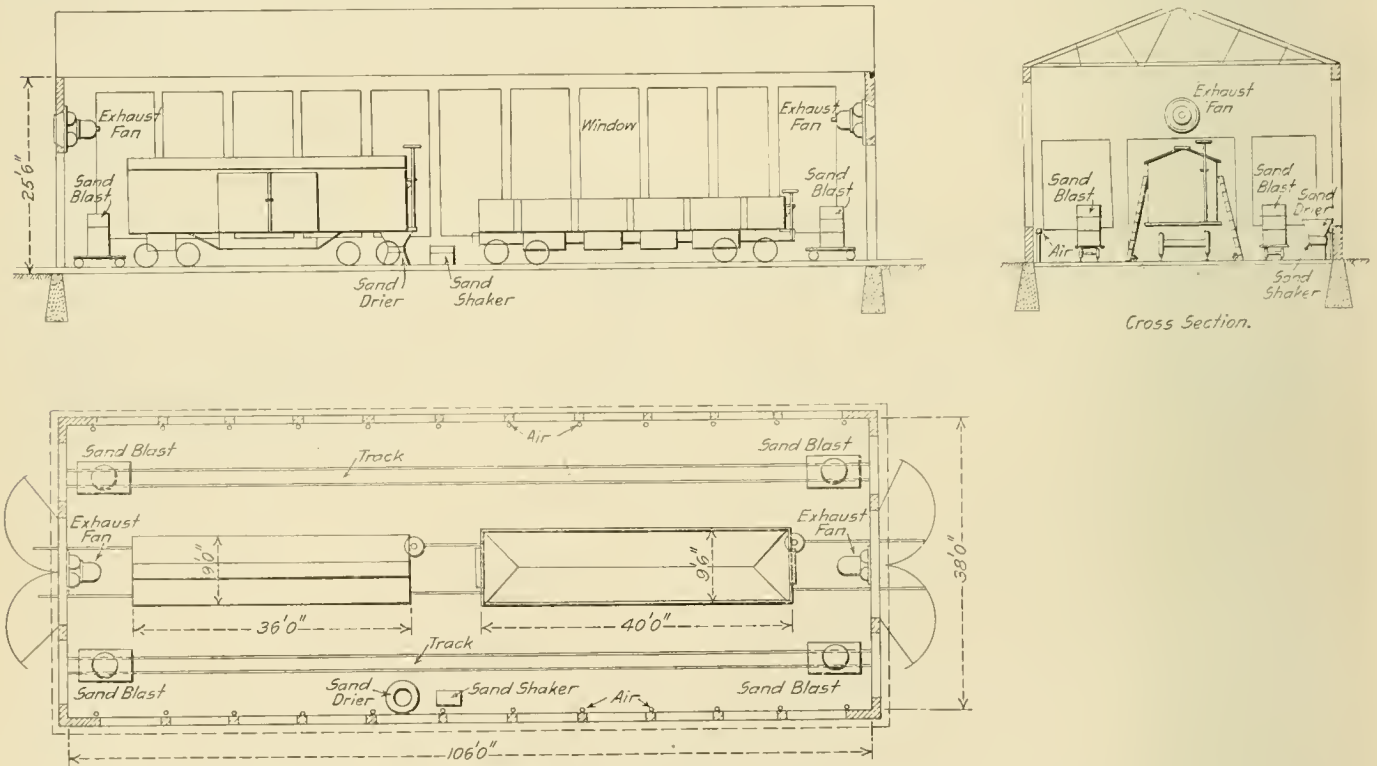

A Simpler Arrangement of Sand Blasting Equipment Which Omits the Pit and Sand Handling Apparatus

There are located at each end of the shop above the doors, a 48 in. Buffalo disc exhaust fan, operated by a d. c. electric motor. Each fan has a capacity of 18,000 cu. ft. of air per minute. The cubic contents of the building shown are approximately 150,000 cu. ft. and these two fans will change the air about every four minutes. By closing the doors and opening a window on each side in the middle of the building, currents of air will be established from the center to each end, drawing off the dust suspended in the air. With open doors and windows, and no objection arising from adjacent shops, the shop can be ventilated without exhaust fans.

A sand shaker provided with two sieves and operated by either electric motor or compressed air is included. The upper sieve is No. 8 mesh, and is provided with handles with which it may be removed to throw out stones, scale, old paint, etc. The lower sieve is No. 30 mesh and delivers the good sand through a suitable trough to the blower. The sand drier is located in the pit at any convenient point. The drier should have a capacity to dry 10 tons of sand per day.

A 4 in. air main is laid along each side of the building below the windows. It drains from each end to the center,

for effective work. The consumption of sand will be about one ton per hour.

The arrangement shown is designed for operation by one foreman, eight nozzle men and two sand men, for drying and screening the sand and refilling sand blasts, a total of 11 men.

This provides a simple and effective outfit for the quick and thorough cleaning of any steel cars. The dimensions of the building may be slightly altered and the arrangement of the apparatus changed, but it will be found that too much room has not been allowed and that the central arrangement of the sand handling apparatus will give the best working facilities. If additional capacity is needed, an arrangement of cleaning tracks, either parallel or radiating, as in a round-house, will be found preferable to extending a single track, owing to the better facilities for ventilation.

The other illustration shows a similar arrangement along more simple lines, the principal difference being in the omission of the pit and the sand handling apparatus. It is estimated that the necessary labor for operating this shop would include one foreman, eight nozzle men and three sand men, a total of 12 men when working at full capacity.

# ROLLER BEARINGS ON COACHES

## Standard 70 ft. Coaches and Interurban Cars Show Reduced Resistance and Low Maintenance Cost

It is not infrequently necessary to put a second locomotive on a heavy passenger train for the purpose of supplying extra power for starting and during acceleration, both for station stops and for the probable block signal stops or slow downs. Many late trains have been caused by the time lost in slow acceleration following an unusual number of stops or slow downs from signal or other causes. Tests that have been made in the past indicate that journal friction becomes a continually more important factor of the total resistance as the speed is decreased, and the wish has many times been expressed that it might be possible to apply anti-friction bearings to heavy passenger cars and thus allow the normal reserve capacity of a locomotive of suitable size to maintain the schedule under ordinary conditions, to take care of the unexpected slow downs. In addition the reduced resistance of the train at any speed would be an assistance to the same end. Until a comparatively recent time such a construction has not seemed feasible. The continual pressure on those studying the problem, caused by the increased weight and carrying capacity of automobiles, aided by the development of heat treatment of metals and the improved material that can now be obtained, has brought roller bearings to a

of speeds up to 65 miles an hour. During the first two years' service this car ran 175,000 miles and required absolutely no attention to the bearings except lubrication. These bearings are still in service and are in as satisfactory operating condition as when installed nearly eight years ago.

On the basis of the experience with these equipments, the design was further improved and refined, and in July, 1910, roller bearings were applied to a 25-ton interurban car operated by the Lehigh Valley Transit Company between Philadelphia and Allentown, Pa. Since that time other similar cars on that line have been equipped and sixteen cars with roller bearings are now in regular service. Six of the heavy, Pullman type cars are on high speed schedules and make an average of about 6,000 miles per car per month and are now running about 85,000 miles on three pints of oil. Experience with this equipment indicates that inspection once in 15,000 to 20,000 miles will be sufficient. The cars weigh about 80,000 lbs. without passengers.

Some similar cars on the Philadelphia & Western Electric Line have been subject to a comparative test between the roller bearing cars and those having plain bearings. These tests showed a power consumption of 6.2 kilowatt hours per car mile



Passenger Coach on the Bangor & Aroostook, Equipped with a Full Set of Roller Bearings

degree of perfection that makes them a possibility for general application to freight and passenger cars. As proof of this, an example of a 74 ft. coach with a seating capacity of 84 and a weight of 91,200 lbs. which has been in regular service on the Bangor & Aroostook for nearly two years, can be cited. During this time no faults of any kind have developed in connection with the bearing and the riding qualities of the car have been materially improved. It has been found that this car starts more smoothly, coasts more freely, stops easier, accelerates faster, and racks the car and truck less than does the plain bearing. In addition the oiling and maintenance costs have been materially reduced.

Before making an application to a full sized standard steam railroad coach, a long series of experiments were made on lighter rolling stock. In August, 1902, the Standard Roller Bearing Company of Philadelphia applied roller bearing journals under a single truck street car operated by the Syracuse Rapid Transit Company. This car was, of course, very light, but it ran for six years without repair or replacement so far as the bearings were concerned. During this time it made a mileage of over 250,000 miles. During the same period other cars of the same type, operated on plain bearings, had their bearings renewed ten times at a total cost of \$20 per wheel. In February, 1906, the same company made an application of roller bearings to a Strang gas-electric car. This car has a weight of 80,000 lbs., and is capable

for the plain bearing cars and 5.2 kilowatt hours per car mile for the roller bearing cars, a saving of approximately 17 per cent. A test was also made of the flange wear in the two cases and a checking of the shape of the wheel tread and flange by taking plaster of paris impressions after 30,000 miles in both cases, indicated that the roller bearing equipment reduced the amount of flange wear. Casts which will be made at the end of the next 30,000 miles service will probably give more positive results on this feature.

Annular ball bearings have been very successful on light weight equipment, and at the present time there are 49 storage battery streets cars provided with ball bearings in service in New York City. Applications have also been made by the Hess-Bright Manufacturing Company, Philadelphia, Pa., to a number of heavy interurban cars. The first one was made in 1908 on a 40-ton electric car on the Atlantic City and Shore Railroad. This equipment is still operating satisfactorily, and there is every reason to believe that it will continue to do so for several years. Following that application, others were made, and all have given satisfactory results, although ball bearings have not, as yet been adopted as standard by any electric railway company, save for battery car operation.

The method of application of ball bearings is the same in all cases, namely, that two ball bearings, each a complete unit, are used in each box, one inside the pedestal jaw, and one outside.



A typical construction is shown in one of the illustrations.

This rather extensive experience with heavy electric cars has developed no feature of disadvantage which would seem to prevent their use on heavier steam railroad equipment. In addition to the original car on the Bangor & Aroostook, two more of the same class have recently been fitted with roller bearings, but these three were, up to a recent date, the only steam railroad

with the results shown on the accompanying curves. Stops were made at each station in both directions. It will be seen that the basis of the test was the amount of coal consumed

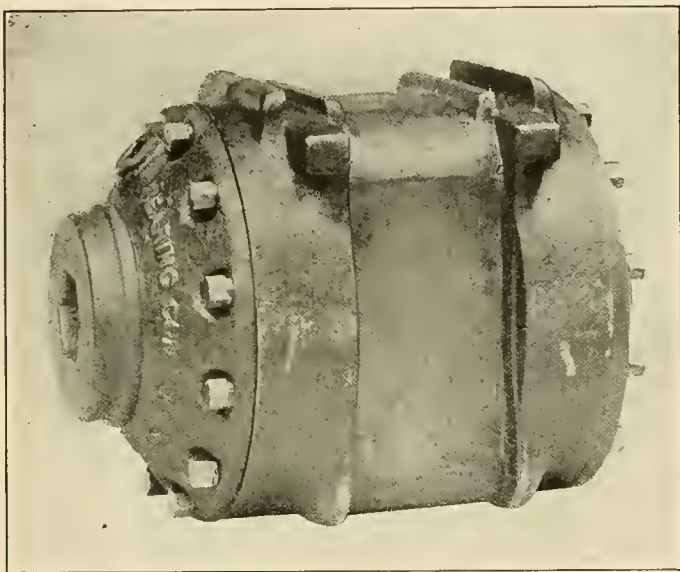

Roller Bearing Journal Box

cars that have been so equipped. During the past few months, a very heavy all-steel passenger car has been fitted with roller bearings, and another similar car with ball bearings. The experience with these cars will go a long way to determine the future application of these bearings.

A test was recently made between two trains on the Bangor & Aroostook, each consisting of a locomotive, a baggage car and

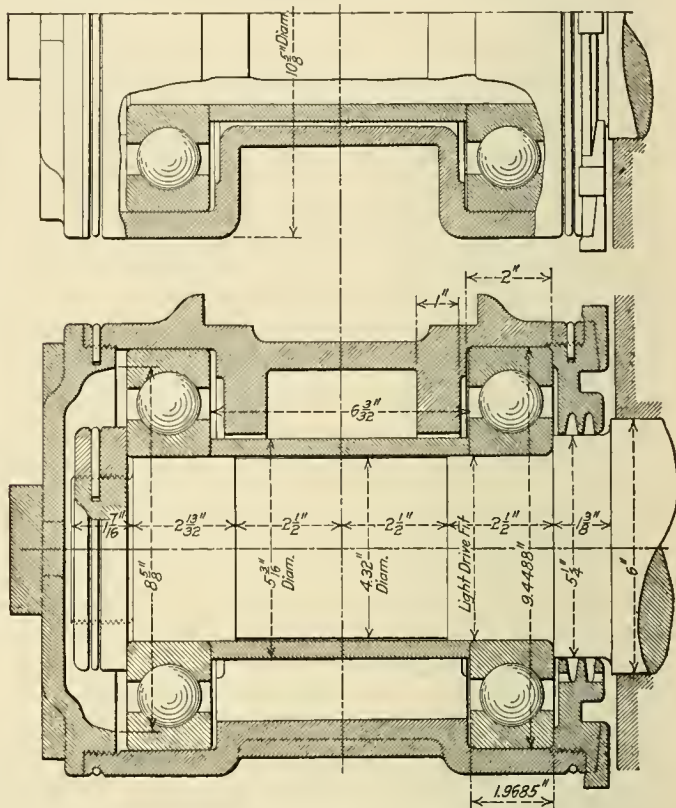

Typical Arrangement of Ball Bearing Car Journal

by the locomotive. On the up-trip which was almost continuously up grade, the train with plain bearings required about 4,900 lbs. of coal, while the one with roller bearings used but slightly over 3,200 lbs., a saving of 1,700 lbs., or nearly 35 per cent. On the return trip, which was mostly down hill, the first train consumed somewhat over 2,700 lbs. of coal, and the second 1,950 lbs., a

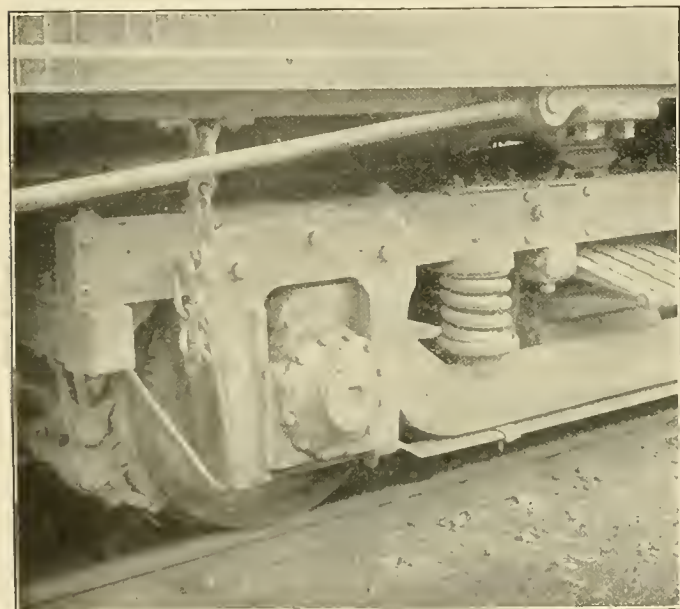

Appearance of a Truck Fitted with Roller Bearings

two coaches. The locomotive and baggage car were the same in both cases but in the first train the two coaches had plain bearings, and in the second train they were the cars equipped with roller bearings. The crew was the same on both trains. The run covered a distance of 85 miles, and a round trip was made



Heavy Interurban Car with Roller Bearings

saving of 750 lbs., or about 28 per cent. of the fuel. An inspection of the curves shows that the greatest saving was made during the acceleration and on the heavy grades combined with sharp curves. On the level the saving of coal was very small and, in fact, for certain short distances the roller bearing train seemed to consume more fuel. This is explained by the method of obtaining the amount of coal burned. The shovelfulls put on the fire between stations were counted and on some of the short sections one shovelfull more or less was a considerable per-



centage of the whole. On the down hill run the reduction in coal consumption seemed to be almost continuous during the trip. In addition to the saving of fuel, experience has shown

developed and inspection indicates that the bearings are in perfect condition.

An interesting test was made some time ago to show the de-

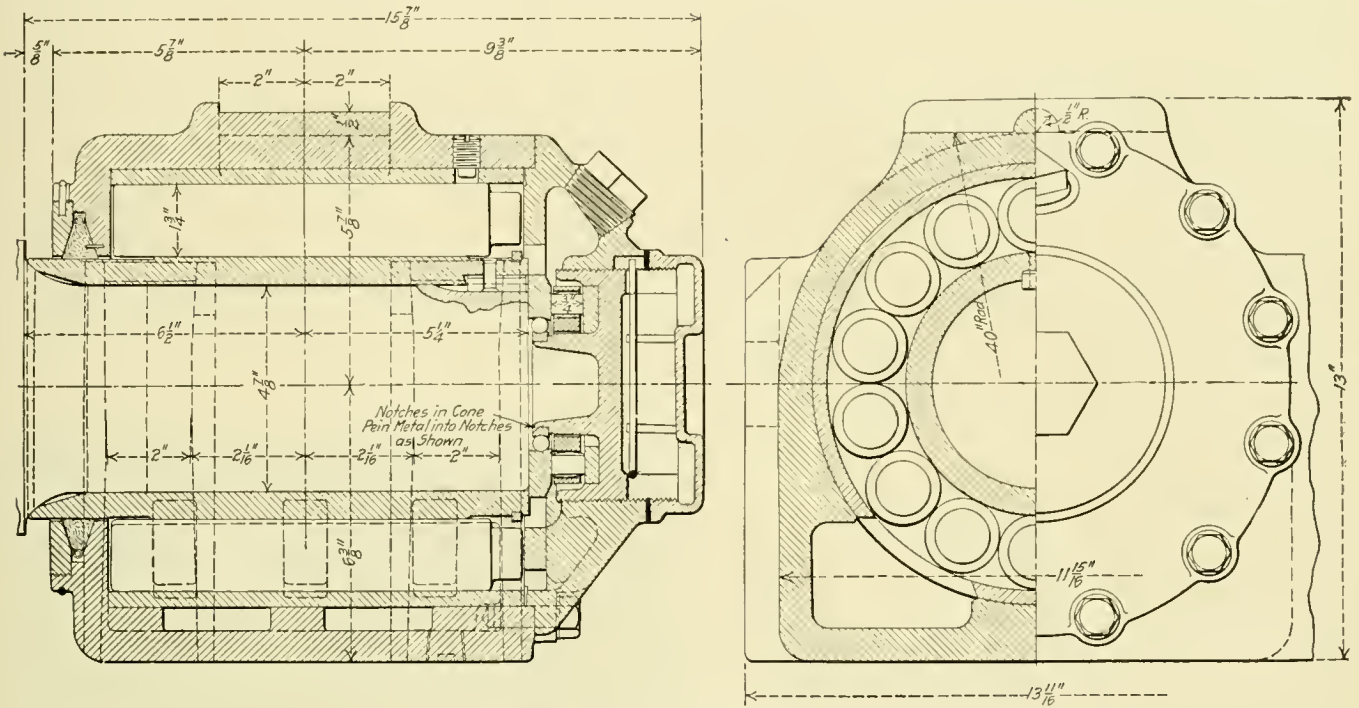

Form of Roller Bearing Used on the Bangor & Aroostook Coach

that these bearings require but about one-half pint of lubricant for nearly 5,000 miles of service. Of course no hot boxes have

creased drawbar required to start a car with roller bearings. Car No. 87 on the Bangor & Aroostook which was the first one

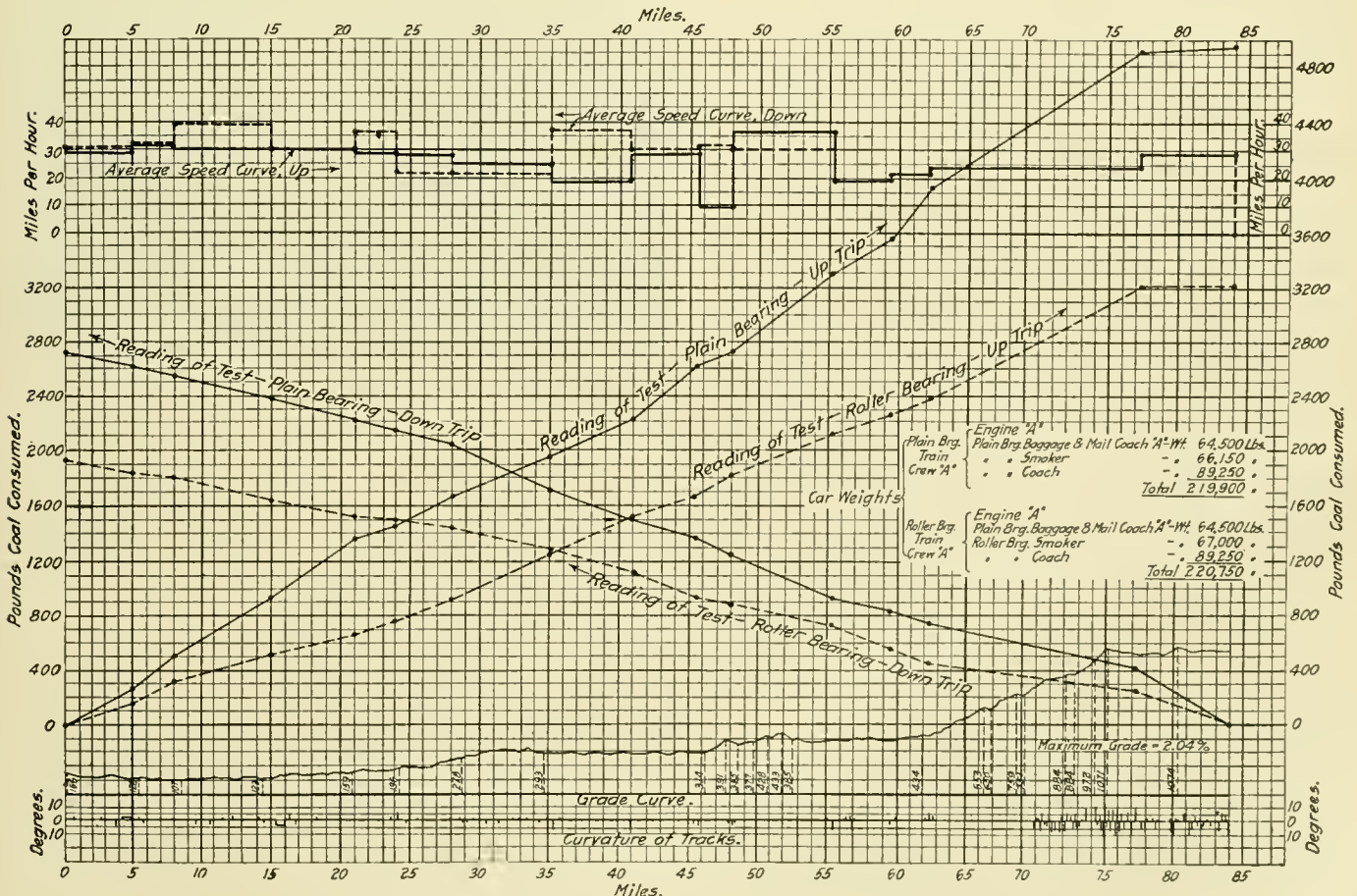

Comparative Test of Roller and Plain Bearings on the Bangor & Aroostook



to be fitted, was made up in a train with a car of the same type and weight fitted with plain bearings. The two cars were run a few miles to limber them up and the roller bearing car was then set on a piece of straight level track and the rails spotted beneath the wheels. It was found that one man could move this car in either direction. The other car was then set on the same spot mark and nine men could not move it in either direction.

A section of the bearing used on this car is shown in one of the illustrations. This section is typical of the construction used under the heavier class of cars. It consists essentially of a sleeve which fits over the journal, a casing which fits in the housing or box proper, rolls, rolling between the sleeve and the casing and a plain roller thrust bearing carried by a thrust nut, readily adjustable in the front cover. The outer collar of the M. C. B. journal is turned off and the size of the axle is slightly reduced to allow the inner sleeve to be slipped over it from the end. The sleeve, casing and rolls are made from alloy steel and are heat treated, tempered and accurately ground to a uniform diameter. It has been found that accuracy of workmanship in this connection and the quality of material are of vital importance to the success of the bearings. The inner sleeve has a snug fit on the axle and is held in place by a key. The sleeve is prevented from moving endwise by a self-contained ring on the end of the axle. There are 14  $1\frac{3}{4}$  in. diameter rollers held in a cage. The casing has an accurate fit and a bearing in the box proper for its full length and circumference. The location of the openings at the bottom for the admission of the lubricant will be seen in the cross section. The roller bearing for taking the end thrust consists of two washers or tread rings and a cage in which the rollers are contained. This bearing is made to form part of the thrust nut and is removable with it, thus making the inspection of the journal a very simple operation. As there is no part of the thrust arrangement that is subject to wear the desired amount of lateral movement between the axles and the journals can always be maintained at the most economical point. To prevent leakage of the lubricant through the rear of the box, an automatic gland is used which consists of an ordinary V shaped gland carrying a felt packing. On top and around this packing is a small coil spring with the ends joined. The tension of the spring pulls it back firmly against the axle and compensates for any wear. The sleeve is carried through the rear cover of the box to prevent the spring from forcing the packing out of place when the box is removed from the axle. To prevent leakage through the adjusting nut in the front cover the threads are made long and, as a further guard, a cap is used.

This box is slightly wider than the standard M. C. B. journal box for the same size axle and requires a different pedestal with more room between the jaws. In other respects, however, it requires no alteration of the truck or its parts. Its appearance is shown in the photograph.

It has been found that roller bearings in steam railroad service result in some indirect advantages. One of these is that the roller bearing equipment will break more rapidly and smoothly than does the standard journal. This seems to be due to the fact that when the brakes are applied on roller bearing wheels the effort is transmitted directly through the rolls to the truck frame without lost motion. When the brakes are applied with a plain bearing, however, there is a tendency for the braking effort to crowd or roll the axle out of the journal, resulting in a longer piston travel and less effect from the brake shoe. This eventually has a considerable effect on the amount of air required for braking.

STATE RAILWAY MILEAGE IN QUEENSLAND.—The total length of railways included in the Queensland state system on June 30, 1912, was 4,266 miles, inclusive of the Etheridge Railway (143 miles), which was built by a private company but is operated by the state railway department. The lines are 3 ft. 6 in. gage.

## LUNCH COUNTER CAR

The Pennsylvania Railroad has placed in service between New York and Philadelphia, on trains which also carry ordinary dining cars, an all-steel lunch counter car. It is intended to continue the experiment for a sufficient length of time to determine just which is more popular with the traveling public. The object in building the car was to see if it would permit of serving meals to passengers quicker, and thus serve more persons than is possible in a dining car.

The new car is 80 ft. long, and there is a mahogany counter extending over half the length of the car, facing which on one side are revolving mahogany chairs, secured to the floor. The counter is long enough to accommodate 21 people at one time. Back of the counter against the wall there are 20 cupboards for supplies, in addition to receptacles for crushed ice, drinking water, etc. Shelves for linen and silver occupy the space under the counter. Sunk in the counter at the end away from the



Interior of Lunch Counter Car on the Pennsylvania

kitchen is a cigar humidor, and at one end of the car there is a wash basin for the use of passengers.

The pantry and kitchen are at one end of the counter. The pantry contains dish racks, cupboard, a sink and a locker. There is no necessity for waiters to enter the kitchen. The kitchen itself is about 11 ft. long; it contains a range, broilers, steam table, ice box, coffee urn, soup receptacle and meat warmer.

VIOLATIONS OF THE ASH PAN ACT.—During the fiscal year ending June 30, 1913, three cases involving five violations of the ash pan act were transmitted by the Interstate Commerce Commission for prosecution. Defendants confessed judgment during the year as to 10 counts; 1 count was tried in court, resulting in a verdict of defendant. Penalties to the amount of \$1,200, exclusive of costs, were collected and paid into the treasury, and additional penalties in the sum of \$1,000, exclusive of costs previously assessed by the courts, were on July 1, 1913, pending payment by defendants.

# DISCUSSION OF STEEL BOX CARS

## Papers at the Meeting of the American Society of Mechanical Engineers Arouse General Interest

At the meeting of the Railway Session of the American Society of Mechanical Engineers, December 3, George W. Rink, mechanical engineer, Central Railroad of New Jersey, presented a paper on Steel Underframe Box Cars, an extract from which was published in the Railway Age Gazette, Mechanical Edition, December, 1913, page 657. R. W. Burnett, general master car builder of the Canadian Pacific, presented a paper on Steel Frame Box Cars, which was abstracted in the Railway Age Gazette, Mechanical Edition, December, 1913, page 651. This paper was read by H. H. Vaughan, assistant to vice-president, Canadian Pacific. The papers were discussed by H. H. Vaughan, Canadian Pacific; B. D. Lockwood, chief engineer, Pressed Steel Car Company; W. F. Kiesel, Jr., assistant mechanical engineer, Pennsylvania Railroad; O. C. Cromwell, mechanical engineer, Baltimore & Ohio; E. G. Chenoweth, mechanical engineer, Rock Island Lines; W. S. Atwood, chief engineer, Canadian Car & Foundry Company, and C. A. Seley, American Flexible Bolt Company. Extracts from some of the discussions are given below:

### STRESSES IN THE DIFFERENT MEMBERS

W. F. Kiesel, Jr.—The two papers on box cars form an interesting study, and will no doubt lead to a closer investigation of stresses in car structure, which in turn will tend to keep cars off the repair tracks for longer periods of time. It is also to be hoped that the recommendations for more uniformity in design will be given serious consideration, and that this may lead to a uniform design for all roads.

The tabulations given by Mr. Rink are especially valuable and present ready means for analysis and comparison of the different types of cars enumerated. It is, of course, realized that other conditions of strength must be investigated, and a paper embodying such calculations would be entirely too long. The assumptions made and the general scheme of calculation adopted by Mr. Rink are fair, and permit estimating the relative value of each car at a glance.

There is one feature in the calculations for end strength which has not been given especial attention, and that is the ratio of stress to strain under end shock. The important point to consider is at the bolster. This ratio in the fourteen cars enumerated varies between .033 and .118. The high figures are due to the great distance between the center line of the draw bar and the neutral axis of the sills. The area of the center sills at the bolster varies from 19.08 to 36.18 sq. in., and the average is 24.75 sq. in. Without using any additional metal in the center sills the ratio of stress to strain can readily be reduced in many of these cars to the advantage of the strength of the car.

Both Messrs. Burnett and Rink seem to favor the Z-bar posts and braces because they are made of rolled material, and, as stated by them, can be readily obtained. This does not seem to be a good argument, as it is well known that standard sections of rolled material cannot always be obtained on short notices; in fact, within the past year the steel mills have quite frequently reported that certain angles, I beams, etc., could not be furnished in less than three or six months, as there was no stock on hand and they did not expect to put in the rolls for that length of time.

The railroad members of the association should record their preference in regard to the various points brought out in these papers, as this will materially help designers in determining what is best to do.

The following questions seem to be of importance:

First: Is the box car with steel side frames all that it should be? It has been argued that the shrinkage of the lining, driving of nails in the lining to secure blocking, breakage of the tongues and grooves, etc., will cause leakage, necessitating constant repairs, and that the car equipped with steel sheathing and wood lining is closer to the ideal in box car construction.

Second: In box cars with outside framing, shall all posts and braces be made of rolled steel, or all pressed steel? Advocates of pressed steel assert that pressed posts and braces are lighter per unit of strength, because they can be formed to the required shape; that they can be formed with sufficient surface at the ends for the number of rivets required to develop their full strength, while Z-bars and other rolled forms require gusset plates for this purpose; that they are not likely to be damaged by pushpoles, and, if damaged in wrecks, can be readily straightened and restored to approximate shape; that when absolutely necessary to replace them they can readily be obtained from the car owner or builder and it will not be necessary to wait for any special rolling of material.

Third: Should not the posts and braces be considered strictly as beams supported at top and bottom, in combination with straight tension and compression, as members of the side truss? Mr. Rink indicates that flattening of pressed posts and braces, where they connect with the side sills, has a weakening effect, which further indicates that he considers them as cantilevers held in vertical position by the side sills and frame braces connected thereto. In wooden cars the posts and braces were strictly beams, and not cantilevers, as they rested on top of the side sills, either directly or on castings with shallow pockets. Side sills of box cars have too little resistance against torsion to hold the posts and braces vertical; they, therefore, must depend on the strength of the side plate and the tying effect of the carlines. If, in addition to this, a solidly riveted roof is used, the tops of the posts and braces are securely held in proper alinement and the stability of the side truss is assured.

Fourth: Is it not imperative to use diagonal braces in the end framing? No argument need be presented here for this, as Mr. Rink has already furnished sufficient argument, and we know of nothing to show the contrary.

It should be noted that all of the fourteen cars enumerated have so-called box-girder center sills, and that the majority of them have a minimum section of about 24 sq. in. With this section area, a ratio of stress to strain of 0.6 can be obtained, provided proper adjustment is made for relative location of the neutral axis of the center sills and the center line of the draft gear. It would, therefore, seem that the present designs of box cars corroborate the recommendations of the Committee on Car Construction of the Master Car Builders' Association and that those recommendations are reasonable and conservative. A thorough knowledge of cars by the motive power officers of railroad companies will, we hope, lead them to ultimately endorse the M. C. B. recommendations.

### IRON BOX CARS ON B. & O.

O. C. Cromwell.—The side posts and end posts, side braces and end braces, corner posts and door posts, should be brought down to a standard.

The points brought out in Mr. Rink's paper, with reference to the height of the floor above the rail, is an important one, and it appears to me that there is no good reason why we should have a variation of 6¾ in. in this height. This largely effects the height of the truck, and as it is desired to work



towards standard and interchangeable truck parts, the height of the truck is an important one to bear in mind.

In 1862 the Baltimore & Ohio Railroad built some iron box cars. These cars had wooden underframes, but the body and roof were made of iron plates. The body was about 24 ft. long, 8 ft. 2 in. wide, and about 6 ft. 6 in. high. The side and end plates were 3/16 in. sheets, applied vertically, the sheets being about 37 in. wide. The roof sheets were 32 in. wide. All sheets were riveted together at the joints. The sides were slightly convex to give them stiffness, as was also the roof. The end plates were applied perfectly straight. The sides, ends and roof were stiffened with 2 in. x 2 in. ribs, of ash.

The cars proved unsatisfactory, because in the summer time they became so excessively heated that they spoiled the merchandise, and in sudden changes of weather, produced the sweating, with damage to lading, and the cars had to be finally withdrawn from service, and used for special trade, and were ultimately converted into workmen's storage sheds, tool houses, etc.

#### LOCAL CONDITIONS AFFECT CAR DESIGN

E. G. Chenoweth.—There will perhaps come a time when the railroads have a standard design of a 30, 40 and 50-ton box car, but this in my opinion is yet far off. The general inside dimensions of a house car may be changed in the near future and again approved by the American Railway Association, which to some railroads only signifies which way the wind blows, as we must confess that the present standard is not by any means universally followed in purchasing new equipment. The great number of special cars which the railroads feel obliged to maintain for the shipment of special commodities, naturally has a tendency against the adoption of a standard box car. These special commodities are sure to change from year to year, and when the railroads meet the desires of the manufacturers, it generally means a car having some special dimensions, or perhaps different capacity from the standard car.

Before we get a standard box car, it appeals to me that three very important items entering into the problem must be solved in common with all railroads, viz.: capacity, dimensions and design.

We must consider that the railroad companies are far from agreeing on either one of the items as can be seen by reading the papers submitted at this meeting as well as checking cars in a large freight terminal.

The design of car is influenced by many local conditions as well as often a great many local instructions. It is regretted that the merits of a design of a car is too often inversely proportioned to the final weight of car. I believe that we are now about to the minimum limit relative to weight of box cars and the tendency is to increase, and not worry so much about the extra dead weight hauled, but more consideration given to keep car in revenue service more days of its life instead of standing on repair tracks.

The design of equipment is not for tomorrow or next year, but every part should do its part in prolonging the life of the car. In designing we too often leave the stress too close to the maximum allowance. This of course, to decrease weight, not perhaps making proper allowance for severe treatment or conditions which will cause distortion or rupture after in service for years. The deterioration of steel members is also an item which should be well considered.

In all designs of steel underframes consisting of two center members, I am convinced from experience, that a cover plate should be applied and that any diagonal bracing to side sill will not meet the requirements in severe service.

In the design of the steel frame box car, I am convinced that standard structural shapes with web plates need only to be used to get a first class car, and all will agree, I think, that in maintenance, the structural steel car will cost less.

In the design of steel superstructure cars, I am of the opinion that the underframe carrying members should be the center-sills and that the side sills only be of a proper section to complete the trussed panels. This will allow the superstructure more flexibility to adjust itself to irregularities of track and will not have the tendency to derail. A car held rigid so that the plane of the sides are always parallel will not properly take a curve. Where single sheathing is used the 1½ in. thickness seems to meet the requirements, and I think it should be tongue and groove instead of shiplapped. Some are using 1¾ in., or even thicker for end sheathing, but I would rather see the 1½ in. thickness used on both sides and ends and the extra reinforcement on ends furnished by proper design and locating end posts.

Of all the things which should be made standard, a box car side door is one of the most important, and should be the easiest standard to obtain and maintain. Yet few railroads have cars of different series which have doors interchangeable.

There are many designers of steel carlines, and while some answer the purpose for which they are designed, others are a joke. The tendency is to figure a carline for strength at the center, forgetting all about section near side plate. One function of the carline is to keep the side plates from going out as well as coming in, and therefore, it should not be designed to support the roof only.

I am of the opinion, that if need be, we should sacrifice head room to get carlines nearly straight on the bottom edge which will act as a tie rod in tension and be in best of shape to withstand compression.

The draft gear and application of same to car is the most important detail of any car, and this fact is appreciated by all railroad men; yet, what great diversity of opinion among them as to what is best. Many are holding to a spring gear, while others, claim that the friction gear is best. Does the good obtained from the use of friction gear warrant the extra expense?

We should have a minimum allowable area for draft sills and this should be effective area as well balanced about the line of draft. I have often wished that the standard draw bar height was increased at least 1 in., which would allow a better application of the high capacity draft gears.

#### VENTILATED ALL-STEEL CARS

C. A. Seley.—About fifteen years ago three factors influenced some progressive railroads to the larger introduction of steel in frame work of freight cars; increased capacities, greater structural strength to withstand operating stresses, and the approaching equalization of costs of steel and car lumber, particularly for framing.

For new cars, I believe there is now no good argument as against steel for the complete framing, so combined that the sides will assist in carrying the load. The question then arises as to how far to go with the use of steel for such parts of the car as merely contain or shelter the load. Manifestly, floors must continue to be made of wood to enable blocking of the lading. Aside from this, there are many predictions of all steel box cars. In my opinion, this will be the ultimate construction, but doubtless slow in general adoption account of the still favorable balance in favor of the cost of wood for lining and sheathing, and in combination with steel plate for roofing—whether of the so-called outside or inside type.

When the all-steel box car does come, it will have to be arranged with ventilation features to prevent damage to lading from sweating and from accumulation of excessive heat which may unfavorably affect many high grade commodities if shut up in a steel box without such ventilation.

Both writers have discussed the advisability of the "standard" car. I doubt very much if this idea will ever be consummated, even to the extent of the standard material idea advanced by Mr. Burnett. The difficulty in the way is the human element.

If we all thought alike we would all wear blue suits and red ties. The M. C. B. Association has standardized the parts essential to interchange, and under this head may be listed couplers, air hose, wheels, axles, journal boxes and contained parts, brake shoes and brake gear parts. The government has standardized safety appliances.

This all sounds fine, and to the uninitiated would seem to settle most of the difficulties in car repairs, but we all know that very few of the M. C. B. standards are really standard in exact detail, and the Interstate Commerce Commission safety appliances necessarily give considerable range of dimensions and applications within which their requirements may be fulfilled.

It is difficult for one not in railroad service to appreciate the whole problem, and particularly the influence of interchange requirements. A railroad may be of low gradient, equipped with light power, and have a class of traffic that would ordinarily keep their cars on their own line, and the cars which would most economically fulfill all requirements for such a line and service can be readily imagined. In interchange, however, these cars might be required to go anywhere from coast to coast, in all kinds of tonnage trains, through hump yard trials and other tribulations never experienced on the parent road.

A railroad car designer can never afford to worship standards in view of the rapid evolution in transportation.

#### STANDARD CAR IMPROBABLE

H. H. Vaughan.—I do not believe that we are ever going to adopt one standard type of car or one standard design of car and build it indefinitely. There are sure to be improvements and alterations that the different roads think it desirable to make, and if we had a standard car tomorrow the next order that was let would have a few changes from it, and if we use standard material and material that can be obtained without difficulty, and keep to certain standards on the parts that both Mr. Rink and Mr. Burnett have mentioned, I think that we are going as far as we can go in the direction of a standard car.

I quite agree that the draft castings, arch bars, bolsters and some of the other parts should be standardized to a greater extent than at present. It does seem absurd that the slight variations made in these parts should necessitate their being obtained from the car owners, when repairs are to be made on foreign lines, and that serious delays should ensue on account of these parts not being available.

Some of the features of the underframe design of the C. P. R. car were not altogether a question of engineering, but were largely governed by a feeling I had that if you make a thing plenty strong enough you never lighten it, and that if you will get a new design a little fine and then strengthen it, in the weak points, you will finish up with a considerably lighter design than if you started out with some arbitrary figures and made everything plenty strong enough to start with.

In designing a car you have got to figure the service the car is generally going to run in, not the service it may run in. We figured that 60 per cent. to 75 per cent. of the service to which the box cars are put, both in Canada and in the United States, is service in which this type of underframe will stand up perfectly satisfactorily. I feel that that assumption is justified by the results we have had with this type of car. If there was any decided weakness in this type we certainly have found it out in five years.

The fact that we have had 14 or 15 cars destroyed on foreign lines indicates that, while the construction may not be as strong as would be desirable for some service, it is strong enough for the average service in which the cars are used. I do not believe today that it is a good commercial proposition to put weight on to a car for occasional service. We have never, as far as I know, had a single car that has shown vertical weakness in the center sills.—The omission of that cover plate has introduced a certain amount of longitudinal weakness through the center, as well as buckling sidewise, but in no case buckling ver-

tically. We expected that the floor would be sufficiently stiff to prevent any lateral buckling of the center sill, and we have had some floors that were so loose that I do not think they have acted that way, if the car has been permitted to buckle. The center sills and the side sills have ample strength to hold up the corners of the cars under general conditions, and the carving of 500 lb. weight there, and 500 lb. in the cover plate, and a few hundred pounds here, and a few hundred pounds there, is what has made that car the light car that it is as regards its weight. We have a car weighing 36,500 lbs. and carrying 40 tons, and which can be loaded to 93,000 lb., before exceeding the permissible loading on the axle.

I want to call attention to one point of view, and that is the advantage of reduced weight on net earnings, and not on the cost per ton mile. Taking the figures for the Canadian Pacific in 1913. We carry 22.34 tons per loaded car mile, and our percentage of light car mileage was 28.5 per cent. of the loaded car mileage. That gives an average load of 16.8 tons per car mile total. The average weight of light car is about 18 tons, giving an average weight of loaded car of 34.8 tons. Supposing that the car weighed one ton more. Then there would be an increase of the ton mileage of 2.85 per cent, or if you were formally operating on a ratio of 70 per cent, under this changed condition of weight, you would be operating on a ratio of 72 per cent. The net tons would go down from 30 per cent to 28 per cent, which is a difference of 6 per cent; in other words, while you have only changed 2 per cent in your cost of transportation, you have changed about 6 per cent in your net earnings, and net earnings are what we are after.

I think the question of weight is something which must be looked after carefully in car design; we must not design cars that are cheap to keep up altogether, and cars which will not need repairs, but try to design a car that is most economical for the railroad company to handle its traffic. It may cost \$5.00 or \$10 a car more a year to keep up, but it will save two or three times that in the weight you are hauling about uselessly.

In reference to vertical or horizontal sheathing, I agree with Mr. Rink. Mr. Burnett stated that there were a number of cars which were quite open. We have had a lot of cars which have shrunk to an extent to cause us a great deal of anxiety, but we have had singularly few cases of damage claims on account of it. These planks are all ship-lapped, and even when looking at a car you would think you could see through the openings. It is rare, however, for us to get any complaint. As Mr. Burnett says, it is not difficult to tighten them, and the only reason we have not tightened them is because we have not had sufficient complaints to justify our taking the cars out of service and doing the work. The vertical sheathing would be, possibly, a preferable arrangement if you could accompany it with an economical and convenient design of side framing. This is a difficult thing to do—the truss form of side framing naturally lends itself to horizontal sheathing. If you go to vertical sheathing, you will have to introduce horizontal members to take care of the fastenings. The distance from the top plate to the sill is too great to permit side sheathing to get any support if placed vertically.

I would be very glad, while we are here, to hear any discussion from the members present on the roof question. The fight seems to be one between the three different types of roof which Mr. Rink describes. The road I am with has been an advocate of the inside metal roof so long, that while we are experimenting with the all metal roof, we are rather wondering why we are doing it. I know that quite a number of our members here have used extensively the all metal roof, and we would be very much interested to know what results are obtained from that style of roof in comparison with the older type.

RAILWAY CONSTRUCTION IN ITALIAN TRIPOLI.—Nearly 60 km. of railways are said to have been built in Tripoli since the war of the Italians against the Turks.



### STEEL TRUCKS FOR PASSENGER SERVICE

The Canadian Pacific has in use a type of four and six-wheel steel truck for passenger train cars that was designed by the general master car builder, R. W. Burnett, and which has proven to be very efficient. The general appearance of the two trucks is clearly shown by the illustrations from photographs.

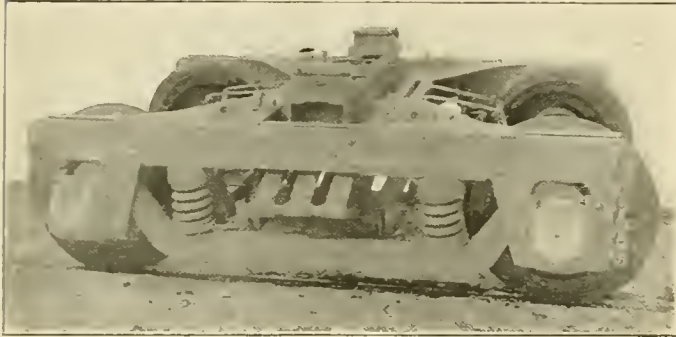

Four-Wheel All-Steel Passenger Truck

while the details of the construction of the six wheel truck is illustrated by the line engraving.

There are a number of points about the truck that at once attract attention. First is the smooth straight line external ap-

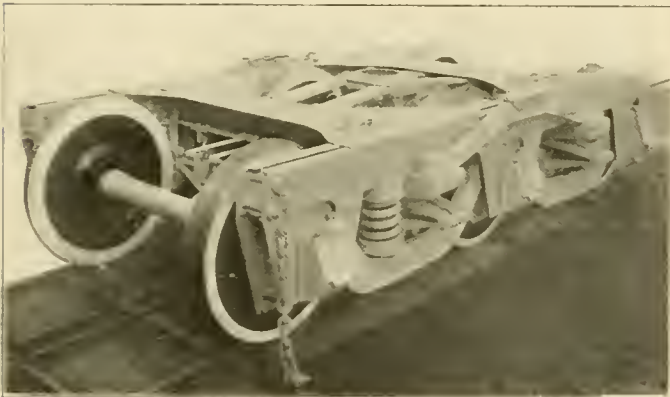

Six-Wheel All-Steel Passenger Truck

pearance with the omission of the usual end pieces. The absence of the end pieces gives a better clearance for the car steps and allows a better opportunity not only to strengthen the draught rigging but to inspect and maintain it. On the end toward the

center of the car there is a better opportunity to install the axle light apparatus.

The side beams are formed of two 8 in. channels, with their flanges toward each other. They are riveted together with spacing blocks between so that they present a smooth surface on the outside. The two beams thus formed are tied together by Z bar transoms and straight gusset plates extending all of the way across the truck at both the top and bottom of the channels. At the pedestals the lower flanges of the channels are cut away to admit the equalizers and are, at the same time, stiffened by the pedestal plates. These are made of flat plates which are first punched approximately to shape, and then milled to the exact size. In designing the truck, it was expected that these pedes-



End View Showing the Brake Beam Adjuster and the Absence of the End Piece

als would bend in case of a derailment, but that they could easily be bent back again into shape. Experience, however, has shown that whenever a derailment has occurred the pedestals have not been distorted and it has been possible to carry the car body to the shops on its own trucks.

For wearing strips, chilled cast iron liners are riveted to the jaws, and these have shown wearing qualities superior to anything else that has been tried. Neither liner nor box has yet shown any appreciable wear and the indications are that both will run indefinitely. At the bottom, the jaws are tied together by a short pedestal tie bar held in place by a pin, fitted with cotter and without bolts or nuts. To remove a pair of wheels,

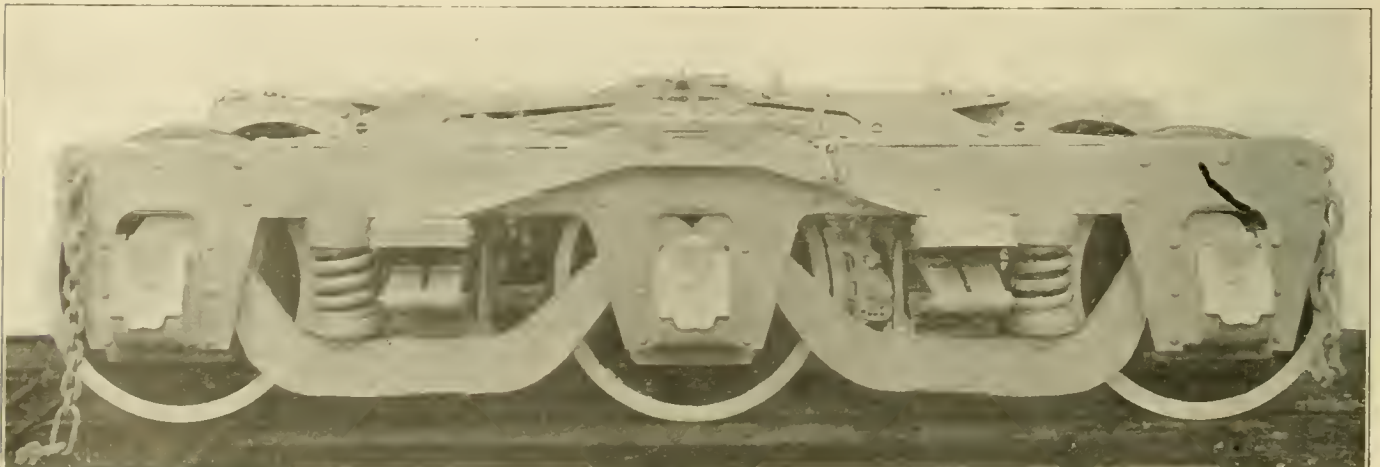

Another View of the Canadian Pacific All-Steel Six-Wheel Truck for Passenger Equipment





all that is required is to take out two cotters for each pair of wheels, pull out the pins and lift the frame.

The absence of the end pieces necessitated the use of inside hung brake beams, and these are installed without any retracting springs, but with a special brake beam adjuster. This is very clearly shown in the enlarged end view of the six-wheel truck. It consists of a hanger carried by arms riveted to the transom. Into the bottom of this hanger is screwed the carrier that supports the truss of the brake beam. No check nut or cotter is required to hold it in place, as it cannot turn and the adjustment is effected by removing the pin from the brake beam, screwing the carrier to the proper position and replacing it in the beam.

Bolts and nuts are avoided and one of the arrangements for doing this is to be found in the bracket for the spring plank hangers. It will be seen that these are on top of the gusset plates. They are simple castings with a seat for the hanger pin. This pin is held in place by a wall over the hole at one end and a cotter pin put across the hole at the other end. To remove the pin, a hole is left in the wall, through which a drift can be pushed or driven.

In spite of the substantial appearance and actual strength of these trucks they are lighter than the composite truck which they replace.

## INTERSTATE COMMERCE COMMISSION AND STEEL CARS

In its last annual report the commission noted that the railroads were making progress in the substitution of steel and steel underframe passenger cars for those of wooden construction. The superiority of these modern cars over the old style wooden cars has been amply demonstrated by their performance in both collisions and derailments, and to insure that all carriers make proper efforts to procure these modern cars legislation should be enacted prohibiting the use of wooden cars in high speed through train service after a certain date. Reasonable time should be given the carriers for compliance with the provisions of any law of this kind, and its application in the first instance should be confined to important high-speed trains. There are a great number of wooden cars now in service, and the carriers should be permitted to make use of these cars on branch lines and in local service until they can be replaced by steel equipment, but the law should provide that all new cars constructed after a certain date should be made either entirely of steel or of steel underframe construction of an approved design.—From the twenty-seventh annual report of the Interstate Commerce Commission.

**SARATOGA AND SCHENECTADY RAILROAD.**—The locomotive engine commenced its regular trips on this road on Wednesday the 28th ult.; on which occasion a party of gentlemen from this village and Ballston Spa, were politely invited by John B. Lasala, Esq., one of the directors and a principal stockholder, to join in the festivities of the occasion. They repaired to Schenectady in a railroad barouche, where they were joined by two of the directors. The engine left that place a little before 12 and reached this village, drawing a train of 12 or 14 carriages and wagons, in one hour and twenty minutes. The travel is continually augmenting, and it is a source of no small pleasure, that the various estimates of income heretofore given are likely to be more than realized. Though not immediately connected with the work, we cannot but feel a deep and lively interest in its prosperity, and in everything pertaining to the welfare of its stockholders. Another engine, we understand, will be placed on the road in a short time.—(Saratoga Sentinel.) From the *American Railroad Journal*, June 7, 1834.

## CONVERTIBLE BOX AND STOCK CAR

On a number of roads serving the stock growing districts there are certain times of the year when stock cars are required in large numbers, and in order to supply the demand it is usually necessary to operate many trains of empty stock cars, while at



Car Ready for Shipping Stock

the same time loaded box cars carrying general merchandise are moved in the same direction and frequently are returned empty to the originating point. For a number of years E. D. Levy, assistant general manager of the Frisco lines, has been endeavor-



Car Ready for Shipping Merchandise

ing to decrease this cross hauling of empty cars. Attempts were made to use the stock cars for carrying general merchandise, the roof and sides being covered with tar paper for this temporary use. This, however, was unsatisfactory on account of

the construction of the cars, and only a small percentage of them could be used in this way.

In order to obtain a stock car that could be more readily con-

verted to a box car, and only a small percentage of them could be used in this way. With these exceptions the car is essentially identical with the new Frisco box car, described in the October, 1913, number of the Railway Age

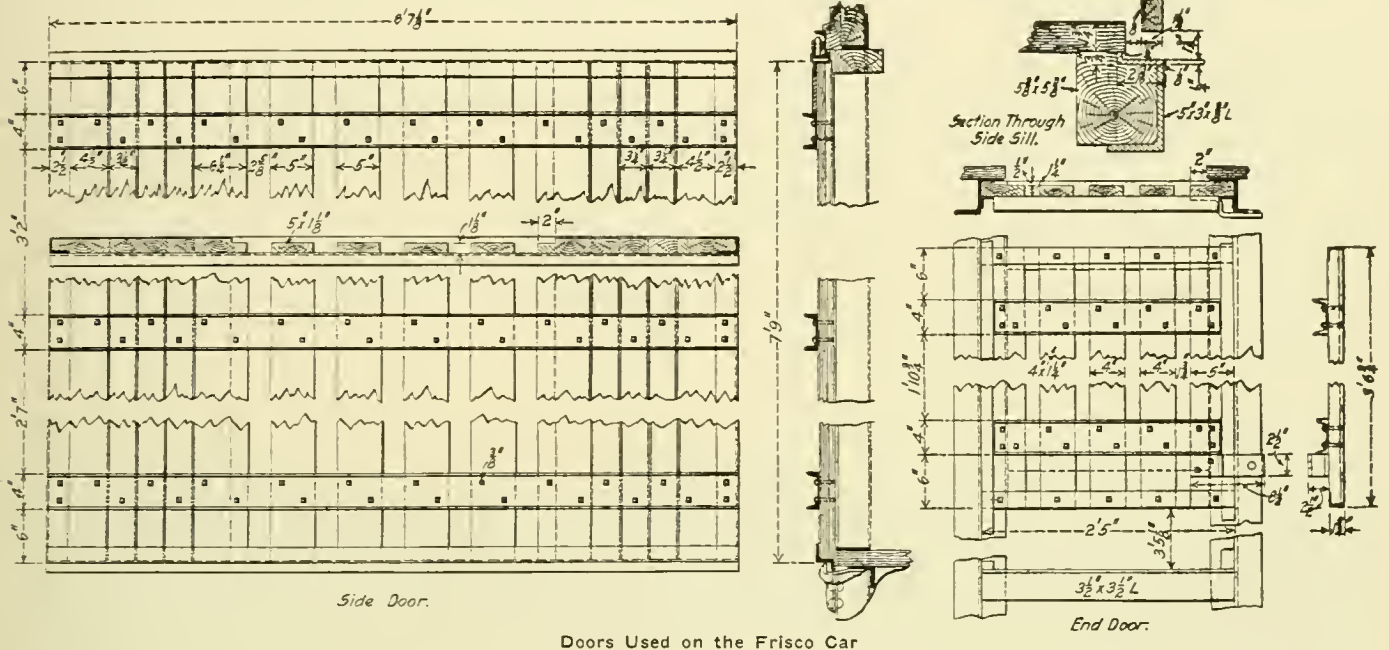

verted to a box car, a new car was designed by Mr. Levy as shown in the accompanying illustration. This car is simply a box car provided with slats, and has a special design of floor

Gazette, Mechanical Edition, page 555. There is also a further difference in that the Chicago-Cleveland Car Roofing Company's type B Improved Winslow roof, with angle steel carlines and

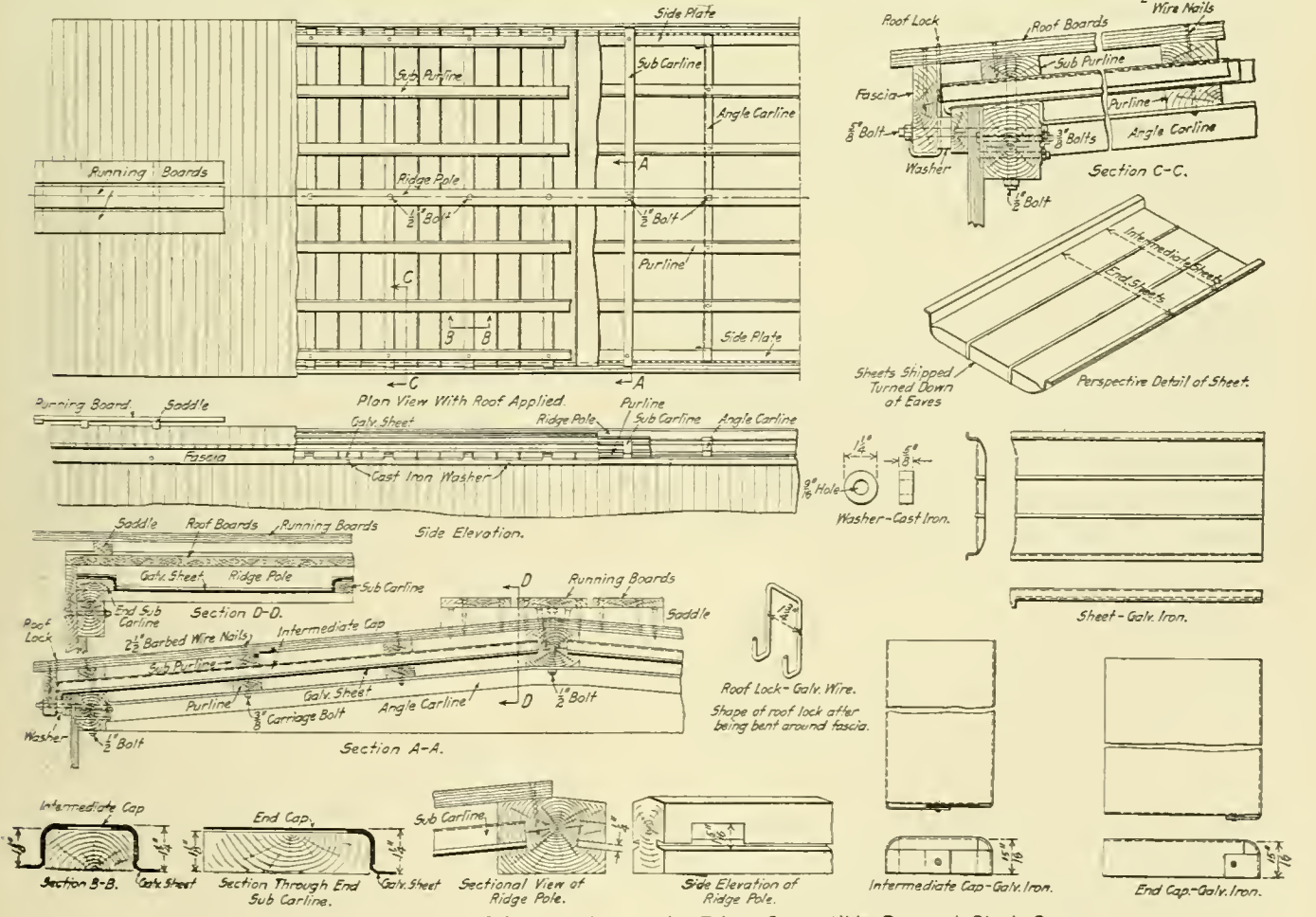

Details of the Roof Construction on the Frisco Convertible Box and Stock Car



X brace, is used on this car instead of the outside metal roof.

The car is designed for a capacity of 80,000 lbs., and has the outside steel frame superstructure. The arrangement of the side framing is clearly shown in the illustration. The solid siding extends to a point about 5 ft. 3 in. from the floor. The slating is 1 1/2 in. thick and 5 1/2 in. wide, and is fastened to the posts and braces by 1/2 in. carriage bolts. The opening between the slats is 1 3/4 in. The end construction is the same as that for the box cars. It will be noticed in the section through the side sill that the floor of the car is 1/2 in. above the bottom of the lowest slat, and an opening of 7/8 in. is made between the floor and the car siding. This is to permit drainage of the car when used as a stock car, and also to allow the tar paper to be extended below the floor when converting to a box car, so as to insure positive drainage from the sides in wet weather. Two strips of tar paper are used on the inside of the car to cover all the openings between the slats, and are lapped so that the moisture cannot work through to the inside of the car. The tar paper is held in place by laths, used as cleats, nailed to the slats. The slats in the door are 1/2 in. thinner than the edges of the door, in order

of 1,000 cars, the saving in interest, maintenance and depreciation on which would amount to about \$170,000. Therefore the total net saving would be in the neighborhood of \$205,000, or \$102.50 per car per year. While this car might be used both as a box and stock car, a road would not be warranted in replacing all its stock cars with this type of car, but a careful analysis of the empty cross hauling would clearly show what percentage could be used to good advantage.

These cars were built in the company's shops and the selling rights have been granted the Chicago-Cleveland Car Roofing Company, Chicago, for the convertible features, a patent for which has been applied for by Mr. Levy.

The general dimensions of the car are as follows:

Inside length .....	40 ft.
Length between end sills.....	40 ft. 11 in.
Length over running boards.....	42 ft. 1 in.
Length over striking castings.....	42 ft. 3/4 in.
Center to center of bolsters.....	31 ft.
Width inside .....	8 ft.
Height from top of floor to under side of carline.....	8 ft.
Height from rail to top of floor.....	4 ft. 1 3/4 in.

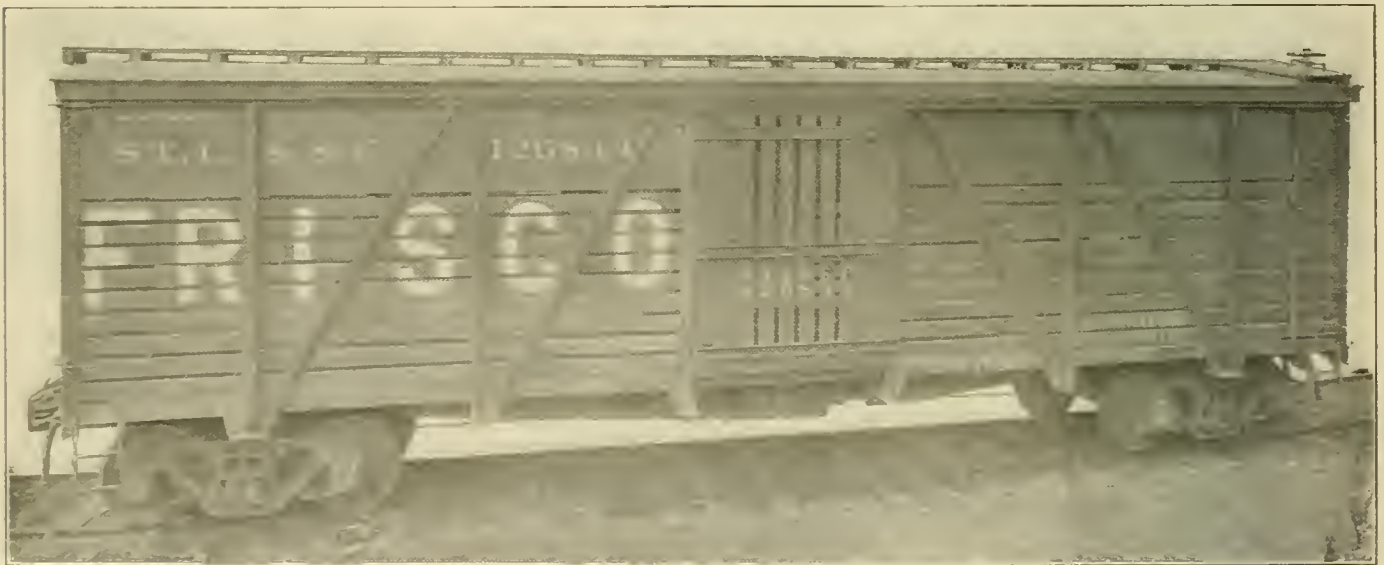

The Frisco Car May Be Used Either as a Box or a Stock Car

Height from rail to eaves.....	12 ft. 5 3/8 in.
Width of side door opening in clear.....	6 ft.
Height of side door opening in clear.....	7 ft. 6 3/8 in.
Truck wheel base.....	5 ft. 6 in.

to permit the tar paper being applied without interfering with the action of the door.

The double roofing has been found to be cooler by an average difference of about 4 deg. than the single or outside roof throughout the very hot weather, and this feature is of advantage in stock cars, especially when carrying hogs.

With a design of this kind, the total number of cars used in the stock growing territory may be materially reduced, since box cars running out of the stock market may be used to carry general merchandise and freight moving in packages, bales, boxes, barrels or other containers which are being sent into these districts. On the return trip the temporary sheathing may be removed and the cars loaded with stock. In this way it has been estimated that about 2,000 such cars would do the work of 3,000 straight box or stock cars on the Frisco Lines. It was estimated that these 2,000 convertible cars would save about \$162,000 in transportation costs, due to the hauling of empty cars. To be conservative, however, the actual saving is considered only one-half of the theoretical saving, or \$81,000; this provides for cases where it would not be possible to use some of the cars on the return trip. The cost of converting one of these cars is about \$2,00, which it is estimated would amount to \$46,000 on the 2,000 cars for one year, which would make a net operating saving of \$35,000. Since these 2,000 cars would replace 3,000 straight box or stock cars there would be a saving

INTERNAL COMBUSTION LOCOMOTIVES.—The internal combustion locomotive as a factor in main line locomotive practice has now passed the proposal stage, and a number of interesting designs are available for consideration, though as yet practical realization is confined to a very few specific instances. According to the Railway News a design recently made public includes two internal combustion engines, each driving an axle through clutches, arranged one at the front and one at the rear end symmetrically to a vertical plane through the center of the locomotive. The axes of the engine cylinders converge upwards towards the central vertical plane, and the driver's stand and water tank are arranged in the center. The cooling water for the engines is circulated by pumps through coolers arranged one at each end of the locomotive. Each engine is clutched to its axle by a pneumatically operated clutch. The arrangement, therefore, produces a 2-10-2 design, with cooler and diagonal engine at each end and driver's cab in the center, the respective engine shafts being between the leading—or trailing axle, and the driving axle next thereto, gearing transmitting power to the five driving axles, which are actuated through the pneumatic clutches mentioned.—The Engineer.

# SHOP PRACTICE

## NOTES ON APPRENTICE INSTRUCTION

By H. E. BLACKBURN

Instructor of Apprentices, Erie Railroad, Dunmore, Pa.

Shop education in connection with the apprenticeship system has been adopted by the majority of railroad companies. Each company has organized it according to its needs, and today some companies have systems as carefully graded as any technical school course.

Sixty years ago, when setting a slide valve on a locomotive was considered almost a trick in magic, some parent who had boys to spare would select the one he liked the least and drive him off to a magistrate, who in turn would bind the boy over

Parents blame the schools for not educating their children so that they can earn a living, but for every hundred boys entering the primary grades 55 leave before they reach the last grammar grade, and only four out of the hundred graduate; in other words more than one-half of the children leave school before they receive enough education to work common fractions. Large numbers of boys flounder about trying to do something for which they are not fitted, in many cases just because the parents do not wish to have them soil their hands. False pride has made more low grade doctors and lawyers out of material that nature intended for mechanics, than any other one cause.

We should not lose sight of the fact that the bulk of the American people are wage earners and that there will be more



Erie Railroad Apprentice School at Dunmore, Pa.

to some machine shop owner. The master promised to teach the boy the trade, supply him with board and clothes for the next seven years, and for all this he was to give the boy's parents the magnificent sum of \$5 a year.

Today the railroad companies are making diligent search for apprentices and they are offering as an inducement free instruction in their schools, with a three years' course in the shop and more pay in 30 days than the boy of old received in 365 days. And all this with the entire elimination of petty restrictions.

Today's greatest problem in the labor world is to find skilled help, or the material from which skilled help can be developed.

and more of them needed. Upon the wage earners falls the task of educating their children so that they may fill these places, and what is most needed is a good grounding in plain reading, writing and arithmetic. While it is true that many children have to leave school early, it is also true that many of them wish to.

A western railroad apprentice educator asks why a railroad should be asked to educate its help when the people pay taxes to have it done at school. In general the schools do not even aim to find out what the child is capable of doing so that he may intelligently approach his life work.

A great problem in apprentice school work is to secure a man



as an instructor who understands what is actually going on in the shops and can impart this knowledge to the boys. It requires a good judge of human nature to pick out the right boy for a trade, and the use of tact to keep him on the pay roll. Nagging or unreasonable instructors never succeed with boys who are worth while.

It is poor practice to forget all about the boys during the evenings, for this is really the best time to recruit material so as to fill up the ranks of graduating apprentices. If a teacher waits and takes what comes along he will generally be disappointed. The place to find boys of the right caliber is in the night schools and Y. M. C. A. classes, or about the libraries. The teachers of the industrial art schools are always willing to unload their surplus graduates on the shop schools, and unless the instructor chooses carefully in such cases he is likely to lose his reputation as a vocational guide.

Apprentice boys must be taught to think and act for them-

is good practice to detail him as an assistant instructor in order to show the next boy in line how the work is done. As a teacher, the boy gains valuable experience and his ability is tested. The apprentice under this system gains confidence in himself and his ability is often recognized long before his apprenticeship is finished, so that he is guaranteed steady employment on some work that will in time lead to a foremanship if he continues to improve.

TUNNELING THE ENGLISH CHANNEL.—Baron d'Erlanger, chairman of the Channel Tunnel Company, lecturing recently in London, on the construction of the channel tunnel, said the line of the proposed tunnel would be from behind the forts at Dover, dipping down under the Channel to a maximum depth of 100 yards and then rising gradually to the French shore. Beneath the main tunnels, in which ultimately the trains would run, would

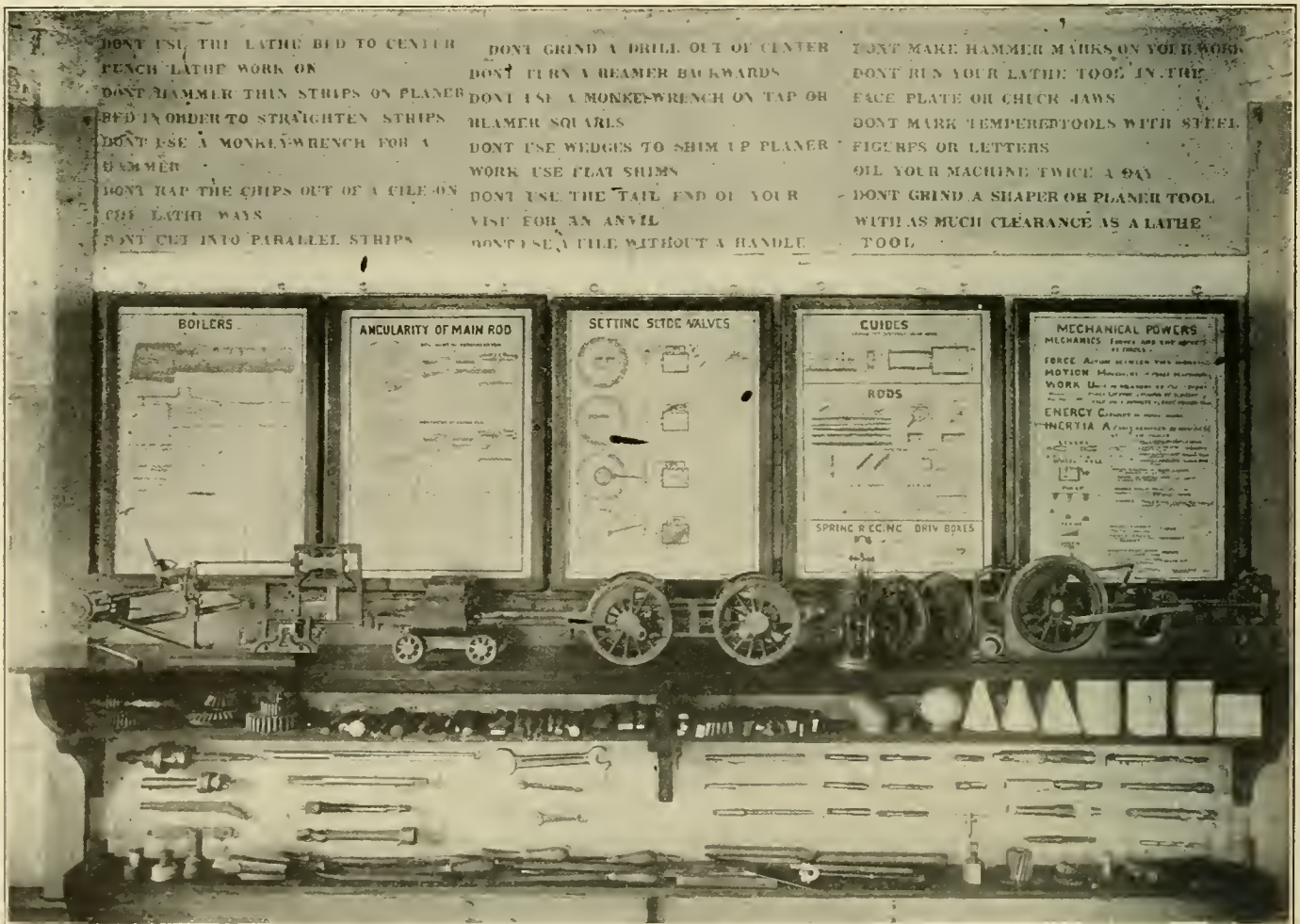

Charts, Models and Tools in the Erie Apprentice School at Dunmore, Pa.

selves. The most successful way of accomplishing this is by the use of charts and models of the work. These greatly increase the boys' interest and help them to remember, as pictures of them become registered in their minds. Modern shop education should include both practice and theory. For his practical experience the boy should work in the shop on a regular machine, or at the bench. His product should be examined by the foreman and the instructor, and he should be advanced in the work according to his ability as a mechanic regardless of the time he has served at the trade. The theoretical work should be most carefully studied and should consist principally of mechanical drawing and shop mathematics. When a boy is about to leave a machine on which he has become proficient it

be a small drainage gallery, and it would be by using this gallery for a small line of railway that the 1,200 workmen would be conveyed to the scene of operations every morning and the debris brought out. Sir Francis Fox, engineer of the company, said he had spent the best part of forty years of his life tunneling under water and through mountains and under the streets of London, and had had far greater difficulties to contend with than they expected to encounter in tunneling the channel. For example, they would have no scalding water or hot rocks to deal with, as in the case of the Simplon Tunnel; nor would they experience the difficulty they had in driving a tunnel under the Mersey from 1880-86. Difficulties and risks were today reduced to a minimum.—*The Engineer*.



# AN EFFICIENT WHEEL SHOP

## The Methods and Equipment Employed in Car Wheel Repairs and Renewals on the Soo Line

BY B. N. LEWIS

Assistant Foreman, Shoreham Shops, Minneapolis, Minn.

The wheel shop of the Minneapolis, St. Paul & Sault Ste. Marie, at Minneapolis, is a good example of what may be accomplished, in laying out a shop, by making a careful study of the work to be done. When the space first allotted to this

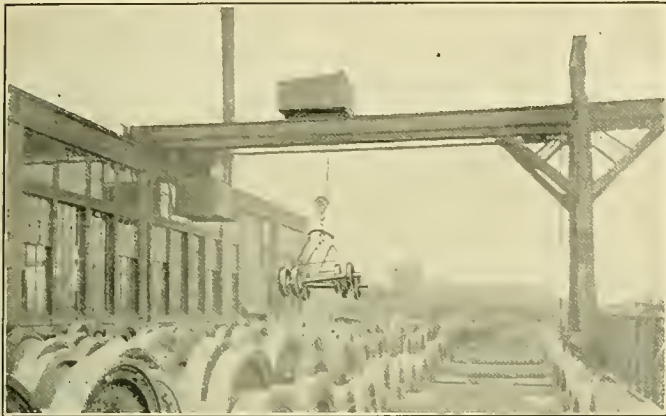

Fig. 1—Platform for Storing Mounted Wheels

work had been outgrown a new shop was planned and built by the local forces, and, while there have been a few changes in the locations of the different machines, the shop has proved to be efficient from the start. With the present equipment it has a capacity of 2,000 pairs of wheels a month. Under average conditions, however, the shop has an output of 1,500 pairs of wheels, with 18 men working 25 days of 9 hours each, at an

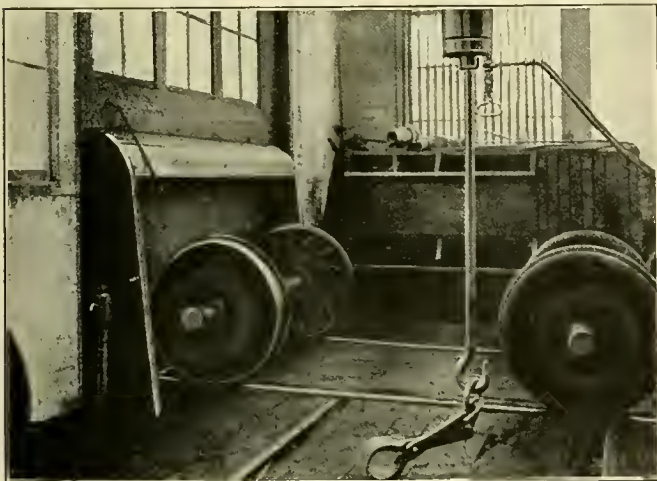

Fig. 2—Balanced Doors for Mounted Wheels

average cost of 84 cents per pair of wheels. This includes the turning or re-tiring of about 210 steel tired wheels, dismantling all scrapped wheels, handling all new and scrap material, loading and unloading all wheels, checking, accounting, etc.

The shop has a depressed spur track on each side with a 40-ft. platform on the south side, and a 50-ft. platform on the north side. Both platforms are level with the car floor. The 40-ft. platform is used for storing unfitted wheels, axles, tires, etc. The floor of this platform is made of old car sills and is

of sufficient length to accommodate six cars at one time. The 50 ft. side is equipped with tracks for storing the mounted wheels. The wheels are also received on this side from the road, the cars being unloaded by means of a 5-ton Gantry crane, as shown in Fig. 1. It will be noticed that a special hook is provided that will lift four pairs of wheels at a time just as they are located on the car.

As the worn wheels are taken from the car they are placed on

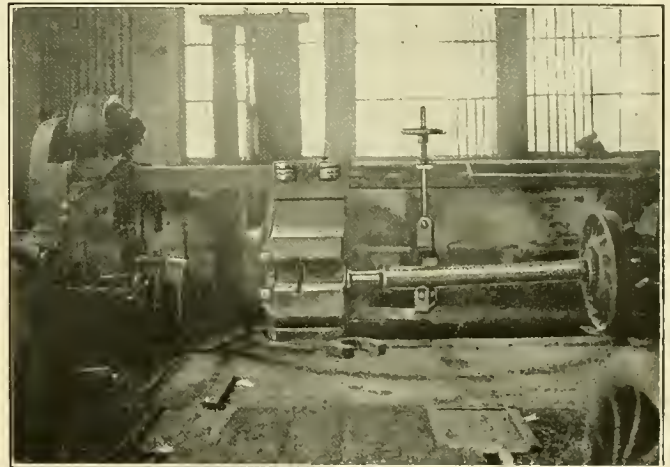

Fig. 3—Dismantling Press Showing Scrapped Wheel Ready for Lifting

a transverse track entering the building at the east end, and are passed through a swinging door, shown in Fig. 2. There are two such doors used in the shop, the other being at the west end on the same side where the finished wheels are run out of the shop. These doors are made of wood covered with sheet

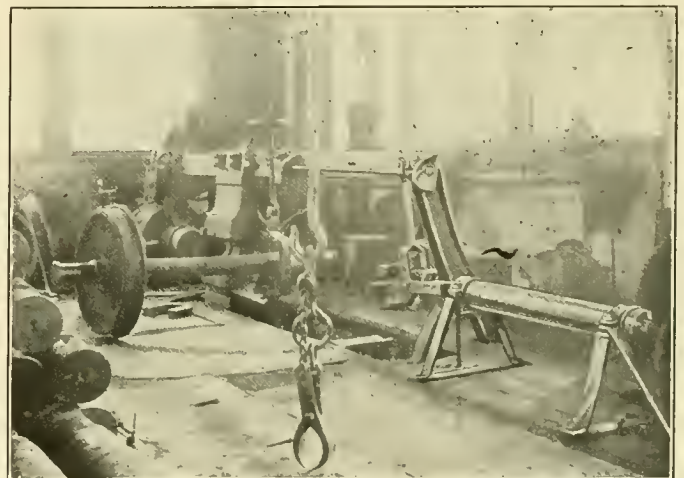

Fig. 4—Another View of the Dismantling Press Showing Air Cylinder and Grab Hook

iron and swing on a pivot near the top. Weather strips are provided on all four sides. They are easily operated by simply pushing the wheels through them. They will allow very little cold air to enter the shop, and are an excellent arrangement,



Both from the standpoint of time and of keeping the shop warm in winter.

After the wheels have been pushed through the swinging door they continue across the shop, the track having a slight descending grade to the dismounting press shown in Figs. 3 and 4. This press is arranged to be operated by one man and has many unique features. The platform in front of it is removable, being set flush with the floor for 33 in. wheels, and may be re-

jaw is placed on a small carriage to facilitate this operation and the axle is supported by a swivel hook provided with a roller;

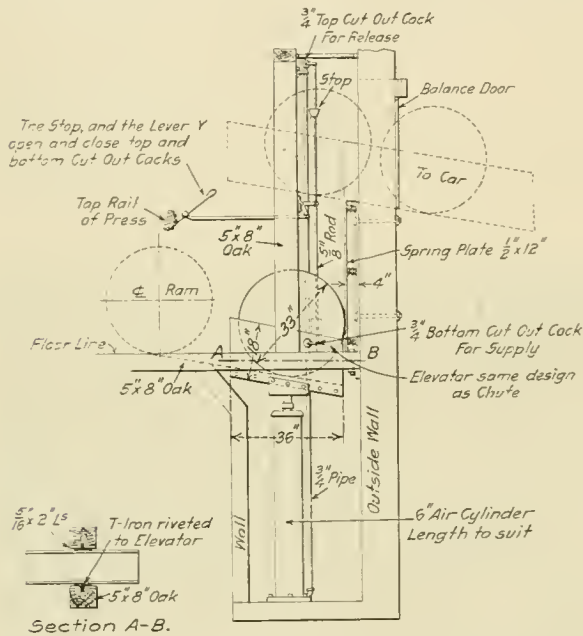

Fig. 5—Hoist for Lifting the Scrapped Wheels

placed by others of different heights to facilitate the handling of wheels of different diameters, the purpose being to have the axle in line with the jaws of the press. The top of the platform is covered with an iron plate.

When a wheel that is to be scrapped has been removed from the axle it is rolled down a short incline back of the machine to an air lift, a drawing of which is shown in Fig. 5. The wheel is then raised and placed on a chute which passes through the side of the building down to the south platform where the

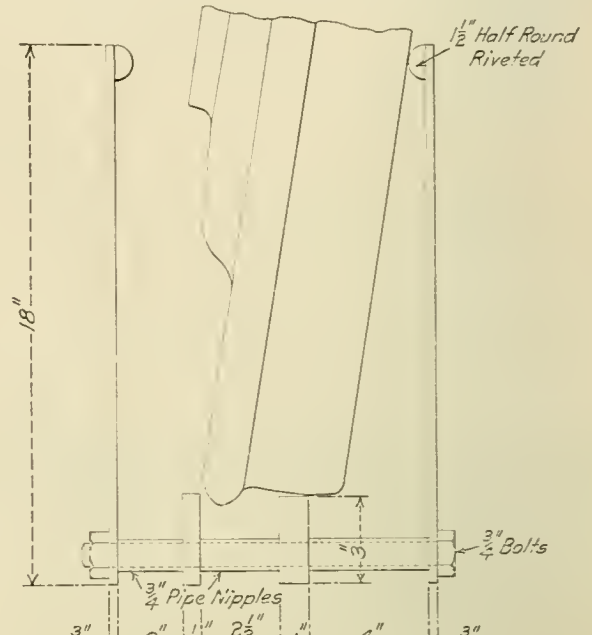

Fig. 7—Design of Chute for Scrapped Wheels

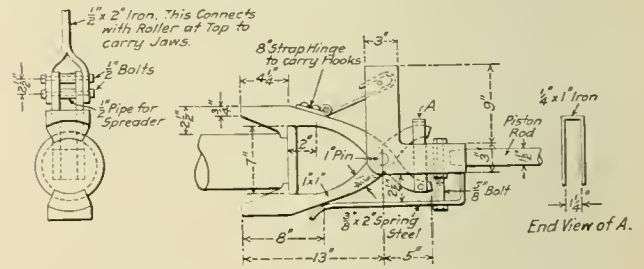

Fig. 8—Design of Hooks for Dismounting Press

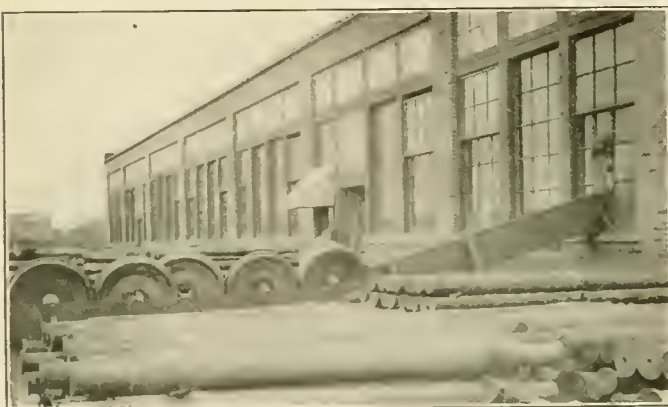

Fig. 6—Chute for Passing Scrapped Wheels out of the Shop

wheel is either stored or rolled to an awaiting car; the chute is shown in Figs. 6 and 7. The wheels that are not to be scrapped are kept in the shop to be mated and re-applied.

After one wheel is removed, the other wheel with the axle is pulled out of the press jaw a certain fixed distance, as shown in Fig. 3, by a grab hook operated by an air cylinder, the arrangement being shown more clearly in Fig. 4; a detail drawing of the grab hook is given in Fig. 9. The wheel outside of the

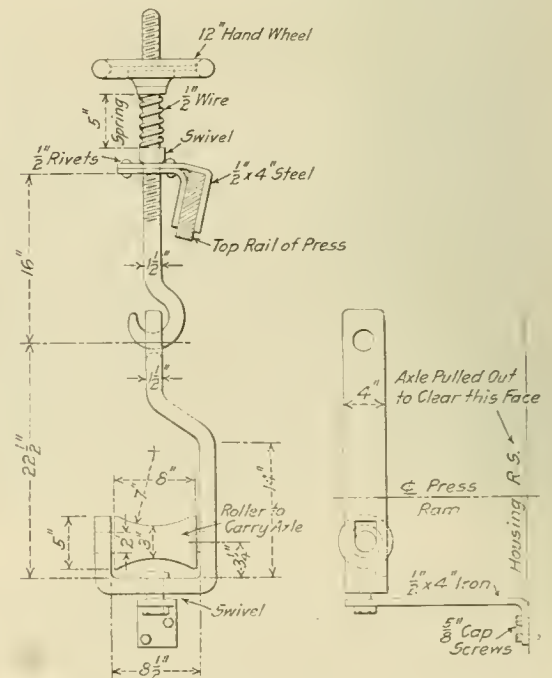

Fig. 9—Swivel Hook for Dismounting Press

this hook is shown in Figs. 3 and 4, and in detail in Fig. 9. The wheel is then rolled around, as indicated in Fig. 4, and placed

on the press so that it too may be removed. The axle is then removed and placed in the proper pile, for inspection. With this equipment one man can easily strip 11 pairs of 33 in. cast

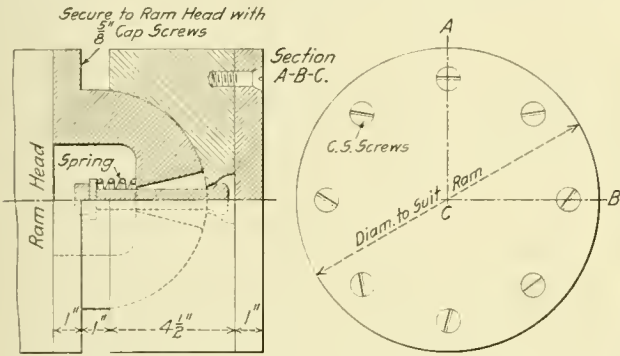

Fig. 10—Swivel Head for Dismounting Press

iron wheels an hour, properly marking and handling all the axles and reclaimed wheels.

The head of the ram of this press is fitted with a flexible head, as shown in Fig. 10. This eliminates all danger of bend-



Fig. 11—Axles Ready for Fitting

ing the journal in case it is not directly in line with the ram, due to an obstruction on the inside of the wheel preventing it from seating squarely on the jaws of the press.

After the axles are inspected and turned, if necessary, they

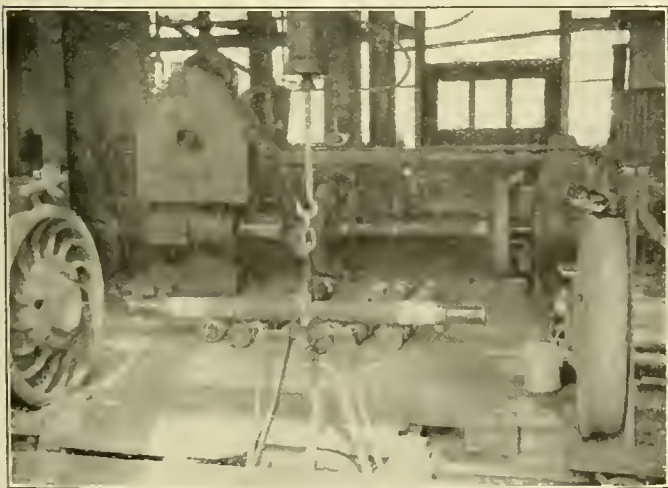

Fig. 12—Assembling and Mounting Press

are grouped for size and placed in piles, one axle high, as shown in Fig. 11, for the convenience of the wheel borer. When the wheels have been fitted to them they are taken to the mounting press shown in the background of Fig. 11, by a mono-rail crane. They are then lifted by an air hoist on a jib crane and fitted to

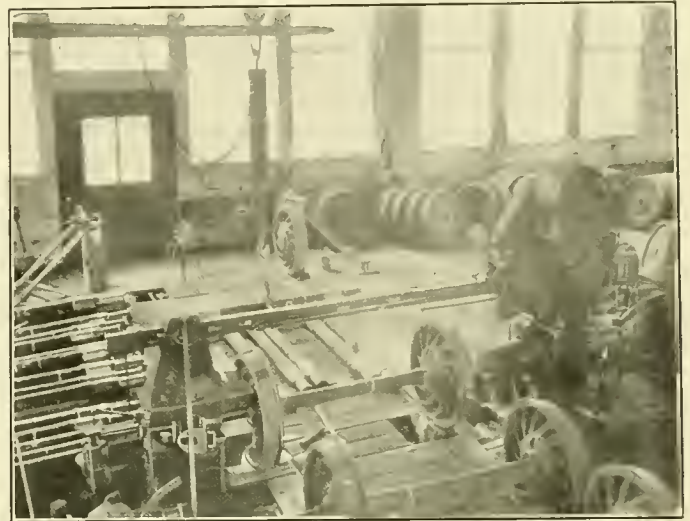

Fig. 13—Assembling and Mounting Press Looking in the Opposite Direction from Fig. 12

the wheels in an air-operated press shown in the foreground of Fig. 12 and in the background of Fig. 13. This press is made up of a rigid head and a movable head, the latter being operated by an air cylinder which is controlled by a four-way cock

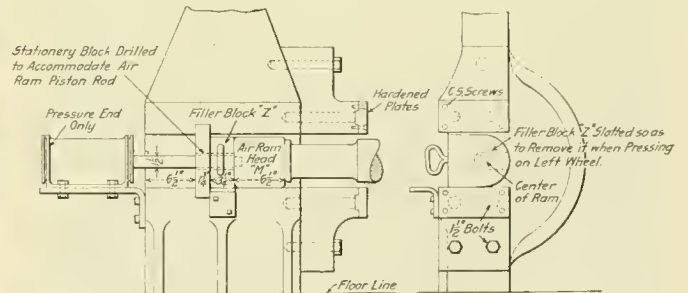

Fig. 14—Arrangement of Outboard Housing for Mounting Press

shown half way between the heads so that the operator may operate the machine and guide the axle at the same time. This press is mounted on two 5 in. I-beams and the heads or supports are made of 1/2 in. steel plate. This arrangement greatly ex-

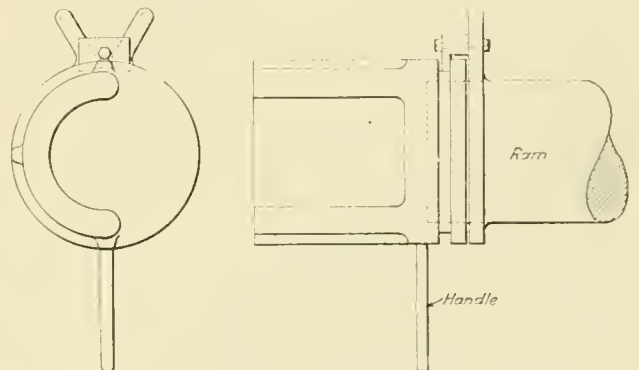

Fig. 15—Attachment for Mounting Press Ram

pedites the locating of the wheels on the axle and insures that they are started true. The space between this preliminary press and the hydraulic mounting press will accommodate five pairs



of wheels. The hydraulic press, being of an old design, is provided with special jaws fitted to the outboard housing, as shown in Fig. 14, and an offset piece, the detail of which is shown in Fig. 15, is fitted in a groove in the ram head. This offset piece bears on the wheel and is cut away to receive the end of the axle. It is also free to revolve on the ram so that after the wheels are pressed on, they can be passed on through the machine. The outboard housing is also provided with an air plunger, as shown, to push the wheels over in line with the outgoing track after they have been forced on, and to also push the axle over so that a filler block Z, Fig. 14, may be admitted, thereby lifting the near wheel off the housing when it is desired to force the other on the axle a little more. With this arrangement one, two or four men can work to advantage. One man will average 50 pairs of 33 in. cast iron wheels a day; two men, 100 pairs, and four men, 170 pairs. The hydraulic press is provided with a recording gage, whereby a complete record of the pressure used in forcing on each pair of wheels is obtained and this is kept for future reference.

The steel tired wheels are handled outside of the shop in a special fuel oil tire heater made by the Mahr Manufacturing



Fig. 16—Fuel Oil Heater Which is Placed Outside the Shop for Heating the Tires of Steel-Tired Wheels

Company, Minneapolis, Minn. This heater is shown in Fig. 16. One man handles this entire work with the aid of a jib crane and can replace one steel tire an hour, including the removal and replacing of the retaining rings, at a cost of 27 cents per wheel. The heater will remove an average of 126 worn out 40 in. tires in nine hours, and will heat 54 new 40 in. tires in the same length of time. It is lined with fire brick 4 in. thick, and the body is cast iron  $\frac{7}{8}$  in. thick; the covers are all operated by one lever. After the first tire is heated the machine lights itself from the heat of the bricks. To operate this machine, the wheel is placed in the heater and the burner lighted. When the tire expands the wheel drops through to the truck below. The truck is then pulled out and a new tire heated and placed on the wheel. A new tire can be heated and slipped over the wheel and another tire placed in the heater while the first tire is being set and another wheel made ready. This will take about six minutes and allow time for the second tire to be heated. This makes a continuous performance and enables the man in charge of the work to complete a wheel every six to seven minutes.

## INSTALLATION AND MAINTENANCE OF ELECTRIC HEADLIGHT EQUIPMENT

BY V. T. KROPIDLOWSKI

V

We now come to the conversion of the electric energy to a light producing agent. The older forms of illuminants, oil and gas flames, have met more or less successfully the rather exacting conditions and have very largely determined the type of fixtures and reflectors in use at present; but the flame lamps are at best only markers. The intrinsic brilliancy of the oil flame is very low, and the flame cannot be concentrated near the focal point of a parabolic reflector.

The electric arc is a very powerful light source of small volume, and if backed by the proper reflector produces a dazzling beam of light. The wonderful progress being made in the manufacture of incandescent lamps puts this lamp in the field as a strong rival of the arc lamp, and the writer believes that it will not be long before it will replace the arc, considering that the arc lamp is not very well adapted, as far as the regulating mechanism is concerned, to the severe conditions met on a locomotive. The advent of the tungsten filament lamp has made possible constructions with the incandescent material wound in close spirals so as to occupy a small space, within a sphere of about  $\frac{1}{4}$  in. to  $\frac{1}{2}$  in. diameter, which makes it more suited as an efficient light source in the parabolic reflector. These lamps can be furnished for the voltage now used (30 volts), but if a lower voltage could be fixed upon, a sturdier filament would be the result and with the improvements in storage batteries it should be possible to obtain conditions approaching much closer the ideal.

Figs. 1 and 2 show respectively the candle power distribution curve of a 50 c. p. incandescent lamp in a 20-in. reflector, measured at a distance of 500 ft. at the center of the beam and at intervals of one foot to one side of the center, and an isolux curve showing the distance and width of the track illuminated to 1/10 foot-candle. The distribution curve is an actual photometric measurement, but the isolux curve is calculated from the distribution curve on the assumption that the candle power varies according to the law of inverse squares. It is seen, from this approximate computation, that an incandescent lamp of as low c. p. as this is sufficient for this service. By tests made by some railroads the indications are that an intensity of from 0.05 to 0.10 foot-candle thrown on a man wearing dark clothes renders him visible at from 800 ft. to 1,000 ft. Of course the present state laws will not allow a lamp of such low candle power; 1,500 c. p. without the aid of a reflector is what a number of the states prescribe, but with the progress being made in the improvement of the incandescent lamp the manufacturers should before long have developed an incandescent lamp for headlight service which will meet the requirements of the law.

The surface used in the design and construction of the parabolic reflector is the paraboloid of revolution, a surface generated by revolving a parabola about its axis. A parabolic curve is developed from a fixed point and a fixed line. The fixed point is *O*, Fig. 3 and the fixed line, *cc*. The line *bb*, called the diameter, is perpendicular to the fixed line *cc* and is therefore at all times a horizontal line. The line *a*, called the radius, pivots about the fixed point *O*. By making the lines *a* and *b* of equal length to the point of intersection a number of points *g* will be obtained and a line drawn through these points will be the parabolic curve. It is evident, therefore, from the construction of the parabola that the two lines *a* and *b* make equal angles with a line *ce*, called the tangent, and consequently with the surface of the parabolic reflector. So, if we were able to concentrate a powerful light source at the point *O*, every ray emanating from it would be reflected in a straight horizontal line, and we would multiply the intensity of the light source as many times as there were rays; if the intrinsic brilliancy of each

ray was equal to one candle power we would have a total candle power equal to the number of rays. The beam of light composed of the reflected rays is not covered by the law of inverse squares, but in a clear non-absorbing medium will be projected to infinity without increase or decrease of intensity; that is, if theoretically perfect conditions could exist, which is impossible.

We cannot concentrate a practical light source so that it will lie wholly within the ideal focal point, a dot; some of it must of necessity be without the focal point, and these rays emanat-

of light  $f$  emanating from the surface of the light source that lies in front of the focal point, we no longer have the true condition upon which the parabolic curve is based. The radius  $f$  is no longer equal in length to the diameter  $b$ , and consequently the tangent  $ee$  is tipped on its point  $g$  slightly to the left; as a result the line  $b$  will not be parallel to the axis but will reflect in the direction of the line  $h$ . The fact that commercial light sources depart widely from the theoretical point sources, and that we can only approximate the theoretical conditions in prac-

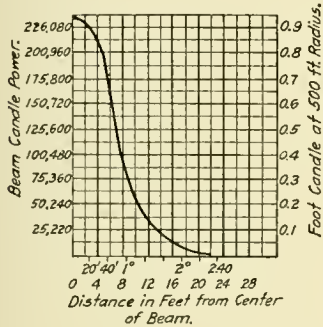

Fig. 1.

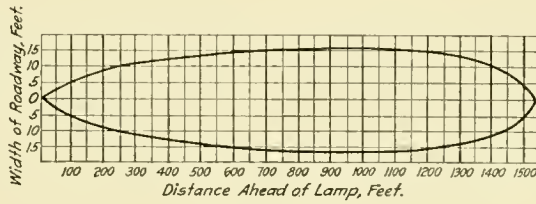

Fig. 2-Isolux Curve.

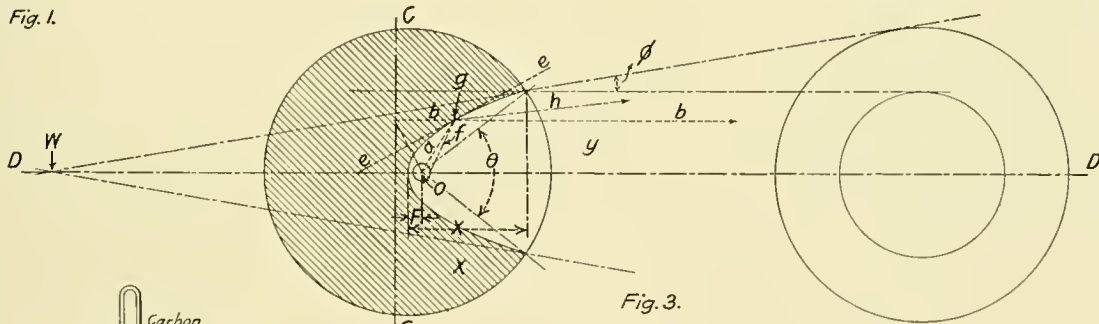

Fig. 3.

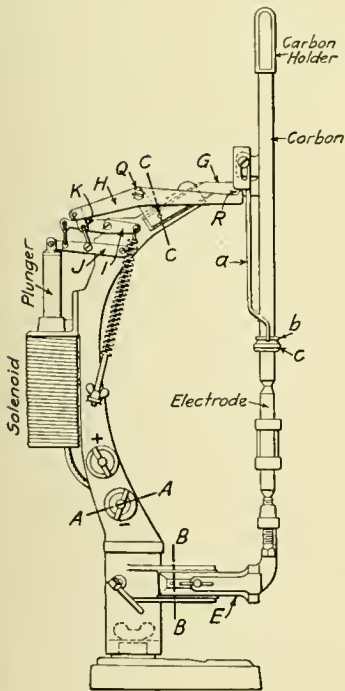

Fig. 4.

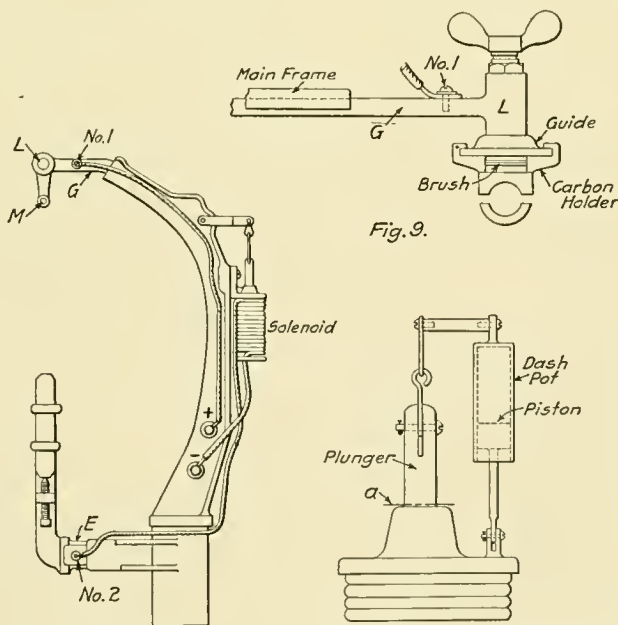

Fig. 5.

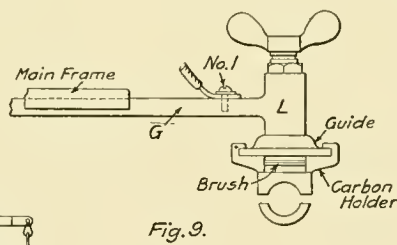

Fig. 9.

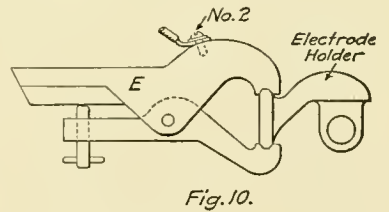

Fig. 10.

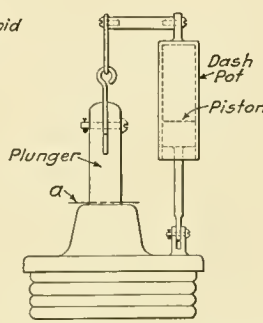

Fig. 11.

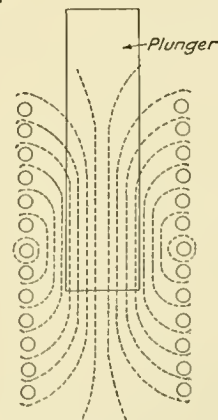

Fig. 12.

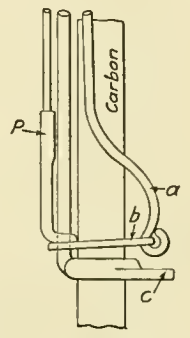

Fig. 13.

Candle Power Diagrams and Arrangement of Electrodes, etc., in Electric Headlights

ing from the surface that lies without the focal point will not be projected in parallel rays, but will diverge or converge according to whether they come from the surface ahead of the focal point or from behind it. The reason that the rays outside of the focal point are not projected parallel to the axis of the parabola is that in the case of a polished reflector that law governs which states that the angle of reflection equals the angle of incidence. By again referring to Fig. 3, if we consider a ray

causes no ill effect in the case of a locomotive headlight; in fact, it is a benefit, as if all the rays were projected parallel to the axis and all coincided, the area illuminated by the beam would be a circle equal in diameter to the reflector, which would not be suitable for illuminating the space ahead to any practical advantage. What is required is a beam that will spread enough to illuminate the road at least fifteen feet to each side of the center. The spread of the beam is governed by the ratio of the



focal length to the diameter of the reflector and must be determined upon in the design. Emphasis is here placed on the necessity of focusing the lamp properly, for the beam candle power depends on this more than on anything else; moreover, if the lamp is not properly focused, shadows will appear in the beam. Of course shadows will sometimes be present even though the lamp is accurately focused, but they are due to defects in the reflector, such as dents, rough surfaces, etc.

Let us assume now a concrete case and apply the above conclusions to it, maintaining ideal conditions. Referring once more to Fig. 3, take  $y = 9$  in. and  $x = 13$  in.; the focal length  $F$  will be in this case  $1\frac{1}{2}$  in. and the area of the beam will be 1.75 sq. ft. A uniform source of one candle power placed at the center of a sphere of one foot radius illuminates every point on the interior of the sphere to the intensity of one foot-candle. The area of the surface of the sphere is 12.57 sq. ft., hence, the total quantity of light given off by a source of one candle power illuminates an area of 12.57 sq. ft. to an intensity of one foot-candle. The term lumen is used to denote the quantity of light received on each square foot of surface; thus a light source of one spherical candle power will produce an intensity of one foot-candle over 12.57 sq. ft., or 12.57 lumens.

There will be a cone of light as shown by  $\theta$  which will not be under the influence of the reflector and will be subject to the law of inverse squares, and which when subtracted from the area of the whole sphere leaves us 11.43 sq. ft. An ordinary arc lamp using copper for the negative electrode produces about 1,300 mean spherical candle power; the total light flux will then be 1,486 lumens, which divided by the area of the mouth of the reflector, 1.75, gives an average of 8,490 lumens per square foot on the cross section of the beam of light. At a distance of one foot from the source the candle power of a lamp at the same point would be 3,919, and at 100 ft., according to the law of inverse squares, and on the assumption that the intensity of a reflected beam does not decrease, it would be equal to a lamp placed at the door of the reflector and equal to  $100 \times 100 = 10,000$  times 8,490 = 84,900,000 c. p.

In the case of a divergent ray, if we assume  $\Phi$  equal to one degree, the sine of which is .0175, we can calculate the field that will be illuminated at any distance; for instance, at 1,000 ft. the field illuminated will be  $0.0175 \times 1,000 = 17.5 \times 2 = 35$  ft. in diameter. The divergent ray projected backward will cross the line  $DD$  at  $H'$ , approximately 44 ft. from the front of the reflector. The average illumination at the front of the reflector will be the same as for the parallel ray, as we are not changing any physical details but merely mathematical; to produce this illumination with an unreflected light source at  $H'$  will require a lamp of  $44 \times 44 \times 3,919 = 16,436,640$  c. p. The illumination at any other point in front of the reflector may be computed by the law of inverse squares by using this value and referring to the point  $H'$  as an origin. We can then refer to the lamp as equivalent to a 16,436,640 c. p. source. If we use an incandescent lamp of 100 candle power in place of the arc lamp, we will obtain  $11.43 \times 100 = 1,143 \div 1.75 = 653$  lumens per square foot, and an equivalent candle power at  $H'$  of  $44 \times 44 \times 67 = 1,250,290$ .

We can now calculate the approximate illumination of the road ahead of the locomotive. At 5,000 ft. the arc lamp will give  $16,436,640 \div (5,000 \times 5,000) = .65$  foot candles at the center of the beam and at  $1/10$  foot-candle at that distance  $.65 \div 0.1 = 6.5$ ; the square root of 6.5 = 2.56, the distance in feet which will be illuminated at the side of the road bed. With the incandescent lamp, at 1,500 ft. ahead we obtain  $1,250,290 \div (1,500 \times 1,500) = 0.54$  foot-candles at the center of the beam and at  $2.3$  ft. to one side of the road  $1/10$  foot-candle. By a continuation of this process we can obtain any number of points along the illuminated way.

The principle of operation of the ordinary direct current arc lamp is as follows: The current from the positive brush of the dynamo comes by the way of the + binding post, Figs. 4 and 5,

(Fig. 4 shows one side of the arc lamp and Fig. 5 the opposite side, Fig. 5 showing the connections plainer), and follows the wire to connection No. 1, through the bracket  $G$ , which is fastened at  $L$  and  $M$  to the guide which is not visible back of the carbon, and in Fig. 4 it enters the guide where it is picked up by a small brush that is fastened to the carbon holder and passes through the carbon holder into the carbon. The carbon and electrode being in contact, the current continues on through the electrode, through the small frame that supports the electrode to the bracket  $E$ , through the connection No. 2 on the bracket  $E$ , shown plainer in Fig. 5, following the wire, which leads it into the winding of the solenoid at the upper end, through the solenoid winding and out at the bottom to the negative binding post; thence it returns to the dynamo. As soon as current passes through the solenoid it energizes it and creates a magnetic flux in its hollow center, in which the plunger is suspended. The magnetic flux tries to equalize itself through this iron plunger and thereby pulls the plunger down. The plunger being connected to lever  $J$  pulls this lever down with it, and lever  $H$  being connected with lever  $J$  also is pulled down;  $H$  being pivoted at  $Q$ , this movement causes the end at  $R$  to rise, which lifts rod  $a$ , which in turn tips the clutch  $b$  until it clamps the carbon and lifts it along with it. When the carbon is lifted the contact is broken between it and the electrode and the current trying to continue on its course establishes the arc; of course the carbons are separated just enough so that the voltage available at the arc is able to continue forcing current through the air gap, and as the upper carbon burns off the air gap becomes greater, the voltage not being able to maintain current through the widened gap, the solenoid loses its energy and allows the upper carbon to drop; the latter comes in contact with the electrode again and current starts flowing anew, repeating the operation.

The insulation is of prime importance and misunderstanding or negligence may cause much damage and expense. The operator as well as the attendant should be sure whenever it becomes necessary for any reason to disturb any of the insulators, to see that they are put back properly. Cases are not lacking where lamps have been burned out due to just such negligence. If the + and - binding posts were not insulated from the main frame a dead short circuit would exist, and if something does not give way at the arc lamp to break the current's path, the dynamo winding will burn out; this would also happen in case any two opposite polarity insulators were left out. For this reason the writer has made it a point to bring out all the places of insulation in the detail drawings. Fig. 6 is a section taken through binding post and frame on the line  $aa$ , Fig. 4; the insulation denoted by the word fiber to which arrows point is shown by cross lines and the other members of the detail are not cross hatched in order to bring out the insulation clearly. Fig. 7 is a section taken on the line  $cc$ , where the small bracket  $G$  is fastened to the main frame. Fig. 8 is a section taken on the line  $bb$ , where the lower bracket  $E$  is attached to the main frame. The importance of insulating these two brackets from the main frame will be seen, as if they were not insulated there would be nothing to prevent a short circuit, and the current would not go through the carbons to create an arc but would pass through no resistance, but through the main frame directly to the generator. But one make of lamp is illustrated for the reason that the principles of operation are the same, only they vary somewhat in detail.

Figs. 9 and 10 show respectively, in larger detail, the upper bracket  $G$  and the lower bracket  $E$ ; these drawings are self-explanatory. The numerals and letters that are the same in the different figures represent the same parts.

Fig. 11 shows the dash pot, which is a small cylinder with a piston. Its function is to steady the action of the solenoid plunger. If this dash pot were not there, the plunger would be pulled in with a jerk, probably beyond the equalization zone of the magnetic flux, and a seesawing would take place resulting

in a make-and-break arc. The dash pot should be removed occasionally and the cylinder wiped out, but no oil should be used to lubricate it, as oil will gum and cause the arc to jump, and will get under the seat of the little ball valve. If the cylinder shows considerable wear by evidence of the piston being loose, it should be renewed. The suction in the cylinder is regulated by a little ball valve in the piston; this should be kept in good working order.

Fig. 13 shows the clutch that lifts the carbon; *C* is the rigid frame support and also a guide for the carbon and *a* is the lifting rod attached to the clutch *b*. The clutch is horseshoe shaped with an opening large enough for the carbon to work freely in it. The upper end of the rod *P* works in a socket having a coil spring, and when the rod *a* pulls up, the rod *P* pushes down on the heel of the clutch, which action sets the clutch on an incline and thereby grips the carbon and lifts it. The tension of the spring in the socket that pushes down the rod *P* can be regulated, so that in case the clutch does not grip the carbon early enough in the stroke the tension of the spring can be increased, causing more pressure on the rod *P* so that it will trip the heel of the clutch earlier in the stroke and cause the clutch to grip the carbon and raise it before the plunger gets down too low in the core of the solenoid.

The spring shown in Fig 4 is also there for the purpose of steadying the movement of the plunger, but acts mainly as a counterweight for the upper carbon and the levers. It can also be regulated to suit conditions. The link *K*, Fig 4, is also a very important detail, as it is of fiber and is an insulator as a second precaution between the positive and negative sides of the wiring. Care should be taken not to replace this link with a metal one.

The principle of the operation of the solenoid and the plunger is shown in Fig 12. The dotted lines represent the lines of magnetism that are created by the current passing through the winding, which is represented by the small circles. It will be noticed that the lines of magnetism are most numerous at the middle of the length of the solenoid, which explains the pulling in of the plunger. The pull is greatest before the plunger reaches over the middle point, and when the lower end is flush, or very nearly so, with the lower end of the solenoid, there will be no pull, as then an equalization takes place and there is just as much pull up as there is down. In case the momentum created by the sudden pull brings the plunger beyond the equalization point, as mentioned earlier in the article, there will be a sudden pull upward again, for the reason that the plunger has passed over the middle point; this is what causes the jumping and seesawing mentioned before. The regulating springs, etc., are provided to cause the plunger to separate the carbons before arrival at this unsteady point.

There is a difference between the copper electrode's burning, being consumed, and melting. If it is being consumed, which is evidenced by the tip becoming dull and short, the voltage is too high, which may be remedied by reducing the speed of the turbine. If the copper is found to be melted, the voltage is too low or the regulating mechanism is defective. To remedy this, light the lamp and let it burn a short time, scribe a line on the solenoid plunger, having previously chalked it so the line will be visible, as at *a*, Fig. 11. Cut off the current, allow the carbons to cool and pull down the plunger till the line is even with the base of the solenoid, which will bring the carbons to the same position they were in when the plunger was marked. Now measure the distance between the carbons, and if it is found that they are not 1/16 in. apart, lengthen the spring that operates the lever *P*, Fig. 13, or shorten the link that connects the plunger to the lever *J*, Fig. 4. Light the lamp again and mark the plunger the same as before, cut off the current and measure the distance the electrodes are now separated, and if still less than 1/16 in., bend up the end *R* of lever *H* until the proper distance is obtained between the electrodes. Numerous cases have come to the

writer's attention in which the wrong end of the equipment was being treated for the trouble, that is, instead of adjusting the lamp for fused coppers, the speed of the generator was reduced and, as a consequence, the trouble was augmented, as low voltage will also fuse the copper.

The copper electrode fuses because the arc is too short and does not allow the lava from the crater of the carbon electrode to remain and protect the tip of the copper from the intense heat of the positive pole or upper carbon.

If the lamp will not burn when the locomotive is running but burns when it is standing, the trouble is with the clutch *b*, Fig. 13. It is usually worn oblong or the edges are worn round. In this case the clutch should be renewed. The reason the lamp does not burn when the engine is running is because the clutch will not grip the carbon sufficiently to prevent the jarring of the locomotive from shaking the upper carbon down on the lower one. This must be remedied at once, for when the carbons touch when the generator is working and the lamp is cut in they permit a short circuit, overheating and warping the regulating mechanism and probably burning out the armature winding of the generator.

## REMOVING FRONT TUBE SHEETS

BY PAUL R. DUFFEY

The removal of a damaged or badly worn front tube sheet from a locomotive boiler is, with the best known methods, a long and tedious operation. The method here described is one that has proved to be more satisfactory than some the writer has seen used, and is the practice at the Norfolk & Western shops at Portsmouth, Ohio.

A piece about 4 or 5 in. long is cut out of one side of the smoke box stiffening ring. This piece is taken out on the horizontal center line of the smoke box and extends an equal distance above and below the line. A piece of the same length is then cut out to one-half the depth of the smoke box division

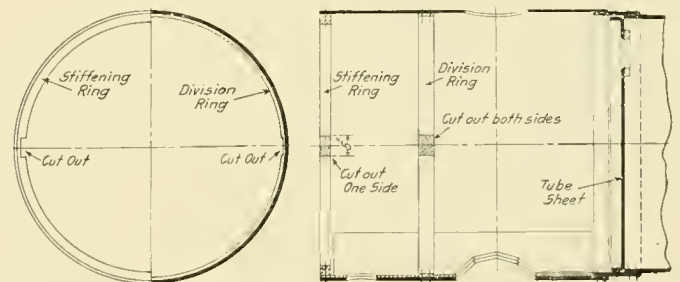

Method of Cutting Rings to Remove a Front Tube Sheet

ring, on both sides of the smoke box and on the same horizontal center line as before. After all the rivets and braces have been removed from the tube sheet, it is pulled over to a horizontal position and removed from the front end through these slots. It has been found that after the new sheet is put in place it is not necessary to set a piece in the division ring, as it is not materially weakened. A piece is fitted and riveted in the stiffening ring, holes being provided for holding the front in place. The time required to do this work under ordinary conditions is from 12 to 15 hours.

CAPE TO CAIRO RAILWAY.—The Cape to Cairo Railway is now at Kambove, 800 miles beyond the Victoria Falls and 300 miles inside the Congo border. A further extension of 100 miles to Burame is about to be commenced. Within a brief period there will be communication from the mouth of the Congo at Boma right across Africa to Dar-es-Salaam.



## ABRASIVE WHEELS

BY C. J. MORRISON

A frequent sight in machine shops is an abrasive wheel worn down too far below its useful size and running at so slow a speed that grinding is almost impossible. Such a wheel is the acme of false economy, as it not only wastes productive time every day, the value of which is far in excess of the price of a new wheel, but entails other losses due to poorly ground tools. Even though it may be possible to properly dress a tool on such a wheel—usually it is not possible—the average mechanic has not the necessary patience.

Another source of loss is from wheels of improper grain or grade, or both, for the work. This loss is not so easy to detect, but is fully as prevalent as the first.

Still another frequent sight is two wheels of different diameters mounted on one spindle and neither running at the proper speed. Of course, it is impossible to run both at the right speed.

Losses due to improperly dressed wheels are due to pure neglect and need not be considered. The other troubles usually come from the fact that no one is particularly interested in the wheels, or, if interested, has neither the time nor the knowledge necessary to attend to them.

The purchasing agent is usually interested in having the wheels last a long time, and orders frequently stipulate that the wheels must be harder than the last shipment as they wore out too soon. Also orders often simply call for one wheel of a certain size, and no specifications as to grain, grade, or use are given.

In order to produce economies and to secure the desired results, the grinding problem must be intelligently studied. Proper grinding is nothing more or less than cutting, and one wheel is no more fitted for all kinds of grinding than one tool is capable of all kinds of cutting. A wheel that will grind high speed steel tools is almost useless for brass.

Few can devote sufficient time to the subject to become experts on abrasive wheels, but almost any one can become sufficiently posted on the basic essentials to be able to intelligently select, install and maintain the wheels.

The grain of a wheel is represented by a number which refers to the mesh of the screen through which the grain will pass when in the dry state. Consequently, the higher the number, the finer the grain. Grade refers to the quality of the abrasive as to whether it is hard or soft, and the different grades are represented by letters, the first letters of the alphabet representing the softest and the abrasive becoming harder as the letters progress. As an example, 30-0 represents a grain which would pass through a 30-mesh screen and a medium grade. In large wheels this is adapted to the grinding of medium high speed steel tools.

Unfortunately, the grading is not exactly the same with different makes of abrasive wheels so that a combination which is satisfactory in one make may not be as efficient in some other case. However, the following specifications may be used as a guide:

Class of Work.	No. of grain or degree of coarseness usually furnished.	Grade letters or degrees of hardness usually furnished.
Large cast iron and steel castings.....	16 to 20	P to Q
Small cast iron and steel castings.....	20 to 36	P to Q
Large malleable iron castings.....	16 to 20	Q to R
Small malleable iron castings.....	20 to 30	P to Q
Chilled iron castings.....	16 to 20	R to T
Wrought iron.....	16 to 30	O to P
Brass and bronze castings.....	20 to 30	P to R
Rough work in general.....	16 to 30	P to Q
General machine shop use.....	30 to 46	O to P
Lathe and planer tools.....	30 to 46	N to O
Small tools.....	46 to 100	N to P
Wood-working tools.....	36 to 60	M to N
Twist drills (hand grinding).....	36 to 60	M to N
Twist drills (special machines).....	46 to 60	J to M
Reamers, taps, milling cutters, etc. (hand grinding).....	46 to 100	N to P
Reamers, taps, milling cutters, etc. (special machines).....	46 to 60	H to Q
Drop forgings.....	20 to 30	P to K
Gumming and sharpening saws.....	36 to 60	M to N
Planing mill knives.....	30 to 46	J to K
Car wheel grinding.....	20 to 30	O to P

After selecting a wheel according to this table, its service should be carefully watched and alterations made in the grain and grade until exactly the right results are obtained. In general, if the wheel glazes, it is too hard, while if it wears away too rapidly, it is too soft. Also if the wheel has a tendency to burn the work, it is of too fine a grain. The manufacturers should be consulted and their co-operation obtained in the selection of wheels. After the proper specifications have been secured for each class of grinding, they should be made standard and wheels ordered accordingly instead of to suit the whims of workmen or foremen.

All grinding should either be done dry or with a copious stream of water. Nothing is more dangerous to the success of grinding than an inadequate or intermittent supply of water.

Assuming proper grain and grade to have been selected, the efficiency of grinding is directly proportional to the peripheral speed of the wheels. The manufacturers test wheels at a peripheral speed of 9,000 ft. a minute or over, and in practice they should be run between 5,000 and 6,000 ft. a minute. It is profitable to arrange so that wheels will make 6,000 ft. when full size, as by such an arrangement they can decrease considerably in diameter before becoming too inefficient to be profitable. The following table of peripheral speeds for different diameter wheels will be found useful:

Diam. of wheel. Inches.	Revolutions per minute for peripheral speeds.		
	4,000 ft.	5,000 ft.	6,000 ft.
1.....	15,279	19,099	22,918
2.....	7,639	9,549	11,459
3.....	5,093	6,366	7,639
4.....	3,820	4,775	5,730
5.....	3,056	3,820	4,584
6.....	2,546	3,183	3,820
7.....	2,183	2,728	3,274
8.....	1,910	2,387	2,865
10.....	1,528	1,910	2,292
12.....	1,273	1,592	1,910
14.....	1,091	1,364	1,637
16.....	955	1,194	1,432
18.....	849	1,061	1,273
20.....	764	955	1,146
22.....	694	868	1,042
24.....	637	796	955
30.....	509	637	764
36.....	424	531	637

Many grinding machines have entirely too few speeds. In fact, a large number have only one speed. The lack of proper speeds means decreased efficiency and should be avoided in the purchase of new machines. Sometimes where more than one machine use the same wheels they can be run at different speeds, and a wheel first used in a fast machine then transferred to a slower one. Each machine should be provided with instructions concerning the speeds for different diameter wheels. These ideas can very profitably be applied to the wheels supplied for general use in the shop.

One large shop has a number of grinders with two speeds and others with one speed, all using the same wheels. Signs mounted on the stands in plain sight tell when the belt is to be shifted to the faster speed, and when the wheel is to be removed and placed in the single speed machine, which is revolving even more rapidly. Signs on the latter tell when the wheel is to be finally scrapped. Incidentally a locked flange device prevents the wheels being run at the high speeds when they are of too large a diameter.

Stands for the wheels should be of very heavy, rigid construction, and should be firmly secured to good foundations. In cases where they must be placed on floors, large bases should be provided, and these should be fastened to the floor supports, not to the floor itself.

After all other conditions have been met, the final success and safety of grinding depend on the mounting of the wheels. Wheels should be mounted on spindles of ample size, between sufficiently large and heavy flanges, so concaved that they bear against the wheels at their outer edges only. Many wheels are labeled with pads of pulp or blotting paper which form a cushion for the flanges, and in addition to this it is desirable to use rubber or

leather washers a trifle larger than the diameter of the flanges.

Never crowd a grinding wheel upon an arbor. Don't mount it unless it is found to be an easy fit. Flanges should be at least one-third the diameter of the wheel, and one-half is recommended; always concaved, never straight or convex. Never mount wheels without flanges. To some this warning may seem unnecessary, but wheels are frequently found simply held by a small nut which is liable to crawl, and when forced in at the center will break the wheel.

If rests are used, they should be in good order, rigidly secured, and kept as close to the wheel as possible.

Keep the boxes well oiled so that the arbor will not become heated, thus causing expansion and possible breakage.

Wherever possible, cover the wheels with hoods of heavy flange steel.

As a final precaution and to insure efficient grinding, have some one definitely responsible for the wheels, their maintenance and use.

## A PLANT FOR RECLAIMING ASBESTOS BOILER LAGGING

BY ALDEN B. LAWSON

In these times when every department head must economize as far as possible, we find experiments being made with a view to utilizing scrap material. One of these which has proved a success is a boiler lagging reclaiming plant. Previous to the inauguration of this plant, the scrap boiler lagging was thrown away as useless. The plant was installed at a cost not over \$800, and is merely a lean-to against one of the larger buildings. It is covered with sheet iron and has a floor 18 ft. by 40 ft., this size answering the purpose for shops that have an output of from 60 to 70 locomotives per month.

On locomotives coming into the shop for repairs, from 20 to

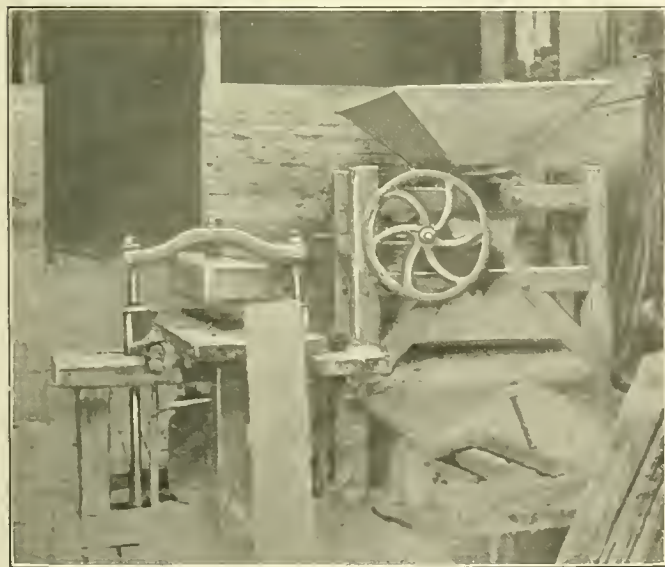

Fig. 1—Grinding and Picking Machine, Air Press and a Completed Sheet of Lagging

25 per cent. of the lagging is broken in removing it from the boilers and in handling. While previously this would have been a complete loss, it is now ground, recast into blocks and put back in service at a very small cost compared with that of new material, with which it compares favorably in service results.

The plant consists of a storage bin for the old broken lagging; a homemade grinding and picking machine; a mixing vat about 4 ft. by 6 ft. by 12 in. deep; and a drying oven.

The grinding and picking machine is made as shown in Fig. 1.

There is a wooden hopper on top into which the broken lagging is shoveled, after having been broken into pieces about 4 in. by 4 in. This hopper will hold about 1½ bushels; at the bottom is a breaker consisting of a cast or forged thimble, bored and keyed to a shaft and having six breakers or knives made integral with the body and projecting ½ in. above the outside circumference. This is shown in Fig. 2. The breaker revolves and bites or breaks the lagging as it wedges itself between the edges

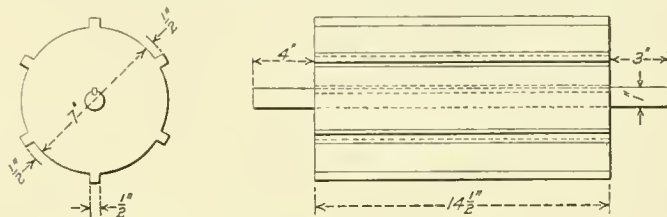

Fig. 2—Breaker for Boiler Lagging Plant

of the hopper and those of the breaker knives. The lower edge of the hopper is faced with iron and the edge next the breaker is turned up to prevent the lagging from falling through; it is set close enough to the knives to insure the lagging being broken into slender strips when it falls through to the lower box on the picker.

The picker is shown in Fig. 3 and is operated by a shaft which

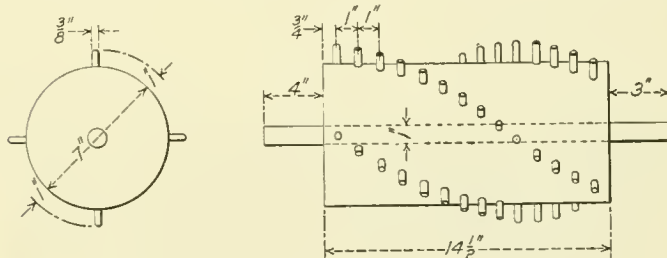

Fig. 3—Picker Used in Reclaiming Boiler Lagging

is geared to the breaker shaft. The speed of the breaker is 90 revolutions per minute, while 180 revolutions per minute is the speed of the picker. The picker is also made something like a thimble; it is bored and keyed to the shaft and the outer surface is filled with teeth about 3/8 in. in diameter and placed spirally. They extend about 1 in. above the surface and pass through slots in the toe plate which is secured to the side of

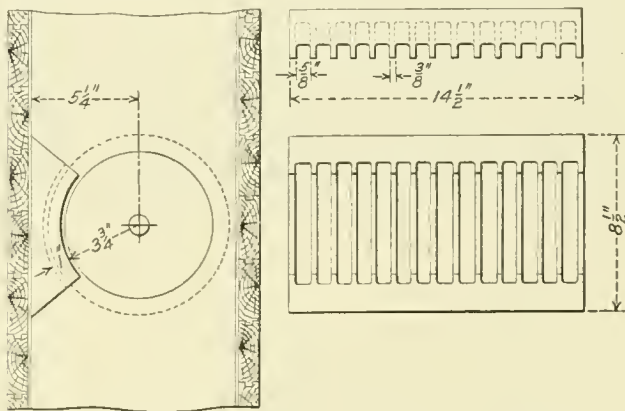

Fig. 4—Toe Plate Showing the Picker in Position

the compartment as shown in Fig. 4. The lagging strips are thus picked apart and fall through to the lower compartment which has an inclined surface to direct the material to the mixing vat. The machine is operated by air, it being the most convenient in this instance.

Another type of breaking machine may be made by the use of



a tumbling barrel made of wire netting of  $2\frac{1}{2}$  mesh. This is constructed along the lines of a flue or casting rattler, care being taken to bind the barrel sufficiently with iron strips to insure strength. A hinged opening should be provided for loading. In this barrel with the lagging are placed several pieces of scrap iron about the size and weight of a side rod knuckle pin. These crush and disintegrate the lagging and it sieves through the netting. This type of machine should be tightly boxed up to prevent dust flying and also to prevent the scattering and loss of the lagging. From 40 to 50 revolutions per minute should be sufficient speed to operate the barrel.

After the breaking and disintegrating the material is ready for

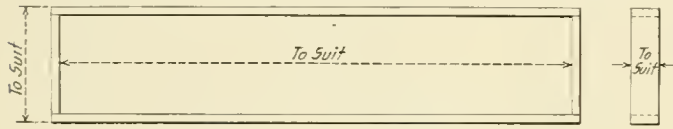

Fig. 5—Mold for Forming the Lagging into Sheets

mixing, and if separated by a machine of the first type it will not require any binder. Where the material has been broken very fine, however, it will be found that a binder is necessary, and from 8 to 10 per cent. of asbestos cement will serve the purpose. This costs about four cents a pound and will not increase the cost of the work materially. Old hemp rope is also suitable if cut in pieces from 4 to 6 in. long and mixed with the ground lagging.

Sufficient water is added to permit the mixing of the material to a doughy mass, not too thin. After a thorough mixing it is poured in the wooden molds, Fig. 5, these being made any size

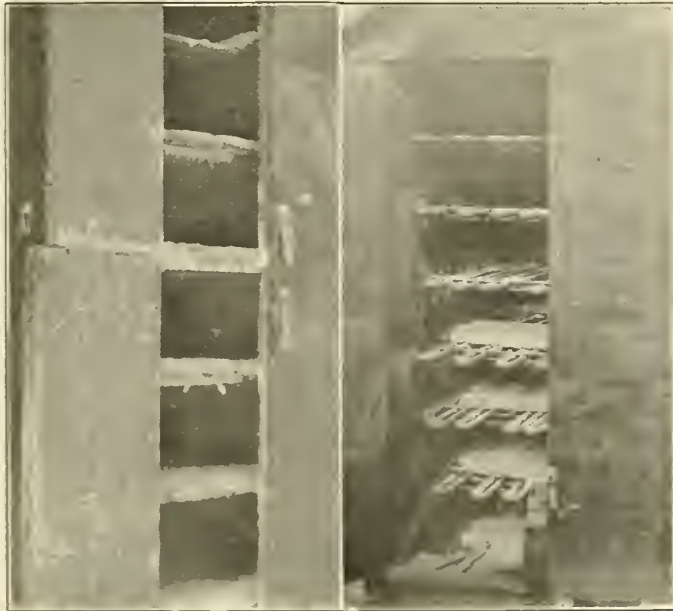

Fig. 6—Arrangement of Doors on the Inner Wall of the Oven

Fig. 7—Lagging Resting on Pipe Shelves in the Oven

desired. The mold is a smooth wooden frame, open top and bottom as shown in the illustration. It is set on a loose board and enough of the mixture is shoveled in to form the sheet or block to be cast; a sheet iron cover is then placed on top and the whole is placed in position on a table under the air press which forms the sheet and forces out all surplus material. The press is then raised, the sheet iron cover and mold removed and the operator smooths out any rough places in the sheet with a hand trowel; the base board with the sheet on it is then placed in the oven to dry, a process which requires about 24 hours. When removed from the oven the sheets are ready for use; one of the finished sheets is shown in Fig. 1, standing against the air press.

The size of this is 2 in. by  $7\frac{1}{2}$  in. by 37 in. The cost of the labor for making a sheet is  $2\frac{1}{2}$  cents; to this should be added the cost of the binder. Considering all expenses, the cost per sheet should not exceed five cents, while the cost of a sheet of new material would be about 23 cents, making a saving of 18 cents a sheet. If one pound of asbestos cement were used for each sheet at a cost of four cents, the saving per sheet would still be 14 cents, but the cement is not often necessary. One man can make 110 sheets a day, which means a daily saving of \$19.80, or about \$6,000 a year.

There should be plenty of space allowed in the oven for drying the sheets. The oven can be placed against the outside wall of a building, but should be of double sheet metal and a space of 2 in. should be allowed between the walls. This space should be packed with ground asbestos and this also applies to the inner wall of the oven where the doors open to the inside of the plant as shown in Fig. 6. The doors should be lined with asbestos and fit closely. The depth of the oven should be at least 4 in. more than the longest sheet of lagging used. The shelves are formed of six or eight lines of  $1\frac{1}{2}$  in. steam pipe, and are built like a pipe radiator but placed horizontally; these shelves should be about 15 in. apart. The lower door should control as many shelves as a man can conveniently reach for placing the lagging sheets. If floor space is available all the shelves should be within reach from the floor so as not to necessitate the use of a ladder. In the case of the oven shown in Fig. 7, it is necessary to use a ladder to reach the upper shelves because of the lack of space. This illustration also shows the ends of the shelves with lagging sheets resting on them.

This work may be handled by an ordinary laborer. It would seem best to have such plants located at the main terminals only and have the smaller stations ship their old material in barrel lots to the point of location of the plant. In this way fewer plants would be needed and the operators, by working continuously would become more proficient and obtain better results.

## JIG FOR GRINDING IN ROTARY VALVES ON E-T EQUIPMENT

BY F. W. BENTLEY, Jr.

Machinist, Butler Shops, Chicago & North Western, Milwaukee, Wis.

The absence of guide stems on the rotary valves of both brake valves of the Westinghouse E-T equipment sometimes makes it a difficult matter to hold the valves over the seat during the grinding operation. This is often the cause of annoyance and delay to work where it is only necessary to slightly grind the outer edge of the valve when it is reported by an engineman as handling hard.

Wooden guide rings which drop closely over the raised portion of the rotary valve seat, but rise slightly above it, may be used to hold and guide the valve as it is rotated on the seat during the grinding operation. These rings are made of oak. That for use on the H-6 automatic valve is  $4\frac{11}{16}$  in. outside diameter,  $3\frac{3}{16}$  in. inside diameter and  $\frac{7}{8}$  in. thick; the ring for use on the H-6 independent valve is  $3\frac{1}{16}$  in. outside diameter,  $2\frac{1}{16}$  in. inside diameter and  $\frac{7}{16}$  in. thick.

The rings are lifted quickly from around the seat when it becomes necessary to wipe it for a dry polish with the valve. In connection with such work on brake valves in both the back shop and the roundhouse, these jigs have proved of great assistance in obtaining rapid and satisfactory results.

**NARROW GAGE DINING CAR.**—The South African Railways have recently put in traffic on the Kalabas Kraal-Hoetjes Bay line, which is a 2-ft. narrow gage line, a dining car service. The car is a converted guard's van, which seats eight persons, and has been fitted up according to the suggestions of the catering manager.

# NEW DEVICES

## THE YOUNG VALVE GEAR

O. W. Young of Schenectady, N. Y., has designed a valve gear for locomotives which has a number of improved features when compared with the Walschaert design. It is actuated entirely by connections to the crossheads and is arranged to give a movement to the valve which materially increases the amount of the port opening for both admission and exhaust, and allows a 14-in. diameter piston valve to handle as large a volume of steam as a 20-in. diameter valve would with the ordinary design of Walschaert gear. It also simplifies the construction, allows easy standardization, and materially reduces the weight of the whole gear.

As will be seen by reference to the illustration, the com-

is such that when one radius bar is lowered the other is raised. This balances the two gears for reversing, without the use of a counterbalance spring. The radius rod and the connection from the top of the combination lever both join a short link, the end of which is connected directly to the valve stem cross-head.

The link, combination lever and reverse bell crank have a common fulcrum on either side and the bearings for both of the shafts extending across the locomotive are contained in the same casting which is supported by a frame cross-tie.

A number of ellipses have been made with this gear on the valve gear model at the Schenectady plant of the American Locomotive Company. The model was arranged for a valve travel of  $8\frac{1}{2}$  in., which was secured with a 42 deg. angle of the

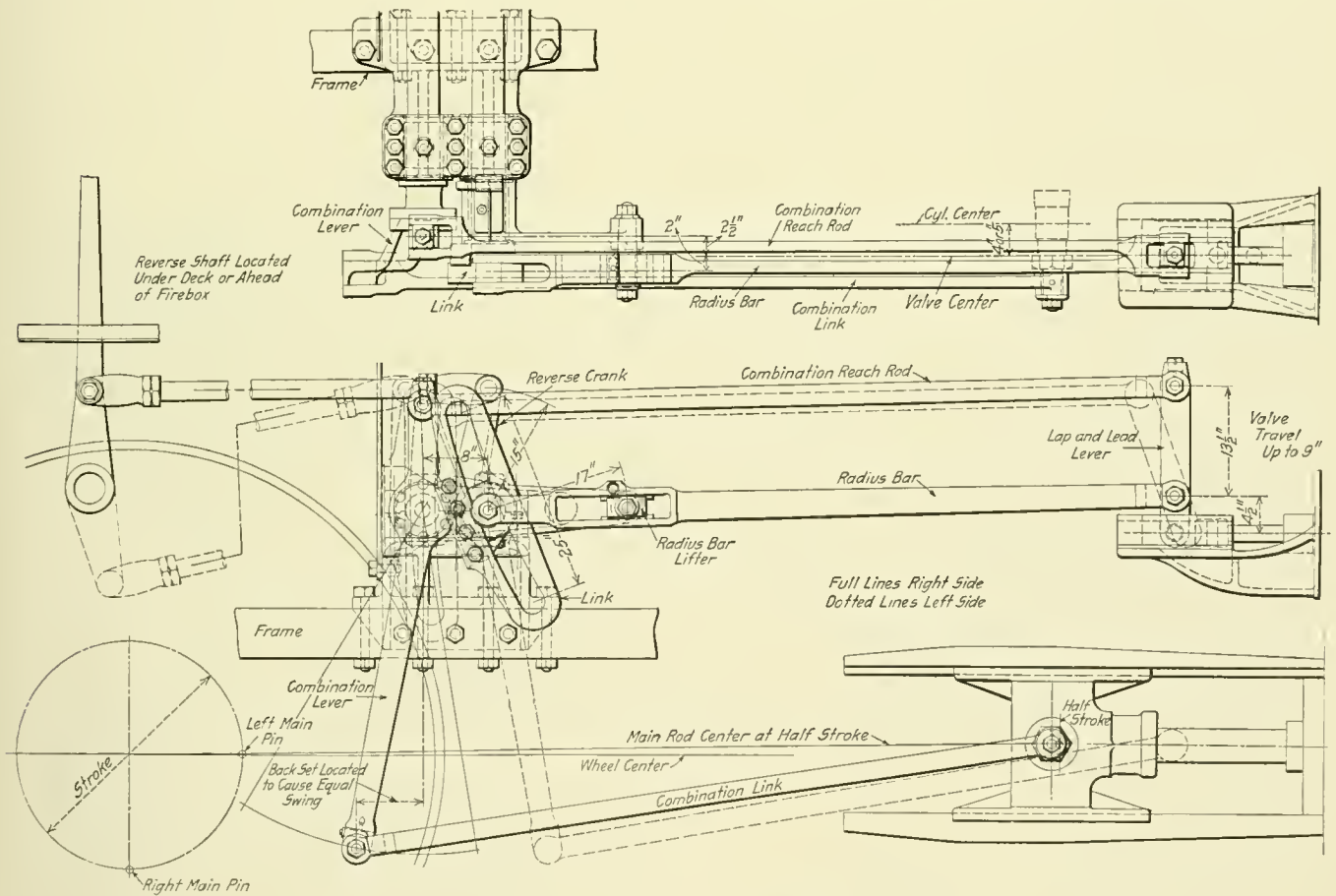

The Young Locomotive Valve Gear Is Driven Entirely by the Crossheads

ination lever which gives the valve its lap and lead movement, the same as in the Walschaert gear, is located some distance back of the crosshead and is keyed to a shaft which extends across the frames. On the opposite end of this shaft the link is keyed and gives the travel to the valve on that side. It will thus be seen that the connections to the crosshead on the right side of the locomotive provide for the lap and lead movement of the valve on the same side and the movement of the link which gives the travel to the valve on the opposite side. The same arrangement applies for the other side. Reversing is effected through a bell crank on either side that moves the radius rod by means of a block in a slotted opening. There are two reach rods, one for each side of the locomotive, and the arrangement

link and an 18 in. link block lift. For a 9 in. travel the link angle would be 47 deg. In the case of a Walschaert gear, the link angle is 50 deg. for a 7 in. valve travel with the same amount of block lift and an eccentric circle of 22 in. One setting was arranged to give no lead or pre-admission and the release and closure were very late. At a 25 per cent cutoff the port opening was  $15/64$  in. This is equal to the opening the Walschaert gear gives with a  $3/16$  in. lead. If the Walschaert gear is set with no lead, the port opening at a 25 per cent cutoff is only  $3/32$  in.

In one of the illustrations are shown the ellipses obtained from a Walschaert gear with a  $6\frac{1}{2}$  in. valve travel,  $1\frac{1}{8}$  in. lap and  $3/4$  in. lead, having a sliding block radius bar lifter. On



this is superimposed a similar ellipse from a Young gear with 8½ in. travel, 1¼ in. lap and ⅜ in. lead. It will be seen that the ellipse of the Walschaert gear is egg shaped, is fullest at the crank end and is considerable out of square in travel. This objection to the valve movement has been overcome by the Young gear and, in addition, the steam openings are 50 per cent wider at all cutoffs. The exhaust openings are also distinctly wider and the release in the higher cutoffs is more free. Closure is slightly earlier and the maximum cutoff is later.

An inspection of these ellipses would indicate that the loco-

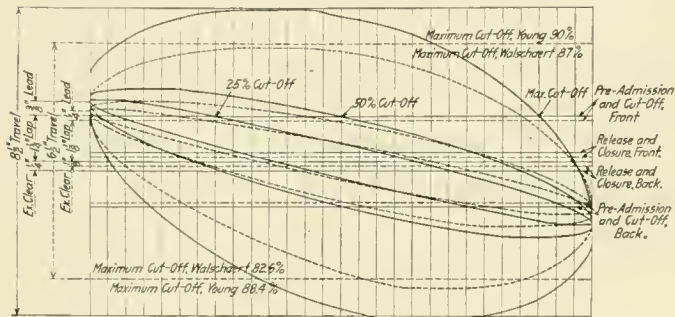

Comparative Ellipses of the Young and Walschaert Valve Gears

motive equipped with Young gear would be stronger in starting and would give considerably more power at high speed with a short cutoff. The indicator card based on this ellipse would be larger in size, showing a higher mean effective pressure, and in consequence the capacity for hauling trains would be increased.

It is from the information gained by a study of these ellipses that the statement is made that the Young gear is capable of handling as great a volume of steam with a 14 in. diameter

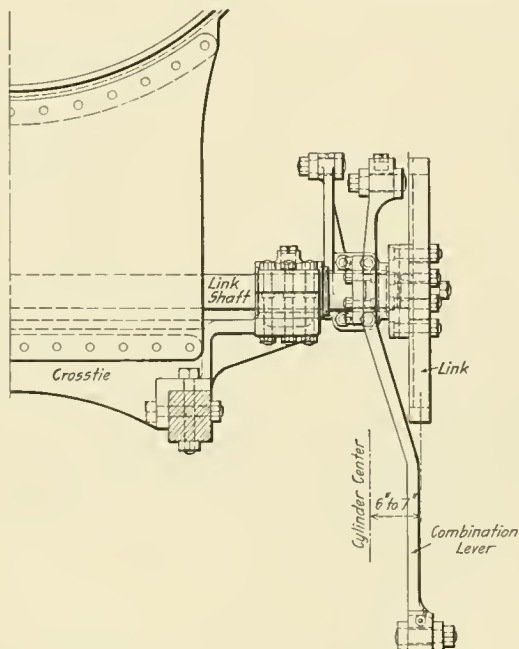

End Elevation of the Gear Showing the Location of the Link

piston valve as would a Walschaert gear with a 20 in. diameter valve. As a matter of fact, however, the 16 in. diameter piston valve is the largest size that has been used on a locomotive. This, of course, has great weight and friction, and is largely responsible for the introduction of screw and power reverse gears which are now quite generally used on the larger size locomotives. Eleven inch diameter piston valves with 28 in. port lengths are used with 20 in. diameter cylinders. These cylinders have 314 sq. in. of piston area. A 29 in. cylinder has 660

sq. in. piston area, and it has been customary to use the 16 in. diameter valve with 39 in. port lengths with this size. The port width with the Walschaert valve gear is no greater at 25 per cent cutoff in the large than it is in the small cylinders, and the increased volume for admission of steam is obtained entirely by the increase in the length of the ports. It will be seen that between the 20 in. and 29 in. cylinder, the cylinder volume has been more than doubled, but the port area has been increased only about 40 per cent. A 29 in. cylinder would require a 22 in. valve to give a port area at 25 per cent cutoff of equal ratio to the cylinder volume that an 11 in. valve bears to a 20 in. cylinder.

It would appear from this that the large engines have outgrown the capacity of the Walschaert gear and that they are not developing the hauling capacity at high speeds that they would be capable of with a freer inlet and outlet of steam. It is for this purpose, largely, that the Young gear has been designed, and it is anticipated that it will be found of especial value on very large locomotives.

### MOTOR DRIVE FOR BEAUDRY HAMMERS

An improvement recently added to the line of Peerless hammers manufactured by Beaudry & Company, Inc., 141 Milk street, Boston, Mass., is the provision for a motor drive. A description of these hammers was published in the American Engineer of

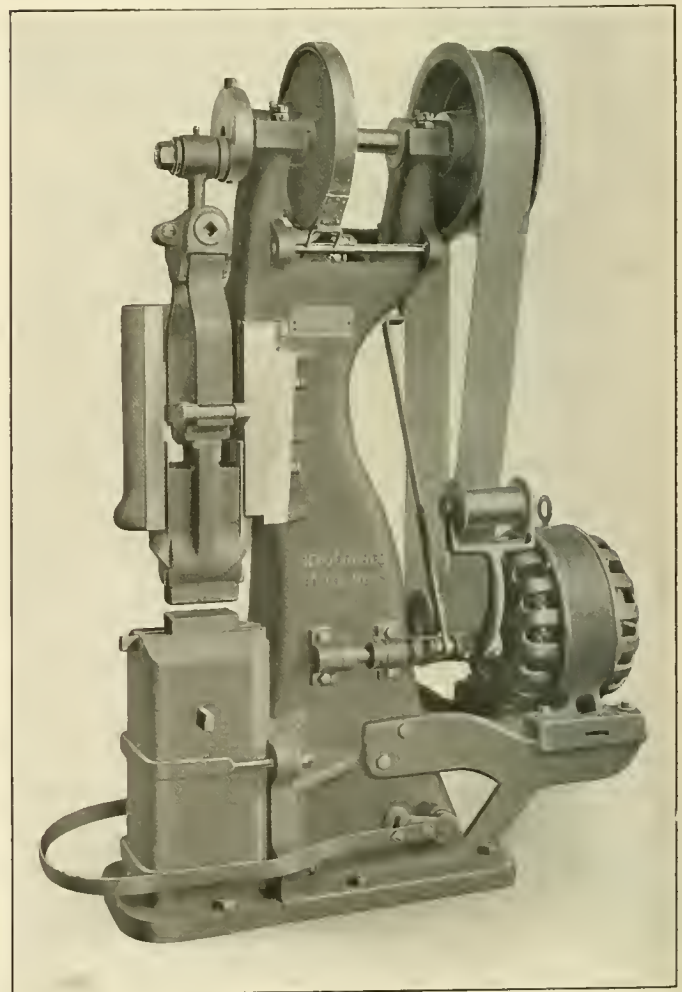

Beaudry Hammer Equipped with Motor Drive

October, 1912, page 541. The addition of the motor drive makes but few changes necessary in the construction of the hammer, the principal ones being the addition of a supporting frame for

the motor and the placing of the driving pulley outside the bearings on an extension of the shaft. These are both clearly shown in the illustration.

### CROSS-SLIDE FLAT TURRET LATHE

Among the more interesting of the recent machine tools is the cross-slide flat turret lathe designed by the Modern Machine Tool Company, Cincinnati, Ohio. This company has been building a flat rigid turret lathe for some time, which has been very popular and successful, and the new lathe differs from the rigid model only in those features of the carriage and turret directly connected with the cross slide.

Extra heavy cuts and the use of a gang of tools of large size are allowed on this machine because of the ample size and strength of all parts and the rigidity of the bed, as well as the method of supporting it. Vibration and chattering are noticeable by their absence even when high speed steel tools are used

may be used for each tool. A binder is provided for clamping the carriage to the bed during forming and cutting off operations. The backward movement of the carriage automatically turns the turret to each new position the instant the tool leaves the work and is so arranged that it may be turned to any one of the six positions without making any other stop. The adjustable dog for operating the index bar is clamped to the V and governs the position of the carriage at the time when the turret begins to revolve. The carriage is also provided with independent adjustable stops which operate automatically for each position and may be operated in any combination which may be desired when two or more are needed for any position of the turret.

The cross slide has 195 sq. in. bearing area on the carriage and has a long narrow dovetailed guide to prevent cramping. A full length taper gib takes up the wear and a parallel gib on the rear holds the cross slide in place. The center position is automatically and positively located by a taper locking bolt in the

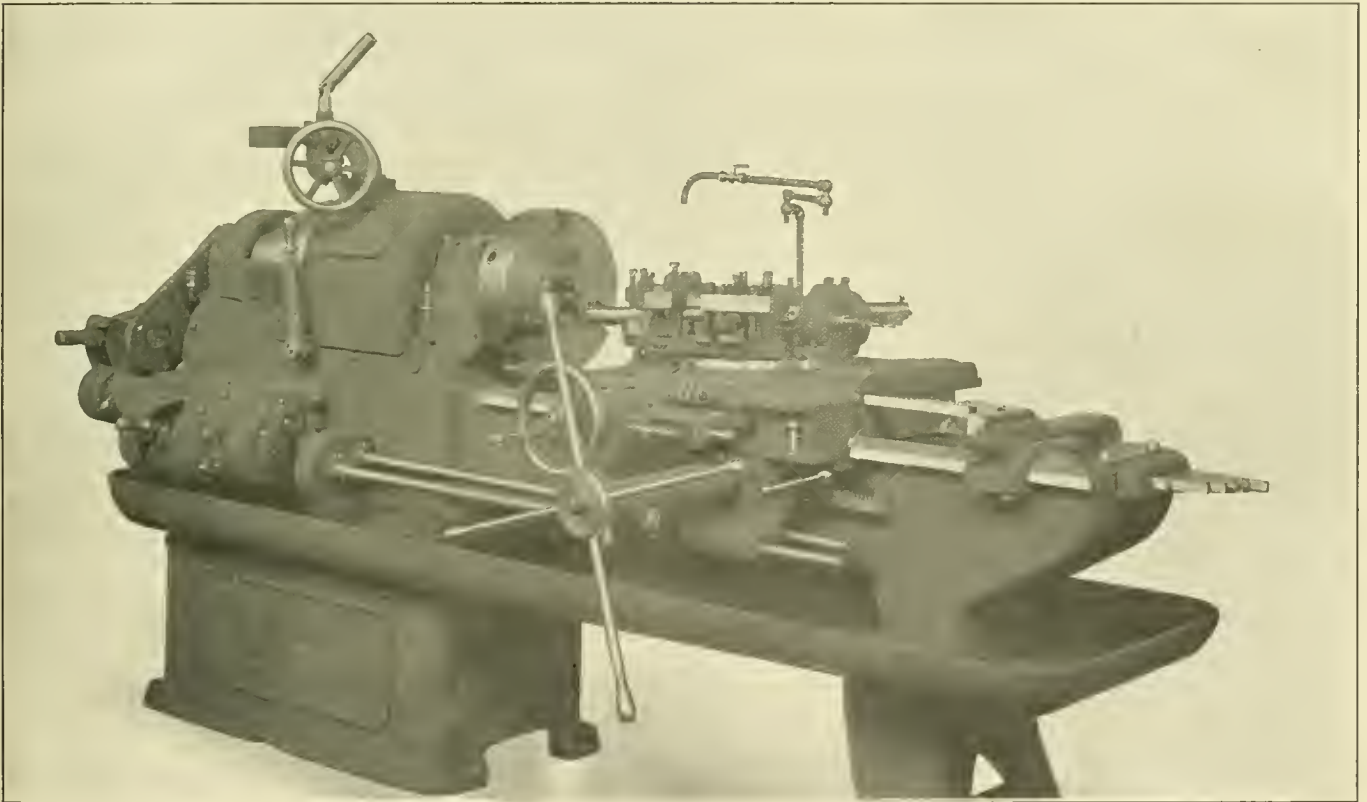

Modern Cross-Slide Flat Turret Lathe

with heavy cuts. Success in this direction implies accuracy in the finishing of the various parts of the tool and extreme care in their assembling.

The head and bed are cast in one piece. The head is friction back geared and has twelve spindle speeds in exact geometric progression. The back gears are located within the head directly under the spindle. The friction gears, roller feed and all revolving parts are enclosed and all gears and moving parts throughout the whole machine are covered to prevent injury to the operator. The machine is built to comply with the laws passed in many states in connection with the protection of workmen. The bed rests on a three point bearing and is deep and heavy, being crescent shape in section and reinforced under the front spindle bearings.

The carriage is gibbed on the outer edge of the bed by flat gibs throughout its entire length and the bearing on the bed is in full contact from end to end with the entire depth of the V's. The carriage has a system of twelve stops so arranged that two

head end of the carriage which may be disengaged when the cross feed is used.

The cross slide has ten stops which operate for either direction and it has 7 in. of travel. The stops may be used for one tool or in any combination for any series of tools. The graduations for the micrometer adjustment of the cross slides are on the periphery of the cross feed-screw hand wheel. This cross slide has independent feeds in both directions which may be engaged while the machine is in operation. The start, stop and reverse are controlled by a single lever entirely independent of the carriage feed. When the cross feed is operated by hand, the screw with two beveled gears are the only moving parts. This avoids the strain on the screw and other parts common to a heavy train of gears.

The turret is a circular plate 18 in. in diameter and the lock bolt is located close to the front edge. It is provided with T slots of ample proportions, permitting the use of substantial planer head-bolts for securing the turning tools. These can be



secured one back of another for turning several diameters at one time.

The automatic roller feed is immediately behind the front spindle bearing in the head and thus allows feeding of all of the bar or stock. There are but three moving parts or members in this feed. The automatic chuck is operated by a single movement of the lever at the front of the head. It has a strong grip, no overhang, no end motion and requires no changing of the jaws. One set of jaws is adjustable for the full capacity of the machine, namely from 5/16 in. to 2 1/4 in. The roller feed is operated by the same lever that opens and closes the chuck.

Eight positively geared feeds, ranging from .005 to .085 in. per revolution in either direction are provided by the feed gear box. Only the lever and crank handle shown at the front are needed for changing the speeds. The motion from the feed box is transferred through a disc friction and a knuckle joint to the carriage feed rod.

The machine is provided with a patented belt shifter which is operated by a hand wheel on top of the head within easy reach of the operator. Motion from the hand wheel is transmitted to the belt loop through an intermittent rack and pinion, and a similar device is suspended from the countershaft and operates in unison. The belt loops are so timed that a half turn of the hand wheel to the left shifts the belt from the larger step to the smaller on the head while the loop on the upper device holds the belt out of contact with the edge of the cone on the countershaft. The next half turn of the hand wheel moves the upper loop in line with the corresponding cone on the countershaft and completes the change.

With the cross slide lathe a 15 in. three jaw, geared, scroll chuck with four sets of jaws is regularly furnished. The principal dimensions of the lathe are as follows:

Swing over V's.....	20 in.
Swing over carriage.....	16 in.
Swing over turret.....	6 in.
Travel of carriage.....	26 in.
Travel of cross slide.....	7 in.
Hole in spindle.....	2 3/8 in.
Range of speed.....	18—350 r. p. m.
Range of feed.....	.005—.085 in.
Floor space.....	4 ft. x 11 ft.
Net weight.....	6,150 lbs.

## SOUTHERN LOCOMOTIVE VALVE GEAR\*

A new valve gear that has for its principal features simplicity in construction, directness of action and ease of control, has been invented by William S. Brown, a locomotive engineer on the Southern Railway. It is of the radial gear type, but has no connection with the crosshead. It receives its motion from an offset crank in the same manner as the Walschaert gear. The floating end of the eccentric rod has two connections, one for the radius rod and the other for the link that is fastened to one arm of a bell crank lever. The other end of this lever is attached directly to the valve rod.

It is designed to give port openings which permit of using the steam for a longer portion of the stroke without loss of power due to back pressure and wire drawing, which is a feature much to be desired, and which will permit of an increase in the tonnage hauled and lower the rate of fuel consumption. In a recent test with the Westinghouse dynamometer car a consolidation engine equipped with this gear developed a draw bar horse power of 1,074, while an engine of the same class and size but equipped with an outside gear of a different, although standard type developed only 918 h. p.

The Southern valve gear can be applied to any class of locomotive having either inside or outside valve gears. It is so designed that all movements are made as directly as possible. Inasmuch as this gear is made up of but few parts there is a correspondingly small number of pins and bearings to maintain, which is a good point in its favor. For the same reason it will be possible to keep a smaller number of parts in stock for replacement. The link is rigidly held in a horizontal position which does away with the wear at this point, as the block only moves in the link when the cut-off is being adjusted by the reverse lever. This feature also eliminates the trouble of the block slipping in the link while the engine is running, and permits of the cut-off being easily adjusted while the engine is running at a high rate of

\*From a paper presented at the November meeting of the Southern & Southwestern Railway Club by W. S. Brown, a locomotive engineer on the Southern Railway and the inventor of this valve gear.

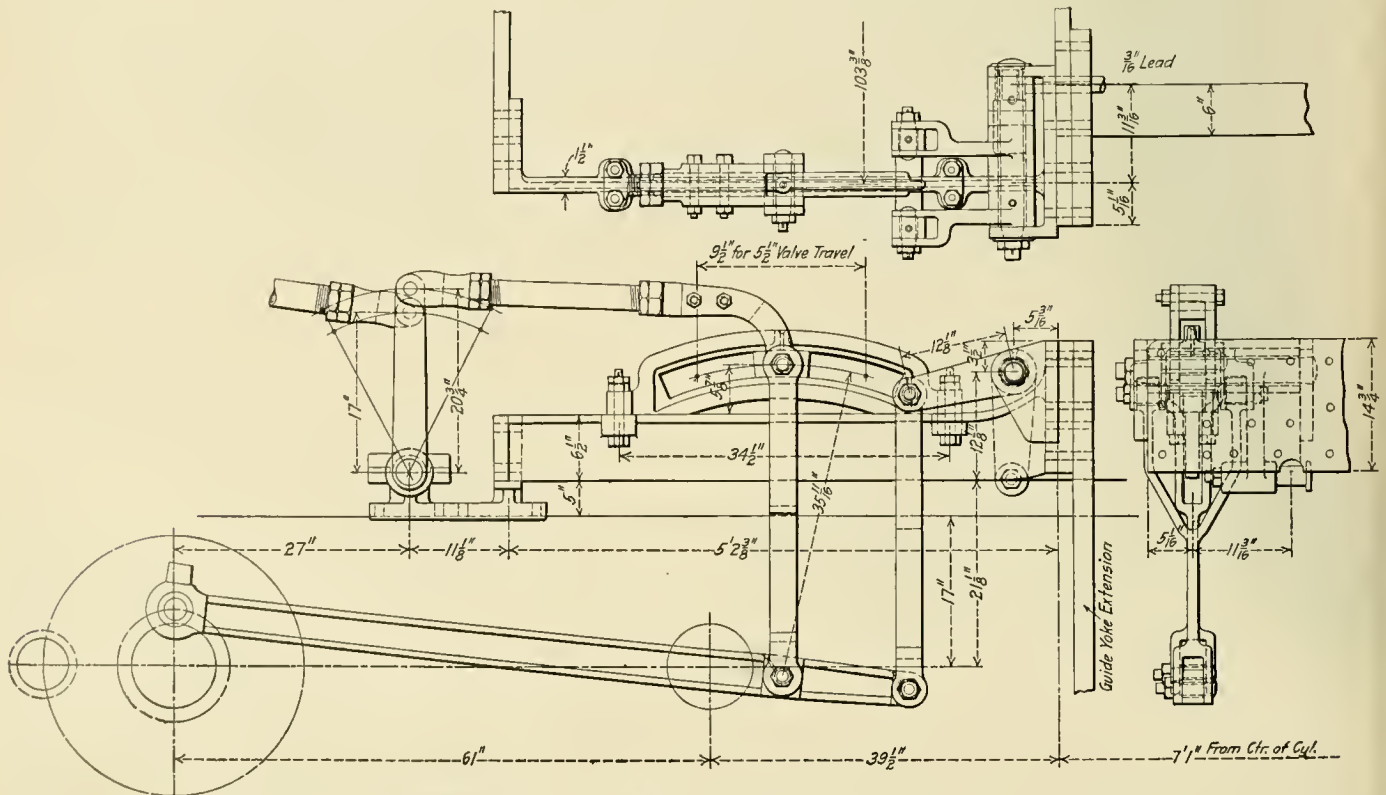

Arrangement of the Southern Locomotive Valve Gear

speed. This latter feature will be appreciated by enginemen, and will induce them to work the engines at as short a cut-off as possible, with a resulting saving in fuel.

This gear weighs 2,000 lbs., and has been applied to both passenger and freight locomotives. It has been in service on a 22 in. x 30 in. consolidation freight engine for over 30,000 miles and has not shown any appreciable wear on the pins and bush-

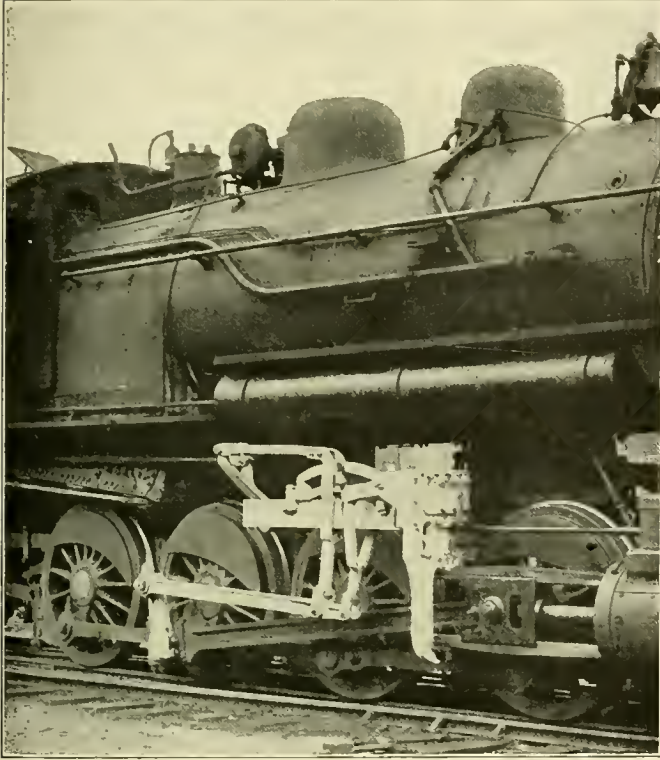

Southern Valve Gear Applied to a Consolidation Type Locomotive

ings, nor has there been any expense for repairs. It is sold by the Southern Locomotive Steam Engine Valve Gear Company, Knoxville, Tenn.

RAILWAYS OF NEW ZEALAND.—Except for 29 miles of private lines, the railways of New Zealand are in the hands of the government, which now owns and operates 2,860 miles of 3 ft. 6 in. gage line.

USE OF ALLOY STEELS.—Alloy steels are being more widely used for many locomotive parts. In most cases the heat-treated steel is employed and very excellent results are reported. In a few cases a considerable reduction of section and of weight has followed the use of this improved material. More generally, however, the greater strength has been used for the purpose of reducing the unit fiber stress and thus increasing the reliability of the parts. The alloy most generally employed has been a chrome vanadium. The number of parts of this material applied during the past year to locomotives is given in the following table:

	Number of Engines.	Number of Parts.
Axles .....	466	1,277
Crank pins .....	188	580
Piston rods .....	69	138
Main rods .....	347	734
Side rods .....	354	1,840
Springs (engine and tender).....	306	...
Frames .....	776	1,592
Engine truck axles.....	62	62
Wheels .....	...	700
Tires .....	...	1,000

The frames are simply annealed, but all other parts are heat-treated.—*Railway Age Gazette.*

## SAFETY AIR BRAKE APPLIANCE

A device which is designed to set the brakes on a train in case of the derailment of one or more pairs of wheels has been perfected by the Wright Safety Air Brake Company, Greensboro, N. C. It is automatic in its operation and consists of a spring seated release valve closing a passage from the chamber behind it which is connected directly to the train line; a protruding stem which operates the valve and a latch for holding the valve

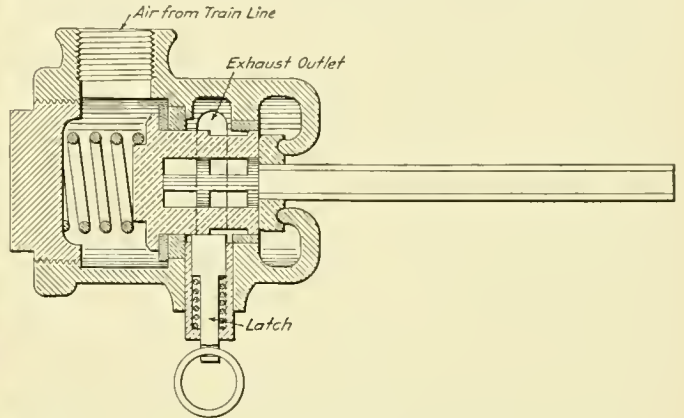

Section Through Release Valve

when opened. The device is secured to the car body on the center line and in a position relative to the truck shown in one of the illustrations. The long protruding stem passes through a yoke supported by means of a pair of brackets from the truck transom or the bolster as may be desired. The aperture in this yoke is of the shape and size determined by experience and is such as to allow free movement under safe running con-

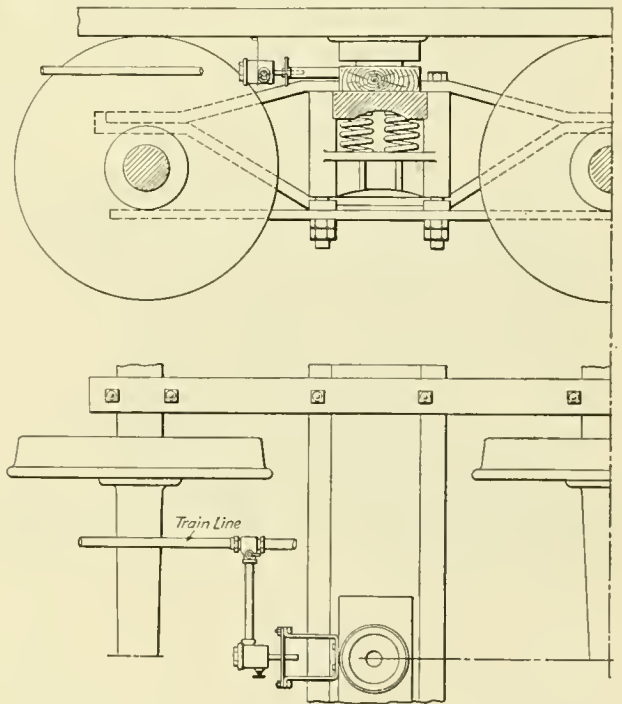

Arrangement of the Safety Release Valve on the Car

ditions without interference with the stem. An abnormal movement of the yoke, however, such as derailed wheels, serves to displace the stem and open the spring seated valve in the casing, which thus allows the air to escape from the train line and applies the brakes. When the valve has been opened a sufficient distance a latch comes in action and holds the valve in the



open position. This arrangement provides for the continual release of the air in case the stem or the operating yoke becomes broken through an excessive movement of the truck. By means of the ring shown at the bottom of the latch, the valve can be released and assumes the closed position, after the truck has been replaced and it is desired to again start the train.

This device has been in actual service on the Southern Railway for about three years. During this time it has been in the process of development and altogether there have been 29 different models used. It is believed, however, that it is now perfected and the Southern Railway is reported to be equipping a large number of cars with it.

### GEARED DRILL

A self-oiled, 22 in., all-g geared drill, of strong construction and intended for rapid production and heavy work has recently been brought out by the Barnes Drill Company, Rockford, Ill.

All bearings, aside from the spindle sleeve and cross spindles, are automatically and continuously lubricated, oil being supplied by a geared pump in the reservoir of the machine. Oil is also continuously distributed to all the gears. This self-oiling system

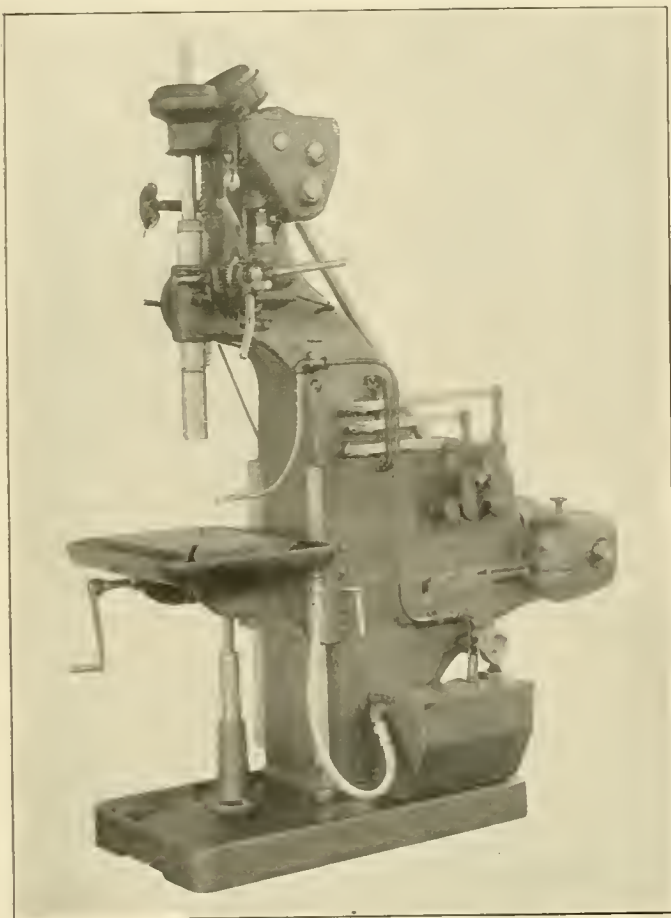

Self-Oiled 22-in. Geared Drill

is manufactured under license from Kearney & Trecker Company.

All transmission gears but those of the friction clutch, are cut from special high grade steel and heat treated. There are eight changes of speed, all controlled by levers within reach of the operator from his position in front of the machine. The spindle may be stopped by placing the shifting lever on the neutral position or by throwing out the clutch gear. There are ten instant changes of the geared feeds, also controlled by levers directly in front of the operator and the feeds are indicated in plain

figures on the index dial plate. All important feed gears are cut from steel and are case hardened. A safety collar protects the machine against damage from overload. Drills from 1/2 in. to 2 in., in diameter may be used.

In some recent tests on this machine the following results were obtained:

Size of "Celfor" Drill.	Speed, R. P. M.	Feed.	Material.	Inches Drilled per Minute.
2 in.	140	.041 in.	2 in. thick, cast iron	5 3/4
2 in.	232	.025 in.	2 in. thick, cast iron	5.8
2 in.	232	.041 in.	2 in. thick, cast iron	9.5
2 in.	367	.020 in.	2 in. thick, cast iron	7 1/4
1 1/2 in.	230	.041 in.	2 in. thick, cast iron	9.4
1 1/2 in.	367	.041 in.	2 in. thick, cast iron	15
1 1/2 in.	456	.041 in.	2 in. thick, cast iron	18 3/4
1 1/4 in.	575	.041 in.	2 in. thick, cast iron	23 1/2
1 in.	360	.025 in.	Steel	9
1 1/4 in.	350	.020 in.	Steel	7

For motor drive, the frame is strengthened and provided with a table for supporting the motor.

The following are the principal dimensions and data:

Height of machine.....	85 in.
Distance, center of spindle to face of column.....	11 in.
Maximum distance from table to nose of spindle, No. 5 taper.....	32 in.
Maximum distance from table to nose of spindle, No. 4 taper.....	33 1/4 in.
Spindle travel.....	14 in.
Diameter of spindle sleeve.....	2 3/4 in.
Diameter of spindle, driving end.....	1 3/4 in.
Diameter of nose of spindle.....	2 11/16 in.
Morse taper.....	Either No. 4 or No. 5, as preferred
Width of steel rack in spindle sleeve, 8 pitch.....	1 1/2 in.
Size of table, working surface.....	20 in. x 14 in.
Vertical travel of table.....	23 in.
Ten feed changes: .003, .005, .009, .013, .017, .020, .025, .041, .065, and .093	
Eight speed changes: Direct—575, 456, 367, 233; back gears in: 144, 114, 92, 58	
Speed of driving pulley.....	500 r. p. m.
Size of driving pulley.....	14 in. x 5 in.
Floor space, front to back.....	65 in.
Floor space, width.....	31 in.
Net weight, with regular table and oil pump attachment, without motor.....	2,620 lbs.

### CONVERTIBLE OPEN SIDE PLANER

The large size, convertible, open side planer shown in the illustration has recently been installed in one of the large eastern railroad car shops. This machine has been designed and de-

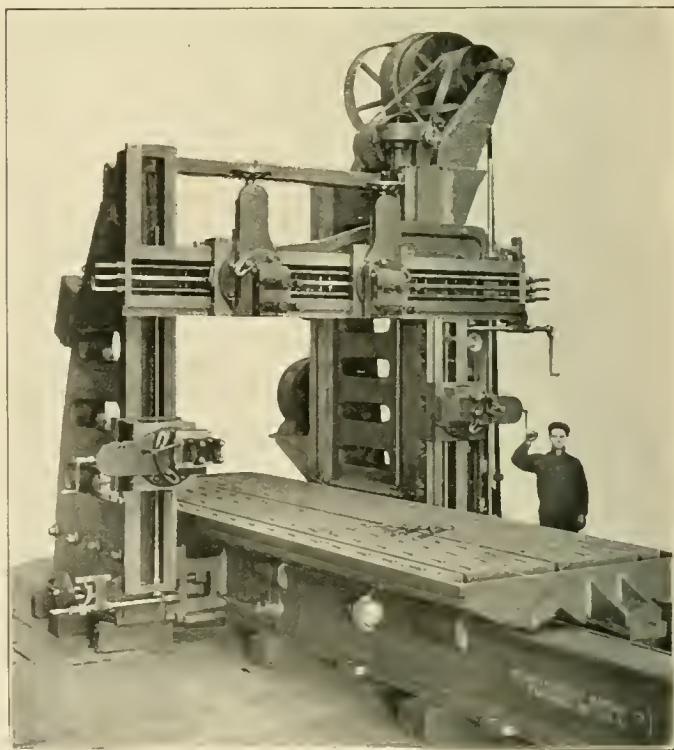

Detrick and Harvey Convertible Planer

veloped by the Detrick & Harvey Machine Company, Baltimore, Md., for the purpose of providing for a wide range of planer work, such as is frequently necessary in railroad shops.

Primarily it is a double housing planer but, through the removal of the outer housing or post, the machine is converted to an open side planer. In its usual form it provides four tool heads, two being on the cross rail and one at either side. In fact the outer housing is not intended to stiffen the cross rail or to impart any rigidity to the machine, but it is provided entirely for the purpose of carrying the outer side tool head. It can be quickly removed, leaving the machine with three tool heads and in readiness to handle any work that would not pass between the housing.

What is usually termed a cross rail in the double housing type of planer is, in this case, replaced by an L shaped casting consisting of a horizontal arm and a downwardly extending leg, cast integral therewith. This leg takes a bearing on the main housing for a distance about 50 per cent. greater than the overhang of the cross beam. The cross beam is further stiffened at the rear by a triangular brace which extends to a bearing on the main housing. This construction gives it a rigidity and strength to accurately perform very heavy work.

The side head on the right hand or operating side of the ma-

## REFRIGERATOR CAR DOOR FIXTURES

One of the principal causes of damage to shipments in refrigerator cars is due to the doors not fitting tight when closed, allowing the warm air to enter the car in summer and cold air in winter. With a view of improving this feature of the car, and also of reducing the cost of up-keep of the doors, the fixtures shown in the illustration have recently been devised.

It often happens that the doors are not tightly closed on account of the fastener bar not engaging the keeper casting either at the top or bottom. To insure the doors always being completely closed, the Garland refrigerator car door closing and opening device was designed about two years ago, and was described in this journal (March, 1912, page 139).

Even when the doors are completely closed, there are many cases where the outside air can get into the car on account of irregular or defective packing around the door casings. The packing may be heavy or thick at one side of the door and light at the other side. For the purpose of equalizing the pressure on the door packing at the sides, top, bottom, and at the center

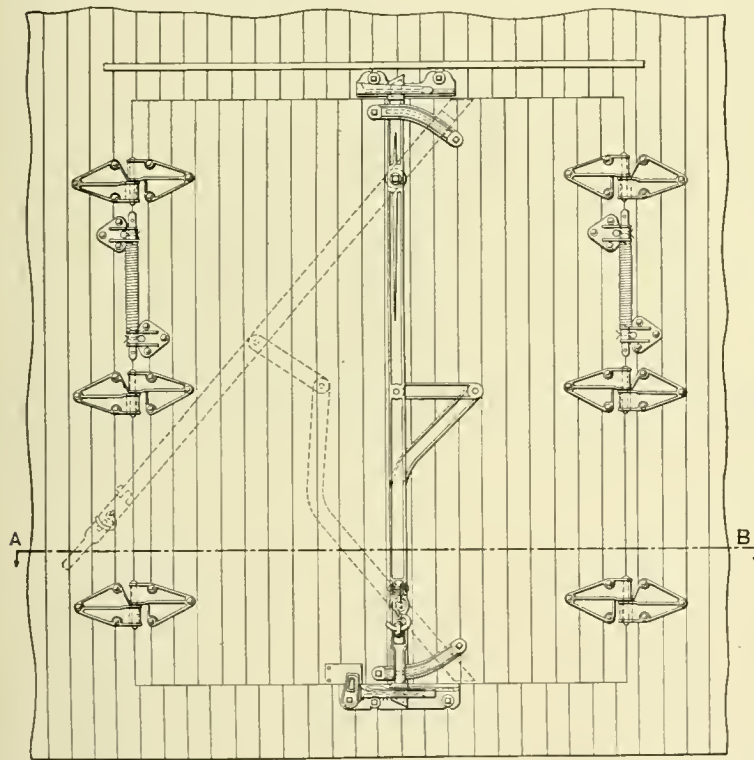

Adjustable Hinge and a Spring Closing Fixture for Refrigerator Car Doors

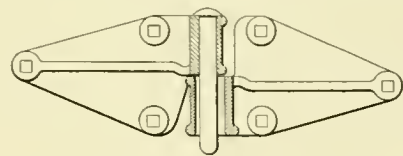

Longitudinal Section Through Adjustable Hinge.

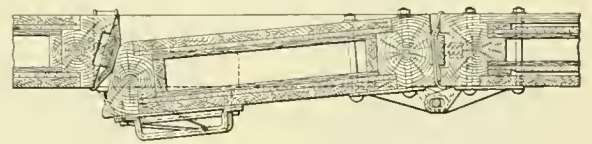

Longitudinal Section A-B Door Closing.

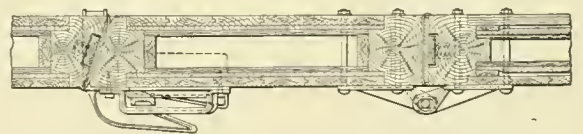

Longitudinal Section A-B Door Closed.

chine is not mounted on the housing or post, but is placed on a slideway which is secured to the downwardly projecting leg of the cross beam. The support for the tool on this head is brought as close to the housing as possible. The slideway is adjustable and, if, in the course of time, the heads on the cross rail and the side head get out of square, the error can be readily and promptly corrected by reason of this adjustability.

Spiral pinion drive has been employed because of the combination of simplicity, efficiency and power, as well as the absence of numerous parts. In this drive the pinion is only one geared train removed from the belt or motor, while in the case of a spur gear drive the wheel is four trains removed. The spiral pinion drive contains but four bearings and three gears, thus greatly reducing the friction loss.

Friction feed is provided which consumes power only when the tool is cutting. This construction is positive in action but is frictional against overload.

where the doors meet, an adjustable hinge has been devised. This allows sufficient play or movement to permit the doors when being closed to seat themselves in the door opening with equal pressure on the sides and at the center. When cars are new, the doors often bind at the center, and it is necessary to trim them off in order to get them closed. After the cars have been in service for some time the doors dry out and do not fit closely at the center. It is the purpose of this hinge to have the doors fit tightly at all times without having to make alterations after the cars go in service.

The hinges are made of malleable iron in two parts. The half that is applied to the post is made with a slotted or elongated pin hole. The hinge pin is cast in the other half that is applied to the door. When the hinges are applied and the two halves put together, the doors are allowed a lateral movement of one-half of an inch, and also an upward movement.

Another device in connection with the adjustable hinge is a



torsion spring, which is designed to operate in conjunction with the hinge. This spring is placed between the middle and upper hinge for the purpose of keeping the doors closed when they are not hooked back against the sides of the car. The desirability of having some means of keeping the doors of refrigerator cars from swinging while the cars are being switched is recognized by all who have the handling of such cars.

Many men have been killed or seriously injured by being hit by a swinging refrigerator door. There are many doors torn off every year on account of not being fastened in a closed position or hooked back against the sides of the car. The torsion spring shown is of sufficient strength to keep the doors in a closed position when not fastened or hooked back.

These devices have been designed by Thomas H. Garland, and are being handled by Mudge & Company, Railway Exchange, Chicago, Illinois.

### DIVIDED MACHINE VISE

The vise shown in the illustration is suitable for use on the tables of planers, milling machines, drills, etc., and takes the place of the ordinary machine parallel vise. It is manufactured by Schuchardt & Schutte, 90 West street, New York, and is intended to overcome the difficulties caused by the limitation in the length of the base plate of the ordinary vise. It will hold work up to the full length of the table of the machine on which



Divided Vise for Clamping Work on Machine Tools

it is used and may be used for pieces with parallel, taper or irregular lines. The jaw is fitted to the body by a sliding V and an adjustable steel gib and screws provide the necessary adjustment for wear. The action of tightening the jaws forces the work down on the table or packing and saves the operator the use of a hammer. This vise may be used for either light or heavy work, and it is claimed that it costs considerably less than the ordinary vise.

**LARGER LOCOMOTIVE CYLINDERS.**—One of the changes in proportions which has been found advisable in order to obtain the full advantage of superheated steam, is the use of larger cylinders. At first this was accompanied by a reduction in the steam pressure and the increased size of the cylinders was simply to obtain the full power with the lower pressure. Lately, however, a tendency is noted toward using larger cylinders, even with the high pressures, and some of the more recent designs would, at first sight, seem to be considerably over-cylindrical.—*Railway Age Gazette*.

**THE GREATEST RAILWAY TUNNELS.**—The world's greatest tunnels are to be found in Europe, and a brief summary of these in the *Engineer* shows that the greatest is the Simplon which is 12¼ miles in length. Two, the St. Gothard and Lotschberg, are over 9½-3 miles in length. The Mont Cenis is a little over 7 miles in length. The Arlberg, in Austria, is 6¼ miles long. There are four tunnels between five and six miles in length, five between four and five miles in length, seven between three and four miles, and sixteen tunnels that are over two miles long. The longest tunnel in this country, the Hoosac, is four and one third miles long.—*Scientific American*.

### LOCKED GREASE PLUG

Where the screw plug type of grease plug is used—and this form seems to be a favorite on a number of roads—difficulty has been found in obtaining a suitable form of locking device which will prevent the screw from backing out and not only removing the pressure from the top of the grease, but also dropping out and being lost. A form of plug which includes a locking device that will prevent this trouble is shown in the illustration. It consists of a brass body threaded on the bottom and screwed into the rod, and a wrought or cast iron hollow plug with a squared top and either a flat or hollow lower end. A suitable hinged or pivoted pawl is provided and is held in



Grease Plug Fitted with a Locking Device

place by a small coil spring. The iron plug is slotted on the side from the top of the threads to within ½ inch of the bottom of the plug, and the pawl is arranged with a lip which engages this slot when it is in the locked position. It will be seen that there is a small shoulder on the body back of the pawl. This is provided to allow the pawl to be held in an unlocked position when the plug is being removed. When locked there is no means by which the screw can back out, although it can be turned down without disengaging the pawl or giving any attention to this part.

This plug has been patented by O. N. Terry, 2404 West Division street, Chicago, Ill.

**FREIGHT CARS IN SWEDEN.**—The freight cars of Sweden are of a type similar to those generally used in England and on the continent. Swivel trucks for use on freight cars, however, are unknown in Sweden. Only the light, four-wheel cars which can be switched in yards by men without car movers, are in use in that country.

**MARINES AS ENGINEMEN AND TRAINMEN.**—Under instructions from the War Department, marines from the marine barracks, Camp Elliott, Isthmian Canal Zone, Panama, are riding on the regular passenger train locomotives of the Panama Railroad, armed with letters requesting engineers to give them all possible instructions relative to engine running, etc. This movement is being inaugurated for the purpose of having men in the marine service who can be promptly put in on railways in an enemy's territory to handle motive power and trains for the transportation of troops and provisions.—*Scientific American*.

# NEWS DEPARTMENT

The Grand Trunk shops at Port Huron, Mich., were destroyed by fire on November 26.

The repair shops of Street's Western Stable Car Line in Chicago were partially destroyed by fire on December 4, with 25 cars.

It is announced in Washington that beginning January 1 the postoffice department will abandon the practice of sending periodicals by freight trains.

L. B. Foley, superintendent of telegraph of the Delaware, Lackawanna & Western, is conducting experiments with the wireless telegraph between the company's stations at Scranton, Pa., and Binghamton, N. Y., and from these places to moving trains. A severe storm of sleet recently disabled the wires between Scranton and Binghamton, and for two hours the dispatcher sent train orders between these two stations by the wireless telegraph.

Eastbound passenger train No. 16 of the Lake Shore & Michigan Southern was derailed on the morning of December 13, about 1 o'clock, at a point near Wickliffe, Ohio, by the malicious loosening of the rails. The fireman was killed and a mail clerk was injured. A. H. Smith, the newly elected president of the New York Central Lines, was in his business car at the rear of the train. The company offered a reward of \$1,000 for the apprehension of the persons guilty of loosening the spikes and splice bars.

On the night of November 25 a special train consisting of a locomotive and two cars was run from Washington, D. C., to Jersey City, N. J., 226 miles, in four hours, the fastest trip ever made between the two cities. The route was over the Baltimore & Ohio, the Philadelphia & Reading and the Central of New Jersey. The train was run for a New York newspaper, to carry photographs taken at the marriage of the President's daughter. Enlargements of the pictures were made before leaving Washington, and some of the development work was done on the train. The train left Washington at 8:10 p. m., and arrived at Jersey City at 12:10 a. m. The best previous run between these cities, of which we find record, was 4 hours 11 minutes, over the Pennsylvania.

The American Institute of Consulting Engineers, of which Alfred Noble is president, has sent to President Wilson a letter requesting that an able and experienced engineer be appointed to one of the vacancies on the Interstate Commerce Commission. The letter points out the special fitness of an engineer to deal with questions coming before the commission concerning engineering and railroad operation. The railroad engineer's experience is useful also in dealing with the regulation of rates. The Institute has no candidate and declares that it has no motive except to serve the administration. The president is reminded that an engineer of the type under consideration would not serve in a subordinate capacity, under laymen, while yet he would probably make personal sacrifice for the honor of serving on the commission. The Institute asks not only the appointment of an engineer, but of an engineer with judicial temperament, executive ability, and the other obviously necessary qualifications for such a high office.

## THE HARRIMAN SAFETY MEDAL

At the dinner of the American Museum of Safety in New York City on Friday evening of last week, the E. H. Harriman medal, provided by Mrs. Harriman as a memorial to her

late husband, was awarded to the Southern Pacific Company. Professor F. R. Hutton in the presentation speech stated that the Southern Pacific had had no train accident fatal to a passenger during the past five years. Julius Kruttschnitt, chairman of the board of directors of the company, spoke on behalf of the road, and received a replica of the medal, which is to be made of gold.

## PRIVATE FREIGHT CARS

The Interstate Commerce Commission has completed its investigation into ownership of freight cars in the United States, and now for the first time definite figures have been gathered as to the number and character of freight equipment of American railways. According to the commission's figures there are in the United States 2,300,000 freight cars owned by the railroads and 140,000 cars owned by car companies or other private ownerships. Private parties own more refrigerator cars than the railroads, the private car lines owning 54,000 and the railroads 49,000. The investigation developed that there are 43,000 freight cars in the United States built specially for the transportation of automobiles. Early in January the commission will hold a hearing in Chicago in connection with its investigation of alleged abuses in connection with private cars.

## NEW YORK CENTRAL CAR DEPARTMENT STATISTICS

The year 1913 has been the busiest in the history of the car department of the New York Central & Hudson River and in a statement which has been issued to the officers and employees of the department thanking them for their hearty co-operation, F. W. Brazier, superintendent of rolling stock gives the following figures:

FREIGHT CARS REPAIRED.				
	Light.	Medium.	Heavy.	Total.
*New York Central cars.....	906,158	12,624	17,430	936,212
*Foreign cars .....	1,697,270	14,553	5,969	1,717,792
Total .....	2,603,428	27,177	23,399	2,654,004
*Contract shop .....	153	1	2,894	3,048
Grand total .....	2,603,581	27,178	26,293	2,657,052
*Number of passenger cars repaired.....	76,886			
Passenger cars owned, including electric cars.....	2,181			
Number of freight cars owned.....	76,850			
Number of repair yards .....	62			
Number of repair shops.....	16			
Number of men .....	7,225			
*Amount of pay roll.....	\$5,000,000.00			
*Total labor and material, approximately.....	\$14,000,000.00			

\*Months of November and December estimated.

## AN APPEAL TO PARENTS

This is the title of a "safety-first" pamphlet which has been issued by the Ohio River & Columbus, and it is being circulated among school teachers with a view to having it put into the hands of children, with the hope that they will spread the gospel to their parents. Charles J. Finger, general manager of the road, in a letter to teachers, asking their assistance, reminds them that they already do for their pupils more than the strict letter of duty requires; and on the strength of this he asks them to assume one more burden which perhaps may be unappreciated. The closing chapter of the pamphlet (the whole pamphlet fills only three pages) is in part as follows:

*Mothers, Fathers, Have You Ever Warned Your Children? Have you ever forbidden them to be in the neighborhood of the trains and station? Have you ever impressed upon them*



the danger that always lurks near a railroad? If not, will you please do so? Sensible people cannot afford to neglect this as a duty, a duty as great as that of warning them against the misuse of fire arms or any other common danger. Forbid them to be around the tracks or station or yards, except business calls them there. Forbid them under any condition to walk the track or play on railroad bridges. Crossing signs, bells, signals, warnings mean very little to a child. Children do not realize that anything can happen to them. . . .

**PAYING FOR IDEAS**

The Delaware, Lackawanna & Western has announced to its officers and employees that any suggestion, recommendation or information tending to improve the safety, efficiency or economy of the company's operations, in any direction whatever, when proffered by an officer or an employee, will be submitted to a committee for criticism; and that any device, practice or measure which such committee may approve as useful for the company will be made the subject of an award of money to the one proposing it, the award to bear a fair relation to the money value which the adoption of the improvement shall prove to be to the company. Where an employee offers a device which he desires to have patented, the company will, if the thing be patentable, secure letters patent at its own expense, for the benefit of the inventor, the inventor agreeing that the company may use the invention on its lines free of royalty. President Truesdale, in a circular congratulating officers and employees on the successful and profitable outcome of the past year's activities, gives detail instructions for the proper procedure. Everything offered must be submitted to the Registrar of Contracts, 90 West street, New York City, and from there every proposition will be sent to the committee without the name of the proposer, this to provide for absolute impartiality. The president will designate the officer or committee to investigate the merits of proposals. The sole purpose of this action by the company is to arouse and utilize the interest of every one of the employees in perfecting the Lackawanna into the most highly efficient transportation machine that it can possibly be made

**GRASHOF MEDAL PRESENTED TO GEORGE WESTINGHOUSE**

The ceremony of presenting the Grashof medal to George Westinghouse took place at the annual convention of the American Society of Mechanical Engineers on Wednesday evening, December 3. Unfortunately Mr. Westinghouse was unable to be present, and Dr. Goss, the president of the society, turned the medal over to Mr. Hartness, the president-elect, to be delivered to Mr. Westinghouse. The Verein Deutscher Ingenieure was represented by Geheimrath Romberg, G. D. Waetzoldt, Rudolph Herring, Henry Hess and Col. E. D. Meiers.

Mr. Westinghouse is the first American to receive this medal. It was founded by the Verein Deutscher Ingenieure of Germany in memory of Franz Grashof and is given by the Union only on recommendation of the council, and by

unanimous vote in open general meeting, to men who have rendered pre-eminent service in the field of engineering, either in research or in practical activity. It is the highest honor in the gift of the engineering profession of Germany. The actual award of the medal to Mr. Westinghouse was made at the fifty-fourth annual meeting of the Verein Deutscher Ingenieure in Leipzig, Germany, June 23, 1913, officers and members of the American Society of Mechanical Engineers being present. In making the presentation Dr. Oskar von Miller, president of the Union, said:

"The distinction conferred by the largest scientific and technical society in the world is not a thing that is given away on a festive occasion, nor one to serve as a mark of attention and courtesy; it can be won only by actual services for the good of humanity. Engineers will have no doubt that George Westinghouse, whose name is so well known throughout the world, does deserve this distinction."

**MEETINGS AND CONVENTIONS**

*International Railway General Foremen's Association.*—At a meeting of the Executive Committee, held in Chicago, December 9, 1913, it was decided to hold the 1914 convention July 14-17 at the Hotel Sherman, Chicago. A campaign has been started to build up the membership and strengthen the association. The following papers have been selected for the 1914 convention program: Engine House Efficiency, by W. Smith, Chicago & North Western; Cylinders, Pistons, Crossheads, Guides and Valves, by J. T. Mullin, Lake Erie & Western; The Practice and Methods of Maintenance and Repairs to the Air Brake and Its Appurtenances, by C. M. Newman, Atlantic Coast Line; Autogenous Welding, by C. L. Dickert, Central of Georgia; Subsidiary Paper No. 1, The Taylor System, by W. W. Scott, Delaware, Lackawanna & Western; Subsidiary Paper No. 2, Railroadng at a High Altitude, by J. W. Scott, Southern Railways of Peru.

*The following list gives names of secretaries, dates of next or regular meetings, and places of meeting of mechanical associations.*

- AIR BRAKE ASSOCIATION.—F. M. Nellis, 53 State St., Boston, Mass.
- AMERICAN RAILWAY MASTER MECHANICS' ASSOC.—J. W. Taylor, Karpen building, Chicago. Convention, June 15-17, 1914, Atlantic City, N. J.
- AMERICAN RAILWAY TOOL FOREMEN'S ASSOCIATION.—A. R. Davis, Central of Georgia, Macon, Ga.
- AMERICAN SOCIETY FOR TESTING MATERIALS.—Prof. E. Marburg, University of Pennsylvania, Philadelphia, Pa.
- AMERICAN SOCIETY OF MECHANICAL ENGINEERS.—Calvin W. Rice, 29 W. Thirty-ninth St., New York.
- CAR FOREMEN'S ASSOCIATION OF CHICAGO.—Aaron Kline, 841 North Fifthth Court, Chicago; 2d Monday in month, Chicago.
- CHIEF INTERCHANGE CAR INSPECTORS' AND CAR FOREMEN'S ASSOCIATION.—S. Skidmore, 946 Richmond street, Cincinnati, Ohio.
- INTERNATIONAL RAILWAY FUEL ASSOCIATION.—C. G. Hall, 922 McCormick building, Chicago. Convention, May 18-22, 1914, Chicago.
- INTERNATIONAL RAILWAY GENERAL FOREMEN'S ASSOCIATION.—William Hall, 829 W. Broadway, Winona, Minn. Convention, July 14-17, 1914, Hotel Sherman, Chicago.
- INTERNATIONAL RAILROAD MASTER BLACKSMITHS' ASSOCIATION.—A. L. Woodworth, Lima, Ohio. Convention, August 18-20, 1914, Milwaukee, Wis.
- MASTER BOILER MAKERS' ASSOCIATION.—Harry D. Vought, 95 Liberty St., New York. Convention, May 25-28, 1914, Philadelphia, Pa.
- MASTER CAR BUILDERS' ASSOCIATION.—J. W. Taylor, Karpen building, Chicago. Convention, June 10-12, 1914, Atlantic City, N. J.
- MASTER CAR AND LOCOMOTIVE PAINTERS' ASSOC. OF U. S. AND CANADA.—A. P. Dane, B. & M., Reading, Mass.
- RAILWAY STOREKEEPERS' ASSOCIATION.—J. P. Murphy, Box C, Collinwood, Ohio.
- TRAVELING ENGINEERS' ASSOCIATION.—W. O. Thompson, N. Y. C. & H. R., East Buffalo, N. Y.

**RAILROAD CLUB MEETINGS**

Club.	Next Meeting.	Title of Paper.	Author.	Secretary.	Address.
Canadian	Jan. 13	Cast Iron Wheel Records	H. H. Vaughan	Jas. Powell	Room 13, Windsor Hotel, Montreal.
Central	Jan. 9	Electro-Pneumatic Brake	Walter V. Turner	H. D. Vought	95 Liberty St., New York.
New England	Jan. 13	Training of Railroad Men	G. M. Basford	Wm. E. Cade	683 Atlantic Ave., Boston, Mass.
New York	Jan. 16	Rigid vs. Flexible Locomotive Boilers	W. J. Harkom	H. D. Vought	95 Liberty St., New York.
Pittsburg	Jan. 23	Thermit and Its Qualifications	W. R. Hulbert	J. B. Anderson	207 Penna. Station, Pittsburgh, Pa.
Richmond				F. O. Robinson	C. & O. Ry., Richmond, Va.
St. Louis	Jan. 9	The Panama Canal	W. B. Doodridge	B. W. Frauenthal	Union Station, St. Louis, Mo.

## PERSONALS

*It is our desire to make these columns cover as completely as possible all the changes that take place in the mechanical departments of the railways of this country, and we shall greatly appreciate any assistance that our readers may give us in helping to bring this about.*

### GENERAL

K. COLLETT, superintendent fuel service of the St. Louis & San Francisco, has had his title changed to superintendent locomotive performance.

P. O. WOOD has been appointed assistant superintendent locomotive performance of the St. Louis & San Francisco, with headquarters at Springfield, Mo.

W. F. DRYSDALE, mechanical engineer of the Northern Railway of Costa Rica at Limon, Costa Rica, has resigned to engage in other business.

J. V. B. DUER, foreman of motormen of the Manhattan division of the Pennsylvania Railroad at New York, has been appointed assistant engineer, with headquarters at Altoona, Pa., succeeding B. F. Wood, resigned.

J. M. HENRY, master mechanic of the West Philadelphia shops, of the Pennsylvania Railroad, has been appointed superintendent of motive power at Pittsburgh, succeeding J. M. James, resigned.

J. W. SASSER, master mechanic of the Seaboard Air Line at Jacksonville, Fla., has been appointed superintendent of motive power of the Norfolk Southern, with headquarters at Norfolk, Va.

G. CLINTON GARDNER, JR., general foreman of motive power on the Manhattan division of the Pennsylvania Railroad at New York, has been appointed assistant engineer of motive power

on the Northern division, with headquarters at Buffalo. He began railway work on February 2, 1893, on the Middle division of the Norfolk & Western as inspector at the Roanoke, (Va.) machine shop. In May, 1894, he went to the Philadelphia & Erie division of the Pennsylvania Railroad as an apprentice at the Renovo, (Pa.) machine shop and subsequently was an apprentice at the Altoona shops. After completing his apprenticeship he was made material inspector and later was assigned to special work. On March 25, 1899, he was



G. C. Gardner, Jr.

promoted to motive power inspector at the West Philadelphia shops, and about two years later was transferred to Jersey City, N. J., as motive power inspector in the office of the superintendent of motive power. In December, 1902, he was made assistant road foreman of engines on the New York division, with headquarters at Jersey City, and in April, 1905, was made assistant master mechanic at Trenton, becoming general foreman on the Belvidere division, now a part of the Trenton division, in December, 1906. In February, 1909, he was made general foreman of motive power on the Hudson division, and three years later became general foreman of motive power on the Manhattan division, in charge of enginemen, firemen, and shops.

with headquarters at New York City, which position he held at the time of his recent appointment as assistant engineer of motive power on the Northern division of the same road, as above noted.

WILLIAM GARSTANG, general master car builder of the Cleveland, Cincinnati, Chicago & St. Louis and the Peoria & Eastern, retired from railroad service at the end of the past year, after



William Garstang

an active career of 50 years in the mechanical department. Until February, 1913, Mr. Garstang was superintendent of motive power of the Cleveland, Cincinnati, Chicago & St. Louis, the Peoria & Eastern, and the Cincinnati Northern, and had held the title of superintendent of motive power for 25 years, 20 years with the Big Four and for 5 years, from 1888 to 1893, with the Chesapeake & Ohio. In February, 1913, he was relieved of a portion of his duties, and has since served mainly in an advisory capacity with the title of general master

car builder. His former duties will continue to be performed by S. K. Dickerson, superintendent of motive power, and I. S. Downing, master car builder. Mr. Garstang was born February 28, 1851, in England, and was educated in the public schools. In 1862 he carried water for the contractors on the laying of track from Fort Erie to Niagara on the Canadian shore of the Niagara river, and in December, 1863, entered railway service as a machinist apprentice on the Cleveland & Erie, now part of the Lake Shore & Michigan Southern, at Cleveland, Ohio, where he remained six years. During this period he went to night school and studied mathematics and mechanical drawing. He was then for 11 years machinist and general foreman of the Atlantic & Great Western and the New York, Pennsylvania & Ohio; for three years general foreman of the Cleveland & Pittsburgh division of the Pennsylvania; for five years master mechanic of the Cleveland, Columbus, Cincinnati & Indianapolis, now the Cleveland, Cincinnati, Chicago & St. Louis, and in 1888 he was appointed superintendent of motive power of the Chesapeake & Ohio. On April 1, 1893, he was appointed superintendent of motive power of the Cleveland, Cincinnati, Chicago & St. Louis, which position he held until February 10, 1913. He has thus been connected for approximately 30 years with Vanderbilt roads, and during that time he has been closely identified with the wonderful progress that has been made in railroading. During his first service on the Cleveland & Erie the link and pin coupler was used on passenger cars as well as freight cars; passenger cars were heated by wood stoves and lighted by sperm candles, and portable platforms were used between cars during stops to keep people from falling through; the locomotives burned wood, weighed only about 70,000 lb., and were equipped with valve gears having the hook motion and the independent cut off, and wooden brake beams, brake heads and brake shoes were used, over the route that is now traversed by the Twentieth Century Limited. Mr. Garstang has been connected with the Master Car Builders' Association and Master Mechanics' Association for about 35 years, and was president of the Master Mechanics' Association in 1894 and 1895. He has served on the committees that adopted the M. C.



B. standard car axle, journal box, journal brass, journal wedge, and the standard wheel, and for the past 12 years has been chairman of the committee on standard wheels. When this committee first took up the wheel question there were 45 different designs in use, which have now been reduced to designs for 60,000, 80,000 and 100,000 lb. capacity cars. One of his most important recent achievements was the erection of the Big Four shops at Beech Grove, Ind., which he designed and contracted for, and the work was carried on under his supervision, in addition to his other duties.

#### MASTER MECHANICS AND ROAD FOREMEN OF ENGINES

CHARLES BOWERSOX, general foreman of the Toledo & Ohio Central at Bucyrus, Ohio, has been appointed master mechanic at that point.

C. C. ELMES has been appointed road foreman of engines of the Philadelphia & Reading, with headquarters at Tamaqua, Pa.

FRANK W. MAYO, engine house foreman at the Sunnyside Yards, Manhattan division of the Pennsylvania Railroad at Long Island City, has been appointed acting road foreman of engines of the Manhattan division, in charge of electric and steam service, and will continue in charge of the engine house at Sunnyside Yards, with headquarters at New York. The positions of foreman of motormen and general foreman of motive power have been abolished.

L. SHOWELL has been appointed division foreman of the Atchison, Topeka & Santa Fe at Deming, N. M., succeeding G. J. Kintz.

PHILIP STOHLBERGER has been appointed road foreman of engines of the Atlantic City Railroad, with headquarters at Atlantic City, N. J.

#### CAR DEPARTMENT

C. M. BURCHER has been appointed car foreman of the Atchison, Topeka & Santa Fe at Amarillo, Tex., succeeding E. A. Bronson.

R. V. CARLETON has been appointed general foreman of the passenger car shops of the Canadian Pacific at West Toronto, Ont.

F. J. HARPER has been appointed traveling piece work supervisor of the St. Louis & San Francisco, with headquarters at Springfield, Mo.

DAHL HOLCOMB has been appointed foreman of steel car repairers of the Atchison, Topeka & Santa Fe at San Bernardino, Cal.

GEORGE H. O'BRIEN has been appointed car foreman of the Atchison, Topeka & Santa Fe at Wellington, Kan., succeeding C. M. Burcher, transferred.

R. W. PRITCHARD has been appointed assistant superintendent, car department, of the Terminal division of the Rock Island Lines, with headquarters at Chicago.

F. REEVE has been appointed coach yard foreman of the Canadian Pacific at Vancouver, B. C., succeeding W. Woodhouse.

W. WOODHOUSE has been appointed car shop foreman of the Canadian Pacific at Vancouver, B. C., succeeding L. L. Hannah.

#### SHOP AND ENGINE HOUSE

H. ALLEN has been appointed locomotive foreman of the Canadian Pacific at Alyth, Alta., succeeding W. G. McPherson.

W. J. ANDREWS has been appointed locomotive foreman of the Canadian Pacific at Minnedosa, Man.

E. A. BARNWELL has been appointed locomotive foreman at the

West Calgary roundhouse of the Canadian Pacific, West Calgary, Alta., succeeding J. Reed.

GUY T. FOSTER has been appointed roundhouse foreman of the Atchison, Topeka & Santa Fe at Shawnee, Okla., succeeding P. S. Hoffar.

J. E. GILES has been appointed shop foreman of the Canadian Pacific at Lethbridge, Alta.

EDWARD P. GRAY has been appointed general foreman of the Atchison, Topeka & Santa Fe at Arkansas City, Kan., succeeding B. A. Eldridge.

J. HONAN has been appointed locomotive foreman of the Canadian Northern at Kindersley, Sask., succeeding W. Toll.

CHAS. JOHNSON has been appointed division foreman of the Atchison, Topeka & Santa Fe at Williams, Ariz.

D. G. McDONALD has been appointed locomotive foreman of the Canadian Pacific at Macleod, Alta., succeeding J. A. Maddick.

H. McHARDY has been appointed locomotive foreman of the Canadian Pacific at Neudorf, Sask., succeeding W. J. Andrews.

W. G. McPHERSON has been appointed locomotive foreman of the Canadian Pacific at Moose Jaw, Sask.

C. D. MACK has been appointed general foreman of the Atchison, Topeka & Santa Fe at Winslow, Ariz., succeeding G. F. Tilton.

J. A. MADDICK has been appointed locomotive foreman of the Canadian Pacific at Crowsnest, B. C.

J. MORTON has been appointed locomotive foreman of the Canadian Pacific at Konora, Ont., succeeding J. H. Wilson.

DENNIS QUINLAN has been appointed assistant boiler shop foreman of the Atchison, Topeka & Santa Fe at Albuquerque, N. M., succeeding Roy Welch, promoted.

J. REED, locomotive foreman of the Canadian Pacific at West Calgary, Alta., has returned to his former position as shop foreman at Alyth, Alta.

W. TOLL has been appointed locomotive foreman of the Canadian Northern at Hanna, Alta.

ROY WELCH has been appointed foreman of boiler repairs of the erecting shop of the Atchison, Topeka & Santa Fe at Albuquerque, N. M., succeeding Dahl Holcomb, resigned.

#### PURCHASING AND STOREKEEPING

J. R. ORNDORFF has been appointed assistant storekeeper of the Baltimore & Ohio at Mount Clare shops, Baltimore, Md.

W. H. WILLIAMS has been appointed storekeeper of the Baltimore & Ohio, with headquarters at Ivorydale, Cincinnati, Ohio, succeeding F. A. Murphy.

**SPEED OF EARLY LOCOMOTIVES.**—A speed of 40 miles an hour with a light load, has been obtained upon the Manchester railway; and Mr. G. Stephenson, the engineer, has stated his opinion that an engine might be constructed to run 100 miles within the hour, although he acknowledges that "at that rapidity of motion the resistance of the atmosphere would be very considerable." Engines are now made with eight times the power of the Rocket, yet with little more weight resting on each rail, the load being equally divided upon six wheels, and the machinery placed in a more advantageous situation than formerly. The tubes of the boiler are made smaller and more numerous, and of brass instead of copper. The last engine put on the railway ran 23,000 miles with the most trivial repairs, taking every day four or five journeys of thirty miles each.—*From the American Railroad Journal, March 15, 1834.*

## SUPPLY TRADE NOTES

The Railway Utility Company, Chicago, has abandoned its branch office in Vancouver, B. C.

W. H. Snedaker, local manager of the Griffin Wheel Company's plant at Tacoma, Wash., has been elected a vice-president of that company, with office at Tacoma.

Franklin L. Whitcomb has been elected president of the Griffin Wheel Company, with headquarters at Chicago, Ill., succeeding Thomas A. Griffin. Mr. Whitcomb was born at Worcester, Mass., on March 5, 1862. His first business experience was with a commercial wool house in Boston from 1882 to 1884. He then went to Cleveland, where he was in the boot and shoe business for two years. For two years, from 1886 to 1888, he was with the Atchison, Topeka & Santa Fe, in the purchasing department at Topeka and at Chicago, and since 1888 he has been with the Griffin Wheel Company. He was general sales agent of that company until 1909, and in



F. L. Whitcomb

that year he was elected to the vice-presidency, from which position he has just been promoted to that of president.

W. W. Butler has incorporated and is president of the W. W. Butler Company, Ltd., of Montreal, Que. The new company will engage in the business of selling railway, marine and mining supplies; it is capitalized at \$100,000 and will have offices in the Transportation building, Montreal. It will represent J. Stone & Company, Ltd., of London, who manufacture complete systems of electric train lighting, and the Canadian Gold Car Heating & Lighting Company, Ltd. It will also represent the American Steel Foundries in Canada, and will have the railroad selling agency for the Glidden Varnish Company. Mr. Butler will retain his interest in the Canadian Car & Foundry Company, the Canadian Steel Foundries, Ltd., and the Pratt & Letchworth Company, Ltd. He has in addition taken a controlling interest in the Dominion Lubricating Oil Company. With him is associated George T. Merwin, who formerly represented the Safety Car Heating & Lighting Company in Canada.



W. W. Butler

The Pittsburgh Steel Products Company, Pittsburgh, Pa., has opened an office at 1933 Railway Exchange building, St. Louis,

Mo., in charge of A. F. McCoolle, manager of sales, and C. F. Palmer, supervisor.

Frank A. Purdy, who for seven years has been manager of the Canadian Gold Car Heating & Lighting Company at Montreal, has been transferred to the New York office of the Gold Car Heating & Lighting Company. He will bear the title of sales manager for the Canadian company and also for the Gold Car Heating & Lighting Company in the United States, with headquarters in New York City. The W. W. Butler Company, Ltd., of Montreal, will act as selling agents for the Canadian Gold Car Heating & Lighting Company. Mr. Purdy was born in the central part of New York State in 1866. His family moved to Iowa in 1868. He began railroad work in 1887 as fireman on the Burlington, Cedar

Rapids & Northern, now part of the Rock Island system, where he remained until 1892, when he went to Chicago to engage in the livestock commission business. In 1905 he joined the staff of the Gold Car Heating & Lighting Company. For about two years he did general field work on the selling force, subsequently being appointed to manage the Canadian company.

Charles W. Allen, manager of the railway department of the Reading-Bayonne Steel Casting Company, Reading, Pa., has been made vice-president and a director of the Reading Specialty Company, a company recently organized to sell the cast steel products of the Reading-Bayonne Steel Casting Company. Mr. Allen received his education in the Tam-aqua (Pa.) schools and served as a machinist's apprentice in the Tam-aqua shops of the Philadelphia & Reading. He later became engine house foreman at Milton, where he remained for six years. In 1904 he was transferred to Reading as master mechanic of the Reading & Harrisburg division. He left this position on January 1, 1907, to become railroad representative of the L. S. Bordo Company, with which he remained until his appointment as manager of the railway department of the Reading-Bayonne Steel Casting Company. He is the son of G. S. Allen, one of the oldest members of the Master Mechanics' Association, who was formerly a master mechanic of the Philadelphia & Reading, and who served that road for 54 years.



C. W. Allen

The Canadian H. W. Johns-Manville Co., Limited, has moved its Toronto branch to No. 19 Front street, East. The new store and warehouse has a floor area of approximately



35,000 sq. ft. and is situated in the heart of the wholesale district.

Thomas A. Griffin has been elected chairman of the board of directors of the Griffin Wheel Company, Chicago. Mr. Griffin was born August 28, 1852, at Rochester, N. Y. His first business

experience was as an apprentice at Rochester, and he has been in the car wheel manufacturing business continuously since 1868. He went to Detroit in 1875 and operated for the Michigan Car Company its plant known as the Detroit Car Wheel Company, manufacturing all the wheels made and used by the Michigan Car Company. In 1879 the Griffin Car Wheel Company of Detroit, was organized and a foundry built by T. F. Griffin, his father, associated with T. A. Griffin and P. H. Griffin. The following year Thomas A. Griffin



T. A. Griffin

went to Chicago, where he organized the Griffin & Wells Foundry Company, and in 1886 this company was merged into the Griffin Wheel & Foundry Company, Mr. Griffin at this time acquiring all of the interest in the Griffin Car Wheel Company at Detroit. Subsequently the name of the company was changed to Griffin Wheel Company. Besides having five foundries in Chicago the company operates foundries in Boston, St. Paul, Detroit, Kansas City, Denver and Tacoma, and a plant is being built at Los Angeles.

Robert Christy Totten, president of the Nickel Chrome Car Wheel Company, Pittsburgh, Pa., died recently. Mr. Totten was born in Pittsburgh on January 6, 1833, and lived in

that city his entire life with the exception of three or four years spent in St. Louis. His father was one of the earliest iron founders in the Pittsburgh region and organized the old Fort Pitt Foundry, which did a great deal of work for the United States government during the Mexican war in the casting of cannon. At the death of his father, which occurred in 1850, Mr. Totten, then only about 17 years of age, entered the foundry and continued in that business until about 1891. Since that time he had been engaged, to a greater or



R. C. Totten

less degree, in the study of metallurgy, especially in connection with improvements in chilled iron castings. At the time of his death he was engaged in exploiting an invention relating to the use of nickel and chrome to chill iron for the manufacture of car wheels.

## CATALOGS

**SELF-OPENING DIE.**—A particularly interesting, fully illustrated discussion of the arrangement and operation of thread cutting dies is given in a catalog prepared by Wells Brothers Company, Greenfield, Mass. In addition to the discussion on the general principles of successful dies, the catalog contains illustrated descriptions of the type of self-opening die perfected by this company. This catalog includes information which will be of assistance to tool room foremen.

**CAR WHEEL LATHE.**—The new Putnam 42 in. coach and tender wheel lathe is well described in a leaflet being sent out by Manning, Maxwell & Moore, 119 West Fortieth street, New York. This lathe is a distinct advance in its field and provides for the turning of a pair of coach or tender truck wheel tires with only two operations and without the necessity of a single change of cutting tools. The new details used on the machine are separately illustrated and described in this leaflet.

**STEEL AXLES.**—A catalog from the Illinois Steel Company, Chicago, Illinois, contains the full text of the Master Car Builders' Association standard specifications for steel axles and also the standard specifications for car and tender axles prepared by the Illinois Steel Company. Illustrations are included showing the standard M. C. B. and A. S. & I. R. standard axle. A brief discussion of the proper method of manufacture as it is done at the Illinois Steel Company's mills forms the introduction.

**PLANING MACHINES.**—A catalog devoted entirely to planing machines of various kinds has been prepared by the Betts Machine Company, Wilmington, Del. Planers in sizes from 36 in. to 150 in. by 144 in. are illustrated, and in each case the facing page contains a full but brief description of the construction. In addition to the complete machines, the catalog also contains illustrations and descriptions of some details. Reversing motor drive in connection with several sizes of these machines is also illustrated.

**FURNACES.**—"The cost of fuel is not as important as what you can get out of it, and this depends on how you utilize it, which in turn is governed by your furnace design and operation." The discussion in a catalog issued by the W. F. Rockwell Company, 50 Church street, New York, is largely based on this statement. It fully describes the construction and operation of various sizes and types of Rockwell furnaces and illustrates designs for a great variety of uses. Many of these are suitable for use in railroad shops.

**AIR COMPRESSORS.**—The "Story of the Imperial" is the title of a booklet just issued by the Ingersoll-Rand Company, 11 Broadway, New York City. It outlines in a brief form the features of the design and construction of the Imperial line of air compressors. It is arranged to give the reader a thorough understanding of the various steps in the construction of the machine showing how the air compressors are designed and built. Each important operation in the manufacture is illustrated with excellent reproductions of photographs.

**PACIFIC TYPE LOCOMOTIVE.**—Bulletin No 1,016 from the American Locomotive Company, 30 Church street, New York, briefly considers the field of train operation to which the Pacific type locomotive is especially adapted, and includes in its 19 pages, photographs of 42 designs that have recently been built by this company. A tabular comparison of an equal number of locomotives giving the full dimensions of each is also included. This is a very complete exhibition of the 4-6-2 type locomotives that have proven successful under many variations of traffic conditions in both passenger and freight service. The locomotives shown have weights on drivers ranging from 122,500 lbs. to 197,800 lbs.

# Railway Age Gazette

MECHANICAL EDITION

INCLUDING THE  
AMERICAN ENGINEER

PUBLISHED ON THE FIRST THURSDAY OF EVERY MONTH BY THE  
SIMMONS-BOARDMAN PUBLISHING COMPANY,  
WOOLWORTH BUILDING, NEW YORK, N. Y.

CHICAGO: Transportation Bldg. CLEVELAND: Citizen's Bldg.  
LONDON: Queen Anne's Chambers, Westminster.

EDWARD A. SIMMONS, *President*. L. B. SHERMAN, *Vice-President*.  
HENRY LEE, *Secretary*.

The address of the company is the address of the officers.

ROY V. WRIGHT, *Editor*.

E. A. AVERILL, *Managing Editor*. A. C. LOUDON, *Associate Editor*.  
R. E. TRAYER, *Associate Editor*. GEORGE L. FOWLER, *Associate Editor*.

Subscriptions, including the eight daily editions of the *Railway Age Gazette* published in June in connection with the annual conventions of the Master Car Builders' and American Railway Master Mechanics' Associations, payable in advance and postage free:

United States, Canada and Mexico.....	\$2.00 a year
Foreign Countries (excepting daily editions)....	3.00 a year
Single Copy .....	20 cents

Entered at the Post Office at New York, N. Y., as mail matter of the second class.

WE GUARANTEE, that of this issue 4,400 copies were printed; that of those 4,400 copies, 3,767 were mailed to regular paid subscribers and 150 were provided for counter and news companies' sales; that the total copies printed this year to date were 8,650—an average of 4,325 copies a month.

VOLUME 88

FEBRUARY, 1914

NUMBER 2

## CONTENTS

EDITORIALS:	
Reinforcing Wooden Box Cars .....	57
The Training of Railway Men.....	57
Pennsylvania Atlantic Type Locomotive.....	58
Refrigerator Car Design.....	58
The Road Foreman of Engines.....	59
New Books .....	60
COMMUNICATIONS:	
Turning Driving Wheel Tires.....	61
Does This Fit Your Shop?.....	61
Young Valve Gear.....	61
College Men and the Railroads.....	62
GENERAL:	
Nctable Atlantic Type Locomotive.....	63
Development of Young Men in Railroad Work.....	69
Lehigh Valley Tender Tank.....	72
College Men in Railroad Work.....	73
Soda Ash Feeder for Boiler Feed Pumps.....	74
CAR DEPARTMENT:	
High Capacity Well Car.....	75
Dining Cars for the Burlington.....	77
Grain Tight Construction for Single Sheathed Box Cars.....	81
Cast Iron Wheel Records.....	82
Reinforcing Wooden Box Cars on the Canadian Pacific.....	86
SHOP PRACTICE:	
Tool Room Equipment and Management.....	87
Protection of Grinding Wheels.....	88
Special Tools in the Machine Shop.....	89
Lubricating Bottom Guide Bars.....	91
Machining Pistons on a Vertical Turret Lathe.....	92
Dial Rims for Adjusting Gage Hands.....	92
Saving Time in the Paint Shop.....	93
Jig for Machining Eccentrics.....	94
Portable Tire Heater.....	94
Powdered Fuel for Railway Shops.....	95
Devices for Shop Use.....	97
NEW DEVICES:	
Four Spindle Radial Drilling Machine.....	99
Car Wheel Drop Pit.....	100
Union Drop Brake Shaft.....	101
Roller Friction Clutch for Throttle and Reverse Levers.....	101
Cincinnati Eighty-Four Inch Planer.....	102
Pneumatic Drills Equipped with Roller Bearings.....	102
Air Ventilated Journal Box.....	103
Pocket Slide Rule.....	103
Locomotive Fire Door.....	104
Countersinking Machine.....	104
NEWS DEPARTMENT:	
Notes.....	105
Meetings and Conventions.....	106
Personals.....	107
Supply Trade Notes.....	108
Catalogs.....	110

### Reinforcing Wooden Box Cars

The wooden box car that is too good to scrap and yet not strong enough to meet modern service conditions, forms a serious car department problem. In many cases the problem has been successfully solved by rebuilding the cars and adding steel underframes. While the life of such cars can be lengthened and their capacity increased by thus rebuilding them, it is always an expensive way out of the difficulty and is not always justified. The method employed in reinforcing wooden box cars on the Canadian Pacific, which is described elsewhere in this issue, is of special interest because of its simplicity and cheapness, and because the work can be done at almost any car repair yard. In strengthening the ends of these cars no expense is involved in tearing out the old material. Even if the old end posts are cracked they and the old lining are left in place and the reinforcement placed over them. The large number of cars which have been strengthened in this way have justified the application of this end reinforcement and the Z-bar center sills, as the repairs afterward found necessary are no more extensive than if an entire steel underframe had been employed.

### The Training of Railway Men

In the address presented by George M. Basford at the January meeting of the New England Railroad Club, a portion of which is reprinted in this issue, the railway men of this country received a warning. Will the warning be heeded, or when skilled men are needed, will the practice be continued of "Making them overnight from anything with two hands that comes along?" The type of man that the railway conditions of today demand cannot be developed overnight, nor in a few days or a few weeks. The one solution of this problem is careful selection and systematic training over a period of years; in a word, apprenticeship.

A vital point in the training of apprentices, on which emphasis was laid in this paper, is the keeping of the boys on the road after their apprenticeship is completed. In dealing with this Mr. Basford says: "Is your organization qualified to receive and retain apprentices when through their time? If not you have a great work to do before you begin to talk about training young men for railroad service. Do you encourage capable young men, and do you have automatic means whereby able men will reveal their qualifications for promotion? Do you promote men and thereby encourage your subordinates or do you import strangers when you have good places to fill? If you cannot answer these questions look up the plan for studying and recording the characteristics of men, which was so successfully introduced on the Lake Shore & Michigan Southern (see *American Engineer*, December, 1908,) about five years ago by LeGrand Parish. Does your president give it out as a basic principle of organization that every officer on the road must train and otherwise educate his own successor? Progressive promotion presents a problem, but until it is solved or partially solved, it is fruitless to consider recruiting systems. The best possible recruiting and training methods will fail if recruits, however well trained, are brought up against continual discouragement."

In order to keep apprentices on the payroll after graduation they should be given journeymen's wages. That this is realized on the New York Central is indicated by the fact that 84 per cent of the apprentices who graduated in 1912 and 86 per cent of those who graduated in 1913 were given journeymen's rates and remained in the service of the company.

In discussing Mr. Basford's paper, F. W. Thomas, supervisor of apprentices of the Atchison, Topeka & Santa Fe, said: "While authority was given us nearly seven years ago



to experiment with an apprenticeship scheme for two or three years, it has long since passed the experimental stage and the Santa Fe would no more think of abolishing its apprentice system than it would of abolishing its power houses and tool rooms. Everything put forth by Mr. Basford in this paper, and even more, has been proven to be more than true. During this time we have filled a number of our shops with bright, aggressive, active, ambitious young men, thoroughly skilled in their trades, and 70 per cent of all the apprentices graduated during the past seven years are still in service, and over 10 per cent have been given some official position. While formerly we had to employ from two to three thousand men annually to keep our shops going, it is the prediction now that within two years from this date it will not be necessary for the road to go outside to employ any skilled mechanics. This road does not consider the educating and training of the apprentices in the shop as an expense, but considers it an investment."

Wherever apprenticeship has been given a fair trial the success has been immediate, and the results that are being realized by the comparatively few roads that have installed such a system prove beyond question that apprenticeship is no longer an experiment.

#### Pennsylvania Atlantic Type Locomotive

In the last analysis to bring a heavy passenger train to high speed and to maintain the speed, means simply boiler capacity in the locomotive. This, of course, assumes that the cylinder passages are suitably designed to allow the locomotive to run at high speed at a fairly long cut off. Therefore there is no particular advantage in using a Pacific type locomotive in preference to an Atlantic type provided the latter has as large a boiler as the former. It is a simple matter to use the same size cylinders in the two cases and deliver the same power. Limitations of the weight allowed per axle of passenger locomotive on most roads, however, compel the use of three driving axles in order to carry the requisite boiler to supply the power needed for the heavy train. These weight limitations are, of course, principally governed by considerations that affect the track structure rather than any feature of design of the locomotive.

It was believed by the locomotive designers of the Pennsylvania that it would be possible to build an Atlantic type locomotive which would have sufficient boiler capacity for very heavy passenger work and still not have any more serious effect on the track than the Pacific type locomotives in use. They realized, of course, that this large boiler was going to place great weight on the drivers, but believed that by extreme care in the design of the reciprocating parts, it would be possible to so reduce the weight in the counterbalance as to bring the combined static and dynamic weight on the track to a figure below that ordinarily given by locomotives with much less dead weight on the axle. This they proceeded to do and with complete success. To be sure, the weight per driving axle is nearly 67,000 lb. at the rail, but, on the other hand, the weight of the reciprocating parts on each side of the locomotive is but 1,000 lb. Balanced for 70 miles an hour, with 80 in. drivers, the dynamic augment of the counterbalance weight is less than 30 per cent of the static weight on the wheels and, when combined with the static weight, gives a total blow on the rail of less than 87,000 lb. This is little, if any more than the blow given by most Pacific type locomotives which have 55,000 lb. static weight per axle at the rail.

We then have here an Atlantic type locomotive with practically the hauling capacity of a Pacific type and with a total weight about 60,000 lb. less. This saving in weight can be placed in the train and the locomotive should be capable of hauling a heavier trailing load than a Pacific type with the same size cylinders and drivers. As a matter of fact this locomotive

has shown itself to be capable of pulling an extra car on the same schedule.

In the detailed description of the construction of this locomotive which will be found elsewhere in this issue, it will be readily apparent to the locomotive designer how the result has been accomplished. Briefly, it consists of taking advantage of the very best quality of material and using it in a form which will allow the full advantage of the increased strength to be obtained.

Experience with the first experimental engine of this type indicated that it would be necessary to develop a new scheme for equalization if an easy riding locomotive was to be obtained. Steps were taken to do this and the third engine of the series, which has proved to be so completely successful, is equalized in a very unusual manner for an Atlantic type locomotive. The result has been a smooth, comfortable riding machine.

Not the least interesting feature of the locomotive is the new trailer truck that has been applied. The truck frame in this case also acts as an equalizer, a combination which has worked out very satisfactorily. It is in the form of a single large steel casting which, while massive in form and of great strength, is remarkably light. It is held from movement in a horizontal plane at the radius pin and from movement in the vertical plane at the trailer truck journal but at all other points it is permitted a combination movement either horizontally or vertically as may be necessary for the radial action or the action as an equalizer. These two movements do not interfere with each other in any way.

#### Refrigerator Car Design

An article in the issue of January 30 of the Railway Age Gazette presents some very interesting facts in connection with refrigerator cars. In recent years the railways in general have been adding very materially to their amount of equipment of this kind till at the present time they now control over 63 per cent of the refrigerator cars in operation. The tendency appears to be toward a decrease in the number of privately owned cars of this class and it is advisable for the mechanical department to extend its knowledge of the features of design that are peculiar to this class of equipment. As is pointed out in the article, refrigeration is a science which requires a certain amount of careful study if it is to be successfully applied to railway equipment. Perishable freight, if not given the proper protection and care, will produce more claims per unit of neglect than any other class of freight. A refrigerator car is a cold storage plant on wheels, but its service is such that what might be entirely practical for an ordinary cold storage plant may not be practical in a refrigerator car. Likewise, the general type of box car construction cannot be followed in all its details in the construction of these cars.

The article states that since the extra weight of refrigerator cars is carried in the superstructure, which, together with the high or suspended load usually carried, will raise the center of gravity of the car an appreciable amount, there has been at one time or another a large number of derailments. When these have occurred it has been found that they can be almost entirely overcome by decreasing the distance between the side bearings and bringing them well inside of the rails. The standard practice in this regard now seems to be about 24 in. on each side of the center of the truck, with a clearance of  $\frac{1}{4}$  in. to  $\frac{3}{8}$  in. Some car designers are strongly in favor of roller side bearings or some anti-friction arrangement which will assist the trucks in traversing curves, since the refrigerator car body is of such rigid construction that it will not ease off from the side of the truck as it strikes the elevated rail.

An excellent method of keeping refrigerator cars clean and free from permeating odors is suggested from the experience of one car company. This consists of applying two coats of hot linseed oil to the inside sheathing of the car and covering it

with a good grade of varnish. The oil will be absorbed as soon as applied, filling the pores of the wood and thereby preventing any material amount of absorption of any odors. The cars can then be kept clean with ordinary soap and water.

It is pointed out that the most vulnerable part of a refrigerator car is the insulation, and unless this is applied correctly it will very greatly decrease the efficiency of the car. An interesting test of the value the number of layers of insulation may have in a refrigerator car is reported. The purpose of this test was to determine whether or not it would be advisable to add an extra layer of insulation to some one-layer cars, and to compare the efficiency with that of a car provided with three layers of insulation. The test was a standing test and the car was empty. All four cars under test were iced at the same time with 7,300 lb. of ice and the temperatures were read on six thermometers scattered throughout the car, every four hours thereafter. A temperature of 48 deg. was maintained in the car with one layer of insulation for 18 hrs. and 30 min.; in the two-ply car it was maintained for 68 hrs., and in the three-ply car, 115 hrs. and 30 min. The ice lasted 196 hrs. in the first car; 216 in the next, and 236 hrs. in the three-layer car. Another test of the value of insulation was made on two cars, one of which had two layers of  $\frac{1}{2}$  in. Linofelt, and the other with six layers of the same insulation. These cars made a nine days' journey with an average outside temperature of 68 deg. The two-layer car consumed in this journey, 12,055 lb. of ice and the six-layer car, 8,410 lb. of ice. On arrival the temperature in the two-layer car was 42 deg., and in the six-layer car about 43 deg. This test showed that the heat transmission through the two-layer car was at the rate of 5.1 B. t. u. per square foot of exposed surface for 24 hrs. per degree of difference between the inside and outside temperatures. For the six-layer car the amount of heat transmission was only 3 B. t. u. on the same basis. The maximum variation for 24 hrs. in the six-layer car was 2 deg., and in the two-layer car it was 6 deg. These tests very clearly indicate the necessity of not only using ample insulation, but using the best quality and applying it in the best manner. The article illustrates a number of recommended arrangements for insulation applications.

### The Road Foreman of Engines

The road foreman of engines, or traveling engineer, holds a most important position as a railway officer. The nature of his duties is such that, if he is the right type of man, he can become a power in the economical operation of trains; on the other hand, if he is not the right man for the position, he may, unless he is promptly checked, cause a rapid deterioration in the quality of the service rendered by the enginemen over whom he has charge.

In an article on this subject in the Railway Age Gazette of February 6, the question of temperament is placed first as the one demanding the greatest consideration in the selection of a road foreman. The article states:

"In choosing a man from the ranks for the position of road foreman there are several things to consider. A man may have a good record as regards freedom from accidents; he may have a record for saving fuel; he may be able to get his train over the road under trying conditions; he may have an unusually thorough knowledge of the locomotive. One or more of these reasons frequently will be made the prime factor in the selection of road foremen. Without question they are matters of great importance and are to be given careful consideration in deciding on the man for the place. But should any one of them, or all of them combined, constitute the deciding factor in making the final selection? This is a weighty question, and a little study of the nature of the work may help in answering it.

"Now, the road foreman is a teacher. To be a thoroughly competent officer, he needs all the temperamental character-

istics of the most successful educator. He is placed in direct charge of the enginemen and the firemen in his district, and he has, or ought to have, charge of the selection and training of firemen. It is through his training and under his direction that these young men become enginemen, and their ability as runners depends to a great extent on the road foreman. Moreover, a considerable part of this officer's work is the conducting of investigations; and in order to properly weigh the evidence and decide with absolute fairness on the discipline necessary in such cases, he must be thoroughly capable of acting in a judicial capacity.

"Summarizing, then, the characteristics which should obtain in a man if he is to successfully fill the position of road foreman of engines: He should be of an even temperament and of a disposition which will command the friendly feeling and the respect of those under him; he should be capable of training men; and in investigations, he should be capable of getting at all the evidence, weighing it judicially, basing his decision on sound reasoning and then enforcing discipline impartially. In brief, he should combine the qualities of a student of human nature, a skilful educator and an impartial judge. He should also have a thorough knowledge of the locomotive and its efficient handling, and of course, be thoroughly acquainted with all the rules regarding the operation of trains."

Too little attention is generally given to the selecting of men for the position of firemen. There have been, of course, times when it was necessary to take almost any man who came along and applied for a place; but even at such times a better class of men could have been obtained had a competent road foreman hired the man, rather than some one totally unacquainted with the operation of locomotives. In treating this phase of the subject the article says:

"The selection and training of firemen, who are to be the future enginemen, should be given at least as much care as the selection and training of shop apprentices; and the man who understands better than anyone else the type of man that will produce the best results in this service is the road foreman. The road foreman has the chief responsibility in training the man after he is accepted, and he should personally select the material with which he has to work. The selection is too important to be settled without his aid. In order to do this intelligently he must be a student of men, their characteristics and their habits."

Good results cannot be expected from a road foreman if he is overworked. This naturally brings up the question of how much work should be assigned to a road foreman. There has seemed, in the past, to be a tendency toward placing too many crews under one foreman's supervision, and when this is done he cannot do justice to any crew. Under such circumstances he seldom rides with a crew unless so directed by his superiors because the men in question are not doing good work. In the article from which we have quoted, emphasis is laid on the success of the system, now in force on a number of roads, of requiring the road foreman to visit each of his crews once in a certain period of time, 30 days being generally fixed as the limit for this purpose. In conclusion, three principal considerations are outlined for the selection of road foremen:

"(1) Consider first the temperament of the man; his ability as an engineman and his other characteristics should be secondary to this.

"(2) Make a careful study of what it is desired to have the road foreman accomplish and with this in mind fix the extent of his work so that he can keep in close and frequent touch with every man under his jurisdiction.

"(3) Give him absolute charge of the hiring of firemen and the training of both firemen and enginemen; then hold him responsible for the development of the right kind of men.

"Finally, if a system of supervision and training of engine-



men by means of road foremen is to be a success the officer who selects the road foreman must be a man who is wholly fitted for the position he holds. It cannot be reasonably expected that a master mechanic who is narrow minded, and who looks only at today and lets tomorrow take care of itself, will have under him any but men of the same type. In the final analysis, the type of man who holds the place of road foreman depends on the type of man at the head of the organization."

### NEW BOOKS

*Kansas Fuels: Coal, Oil, Gas.* Engineering Bulletin No. 3 from the University of Kansas. Bound in paper. 6 in. x 9 in. 40 pages. Illustrated. Published by the University of Kansas, Lawrence, Kan. Copies free on request.

The heating values and proximate analyses of coal, as found in the different mines in Kansas, together with other important information concerning the mining and the general characteristics of the fuel are given in this bulletin. Similar analyses and information are also included in connection with oil and natural gas from the same regions.

*Spontaneous Combustion of Coal.* By S. W. Parr and F. W. Kressmann. Bulletin No. 46, University of Illinois. 87 pages. 6 in. x 9 in. Illustrated. Bound in paper. Published by the University, Urbana, Ill. Copies free.

In view of the fact that it is becoming quite general practice for the larger users to store quantities of fuel for the purpose of protecting themselves against labor difficulties at the mines or interference of transportation by weather conditions, a thorough investigation of the causes and prevention of spontaneous combustion is of decided value. This bulletin contains probably the most carefully prepared report on the subject that has yet appeared. In the conclusions, it lists the preventive or precautionary measures that are suggested for the prevention of spontaneous combustion, especially with bituminous coals of the Illinois type.

*Scientific Management.* Addresses and discussions presented at the First Tuck School Conference, Dartmouth College. Bound in cloth, 6 in. x 9 in., 387 pages. Published by the Weekly Bulletin Publishing Co., Boston, Mass. Price \$2.50 net.

This book contains a complete report of the conference on Scientific Management held at Dartmouth College under the auspices of the Amos Tuck School of Administration and Finance, including papers on the principles of scientific management, scientific management and the laborer, scientific management and the manager, discussions of the applicability of scientific management in certain industries, scientific management and government, and other phases of scientific management. Among the authors are included Henry B. Quinby, ex-Governor of New Hampshire; Ernest Fox Nichols, LL.D., President of Dartmouth College; Frederick W. Taylor, consulting engineer; Henry L. Gantt, consulting engineer; Harrington Emerson, consulting engineer, and other experts who are noteworthy in scientific management.

*Analyses of Coals in the United States.* By N. W. Lord. Bulletin No. 22, Department of the Interior, Bureau of Mines. In two parts. Bound in paper. 6 in. x 9 in. 1,200 pages. Illustrated. Published by the Bureau of Mines. Copies free.

This bulletin contains, in the first part, analyses which have been made by the United States Geological Survey and the National Bureau of Mines from 1904 to 1910 of over 10,000 samples of coal collected in the United States. In the second volume are full descriptions of the samples that are shown by analyses only in the first part. These descriptions have been compiled from the note books of the persons who collected the samples and present such information regarding the character of the

coal, the impurities in the beds sampled and the nature of the roof and the floor of the bed, as has a definite bearing on the significance of the analysis of the samples. They also give supplementary details as to the capacity or output of the mine, the methods used in mining, the preparation of the coal and the chief uses to which it is put. The bulletin contains chapters by J. A. Holmes, F. M. Stanton, A. B. Fieldner and Samuel Sanford.

*American Railway Master Mechanics' Association.* Proceedings of the 1913 convention. Illustrated. Bound in cloth. 856 pages, 6 in. by 9 in. Published by the Association, Joseph W. Taylor, secretary, 1112 Karpen building, Chicago, Ill. Price \$5.

The proceedings of the 1913 convention include, in addition to the full text of the reports and discussions of the various committees, a reprint of the Pennsylvania Railroad report on the tests of a superheated steam Atlantic type locomotive, which formed an appendix to the report of the committee on superheaters. This section makes the book of unusual value for reference, since the tests were most complete in every particular and contain data of great value to all locomotive designers. The volume contains the list of committees that will report at the 1914 convention as well as the usual matter included in the proceedings of the larger associations in connection with the list of members, etc.

*Master Car Builders' Association.* Proceedings of the 1913 convention. Illustrated. Bound in cloth. 1142 pages, 6 in. by 9 in. Published by the Master Car Builders' Association, Joseph W. Taylor, secretary, 1112 Karpen building, Chicago, Ill. Price \$10.

Each year the report of the proceedings of the convention of the Master Car Builders' Association has continued to grow in size, and in 1913 it reached a total of 1,142 pages in addition to 90 double page charts. This has made it advisable to publish it in two parts. Part I contains the reports of the committees at the last convention with the full discussion thereon, reports of the officers and the minutes of the meetings of the executive committee. It contains 666 pages. In Part II are the rules of interchange, the results of latter ballot and the standards and recommended practice of the association. The price has been increased from \$7.50 to \$10.00. This includes both volumes. At the 1913 convention there were reports from 29 different committees discussed in addition to three subjects for topical discussion. Many of these were of the utmost importance and value to the railways of the country. The volume contains the names of the members of the different committees which will report at the 1914 convention, as well as a full list of the members of the association with their addresses and the number of cars represented.

*Working Drawings of Machinery.* By Walter H. James and Malcolm C. McKenzie. Bound in cloth. Illustrated. 6 in. x 9 in. 140 pages. Published by John Morley & Sons, 432 Fourth avenue, New York. Price \$2.

While this book is planned especially to meet the needs of the second and third year students who are studying drawing in the department of mechanical engineering at the Massachusetts Institute of Technology, it is not by any means a text book, but rather takes the form of a treatise in the application of mechanical drawing to the describing or designing of machinery. It gives a correct conception of the character and purpose of a working drawing, exact relation between the pictorial drawing of an object and its orthographic projection, and illustrates good modern practice in methods of representation, dimensions, drafting room systems and the like. Further it explains briefly, from the standpoint of the engineer rather than from the architect's, a few of the common methods of pictorial representation, particularly of mechanical perspective. The text is clearly expressed and the illustrations are on a scale well suited to the size of the page.

## COMMUNICATIONS

### TURNING DRIVING WHEEL TIRES

HUNTINGTON, W. Va., January 16, 1914.

TO THE EDITOR:

I note in the June, 1913, issue on page 336 a record for turning driving wheel tires at the Richmond shops of the Chesapeake & Ohio, and in the December, 1913, issue, page 640, the record made at the Clifton Forge shops of the same company.

We have at the Huntington shops of the Chesapeake & Ohio one of the latest types of heavy, high duty, driving wheel lathe manufactured by the Niles-Bement-Pond Company, and of the same pattern on which the two above mentioned records were made. This machine differs, however, in the method of drive. In the other tests the machines were driven by direct current motors which give a wider variation of speed. In the test noted below the machine was driven by a 50 h. p. 440 volt 3 phase alternating current, motor at 900 r. p. m.

By careful attention to the details we turned the following set of Mallet locomotive driving wheel tires, consisting of six pairs, in a total time of 2 hr. 24 min. The depth of cut was 1/4 in. on the side, making 1/2 in. reduction in diameter. The original diameter of the tires was 56 in. They were very hard and the small reduction did not permit us to get under all of the hard spots.

Pair No.	Time Chucking. Min.	Time Finishing. Min.	Time Removing. Min.	Time. Floor to Floor. Min.	Cutting Speed. Ft. per Min.
1.....	3	18 1/2	1 1/2	23	11
2.....	3	18	2	23	11
3.....	3	23	2	28	11
4.....	3 1/2	19	1 1/2	24	11
5.....	3	20	2	25	11
6.....	3	16 1/2	1 1/2	21	11

Average time turning, 19 min. 10 sec. Average time removing from lathe, 1 min. 45 sec. Average time from floor to floor, 24 min.

H. M. BROWN  
Shop Superintendent.

### DOES THIS FIT YOUR SHOP?

NEW YORK, January 19, 1914.

TO THE EDITOR:

I have been much interested in the articles entitled, "College Men and the Railroads."

I first entered a technical college, but after a year of it, I decided that it would not help me in the mechanical department of a railroad, so I left. I am now a machinist's helper in the erecting shop of one of the largest shops in the East, and should like to know if other shops are managed the way this one is.

A locomotive comes into the shop and stripping is begun. Quite a few parts are broken or distorted by rough handling. Smaller parts, such as brackets, are thrown to the ground or into the pit. A sweeper comes along and shovels the dirt, ashes, lagging, and some of these small parts into a wheelbarrow and the contents of the latter are thrown away. Nothing would be easier than to have boxes to put the parts in. A farmer taking a machine apart knows enough to do that.

It is the same with the bolts and nuts, many of which are removed in perfect condition—they are thrown down and swept away.

Pipes, copper as well as iron, are frequently lost in the same way.

Then, when it comes to assembling the locomotive, how do they replace the missing parts—order new ones? No—send a man outside and take that part from an engine of the same class which is waiting to come into the shop. All this takes extra time. Often the part won't fit, so a man is put to work chipping and filing it—marvelous efficiency.

As to the tools, most of them are in poor condition. If a man was employed especially to keep the wrenches up to gage, to retemper chisels and repair other tools, his wages would be saved many times over.

Another thing—anyone grinds drills, chisels and lathe tools. I thought it an indisputable fact that the only economical way was to have certain men do all the grinding. Cutting tools will not work efficiently if ground with a wrong angle.

I do not say that everything is done badly, nor do I pretend to know it all, but it seems to me that in some of these practices, there is room for improvement.

HELPER.

### YOUNG VALVE GEAR

SOUTH BETHLEHEM, Pa., January 10, 1914.

TO THE EDITOR:

I noticed on page 43 of the January issue, the description of a new valve gear designed by O. W. Young, of Schenectady, N. Y. In going over this article I note that Mr. Young made a mistake in comparing his valve gear with the Walschaert. In the valve ellipses presented, Mr. Young uses a valve travel of 6 1/2 in., 1 1/2 in. lap, 1/4-in lead and 1/8-in. inside clearance on the Walschaert gear, and 8 1/2 in. travel, 1 1/4 in. lap, 3/8-in. lead and 1/4-in. inside clearance for his valve gear. He then goes on to state that his gear gives 50 per cent wider port opening at all cut-offs.

The error lies in the fact that he should have considered all things, including valve travel, lap, lead, etc., the same on both gears when making the comparison. There has been much talk in regard to patent valve gears and their nicety of steam distribution, when compared with the Walschaert gear. In actual practice, however, we do not get this nicety of steam distribution. If Mr. Young would construct valve ellipses for the Walschaert gear, and ellipses for his gear, taking the same lap, lead, valve travel, etc., in both gears, I believe he will find that the steam distribution given by his gear will not be so much better than that given by the Walschaert. Furthermore, the valve travel of 8 1/2 in. assumed by Mr. Young is, I believe, impractical, especially with the slide valve engine, for the reason that the speed of the valve would be so high that it would be a very difficult matter to lubricate the valve properly.

A. L. ROBERTS,  
Mechanical Engineer.

[Mr. Young's reply to the above criticism is given below.—Editor.]

SCHENECTADY, N. Y., January 15, 1914.

TO THE EDITOR:

The Walschaert gear is above criticism up to 6 1/2 in. valve travel with proportionate lap and lead. It is now being frequently arranged for 7 in. travel, but at the expense of very objectionable angularities.

The comparison made was between what is thought to be the fair limit of capacity of the two gears and is solely for the purpose of indicating the need of a gear that will take care of the large cylinder volumes now being used.

It shows a logical reason why the large engines do not develop a draw bar pull at high speed at all proportionate to their size, when compared with smaller engines. No special claim is made for the Young gear in the way of improved distribution when the travel, lap, lead and clearance are the same as in the Walschaert gear. The valve movement is then almost identical, but the point is made that the Young gear has capacity for greater travel without excessive angularities. This permits more lap, lead and exhaust clearance, and in consequence wider openings without change in the time of the events. Pre-admission, release and closure will take place at the same period of the stroke, but the added area will facilitate the rapid flow of larger volumes. A pair of 16 in. piston valves with their stems frequently weigh 700 pounds. A decided increase in port openings permits the use of smaller valves without decreasing the efficiency of the engine.

It is only at high speed in the running cut-off that the matter of lubrication need be considered. Is it probable that 20 per cent increase in travel will introduce additional difficulties in view of the fact that the valve will wipe a greater portion of its seat



that has been exposed to oil saturated steam? On the contrary, is it not the case that immediate relief for dry valves in practice is to drop the reverse lever a few notches for the purpose of increasing the travel? Slide valves need not be considered in this connection for that type of valve is now obsolete, when super-heat is used.

I am arguing for a gear of greater capacity than those now in use, and not especially to promote the identical gear under discussion if some other arrangement can be found that will produce equally good results.

O. W. YOUNG.

COLLEGE MEN AND THE RAILROADS

LA FAYETTE, Ind., October 18, 1913.

TO THE EDITOR:

My attention has been called to the communication in the October number of your magazine and to the editorial comment. I am naturally much interested in this discussion, as college faculties are anxious to know whatever may be lacking in the education and training of graduates and how any deficiencies may be made good.

The first purpose of every college, whether technical or non-technical, should be to send forth its graduates with minds well trained for action and with a fair equipment in general arts and sciences. Further than this, the technical institution may give some training in mechanics and engineering. It may not, however, attempt to specialize very much in the various branches of engineering without danger of weakening the fundamental courses.

Four years is not time enough in which to take the average high school graduate and make of him a mechanical or civil engineer, much less a railroad engineer. To do this successfully means the addition of one or two years to the college course and a corresponding delay in the start in a profession.

A certain amount of railroad training is given at Purdue University as an elective in the senior year and represents about a third of the time of that year in class room, drawing room and laboratory. There are such electives in the schools of civil, mechanical and electrical engineering, fitting the graduates to enter positions in the maintenance of way, motive power or electrification departments respectively. That a considerable number of Purdue graduates have continued in railway work is evidenced by the following table which shows the professions in 1911 of those who had graduated up to that time in the schools of civil, electrical and mechanical engineering. The list given represents about 95 per cent. of the living graduates from those schools:

	Civil.	Electrical.	Mechan- ical.
Banking .....	1	0	7
Bridge construction .....	31	4	3
Civic railways .....	11	42	4
Construction and contracting.....	112	13	37
Consulting work .....	19	9	8
Farming and farm products.....	12	10	17
Graduate students .....	5	3	5
Heat, light and power.....	8	57	20
In public service:			
United States .....	53	24	13
States .....	6	4	3
Cities .....	45	3	8
Other .....	10	2	2
Lawyers .....	1	8	5
Manufacturing:			
Motor .....	..	13	31
Railroad .....	..	3	23
Iron and steel .....	15	12	40
Other mechanical .....	4	14	126
Electrical .....	2	113	30
Miscellaneous .....	53	50	133
Mercantile work .....	17	45	74
Printing and writing .....	2	2	9
Real estate and insurance.....	6	2	3
Steam railroads .....	194	36	122
Teaching:			
College .....	20	28	52
High school .....	6	15	29
Telephone and telegraph.....	1	58	3
Miscellaneous .....	5	2	10
Not specified .....	10	206	13
Total .....	649	778	830

Grouping those who are directly or indirectly associated with railroad work, we have the following comparative table:

School.	Direct.		Indirect.		Total.	
	No.	Per cent.	No.	Per cent.	No.	Per cent.
Civil .....	205	31.5	107	16.5	312	48
Electrical .....	81	10.4	29	3.7	110	14.1
Mechanical .....	149	18	51	6.1	200	24.1

Note.—One-half of those listed in contracting, consulting or college teaching are considered as indirectly associated with railways. The percentages are based on the totals for each school as given in the first table.

If there should be added to the above list the names of those who are engaged in manufacturing railway equipment, the proportions would be still greater.

That there are many who fall by the wayside is undoubtedly true. In the first place, the railway apprenticeships are not always of a character to attract bright, well educated young men, and in the second place the young men themselves frequently lack stability.

I have not found apprenticeships of any sort particularly attractive to college graduates. The terms of service appear long after a four years' grind at college, and the pay is usually not as good as the graduate can get elsewhere.

Perhaps the boys are a little spoiled by the apparent over-demand for their services, but when a young man has several jobs offered him after graduation and meets the representatives of three or four manufacturing companies who wish to apprentice him, he is hardly to be blamed for over-estimating his abilities.

I agree with your correspondent that the apprentice course for graduates should not be more than two years and that pains be taken in that time to teach the apprentice what he needs to know. This will be a good investment for both the road and the man. Too often the apprentice is left to shift for himself under the grudging guidance of an indifferent foreman.

I believe the first year should be one of well-directed hard work in the shop, so as to make the student understand not only the shop work but the shop men and their point of view. The second year he should be advanced to special problems, laid out with reference to what they teach, so as to give him what he needs without waste of time. His pay should be at least equal to what his mates can command outside. Unless the railroads feel that they can do this much, it would be better to abandon the special apprenticeship. It is idle to expect to throw men in a hopper and have them come out trained engineers.

Granted, however, that the apprentice system is all that it should be and that the graduate has the opportunities he needs, he will frequently fail for lack of stability and continuity. This is illustrated by the comments of various railroad officials in letters which I have received in reply to a questionnaire which I had sent out and which invited criticism.

I believe it is the duty of railroad officials in dealing with young men to be frank with them and explain to them the nature and purpose of the novitiate, what is expected of them and what they have a right to expect. Some of the troubles alluded to have probably arisen from a misunderstanding on the part of the student.

On the other hand, I think it is the duty of college teachers to impress on their students the serious nature of a business engagement and the definite obligations of service.

The student should be made to see that training for railroad work is not a matter of months, but of years—that what he does or what he earns today is of little importance compared with the opportunities which lie in the future for those who give faithful and conscientious service.

C. H. BENJAMIN.

ELECTRIFYING RAILWAYS IN NORWAY.—In Norway the government proposes to carry out quite an extensive scheme for applying electric traction to the railways. According to an official report as to hydraulic resources, the state already owns enough water power to serve for nearly all the railways in the south and west of the country.—*Scientific American*.

# NOTABLE ATLANTIC TYPE LOCOMOTIVE

## Pennsylvania Railroad Class E6s; Heaviest Weight on Drivers and Minimum Weight of Reciprocating Parts

The most interesting and advanced locomotive design in America at the present time is an Atlantic Type locomotive developed by the Pennsylvania Railroad. This design is not only prominent for the fact that it carries a weight on drivers equal to the heaviest ever used in this country, the lightest weight of reciprocating parts of any locomotive with equal sized cylinders, the greatest capacity for sustained pull at the drawbar at high speed and similar record-breaking features, but also for the perfection and refinement of all of its details and the origination of an entirely new method of the equalizing and distributing the weight between the carrying wheels.

The high state of perfection reached in this design is the result of several years' study and experiment. The special facilities possessed by the Pennsylvania Railroad for investigating all the features of locomotive design and operation in the greatest detail have also had their effect. The position occupied by the motive power department on this road, which carries with it the full confidence of the management and hence a free hand to progress along the most advanced lines, is the

large number of the same class, which are now under construction at the Juniata shops. They are used for the heaviest class of high-speed passenger traffic, and even when compared with very large and powerful Pacific type locomotives, have been able to give a surprisingly good account of themselves. They are in many cases pulling trains with greater satisfaction than was previously obtained with Pacific types.

The total weight of the locomotive is 240,000 lb., and the weight on drivers is 133,100 lb. This apparently excessive weight on the drivers is permitted because the dynamic augments per wheel due to the counterbalance at a speed of 70 miles an hour, is less than 30 per cent of the static weight on drivers. As a result, these locomotives do not deliver as heavy a blow on the rail, nor do they have as bad an effect on the track, so far as strain is concerned, as the majority of passenger locomotives which have a weight on drivers 10,000 to 12,000 lb. less per axle. It is because of this feature that it is possible to apply the very powerful boiler that is used. It thus appears that the sustained capacity of the locomotive, which is entirely dependent



The Heaviest and Most Powerful Atlantic Type Locomotive Ever Built

principal cause that has permitted the production of this most successful locomotive.

It was in 1910 that the first step in the development was taken, and at that time a very large and powerful Atlantic type locomotive was designed and built. This was illustrated in the *American Engineer and Railroad Journal* in April, 1911, page 124. This locomotive had no super-heater, but was fitted with a brick arch and large combustion chamber. Its operation was carefully studied, tests were made with it on the locomotive testing plant at Altoona, and in 1912 a second locomotive of the same type was built. In this case, a Schmidt type of fire tube super-heater was applied, various improvements were made in the matters of weights and materials, and this locomotive was put in regular service. It was later placed on the locomotive testing plant and a most thorough and extended series of tests were undertaken. The results of these tests formed part of the report of the committee on super-heater locomotives presented at the 1913 convention of the American Railway Master Mechanics' Association. They are included in the volume of Proceedings for 1913.

On the basis of the tests and service of the two Atlantic type locomotives already mentioned, the present design was made. A few engines were built, and, after a short service had shown that the desired ends had been reached, orders were placed for a

on the boiler, is permitted by the care that has been taken in the design of the reciprocating parts to obtain the minimum weight with the great strength required for the amount of power that is transmitted from the large cylinders. The success attained in this particular is indicated by the fact that the weight of reciprocating parts on each side of the locomotives is less than 1,000 lb.

Perhaps the most striking innovation is the method of equalization. The Atlantic type has almost universally been built with an independently equalized front truck, and both pairs of drivers and the trailing truck are equalized together on each side. In this case the front truck is equalized with the front drivers, and the trailing truck with the rear pair of drivers. This gives the locomotive a condition similar to a two-truck vehicle like a car, and has made a remarkably easy riding machine, which is exceptionally free from destructive action on the tracks. At the same time the efforts towards good riding qualities have been extended to the tenders and an entirely new form of solid frame pedestal type truck has been designed for the tenders. The details of this construction will be considered later.

Heat treated alloy steel has been freely used throughout the design, and sections have been adopted which take full advantage of the increased strength of this material. The advantage



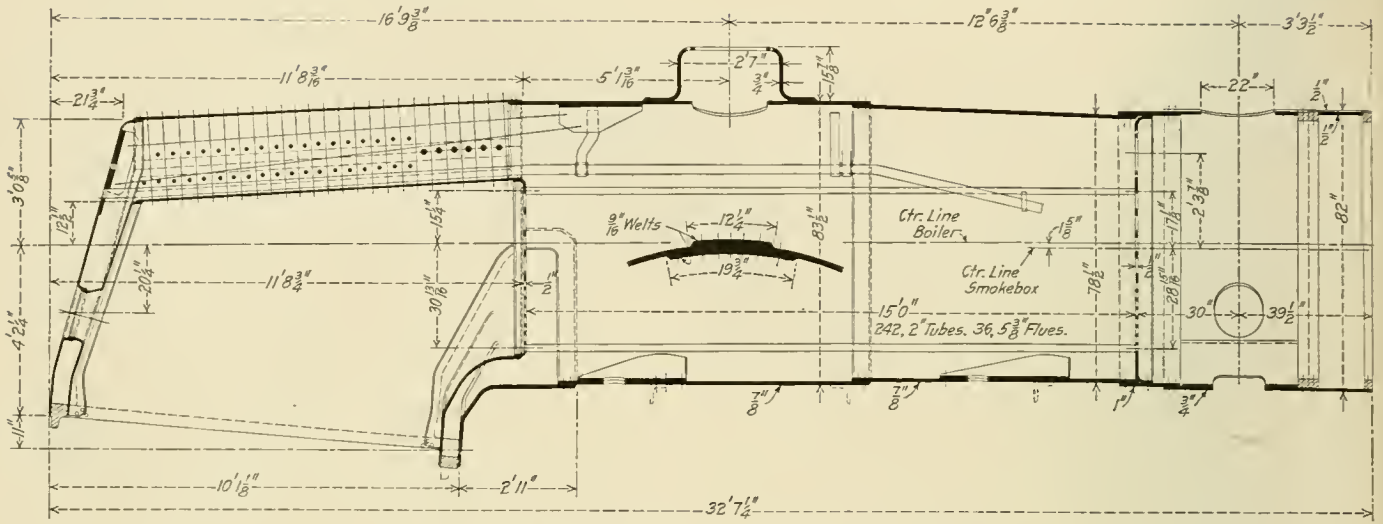

Largest Boiler Ever Applied to an Atlantic Type Locomotive

taken of the opportunity for light weight in this direction was responsible for the solution of several difficult problems.

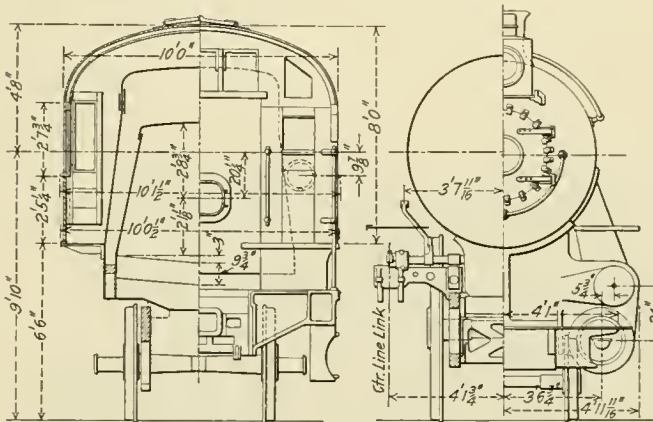

End Elevations and Sections

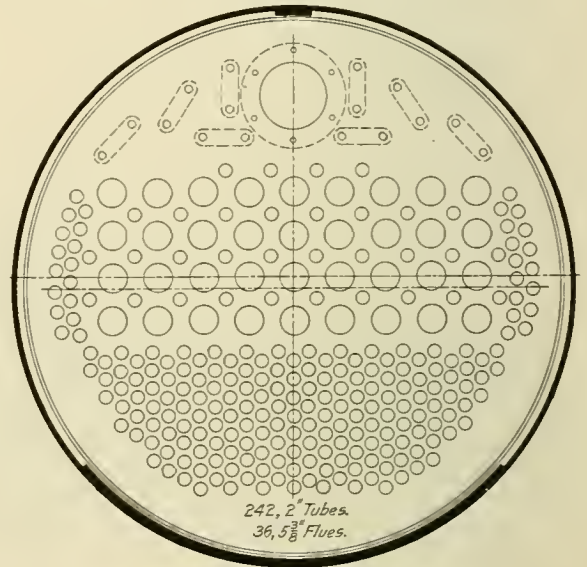

Section of the Boiler

BOILERS

One of the illustrations shows the section and also the arrangement of the tubes of the boilers. It is of the Belpaire

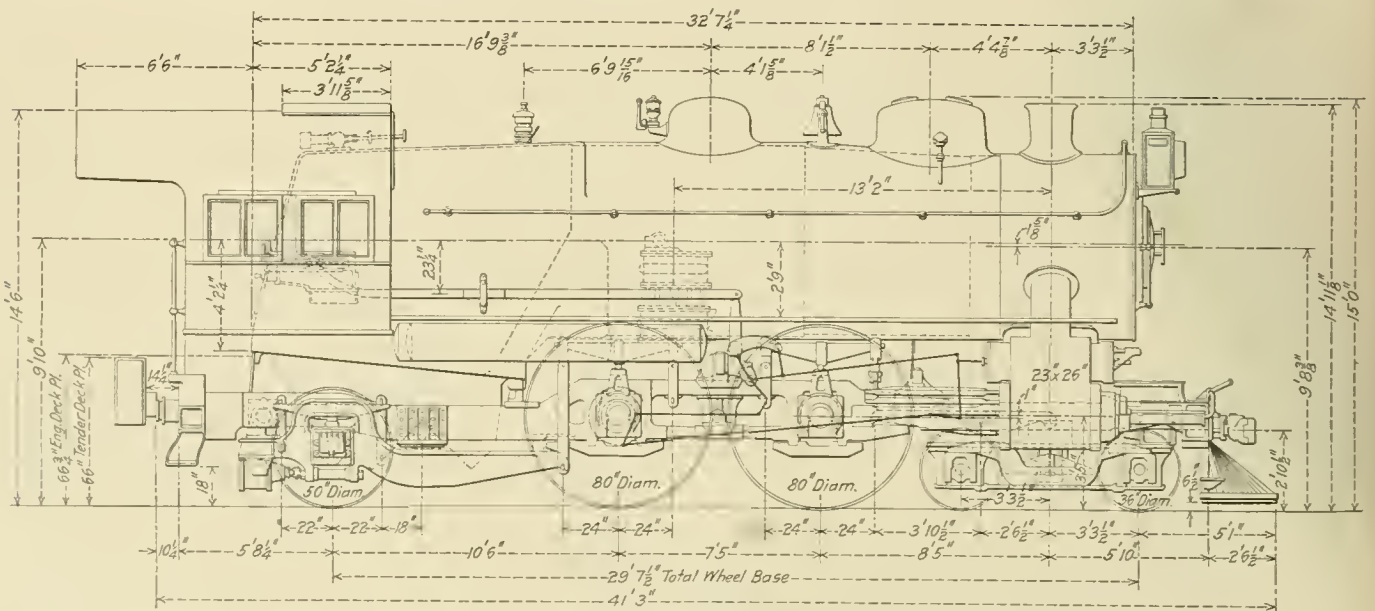

Elevation of the Pennsylvania Class E6s Atlantic Type Passenger Locomotive





increases the flamework sufficient to give very excellent combustion.

EQUALIZATION

One of the illustrations shows the detailed arrangement of the equalizers and spring rigging between the first pair of drivers

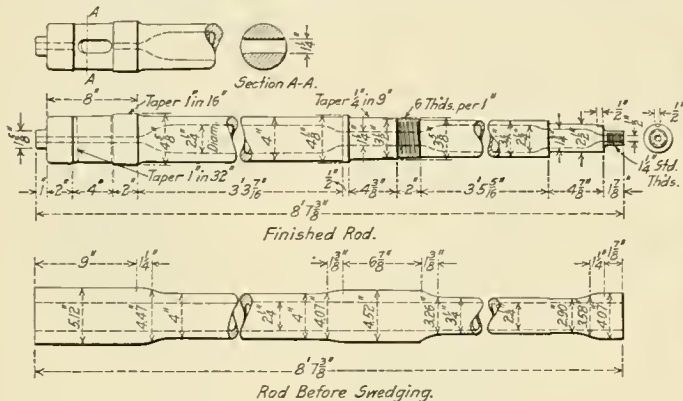

Hollow Piston Rod of Heat Treated Steel

and the engine truck. The illustration showing the details of the trailing truck illustrates the connections at the rear of the locomotive.

It will be seen that the centre plate of the four-wheeled en-

gine truck is carried by heart-shaped hangers in the usual manner, and that the center pin has taken the shape of a large diameter drum, which is inclosed on the side by the casting secured

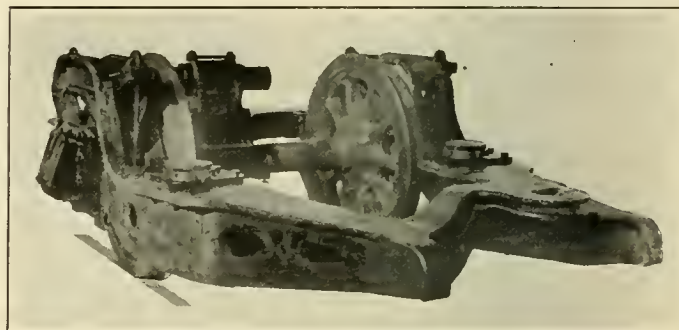

Trailer Truck for E6s Pennsylvania Locomotive

The remainder of the equalizing system is much the same as is frequently used with a two-wheeled engine truck. The details are shown in the illustration.

At the rear the trailing truck frame itself becomes the equalizer. This frame is a most substantial, carefully designed steel



Section of Hollow, Extended Piston Rod on Pennsylvania Class E6s Locomotive

gine truck is carried by heart-shaped hangers in the usual manner, and that the center pin has taken the shape of a large diameter drum, which is inclosed on the side by the casting secured

casting, all in one part, and is original in many of its conceptions. It is hinged to a frame cross brace at the center but is allowed a 3 in. vertical movement top and bottom on the pin.

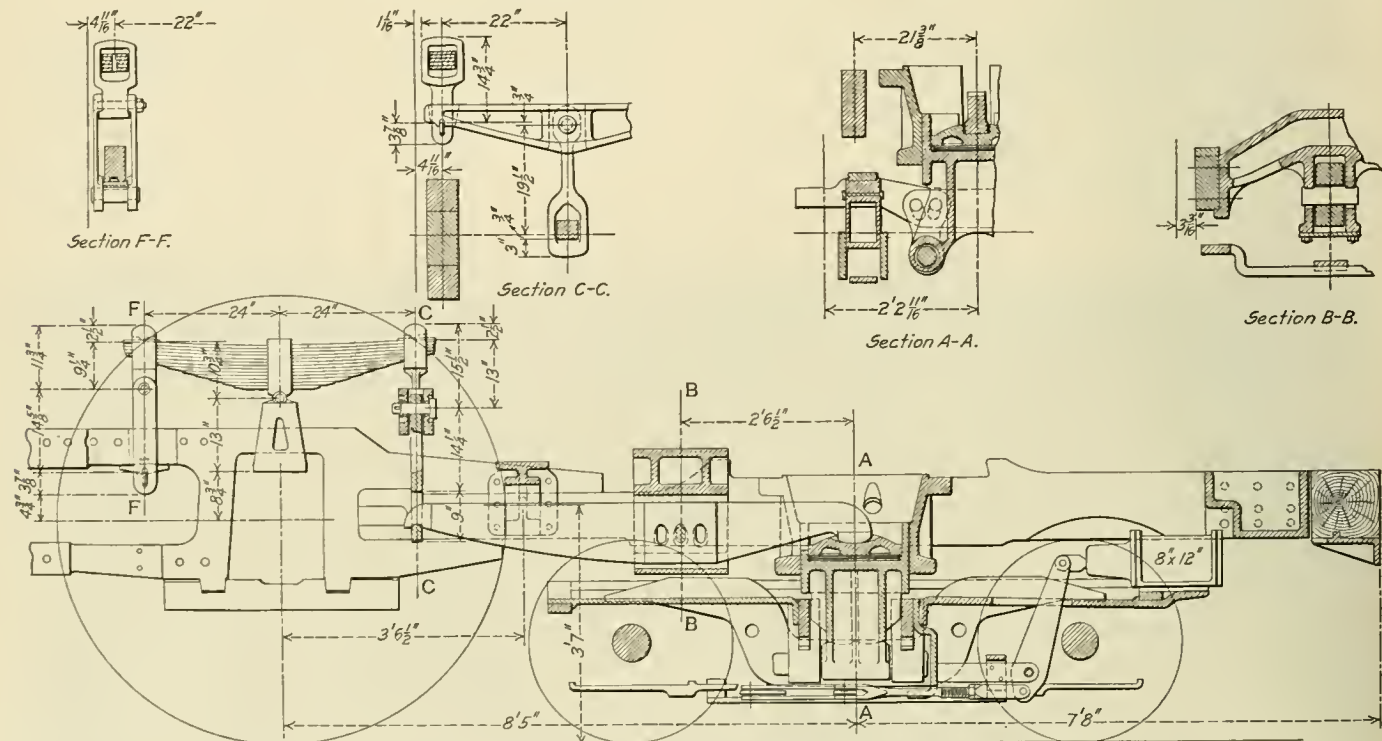

Equalization Between Front Truck and First Pair of Drivers

to the bottom of the cylinder. In the center cavity is a close-fitting, loose center plate, which rests on a lubricated face. Liners can be inserted under this plate for leveling. The top of the center plate is hollowed out, and the end of the equalizer

The location and arrangement of the combination sliding and ball and socket bearing on the bracket extending out from the trailer frame, and the arrangement of the spring over the trailing truck box are clearly shown in the illustration. The spring

centering device operates against lubricated plates on the inside of the rear frame. The bearing of the plungers on these plates is small in area, and since they are properly lubricated, this device will not interfere with the free vertical movement of the combination frame and equalizer.

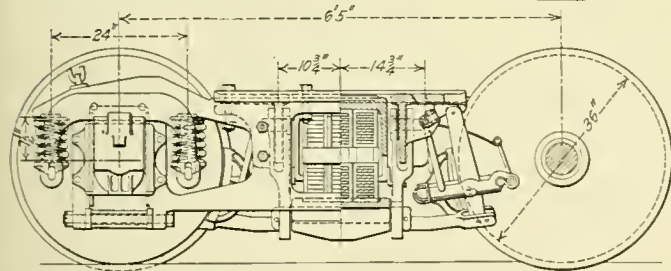
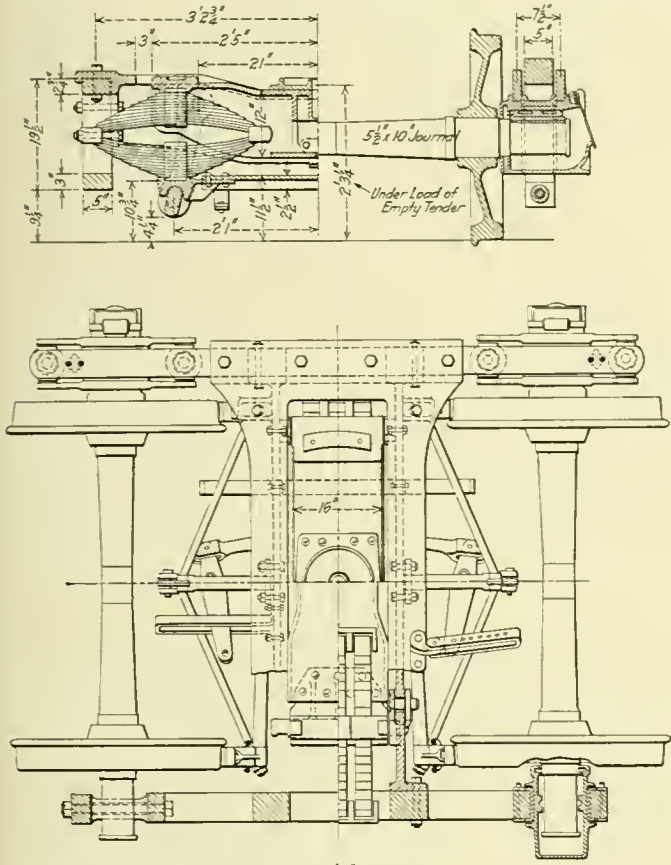

Improved Tender Truck

A very simple design of Walschaert valve gear has followed an exhaustive study of the results of tests and the best construction

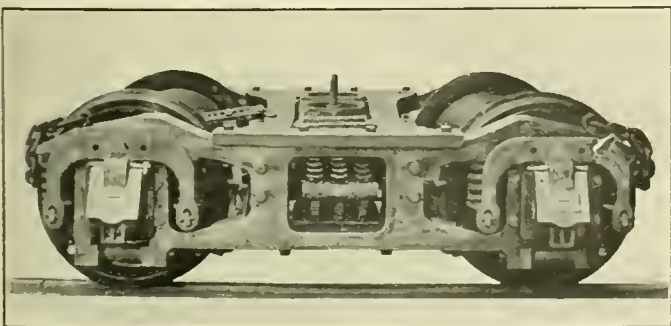

New Tender Truck on the Pennsylvania

of various details. The parts have been made as light as possible by the use of first-class materials. Two interesting features are evidenced in an inspection of the illustration, one being the use

of a fluting eccentric rod, the other the simple connection between the combination lever and the crosshead.

Much of this lightness of the valve gear parts has been permitted by the refinement in the design of the valve itself. It was realized that valves could be made much lighter than is common practice, and it was also believed that it was not necessary to have the large range of sizes so frequently found. After exhaustive tests it was shown that the piston valve could be largely standardized and that a 12 in. diameter was large enough for cylinders up to 27 in. in diameter. The standard 12 in.

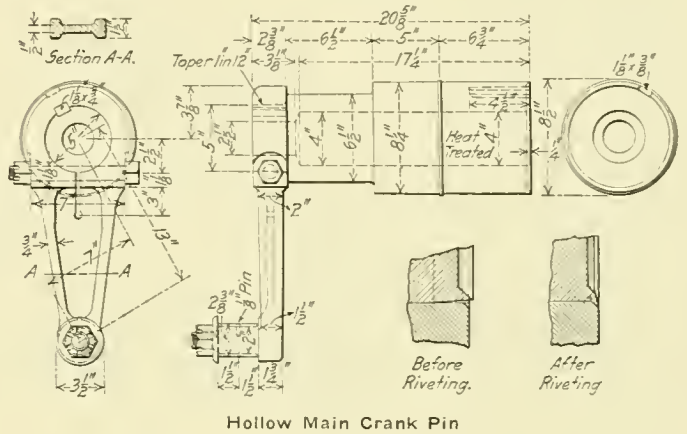

Hollow Main Crank Pin

piston valve was then developed and, with only one change in over all length, it now fits locomotives of 14 different classes on this road. The main valve on this locomotive weighs but 118 lb. The head, or followers, are of drop forged steel, while the spool, or main body of the valve, is made of a piece of seamless tubing, the ends being solid or flanged pieces of boiler steel and the parts joined by electric welding. It has snap rings of Z section and an inside lip, or flange, is arranged to prevent the displacement of parts of the ring in case of a breakage. It will be seen that the valve stem crosshead is carried in a guide that forms part of the back steam chest head.

Possibly one of the most interesting details of the locomotives

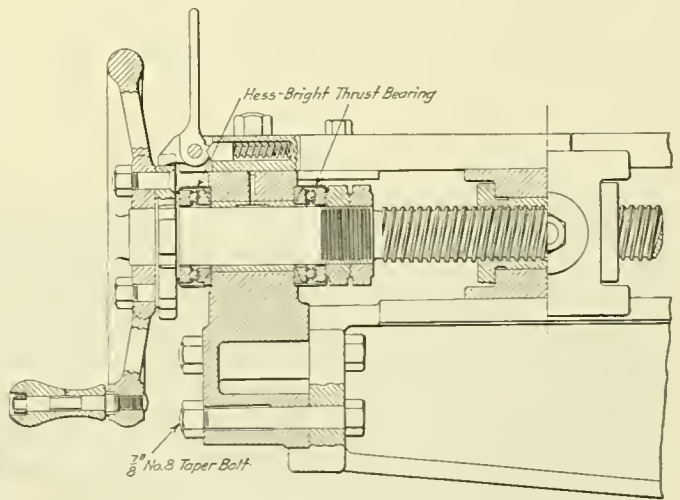

Section of Screw Reverse Gear

is the piston rod. This is of the extension type, and is of hollow, heat-treated steel. Much ingenuity was shown in working out the method of producing this unusual form of rod. One of the illustrations shows the rough forging which is drilled for its entire length of over 8 1/2 ft.

The ends of the rod and the piston fit are then pressed down to the smaller diameter in a hydraulic forging press, as is shown in the second illustration. A photograph of a section of the finished rod is impressive evidence of its lightness and strength.



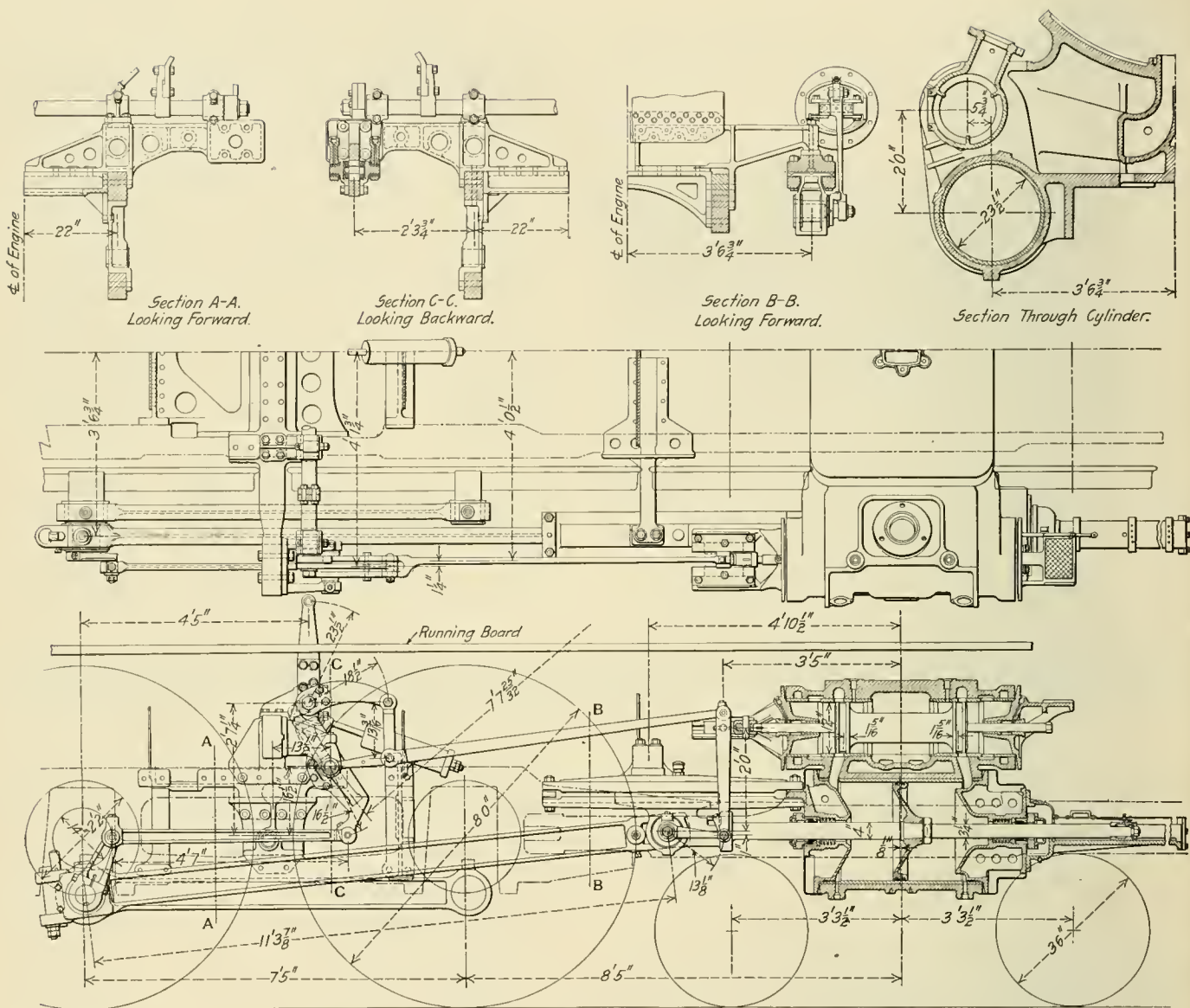

Valve Gear and Motion Work of the Pennsylvania Class E6s Locomotive

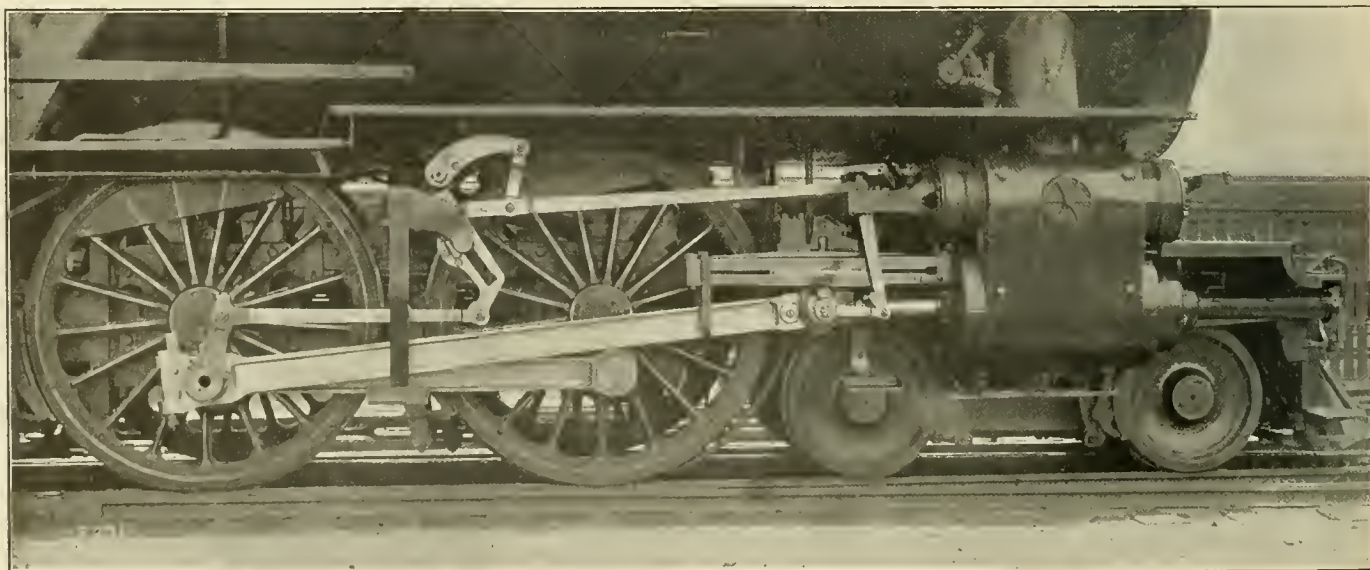

View Showing the Light Weight of the Parts of the Valve Gear and the Small Crosshead

The crosshead on the extension rod is cylindrical and arranged so that four bearings may be utilized. By removing a heavy washer and pin and turning the crosshead one-quarter of a revolution on the rod, a new surface is obtained at the bottom. The piston is a steel casting with cast iron rings. It is of the Z section and exceptionally light when its diameter is considered. The rings are joined by phosphor bronze segments, and the piston rod is locked by means of a thin plate washer, the edges of which are turned up.

When it is understood that the piston, piston rod and key complete on one side of the engine weighs but 402½ lb., it will be seen that success has been obtained in the effort towards extreme lightness.

The same care and study in the design of the crosshead has accomplished equally pleasing returns. This is probably the smallest and lightest crosshead ever applied to a locomotive of this size, and an inspection of the illustration will show its details. It will be noticed that a three-bar guide has been adopted.

An inspection of the ratios indicates that this locomotive will probably be somewhat slippery and the necessity for an easily operated and accurate adjustable reverse gear is easily understood.

The crank pins are hollow, of heat treated carbon steel, and, while the bearing surfaces are very large, the pins are light in weight. The methods of riveting over the inside of the pin after it is placed in the wheel center is shown in the illustration.

Heat-treated steel is used for the main and side rods and the axles as well as the crank pins and other parts of the motion work. Attention should be called to the exceedingly light crosshead which is carried in a three-bar guide. This crosshead is but an example of what can be done with this part when the possibilities of making it light in weight are carefully studied. The crosshead in this case with pin complete weighs but 312 lb.

TENDER TRUCK

A new form of solid frame pedestal truck has been designed for the tenders of these locomotives. This truck has a most substantial side frame which is made either of a steel casting or can be forged. A heavy cast steel transom is securely bolted to the frame. It will be noted in the illustration that each journal box has two yoke spring hangers supporting coiled springs, one on either side of the pedestal. The pedestal is provided with spool binder, and also has wearing plates, which can be removed, on either side of the jaw. This truck is, of course, considerably heavier than the usual type used under tenders, but its riding qualities are greatly improved, and its strength is beyond question.

These locomotives were designed throughout in the mechanical engineer's office at Altoona, and were built at the Juniata shop of the Pennsylvania Railroad.

The general dimensions, weight and ratios are given in the following tables:

General Data

Gage .....	4 ft. 9 in.
Service .....	Passenger
Fuel .....	Bit. coal
Tractive effort .....	29,427 lb.
Weight in working order .....	240,000 lb.
Weight on drivers .....	133,100 lb.
Weight on leading truck .....	55,000 lb.
Weight on trailing truck .....	51,900 lb.
Weight of engine and tender in working order .....	398,000 lb.
Wheel base, driving .....	7 ft. 5 in.
Wheel base, total .....	29 ft. 7½ in.
Wheel base, engine and tender .....	63 ft. 10½ in.

Ratios

Weight on drivers ÷ tractive effort .....	4.52
Total weight ÷ tractive effort .....	8.15
Tractive effort × diam. drivers ÷ heating surface* .....	599.00
Total heating surface* ÷ grate area .....	71.30
Firebox heating surface ÷ heating surface*, per cent. ....	4.93
Weight on drivers ÷ total heating surface* .....	33.80
Total weight ÷ total heating surface* .....	61.00
Volume both cylinders, cu. ft. ....	13.10
Total heating surface* ÷ vol. cylinders .....	300.00
Grate area ÷ vol. cylinders .....	4.21

Cylinders

Kind .....	Simple
Diameter and stroke .....	23½ in. x 26 in.

Valves

Kind .....	Piston
Diameter .....	12 in.
Greatest travel .....	7 in.
Outside lap .....	1 5/16 in.

Wheels

Driving, diameter over tires .....	80 in.
Driving, thickness of tires .....	4 in.
Driving journals, main, diameter and length .....	9½ in. x 13 in.
Engine truck wheels, diameter .....	36 in.
Engine truck journals .....	5½ x 10 in.
Trailing truck wheels, diameter .....	50 in.

Boiler

Style .....	Belpaire
Working pressure .....	205 lb.
Outside diameter of first ring .....	78½ in.
Firebox, length and width .....	.72 in. x 110 in.
Firebox plates, thickness .....	¾ in. & 5/16 in.
Firebox, water space .....	5 in.
Tubes, number and outside diameter .....	242—2 in.
Flues, number and outside diameter .....	36—5¾ in.
Tubes, thickness .....	¾ in.
Flues, thickness .....	1.48 in.
Tubes, length .....	15 ft.
Heating surface, tubes .....	2,660.5 sq. ft.
Heating surface, firebox .....	195.7 sq. ft.
Heating surface, total .....	2,856.2 sq. ft.
Superheater heating surface .....	721 sq. ft.
Grate area .....	55.13 sq. ft.
Dome, height above rail .....	1.80 in.
Center of boiler above rail .....	9 ft. 10 in.

Tender

Tank .....	Water bottom
Wheels, diameter .....	36 in.
Journals, diameter and length .....	5½ in. x 10 in.
Water capacity .....	7,000 gals.
Coal capacity .....	13 tons

\*Equivalent heating surface = 3,937.7 sq. ft.

## DEVELOPMENT OF YOUNG MEN IN RAILROAD WORK\*

BY GEORGE M. BASFORD

When asked to present this subject on this occasion I hesitated because to treat it in the right way puts me in the already too numerous class of critics of railroads. I decided to decline. Then it was urged upon me as a duty to help the railroads by telling the truth as I see it. With a sincere desire to show the way out of a great difficulty these observations are offered. They are offered to all the railroads of the country and not specially to those in this section. They are equally applicable to commercial and manufacturing organizations which have grown rapidly to large size and have, like railroads, neglected to provide the men of the future.

A fine orchestra is one of the best examples of successful organization. Each individual member has perfected himself in one particular part. His entire effort in life is devoted to the skillful performance of his own instrument so that it will take its place with all the others at precisely the right time, with exactly correct pitch, volume and expression. Every individual member is an artist, a master, and with his instrument he constitutes a perfect unit. Each unit is a necessary part of the whole. The omission of a single one would be detected by a competent critic. The work of such an organization is perfection itself. No one makes a mistake. Every sound goes with and into every other sound. Nothing is superfluous. There is no waste, no lost motion, no inefficiency. There is no dominant instrument. None stands out in relief against the rest. All blend into perfect music under the direction of the leader, whose slightest wish is instantly interpreted by every member. The leader is a part of every individual and every individual, in turn, is a part of the leader. This is an ideal organization.

This perfection of performance is not accidental; it is the result of unremitting training, first individual and then collective. It is worth while asking what railroad organization may learn from the orchestra. Railroads may learn from the orchestra the meaning and the importance of this word "training." If some years of study of the personnel of railroads has guided

\*From a paper read before the New England Railroad Club, January 13.



my thought correctly, railroads will find themselves unable properly to cope with their problems if they do not seriously and consistently inaugurate systems of training.

My subject is the "Development of young men for railroad service." To this should be added the same words in reverse order—"Development of railroad service for young men." I desire to present these two principles. If the best people of any kind are wanted anywhere the surroundings must be made attractive and kept so. Ask yourselves what are the inducements for your son to go into railroad service. Do you wish him to go into it? Are you doing what you may to make it attractive for him? Are you doing the right thing by the young men you now have in service? If you were to start over again, as a young man would you take up railroad work? These are pertinent questions, all of which will be readily and satisfactorily answered when the complete significance of the word training is understood and its principle is grasped and acted upon by the managements of railroads.

It is impossible to understand how the railroads of this country could have shamefully neglected apprenticeship as they have done. This is the industrial equivalent of ceasing to propagate the human race, and leaving the earth to beasts and vegetation. It will leave the mechanical trades to those who have been properly called "wreckers and rag-time mechanics." You are paying a ruinous price for this neglect today, and with worse to come if you do not wake up to the situation facing you. The few roads which are alive to it are like the taper light you carry in the Roman catacombs which makes the darkness the more impressive. What is a paltry group of twenty-five hundred boys provided with modern apprenticeship among seventeen hundred thousand men on our railroads! And yet you all take apprentices and solemnly swear that you will faithfully teach them the trades of your shops. You do not do it. You are actually dishonest with the boys. You do not even provide means for selecting them or of ascertaining whether or not they are adapted to the work you have undertaken to teach them. When they have served their time, if you give them full mechanics' wages you do it too late or too grudgingly and you promptly and properly lose the boys. The management then concludes that apprenticeship is a failure and it lapses into a dead letter. Not until self-preservation compels you will you give to the training of youth its proper place. Take warning. This point has been reached.

What training does the shop man receive today? I recently asked a railroad official how, in the absence of apprenticeship, he trained machinists. He replied—"We make them overnight from anything with two hands that comes along." It is no wonder that difficulty is found to put up a crosshead fit for a piston rod properly, or even to take one down without injuring it. It is no wonder that our locomotives carry around tons of unnecessary weight, because it is impossible for the shops to take advantage of the best engineering design. Is it possible for this railroad official to make mechanics overnight to take the places of his best men who have gone to the automobile industry? It is not and he knows it.

No matter how efficient or how well managed the mechanical department may be, no matter how well designed or how well maintained your locomotives are—the power must be used to best advantage and herein lies the field of most promise for effective training. Why not make common cause of a common problem in all departments and work it out together? Here is the greatest possible opportunity for co-operation, for a getting together, for co-ordination of effort.

Mechanical and operating officials have everything in common as a problem. Each knows much that the other needs to know. They are too far apart. I believe they may be brought together through training which will produce railroad men and not department men. What a field does the railroad present for progressive advancement and for a study of men to assure absolute certainty of advancing the men most capable of dealing

with greater responsibilities! But the promotion is not properly balanced. Who ever looks to the motive power department today for a division superintendent, a general superintendent, a purchasing officer or a general manager? The few exceptions on record simply prove the rule. Why should a mechanical department position disqualify a good man for promotion? But it does.

This is the department that brings in the money, because the locomotive earns every dollar that comes into the treasury. Furthermore, if your power is always ready for 100 per cent service, the rest of the operating problem is relatively easy. It must also be admitted that roundhouse, shop and locomotive service offer opportunities to prepare most thoroughly and most admirably for operating responsibilities. It seems fair to assume that an operating officer who first thoroughly understands the possibilities and the limitations of locomotive service and then acquires operating experience will have certain advantages over an operating officer who has grown up only in the operating line from the telegraph key or from train or yard service.

I contend that the efficient service of a master mechanic should be considered as the basis for promotion not only inside but outside of the department. In other fields a man who can maintain and operate 200 locomotives making 2,000 turntable movements every week and do this with but 1 per cent of engine failures in winter storms, would be recognized and rewarded. He has 200 individual complete power plants on wheels and scattered, to care for and keep in perfect condition. These 200 locomotives represent perhaps \$4,000,000 invested, not to mention investment in shops, coaling stations and roundhouses, and they aggregate 300,000 h. p., which is a greater aggregation of power than is concentrated in the New York Edison Waterside electric power station in New York City, the largest power plant in the world, and yet this master mechanic is likely to receive less compensation than a locomotive engineer who has a favorable run and, furthermore, he is not sufficiently encouraged by the prospect of promotion. The development of men for railroad service would be much easier if this man could be so encouraged, because it would render mechanical positions more attractive. It would cost the railroads and the public nothing to open the door for these men. A little prospect for advancement would go a long way to lead them to overlook deficiency in compensation, if compensation may not be increased.

Consider how roundhouse foremanship is misunderstood, how it is misused. Too little consideration is given to this important official, yet if he is a good one and can keep his locomotives moving under adverse conditions, for example in cold weather, he must necessarily exercise qualities of the character that make a general manager. If there is a position on the road that ought to be considered as a stepping stone to a better one it is that of the roundhouse foreman. Ask yourselves whether you would like to be a roundhouse foreman under conditions prevailing on most railroads today, with machinery, men and facilities lacking. Ask yourselves the reason. If you have ever seen a motive power officer promoted to the position of general manager you have seen roundhouses built and equipped so that men could do efficient work in them with money made thereby and you have seen good roundhouse foremen promoted. You have also seen these men give a good account of themselves. The roundhouse foreman can never have his job sweetened enough to be comfortable because of its inherent hardships, but if effective service should be recognized as a basis for promotion and the roundhouse made a stepping stone in a system of training for something better, an important part of this paper need not be written. Training must not stop with so called young men. Training, as I see it, involves the use of one position as preparation for a better one, and therefore should be an established principle in promotion.

We often hear how difficult it is to find foremen of high quality for various shops. Apprenticeship is the remedy, but not until foremanship is understood, not until the foreman is paid

at least as much as an active pieceworker in the shop. Foremanship does not attract the best shop men today.

Much complaint is heard of the difficulty in securing good firemen. Whom do you try to secure and who selects them? It was surprising to hear a railroad official make this statement before the Western Railroad Club recently: "It is too bad that in some cases men have been hired as firemen by the clerk of the road foreman. In other words, a man untrained has been permitted to select the man on whom you must depend to pull your fast trains 15 or 20 years hence." Of course this is exceptional, but that it ever occurs is important in this discussion.

An occasional strong, ambitious lad who had served his apprenticeship in the shop, would seem to be the very best candidate for this service. You would have known him for several years. The pay would attract him and he would take up the work with thorough knowledge of the locomotive which few young firemen now possess. An apprenticeship for firemen, however, is needed to take care of the other recruits for this service because comparatively few could be had from the shop boys. It is easy to imagine that a shop apprentice who becomes a fireman and then an engineman might reveal executive ability justifying his promotion to the position of traveling engineer or roundhouse foreman—but can he afford to be promoted after running an engine? We therefore see that progress here is blocked as it is for shop men as to foremanship. No one can doubt that here is something to be changed before improved methods of recruiting and training will be effective.

To return for a moment to the shop and directly to apprenticeship, ask yourselves where the boiler maker foremen and the boiler makers of the future are to be had. How many real boiler makers are you training? Boiler work constitutes the larger part of locomotive repair expense, and yet who has any boiler shop apprentices? Even the roads having the best apprenticeship schemes have very few of them. What are you doing about this to attract boys of the right sort to this vitally important trade? The right sort of boys will not take their chances in a boiler shop today. You yourselves would not. For the best of reasons you would not willingly allow your sons to do so. Look to this quickly. I warn you.

Someone asks what apprenticeship should be. The apprentice problem is very simple. For the shop it should be the old time apprenticeship brought down to date, changed and improved to meet present conditions. Several essentials must be provided.

First is the training of the hand, eye and judgment in the shop by men who have no other duties. The course should be short, active and thorough to render the boys good, quick, accurate and intelligent workmen, and good citizens, in the shortest possible time. Three years of intensive training is sufficient for the course itself. The shop training must replace the "master" of the past by a bright shop instructor who will personally teach the processes of the trade he himself commands and who will see to it that the boys of other trades are properly and consistently taught by competent men and methods. The boys must be taught direct and correct methods, and they must understand the value of time and material. This part of the subject merits a paper by itself.

Second is mental training coincident with the manual development. This means night schools or day schools conducted by men who understand the shops and who can show the boys how to educate themselves. These schools are to unfold the reasons for everything done in the shop and to lead the boys to look back at preceding processes and ahead to the processes which are to follow and to enable them to understand the materials, processes and forces with which they are dealing and to conduct their work without waste of energy, of time, or of material. Few men in the shop think of the cost of the work they do. If they did they would effect great savings. This is an important part of the school work. Boys in a year may know many things that their foreman required many years to

learn and which some foremen have never learned. For instance, our boiler shop apprentice will know how to design boiler seams. I know of a capable foreman who recently reduced the strength of a joint below safe limits believing that by putting in a surplus of rivets he had made a strong repair job.

Third and most important is the personal responsibility over the boys centering in one man, the apprentice supervisor, whose duty is to know and understand them. He must know the boys intimately, thoroughly understanding their capabilities and their personalities. He must know them better than parents usually know their boys and be able to guide them in all the affairs of young manhood. He must know them well enough to guide them into the right work, and he must have natural ability as an educator so that he can deal with each personality in accordance with its peculiar needs and its own peculiar possibilities. This man must know the essentials of the makeup of a machinist, boiler maker, pipe fitter, millwright, pattern maker, carpenter, fireman, clerk and all the rest. With this knowledge and with great care he must help the boys select their work and guide them in such changes as may be necessary. He must be able to adjust misfits which are sure to be found and must interest all the foremen in the boys. He must also be a man of high moral character, one with a personality that will enable him to influence the boys and lead them to be honorable, upright men. He must have that enthusiasm that makes work of any kind successful. He must reveal to the lads their duty to themselves and to the country. A good citizen is likely to be a good workman, and a good workman is likely to be a good citizen. You will say that these specifications are very severe and that it is difficult to find such men. The answer is that the fact that it is so difficult to find such men in itself reveals the weakness of present methods and the need for an awakening. The man who can do such work properly and who can exert this influence continuously will prove to be one of the most important subordinate officials of the whole railroad organization. A few such men are available and more are coming along.

An objector says: "We can't afford to play into the hands of the unions. Our apprentices joined the unions and we fired them." Life is too short to answer this except to ask whether anybody is seriously attempting to improve unionism. Some are saying that the labor union agreements limit the number of apprentices. The answer is that the railroads should not raise this question until they have made proper provision for the number that the agreements allow. The quickest way to increase the allowance is for a labor leader to discover that his son can not be apprenticed because the ranks are full up to the limit he himself has helped to fix. Some one else is saying that it is difficult to secure boys of the right sort in sufficient numbers. This is completely answered by the roads which have taken this subject up with serious intent. There is no trouble to find the boys. Some one will add that the red tape surrounding the employment of minors is so irksome that they cannot afford to put up with it. You will be held to account if you allow this to stop you. Another will say that small shops can not properly provide for apprentices and that poor roads can not afford apprenticeship. Both objections are absolutely silly, as has been proven by experience. You can not introduce anything in any shop or any department that will pay as big or as quick returns as will apprenticeship when it has the force of the management back of it. After the first year the boys pay back to you all you spend on their education or your system is at fault. Let me say again that failure to provide apprenticeship is not to be excused on any ground whatever.

Your office is not what it should be, neither is your shop or your drawing room if it leads to blind alleys from which there is no promotion and no outlook. You must find outlets, or the equivalent, for capable men in every department. If not outlets then you must find ways in which able men may so improve their work that they will not cease to grow, expand and become more valuable to the company and to themselves. Rail-



roads and industrial concerns are not thinking of this today!

We must take a leaf from the book of English roads. English motive power men do not quit as ours do to double their salaries in the service of industrial concerns, in positions where they are not worried to death by troubles that they know how to prevent, but are not allowed to guard against. On the larger English roads the chief mechanical officers receive salaries approximately twice as large as the largest in this country. On some English roads the chief mechanical superintendents deal not with officers who do not understand them and their problems, but with committees of the directors of the roads. No wonder those mechanical officials remain in the service until relieved upon retirement. No wonder subordinate officials are willing to spend their lives hoping to succeed to such positions.

Today the locomotive and its operation offer greater possibilities for improvement in net earnings than ever before in the history of railroads. Today the locomotive presents problems as well as possibilities requiring knowledge, experience and good judgment that were never required before. Today is the day for improvements in the use of fuel, for fuel saving devices and capacity increasing factors in locomotive design, for improvement in service and for improvement in equipment and methods for maintenance, and for the training of the men of the future. Will the railroads measure up to their opportunity? Will they? An entire evening would be required to tell of the accomplishments in improving locomotive service in spite of unfavorable conditions. What would the results have been with favorable conditions!

Apprenticeship has made good where it has had half a chance, and it has had a chance on a few progressive railroads. It is not a failure. Its value is established beyond a question. The only failure has been a lack of backing. The only trouble has been in educating the managements to what they ought themselves to know to be their duty. It is fruitless to start apprenticeship unless the very head of the organization plants himself squarely for it, insisting that every one get in line and stay there. If he does this no subordinate will dare ignore it, simply because he is looking only for the things of today. The world will not long excuse neglect of apprenticeship and that which goes with it, and this applies to every department.

**THE SINGLE-DRIVER LOCOMOTIVE.**—In spite of all that has been done in developing the locomotive on British railways there is only one type of engine which can as yet be regarded as really obsolete, viz., the single-driver passenger locomotive, the construction of which has now been entirely discontinued. The introduction of heavier and more complicated types has not, up to the present, had the effect of retiring any of those which formed the contemporaries of the single-wheeler when the latter was at the height of its popularity, although the 2-4-0, which is only one remove from the single, is no longer a type which would be built for any but the lightest service. The basic feature of coupled driving wheels in any form presents facilities for employing adhesive weight in a degree which cannot be realized where there is only one driven wheel, and this fact exercises a sufficient influence, even now, to keep many types of locomotives still within the ranks of present day standards, where they are regarded, in most cases, as being suitable, within their various scopes, for modern railway conditions. It is simply and solely this difficulty of providing adequate cohesion that has driven the single-wheeler out of favor, for there is no class of railway engine which can compare with it for economy and freedom in running. There is nothing to hinder the fitting of large boilers and cylinders to this type, but merely to provide a higher tractive effort without its being possible to utilize it without slipping the driving wheels, would serve no useful purpose and would, moreover, emphasize the need for employing coupled wheels even more decidedly than at present.

## LEHIGH VALLEY TENDER TANK

An improved construction in tender tanks has been developed by F. N. Hibbits, superintendent of motive power of the Lehigh Valley, and is now standard on that road.

The new construction comprises chiefly the use of flanges on the top and bottom sheets for the connection with the vertical

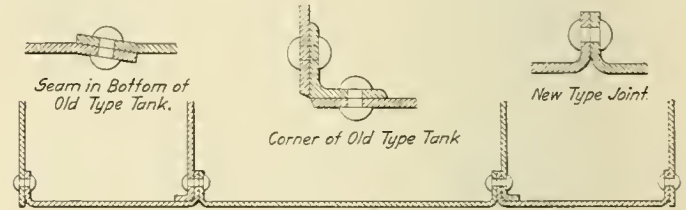

Section of New Type Tank Bottom.

Section of New Type of Tender Tank

sheets, in place of the customary angle iron. The flanges are turned into the water space and all rivets are horizontal and accessible from the interior of the tank. The new method of forming the different joints is evident in the illustrations.

This construction has proved to have a number of advantages.

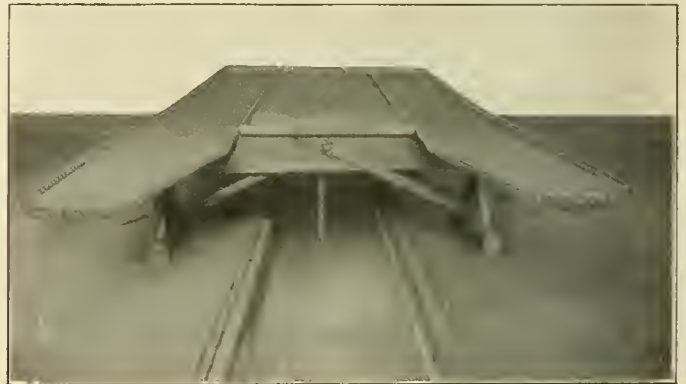

Bottom Sheets of Tank Showing Form of Flanges

In the first place, all rivets and rivet holes are eliminated from the bottom of the tank, and it is possible to remove loose rivets and tighten leaky joints without removing the tank from the underframe. Furthermore, it is found that the tank bottom has an increased life due to the absence of lap joints, angle irons and

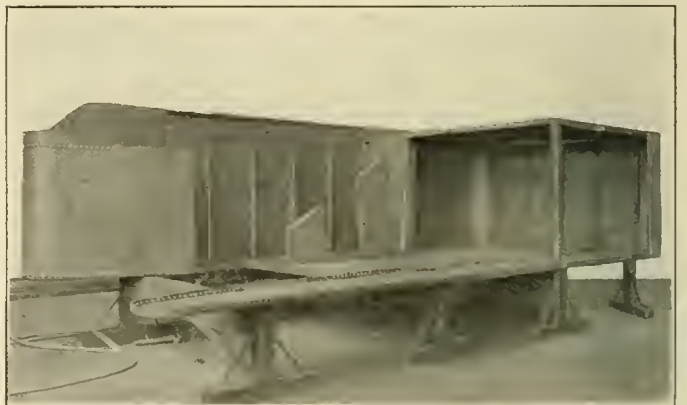

New Type of Tender Tank Partially Erected

rivet holes. The construction is stronger and simpler, and the tank is cheaper to manufacture and also gives a reduced cost for maintenance. Standard sections can be carried in stock.

The Lehigh Valley now has about 110 of these tanks in service, the first of which has been in use over two years.

# COLLEGE MEN IN RAILROAD WORK

## Discussion of Conditions That Make This Field Unattractive and Suggestions for Improvement

BY M. K. BARNUM

General Mechanical Inspector, Baltimore & Ohio

Comparatively few graduates from engineering colleges enter and continue in railroad service, especially in the mechanical department, where we would naturally expect the attractions and opportunities to be the greatest. Is the trouble with the men themselves, and their habits of mind and life? Is their college training at fault? Is it the lack of satisfactory opportunities in railroad work, or is it the experiences of other men who have tried it, that discourage them from entering railroad service?

### IS THE TROUBLE WITH THE COLLEGE MEN THEMSELVES?

College men are not inherently different from other men, but, on account of their better education, more is expected of them than of those who have had only a common school education, and properly so, but is it fair to expect that even 50 per cent. of them will be capable of holding high official positions, when less than one per cent. of other railroad men are found competent to fill such places? I maintain that it is not reasonable to expect that every college man who enters railroad service will have all of the qualifications necessary to make a first-class superintendent of motive power, when less than one in 5,000 other mechanical department men ever becomes fully qualified to fill that position, and not more than one in 1,000 ever makes a thoroughly competent master mechanic.

### IS THE TROUBLE WITH THEIR COLLEGE TRAINING?

I believe that the mechanical engineering courses in the best equipped universities, such as Cornell, Illinois, Purdue, Massachusetts Institute of Technology, Stevens' Institute, and a few others, furnish about as good preparation for railroad mechanical department work as can be desired or expected. In fact these courses provide the very best of training for such work, particularly if the student specializes in railroad subjects during the last year or two. It cannot reasonably be expected that a mechanical engineering college will turn out a graduate equipped to step into such a position as that of master mechanic, or even a foremanship, without having considerable practical experience, which can only be obtained in actual railroad service, but an engineering course will enable him to qualify much sooner for such positions than is possible for a young man who has had but a common school education and an ordinary apprenticeship. The mechanical engineering course in the above-mentioned colleges gives the student considerable practical work in the foundry, pattern making, forging, running machines, such as lathes, planers, shapers, etc., and some of them devote a good deal of attention to the principles of efficient shop management. If I were to suggest any change in the present mechanical engineering schedules, it would be that some of the higher mathematics, which are now required, should be made elective for those who wish to specialize in them, and thus allow others a little more time for such subjects as political economy, history, and possibly a short course in law pertaining to contracts and some other important items of business. These subjects would furnish fully as good mental training as the higher mathematics, and might be more useful to the average engineering graduate.

It is also important that men of practical experience in railroad and other engineering work should be secured to give lectures to the upper classes, explaining to them the advantages, possibilities and difficulties found in various lines of engineering. This plan is now followed to some extent, but a more complete and systematic program of such lectures should be provided.

Every student should also try to meet men in the lines of business which they are considering, and obtain their views and experience, but this is not always easy or possible for the student to do, especially where a college is located away from manufacturing and railroad centers.

### IS IT THE LACK OF SATISFACTORY OPPORTUNITIES IN RAILROAD WORK?

I believe that this is the principal reason why so few engineering graduates enter railroad service and continue in it. Beyond question the railroads need college trained men, because the requirements of roundhouse foremen, general foremen, master mechanics and superintendents of motive power are daily becoming more exacting and strenuous, and, to properly understand and administer the duties of those positions, a man should have more than a common school education. With the increasing necessity for making a dollar go farther than ever before, and with the constant additions of electric and other complicated apparatus to locomotives, cars and shop equipment, an engineering education is very helpful, and will soon become a necessity.

All railroads are short of material from which to make competent foremen and other officers, and yet mechanical engineering graduates are avoiding railroad service. What is the trouble? I believe that the principal reasons are these:

- (1) Advancement is slower than in commercial and manufacturing lines.
- (2) The salaries are too low in proportion to the ability and responsibility required for official positions.
- (3) The tenure of office is too uncertain on most railroads, although there are some exceptions to this rule.
- (4) There is small chance for a railroad man to accumulate any property, or to do more than make a fair living for his family and give his children an education.
- (5) There is no chance to acquire an interest in the business.

### ARE THE EXPERIENCES OF OTHERS DISCOURAGING?

Very few sons of railroad officers take up railroad work. This is due primarily to the discouraging experiences of others whose careers they have observed, but also to the advice of the fathers, who believe that the discouragements are less and the rewards for ability and industry are greater in other lines of business.

The question has been asked, "Why should it be up to a busy railroad officer to tell a college man how to start in railroad-ing?" My answer is that a part of the "busy railroad officer's" duty to his company is to secure the services of men who will become most valuable to the company, and to keep out of the service men who are not adapted to, or fit for it. How can an officer decide on a man's fitness, if he does not take the time and interest to discuss with him the opportunities and obstacles to be found in the work? Furthermore, every man, even though he be a "busy railroad officer," ought to consider it a privilege to be given an opportunity to help a young man decide on his course, and get started right in the race for success in his business career.

What are the experiences of the average mechanical engineering graduate? After spending four years in high school, and four years in college, or eight years more than the regular apprentice who has finished the graded schools, he finds himself, at the average age of 23 years, about to start work, but with very



little practical knowledge of the duties which must be performed in railroad service. Although he has had some experience in wood working, forging and machine work, he is expected to start as a special apprentice in the railroad shops at the rate of 15 or 20 cents an hour, which does not enable him to earn enough to pay his board and lodging, and is about half what he can earn in many other lines of work. But few railroads have special apprentice courses, and most of those are handled in a haphazard manner. As a rule the special apprentices are not given the proper training by the railroads to equip them for the places which are to be filled, and through which they must advance to one of the few higher positions that are really worth trying for. Sometimes they do not get fair treatment from the foremen, or even the master mechanics, and frequently the superintendent of motive power loses sight of them altogether. They are often kept on work with which they are already familiar, and not given an opportunity to learn the practical things which they must know before becoming qualified for advancement. Ordinarily, after a special apprentice has finished his three or four years' course, he is not qualified to fill the positions for which men are needed, especially those of roundhouse foremen, general foremen, etc. If the special apprentice spends two years on the right kind of work, he should be worth more than the average machinist that railroads hire when filling vacancies or increasing the force.

The special apprenticeship course should cover two years, with wages of about 25 cents an hour the first year, and 30 cents the second, although these rates might need to be increased slightly in some localities to conform with wages paid for other classes of work.

To properly qualify a special apprentice for further advancement, he should be given about the following line of work:

First year—Freight car repairs, 4 months;  
Locomotive machine shop, lathe, 4 months;  
Locomotive machine shop, planer or shaper, 4 months.  
Second year—Locomotive erecting shop, 6 months;  
Roundhouse, 3 months;  
Firing a locomotive, 3 months.

It might be found advisable to shift the order, or slightly modify the proportion of these different classes of work, but, after having the above line of experience, the young man should be qualified to work as a machinist, and within a few months should be advanced to a position as assistant roundhouse foreman, or given some similar work which will put him in line for promotion to a position as roundhouse foreman or general foreman at a small terminal.

I consider it a valuable experience to work on freight car repairs, and I do not think it necessary for the engineering graduate to work in the boiler shop or blacksmith shop, as he will be able to observe enough of the methods of doing those kinds of work, while employed in other departments, to meet his needs, although of course not enough to qualify him for a position as foreman of a blacksmith or boiler shop. It is an injustice to the special apprentice to sidetrack him in a drawing office, or to hold him for more than a very short time on test department work. The roundhouse work and firing of locomotives are especially valuable in giving him some practical knowledge of running repairs and the conditions surrounding locomotive operation.

The question has been asked, "Why should the railroad have special courses, special apprenticeships and special studentships to take care of the college men?" The railroads do not have these courses "to take care of college men," but to help qualify them to be of most use to the railroad companies. The special apprenticeship is the best means yet found of securing and preparing men with an engineering education for positions of responsibility where they are needed, and this method is all right if it is intelligently planned and followed up. To be best equipped to handle men, one must have worked in the ranks, so as to learn the difficulties and viewpoints of the man who works by the hour.

There are misfits among college men, as there are among men of other training, and when a man who has entered railroad service is found to lack the requisites for this business he should be so advised and urged to try something else before he has wasted too many years in endeavoring to learn a business for which he is not fitted.

There are many attractive things about railroad work. Its variety, the interesting problems constantly arising to be worked out, and the "things worth while" which are always waiting to be done, all form incentives to the man of active mind and body to exert his best efforts in accomplishing good results; and it is the fascination of these things which holds in railroad service so many men who might make a greater financial success in other lines of business. However, the outlook for railroad officers today is in many respects discouraging, as there is an absolute certainty ahead of much hard, nerve-racking work, long hours and government restrictions, which are daily multiplying and are at times unreasonable and difficult to comply with. All these things tend to keep many good men out of railroad work, and I predict that in five, or at most, in ten years, there will be a greater scarcity of well educated and well trained men competent to fill master mechanicships and the positions of superintendent of motive power than ever before.

## SODA ASH FEEDER FOR BOILER FEED PUMPS

In parts of the country where locomotive boiler troubles are aggravated by bad water it is also frequently necessary to provide means of introducing soda ash or some other substance in the feed water supplied to the boilers of shop power plants.

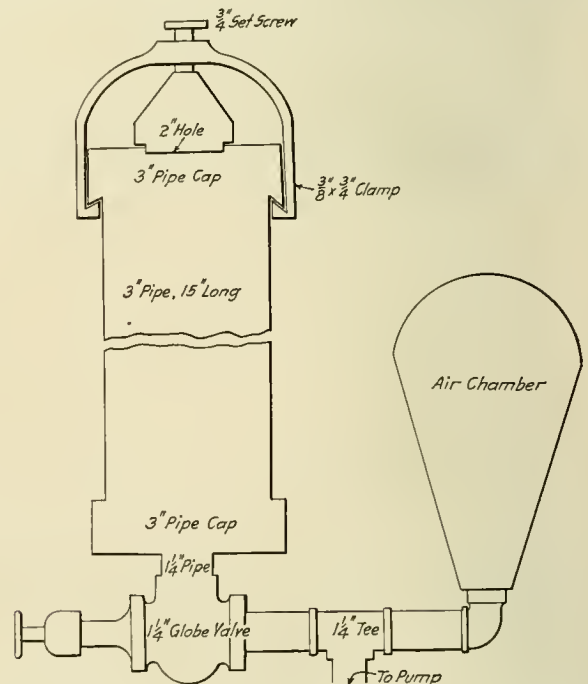

Diagrammatic Sketch of a Soda Ash Feeder for Boiler Feed Pumps

The accompanying diagrammatic sketch, which is self-explanatory, shows a device in use on a western road for passing soda ash through the feed pumps of stationary boilers. This has been in use for some time with satisfactory results.

**SPEED INDICATORS.**—In many countries in Europe all passenger locomotives are required to be equipped with speed indicators, maximum speeds being specified by law over various divisions.—*Railway News.*

# CAR DEPARTMENT

## HIGH CAPACITY WELL CAR

Three well cars which have a capacity of 220,000 lb. have been designed and built by the Lehigh Valley. They are intended to handle special shipments originating at the Bethlehem Steel Works, and are the highest capacity cars ever constructed. The

include a slightly raised cover over the draft gear, but, with this exception, the floor of the car is flat.

For a distance of about 14 ft. 8½ in. from the end sill the floor is continuous across the width of the car and the structure in this part consists of a very heavy and rigid cast steel double body bolster in two parts and 12 in. 40 lb. 1-beam center

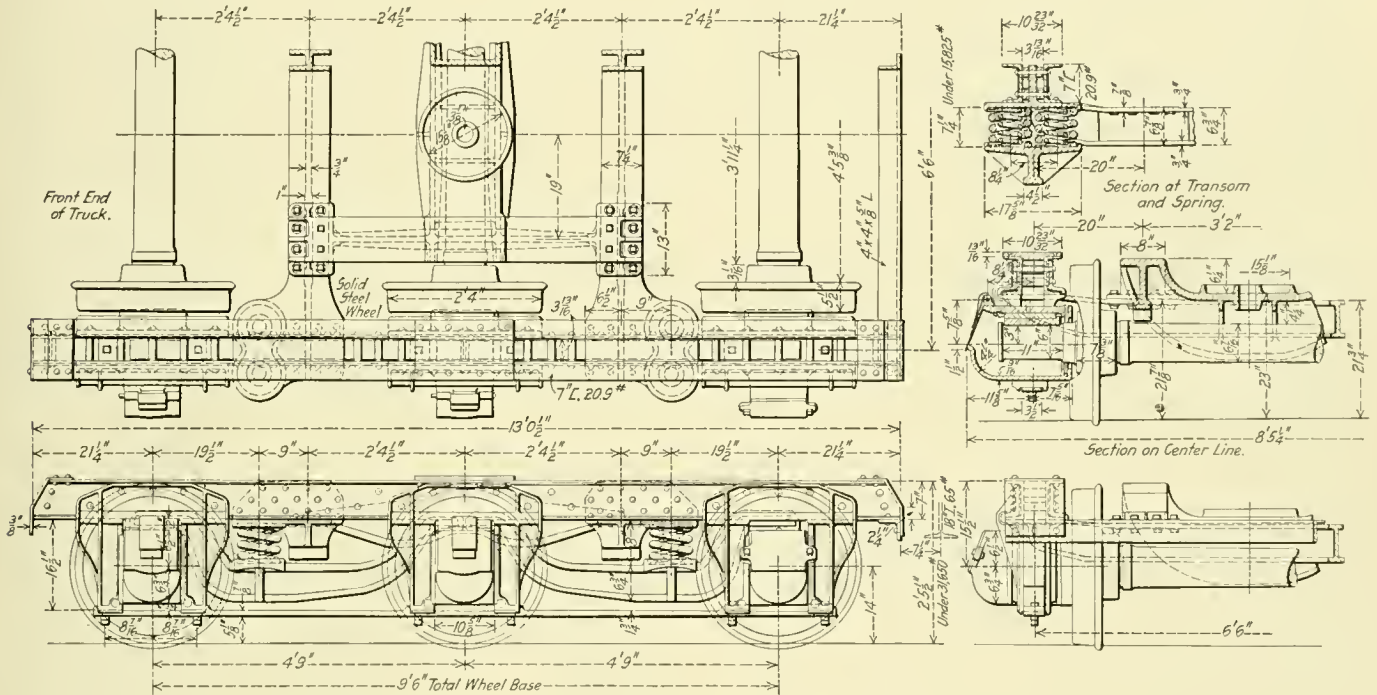

Six-Wheel Truck with 28 in. Steel Wheels for 220,000 lb. Capacity Well Car

length over end sills is 55 ft. 7¾ in., and the height of the floor above the rail level is but 38 7/16 in. It will be seen that the cars are exceptional in both of these particulars, as well as in their very high capacity. The design provides for carrying the full load concentrated at the center of the car. The well opening

sills continuous from the end sill to the end of the well opening. The sills, at the inner end, are connected to an 18 in. 65 lb. 1-beam which extends across the car in one piece between the side sills. Between this heavy cross member and the bolster there are two intermediate longitudinal sills consisting of 7 in.

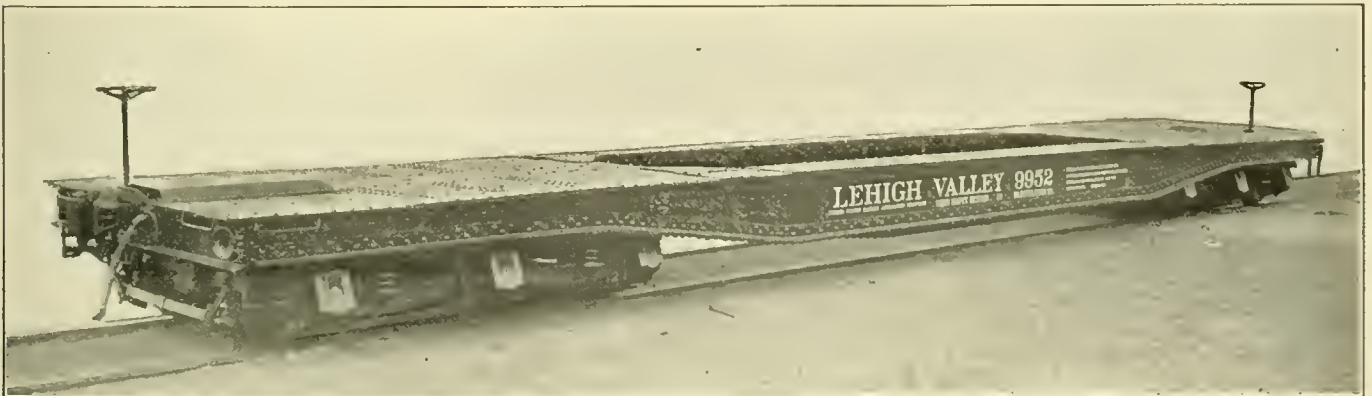

A Well Car Capable of Carrying 220,000 lb. Concentrated at the Center

is 26 ft. 2 in. in length by 6 ft. 1 in. wide and is unobstructed, except for the gusset plates at the corners.

As will be seen in the illustration, these cars are in the form of a regular flat car without pockets for side stakes and are of all-steel construction. The low floor has made it necessary to

1-beams equally spaced on either side of the center sills. This is also true of the space between the body bolster and the end sills. The arrangements and connections of these members are shown in the illustrations. The floor plates on this section of the car are 7/16 in. thick in one piece for the full width, ex-



cept over the body bolster where the plate is  $\frac{5}{8}$  in. thick. The end floor plate is, of course, cut away for the clearance of the draft gear as is shown in the illustration.

The connection in the center of the car between the two 18 in. I-beams is unusually massive and strong, since it must be capable of carry the whole load at the center if necessary. As will be seen in the cross section this consists of three plate girders on each side. The outer one is a  $\frac{9}{16}$  in. web plate, 23 in. in depth at the center and is continuous between end sills. It has two  $3\frac{1}{2}$  in. by 5 in. by  $\frac{5}{8}$  in. angles at both the top and the bottom, and in addition a  $\frac{7}{8}$  in. bottom cover plate and a double floor plate at the top. Inside of this are two girders consisting of a  $\frac{7}{16}$  in. web plate which is  $26\frac{1}{2}$  in. in depth at the center of the car and 18 in. at the connection with the cross piece. Both of these girders have a single  $3\frac{1}{2}$  in. by 5 in. by  $\frac{5}{8}$  in. angle at the top and bottom and  $\frac{7}{8}$  in. bottom cover plates. These three girders are braced and stiffened by braces about 5 ft. apart. It will be noticed that there is a  $\frac{5}{8}$  in. reinforcing plate on the inside of the side sill extending from a point about 2 ft. 6 in.

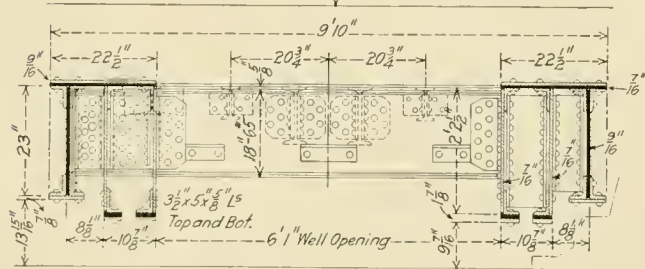
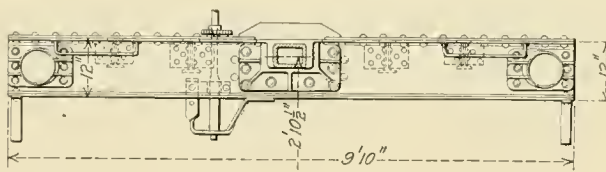
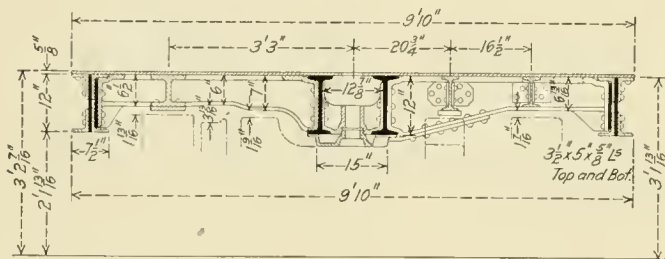

Sections of Lehigh Valley Well Car

inside of the well opening and continuous to a point about 1 ft. outside of the body bolster. This fits between the flanges of the angles on the side sills. The method of forming the connection between these various heavy members is well shown in the drawings.

In the plan view of the cars it will be noticed that provision is made for a wooden flooring which can be applied on top of the steel flooring if desired.

A desire to keep the total height of the car at the minimum distance led to the use of 28 in. solid steel wheels on the six-wheel trucks. The axles have 6 in. by 11 in. journals, and the arrangement of the framing is clearly shown in the illustration of the truck. It will be seen that it has been possible to obtain a center plate which is but 23 in. above the level of the rail by carrying the deep flanges of the truck bolster down on either side of the center axle.

This car has a total weight of 91,900 lb., and was designed in the mechanical engineer's office of the Lehigh Valley, under the direction of F. N. Hibbets, superintendent of motive power.

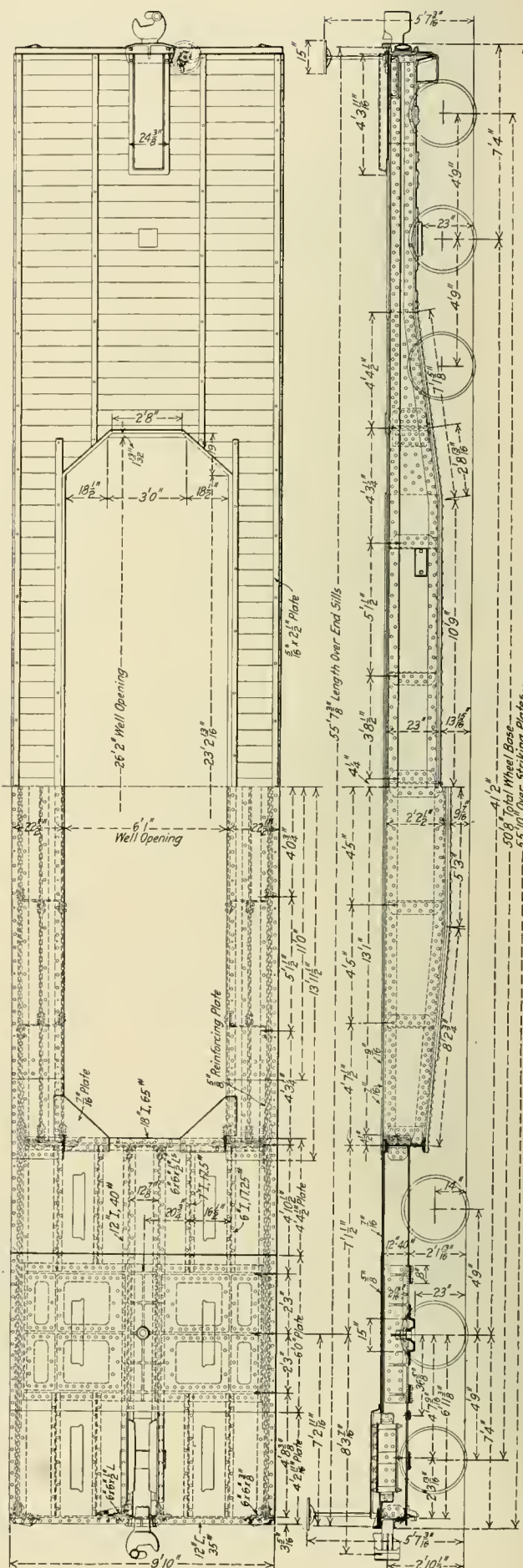

Plan and Sections of a Well Car with a Capacity of 220,000 lb.; Lehigh Valley

# DINING CARS FOR THE BURLINGTON

The First Cars of a Design That Has Been Made Standard on the Chicago, Burlington & Quincy

With the government specifications for postal cars as a basis, the Chicago, Burlington & Quincy has drawn up specifications for all types of cars to be used in passenger train service. An effort has been made to have them as simple as possible and to establish standards that will provide the greatest interchangeability between all passenger train cars. All of the designs are, as far as possible, made up of structural shapes, and all special parts, such as pressed steel shapes, are made from standard dies so that when once designed they may have a wide range of use. A special effort has been made to eliminate the use of patented constructions so that the cost of royalties will be small.

The first cars built under these new specifications are the diners that have recently been furnished the road by the Pull-

man Company. by 2 ft. 4 in. wide extending from end sill to end sill, and a bottom cover plate  $\frac{5}{8}$  in. by 2 ft., which only extends between the body bolsters. Both cover plates are riveted to the flanges of the center sills with  $\frac{3}{4}$  in. rivets spaced 4 in. apart. There are four cross bearers spaced 10 ft.  $7\frac{1}{2}$  in. apart in the central portion of the underframe. They are made up of two pressed steel pans placed back to back and riveted together. Each cross bearer is thus made up of four pressed steel pans, two of which extend from the center sills to each side sill, being riveted to the center sill by eight  $\frac{3}{4}$  in. rivets, and to the side sill by four  $\frac{3}{4}$  in. rivets. The outside ends are shaped to conform to the shape of the side sill. The top cover plates are  $\frac{1}{4}$  in. by 12 in., and extend from side sill to side sill, being riveted to the flanges of the steel pressings by  $\frac{3}{4}$  in. rivets spaced  $3\frac{3}{4}$  in

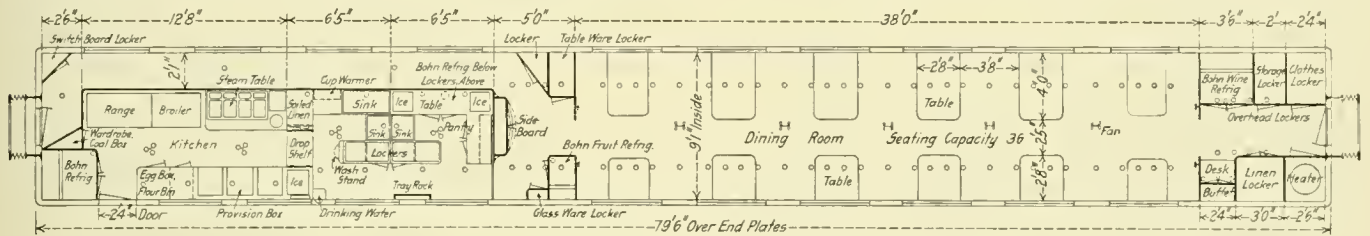

Floor Plan of the Burlington Dining Car

man Company. These cars are 79 ft. 6 in. long over end sills and have no platforms at either end. By adopting this plan it has been possible to provide seating accommodation for 36 persons and to have a larger and more convenient kitchen. A side door 2 ft. 4 in. wide, opening directly into the kitchen, has been provided so that the car may easily be provisioned. The kitchen has been laid out according to the standard practice of the Pennsylvania Lines and is provided with all the latest improvements. The cars are of all steel construction, wood being used only in and about the windows, and in the flooring.

## UNDERFRAME

The entire load between the bolsters is carried by the side construction, leaving the center sills to take care of the buffing

apart; the bottom cover plates are  $\frac{7}{16}$  in. thick and 12 in. wide at the center sills and gradually tapering to 7 in. at the side sills. They also extend in one piece from one side sill to the other.

The double body bolsters have cast steel center fillers and are riveted between the center sill channels by  $\frac{3}{4}$  in. rivets. They are located 10 ft.  $8\frac{1}{4}$  in. from the end sills. They have top cover plates 6 ft. by  $\frac{1}{4}$  in., continuous between the side sills, and are further braced by an 8 in., 18 lb. I-beam extending between them 3 ft.  $9\frac{1}{2}$  in. each side of the center of the car. There are ten 3 in. 6 lb. channels extending out from the web of the center sill to the side sill on each side of the car. They form the intermediate supports for the floor and the various equipment applied under the car.

The side sills are made up of 4 in., 8.2 lb. Z-bars, and extend



New Standard Dining Car for the Chicago, Burlington & Quincy

and draft strains. To do this the cross bearers were made sufficiently stiff to transmit any load coming on the center sills to the sides of the car. The underframe is of simple construction and is made up mostly of steel shapes. All the pressed steel work serving similar purposes is made from one die and therefore at a minimum expense.

The center sills are composed of two 15 in. 35 lb. channels spaced 16 in. apart. They have a top cover plate  $\frac{5}{16}$  in. thick

the full length of the car, being riveted to the cross bearers by four  $\frac{3}{4}$  in. rivets and thoroughly anchored in the end sills by angle gusset plates. The end braces are made of  $\frac{3}{8}$  in. plate being pressed to the shape of a channel 9 in. wide and flanged out at the ends to make the connections at the corner posts and at the junction of the center sills with the cross bearers.

The end sill is made up entirely of pressed steel shapes and steel plates. A pressed angle  $2\frac{1}{2}$  in. by  $4\frac{1}{2}$  in. by  $\frac{3}{16}$  in. ex-



tends across the end of the car being riveted to the end bracing, the small pressed steel Z-floor beams and the center sills. A 3/16 in. plate 10 3/4 in. wide is riveted between this angle and a pressed shape made of 3/8 in. plate, and extends

extends clear across the end of the car while the pressed steel shapes only extend between the corner posts and two vertical I-beams located 21 1/2 in. each side of the center line of the car

These I-beams are the point of greatest resistance in the end

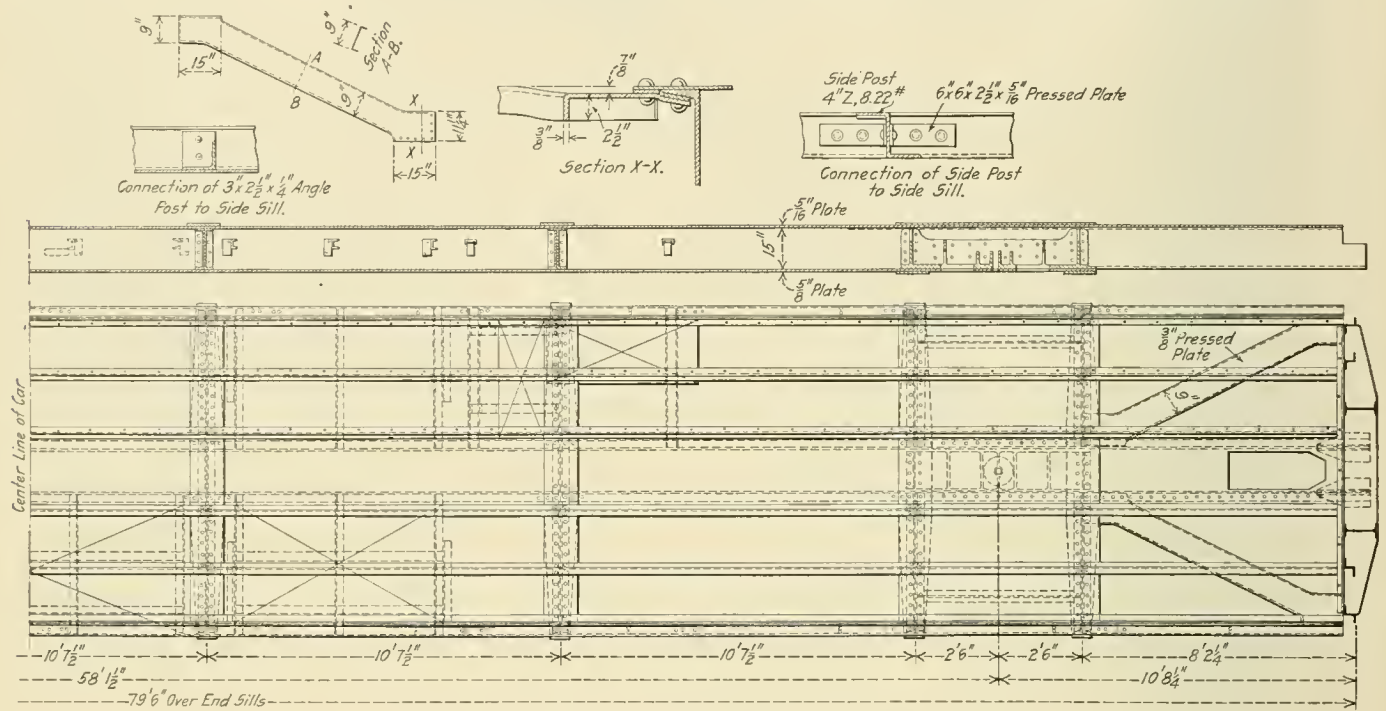

Underframe and Details of the New Diners for the Burlington

down to the bottom of the end sill. A second pressed shape of the same stock is located below the first and is riveted to the lower part of the 3/16 in. plate. A 1/2 in. by 6 1/2 in. end sill cover plate is riveted to the outside face of these shapes and

construction of the car, being 12 in. wide and weighing 31.5 lb. per foot. They are thoroughly anchored in the end sill and extend from the bottom of the end sill to the end plate at the roof, where they are again anchored in the superstructure.



Interior View of the Burlington Dining Car Taken by the Light from the Indirect Lighting System

Further bracing of the car end is provided by two 4 in. 13.8 lb. Z-bars located 15 7/16 in. each side of these I-beams, and by the 4 in. 8.2 lb. Z-bars which form the corner posts. These Z-bars are anchored to the end sill at the top of the upper pressed

and dimensions. The side posts are continuous from the side sill to the side plate, being secured to the side sills by two 6 in. by 6 in. by 5/16 in. angles, and to the side plate by 3/16 in. gusset plates. The belt rail is made in sections extending between the side posts and secured to them by 4 in. by 4 in. by 5/16 in. by 2 in. angles above and below. There are ten 3 in.

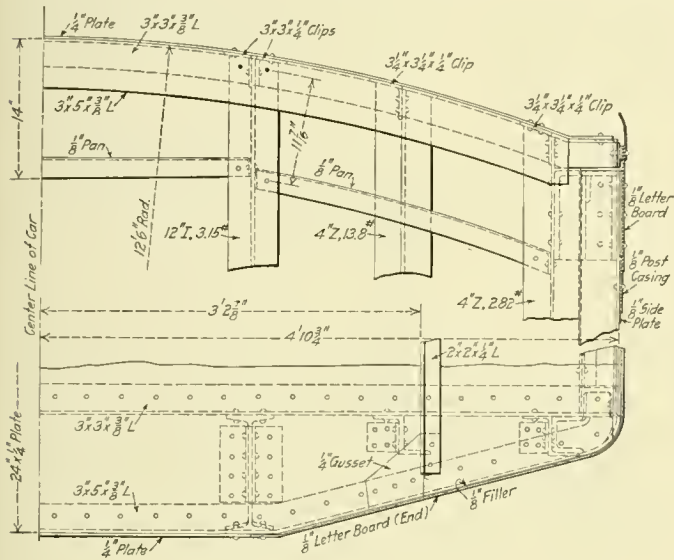

Roof Details at the End of the Car

steel shape by angle plates. This construction provides a section modulus of 72 in contrast to the government requirements of 65 for mail cars. This end is of a standard design and is

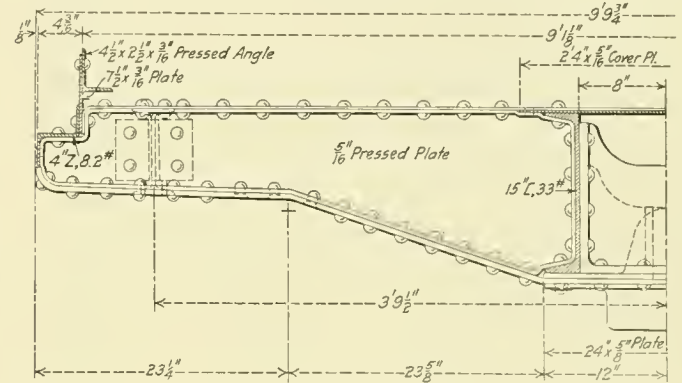

Steel Pressings Are Used in the Construction of the Double Body Bolster

by 2 1/2 in. by 1/4 in. angle window posts on one side of the car and eleven on the opposite side, which extend from the belt rail to the side plate. The posts for the side door in the kitchen are made of 4 in., 8.2 lb. Z-bars. The side framing below the belt rail is stiffened with 3 in. by 2 1/2 in. by 1/4 in. angles.

There are 52 carlines for the lower deck and 26 for the upper

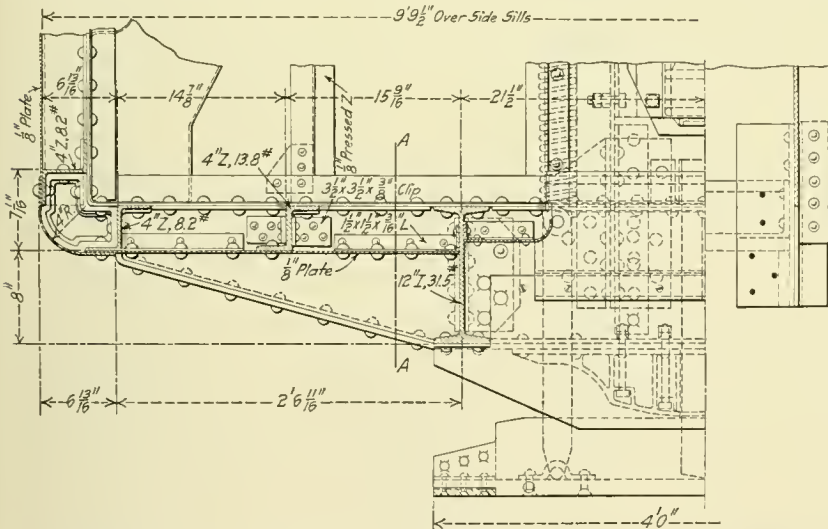

Construction at the End Sill of the Burlington Dining Car

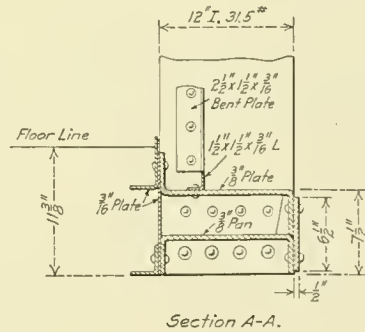

Section A-A.

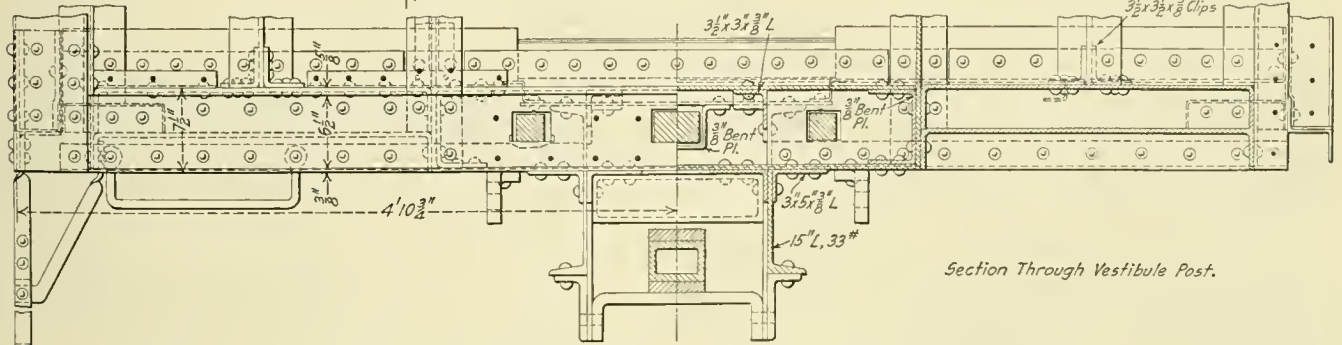

Section Through Vestibule Post.

intended to be used in all passenger equipment, even though built with a platform.

BODY FRAMING

The side framing of the cars is made up of eleven 4 in., 8.2 lb. Z-bar posts, and a belt rail and side plate of the same shape

deck, both of which are made of pressed steel shaped in the form of a channel. The lower deck carlines extend from the side plate to an equal number of pressed steel deck posts, also shaped in the form of a channel, which serve as a tie between the upper and lower carlines. The roof joint carlines are 2 1/2



in. by 1 1/4 in. 2.9 lb. T bars, the joints between the roof sheets being welded by the oxy-acetylene process. The deck plates and moldings are all of steel.

FLOOR

The floor is supported by a 4 1/2 in. by 2 1/2 in. by 3/16 in. pressed angle on each side of the car, which is riveted to a 7 1/2 in. by 3/16 in. base plate, that extends along the side of the car and is riveted to the inside face of the upper leg of the Z-bar side sill, and by four 1 13/16 in. pressed Z-bars extending the full length of the car and riveted to the 3 in. channels that extend from the center sill channel to the side sills, there being ten of these channels on each side of the car. To these supports is riveted a No. 16 gage galvanized corrugated steel plate on which is laid a 1 1/4 in. layer of carbolith which is held in place by chicken netting fastened to the corrugated plate. Next is a layer of 1 in. hair felt. The finished flooring is laid with 2 1/4 in. by 3/4 in. tongue and groove maple which is nailed to nailing strips laid in the carbolith and bolted to the corrugated plate. The maple floor is underlined with waterproof paper and held 1/2 in. above the hair felt to provide an air space.

SHEATHING

The outside sheathing is 1/8 in. steel plate on the inside of which is applied a layer of three-ply Salamander. The inside sheathing is 1/16 in. steel plate and is lined with Ceilinite 3/16 in. thick. The outside sheathing is riveted directly to the side posts and the belt rail, a belt rail plate 3 in. by 1/8 in. being applied on the outside for a finish. The inside sheathing, however, has the Ceilinite extending between it and the side posts and belt rail. The letter board is a 1/4 in. plate 12 11/16 in. wide, being riveted to the side sheathing and directly to the side plate with the lower deck roofing. The lower deck is roofed with No. 16 gage steel plate and the upper deck with No. 14 gage steel plate both having an inside layer of three-ply Salamander for insulation. The headlining is No. 22 gage steel sheets and is also lined with 3/16 in. Ceilinite. The Salamander is also applied to the car ends and is held in place with fireproof glue and pressed galvanized iron channels whose ends are turned against the posts and bolted. The Ceilinite on the inside of the finished plates is secured in the same manner.

OTHER DETAILS

The cars are lighted by the indirect lighting system as applied by the Central Electric Company, Chicago. The lamps and reflectors are located in the deck molding at the top of the lower deck and are so arranged as to be inconspicuous from the floor. There are 74 15-watt, 60-volt lamps used in the dining room proper and the vestibule. These are arranged in 4 ft. units containing four lamps each and 1 ft. units containing one lamp each. There are six 4 ft. unit sections placed one each side of the car and the 1 ft. units are placed between the deck beams to keep the car ceiling lighted at an equal intensity. The reflector is made of No. 20 gage steel and is covered with three coats of fired cream enamel, this color being also used on the upper ceiling. The lamps are so set in the reflector that the bases will not come within the area of the reflectors, in this way eliminating the absorption of light by the sockets. The reflectors are covered with a double layer of glass placed on an angle to minimize the collection of dust. The two layers of glass are used to prevent dust or dirt getting into the reflector. The four units are so wired that one lamp may be cut out as desired and thereby regulate the amount of light required. The total current consumption for the car is 18 1/2 ampere hours. The average lighting intensity throughout the car on a plane 30 in. from the floor is 3.91 foot candles. That an abundance of light is provided is incicated by the interior photograph taken by the artificial illumination.

The cars are finished in a pleasing mottled gray color with gold striping on the headlining. The wood used in and about

the windows is Mexican mahogany. The chairs are also of mahogany with Spanish leather covering. The dining tables are made of steel; six of them are 2 ft. 8 in. by 2 ft. 8 in. and six 2 ft. 8 in. by 4 ft. They are covered with white metal. Wall sockets are applied under the windows and just below the tables for electric table lamps. The Commonwealth Steel Company's cast steel six-wheel trucks were applied. The various specialties used

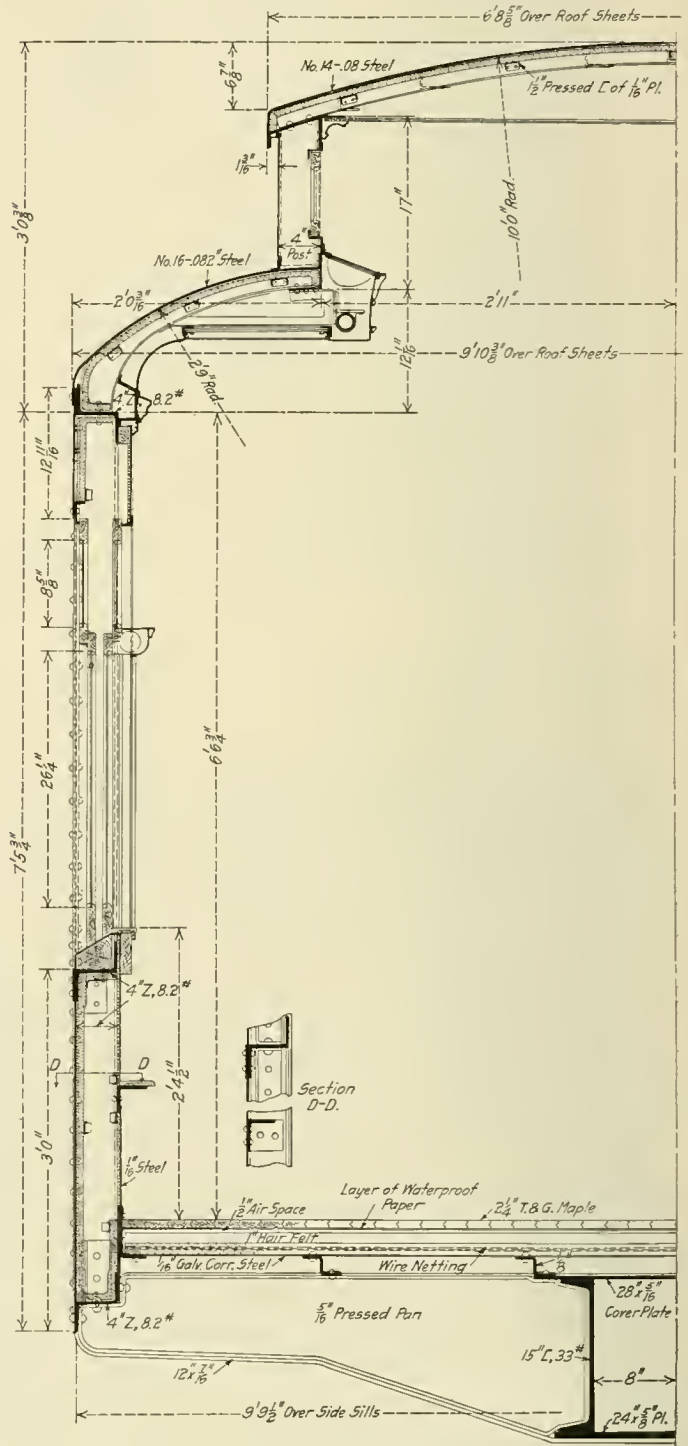

Cross Section Through the Burlington Diner

were the Miner friction draft gear class A-2-F, Sharon couplers, Woods roller side bearings, Vulcan 60,000 lb. capacity cast steel brake beams, McCord journal boxes, Christie adjustable brake heads, Westinghouse latest improved air brakes with the American slack adjuster, Railway Utility Company's ventilators, Bohn

refrigerators, and 32 Willard storage battery cells, type P. R. L. The following are the general dimensions of the cars:

Length over end sills.....	79 ft. 6 in.
Width over side sills.....	9 ft. 9½ in.
Width over all at the eaves.....	9 ft. 9¾ in.
Width over clearstory.....	6 ft. 8¾ in.
Top of rail to top of floor.....	4 ft. 6 7/16 in.
Top of rail to top of buffer beam.....	4 ft. 2¾ in.
Wheel base of truck.....	5 in. x 9 in.
Journals.....	40¼ in. (steel tired)
Wheel centers.....	34 in. (steel plate)

## GRAIN TIGHT CONSTRUCTION FOR SINGLE SHEATHED BOX CARS

BY W. J. TOLLERTON

General Mechanical Superintendent, Rock Island Lines, Chicago, Ill.

Perhaps one of the most discussed subjects appearing in the technical press today is the proper design of freight car equipment. From this fact it can readily be assumed that the mechanical men on our railroads are given much attention to the problem in order to make more efficient designs to meet the present day requirements. It is felt that cars must be kept more off the repair tracks and more in revenue service, and while in actual service they should meet all requirements. Less equipment will, therefore, naturally be required if the designs are prop-

as its weakest link. Cars of this design have been assigned to automobile service, and complaints have been filed relative to the double-decking of automobiles, the claim being made that the single sheathing did not furnish the proper thickness of material to which to spike the temporary framing for securing the upper tier of machines. When nails are used they pass through the sheathing and project from the outside, giving a very bad appearance, as well as destroying the sheathing. Some arrangements to overcome this have been developed and are now being tried out. Some roads are running three or four girth boards along the inside of the car, which are bolted to the side sheathing. This with the sheathing gives an ample thickness to which to nail. Other roads are using pockets secured in the side sheathing in which cross stringers are placed for the support of the upper deck of automobiles.

The lumber in the single sheathed car must be properly kiln dried, or openings between the boards will soon show up, necessitating taking the car in on the repair track and again closing them.

Much trouble was experienced along this line with the first cars of this design, but kiln drying the lumber has eliminated at least a part of this trouble. This has, however, increased the cost of the car, inasmuch as it makes extra labor and extra shop equipment necessary.

The connection between the side sheathing and the floor, in

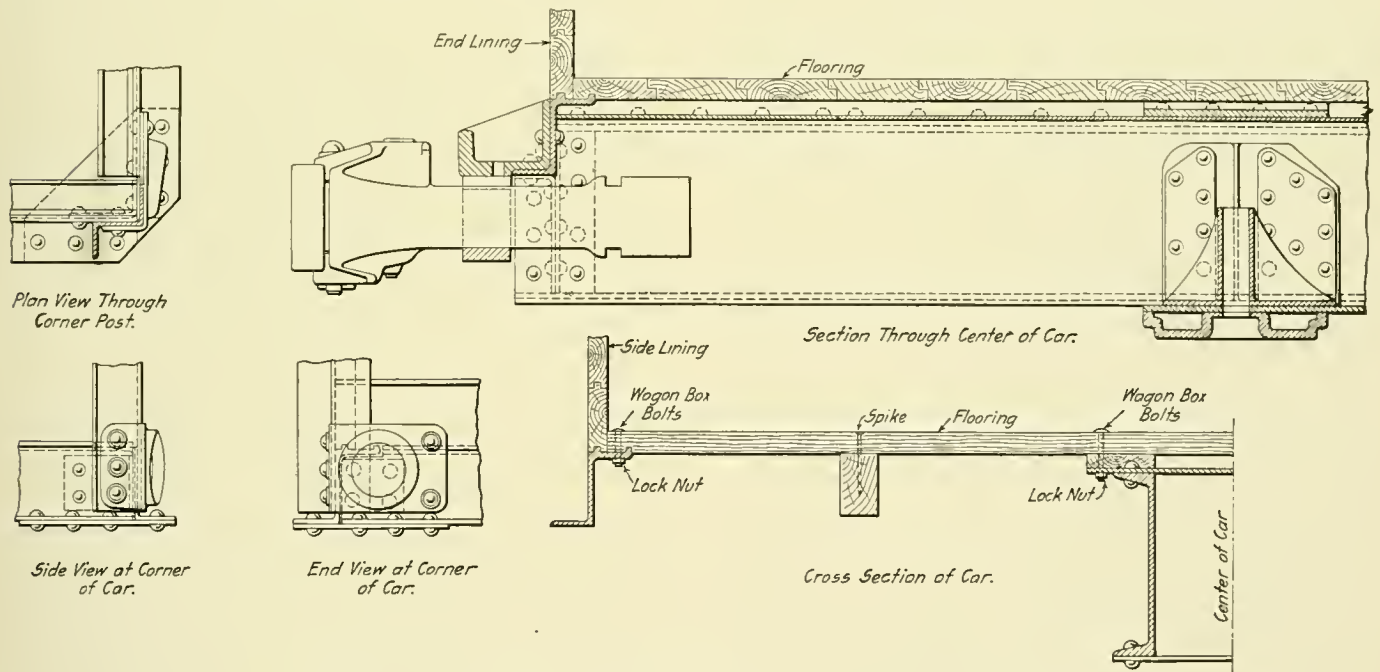

End Construction to Prevent Grain Leakage from Single Sheathed Box Cars

erty made, and all phases of the treatment to which a car is subjected in service are carefully considered and arranged for. At this time, especially, the steel frame single sheathed box car is being generally considered as a design which will meet all requirements for the shipment of any commodity which can be loaded into any house car with the exception, perhaps, of a commodity requiring refrigeration.

The American Society of Mechanical Engineers, at the recent meeting in New York City, carefully considered the box car having the steel underframe as well as the steel upperframe structure, and but little was argued against the single sheathed steel upperframe car. The general opinion is that while the general construction is meeting favor, there is much yet in the detail construction which might be improved upon. The general construction of such a car naturally calls for a close study of the details entering into its design in order to get all the parts to work in harmony with each other, for a chain is only as strong

order to make a permanent grain tight joint, can surely be improved upon. When we stop to consider that the monthly claims for the loss of bulk grain due to leakage from the cars amounts to a total of as high as \$10,000 on many of our larger railroads doing the grain hauling of this country, we must become convinced that some improvements should be made in car construction at this point. This loss is common to cars that have been coopered before loading. It is necessary, therefore, to add to the above the cost of coopering, which amounts to at least \$1 for each time the car is loaded, as the material used for coopering is scrapped when the car is unloaded.

Several methods have been evolved for making a permanent tight joint at this point but none, however, have fulfilled the requirements. Hot tar pitch has been poured in the joint, but it answers the purpose for only a short time, as it soon breaks away from either the sheathing or the floor boards on account of the weaving of the car. Tin flashings have also been used, but



they are only temporary and will not stand the test of service. Many cars are built today having the floor boards gained into the side sheathing boards which, when new, makes a good joint, but it is a question if they will remain tight for grain, inasmuch as this method allows the side sheathing to bulge outward under the grain loads, thus allowing the joint to open up. In all of these methods, however, it will be necessary to destroy and entirely replace them when but few new floor boards are renewed. The scheme of gaining the lower edge of the side sheathing boards for the end of decking boards necessitates the removing of the lower part of the side sheathing in order to remove the floor boards. The gained sheathing also requires more labor and good workmanship if it is to be properly applied.

The Rock Island has just developed a design wherein an absolute grain tight joint is made between the side sheathing and the sill, as well as between the decking and the sill. It does not in any degree depend on the joint between the floor boards and the sheathing, and it cannot be affected by the racking of the car. The arrangement consists of a special Z-bar or angle for the side and end sills which has two ridges rolled in the upper flange, as shown in the illustration. One of the projections fits into the standard groove in the lower edge of the side and end sheathing, and the second fits in grooves in the ends of the floor boards, which are to be cut at the same time the boards are cut to length or squared at the end. While reference is made to a Z or angle section and the illustration shows a 6 in. Z-bar having the continuous projections on the upper flange, other standard sections can be employed, or any section could be used, with a separate steel member riveted on top of the upper flanges, which has the proper projections for engaging in the grooves in the floor and side sheathing boards.

The projection on the top flange fitting in the groove in the siding will not only give a tight grain joint, but also prevent the lower side sheathing boards from bulging out. To overcome this bulging some roads are employing a clip which is secured to the side sill by means of bolts or rivets. These clips could not, of course, be of any considerable length for they would have a tendency to collect any water running down the side of the car which would not only drain into the car but cause the sheathing to decay at this point. In the present design of steel frame single sheathed car, the side supports for the prevention of bulging of the side sheathing are the greatest distance apart at the bottom where they should be the closest. The use of any extra posts or braces for this purpose would, of course, procure the required result, but would materially increase the weight and cost of the car. By using the standard section of Z-bar with projections as illustrated for both end and side sills, the projections on the upper flange can be run continuously around the car, making practically a sealed tight joint at both the ends, the sides and at the corners which the racking of the car will not influence. No special material is needed to make this joint tight, which eliminates any additional expense for labor or material. The floor boards may be readily removed without interfering with any special arrangement or with the side sheathing.

The illustration shows that an extra good design of end sill may be obtained by the use of a 6 in. Z-section. The shape adapts itself to a good design of coupler horn striking casting, and, moreover, the lower flange of the Z-bar need not be cut away to provide the necessary coupler clearance. For the end sill, however, it is not necessary to use a Z section to obtain this grain tight joint as any sections which are rolled can be used with equally good results. No material weight is added to the car, while at the same time a gain of 5 per cent is made in the strength of both the side and end sills by the use of this grain tight construction. No extra labor is required when this section is used, over any other standard rolled section, and the steel mills will furnish the section with but slight extra cost.

As previously stated, too much attention cannot be paid to the detail construction of the steel frame single sheathed box car on

account of the type coming so quickly into such general use without the slow process of evolution and service tests. While this design has been in use only about three years, the reports show that in the year 1913, 20,460, or 49 per cent. of the box cars built were of the steel upperframe single sheathed type.

## CAST IRON WHEEL RECORDS\*

BY H. H. VAUGHAN

Assistant to Vice-President, Canadian Pacific, Montreal, Que.

Practically all railroads have abandoned any form of cast iron wheel record which follows the history of each individual wheel. The writer believes that, apart from the records maintained for guarantee purposes, the only systems in general use are those in which the average life of wheels removed from service for various causes, is determined in various ways. It is usual to show a figure for the average life of wheels obtained by dividing the number in service by the number removed per year, but this figure is not of much value as it depends more on the rate at which the number of wheels in service increases, than in the actual life of the wheels removed. Thus if a number of wheels in service remained stationary for a period of years, while the number of wheels removed increased 25 per cent it would indicate a decrease in the average life of the wheels of 20 per cent, while if during the same period the wheels in service had increased 50 per cent, the same increase in the number of wheels removed would indicate an increase in the average life of 20 per cent.

Now if the increase in the wheels in service had taken place in two or three years, it would have had comparatively little influence on the wheels removed, and so an increase in the life of the wheel might be shown by these figures, while a reduction had actually occurred. In addition reports of wheels removed on foreign lines are not obtained correctly, especially for wheels removed on handling companies account and, in general it is not uncommon for a life of twelve to eighteen years to be shown for wheels, when as a matter of fact they are lasting about five or six.

The figures showing the life of the actual wheels removed can be obtained with considerable accuracy and with simple reports and records. Each wheel is marked with its number, the date cast, etc., so that no complications are introduced by recording the date put into service and the date removed. While no record is usually kept of any time the wheel may be out of service, or the movements of the car under which it has been placed, these factors are relatively unimportant on a large number of wheels, and the average life of the wheels removed is a figure of sufficient importance on any road to justify the records and statements required. It should properly be kept by weight of wheels, so that any alteration that occurs in the life of wheels under the same weight of equipment may be distinguished from the changes due to the introduction of a greater proportion of heavier equipment or similar causes.

While the average life of wheels removed affords valuable information over a period of years, it does not enable the result of any variation in the quality or service of the wheels to be detected until considerable time has elapsed, and then only in a general way. When the wheel foundry methods of the Canadian Pacific were revised in 1908, it became desirable to introduce some system by which it could be determined whether better service results were being obtained or not, without the complications of the old individual records.

This was accomplished in a satisfactory and simple manner by comparing for each year's make of wheels, of the same weight and manufacture, the number removed for various classes of defects in each year of their life. The system does not require any additional reports over those commonly used. The

\*Read before the Canadian Railway Club, Montreal, Que., January 13, 1914.

only information needed is the make of the wheel, weight, date cast, maker and cause of removal, items that are likely to be reported accurately and which are those required for a record of any kind. As the number of wheels of any group cast in each year is known, the number removed in each year's life for each cause may be expressed as a percentage of the number made and

weight of wheel with its subsequent modification to 645 lb. and 625 lb. up to 1912. one of the advantages of this system being that with the records that had been kept it was possible without too much work to go back as many years as necessary to compare the results with those of previous years.

This statement, while giving all the information that is ob-

Year	Worn Flange			Slid Flat			Broken or Chipped Flange			Broken Wheel			Total Operating Defects			Total Manufacturers Defects			Removed from Tenders			Total Number Removed		
	Number	Percent	Total Percent	Number	Percent	Total Percent	Number	Percent	Total Percent	Number	Percent	Total Percent	Number	Percent	Total Percent	Number	Percent	Total Percent	Number	Percent	Total Percent	Number	Percent	Total Percent
1902	6	0.02	0.02	149	0.49	0.49	8	0.03	0.03				163	0.54	0.54	14	0.04	0.04	118	0.39	0.39	295	0.97	0.97
1903	139	0.46	0.48	503	1.66	2.15	38	0.13	0.16				699	2.31	2.85	332	1.09	1.13	814	2.69	3.08	1845	6.09	7.06
1904	362	1.20	1.68	535	1.77	3.92	41	0.14	0.30				958	3.17	6.02	670	2.21	3.34	264	0.87	3.95	1892	6.25	13.31
1905	915	3.02	4.70	408	1.35	5.27	36	0.12	0.42				1382	4.56	10.58	780	2.58	5.92	82	0.27	4.22	2244	7.41	20.72
1906	1081	3.57	8.27	254	0.84	6.11	21	0.07	0.49				1391	4.59	15.17	816	2.70	8.62	21	0.07	4.29	2228	7.36	28.08
1907	961	3.17	11.44	231	0.76	6.87	46	0.15	0.64				1262	4.16	19.33	676	2.23	10.85	17	0.06	4.35	1955	6.45	34.53
1908	771	2.55	13.99	159	0.52	7.39	21	0.07	0.71				983	3.25	22.58	734	2.42	13.27	12	0.04	4.39	1729	5.71	40.24
1909	641	2.12	16.11	100	0.33	7.72	15	0.05	0.76				785	2.59	25.17	539	1.78	15.05	12	0.04	4.43	1336	4.41	44.65
1910	465	1.53	17.64	88	0.29	8.01	10	0.03	0.79	3	0.01	0.01	579	1.91	27.08	413	1.36	16.41	2	0.01	4.44	994	3.28	47.93
1911	223	0.74	18.38	39	0.13	8.14	7	0.02	0.81	2	0.01	0.02	289	0.95	28.03	294	0.97	17.38	1		4.44	584	1.93	49.86
1912	138	0.45	18.83	30	0.10	8.24			0.81			0.02	175	0.58	28.61	188	0.62	18.00	1		4.44	364	1.20	51.06

Fig. 1—Record of Service Given by Canadian Pacific 600 lb. 33 in. Cast Iron Wheels

this percentage may be compared year by year to determine the comparative service obtained from the different wheels.

As the records are compiled on the Canadian Pacific, no attention is paid to the date the wheel is put into service. For wheels made in any one year, the number removed in that year is taken as being removed in the first year of their life, those removed in the next year, as in the second year of their life and so on. This introduces an inaccuracy in the case of any par-

tained for the wheels it refers to, does not enable any comparison to be made easily, and for that purpose a series of such statements for wheels made in successive years are combined as shown in Fig. 2. This statement shows the number of the wheels of the weight it relates to made in each year, and the percentage removed in each year of their life for all causes, except worn flange, slid flat and removed from tenders. A similar statement is made for the percentage removed each year for

Year Cast	No. of Wheels Cast	% Rem. 1st Year	% Rem. 2nd Year	% Rem. 3rd Year	% Rem. 4th Year	% Rem. 5th Year	% Rem. 6th Year	% Rem. 7th Year	% Rem. 8th Year	% Rem. 9th Year	% Rem. 10th Year	% Rem. 11th Year	% Rem. 12th Year	Lbs.
1912	15384	.06												645
1911	42105	.04	.25											"
1910	35710	.04	.27	.85										"
1909	53390	.03	.38	1.11	2.28									"
1908	36165	.11	.56	1.09	1.98	3.16								600 & 645
1907	66730	.30	1.52	3.69	5.85	8.78	12.03							" "
1906	63819	.13	1.05	2.36	4.37	6.19	8.39	10.76						" "
1905	49239	.13	.83	2.40	4.53	7.10	8.98	11.01	13.50					600
1904	32852	.07	.67	1.60	2.84	4.94	7.18	8.62	9.92	10.99				"
1903	35108	.16	1.38	3.45	5.84	8.16	10.96	13.61	15.29	16.54	17.33			"
1902	30288	.07	1.29	2.64	6.33	9.09	11.47	13.96	15.79	17.19	18.19	18.81		"
1901	27749	.16	1.10	3.45	6.30	9.15	11.92	14.1	16.6	19.0	20.38	21.60	22.78	"

Fig. 2—Statement of Canadian Pacific 600 lb. and 645 lb. Wheels Removed, Except on Account of Worn Flanges, Slid Flat and From Tenders

ticular wheel placed in service towards the end of the year, but the error becomes unimportant after a year or so and the labor of compiling the record is greatly reduced.

The statement obtained by this system is shown in Fig. 1, which gives the results for 600 lb. wheels cast by the Canadian Pacific in 1902, the first year for which this statement was prepared. Similar statements have been made up for the same

worn flange, and slid flat and another shows the percentage of broken wheels and broken and chipped flanges for the same series. It is evident that similar statements may easily be prepared for any cause of removal it is desired to investigate, but these are the ones that have been considered important. The elimination of wheels slid flat, worn flanges and removed from tenders, leaves a balance, that while not corresponding to the



classification of manufacturers and operating defects, is broadly affected by the quality of wheels turned out, so that the statement, Fig. 2, is a record of the foundry output in this respect.

This statement shows several interesting features. There is evidently a decided variation in the percentage of the wheels removed of different years' make, and it is only reasonable to suppose that where a larger percentage is removed in a given time, say six or seven years, the life of the wheel is less. If this be granted, some years' makes are evidently considerably superior to others, for instance those made in 1904 were far better than the average while those made since 1908 have been uniformly good.

If all wheels made were accounted for, there would of course be no assumption involved, but by an inspection of Fig. 1 it will be seen that of the wheels made in 1902, only 51 per cent have been accounted for in 1912. It is improbable that 49 per cent are still in service and the difference is therefore to be accounted for by wheels placed under foreign cars or removed on foreign roads and not reported. This discrepancy might be reduced if the number of wheels of any make placed under foreign cars were deducted from the number made before calculating the percentage, but it would introduce a complication of doubtful advantage. The chief effect of this factor is in comparing wheels received under new cars with those made or purchased for renewals. The former will evidently not be placed under foreign equipment to the same extent, but as this number has been under 10 per cent of the total number placed in service each year its effect can be allowed for.

The reliability of the statement as a whole is confirmed by the fact that since 1908 it shows a decreased percentage of

certain that if the wheels are of good quality and carefully inspected there will be less poor wheels to fail in the first year or so, and this result will persist throughout their life. This result is certainly true in the case of 1904 and 1908 wheels, and if it is confirmed by further experience, this form of statement furnishes a simple method of determining within a comparatively short time the service that may be expected from any group of wheels without the necessity for complicated records.

The others are also interesting statements. Wheels slid flat and with worn flanges are not chargeable against the foundry, but they may be largely affected by the shops. Careless taping and mating, cars down on side bearings and sundry other causes

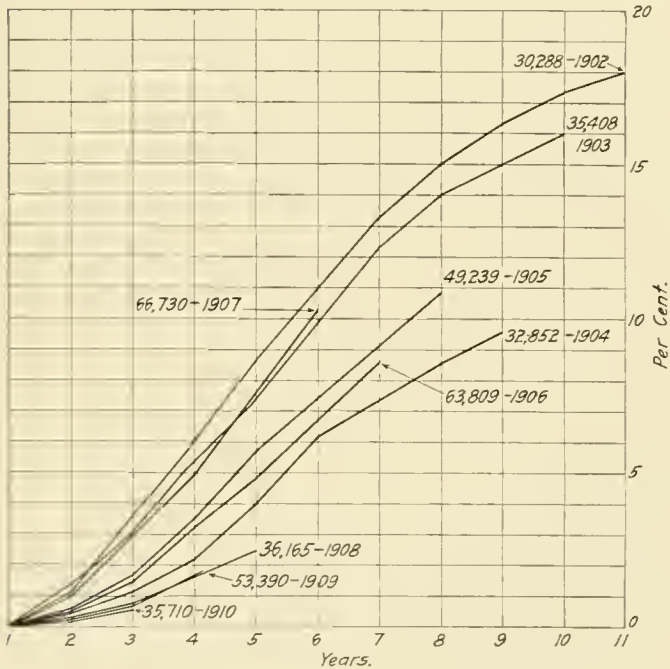

Fig. 3—Failures Caused by Manufacturer's Defects on Wheels for 60,000 lb. Capacity Cars

wheels removed and that the average life of the wheels removed has since that time increased as follows:

Year	Manufacturers' Defects	Operating Defects	Total
1908.....	5 years 2 months	4 years 5 months	4 years 8 months
1909.....	5 years 2 months	4 years 7 months	4 years 9 months
1910.....	5 years 7 months	4 years 9 months	5 years 0 months
1911.....	5 years 4 months	4 years 9 months	4 years 11 months
1912.....	5 years 9 months	5 years 0 months	5 years 4 months
1913.....	5 years 11 months	5 years 5 months	5 years 7 months

An important point in this statement is the general agreement of the results shown throughout the life of any series of wheels with those shown in the first year or two. It appears almost

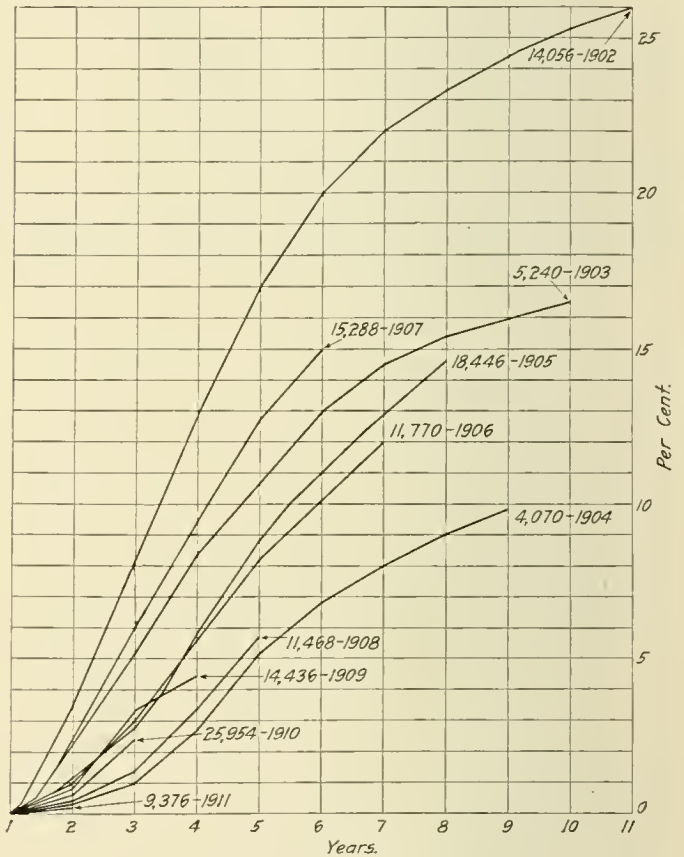

Fig. 4—Failures Caused by Manufacturer's Defects on Wheels for 80,000 lb. Capacity Cars

for worn flanges are all avoidable and results may be followed by means of this report. Slid flat wheels are also caused by improper maintenance and operation, and may be largely reduced by care.

The statement shows that there is comparatively little difference between the wheels removed of the various years' make for being slid flat. There is, however, a most decided difference in the number removed for worn flange, the wheels made in 1906 being considerably better than those of previous years, while there is a still greater reduction in 1908. The percentage of 1908 wheels removed in five years from this cause is only about 40 per cent of the number removed in an equal time of the 1909 wheels and less than 20 per cent of the corresponding number for the wheels made in 1903, 1904 and 1905. In 1908 the method of taping was carefully gone into and the work carried on with greater care so it would appear that the proper carrying out of this work is most important to avoid injury to wheels from worn flanges. To the end of the fourth year the 1909 wheels are even better, so that the 1908 results were not simply accidental, but the consequence of greater care and better methods.

Before leaving this description of these records it is interesting to note that they may be easily plotted. Figs. 3, 4 and 5 show the percentage of wheels of 600 lb., 650 lb. and 700 lb.

weight respectively removed for causes other than worn flange, slid flat, and removed from tenders. These diagrams illustrate the statement that a group of wheels that show up well in the first two years will show correspondingly good results throughout later years. They are also interesting as showing the great difference between various groups of wheels and the improvement that took place in 1908 and subsequent years.

Reference has been made throughout this paper to the revision of the Canadian Pacific foundry methods in 1908 and to the results obtained since that date, which evidently show a considerable improvement. Prior to that date the mixture had been handled by brands and numbers, and as the records show in some years very good wheels were made and in others the results were not so good.

In the years 1906 and 1907, considerable trouble arose, a large number of failures occurring in service caused, as was subsequently discovered, chiefly by iron of widely varying silicon content, but of the same brand, being used indiscriminately. The system of inspection was not sufficiently thorough to reject all wheels of improper quality, and while the records in use at that time did not indicate anything unusual, sufficient trouble

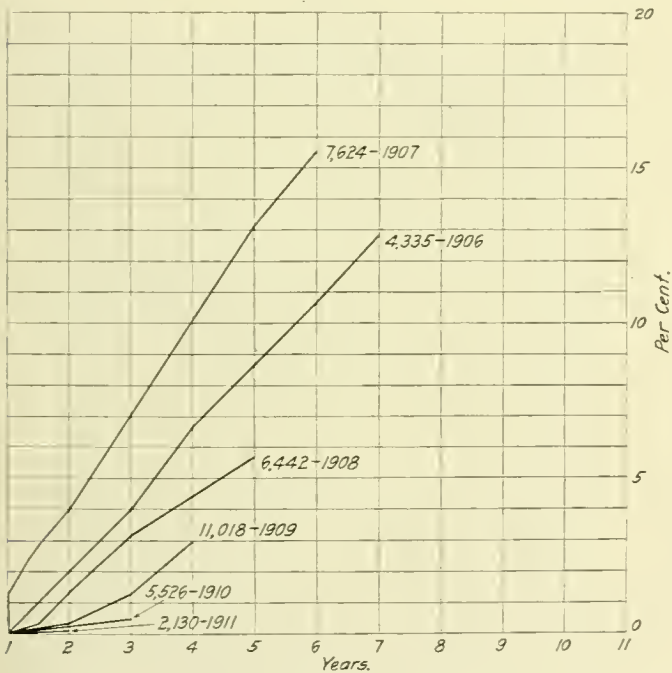

Fig. 5—Failures Caused by Manufacturer's Defects on Wheels for 100,000 lb. Capacity Cars

developed in service to draw attention to the irregularity in the wheels.

Ira B. Lesh was engaged to organize the manufacture on a basis in which the mixtures would be accurately determined by chemical analysis and the inspection effective to reject any of the product that was not of the proper quality. A proper mixture is of course only one of the factors entering into the manufacture of a satisfactory wheel and considerable attention was paid to other points as well, with the results that obvious defects disappeared while the records show that a permanent improvement was obtained.

It is not the intention to make this paper one on the manufacture of chilled cast iron wheels, but in view of the enormous importance of the subject, it is interesting to describe the lines on which the Canadian Pacific practice has been developed and discuss the opportunities for improvement.

The writer considers one of the most important factors in obtaining good wheels is that of inspection. Absolutely uniform and perfect foundry practice is of course the great thing to obtain and the most difficult, but that is a portion of the subject

which would be better described by some competent wheel manufacturer. Inspection should detect those wheels which for any reason depart from the accepted quality, and for this purpose the wheels to be tested should be selected with care and sufficient wheels broken from any days run to insure the rejection of any that are either too hard or too soft.

This may be accomplished by comparing the tapes and chill tests and rejecting all soft and hard wheels until it can be determined within reasonable limits that the wheels accepted are good.

Inspection should, of course, detect all ordinary defects, but it can be carried on to properly protect the heat, and this is most important. One thing should be remembered, that out of the ordinary lot of wheels, 60 per cent will run through their life and be removed without any defect that reduces the life of the wheel so that it looks very much as though the question of getting the other 40 per cent out of the way by better practice or improved inspection were the important ones.

The question of mixtures is a very vexed one. Prior to 1908 charcoal iron was extensively used on Canadian Pacific and the trouble that occurred was caused by its improper use and not on account of its quality. Since that time its use was abandoned for about two years and it has subsequently employed to the extent of 10 or 15 per cent of the mixture. In spite of the great reputation of charcoal iron, it is a question to what extent it can be better than coke iron after being melted in a cupola heated by coke. This statement is not intended to refer to the use of iron with a low sulphur content to prevent the constant increment in sulphur which occurs from remelting with coke, but refers to the value of charcoal iron as against coke irons. Good results have certainly been obtained from the latter if properly handled, but on the other hand if any advantage in strength can be shown for charcoal iron the additional cost is not worth considering. The great question at the present time is that of improving the quality of the chilled wheel. It has only one serious point of weakness, the danger of broken flanges. The records show that the number of broken flanges has been greatly reduced since 1908. If this is correct, the causes are the reinforced flange, careful manufacture, good inspection and a rather hard wheel.

The reinforced flange was introduced in 1906-7 when the 600-lb. wheel was changed to 645 lb., and it would appear that this change made a great improvement.

The Canadian Pacific practice has, during the past few years, run to a hard wheel, the rule being to use the M. C. B. limits for depth of chill, applying them to the pure white iron only. This was introduced on account of an investigation made on a number of wheels causing derailments on account of broken flanges, which showed that the majority were soft wheels, having  $\frac{3}{8}$  in. or less depth of chill. It would certainly appear that a light chill is a cause of weakness not only in the tread under heavy loads, but in the flanges. This may be explained by the structure being that of a hard rigid surface joined to a softer and less rigid back. Grey iron, while often considered as a rigid material, has only about 50 per cent to 60 per cent of the rigidity of the white iron, which probably corresponds closely to that of hardened steel. When this compound structure is subjected to any force, placing a tensile strain on the surface, this strain is largely localized on the layer of white iron, the grey iron beneath it taking less than its share on account of its greater elasticity. It is therefore necessary to maintain a sufficient depth of white iron to resist a force of this nature, which is that brought on the flange by the rail, and it is evident that the white iron is greatly assisted when backed up by a large amount of grey iron, which is the case when the flange is reinforced as in the later designs of wheels. This is probably the correct explanation of the greater amount of flange breakage with soft wheels, and it is apparently confirmed by the results that have been obtained.

There is good ground for expecting that the use of the re-



inforced flange and better knowledge of the causes governing the strength of white iron may lead to considerably better results being obtained from the chilled wheel in the future.

On light equipment with less severe brake service than is usual today, the chilled wheel has given excellent results and is even now most economical and satisfactory in most respects. Flanges practically never break through the line in which they are restricted in strength, and until they do so, there is every reason to hope that the cast wheel may be able to hold its own, and in time to render the good service it has in the past.

## REINFORCING WOODEN BOX CARS ON THE CANADIAN PACIFIC

While a great deal of attention must, of necessity, be given by the railways to providing high capacity in new freight equipment in order to meet severe modern conditions, there are thousands of wooden cars which, with a comparatively small expenditure, can be so strengthened as to make them quite serviceable, even in heavy traffic, for many years to come. A great deal has been accomplished along these lines, some roads

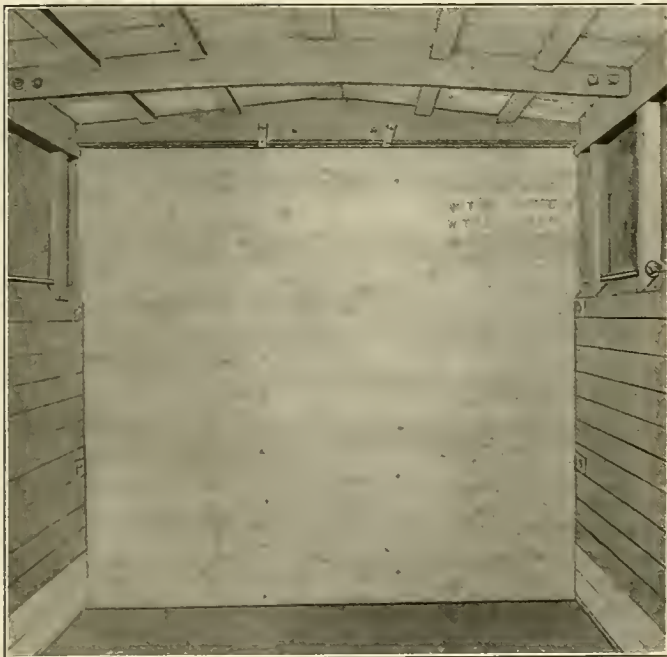

Beside Strengthening the End of the Car the New Lining Forms Grain Tight Joints

even going so far as to apply an entire steel underframe to cars which previously were equipped with a wooden underframe.

In the reinforcing of wooden box cars on the Canadian Pacific to meet the heavier traffic requirements, methods have been adopted which, while providing ample strength, require a minimum of material and expense. In strengthening the ends of the cars, even if the lining is damaged no attention is given to it. The old lining is left in place, and the time which would be used in ripping it out is saved. The end is relined with  $1\frac{1}{2}$  in. or  $1\frac{3}{4}$  in. decking, placed directly over the old lining, the length stenciled on the car being corrected accordingly. This new lining not only greatly reinforces the end of the car, but also is easily made grain tight at all the joints, making it unnecessary to depend on the outside sheathing to hold grain. On the outside of the car, two 3 in. 6.7 lb. Z bars are bolted to the old posts (cracked posts not being removed), and also bolted through the end sill, the end lining and the end plate. The bolts are staggered so that one bolt passes through each board of the new end lining. The new end lining is thus made to assist to a great

extent in supporting the end sill and in turn the ends of the center sills.

In reinforcing the underframe the wooden center sills are removed, but the intermediate and side sills are left in place. The two wooden center sills are replaced by two 6 in. 22.7 lb. Z bars which extend the entire length of the car. The Z bar center sills are attached rigidly to the end sill and also riveted to the body bolster. It has been found that the Z bar center sills, reinforced by their attachment to the bolster and end sill, are sufficiently rigid to transmit all draft and buffing shocks to the bolster, and the latter distributes the shocks evenly over the entire underframe between the bolsters. Whatever flexibility is required is amply provided by the new center sills between the bolsters, and the strengthening of the end is ample to support the end sill and in turn the outer ends of the center sills and their draft gear connections.

Cars which have been strengthened in this way are giving every satisfaction in service. A large number of cars are hav-



The Ends of Wooden Box Cars Are Reinforced with Z-Bar Posts Bolted Through the New Inside Lining

ing these reinforcements added to them at the Angus shops in Montreal, and the new steel sills are also made ready at that point, complete with the draft gear, and are shipped to outlying points for application to cars. To date 8,900 cars have been built new with these steel sills, and 2,600 old cars have been reinforced.

Very few of these steel sills have been sent to the shops for repairs, and the indications are that the amount of repairs necessary would be as great even with the use of the later and more expensive designs of steel underframes.

**GAS IN RAILWAY CARRIAGES.**—We understand that measures are in progress for the introduction of portable gas for the lighting of railway carriages. One carriage has been already furnished with this illuminating principle.—(*Manchester Advertiser.*)—From the *American Railroad Journal*, April 5, 1834.

# SHOP PRACTICE

## TOOL ROOM EQUIPMENT AND MANAGEMENT

BY PAUL R. DUFFEY

The tool room of a locomotive repair shop is one of the most important, but oftentimes one of the poorest equipped and most neglected departments in the whole shop. In many instances it is located in an out of the way corner, causing the workmen who are in need of tools to waste much time in going back and forth.

In properly planning a tool room it is necessary to consider the distribution and care of small tools, the repair of in-

A large metal covered counter, protected by a high wire grating, should extend around the entire service portion of the room, and suitable openings should be provided in the grating to facilitate the distribution of the various tools to the workmen.

In most cases it is well to employ an experienced grinder to look after the grinding of such tools as twist drills, reamers, cutters, etc. Thus it is obviously necessary to have suitable machines installed for carrying on this work. Such an arrangement increases the efficiency of the tool room. The stock of tools kept in the sub-tool rooms should be under the general supervision of the tool room foreman and under the direct supervision of the sub-tool room assistant,

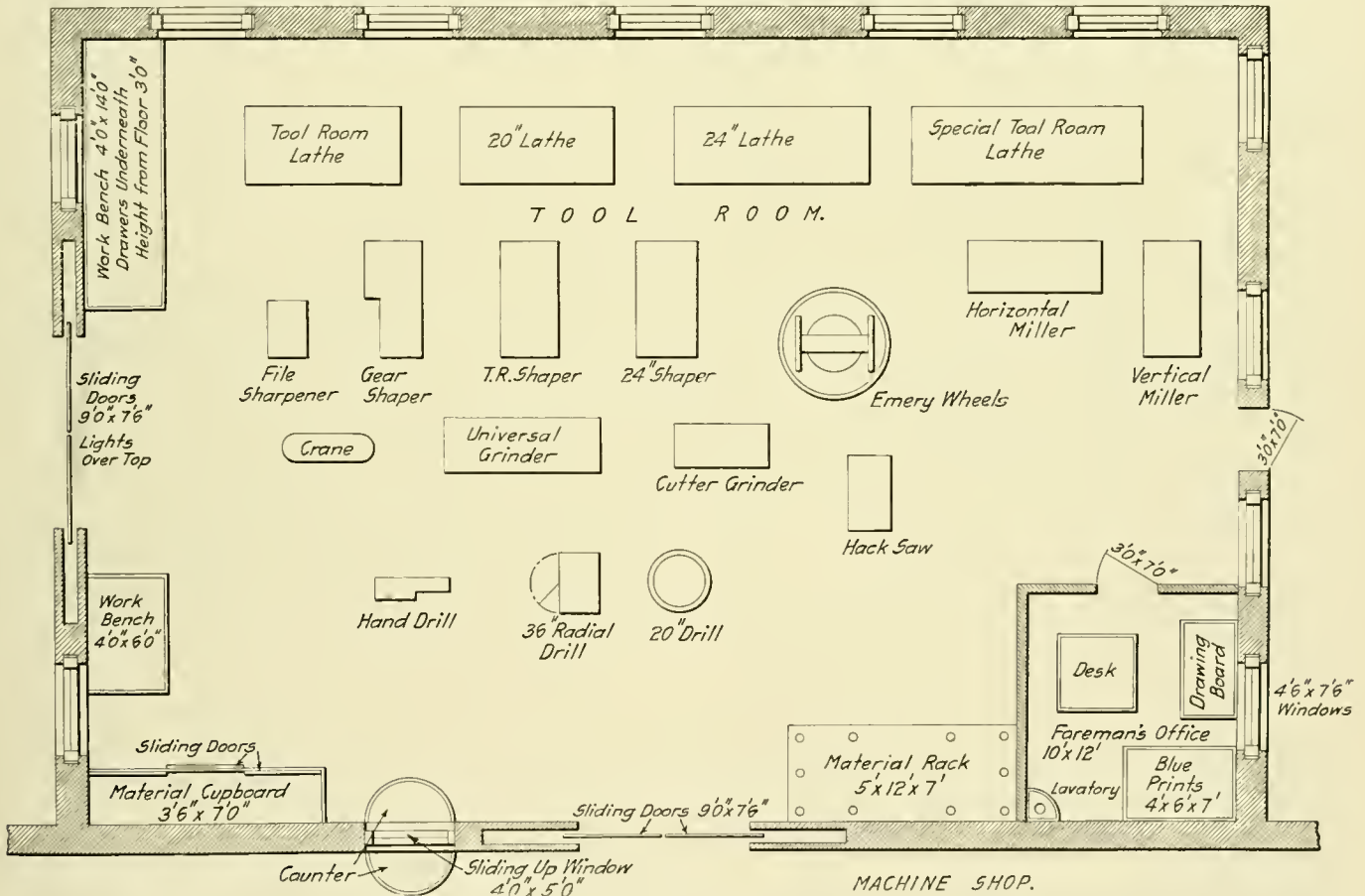

Suggested Arrangement of a Tool Room for a Locomotive Repair Shop

tricate machine parts, special tools, jigs, air motors, pneumatic hammers, manufacture of new dies, etc. Care should be exercised in regard to the location, in order that all the shops may be conveniently served. Large repair shops have as a rule a main tool room and one or more sub-tool rooms, which relieve the main room. The sub-tool rooms may be located, for instance, one centrally in the machine shop, which serves the machine and erecting shop, and if there is a large boiler shop there should be a suitable room provided to serve it individually. The equipment of small and special tools should be governed in each sub-room by the average monthly engine output. The arranging of the room and tool racks should receive particular attention with respect to accessibility. All shelves, pigeon holes and bins should be plainly stenciled, and a sufficient number provided to accommodate all the tools.

who should not only be a good practical man but one who will take a keen interest in his work and strive to work for the company's interest at all times.

Having discussed one function of the tool room we turn to the repairing of machinery parts, manufacturing of new parts, jigs, dies, taps, reamers, etc. This work is as a rule of such quantity and quality as to require a specially equipped shop or room; the ideal place for such a room is away from the noise of the erecting shop. It could be built adjoining the machine shop, and centrally located with reference to other shops. This avoids the necessity of workmen other than those employed in the tool room entering in search of tools and the consequent misplacing of unfinished work. As tool making, die sinking, etc., is work of a high quality, care should be used in constructing a roomy shop, well lighted



and aired, as well as having it suitably equipped with modern machine tools.

The machine arrangement in the tool room of a large repair shop should be studied to meet the most efficient methods of handling the work. As a suggestion of the desired equipment, the following tools may be mentioned. The illustration shows the floor arrangement of the tools:

- 1 12 in. power saw.
- 1 power filing machine.
- 1 tool grinder, 2 wheels, 12 in. and 16 in. diameter.
- 1 universal cutter grinder.
- 1 universal tool room grinder.
- 1 24 in. engine lathe, 7 ft. bed.
- 1 20 in. engine lathe, 10 ft. bed.
- 2 14 in. or 16 in. tool room lathes with all special attachments.
- 1 gear sapper equipped to cut bevel and spiral gears.
- 1 universal horizontal milling machine.
- 1 vertical miller with slotting attachment.
- 1 36 in. radial drill.
- 1 20 in. power drill.
- 1 hand fed sensitive drill.
- 1 24 in. crank shaper.
- 1 16 in. crank shaper.
- 1 pneumatic press.
- 1 portable center grinder (electric drive).
- 1 portable electric crane (self propelled), 3 tons capacity.
- Electric hardening and tempering furnaces.

The tool room should also be provided with a complete set of standard snap, plug and ring gages, micrometers, straight edges and other tools which few individual tool makers carry.

Managing a tool room is a task which requires an efficient foreman. The tool room foreman should be given entire charge of all the sub-tool rooms as well as the main room, and all material requisitions should bear his signature before the material is ordered. In too many instances this matter is slighted and tools of low grade furnished because the persons who ordered the tools were unfamiliar with the requirements. The foreman should be a good practical man, who can read drawings, design and sketch machine parts and has a thorough knowledge of the work for which the tools will be used. In order that he may efficiently operate his department a suitable office, containing desk, blue print and record case, and drawing table, should be provided for his use.

## PROTECTION OF GRINDING WHEELS

The Norton Company of Worcester, Mass., through its research laboratories recently conducted a series of tests on the relative protection offered to the operator of a grinding wheel by an improved type of protection hood and of beveled flanges.

The testing equipment consists of a modern grinding wheel stand, the wheel being driven by a belt from a gasoline engine. For the protection of the investigator, a wooden framework of heavy timbers was built over the side of the stand on which the wheels were to be tested. In all tests the wheels were operated at 6,000 peripheral feet per minute and the speed was very carefully regulated.

In the hood tests the wheels used were 16 in. by 2 in. by 1¾ in., alundum, vitrified and of various grains and grades. These wheels had parallel sides. The hood was of modern type and the wheels were mounted between relieved cast iron flanges 8 in. in diameter. One layer of blotting paper of standard thickness was used between the wheel and each flange. The nut on the spindle was not tightened excessively, but drawn up enough to hold the wheel firmly. The wheels in these tests were broken by dropping a steel wedge between the rest and the side of the wheel in such a manner as to give a severe blow. The object was to duplicate as nearly as possible one of the most frequent causes of accident, namely, that of work being caught between the rest and the wheel.

In the flange test the wheels used were all 24 in. by 2½ in. by 1¾ in. alundum, vitrified, grain 14, grade O, tapered both sides ¾ in. to the foot, with a flat at the center of 4 in. in diameter. One section of standard blotting paper was used between the

wheel and each flange. In these tests five sets of relieved steel flanges tapering ¼ in. per foot were used, the diameters being 12 in., 14 in., 16 in., 18 in., and 20 in., respectively.

The wheels in the flange tests were broken by swinging a 130 lb. cast iron weight against the side of the wheel. This method of breakage corresponds to a common cause of accident when heavy castings, which are suspended by tackle over the wheel, are carelessly allowed to strike the side of the wheel with enough force to cause breakage.

In none of the tests with the hoods did a piece of the wheel leave the hood in a way that could have caused damage. The tests showed conclusively that a well designed protective hood, made of the right material and properly adjusted, affords ample protection for straight side wheels, even when they are mounted between standard, straight relief flanges having a diameter equal to one-half the diameter of the wheels.

It was not the intention of the tests to obtain data from which standard specifications for hoods and flanges could be drawn; nevertheless, the tests, as a whole, brought out a number of points that could be so used. The specifications for hoods for rough grinding should not only require a certain strength, as determined by the design and material used, but they should also require that the top end of the hood have some sliding-tongue device which can be adjusted as the grinding wheel wears, and thus offer at all times the maximum protection possible. They should also contain a definite statement as to the maximum exposed grinding surface allowable for the common variety of grinding. They should further state the minimum size wheel allowed in a hood of given dimensions.

The conclusions on the tests show that protection hoods offer greater safety than do safety flanges. The protection offered by any given taper with a safety flange decreases with the decreased diameter of the wheel. To provide equal safety on all sizes of wheels would require, therefore, a graduated difference in taper. A hood with an adjustable top furnishes equal protection for a wide range in the diameter of wheels.

Second to safety, the cost of operating a given grinding machine is of vital interest. In this respect adjustable hoods have the better of the argument for, as the wheel wears, protection flanges must be changed frequently. Such change involves the removal and remounting of flanges and wheels, whereas, in the case of a hood, the change would merely involve a set screw adjustment.

To provide adequate protection for wheels 3 in. and thicker, the thickness (hence the weight) of flanges would have to be increased beyond that of any flange now on the market. This would mean added momentum to the revolving spindle which, in turn, would require greater rigidity and strength than is found in the majority of present day grinding machines.

Since the face of the tapered wheel becomes wider as the diameter decreases, serious inconvenience is caused in all grinding where the wheel must work in a slot. Tapered wheels do not permit grinding of right angle shoulders as do straight wheels. Laws in almost every country require the removal of dust from grinding. This requires the use of a hood, and if a hood must be used, it might just as well be strong enough to offer protection in case of an accident. A proper hood offers complete protection. Protection flanges do not offer this complete protection, but in instances where a hood would interfere with the proper use of the wheel, flanges offer the next best method.

**BRIQUETTES IN EUROPE.**—While in France, with brittle coal, there are 12,000,000 tons of briquettes made yearly, and in Germany, with soft brown coal, there are 16,000,000 tons made, in Great Britain but 2,000,000 tons are produced, and these mainly in South Wales, where the dry coal briquettes more easily than the greasy English coal which needs a strong binder.—*The Engineer*.

# SPECIAL TOOLS IN THE MACHINE SHOP

Include a Three Tool Boring Head, a Bolt Chuck, and a Jig for Use in Boring of Side Rods

BY WALTER B. LYONS

## THREE-TOOL BORING HEAD

A soft steel three-tool head for the boring bar of a horizontal boring mill is shown in Figs. 1 and 2. The tool slots

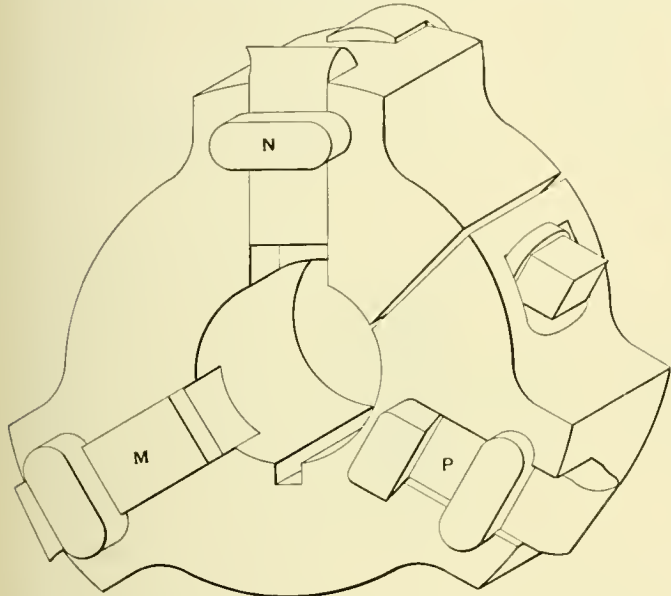

Fig. 1—Three Tool Boring Head

are made  $\frac{1}{8}$  in. different in depth, i. e.,  $\frac{5}{8}$  in.,  $\frac{3}{4}$  in. and  $\frac{7}{8}$  in. deep, which gives each preceding tool  $\frac{1}{8}$  in. lead over the following tool. The middle slot *N* is slotted on both sides of the head, with the slot for the tool clamp extending entirely through

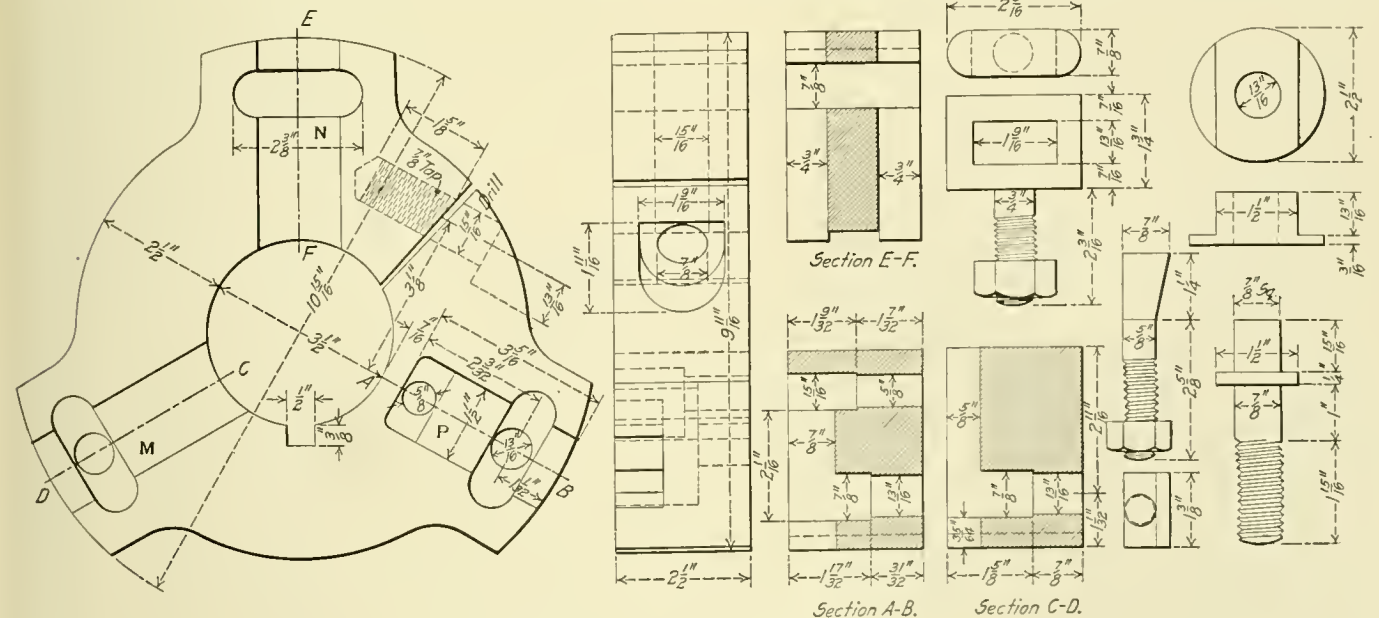

Fig. 2—Sections Through Three Tool Boring Head

the head. This is done so that the tool may be removed and inserted in the opposite side for facing off the back end of the work. The block back of the tool *P* is tapered so that by screw-

ing up the nut on the end the tool may be adjusted to the exact position, and then held rigidly in position by the tool clamp. This wedge also prevents the tool from slipping back if it chances to become a little dull in passing through the bore. It also permits a quick adjustment of the tool, which may be done

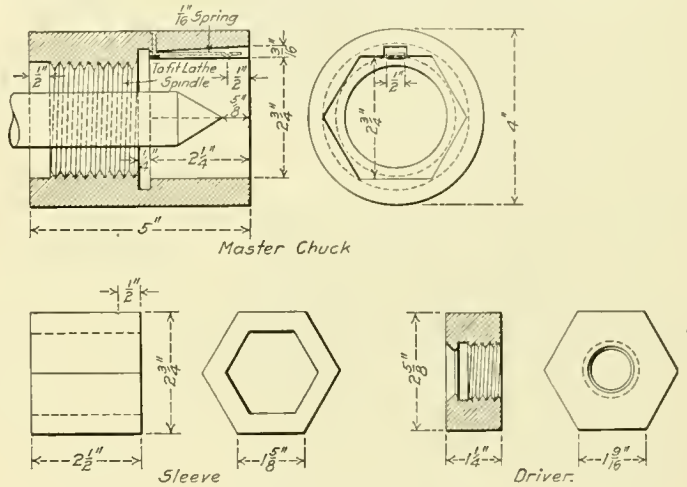

Fig. 3—A Safe Bolt Chuck

as the cut is starting. The body of this head is made in several different sizes, but the tool clamp, wedge and key are all made to fit in any of the heads.

## BOLT CHUCK

The bolt chuck shown in Fig. 3 is constructed largely with an idea of safety; that is, to eliminate as far as possible all

danger of the operator being caught in the machinery. The body of the chuck is made to fit the spindle of the lathe, while the opposite end is made hexagonal in shape and  $\frac{1}{8}$  in. larger





has a working fit in the counter bore in the tool head body, the sleeve being made with a taper on the outside to fit the taper in the body. By screwing up on this ring by means of a spanner wrench, the sleeve is drawn into the head gripping the boring bar as tightly as desired, the split in the sleeve being large enough to pass the key used for driving the head. The

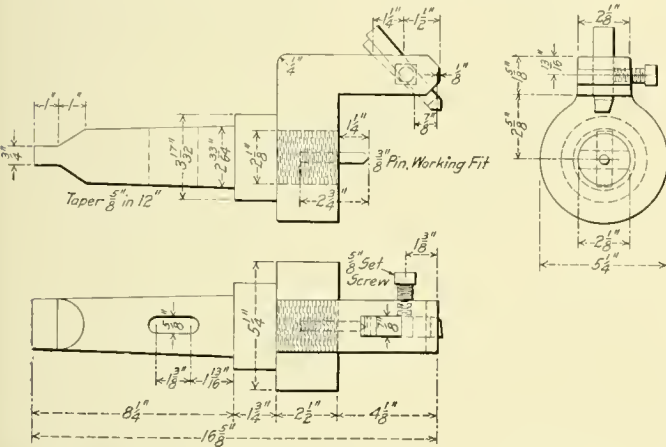

Fig. 6—Boring Mill Tool for Turning Surfaces Which Cannot Be Handled in a Lathe

tool is held in the head by a clamp having two bolts inserted from the back and screwed into the clamp across the front of the head. This clamp is fitted in a recess in order to have as few projections as possible. A bolt with a wedge-shaped head is inserted under the tool and is used to adjust it as well as to prevent it from slipping back, thus making it unnecessary to put

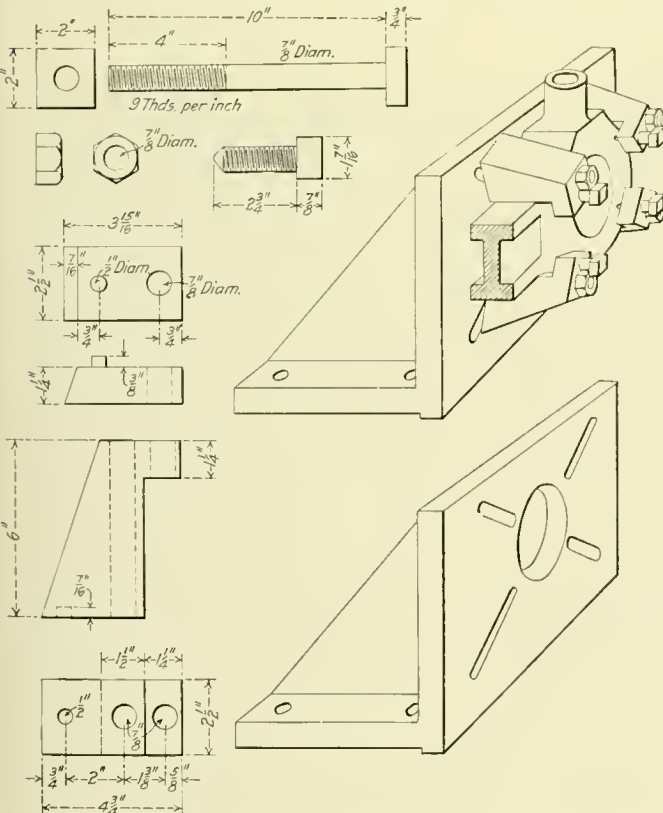

Fig. 7—Clamp for Side Rods

an excessive strain on the two clamp bolts in order to hold the tool.

TOOL FOR TURNING OUTSIDE SURFACES ON A BORING MILL

The tool shown in Fig. 6 was designed for use on horizontal boring mills for turning the grease cups on driving rods, turn-

ing the ends of rocker arms and truing the end bearings of tumbling shafts. It is made in two pieces, as it was found that it could thus be made easier and cheaper. The shank is threaded and screwed into the head and in case the shank should become bent in the neck it is easily replaced, making the tool as good as new. The 3/8-in. pin in the center of the shank is used for centering the work, after which it is removed so as to allow the tool to cut as far as possible. When truing up the ends of tumbling shafts, place the shaft in V-blocks on the table and center it with the 3/8-in. pin in the tool and a dead center placed in the boring bar support. After it is firmly clamped remove the center pin from the jig and proceed to true up the bearings. The tool in this jig is placed at about 15 deg., so that the point will be in advance of the end of the jig.

JIG FOR BORING SIDE RODS

The jig shown in Fig. 7 is used for clamping side rods to a boring machine. It is made from a solid angle plate and has four clamps as shown in the illustration. The bolt hole in the clamp is placed close to the inner edge so as to give the clamp as much heel as possible. The thin blocks shown are used under the clamps when it is necessary to raise them to accommodate the different thicknesses of rods. This method is used so as to bring the lip of the clamp as close as possible to the rod, making it possible to use a short set screw, which will provide a more substantial clamp than where a long set screw is used. With this jig a rod can be quickly removed and another placed in position by simply removing the two top clamps. The angle plate is provided with slots in place of holes to accommodate the different sizes of rods, and by this means the clamps are brought as close as possible to the rods.

LUBRICATING BOTTOM GUIDE BARS

BY ALDEN B. LAWSON

There has always been difficulty experienced in lubricating the lower guide on locomotives when the two bar type is used. The oil is generally fed at the end of the guide, and the crosshead very frequently pushes it off. To overcome this and get the oil to the center of the guide the arrangement shown in the illustration has been placed in service on some Baltimore & Ohio locomotives and is giving excellent service. The oil cup is supported by a wrought iron bracket fastened to the back cylinder

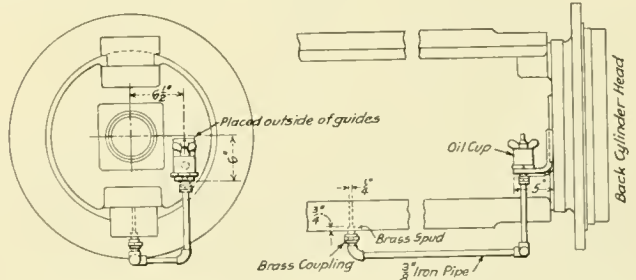

Oil Cup and Connections for Lubricating the Bottom Guide Bar

head and a pipe connects the cup to the under side of the lower guide, the guide bar being drilled. The cup is some distance above the bearing surface of the guide, which permits the oil to feed through the pipe and force itself up to the face. The cup used should be one on which the feed may be regulated.

LARGEST ELECTRIC HOIST IN AMERICA.—One of the largest electric hoists in the world, and exceeded only by a few in South Africa, will be installed in the Granite Mountain shaft of the North Butte Mining Company. The hoist will have a capacity of 300 tons per hour hoisted from a 2,000 ft. level, or 200 tons per hour from a 4,000 ft. level.—Scientific American.



# MACHINING PISTONS ON A VERTICAL TURRET LATHE

BY G. M. NEWMAN

General Foreman, Atlantic Coast Line, South Rocky Mount, N. C.

The accompanying table and illustrations show the method employed in the machining of 22 in. solid pistons on a 36 in. Bullard vertical turret lathe at the Atlantic Coast Line shops, South Rocky Mount, N. C. Sketches showing the special tools used in performing the operations are also included. By referring to the table it will be noted that the operations

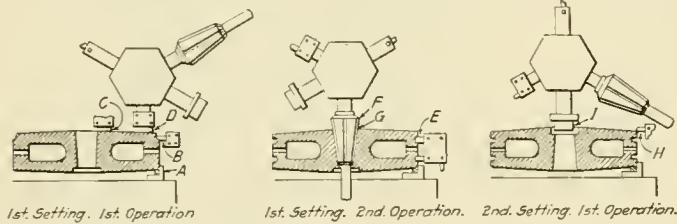

1/4 in. adjustment in size. They are ground with an eccentric relief which prevents chatter and insures well finished work.

The grooving tool holder is made of a good grade of machine steel to fit the side head of the machine; the cutters are

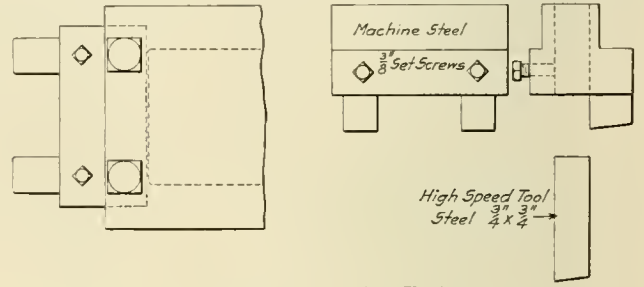

Holder for Grooving Tool

of high speed tool steel, 3/4 in. x 3/4 in. and are so spaced as to cut both grooves at one operation. They can easily be removed for regrinding.

The body of the counterboring tool is made of machine

OPERATIONS AND TIME REQUIRED FOR MACHINING A 22 IN. PISTON ON A 36 IN. BULLARD VERTICAL TURRET LATHE.

Item.	Surface Machined.	Operations.	Depth of cut.	Feed per rev.	Rev. per minute.	Minutes, each operation.	Actual minutes required.
Setting No. 1	1	A Chuck work				5	5
	2	B One tool, 5 1/2 in. length of cut.	Simultaneous cuts	5/16 in.	1/16 in.	6	15
	3	C One tool, 1 1/2 in. length of cut.		1/8 in.	1/12 in.	6	3
	4	D One tool, 1 in. length of cut.		3/8 in.	1/12 in.	6	2
	5	E Gang tool, 3/4 in. x 3/4 in.	Simultaneous cuts	7/8 in.	1/90 in.	6	13 3/8
	6	F One reamer, 6 in. length of cut.		1/2 in.	1/12 in.	6	12
	7	G One tool, 1/4 in. fillet.		1/4 in.	1/12 in.	6	1 1/2
	8	.. Turn piston over				2	2
Setting No. 2	9	.. Chuck work				5	5
	10	H One tool, 1 in. length of cut.	Simultaneous cuts	5/16 in.	1/16 in.	6	2 3/8
	11	I Counter bore, 1/2 in. x 1 in. x 5 in.		3/8 in.	1/16 in.	6	1
	12	.. Remove piston				2	2
Total						63 1/4	44 3/4

Piston in the rough, 23 in. x 6 1/2 in.; weight, 480 lbs.  
 Piston finished, 22 3/8 in. x 6 3/8 in.; weight, 400 lbs.  
 Metal removed, 80 lbs., cast iron.

are grouped so that the shorter ones can be performed while the longer ones are in process. By this arrangement the time necessary to perform eight separate machine operations is reduced to that necessary to perform the three longest opera-

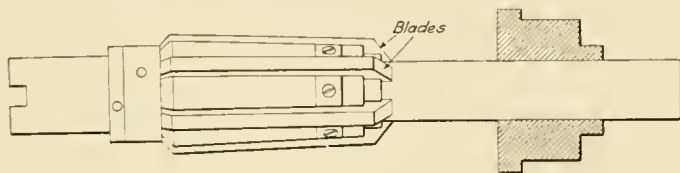

Reaming Cutter Ready for Use

tions. In addition to the time saved by arranging and grouping the operations, the special tools have been so constructed that they are capable of performing a combination of operations as one; for instance, the reamer makes the piston rod fit from the rough, removing the necessary stock and at the

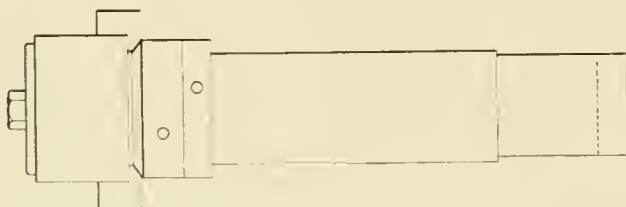

Counterbore Used for All Sizes of Pistons by Changing the Cutter and Bushing

same time reaming the taper and finishing the hole. The body of the reamer is made of a good grade of machine steel while the blades are high speed steel, inserted, and are arranged for

steel. Different size cutters can be applied to the holder by removing the cap screw, plate and bushing; the latter should be the size of the hole to be counterbored.

[Similar practice in the machining of pistons on the Central of Georgia was described in the *American Engineer*, October, 1912, page 526. By combining operations Mr. Newman has apparently been able to considerably reduce the total time required.—Editor.]

## DIAL RIMS FOR ADJUSTING GAGE HANDS

By F. W. BENTLEY, Jr.

Machinist, Butler Shops, Chicago & North Western, Milwaukee, Wis.

Too much attention cannot be given to the adjustment of the travel of the hand on air brake and other gages. As the adjustment is largely an experiment in moving the sprocket slide to which the pull rod of the tube is attached, it is necessary to remove the hand and dial a number of times before the correct travel is obtained. Another method, that of marking the thin edge of the casing before removing the dial, is not commendable, as it mars the gage and the tip of the hand is also too far away from the edge of the gage to permit a close adjustment.

The accompanying drawing shows a method which gives good results. The dials of gages scrapped because of burst tubes, etc., are preserved and cut out in the manner illustrated so as to leave only the rim on which the figures are stamped. When the hand is placed on the spindle it can travel directly over the indications. As most railways use only a few of the best standard makes of steam and air gages, it is not a difficult matter to pro-

cure enough discarded dials to prepare in this way and which will exactly mate with the dial of any gage needing adjustment. The greatest part of the dial being cut away, it is an easy matter to adjust the sprocket slide without removing the hand or the dial while doing so. The use of the false rim renders the

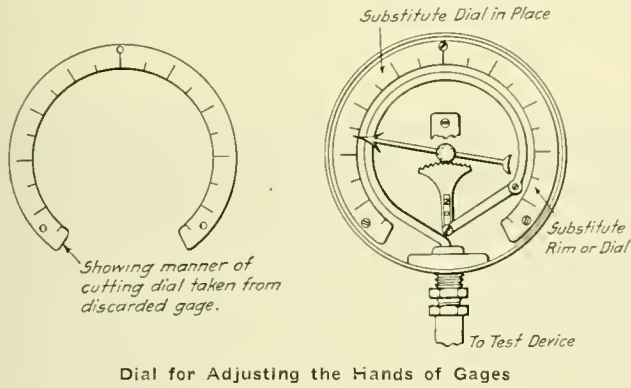

whole interior of the gage perfectly accessible. Five or six of these rims made from the dials of scrapped gages will generally be sufficient to match the dial of any gage needing adjustment, and they have been found to be a great help in securing correct and rapid work.

### SAVING TIME IN THE PAINT SHOP

BY CHAS. E. COPP

Foreman Painter, B. & M. Shops, Concord, N. H.

#### PAINT SHOP STAGING

Good staging is a necessary adjunct to a well-equipped paint shop for handling passenger equipment. Wooden horses and planks have served this purpose in former days, but the modern



Fig. 1—Adjustable Staging for Painting Cars

shop is incomplete without some sort of a permanent staging to be hoisted by the men to the various heights required for performing their work. These stagings are usually constructed

of iron and steel, with the exception of the plank that extends between the supports. Some are made partially automatic by counter-weights which run up on angle iron posts, and are arranged so that the men, with a touch of the foot, may release a dog or pawl that catches in notches in the edge of the angle iron provided for the purpose, allowing the staging to descend slowly to the floor or to the desired height for further work. A stage of this kind is in use at the New York, New Haven & Hartford paint shop at Readville, Mass., and also in the Boston & Maine shop at East Fitchburg, Mass.

Probably the most unique device is that in use in the Boston & Maine shops at Concord, N. H., a photograph of which is shown in Fig. 1. It was installed when the shops were first built about 15 years ago, and continues in use with good satisfaction to the present day. Oak cleats are screwed to the 5½ in. x 5½ in. shop posts and extend nearly to the height of the bracket containing the pulley over which the hoisting rope runs. These cleats are rabbeted on one side to form a runway for the post of the staging-bracket, which has a piece of iron at the top and bottom that runs in the rabbet. At the top of the bracket post and at right angles to it an arm is framed in and strongly braced, as shown. The top of the bracket-post is capped securely with an iron clasp and clamp combined, having an eye to which

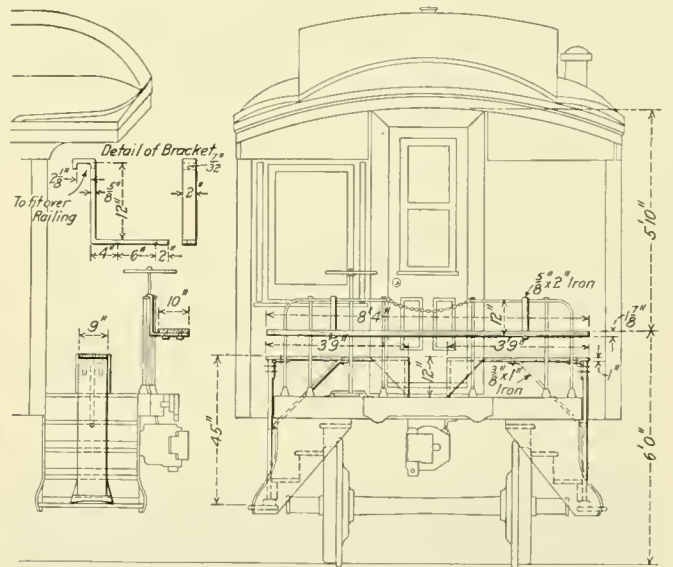

Fig. 2—Auxiliary Staging for Painting Ends of Passenger Coaches

the staging rope is fastened. This rope is passed over the sheave at the top and the other end provided with a link. A series of hooks at suitable heights are screwed to the shop-posts to receive the link on the end of the rope and hold the staging at the desired height. Greasing the grooves with lard oil or tallow and graphite facilitates the hoisting of the stage, which can readily be done by one man. When the stage is drawn to the extreme height it is mounted by a ladder. The planks overlap each other and are securely fastened to their position by small chains that pass through the bracket underneath, so that they cannot be drawn apart. They could be butted together by using a strong sheet-iron flanged bed-piece that should be screwed to the top of the bracket-arm. This staging can be constructed at small cost, as it is mostly made of wood, and it is to be commended especially for smaller shops where the expensive modern stage cannot be afforded. When this stage is hoisted to the top, or high enough to clear the head in walking, the floor is completely clear and trucks with car-cushions, sashes, etc., can be carted anywhere desired.

#### REMOVING PAINT FROM LOCOMOTIVE TANKS

Various means and methods have been in use for years for removing old paint from locomotive tanks, such as the lime and



potash method; blowing in live steam to heat them hot enough to blister it and scrape it off while hot (a terrible ordeal as long as it lasts); using paint or varnish removers; scraping them dry and cold; and lastly the sand-blast method. But perhaps the most novel and unique of all is the scheme recently tried out at the Boston & Maine shops at Concord, N. H. A 2-in. chisel, ground to an angle of about 45 deg., with a round shank of suitable size, is inserted in the tool holder of a pneumatic riveter, and the operator planes off the old paint rapidly.

#### AUXILIARY STAGING FOR THE PAINT SHOP

As desirable and beneficial as permanent staging is in the car repair and paint shops it falls short of making a complete outfit as it only meets the requirements for work on the sides of the cars. Something else must be brought into use on the ends. The use of horses and planks creates too much portable equipment about the shop, and for that reason the arrangement shown in Fig. 2 was devised and has been in active service for a number of years. The advantages of these platforms are their portability and the small amount of space they occupy. The platform stage is 3 ft. 9 in. long and 9 in. wide. The long leg is hinged to the horizontal portion and is held in place by a brace. The brace is held in place by a pin that may readily be removed when it is desired to close up the staging and stow it away. The staging used for working on the hood is simply a 10 in. plank fastened to and supported by two brackets made of 2 in. x 5/8 in. iron that hook over the platform railing. Split keys are inserted through holes in the brackets just under the rail to prevent the staging tipping up when a workman gets too far over on the end.

### JIG FOR MACHINING ECCENTRICS

BY C. W. WARNER

Assistant General Foreman, Erie Railroad, Dunmore, Pa.

A great many sliding plate jigs give trouble because of the way in which the work has to be clamped on. In the jig shown in the illustration six pointed set screws are used to hold the work in position and by the slacking of three of the set screws

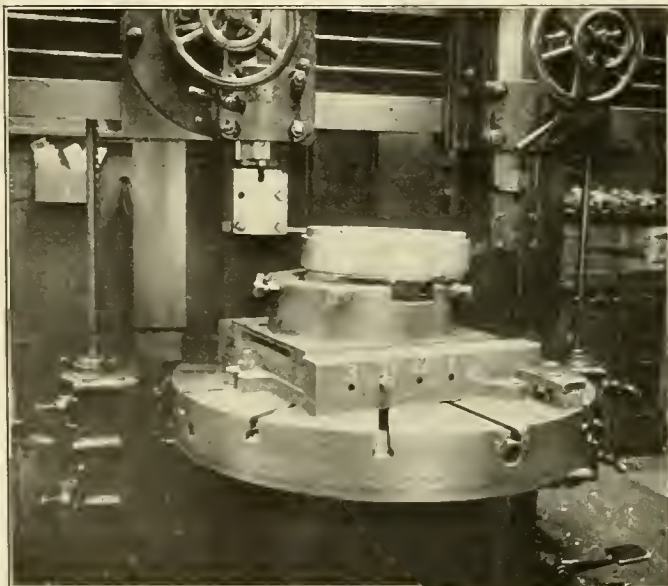

Jig Used for Machining Eccentrics

one eccentric may be removed and another placed in exactly the same position. This enables the changing of the work to be done very rapidly and also saves time in adjusting the position of the eccentric on the machine.

### PORTABLE TIRE HEATER

BY H. E. BLACKBURN

Apprentice Instructor, Erie Railroad, Dunmore, Pa.

The portable tire heater shown in the illustration is made from pipe and pipe fittings with a cylinder head cover for a base. It weighs 110 lb. and can be easily carried about by means of the handles made of pipe. The six burners are controlled

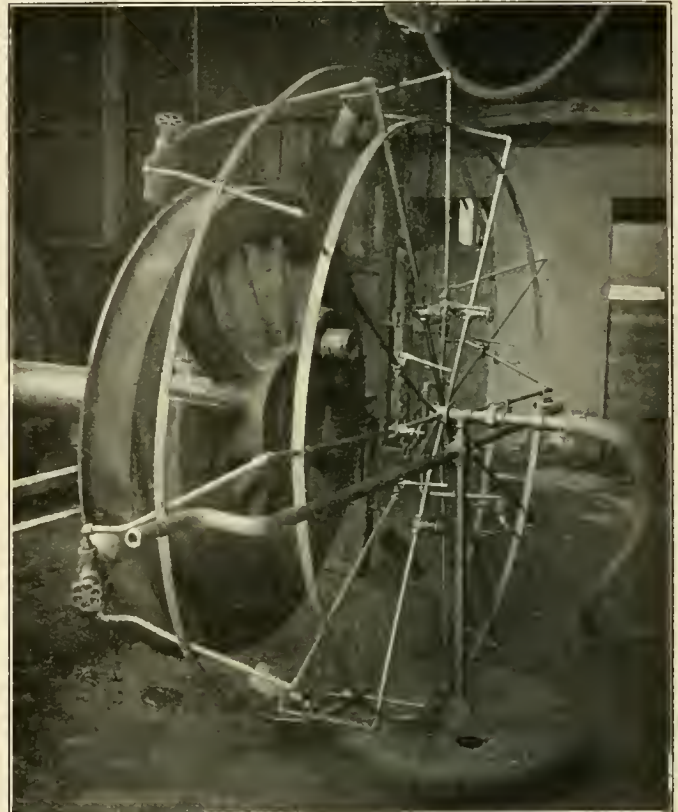

Portable Tire Heater Made From Pipe and Pipe Fittings

by one air valve and each burner has a needle valve for oil control. This heater will remove an old tire in three minutes and heat a new one for application in five minutes, using about three gallons of fuel oil.

**LOCOMOTIVES AS AN EMERGENCY BOILER PLANT.**—When a manufacturing plant is confronted with the problem of replacing an old, inadequate battery of boilers with a new one of greater capacity, it is not a simple matter to make the change without interrupting operation. This condition was ingeniously met, when it recently became necessary for a Philadelphia plant to increase its source of power supply. An estimate showed electric power to be of prohibitive cost and the idea of utilizing locomotives for the purpose was suggested. The location of the plant made feasible the storage of locomotives on a long freight siding and two 4-4-0 type locomotives were obtained from the Pennsylvania Railroad, at a reasonable rental. While these were doing service, the old battery of two boilers was replaced with a new water tube boiler of large size. The process of locomotive boiler substitution was simple. The two old locomotives were hauled to a convenient point on the siding, after their tenders had been uncoupled; their throttle valves were closed, and a connection piped from the auxiliary domes to the main steam line in the plant. They were placed back to back, with an elevated platform between them, allowing sufficient space for two firemen and a coal supply.

# POWDERED FUEL FOR RAILWAY SHOPS

Strong Draft Unnecessary; The Economy of Powdered Fuel, Fuel Oil and Producer Gas Compared

BY J. G. COUTANT

The value of powdered coal as a fuel in the iron and steel industry, as well as for steam boiler plants has long been known, but in spite of its many advantages and the apparent success of the systems of burning it, little progress has been made toward its general adoption. Quoting from Bulletin 16 of the Bureau of Mines:

"The use of powdered coal has passed beyond the experimental stage in Portland cement manufacture and in firing boilers in Europe and the United States. Manufacturers of improved forms of powder burners claim for a given type of coal, an increase of from 15 to 20 per cent in efficiency over common grate firing, and these claims seem to be warranted."

Some of the advantages obtained in burning powdered coal are:

(1) Complete combustion, doing away with losses due to the

It is very desirable to purchase screenings or slacked coal on account of the advantage in price and to eliminate as much crushing as possible, although as a rule the percentage of ash increases as the size of coal decreases. If it is found that the coal contains too much ash or sulphur a great deal of this may be removed by washing. The calorific value of the coal is practically unaffected, the water taken up by the coal being removed by thorough drainage and by the coal dryer.

Coal containing as much over 30 per cent volatile matter as is possible is desirable; gas coal and lignites are to be preferred. The following analysis is of a West Virginia coal, which has given excellent results:

B. t. u. per lb.....	14,000	Ash .....	6.75 per cent.
Fixed carbon .....	58.00 per cent.	Moisture .....	1.25 per cent.
Volatile matter .....	34.00 per cent.		

*Combustion.*—To obtain great efficiency in powdered coal firing, as in gas or oil firing, the combustion should take place in a chamber in contact with highly heated material, fire bricks being the best. A comparatively cool surface will cause a chilling of the fuel and air immediately in contact with it below the ignition point, resulting in incomplete combustion. The combustion takes place practically in two stages. The coal as it emerges from the burner is coked, the volatile matter being liber

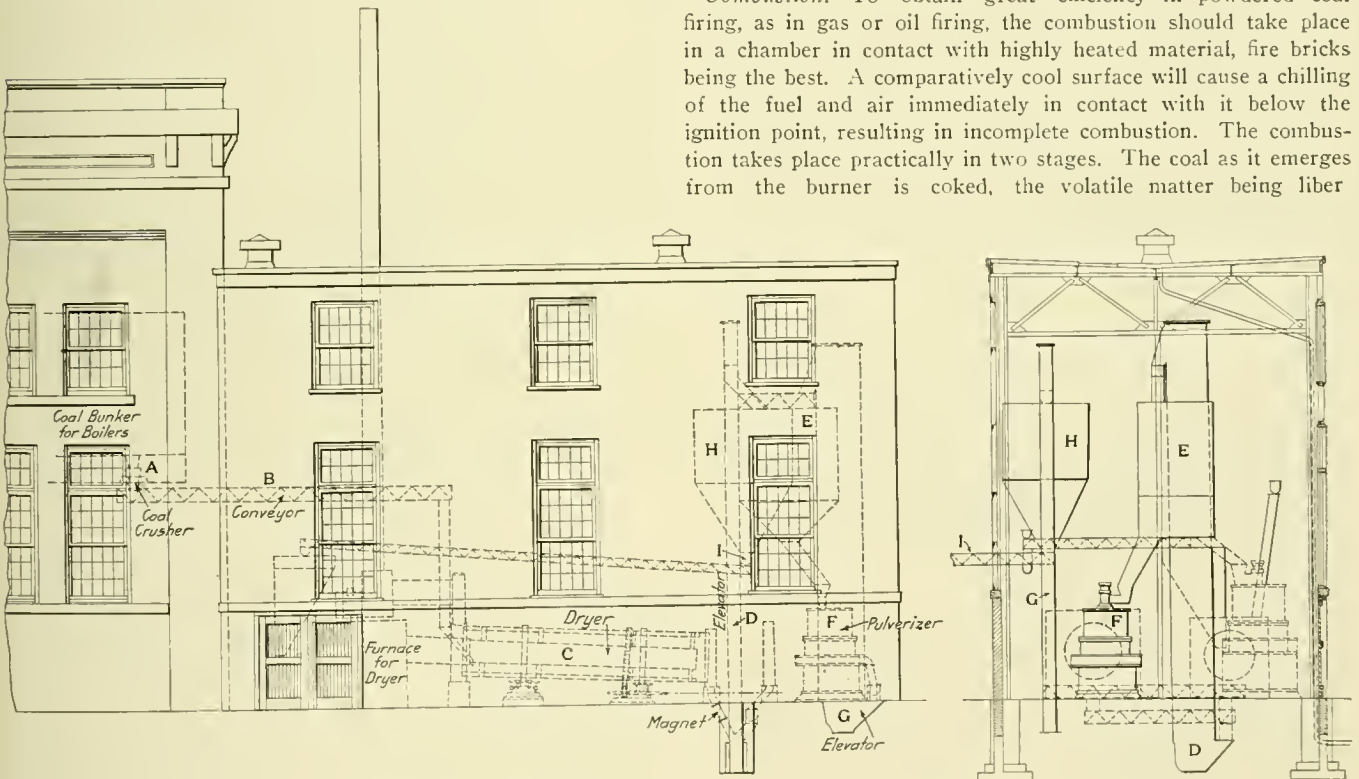

Pulverized Coal Plant of the Lima Locomotive Corporation

carbon contained in the ash and in the escaping volatile matter.

- (2) Total absence of smoke.
- (3) A cheaper grade of coal may be used.
- (4) The plant may be rapidly forced above its rated capacity and sudden demands for power readily met.
- (5) The labor of firing is practically eliminated.
- (6) There is practically no ash to be handled.
- (7) It is well adapted to the obtaining of high temperatures.

*Coal.*—Elaborate analyses and specifications as to the size and grade of bituminous coal and lignite to be used are unnecessary. Every essential requirement of the purchaser may be fulfilled by conforming specifications to the following characteristics: The coal used should contain not less than 30 per cent volatile matter, not more than 12 per cent ash, and not more than 1.25 per cent sulphur

ated and burned at once, while the solid coke is brought to a bright red before it ignites. During these successive operations the coal travels a large portion of the length of the furnace and the carbon is burned.

*Draft.*—A study of a number of tests of heating furnaces and boilers burning powdered coal shows that the necessary draft is very low and ranges from 0.01 to 0.4 in. of water and averages not far from 0.2 in. The low draft is recommended for this work because:

- (1) A strong blast will carry the powdered fuel beyond the zone of combustion.
- (2) The coal and air in a strong blast cause a sand blast action which cuts the brick work and increases the maintenance charges.
- (3) A strong blast cools the lining by concentrating the fuel



and under these conditions it is impossible to maintain combustion.

**Storing Powdered Fuel.**—Cities have, up to recently, limited the storage of powdered fuel to such a small quantity as to prohibit the use of fuel feeders and hoppers, and it has been necessary to experiment with an apparatus for pulverizing and feeding direct to the furnaces. Coal dust mixed with air is often claimed to be of an explosive nature, but this is refuted by many engineers on the basis of experiments which show that explosions can only occur at temperatures high enough to drive off the volatile gases. Whether this is correct or not, the main points to bear in mind are: Avoid the accumulation of powdered coal on rafters and floors where it may be blown about by a draft; provide sufficient ventilation; and avoid a confined place in which the coal dust may become well mixed with air.

**Comparison of Powdered Coal, Fuel Oil and Producer Gas.**—Powdered fuel offers considerable economy over oil or gas firing. The heat obtained is also more intense than that which can be obtained from solid coal, oil or producer gas, if care is taken to preheat the air required for combustion. One barrel of oil contains 42 gal. and weighs from 310 lb. to 332 lb., according to the specific gravity. One cubic foot of pulverized coal weighs, loose 38 lb., packed 46 lb.

Assuming that 1 gal. of fuel oil contains 140,000 B. t. u. and 1 lb. of pulverized coal contains 14,000 B. t. u., the heat value of 1 gal. of oil equals that of 10 lb. of pulverized coal. These are

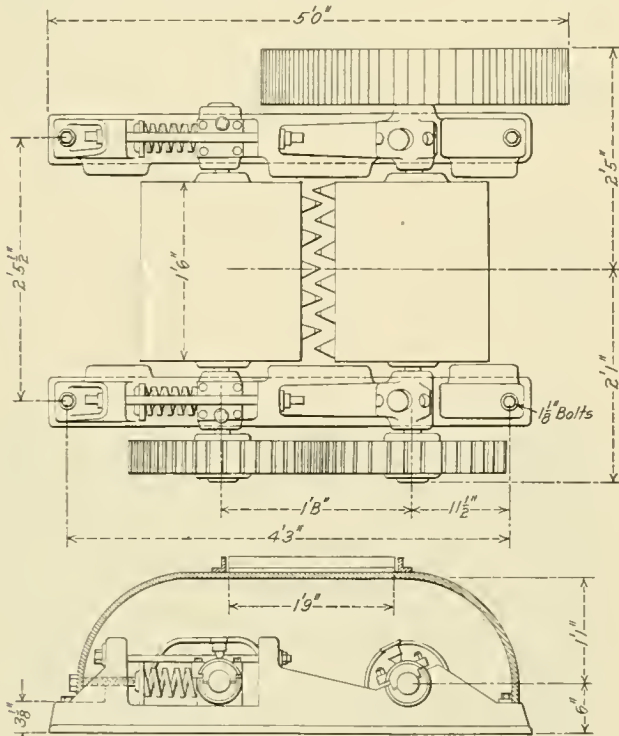

Spring Relief Coal Crusher Made by the Link Belt Company

good figures to remember for comparison. The following table gives comparative figures for oil and different grades of coal:

B. t. u. per lb. of pulverized coal.	Lb. of pulverized coal to 1 bbl. of oil.	Bbbls. of oil to one short ton of pulverized coal.
10,000	588	3.40
11,000	534	3.74
12,000	480	4.08
13,000	452	4.42
14,000	420	4.76
15,000	392	5.10

In estimating the economy of pulverized coal, 35 to 50 cents a ton should be added to cover the cost of milling, as well as the fixed charges on the plant. There will be no other extra charge as the coal is as easy to handle as oil or gas.

Powdered coal has the further advantage over gas of doing away with the gas producer's inherent losses. These are con-

siderable, for it is seldom that the thermal loss in the gasification of fuel by premature combustion, due to heat radiation and convection, is under 20 per cent of the available B. t. u.; to this should be added the loss due to carbon contained in the ash. A total loss of 30 per cent is a conservative figure for good practice.

**Preparation of Powdered Fuel.**—The work necessary in preparing powdered fuel has been one of the greatest obstacles to overcome. For proper combustion the coal must be practically free from moisture. It is first crushed to as small a size as possible and then must be pulverized so that 95 per cent will pass through a 100 mesh screen; after it is pulverized it must be kept dry.

These four operations are usually carried out in a separate

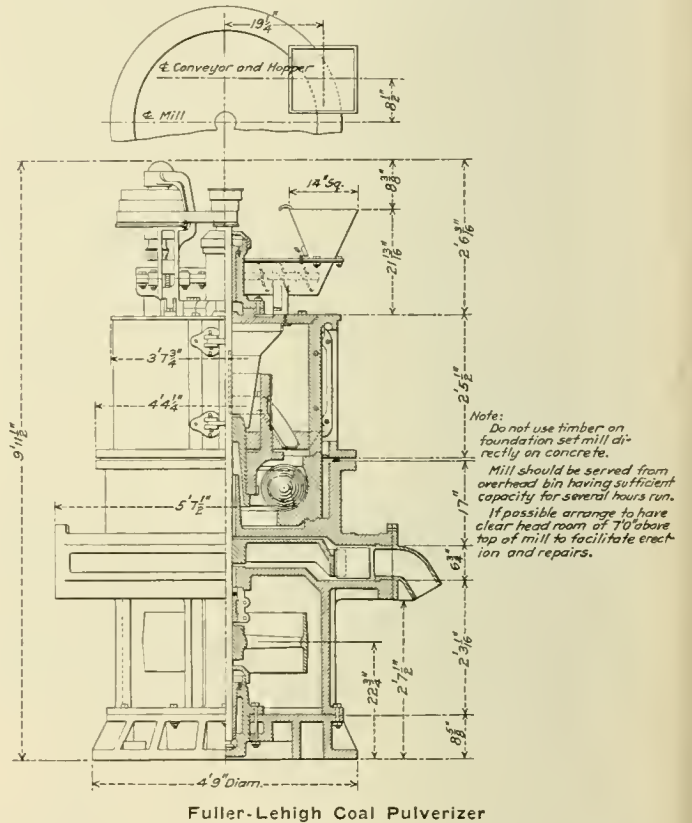

Fuller-Lehigh Coal Pulverizer

building called a milling plant. In order to outline the necessary equipment, the writer has been permitted to describe the powdered fuel plant of the Lima Locomotive Corporation, Lima, Ohio.

This corporation having found it necessary to use some other fuel than oil in the various furnaces, has installed a complete system for burning powdered coal and has erected a milling plant having a capacity of 3 tons an hour, adjoining the boiler room of the power house. This building is practically fireproof, is well ventilated and lighted, and is 55 ft. 10 1/2 in. long, 26 ft. 8 1/2 in. wide, 35 ft. high and is built with a light structural steel frame with a brick wall 8 ft. 6 in. high and corrugated iron above. The roof is of tile. Directly under the coal bunker in the boiler room a small coal crusher *A* has been placed. This crusher has a capacity of 5 tons an hour, but will run to deliver about 3 tons to the conveyor *B*. The object of this crusher is to crush the coal to 3/4 in. size, in order that it will require less time to dry and also to increase the capacity of the pulverizing mill.

The conveyor *B* carries the coal to the dryer *C*, which has a capacity of 3 tons of coal an hour, the maximum moisture content of the coal being 15 per cent. The dryer reduces this to less than 1 per cent. The dryer furnace is designed and equipped for burning powdered or slack coal. The products of combustion pass through a brick lined flue to an inner shell at

a temperature of about 1,200 deg. F., through this shell to the rear end where they turn and pass back through the drying coal and through an exhaust fan to the stack at a temperature of 200 deg. F. The material is fed through the front head into the space between the two shells, picked up by the lifting buckets and dropped on the inner shell by the revolution of the machine until it reaches the rear end where it is raised by the elevator *D*. Great care should be given to the drying of the coal. When dry it requires less power to pulverize it and when pulverized will flow almost like a liquid so that there will be little danger of the dust clogging up pipes or hanging in hoppers. Further, as previously mentioned, the combustion of powdered coal takes place in a highly heated chamber where the volatile matter and moisture are distilled before the ignition of the fixed carbon; therefore if the coal contains moisture it will delay ignition and high temperatures in the furnace can not be obtained. The amount of moisture in the powdered coal should not exceed one per cent.

It is advisable to place an electric magnet on the chute leading from the dryer *C* to the elevator *D* to remove all iron from the coal, as it would be likely to damage the pulverizing mill.

The elevator *D* raises the dried coal to the bin *E*, which is of eight tons capacity. It is well to apply a vent to this bin to allow some of the remaining moisture in the coal to condense in the outside air. From the bin the coal flows by gravity to a feeder mounted on the pulverizer. This feeder is driven directly from the mill shaft by means of a belt. The grinding

tion, coal should be pulverized as fine as possible. If 95 per cent will pass through a 100 mesh screen the quality is considered good.

The elevator *G* raises the pulverized coal to the overhead bin *H*, which is of eight tons capacity and which discharges to the conveyor *I*. This conveyor extends out of the building for loading the cars which distribute the coal to various points about the plant.

## DEVICES FOR SHOP USE

BY LEROY SMITH

### GANG PUNCH

The general arrangement and details of a gang punch and die for punching irons for making dead lever guides, or slack adjusters for trucks, is shown in Fig. 1. It will be noticed that only two holes are started at the same time, and as soon as they are fairly started and the starting strain is diminished, two more holes are started. The punch and die are designed to be used on No. 4 Hilles & Jones vertical shears and can be attached very readily.

### DIES FOR FORMING SLACK ADJUSTERS

The shear and bending dies shown in Fig. 2 are used for making slack adjusters. The dies shown in the upper part of the illustration are used on a Hilles & Jones shear. They will

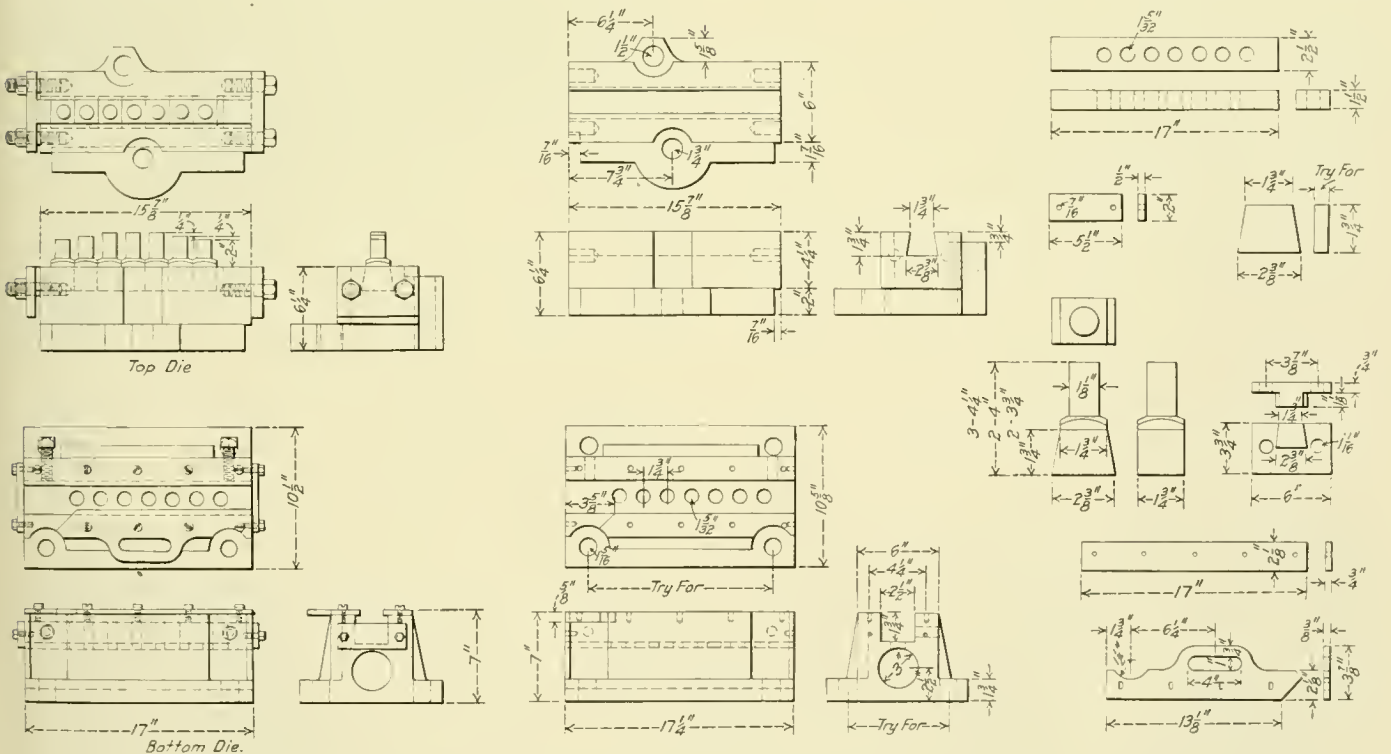

Fig. 1—Gang Punch for Punching Slack Adjuster Rods

is done by four unattached steel balls which roll in a stationary, horizontal, concave grinding ring and the coal discharged by the feeder falls between the balls and is reduced to the finished product in one operation. The mill is fitted with two fans; the upper fan lifts the fine particles from the grinding zone to the chamber above while the lower fan acts as an exhaust and draws the finely divided particles through the finishing screen and discharges them to the elevator *G*. This machine possesses the maximum mechanical efficiency, is economical in cost of installation, operation and maintenance, and grinds coal containing 4 per cent moisture to 200 mesh.

To obtain the highest heat values and instantaneous combus-

tion, coal should be pulverized as fine as possible. If 95 per cent will pass through a 100 mesh screen the quality is considered good. The elevator *G* raises the pulverized coal to the overhead bin *H*, which is of eight tons capacity and which discharges to the conveyor *I*. This conveyor extends out of the building for loading the cars which distribute the coal to various points about the plant.

### LAGGING PULVERIZING MACHINE

The general arrangement and details of a machine for grinding or pulverizing boiler lagging, so that it can be made into



a paste to be applied to portions of the boiler where it is impracticable or impossible to use slabs or forms to fit the curva-

The machine does away with the old hand method of breaking up the material and makes a very suitable material for the paste.

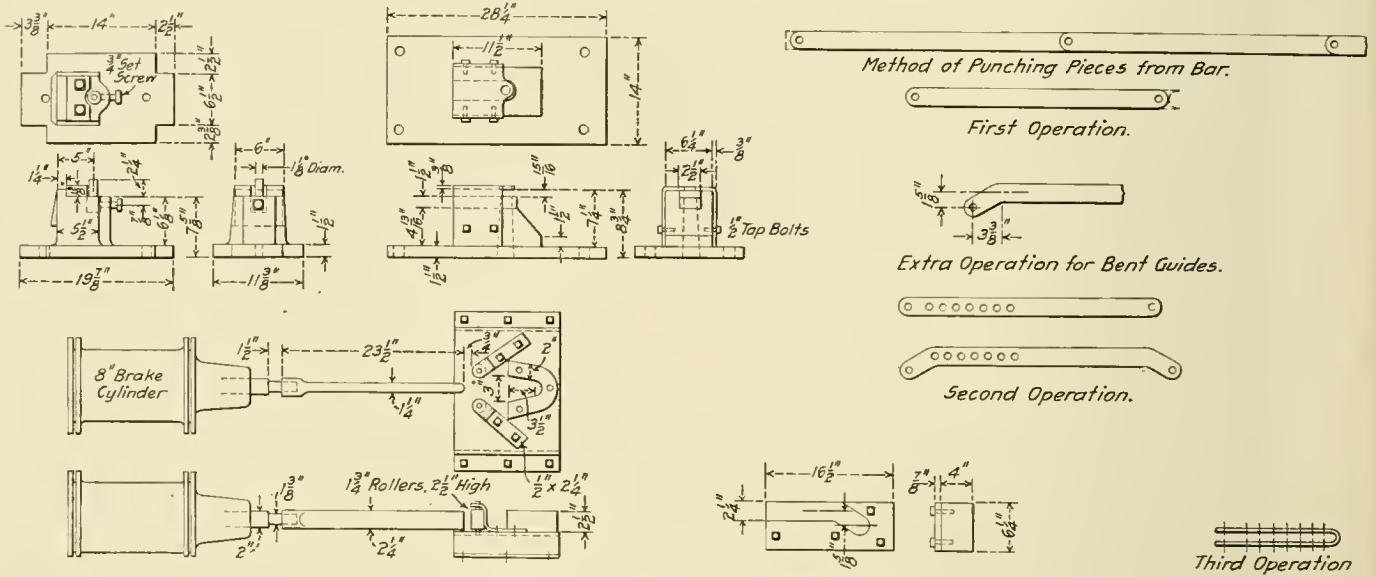

Fig. 2—Apparatus Used in Making Slack Adjusters

ture or fittings of the boiler, is shown in Fig. 3. For this purpose old or broken slabs are used to be broken or pulverized.

With the exception of the four cast bearings, the machine can be built of material found at nearly every shop.

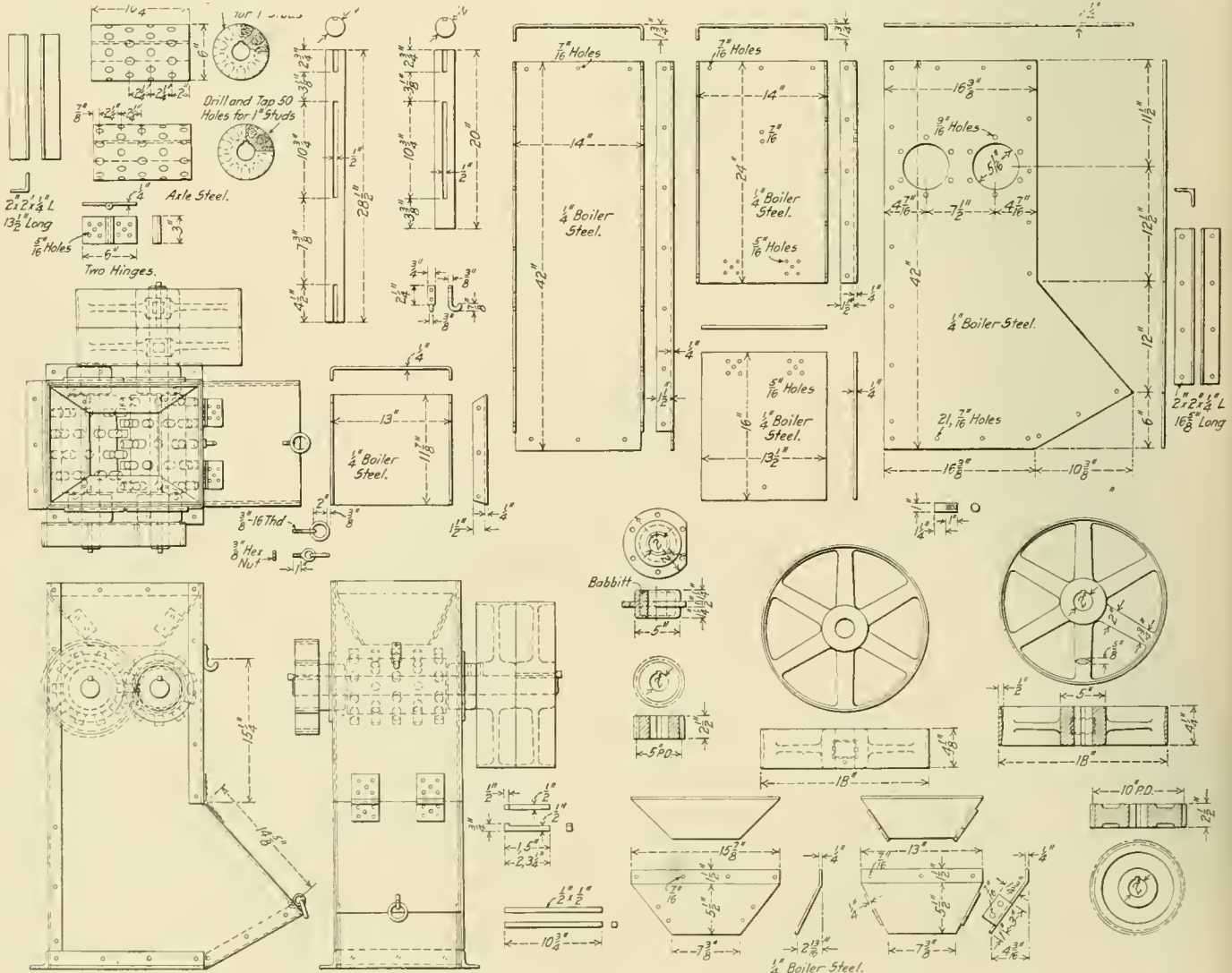
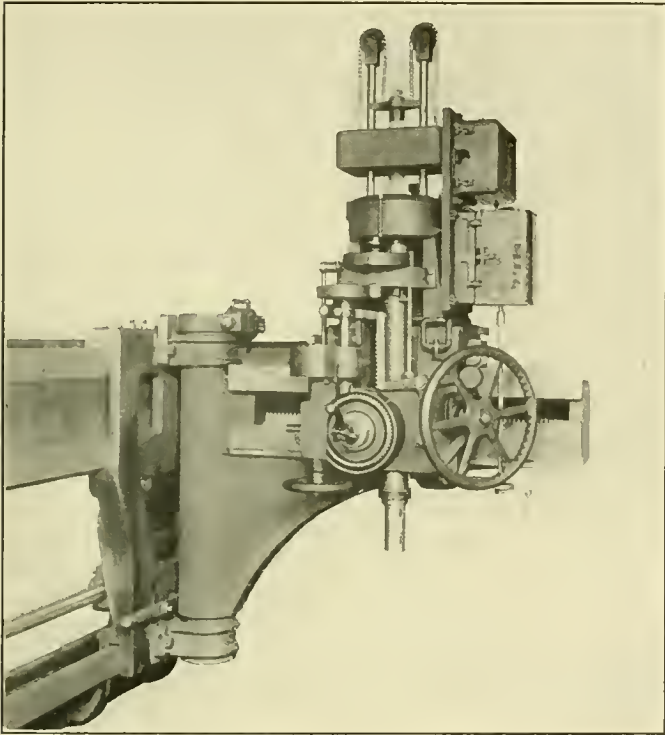

Fig. 3—Pulverizing Machine for Grinding Scrap Boiler Laggings

# NEW DEVICES

## FOUR SPINDLE RADIAL DRILLING MACHINE

The powerful four spindle drilling machine shown in the accompanying illustration has been developed by Edwin Harington, Son & Company, Inc., Philadelphia, Pa., primarily for drill-



One of the Arms of the Four Spindle Radial Drill

ing holes in boiler plates and other similar parts in locomotive shops. Each of the heads has a capacity for drilling a  $1\frac{1}{2}$  in. hole at a cutting speed of 65 ft. per minute in steel plate.

The four radial arms are mounted on one long cross rail and each has a power lateral traverse in addition to the radial and a 30-in. in and out movement of the arm and the spindle heads. Each head carries its own driving motor and all movements of each are controlled by the operator from his position in front of the spindle.

The spindle heads have adjustable steel rollers running on the wide top track of the arm providing easy movement by the hand wheel and worm in an angle rack. The variable speed,  $7\frac{1}{2}$  h. p. motor is mounted on the back of the head behind the arm and the controller handle is brought down behind the traverse wheel. The motors have a speed range from 825 r. p. m., to 1,650 r. p. m. The gearing from the motor has two changes by a positive tooth clutch operated by a lever on the left side of the head. The spindles have a large diameter,  $2\frac{1}{2}$  in. in the sleeve, and a squared upper end for the driving gear. They have a vertical traverse of 15 in., and a movement of 30 in. on the arm. Ball bearings are provided for the drilling thrust and under the counterweight yoke.

The feed has three changes by selective pin and is driven by gears from the spindle through a safety friction. Feeds from .005 to .015 in. per revolution are provided. A positive tooth clutch controlling the feed worm can be operated either by hand or automatic trip. A wheel is provided on the worm for hand feed and the rack pinion is connected to the worm gear by a quickly operated saw tooth clutch and hand lever for the spindle return.

The arms are of heavy box section and are mounted on the saddles by roller and ball-thrust trunnion bearings. The binder on the top trunnion is operated by air through a hose connection to a valve on the spindle head. The saddles have a long bearing on the top rail to prevent tipping, with a support against the lower rail for the thrust. The power traverse gearing is carried on each saddle, thus permitting independent motion in either direction by means of a double clutch between bevel gears. The  $7\frac{1}{2}$  h. p. motor for driving the traverse operating shaft is located at the left end of the base and has sufficient power to move all of the heads at one time.

The cross-rail is made double, the top part carrying the di-

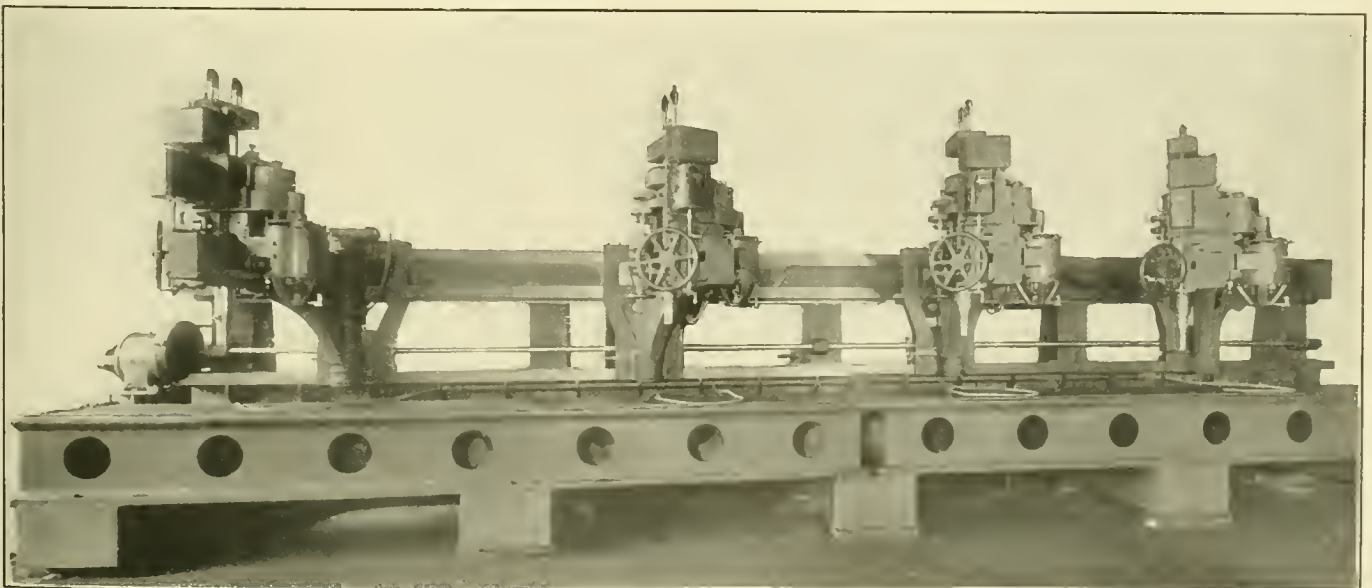

Four Spindle Radial Drill for Boiler Shop Work



rect load and side strain, and the bottom taking the drilling thrusts. These rails are fastened on five heavy box section up-rights which are mounted on a deep, ribbed, cast iron base running parallel with the cross-rail. Five cast iron sub-bases support both the cross-rail and table, and are to be bedded below the floor level.

The table is made in two parts joined in the center to make one continuous surface. It has a working surface of 30 in. by 40 ft. and is 24 in. high. Three T-slots run the full length and a large gutter is provided to drain to a tank in the foundation. The cutting lubricant is distributed by a motor driven pump to a flexible hose at each spindle.

The floor space required is about 9 ft. 9 in. by 43 ft. 4 in., and the overall height is 10 ft. 5½ in. The weight, including the motors, is 85,500 lb.

### CAR WHEEL DROP PIT

An improved type of drop pit for removing and replacing car wheels at large terminals has been in successful use for some time on the Intercolonial Railway of Canada. It is manufactured by the Modern Drop Pit Company, Moncton, N. B.

This pit is operated by a vertical air jack 12 in. in diameter

suitably arranged plate on the bottom of the car. This makes it unnecessary to remove the sections of the running rails before lowering the wheels, as is usually the case with drop pits, since they form part of the car in this design.

The car with the sections of the running rails is held in the normal position in the track by four struts hinged at the bottom and extending diagonally inward as is shown in the illustration. These struts take a seat on an angle and are operated by a lever at one side of the track. At the bottom the struts rest in suitable pockets in the castings, which are supported by the concrete foundation. This makes the removable section of the track as solid as any part and the passage of heavy cars does no damage to the mechanism.

When it is desired to remove a pair of wheels they are located centrally over the removable section. The air is then turned on, the piston reaches the bottom of the car and takes the weight of the wheels and car from the four struts, which can then be swung back into the pockets at the side and the small car with the pair of wheels is lowered until it rests on the transverse track at the bottom of the pit. The piston then continues to sink and clears itself from the car, which is rolled to one side and the wheels are lifted from the pit by a crane or hoist. The car can then be run back over the piston, lifted

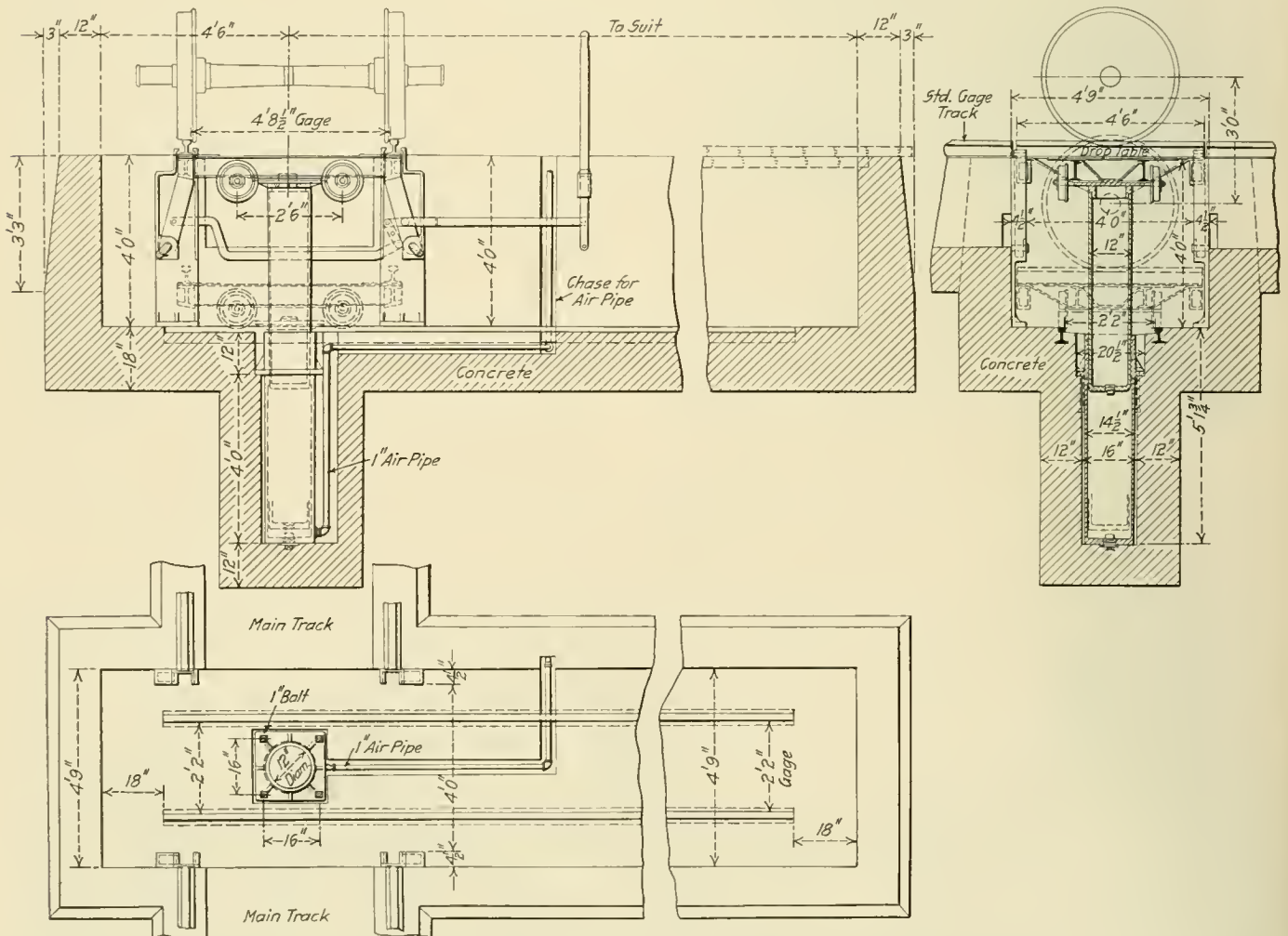

Improved Drop Pit for Removing Passenger Car Wheels

which obtains its supply from the ordinary yard or shop air line. The removable section of the running rails forms part of the steel framework that includes the wheels for moving the load transversely after it has been lowered. The large piston from the cylinder is not fastened to this car but carries at its top a broad base plate with a boss in the center, which rests on a

in place and another pair of wheels removed or a new pair put in place as desired.

**BONUS TO IRISH RAILWAY WORKERS.**—The directors of the Great Northern Railway of Ireland have voted a sum of nearly \$50,000 to be distributed among the staff in the form of bonuses.

### UNION DROP BRAKE SHAFT

All railroads have experienced more or less difficulty in properly maintaining hand brakes on flat cars due to the brake shafts being damaged when the cars are loaded with long material, or on account of their being removed to accommodate the loading, and not replaced. This naturally causes a heavy expense and, under the present safety appliance laws, is very

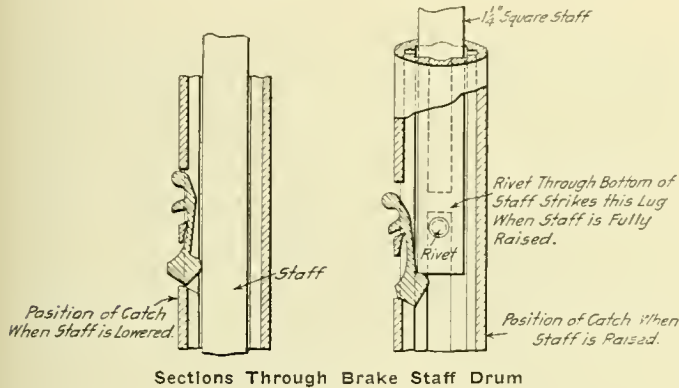

Sections Through Brake Staff Drum

serious, as the hand brakes must be maintained in an operative condition at all times.

The Union Railway Equipment Company, Chicago, seeking to eliminate these difficulties, has recently placed on the market a new type of drop brake shaft for flat and gondola cars. As shown in the illustration, this brake shaft is arranged to drop

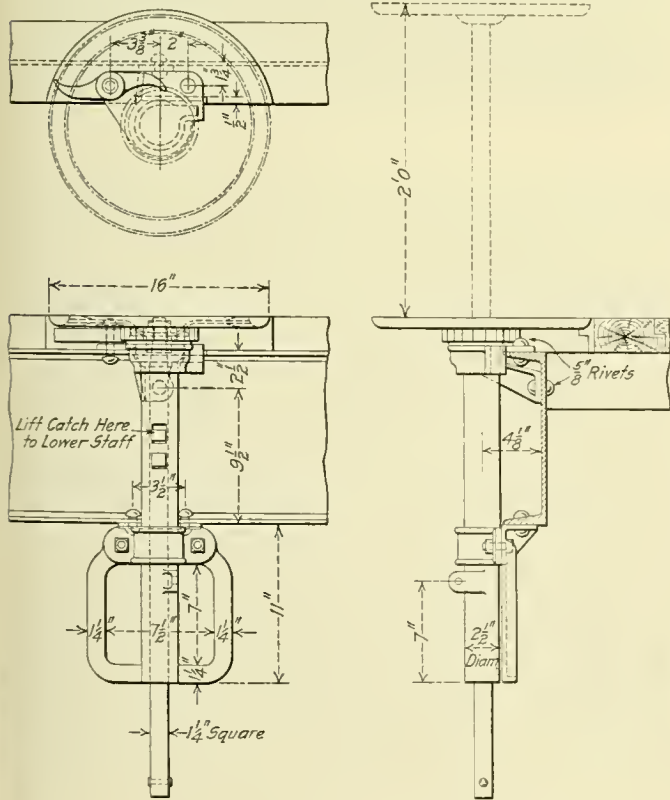

Application of the Union Drop Brake Shaft

vertically by tripping the pawl located in the face of the malleable iron brake shaft drum. In the dropped position the hand brake wheel and the upper end of the shaft are flush with the top of the car floor, which will permit of loading the car with timbers, logs, structural steel or any long material without causing any damage to the brake shaft. The shaft is raised to the

operating position by pulling it up by the hand brake wheel, the pawl in the drum locking it automatically in that position. A rivet, placed in the end of the brake shaft, strikes a lug in the brake shaft drum when the shaft is fully raised, thereby preventing it from being pulled all the way out. The design of the pawl is such that, when the shaft is fully raised, it will drop of its own weight to the locking position, from which it can only be released by raising it by hand from the exposed end.

The brackets, drum or sleeve, hand wheel, ratchet wheel and pawl, and chain guard are made of malleable iron, and the shaft is 1 1/4 in. square steel. The shaft is designed to meet all requirements of the United States safety appliance laws. It can be applied to old cars as well as new, and at no more expense than the old style shaft. The castings are furnished to suit any end sill construction, either wooden or steel.

### ROLLER FRICTION CLUTCH FOR THROTTLE AND REVERSE LEVERS

An objection has often been made to the notched quadrants on throttle and reverse lever riggings, because of the impossibility of obtaining a delicate adjustment of the throttle or of the cut-off, and the insecurity of the fastening after the notches become worn. James F. Howie, 910 Hoge building, Seattle, Wash., has perfected a clutch which aims to overcome these objections.

This type of roller friction clutch employs a flat faced quadrant, which is of the same general shape and has the same po-

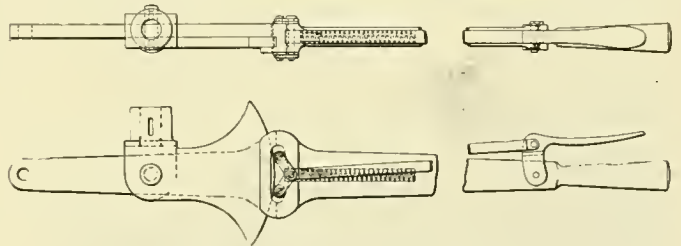

Howie Friction Clutch on a Throttle Lever

sition as the usual notched quadrant, and a handle latch with a coil spring which is also of the arrangement now in common use. The throttle or reverse lever itself, is altered at the point of contact with the quadrant where it has been expanded and an opening cut through on both sides. This opening is flat on the bottom and inclined upward from both ends toward the center at the top. Two rollers are set in this opening and are connected by links at each end to the center pin where the connection to the latch is also made. This opening is in such a

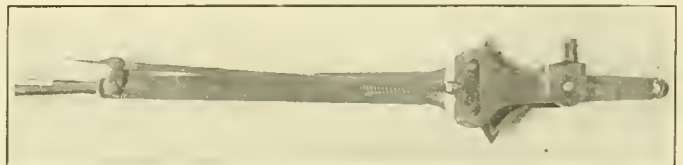

Throttle Lever With a Roller Friction Clutch

position that the center of the quadrant slightly overlaps it and the rollers are of a size which gives them a wedge action between the quadrant and the lever as they approach the end of the opening.

Since there are two of these rollers, both acting in the same way but on opposite sides, it is evident that the wedge action will have no tendency to move the lever from the position it occupies when the latch is released, and furthermore, that



the gripping will be very secure and any tendency to move in either direction will only tend to increase the grip. It will further be seen that a very light spring, which means an easily operated latch, can be used and that the releasing of the rolls will be easily performed, allowing the lever to be conveniently adjusted.

The difference between the throttle and reverse lever construction is simply a matter of size, the principle being the same in both cases. This device is being manufactured by the Hofius Steel & Equipment Company, 908 Hoge building, Seattle, Wash.

## CINCINNATI EIGHTY-FOUR INCH PLANER

In the design of its new 84-in. planer, the Cincinnati Planer Company, Cincinnati, Ohio, has included a number of new and original features which, together with the careful study of the proper placing of the controlling levers, has made this as easy to operate as most of the smaller machines. Rapid power traverse is provided for all the heads in any direction, and all movements are independent of each other and can be operated whether the table is in motion or not.

The motor on the top of the housings serves a four-fold purpose; it is used for driving the rapid power traverse and the feed to the heads; also for elevating and lowering the cross-rail and driving the pump which lubricates the ways. The pinion on the motor shaft engages a large gear on the horizontal rapid traverse shaft from which the pinion that drives the feed clutch receives its power. This is shown at the extreme right. Near the center of the horizontal shaft is a gear meshing with a pinion on the gear case of the elevating device, through which

heads operate both the rapid power traverse and the feed. Turning these handles to the left engages the traverse and to the right, the regular feed, and in no case can both be engaged at the same time. The handle at the lower end of the rail is used for reversing the direction of the rapid traverse. All this is contained in the gear case at the end of the rail, and at no time is it necessary for the operator to step from his regular position for any of these changes.

All the gears are thoroughly guarded against accidents to the operator and all heads are taper gibbed throughout. The clapper boxes are clamped by a heavy clamp and three screws instead of the usual two bolts through a cored slot. The housings are of massive box form, tongued and doweled to the side of the bed and further fastened at the top by an arch of box

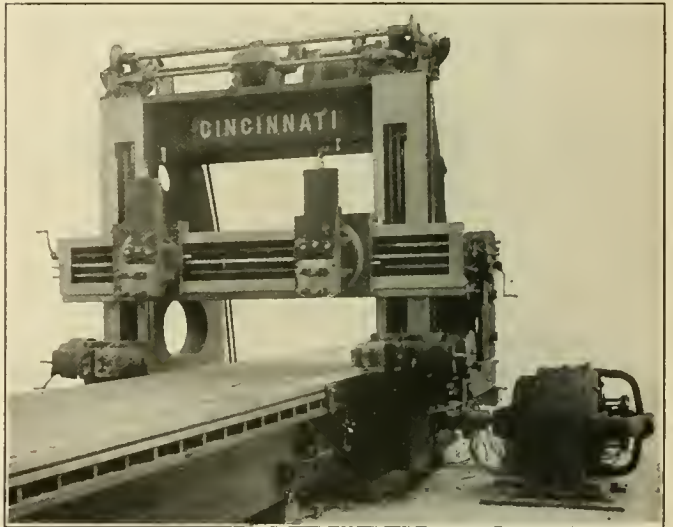

Improved 84-Inch Planer With Reversing Motor Drive



Motor Drive for the Rapid Power Traverse and for Feeding the Heads; Also for Raising the Crossrail

the power is transmitted for raising and lowering the cross rail. A lever from this gear case passes to the left side of the machine and controls the raising and lowering clutches in the gear case.

The feed of the tool heads receives its power from the driving clutch which has a connection to the bevel gear on the large horizontal shaft. The motion passes through the vertical shaft to a set of spur gears and to the trigger gears on the end of the rail and side heads.

The driving clutch is tripped by a rod which receives its motion from the tumbler and dogs on the side of the table and bed. The amount of feed is varied by the graduated slot heads which indicate the exact amount of feed at all times.

Rapid power traverse is obtained from a second vertical shaft on the side of the housing, very similar to the feed arrangement. The small handles shown on the end of the rail and side

form closed on all sides and open only at the ends where it fastens against the housings.

The ways of the bed and table are oiled by forced lubrication from a pump at the back of the housing.

All driving gears are of steel and the pinions and table racks are of steel forgings.

The illustration shows the machine with a reversible motor drive. The motor is connected directly to the driving shaft through a flexible coupling. The controller is mounted on the housings. Ten cutting and ten return speeds are available.

## PNEUMATIC DRILLS EQUIPPED WITH ROLLER BEARINGS

An improved type of "Little David" pneumatic drill has recently been brought out by the Ingersoll-Rand Company, 11 Broadway, New York. This drill has connecting rods running on roller bearings combined with crank shafts running on ball bearings.

The shell is so designed that the entire motor apparatus may be assembled or dismantled through the crank case by the removal of the cover. The motor or engine is of the angular four-cylinder, single-acting, reciprocating piston type, each pair of pistons being attached to opposite throws of a double crank shaft, and acting in balance. All four connecting rods are exactly alike and are interchangeable. Each consists of but a single part made by drop-forging a piece of selected steel. The connecting rods run on Hyatt roller bearings and are attached to the pistons by spring arrangements which facilitate assembling. The piston ends of the rods are ball shaped and the flat steel springs are slipped over them. These balls have their bearings

in the centers of the pistons, forming ball and socket joints, permitting the connecting rods to yield to pressure from any direction without causing the pistons to bind in the cylinder. This construction also permits the pistons to turn in the cylinders so that wear is evenly distributed.

The crank shaft works on ball bearings of the separator type, which, it is claimed, is superior to the full type of bearing for machines of this character operating at medium and high speeds, as in the full type of construction the balls come in contact and

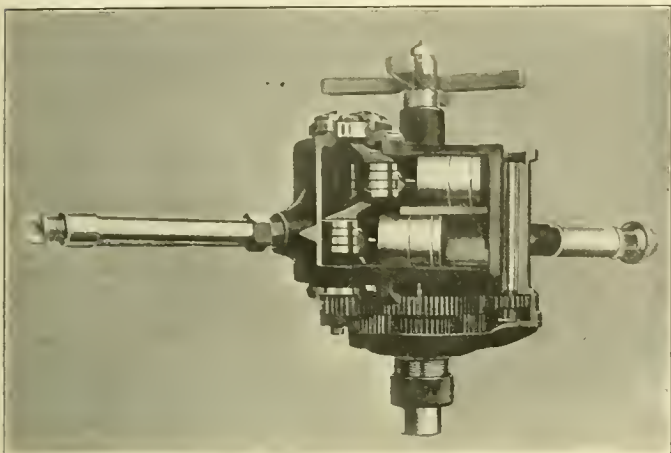

Part Sectional View of the Little David Drill

wear flat rings on their circumferences in a short time, resulting in loose bearings and generally unsatisfactory operation. This rapid wear is largely due to the fact that the balls are rotating in opposite directions at their points of contact.

The spindle is provided with a ball thrust bearing interposed between the shell and feed spindle in such a manner that the main frame is relieved of all strain.

Each valve controls two pistons which act on alternate strokes.

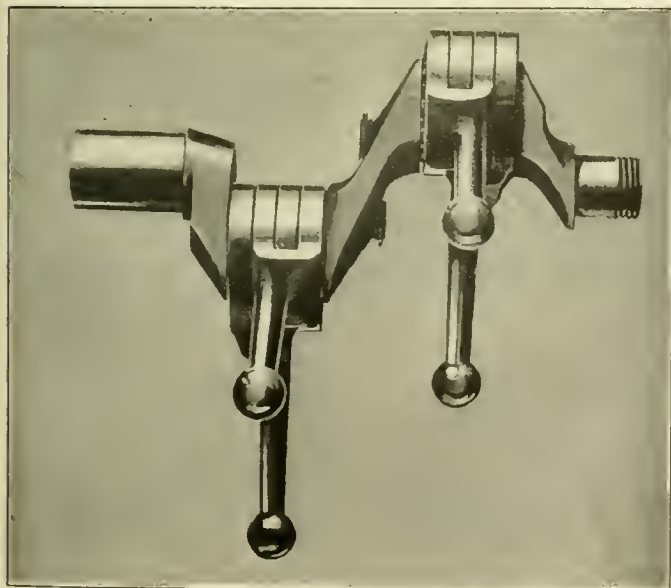

Roller Bearing Crank and Connecting Rods

They are geared to the crank shaft through a spindle gear. The valves are of steel, are hardened and ground and operate in bronze bushed chests.

These tools may be made reversible or non-reversible at the will of the operator. This is accomplished by changing the position of a sliding sleeve on the throttle handle. With the exception of the light wood-boring type, all sizes are provided with compound gearing, insuring great power at all speeds.

### AIR VENTILATED JOURNAL BOX

A car journal box which will permit the passage of a current of air over the journal and around the brass, without allowing the admission of foreign matter, has been patented by W. E. Crist, of Baltimore, Md. The illustration shows a construction for a 5½ in. by 10 in. M. C. B. journal box, and is typical of the arrangement for any size.

It will be seen that the current of air caused by the movement of the train does not enter the journal box, but, by its passage through a duct on the side, it causes an induced current outward from the forward side of the box as is shown by the arrows. For instance, if the car is traveling in the direction shown by the arrow *A* the air enters the mouth of nozzle *B*, passes down through the outer port *C* and discharges at the bottom of port *D*. This causes a partial vacuum in the inner port *E* and through the vent *F* to the inside of the box. As the nozzles are on both sides of the box, the heavier atmospheric

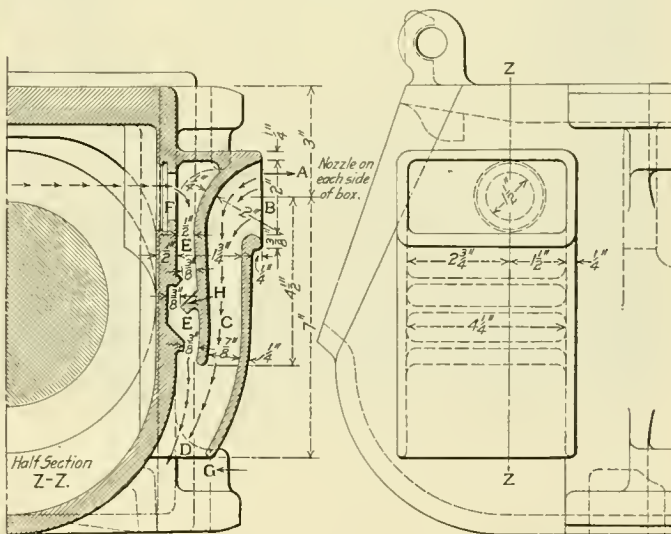

Journal Box Arranged for Induced Ventilation

pressure on the outside will cause a moderate flow of air into the box through a similar port *E* and vent *F* on the other side. The air passing over the bottom of the nozzle at *G* also tends to increase the vacuum. Baffles *H* are inserted in the inner port as an extra precaution to prevent any foreign matter such as cinders, etc., entering the vent.

It is evident that when a train is moving this arrangement will cause a continuous, slow passage of air through the journal box and around the journal and bearing. It is believed that this will have enough cooling action to prevent hot boxes.

### POCKET SLIDE RULE

A circular slide rule of pocket size has been devised by Lucien E. Picolet, 19 South Ninth street, Philadelphia, Pa. This rule is made of pyroxyline, a material frequently used for draftsman's triangles. It has a diameter of 2¾ in. and a thickness of 3/32 in. It performs the operations of multiplication, division and the extractions of square and cube root. It is made with either of two scales. One scale is a direct arrangement for multiplication, division and square root in the usual way, and the other is inverted and has an auxiliary scale or cube root. The rule can be obtained with both scales if desired. This is a practical instrument which is claimed to be equivalent to three-place logarithms in precision.

CHANNEL PASSENGERS.—The cross-channel passenger traffic via Dover and Folkestone last year was 1,100,529.



## LOCOMOTIVE FIRE DOOR

A new type of locomotive fire door which has creditably passed severe tests on the Ann Arbor Railroad is shown in the accompanying illustrations.

It is hinged at the top and swings inward, being normally

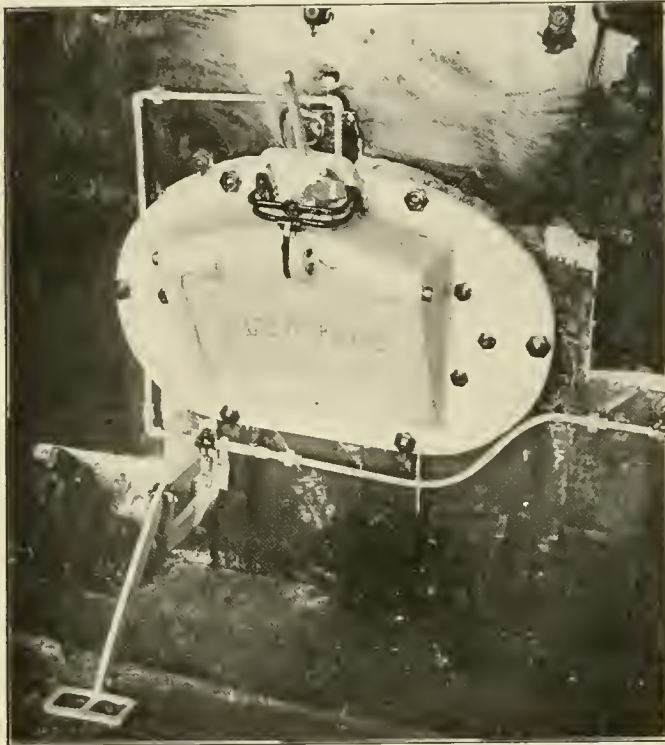

Door Closed and Held In Position by Gravity

operated by an air cylinder located on the shelf directly above the door. When closed, it rests against the inside of substantial flanges on both the sides and the bottom and, when opened,

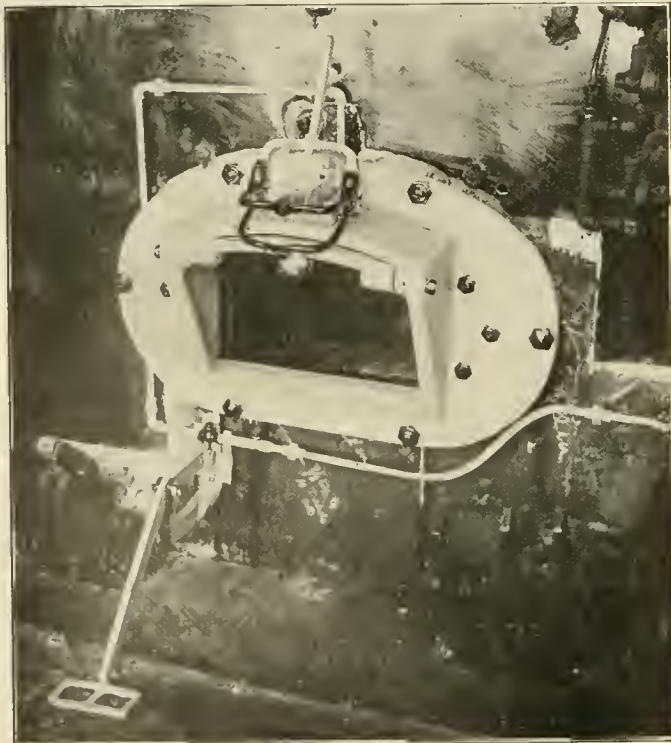

Door Swung Inward Around Hinge to the Full Open Position

swings to a horizontal position inside the casing. In the closed position, it rests at an angle so that it is held in place by gravity.

A hand operating device is provided in connection with the air cylinder and the door can be manipulated in the roundhouse when there is no air pressure on the locomotive or by the fireman in case of a break in the air line or other trouble. A lock is also arranged to hold the door in the open or the closed position as may be desired.

The air cylinder used is 2 in. in diameter and has a stroke of  $5\frac{1}{2}$  in., and is operated by a spring seated valve controlled by a foot pedal conveniently located as shown in the illustrations.

The advantages of this construction lie in the fact that in case of a broken arch tube or boiler tube, it will prevent the escape of steam or hot water to the cab. Furthermore, when in the open position it tends to deflect the air entering the door downward and under the arch. It has a further advantage in that the shelf over the top protects the fireman's face from the heat.

Application has been made for a patent covering this construction.

## COUNTERSINKING MACHINE

A combined drilling and countersinking device to operate in connection with a Little Giant drill has been developed by the Chicago Pneumatic Tool Company, Chicago, Ill. It is intended for countersinking on flanged tube sheets, door sheets, I-beams, etc., and is self-contained, requiring no rigging, back stop or feed screws.

The general arrangement of the machine is well shown in the illustration, where it will be seen that the feed is automatically regulated by means of an air chamber or push-up device

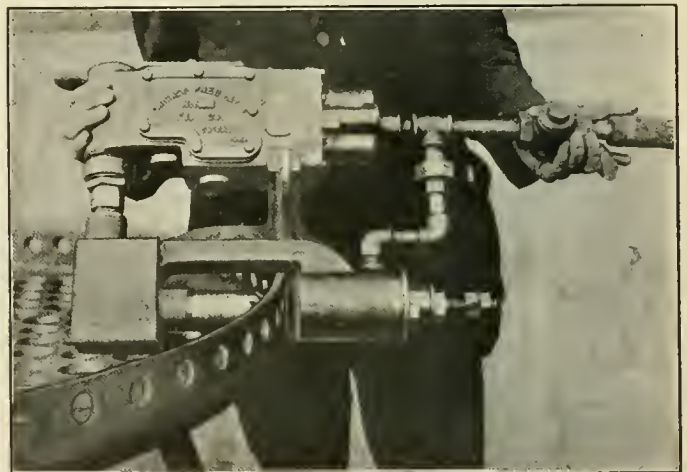

Device for Drilling and Countersinking Holes in Flanges

which has a connection directly to the air line behind the motor. Ball bearings are used throughout the device and the beveled gears are enclosed in an oil-tight chamber. A No. 4 Morse taper spindle is provided and the device is kept from turning by means of lugs which fit around the housing.

This machine weighs 35 lb. and it is claimed that flanged tube sheets may be countersunk at the rate of two holes a minute, as compared with a rate of one hole every two minutes under present methods.

**NATURAL GAS IN THE UNITED STATES.**—The Geological Survey reports that the consumption of natural gas exceeded all records in 1912, having amounted to 562,203,452,000 cu. ft., valued at \$84,563,957, or an average of 15.04 cents per 1,000 cu. ft. The corresponding consumption in 1911 was 512,993,021,000 cu. ft., valued at \$74,621,534, or an average of 14.55 cents per 1,000 cu. ft. in 1911.

# NEWS DEPARTMENT

For the purpose of reducing the number of accidents at highway crossings the Chicago & North Western, at the recommendation of its Central Safety Committee, is putting up a large number of special warning signs 400 or 500 ft. from the track at crossings where the view of approaching trains is materially obstructed. Approximately 500 of these signs have been set up at crossings in Illinois and Iowa.

The Union Pacific has abolished the title of assistant general manager held by the heads of departments on the general manager's staff under the Hine system of organization, retaining the distinctive titles of superintendent of motive power and machinery, chief engineer, superintendent of transportation, etc. Under the statutes it is necessary to have a distinctive title for some departments. Heretofore the road has used both titles and only the one legally required is to be retained. There will be no change in work or responsibilities.

Not a single passenger out of 111,000,000 carried by the Pennsylvania Railroad in 1913 was killed in a train accident. Reports for the past six years show that almost 600,000,000 passengers have been carried by the Pennsylvania, and but 16 of them lost their lives in accidents to trains; nine were killed in one accident. In six years, out of approximately 5,000,000 trains operated, about 1,370 a day—only five have been involved in wrecks which caused the death of any of the passengers carried on them. Three of these years were entirely free from train accidents causing the death of passengers.

A whole mountain of earth is being sent East from California over the Southern Pacific. It is situated near Lompoc, but the state of Pennsylvania wants it and is willing to pay the price for it, so that it is being shipped a matter of 3,000 miles by rail at the rate of 15 cars, or 750 tons, a month. When the last car has gone out an accurate indication will be had of what a mountain actually weighs. The earth is of a very peculiar consistency, and is supposed to be the result of gradual decomposition for ages past of millions of sea shells. For commercial use, the only process it goes through is grinding. It is sold in the East as insular earth, and has high value for insulating purposes in the electrical industry.

## A CORRECTION

The caption under the upper illustration in Mr. McManamy's paper on page 13 of the January issue should be "Result of a Boiler Explosion Caused by Low Water."

## THE TELEPHONE VOICE

The "campaign of politeness" on the Southern Pacific includes little placards attached to the telephone stands in the offices of the company. These "reminders" convey the following advice: "When you answer the telephone, be pleasant. It costs you nothing and in your heart you want to be liked. As you take off the receiver, say, 'Southern Pacific,' and then give your name or department. It saves time. Said pleasantly, it is a good advertisement for yourself and the company. Thank the man who helps you or gives you information—he likes it. Remember, on the telephone, the voice is everything. See that it is friendly."

## SAFETY FIRST ON THE NEW HAVEN

A "safety first" meeting was held at Boston on Sunday, January 25, at which over two thousand men were present. They were addressed by Howard Elliott, chairman of the board of directors of the New York, New Haven & Hartford; James H. Hustis, president of that road, and other officers. Mr. Elliott

said: "You have been accustomed to working with a list of 'don'ts' and I shall now give you a list of 'do's.'"

"Do be careful. Do be alert and efficient. Keep always in good mental and physical health. Do be loyal, and stand up for the railroad in a manly fashion. Be ready always to give courteous and direct answers to the public. Show the public that it has a duty toward us."

Mr. Hustis, in the course of his address, said: "Charges have been made that organized labor was in part responsible for the terrible accidents that have taken place on our railroad. I want to take this opportunity to say that organized labor, as such, cannot be charged with intentionally taking a position that will tend to increase accidents."

## PROPOSED STANDARD SIZE OF CATALOGS

Most catalogs at the present day are valuable, and are supplied to a carefully selected list of men to whom their contents will be of practical assistance. In the mechanical field particularly a great reliance is placed on the file of catalogs maintained, which in effect becomes a reference library. When one considers the multiplicity of sizes in use, the advantage of a standard size is at once demonstrated. A committee appointed by the Technical Publicity Association to investigate and recommend standard sizes for catalogs, recently measured 927 catalogs and found 147 different sizes, ranging from 3 in. by 5 in. to 11 in. by 14¼ in. This matter has been under investigation by the committee of the Technical Publicity Association for the past 18 months, and its investigations have led to the recommendation of 6 in. by 9 in. and 8½ in. by 11 in. for standards for all purposes. Both of these sizes will cut to very good advantage with a minimum of waste from catalog papers now carried in stock by paper manufacturers. Another advantage of the larger size is that catalogs of these dimensions can conveniently be filed with correspondence, as this size will very nicely fit standard filing cabinets.

## BALTIMORE & OHIO SAFETY COMMITTEE

The Baltimore & Ohio has reorganized its "safety-first" work and has established a general safety committee of seven members who are to give their whole time to this work. The chairman is J. G. Pangborn, and the other members are E. R. Scoville, John Hair, W. M. Bond, J. P. Campbell, Dr. E. M. Barlett and B. C. Craig. The three men who have been managing the safety-first work during the past three years, Messrs. Boyd, Coon and Tearney, are now an advisory committee. The new general committee will visit each division of the road on one day each month, to confer with local committeemen and to inspect the property. Major Pangborn is the well-known historian and former traffic officer of the Baltimore & Ohio. Mr. Scoville was for 12 years a division superintendent west of the Ohio river. Mr. Hair has been in the mechanical department since 1897 as master mechanic and superintendent of motive power. Mr. Bond was formerly a division engineer, Mr. Campbell a station agent and Dr. Barlett in the relief department. Mr. Craig for the past nine years has been inspector of safety appliances in the employ of the Interstate Commerce Commission.

## PASSENGER TRAINS ABOUT SAN FRANCISCO

The great number of Southern Pacific passenger trains operated daily within a radius of 50 miles from San Francisco is shown in figures compiled in the office of General Superintendent J. M. Davis of the Central District. On the Coast line—San Jose, San Bruno, Mayfield, Los Gatos—there are 73 trains daily, from Monday to Friday; 74 on Saturdays and 55 on Sun-



days. On the Transbay lines—Oakland through Port Costa; Oakland-Niles-Newark; Redwood-Niles and Niles-San Jose—there are 86 daily from Monday to Friday, and an equal number on Saturdays and Sundays. On the Vallejo-Suisun-Calistoga-Santa Rosa there are 24 daily.

On the electric suburban system there are 1,156 trains handled daily between Monday and Friday; 1,205 on Saturdays and 1,180 on Sundays.

On the steam suburban lines—Shellmound to Richmond and to Stonehurst—there are 34 daily except Sundays, when there are 31.

The total is 1,373 daily between Monday and Friday; 1,423 on Saturdays and 1,376 on Sundays.—*Southern Pacific Bulletin.*

**REPORT ON SMOKE ABATEMENT IN CHICAGO**

The Chicago Association of Commerce Committee on Smoke Abatement and Electrification of Railway Terminals has submitted a report to the association stating it has practically completed its investigation of the situation with respect to smoke in Chicago, but it has not completed its studies as to the remedy. The report says in part: "Meanwhile the committee is actively at work upon a program of study and design touching the important problems affecting the technical practicability and the cost of complete electrification. This is a problem presenting many details, each one of which is receiving careful and systematic attention.

"Studies are being made also concerning the financial practicability of carrying out the necessarily extensive program for electrification of the railway terminals of Chicago, in the event that such electrification shall be recommended in the committee's report.

"In conclusion, it may not be amiss to say that most of the materials necessary to solve the question of the necessity for the electrification of Chicago's railway terminals and the mechanical feasibility of such electrification are in hand, but that the information so far gathered as to the financial practicability of such an undertaking is not sufficient at the present time to enable the committee to determine this phase of the problem."

**MEETINGS AND CONVENTIONS**

*Master Boiler Makers' Association.*—The eighth annual convention of the Master Boiler Makers' Association will be held at the Hotel Walton, Philadelphia, Pa., which will be headquarters, on May 25, 26, 27 and 28, 1914.

*American Society of Mechanical Engineers.*—A paper on Brake Performance on Modern Steam Railroad Passenger Trains will be presented by S. W. Dudley, assistant chief engineer, Westinghouse Air Brake Company, Pittsburgh, Pa., on Tuesday, February 10, 1914, at 8:15 p. m., at 29 West Thirty-ninth street, New York. The data to be presented are the result of important tests made by the Pennsylvania Railroad, in conjunction with the Westinghouse Air Brake Company, during the past year. Among the more important topics are the following: The maximum percentage of emergency braking power which can be adopted; a comparison of the relative performance of the clasp brake rigging (two shoes per wheel) and the standard brake rigging (one shoe per wheel) under corresponding conditions; a comparison of the performance of the improved brake mechanism (type U C) with

that of the commonly used "high speed" (type P M) brake equipment; behavior of brake shoes as tests progressed and any variation in the result of similar tests which cannot be accounted for by known changes independent of the brake shoes; and the coefficient of friction between the wheel and the rail under varying weather conditions. After the presentation of the paper the meeting will be open for discussion. An informal dinner (a la carte) will be served at 6:30 p. m. Those desiring to participate should notify H. R. Cobleigh, 505 Pearl street (telephone 4200 Worth), New York, before February 9, and are requested to meeting in the society's rooms at 6:15 p. m.

*Air Brake Association.*—The twenty-first annual convention of the Air Brake Association will be held at the Hotel Pontchartrain, Detroit, Mich., May 5-8, 1914. The subjects are as follows: Electro-Pneumatic Signal System for Passenger Trains, by L. N. Armstrong; Air Hose, by T. W. Dow; Clasp Type of Foundation Brake Gear for Heavy Passenger Equipment Cars, by T. L. Burton; Air Gage and Conductor's Valve in Caboose Cars, by Mark Purcell; Analysis of the Factors Involved in Controlling and Stopping Passenger Trains, by Walter V. Turner; 100 Per Cent Efficiency of Freight Train Brakes, by Fred von Bergen; Recommended Practice, S. G. Down, committee chairman; Topical Subjects, Mountain Grade Work, by H. H. Forney, and Modern Train Braking, by George W. Nolan. Among the entertainment features of the convention will be a "Manufacturers' Exploitation Meeting." One afternoon will be set aside for the members to assemble in the convention hall, where each exhibitor will be given from 15 to 30 minutes in which to exploit, by discourse, charts or lantern slides, or in any manner he chooses, the product or device which he desires to place before the assemblage. The executive committee inaugurates this convention novelty, believing that it will assist the booth exhibits, and also give the members an orderly account of what the exhibitors are contributing to the air brake art.

*The following list gives names of secretaries, dates of next or regular meetings, and places of meeting of mechanical associations.*

- AIR BRAKE ASSOCIATION.—F. M. Nellis, 53 State St., Boston, Mass. Convention, May 5-8, 1914, Detroit, Mich.
- AMERICAN RAILWAY MASTER MECHANICS' ASSOC.—J. W. Taylor, Karpen building, Chicago. Convention, June 15-17, 1914, Atlantic City, N. J.
- AMERICAN RAILWAY TOOL FOREMEN'S ASSOCIATION.—A. R. Davis, Central of Georgia, Macon, Ga.
- AMERICAN SOCIETY FOR TESTING MATERIALS.—Prof. E. Marburg, University of Pennsylvania, Philadelphia, Pa.
- AMERICAN SOCIETY OF MECHANICAL ENGINEERS.—Calvin W. Rice, 29 W. Thirty-ninth St., New York. Railroad session, February 10, 1914.
- CAR FOREMEN'S ASSOCIATION OF CHICAGO.—Aaron Kline, 841 North Fiftieth Court, Chicago; 2d Monday in month, Chicago.
- CHIEF INTERCHANGE CAR INSPECTORS' AND CAR FOREMEN'S ASSOCIATION.—S. Skidmore, 946 Richmond street, Cincinnati, Ohio.
- INTERNATIONAL RAILWAY FUEL ASSOCIATION.—C. G. Hall, 922 McCormick building, Chicago. Convention, May 18-22, 1914, Chicago.
- INTERNATIONAL RAILWAY GENERAL FOREMEN'S ASSOCIATION.—William Hall, 829 W. Broadway, Winona, Minn. Convention, July 14-17, 1914, Hotel Sherman, Chicago.
- INTERNATIONAL RAILROAD MASTER BLACKSMITHS' ASSOCIATION.—A. L. Woodworth, Lima, Ohio. Convention, August 18-20, 1914, Milwaukee, Wis.
- MASTER BOILER MAKERS' ASSOCIATION.—Harry D. Vought, 95 Liberty St., New York. Convention, May 25-28, 1914, Philadelphia, Pa.
- MASTER CAR BUILDERS' ASSOCIATION.—J. W. Taylor, Karpen building, Chicago. Convention, June 10-12, 1914, Atlantic City, N. J.
- MASTER CAR AND LOCOMOTIVE PAINTERS' ASSOC. OF U. S. AND CANADA.—A. P. Dane, B. & M., Reading, Mass.
- RAILWAY STOREKEEPERS' ASSOCIATION.—J. P. Murphy, Box C, Collinwood, Ohio.
- TRAVELING ENGINEERS' ASSOCIATION.—W. O. Thompson, N. Y. C. & H. R., East Buffalo, N. Y. Convention, August, 1914, Chicago, Ill.

**RAILROAD CLUB MEETINGS**

Club.	Next Meeting.	Title of Paper.	Author.	Secretary.	Address.
Canadian .....	Feb. 10	The College Man and the Railroads.....	J. S. Hall.....	Jas. Powell .....	Room 13, Windsor Hotel, Montreal.
Central .....	Mar. 12	Interchange Rules .....	H. M. Butts.....	H. D. Vought....	95 Liberty St., New York.
New England....	Feb. 10	Steel Passenger Car Construction.....	F. M. Brinkerhoff..	Wm. E. Cade....	683 Atlantic Ave., Boston, Mass.
New York .....	Feb. 20	Development in Railway Signal Glass.....	Wm. Churchill.....	H. D. Vought....	95 Liberty St., New York.
Pittsburgh .....	Feb. 27	Malleable Iron Pipe Fittings.....	J. C. Bannister.....	J. B. Anderson....	207 Penna. Station, Pittsburgh, Pa.
Richmond .....	Feb. 9	Wrought Iron vs. Steel Tubes.....	J. A. Kincaid.....	F. O. Robinson....	C. & O. Ry., Richmond, Va.
St. Louis .....	Feb. 13	.....	Slason Thompson....	B. W. Frauenthal..	Union Station, St. Louis, Mo.
Western .....	Feb. 17	.....	W. E. Dunham.....	Jos. W. Taylor....	1112 Karpen Bldg., Chicago.

## PERSONALS

*It is our desire to make these columns cover as completely as possible all the changes that take place in the mechanical departments of the railways of this country, and we shall greatly appreciate any assistance that our readers may give us in helping to bring this about.*

### GENERAL

E. B. HALL, division master mechanic of the Chicago & North Western at Chicago, has been appointed assistant to the general superintendent of motive power and car departments, with headquarters at Chicago.

ALONZO G. PACK, district inspector of locomotive boilers for the Interstate Commerce Commission at Denver, Col., has been appointed assistant chief inspector, with headquarters at Washington, D. C., succeeding Frank McManamy, promoted.

FRANK McMANAMY has been appointed chief inspector of locomotive boilers for the Interstate Commerce Commission, with headquarters at Washington, D. C., succeeding J. F. Ensign, deceased.

J. W. SASSER, master mechanic of the Seaboard Air Line, at Jacksonville, Fla., has been appointed superintendent of motive power of the Norfolk Southern, with office at Norfolk, Va.

### MASTER MECHANICS AND ROAD FOREMEN OF ENGINES

C. D. ASHMORE, general foreman of the Chicago & North Western at Clinton, Iowa, has been appointed master mechanic at Pekin, Ill., a newly created position.

WM. BAKER has been appointed road foreman of engines of the Lehigh Valley, with office at Wilkes-Barre, Pa.

J. A. BARKER has been appointed road foreman of engines of the Chesapeake & Ohio of Indiana, with office at Peru, Ind.

J. D. BELTZ has been appointed road foreman of engines of the Baltimore & Ohio at Pittsburgh, Pa.

JOHN BENZIES, supervisor of locomotive operation of the Missouri and Des Moines Valley divisions of the Rock Island Lines, with office at Chicago, has had his jurisdiction extended over the West Iowa division.

F. W. BOARDMAN has been appointed master mechanic of the Baltimore & Ohio at Eastside, Philadelphia, Pa., succeeding W. Sennott.

J. A. CASSADY has been appointed master mechanic of the Alabama Great Southern, with office at Birmingham, Ala.

B. F. CROWLEY has been appointed supervisor of locomotive operation of the Baltimore & Ohio, with headquarters at Wheeling, W. Va., succeeding T. B. Burgess.

W. A. CURLEY has been appointed master mechanic of the Missouri Pacific at Monroe, La., succeeding W. J. McKiernan.

F. S. DEVENY has been appointed road foreman of engines of the Baltimore & Ohio, with office at Chicago Junction, Ohio.

J. G. DOLE has been appointed master mechanic of the Alliance division of the Chicago, Burlington & Quincy, with headquarters at Alliance, Neb., succeeding T. J. Raycroft, resigned.

G. N. GAGE has been appointed assistant road foreman of engines of the Baltimore & Ohio, with headquarters at Rockwood, Pa.

E. J. GARRETT has been appointed road foreman of equipment of the Missouri & North Arkansas, with the additional duties of inspector of locomotive fuel performance, with office at Harrison, Ark.

J. I. KEIPER has been appointed road foreman of engines of the Lehigh Valley, with headquarters at South Easton, Pa., succeeding John Roney.

H. KUGLER has been appointed road foreman of engines of the Lehigh Valley, with office at Buffalo, N. Y.

WILLIAM LANON has been appointed supervisor of locomotive operation of the Arkansas, Indian Territory and Louisiana divisions of the Rock Island Lines, with headquarters at Little Rock, Ark., succeeding S. T. Patterson, transferred.

J. W. NEILL has been appointed district master mechanic of the Canadian Pacific at Moose Jaw, Sask., succeeding J. P. McAnany.

T. NICHOLSON has been appointed master mechanic of the Louisiana Railroad & Navigation Company at Shreveport, La., succeeding M. F. McCarra, resigned.

J. O'CONNOR, assistant master mechanic of the Staten Island Rapid Transit, and the Staten Island Railway at Clifton, Staten Island, N. Y., has been appointed master mechanic, with headquarters at Clifton, and his former position has been abolished.

H. H. PARKER has been appointed master mechanic of the Seaboard Air Line at Jacksonville, Fla.

S. T. PATTERSON has been appointed supervisor of locomotive operation of the Chicago Terminal, Illinois and East Iowa divisions of the Rock Island Lines at Chicago, Ill., succeeding R. E. Wallace.

B. POWERS has been appointed road foreman of engines of the Detroit, Toledo & Ironton, with office at Springfield, Ohio.

C. B. RANDALL has been appointed master mechanic of the Missouri Pacific, with headquarters at Van Buren, Ark., succeeding W. A. Curley.

EDWARD ROBERTSON has been appointed road foreman of equipment of the Arkansas division of the Rock Island Lines, with headquarters at Little Rock, Ark., succeeding H. L. Foster.

J. H. WATTERS, master mechanic of the Georgia Railroad at Augusta, Ga., has resigned after 43 years of continuous railway service, to devote his time to other work. A portrait of Mr. Watters and a sketch of his railway career were published in the Railway Age Gazette, Mechanical Edition, October, 1913, page 573. The position of master mechanic has been abolished.

F. W. WILSON has been appointed supervisor of locomotive operation of the Cedar Rapids, Minnesota and Dakota divisions of the Chicago, Rock Island & Pacific, with headquarters at Cedar Rapids, Iowa.

### CAR DEPARTMENT

OSCAR ANDERSON has been appointed car foreman of the Great Northern at Skykomish, Wash., succeeding W. E. Johnston.

JOHN S. COOPER has been appointed car foreman of the Rock Island Lines at Hulbert, Ark., succeeding W. K. Smith.

F. H. EDMONDS has been appointed traveling car inspector of the Missouri Pacific, with office at Little Rock, Ark., succeeding C. F. Mase.

J. FLETCHER has been appointed car foreman of the Rock Island Lines at Armourdale, Kan., succeeding George McDonald.

E. W. HARTOUGH has been appointed car foreman of the Missouri, Kansas & Texas at St. Louis, Mo.

JOHN H. HAWKINS has been appointed car foreman of the Rock Island Lines at Pratt, Kan., succeeding C. R. McArthur.

G. F. HENNESSEY has been appointed general car and locomotive foreman of the Chicago, Milwaukee & St. Paul at Marion, Iowa.

W. C. LINDER has been appointed car foreman of the Pennsylvania Railroad at Shire Oaks, Pa., succeeding J. E. Ruff.

C. F. MASE has been appointed general foreman, car department, of the Missouri Pacific, with headquarters at Argenta, Ark.



C. R. McARTHUR has been appointed car foreman of the Rock Island Lines at St. Louis, Mo., succeeding J. Fletcher.

GEORGE McLEAN has been appointed car foreman of the Chicago Great Western at Oelwein, Iowa, succeeding W. R. Lutem.

F. T. SUMMERS has been appointed general car foreman of the Baltimore & Ohio at Garrett, Ind., succeeding J. H. Agar.

#### SHOP AND ENGINE HOUSE

F. S. ANTHONY, mechanical superintendent of the Texas & Pacific at Marshall, Tex., has resigned.

L. E. BOLINE has been appointed foreman boilermaker of the Rock Island Lines at Pratt, Kan., succeeding J. W. Greenly.

LEE CHAPMAN, division foreman of the Chicago & North Western at Norfolk, Neb., has been appointed division foreman at Chadron, Neb., succeeding W. H. Halsey, transferred.

J. P. COONEY has been appointed locomotive foreman of the Great Northern at Casselton, N. D., succeeding J. T. Muringer.

WILLIAM A. CULL has been appointed roundhouse foreman of the Atchison, Topeka & Santa Fe at Silsbee, Tex., succeeding F. J. Mannix.

A. J. CUNNINGHAM has been appointed foreman of the Atchison, Topeka & Santa Fe at Barstow, Cal.

C. R. FRYANT has been appointed shop foreman of the Chicago & North Western at Wyeville, Wis., succeeding G. Schimming.

W. H. HALSEY, division foreman of the Chicago & North Western at Chadron, Neb., has been appointed general foreman at Missouri Valley, Iowa, succeeding George H. Logan, promoted.

J. B. HASLET has been appointed locomotive foreman of the Great Northern at Breckenridge, Minn., succeeding William Krier.

ALBERT LODOR has been appointed foreman boilermaker of the Rock Island Lines at Biddle, Ark., succeeding P. J. Donohue.

GEORGE H. LOGAN, general foreman of the Chicago & North Western at Missouri Valley, Iowa, has been appointed general foreman at Clinton, Iowa, succeeding C. D. Ashmore, promoted.

J. W. McDONOUGH has been appointed roundhouse foreman of the Erie, at Kent, Ohio, succeeding P. J. Gallagher.

R. S. MENNIE has been appointed engineer of shop improvements of the Rock Island Lines, with headquarters at Chicago, succeeding W. J. Eddy, promoted.

J. MURPHY, division foreman of the Chicago & North Western at Tremont, Neb., has been appointed division foreman at Norfolk, Neb., succeeding Lee Chapman, transferred.

T. NASH has been appointed general foreman of the Baltimore & Ohio at Holloway, Ohio, succeeding H. Ainscough.

S. OLSON, general shop foreman of the Oregon Short Line at Ogden, Utah, has been transferred in that capacity to Pocatello, Idaho.

F. C. SIMPSON has been appointed general foreman of the Southern Railway at Asheville, N. C., succeeding E. L. Adams.

F. STAMELIN, shop foreman of the Canadian Pacific at Winnipeg, Man., has been appointed night locomotive foreman at that point, succeeding J. Morton, transferred.

J. E. STONE has been appointed general foreman of the Oregon Short Line at Ogden, Utah.

H. WITTE, roundhouse foreman of the Chicago & North Western at South Omaha, Neb., has been appointed division foreman at Tremont, Neb., succeeding J. Murphy, transferred.

## SUPPLY TRADE NOTES

C. H. Schlacks has been elected president of the Hale & Kilburn Company, Philadelphia, Pa.

John F. Schurch has been elected vice-president of the Damascus Brake Beam Company, Cleveland, Ohio.

Kelly R. Johnston, formerly with the National Malleable Castings Company, Cleveland, Ohio, has been appointed sales agent of the locomotive headlight department of the Remy Electric Company, Anderson, Ind.

A. Reiche, formerly general manager of the Orenstein Arthur Koppel Company's plant and general offices at Koppel, Pa., sailed for Germany, January 14, and has been succeeded by Erich Joseph, formerly New York manager of that company.

The Jerguson Manufacturing Company, Boston, Mass., has changed its name to the Wiltbonco Manufacturing Company. The company, which is engaged in the manufacture of Wiltbonco locomotive and boiler specialties, will remain at the same address and continue under the same management.

William Cooper, director of buildings and equipment at the East Pittsburgh works of the Westinghouse Electric & Manufacturing Company, died on January 23. Mr. Cooper was born

near Watertown, N. Y., on November 24, 1861. He attended Cornell University and began in business with a cheese manufacturing firm, having charge of the power plant. At the age of 25 he went to Ottumwa, Ia., to engage in the building of automatic screw machines. Soon after he started a shop in Minneapolis for himself, undertaking the development of a compressed air traction system. He was thus led to the investigation of the hydraulic speed changing gear now manufactured by the Waterbury Tool Company, Waterbury, Conn.,



W. Cooper

and used for moving the turrets on battleships. Mr. Cooper then entered the employ of the Twin City Rapid Transit Company, Minneapolis, being master mechanic and chief engineer for four years. In 1894 he went to the General Electric Company, and during his stay at Schenectady supervised the manufacture of the locomotives for the Baltimore & Ohio terminal at Baltimore, being detailed to put them into service after their erection. After the completion of this work he became associated with Blood & Hale, consulting engineers, Boston, Mass. On September 1, 1897, he entered the employ of the Bullock Electric & Manufacturing Company, Cincinnati, Ohio, and general superintendent in charge of engineering and manufacturing. In 1904 he entered the railway engineering department of the Westinghouse Electric & Manufacturing Company. His first work was to investigate the unit switch control, which the company was then exploiting. Following that he was appointed engineering inspector. He was also one of the members of the verification committee. Two years ago, when the works department was organized, he was made director of buildings and equipment. In addition to other work in the railway field he was active in the design and manufacture of the equipment fur-

nished the several roads which have been electrified by the Westinghouse company.

The Pullman Company has announced the establishment of a pension plan providing for the retirement of employes at the age of 70, or after 20 years of service in case of disability, with a pension equal to 1 per cent for each year of service of the average rate of pay for the last year of service. No one over 45 years of age will be taken into service hereafter except by special arrangement. The pension plan will be administered by a board of pensions, consisting of Richmond Dean, general manager, chairman; William Hough, auditor; Leroy Kramer, assistant to the president; L. S. Hungerford, general superintendent, and L. S. Taylor, treasurer. The company has about 33,000 employes.

The Franklin Railway Supply Company, New York, because of growth in business has been compelled to enlarge and reorganize its sales department. Walter H. Coyle has been elected second vice-president in charge of sales. William L. Allison will remain in charge of the company's office at Chicago as western sales manager. J. H. Steiger will continue in charge of sales on the Pacific coast, with office in San Francisco, as will also Pedro M. Armendariz in charge of sales in Mexico with office in Mexico City. Ralph G. Coburn has been promoted to eastern sales manager, and Alan Lichtenhein to Canadian sales manager, both with offices at 30 Church street, New York.



Walter H. Coyle

Walter H. Coyle was born at Salamanca, N. Y., December 27, 1878. Four years later his family removed to Meadville, Pa., and Mr. Coyle was educated in the public schools of that place. After leaving school he was for 11 years in the service of the Erie Railroad in various capacities in the mechanical and traffic departments. In January, 1905, he became identified with the Kent Manufacturing Company, Kent, Ohio, and in June of the same year entered the mechanical department of the Franklin Railway Supply Company, with headquarters at Franklin, Pa. In June, 1911, he was made assistant to the vice-president, with headquarters at New York, and was placed in charge of the sales department of the central territory, which position he held until his election as second vice-president, as noted above.



Ralph G. Coburn

Ralph G. Coburn, who has been appointed eastern sales manager, with headquarters at New York, was born at Boston

in 1882. He graduated from Harvard in 1904, and entered the service of the American Glue Company. He remained with that company about four years, being in charge of its western factories and having his headquarters at Des Moines, Iowa, and Chicago. On May 1, 1909, he opened the Chicago office of the Franklin Railway Supply Company as resident sales manager. On June 1, 1911, he was made assistant to the vice-president, in charge of eastern-southern territory, with headquarters at New York, which position he held until his appointment as eastern sales manager.



Alan Lichtenhein

Alan Lichtenhein was born May 24, 1887, and is a graduate of both Williams College and the Harvard Law School. Upon the death of his father, who for many years occupied a very prominent position in the Canadian railway supply field, he entered the service of the Franklin Railway Supply Company in Canada, and now succeeds to his father's position in charge of Canadian sales of that company.

Elmer E. Allbee resigned from his position as mechanical superintendent of the Safety Car Heating & Lighting Company, New York, on January 1. Mr. Allbee graduated from the University of Vermont in 1889. He entered the employ of the Safety Car Heating & Lighting Company in 1890, and has held the position of mechanical engineer and mechanical superintendent for the last 11 years.

At the annual meeting of the directors of the American Arch Company, John P. Neff and William L. Allison were elected vice-presidents.

Mr. Neff was born at La Fontaine, Ind., May 2, 1874. In 1895 he was graduated from the mechanical engineering department of Purdue University and entered the service of the Chicago & North Western as a special apprentice. During the greater part of his special apprenticeship he was in charge of the locomotive testing plant where a very considerable amount of research work was being carried on. Following this he served as a machinist; assistant roundhouse foreman at Chicago; division foreman of the motive power department at Waseca, Minn., October, 1899, to May, 1901; master mechanic at Huron, S. D., May, 1901, to September 1902; master mechanic of the Western Iowa division, with headquarters at Boone, Iowa, September, 1902, to July, 1904. In 1904 he left railroad service to take a position as engineer of tests



J. P. Neff



of the American Locomotive Equipment Company. In 1906 he was made mechanical engineer of that company, and succeeded to a similar position with the American Arch Company when it was formed in 1910. In March, 1912, he was made assistant to the president of the American Arch Company, which position he held until his recent election as vice-president.

William Locke Allison was born near Salisbury, N. C., March 20, 1876. He was educated at the Davis Military School, Winston-Salem, N. C., and received a United States Military Academy appointment, but did not graduate. He entered the government service as United States deputy marshal, which position he held for three and a half years. From March, 1898, to January, 1904, he was employed by the Baldwin Locomotive Works in various capacities, the last year of his service with that company being as engineer of tests. From January, 1904, to August, 1909, he was mechanical engineer of the Atchison, Topeka & Santa Fe, with headquarters at Chicago. In 1909 he became identified with the Franklin Railway Supply Company, and for two years was mechanical manager, with office at New York. Since that time he has been western sales manager, with office at Chicago, and has also been western sales manager of the Rome Merchant Iron Mills and the Economy Devices Corporation, and general western sales manager of the American Arch Company.

E. M. Chadwick, formerly with the Fairbanks Company, has been appointed manager of the Buffalo branch of Manning, Maxwell & Moore, New York. D. A. Hamilton, formerly with the Reed Prentice Company, of Worcester, has been appointed assistant at Manning, Maxwell & Moore's Detroit branch.

R. M. Campbell has been appointed special representative of the railway department in the eastern territory of the Detroit Graphite Company, Detroit, Mich., with headquarters at 135 Broadway, New York City. Mr. Campbell was for a number of years with the Ohio Brass Company and the Transportation Utilities Company.

B. S. McClellen, who for several years has had charge of the railway sales department of the McCord Manufacturing Company, Chicago, has resigned active connection with this company in order to give more personal attention to his other interests. A new company which he has just organized, the McClellen Nut Company, Chicago, will shortly place upon the market a one-piece self-locking nut, which will be known as the "Unit" lock nut, and which will do away with the use of the additional lock nut, thereby making possible the use of a shorter bolt. Mr. McClellen has had years of experience in the railway field, and is the inventor of over 30 improvements connected with car and locomotive work, many of which are standard on the largest systems in this country. He was for seven years general foreman of the New Orleans terminals of the Illinois Central in charge of both locomotive and car departments. He was at one time also general foreman of the passenger car department of the New York Central lines at West Albany, N. Y., and has been also master car builder of the Fort Worth & Denver City, Ft. Worth, Tex.



W. L. Allison

## CATALOGS

**PIPE UNION.**—A circular from the National Tube Company, Pittsburgh, Pa., presents the advantages of the Kewanee union in the form of an interview on the question and answer basis. It also illustrates in colors several designs of this type of union.

**MOTOR GEARS AND PINIONS.**—Railway motor gears and pinions are fully illustrated and described in bulletin No. A-4199 from the General Electric Company, Schenectady, N. Y. This bulletin contains curves and data which will be of especial interest to the designers of equipment using motors.

**ELECTRICITY IN IRON FOUNDRIES.**—Bulletin A-4167 from the General Electric Company, Schenectady, N. Y., is devoted to the subject of electricity in iron foundries, and is profusely illustrated with typical installations of motors in this department. A chapter is also given on foundry lighting.

**REAMERS.**—Catalog No. 4 on cost cutting tools for machine shops prepared by the McCrosky Reamer Company, Meadville, Pa., contains 59 pages devoted to an illustrated discussion of adjustable reamers, quick change chucks and collets, variable speed and reversing attachments especially suitable for drilling machines, expanding mandrels, universal lamp brackets for lighting machine tools, combination face-plates and dogs.

**SPEED RECORDER WITH CLOCK ATTACHMENT.**—Bulletin No. 166 from the Chicago Pneumatic Tool Company, Fisher building, Chicago, fully describes the latest improvement to the Boyer speed recorder which consists of the addition of a clock attachment so arranged as to record graphically the time at all points during the trip. This addition does not in any way affect the remainder of the machine. The chart from the new recorder then allows the following information to be obtained: speed in miles per hour, total mileage, actual running time between any and all points, total time on the road, time and location of each stop or slow-down, time consumed by each stop, time and location of each brake application, acceleration, rate of increase or decrease in speed between any two points. The catalog includes a sample section of the new chart.

**CAR LIGHTING FIXTURES.**—In compiling its car lighting catalog No. 166, the Dayton Manufacturing Company, Dayton, Ohio, has endeavored to illustrate and enumerate so far as practicable all the fixtures which its experience indicates to be needed for the efficient and artistic illumination of modern steam and electric railway cars. This catalog takes the form of a 158 page, cloth bound book with pages 9 in. x 12 in. The value of having good illustrations for a catalog of this nature has been fully appreciated and the book is given up very largely to views of the fixtures. Descriptive matter is included wherever necessary and a short section is devoted to a discussion of electric car lighting in general, with wiring diagrams. A type of shade holder that has been giving very excellent results in the saving of glassware and time is also described.

**MECHANICAL BELT SHIFTER.**—Under the title of "Safety-Commercialized," R. K. LeBlond Machine Tool Company, Cincinnati, Ohio, has prepared a leaflet devoted to a discussion of the danger of personal injury from the usual method of shifting a belt on machine tools and also to an illustrated description of a mechanical belt shifter which has been perfected by it. This shifter can be applied to belt driven machine tools of any kind or make. The principle on which it operates is a mechanically operated shifter for both the cone head on the machine and the one on the countershaft. These two are so connected that one operates in advance of the other, both being moved by a handle on the head of the machine. The shifter is said to be positive and rapid in its operation and to increase the life of the belt. The catalog is thoroughly illustrated.

# Railway Age Gazette

MECHANICAL EDITION

INCLUDING THE  
AMERICAN ENGINEER

PUBLISHED ON THE FIRST THURSDAY OF EVERY MONTH BY THE  
SIMMONS-BOARDMAN PUBLISHING COMPANY,  
WOOLWORTH BUILDING, NEW YORK, N. Y.

CHICAGO: Transportation Bldg. CLEVELAND: Citizen's Bldg.  
LONDON: Queen Anne's Chambers, Westminster.

EDWARD A. SIMMONS, *President* L. B. SHERMAN, *Vice-President*  
HENRY LEE, *Secretary*

The address of the company is the address of the officers.

ROY V. WRIGHT, *Editor*

E. A. AVERILL, *Managing Editor* A. C. LOUDON, *Associate Editor*  
R. E. THAYER, *Associate Editor* GEORGE L. FOWLER, *Associate Editor*

Subscriptions, including the eight daily editions of the *Railway Age Gazette* published in June in connection with the annual conventions of the Master Car Builders' and American Railway Master Mechanics' Associations, payable in advance and postage free:

United States, Canada and Mexico.....	\$2.00 a year
Foreign Countries (excepting daily editions)....	3.00 a year
Single Copy .....	20 cents

Entered at the Post Office at New York, N. Y., as mail matter of the second class.

WE GUARANTEE, that of this issue 4,400 copies were printed; that of those 4,400 copies, 3,640 were mailed to regular paid subscribers and 150 were provided for counter and news companies' sales; that the total copies printed this year to date were 13,050—an average of 4,350 copies a month.

VOLUME 88

MARCH, 1914

NUMBER 3

## CONTENTS

### EDITORIALS:

Car Department Competition.....	111
Strength of Locomotive Boilers.....	111
Making Reports for the Government.....	111
\$100 for Data as to Best Type of Draft Gear.....	111
Lehigh Valley Locomotive .....	112
Electrification of Mountain Grades.....	112
Pennsylvania Brake Tests.....	113
New Books .....	114

### COMMUNICATIONS:

Jig for Grinding in Rotary Valves on E-T Equipment.....	115
Wiring for Electric Headlights.....	115
College Men and the Railroads.....	115

### GENERAL:

Lehigh Valley Pacific Type Locomotive.....	117
Advantages of Logarithmic Coordinate Paper.....	120
Reinforced Concrete Coaling Station.....	122
Strength of Locomotive Boilers.....	123
Training Men for Engine House Work.....	127
Buying Brushes on Specifications.....	128

### CAR DEPARTMENT:

Reclaiming Journal Box Packing.....	129
Foreign Car Question.....	130
Steel Freight Car Repair Shops.....	131
Refrigerator Car Design.....	135
Brake Performance on Passenger Trains.....	136

### SHOP PRACTICE:

Repairing Slide Valve Feed Valves.....	141
Improved Tool Holder and Center for Wheel Lathes.....	142
Tools for Locomotive Repairs.....	143
Installation and Maintenance of Electric Headlight Equipment.....	145
Smith Shop Tools.....	148
Autogenous Welding in Locomotive Fireboxes.....	149
The Apprentice—A Boy.....	150
Devices for Shop Use.....	151
Roundhouse Test Rack for Examining Lubricators.....	152
Tool for Setting Boiler Course Sheets.....	152

### NEW DEVICES:

High Speed Drill.....	153
Air Hose Protector.....	153
Economy Engine Truck.....	154
Low Water Alarm .....	155
Journal Cooler .....	155
A Novel Form of Wrench.....	156
Portable Grinder for Planers.....	156
Pyrometer for Superheater Locomotives.....	157
Socket Washer for Grab Irons.....	157
Heavy Duty Radial Drill.....	158
Adjustable Spacing Collar.....	158

### NEWS DEPARTMENT:

Notes .....	159
Meetings and Conventions .....	160
Personals .....	161
Supply Trade Notes.....	163
Catalogs .....	164

### Car Department Competition

The article on steel freight car repair shops prepared by E. T. Spidy, general shop foreman, Canadian Pacific, Winnipeg, Man., has been judged the winner of the car department competition which closed on February 1, 1914. Mr. Spidy's article is published in this issue and he has been awarded the prize of \$50. Several of the other articles submitted in the competition were of extremely high merit and have been accepted for publication. They will appear in later numbers.

### Strength of Locomotive Boilers

Boiler form No. 4 for the Interstate Commerce Commission requires something more than the mere filling out of existing records, as many of our readers realize. Careful calculations must be made and, when conscientiously done, result in a large amount of computation and search for suitable formulas. William N. Allman has had considerable experience in connection with filling out this form and has evolved a number of formulas to simplify the work which he explains in an article in this issue. While there may be some who will criticize his reasoning and object to his conclusions, still the fact remains that, for the first time, this whole matter has been put in such form as to be readily available for use in this connection. The tables he gives relating to the shearing value of rivets and the safe load on staybolts will, no doubt, be particularly appreciated.

### Making Reports for the Government

A mechanical engineer of one of the large western roads recently stated to a caller, "I am not really mechanical engineer of this road any longer. While I still carry the title, almost all of my time is now devoted to making reports required by the government, our own legal department or some smoke commission, when I am not attending hearings and committee meetings on the same subjects." Another motive power official of an eastern line recently remarked, "The matter that we were considering a month ago is still untouched as my entire time since that date has been devoted to answering a few of the questions requested by the Interstate Commerce Commission in connection with the rate hearing. The pile of papers you see there (a foot high) is part of the data I have been collecting." These are by no means exceptional instances, and on some roads the governmental activity in connection with railroads requires so much of the time of motive power officers that a special consulting engineer has been employed to devote his whole time to these matters. If the work of the department is to progress satisfactorily, the other roads will have to do the same thing and may eventually even have to organize a corps of men for this work.

### \$100 for Data as to Best Type of Draft Gear

One who has given the subject of draft gear for freight cars much thought and study is responsible for the statement that the use of inferior draft gears is costing the railways of this country 250 million dollars a year; this on the basis of the damage to equipment, the loss and damage to freight, delays to traffic due to defective equipment caused by inferior draft gears, and congestion at terminals due to bad order cars, etc. Is he right? Has he underestimated or overestimated the amount involved? There are less than two and a half million freight cars in this country.

For many years improved draft gears and friction draft gears have been in the course of development. It would seem from the great amount of attention which railroad men have given to the draft gear problem that there is little question but what the older types of gears are inadequate. Many thousands of freight cars are now equipped with the improved gears. The Master Car Builders' Association has tested the various types of gears under the drop testing ma-



chine and also by static tests in the laboratory. These results have been published broadcast, but the practical railway man has hesitated to place too much reliance upon them because the conditions under which the load was applied were so different from those encountered in actual practice. In a few cases railroads have made road tests, and these have contributed certain facts to our knowledge of the gears; but here, too, it is difficult to duplicate conditions in order to make comparative tests. Then, too, in all these tests the question enters as to whether the gears, tested when they were new, or practically so, would give equally as good results after they had been in service for a year or several years. Certain tests have been made by one or two of the railways and manufacturing concerns with special testing machines which are claimed to very nearly approximate service conditions in applying and releasing the load; the results of these tests, however, are not widely known and have never been available for publication.

After all, the results which are really worth while are those which are obtained in service. Here again, however, a serious difficulty is met with. Freight cars are so generally interchanged and spend so much time on foreign lines that it is hardly possible to keep an accurate check on them individually, as is the case with passenger cars and locomotives which seldom, if ever, leave the road or system. J. C. Fritts, master car builder of the Delaware, Lackawanna & Western, showed, however, in a paper on "Freight Car Troubles," which he read before the September meeting of the Central Railway Club, and which was published in the Railway Age Gazette, Mechanical Edition, for September, 1913, that it was possible to secure fairly accurate information as to the comparative service of different types of draft gears.

Many railroads have placed special draft gears on their equipment in fairly large quantities, and in a number of cases a large order of cars of the same design has been divided into several parts, each using a different type of draft gear. Surely, even if it is not possible on all roads to follow it up to the extent that Mr. Fritts did on the Lackawanna, the differences between the different types of gears, if they are as great as we have been led to believe, would be apparent by the difference in the repairs which are required by the different cars and in the physical condition of the cars after extended service. It would seem that the time has come when some of this data, of a fairly accurate and convincing nature, should be available. If there is so great a difference between the newer and older types of draft gear the fact should be given the widest publicity in order that the railways may protect themselves against the ever increasing expense to which they are subjected. So great is the importance of this subject that we propose to offer a prize of \$100 for the best article received in this office on or before May 15, 1914, on the draft gear problem. The subject may be discussed from any viewpoint, depending upon the experience and observations of the author; but the judges will base their decision on facts and evidence to show what types of draft gears are giving the best results. Articles not awarded the prize but accepted for publication will be paid for at our regular space rates.

**Lehigh Valley Locomotive**

It is seldom that an anthracite burning locomotive presents as pleasing an appearance as the Pacific type engines recently designed and built by the Lehigh Valley, which are illustrated and described in this issue. As will be seen by reference to the speed chart, these engines are capable of a rather remarkable performance and are now daily doing the work which formerly required two locomotives that, together, had a tractive effort fully 50 per cent greater than the new design. In keeping with the latest practice in respect to superheater locomotives, the factor of adhesion has been made rather low; in other words, the locomotives would appear to be over cylindered if judged by previous standards.

When, however, it is remembered that a superheater locomotive should work at a cut-off in the neighborhood of 30 per cent for the most efficient steam consumption at high speeds, the explanation of the ratio is clear. The designer of these locomotives has striven for a valve design and setting which will give an even turning movement at the crank pin and thus an even drawbar pull. How well he has accomplished this result is shown by one of the curves in the article which indicates that the turning movement varies but slightly for a full stroke, the power of both cylinders being considered. Similar curves from some other locomotives of the same size which have not been given the same study, show a surprising variation.

#### Electrification of Mountain Grades

An article by Joseph T. Ripley in the February 13 issue of the Railway Age Gazette gives a brief summary of a study made to determine the advantages, if any, of electrifying the 23-mile section of the Santa Fe between Trinidad, Col., and Raton, N. M. The Raton Mountain is about seven miles from Raton and 16 miles from Trinidad. The grades on this section are  $3\frac{1}{2}$  per cent opposed to westbound traffic from Trinidad to the summit and 3.32 per cent opposed to eastbound traffic. The maximum curvature is 10 deg. and it is estimated that about 50 per cent of the line is on curves. Of all the lines owned by the Santa Fe, this section seems to be the most susceptible to electrification with resultant economy and hence it was selected for this study. A careful analysis was made of the tonnage handled over the mountain, both daily, monthly and yearly. The average number of freight trains per day was assumed to be twelve, six in each direction, and there were eight passenger trains, four in each direction. The yearly tonnage was found to be 2,720,000 tons westbound and 1,915,000 tons eastbound.

In preparing the estimates, four sources of power supply were considered and four different electrical systems were studied and cost estimates were prepared for each with each of the different sources of power. These electrical systems consisted of direct current at 1,200 volts, direct current at 2,400 volts, single phase current at 11,000 volts and three phase current at 6,600 volts. In deciding the requisite power station capacity for each, the assumption was made that, at the time of congestion, it might be necessary to move simultaneously up grade at speeds of 12 and 15 miles an hour, respectively, two freight trains of 1,639 tons each and two passenger trains of 600 tons each. This led to the conclusion that in each of the four electrical systems a station containing four 3,000 k.w. units would be of ample capacity.

In arriving at the most economical size of electric locomotives to be used, time space diagrams were plotted for each of seven rated locomotive tonnage capacities, ranging from 300 to 600 tons conclusively, these diagrams being made on the basis of the average train tonnage during the month of May, 1912. It was finally concluded that thirteen 115 ton electric locomotives would handle the traffic to the best advantage with the minimum outlay of capital. Careful estimates, based on statistics available, were made of the expense for enginemen's wages and the cost of electric locomotive maintenance and repairs. In the latter case 4.06 cents, 4.85 cents and 5 cents per locomotive mile were assumed for a direct current, single phase and three phase system, respectively. Proper depreciation charges were also carefully fixed and other items of expense were conservatively estimated in accordance with available records of electrified trunk lines. It was finally ascertained that the use of a single phase system obtaining power from a plant constructed and operated by the railway and using coke oven gas as fuel, gave the highest return on the necessary capital invested. With this combination it was found that it would require nearly \$2,000,000 increase in capital charge after the cost of the steam locomotives, that would be replaced, had been subtracted.

The total annual operating expenses of the electric locomotives were found to be \$124,445 against \$244,398 for steam. The fixed charges, exclusive of interest, for the electric service were \$127,373 and for the steam service \$20,370. This gave a total of operating expenses and fixed charges, exclusive of interest, for the electric, \$251,818, and for the steam, \$264,768, a difference in favor of the electric of \$12,950. Since the plant was figured on the basis of the sale of electric power to a nearby manufacturing plant, which would bring in an income of \$50,000 a year, this gave the total difference in favor of the electric service of \$62,950 a year or 3.18 per cent return on the increased capital charge.

The study as a whole indicated that it would show a profit of any kind only in connection with a power plant constructed and operated by the railroad company. For the type of plant assumed above, using coke oven gas as fuel, it was found that the direct current at 1,200 volts would give a return of 1½ per cent annually on the capital, direct current at 2,400 volts would return 2.35 per cent, single phase 3.18 per cent and three phase 1.44 per cent. If coal was used as fuel for the same power plant, direct current at 1,200 volts would return .32 per cent, at 2,400 volts, .99 per cent, single phase would return 1.63 per cent, while the three phase would show a deficit of over \$2,000 a year. If power was purchased from outside sources deficits ranging from nearly \$4,000 to over \$62,000 a year were shown. In this connection it should be understood that the power plant would be located in a region where coal is cheap. The opportunity for using water power was considered, but did not prove feasible.

#### Pennsylvania Brake Tests

It is probable that Mr. Vaughan expressed the sentiments of every one who has had an opportunity of carefully reading the report of the tests of brake performance on passenger trains made by the Pennsylvania Railroad in 1913, when in discussing Mr. Dudley's paper before the recent meeting of the American Society of Mechanical Engineers, he said, "I feel that the United States ought to be proud of having a railroad company in its domain with energy enough and interest enough in the subject of brakes to devote time and money to such an extent as was necessary to carry out a series of tests of this kind, and also proud of the fact that any railroad company is equipped with a sufficient corps of trained men to take the observations required in the investigation reported in this paper. I think it is a magnificent testimonial to the scientific side of the operation of American railways and a credit to the whole country that the presentation of a paper like this should be at all possible." This, of course, is not the first time that the railroads of the country have been indebted to the Pennsylvania for thorough investigations of this kind. As has been stated in these columns before, the broad minded policy of the management in respect to the activity of the motive power department and the facilities possessed for making complete engineering investigations, places the Pennsylvania in an enviable position among the railroads of this country. It is probable that, unless the government organizes a bureau of railroads, similar to that it now has for mines, we will have to continue to look to the Pennsylvania for accurate engineering information on the operation of the latest important developments of broad scope on both locomotives and cars.

In fairness to those of our readers who may not be particularly interested in this subject, it has seemed advisable to devote only sufficient space in this issue to give a general outline of the character of the tests, the equipment used and the results obtained. Those who are interested in the details of the test can obtain copies of Mr. Dudley's paper or of the complete report from the Westinghouse Air Brake Company.

In the discussion of the paper T. J. Kelley, consulting air brake engineer of the New York Central Lines, pointed out that the percentage of braking power, if employed within

reasonable limits, is not necessarily in itself the cause of wheel sliding, especially with the ordinary design of truck and brake rigging. It is frequently due to the uneven distribution of the forces over the different wheels of the truck, and particularly of the different cars of the train. He points out that while the clasp brake gear will not dispense with the shock it will go a long way toward keeping the wheels in the truck about in their normal position with relation to other parts so that whatever spring action is available will tend to keep the wheel where it belongs and the rail adhesion uniform. Furthermore, he believes that the clasp brake will go a long way toward giving freedom from hot boxes because, with the modern percentage of braking power, with all the pressure on one side of the wheel, it brings a considerable thrust on the journal, which is often productive of heated bearings.

Mr. Vaughan in his discussion commented on the marvelous ingenuity of the whole apparatus in connection with the U. C. equipment, but suggested that it might be possible to design an electro-pneumatic brake which would be much simpler, provided it was not required that it should be interchangeable with the present equipment. He believed that it would not be a serious matter to carry two sets of brakes on the trains during the transition period, and pointed out the fact that in Europe cars which carry four sets of brakes are frequent. He asked where the railroads would be able to get men at 25 cents an hour who would be able to tell what was wrong with such a complicated equipment as that shown in the paper. He was frank in saying that, as a railroad man, he was afraid of this new equipment. While it is a beautiful piece of apparatus, if we could get a simple electric control (and it does not seem that the difficulties are insurmountable) and thus obtain a simple, cheap brake that the repair men can understand, on which they can locate the trouble and know what they are doing, it would be very much better than the equipment shown. Mr. Turner, chief engineer of the Westinghouse Air Brake Company, agreed with Mr. Vaughan in regard to having as simple an apparatus as possible, but stated that if it is desired to do the things which are necessary to control the trains today, particularly during the transition period, it is essential to have substantially the apparatus shown. He believes that the two or three brake equipments which would have to be carried according to Mr. Vaughan's idea, would be as complex as the U. C. equipment.

Some tests recently made on the New York, Westchester & Boston to determine the efficiency of the clasp brake rigging were quoted by R. R. Potter of that road. The electrically operated cars of this line weigh about 120,000 lb., and in making the tests motor trucks having clasp brakes were put under both ends of the car. From 35 miles an hour the deceleration in an emergency application was found to be 4 miles per hour per second with the clasp brake, while with the simple brake it was 3.3 miles per hour per second. At 50 miles an hour the clasp brake gave a deceleration of 3.55 miles per hour per second, while with the standard brake it was 3 miles per hour per second. The length of stop with the clasp brake at 50 miles an hour was 585 ft., while with the simple or standard brake it was 690 ft. This was the average length for about 40 stops.

S. G. Thomson, superintendent of motive power, Philadelphia & Reading, reported excellent service with the clasp brake on both six-wheel and four-wheel trucks on passenger coaches. He suggested that we get along for a few years without the electric brake by extending the use of the clasp brake.

Mr. Sargent suggested that the trouble which had followed the use of flanged brake shoes in connection with increased wheel sliding on some roads, was probably due to the fact that the brake rigging was not suitable for use with this type of shoe. The tests clearly indicate what the flanged shoe will do.

As an illustration of the difference in the requirements that brakes have to meet, Mr. Turner pointed out that in the year 1890 train weights seldom exceeded 280 tons which, with a speed of 60 miles an hour gave an energy to be dissipated of



about 33,000 foot-tons. Brakes used at that time stopped these trains in about 1,000 ft. In the year 1913 the train weight was 920 tons, and at the same speed the energy to be dissipated was 110,000 foot-tons, almost four times as large as that of the train in 1890. With a brake on this train of the same class as that used in the first one, the stopping distance would be 1,760 ft. The collision energy of this train as it passes the point where the first train stopped would still be 48,000 foot-tons, one and one-half times what the first mentioned train had before the brake was applied. The 920-ton train with the new brake apparatus can be stopped when running at a speed of 60 miles an hour in 860 ft., at which point, with the old brake, it would still be running 43 miles an hour. Mr. Turner further stated that while the illustrations no doubt impressed the uninitiated with their complexity and comparative size, when it is realized that the net result as measured by control requirements and stopping distance is but slightly greater in effectiveness than the old brake, it must be admitted that these things must be accepted on the ground that nothing less will suffice if reasonable capacity of track and rolling stock is to be had and general advance in transportation and safety are to keep pace.

### NEW BOOKS

*Master Car & Locomotive Painters' Proceedings, 1913 Convention.* Bound in paper, 132 pages. Size 6 in. x 9 in. Published by the Association, Alfred P. Dane, secretary, Reading, Mass.

The forty-fourth annual convention of the Master Car and Locomotive Painters' Association was held in Ottawa, Ont., September 9 to 12, inclusive. The proceedings contain the report of the test committee, which was of particular importance and interest, as well as papers giving the latest information on the finishing of steel passenger train equipment; safety in the paint department; rough inhibitive paint; protection of steel freight equipment, and economy in locomotive painting. The last mentioned includes a discussion of the present practice in locomotive painting.

*Machinery's Handbook.* Bound in flexible leather, 4½ in. by 7 in. 1370 pages. Illustrated. Published by the Industrial Press, New York. Price \$5.

This is a thoroughly complete reference book on machine design and shop practice intended for the mechanical engineer, draftsman, tool maker and machinist. While it is based largely on the data sheets issued by Machinery and the articles published in that magazine, much additional matter has been included by the compilers, Erik Obert and Franklin G. Jones. It would be impossible, in a review of this kind, to begin to convey an adequate idea of the amount of material contained in this book and it will suffice to say that it is complete so far as machine design and shop practice are concerned. Great pains have been taken to obtain a convenient arrangement of tables, data and text, and the plan of illustrating the use of formulas by examples, which are worked out, has been generally followed. It is believed to contain the best and most condensed treatises on gearing and springs that exist and the sections on heat treatment of steel, properties of material, motor power of machine tools, and screw threads are excellent. The compilers have not overlooked what is probably the most important feature of a book of this kind, a complete and copious index.

*Handbook for Machine Designers and Draftsmen.* By Frederick A. Halsey, B.M.E., editor emeritus of the American Machinist. 483 pages. 8½ in. by 11 in. Bound in cloth. Illustrated. Published by the McGraw-Hill Book Company, Inc., 239 West 39th street, New York. Price \$5.

Mr. Halsey states in the preface that the manner in which contributions to technical journals of permanent value and usefulness form a procession to the limbo of forgotten things and benefit none but those under whose eyes they happen to fall at the date of publication, has always been a source of extreme regret to him. In this volume he has made an effort to rescue

from the oblivion of the out of print such contributions as are of direct use in the design of machinery. The search for material has not been limited to periodicals, but has extended to the transactions of many engineering societies wherein information is nearly as effectively buried as in the back numbers of periodicals and, furthermore, he has freely called on the knowledge of many of his friends. It needs but a casual examination of this book to show the accuracy of the author's contentions. While most of it has been published before, it is not until it is collected and classified, as is done here, that the reader is fully impressed with the value of the information. It is, of course, impossible to give here even a fairly clear idea of the material that is included, but, when it is stated that there are 40 different subjects treated, each as a chapter covering from 7 to 38 large pages, it will be appreciated that the scope is broad. These chapters are on subjects of the greatest importance to machine designers and cover such matters as springs, gears, transmissions, clutches, cams, bearings, bolts, nuts, and screws, pipes and pipe joints, balancing, materials, compressed air, mechanics, etc., in addition to a large number of mathematical tables, many of which are not given in the ordinary handbook.

*Principles of Industrial Organization.* By Dexter S. Kimball, professor of machine design and construction, Sibley College, Cornell University. 268 pages. 6 in. by 9 in. Bound in cloth. Illustrated. Published by McGraw-Hill Book Company, Inc., 239 West 39th street, New York. Price \$2.50.

As Professor Kimball truly points out, industry is the business of the civilized world and the greater part of our problem, national, state and home, centers around the great industrial question. Furthermore, it is being looked on as the great basic feature of our civilization on which we must rest our entire well being. With this new evaluation of industry has come new and higher ideals regarding service to humanity. It is for these reasons that the ideas embodied in the so-called scientific management are coming in for such close scrutiny. Changes of similar character and as far reaching in their effects have been made in our industrial methods in times past with little or no comment from any quarter. But today, changes of this character cannot be made as formerly on the basis or plea of increased production alone. The specter of distribution of profits, the bugbear of our industrial system stands constantly in the background, and the question that it ever raises—What will be the effect of these changes on humanity?—can no longer be ignored. It is not the purpose of this book to exploit any form of industrial management or any specific remedy for industrial evil, but it is an endeavor to set before young men entering the industrial field the salient facts regarding the most important movements with which they are sure to be brought in contact and to explain the origin and growth of the important features of industrial organization. To the engineer who is continually being brought more and more in contact with economic problems, these are matters of particular importance. While it is for the needs of young engineers primarily that the book has been written, being based on a course of lectures given by the writer to the senior class at Sibley College of Mechanical Engineering, Cornell University, the practicing engineer or manager who wishes to know something of the fundamental principles of organization, without regard to some specific system of management, will find it also of interest. It has been the writer's endeavor to deal as far as possible with general principles and no effort has been made to illustrate the many kinds of cards and forms used in industrial management. The book contains fourteen chapters, the first four being more or less historical in their nature, and the fifth covering modern industrial tendencies. In other chapters are treated separately the forms of industrial ownership, principles of organization, planning departments, principles of cost keeping, depreciation of wasting assets, compensation of labor, purchasing, storing and inspection of materials, location, arrangement and construction of industrial plants, and the theories of management.

## COMMUNICATIONS

### JIG FOR GRINDING IN ROTARY VALVES ON E-T EQUIPMENT

CORBIN, Ky., January 10, 1914.

TO THE EDITOR:

I have read with interest Mr. Bentley's article on jigs for grinding in rotary valves on page 42 of the January number. In my experience with this class of work the absence of the valve guide has proved a decided advantage over the older construction where a guide stem is used with the rotary valve, inasmuch as the valve can be moved over the valve seat with a criss-cross motion. I would suggest that the high surface be cut down with a scraper and the criss-cross motion tried. Where the guide is used the valve travels in the same channel all the time and is a source of trouble to repair men unless the surfaces are machine ground or spotted down very closely with a scraper.

J. A. JESSON,

Air Brake Foreman, Louisville & Nashville.

[Mr. Bentley's reply to this criticism is given below.—EDITOR.]

TO THE EDITOR:

As a result of experimenting with a view to saving time on this class of work, I have dropped away from the process of working these valves with face plate and scraper. My method has given a great deal of satisfaction and is, I believe, fully as thorough as the older method. The rotary and valve are faced on a lathe, where the lateral is eliminated as far as possible. With a wooden block on which a strip of fine emery cloth is tacked, the surface is cleared of all tool effects and the valve or seat relieved, to some extent, of the effect of the lighter cut which is always present near the outer portion of circular facing work. This affords a nearly perfect surface and necessitates the use of only a fine grade of grinding compound to bring it to a good seat. With the finer grade compound I have experienced no trouble in the disagreeable occurrence of circular scratching or ridging, and the result of using the guide ring is to assist the bringing of the heavier bearing to the center of the rotary and seat.

F. W. BENTLEY, JR.

### WIRING FOR ELECTRIC HEADLIGHTS

SACRAMENTO, Cal., January 24, 1914.

TO THE EDITOR:

The wiring shown in Fig. 1 of the article on the Installation and Maintenance of Electric Headlight Equipment, by V. T. Kropidowski, which appeared in the July, 1913, issue of the Railway Age Gazette, Mechanical Edition, will not meet the requirements when it is desired to cut out both the arc and the pilot lamp, as in the case of a train in the clear on a siding

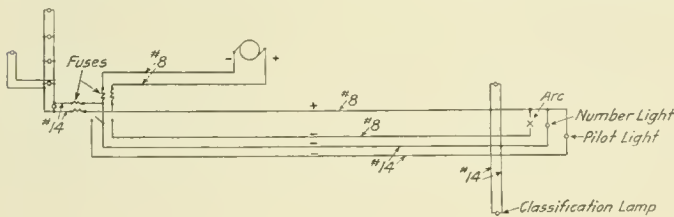

Western Pacific Headlight Wiring

waiting for another train to pass. The reason is that as soon as the switch in the cab is removed from clip 3, the arc lamp carbon will drop and complete the circuit so that the pilot lamp will light immediately without the switch being thrown into clip 1. In order to be able to cut out both the arc and the pilot lamp, it is necessary to run a fourth wire from the pilot lamp to the switch, as shown by the accompanying diagram which is taken from the Western Pacific standard wiring drawing. As the requirement is practically universal that the headlight be extinguished or completely covered when a train is in the clear

on a siding, I would suggest that a wiring diagram that will meet the requirements be shown.

W. E. JOHNSTON,

Chief Draftsman, Western Pacific.

[Mr. Kropidowski's reply to the foregoing letter is given below.—EDITOR.]

WINONA, Minn., February 12, 1914.

TO THE EDITOR:

Concerning Mr. Johnston's criticism of the mode of wiring; when the arc lamp is shut off and the carbons come together there will be a path established to the circuit of the incandescent pilot lamp. It was taken for granted that this would be plain to electrical men and for that reason attention was not drawn to it at the time. Of course, it is understood that this does not provide a solid and permanent contact and the lamp will flicker, owing to the poor contact and the jarring of the locomotive. As to enginemen not being able to extinguish the headlight entirely when waiting on a siding, before the electric headlight was in use they had to get off, climb on the pilot beam and cover the face of the lamp with a cover provided for the purpose. With the electric equipment the fireman can step out on the running board, raise one of the generator brushes and place a small chip of wood between the brush and the commutator, which is certainly easier than the old way. I believe that the simplifying of the wiring, which is one of the biggest factors in reducing troubles and failures, and is also effective in trying to locate trouble in the system, more than offsets the little inconvenience of one of the enginemen's having to step out on the running board when in a siding to meet a train.

V. T. KROPIDOWSKI.

### COLLEGE MEN AND THE RAILROADS

R——, Pa., January 3, 1914.

TO THE EDITOR:

I have read with mingled pleasure and regret, the several articles appearing in recent issues of your publication, under the heading, "College Men and the Railroads," and, as I believe that much of the discussion and some of the conclusions are not justified, and that, in the main, injustice is done the unfortunate "college man," I feel in duty bound to assist in the removal of prejudice, against him, which prejudice, however, I am confident, will have disappeared entirely within the next score of years.

What is a "college man"? Is he constructed of a different clay, or was his life up to the age of 18 years materially different from that of others? At college he associated with several hundred young men of approximately his own age, during a portion of each of four consecutive years. During this time he certainly got some good bumps from his fellows. He must have done a large amount of work requiring mental effort, thus developing his mental capacity, either memory or reasoning powers or both, and in some courses he must have had a varied and valuable, though brief, shop and mechanical laboratory experience in connection with the class room work. Can he then leave college so utterly worthless as some men who have not attended college would have every one believe?

I think that the average college trained man is handicapped by his experience at college, not because he thinks he has learned it all or considers himself superior, but quite on the contrary, because he has been thoroughly impressed with the fact that all he knows or ever can know, is but an infinitesimal part of what there is to learn.

His brother who ran a nut tapping machine for a year, turned up bolts another year, ran a planer or shaper, possibly helped put up cab fittings, a steam chest or two, and if especially favored, helped lay out a few sets of shoes and wedges during the final two years of his shop apprenticeship, has, because of his narrow horizon, frequently developed a most thoroughly exaggerated ego; he has confidence in himself to the ends of his small earth and momentarily is of more value than the col-



lege man. The swelled heads unfortunately are not all on the shoulders of the men from the universities.

I believe the causes for failure of college men, not applicable to non-college men, are, in order of their importance: (1) The narrow, distorted, egotistical old-time managers who are fast disappearing. (2) The lack of force on the part of the college man, due to his thorough knowledge that he knows so little. (3) The "molly-coddling" some young men receive before and while at college.

Let us stop making a distinction between so-called college and non-college men. That an individual has undergone the training required in higher educational institutions does not insure that he is better equipped to fight life's battles in general or in particular than is his brother who may not have had such advantages, but who may have inherited a brain of greater capacity, or who has accomplished greater development by study outside school walls.

Special apprentice courses should be open to non-college, as well as college, men. I prefer an educated jack ass to an uneducated one and believe that the "wonder" who never saw the inside of a school house would have been a greater wonder if he had.

W.

CHICAGO, Ill., October 21, 1913.

TO THE EDITOR:

The article appearing in the October issue, signed J. I. W., puts the cart before the horse. Instead of "why don't the railroads hold the college man?" the question should be "why doesn't the college man stay with the railroads?"

The best of the college men who enter the railroad service do stay and those who enter the service and leave in the earlier stage of the fight, leave for several reasons:

First, many of the special apprentices have contracted debts in order to get through college and even after they have begun their apprenticeships, often quit and go in search of work which will be more remunerative, at least for the time being, in order that they may make sufficient money to liquidate their bills.

Second, the average college man is unwilling to start at the bottom and work up. He thinks that immediately after serving his apprenticeship an official position should be given him. The railroads are not in the habit these days of entrusting the management of their shops or roundhouses to men without considerable practical experience, together with a distinct showing for leadership or evidence of executive ability. These qualifications are not always possessed by college graduates.

Third, the college graduates are not satisfied with what they deem the low rate paid by railroads for special apprentices, thought, in fact, it is what the railroads think special apprentices are worth. Very few railroads are able or willing to pay a man more than he is worth for any length of time. The complaint of the college man that the railroads do not give the special apprentice a chance, is a cry of the weak and underserving. We generally find out that where an ordinary journeyman apprentice makes a complaint that he is not being given a show, he is not entitled to much of a show, that there is something in his make-up which tends to prevent the shop authorities from especially exerting themselves in his behalf. If he is a bright, active, aggressive apprentice, he does not make this cry. He goes ahead and attends to his work and the opportunities will come to him. The great trouble is with the colleges, as none of our universities and colleges ever take the pains to study the student's make-up, or ever go to the trouble of ascertaining his fitness for the course he is studying. Often he goes into it because somebody, a friend, or sometimes a relative, has suggested it to him. Consequently we have hundreds of graduates from our technical schools in mechanical engineering, who really have no talent or love for engineering work. These men will never be satisfied, regardless of the work or position given them. The majority of our schools spend too much energy getting students, and none decrease their enrollment by advising young men to discontinue the course they

have selected. I am not ready to believe that all the other special apprentices who go into commercial fields make such a howling success. It is true that the commercial field requires men who are technically educated, to a greater extent than do railroads. With the exception of the mechanical engineer, engineer of tests and chemist, there is no absolute necessity for the other officials in the mechanical department to be college men. In fact, one of the largest and most prosperous western roads has not a single master mechanic who has had a college education.

The college man is usually unwilling to begin at the bottom, although he is perfectly willing to do any special work and glad to work in the test department, but the special apprentice who serves most of his time in the drafting room and with the engineer of tests, will be up against it if placed in charge of a large roundhouse. At the same time he is unwilling to go into a roundhouse and work as a journeyman and familiarize himself with the needs and requirements of such a place. In fact, the writer knows of an instance of a special apprentice who was graduated from one of the large eastern colleges, who, in conversation with another special apprentice that had completed his apprenticeship and was climbing up the ladder, remarked that he only had two months before his apprenticeship would be completed and would be awfully glad of the time when he could get out of wearing overalls and doing dirty work. Now this young man had an idea that as soon as he completed his apprenticeship a master mechanicship awaited him. The road on which this young man was serving his time was giving him every opportunity to acquire the practical work and to show what stuff was in him.

Very few foremanships, these days, are made through pull, and even if made that way, the man must have some merit in order to hold the job. I am sure wherever a special apprentice will show that he has merit he will have just as good chances of promotion from the ranks as the ordinary journeyman apprentice. The writer does not know of a single instance where a man has been promoted from the ranks to a master mechanic's position at one jump and succeeded. Gang, back shop and roundhouse foremen are absolutely necessary training for the master mechanicship, and it is these minor positions which the special apprentices object to filling.

It is unnatural and unreasonable to ask the railroads to provide separate machines and special instructors for the few special apprentices. The expense would be prohibitive and the results fruitless. Such a proposition is in keeping with the average college graduate. He expects things to be done solely for his own good, and thinks that he is better than others and should receive special treatment. Such a scheme would produce a most undesirable caste. To be a successful foreman or official in any department the man must be a mixer, he must know the men in the ranks, their methods, their ways, their shop language. He must know how to do the work himself. This is the reason why the machinist who served his regular apprenticeship generally makes the best foreman. The college man under similar conditions with the advantages of a technical education, and his reasoning faculties more largely developed, should on paper make the best official, but we do not find this the case in actual practice. There are no men or set of men who need a pull more than the college man and there is no one so pitifully helpless as the college man in a modern shop. There is not a single school in the country that can graduate a master mechanic, fit him for the job, ready to go on duty the day he receives his diploma. West Point and Annapolis are the two schools in this country which graduate the officer. But look what they must pass through during the four years. No man requiring the attention of a surgeon will trust his case in the hands of an M. D. who graduated one hour ago. Nor will he entrust his legal affairs to one just admitted to the bar. These young M. D.'s and B. L.'s must serve an apprenticeship in a hospital or law office of older heads. We are glad to get college men, but we are unwilling to nurse them any more than the sixteen-year-old boy with only a sixth grade common school education.

AN OLD COLLEGE MAN.

# LEHIGH VALLEY PACIFIC TYPE LOCOMOTIVE

## Anthracite Burning Passenger Engines for Heavy Grade Work; Valve Setting Given Close Study

The Lehigh Valley recently designed a heavy Pacific type superheater locomotive and has placed six of them in passenger service on the division between Easton, Pa., and Sayre, Pa., a distance of 194 miles. The maximum grade on this division is between Mauch Chunk and Wilkes-Barre, Pa., over the Wilkes-Barre mountain. The grade between Mauch Chunk and Glen Summit (the top of the mountain) is 33.7 miles long, and has a maximum rise of 67 ft. to the mile, westbound. The grade between Wilkes-Barre and Glen Summit

der to obtain the maximum tractive effort at high speeds per pound total weight of locomotive. On account of the low factor of adhesion it was necessary to design the valve gear to obtain a rotative effort as nearly constant as possible, thereby keeping the factor of adhesion very close to the theoretical. How well this has been accomplished is illustrated by the torsional diagram combining both cylinders when developing 2,100 indicated horsepower with a cut-off of 66 per cent at 148 revolutions per minute. It will be seen

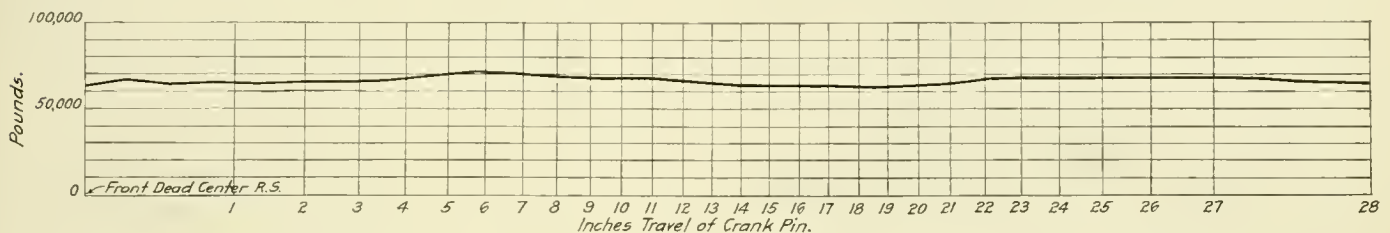

Turning Effort at the Crank Pin for a Full Stroke; The Effect of Both Cylinders is Considered

is 19.6 miles long with a maximum of 95.7 ft. to the mile eastbound. A profile of this section is shown in one of the illustrations.

These locomotives were designed to haul, unassisted, passenger trains weighing 550 tons westbound, and trains of 360 tons eastbound, over this division. Heretofore it has been necessary to double head trains of these weights over this portion of the road, using a Pacific type locomotive having a total weight of 241,300 lb. and a tractive effort of 31,600 lb.,

that the turning effort is practically uniform for the full revolution.

Piston valves 14 in. in diameter are driven by Walschaert valve gear. The valves have a travel of 6 in., a steam lap of  $1\frac{1}{4}$  in., an exhaust clearance of  $\frac{1}{8}$  in. and a lead of  $\frac{5}{16}$  in. The large amount of lap is apparently responsible for the even turning movement.

A screw reverse gear is applied, and on account of the extreme width of the firebox it will be noted that it was neces-

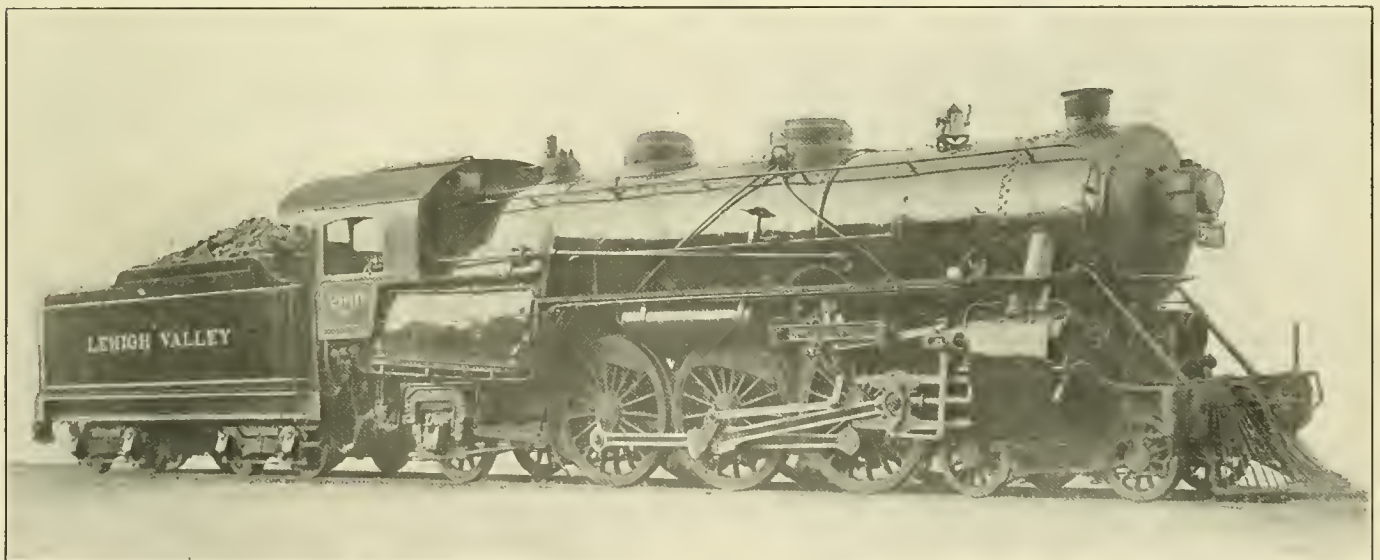

Passenger Locomotive for Service on Heavy Grades on the Lehigh Valley

and a ten-wheel helping locomotive having a total weight of 199,500 lb. and a tractive effort of 31,400 lb.

The new Pacific type has a total weight of 262,000 lb. and a tractive effort of 41,500 lb., the factor of adhesion being 3.89. The total evaporative heating surface is 3,744 sq. ft. and, making the usual allowance for the superheater, the total equivalent heating surface is 4,962 sq. ft. This gives 8.35 lb. theoretical tractive effort per pound of equivalent heating surface.

Special attention was given to the details of design, in or-

der to insert a universal joint in the reach rod just ahead of the bearing at the front end of the firebox.

One of the interesting features of the valve gear is the valve stem crosshead, which is of the self-centering type and is so constructed that the pin is provided with a nut. This is unusual in this type of crosshead, and permits the pin to be removed without taking down the crosshead. This detail is shown in one of the illustrations.

The side rods are of the semi-I section having a flange  $1\frac{3}{4}$  in. in width and  $1\frac{3}{8}$  in. in depth at the center of the rod,



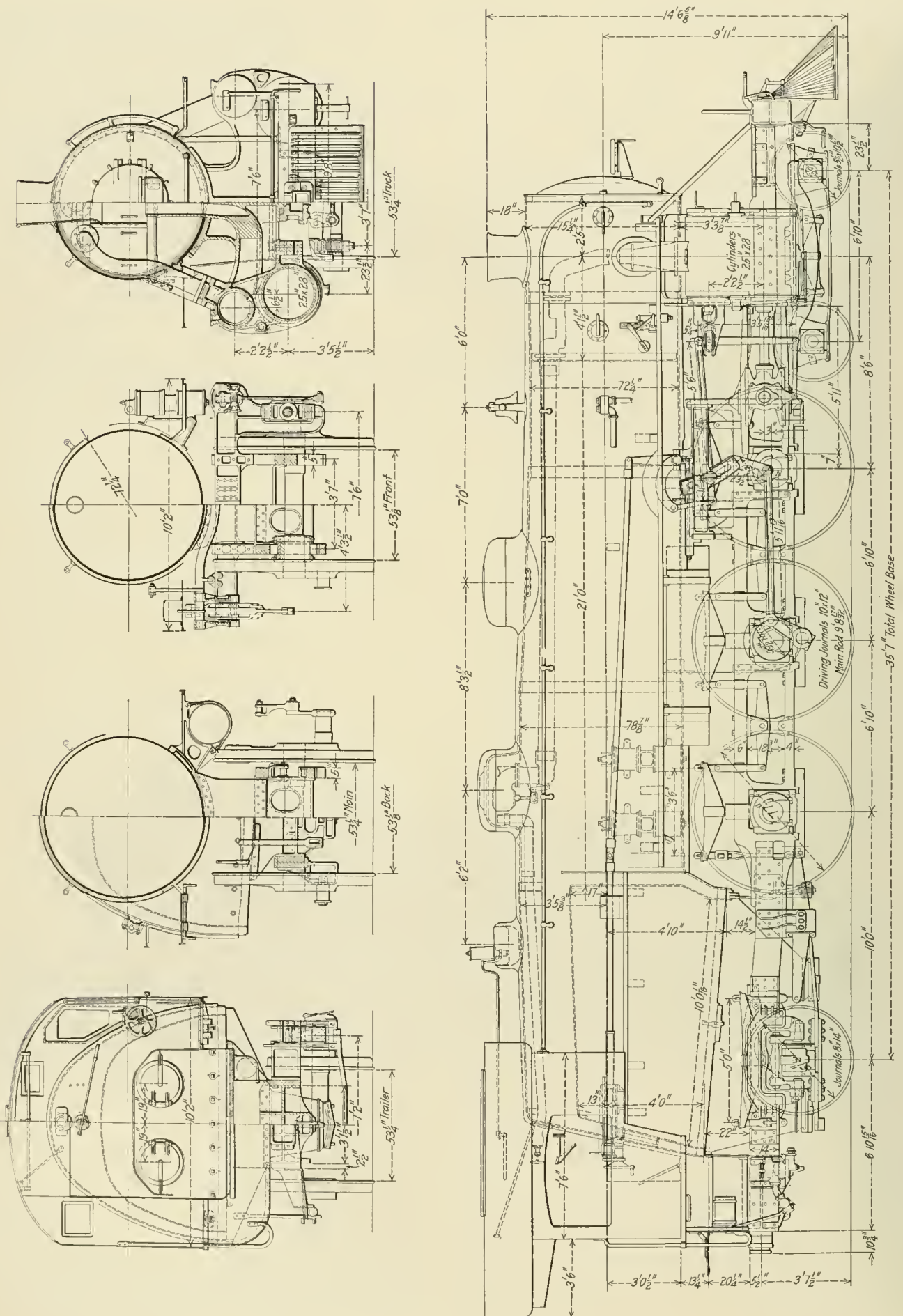

Pacific Type Locomotive Designed and Built by the Lehigh Valley

while the web is 1/2 in. thick and 3/4 in. deep for the back connection and the same thickness and a varying depth for the front rod. The back rod is of uniform section for its length while the rod connecting the main with the front driver is 8 in. in total depth at the beginning of the flanged section

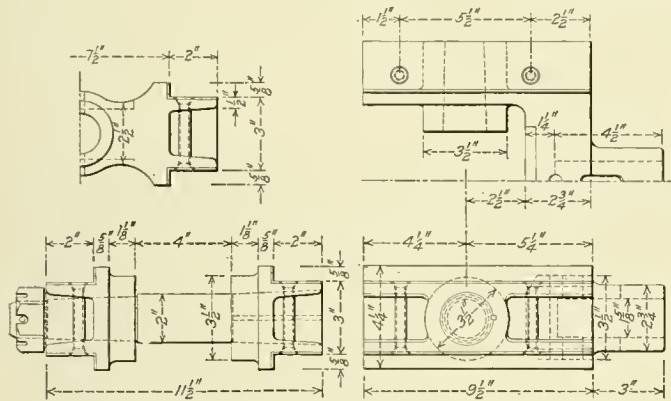

Valve Stem Crosshead of the Lehigh Valley 4-6-2 Type Locomotive

and 6 in. at the front end. The rods are 4 1/2 in. in width at the pin.

The tender cistern construction was fully illustrated on page 72 of the February issue of this journal. It follows a new departure which requires the top and bottom sheets of the cistern to be flanged and riveted to the side and end sheets, thus eliminating the angle iron connection and all rivet holes through the bottom of the cistern. This con-

hem, Pa., and Wilkes-Barre, Pa. This is an all steel parlor car train consisting of eight cars, weighing 603 tons behind the tender, exclusive of baggage and passengers.

Following is the general data and proportions of these locomotives:

General Data

Gage	4 ft. 8 1/2 in.
Service	Passenger
Fuel	Anthracite
Tractive effort	41,597 lb.
Weight in working order	262,160 lb.
Weight on drivers	161,940 lb.
Weight on leading truck	49,420 lb.
Weight on trailing truck	50,800 lb.
Weight of engine and tender in working order	404,860 lb.
Wheel base, driving	13 ft. 8 in.
Wheel base, engine and tender	76 ft. 4 3/4 in.

Ratios.

Weight on drivers ÷ tractive effort	3.89
Total weight ÷ tractive effort	6.30
Tractive effort × diam. drivers ÷ equivalent heating surface*	642.00
Total equivalent heating surface ÷ grate area	56.80
Firebox heating surface ÷ total saturated heating surface, per cent.	6.00
Weight on drivers ÷ total equivalent heating surface	32.60
Total weight ÷ total equivalent heating surface*	52.80
Volume both cylinders, cu. ft.	15.90
Total equivalent heating surface* ÷ vol. cylinders	310.00
Grate area ÷ vol. cylinders	5.50

Cylinders.

Kind	Simple
Diameter and stroke	25 in. x 28 in.

Valves.

Kind	Piston
Diameter	14 in.
Greatest travel	6 in.
Steam lap	1 3/4 in.
Exhaust clearance	3/8 in.
Lead	5/16 in. constant

Wheels.

Driving, diameter over tires	77 in.
Driving journals, main	10 in. x 18 in.
Driving journals, others	10 in. x 12 in.

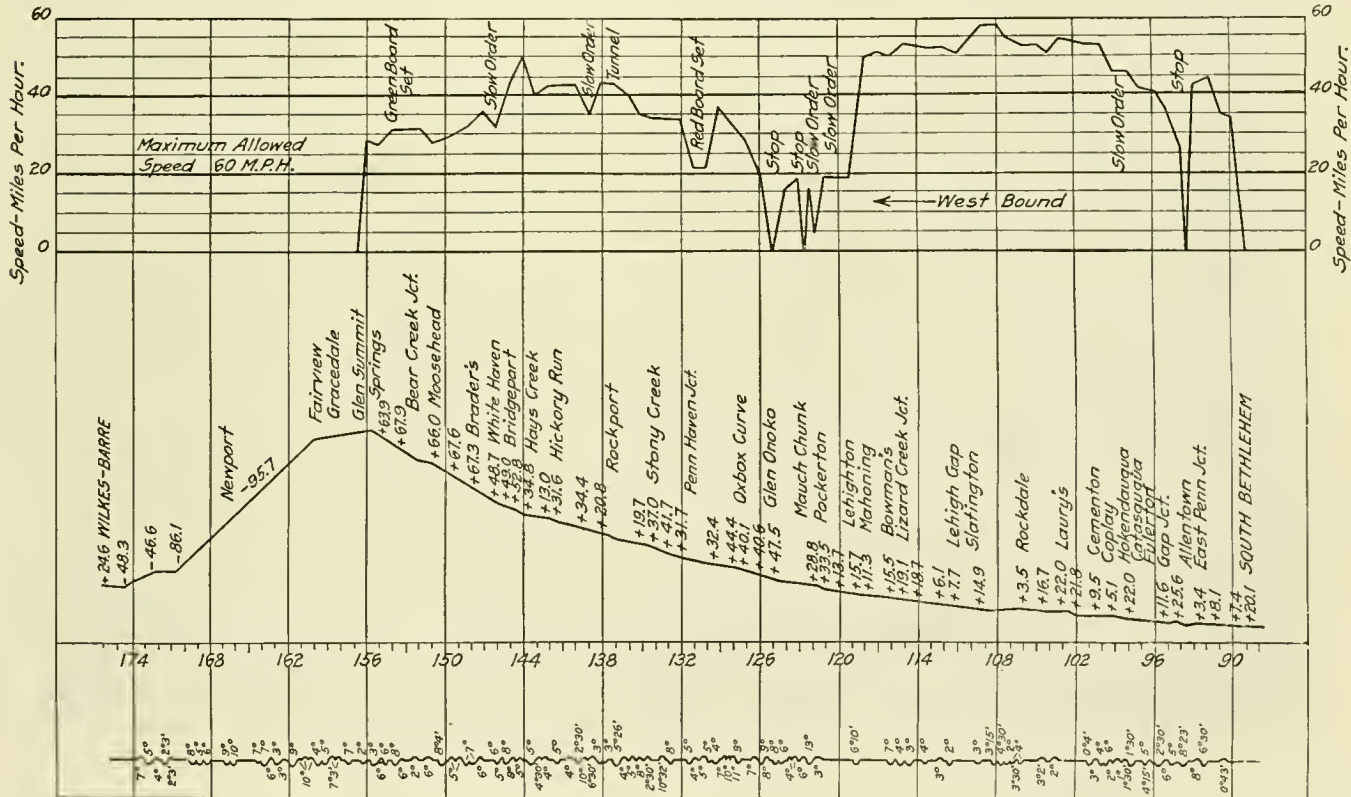

Profile of Lehigh Valley from South Bethlehem to Wilkes-Barre; The Upper Curve is a Speed Chart of the Eight Car Train (603 tons) Drawn by One of the New Pacific Type Locomotives

struction not only reduces the first cost, but also gives a lower cost of maintenance.

That these locomotives are doing all that was expected of them is illustrated by the speed chart performance while hauling the Black Diamond Express between South Bethle-

Engine truck wheels, diameter	36 in.
Engine truck journals	5 1/2 in. x 10 1/2 in.
Trailing truck wheels, diameter	51 in.
Trailing truck journals	8 in. x 14 in.

Boiler.

Style	Wooten
Steam pressure	215 lb.



Outside diameter of first ring.....	72¼ in.
Firebox, length and width.....	126½ x 104½ in.
Firebox plates, thickness.....	¾ in.
Firebox, water space.....	F., 4½ in.; S. & B., ¾ in.
Tubes, number and outside diameter.....	234—2 in.
Flues, number and outside diameter.....	32—5¾ in.
Tubes, length.....	21 ft.
Heating surface, tubes.....	3,519 sq. ft.
Heating surface, firebox.....	225 sq. ft.
Heating surface, total, evaporating.....	3,744 sq. ft.
Superheater heating surface.....	812 sq. ft.
Total equivalent heating surface.....	4,962 sq. ft.
Grate area.....	87 sq. ft.
Smoke stack height above rail.....	14 ft. 6½ in.

Tender.

Frame.....	13 in. channel
Wheels, diameter.....	36 in.
Journals, diameter and length.....	5½ in. x 10 in.
Water capacity.....	7,000 gallons.
Coal capacity.....	12 tons

\* Equivalent heating surface = evaporative heating surface + 1½ times superheater heating surface.

on the latter variety of paper compared with that of the same chart on ordinary coordinate paper. To make a fair comparison, assume a 10 in. square of ordinary paper, whose sides are divided into 100 equal parts. Each division equals .1 in. Assume that it is possible to read within .01 in. or .1 of a division. Then the accuracy of using the chart, say at 75, is with less than  $.1 \div 75 = .133$  per cent. of error. At 10 the error is less than  $.1 \div 10 = 1.0$  per cent. In other words, the error increases as we approach the origin.

Consider the corresponding logarithmic paper. At 75, .01 in. equals .357 of a division. The error is less than  $.357 \div 75 = .476$  per cent. At 10, .01 in. equals .0476 of a division. The error is less than  $.0476 \div 10 = .476$  per cent. In other words, there is always a uniform percentage of accuracy for all parts of a chart on this kind of paper. This is no small advantage, as it makes it possible to condense charts and still obtain the required accuracy.

One of the most useful purposes of logarithmic paper is the representation of formulas, which are curves on ordinary coordinate paper but straight lines on logarithmic paper. Thus, all equilateral hyperbolas in the form  $xy = c$  are straight lines on this paper. Also steam engine and gas engine curves in the form  $PV^n = C$  are all straight lines. The application of logarithmic paper in the analysis of the cylinder performance of reciprocating engines is dealt with by J. Paul Clayton in bulletin No. 58 of the Engineering Experiment Station of the University

### ADVANTAGES OF LOGARITHMIC COORDINATE PAPER

BY TOWSON PRICE

Although logarithmic coordinate paper is of comparatively recent origin and has a comparatively small field of use, there are several important advantages which it has over ordinary coordinate paper, that are well worth noting.

There are two grades of logarithmic paper, as sold by Keuffel &



Esser, one on which the divisions of the 10 in. square are from 1 to 10, corresponding to the lower scale divisions of an ordinary 10 in. slide rule. The other is on translucent paper, suitable for blue printing, and is divided into four 5 in. squares, the divisions corresponding to those of the upper scale of an ordinary 10 in. slide rule.

Let us consider the relative accuracy of making use of a chart

of Illinois. This bulletin shows how to transfer indicator diagrams to logarithmic paper, determine cylinder clearance and leakage, and find the value of  $n$  in  $PV^n = C$ . These are only a few of the uses of this paper. All expressions of the form  $y = x^2$ ,  $cx = y^n$ , etc., are straight lines on logarithmic paper.

L. R. Pomeroy has made frequent use of logarithmic paper in constructing many of the charts which have appeared in the



Railway Age Gazette, Mechanical Edition, as far example on page 436, of the August, 1913, issue.

Suppose that we wish to prepare a chart for quickly finding the approximate horsepower a locomotive is developing for the known draw bar pulls and speeds on a dynamometer test.

Let HP = horsepower, F = tractive effort or draw bar pull in pounds, and V = speed in miles per hour. Then  $HP = FV \div 375$ . A series of horsepower lines on ordinary rectangular cross section paper would be a series of hyperbolas, as this

To make this chart it is only necessary with logarithmic paper to plot two points for each of the equations  $Z = \frac{1}{2}Y^2$  and  $U = \frac{1}{3}Y^3$ . Thus, draw a straight line through the points .2, .02 and .4, .08 for the first and one through the points .3, .009 and 6, .072 for the second. This chart could be used as it stands, or it could be used to prepare a nomogram similar to that on page 381 of the August 29, 1913, issue of the Railway Age Gazette. If a chart to represent these equations were made on ordinary cross section paper, a series of points would have to be found

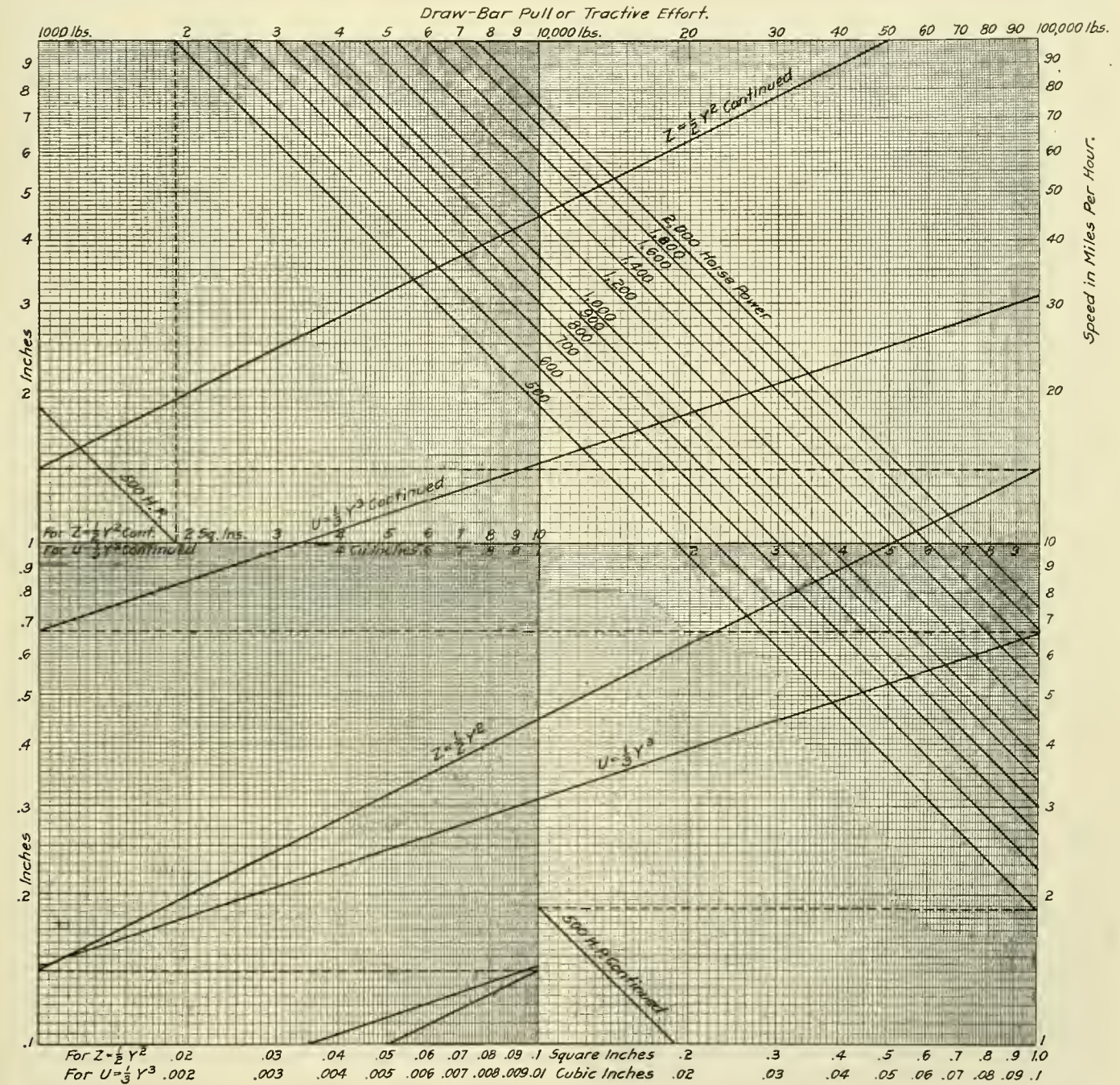

Chart Illustrating the Uses of Logarithmic Paper

equation is of the form  $xy = c$ ,  $x = F$ ,  $y = V$ , and  $c = 375HP$ . It would be a laborious task to construct a large number of these; also they would not be very accurate unless a considerable number of points were plotted for each. On logarithmic paper, on the contrary, these horsepower lines are all straight and parallel to each other, making angles of 45 deg. with the axes. This makes it necessary to find only one point for each line to make the chart as shown.

for each of the equations and curves drawn through these points, as shown.

Mr. Pomeroy's tractive effort chart, in the Railway Age Gazette, Mechanical Edition, August, 1913, page 436, is a combination of graphical division and multiplication, for which purpose logarithmic paper is ideal. Another advantage of this paper is the ease with which the lines may be continued, as indicated on the chart.



## REINFORCED CONCRETE COALING STATION

Reinforced concrete has a number of advantages as a material for locomotive coaling stations. This is especially true where the mechanical type of station is selected and the ground area occupied is comparatively small. A large number of recent stations of this kind, that have been erected at various points throughout the country, have been built of this material and so far have seemed to develop very few disadvantages.

Among the recent reinforced concrete coaling stations which can be taken as a good example of the latest design and construction, is one erected for the Indiana Harbor Belt Railway at Blue Island, Ill. This station, while not as large as some others, is about the average size for an ordinary terminal where two coaling tracks are sufficient.

It has a storage capacity of 500 tons in the pocket and an elevating capacity of 75 tons an hour. The station is entirely automatic as regards the elevation of the coal to the pocket and is electrically driven. As will be seen in the illustrations, the coal is received on a center track passing beneath the pocket and is discharged to a hopper under the track. The hopper is 30 ft. in length and is designed with a slope of 40 deg. It leads



Reinforced Concrete Coaling Station at Blue Island, Ill.

to a measuring feeder and is entirely self-clearing. The feeder is automatic in its operation and is actuated by the ascent and descent of the Holmen type elevating bucket which passes up a shaft through the pocket.

The pocket is supported on eight reinforced concrete columns, the center supports being 18 in. by 24 in. in section and the end columns 14 in. by 24 in. in section. The pocket is 45 ft. 8 in.

high over all and is 33 ft. in length by 28 ft. wide. All the concrete used is mixed in the proportion of 1-2-4, and the reinforcing rods are of the corrugated section. The bucket tower and the canopy over the pocket are of structural steel and the operator's hoist house on the ground level is of the same material. The outside covering of these structures is of rust-resisting galvanized American ingot iron.

The single elevating bucket is arranged with a 6-in. roller on

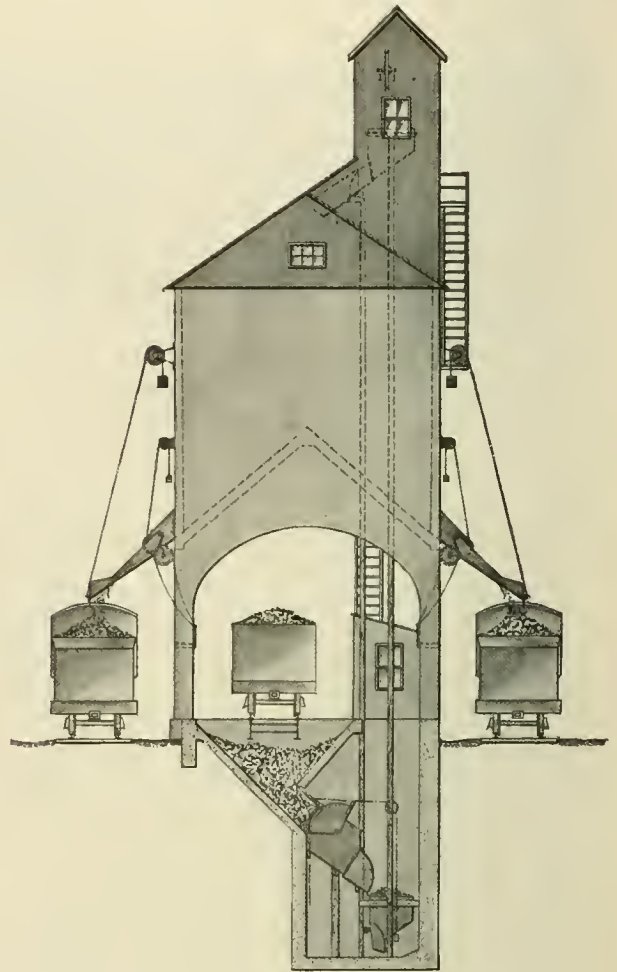

Section Showing Arrangement and Location of Hoisting Apparatus

the apron, which travels on a continuous steel guide from the bottom of the pit to the bucket discharge point. This positively assures the closing of the bucket at all times in its travel, except when discharging coal at the top. It is carried by a  $\frac{7}{8}$ -in. special hoisting cable which passes over a 40-in. diameter sheave at the top and continues downward around the drum of the electric hoist and then to the counterweight which balances the load. The hoist is equipped with Falk patented herringbone steel gears and is direct connected to a 22 horse power, crane type, electric motor. This motor is equipped with a solenoid brake mounted on one end of the motor shaft to prevent the dropping of the bucket in case the current is cut off. An automatic bucket hoist control with treadle switches permits the automatic operation of the elevating process without any attention from the operator. This station is equipped with four sets of improved rack and pinion undercut gates which are manually operated and do not depend on counterweights for closing. The flow of coal is cut off from underneath and the aprons are made of  $\frac{3}{16}$  in. and  $\frac{1}{4}$  in. steel plate, properly reinforced with angles and equipped with hoods to deflect the coal directly to the tender.

This station was designed and erected by the Roberts & Schaefer Co., Chicago, Ill.

# STRENGTH OF LOCOMOTIVE BOILERS

## Discussion of the Features to Be Considered in Filling Out Reports to the Federal Board

BY WM. N. ALLMAN

The strength of locomotive boilers has been given much study, more particularly during the past few years, largely because of the act of Congress, approved February 11, 1911, and the formation of different state boiler commissions.

The filling in of the specification cards has meant considerable labor, especially where a road has many different classes of locomotives. In such cases, the various boilers must be stripped and measurements taken as a preliminary to making the various calculations.

The writer has prepared a number of simple formulas based on well established and authorized rules, which can be used in determining the different stresses, as called for on the forms required by the Interstate Commerce Commission and the various state boiler commissions. These forms are identical in many respects.

Boiler form No. 4, for the Interstate Commerce Commission, requires something more than merely filling out existing records, covering such items as the different appurtenances, dimensions and the tensile strength of the shell plates. Careful

the rivet hole and the edge of the plate and the shearing of the rivet; crushing of the rivet or plate in front of the rivet and the shearing of one rivet; rivet shearing out of the plate in front of it and the shearing of one rivet.

The two by which the joints generally fail are the shearing of the rivets or the tearing of the plate along the line of rivets. The others generally give a higher efficiency.

The shearing value of rivets in single and double shear, as specified in the rules and instructions for the inspection and testing of locomotive boilers and their appurtenances, issued by the Interstate Commerce Commission, specifies a value in double shear to be equal to double that of single shear, these values being as follows:

Iron rivets in single shear.....	38,000 lb.
Iron rivets in double shear.....	76,000 lb.
Steel rivets in single shear.....	44,000 lb.
Steel rivets in double shear.....	88,000 lb.

The table given below serves to illustrate the value of the shearing strength of rivets as used by several large builders of boilers, and also as given by different authorities.

Resistance to Shearing; lb. per sq. in.				Relative value double to single shear		Value based on driven or initial size of rivets	Authority.
Single Shear		Double Shear		Iron	Steel		
Iron	Steel	Iron	Steel	Iron	Steel		
38,000	.....	76,000	.....	2	2	Driven	Railway Master Mechanics' Association.
38,000	44,000	76,000	88,000	2	2	.....	Proposed Government Rules. Adopted June 2, 1911.
41,000	47,000	82,000	94,000	2	2	Driven	W. C. Unwin.
.....	.....	.....	.....	2	2	.....	Thurston, R. H. "Manual of Steam Boilers."
50,000	.....	.....	.....	2	2	.....	Weisbach, Julius. "Theoretical Mechanics."
.....	.....	.....	.....	.....	2	.....	Cambria Steel Company.
.....	50,000	.....	.....	.....	2	.....	Carnegie Steel Company.
.....	Note	.....	.....	.....	2	.....	Bureau Veritas (French).
40,000	49,000	78,000	84,000	1.95	1.71	Driven	Master Steam Boiler Makers' Association, 1905.
.....	.....	.....	.....	.....	2	.....	Engineering Department, B. & O. R. R.
.....	Note	.....	.....	.....	*1.75	.....	British Lloyds.
40,000	50,000	.....	.....	.....	.....	.....	Pencoyd Iron Works.
40,000	.....	.....	.....	.....	.....	.....	National Tube Company.
40,000	49,000	74,000	84,000	1.85	1.85	Driven	The Baldwin Locomotive Works.
38,000	42,000	70,000	78,000	1.84	1.86	Driven	Board of Boiler Rules of Massachusetts.
38,000	42,000	70,000	78,000	1.84	1.86	Driven	Hartford Steam Boiler Inspection and Insurance Company.
.....	48,000	.....	72,000	.....	1.75	Driven	Maryland Steel Company.
.....	Not specified—Rivets proportioned to thickness of plates.			.....	.....	.....	Board of Supervising Inspectors, U. S.
.....	46,000	.....	80,500	.....	1.75	.....	British Board of Trade.
.....	Note	.....	.....	.....	.....	Driven	German Lloyds.
40,000	.....	75,300	.....	1.85	.....	Driven	Philadelphia Rules.
.....	.....	.....	.....	1.75	1.75	Driven	American Locomotive Company.
.....	.....	.....	.....	1.75	1.75	Initial	Public Service Commission, New York.
40,700	.....	75,300	.....	1.85	.....	.....	Shock (Chief Engineer Naval Academy).
.....	50,000	.....	.....	.....	.....	.....	Kennedy, Alex. B. W. (Test made for British Inst. of Mech. Eng.)

NOTE.—85 per cent. of the tensile strength of the plate.

\* Where experiments have been made.

† 43,000 lb. to 68,000 lb.

calculations must be made to determine the strength of the different parts. The stresses required on this form are: Calculated efficiency of the weakest longitudinal seam; maximum stress in the staybolts at the smallest section; maximum stress in the staybolts at the root of the thread; maximum stress in the crown bar rivets at the root of the thread, or smallest section, top and bottom; maximum stress in round and rectangular braces; maximum stress in the gusset braces; shearing stress in the rivets, and the tension on the net section of the plate in the longitudinal seam having the lowest efficiency.

### FAILURE OF RIVETED JOINTS

The first thing to be determined is the strength of the different seams, both longitudinal and circumferential. It is necessary to calculate each of the seams. In connection with the failure of riveted joints, there are five modes of failure that will be considered as follows: Shearing of the rivets; tearing of the plate along the line of rivets; tearing of the plate between

Table 1 gives the value of rivets in single shear and covers a range in shearing strength from 38,000 lb. to 50,000 lb., the driven rivet or rivet hole being based on 1/16 in. larger diameter than the initial size of the rivet.

Table 2 gives similar information for rivets in double shear, the value being 1 3/4 times that of single shear. If it is desired to base the value equal to two, the figures shown in Table 1 can be doubled. While, as mentioned above, the Interstate Commerce Commission allows a value for rivets in double shear equal to twice that of single shear, it is the practice of some of the state boiler commissions to allow a maximum value of 1 3/4.

To supply the information called for on boiler form No. 4, the first step is to ascertain the efficiency of the seams. The rules adopted by the Railway Master Mechanics' Association in 1895 cover the five methods of failure for a riveted joint; the first two mentioned above, generally give the weakest condition. There are cases, however, where the joint may be weaker under



either of the other three conditions mentioned, especially in connection with boilers built a number of years ago, when the boiler foreman was the designer as well as the builder. Now

that this work is generally performed by skilled designers, standard practices are followed and standard seams are established. It may be necessary, therefore, in many instances to figure at

TABLE 1—SHEARING VALUE OF RIVETS (DRIVEN SIZE)

Table with columns for Diameter of Rivet (Inches), Driven Rivet or Rivet Hole (Diameter, Area), Single Shear, and Ultimate Shearing Strength (Lb. per Sq. In.) ranging from 38,000 to 50,000.

TABLE 2 SHEARING VALUE OF RIVETS (DRIVEN SIZE)

Table with columns for Diameter of Rivet (Inches), Driven Rivet or Rivet Hole (Diameter, Area), Double Shear = 1 1/2 Times Single Shear, and Ultimate Shearing Strength (Lb. per Sq. In.) ranging from 38,000 to 50,000.

TABLE 3—SAFE LOADS ON STAYBOLTS

Table with columns for Diameter in Inches, Threads (No. per inch, Sharp, Depth, Diam. at Root), AREA (At Body, Root of Thread), and SAFE LOAD AT STRESS PER SQ. IN. OF (4,000 to 9,000 lb.).

least four modes of failure in order to obtain the lowest efficiency. In figuring the strength of seams, the driven diameter of the rivet is generally used, although the writer has recently come in contact with some information in connection with one of the boiler commissions, which allows only the initial size of the rivet to be used. The allowance generally considered is 1/16 in. larger than the initial size of the rivet, although some practices recently adopted have reduced this to 1/32 in. increase; it would therefore be necessary, in calculating the efficiencies, to use the practice in vogue.

Formulas 1 to 8, cover the different steps for calculating the stresses as outlined. After obtaining the weakest conditions, the efficiency is then found by dividing this value by the value of the solid plate (No. 1). A well designed longitudinal seam should run about 85 per cent to 92 per cent efficiency. The diamond seam, such as is used by the Baldwin Locomotive Works, gives a very large efficiency, running from about 95 per cent to 98 per cent. The circumferential seams are lower in efficiency than the longitudinal, running 60 to 70 per cent.

EFFICIENCY OF THE JOINTS

The meaning of the reference letters in the various formulas is as follows:

- A = Area of driven rivet or rivet hole.
- C = Crushing strength per square inch.
- D = Inside diameter of boiler.
- d = Diameter of rivet holes.
- e = Efficiency of riveted joint.
- f = Factor of safety.
- h = Margin (distance between edge of plate and rivet hole).
- L = Length of repeating section in inches.
- n = Equivalent number of rivets in single shear in a repeating section.
- O = Pitch of rivets.
- P = Boiler pressure (pounds per square inch).
- R = Shearing strength per square inch of plate.
- r = Radius of boiler.
- S = Shearing strength per square inch of rivet metal.
- s = Stress in plate per square inch.
- T = Tensile strength of plate per square inch.
- t = Thickness of plate in inches.

The ultimate tensile strength of steel plates is based on 55,000 lb. per sq. in. where actual figures are available. Where actual figures are not available, a tensile strength of 50,000 lb. is used. The ultimate tensile strength of wrought iron plates is based on 45,000 lb. per sq. in.

The shearing stress of steel rivets in single shear is taken at 44,000 lb. per sq. in. and 88,000 lb. in double shear. The shearing stress of iron rivets in single shear is taken at 38,000 lb. per sq. in., and 76,000 lb. in double shear. The shearing stress of a plate is considered to be the same as its tensile strength. Rivets in double shear are considered to be equal to two rivets in single shear. In calculating the strength of riveted joints, a length of repeating section is used, which is equal to the pitch of the outer row of rivets. The ultimate crushing value of steel plates and rivets is based on 90,000 lb. per sq. in.

- The strength of the solid plate =  $L \times t \times T$ .....1
- The shearing of one rivet =  $A \times S$ .....2
- Stress to tear the plate along the line of rivets =  $(O - d) t T$ .....3
- Stress to tear the plate between the rivet hole and the edge of the plate  
(one rivet) =  $\frac{4 T t h^2}{3 d}$ .....4
- Stress to crush the rivet or the plate in front of the rivet (one rivet) =  $(t d) C$ .....5
- Stress to shear the plate in front of the rivet (one rivet) =  $2 \left( \frac{d}{2} + h \right) t R$ .....6
- Shearing stress on rivets for a repeating section (lb. per sq. in.) =  $\frac{D P L}{2 n A}$ .....7
- Tension on the net section of the plate in the longitudinal seam (to be calculated for the seam of lowest efficiency) =  $\frac{D P L}{2 (L - d) t}$ .....8

BURSTING PRESSURE

The pressure required to rupture a cylindrical boiler is

- Longitudinal seam,  $P = \frac{T t}{r} e$ .....9
- Circumferential seam,  $P = \frac{2 T t}{r} e$ .....10

Note.—It will be noted that a circumferential seam is just twice as strong as a longitudinal seam.

While this gives the pressure at which the boiler would fail, a pressure considerably below this must be adopted to insure safety. So far, it seems to be the object of the Interstate Commerce Commission to encourage a factor of safety of four; in fact, this was fixed for all locomotives constructed after January 1, 1912.

The safe working pressure is then found by substituting the required factor of safety in formulas 9 and 10, which then become as shown in formulas 11 and 12, as follows:

- Longitudinal seam,  $P = \frac{T t}{r f} e$ .....11
- Circumferential seam,  $P = \frac{2 T t}{r f} e$ .....12

The thickness of plate may then be found by the following formula:

$$t = \frac{P d f}{2 T e} \dots\dots\dots 13$$

The stress in the longitudinal and circumferential seams may be found as shown in formulas 14 and 15:

- Longitudinal seams,  $s = \frac{r P}{t}$ .....14
- Circumferential seams,  $s = \frac{r P}{2 t}$ .....15

STRESS ON STAYS

When calculating the area of the unsupported portion of the backhead and front tube sheet, to obtain the stress in the stays supporting them, some authorities allow more to be supported by the flange of the sheet than others. By referring to Fig. 1 it will be seen that an allowance of 3 in. is shown. This is the space most generally used, although it has been assumed by some designers to be as high as 6 in. Theoretically, the area to be supported would begin at the point where the curve joins the straight sheet.

The greater the angle of the supporting stays on the backhead and front tube sheet, the greater will be the stress in the stays.

For convenience in calculations the value of  $\frac{(1.13)^2}{D}$  in formula 16, is given for stays ranging from 1 in. up to 1 5/8 in., as shown in the table.

In calculating the area of the front tube sheet to be supported, there is a diversity of opinion, particularly in regard to the hole in the sheet through which the dry pipe passes. The height of 2 in. above the line of the tubes seems to be generally used for the lower line of the segment to be supported, and 3 in. in from the flange has also been considered good practice.

Some authorities make allowance for the reinforcing ring around the dry pipe in the hole in the front tube sheet. This gives a surface equal to the area of a circle equivalent to the outside diameter of the reinforcing ring for the dry pipe. Others allow only for the hole itself, or half of the hole, or an arbitrary percentage of it. The various locomotive builders differ on this, and each uses a different value. The writer also knows of a case where it was argued that no allowance should be made, the claim being that the hole was unbalanced, due to the fact that the steam pipe was open to the atmosphere. To offset this, it would appear that there should be taken into consideration the



fact that the standpipe is securely anchored in the dome, the heavy reinforcing ring around the hole in the tube sheet, which also comes up close to the flange, the resistance offered by the steam pipes in the smoke box, etc., and that these would about equalize this condition. It is believed that after summing up the different conditions, if the hole in the sheet is disregarded, or the area of the segment minus the area of the hole is used, it will give a result which will be practically realized. In actual practice there seems to be very little trouble experienced with the failure of the diagonal braces on the front tube sheets, and after all this is not the most important part of the design, as the flat sheets themselves, as well as the T-irons and angles, offer some support which is not taken into account in any of the calculations.

Let  $T$  equal the stress in the stay;  $A$ , the area supported by the stay;  $P$  the boiler pressure, lb. per sq. in.;  $B$  the diameter of the stay in inches.

In calculating the stress in the stays supporting the segment on the backhead and the front tube sheet it is considered in the following analysis that each stay supports an equal area. When the area of the segment is determined by a planimeter, taken from a drawing known to be accurate and to scale, the result obtained should be multiplied by the square of the scale of the drawing, e. g.:

If the scale of the drawing is  $\frac{3}{4}$  in. to the foot, or  $\frac{1}{16}$  size, the actual area of the segment would be equal to the planimeter reading multiplied by 16 squared, or 256.

$$T = \frac{A \times P}{\text{Cos. } C} \times \frac{(1.13)^2}{D} \dots\dots\dots 16$$

$$\text{Cosine } C = \frac{B}{D}$$

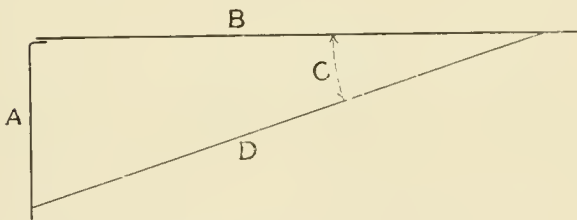

CONSTANTS FOR VALUE OF  $\frac{(1.13)^2}{D}$

1 in. diameter stay.....	1.28
1 1/8 in. diameter stay.....	1.008
1 1/4 in. diameter stay.....	.817
1 3/8 in. diameter stay.....	.676
1 1/2 in. diameter stay.....	.567
1 5/8 in. diameter stay.....	.482

The area to be braced in the front tube sheet is equal to the area of the segment minus the area of the hole  $A$  for the steam pipe as shown in Fig. 1. Two inches is allowed above the top row of tubes for the area supported by them.

The same conditions exist on the backhead when calculating the area of the segment, except that the lower line of the segment  $XY$  is considered to be half way between the top row of firebox stays and the bottom row of diagonal or flue stays.

FORMULA FOR CALCULATING AREA OF SEGMENT

Let  $A$  equal the area of a segment;  $H$ , the height, and  $R$  the radius. Then

$$A = \frac{4 H^2}{3} \sqrt{\frac{2 R}{H}} = .608$$

STAYBOLTS

The next subject to take into consideration is the stress on the staybolts. Diagram  $A$  in Fig. 2 represents the actual conditions that exist in the firebox; that is, the actual area supported by one stay is the square of the pitch (if equal) minus the area of the stay. The general method, however, is to consider the

area as represented by  $B$ , or equivalent to the square of the pitch, disregarding the area of the stay. The  $\frac{3}{16}$  in. tell-tale hole in the outer end of the staybolt, while actually decreasing the net sectional area of the stay, is generally disregarded.

The Whitworth screw-thread is now being used quite extensively on staybolts. The difference between the Whitworth and the V thread is that the Whitworth thread has a rounded section at the top and at the root of the thread, while the V thread is sharp at the top and the root. The angle of the Whit-

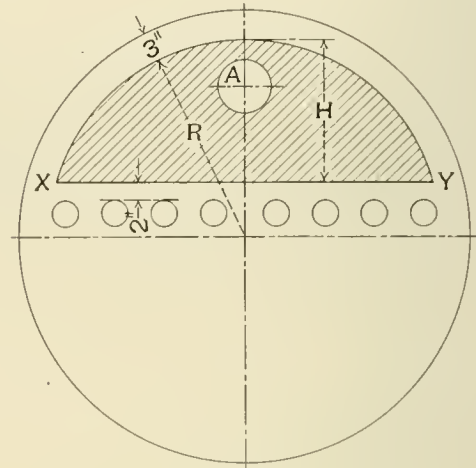

Fig. 1

worth thread is 55 deg., while that of the V is 60 deg. The relative life and strength of staybolts provided with either of the two threads mentioned has been determined through test. In a vibration test each bolt was screwed and riveted in a  $\frac{1}{2}$ -in. steel plate in the same manner in which staybolts are secured to the boiler. Each bolt was given a vibration of  $\frac{3}{8}$  in.; the average number of vibrations withstood by the V thread staybolt was 1,485, while the average for the Whitworth thread staybolt was 3,437. In a second series of tests, each bolt was given 10,500 vibrations through an arc of  $\frac{3}{16}$  in., and then vibrated to destruction through an arc of  $\frac{3}{8}$  in. In this case the V thread staybolt averaged 791 additional vibrations, while the Whitworth thread failed at 1,932 vibrations. One very noticeable feature of the test was that the Whitworth thread staybolts held to the sheets much tighter than the V thread bolts, and also showed no tendency to cut into the sheet.

Bending tests were also made and in these the V thread failed when bent over a 3 in. diameter pin, while the Whitworth thread

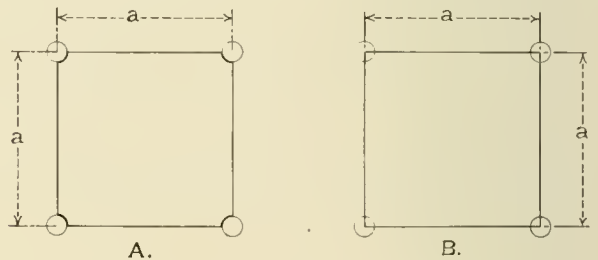

Fig. 2

bolt withstood a bending over a 2 in. diameter pin, but failed when bent over a  $1\frac{7}{8}$  in. diameter. These tests indicate the theoretical superiority of the Whitworth thread for staybolts, while the practical superiority has been demonstrated by the great decrease in broken staybolts on several roads which have adopted the Whitworth thread as standard.

Table 3 gives the safe loads on staybolts for various stresses and diameters, and covers figures for both the sharp V thread and the United States standard thread, with both 10 and 12 threads per inch.

The formulas for deriving the diameter of the staybolt at the bottom of the thread for the V and the Whitworth threads are as follows:

$$\begin{aligned} \text{(V thread) } d &= D - (P \times 1.732) \\ \text{(Whitworth thread) } d &= D - (P \times 1.2807) \end{aligned}$$

where D = outside diameter of the bolt,  
d = diameter at the root of the thread,  
P = pitch of the thread.

CROWN STAYS

The next subject is that of crown stays. In calculating the stress on the crown stays, the same general conditions apply as in the case of the ordinary staybolt. It will be noted from

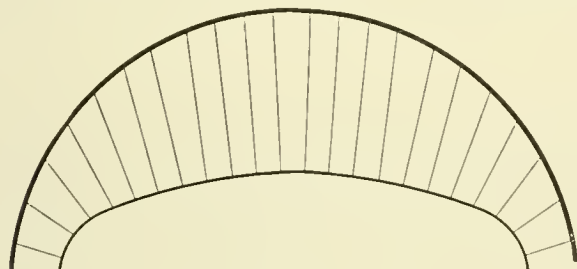

Fig. 3

Fig. 3 that the area of the portion supported on the outer end of the crown stays is greater than the area supported on the lower end, and in calculating the stress, the area at the crown sheet or lower end of the stays should not be considered.

GIRDER STAYS

In calculating the value of girder stays where there is a bearing on the top edge of the side sheets, the girders are considered as a beam, uniformly loaded and supported at both ends. A fiber stress of 17,000 lb. is allowed as the maximum stress in the girders; all above this amount is considered as being transmitted and carried by the slings connected to the roof of the boiler.

The following formulas are used in calculating the stress on girder stays and sling stays:

$$\begin{aligned} W &= L \times O \times P \\ W_1 &= \frac{f \times s \times b \times d^2}{L \times 6} \\ S &= \frac{W - W_1}{n \times a} \end{aligned}$$

- where a = area of driven rivet;
- b = width of girder stay;
- d = depth of girder stay;
- f = fiber stress (assumed 17,000 lb.);
- L = span of girder;
- n = number of rivets per girder stay;
- O = pitch of crown bolts;
- P = boiler pressure;
- S = stress per square inch in rivets;
- W = total load supported;
- W<sub>1</sub> = weight supported by girder (at fiber stress of 17,000 lb.).

RECORD KEEPING.—One of the important duties of an editor of this paper is to visit power plants for the purpose of obtaining first-hand information on actual operating conditions. These visits reveal, among many other things, a lack of record keeping of plant performances that is astonishing in view of all that has been said and shown to emphasize the importance of the practice. And this paucity of recorded information is not confined to small plants. It exists in plants where the opposite conditions would be expected. Then, too, plants are found where the multiplicity of record and report forms would bewilder a confirmed systematizer. Often this condition is temporary, for it proves difficult in practice to arrive at the most suitable forms without having come to them by the adoption and elimination of numerous others. The condition is then excusable.—Power.

## TRAINING MEN FOR ENGINE HOUSE WORK

BY CHARLES MAIER

One of the most difficult problems that the roundhouse foreman has to solve is that of maintaining an organization of thoroughly competent and reliable men. While the principal trouble in this direction is in regard to mechanics, it also applies to the rest of the trained labor, such as hostlers, inspectors, etc. It is bad enough with the day force, but it is even worse with the night force. The nature of the work, and the conditions under which it must be done, require much patience and endurance. This drives the best mechanics to the back shops, and the more intelligent laborers into other lines of work. As a result it is often necessary to hire for laborers a class of men who cannot speak the English language, or who speak and understand it so poorly that it is difficult to understand them, or to make them understand what is being said. On account of this it is a difficult matter to judge a man's intelligence or to judge what line of work he is best suited for. Such men often turn out to be the very best kind of men for engine house work, but on the other hand many of them would never rise above laborers.

It is just as necessary for a roundhouse to have an intelligent class of laborers as it is to have good mechanics. Considerable has been said and written about the training of apprentices and excellent results are being obtained, but apprentices do not, as a general rule, come to the roundhouse after they have finished their training. The long hours and difficult working conditions do not appeal to the average apprentice graduate, and he generally selects the back shop for his future. This makes it necessary to train roundhouse mechanics from the force at hand, and if this force is made up of poor material a poor set of mechanics is the result.

Many intelligent young men start work in a roundhouse with the intention of going firing and becoming enginemen. These young men are often used on roundhouse jobs that require special training, and about the time they become useful they are sent out firing. This makes some foremen avoid hiring men who are eligible as firemen, as they prefer men who are apt to stay after they are trained. There should be no trouble in obtaining intelligent, ambitious laborers to work in roundhouses. There is more chance for advancement for them and the work is steadier than in any other branch of railroad work. The fact that the roundhouses cannot attract the better class of laborers shows there is something wrong. Young men who are doing clerical work hesitate before taking a laboring position because they cannot see anything definite in the way of bettering their condition. If such men could be given a definite promise that after they had acquired a certain amount of knowledge and skill they would be given the first opening for promotion they would be apt to stay, feeling that as there was something to work for they could overlook the discouraging features that might otherwise drive them to some other line of work.

All the laborers hired in a roundhouse cannot become mechanics, and some of them never could be made into mechanics, but they probably could be made to fill other responsible positions satisfactorily. With a regular system of examinations conducted annually, or oftener if found desirable, the men could be assigned to work for which they show a special aptitude, and they would then feel that they are going to amount to something. This would also have a tendency to make them pay more attention to their work and to take a greater interest in it. In most roundhouses it is the custom to promote men as vacancies occur, but there is no definite method except that the foreman uses his judgment. In doing this he may promote a man comparatively new in the service because of this man's superior ability, and this causes dissatisfaction among some of the older men who probably feel that they could handle the work as well. These men in turn speak to newly hired men and tell them there is no chance for



them around that place, citing their own case as an example. Another thing in connection with this method of promotion is that the men ask for positions on account of the immediate increase of wages they will receive, without looking ahead to a possible chance of being better off in the end. In this way many a man who might have become a good mechanic goes to the ash pit as a hostler instead. He probably was a helper in the shop and doing his work well and conscientiously when the opening for a hostler's position occurred. Because this position pays more than the one at which he is working, the man is induced to ask for it, and when he obtains it he probably can advance no further.

Now if this man had known that after he passed certain examinations he would be eligible for advancement until he was classed as a mechanic, he probably would have let the position of hostler go and aimed for the higher place. To make this system more effective, all the men working in roundhouses on one division should be classed in a pool. Thus, the man working in the small roundhouse would have an equal opportunity with those in the larger ones. On the other hand, the small roundhouse would be assured of having a capable man if one of the small force employed there were to leave. This would necessitate the keeping of a record of the men in the division master mechanic's office, and it would give him a complete record of his working force and their ability.

In following such a plan there should be eight grades, from the position of laborer to that of a first-class, all-around mechanic. Each grade should have a rate higher than that of the preceding grade by an amount equal to one-eighth of the difference between the pay of a laborer and that of a first-class mechanic. The length of time a man must work in each grade would be determined by the demands of the service, but there should be a minimum time of at least six months, and in some of the higher grades at least one year. A laborer starting in to help mechanics should be put on probation for six months to see if he is adapted to that kind of work. He should in this time get a knowledge of where to go for various tools and supplies and obtain a general idea of what is required of a helper. If he is found to be qualified he should then be advanced to the first grade. Here he would be expected to learn such things as the sizes of nuts and bolts, sizes of pipes, how to cut threads with dies, the difference between rough and fitted bolts and where and why each kind is applied to an engine. He should know about which tools will be required for various jobs and should be able to do ordinary tightening up work. After he has actually done all of this kind of work and can give a satisfactory explanation of it, he would be eligible for the second grade. Here he should learn to grind in and pack globe valves, etc., renew joints in pipes, renew tank hose and brake shoes, take out and repack grease cellars, etc. Each grade would thus cover certain classes of the roundhouse work.

To receive the pay of the eighth grade a man should be so proficient in all-around repair work that he can be relied on to go ahead with any kind of a job given him. In this outline no attempt is made to enumerate each kind of job that a man might be called on to perform. It is not intended that a man in any one grade should be confined to the work outlined for that grade, but before he can be advanced to a higher grade he should have actually handled on his own responsibility all the work covered by the grade he is in. The fact that he has worked with a higher-grade man and helped him do this work should not be considered sufficient reason for advancement. Helping a machinist can be almost anything that the helper makes it. He may only help when a lift or pull is required, or may not make a move except when he is told. A man of this kind should not be compared with one who goes ahead just as though the job depended on him. The candidate for each higher grade should be able to give an intelligent oral explanation of the work, and he should be trained to look for the causes that made the repairs necessary. It should be considered evidence of poor workman-

ship for a mechanic to make repairs and not search for what made the repairs necessary, where this is possible. For example, it is poor workmanship for a mechanic to repair a leak in an air pipe and leave the pipe brace loose, allowing the pipe to vibrate so that it invites another leak and perhaps causes a broken pipe.

This system of grading and examining men would have a tendency to make them observing. Knowing that they will be examined, but not knowing just what the questions may be, they would form the habit of paying closer attention to their work. The outline of work given applies to machinists, but the same principle can be applied to all roundhouse men. This should result in a better trained and more satisfied body of men than can be obtained under present methods.

## BUYING BRUSHES ON SPECIFICATIONS

BY H. M. BAXTER

While the purchase of paint and other brushes on the basis of blue prints or specifications is growing less general, it is still more frequently used than it should be. The term "best quality" of any sort of bristle generally included in the specifications is misleading at best and in these days of constantly advancing prices, it is a condition almost impossible to fulfill. It is further absolutely impossible to define, in words, just what solidity and grade of bristle is desired. A sample is necessary to show that. And when it is required, besides matching the sample in quality, to meet precisely all the measurements given in the specifications, it makes a special brush all through, except for the one company who supplied the standard samples. This is where the great objection lies to printed or blue-printed brush specifications. It tends to destroy competition. The manufacturer furnishing the standard samples possesses an advantage both in having the correct sizes and shapes as well as in knowing just what mixtures and qualities of bristle or soft hair are in the brushes.

The fairest way to purchase brushes as well as the best way for the railroad to receive the maximum competition and value, is to order, from several manufacturers, samples of their standard brushes most nearly in conformity with the specifications or needs, in size, shape, style, and method of construction, as well as color, quality, quantity and length of bristle. Those samples should all be tested in actual work and the results made a matter of record, as so many hours of actual service or square feet covered or gallons applied or whatever other unit may be selected.

Such a method, with its ensuing tests, would undoubtedly credit some features to different firms according as their samples proved out in service. This might not be any undesirable result. Tests could be made occasionally during the regular course of work with no additional cost to the railroad by simply keeping a record of how many units were accomplished by certain brushes. By having tests made by the various departments all over the system, a more or less constant check could be kept by compiling them in tabulated form, and by keeping a record of at least one brush from each shipment. It could thus be ascertained whether or not the manufacturer was keeping up his standard. In cases where, for any reason, an impartial test would seem difficult to procure, it would be advisable to purchase several samples of each brush, erasing all names and marks therefrom and giving each manufacturer an identification number, to be kept as a secret record until the completion of the tests. One such numbered set would go to each shop where painting is done. The reports from the different shops would serve as a most effective check on each side. One unit of service should be used throughout the series of tests and it is probable that the hours of actual service is best adapted to the purpose of comparison.

# CAR DEPARTMENT

## RECLAIMING JOURNAL BOX PACKING

BY ALDEN B. LAWSON

The illustration shows a convenient layout for a plant for reclaiming old journal box packing and a type of cleaning vat which has been fully tried out and gives excellent service.

The vat is made of No. 16 gage galvanized iron and is an inner vat within an outer one, there being a 4 in. space between the two at the bottom, sides and ends. This space is filled with



Equipment Used in Reclaiming Journal Box Packing

water to the height of the oil and packing in the vat, and steam passing through eleven 1 in. pipes at the bottom, boils the water and heats the oil and waste. At one end of the vat is the cold water and steam inlet as well as the water height gage, while

through as it leaves the old waste which is stirred occasionally while under the boiling process. The vat is divided into two compartments by a partition in the center. The waste is first heated in one compartment and the oil pressed out, and it is then heated in the second compartment.

Drawings are also given of the press and drip pan used with the equipment. A bucket made of smoke box netting, substantially braced with wrought iron bands, is employed, and the pressing is done by an air cylinder, arranged vertically with a plunger fitted inside the bucket. A building 10 ft. by 25 or 30 ft. is large enough for this work, unless it is desired to store

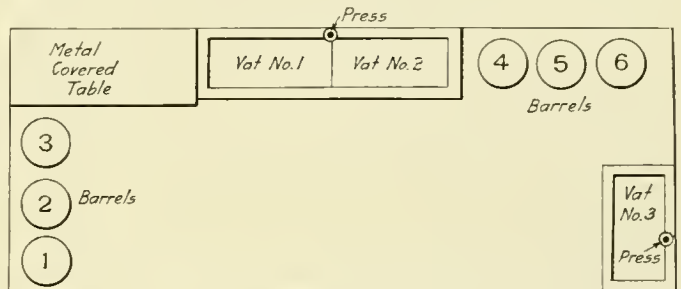

Plan of Building Showing a Convenient Arrangement of the Vats, Barrels and Press

the material for a time before using. The building should be isolated to avoid danger in case of fire.

The work can be done by two men, one for each vat. A third vat is generally used by the journal box packers for soaking their packing. These vats will handle about ten barrels of waste daily and it will be found advantageous to locate them at the main car repair yards and have shipments made to these main

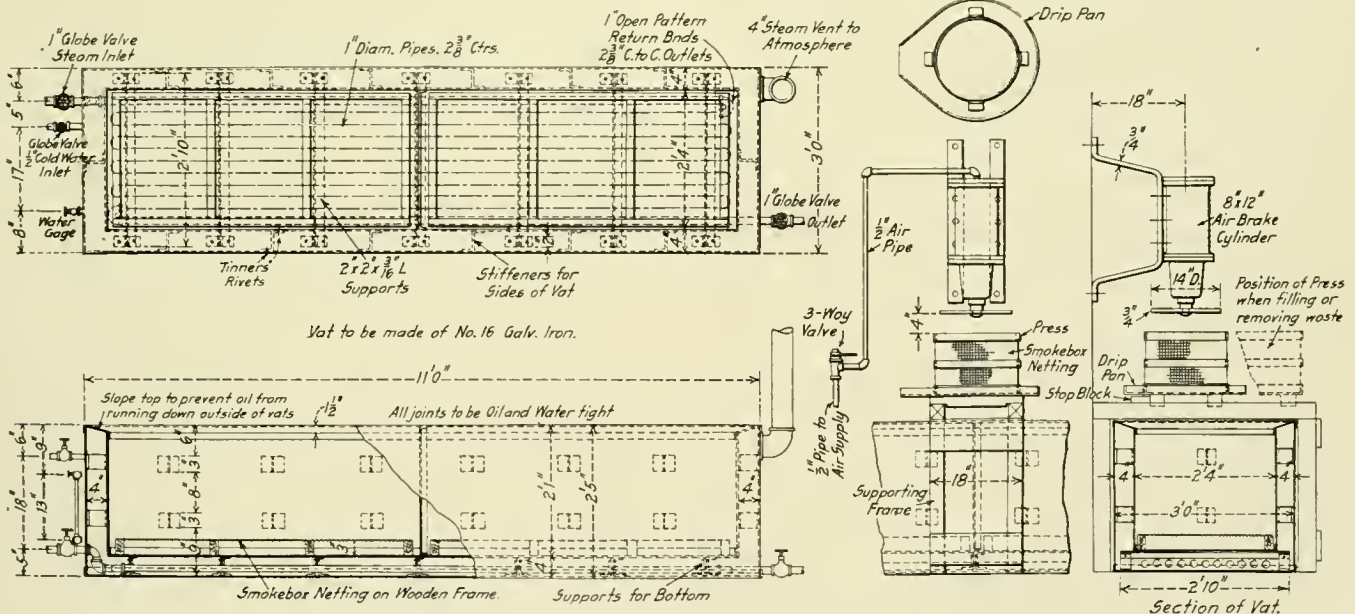

Details of the Vat and Press Used in Reclaiming Packing

at the opposite end is a steam outlet to the atmosphere and a water drain or outlet.

The top edge of the vat is sloped toward the inner vat so that drippings will drain inward. On the bottom of the inner vat is a screen of smoke box netting resting on wooden supports 3 in. high. This permits the dirt and sediment to drain

stations from small outlying points in barrel lots, sending one barrel of waste for each one received.

A brief description follows of how the work should be done: Old waste to be reclaimed should be spread out, preferably on a metal covered table or platform, where it can be shaken out with pitchforks to remove foreign matter and all short waste



unfit for use. When knots and tangles are found they should be removed by hand, after which the waste is ready to be put in the first vat. In this vat there must be enough oil at a temperature near the boiling point, to cover the waste, which remains in it for not less than half an hour. It is then taken out and placed in the press bucket and the oil pressed out, the oil draining back from the drip pan into the vat from which the waste was taken. The waste is then placed in the second vat and again boiled in oil for half an hour, after which it is taken out, pressed and put in barrels ready for shipment, or taken to the third vat to be soaked in oil for use by the journal box packers. In pressing packing, the oil drainage from the waste should be deflected to the vat from which the waste was taken, as the oil in the second vat will be much cleaner than that in the first one.

Both cleaning vats are in use continuously. In the plan of the building it will be noted that there are six barrels. Those numbered from one to three are used for vat No. 1 and barrels four to six for vat No. 2. When vat No. 1 requires cleaning, which will be when the oil is thick from sediment, the oil should be dipped out and placed in barrel No. 1, where it should remain for 24 hours; then it should be dipped out and placed in barrel No. 2 and remain there 24 hours. It is then transferred to No. 3 where it remains until needed for use in vat No. 1. Dipping is resorted to in order to prevent stirring up the sediment at the bottom of the barrels, and neither vat should be continued in service more than 72 hours. The second vat is managed in the same way.

If there is more oil in barrel No. 3 than is needed for vat

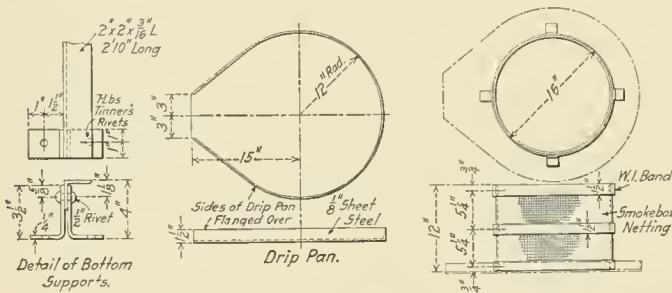

Details of the Drip Pan and Press Bucket

No. 1, it may be placed in barrel No. 4 and so transferred up until it passes through barrel No. 6, when it may be used in vat No. 2. It can also be used in vat No. 3 for soaking the packing for journal boxes, but if so it should be filtered. New oil from the oil supply house should never be placed in vat No. 1. If it becomes necessary to use new oil because of an insufficient quantity reclaimed, it should be used in vat No. 3 and in vat No. 2, in the proportion of about 50 per cent of new oil and the same amount of old oil. If barrel No. 3 does not supply a sufficient quantity to care for vat No. 1 and there should be an over supply from barrel No. 6, this should be used in vat No. 1. New oil should never be used in this vat.

Any arrangement may be adopted to suit the operator, but the oil in each vat should be transferred at least three times and allowed to remain at least 24 hours for settling before being used.

The sediment taken from the bottom of the vats and barrels may be used as a lubricant for center plates and side bearings. However, it will be found where there is a large quantity of waste reclaimed that there will be a great accumulation of this sediment, and it is recommended that it be further treated to obtain all the oil possible from it. This may be done by placing a steam heat coil in a barrel in which the sediment is placed, and thoroughly heating it, permitting it to pass through an outlet cock to a funnel screen of fine mesh. By scrubbing the sediment with a bristle brush against the screen, it will be found that a considerable quantity of the oil may be reclaimed and the sedi-

ment reduced to a minimum. The oil obtained may be placed in barrel No. 1 and carried through the settling process as described above for use in the vats. If too much sediment is obtained, it should be used as a lubricant where possible, but it will not be a great loss to throw it away.

By the use of this method fully 80 per cent of the old packing is reclaimed, and a considerable quantity of oil is obtained at a very small cost for operation.

## FOREIGN CAR QUESTION\*

BY D. J. DURRELL

What constitutes revenue freight car equipment? On Classification of Equipment, Form 7, on file in the office of the general agent of the American Railway Association, at Chicago, for the month of June, 1913, is the following data, taken from the replies of 160 roads operating 232,408 miles:

Type of cars	Number in service
Box	1,095,727
Refrigerator	51,974
Stock	81,809
Tank	12,365
Flat	139,866
Dump	35,126
Steel hopper	205,661
Wood hopper	128,270
Coke	38,054
Steel gondola	155,843
Wood gondola	292,252
Other revenue	29,708
<b>Total</b>	<b>2,266,655</b>
Caboose, work, etc.	129,342
<b>Grand total</b>	<b>2,395,997</b>

On October 1, 1913, the actual number of revenue freight cars owned by railroads was 2,360,574. This is for all the railroads in the United States and Canada. These cars were located as follows:

Home cars on home roads	1,292,158
Home cars on foreign roads	1,068,596
Home cars in home shops	144,568
Foreign cars in home shops	32,546

For the year ending October 1, 1913, there had been—putting it in this way, “One car, so many days out of service on account of bad order”—53,309,507 car days, or an average number of days that each car was out of service during the year, of 22.53.

Dividing the United States and Canada into 11 districts and taking the number of cars owned by the lines in each district, we find that of all the cars, the location in per cent of the total cars is:

	Min.	Max.	Avg.
Home cars on home roads	36.37	67.63	54.73
Total cars on lines	89.31	143.35	102.91
Home cars in home shops	2.69	8.01	6.12
Foreign cars in home shops	.33	3.02	1.38
Total in shops	4.87	11.03	7.50

By these figures you will note that the average number of cars owned, that is, home cars at home on their own road, was but 54 per cent of the cars owned. Also that the total cars used compared with those owned varied from 89 to 143 per cent, an average of 102 per cent; in other words, some roads used 43 per cent more cars than they owned. These figures seem large, but they have been verified by reports from the American Railway Association and I feel that they can be depended on. This means a great deal to the railway companies. Take the 32,546 foreign cars in home shops. At a per diem charge of 45 cents, this amounts to \$14,645.70 a day; or for a 365 day year, \$5,345,680 for per diem charges. Someone may say that the five million dollars thus represented does not leave the coffers of the railways; that it merely passes from one to another and back again. That is very true, but at the same time the cars have been out of service and considering that it is only one day that is taken as a basis, which everyone understands is far below the actual time that foreign cars are held on the repair tracks, we have run up a total yearly per diem charge of over five million dollars and additional days but add to this figure.

\*From a paper presented before the Cincinnati Railway Club.

# STEEL FREIGHT CAR REPAIR SHOPS

First Prize Article in the Car Department Competition Which Was Closed on February First

BY E. T. SPIDY

Assistant General Foreman, Canadian Pacific, Winnipeg, Man.

In consideration of the fact that each railroad has a different number of steel freight cars to be handled each month, relative to the size of the road, I intend to deal with the subject in the manner of a new problem, putting down as clearly as possible every consideration to be made with a view of maximum output in conjunction with low shop cost. This will enable anyone studying the subject to apply the conclusions to his shop and his conditions, and thereby obtain the best solution for his individual needs. Incidentally I am recording to a degree the actual development of this work on the Canadian Pacific at Winnipeg. We have learned that the only way to really get to the bottom of any problem is to analyze it and then to reconstruct along the lines of good judgment and practical knowledge. Therefore, knowing what our problem is, viz., repairing steel freight cars, I will proceed to tabulate all considerations that must be taken into account and afterwards study each in detail.

*Location of Building.*—Type of shop required; its relation to other shops and general stores; its relation to the yard; its relation to the special supply storage for structural steel, wood, couplers, etc.; facilities for delivery of material; provision for future extension; provision for further developments in cars.

*Structure of Building.*—Size of building and general construction; large span of roof compared with short spans; light, heat and sanitary considerations.

*Layout of Shop.*—Departmental operations: structural steel, blacksmiths, machine work, brake beam work, trucks, woodwork, paint department, etc., office, petty stores and tool room, lavatories and industrial tracks.

*Shop Equipment.*—Importance of good equipment; machinery required for various operations; special machinery; pipe and power lines.

*Operation of Shop.*—Shop organization; methods of repair; inspection, classification of repairs, reports, etc.

*Location of Building.*—There are two types of shop that need especial consideration, viz., longitudinal and transverse. In the first we have a series of long tracks, each of which will accommodate six or more cars, and in the other all tracks are independent and parallel leading out to a transfer table. While the latter is more universal in passenger car shops, it is not an efficient means of transfer for freight cars, because the movement is quicker; that is, they are in the shop a much shorter period and a transfer table is too slow when any number of cars are to be handled. The longitudinal shop, on the other hand, allows a whole track to be drawn at one time. It is not very difficult to classify repairs so that cars which will be in the shop a longer time than others shall be in one section. At the Winnipeg shop, the arrangement is longitudinal and cars are drawn in strings of six or eight. The other end of the shop is served by the transfer table of the general car shop. This allows great flexibility for handling an individual car to be run into the car straightening frame and out again without disturbing the rest of the shop. This end of the shop, however, is not used to a great extent except for the introduction of supplies.

The location of the shop must be such that getting supplies from the general stores is convenient and it must be close to the structural steel rack. There must be sufficient space at the sides of the building to keep a stock of standard repair parts with room for industrial tracks. The importance of having the best possible facilities for the delivery of material cannot be over emphasized because, when the material element is defective,

the human element most certainly will lag behind in greater proportion.

It is also necessary to bear in mind that the steel car industry is in its infancy and at some future date extension will be necessary, so at the end away from the supply source the space should not be incumbered with buildings of any description. Also considering that in the future materials of a heavier nature might be used, good judgment is necessary that present space may prove not adequate for heavier machinery which may be demanded at some later date.

*Structure of the Building.*—While the material used in the construction of the building does not usually concern the shop engineer or superintendent, the general construction does in many respects. The capacity of the shop is of great importance to him and he must figure out how large a shop is required. We will suppose the present demand is for 60 cars to be repaired each month; then the average time a car will be kept in the shop must be decided. If it is 10 days, this gives us 600 car days a month. There are 25 working days a month and the number of cars in the shop at one time will be 24, or three tracks containing eight cars each. Allowing then for future extension, say 100 per cent, multiplied as per individual requirements, we have the size of shop to be built. It is not advisable to bring the tracks closer together than 22 ft. because room must be provided for industrial tracks for material delivery. A point to note also is that the construction of the shop roof is such that it will not interfere with the industrial track delivery. For instance, in a shop with six tracks the roof would either be made with one or two rows of posts in the shop. It will be seen that it is not practicable to run industrial tracks through the shop where the posts are, and as only one industrial track is required to reach two car tracks, with one row of posts four industrial tracks are required, whereas with two rows of posts only three industrial tracks are needed. In addition it must be remembered that the posts when placed between each two tracks are exceedingly convenient for leading down the pipe lines and also are handy to attach vises. Thus the posts of the shops, when arranged between each two tracks, are more convenient in every respect than larger spans.

The floor of the shop is of great importance, and in view of the many heating operations necessary on steel cars, it should be constructed of asphalt or other plastic surface about 2 in. thick, bedded on a layer of about 9 in. of concrete. This fireproof floor will well pay its extra expense in the small upkeep cost for repairs, and at the same time it is not at all hard on the workmen's feet.

The roof should be a structural steel type with as little wood as possible. So many crude oil burners which are used in every conceivable place make this precaution highly advisable. Another point worth more than ordinary consideration is daylight. The more daylight available, the better the work; artificial light is a poor substitute underneath a car, and all known methods of securing greatest length of daylight during working hours should be provided.

It is necessary to make provision for all operations to be performed in connection with the repairs undertaken and to provide machinery space. Briefly summarizing, there is drilling, threading of bolts and rods, blacksmithing, repairing brake beams and equipment, straightening structural steel, wood machine work, offices, etc., all of which require space; in addition they must be



easy of access to the shop. All new devices such as safety appliances are manufactured in the manufacturing departments on a larger scale, and stored ready for application. The best place for these small departments is obviously at the sides of the main shop in the form of a low extension. There should be one extension of this kind on each side of the shop and it should extend the whole length of the shop, and be not less than 18 ft. wide to allow of a central industrial track with space for the machinery on each side. The roof of the lean-to should be high enough to provide efficient ventilation. A general fault with most extensions is that they have been added some time after the main building was erected with the result that the daylight has been practically excluded from entering by the side of the shop. Steel car work demands good floor light, and so the pilasters and walls supporting the main shop should be as narrow as possible.

*Layout of Shop.*—It is necessary to make a complete list of all machinery that is required, including also that which will be required at a later date. The general machinery department and the blacksmith department work hand in hand and should be placed on one side of the shop. The brake beam department, where steel beams are straightened, forms a little group by itself

hammer is also required for this purpose. This will prevent work being taken to the larger blacksmith department and saves much time. The remaining part of this part of the extension can be confined to machine work of a general character.

The extension on the other side of the shop should contain the following units: The heating equipment and the lavatory are important and practically fix themselves as to location at the center of the shop. This then is also, by the same reason of accessibility, the best place for the petty stores and foreman's office. We now have two sections, one at each end of this occupied block, which are needed for the two remaining departments not yet provided for, namely, the structural steel department, where the straightening, punching and cutting can be done, and the wood and paint department which are comparatively small. Truck work is done on the track directly behind the cars from which they are removed and so does not require special space.

Industrial track service of an efficient nature is most necessary. We see from the general layout that in the arrangement shown the tracks run clear through the shop to turntables or smooth plates and around the shop making no undesirable twists and yet every car in the shop can be reached with ease. The end tracks may be made to cross inside the shop in very cold climates,

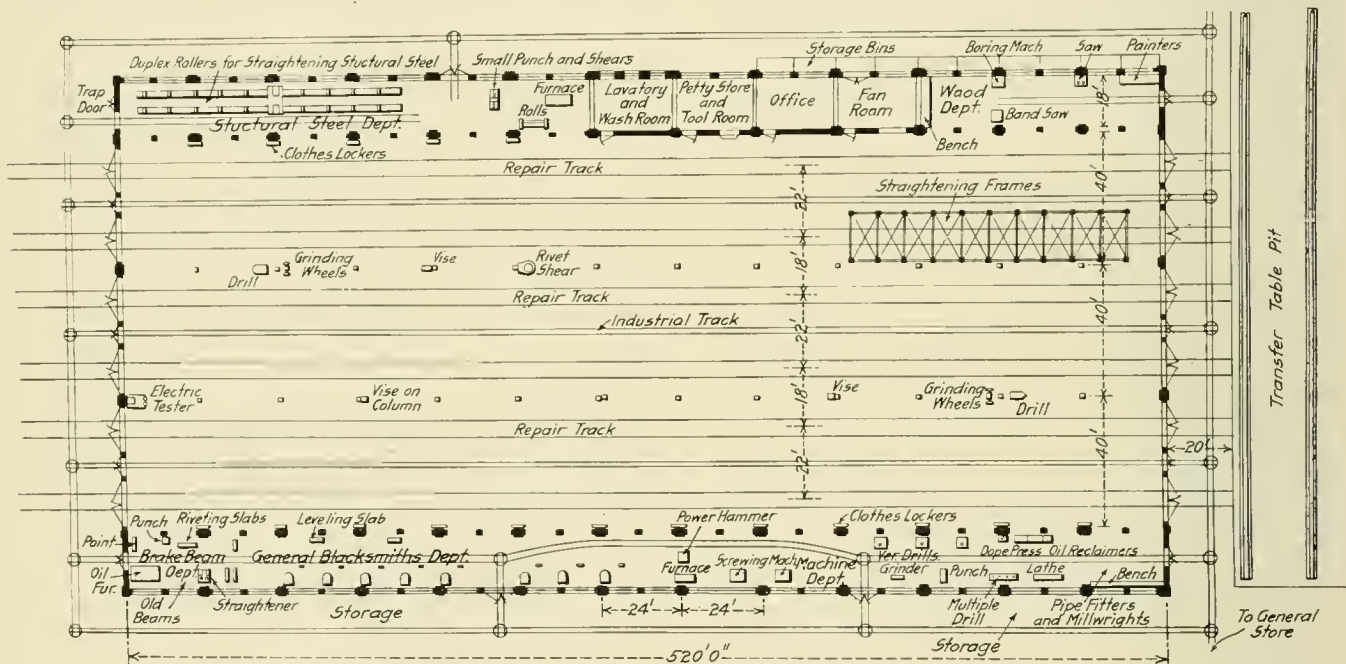

Plan of Proposed Steel Freight Car Repair Shop

and should be placed close to the blacksmith section. A very good location is directly in the end of the side extension. Brake beams are somewhat clumsy to handle and this position allows of minimum distance to travel, because they can be stocked outside the shop before being repaired and then brought in and removed when repaired without having to travel all the way down the shop.

The blacksmith work requires eight fires for a shop of this size. Blast must be provided at six or eight ounces pressure for the fires, and this should be carried underground in a tile pipe. The fan itself, which is a 24 in. diameter wheel, steel pressure type, can be placed on the wall, the air being sent directly downward into the floor pipes. Smoke hoods must also be provided for the fires, and the pipes on the hoods extended at least 10 ft. through the roof. In cold winter climates a better arrangement is to connect all the hoods to an exhaust fan giving about two ounces suction draft. This pulls the smoke from the fires and does not allow any cold drafts to enter the shop. The fires are backed against the outer wall and the other side of the track is used to deposit material. At the end of the row of fires should be placed an oil furnace for welding brake rods; a small power

but this is at a sacrifice of car repairing space. Outside tracks should connect with the main shop system of tracks wherever possible. Movable turntables are somewhat expensive items when any number are required, and a far cheaper method is to use a smooth plate. It is the general rule to find turntables stuck and most often no effort is ever made to loosen them up. We have found the smooth plates far more satisfactory in service and use them in all cases, except where very heavy loads are handled.

*Shop Equipment.*—We will proceed to detail the various operations by first making a list of machinery, as complete as possible. The machinery on this list may not be required at once, but may be looked on as the ultimate complete equipment required when the shop is running full capacity. The advantage of this lies in that it allows a definite location to be settled for what machinery is obtained, so that moving of machines is obviated when work increases so much that the additional equipment is required.

*Tools and Equipment:*

- Brake beam repairing outfit—*
- 1 Oil furnace, inside dimensions 10 ft. by 4 ft.
- 1 Brake beam straightening machine.
- 1 Straightening face plate.
- 1 Water plunge bath.

- 1 Pneumatic punch or single spindle drill.
- 4 Riveting tables or slabs.
- General blacksmith—*
- 8 forge fires complete with hoods, etc., water boxes, coal and coke bins, anvils, leveling slabs, etc.
- 1 Oil furnace, welding type, 6 ft. long, 2 ft. deep.
- 1 Power hammer (electric, belt or air driven), 250 lb. capacity.
- General machinery department—*
- 2 Triple head bolt threading machines, capacity up to 2 in. diam.
- 5 Single spindle drilling machines, capacity up to 2½ in. holes.
- 1 Multiple spindle drilling machine.
- 1 Lathe, 16 in. by 10 ft.
- 1 Pneumatic punch, capacity ¾ in. hole, ½ in. plate.
- 1 Dope press.
- 1 Oil reclaiming outfit.
- 3 Double floor grinders.
- 1 Portable shear.
- Structural steel and plate outfit—*
- 1 Double straightening roll for straightening bent rolled sections.
- 2 Steel car straightening frames.
- 1 Small hand roll.
- 1 Punch and shear.
- 1 Furnace 8 ft. long by 3 ft. wide.
- Wood machines—*
- 1 Wood boring machine.
- 1 Rip saw.
- 1 Band saw.
- General equipment—*
- Vises, hydraulic jacks, trestles, chains, benches, rivet fires, pneumatic hammer, drills and rivet busters, torches, shop trucks, hoisting blocks, etc.

The importance of good and complete equipment is very well recognized. Without losing any meaning in reference to first

water should be supplied at stationary fountains so that the use of cups is obviated. Fire hydrants should be placed conspicuously with hose reels ready for any emergency.

Oxygen and acetylene gas connections taken from main shop lines for oxy-acetylene welding and cutting should be made in this shop and pipe lines along the two center columns of the shop with drops for each gas made at alternate columns, these columns being those other than columns with air, oil and water connections. To ensure fool-proofness the oxygen and acetylene lines should end in every case with special keyless valves.

Considering now the different operations in the order named and the layout that will give the best results, the brake beam repairing outfit will do all repairs to steel beams. It will straighten bent beams, apply new beams, replace broken shoes, and attach all links and other gear required to the beam itself. Defective beams are removed from the cars in the shop and placed on a pile outside at a convenient point. New beams or repaired beams are delivered to another pile outside the shop. The layout shown in the plan has been developed in our shop and works very satisfactorily. The old beams are brought into the shop in batches and delivered in a pile by the side of the straightening furnace. Here they are stripped of broken shoes, or the detachable links are removed and the whole is placed in the furnace which will accommodate four or five beams at one time. As one beam is removed it is replaced by another, making the heating operation practically continuous. The beam after being removed from the furnace is then placed in the straightener, which

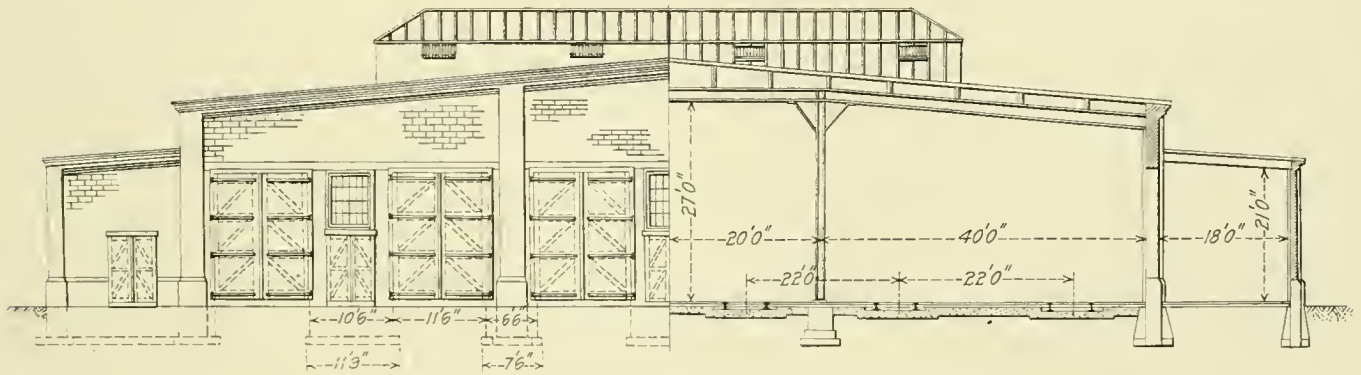

Section Through Proposed Steel Freight Car Repair Shop

class equipment, it may be considered that for the class of the work in hand some machines (such as drills for general use in the main shop) do not require to be recent models and equipment replaced in some other shop can be advantageously employed.

It is seen at once that power lines are required in the shop, electric power for the machines and for light. Individual drive is necessary on account of the scattered nature of the arrangement; this is generally most economical, but each case must be treated individually.

Compressed air is required all over the shop. Every alternate column in the shop and each corresponding wall pilaster should have a drop line with a combination connection to carry three hose lines. While the drops need only be ¾ in. pipe, particular care must be taken that the mains are large enough so that the supply is not throttled on the end of the shop farthest from the main lead pipe.

Fuel oil is required for furnaces and portable rivet fires. This must be piped to the machines direct from a supply tank by gravity flow or by a pump. Pipe lines should be run through the shop by way of the steel columns only, with drops at alternate posts; the post with oil connections should be the same as those connected with compressed air, because all portable fires require air and oil both.

Water requires to be piped to blacksmiths and others using it regularly. These connections should be placed on the shop walls, two connections to each wall, for general requirements. Drinking

is a machine of local design and consists of two sets of 12 in. x 16 in. cylinders mounted, one pair on a horizontal plane and the other pair on a vertical plane. The cylinders are connected in pairs so that one valve operates the two horizontal cylinders and one valve the vertical ones. The outer ends of the pistons are connected by a suitably shaped heavy cast iron die which presses the hot bent or twisted beam back to its normal shape. The top die is shaped with a high reinforced arch in the center, so that the coupling which is sometimes riveted to the bar is not interfered with as the top die descends. The ends of these dies are just short of the shoes on the beam ends so that the shoes remain undamaged during the operation. The machine is air operated and mounted on a stout structural steel frame. A little manipulation of these cylinders soon enables an experienced operator to remove almost any sort of a kink. Occasionally a beam is bent so that it cannot be inserted in the machine at all; it is then first placed on the leveling plate and roughly straightened with a few hammer blows. After leaving the straightener the beam is placed on the leveling plate, and if the least set is required to bring the shoes in line, this is done with a hammer; the beam is then placed in a cooling bath of water and quenched. This cooling gives a mild temper to the beam and the tests we have made show that a slight increase in rigidity over a new beam results. Fulcrum brackets, etc., are now riveted in place. After dipping in a paint bath the beam is ready for removal from the shop. No mention has been made of the punch used in this con-



nection, but quite frequently beams have to be handled that have no safety clips or for some other reason holes are required in the web of the beam. This punch performs all these operations, and will also do the riveting when the dies are changed. A drilling machine is sometimes used for this work, but we find a considerable saving by using the punch. It will be noticed that the beams follow a regular cycle and end at a point where the laborers, who have just dumped a load of old beams, can pick up a load of new beams and remove them from the shop.

It is advisable to place the blacksmith forges as close to the brake beam repairing outfit as possible in order that the blast pressure may not be lowered by long travel through the pipes. Blacksmith forges have been placed at a distance of 12 ft. apart along the outer wall, the backs of the forges being placed so that the light from the windows is not interfered with any more than can be avoided. The space opposite the fires is left for material storage, and part of this blank space could be used when space is required for any special purpose which may develop. At the end of the row of forges is placed an oil furnace for welding truss rods, brake rods, etc., and opposite the furnace is placed a power hammer. This method of placing the hammer directly in front of the furnace is better than the older method of placing the hammer at the side for the reason that both men stand in front of the furnace and each takes one end to be welded from the furnace and both make a single half-turn, after which they are both in position for welding at the hammer. By reason of the success of this method we have changed the position of all similarly operated machines around the different shops. As it is very possible that this work may grow in such proportion as to demand a double unit, space has been left to accommodate it. In order that this outfit may not be hampered by movement of shop trucks, the industrial track has been shifted along this section of the shop close to the main shop wall.

Next to the welding furnace is placed the threading machines, which have a capacity for all sizes up to 2½ in. diameter. These machines will take care of all work handled in the shop and also all rods handled by the blacksmiths. The first machine will handle all the shorter bolts while the second will thread all long rods, space being left to accommodate long rods, like truss rods.

Drilling machines are placed next; these are single spindle machines with tables 30 in. in diameter. These machines need plenty of light and are placed in front of the windows. A multiple spindle drill is very handy, but not an absolute necessity at the beginning.

For general use, the pneumatic punch or riveter is very useful. The double floor grinders for tool and general grinding, and a lathe practically completes the equipment of the machine department on this side. In the corner are benches for use of pipefitters, millwrights and other departments not requiring special machinery. The dope press is, as its name implies, simply an air operated cylinder, the outside piston of which presses down into a chamber filled with old and useless dope. While the dope cannot be used again the oil, after straining, is quite good. The oil is squeezed through small holes in the bottom plate and runs to a pan.

Another special unit is the oil reclaiming plant, which is also of local design. This outfit consists of two tanks in which are steam heating coils. Dope is placed in one tank just as it is removed from the cars, and subjected to heat, which, with the aid of a pump, draws off most of the oil. The comparatively dry dope can then be cleaned more readily. After cleaning it is oiled and placed in the second tank ready for use again. This outfit has been the means of greatly reducing the oil expense.

Passing to the main shop, the machinery is seen to be somewhat scarce, as it should be, all available space being required for car repairs. The only available space is between the shop columns. At two points in the shop is a single drill and a double floor grinder—the drill is to take care of all odd jobs

which occur regularly in the day's run, so that delay is avoided in traveling to the machine department, and the grinding wheels are graded for rough grinding of all kinds. These two machines can be driven by a single motor on the shop column with a single countershaft. Another small machine is a short rivet shear. It happens often that special lengths of rivets are required and these have to be cut from larger rivets. This seemingly small item caused much lost time and a small shear was designed especially for this purpose.

Vises attached to every third column are a good substitute for the usual clumsy bench and are out of the way when so attached.

As a means of making the shop as independent as possible an electric tractor, placed at one end of shop, enables cars to be pulled in and out of the shop. By a system of snatch blocks any track can be drawn and filled again with very little trouble.

The steel car straightening frame erected in the Winnipeg shop is similar in pattern to the type erected at different points on the Canadian Pacific and consists of a heavy structural steel housing into which steel cars, having received a side swipe or other wreck damage to the body or underframing, can be placed and jacked back into correct alignment. Each column of this housing is made up of two 12 in. channels reinforced by two 6 in. I-beams, and long screw jacks slide between the channels to the point of application of pressure; between these columns horizontal beams are adjusted so that pressure may be applied from any point on both sides of the car in a horizontal plane. Portable oil burners are used to heat any part of the car in particular and then the pressure from the jack straightens the frame to its original form. Large rings are set in the concrete base and thus by aid of chains and jacks, upward or downward pressure is applied. For a shop of the size shown in the general plan, this straightener should accommodate at least two cars at one time.

On the other side of the shop a new department in car shops is observed. This department resembles a miniature boiler shop and it has all the appliances required to handle structural steel. The large machine is a structural steel straightening roll. The necessity of this machine has become more apparent of late, and we are at present engaged in completing its design. As in the case of brake beams, it will be found to be more economical to remove bent members from a car and to replace them from a stock of straightened members. These bent members can then be placed in a pile and brought into the shop and straightened and returned. If climatic conditions will allow, this machine should be placed outside. The machine has two sets of rolls; one set will accommodate all sizes of Z bars and angles while the other is designed entirely for channels of different sizes. The machine will be high powered with instantaneous reverse mechanism. Extending both front and back of the machine will be long tables with rollers inset so that as the straightening proceeds the bars will run on the guides. Trap doors will be required in the end of the shop so that the straightened long beams can be run right out of the shop without further handling.

Additional equipment in this department will consist of a power punch and shear large enough to cut and punch all structural shapes and also the steel siding. A small hand roll for steel sheeting and a small furnace for heating roof members and other shorter members is required, and possibly also a clamp.

At the other end there is the section devoted to wood workers. This space, while large enough for all wood workers required for car siding and flooring, will ultimately, it may be expected, be superseded by the workers on steel car sides. However, as most of the wood is received prepared from the mill the machinery layed out, viz., two saws and one boring machine, will take care of all required machine work

until that time. Painters and air brake men can also be located in this section. Depending entirely on the location of the steel car shop the steel cars might be removed from the shop as soon as the steel work is completed, and then transferred to the freight shop, where all wood could be applied. This would be a better arrangement in a case where the steel car shop adjoins or almost adjoins the wood freight shop. In such cases the space allotted to wood workers could be occupied by steel plate machine workers.

*Operation of the Shop.*—The organization of a steel car shop must be made to conform to the local conditions. Local conditions affecting the shop organization are those concerning the class of labor employed and the degree of intelligence obtainable in the men. The duties of all men must be clearly defined and duties must be such as to be easily understood. Steel car repairers are, in some shops, mostly foreigners. It is obvious that we shall meet with little success if we display written instructions regarding repairs to these men if they cannot read them, and yet it is obvious we must instruct them in some way. As illustrative of a typical organization, with possibly the most variable of conditions to be met in workmen, the local conditions at Winnipeg might be cited. Our car repairers are mostly foreigners and are a sort of graduated laborers. These men are of average intelligence and require very little instruction once they get acquainted with the work, but the demand for unskilled labor has been such that no sooner does a man get useful at his work and learns to speak a little English, than he quits and finds something more remunerative. The laborers are changing all the time and efforts to train laborers to obtain material fail, because they do not stay long enough to learn. The high rates of pay for outside unskilled work in this district is responsible to a large extent for this condition.

The whole shop is directed by the shop foreman and he has assistants in the shop. The number of assistants depends on the number of cars per month, but for a shop with six cars to a track, one assistant can handle two tracks. A report of the repairs always reaches the shop in advance of the car and this should give sufficient information to enable the foreman to line up all special material. As soon as the cars are placed in the shop, the assistant foreman carefully inspects each car and marks on the board provided for each car what material is required to be brought in the shop. Certain men in gangs of one car repairer and one laborer are assigned to the cars for the repair work and instructions are given by the assistant foreman. Small tools and appliances are procured by the car repairer from the storeroom, while bolts and other small material are obtained from the stores by the laborer on the foreman's written order. Larger material, that is stocked outside the shop, is brought to the car on the foreman's order by the shop material gang. This gang is composed of laborers headed by a charge hand who speaks English as well as other languages. This man reports to the shop foreman, but takes instructions from all the assistant foremen and delivers material as required. This man is also responsible for the cleanliness of the shop. Thus it is seen that a car repairer has no business whatsoever outside the shop, unless under orders from his foreman.

Painters come directly under the shop foreman and are directed as required around the shop. The "Paint Gun," as it is termed, is a source of economy if used discreetly. On steel car work it is found to be a saving on intricate parts such as trucks, corners of steel structural work, etc., but for flat surfaces the brush painter is better.

All other help in the shop is also controlled by the shop foreman. An assistant foreman desiring preference on certain work must consult the general shop foreman. The organization must always be that each man is responsible to one immediate superior.

The space around the shop outside should be divided up to

accommodate a stock of all standard parts and the assistant foreman and gang charge hand should immediately notify the shop foreman when the minimum stock is being reached in any particular. The shop foreman will then order a new stock, so that delay shall not occur from this source. Material delays are the general source of trouble, so that special care must always be taken, particularly in the case of foreign material, that orders are placed as far in advance as possible.

## REFRIGERATOR CAR DESIGN

There are differences of opinion regarding the most desirable weights of cars, kinds of insulation, types of icing arrangements, etc., but all experts are agreed that refrigerator cars must be very carefully designed, very well built and very carefully maintained. A refrigerator car is a cold storage plant on wheels, but its service is such that what might be entirely practical for an ordinary cold storage plant may not be practical in a refrigerator car. Likewise the general type of box car construction cannot be followed in all its details in the construction of the refrigerator car. A refrigerator car is heavier than a box car of the same general proportions and capacity because of the added weight of the insulation; and this should be considered in designing the trucks to be used under refrigerator cars. A refrigerator car built to the general design of a box car of a given capacity may never be loaded to the limit of this capacity with perishable freight, the extra weight of the insulation and ice being considered. But trouble comes when such a car is used in other than refrigerator service; for then it is very apt to be overloaded. For this reason some roads have rated their refrigerator cars below the rated capacity of the trucks.

The extra weight of the refrigerator cars is wholly carried in the superstructure, which, together with the high or suspended loads usually carried, will raise the center of gravity of the car an appreciable amount. This has at one time or another caused a large number of derailments, but has been overcome almost entirely by decreasing the distance between the side bearings, having them come well inside of the rails. The standard practice in this regard seems to be 48 in., or 2 ft. each side of the center of the truck, with a clearance of  $\frac{1}{4}$  in. to  $\frac{3}{8}$  in. Some car designers are strongly in favor of roller side bearings or some anti-friction arrangement that will assist the trucks in traversing curves, as the refrigerator car bodies are of such rigid construction that they will not ease off from the side of the truck as it strikes the elevated outer rail of a curve.

A difficulty that has been experienced by many roads is that of keeping refrigerator cars clean and free from permeating odors. One car company has had very good success in this regard by applying two coats of hot linseed oil to the inside sheathing of the car and covering this with a good grade of varnish. The oil will be absorbed as soon as applied, closing the pores of the wood, and thereby preventing any material amount of absorption of any odors. In addition to this the cars are kept clean with ordinary soap and water.

One of the secrets of success in refrigerator car construction is the building of a car that will withstand all the shocks and torsional strains that may be given to a car in service, without opening cracks in the superstructure that will in any way interfere with the insulating properties of the car. To attain this requires the best possible workmanship, together with a high grade of material. At the same time if the cars are not properly maintained their efficiency will be greatly reduced and the beneficial effects of up-to-date and scientific construction destroyed. Refrigerator cars are built with the definite purpose of protecting in transportation perishable products, the damage claims on account of which, if they are not properly protected, may cost the carrier more than is received in revenue. Therefore, cheapness of construction in such cars may be, and usually is, a most extravagant economy.—*Railway Age Gazette*.



# BRAKE PERFORMANCE ON PASSENGER TRAINS

Discussion of Tests Which Were Made on the Pennsylvania Railroad and Discussed by the A. S. M. E.\*

BY S. W. DUDLEY  
Assistant Chief Engineer, Westinghouse Air Brake Company

Realizing the significance of the knowledge and experience accumulated in recent years, the Pennsylvania Railroad, in conjunction with the Westinghouse Air Brake Company, instituted, in the spring of 1913, the most scientific and comprehensive investigation of the different factors affecting the operation of brakes on steam railroad passenger trains that has been undertaken since the Galton-Westinghouse trials of 1878 and 1879. In addition to an examination of the characteristics of brake shoe friction throughout a wide range of laboratory and operating conditions, the test included also a study of the effect of various

when required on the one hand, and preventing it, when not required on the other.

In considering the improvements desirable in the above particulars four factors require special attention:

A The characteristics of the mechanism available for controlling the pressure of the compressed air in the brake cylinders.

B The efficiency of the mechanical transmission of the force of compressed air developed in the brake cylinders, through the rods and levers of the brake rigging to the brake shoes.

C The efficiency of the brake shoe in transforming the pres-

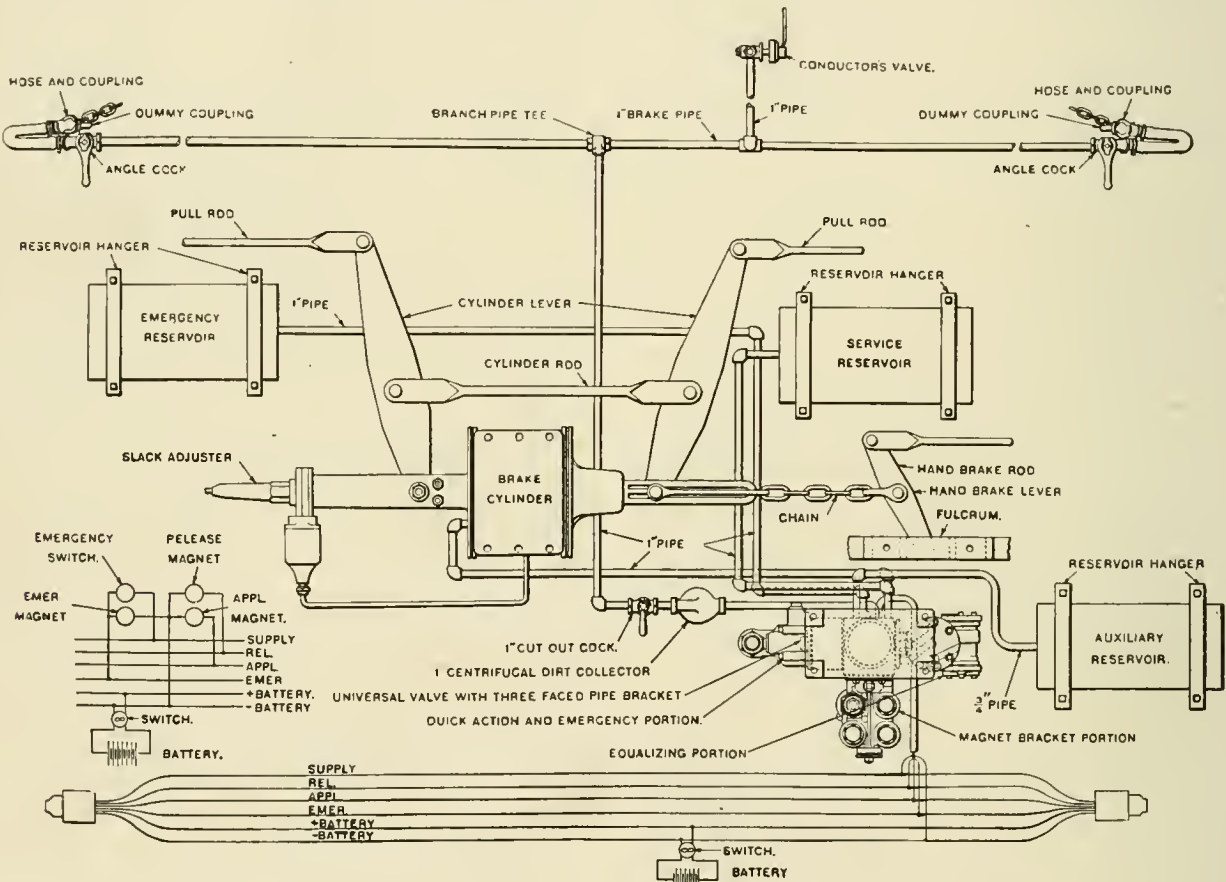

Diagram of the Complete Westinghouse Electro-Pneumatic Brake (U C Equipment)

types of air brake mechanisms and foundation brake rigging and different degrees of emergency braking force.

The tests indicated the degree to which existing apparatus was suited to existing conditions, the direction in which improvement was necessary and could be made, and the amount of improvement actually accomplished.

The limitations of the old brake apparatus are most marked in the following particulars: In the length of emergency stops; the uniformity of brake applications on different vehicles comprising the train; the safety and protective features demanded by service conditions of great severity and complexity; the flexibility and certainty in applying and releasing the brake during service application; and the increased difficulty of keeping the action and emergency functions separate, i. e., insuring quick action

\*Sections of the complete paper have been eliminated in this article.

sure imposed on it into retarding force at the rim of the wheel.

D The available adhesion between the car wheels and the rails.

There are four factors which have a controlling influence on the length of stop: (1) the maximum brake cylinder force; (2) the time in which this is obtained; (3) the efficiency of the foundation brake rigging in multiplying and transmitting this force to the brake shoe; (4) the mean coefficient of brake shoe friction.

All but the last factor can be controlled or properly provided for in advance by correct design and installation. On the other hand the experience of recent years has repeatedly demonstrated that no one of these four factors can be neglected without a corresponding loss in effective retarding force. It is therefore of the greatest importance to distinguish and give due consid-

eration to the controllable factors mentioned in order to compensate as far as possible for the unavoidable variations in brake shoe friction. That these variations have more than a merely nominal effect follows from the fact that the brake shoe, considered as an element of the mechanical system transforming the force of compressed air into retarding force at the rim of the wheels, is low in efficiency, averaging for stops from 60 m. p. h. in the neighborhood of 10 per cent. Consequently a slight variation in brake shoe performance can cause a considerable percentage of change in mean coefficient of brake shoe friction and a corresponding change in length of the stop, the latter being subject to a range of variation of as much as 20 per cent, or more *due to brake shoe condition alone.*

The object of the Pennsylvania Railroad tests of 1913 was to make as thorough a study as might be found practicable of the variables mentioned above and their effects, with particular reference to:

- A A determination of the maximum percentage of emergency braking power which can be adopted, considering:
  - a The type of brake shoe to be used.
  - b The type of brake rigging to be adopted.
  - c The type of air brake mechanism and control to be adopted.
  - d The degree to which occasional wheel sliding is to be permitted under unfavorable circumstances.
  - e The variation in the condition of the rail surface for which it is considered necessary to provide.
- B A comparison of the relative performance of the clasp

sible the characteristics of this type of brake shoe under the influence of various combinations of speed, pressure, time, weather and the conditions of the brake shoe.

E The coefficient of friction between the wheel and the rail under varying weather conditions.

In addition to the investigations outlined in general above, it developed during the tests that additional data were desired regarding the performance of brake shoes under certain specific conditions. In consequence a series of experiments was carried out at the laboratory of the American Brake Shoe and Foundry Company, at Mahwah, N. J.

FEATURES OF EQUIPMENT AND APPARATUS TESTED

The tests of the standard (type PM) air brake equipment were planned to determine the characteristic performance of this type of equipment throughout the range of service and emergency operating conditions typical of the ordinary service in which this equipment is in general use in order to bring out its limitations and serve as a standard of reference to measure the betterment made possible by the improved features of the new air brake apparatus, the more efficient design of foundation brake rigging and more satisfactory brake shoe performance.

The special features of the improved air brake equipment (type UC) which received more or less attention during the tests may be summarized as follows:

- A The electro-pneumatic brake equipment is adapted to meet any requirement, from that exemplified in the PM brake equipment to the more exacting requirements of present conditions,

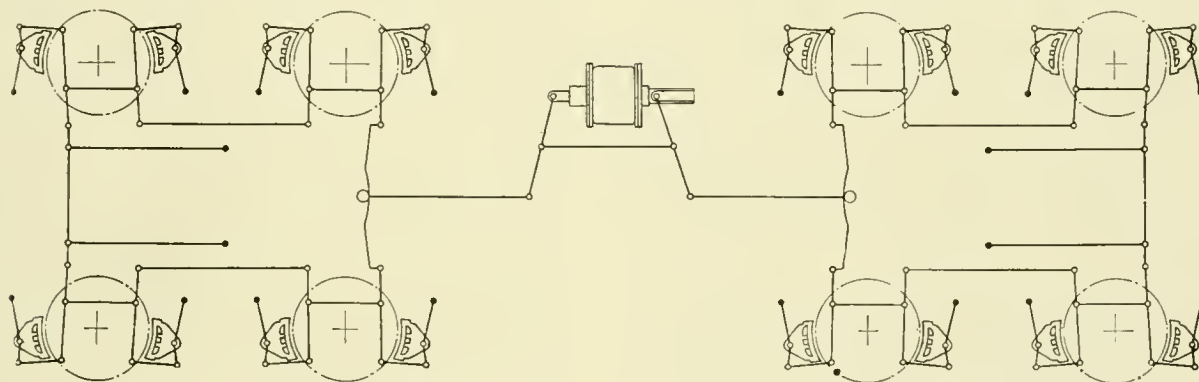

Outline Diagram of Lever Arrangement on No. 3 Clasp Brake Rigging

brake rigging (two shoes per wheel) and the standard brake rigging (one shoe per wheel) with regard to:

- a Maintenance of predetermined and desired piston travel.
- b Efficiency of transmission of forces.
- c Effect upon wheel journals, bearings and truck.
- d Mean coefficient of brake shoe friction for the standard plain cast iron shoe.
- C A comparison of the performance of the improved air brake mechanism (type UC) with that of the commonly used "high speed" (type PM) brake equipment with regard to:
  - a Efficiency and effectiveness, as shown by the length of service and emergency stops.
  - b Safety and protective features.
  - c Flexibility and certainty of response to any manipulation of the engineer's brake valve.
  - d Uniformity of action of individual equipments associated in the same train and of any individual equipment at different times.
  - e Smoothness of riding during stopping, slack action between cars, and the resulting shocks.
  - f Capacity for future requirements.

D The behavior of the brake shoes as the tests progressed and any variation in the results of similar tests which could not be accounted for by known changes independent of the brake shoe. One type of brake shoe was to be used throughout the range of the tests. Relating to objects A, B and C, advantage was taken of this opportunity to establish as definitely as pos-

sible the characteristics of this type of brake shoe under the influence of various combinations of speed, pressure, time, weather and the conditions of the brake shoe.

B Considering cylinder pressure alone the equipment may be installed so as to produce any desired pressure, either in service or in emergency.

C The gain by use of the electric control, in addition to the pneumatic, is the elimination of the time required for the pneumatic transmission of the action of the brake from car to car and, in addition the elimination of shocks and uncomfortable surging which results from the non-simultaneous application of the brakes on all cars.

It is apparent that the gain from the electro-pneumatic control is not so much in the shortening of the stop, particularly in emergency, as it is in the increased flexibility and certainty of control of the brake and the assurance that modern long heavy trains can be handled smoothly and accurately.

D The troubles and inconveniences due to brakes failing to release, as well as the undesired application of brakes due to unavoidable fluctuations of brake pipe pressure when running over the road, are eliminated.

E An adequate supply of air is available at all times.  
 F The emergency braking power is available at any time, even after a full service application of the brake, since it is impossible for the engineman to use up the reserve emergency pressure without making an emergency application.

G The equipment is adaptable to all weights of cars and



to any desired percentage of braking power. Two brake equipments for heavy cars are not necessary nor are two service brake cylinders required, except for cars weighing more than the limit of the service capacity of one brake cylinder. Provision is made for using one brake cylinder up to the maximum percentage of emergency braking power which it can provide, and for using two cylinders when a higher emergency braking power is desired. When using one brake cylinder, the maximum service pressure is controlled by means of a safety valve. When two cylinders are used, equalizing pressure from 110 lb. brake pipe pressure is utilized for the service brake (instead of blowing the air away at a reducing valve) and another brake cylinder is used for the additional power required in emergency applications. The use of one or two cylinders is optional, depending upon the amount of braking power to be employed.

Duplicate tests were made with the clasp brake rigging, two shoes per wheel, for every test made with the standard brake rigging, one shoe per wheel, in order to bring out the advantages of the clasp brake in the following desirable features: (A) constant piston travel for all cylinder pressures; (B) smoothness of action during stopping; (C) greater certainty of obtaining and maintaining the predetermined braking force contemplated in the design of the air brake equipment and foundation brake rigging; (D) less displacement of journals, bearings and trucks, tending toward greater mechanical efficiency and less cost of maintenance; (E) a coefficient of friction equal to or greater than that with the single shoe brake with less wear of brake shoe metal and lower wheel and brake shoe temperatures.

The original plan contemplated two 12-car trains of standard P-70 steel passenger cars. These cars have 4-wheel trucks with one 16-in. brake cylinder per car. One train was equipped with the clasp type of brake rigging (two shoes per wheel) and the other with the type of standard brake rigging (one brake shoe per wheel) existing on these cars since they were

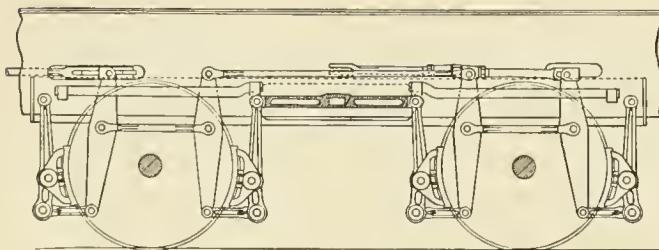
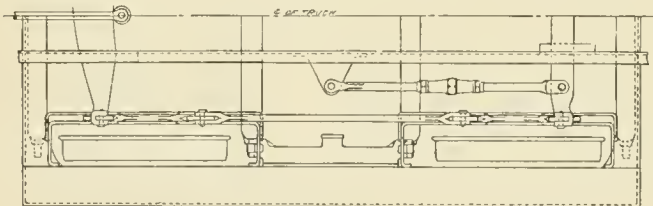

Brake Rigging Referred to as No. 3 Clasp Brake

built, but modified by increasing the strength of the members to be suitable for 180 per cent braking power which necessitated lowering the brake shoes  $1\frac{1}{8}$  in. below their former position and by anchoring the truck dead lever to the car body, instead of to the truck.

In order to obtain the best data possible, instruments were devised for taking records of the friction of the rail, wheel sliding, retardation of the train, and slack action between cars as well as for a number of minor observations.

The test train was 1,040 ft. long, consisting of a Pacific type locomotive and tender of the P. R. R. K2s class, weighing, in working order, about 200 tons, and 12 passenger cars averaging about 61 tons each.

The ET air brake equipment was used without any modification on the locomotive, except that in some tests an auxiliary device was used which increased the braking power obtained during the early portion of the stop.

The cars were equipped with the present standard air brake apparatus (PM) and with the improved type of air brake equipment (UC), these installations being so arranged that a complete change from the standard equipment (PM) to the new equipment (UC) having PM features only or the complete pneumatic features of the new equipment or to the new equipment with complete electrical control could be quickly made.

The standard plain cast-iron brake shoe was used in most

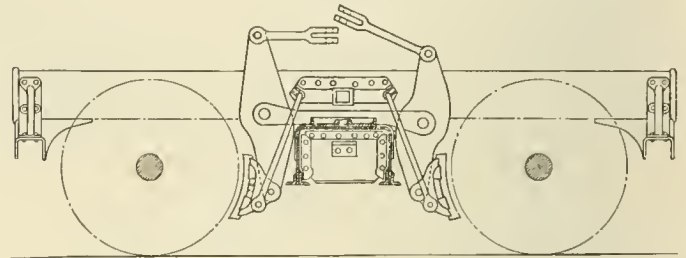

Brake Rigging with One Shoe to Each Wheel

of the tests. In several tests flanged, slotted and half area shoes were employed. Special care was taken to insure uniformity in quality and the condition of all shoes at the beginning and during the progress of the tests.

The high-speed reducing valves of the PM equipment were adjusted to open at 62 lb. brake cylinder pressure.

The standing piston travel was adjusted before each run to  $6\frac{1}{2}$  in. with a full service brake application.

The tests were made on the southbound track of the Atlantic City Division of the W. J. & S. R. R. The portion of the track over which the braking was done was level, and part of a tangent about 25 miles long terminating at Absecon Station. A slight descending (0.3 per cent) grade approaching the measured test track was in favor of the train attaining speed. The point at which the brakes were applied was 2,880 ft. north of mile post 9.

The track for a distance of 5,000 ft. south of the zero point was wired for circuit breakers, which were placed at intervals of 25 ft. up to 1,200 ft. from the zero point, and at intervals of 50 ft. from there on to the 5,000 ft. point. Preceding the zero point, eight circuit breakers were located, 66 ft. apart from which the initial speed of train (speed at the trip) was determined.

A cabin, located near the zero circuit breaker, contained the clock and chronograph from which in connection with the track circuit breakers, the speed of the train before and during the stop was obtained.

After each test measurements were taken of the total length of the stop, and also the running piston travel on each car.

Of the devices used on the track, the only one which requires special mention is the machine that was used to measure the force required to move or keep moving a block of tire steel resting upon the rail. The pressure of this block on the rail could be varied by means of weights of 20, 40, 60, 80 and 100 lb. Readings were taken with each of these weights and the coefficient of rail friction recorded was derived from the average of the five readings.

#### FEATURES OF THE UC EQUIPMENT

The manner in which the functions of the universal control equipment are performed is described in full in the report of the tests. The valve mechanism which is the distinguishing feature of this equipment is of the "built-up" type which makes it possible to install and operate this equipment if desired in stages, by adding to the simplest arrangement of apparatus, including only those features required to give an operation

equivalent to that of the PM brake, up to the complete form of the device.

The UC equipment, in its complete form comprises a valve mechanism called the *universal valve* with its permanent pipe bracket and three reservoirs, the auxiliary, the service and emergency reservoirs.

The universal valve consists of an equalizing portion, which primarily controls the charging and recharging of the reservoirs of the equipment, the service application of the brakes and the releasing of the brakes.

A quick action portion with high pressure cap, which controls the transmission of serial quick action and obtaining of high emergency pressure in the brake cylinders when an emergency application of the brakes is made.

An electric portion, which comprises the magnets, switch, etc., controlling the electric service application, electric release and electric emergency applications of the brakes.

A pipe bracket, to which all pipe connections are permanently made and to which the various portions of the valve device are bolted. This bracket contains two small chambers, the quick action chamber and quick action closing chamber.

The quick action closing chamber provides means whereby the quick action outlet from the brake pipe to the atmosphere is open when an emergency application is made and is closed when a predetermined time thereafter has elapsed.

The quick action chamber in connection with the quick action closing chamber controls the operation of the quick action parts of the valve in accordance with the rate of brake pipe reduction.

In addition to the above the equipment on each car comprises:

An auxiliary reservoir which is the same size for all sizes of brake cylinders, the pressure in which controls the movement of the equalizing piston and slide valve of the universal valve and supplies air to the brake cylinder.

A service reservoir which varies in size with the size of the brake cylinder. This, together with the auxiliary reservoir, supplies air for operating the brake cylinder in service and emergency brake applications.

An emergency reservoir which varies in size according to the size of brake cylinder used and the amount of emergency brake cylinder pressure which the installation is designed to afford. This reservoir supplies the air required to graduate the release of the brakes and to obtain quick recharging of the service and auxiliary reservoirs after a service application of the brakes. It also provides the additional supply of air required to obtain the increased brake cylinder pressure desired for emergency applications.

The valve mechanism is designed to require a drop in brake pipe pressure of approximately 4 lb. before it is possible to obtain an application of the brakes. The equalizing piston moves on a differential much lower than this, however, so as to close the feed groove and thus prevent back leakage from the auxiliary reservoir. Thus a service application of the brakes is positively insured when the required 4 lb. brake pipe reduction is reached. From this point the rise in brake cylinder pressure corresponds to the reduction in brake pipe pressure in the proper relation to produce a full service brake application (90 per cent. braking power) for a brake pipe reduction of 24 lb.

#### GENERAL DISCUSSION OF STOPS

By reason of the many combinations of conditions under which different tests were run, including different types of air brake equipments, methods of applying the brakes, nominal per cent of braking power, types of brake rigging, brake shoe conditions, speeds and train make-up, a great variety of general comparisons might be made to illustrate the effect of these various conditions singly or in combination on the length of stop and the behavior of the trains during stopping. It will be possible to point out in this paper only the more significant and important comparisons which emphasize the salient features of the tests.

The shortest 60 m. p. h. emergency stop was made with a single car (locomotive not attached) with the No. 3 clasp brake electro-pneumatic equipment, 180 per cent braking power, and flanged brake shoes. The car was stopped under these conditions in 725 ft. The average retarding force for this test was 332 lb. per ton. This is equivalent to the resistance offered by a 16.6 per cent grade on which one end of a P-70 car (80 ft. long) would be 13.3 ft. higher than the other end.

This stop of 725 ft. from 60 m. p. h. made with a modern heavy passenger equipment car establishes a new record for a railway car stop.

Assuming a rail adhesion of 25 per cent, the shortest possible stop which could be obtained, by utilizing this adhesion to its maximum throughout the period of braking, would be 481 ft. This would require an ideal brake shoe and a controlling mechanism which would automatically adjust the retarding force of the brake, so that it would be at all times the maximum which could be used just short of producing wheel sliding.

The shortest 80 m. p. h. stop was made, with conditions the same as mentioned above, in 1,422 ft. This is equivalent to an average retarding force of 310 lb. per ton.

From the data of stops made with locomotive alone and single car breakaway stops it is possible to calculate the approximate length of stop which would be obtained with a locomotive and train of twelve cars equipped with the electro-pneumatic brake.

Calculated from the results of single car breakaway tests, the best 60 m. p. h. train stop that could have been obtained with the means available during these tests is about 800 ft. and the best 80 m. p. h. stop about 1,570 ft.

The shortest 60 m. p. h. train stop with a locomotive and train of twelve cars was 1,021 ft. This was made with high braking power on the locomotive and No. 1 clasp brake, electro-pneumatic equipment, 180 per cent braking power and plain shoes on the cars.

The shortest 80 m. p. h. train stop was made in 2,197 ft. with high braking power on the locomotive and with No. 1 clasp brake, electro-pneumatic equipment, 150 per cent braking power and plain shoes.

#### BRAKE SHOES

The condition of the material in the brake shoes, the manner in which they are adjusted to fit the wheel, and the bearing which the shoes have on the wheel will materially influence the length of stop, having the greatest effect at the higher speeds. These agencies, although previously observed and recognized in a theoretical way, had never been so forcibly impressed upon observers as during the present series of tests and the information gained from the performance of the brake shoes in the tests has developed some noteworthy facts in regard to them.

#### CONCLUSIONS

In service applications with the improved (UC) equipment a greater flexibility of operation is provided. That is, the braking power per pound of brake pipe reduction is lower, thus giving the engineer a greater time in which to use judgment when manipulating the brakes. At the same time, however, the maximum braking power obtainable in a full service application is higher.

A more sensitive and prompt release of the brakes is insured, tending to improve the releasing action of all brakes in the same train of mixed old and new equipments.

The action of the old and the new equipments mixed in the same train is harmonious and free from rough slack action or shocks both in service and emergency operation.

The UC equipment is adaptable to any weight of car and may be installed to furnish any desired nominal per cent of braking power.

With the new equipment operating electrically or pneumatically, there is always available a quick acting and fully effective emergency brake. This is not the case with the old equipment, in which the relation of the service and emergency functions



is such that a quick action application could not be obtained after a service application of any consequence. The following average results indicate the degree to which this difference has an effect on the length of stop. Considering the ordinary full service stop from 60 miles per hour with both brakes (say 2,000 or 2,200 ft.) as 100 per cent, the attempt to make an emergency application with the old equipment does not produce any shorter stop than if only a full service application were made. With the improved apparatus operating pneumatically, an emergency application following a partial service application will shorten the stop about 14 per cent and after a full service application about 10 per cent.

With the electro-pneumatic brake these figures are respectively 23 per cent and 15 per cent.

An electrically controlled brake application has been recognized as ideal ever since the report to this effect presented by the Master Car Builders' Committee in charge of the famous Burlington Freight Brake Trials 1886 and 1887, for the reason that thereby the time element in starting the application of the brakes on various cars in the train is eliminated, a correspondingly shorter stop made, and the possibility of shocks at any speeds removed. With the new brake apparatus the effectiveness of the pneumatic emergency application is so considerably increased that the saving in time due to electric control has proportionately less influence on the length of stop, but its effect in eliminating serial action and consequently the possibility of shocks due to brake application is of importance.

The graduated release feature of the improved brake apparatus permits stops to be made shorter, smoother and with a greater economy in time and compressed air consumption.

The new apparatus can be applied to give only the equivalent of the old standard apparatus if desired but in such a form the complete new apparatus can then be built up by the addition of unit portions to the simplest form of the mechanism.

The electro-pneumatic brake acts as an automatic telltale in cases of malicious or accidental closing of an angle cock after the train is charged by permitting all the brakes to apply, it being thereafter impossible to release the brakes behind the closed cock until the cock is opened.

The PM equipment will start to apply on a brake pipe reduction of 2 lb. A 4-lb. brake pipe reduction is required to start an application with the UC equipment, thereby preventing undue sensitiveness to application on slight, unavoidable fluctuations in brake pipe pressure. As a bona fide service reduction of more than 4 lb. continues, the rate of attainment of braking power is the same as if no stability feature had existed.

The attainment of full service braking power on the entire train with the UC equipment operating pneumatically was 16 seconds, 33 per cent longer than with the PM equipment because of the smaller size reservoirs used for greater flexibility.

Full service braking power was obtained in nine seconds with the electro-pneumatic power, but without sacrificing desirable flexibility because of the increased sensitiveness of control.

The time of transmission of serial quick action through the brake pipe is practically the same with UC and PM equipments.

The time to obtain full emergency braking power with the PM equipment on the entire train was 8 seconds; with the UC equipment operating pneumatically 3.5 seconds or 56 per cent shorter; with the electro-pneumatic equipment 2.25 seconds or 72 per cent shorter.

With the electro-pneumatic brake a uniform increase in per cent of braking power results in a substantially uniform decrease in length of train stop. An increase of 5 per cent in braking power reduces the length of stop about 2 per cent within the range of braking powers tested.

The available rail adhesion varies through wide limits, e. g., from 15 per cent in the case of a frosty rail early in the morning to 30 per cent for a clean, dry rail at mid-day.

The amount of wheel sliding depends more on the rail and weather conditions than on the per cent braking power. Some

sliding was experienced with braking powers as low as 90 per cent and 113 per cent where rail conditions were unfavorable, but 180 per cent braking power did not cause wheel sliding with good rail conditions.

The effect of excessive wheel sliding was to make the length of the stop about 12 per cent greater than similar stops without wheel sliding.

*Brake Rigging.*—An efficient design of brake rigging must be produced before the advantages of improved air brakes or brake shoes can be fully utilized.

The use of the clasp type of brake rigging eliminates unbalanced braking forces on the wheels and so avoids the undesirable and troublesome journal and truck reactions that come from the use of heavy braking pressures on but one side of the wheel. This has an important effect not only on freedom from journal troubles but also in enabling the wheel to follow freely vertical inequalities of the track.

The clasp brake also improves the brake shoe condition materially, both as to wear and variability of performance.

Although the clasp brake rigging will produce better stops than a single shoe brake rigging equally well designed (other conditions being equal), its advantage in this direction is of less importance than in the improved truck, journal and shoe conditions mentioned above.

The tests indicated that at least 85 per cent transmission efficiency could be obtained with either single shoe or clasp brake rigging.

The following features were observed to be of importance if maximum overall brake rigging efficiency is to be secured:

(a) Protection against accidents that may result from parts of rigging dropping on the track.

(b) Maximum efficiency of brake rigging at all times to insure the desired stopping with a minimum per cent of braking power.

(c) Uniform distribution of brake force, in relation to weight braked, on all wheels.

(d) With a given nominal per cent braking power, the actual braking power to remain constant throughout the life of the brake shoes and wheels.

(e) Piston travel to be as near constant as practicable under all conditions of cylinder pressure.

(f) Minimum expense of maintenance and running repairs of brake rigging between the stopping of cars.

*Length of Stop.*—The stops and observed performance of the air brake, brake rigging and brake shoe are in agreement with the relation generally assumed to exist between the speed and other variables mentioned and resultant length of stop. This relation for straight, level track and neglecting air and internal friction on the one hand and the rotative energy of the wheels and axles on the other hand, is:

$$St = 1.467Vt + \frac{V^2}{30Pef}$$

in which the terms have the following significance and range of values according to conditions

$St$  = length of stop to be expected in ft.

$V$  = initial speed of train in m. p. h.

$t$  = time at the beginning of the stop during which the brakes are to be considered as having no effect, to allow for the time element in the application of the brakes.

		Kind of Air Brake Equipment	
		PM	UC Electro-Pneumatic
For a 12-car train	from	2.0	0.70
	to	2.5	0.85

$P$  = nominal per cent braking power corresponding to the average cylinder pressure existing for that portion of the stop after the brake is considered fully applied.

With a single car or several similar cars, stopping without the locomotive attached, the value of  $P$  can be obtained from an average of all brake cylinder indicator cards or taken from one typical brake cylinder card, provided all cylinder pressures and foundation brake installations are substantially alike.

# SHOP PRACTICE

## REPAIRING SLIDE VALVE FEED VALVES

BY J. A. JESSON

Air Brake Foreman, Louisville & Nashville, Corbin, Ky.

The successful working of the feed valve depends principally on the fit of the piston and supply valve. It is essential that the cylinder and valve bushings be in alinement and that the fit of the piston in its cylinder be accurate.

The drawings show a method developed by the writer for

in the end of the mill. An end mill *D* is used for facing off any irregularities on the end of the body to which the cap nut fits. This mill has a 1-in. hole and should be operated on the pilot shown in Fig. 2, being shown in Fig. 4 as a matter of convenience. It is turned by a handle which fits in the key way as shown and is fed by the nut *C*.

A jig for truing up the feed valve piston is shown in Fig. 5, in which *A* is a steel cylinder; *B* is a similar piece which fits closely in *A*; *G* is a split bushing and is used for holding the

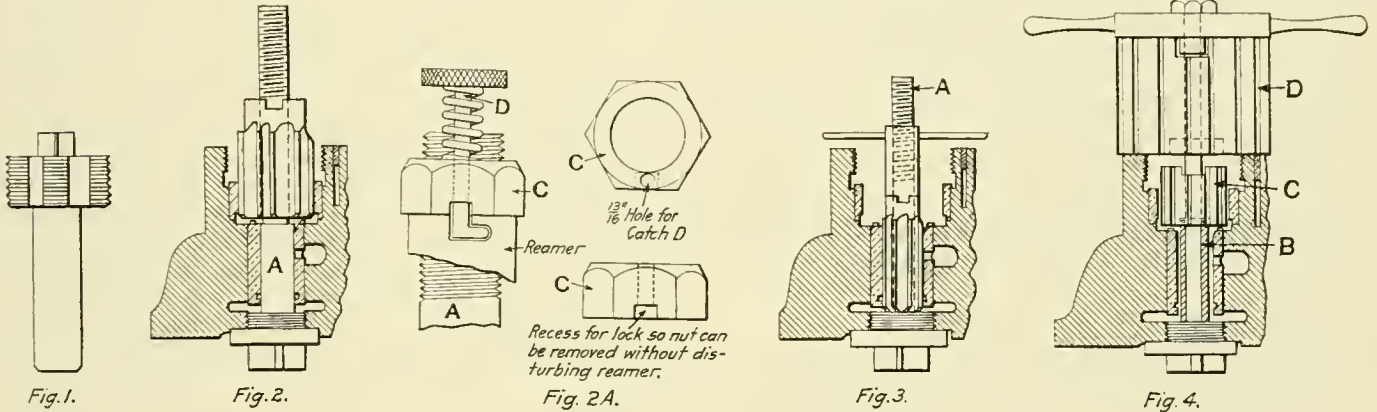

Method of Repairing Slide Valve Feed Valves

this class of work that is giving good results. It can be used in places where special power machines are not available.

The cylinder bushings are counterbored and cut off the correct size in a lathe. The slide valve bushings have the valve over lap groove and the counterbore on the boss end made preferably in a lathe, as neither of these operations interferes with the finished product, provided proper dimensions are adhered to.

The tap shown in Fig. 1 is used for extracting the old cylinder bushing. One end is made so that it forms a guide for the tap and is a close fit in the slide valve bushing. The tap is then run into the cylinder bushing a sufficient number of turns to secure a good grip on the bushing, which is then forced out by striking the guide.

When boring the cylinder bushing it is rough reamed to within about 0.002 in. of the size of the piston to be used, then finished to size as shown in Figs. 2 and 2A. The reamer is placed on pilot *A*, which is screwed into the tapped hole at the back of the feed valve. The reamer and the feed nut *C* are connected by catch or lock *D*, as shown, to prevent the reamer from traveling too fast. A wrench is used on the nut for turning the reamer. When through reaming, the catch is turned until the spring draws it clear of the reamer into the recess in the nut. The threads on the pilot are 20 per inch; the reamer has a 1 in. straight hole. It is essential that the reamer be fed slowly on fine cuts.

Fig. 3 shows a 1 1/8-in. shell reamer with a 3/4-in. straight hole, working over a pilot, which is fastened to the feed valve as indicated in Figs. 2 and 2A. This is used to finish the valve bushing, which is forced in with the inside diameter smaller and the bosses on the end longer than standard so they may be finished to standard dimensions. After the inside diameter of the bushing has been finished, the reamer is removed and a thimble is put over the pilot. This is of such length that when 1/16 in. is removed from the bosses by the 1 5/8-in. end mill *C* shown in Fig. 4, the thimble will fit bare on the face recessed

piston central in *B*; and *C*, *D*, *E*, *F* and *P* form a combined tool and post. The tool *D* is 1/4 in. in diameter, flattened on the upper side for the set screw *E*, and is operated by the feed screw *F*,

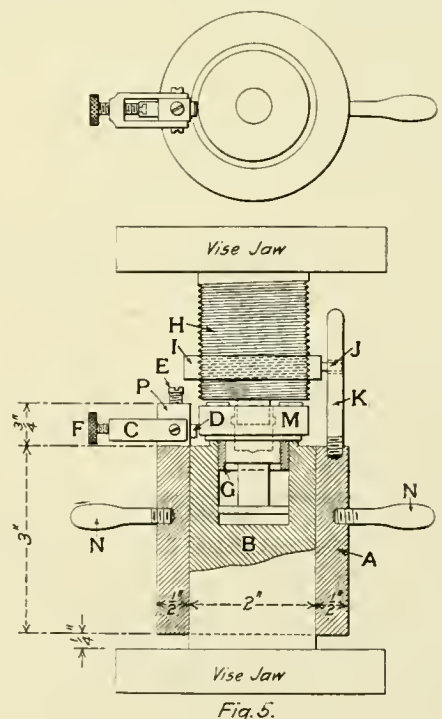

Part of the Equipment for Repairing Slide Valve Feed Valves

which is swivelly connected. A threaded block *H* carries a nut *I*. The ends of the block *H*, and piece *B* are clamped between vise jaws. This holds the piston *M* tight against the end of *B*;



the nut *I* is held by the pin *J*, which fits in a hole in the post *K*, the latter being screwed into *A* as shown.

Turning *A* with the four handles *N* causes the nut *I* to feed the cylinder *A* until the tool has cut across the face of the piston; it can then be reversed without moving the tool. The block *H* is  $1\frac{5}{8}$  in. in diameter by  $1\frac{5}{8}$  in. long, and has 20 threads per inch.

The piston will usually true up to about 0.005 in. or 0.006 in. less than the old size. An assortment of reamers is used, ground in dimensions of thousandths of an inch, beginning at 0.005 in. less than  $1\frac{3}{4}$  in., and so on. To finish the cylinder for the new standard piston a reamer  $1\frac{3}{4}$  in. plus 0.0005 in. is used. Whatever diameter the piston trues up, a corresponding size of reamer can be used for finishing the cylinder fit.

Templates should be kept for measuring the various sizes of pistons. An easy way to make them is to bore out old feed valve cap nuts and screw them into the body, then bore them out with the different size reamers, the same as in boring the cylinder bushings. Where a piston fits a template slightly loose a good method is to heat the feed valve body around the bushing. This will cause it to expand slightly; then bore while it is hot, and when it cools off it will be slightly smaller than if bored cold.

### IMPROVED TOOL HOLDER AND CENTER FOR WHEEL LATHES

BY C. M. NEWMAN

General Foreman, Atlantic Coast Line, South Rocky Mount, N. C.

The turning tools used on large wheel lathes are generally made from the best grade of high speed tool steel and are so large that they are very expensive. The accompanying engravings illustrate a tool holder made at the Atlantic Coast Line shops at South Rocky Mount, N. C., which uses  $1\frac{1}{4}$  in. by  $1\frac{1}{4}$  in. high speed tool steel. This holder has been tested on ten pairs of driving wheel tires by using it in one post and a tool made of the same make and grade of steel, but  $1\frac{1}{2}$  in. by 3 in., in the other post. The service rendered by the smaller

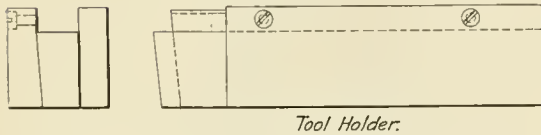
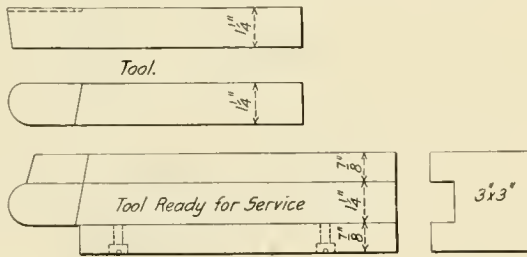

Right Hand Tool and Holder for 30 in. Wheel Lathe

steel in this holder was equally as good as that of the larger tool. It is also easier for the machine operator to handle the lighter tools, and the cost of maintenance is less than that of the heavy ones.

The greatest benefit to be derived from the use of this holder and the smaller steel is in the cost of applying a set of new tools. To equip a machine with a set of two roughing tools, ready for service, made of  $1\frac{1}{2}$  in. by 3 in. by 24 in. high speed tool steel costs approximately \$36, while a set of two roughing tools made of  $1\frac{1}{4}$  in. by  $1\frac{1}{4}$  in. by 24 in. high speed tool steel costs approximately \$14, a saving of \$22 on a set. When the

tools are worn to as short stock as can be used, about 7 in., we have in one case two pieces of  $1\frac{1}{2}$  in. by 3 in. by 7 in. steel worth about \$10, and in the other case two pieces of  $1\frac{1}{4}$  in. by  $1\frac{1}{4}$  in. by 7 in. steel worth about \$3.60, or a difference of \$6.40 in the value of the scrap. This steel can, of course, be reclaimed and used on smaller machines.

A set of two of these tool holders can be made for about \$8, including labor and material. Adding this to the cost of the tools gives a total cost of \$22 for the smaller tools and the

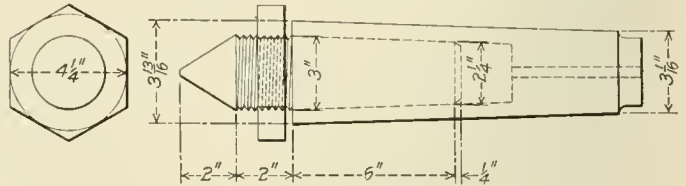

Center for Wheel Lathe

tool holders, which is \$14 less than the cost of two roughing tools made of  $1\frac{1}{2}$  in. by 3 in. steel.

It will be seen from the construction of the holder that the cutting edge of the tool is well supported. To remove the tool from the holder and the holder from the post is not any more difficult than to remove the large solid tool. The tool holder can also be used on boring mills and other heavy machines, and can be made to carry other styles of tools by changing the shape of the supporting end. If used on boring mills the holders should be made the same size as the tool steel originally used.

We have at times had the ends of the centers of wheel lathes broken due to excessive strain or to rough usage on the part of the operator. When an accident of this nature occurs it requires the removal of the end cap and screw in order to take out the broken center from the spindle and apply another, consuming from two to three hours of the operator's time as well as delaying the work on the machine. The other illustration shows an improved center which is now being used, and which, if broken, can be removed by a turn on the pull nut without removing any part of the machine, and another center can be quickly applied. In addition to the time saved by this change there is quite a saving in material when it is necessary to make a new center. The original centers were made of tool steel at an approximate cost of \$10 each. This improved style of center is made of tool steel at an approximate cost of \$2 for material, or a saving of \$8 for each center. The sleeve or bushing which carries the center is made of mild machine steel, and after application always remains in the spindle.

SIZE OF EXHAUST NOZZLES.—An account of experiments on locomotive blast pipes or exhaust nozzles and funnels is given by G. Strahl in the *Zeitsch. des Ver. deutsch. Ingen.* for November 1. The experiments were conducted with stationary and moving locomotives on the Prussian State Railway, and confirm in general the theory of Zeuner upon which the formulas which are at present in use for the calculation of the funnels and blast pipes of German locomotives are based. He finds, however, that the diameter of these parts of the engine should be a little greater than that given by Zeuner's theory. He finds that this increase in their dimensions does not interfere with the full draft of the locomotive. In practice the best funnel—that is, the one which permits the employment of the blast pipe of largest diameter—usually requires a space between it and this blast pipe impossible to realize on account of the limited dimensions of the smoke box. In this case, the blast pipe should be placed as low as possible, and should have the maximum diameter compatible with that of the exhaust ports so as to give a funnel as large as possible.—*The Engineer.*

# TOOLS FOR LOCOMOTIVE REPAIRS

Attachments for Work on Eccentrics and for the Operation of Air Motors in Close Quarters

BY R. S. MOUNCE

MANDREL FOR TURNING ECCENTRICS

The mandrel shown in Fig. 1 is used for turning eccentrics on a boring mill. Two lines are laid off on the table and through the center of the machine, at right angles to each other. Two studs are applied on one of these lines at distances of 9 in. and

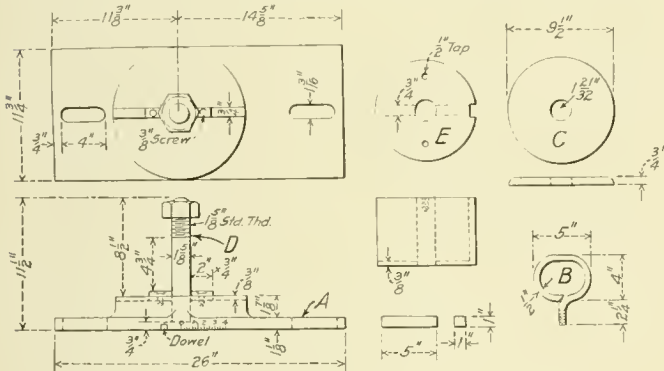

Fig. 1—Mandrel for Turning Eccentrics on a Boring Mill

12 in. each side of the center, for the purpose of holding the base *A* of the mandrel on the boring mill table. The other line forms an index for setting the mandrel by means of the scale on the side of the base to any desired throw. With the spacing of the holding studs, together with the slots in the

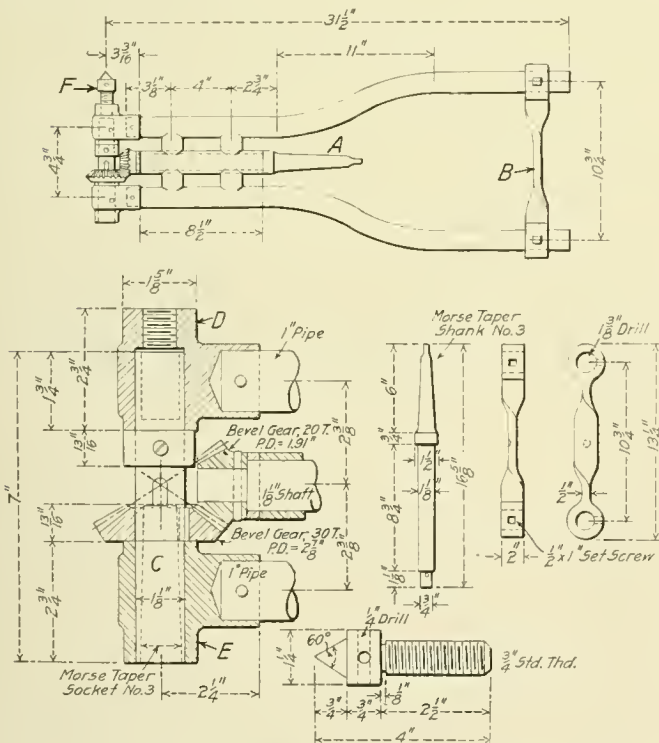

Fig. 2—Right Angle Attachment for Air Motors

base of the mandrel, any throw from 4 in. to 9 in. may be obtained, which more than covers all the sizes of locomotive eccentrics. The scale is graduated in quarter inches, and the setting is always equal to one-half the throw. Several sizes of man-

drels *E* are required with this apparatus to fit the several sizes of eccentrics. The mandrel has a keyway, which fits over the two small keys on the boss of the mandrel base; it also has a keyway corresponding to the keyway in the driving axle, so that eccentrics may be keyed in place on the mandrel, thereby insuring accuracy in turning. Handles *B* are provided to facilitate applying or removing the mandrel from the base. After the eccentric has been applied and keyed to the mandrel, there remains only to place the cover plate *C* over the bolt *D*, and to tighten the nut, drawing the whole securely together.

CLOSE QUARTER ATTACHMENT FOR AIR MOTORS

By means of the device shown in Fig. 2, drilling and reaming can be done with an ordinary air motor in as limited a space as with a specially designed close quarter motor. The attachment shown in the drawing makes the purchase of close quarter motors almost unnecessary; it is not a costly apparatus to

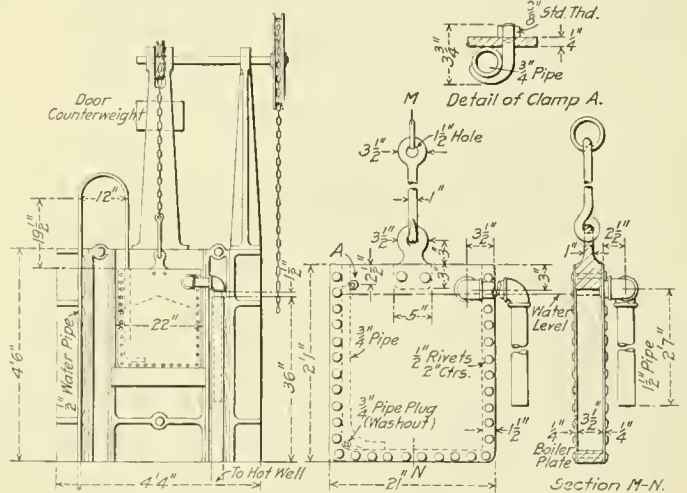

Fig. 3—Water Jacket Door for Oil Furnace

make, nor is its maintenance expense high, provided it is given sufficient lubrication and is handled with reasonable care. The air motor is attached to the driving shaft *A*, and is held in position by the cross bar *B*. This shaft rotates in a brass tube, which is brazed to the frame of the apparatus; and the bevel gear at its extremity mates with another bevel gear on the spindle *C*. The spindle revolves in the bearings, *D* and *E*, which are brazed and pinned to the ends of the frame. It is bored to take a Morse taper shank No. 3, and is provided with a drift-key slot to permit of backing out the drill or reamer. The other end of the spindle is cupped out so that the feed screw *F* may have a reasonably long travel. It is well known that the speed of air motors is rather high for large sized drills or reamers. An advantage of this close quarter attachment is that the bevel gears may be designed so as to give a considerable reduction of speed. By changing the dimensions of all parts as far as may be necessary, an attachment may be constructed for several sizes of motors and for the corresponding sizes of drills and reamers.

IMPROVED DOOR FOR OIL FURNACES

A water front door is shown in Fig. 3 as applied to a Ferguson spring banding oil furnace, although it may readily be applied to any similar forging furnace. It is operated the same as the cast



iron, fire brick lined door with which the furnace was originally equipped. It is so designed that, regardless of the position of the door, cold water is always flowing in and hot water flowing out. The  $\frac{3}{4}$  in. intake pipe is clamped in the water front, as shown, so that the cold water enters at the bottom of the door.

boilers. This improvement was devised by T. J. McCann, blacksmith shop foreman at the Cleveland shops of the Erie Railroad.

MILLING ECCENTRIC KEYWAYS

The details and assembly drawings of a device for milling eccentric keyways in axles are shown in Figs. 4 and 5. It is driven by an air motor which fits on the spindle *A*. The body of the jig fits over the axle and is rigidly held to it by chain clamps which extend around the axle. These clamps consist of a bar *B*, Fig. 5, swung from hooks in the side of the jig body by chains. A 1 in. set screw passes through the clamping bar bearing on the under side of the axle and is used to do the actual clamping. The air motor and milling tool are carried on one end of the slide *C*, Fig. 4, which is fed in and out by the feed screw *D*. The milling tool is raised or lowered through the screw bearing *E* and when correctly located is held by the lock nut *F*. The method of operation is briefly as follows: The device is centered in relation to the indicated location of the eccentric keyway, and is then rigidly fastened to the journal by means of the chains and clamping device. The driving power is furnished by an air motor attached to the driving spindle, which transmits motion directly to the end mill. It is generally advisable to drill a clearance at each end of the keyway, thereby making the work of the end mill easier. In milling the keyway, the end mill is lowered a suitable amount by means of the vertical feed screw and is held rigidly in its vertical position by the lock nut. By turning the crank in the proper direction, the cut is taken the length of the keyway. The mill is again lowered and the cut is taken across in the opposite direction, and so on until the keyway is completed. Feeding is, of course, all done by hand, but a set of keyways can be laid out and milled completely in from seven to nine hours.

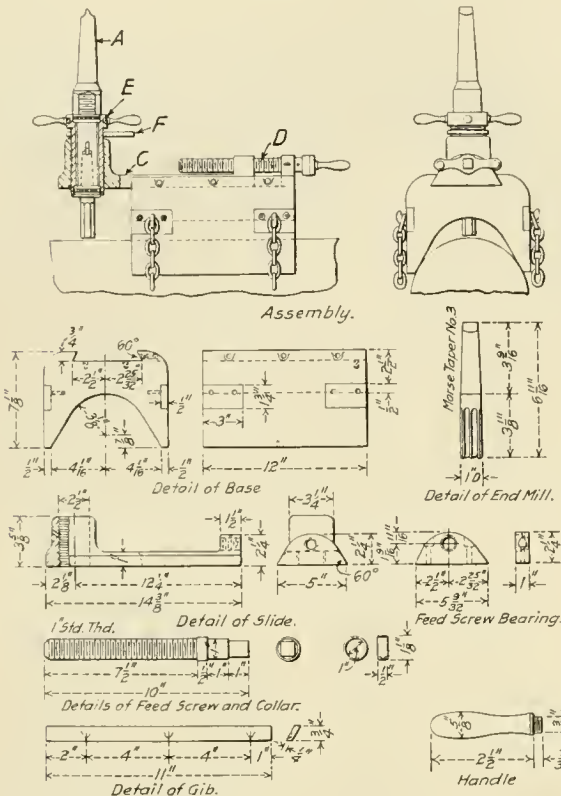

Fig. 4—Air Driven Milling Cutter for Cutting Eccentric Keyways

The  $\frac{1}{2}$  in. feed pipe is small enough to pass freely into the intake pipe and when the door is at its lowest position, the end of the feed pipe is  $1\frac{1}{2}$  in. below the top of the intake pipe. The  $1\frac{1}{2}$  in. overflow pipe is tapped in the outer door sheet, near the top, sliding freely in the 2 in. drain pipe, and when the door is at its highest position, the overflow pipe is several inches below

ABOLISHING DEAD BUFFERS IN ENGLAND.—Beginning January 1 no dead buffer vehicles have been run on the railways in England and Wales. In Scotland the conversion is to be completed by the end of 1915, and the traders have been informed that all dead buffer wagons must be converted into spring buffer wagons by that date.—*The Engineer*.

SELF-PROPELLED CARS.—On many railways abroad the self-propelled car has been in use for a long time. In accordance with the former state of engineering knowledge, most of these

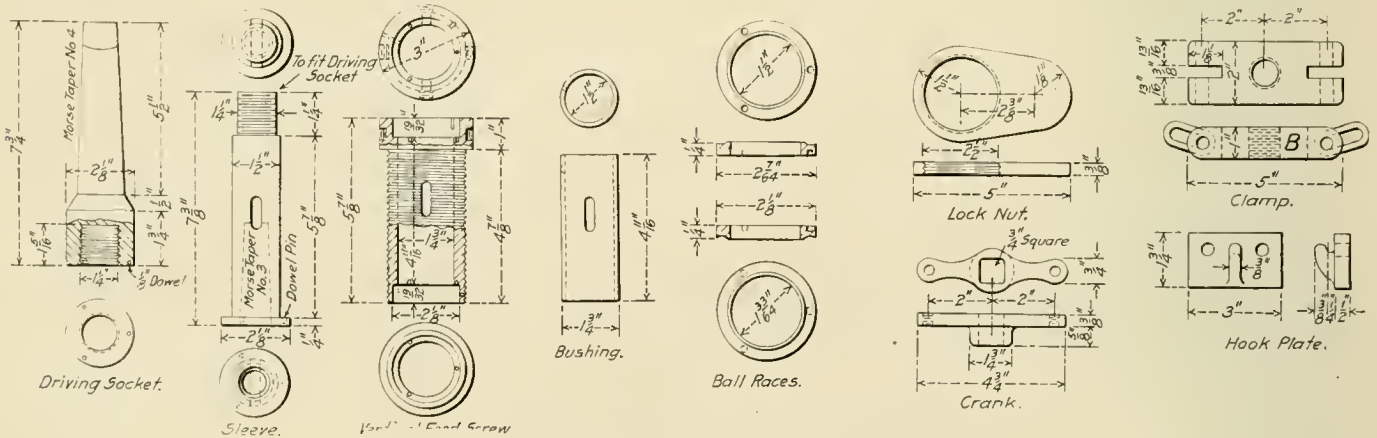

Fig. 5—Details of Machine for Milling Eccentric Keyways

the top of the drain pipe. The construction of the door is quite simple. The inner and outer sheets are made of  $\frac{1}{4}$  in. boiler plate and are riveted to a frame of  $1\frac{1}{2}$  in. by  $3\frac{1}{2}$  in. bar iron with tar paper between the frame and the sheets. At one of the lower corners, a  $\frac{3}{4}$  in. pipe plug is provided for the purpose of washing out the water front. The water never reaches the boiling point and there is no waste, as the hot water flows to a hot well from which the water is drawn for washing locomotive

cars used to be steam cars. It is only lately, in consequence of the progress made in electrical science and of the resulting enormous development of tramways, and of the improvements made in internal combustion motors, that a number of other types appeared, which have many advantages as compared with steam cars. It is no doubt due to this that rail motor cars have come into extensive use.—*Bulletin of the International Railway Congress*.

# INSTALLATION AND MAINTENANCE OF ELECTRIC HEADLIGHT EQUIPMENT

BY V. T. KROPIDLOWSKI

## VI

In this, the last article of the series, the writer will deal with the steam turbine, taking up only those principles that are essential to the proper care and operation of a turbine of this kind. Some knowledge of its main principles on the part of the reader will be assumed.

The principle upon which the turbine operates is quite generally understood, but it may be well to refer to the reasons why steam acquires such a great velocity as compared with water. The law of gravitation governs in this case, as elsewhere. In

116 ft. and 47,032 ft. The velocity of the water is,  $\sqrt{64.32 \times 116} = 86.5$  ft. per second, and of the steam,  $\sqrt{64.32 \times 47,032} = 1,798$  ft. per second. These velocities, of course, are theoretical.

A question that is often asked is, "Why is the efficiency of the headlight turbine so low?"; or to put it in more usual form, "Why does this turbine consume so much steam compared with larger turbines?" There are many factors to be considered, but the principal reason why a small turbine or any other prime mover cannot be made as efficient as a large one is because, to begin with, the large unit does not work at 100 per cent efficiency and therefore when the size is reduced the efficiency must be considerably less.

The principal loss in a steam turbine is the rotation loss of the wheel revolving at high speed in certain atmospheric conditions inside the turbine casing. In a large machine this amounts to

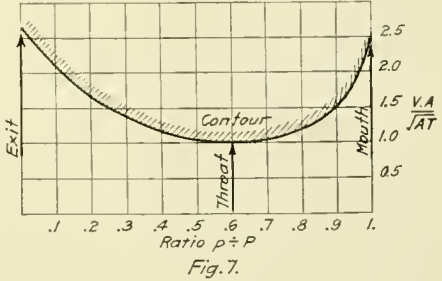
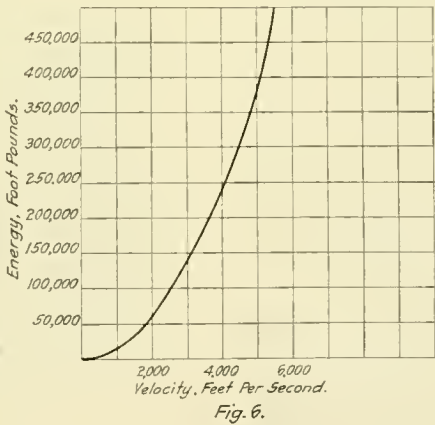
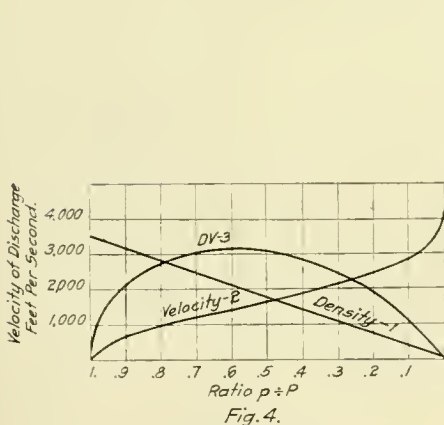
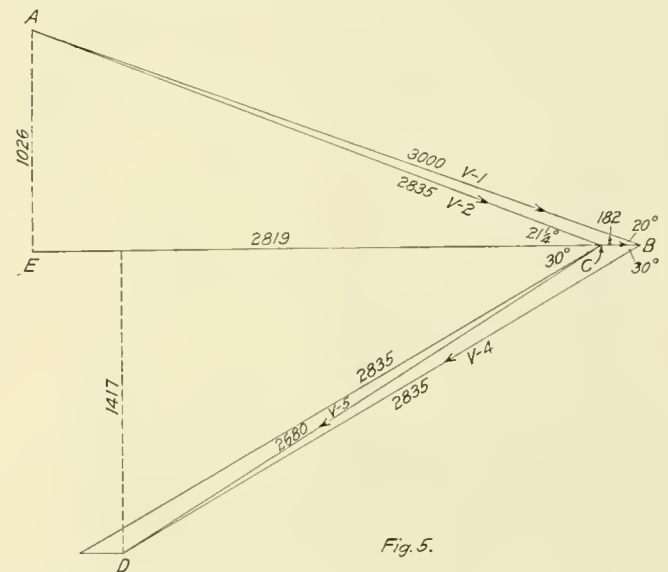
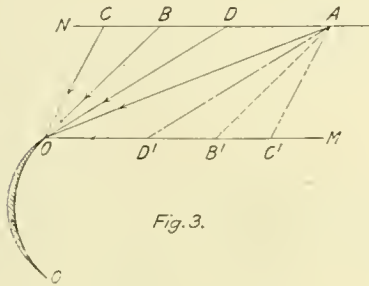
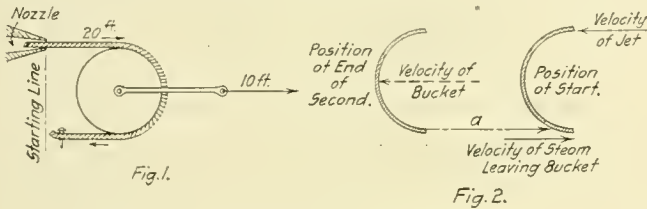

Diagrams for Use in Electric Headlight Turbine Calculations

order to impart motion to a body or mass there must be a difference of level, or pressure, and the greater the difference the greater will be the velocity. The formula for the velocity acquired by a falling body is  $\sqrt{2gh}$ , where  $g$  represents the force of gravity, 32.16, and  $h$  the height, or head, through which the body falls. The height of a column of water equivalent to a pressure of 50 lb. is,  $50 \div .4335$  (the weight of a cubic inch of water) and the height of a column of steam at that pressure, assuming that the density of the steam remains constant is  $144 \times 50$

in which 144 is the number of square inches in a .1533 square foot and .1533 is the weight of a cubic foot of steam at 50 lb. gage pressure. The heads, therefore, are respectively,

only 1 or 2 per cent, whereas in a small one it might be as high as 20 per cent or more. A further heavy loss in a turbine of the single or double wheel impulse type is due to the speed. In order to absorb all the velocity from the steam jet, the buckets in this turbine would have to travel at such a rate of speed as would be entirely impracticable. This residual velocity which the steam has after leaving the last bucket is the other great cause for inefficiency in a small turbine. Furthermore, there is only a very small portion of the periphery of the wheel utilized, while in a large machine the total circumference is used. Another thing that is not taken advantage of in the operation of small turbines is the condenser, which is the most effective agent in reducing the steam consumption when it is remembered that there is as much power in steam in expanding from atmospheric



pressure down to 27½ in. of vacuum as there is from 150 lb. down to atmospheric pressure. By using Carnot's formula,  $\frac{T_1 - T_2}{T_1}$ , where  $T_1$  is the absolute initial temperature of the steam entering a heat engine and  $T_2$  the temperature of the steam leaving, we can see that the lower the exhaust temperature the more work will be obtained from the steam.

The inefficiency of the turbines used for electric headlights, aside from the unavoidable features mentioned above, is also largely due to the necessity of making a cheap machine in order to keep the price down to an amount which the railway companies are willing to pay. By the machining of the surfaces in the wheel and the addition of other refinements, a much more economical machine could be produced. Even a reasonable increase over the price of the present headlight turbine would produce a machine that would run on 80 lb. or 100 lb. of steam per horse power hour, as against the present consumption of 175 lb. to 200 lb. Dull bucket edges, as furnished in the small jobbing machines, also cause a loss, as do also the rough surfaces of the bucket walls and nozzles, and of the sides

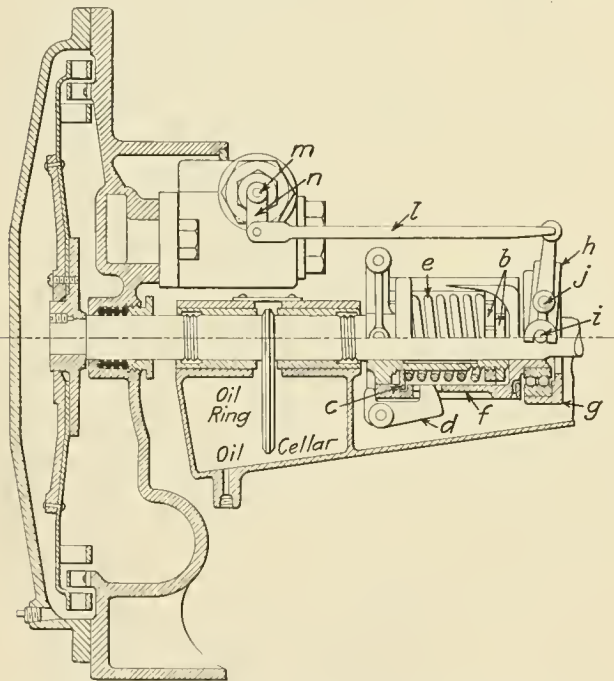

Fig. 8—Turbine End of American Generator

of the wheels. All these losses are much greater in a small machine than in a large one.

In an impulse turbine the periphery, or we will say a point, such as a bucket on the wheel, must travel half as fast as the steam that issues from the nozzle in order to be able to absorb all the velocity from the jet. When this condition is fulfilled the steam will have no velocity in relation to the stationary part of the turbine, and it will merely be paying out like a rope from a reel, as illustrated in Fig. 1. In an ideal turbine, the buckets would be shaped as in Fig. 2, so as to completely reverse the direction of the steam, but in practice they cannot be so shaped for the reason that the steam leaving the buckets would strike the backs of the other buckets, as indicated by the arrow *a*, Fig. 2. To avoid this they are shaped similarly to the bucket *oo*, Fig. 3.

Let us now take a concrete case and see what the possible efficiency would be. Assuming an initial pressure of 200 lb. per square inch and a final pressure of one atmosphere, the ratio of the pressures is .075. From Fig. 4 we find that the velocity of the jet from a properly designed nozzle, with no nozzle losses, is 3,000 ft. per second. Laying this off to scale, so that

the length will represent the 3,000 ft. per second, and making an angle of 20 deg. with the line *E-B*, which represents the wheel, we will call this  $V_1$ , Fig. 5. Then  $AE = 3,000 \sin. 20 \text{ deg.} = 1,026$ , and  $BE = 3,000 \cos. 20 \text{ deg.} = 2,819$ ; whence  $CE = 2,819 - 182 = 2,637$ ;  $CB$  is the peripheral speed of a 14 in. turbine wheel under these conditions and is 182 ft. per second. The angle  $ACE$ , which the relative velocity,  $AC$ , of the steam makes

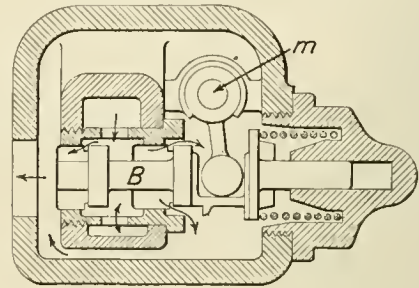

Fig. 9—Section Showing Valve of American Generator

with the plane of rotation, is the angle whose tangent is  $1,026 \div 2,637 = .388$ ; the angle is 21.25 deg. The relative velocity  $V_2$  is  $2,637 \div \cos. 21.25 \text{ deg.} = 2,835$  ft. per second. Now assuming no loss by reason of the shock at the entrance to the blade, due to the steam striking on the edge, and neglecting friction losses, the steam will leave the blade with a relative velocity of 2,835 ft. per second and at an angle of 30 deg. (the blade angle) with the plane of rotation. The triangle of velocities at the exit is then represented by  $BCD$ , and  $V_3$ , the actual velocity of the steam

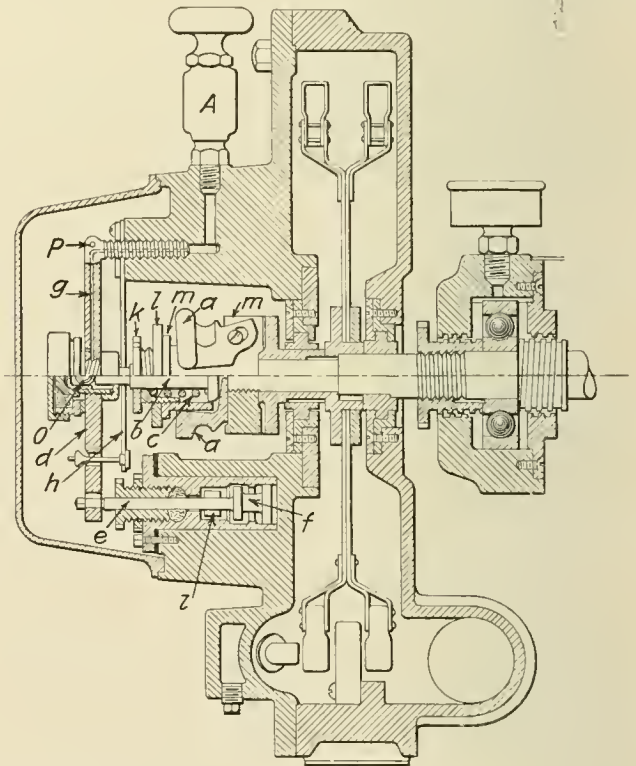

Fig. 10—Turbine End of the Schroeder Generator

leaving the wheel, is 2,680 ft. per second. The maximum possible efficiency in this case is then  $\frac{3,000^2 - 2,680^2}{3,000^2} = 20 \text{ per cent, nearly.}$

But most of the turbines use the steam twice, that is, the jet is re-directed against the wheel, and in that way the remaining velocity is reduced. By repeating the process of calculations,

we obtain for the absolute velocity of the steam leaving the wheel 2,074 ft. per second, the efficiency being increased to about 50 per cent.

If we now wish to know the possible steam consumption of the turbine we can get at this in the following manner: The steam pressure at which these turbines are usually worked in actual service is about 150 lb. and by referring to Fig. 4 we ascertain that steam expanding from 150 lb. down to atmospheric pressure (the ratio of  $p \div P$  being .09) has a velocity of approximately 2,933 ft. per second. From Fig. 6 we learn that the energy due to this velocity is about 132,500 foot-pounds. Of course the quality of the steam is not 100 per cent., but will be somewhere near 96 per cent., reducing the energy to 127,200. Furthermore, the nozzles used in these turbines are not perfect, and we will assume the efficiency of the nozzle to be 60 per cent. so that the available energy is again reduced to

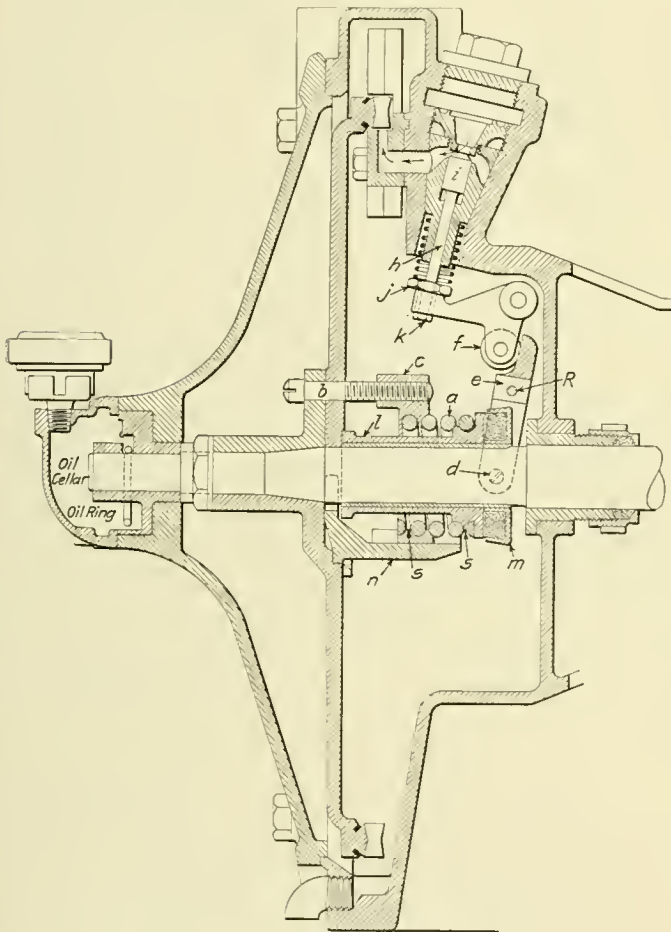

Fig. 11—Turbine End of Pyle-National Generator

76,320 foot-pounds. As mentioned before, the windage and friction losses of the wheel in a small turbine of this kind amount to about 25 per cent, reducing the efficiency of the turbine to  $50 \times .25 = 12.5$ , and  $50 - 12.5 = 37.5$  per cent, the turbine utilizing 37.5 per cent of the available energy, 76,320 foot-pounds, which amounts to  $76,320 \times 37.5 = 28,620$  foot-pounds. The theoretical steam consumption per horse power hour is then  $1,980,000 \div 28,620 = 70$  lb., 1,980,000 being approximately the foot-pounds per horse power hour. This would be very economical for a turbine of this kind, but from actual tests it is found that these turbines consume from 180 lb. to 200 lb. of steam per horse power hour. The actual efficiency, therefore, if we take the higher rate of consumption, is  $70 \div 200 = 35$  per cent; and 35 per cent of 37.5 = 13 per cent, which is the actual efficiency. The efficiency loss due to mechanical construction is, therefore  $37.5 - 13 = 24.5$  per cent.

It is essential that the turbine speed be kept up to its rating, not running below or above that speed to any extent. The steam pressure should also be maintained as specified by the manufacturers as by varying any of these the efficiency is impaired and steam consumption increased. This will be seen by referring to Fig. 3. For example, consider the actual velocity of the steam as constant and vary the speed of the wheel. Thus, let  $OO$ , Fig. 3, be the blade and  $BO$  the tangent to its curve at the point of entrance. Let  $AO$  be, to the same scale, the actual direction and velocity of the steam leaving the nozzle. Let  $MO$  be the direction of motion of the wheel. Draw  $AN$  parallel to  $MO$  and cutting the tangent  $BO$  at the point  $B$ . To prevent shock, the relative velocity of the entering steam must be in amount and direction that of  $BO$ . Completing the parallelogram  $ABOB'$ ,  $B'O$ , equal to  $AB$ , is the proper speed for the wheel. For, if speed of the wheel be greater than  $B'O$  as  $C'O$ , the parallelogram of velocity is  $AC'OC$ , and  $OC$  is the relative velocity of the steam, which will strike the back of the blade, wasting energy in a downward thrust on the shaft. The same will be true if the wheel is not running fast enough, and also if the velocity of the steam is varied by varying the pressure. From this it is seen that it is very important to maintain the speeds and velocities for which the turbine is designed. It is also important to see that the nozzle is properly designed, as

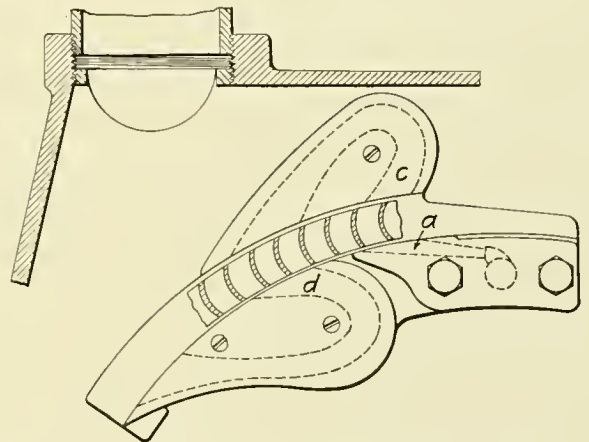

Fig. 12—Enlarged View of Steam Nozzle and Reversing Chamber of Pyle-National Turbine

upon it depends the velocity of the steam, and consequently the energy in foot-pounds. Wet steam should also be avoided, as it is very injurious to the buckets, wearing them out quickly.

There are various designs of nozzles, but a correct design is only produced after careful experiment. We know that with the convergent nozzle we can obtain just so much velocity and no more, and no matter how much we reduce the steam pressure at the exit end, or increase the steam pressure at the entrance end of the nozzle, we can obtain only the velocity due to the ratios of  $p \div P = .58$ , which is 1,446.5 ft. per second. But with a divergent nozzle we are able to obtain various velocities (within the limits, of course, of expansion) according to the design of the nozzle. Fig. 7 shows the theoretical half-contour of a divergent nozzle, which is calculated from the velocity and density when controlling its expansion gradually. All the data for this curve are obtained from Fig. 4.

The vital part of a steam turbine is the governor, and this and the bearings are the only things about the machine that demand the attention of the operator and attendant. If these features are properly looked after and maintained very little trouble will develop, aside from something unusual and unforeseen that may happen once in a great while.

Fig. 8 shows the turbine end of the American machine. The speed of this machine is regulated by screwing the two spanner nuts  $b$  either to the right or left, depending on whether it is running fast or slow. A very slight turn makes quite a difference in the speed. As the nuts are turned to the right they



compress the spring *c*, putting more tension on it, and the turbine must revolve faster in order to increase the centrifugal force of the weights *d* so they will be able to push the frame *f* against the tension of the spring. The operation of the governor is as follows: The weight *d* presses down with its heel on the end of the frame *f*. The plate *c* resists the movement of the frame due to the tension of the spring, but the centrifugal force overcomes it and the frame communicates its motion to the ball bearing case *g*, which in turn moves the yoke *h* by means of the pin *i*. The yoke *h* is pivoted to the main frame of the machine by the pin *i* and transmits the motion to rod *l*, which moves the arm *n*. The arm in turn revolves the shaft *m*, upon which is another arm inside the valve chamber; the inner arm is what closes the valve *B*, Fig. 9. Ordinarily the valve is open, due to the tension of the governor spring *c*, and the steam enters the passages to the nozzles as indicated by the arrows in Fig. 9.

The importance of maintaining the valve gear of this machine cannot be too strongly emphasized, as any lost motion in the pin connection has the same effect on the speed of the machine as increasing the tension of the spring of the governors, for the reason that the travel of the frame *f* must be greater to overcome the lost motion and, consequently the spring must be compressed to a greater degree, requiring more centrifugal force.

Fig. 10 is the turbine end of the Schroeder generator. To regulate the speed of this machine, loosen the nut *l* and screw the gland *k* to the left or right, according to whether it is desired to decrease or increase the speed. The operation of the governor is as follows: The centrifugal force throws out the weights *a* and the heels of the weights push on the arbor *b*. The spring *c* resists the movement of the arbor *b*, but finally it is overcome by the centrifugal force of the weights and the arbor *b* moves the steel plate *d* by exerting a thrust on the ball bearing *o*. Plate *d* being pivoted at *P* pulls on the valve stem *c* (the stem being part of the valve *f*) closes it and shuts off the flow of steam from chamber *i*, which communicates with the passage to the nozzle. In this connection it is well to draw attention to the necessity of making sure that lubricant is at all times in the cup *A*, and that the passages *g* are not obstructed with dirt. In one case the ball *o* was found welded to the end of the arbor *b*, due to the lack of lubrication.

Fig. 11 shows the turbine end of the Pyle-National generator. To regulate the speed of this machine, turn the two screws *b* (only one is shown) to the right or left as the case may be. One or two turns make considerable difference in the speed. The operation of this governor is as follows: Centrifugal force throws the weights *n* out (only one weight is shown) and their heels push on the end of the sleeve *l*. The tension of the spring *a* resists the movement of the sleeve *l* until the centrifugal force of the weights overcomes it, stretching the spring by means of the worm *s*, which is part of the sleeve and moves the round carbon casing *m*. This casing in turn moves the yoke *e*, which is fastened to it at *d*. The yoke being pivoted to the main casing of the machine at *R*, throws out the lower arm of the bell crank *f*, the upper arm of which pushes the valve stem *h* up and closes the valve *i*. It is very important to see that the distance between the valve *i* and the seat is correct (the adjustment being made by nuts *j* and *k*) as, if the distance is too great, the turbine will speed up, because the sleeve *l* will have to travel farther and, consequently, the springs will have to be stretched more, requiring a greater centrifugal force. The opposite will be true if the distance is too small.

Fig. 12 is a larger view of the steam nozzle and reversing chambers of the Pyle machine. The steam leaves the nozzle *a*, impinges on the wheel buckets, flows into the reversing chamber *c*, is redirected on the buckets, as will be seen by following out the dotted lines, and leaving the buckets the second time, enters the chamber *d*.

### SMITH SHOP TOOLS

BY J. F. PERRITT

Foreman Blacksmith, Seaboard Air Line, Jacksonville, Fla.

#### SHEARING DRAWBAR RIVETS

Fig. 1 shows a device for shearing rivets from drawbars that are to be repaired. It can be easily attached to a machine punch. This tool works so satisfactorily and is such a time and labor saver that it will pay for the trouble of making it in a very short time. Referring to the drawing, *A* is the main plate which is attached to the machine; *B* is a clamp to prevent slipping or turning; *C* is an adjustable slide to suit the width of the draw-

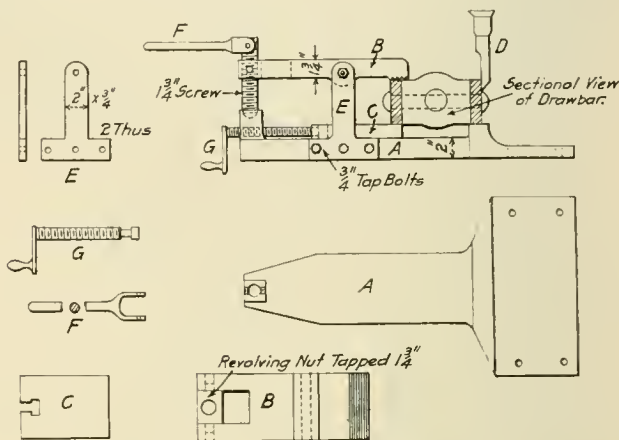

Fig. 1—Tool for Shearing Drawbar Rivets

bar; *D* is the punch which is milled flat on one side and dressed as a side set; *E* are standards to support the clamp; *F* is a reversible handle for operating the clamp by a 1 3/4-in. screw, and *G* is the crank screw for operating the slide. In shearing, the rivet should be backed up by a guide to avoid springing. This guide can be attached in the same manner as the stripper used on a machine punch.

#### TOOL FOR MAKING END DOOR HANGERS

Fig. 2 shows a tool used on an air machine for making end door hangers for freight cars. No sizes are given as they are

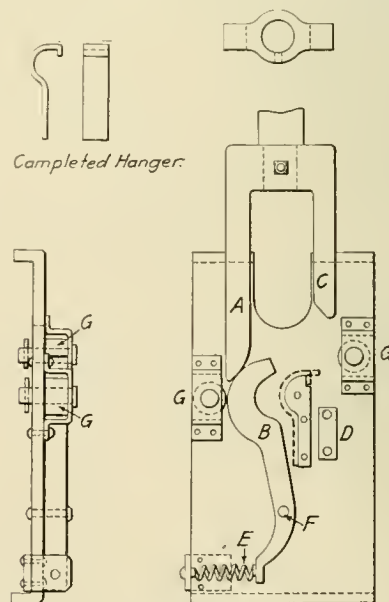

Fig. 2—Tool for Making End Door Hangers

governed by the hanger to be made. One application of the air completes the hanger. In operation, the long portion of the plunger *A* moves forward, forcing *B* over and forming the

bent portion of the hanger, as shown by the dotted lines. In moving forward, C, following A and B, completes the hanger by turning forward, the coil spring E forces B back so that it is ready for the next operation. The loose rivet F acts as a pivot and the rollers G are to reduce friction on A and C.

PUNCHING OUT HINGES

Fig. 3 shows a tool used under a steam hammer for punching out hinges. No dimensions are given as these are regulated

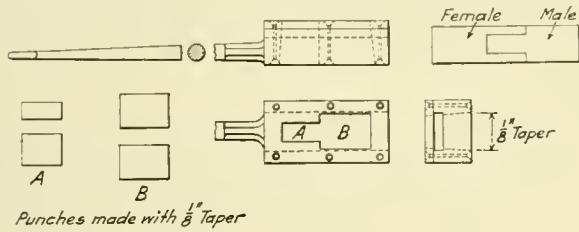

Fig. 3—Tool for Punching Out Hinges

by the hinges required. The punches are made exactly the same length and are placed in the tool as indicated by the letters A and B.

AUTOGENOUS WELDING IN LOCOMOTIVE FIREBOXES

BY N. H. AHSIUOLH

The firebox repairs, illustrated in this article, have had over six months' service and have developed no leaks or trouble of any kind due to the welding.

Fig. 1 shows the operation of welding a crack in a mudring in running repairs. This crack is shown in the sketch and developed about four months after the engine had received a general overhauling. All of the grates and frames, and one corner piece of the ash pan, were removed, and it was necessary to take out 12 corner mudring rivets and remove six staybolts. The corner pieces of the firebox side and flue sheets were cut

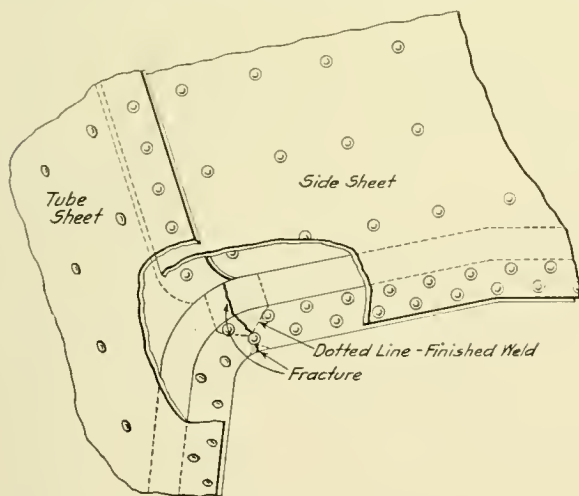

Fig. 1

out as shown, ground bevel along the cut out edge, annealed, and laid one side. The outside corner plugs of the throat sheet were removed to allow the mudring to expand and contract during the operation of welding. The mudring was chipped out in a V shape both ways from the bottom rivet hole. This opening was then filled in from the hole down to the bottom edge of the mudring, using the oxy-acetylene torch and 1/4 in. swedish iron for flux. From the rivet hole to the top edge of the ring was next welded, filling in until the original thickness of the ring was restored. The weld

was tested with a 20 lb. sledge after it was cold and developed no fractures. After chipping the face of the ring smooth, the old pieces of the side and flue sheets were bolted in place and welded. As the mudring contracted about 1/8 in. during the operation of welding the fracture, the outside corner of the throat sheet was refitted and corner plugs applied. The rivets and staybolts were then applied and no leaks developed at any of the welds during the hydrostatic tests. The entire operation consumed 35 hours, with a minimum amount of stripping. Three other engines, two of which

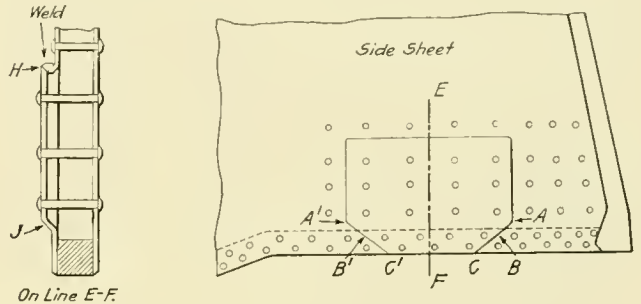

Fig. 2

had back corners fractured, have been repaired in the same manner, and have been equally successful.

In Fig. 2 is shown a patch applied to a right side sheet near the back mudring corner to renew a mudburned portion of the sheet. The side sheet was ripped out as indicated, and the edge of the old sheet from A to A' was flanged out toward the fire side as at H. From A to C and from A' to C' the edge was chipped at 60 deg. bevel on the fire side of the sheet. The patch was offset along a line from A to A' as at J and fitted up flush with the old sheet along the mudring to allow for the grate frames. The edge of the new patch from A' to A was chipped with a reverse bevel of 30 deg. as at H. The flush welds from A' to C' and A to C were first made, the old sheet being kept red hot at B and B' until the respective welds were completed, so that the draw resulting from the contracting of the welds in cool-

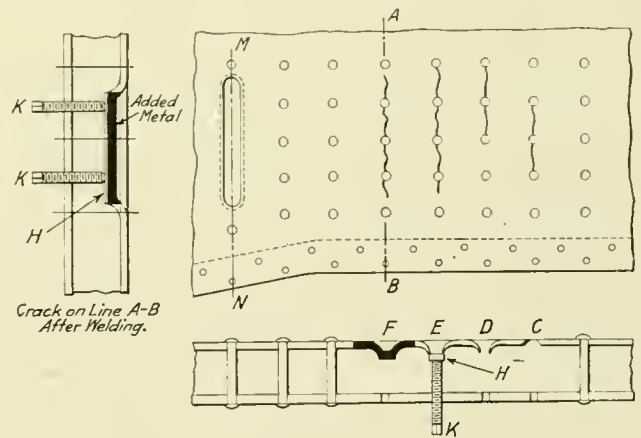

Fig. 3

ing would be in the old sheet, and not disturb the position of the patch. The box weld from A' to A was next completed and the rivets and staybolts applied.

In a patch of this kind the draw resulting from the cooling of the welds is at a right angle with the plane of the sheet. This draw keeps the patch tight against the flange of the old sheet, as a result of which it is not necessary to keep any clamps on the patch to hold it in position.

In Fig. 3 is shown a method of welding cracks in the side sheets of wide fireboxes. Cracks have been successfully welded in a number of side sheets, this particular illustration



showing the firebox of an oil burner which has had over six months' service since the welding of the cracks was completed.

There were four adjacent cracks in the right side sheet near the door sheet. The staybolts were removed and the cracks chipped out for their entire length as shown at *C*, leaving an opening about  $\frac{1}{4}$  in. wide. The sheet was then heated with the gas torch for a distance of  $1\frac{1}{2}$  in. back from the edge of the chipped out portions, and bent in toward the water space as shown at *D*. This left an opening  $1\frac{1}{2}$  in. wide and the length of the crack, as shown on the line *MN*. A piece of  $\frac{1}{8}$  in. steel  $1\frac{1}{4}$  in. wide, *H*, was then shaped to cover the opening *D*. This piece was placed against the edges of the opening on the water side, the hole in the outside sheet was tapped and the staybolt *K* run against the  $\frac{1}{8}$  in. piece to clamp it in position during the welding. The edges of the opening and the  $\frac{1}{8}$  in. piece were then welded, the opening being filled with iron from  $\frac{1}{4}$  in. stick flux until the original  $\frac{3}{8}$  in. thickness of the sheet was obtained as at *F*. The staybolt holes were then drilled and the staybolts applied in the usual manner. This method has been standard with the writer, and has never resulted in a failure of any kind after the engine left the shop.

This operation of welding cracks illustrates further the idea of compensating for the contraction of cooling welds, by removing the area of contraction from the general plane of the side sheet, the contraction in this case being at right angles to the plane of the sheet, instead of in the same plane, as when flush welding of cracks is attempted.

In autogeneous welds as made by the writer there is no preheating of sheets, nor are any preparations made other than to fit up the patches and sheets ready to weld. There is

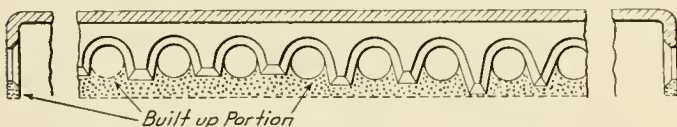

Fig. 4

no movement of any patch or sheet where the box weld is used and all the holes can be punched in the sheets before the welding. In patches where the flush weld is used the holes are generally left blank, and drilled after the welding is completed.

In oil burning locomotives, equipped with the front end burner, the top and side door sheet seams give much trouble by leaking, due to the intense heat in this part of the firebox. Repeated caulking in the roundhouse soon reduces the lap, as a result of which a new door sheet is often necessary when the engines are shopped. Since the advent of gas welding such repairs are made by chipping the flange holes in a V shape as shown in Fig. 4. The opening is then filled in to the edge of the lap with stick flux, made of sheared strips of forebox plate,  $\frac{5}{16}$  in. square. The holes are then reamed and countersunk, and rivets or patchbolts applied.

**PRECOOLING PERISHABLE FREIGHT.**—The precooling of perishable freight before it is placed in refrigerator cars has become recognized as very desirable. There are certain classes of perishable freight, such as meats, dairy products, etc., with which it is absolutely necessary to do this. In these cases the precooling is usually done in cold storage warehouses, and the cars iced for a sufficient time before loading to insure the proper temperature inside the car when the products are loaded. In the case of fruits and vegetables, while precooling is very desirable, it is not absolutely necessary. A carload of fruit will probably take two or three days to reduce to the proper temperature if loaded without precooling, whereas by precooling either in the car or in the cold storage warehouse, this reduction of temperature may be accomplished in a much quicker time.—*Railway Age Gazette.*

## THE APPRENTICE—A BOY

BY A. B. KERR

Instructor of Apprentices, St. Louis & San Francisco, Springfield, Mo.

Apprentice education is practically a new department of railroading, but it is a department of very great possibilities. While at present apprentice school instruction is generally given to only the boys in the mechanical department, yet the author believes that within the next decade, a broader scope of railway education will be developed in which practically all skilled employees will be under instruction which relates directly to their crafts.

However, the shop apprentice boy is at present quite a large enough problem. Since an apprentice is a boy, he is essentially an individual. All schemes of scientific management that have so far been developed for him have failed because of this fact. Apprentices may be required to pass standard examinations before entering their apprenticeship, they may be impartially and systematically corrected and graded by their foreman and by their instructor, they may be disciplined; yet the apprentice is still a boy. This nature requires that he be led. Each characteristic should be studied by his foreman and instructor and the knowledge and sympathy thus established used to lead the apprentice toward good and intelligent workmanship rather than to attempt to accomplish it by the use of an inflexible rod of discipline. When drawn along by the "different individuality" links he cannot swerve to one side but when pushed ahead he may suddenly swing out of the line of applied force. Every means should be used to find these qualities; his parents, associates and friends should be tactfully consulted with this one purpose in view.

Discipline is at times necessary and from the standpoint of the foreman and instructor it is becoming more necessary each year. There was a time, fast disappearing, when an apprentice was automatically disciplined by his fellow workmen. Before the days of apprentice schools and systematic management, the average journeyman considered himself an instructor in the mysterious art of his trade, the ritual consisting of knocks, jokes and ridicule. Very few books were written concerning his craft and how, the mechanic asked, could a boy learn anything unless he were impressively talked to over a vise or deep in a pit? This period has, however, about passed, and the journeyman now feels that it is the company's work to train the boys. Discipline should, therefore, also be administered by the company, but care must be exercised by their agent in its administration. He should be a man who is intimately acquainted with the boys and with the men, he should know each little peculiarity of his boys, their weaknesses and their ambitions. He should have the respect of the journeymen and the liking of the apprentices; he should be recognized as the source of grievance adjustment, and the company's friendly advisor for the boys. In short, he should be intelligently sympathetic, yet impartial and just. Thus armed, the agent is properly equipped to administer discipline.

In both shop and classroom instruction the foreman and the instructor should work together to bring home to the boy the prime principle of importance and thoroughness. It is a lamentable fact that at least three-fourths of the apprentice applicants who have been more or less educated in the public schools, have little knowledge of the principles underlying the studies in which they have been educated. Explain everything clearly; do not leave a boy in doubt regarding any operation or problem. Everything about the shop has a reasonable explanation, and it is essential to future advancement that the reason, not merely the "theory," be understood by the apprentice. By diagrams, and examples, if necessary, show just why a square foot is not a linear foot, and why it is a measurement of area. It is not necessary that explanatory titles be given to each branch of study,

but starting with the elementary principles of the work, the entire study should be fabricated into a structure of practical working knowledge. Create within the apprentice first a love of principle, then teach him the importance of accuracy, and finally develop speed. The function of the apprentice department is specific, yet general, for its influence often pervades the entire shop. Each apprentice system is a local one in detail, inasmuch as it must conform to the local conditions. No text has ever been prepared which successfully deals with the entire subject, for each apprentice is a boy on his own street.

### DEVICES FOR SHOP USE

BY LeROY SMITH

MAGNETIC OLD MAN

The magnetic old man shown in Fig. 1 is made up of coils of an automatic motor starter, which had been discarded, into a form suitable for serving as a support for a small electric or air drill used for drilling telltale holes in staybolts in the boiler. The one shown is for use at 220 volts, direct current, and works best when the coils are in a vertical position.

to bring the forge up to a convenient height for the operator. The furnace is made of  $\frac{1}{8}$ -in. boiler plate and has a wind guard extending half way around it. A screen of  $\frac{1}{2}$ -in. boiler plate is placed in the bottom of the furnace through which compressed

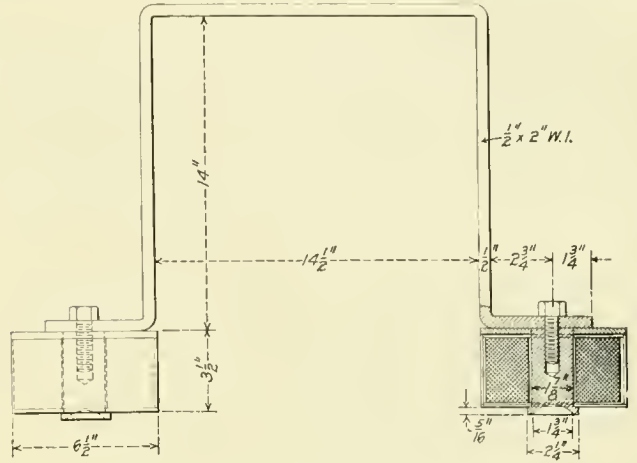

Fig. 1—Old Man Held in Place Magnetically

### PORTABLE RIVET FORGE

A substantial portable rivet forge that may be made in al-

air is blown, giving the necessary draft to the fire. The air is taken in through the  $\frac{3}{4}$ -in. hose connection, as shown in Fig. 3

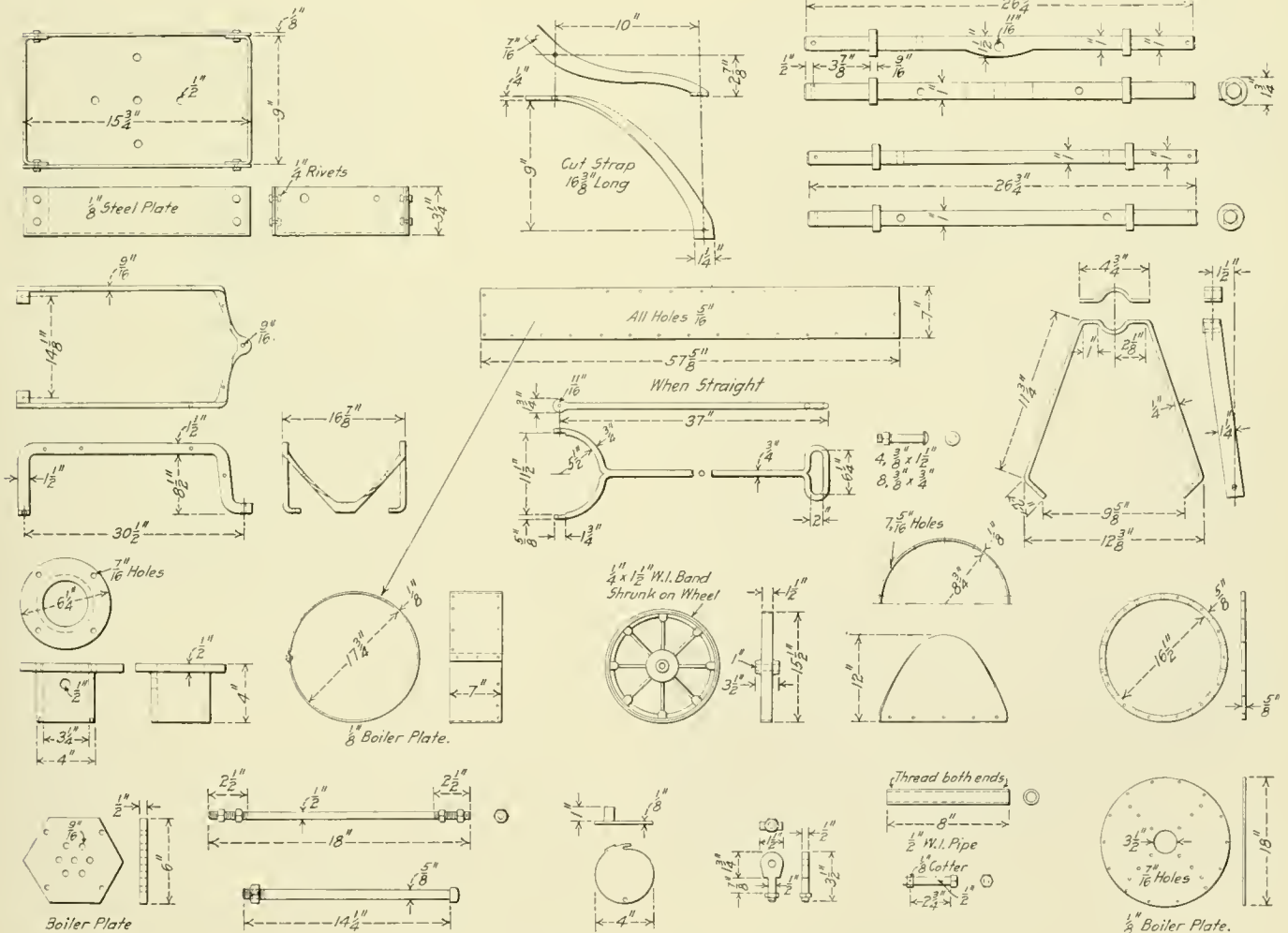

Fig. 2—Details of Portable Rivet Forge

most any railway shop is shown in Figs. 2 and 3. The wheels are 15 1/2 in. in diameter and the framework is so designed as

and regulated by a 1/2-in. stop cock. A pan 9 in. wide x 15 1/2 in. long x 3 1/4 in. high, made of 1/8-in. steel plate, is fastened to



the frame of the forge for carrying a quantity of cold rivets for the work at hand. There are five 1/2-in. holes drilled in the bottom to allow any water that may fall in the pan to drain

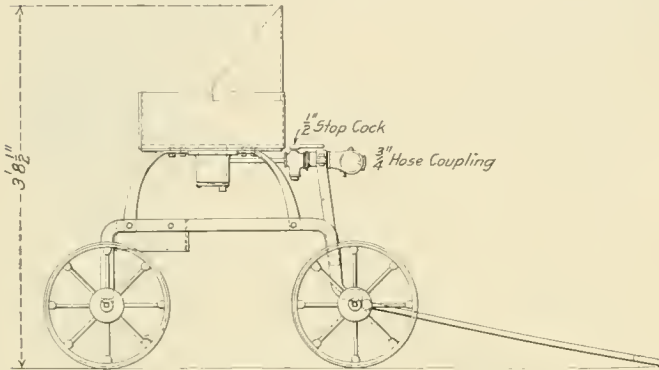
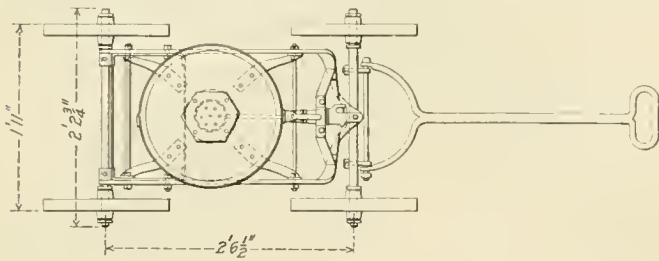

Fig. 3—Portable Rivet Forge

out. The working drawings and details are clearly shown in the illustrations.

### ROUNDHOUSE TEST RACK FOR EXAMINING LUBRICATORS

BY F. W. BENTLEY, JR.

Machinist, Butler Shops, Chicago & North Western, Milwaukee, Wis.

A great deal of the running repair and overhauling work done on lubricators at roundhouse points is work about which the repairman is forced to draw his own conclusions as to the

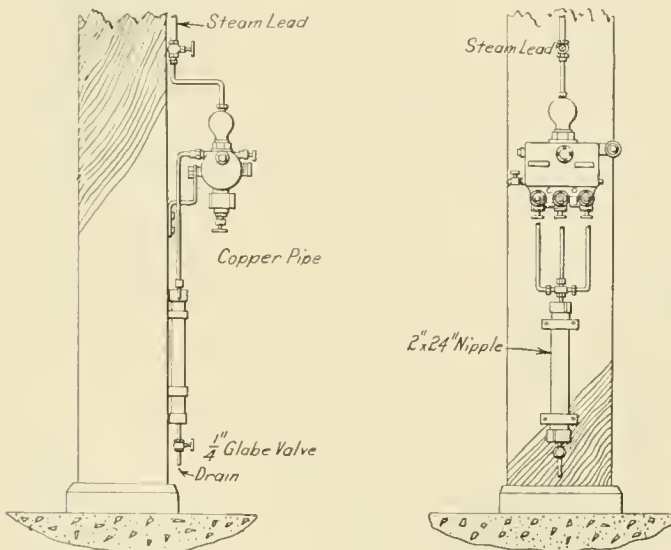

Rack for Testing Lubricators in the Roundhouse

exact nature of the defects. This is for the most part due to the fact that the opportunity for examining the lubricator generally arrives after the locomotive has been housed and cooled down.

The illustration shows a simple test rack which can be placed on any convenient roof support or post of the roundhouse.

Steam can be obtained from a tap in the blower pipe which generally extends down the side of the post. With this arrangement the lubricators can be tested under nearly the same conditions as those under which they operate on the locomotive, and after an overhauling will reveal any leaking joints which may not have been properly or securely tightened; the condition of the feed nozzles, reducing plugs, gaskets, etc., can be ascertained before applying the lubricator to the locomotive.

### TOOL FOR SETTING BOILER COURSE SHEETS

BY PAUL R. DUFFEY

In large locomotive boiler repair shops the setting of new boiler course sheets cannot be done without special forming devices. The tool shown in the drawing has been found to be very useful in this connection. The male die is inserted in the top of a press and the female die in the bed or plate.

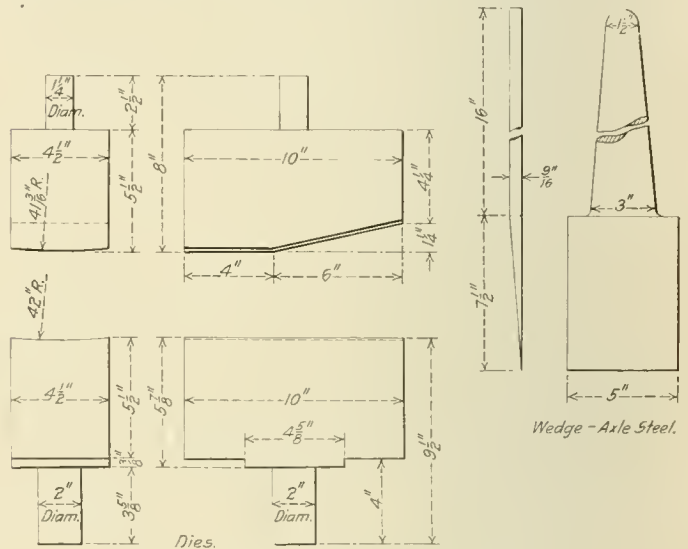

Tool Used in Setting Boiler Course Sheets

The sheet is placed between the two dies and the wedge set in the proper distance, quickly and accurately giving the sheet the proper set. The dies and wedge should be made of a good grade of axle steel in order to successfully hold their shape under the required work. All of the parts should be machine finished.

REFRIGERATOR CAR CONSTRUCTION. During the past three years 38,770 refrigerator cars were built by the private car lines and the railroads. The capacities of 7,000 of these were not obtainable. Of the rest, 3.3 per cent were of less than 60,000 lb. capacity, 57 per cent were of 60,000 lb. capacity, 8.2 per cent were of 70,000 lb. capacity, 25 per cent were of 80,000 lb. capacity, and 6.5 per cent were of 90,000 lb. capacity. Of the total of 38,770 cars, 21,941 were equipped with steel underframes; 12,448 were equipped with friction draft gear; 6,778 were equipped with spring draft gear; 3,932 were of all-wood construction, and 505 were of steel frame and underframe construction. The following table, giving the percentages of those cars, of which information could be obtained, that were constructed with steel underframes, friction draft gears, spring draft gears, and of all wood, shows clearly the recent tendencies in construction:

	1911	1912	1913
Steel underframe	44.3 per cent.	51.7 per cent.	79.4 per cent.
Friction draft gear	38.3 per cent.	8.8 per cent.	89.2 per cent.
Spring draft gear	22.4 per cent.	21 per cent.	0.2 per cent.
All wood construction	29.7 per cent.	3.2 per cent.	0.2 per cent.

—Railway Age Gazette.

# NEW DEVICES

## HIGH SPEED DRILL

A high speed drilling machine which has a capacity for driving 2½-in. diameter high speed drills in solid steel has been developed by Baker Brothers, Toledo, Ohio, and is shown in the accompanying illustration. This machine is massive and powerful throughout and is provided with a full range of speeds and feeds for rapid work.

Changes are obtained through hardened sliding gears mounted on ball bearings which give high efficiency and great durability. With the driving pulley running at 500 r. p. m. there are six speeds to the spindle, as follows: 500, 369, 258, 179, 130, 92½. Any one of these speeds may be obtained instantly by means of sliding gears controlled by one lever within easy reach of the

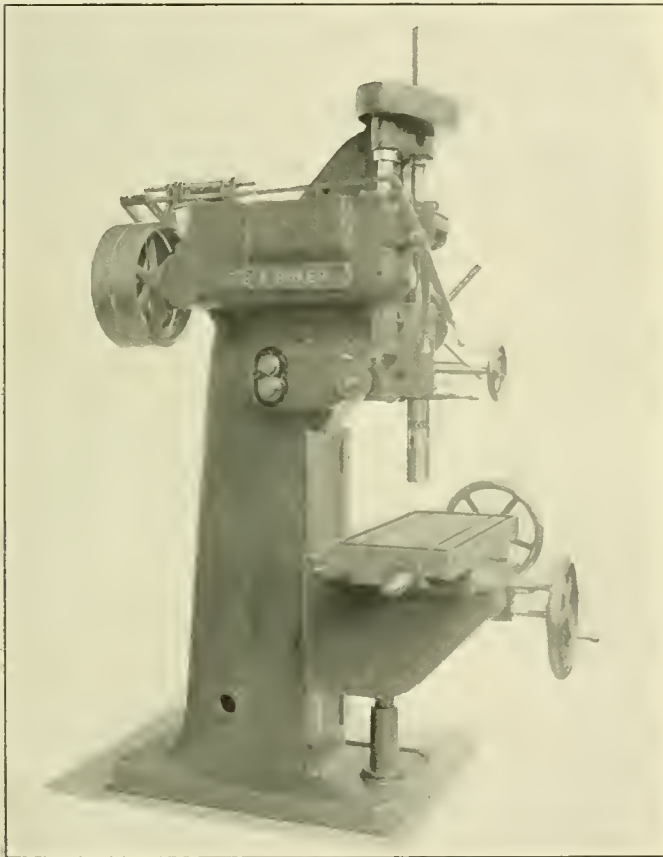

Ball Bearing High Speed Drill.

operator. The machine is so arranged that there are no idler gears running at any time and only one pair is in mesh at a time.

The gears in the train, except the large top driving gear, are of steel, oil treated and hardened. They run in baths of oil and are protected by suitable guards. The driving shafts are mounted on high duty radial bearings enclosed in oil tight cases.

The spindle is made of high carbon hammered steel and the thrust is taken on high duty ball bearings. The spindle has a diameter of two inches at the driving end and three and one-quarter inches at the nose. It has a vertical feed of 16 in. and is equipped with a depth stop. Twelve changes of feed per revolution of the spindle are provided, ranging between .006 and .032 in.

The machine illustrated has a compound table which is provided with screw adjustments in all directions. Micrometer collars are provided on the in and out and the cross movements and it is not necessary to lock the table in position after an adjustment has been made. This table is 16 in. by 36 in. and the maximum distance from the end of the spindle to the top of the table is 25 in. The table has 16 in. vertical travel. A distance of 12¼ in. from the center of the spindle to the face of the column is provided.

A belt drive from either a shaft or a motor can be used. In the latter case a 10 horsepower motor is specified. When shaft driven a 3-in. belt running on an 18-in. diameter pulley at 475 revolutions a minute is recommended in the specifications.

## AIR HOSE PROTECTOR

The illustrations show a new design of air hose protector that is practically indestructible and may be applied easily to any air brake hose. It is designed to prevent the hose being

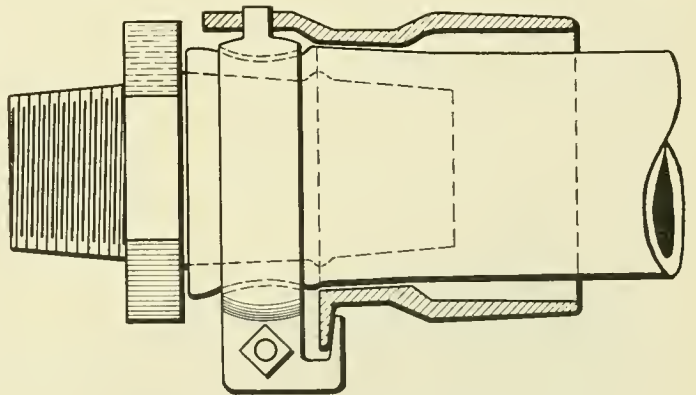

Malleable Iron Protector for Air Hose

cut at the nipple, and at the same time to not interfere with the flexibility of the hose, the protector being hinged to the clamp, as shown, for that specific purpose. The protector is

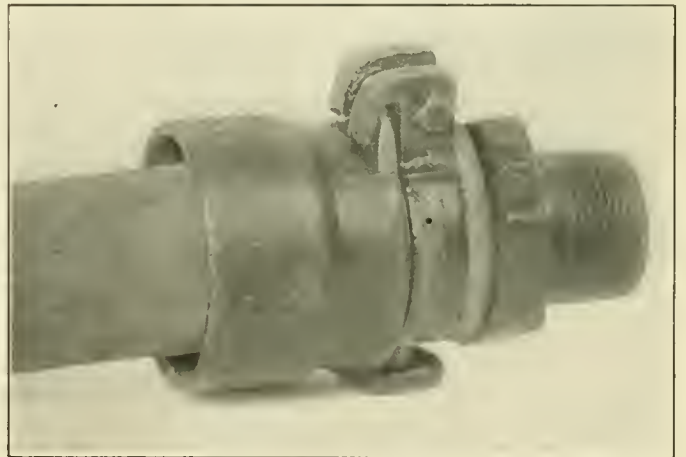

Peffers Air Hose Protector

made in a bell shape to increase the range of flexibility, and to also bring the protector away from the hose at the extreme end of the nipple, thereby preventing any possibility of cutting



the hose. As will be noticed in the cross section the restricted portion of the protector terminates well above the end of the nipple so that any blow received by the protector will be transmitted to the hose above the end of the nipple.

Both the protector and the clamp are made of malleable iron. The protector is held in position by the clamp, which has a pin on one side and fingers on each side of the break in the clamp. The fingers extend underneath the lip on the protector, the lip being of such a width that when the clamp bolt is removed from the clamp the protector may be easily removed. It is claimed that the protector will last almost indefinitely, under fair usage, and that the clamp may be used over several times. This hose protector was invented by A. Roy Peffers, 474 South La Salle street, Aurora, Ill., who is also handling the general sales.

### ECONOMY ENGINE TRUCK

An improvement in engine trucks, adaptable to either the two or four-wheel types, has been developed by the Economy Devices Corporation, 30 Church-street, New York, and is shown in the accompanying illustrations. This employs a new type of centering arrangement, and also a new form for the truck frame and pedestal.

The development of this truck was brought about by the knowledge that the very large locomotives with wheel bases of about 34 ft. have so great a bolster displacement at the front truck that the usual designs are unsatisfactory both in guiding qualities and in preventing flange wear on the drivers. This is true because a bolster displacement of as much as 4½ in. is frequently required for this length of wheel base and the three

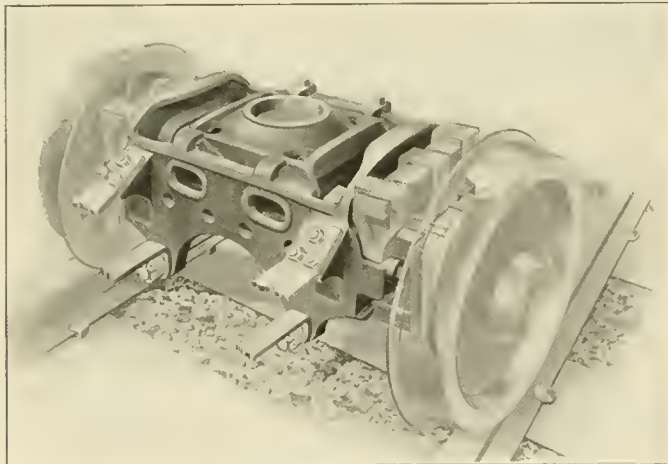

General View of the Economy Locomotive Front Truck

point hangers generally used must have an excessive length in proportion to the spread of the hanger pins, thereby reducing the initial resistance of the bolster, to the impairment of the guiding qualities. The evidence of this is seen in the greatly increased wear on the driving wheel flanges of these long locomotives. This form of truck is shown in the upper view of one of the illustrations and the design that has now been developed is shown below it. The latter is called a "constant resistance" centering arrangement and the bolster rests on the points of rockers of the form shown. Upon the displacement of the center pin in either direction the contact point moves on the curved surface of the rockers and the inclined plane to the bolster and thus maintains a practically constant ratio between *X* and *Y*, or a constant lateral resistance. It will be seen that this ratio in the three point hangers, shown above, increases very rapidly as the center pin is displaced laterally.

At the point of greatest displacement, which occurs when the locomotive is going around sharp curves or turnouts, especially

on the light tracks usually found in engine terminals, the diminished resistance offered by this new type of support is particularly appreciated. Furthermore, the increased guiding effort on a truck on a tangent, or on curves found on the main line, which results from the larger ratio of *X* to *Y* that can be obtained in the central position, should have a striking effect in the form of diminished wear of driving wheel flanges.

The frame and pedestals of the truck are cast in one piece and are so arranged that semi-elliptic springs of a good length

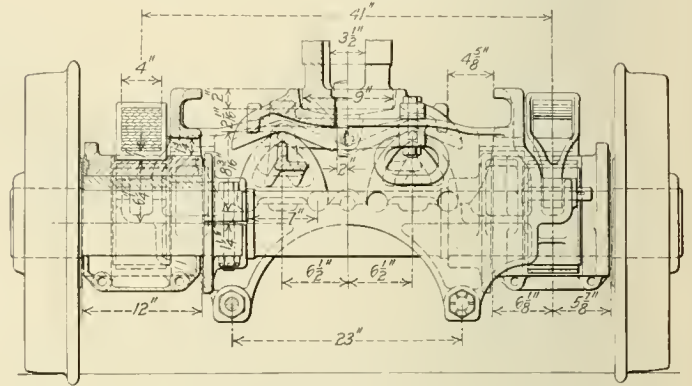

General Arrangement of the Economy Two-Wheel Engine Truck

can be used while still affording ample clearance under the locomotive frame. It will be noticed that the springs are supported by hangers directly from the main frame. Furthermore, advantage has been taken in this design to so locate the pedestal tie bars that they come inside the journal boxes, thus making provision for journal box cellars of a depth suitable to insure proper lubrication. The arrangement also facilitates the removal and replacement of cellars while packing.

The pedestals have been provided with pressed steel shoes of a special design, held in position by vertical flanges on the

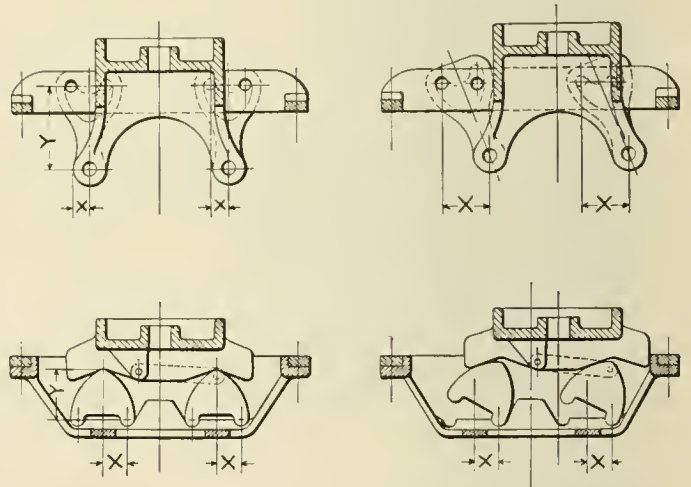

The Upper Views Show the Usual Three Point Hangers, and the Lower the Economy Arrangement for Engine Trucks

sides and with lips turned over the top and bottom. These can be quickly replaced when worn without dropping the wheels.

The design further includes cast iron axle collars secured to the axle inside of the journal boxes. These reduce hub wear and materially decrease the cost of maintenance.

SMALL ANTHRACITE SHIPMENTS IN JANUARY.—Shipments of anthracite coal during January, 1914, were 1,160,687 tons less than in January, 1913. The difference of over a million tons in production is due to the difference in the weather the first month of last year and this.

### LOW WATER ALARM

A recently developed type of low water alarm for boilers is shown in the illustrations. This alarm is the invention of E. J. Shearer and W. D. Anderson, Lordsburg, New Mex., and is designed for use on either locomotive or stationary boilers.

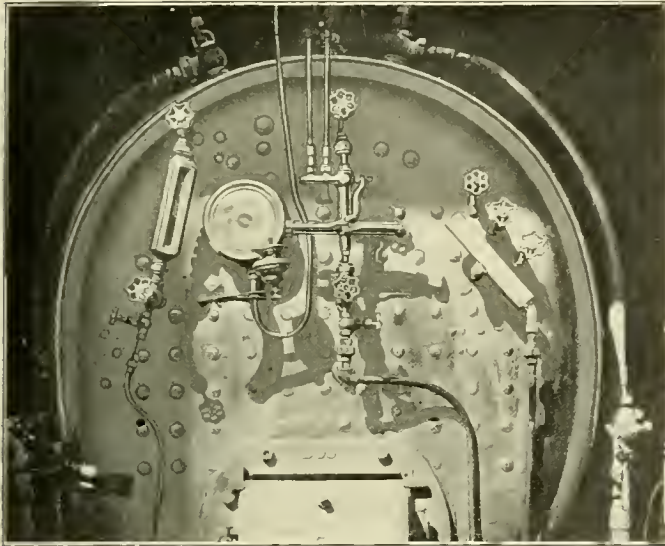

Low Water Alarm in Position on a Boiler

The device has a small valve that opens  $\frac{1}{8}$  in. and allows the whistle to blow. The cross pipes at the bottom are the expansion pipes that operate the lever which connects with the valve.

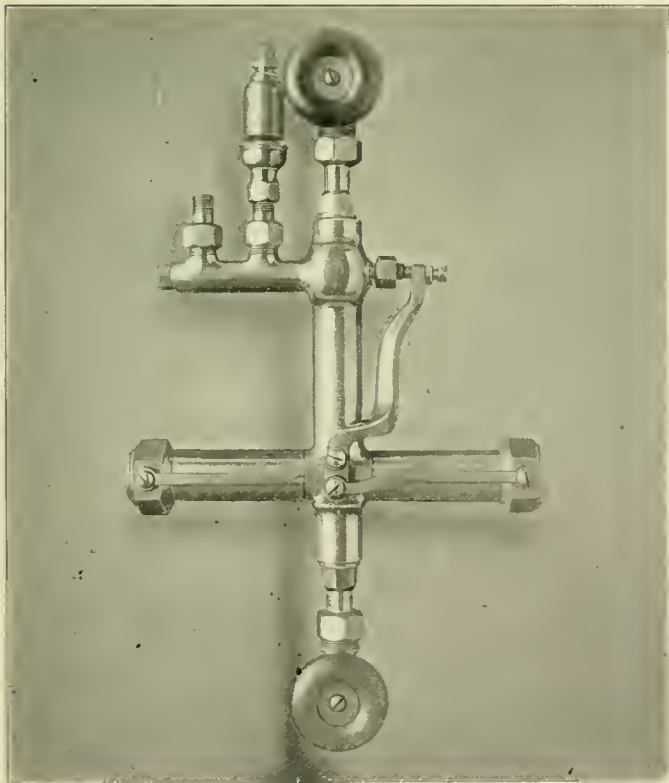

A Recently Developed Low Water Alarm

The alarm is placed on the boiler-head and set so that the cross pipes are the proper height from the bottom of the water glass. As the water becomes low in the boiler it also becomes low in the alarm. The steam follows the water, and

as soon as the water leaves the cross pipes at the bottom of the alarm, the steam enters from the top cock and causes the expansion which operates the lever that opens the whistle valve.

### JOURNAL COOLER

The hot box is always considered one of the necessary evils of railroad operation, but it will be generally admitted that there is much possibility of improvement in the methods of cooling journal boxes.

The B-J cooler, which is shown in the illustrations, was designed to overcome train delay. The cooler consists of a tank resting on two supports which are clamped to the journal

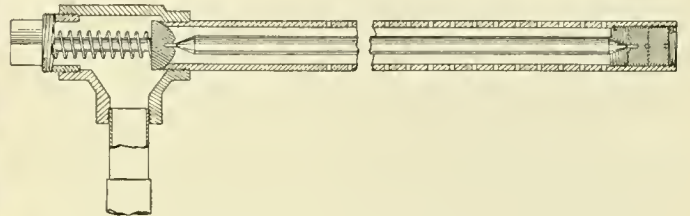

Thermostatic Valve Which Controls the Flow of the Water

box. Water from the tank is carried to the hot journal through a short hose and pipe connection which is controlled by an automatic valve. When a journal becomes heated the tank is clamped to the box and the nozzle inserted on the rising side of the journal so that the water will tend to be carried up under the brass. This nozzle sprays the water as needed the full length of the hot journal, cooling it gradually. When the nozzle is placed in the hot journal box, the thermostatic element shown in the line engraving expands in the direction of its length, forcing back the feed valve and allowing free flow of the cooling agent to the spray pipe. This brings about a gradual uniform cooling of the journal and brass. With the

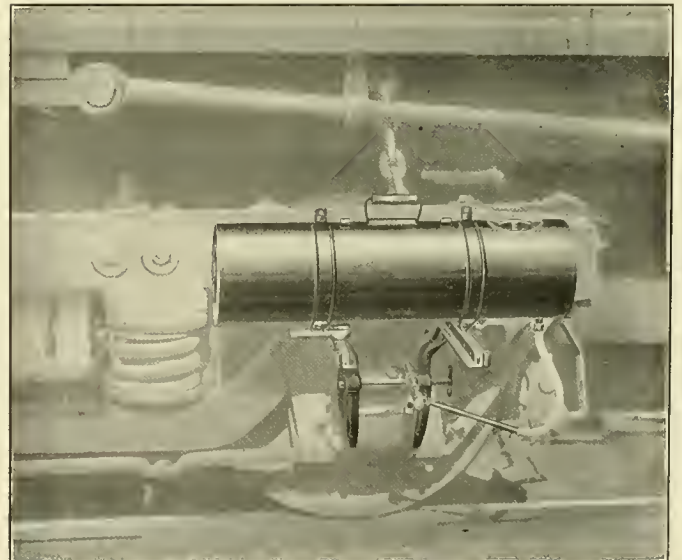

Cooler Applied to a Passenger Truck

cooling of the journal the thermostatic element gradually contracts, thereby reducing the flow until, when the box is at normal temperature the flow is practically stopped. It will thus be seen that the amount of water supplied to the journal is always proportionate to the degree to which the temperature of the journal is raised.

No running time need be lost in applying the cooler as it can be attached during a regular stop of two minutes. By feeding the water only as it is required there is no occasion to



stop the train in order to replenish the tank. Typical of the possibilities in actual service, the following is taken from a railway report:

After running 46 miles to the first stop of the train, the journal box was found to be heating. At the second stop, 30 miles further on, the heat was increasing and at the next stop, 15 miles further, the oil was boiling and splashing. The cooler, containing seven gallons of water, was then applied. At the next stop, 41 miles further on, the box was shown to be cooling, while at the next stop, 22 miles further on, the box had been cooled to almost normal running temperature and the brass was

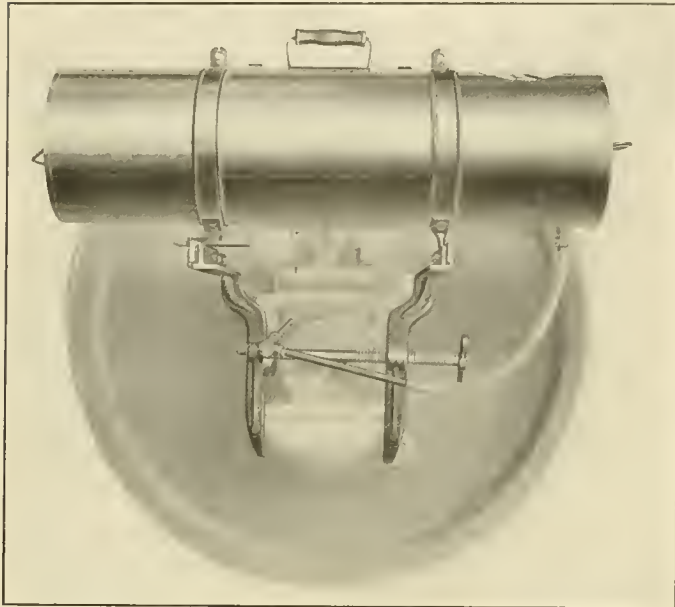

Method of Attaching the Cooler to a Journal Box

found to be in good condition. Five quarts of water was added to the cooler and the box was repacked. At the next stop, 77 miles further on, the box was found to be in good condition and there was little or no water passing through the thermostatic valve. The trip ended after another 60 miles, and the cooler was taken off, still containing a quantity of water which, when measured, showed that the journal had been cooled by using about three gallons.

This cooler is manufactured by the Transportation Utilities Company, 30 Church St., New York.

### A NOVEL FORM OF WRENCH

The Shaw wrench is made in one piece, bevel-jawed, and is designed for any work than can be done by stillson, monkey, alligator, or flat wrenches, and many classes of work for which special tools must be employed. As will be seen from the illus-

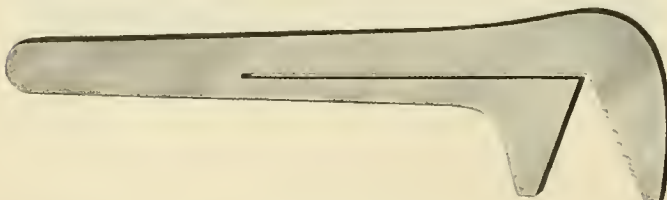

The Shaw Wrench

tration, the novel feature of this wrench is the spring, because of which, it is claimed, it will grip a steel rod or a round head bolt instantly, and cannot slip while in use. It requires no adjustment. The wrench is manufactured by the Shaw Propellor Company, Board of Trade building, Boston, Mass.

### PORTABLE GRINDER FOR PLANERS

The need for a device that will accurately grind the knives of planers and jointers without taking them from the tool has been recognized by users of wood-working machinery. Removing the knives and putting them back properly adjusted is a somewhat difficult task. It is often done hurriedly and improperly, resulting not only in poor work, but inefficient production. This is especially true of the thin, hard knives used on modern cylindrical head planers.

A portable grinder has recently been perfected by the Stockbridge Machine Company, Worcester, Mass., which meets this demand. This machine is electrically driven, will grind true, is adaptable to all makes and sizes of planers, is easily attached and is light enough to be easily carried from one machine to another.

As will be seen in the illustration, the motor is mounted in the grinder head. Current is taken from an ordinary lamp socket. The saddle is attached a split nut engaging the feed screw which lies along the top of the bridge. The saddle can be fed the length of the bridge in either direction and at any speed desired. The bridge is supported at the ends, or any point most convenient, by two angular brackets which are bolted to the machine bed, holding the grinder rigid. The grinding wheel, which is cup-faced, can be raised or lowered by a thumb-

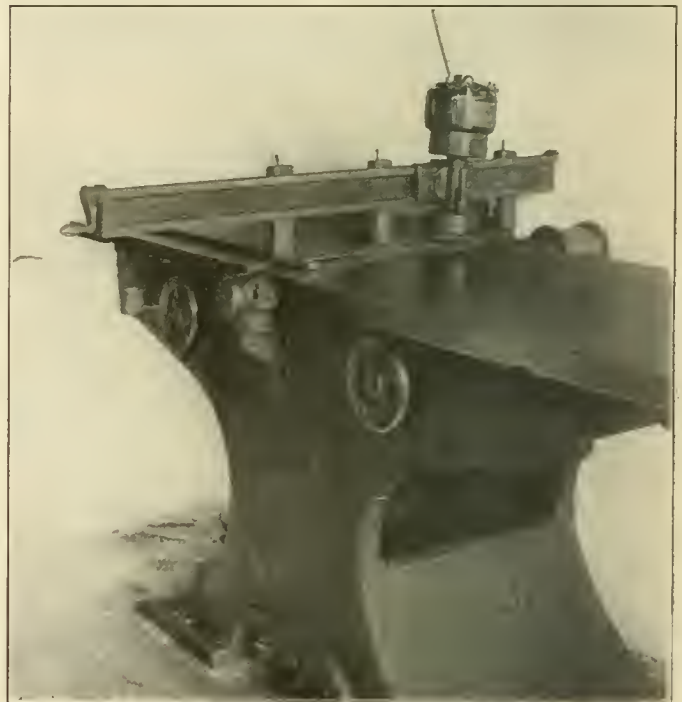

Portable Electric Grinder in Operation

screw and can be set to grind the required amount from the knives, automatically feeding itself to a positive stop. In the grinding wheel there is a tension spring which maintains a constant and uniform pressure on the wheel, thus eliminating all danger of overheating and burning the knives.

The grinder head is pivoted at the center and can be tilted to either side of the perpendicular, and is held in place against a stop giving the same angle on either side. The tilted head gives a concaved cutting edge to the knives. A positive stop holds each knife in exactly the same relative position to the wheel.

THIRD CLASS SLEEPING CARS.—The advisability of the adoption of third class sleepers has recently come up in Germany. Experiments with such cars have already been made in Norway and Sweden.

## PYROMETER FOR SUPERHEATER LOCOMOTIVES

While it is true that remarkable economy results from the operation of locomotives equipped with superheaters, even when the best practices are not followed in handling them, the highest economy is obtained when the engines are given proper attention at the terminals and are carefully handled on the road. Whether the engines are receiving the care that they should at the roundhouses and are being efficiently operated on the road is best determined by the amount of superheat produced.

Recognizing the need of an indicator whereby the engineer could, at all times, be informed as to the temperature of the steam in the steam chest, attempts were made to find a suitable pyrometer for this purpose. Several instruments of both the pressure and electrical types were tested and found to be unsuited to the severe conditions under which they would have to operate. In order to get a satisfactory instrument for this purpose it was necessary to develop one that would meet the requirements established by the service in which it must operate. The conditions to be met were those of excessive vibration, varying temperatures and atmospheric conditions, as well as the rough handling to which devices on locomotives are subject. To meet these conditions required delicacy of adjustment and freedom of operation, combined with increased sizes of parts and durability of construction.

An instrument which has been developed to a satisfactory state is manufactured for the Locomotive Superheater Company, 30 Church street, New York, and is of the electrical type, consisting of thermo couples, constructed and arranged in accordance with the Bristol system. The cold end is located in the boiler, in the saturated steam, and the hot end in the steam chest, directly in the flow of the superheated steam. Electrical connections are established to an indicator of the milli-voltmeter type, located on the gage bracket in the cab.

The ends of the couples are so located that a variation of the outside temperature has practically no effect upon them. The

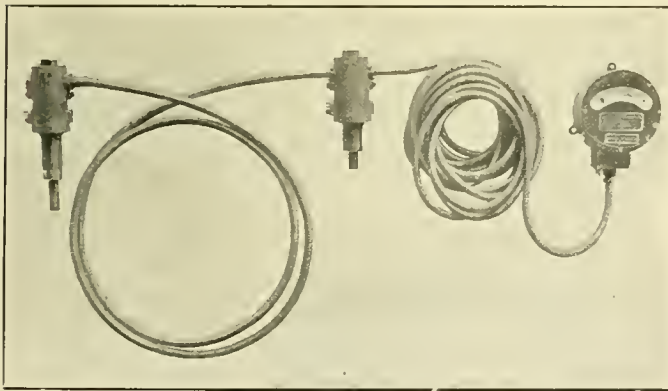

Assembled Parts of the Pyrometer Apparatus

cold end of the couple, placed in the boiler in the saturated steam, is subject to only the slight variation in temperature due to the variation of the steam pressure, which does not vary more than a few pounds when the locomotive is in operation. The hot end of the couple, placed in the steam chest in the flow of superheated steam, is subjected to a range of temperatures from that of saturated steam to about 650 deg. The difference in electromotive force generated by the hot and cold ends of the couples is read directly in degrees Fahrenheit on the dial in the cab.

The electrical lead and extension between the couples and the instrument are designed to provide flexibility and the least amount of deterioration resulting from handling and bending. They are insulated with a specially prepared composition, which is affected by neither moisture nor temperature, and they are

finally enclosed within a flexible bronze armor which prevents them from being bruised by substances falling on them.

The instrument itself is of the milli-voltmeter, double-jeweled Weston type, the movement having been very carefully designed from a standpoint of accuracy and lightness, in order that it may be depended upon to register accurately the extremely low electromotive force generated by the thermo couples. At the same time its construction is substantial enough to withstand the vibration and the temperature conditions to which it is subjected. The dial of the instrument is graduated to read directly in degrees Fahrenheit, and has a range of from 250 deg. to 750 deg. The pointer and graduations are carefully selected with

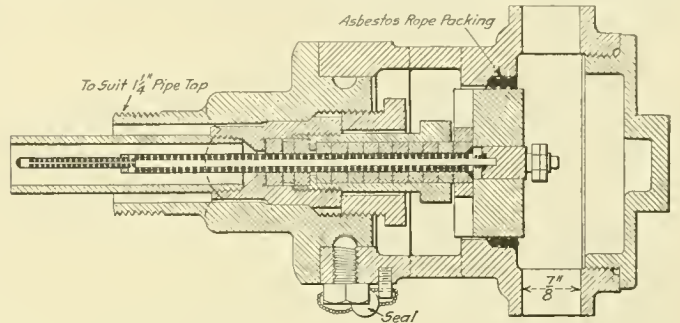

Section Through the Saturated Steam Fixture

the purpose in view of making them distinctly visible at all times, under the light conditions that prevail in a locomotive cab.

When a superheater locomotive is standing or drifting with the throttle closed, there is, of course, no superheat being obtained, and the indicating hand of the pyrometer instrument in the cab will be at the left hand side of the dial, reading between 350 and 390 deg., assuming that the boiler pressure carried is 200 lb. or less. As the throttle is opened and the engine starts to work, steam from the boiler passes through the superheater pipes and the superheating process begins. As the engine starts, the pointer will move from left to right on the scale, showing an increased temperature in the steam chest and as the engine is worked harder the superheat added to the steam increases until, under average conditions, the indicator registers between 600 and 650 deg.

When the pyrometer operates in this manner, it is an indication to the engineman that the locomotive is being handled so that the maximum saving that the superheater makes available is being obtained. If it fails to operate in this manner, it shows him that either the locomotive is not being operated to produce the best results or that it has not received the proper attention at the roundhouse.

## SOCKET WASHER FOR GRAB IRONS

In applying ladders or grab irons to cars, it is often necessary to place a block or cradle between the siding and the lining in order to allow the bolt to be drawn up tight and

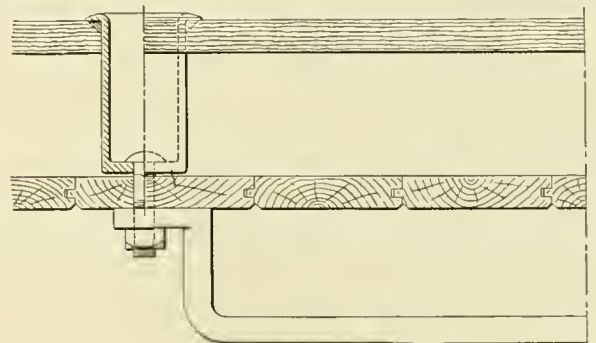

Socket Washer Used in Applying a Grab Iron



make the ladder or grab iron secure. In many cases where grab irons are applied to existing cars, it is necessary to remove either the siding or the lining, apply a block, and then apply new siding or lining in place of that removed. In order to facilitate and cheapen the application of grab irons and ladders, there has been developed by the Wine Railway Appliance Company, Toledo, Ohio, a socket washer which, it is claimed, is easily applied and makes the grab iron or ladder much more secure than the use of a block. By making the washer about  $\frac{1}{8}$  in. short, as there is only  $\frac{3}{4}$  in. thickness of wood to shrink and wear, the device when properly applied should remain firm and tight indefinitely. The washer can be designed in such a manner that the bolt may be removed and replaced from the outside of the car.

## HEAVY DUTY RADIAL DRILL

The Fosdick Machine Tool Company, Cincinnati, Ohio, has recently perfected a new design of 3 ft. heavy duty box column radial drill, which is shown in the accompanying illustration. This machine, with the exception of the column, arm, and table, is the same design as the round column machine, built by the same company, which was fully illustrated and described on page 619 of the November, 1913, issue of this journal.

Adaptability to a large variation in the range of work it is capable of performing, is the special feature of this new machine. Correct feeds and speeds are available for all sizes of

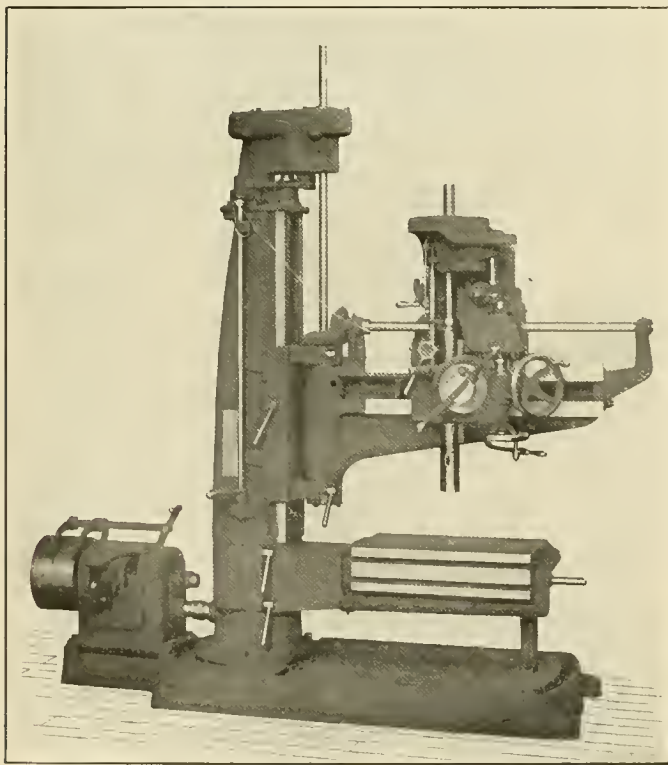

Three-Foot Box Column Radial Drill

drills from a  $\frac{5}{16}$  in. carbon steel drill to a 3 in. diameter high speed steel drill. A complete list of the proper speeds and feeds for different drilling conditions are given on a metal plate conveniently attached to the column of the machine.

For heavy drilling or tapping in steel, an oil channel has been cast around the base, which drains to a large reservoir under the column, where a pump and piping may be attached. For the smaller drilling and tapping operations a liberal channel has been provided around the table, which drains to one corner, under which any receptacle for the lubricant may be placed, thus avoiding the use of a pump and return piping.

Special attention has been given to the design of the column and the arm. The former is a heavy, one piece box section, internally ribbed, and the latter is of the pipe and beam section, which has proved to be a very rigid combination for this work. The construction permits a long saddle bearing to be securely gibbed to the wide flat space of the column, making sagging of the arm impossible, and provides a means for taking up any amount of wear, as well as bringing the binding levers close to the operator.

The arm rests on a special ball bearing which reduces the effort required to swing from one position to another and allows rapid setting. The elevating screw, which raises and lowers the arm by power, is suspended on a ball bearing and the handle is placed in a convenient position. Safety trips for both extremes are provided. A maximum distance from the base to the end of the spindle of  $52\frac{1}{2}$  in., and minimum distance of 16 in., is allowed.

There are five changes of feed provided in the head, all made with a single lever and without stopping the machine. These give speeds from .007 to .031 in. per revolution.

The speed box gives six changes of speed all made by a single lever. The back gears are on the head and give three changes without stopping the machine. There are thus 18 different speeds of the spindle, ranging between 25 and 400 r. p. m., that can be used. A positive overtake keeps the machine running at a reduced speed and avoids shock when making changes. The spindle has a traverse of 12 in., and the head has a traverse on the arm for a distance of  $23\frac{1}{4}$  in. The maximum distance from the spindle to the column at the base is 39 in.

All gears throughout the machine are enclosed, but provision is made for easy accessibility in case it is required. The bearings are made of a special phosphor bronze.

The tapping reverse functions are very simple and powerful and adjustable from the outside for any amount of wear. The lubrication system is complete and nearly all of the gears run in oil. The machine has a net weight of 4,200 lb.

## ADJUSTABLE SPACING COLLAR

A collar designed primarily for use in milling machine manufacturing operations where two or more milling cutters on the same arbor must be spaced an exact distance apart, is shown in the accompanying illustration. When it is necessary to grind the side of the teeth of milling cutters, the distance between the faces is changed, and in order to maintain the proper width on the piece being machined, compensation must be made in

some way for the amount ground from the cutter. This is sometimes accomplished by carrying in stock an assorted lot of solid spacing collars of varying lengths, and if the exact size cannot be found, provision must be made for grinding

off a solid collar that is too long or shimming up one that is too short.

The collar illustrated, which is sold by Scully-Jones & Co., Railway Exchange, Chicago, is so designed that the thickness can be changed to a total of .024 in. This total is divided into twelve spaces of .002 in. each. The adjustment is quickly made and after each adjustment it is, in effect, a solid collar.

Reference to the illustration will show the construction which permits this varying of lengths. In addition to its use as a spacing for milling cutters it can also be used for other purposes where solidity and adjustability are desired.



An Adjustable Spacing Collar for Milling Cutters

# NEWS DEPARTMENT

The New York Central has recently completed an all-steel dining car at the West Albany shops, and four more cars of the same type are now under construction there.

R. C. Richards, chairman of the central safety committee of the Chicago & North Western, has been appointed chairman of a committee of the City Club of Chicago that proposes to conduct a campaign against trespassing on railway property.

The "safety first" movement is to be introduced on the Canadian Government Railways. F. P. Gutelius, general manager, Moncton, announces the appointment of J. E. Long, safety engineer, as the head of the department. He is to organize committees and hold meetings.

Professors from the Pennsylvania State College are to give lectures to the apprentices in the shops of the Pennsylvania Railroad at Altoona. Lectures will be given twice a week to members of the fourth year class. Apprentices will have the option of joining the lecture class or not; but having once joined, attendance will be compulsory.

Southbound passenger train No. 1 of the Queen & Crescent was stopped by robbers near Attalla, Ala., on the night of February 19, and all of the registered mail was taken from the mail car. One postal clerk who resisted the robbers was stabbed. The mail and express cars were detached from the train and run a considerable distance forward; and the passengers were not molested.

Dennis McGuire, a locomotive engineman on the Lehigh Valley, has been granted a month's vacation with pay and an honor button for having brought forward a new safety-first idea. He suggested to Superintendent Charles Shea that engine inspectors be equipped with magnifying glasses, so that they might more readily detect cracks and flaws on axles and other mechanism. The suggestion was at once adopted and McGuire received his reward.

In 1910, the Southern Pacific, Pacific system, handled about six and a half million pieces of baggage; in 1911, it handled six and a quarter million; and in 1912, it handled almost seven and a quarter million. For the three years, the total was 19,831,248. Out of this number, only 180 pieces went astray—an average of 60 pieces a year. And in many cases, baggage would not have gone astray had passengers themselves checked their belongings, had them rechecked, when necessary, or changed the checking when they changed their own destination en route.

The Pennsylvania Railroad has now on its pension rolls 4,037 employees, of whom 27 are women. During the past 13 years the total number of employees placed on the pension rolls has been 7,800. The payments have aggregated \$9,500,500. This includes the lines both east and west of Pittsburgh. The company has issued a circular in which there is a large picture taken at a recent luncheon given to the veterans of the road by the Railroad Young Men's Christian Association of West Philadelphia. At this luncheon there were present 150 retired employees, of whom 48 had been in the service of the company for 48 years or more, and of whom 89 had served in the army during the Civil War.

The army of Pennsylvania Railroad Company employees in the Altoona district, numbering approximately 21,000, with the dependent members of their families, will herald with delight the news that the Pennsylvania Railroad will issue passes in the same manner as in 1913. The thousands of workmen and members of their families have been awaiting the action

of the road on the pass question since the Pennsylvania State Public Service Commission issued its edict that the granting of passes to employees and dependent members of their families by the company would not be considered as a violation of the law. General Manager S. C. Long has issued a notice to the effect that the Public Service Commission's ruling will be accepted as affording protection against exaction of penalties for the issuance of passes to dependent members of the families of officers and employees, and the notice of November 29 announcing discontinuance of passes is annulled.—*Altoona Tribune*.

## A CORRECTION

The name of the publishers of the book on Working Drawings of Machinery, noticed in the February issue, page 60, was given incorrectly. It should have been John Wiley & Sons, Inc., 432 Fourth avenue, New York.

## A LESSON IN CIPHERS

The Baltimore & Ohio has 2,000 offices, and the stationer, in a circular enjoining economy, says that stationery and printing cost the road in 1913 about \$500,000. The offices used in that year 700,000 lead pencils, 1,000,000 pens, 23,000,000 pins, 18,000,000 envelopes, 14,000,000 sheets of carbon paper, 23,000,000 second sheets, 11,000,000 rubber bands, 570,000 blotters, 2,500,000 letter fasteners, 2,000,000 file backs, 10,000 sponges, 3,300 rules and other office articles in proportion. These supplies cost \$60,000.

## COLD WEATHER INSTRUCTIONS

The Chicago & North Western has issued a bulletin to trainmen and others concerned giving instructions to be observed during cold weather. These include the following:

"Train and enginemen will bear in mind that in all cases speed must be sacrificed for safety. You will not be criticized for a failure to make time or for losing time under bad weather conditions. Bear in mind the great importance of proper observance of signals and proper flagging protection at all times and see that the rules in this respect are obeyed.

"Enginemen will be particular to use good judgment and run carefully, evenly, and safely during fogs, snow storms or stormy weather. Be particularly alert and careful at turn around sub-points and coal and water points. Observe speed restrictions and slow orders, and do not exceed scheduled time during extreme cold weather."

## ADVANCED COURSE IN ENGINEERING AT COLUMBIA UNIVERSITY

The trustees of Columbia University, New York, have recently determined to raise the requirements of admission to the schools of mines, of engineering and of chemistry and generally to elevate and strengthen the course in engineering and technical studies from and after July 1, 1914. These schools will then become advanced graduate schools to which students of any branch of engineering, who have had a suitable preliminary training at a scientific school or college, may come for the highest type of professional instruction and for training in methods of research. After July 1, 1915, the candidates for admission to these schools will be required to present evidence of such preliminary, general education as can ordinarily be had only by taking at least three years of study in a college or scientific school of high rank. This will place the schools of mines, engineering and chemistry on the same academic plane



as the present schools of law and medicine in Columbia University.

**B. & O. VETERANS**

Employees of the Baltimore & Ohio who have been twenty years or more in the service, are organizing a Veteran Employees' Association, with social and fraternal features. There is to be a branch on each division. Branches have been established in Philadelphia with 369 members, and in Baltimore with 279 members. Other branches will be organized in the near future at Brunswick, Md., with 180 members; Cumberland, Md., 100; Newark, Ohio, 100; Pittsburgh, 400; Grafton, W. Va., 100; Wheeling, W. Va., 75; Chicago Junction, Ohio, 125, and Garrett, Ind., 60. After these branches have been organized, the association will be extended to the Baltimore & Ohio Southwestern, the Cincinnati, Hamilton & Dayton and the Staten Island lines. One of the objects of the association is to lend assistance to the families of the members, should help be required, in event of death. The education of deceased members' children will be provided for and such other assistance as comes within the province of the association will be rendered. Membership is voluntary and the dues have been made nominal.

**STANDARD TIME BY WIRELESS TELEGRAPH**

The United States Naval Radio station at Arlington, opposite Washington (post office, Radio, Va.), sends out standard seventy-fifth meridian time every day, at noon and at 10 p. m.; and the same plan, with slight variations, is carried out at other stations—Key West, New Orleans, North Head, Eureka, San Diego and Mare Island. These time signals are sent primarily for the benefit of ships at sea, but we are informed that a number of jewelers in the eastern and the middle western states are making use of the signals. At this season of the year the time signals sent out from Arlington are received at stations on the Pacific coast. The Arlington station has a direct wire from the naval observatory, across the Potomac river, from which the signals are repeated by a relay which actuates the radio sending instrument. The time signals sent out from the stations on the Pacific coast come from the observatory at the Mare Island navy yard. The signals are sent in the same way that they are sent over telegraph wires, but they are kept up for five minutes, with the customary intermissions, beginning five minutes before the even hour. A small and simple radio installation is adequate to receive these signals.

**MEETINGS AND CONVENTIONS**

*Railway Storekeepers' Association.*—It has been decided by the executive committee that the eleventh annual convention of the association will be held at the Hotel Raleigh, Washington, D. C., May 18, 19 and 20, 1914.

*The American Railway Tool Foremen's Association.*—The American Railway Tool Foremen's Association will hold its sixth annual convention at the Hotel Sherman, Chicago, July 20-22, 1914. Among the subjects to be considered at the meetings are: The Standardization of Reamers for Locomotive Repair Shops; Machine Tool Repairs; Tool Room Grinding; Special Tools for Drilling; Reaming and Milling; Distribution of Tools for Shop Use; Dies for Cold Work, and Press and Special Punching.

*Western Railway Club.*—At the February meeting of the Western Railway Club a paper was presented on the Development of Milling Machines, by A. J. Baker, sales engineer for the Marshall & Huschart Machinery Company, Chicago. Mr. Baker spoke of the increasing use of milling machines in railway shops, and spoke of the marked improvement in milling machines during the past five years. Five years ago the maximum metal that could be removed by this machine per minute was 12 cu. in. of machine steel on a No. 5 Mechan-Cullom type, whereas today a machine of the same dimensions and cost will remove about 37½ cu. in. He went into the design of milling cutters at some length, clearly bringing out the importance of grinding these cutters properly.

*Railway Business Association.*—The Railway Business Association, a part of whose General Executive Committee are elected and a part appointed, has organized for 1914 with the following official roster: President, Geo. A. Post, New York; treasurer, Chas. A. Moore, New York; assistant treasurer, M. S. Clayton, New York; vice-presidents—A. M. Kittredge, Dayton, O.; W. E. Clow, Chicago; G. W. Simmons, St. Louis; S. P. Bush, Columbus, O.; Alba B. Johnson, Philadelphia; H. G. Prout, Pittsburgh; W. G. Pearce, New York. Executive Members—G. M. Basford, New York; J. C. Bradley, Buffalo; J. S. Coffin, New York; Walter H. Cottingham, Cleveland; O. H. Cutler, New York; Henry Elliot, East St. Louis; Irving T. Hartz, Chicago; F. T. Heffelfinger, Minneapolis; Robert P. Lamont, Chicago; W. B. Leach, Boston, Mass.; E. B. Leigh, Chicago; W. H. Marshall, New York; William McConway, Pittsburgh; A. H. Mulliken, Chicago; Rudolph Ortmann, Chicago; S. F. Pryor, St. Louis; W. W. Salmon, Rochester, N. Y.; Justus H. Schwacke, Philadelphia; Geo. T. Smith, Jersey City; James S. Stevenson, Detroit; H. H. Westinghouse, New York; W. W. Willits, Chicago.

*The following list gives names of secretaries, dates of next or regular meetings, and places of meeting of mechanical associations.*

- AIR BRAKE ASSOCIATION.—F. M. Nellis, 53 State St., Boston, Mass. Convention, May 5-8, 1914, Detroit, Mich.
- AMERICAN RAILWAY MASTER MECHANICS' ASSOC.—J. W. Taylor, Karpen building, Chicago. Convention, June 15-17, 1914, Atlantic City, N. J.
- AMERICAN RAILWAY TOOL FOREMEN'S ASSOCIATION.—A. R. Davis, Central of Georgia, Macon, Ga. Convention, July 20-22, 1914, Hotel Sherman, Chicago.
- AMERICAN SOCIETY FOR TESTING MATERIALS.—Prof. E. Marburg, University of Pennsylvania, Philadelphia, Pa.
- AMERICAN SOCIETY OF MECHANICAL ENGINEERS.—Calvin W. Rice, 29 W. Thirty-ninth St., New York.
- CAR FOREMEN'S ASSOCIATION OF CHICAGO.—Aaron Kline, 841 North Fiftieth Court, Chicago; 2d Monday in month, Chicago.
- CHIEF INTERCHANGE CAR INSPECTORS' AND CAR FOREMEN'S ASSOCIATION.—S. Skidmore, 946 Richmond street, Cincinnati, Ohio.
- INTERNATIONAL RAILWAY FUEL ASSOCIATION.—C. G. Hall, 922 McCormick building, Chicago. Convention, May 18-22, 1914, Chicago.
- INTERNATIONAL RAILWAY GENERAL FOREMEN'S ASSOCIATION.—William Hall, 829 W. Broadway, Winona, Minn. Convention, July 14-17, 1914, Hotel Sherman, Chicago.
- INTERNATIONAL RAILROAD MASTER BLACKSMITHS' ASSOCIATION.—A. L. Woodworth, Lima, Ohio. Convention, August 18-20, 1914, Milwaukee, Wis.
- MASTER BOILER MAKERS' ASSOCIATION.—Harry D. Vought, 95 Liberty St., New York. Convention, May 25-28, 1914, Philadelphia, Pa.
- MASTER CAR BUILDERS' ASSOCIATION.—J. W. Taylor, Karpen building, Chicago. Convention, June 10-12, 1914, Atlantic City, N. J.
- MASTER CAR AND LOCOMOTIVE PAINTERS' ASSOC. OF U. S. AND CANADA.—A. P. Dane, B. & M., Reading, Mass. Convention, September 8-11, 1914, Nashville, Tenn.
- RAILWAY STOREKEEPERS' ASSOCIATION.—J. P. Murphy, Box C, Collinwood, Ohio. Convention, May 18-20, 1914, Hotel Raleigh, Washington, D. C.
- TRAVELING ENGINEERS' ASSOCIATION.—W. O. Thompson, N. Y. C. & H. R., East Buffalo, N. Y. Convention, August, 1914, Chicago, Ill.

**RAILROAD CLUB MEETINGS**

Club.	Next Meeting.	Title of Paper.	Author.	Secretary.	Address.
Canadian .....	Mar. 10	Car Service .....	J. E. Duval .....	Jas. Powell .....	Room 13, Windsor Hotel, Montreal.
Central .....	Mar. 12	Rules of Interchange and Banquet .....	W. H. Sitterly .....	Harry D. Vought .....	95 Liberty St., New York.
New England .....	Mar. 10	Rules of Interchange and Annual Meeting .....	W. E. Cade, Jr. ....	W. E. Cade, Jr. ....	683 Atlantic Ave., Boston.
New York .....	Mar. 20	Annual Electrical Night .....	E. Huber Stokar .....	Harry D. Vought .....	95 Liberty St., New York.
Richmond .....	Mar. 9	Electric Light and Power .....	H. R. Palmer .....	F. O. Robinson .....	C. & O. Ry., Richmond, Va.
St. Louis .....	Mar. 13	Past and Present Railroadng .....	O. F. Bary .....	B. W. Frauenthal .....	Union Station, St. Louis, Mo.
Southern & S'w'rn .....	Mar. 19	Thermit Welding .....	Prof. L. E. Endsley .....	A. J. Merrill .....	218 Grant Bldg., Atlanta, Ga.
Western .....	Mar. 17	Tests of Chilled Cast Iron Wheels .....		Jos. W. Taylor .....	1112 Karpen Bldg., Chicago.

## PERSONALS

*It is our desire to make these columns cover as completely as possible all the changes that take place in the mechanical departments of the railways of this country, and we shall greatly appreciate any assistance that our readers may give us in helping to bring this about.*

### GENERAL

C. A. BINGAMAN has been appointed assistant engineer of motive power of the Philadelphia & Reading, with headquarters at Reading, Pa.

W. M. BOSWORTH has been appointed mechanical engineer of the Louisville & Nashville, with office at Louisville, Ky.

C. C. ELMES has been appointed assistant engineer of motive power of the Philadelphia & Reading, with headquarters at Reading, Pa.

E. B. HALL, whose appointment as assistant to the general superintendent of motive power and car departments of the Chicago & North Western, with headquarters at Chicago, was announced in the February issue, began railway work in July, 1889, with the Chicago & North Western, and has remained in the service of that road. Until August, 1892, he was machinist helper at Hawarden, Iowa, and then for six years was a fireman on the Northern Iowa and Western Iowa divisions. From October, 1898, to September, 1907, he was a locomotive engineer on the Sioux City division, and on the latter date was advanced to road foreman of engines of that division. He was master mechanic of the Northern Iowa and Sioux City divisions at Eagle Grove, Iowa, from March, 1910, to May, 1912, when he was transferred to the Wisconsin division in a similar capacity, with headquarters at Chicago, which position he held at the time of his recent promotion.

A. P. PRENDERGAST, formerly superintendent of motive power of the Baltimore & Ohio, at Baltimore, Md., has been appointed superintendent of machinery of the Texas & Pacific, with headquarters at Marshall, Tex., succeeding F. S. Anthony, resigned. After graduating from the public schools in West Virginia, Mr. Prendergast took up the study of special technical subjects. He entered the service of the Baltimore & Ohio in the mechanical department in 1893 as an apprentice, and after completing his apprenticeship he served as a machinist, and subsequently was made foreman. He was then promoted to master mechanic at Grafton, W. Va., and later was transferred in the same capacity to the Riverside shops at Baltimore, Md., becoming master mechanic at the Mt. Clare shops, Baltimore, on January 1, 1910. The following November he was made superintendent of motive power of the Baltimore & Ohio Southwestern at Cincinnati, Ohio, and in May, 1912, his authority was extended over the Cincinnati, Hamilton & Dayton. In January, 1913, he was appointed superintendent of motive power of the Baltimore & Ohio proper, with headquarters at Baltimore, Md., from which position he resigned on December 31, 1913.



A. P. Prendergast

T. W. HEINTZELMAN, superintendent of motive power of the Southern Pacific at Sacramento, Cal., has been appointed general superintendent of motive power, with headquarters at San Francisco, Cal., succeeding H. J. Small, retired.

D. J. MULLEN has been appointed assistant to the superintendent of motive power of the Cleveland, Cincinnati, Chicago & St. Louis, with headquarters at Indianapolis, Ind.

H. OSBORNE has been appointed assistant mechanical superintendent of the Canadian Pacific, with headquarters at Montreal, Que.

H. J. SMALL has retired as general superintendent of motive power and machinery of the Southern Pacific. Mr. Small has been in railway service since 1868, when he commenced as a machinist for the Chicago & North Western at Chicago. He was from 1869 to 1874 successively draftsman for the Kansas Pacific, the Northern Pacific and the Toledo, Wabash & Western. The succeeding three years he was general foreman of the International & Great Northern, and from 1877 to 1879 was master mechanic of the Galveston, Houston & Henderson. He was then for two years master mechanic of the Texas & Pacific, returning to the Northern Pacific in 1881 as assistant superintendent of machinery, where he remained until 1886. From 1887 to 1888 Mr. Small was assistant superintendent of motive power of the Philadelphia & Reading, and he then went to the Southern Pacific as superintendent of motive power and machinery. On July 1, 1902, he was made general superintendent of motive power and machinery, with headquarters at San Francisco, Cal., from which position he now retires.

F. O. WALSH has been appointed superintendent of motive power and equipment of the Georgia Railroad, with headquarters at Augusta, Ga.

W. E. WOODHOUSE, assistant superintendent of motive power of the western lines of the Canadian Pacific, has been appointed superintendent of motive power of the eastern lines, with headquarters at Montreal, Que.

T. W. YOUNGER has been appointed superintendent of motive power of the northern district of the Southern Pacific, with headquarters at Sacramento, Cal., succeeding T. W. Heintzelman, promoted.

### MASTER MECHANICS AND ROAD FOREMEN OF ENGINES

WILLIAM APTEED has been appointed road foreman of engines of the Michigan Central at Detroit, Mich., succeeding W. R. Walsh.

W. S. BUTLER, master mechanic of the Chesapeake & Ohio at Hinton, W. Va., has been appointed master mechanic of the Huntington and Big Sandy divisions, with headquarters at Huntington.

J. J. CAREY has been appointed master mechanic of the Cincinnati, Hamilton & Dayton at Ivorydale, Ohio, succeeding C. A. Gill.

D. C. CLOUGH has been appointed master mechanic of the Oregon Electric and the United Railways, with office at Portland, Ore., succeeding G. H. Hopkins, resigned.

W. H. DAVIES has been appointed road foreman of engines of the Chicago & Alton, with headquarters at Bloomington, Ill.

JOHN DICKSON has been appointed general master mechanic of the Spokane, Portland & Seattle, the Oregon Trunk, Oregon Electric and United Railways, with headquarters at Portland, Ore. Mr. Dickson began railway work as machinist apprentice with the Great Northern. He was subsequently until 1899 machinist, air brake man and draftsman, leaving that road to become instructor in the Mechanic Arts High School at St. Paul, Minn. He remained in that position for two years, returning to the Great Northern as general air brake instructor, and was successively superintendent of shops at Everett, Wash., and



master mechanic of the Dakota division. He has been with the Spokane, Portland & Seattle as master mechanic since it was first put in operation, and on February 1 was made general master mechanic, as above noted.

J. G. DOLE, whose appointment as master mechanic of the Alliance division of the Chicago, Burlington & Quincy, with headquarters at Alliance, Neb., was announced in the February issue, was born November 7, 1880, at Mohicanville, Ohio, and received a high school education. He began railway work in October, 1897, with the Chicago, Burlington & Quincy as machinist apprentice, and from 1902 to 1906 was successively machinist for the Northern Pacific and the Chicago & North Western. The following two years he was employed by the Missouri Pacific as division foreman at Coffeyville, Kan., general foreman at Osawatimie, Kan., and as division foreman at Wichita, Kan. He then returned to the Burlington in 1908 as general foreman at Denver, Colo., and later was transferred to Lincoln, Neb., in a similar capacity, holding this position until January 16, when he was promoted to division master mechanic at Alliance, Neb., as above noted.

W. J. EDDY has been appointed master mechanic of the Louisiana division of the Rock Island Lines at El Dorado, Ark., succeeding R. C. Hyde, promoted.

W. A. HALL has been appointed master mechanic of the International & Great Northern at Mart, Tex., succeeding T. H. Williams.

W. P. HOBSON, master mechanic of the Cincinnati division of the Chesapeake & Ohio, has had his jurisdiction extended over the Ashland division, with headquarters at Covington, Ky.

C. M. HUFFMAN has been appointed master mechanic of the San Pedro, Los Angeles & Salt Lake at Milford, Utah, succeeding J. M. Gailey.

R. C. HYDE has been appointed master mechanic of the Minnesota division of the Rock Island Lines at Manly, Iowa, succeeding F. W. Williams, resigned.

A. J. KLUMB has been appointed assistant master mechanic of the Chicago, Milwaukee & St. Paul at Milwaukee, Wis., succeeding C. Lundburg.

F. R. PENNYFATHER, district master mechanic of the Canadian Pacific at Cranbrook, B. C., has been appointed master mechanic of the Manitoba division, with headquarters at Winnipeg, Man.

G. W. ROBERTSON, master mechanic of the Ashland division of the Chesapeake & Ohio at Lexington, Ky., has been appointed master mechanic of the Hinton division, with headquarters at Hinton, W. Va.

A. ROESCH has been appointed master mechanic of the Colorado & Southern at Trinidad, Colo., succeeding J. M. Davis.

W. E. STOERMER has been appointed road foreman of engines of the Southern Pacific at Los Angeles, Cal., succeeding C. H. Holdredge.

F. E. WOLFE has been appointed road foreman of engines of the Pere Marquette at Grand Rapids, Mich.

#### CAR DEPARTMENT

H. H. GERBACH has been appointed car foreman of the Great Northern at Great Falls, Mont., succeeding C. J. Grant.

T. E. HESSENBRUCH has been appointed assistant general car inspector of the Philadelphia & Reading, with headquarters at Reading, Pa.

R. B. RASBRIDGE has been appointed superintendent of the car department of the Philadelphia & Reading, with headquarters at Reading, Pa.

CHARLES RAY has been appointed car foreman of the Chicago,

Milwaukee & St. Paul at Tacoma, Wash., succeeding E. S. Hartow.

W. SNELL has been appointed general foreman of the car department of the Chicago, Milwaukee & St. Paul, at Minneapolis, Minn., succeeding W. A. Parker.

R. D. WILSON has been appointed general car inspector of the Philadelphia & Reading at Reading, Pa., succeeding R. B. Rasbridge, promoted.

#### SHOP AND ENGINE HOUSE

WILLIAM BELYEA has been appointed general foreman of the Pere Marquette at Benton Harbor, Mich.

GEORGE C. BINGHAM has been appointed general foreman of the Chicago & North Western at Huron, S. D., succeeding F. W. Anderson.

R. L. BLACK has been appointed general foreman of the Norfolk & Western at Columbus, Ohio.

T. L. BROWN has been appointed general foreman of the Norfolk & Western at Kenova, W. Va.

D. W. DAY has been appointed locomotive foreman of the Grand Trunk Pacific at Jasper, B. C., succeeding F. Lozo, transferred.

R. DENNIS has been appointed general foreman of the Toledo & Ohio Central at Columbus, Ohio, succeeding G. P. Young.

B. FERRIS has been appointed acting general foreman of the Detroit, Toledo & Ironton at Delray, Mich.

P. J. FLYNN has been appointed general foreman of the Delaware, Lackawanna & Western at Syracuse, N. Y., succeeding B. F. Roosa.

F. Lozo has been appointed locomotive foreman of the Grand Trunk Pacific at McBride, B. C., succeeding A. H. Mahan, transferred.

A. H. MAHAN has been appointed locomotive foreman of the Grand Trunk Pacific at Prince George, B. C.

N. W. NORSWORTHY has been appointed general foreman of the Norfolk & Western at Crewe, Va.

GEORGE SCHIMMING has been appointed shop foreman of the Chicago & North Western at Madison, Wis., succeeding J. F. Cosgrove.

#### PURCHASING AND STOREKEEPING

SAMUEL F. CLARK has been appointed purchasing agent and general storekeeper of the Spokane, Portland & Seattle, with headquarters at Portland, Ore., succeeding J. E. Mahaney, resigned.

E. O. GRIFFIN, general storekeeper of the International & Great Northern, with office at Palestine, Tex., has been appointed also general fuel and supply agent.

H. L. RICHARDSON has resigned as fuel agent of the St. Louis, Brownsville & Mexico at Houston, Tex., and the office has been abolished.

C. T. TILLMAN, treasurer and acting purchasing agent of the South Georgia, at Quitman, Ga., has been appointed purchasing agent with office at Quitman.

#### OBITUARY

A. B. ADAMS, division master mechanic of the Gulf, Colorado & Santa Fe at Silsbee, Tex., died suddenly on February 16, aged 49 years.

NEWELL S. KIMBALL, for 30 years district master mechanic of the Chicago, Milwaukee & St. Paul at Green Bay, Wis., died in Chicago on January 31, aged 82 years.

## SUPPLY TRADE NOTES

Edward W. Hodgkins has resigned his connection with Guilford S. Wood, Chicago, to engage in business for himself.

Karl A. Heine has joined the sales department of the Chicago Car Heating Company, with office in the Grand Central Terminal building, New York City.

John L. Randolph has been appointed eastern sales manager of the Economy Devices Corporation, 30 Church street, New York. Mr. Randolph was born in Boston, Mass., August 25, 1878, attended the public schools and was graduated from the English High School of that city. His railroad career began as a machinist apprentice in the Concord, N. H., shops of the Northern Railroad now a part of the Boston & Maine. Subsequently he served this road in the capacity of machinist, gang foreman, general foreman, master mechanic, and superintendent of shops at Keene, N. H. In April, 1911, he accepted a position with the Franklin Railway Supply Company in the mechanical department and remained with that company until February 1, 1914, when he was appointed eastern sales manager of the Economy Devices Corporation, as noted above.

Earl A. Averill has resigned as managing editor of the Railway Age Gazette, Mechanical Edition, and on March 1 goes with the Standard Stoker Company, Grand Central Terminal,

New York, as engineer of operation. Mr. Averill joined the staff of the American Engineer and Railroad Journal on January 1, 1906, as an editor, and on April 1, 1910, became managing editor. He has continued in that position since the purchase of that publication by the Simmons-Boardman Publishing Company. He was born at Richland, N. Y., on August 13, 1878, and after a preparatory education in public and private schools, entered Cornell University in 1896. He was graduated in 1900 with the degree of mechanical engineer,

having specialized during his senior year in railway mechanical engineering. He began his practical railroad work in the summer of 1899 in the shops of the Philadelphia & Reading, Reading, Pa., and, on graduation, went with the Chicago, Burlington & Quincy, at West Burlington, Ia., reporting to J. F. Deems, who was then master mechanic at that point. After four years'

service with the Burlington, most of which was spent in the shop, roundhouse and on the road, Mr. Averill joined the staff of the Railway and Engineering Review of Chicago, where he remained for over two years. He left that publication to come to New York with the American Engineer and Railroad Journal. With the Standard Stoker Company he will have charge of the installing and preliminary operation of the stokers as well as all tests, records of service, etc.

W. F. Bauer has resigned from the United States Light & Heating Company, to become assistant manager of the railway department of the Edison Storage Battery Company, Orange, N. J.

A. C. Adams has resigned his position of superintendent of motive power of the Spokane, Portland & Seattle to become the Pacific coast general agent of the General Brake Shoe & Supply Company, Chicago, and will have headquarters at 907-908 Wilcox building, Portland, Ore.

The Chicago Car Heating Company has recently opened a branch office and factory at 61 Dalhousie street, Montreal, Canada. A. D. Bruce, former purchasing agent of the company at Chicago, is in charge. Mr. Bruce is a native of Guelph, Ont., but has been connected with the Chicago Car Heating Company in Chicago for the past five years.

Bertram Smith has been appointed assistant manager of the Edison Storage Battery Supply Company, San Francisco, which handles the Edison battery on the Pacific coast. Mr. Smith started in the storage battery business in 1899 with the National Battery Company, Buffalo, N. Y. He was secretary and treasurer of that company for three years, but since its absorption by the United States Light & Heating Company, he has been manager of the latter company's battery department.

Charles Henry Schlacks, whose election to the presidency of the Hale and Kilburn Company, Philadelphia, Pa., was announced in the February issue, was born in Chicago on November 12, 1865. He entered railway service when he was but fourteen as an office boy on the Illinois Central. He then became a machinist's apprentice, and was consecutively to 1891 mechanical draftsman, chief clerk to the superintendent of machinery and chief clerk to the general superintendent. In November, 1891, he was appointed assistant to the general manager of the Denver & Rio Grande. On November 1, 1894, he became assistant general manager of that road and retained that position until July 1, 1900, when he was appointed also general manager of the Colorado Midland. On June 1, 1904, he became a vice-president of the Denver & Rio Grande. On November 5, 1909, he also became the first vice-president of the new Western Pacific, the western extension of the Denver & Rio Grande, removing his headquarters to San Francisco, Cal., and was an important factor in the work of getting that road in complete and efficient working order. He was thus for a time the first vice-president of the Western Pacific, vice-president of the Denver & Rio Grande, the Colorado Midland, the Rio Grande Southern and the Utah Fuel Company, and president of the Globe Express Company.



J. L. Randolph



E. A. Averill



C. H. Schlacks



## CATALOGS

**HYDRAULIC PRESSES.**—Heating, chilling and die presses are fully illustrated and described in a 56 page catalog issued by the Watson-Stillman Company, 50 Church street, New York. This is catalog No. 89.

**MECHANICAL RUBBER GOODS.**—Valve discs, sheet packing, pump valves, gaskets and other similar mechanical rubber parts are illustrated and described in a small catalog issued by Jenkins Bros., 80 White street, New York.

**BRAKE SHOES.**—The Pittsburgh brake shoe has a steel shell filled with composition and gives a very high friction with a long wear. It is illustrated and described in a leaflet being issued by the Pittsburgh Brake Shoe Company, Farmers' Bank building, Pittsburgh, Pa.

**HAND-TRAVELING CRANES.**—The Brown Hoisting Machinery Company, Cleveland, Ohio, is issuing a leaflet descriptive of the Brownhoist single I-beam, hand-traveling crane which is built for easy operation and long life. The illustrations show a number of the more interesting details.

**LOCOMOTIVE CRANES.**—A 55 page book from the Industrial Works, Bay City, Mich., illustrates and describes locomotive cranes for construction, industrial and railroad purposes. This is known as book No. 108 and is a most attractive publication typographically. Some of the illustrations are given in color and all are most interesting. It shows locomotive cranes working under a variety of conditions and illustrates many special designs. Wrecking cranes are given a section of the book.

**DRILLS, REAMERS, ETC.**—Catalog No. 15 of the Rich Tool Company, Railway Exchange, Chicago, illustrates and clearly describes a complete line of high speed twist drills, reamers, track bits, flat drills, bonding drills, drill chucks, reamer chucks and rivet sets manufactured by this company. Tables of sizes and prices accompany each style illustrated.

**CHAIN DRIVE.**—A leaflet from the Morse Chain Company, Ithaca, N. Y., gives short descriptions of typical Morse silent chain drives, showing their durability and efficiency for long periods of time. Many of these applications are to motor driven machine tools. A table is inserted showing a list of the installations of thirty-one original chain drives in the shops of the Pittsburgh & Lake Erie at McKees Rocks. This table shows the present condition of drives that have been in regular service from five to ten years each.

**BULLSEYE LOCOMOTIVE LUBRICATORS.**—An attractive 56 page catalog No. 36L has been issued by the Detroit Lubricator Company, Detroit, Mich. It fully describes the principle of the hydrostatic lubricator and the features of design of the modern types of bullseye lubricator. The latest developments in this line are illustrated in a complete manner and instructions for operating, cleaning and adjusting are included. The Detroit transfer filler which will allow the lubricator to be refilled at any time while in service, is also discussed at some length. Accessories in connection with the lubrication of locomotives are shown.

**LOCOMOTIVE RATIOS.**—Bulletin No. 1,017 from the American Locomotive Company, 30 Church street, New York, is devoted to a discussion of locomotive ratios by F. J. Cole, chief consulting engineer. Included in the discussion are a number of very valuable tables of reference giving cylinder horse power of saturated and superheated steam locomotives for various pressures and diameters of cylinders; evaporation from tubes and flues in pounds of steam per hour per square foot for different diameters and lengths; heating surface of tubes for different diameters and lengths and the ratios of the outside heating surface to the diameter and spacing of tubes. The discussion of the

various ratios is largely confined to features of the boiler and present a number of new proportions which have been thoroughly tried out in practice and are known to be correct.

**ELECTRIC STEEL CASTINGS.**—The process of making electric steel consists of melting down a charge directly in an electric furnace or in transferring molten steel from the open hearth or Bessemer convertor to an electric furnace and there maintaining the charge in a molten state under complete chemical control in a neutral atmosphere, until it is refined and purified. It is claimed that this method will allow a production of steel which possesses certain characteristics and advantages to a degree not found in ordinary processes. This material gives castings which have the highest degree of uniformity combined with great toughness, strength and flexibility. Illustrations of the furnaces used and discussion of the product, including the results of a number of tests are given in a catalog which is being issued by the National Malleable Castings Company, Sharon, Pa.

**DUMP CARS.**—Extension side dump cars of from 12 cu. yd. to 20 cu. yd. capacity are the subject of a catalog being issued by the Clark Car Company, Pittsburgh, Pa. In this type of car a new feature is presented which consists of having the side of the box turned downward as the box is inclined which makes an extension or shelf that protects the truck and track from back filling and leaves a clear space above to discharge the load. It is claimed that this arrangement improves the construction of the car by permitting the sides to be hinged to the body throughout their length, and by having side operating cross frames at intermediate positions as well as at the ends of the car. These cars are made with air or hand operating mechanism or the two can be combined. The catalog shows a number of illustrations and contains a very complete description of all the features of construction.

**HEATING AND VENTILATION.**—It was over 25 years ago that the first edition of the book known as "Heating and Ventilation," was published by the B. F. Sturtevant Company, Hyde Park, Boston, Mass. Since that time frequent new editions have been brought out, keeping pace with the increased knowledge of the subject and the improvement in the apparatus, but until the present edition, no decided change was made in the form of book. Recently, however, the advancement in this line has been so rapid that it has made it necessary to revise the book completely. In doing this an endeavor has been made to make it more generally useful as a book of reference which will be equally valuable to the engineer and to the layman. The arrangement has therefore been changed and the index has been made more thorough. It is in two parts. The text matter makes up part one and is divided in ten chapters which are further divided in sections, all numbered and provided with titles to aid the reader in finding the information he desires. The second part is a collection of tables for the use of the student and engineer covering the subject of heating and ventilation in general and of the Sturtevant apparatus in particular. The ten chapters in the first part are on different subjects as follows: Chapter 1 considers air, its composition, properties and principal characteristics. Chapter 2 deals with the subject of ventilation; chapter 3 with heat; chapter 4, the Sturtevant system of combining heating and ventilation, and chapter 5 a general study of the apparatus used in heating and ventilating installations. Chapter 6 gives assistance on the considerations of problems involved in calculating heating and ventilating systems. Chapter 7 is devoted to the testing of the system. Chapter 8 is a consideration of the individual problems involved in the ventilation and heating of distinctive types of buildings and chapter 9 is a description of typical installations and apparatus. Chapter 10 briefly describes Sturtevant apparatus. The tables are very complete and cover practically all the information that is necessary for a detailed and extensive investigation of this subject.

# Railway Age Gazette

MECHANICAL EDITION

## INCLUDING THE AMERICAN ENGINEER

PUBLISHED ON THE FIRST THURSDAY OF EVERY MONTH BY THE  
SIMMONS-BOARDMAN PUBLISHING COMPANY,  
WOOLWORTH BUILDING, NEW YORK, N. Y.

CHICAGO: Transportation Bldg. CLEVELAND: Citizen's Bldg.  
LONDON: Queen Anne's Chambers, Westminster.

EDWARD A. SIMMONS, *President* L. B. SHERMAN, *Vice-President*  
HENRY LEE, *Secretary*  
The address of the company is the address of the officers.

ROY V. WRIGHT, *Editor*  
R. E. THAYER, *Associate Editor* A. C. LOUDON, *Associate Editor*  
GEORGE L. FOWLER, *Associate Editor*

Subscriptions, including the eight daily editions of the *Railway Age Gazette* published in June in connection with the annual conventions of the Master Car Builders' and American Railway Master Mechanics' Associations, payable in advance and postage free:

United States, Canada and Mexico.....	\$2.00 a year
Foreign Countries (excepting daily editions)....	3.00 a year
Single Copy .....	20 cents

Entered at the Post Office at New York, N. Y., as mail matter of the second class.

WE GUARANTEE, that of this issue 4,250 copies were printed; that of those 4,250 copies, 3,665 were mailed to regular paid subscribers and 150 were provided for counter and news companies' sales; that the total copies printed this year to date were 17,300—an average of 4,325 copies a month.

Statement of the ownership, management, etc., of the *Railway Age Gazette*, *Mechanical Edition*, published monthly at New York, N. Y.:

Editor, ROY V. WRIGHT, New York, N. Y.  
Publisher, SIMMONS-BOARDMAN PUBLISHING CO., New York, N. Y.

**STOCKHOLDERS:**

EDWARD A. SIMMONS, New York.	ROY V. WRIGHT, New York.
LUCIUS B. SHERMAN, Chicago, Ill.	ELMER T. HOWSON, Chicago, Ill.
HENRY LEE, New York.	A. C. BOARDMAN, Riverdale, N. Y.
I. B. RINES, New York.	F. BOARDMAN, Riverdale, N. Y.
SAMUEL O. DUNN, Chicago, Ill.	B. BOARDMAN, New York.
	RAY MORRIS, New York.

**BONDHOLDERS:**

S. W. DUNNING, New York.	CHARLES M. PRATT, New York.
ESTATE OF WM. H. BOARDMAN, N. Y.	C. C. NEWCOMB, Brooklyn, N. Y.
W. H. SHUEY, Chicago, Ill.	M. D. HORTON, Brooklyn, N. Y.

SIMMONS-BOARDMAN PUBLISHING COMPANY,  
By E. A. SIMMONS, President.

Sworn to and subscribed before Harry E. French, Notary Public for Kings County, N. Y. (No. 12), whose certificate is filed with the County Clerk of New York (No. 8), and whose commission expires March 30, 1914, on March 16, 1914.

VOLUME 88 APRIL, 1914 NUMBER 4

### CONTENTS

**EDITORIALS:**

Schedules for Locomotive Repairs.....	165
Economizing in Cab Curtains.....	165
Railway Accidents.....	166
Excessive Weight in Rolling Stock.....	166
The Draft Gear Competition.....	166
New Books.....	167

**COMMUNICATIONS:**

The College Man and the Railroads.....	168
--	-----

**GENERAL:**

Interesting Mikado Type Locomotive.....	169
Career of George Westinghouse.....	173
Compound Locomotives.....	175
Service of Vanadium Steel Tires.....	175
Tabular Comparisons of Recent Locomotives.....	176
Watering the Rails to Prevent Slipping.....	178

**CAR DEPARTMENT:**

Freight Car Repairs.....	179
The Clasp Brake.....	180
Northern Pacific Stock Car.....	181
Heater Cars.....	184
Car Lighting.....	184
New Haven Steel Coach.....	185
Brake Efficiency Tests on Steel and Iron Wheels.....	187
Cast Iron Car Wheel Design.....	189
Steel Ends for Box Cars.....	190

**SHOP PRACTICE:**

Locomotive Mileage and Repair Records on the Canadian Pacific.....	191
Firebox Riveting.....	191
Inspection and Work Schedules.....	193
A Cheap Method of Making Brake Shoe Keys.....	197
Efficiency.....	197

SHOP PRACTICE—Continued:

Locomotive and Car Repair Notes.....	198
Chuck for Turning Eccentrics.....	199
Adjustable Platform for Car Shops.....	200
Some Modern Methods of Welding.....	200
Grinding Wheels and Their Use.....	201
Feed Valve Test Rack.....	202

**NEW DEVICES:**

Bridgeford Gap Axle Lathe.....	203
Derihon Portable Hardness Testing Machine.....	204
Improved Hanna Locomotive Stoker.....	206
Lennox Serpentine Shear.....	207
Mud Ring and Tube Sheet Drill.....	208
Cross Compound Air Compressor for the Lackawanna.....	208
Variable Speed and Reversing Attachment.....	209
Cincinnati Cylinder Planer.....	210
Boring and Turning Mill.....	210
Standard 48 in. Planer.....	211
Hydraulic Shaft Straightener.....	211
Fire Extinguisher.....	212

**NEWS DEPARTMENT:**

News.....	213
Meetings and Conventions.....	214
Personals.....	215
Supply Trade Notes.....	217
Catalogs.....	219

**Schedules for Locomotive Repairs**

The advantages to be obtained through the use of a system of schedules in making repairs to locomotives need no enlarging upon. Locomotive repairs are, however, of a nature that makes the preparation of such a schedule difficult. Flexibility is required to a considerable extent; but there is no obstacle that is insurmountable, and considerable success has attended the gradual development of the system in use at the Angus shops of the Canadian Pacific, which is described elsewhere in this issue. This system has been worked out in conjunction with that of inspection, and the organization adopted is such that the two systems are largely interwoven. A point in connection with the inspection work that is worthy of emphasis is the preliminary inspection of the locomotives immediately after their arrival. Anyone familiar with the length of time engines frequently stand obstructing the erecting floor in some shops, while awaiting the arrival of a casting or other part that has not been found to be missing or broken until the engine is in the shop and stripping has commenced, will quickly see the advantage of this practice. If a schedule system is laid out on a firm basis it will naturally broaden and develop as it continues in use, and it is not difficult to foresee the possibility of the close determination, on the day the engine is taken in the shop, of what the cost of making the necessary repairs will be. The advantage of this knowledge to the shop superintendent in laying out his work to suit his appropriation, can readily be seen.

**Economizing in Cab Curtains**

About this time of year side and back curtains and their rods are removed from locomotives. Quite likely they are thrown in an out of the way corner of the engine house and left there; some of them will become damp and the canvas will rot, or if any of the engine house men need a piece of canvas for any purpose during the summer the curtains will form the supply. When the weather again becomes so cold that enginemens refuse to go out without side and back curtains, the remains will be resurrected and a general survey made. By means of considerable patching, enough curtains for half the engines at the terminal may be found; the other half remain curtainless until a new supply of canvas can be ordered and new curtains made up. Beside the resultant discomfort to enginemens and trouble for the engine house foreman, this practice is expensive to the railway company. It constitutes one of the small leaks that can very easily be stopped. It is a simple matter to look over a set of curtains when they are removed in the spring and decide whether or not they need repairing. If they are in good condition they can be locked up in a suitable place under the charge of the storeman, after being tagged with the class (and, if thought necessary, the number) of the locomotives for which they are suitable. Curtains that need repairing are then tagged in the same way and sent to the



general shops, where they are overhauled. The superintendent of motive power is furnished with a list, showing the curtains on hand in good condition and those sent in for repairs. The general shops, when the repairs are completed, send in a similar list showing the good curtains on hand. When cold weather returns the head of the motive power department then knows, regardless of how much the power may have been shifted during the summer months, just where each set of curtains is, and he can order them applied or shipped elsewhere for application so that each locomotive will be provided with them when they become necessary.

#### Railway Accidents

A study of Accident Bulletin No. 48 recently issued by the Interstate Commerce Commission for the year ending June 30, 1913, discloses the fact that much needs to be done by everybody connected with railroads to reduce the number of accidents. This does not mean, however, that railroad-ing is any more hazardous than a good many other industrial operations. For instance, the United States Bureau of Mines recently issued statistics showing that the mortality rate in the coal mines during the year ending June 30, 1913, was 3.82 for every 1,000 men employed, while the rate for the railways is only 2.2 for every 1,000 employees. Automobile fatalities have also grown with alarming rapidity with the increasing use of these vehicles, and in New York state alone in one year more people were killed by automobiles than were passengers by all the railroads in the United States.

A fair comparison of the accidents on railways with other industries and means of transportation will not show that railroad operation is any more hazardous. But, of course, it is the desire of everyone to prevent, so far as possible, injury and death to others, and there is an opportunity of decreasing the number of accidents on railways. The accident bulletin above referred to shows that out of 171,417 railway employees injured 54,554 were injured in and around shops. This is the largest item mentioned in the table of casualties, and is about 32 per cent of the total number. It is expected, however, that this number will be greatly reduced as time goes on, when the "safety first" movement is adopted by all the roads and becomes more carefully organized.

Another item which it behooves the mechanical department of the railways to watch closely, is the derailments caused by defects in equipment. While only 1,245, or 19 per cent of the total number of people injured in derailments, were injured on account of defective equipment, the loss in money far exceeded that of any other cause mentioned under derailments, it being \$3,421,037, or about 41½ per cent of the total amount. The defective equipment is classified under wheel failures, truck failures, brake equipment failures, axle failures and draft gear failures. The most disastrous of these were the wheel failures, which caused 28 per cent of the total number of accidents from this cause, and cost the roads \$1,163,129, or 34 per cent of the cost of derailments due to defective equipment. From an analysis of the causes of these derailments it would seem that they could have been prevented by more careful inspection.

#### Excessive Weight in Rolling Stock

Attention has been drawn, on a number of occasions in these columns, to the futility and false economy of selecting a design for a freight car on the basis of first cost alone. All railway expenditures, particularly under present day conditions, must of necessity be kept as low as is consistently possible, but the practice is not consistent, of buying cheap cars and later paying heavy maintenance charges on them while they stand out of service on repair tracks. There is, however, another important consideration which must not be lost sight of in the efforts to design a car that will be strong enough to withstand the usage of modern operating conditions. This is the question of excessive weight, and is one that has been re-

peatedly referred to by H. H. Vaughan, assistant to the vice-president of the Canadian Pacific.

It may quite pertinently be asked, in this connection, if it is not cheaper to occasionally have a car broken up because of insufficient strength than to pay out money in operating costs for hauling the excessive dead weight contained in some of the cars of recent design. It is a comparatively easy matter to design a car that will withstand the heaviest service required by present day conditions, provided the weight is not a factor; the problem is to produce a car of reasonable strength that will spend a minimum of time on repair tracks while accumulating the least possible amount of claims for damaged and missing freight, and at the same time be of a weight that will assist to the greatest degree in keeping down the cost of train operation. No car can be built that will run indefinitely without repairs. It has never been seriously contended that cars should be designed with a view to eliminating the necessity for repair tracks; but there should be a mean somewhere between the car that is cheap in first cost with resultant high maintenance charges and damage claims, and the car that, while standing up under the most severe service, is excessively heavy. Mechanical department men are too prone to look only at their own side of this question. It is very easy to become absorbed in the reduction of department expenses and overlook an increase in the cost of moving the company's business; and it requires no expert calculations to show the amount to which a few thousand pounds extra dead weight per car may swell the total of non-revenue ton miles.

It cannot be said that the matter of excessive weight has been or is being entirely neglected by car designers, but it does seem as if it had been accepted by many as a direct product of modern conditions, and therefore a necessary evil. This applies to passenger equipment as well as to freight. The careful consideration necessary in deciding on the design of steel passenger train cars was brought out clearly in the following statement contained in a paper read before the New England Railroad Club on February 10, by F. M. Brinkerhoff:

"Assuming that the cost of power for hauling one pound of car weight per year averages one cent, and, in rapid transit service this cost is usually safely assumed as five cents, it is obvious that, before a railroad company adopts a method of steel passenger train car design, time will be well spent for an investigation of the most searching and conscientious character into the various methods of constructing steel passenger train cars in order to secure for service a car of minimum weight, though still possessing suitable strength and all other necessary characteristics."

Until recently, American locomotive designers gave too little consideration to the question of dead weight. The increasing sizes of locomotives have at last forced them to the employment of refinements to keep weights within reasonable limits. Conditions indicate the necessity of following similar lines in car designing.

#### The Draft Gear Competition

The manufacturer of a car roof complained bitterly that his roof was not given a fair show on a large order because the cars were not equipped with an adequate draft gear which would absorb the shocks and act as a protection to the rest of the car. The general manager of a railroad says that the damage to lading in the freight cars would be very considerably reduced by the application of better draft gears to the freight cars. A superintendent of motive power claims that the maintenance of his freight cars is much higher than it should be and that the application of higher capacity draft gears would reduce this cost to a more reasonable figure; the added cost of the higher grade gears would be much more than offset by the savings which would result. A master car builder is authority for the statement that an overcrowded and congested repair point would be relieved, and in fact would be

much larger than necessary if it were not for the damage which is caused by the use of low capacity draft gears on freight cars. In each case a request for exact figures as to the loss caused by the inferior gear or the saving which might be made by the application of a higher grade gear was met with the reply that it was impossible to present exact figures, but that experience would demonstrate the truth of the statements. While this may be true, the executive who is responsible for the heavy expenditures which would be involved cannot be too severely criticised if he insists that he must have more exact data on which to base his course of action.

One might naturally expect that an answer to his demand for such information would be found in the proceedings of the Master Car Builders' Association, which has done such effective work in standardizing and improving conditions pertaining to rolling stock. Unfortunately this is not the case. While it is true that very extensive tests of the various types of draft gears have been made by this association, they were carried out under conditions which are not at all comparable to those met with in service. In a report of the coupler and draft gear committee in 1909, under the head of Friction Draft Gear, we find this statement: "In order to procure definite information on the performance of existing gears, as well as information from which to base future designs, it is believed that the following policy should be followed: First, the carrying out of a comprehensive series of service tests with accurate recording devices; and, second, the design of a laboratory testing arrangement which will subject the gears to approximately the same pressures and shocks as received in service. With the above in view, a study of previous tests has been made, but although data of exceeding interest have been placed at the disposal of your committee, by both railroad companies and manufacturing concerns, there is really little definite knowledge available. . . . As mentioned in the report of last year, the good friction gears are undoubtedly an improvement in protecting equipment from constant severe shocks due to their greater capacity and to their ability to absorb the force of the blows instead of returning it to the cars in the form of recoil as is done by the spring gear."

The report of the same committee at the 1910 convention of the Master Car Builders' Association suggested that after careful consideration it was decided that it would not be feasible to study the performance of draft gears by means of a series of road tests with accurate recording apparatus, but that the use of a laboratory testing apparatus which would approximate service conditions would give satisfactory results. The design of a pendulum testing machine was presented which it was believed would fulfill these conditions, and the committee closed its report on the friction draft gear with this statement: "Your committee regrets that it has been unable to perfect the machine in time to have had a series of tests made during the past year, but it expects to have the machine set up and make a series of tests of all kinds of friction draft gears now on the market, submitting a complete report at the convention of the year 1911 on the efficiency of friction draft gears." For some reason or other the subject was dropped by the coupler and draft gear committee and no mention of it occurs in any of the three succeeding years, 1911, 1912 and 1913. This was undoubtedly because the committee has had to give a very great amount of time and investigation during the past few years to the development of a standard coupler.

As stated in the editorial on this subject which appeared in our March issue, the real basis upon which to judge the merits of the different draft gears must be on their service performance. Thus far only one railroad officer, J. C. Fritts, master car builder of the Delaware, Lackawanna & Western, has published any accurate data as to service results of different types of gear. This was presented at the September meeting of the Central Railway Club, and has been commented on at various times in these columns. Undoubtedly there are other railway

officers who have made similar investigations or who have in their possession reliable data on the draft gear subject which will be of much value to the railroads generally. With this in mind we propose to offer a prize of \$100, as announced in our March issue, for the best article received in this office on or before May 15, 1914, on the draft gear problem. The manner in which the subject may be approached by those who wish to contribute will, of course, depend entirely upon their experience and observation; but the judges will base their decision on the facts and evidence which are presented to show what types of draft gear are giving the best results. Such articles as are suitable for publication but which are not awarded the prize will be paid for at our regular space rates.

## NEW BOOKS

*Electric Car Maintenance.* By Walter Jackson, associate editor, Electric Railway Journal. 270 pages. 6 in. by 9 in. Illustrated. Bound in cloth. Published by the McGraw-Hill Book Company, Inc., 239 West 39th street, New York. Price \$3.

The contents of this book have been selected from the columns of the Electric Railway Journal, except that some braking and wiring diagrams were added in order to secure a more extensive series of shop instruction prints. The work places in a convenient form a great deal of useful data which hitherto had been lost to most shop men within a few months after the original publication in periodical form. As a rule the methods described are such as require no costly apparatus and of a kind that can be applied to a great many situations. Among the subjects considered are mechanical appliances for train operation, the non-electrical parts of the car body, brake equipment, trucks, wheels and axles, car washing and painting, sanders and sanding devices, lubrication, bearing practice, current collecting devices, motors and gearings, control, circuit-breakers, controllers and resistances, heaters, lighting, signs and signals. The book is well printed and completely illustrated.

*Work, Wages and Profit.* By H. L. Gantt. Second edition, revised and enlarged. Bound in cloth. 5 in. by 7½ in. 292 pages. Illustrated. Published by the Engineering Magazine Company, 140 Nassau street, New York. Price \$2.

There has probably been no book published that gives as clear an illustration of the advantages that result in certain instances from the application of the principles of scientific management, as Mr. Gantt's work entitled *Work, Wages and Profit*, which was first published in 1910. The explanation of the principles used in his work is so simple and clear, and the methods employed are so sensible that the book is probably the most impressive of the large number that have been published on this general subject. There are few, if any, who have had a wider experience with the practical benefits of real scientific management than has Mr. Gantt, and none who have handled more interesting problems and obtained more surprising results. In the second edition the book has been enlarged from nine chapters to twelve, the number of colored charts has been increased from six to twelve, and many additional instances of the results of scientific management are recited. Furthermore, the book gives a summation of the argument in the form of a comprehensive and entire outline of a plan of scientific management based on the policies and methods defined by Mr. Gantt.

*Application of Power to Road Transport.* By H. E. Wimperis, M.A., M.I.E.E. 125 pages. 4¾ in. by 7¼ in. Illustrated. Bound in cloth. Published by D. Van Nostrand Company, 25 Park Place, New York. Price \$1.50.

This book is based on a series of six lectures delivered at the Finsbury Technical College. Little has hitherto been written on this subject, and there is a paucity of published experimental data to serve as a substantial basis for design. The writer has endeavored to formulate a working theory based upon such tests



as he found available or was able to make independently with the accelerometer. The book begins with a general survey of the subject and deals with the use of steam power, internal combustion engines and electricity. The resistance to motion in relation to load, speed, wheel diameter and nature of tires is considered as well as the amount of power necessary. A chapter is devoted to the measurement of power, speed and resistance, and the use of the accelerometer and loss of power in engine friction and in transmission gears. Considerable space is devoted to the general type of steam and internal combustion engines and the vehicles on which they are used. The same chapter considers the horsepower necessary per ton and the use of gearing. An ideal curve of tractive effort is given. The fourth chapter deals with the relationship of engine dimensions and gear ratios to the work to be done and takes up the design of vehicles propelled by internal combustion engines and steam engines. Braking is also considered in this chapter. There are three appendices dealing with the energy stored in a moving vehicle, brake horse power tests made by the Royal Automobile Club and a road test report form.

*Locomotive Ratios.* By F. J. Cole. Published by the American Locomotive Company, New York, and known as its Bulletin 1017.

The ratios used for proportioning the vital parts of locomotives in the past followed precedent and had very little practical basis, or they were largely a matter of individual preference based on the experience gained from older designs. The heating surface of firebox and tubes and the grate area were usually proportioned in terms of the cylinder volume, the ratio used depending on the nature of the service in which the locomotive was to be engaged, as well as upon the type of the locomotive. In view of the many radical changes in locomotive practice which have occurred during the past few years, it is very evident that the old empirical rules are no longer adequate. The large increase in the size of locomotives, with their correspondingly larger capacity, the development of the Mikado and Mallet types requiring very large tractive effort at comparatively slow speeds, and of the Pacific and Mountain types requiring high sustained tractive effort at high speeds, together with increased boiler pressures, increased tube lengths, larger fireboxes and the very general use of highly superheated steam, make the older locomotive ratios almost useless even for roughly approximating correct locomotive proportions. The new ratios which the American Locomotive Company presents, are based entirely upon practical considerations and the results of exhaustive tests. They have the advantage of being independent of the type, size and class of service to be performed, because they are based upon cylinder and boiler horsepower, together with proper evaporating values for firebox, tubes, flues, arch tubes and combustion chamber heating surfaces.

The bulletin gives tables of data as follows: Cylinder horsepower of saturated and superheated steam locomotives for various pressures and cylinder diameters; evaporation from tubes and flues in pounds of steam per hour per square foot for different diameters, lengths and spacing; ratio of outside heating surface to diameter and spacing of tubes; height of crown, steam space and distance from crown to roof; and location of gage cocks. In the recapitulation a concrete example is given showing exactly how the data is applied to obtain the correct proportions for a locomotive of a stated type, having weight on drivers, boiler pressure, diameter of drivers and stroke of piston given. The value of the ratios set forth in this bulletin is amply certified to by Mr. Cole's statement concluding his discussion: "The method of proportioning described has been used by the American Locomotive Company for the past three years in all their locomotive designing. Numerous road tests, and records of engines in service have been investigated and carefully checked with the ratios. These three years of service have so thoroughly proven the consistency of the method that it has been adopted as the company's standard."

## COMMUNICATIONS

### THE COLLEGE MAN AND THE RAILROADS

AMES, Iowa, March 21, 1914.

TO THE EDITOR:

I served three years' special apprenticeship on one of the western roads, had a few months' experience as foreman of a round-house, and have since been engaged in teaching, and I feel that I understand some of the conditions that the apprentice has to meet. The secret of a college man's making a success of a railway apprentice course is not materially different from making a success in any other line of work; he must be willing to do what he is told and go into the work with the spirit that looks to ultimate success.

In a special course as outlined by many of the roads there is little time for the apprentice to become very proficient in that particular line, and it naturally can be said that few earn the wages they receive; but it is my opinion that if the special apprentice shows the right aptitude for the work he will earn his wages.

A great many railway officers condemn the college man because of a few special apprentices they have known who were failures. They overlook the fact that many have proven themselves able and efficient men. It has been my observation that the attitude of some special apprentices toward the work is in a large measure the fault of the foremen under whom they are working. These foremen do not hold the men to their work as strictly as they do the regular mechanics under their charge and allow them a freedom that has a disorganizing effect as well as a tendency toward making an inefficient workman. This I know to be specially true in certain instances where the apprentice was the relative of an officer. The apprentice should be held as responsible for the quantity of his work as any other employee and should be made to understand this at the beginning of his apprentice course. When it is evident in the minds of the officers who have the apprentice directly in charge, that he is not fitted for such work and his continuing in it is useless so far as the possibility of advancement is concerned, they should so advise him.

A communication in a recent issue of this paper on this subject stated that college authorities should not permit men who are naturally unsuited for mechanical engineering work to continue in this course. This is all very well provided the college professor knows when a student is unfitted for such work. It is more difficult for the teacher to find out whether a student has natural ability as a mechanical engineer when he comes in contact with him, say one day each week, and that after he has already spent two years of his college course in the preparatory or foundation work of the course, than it is for the foreman who oversees his work day after day for several months.

The best field for advancement for a special apprentice is in starting in as a sub-foreman and getting in line for advancement to the more important positions. It is evident, however, to any close observer that good foremen are not such a common commodity that they can be picked up anywhere. A good foreman is rare, and it is natural to suppose that only a few of the college men who take up railroad work will prove competent as foremen; but this does not prove that the others have no special ability. It remains for the railroads to find places where these men can be used for efficient service.

R. A. NORMAN,  
Associate Professor of Mechanical Engineering, Iowa State College.

A PANAMA CANAL EVERY YEAR.—Excavations equal to the entire amount necessary to build the Panama Canal have been made in the anthracite coal fields of Pennsylvania every year since the Panama Canal was begun. The average number of net tons of coal produced from the anthracite mines during the years 1904 to 1913 inclusive was approximately 81,000,000.

# INTERESTING MIKADO TYPE LOCOMOTIVE

Standard on the Canadian Pacific; Fitted With a Vestibule Cab; New Design of Engine Truck

BY W. H. WINTERROWD

Mechanical Engineer, Canadian Pacific Railway, Montreal, Que.

There were built during the year 1913 for the Canadian Pacific by the Montreal Locomotive Works, 75 Mikado type locomotives with a tractive effort of 42,000 lb. With but few modifications, these engines were duplicates of 20 locomotives designed and built at the Angus shops of the Canadian Pacific during 1912.

These locomotives have  $23\frac{1}{2}$  in. by 32 in. cylinders, 63 in. diameter drivers, 180 lb. steam pressure, a total heating surface of 4,738 sq. ft,\* and weigh 258,000 lb. in working order, with a weight of 198,000 lb. on the drivers.

On account of the necessity of keeping within permissible wheel load limits, an endeavor has been made to develop maximum power with minimum weight. In this connection it is of interest to note that with the weight of engine mentioned, a very large heating surface has been obtained.

With the exception that the boiler has been lengthened, and a trailer truck added, these locomotives are nearly identical with the Consolidation engines, previously the prevailing type of heavy freight power on this road. The practical value of such

The trains that these engines are hauling consist of ten and twelve cars, half of which are sleeping cars. Before the advent of the Mikado, these trains were drawn by the standard Pacific type locomotives, and to make the scheduled running time under adverse conditions, it was frequently necessary to resort to double heading. The Mikados have obviated the necessity for two engines, and under the most extreme climatic conditions are doing excellent work.

These engines embody a number of interesting features, chief of which is the engine truck. Instead of using the truck commonly known as the swing link type, a design has been used which carries the weight transmitted to it on a pair of double face centering wedges. On account of the use of these wedges the trucks are commonly called wedge trucks.

With this arrangement there is no truck center pin. The front end of the main equalizer rests on the top of a casting called the upper wedge tie, or bolster. This casting is guided in its vertical movement by the front foot plate into which it extends. To this upper wedge tie a pair of double faced wedges is bolted,

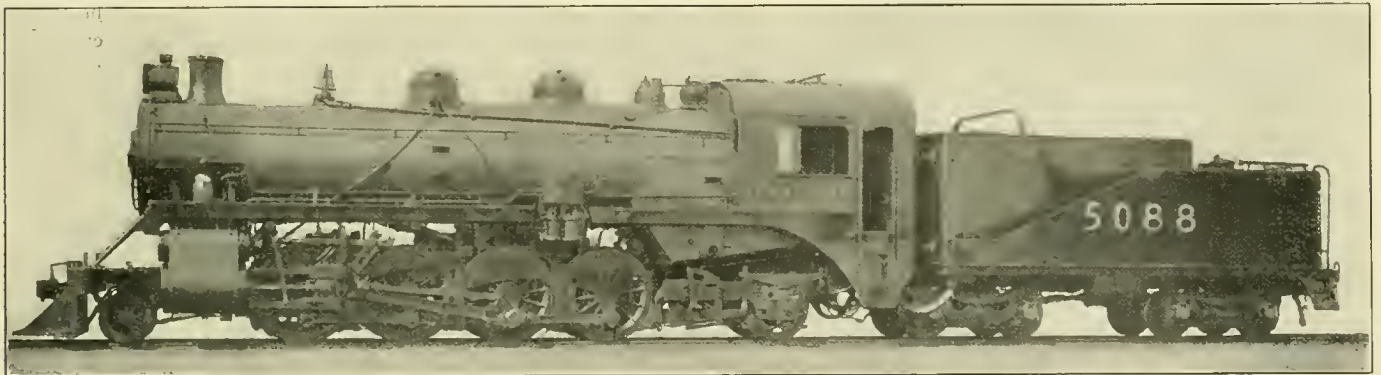

Canadian Pacific Mikado Type Locomotive

design and its beneficial effect on maintenance and repair costs is too evident to require discussion.

Although the Mikado boiler has flues 5 ft.  $2\frac{7}{8}$  in. longer and a slightly deeper throat sheet than the boiler of the Consolidation, it is a matter of interest that it is much the better steamer of the two.

It is an established fact that the Mikado type of locomotive is admirably adapted to haul slow heavy freight trains one day, and fast freight trains the next. The Canadian Pacific has gone a step farther and introduced this type of locomotive in passenger train service. The majority of the Canadian Pacific Mikados are in freight service, but a number of them have been assigned to regular passenger duty on the main line between Sherbrooke and Megantic, Que., on the Eastern division.

Between the two points mentioned the line varies 1,220 ft. in elevation within a distance of  $68\frac{1}{2}$  miles. From the accompanying profile it may be noted that within this distance the maximum gradient is 1.72 per cent, and the maximum track curvature is 6 deg. 7 min.

The scheduled time from Sherbrooke to Megantic is 2 hours 30 minutes. Deducting from this the time for four regular and two flag stops, the actual running time over the division averages 2 hours 15 minutes. This means an average speed of approximately 30 miles per hour.

\*Equivalent heating surface.

which in turn rest on a similar bottom pair bolted to the truck frame casting. The wedges themselves are so designed that, regardless of the movement of the truck, a set of faces on each pair of top and bottom wedges is always in contact.

The truck frame is a single steel casting. To this frame the pedestals and radius bars are bolted. It carries the bottom wedges, with their centers 18 in. apart. These wedges are each placed between shoulders  $\frac{1}{4}$  in. high, and in addition are held in place by four bolts of one inch diameter with countersunk heads.

The wedges are placed at an angle of approximately 23 deg. with the longitudinal center line of the truck frame. This position allows the longitudinal center lines of the wedges to approximate the arc of a circle whose radius is the distance from the center of the engine truck radius bar pin to the center of the wedges. When the locomotive is rounding a curve this permits of continuous contact between the top and bottom wedges under all conditions.

Integral with the bottom wedge tie, or frame casting, are two stops. These are reinforced by heavy ribs. The stops are located at the back of the frame and their duty is to engage with similar stops integral with the upper wedge tie and thus restrict excessive lateral movement under abnormal conditions.

The upper wedge tie is also a well ribbed steel casting to which the top wedges are fastened in the same manner as to the





frame casting. This upper tie extends up and into the front foot plate of the engine and is guided thereby.

The tie, rectangular in shape, has a  $\frac{1}{2}$  in. brass liner riveted at each end. These brass liners are  $13\frac{1}{2}$  in. long by 7 in. wide, and take the frictional load between the tie and similar liners bolted to the inner sides of the front foot plate.

The foot plate liners are held in place by a number of the bolts used to hold the front foot plate between the frames. The heads of the bolts in this case are flattened and countersunk.

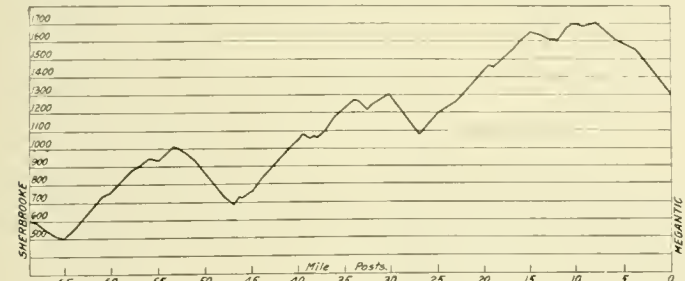

Profile of the Canadian Pacific Between Sherbrooke and Megantic

With this arrangement any lateral play that may develop can easily be taken up.

A number of hard grease cups, or receptacles, are cast integral with the upper wedge tie. At each end of the tie one of these receptacles is so located that holes drilled through the end wall form a passageway from the grease cavity to suitable openings through the brass liners. These openings in the liners are  $1\frac{1}{2}$  in. square, and form a pocket or reservoir, from which radiating grease grooves are cut.

Two other grease cavities are so cast and holes so drilled

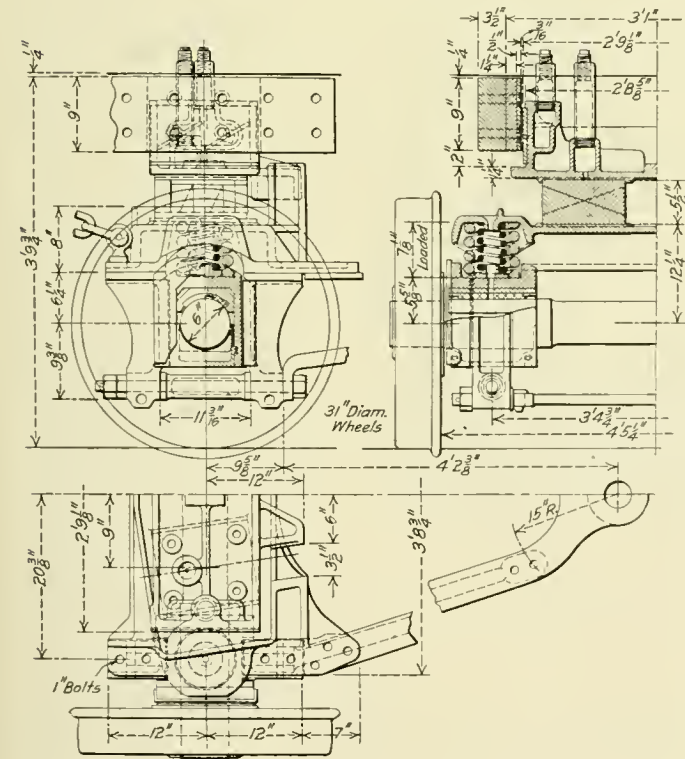

Arrangement of the Engine Truck of the Canadian Pacific Mikado

that grease can be forced from them to passages in the body of the upper wedges, these passages terminating at the wedge bearing faces. With this arrangement grease can be forced down and out between the friction faces of the wedges.

In both cases the cavities are tapped out and have screws in them cast iron extensions which pass through suitable holes

in the foot plate. Ordinary grease plugs are screwed in these extensions, enabling both the liners and wedges to be lubricated from the top and outside of the front foot plate.

Inspection of the illustration will show that each individual wedge possesses three distinct wearing faces. The two smaller, or outer faces, lie in the same plane and are inclined in one direction. The center face is inclined in the opposite direction. These faces are all inclined in their respective planes at an angle of approximately 22 deg. The sum of the areas of the two outer faces is equal to the area of the center face. With the top wedges in the central position, and superimposed on the bottom ones, all the frictional faces of the wedges are in contact.

Another interesting feature is the combined back steam chest cover and valve stem crosshead guide. The general arrangement of this device can best be noted from inspection of the accompanying photograph. It will be seen that the back steam chest cover, the valve stem crosshead guides, and the support for the rocker arm, through which the motion is transmitted to

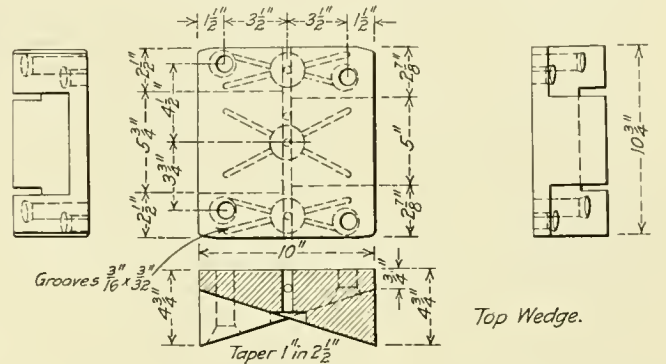

Top Wedge.

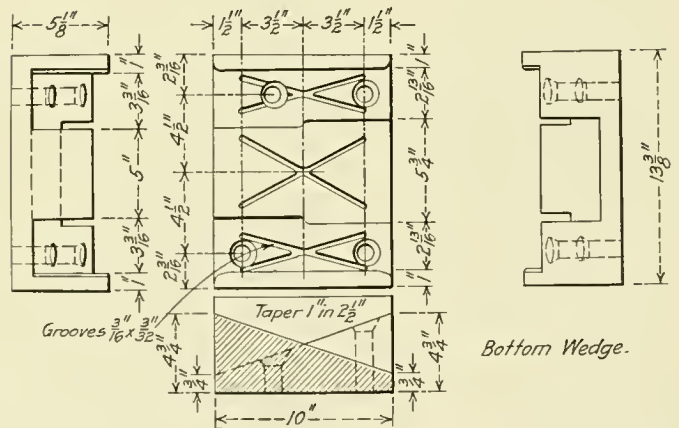

Bottom Wedge.

Engine Truck Wedges Used on the Canadian Pacific Mikado

the valve stem, are combined in one casting. This is a cast iron structure adequately ribbed and well proportioned. This casting supports a double armed rocker, whose arms extend downward.

The valve stem crosshead block is held by a  $1\frac{13}{16}$  in. pin passing through the extremities of these arms. The weight of the combination lever and radius rod is carried on an extension of this pin, which is  $2\frac{1}{4}$  in. in diameter at the point where it passes through the combination lever. The rocker arm is likewise a single casting supported by two journals  $3\frac{1}{64}$  in. in length and 4 in. in diameter. The use of the large journals and large motion pins tends to minimize the wear.

The chief object of this construction has been to provide a rigid support for the valve stem guide. The device not only accomplishes this purpose, but relieves the valve stem from any downward thrust due to the movement and weight of the parts of the valve gear to which it is connected. Should any excessive wear develop in the pins or guides, the result is the same. With some modifications this arrangement is similar to the one



described in detail in the American Engineer and Railroad Journal, January, 1908, about which time the device had its inception. Since that time it has been so economical to maintain, and has proved its merit so conclusively that it has come into general use on the Canadian Pacific.

These locomotives are all equipped with the vestibule cab which completely encloses the deck space between the engine and tender, and protects the enginemen from the intense cold that prevails at times. These cabs are the same as those previously described in these columns (March, 1913, page 117) with the exception that the front doors have been eliminated and windows substituted. The front cab doors became an obsolete passage way with the advent of the extended running boards and the extended handrails above the side windows. The runboards extend 3 in. from the outside of the cab below the side windows. In conjunction with the handrail above the side windows, they make the front runboards easier of access than through the previously existing front doors, which could only be reached through a narrow passageway partially obstructed by piping. That the vestibule cab has proved its merit is evinced by the fact that at the present time 207 Canadian Pacific locomotives are so equipped.

The tenders are the type in which the underframe and tank are an integral and self supporting structure. The general features of this design were also described in the article mentioned above. This type has proved so economical and so easy of fabrication that it has been made standard on the Canadian Pacific. The coal space has a capacity of 16 tons, and all of these tenders are equipped with air actuated coal pushers of the hinged type. A very large percentage of all the engines on this road have tenders equipped with this type of pusher. The tanks have

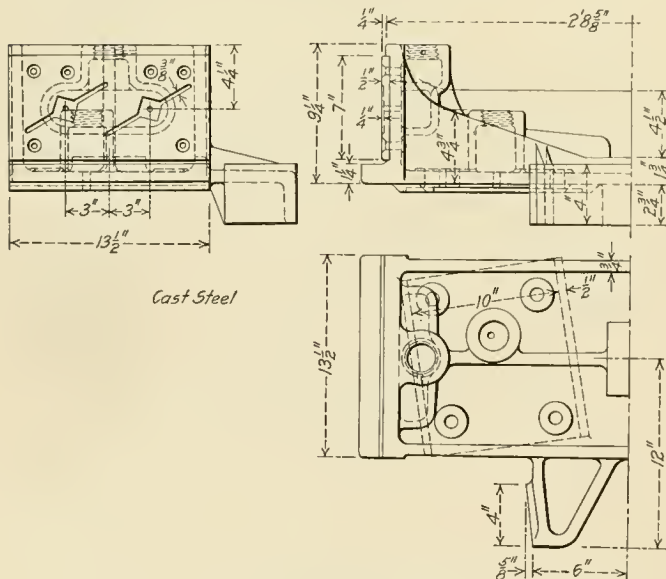

Engine Truck Bolster Gulde, Canadian Pacific Mikado

a capacity of 7,000 Imperial gallons, equivalent to approximately 8,500 U. S. gallons.

These engines are all equipped with the Vaughan-Horsley superheater. They are also equipped with screw reverse gear and Westinghouse 8 1/2 in. cross compound pumps.

The general dimensions, weights and ratios are as follows:

General Data

Gage.....	4 ft. 8 1/2 in.
Service.....	Freight and passenger
Fuel.....	Bituminous coal
Tractive effort.....	42,000 lb.
Weight in working order.....	258,000 lb.
Weight on drivers.....	198,000 lb.
Weight on leading truck.....	25,000 lb.
Weight on trailing truck.....	35,000 lb.
Weight of engine and tender in working order.....	428,000 lb.
Wheel base, driving.....	16 ft. 6 in.

Wheel base, total engine.....	35 ft. 5 in.
Wheel base, engine and tender.....	66 ft. 5 in.

Ratios

Weight on drivers ÷ tractive effort.....	4.70
Total weight ÷ tractive effort.....	61.50
Tractive effort × diam. drivers ÷ heating surface*.....	560.00
Total equivalent heating surface* ÷ grate area.....	94.70
Firebox heating surface ÷ total equivalent heating surface, per cent.....	3.97
Weight on drivers ÷ total equivalent heating surface.....	41.80
Total weight ÷ total heating surface*.....	54.50
Total heating surface* ÷ volume of cylinders.....	294.00
Grate area ÷ volume of cylinders.....	3.11

Cylinders

Kind.....	Simple
Diameter and stroke.....	23 1/2 in. x 32 in.

Valves

Kind.....	Piston
Diameter.....	12 in.

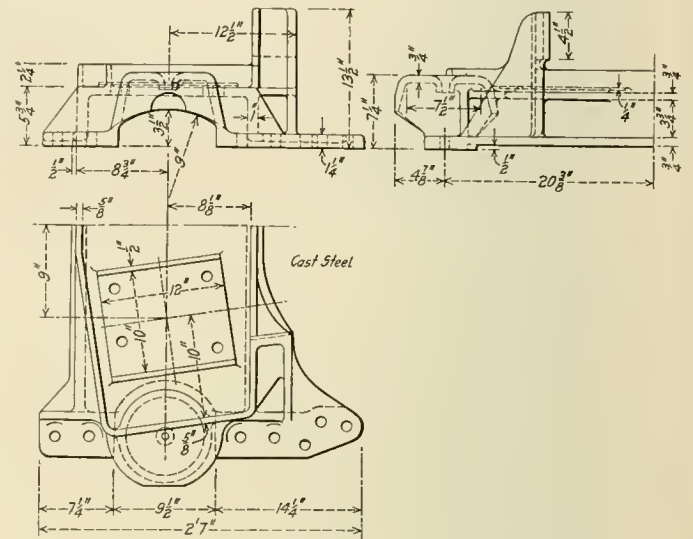

Engine Truck Frame, Canadian Pacific Mikado

Greatest travel.....	6 in.
Lap.....	1 in.
Inside clearance.....	Line and line
Lead.....	1/4 in.
Type of valve gear.....	Walschaert

Wheels

Driving, diameter over tires.....	63 in.
Driving, thickness of tire.....	3 1/2 in.
Journals, main, diameter and length.....	10 in. x 14 in.
Journals, others, diameter and length.....	9 1/2 in. x 14 in.
Engine truck wheels, diameter.....	31 in.
Engine truck journals.....	6 in. x 11 in.
Trailing truck wheels, diameter.....	45 in.
Trailing truck journals.....	7 in. x 14 in.

Boiler

Style.....	Extended wagon top
Working pressure.....	180 lb.
Outside diameter first ring.....	72 in.
Outside diameter dome course.....	79 in.
Firebox, length and width, inside.....	8 ft. 7 1/4 in. x 5 ft. 9 7/8 in.
Firebox plates, thickness.....	1/2 in., 5/16 in. and 3/8 in.
Firebox water space.....	Front, 5 in.; Sides, 4 1/2 in.; Back, 3 1/2 in.
Tubes, number and diameter.....	210—2 1/2 in.
Flues, number and diameter.....	30—5 1/2 in.
Tubes, thickness.....	No. 11 B. W. G.
Flues, thickness.....	No. 8 B. W. G.
Length over tube sheets.....	20 ft. 8 1/2 in.
Heating surface, tubes.....	3,410 sq. ft.
Heating surface, firebox.....	188 sq. ft.
Total fire heating surface.....	3,598 sq. ft.
Superheating surface.....	760 sq. ft.
Total equivalent heating surface.....	4,738 sq. ft.
Grate area.....	50 sq. ft.
Superheater, kind.....	Vaughan-Horsley
Center of boiler above rail.....	116 1/16 in.

Tender

Wheels, diameter.....	36 1/4 in.
Journals, diameter and length.....	6 in. x 11 in.
Water capacity.....	7,000 Imperial gal.
Coal capacity.....	16 tons

\*Total equivalent heating surface.

RECORD LOADING OF A STEAMER.—What is surely a record for speedy loading is that held by the Great Lakes steamship William E. Corey, which, at Two Harbors, Minnesota, took 10,100 tons of iron ore into her hold in 28 minutes. The Corey is of the hopper bottom type.—Scientific American.

# CAREER OF GEORGE WESTINGHOUSE

The World Loses in Him a Great Engineer, a Distinguished Scientist and an Exemplary Citizen

George Westinghouse, inventor of the air brake for railroad trains, inventor and developer in many other mechanical and electrical fields, philanthropist, and one of the chief citizens of the United States, died at his apartments in New York City, March 12, of heart disease, having been confined to his room for about three months; previous to which time he had been for some months at his country house in Lenox, Mass. The fatal malady began to show itself over a year ago, and he had gradually withdrawn from all business activities. He is survived by his wife and by one son, George W., Jr., a graduate of Yale and recently married. The body was buried at Woodlawn Cemetery, New York City.

The will of Mr. Westinghouse provides for the continuation of his large business interests under a trusteeship, and his death will bring no change in the administration of any of the numerous important concerns of which he had been the leader.

The great and outstanding invention of Mr. Westinghouse is the air brake. By this his name was carried all over America before he was 25 years old, and all over the world before he was 35. His later inventions are less known because they are less easily comprehensible and because the world is now so full of other wonders; but the benefits which they confer on mankind are immeasurable. In his intense and catholic devotion to the genuine progress of civilization, as distinguished from mere personal glory or aggrandizement, Mr. Westinghouse was as much of a developer as an inventor; as truly enthusiastic in carrying out others' ideas as his own; and his notable contributions to general progress include electric lamps; long distance electric power transmission, made possible

only by means of his development of the alternating current; the steam turbine; the friction draft gear and the wide utilization of natural gas.

A survey of Mr. Westinghouse's activities in these several fields, beginning back in the later seventies, as soon as the complete success of the air brake was assured, makes clear the unique and outstanding genius of the man; namely, the sanity and vigor with which constantly, year after year, he devoted his brilliant talents and his unbounded energies always in the most useful channels available. As the small or weak man seeks constantly the line of least resistance, this giant constantly took the opposite course. He aimed to throw the whole force of his own ability, the talents of his assistants and the facilities of his great shops and laboratories into that line where the world most needed those abilities, talents and facilities. And, though he was not free

from mistakes, his mind was so active and fertile, his perceptions so wise, that he kept in the front rank of progress throughout the 40 years of his active career. Unlike many mechanical geniuses, he was large hearted and human; a philanthropist who elevated the lives of his workmen. The verdict of history will recognize the unique combination; a mechanic possessed of genius, a versatile scientist and thinker of the first rank, and a humane "business man." Not the smallest element in the success with which he carried out his purposes in these diverse lines was the loyal co-operation of his brother, Henry Herman Westinghouse, and

of other lifelong coadjutors, whom he selected with unusual insight and rewarded with liberality.

George Westinghouse was born in the village of Central Bridge, New York, October 6, 1846. His father, George Westinghouse, who came from Vermont, was of German descent, and his mother's ancestors were Dutch-English. The elder Westinghouse established in Schenectady, in 1856, the Schenectady Agricultural Works; and in the father's shops the boy spent much of his leisure time. Before he was 15 he invented and made a rotary engine and at an early age passed the examination for the position of assistant engineer in the United States Navy. He served in the army in the Civil War, first in the 12th New York National Guard and later as third assistant engineer in the navy. At the close of the war, resisting solicitations to remain in the navy, he entered Union College, Schenectady, but at the end of his sophomore year he abandoned his classical studies and entered on his active life. It is said that the president of the college in substance advised him to take that course, predicting that in the course of time he would

become a great engineer. Indeed, even before this, in 1865, he had made his first railroad invention, a cast steel re-railing frog.

## THE AIR BRAKE

The air brake, like the re-railing frog, was suggested by actual necessity as shown by a train accident, in 1866. Westinghouse first thought of a brake attached to the car couplers, but this, when tried, proved impracticable. Next he tried steam, which was not a success. At this point, Fate seems to have entered his life. In the pages of a magazine to which he had subscribed through the solicitation of a young woman, he saw an account of the use of compressed air in drilling the Mont Cenis tunnel; and instantly the inventor saw the light. After much reflection, drawings of the air-pump, brake cylinder and valves were made, and a caveat was filed in 1867; but it was not for a considerable time



Copyright by Gessford, N. Y.

George Westinghouse



after this that he was able to make a trial of the brake. He moved to Pittsburgh; and there he finally secured the aid of Ralph Baggaley, who guaranteed the payment of the foundry bill for the first apparatus. This was in 1868. The brake was tried on the Steubenville accommodation train of the Pittsburgh, Cincinnati & St. Louis. It received its initial trial unexpectedly on its very first run. The engineman, seeing a wagon stuck on a crossing not very far ahead, applied the air. Like everybody else, he was not free from skepticism; but the brake averted an accident and its popularity was thenceforth assured.

The first patent was issued April 13, 1869. The Westinghouse Air Brake Company was formed on the 20th of July, following. The first shop was established with 20 workmen. In the autumn of 1869 a demonstration was made on the Altoona grade for the Master Mechanics' Association, in connection with the annual meeting of the association.

The success of the brake—which was the "straight air"—on the Pittsburgh, Cincinnati & St. Louis, led a number of other roads to make applications and soon it was known throughout the country. There had been experiments with chain brakes before, and considerable sums had been spent on coil spring arrangements and other notions, but the compressed air brake was the first device of the kind that had a lasting success. The slight competition of the vacuum brake had but a brief influence.

In 1870, Mr. Westinghouse went to London to introduce the air brake on the English roads. This was a difficult problem, as the usual practice in Europe was to have no brakes at all, not even hand brakes, except on the brake vans and tenders. This enterprise required the spending of seven years in Europe between the years 1871 and 1882. It taxed the inventor's ability to meet conditions; but he introduced the brake on passenger trains on a number of prominent roads.

But the greatest triumph was the advent of the automatic brake in 1872-73. The original or straight air system was dependent on the integrity of the car couplings. With the "automatic" and its wonderful triple valve, the line of pipe through the train was normally filled with air at 70 lb. pressure and the *release* of this pressure caused the application of the brakes; and of course the breakage of a car coupling, causing the parting of a train, applied the brakes and stopped the separated parts.

And this invention of the triple valve, to meet the first great obstacle encountered in the pursuit of a perfect braking system, was only the beginning of a series of inventions which solved the difficulties incident to the successive enormous increases in weight, length and speed of trains. If a new problem, or series of problems, demanded the inventor's application for 17 hours a day for successive months, or if elaborate and complicated details called for the work of a dozen of the most expert specialists simultaneously, the resources of the Westinghouse establishment were devoted to the task and it was accomplished.

In 1886-87 the "quick action" brake was brought out. The air brake had at first been introduced only on passenger trains. On the mountain railroads of the West, its value was soon demonstrated on freight trains also; and from these roads it spread slowly to the other parts of the country, so it came about that the inventor was confronted with an entirely new problem, that of braking very long trains. But with a fifty-car train, the cars in the front portion were stopped much sooner than those in the rear portion, so that when the slack ran in, there was a small collision—or perhaps a serious smash-up. The elaborate three-weeks' trials on the Burlington road near Burlington, Iowa, in 1886, under the direction of the Rhodes Committee, form a prominent page in American railroad history. At the completion of these trials the conclusion was quite general that electricity would afford the only possible means of controlling power brakes on long trains; but Mr. Westinghouse determined, if possible, to adapt the air brake to the new conditions; and he triumphed. If the original triple valve was an epoch-making invention, this modification of it was only second in importance.

The triple valve had reduced the time for the application of the

brakes on the whole of a ten-car train, as compared with the straight air, from 25 seconds to 8 seconds; and now the power was made to act throughout a train of 50 cars in 2 to 3 seconds. It was in October and November, 1887, that the exhibit train of 50 freight cars made its triumphal tour of the United States. Railroad men were amazed when they saw a loaded freight train, 1,700 feet long, running at 40 miles an hour, brought to a stop in less than 600 feet. In 1869-70, the wonder had been in seeing a train stopped apparently by an unseen power; in 1887, the wonder took the shape of a striking display of power. As compared with former performances, the stoppage of a train by the new apparatus appeared to be a manifestation of energy on an incredible scale.

#### HONORS

His many achievements in mechanics, electricity, steam and gas brought Mr. Westinghouse honorable distinctions from all parts of the world. His alma mater, Union College, conferred upon him the degree of doctor of philosophy. He was decorated with the order of the Legion of Honor, with the order of the Royal Crown of Italy, and with the order of Leopold of Belgium. He was the second recipient of the John Fritz medal. He received the degree of doctor of engineering from the Koenigliche Technische Hochschule of Berlin. He was an honorary member of the American Society of Mechanical Engineers, of which body he was president in 1910. The archives of that company contain the authentic history of the air brake. He was awarded the Scott premium and medal by the Franklin Institute of Pennsylvania, and received the Edison gold medal for meritorious achievements in the alternating current system of electrical distribution. He received the Grashof gold medal from the Society of German Engineers in Germany, which acknowledged him the greatest American engineer.

A partial list of the industries in which he was an officer or leader includes the Westinghouse Air Brake Company; the Westinghouse Machine Company; the Nernst Lamp Company; The Union Switch & Signal Company; the Societe Anonyme Westinghouse, Paris; the Cooper Hewitt Electric Company; the Societe Italiana Westinghouse, Italy; The East Pittsburgh Improvement Company; the Westinghouse Brake Company, Limited, of London; Westinghouse Cooper Hewitt Company, London; the Westinghouse Friction Draft Gear Company, and the Westinghouse Metal Filament Lamp Company, Limited, London. He was also chairman of the board of directors of Westinghouse Electric Company, Limited, London, and a director in the Westinghouse Metallfaden Gluhlampenfabrik, Vienna.

The Westinghouse companies altogether employ 50,000 men and the total capitalization of all the companies is \$200,000,000.

#### PERSONAL CHARACTERISTICS

Mr. Westinghouse's biographer will have to devote one of his largest chapters to the man's personality, from what might be called the non-technical side. His kind heart was a worthy complement of his phenomenal mind. It is recorded that in his first shop, started in 1869, he introduced the fifty-four-hour week and the Saturday half-holiday, at that time new things in America. Of the Employees' Association at the air brake village he was not only a member, but a regular attendant. He was a pioneer in providing model dwellings for the employees of the shops on a large scale, and at reasonable prices. Young inventors whom he aided spoke of him not only as a wise and powerful supporter, but as a sympathetic friend.

He was a man of great physical strength, six feet tall, and lived an abstemious and sober life; never smoked, and ate and drank sparingly. Change of work constituted his principal diversion; he was too modest and serious to care much for "society."

It was these qualities which enabled him, in the strenuous contests with rival inventors and contractors which attended his electrical enterprises, to accomplish mental tasks which to the ordinary mind are incomprehensible in their magnitude.

## COMPOUND LOCOMOTIVES

The Railway Gazette, London, England, prints the following from a correspondent on the subject of compound locomotives:

The fact that compound engines can be made to develop much greater power than the simple engine when each uses the same weight of steam will no doubt have caused considerable surprise to the uninitiated as to why the compound locomotive failed to fulfill its promise and why a certain railway converted all its compounds back to simple. Yet the explanation is very simple.

In the first place, it must be borne in mind that the tractive effort of a locomotive must never exceed its adhesive weight. Now it must be obvious that if two engines are designed to develop the same tractive effort it becomes impracticable with existing designing of locomotives to make the compound engine more powerful than the simple engine. The very fact of restricting the power of the former thus defeats the object of compounding; curiously enough there is a very simple way out of the difficulty. For instance, the tractive effort of a locomotive is based on its maximum starting effort when the lever is in full gear, a condition under which it is never called on to do regular duty. It is therefore only necessary to base the tractive effort with a cut off in the high pressure cylinders, and where enginemen usually work—somewhere about 30 per cent of the stroke of the piston—to effect an important improvement in favor compounding, for it at once becomes impracticable to design a simple engine which can compete with it.

The maximum power of the simple engine would be when working with a 75 per cent cut off in the cylinders, and the maximum power of the compound when working with a 30 per cent cut off in the high pressure cylinders.

It would, of course, be open to locomotive designers to produce a simple engine which would have a tractive effort equal to the adhesive weight of the engine when working with a 30 per cent cut off by using four large cylinders.

## SERVICE OF VANADIUM STEEL TIRES

The Western Maryland applied a set of heat-treated chrome-vanadium steel tires to a Pacific type locomotive in April of last year. Contours were taken this month, after 11 months' service, and comparison between the performance and the average for three sets of plain carbon steel tires on sister engines running in the same district show an increase of 148 per cent in mileage per 1/16 in. maximum tread wear in favor of the vanadium steel tires.

Up to March 1, the vanadium steel tires had made 49,096 miles. The maximum tread wear was 3/16 in., or 16,365 miles per 1/16 in. maximum wear. The three engines equipped with carbon steel tires showed respectively 5,393, 6,140 and 7,250 miles per 1/16 in. maximum tread wear, or an average of 6,594 miles per unit of maximum wear.

The service of the vanadium steel tires is shown by the ac-

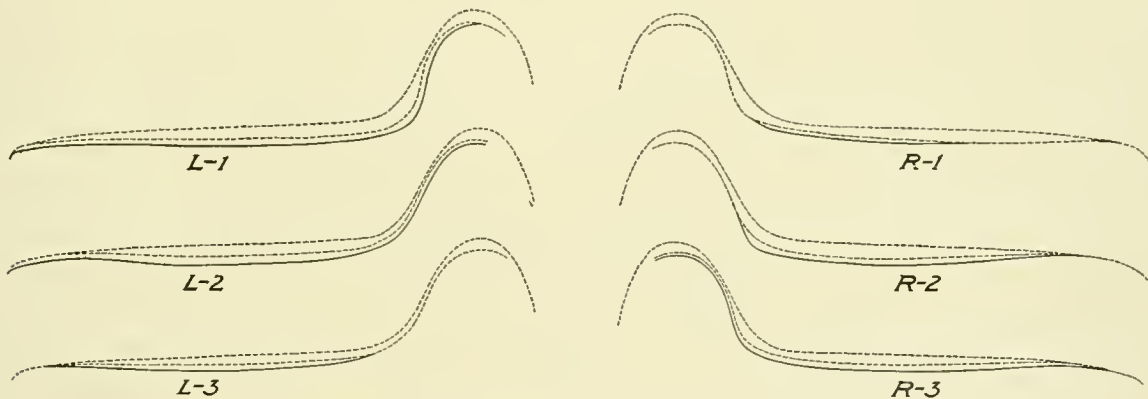

Contours of Western Maryland Vanadium Steel Tires

If locomotive designers are going to take up the question of compounding seriously, let them combine and have one experimental engine made which will be the counterpart of one of the best types of simple engines now at work, viz., one with 19 in. by 26 in. cylinders; let the equivalent of two cylinders 30 in. in diameter be placed between the frames. They will then have a compound which can be worked in every respect similar to a simple engine, both as regards starting a train and in linking up to an early cut off in the high pressure cylinders; it will, moreover, in every case, and under all conditions, deal with a load in every respect similar to a simple engine, even to making use of steam heated up to the highest temperature practicable.

It may be objected that a compound engine with two 19 in. high pressure and two 30 in. low pressure cylinders would give a tractive effort far in excess of the adhesive weight when the high pressure valve gear was full over. If, however, the engineman cannot be trusted to place the lever at 30 per cent cut off soon after the engine moves, it is only necessary to have notches in the quadrant for a 30 per cent cut off. A small cylinder can be connected to the reversing arm and connected to the low pressure receiver, so that while the latter was being charged with steam from the exhaust of the high pressure it would act on the piston and place the high pressure lever at 30 per cent so that the engineman could never work with a later cut off.

companying illustration. This shows the present contours and contours taken in October after six months' service superimposed on each other and also on the original contour to which the tires were rolled. The full line represents the present contour and the middle dotted line the contour taken in October of last year. The flange wear is somewhat greater on the right than on the left tires. The tread wear, though quite uniform, shows if anything a little less wear in proportion during the last five months of service than during the first six months.

The Pacific type locomotive to which these tires are applied has a total weight in working order of 188,800 lb., with 122,600 lb. on drivers, or an average of 20,430 lb. per wheel. The rigid wheel base is 11 ft. 10 in., and the total engine wheel base 30 ft. 4½ in. The tires are 62 in. inside diameter and 3 in. thick. The chemical composition and physical properties were as follows:

CHEMICAL COMPOSITION	
Carbon .....	.055 per cent
Manganese .....	.074 per cent
Chromium .....	.089 per cent
Silicon .....	.035 per cent
Vanadium .....	.028 per cent
Phosphorus .....	.0039 per cent
Sulphur .....	.0025 per cent
PHYSICAL PROPERTIES (AFTER HEAT-TREATMENT.)	
Elastic limit, lb. per sq. in. ....	111,000
Tensile strength, lb. per sq. in. ....	153,500
Elongation in 2 in., per cent. ....	13.5
Reduction of area, per cent. ....	42.5



TYPICAL EXAMPLES OF RECENT PASSENGER LOCOMOTIVES

ARRANGED IN ORDER OF TOTAL WEIGHT

ATLANTIC, TEN-WHEEL, MOGUL AND SWITCHING TYPES

Table with multiple columns: Type, Name of road, Road number or class, Builder, When built, Tractive effort, Weight, Weight on drivers, Weight on truck, Weight on trailer, Weight on tender, Wheel base, Wheel base, engine and tender, Diameter of drivers, Cylinders, Cylinders, Valve gear, Steam pressure, Boiler, Boiler, Tubes, Length of tubes, Heating surface, Heating surface, Heating surface, Grate area, Firebox, Firebox, Kind of fuel, Tender, Tender, Weight on drivers, Evap. heat, Firebox heat, Total heat, Total weight, Total weight, Total heat, Grate area, Reference for photograph, drawings or description.

\*Locomotive Dictionary.





### WATERING THE RAILS TO PREVENT SLIPPING

Watering the tires and greasing the flanges of locomotive wheels are two operations which are carried out by similar means, but which have totally different effects. The first is intended to increase the adhesion between wheels and rails; the second is intended to reduce the friction between wheel flanges and rails on curves. Unless great care is taken in the use of such watering or greasing devices, there is a considerable risk of obtaining an effect contrary to that desired.

Locomotives are designed to have sufficient adhesion; nevertheless this may occasionally become reduced so that the wheels slip. This generally happens in starting, or on long up-gradients, or in tunnels, or in certain atmospheric conditions. Several methods have been devised for remedying this want of adhesion. The most usual one is to run sand on the rails. In recent years, instead of this method for which absolutely dry sand is required, steam sand-sprayers have been used which project wet sand on the rails. But there are serious disadvantages when it has frequently to be used at the same places, and attempts have been made to do without it and replace it by watering the rails.

Numerous cases of wear on the rails due to the action of sand have been observed at many places, in particular in the Hauenstein tunnel, 1.86 miles from Olten, Switzerland, where the rails laid in the end of 1870 showed the following renewals, when the five years' guarantee expired:

Rails laid in the tunnel.....	111.76 per cent
Rails laid outside tunnel.....	1.66 per cent

In this tunnel the use of sand has been entirely eliminated, and a jet of water is used instead; this has given excellent results.

There is a phenomenon well known to all enginemen: when the rails are damp, in times of fog, the locomotive wheels slip; while if heavy rain wets the rail thoroughly, no slipping takes place. Hence the method of watering the rails in order to avoid slipping at once suggests itself.

In 1859, locomotives of the classic Bourbon type were fitted with a cock and a pipe which made it possible to send water under pressure to the rails.

At the meeting of the Société des ingénieurs civils, held on May 7, 1875, Mr. Mallet stated that no sand, but a strong jet of water which washes the rails perfectly, was used on the railway which runs from Zurich to the top of the Uetliberg.

About thirty years ago the transport of iron ore in the Mazeray mines, belonging to the Creusot firm, was effected in the Sainte-Marguerite heading, by means of small locomotives, which worked very well, except on an up-gradient, 394 yd. in length, where there was much trouble in consequence of the slipping of wheels. This caused delays and irregularities in the service, increased consumption of fuel, and excessive wear of the tires. A lucky chance showed how these troubles could be prevented. The blow-off cocks of the cylinders started leaking, and the escaping steam happened to strike the rails, so that these were cleaned; the slipping at once stopped. Struck by this unexpected result, the engineer in charge of the locomotive department had the blow-off cocks altered in such a way that they discharged straight at the rails. At the moment the up-gradient was reached, the cocks were opened a little, the rails were cleaned and the train ascended without trouble. The traffic (80 to 100 tons per day) had cost 0.227 franc per ton per kilometer for traction; this cost was reduced to 0.012 franc by the mere alteration of the blow-off cocks.

Theory and practice agree that washing the rails is an effective means for preventing slipping. Attention must, however, be given to the consideration that mere wetting does not suffice; on several railways it has been observed that this reduced the adhesion rather than increased it, because too

little water, or water at too low a pressure was used. The best results have, on the contrary, been obtained by using a strong jet of water able to wash off the rails any dirt which was sticking to their running surface.

A useful effect can be obtained by using the blow-off cocks of the cylinders, as in the instance of the Creusot locomotive mentioned above, but it is only possible to use them in the case of locomotives making very short runs, such as mine locomotives.

In the case of an ordinary railway, a special appliance is required. This appliance can be arranged, according to circumstances, either to take the water and steam required from the boiler direct, or to take live steam from the boiler and water from the tank, or to utilize the exhaust steam from the locomotive and water from the tank.

In an appliance of this kind, which is of a simple character, water is taken from the boiler through a cock operated by a rod, the handle of which is within reach of the engineman. The liquid, under pressure, passes through this cock and through a pipe carried down outside the boiler to a tee piece placed centrally; there the current divides and passes into two horizontal pipes, the ends of which are bent down and fitted with nozzles, from which issue the jets washing the rails.

The way in which this appliance is supported deserves special mention. Locomotives running on lines with sharp curves generally have axles with lateral play and the displacement of the frame of the locomotives relatively to the track is generally rather considerable, hence the nozzles must not be fixed to the frame or else the jets would frequently miss the rails. It is, on the contrary, necessary to connect them with the axle, as its wheels necessarily remain in the same position relatively to the track. In the case of this appliance, a triangle supporting the tee piece is hung from the axle and moves with it. The nozzles are hung from the frame, but by means of rods and swing links, a construction which enables them to move with the axle and to remain always directed at the rails.

The appliance which has just been described consumes much water and steam, and this gives rise to trouble if the boiler is not very powerful. Hence attempts have been made to take water from the tender and to take from the boiler only the steam necessary to give the water the velocity required. This method has been applied on the locomotives used in the Hauenstein tunnel.

These locomotives were fitted with a steam cock placed on a branch from the whistle tube, a water cock fitted to the water tank, an ejector in which the steam pipe and water pipe just mentioned terminate, and the pipe from the ejector, leading the mixture of the steam and water to the front of the locomotive. This pipe divides into two branches, each ending in a nozzle placed 2 3/8 in. above the rail and inclined at an angle of 15 deg. to the vertical.

The consumption of water was about 11 English gal. per minute, with an ejector having a steam pipe of 7/32 in., a water adjustage of 13/64 in. and a divergent cone of 3/16 in. The bore of the pipe from the ejector to the tee piece was 1 13/16 in., and that of the branches 31/32 in. Finally the nozzle projecting the water on the rail had a diameter of 5/32 in.

With this appliance it was possible, on a straight track, to project on the rails a jet of water having a temperature of 60 deg. C. (140 deg. Fahr.) and a velocity of 91.87 ft. per second; this suffices for a thorough cleaning of the running surface of the rails.

Instead of using live steam for working the ejector, exhaust steam may be used; in that case, no extra steam is required.

The exhaust from the cylinders of the locomotive gives a strong enough jet to propel the water for washing the rails, but the exhaust from the air pump is not sufficiently strong for the purpose.—*Bulletin of the International Railway Congress.*

# CAR DEPARTMENT

## FREIGHT CAR REPAIRS\*

BY G. L. BUNDY

General Foreman, Delaware, Lackawanna & Western, Kingsland, N. J.

In the December, 1913, number of the Railway Age Gazette, Mechanical Edition, appeared the question (among others) "If a damaged car comes on the repair track with a number of parts broken in fair usage, is it wisdom or economy to replace the broken parts with the same design and construction?" As a mechanical man who has had a number of years' experience in the car department, I should say this would be poor practice. If the parts failed in fair usage, there could be no assurance that they would not fail again before the car reached the next divisional point.

Railroad officers have watched the growing cost of repairs to freight cars for a number of years, and it can be attributed to a number of reasons:

First, the rapid introduction of heavy power during the past few years. The railroads had in use a large number of cars, built prior to the introduction of this heavy power, of wooden construction and with short draft timbers extending back only to the body bolster. When these cars were built the power was light and 30 cars was considered an average train; but today trains have increased to 60 and 80 cars and some railroads still maintain their old cars as they were originally built. Such cars will not stand up in the heavy trains of the present day.

Second, we find these light cars switched in trains indiscriminately, and going over the road badly sagged and leaking grain in many places. If these cars were favored by being placed at the rear of trains, it would result in less failures, but this would entail an additional expense in switching and would, no doubt, meet with many objections from the operating department.

The third most important cause of the high cost of repairs to freight cars is the starting of trains where it is necessary to take the slack a number of times before they can be gotten under way. This results in much damage, especially to couplers, draft timbers, center sills and end sills. Cars are also frequently damaged in terminals in switching over hump yards.

These, I think, are the main reasons for the many failures and the high cost of repairs to freight cars. As the heavy power has proved to be the most economical from an operating standpoint and has come to stay, why not build or rebuild our freight cars so that they will stand the service? If we do this, in a short time the cost line, instead of going up will turn downward until it finds the lower level to which it belongs.

My experience has showed that the most frequent parts to fail on freight cars are draft timbers, draft gears of the old spring type, couplers, coupler rivets, longitudinal sills and end sills. This being the case, it proves conclusively that these are the parts that should be strengthened. Railroads should, in my opinion, select such of their equipment as it will pay to spend money on and put it in condition to stand the conditions of modern service.

The first and most important thing to do is to apply steel underframes. The next consideration is the draft gear. There are many failures of other parts that can be attributed to an inadequate draft gear. I believe there are about three-fourths of the freight cars in service today equipped with the old spring type draft gear with a capacity not over 20,000 lb., and these cars are still being maintained—just why, I am unable to explain, unless the first cost is less than that of the friction draft

gear. If this is the case the difference in cost is soon thrown away in the maintenance of the spring gear, to say nothing of the cost of the many other parts that require repairs on account of inadequate draft gears.

The ends of old wooden cars are a source of trouble. The end posts, being tenoned into the end sills and end plates, offer little resistance to shifting loads and are often pushed out in ordinary switching. These should not be maintained as originally built, but should be strengthened by putting in the all metal corrugated steel end or by replacing the old posts and braces with metal ones sufficiently strong to withstand the shifting of loads in switching service.

The side door is another part of the car that has been provided with inadequate fixtures. Many cars are found with wooden door stops lagged or bolted to the door post and the seal lock bolted on the stop with two  $\frac{3}{8}$  in. bolts. The result is that the stop becomes split from the shocks in ordinary switching service. The door hasps are secured to the door with a  $\frac{3}{8}$  in. bolt, resulting in the door siding giving way. Many doors are also damaged at the loading platforms, by being opened, when warped, with bars and sledges. To maintain doors of this design helps greatly to run up the cost of repairs, renewing these parts as often as it must be done. The door stop should be of metal and the seal lock riveted on, and the hasp should be secured to a metal strip running back at least one-half the width of the door. Angle irons should be bolted across the door to prevent its warping, and the bottom of the door should be protected with an angle iron to prevent wear against the guide brackets. In addition to this the doors should be made secure, if for no other reason than that they are liable to fall off or swing out at the bottom, striking passenger trains and injuring passengers. At this time, when the safety first movement is being taken up by all railroads, this matter should be taken up vigorously and the side door put in condition to perform its duty in a more satisfactory manner than it has done in the past.

Another part of the freight car which has cost railroads large sums of money to maintain is the roof. There are varied opinions among car men as to the best construction for car roofs. Looking back a few years, the major portion of the cars built had the double board roof, well painted between the two courses; a little later, some of the roads applied a heavy plastic roofing paper between the boards. This style of roof proved unsatisfactory, as the boards would shrink and water would find its way down around the nails, which had become loose, due to the weaving movement of the car.

Then came into use, and especially on refrigerator cars, the roof called the torsion proof paper roof. The paper was applied in sheets, the top ends overlapped each other at the ridge pole and the sides of the sheets were set in a groove in the sub-carline. This roof was not a success as the sheets were continually getting out of place and causing leakage.

Next came the metal roof with the sheets extending across the car from side plate to side plate and nailed at the ends. This style of roof invariably gave way along the ridge pole and at the ends. It was followed by the inside metal roof with the sheets extending only to the ridge pole in the center of the car. This roof proved to be the best design and is used quite extensively at the present time.

However, in order to get as much clearance as possible, the outside metal roof was extensively used by many railroads. These roof sheets were laid on one course of boards, usually placed lengthwise of the car. The sheets overlapped each other at the top and along the sides and were secured to the side fascia by means of clips. This design was too rigid to accom-

\*Entered in the Car Department competition which closed February 1, 1914.



modate itself to the torsional movement of the car in service and would give way at the lower end, so that the wind and water would blow under the sheets. The result was that many claims were paid on account of goods damaged in transit, and it became general practice to make inspection of cars before loading with cement or other freight which is liable to damage on account of roofs leaking.

The all metal roof applied to cars of recent build looks to be a roof that will give satisfaction, but I do not think it advisable to apply this kind of roof to old wooden cars, as the superstructure is not sufficiently strong. However, I do think we should use on reconstructed cars the inside metal roof, which will accommodate itself to the weaving and torsional movement which these cars undergo.

I have dealt briefly with some of the most serious troubles with freight cars, and I am fully convinced that if the managements of our railroads would see the freight car in this same light and follow out the suggestions as to the kind of repairs we should make in bringing our cars into condition to meet the service, in a short time we would not only feel the good effect in the way of reduced maintenance costs, but we would also eliminate many of the delays to traffic due to cars failing in trains on the road. At the same time the claims resulting from defective side doors and leaky roofs would be greatly reduced. Railroad officers should rely on the mechanical men, who are handling the equipment and have the responsibility of keeping it in repairs. They are the best judges, in my opinion, as to what construction will last longest and give the best results, and help keep down the high cost of maintenance.

## THE CLASP BRAKE\*

BY F. M. BRINCKERHOFF

No greater safeguard against injury to passengers or rolling stock can be provided on a car than an adequate brake equipment.

While the power obtainable from the air brake cylinder can be increased to any desired extent, the means for effectively applying this force to the brake shoes and to secure maximum retardation, is a matter requiring thorough study in all details, both of foundation and truck brake gear.

In a recent test of a modern air brake equipment on cars fitted with clasp brakes, two shoes per wheel on all eight wheels, stops were made from speeds of 55 miles per hour in 16 seconds, during which the cars proceeded 720 ft. The cars tested are 72 ft. in length overall, and weigh, complete with motive power, 119,500 lb. each. As the electro-pneumatic brake equipment employed provides for the simultaneous application of the brakes on every car of the train, regardless of the train length, the above rate of braking would permit of bringing a train of ten such cars from a speed of 55 miles per hour to a standstill while traversing a distance equal to its own length. It is of interest also to remark that the tests referred to were protracted to the extent of making 258 test stops from speeds ranging from 30 miles per hour to 57 miles per hour. The total distance traveled during the tests was 270 miles.

The total brake shoe pressure per car in emergency stops was 174 per cent of the weight on the wheels. No wheel sliding occurred, and the emergency stops, while abrupt, did not disturb the standing observers, there being practically no reaction. Brake leverage ratio was 9 to 1.

As a matter of interest, the actual piston travel necessary to make full emergency application, running or standing, is  $3\frac{1}{2}$  in., though in operation the automatic slack adjuster is set to operate at 5 in.

Two brake cylinders per car are used to secure the power. Each truck has its own brake cylinder, foundation brake gear

and hand brake rigging complete, and entirely independent of the other truck except that both cylinders are supplied with air from the one control valve.

The purpose of the test was to determine the relative retardation efficiency of simple brakes and of clasp brakes for high speed service. It was found that about 18 per cent was gained in time of stop, and about the same in distance, by the use of clasp brakes instead of simple brakes. The two tests were absolutely identical as far as the brake rigging was concerned; the only change made was, that in the clasp brake tests we used two shoes per wheel and in the simple brake tests we used one shoe per wheel. The total shoe pressure per wheel was the same in both cases.

The cars are all equipped with two brake cylinders and with independent brake rigging for each truck, in order to leave the center of the car between the trucks free for the application of motive power control apparatus. Another reason for separating the brake rigging was to give a greater factor of safety for single car operation. If the brake rigging fails on one end of the car, there still remains half the braking power of the complete car on the other truck.

The simplicity of the hand brake rigging on this car is illustrated by the fact that 48 per cent of service brake power per truck can be obtained by the application of 100 lb. pull on the hand brake handle. This makes a good service stop.

Analysis of the weights of truck members as influenced by the design will disclose means for marked reduction in truck weight while in no way reducing the strength of the complete structure. The extensive use of passenger trucks without equalizer bars on a large steam railroad system warrants the full consideration of this type of truck, with a view to securing the marked reduction in weight possible with this construction.

In my estimation, trucks designed today should either be fitted with clasp brakes or be designed with provision for their ultimate application. It is seldom that a fully efficient clasp brake rigging can be applied to a truck designed for simple brakes. The best braking results will therefore be secured by designing the truck specially for clasp brakes, as otherwise the sacrifice of many features advantageous to the clasp brake system will have to be made later, on account of truck frame interferences or limitations.

Aside from the improved stopping capacity secured by the use of clasp brakes, there is a notable increase in mileage per shoe realized on account of the more efficient working temperature of the clasp shoe system, with its lower pressure per square inch of working surface. This saving appears, in regular service aggregating about two million car miles, to amount to approximately 18 per cent.

An incidental and very important result of the use of clasp brakes is the minimizing of hot journal troubles by their use. This is obviously due to the fact that during braking the two shoes press with equal force on opposite sides of the same wheel. There is, therefore, practically no disturbance of the journal brass, which consequently retains its accustomed accurate fit on the journal.

This same clasp action of the brake shoes relieves the journal boxes and pedestal guides of considerable of the strain and wear incident to the simple brake, and as there is no binding of the journal boxes in the guides when braking occurs, the riding quality of the truck is not affected at such times.

Stresses on journals will in like manner be materially reduced by the use of clasp brakes.

LOCOMOTIVE BOILER DESIGN.—The goal of boiler designers is to obtain the largest number of pounds of steam to each pound of metal in the boiler. The various studies and experiments have clearly indicated the advantage of the use of a longer flamework between the fuel bed and the end of the tubes, giving an opportunity for completing the gas reaction before the products of combustion enter the flues.—*Railway Age Gazette*.

\*From a paper read before the New England Railroad Club, February 10, 1914.

# NORTHERN PACIFIC STOCK CAR

## Strong End Construction and Combined Steel and Wood Underframe Which Employs Truss Rods

The Northern Pacific has recently placed in service 250 stock cars that have many interesting features. The cars were designed by the railway company and include standards that are common to all the box cars built for this road. While the cars were built



Interior of the Northern Pacific Stock Car

primarily for stock service they were made of sufficient strength to carry other commodities that could be conveniently carried in such a car. They are built with a combination steel and wooden

to the framing. All sharp corners are rounded and the large bolts are countersunk for the same reason. All lumber used throughout the construction is Oregon fir.

The underframe is of special interest, the design being the Northern Pacific standard for all wooden freight cars. It is made up of a fish-belly girder for a center sill and built-up steel bolsters and end sills, wooden side and intermediate sills, wooden needle beams 4 ft. 1 in. each side of the center of the car, and two truss rods, one under each side sill. The center sill is designed to take care of both the buffing strains and the bending strains due to the load. It extends the full length of the car and is of the double web type. Two 12 in., 20.5 lb. channels extend the full length of the car and form the upper chord of the girder; these channels take care of the buffing and draft strains. The depth of the girder at the center of the car is 29 $\frac{1}{4}$  in., which gives a section modulus of 240 around the horizontal neutral axis taken at that point. The web plates are  $\frac{1}{4}$  in. thick and are riveted to the webs of the channels. They extend between points 18 $\frac{3}{4}$  in. outside of the center line of the bolsters. The depth of these plates for 2 ft. 6 $\frac{3}{8}$  in. on each end is 11 $\frac{1}{2}$  in. They then taper to the maximum depth of 28 $\frac{1}{2}$  in., which is maintained for 4 ft. 9 in. each side of the center of the car. A 3 in. by 3 in. by  $\frac{3}{8}$  in. angle is used at the bottom of the plate for the connection to the bottom cover plate which is 18 $\frac{1}{2}$  in. wide and  $\frac{1}{4}$  in. thick. These plates and angles are 8 in. shorter than the web plates. The web plates are further stiffened at the limit of the maximum depth by 3 in. by 3 in. by  $\frac{3}{8}$  in. angles, 2 ft. 3 $\frac{3}{4}$  in. long, placed vertically on the inside of the web plates. The top cover plate



Stock Car of 80,000 lb. Capacity for the Northern Pacific

underframe, steel being used for the center sill, which is a fish-belly girder, the bolsters and the end sills. No nails are used in the body of the car up to a height that would come in contact with the cattle, carriage bolts being used to fasten the sheathing

for the center sill consists of two plates 19 in. by  $\frac{1}{4}$  in. and 11 ft. 1 $\frac{1}{2}$  in. long, and three tie plates 19 in. by  $\frac{1}{4}$  in. and 12 in. long. One of the large plates is riveted to the channels at each end of the center sill, just inside of the end sill. One of the tie plates is





located at the center of the car, and the other two just over the vertical angle iron web stiffeners. The needle beams are located 4 ft. 1 in. each side of the center of the car, being supported at the center sill in pressed steel pockets and at the side sills by the truss rods. These truss rods extend the full length of the car, passing up over chairs located on top of the bolsters and extending through the end sills, where they are bolted to the steel end

frames are well proportioned. The corner posts are 6½ in. wide by 5¼ in. deep and are cut away in one corner, as shown, for the sheathing which is bolted to them. They are provided with a cap and shoe of malleable iron and are reinforced by 4 in., 8.2 lb. Z-bars which are set into the corner posts as shown, flush with the outside end face of the corner posts. These Z-bars are attached to the corner posts by ½ in. bolts, extending through

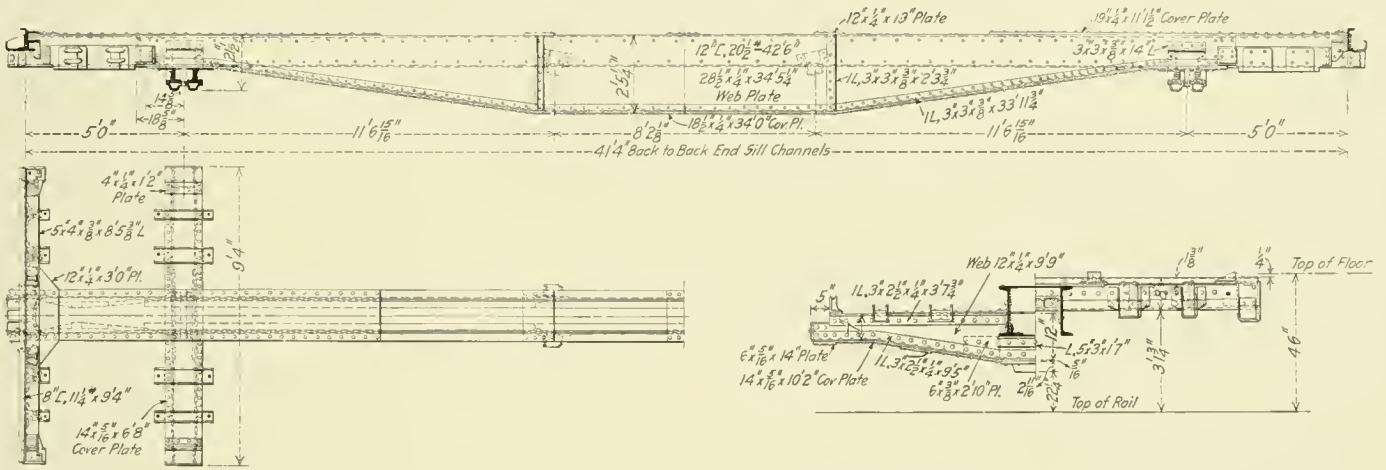

Steel Underframe for the Northern Pacific Stock Car

sill construction. The salient feature of this underframe is ample strength and the ease with which it may be repaired. Being made up of standard structural shapes it may be easily repaired at any shop along the line.

The side sills are 5 in. wide by 9 in. deep and extend the

full length of the car, resting on shoulders made in the bolster, as shown in the drawings, and supported in pressed steel pockets securely riveted to the end sills. There are four intermediate longitudinal sills. Those nearest the center sills are 5 in. by 8 in. and the other two 3 in. by 8 in. These sills extend the full length of the car.

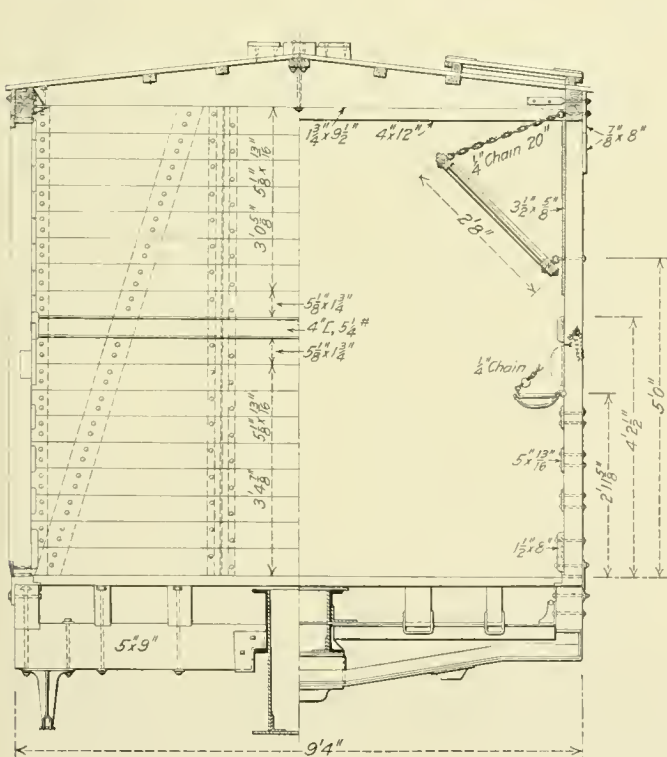

End Elevation and Cross Sections

full length of the car, resting on shoulders made in the bolster, as shown in the drawings, and supported in pressed steel pockets securely riveted to the end sills. There are four intermediate longitudinal sills. Those nearest the center sills are 5 in. by 8 in. and the other two 3 in. by 8 in. These sills extend the full length of the car.

The superstructure has a heavy end construction and the side

the steel Z-bars of the corner posts. The end framing is further reinforced by two 4 in. by 5½ in. diagonal braces.

The end belt rail is a 4 in., 5.25 lb. channel, which extends between the corner posts with its web flush with the outside of the end sheathing. As shown in Section XX, the flanges at each end of the channel are cut away and the web bent at an angle of 90 deg. for about 7 in., extending along the side belt rail and

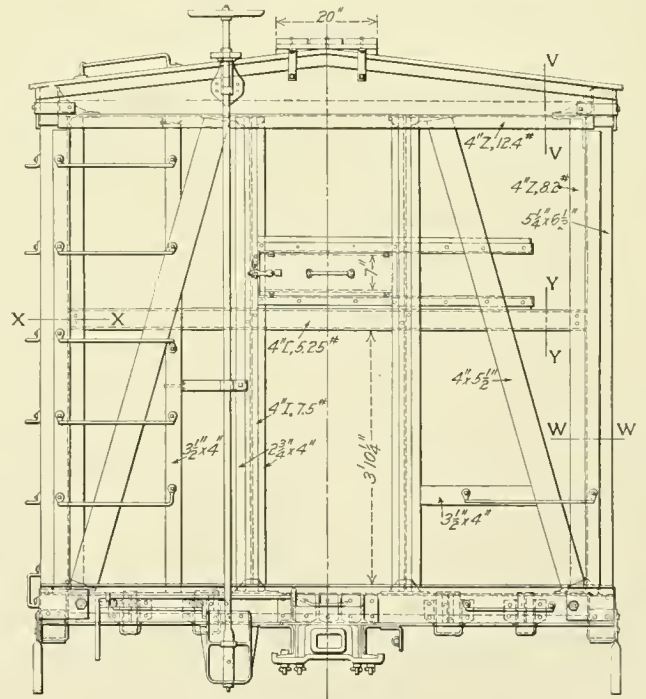



bolted to it. In addition to this there is a reinforcing plate 4 in. wide by 1/4 in. thick and 7 ft. 1 in. long which extends along the side belt rail and is bolted to the overlapping portion of the end belt rail. The end plate is 4 in. thick and 12 in. high at the center. It is reinforced by a 4 in., 12.4 lb. Z-bar which extends from corner post to corner post. It is further reinforced by a 3/8 in. tie rod extending from side plate to side plate. The end door shown is to be used when the cars are used for hauling lumber.

The side of the car is built up of 12 vertical posts and 16 diag-

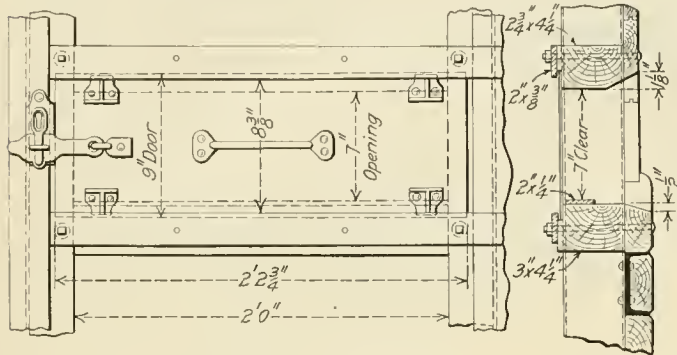

End Door Arrangement

onal posts, with the four door posts for the middle doors. Each of the vertical posts and the door posts are held to the side plate and side sill by 3/4 in. tie rods. The side posts and diagonal braces are set in malleable iron pockets and caps in both the side sill and the side plates. Sheathing 13/16 in. thick is used for the lining at the ends of the car as well as for the slats. The upper sheathing on the side of the car is 13/16 in. thick, and 5 1/8 in. wide. The side belt rails are 5 in. by 1 1/4 in. The roof is provided with 13 carlines 1 3/4 in. thick, which are held to the side plate by 1/2 in.

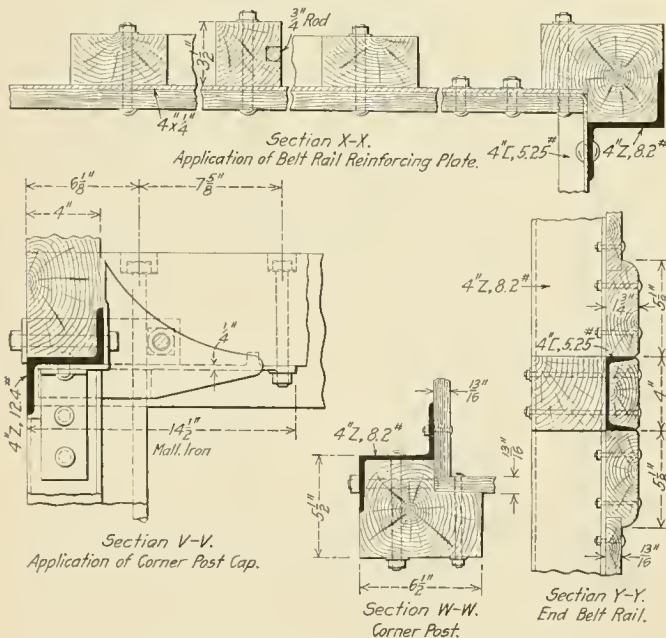

Northern Pacific Stock Car Framing Details

strap bolts. The purlins are 1 3/4 in. by 2 1/4 in. and the ridge pole 2 1/2 in. by 4 in.

The cars are provided with both water troughs and hay racks, the hay racks being loaded from six hatches in the roof on each side of the car. In applying these devices every means was taken to cover all the corners and sharp projections so that no injury could be done to stock. A hole is provided in the partitions between the sections of the water trough about an inch above the bottom of the trough, so that the amount of water in

the various compartments may be equalized when the car stands on track that is not on a level.

The special appliances employed are as follows: Camel Company doors, McCord journal boxes, Westinghouse air brakes, 675 lb. Griffin chilled iron wheels, Barber rolling truck device, H. W. Johns-Manville sill covering, Camel Company door fixtures, Miner draft gear, Sharon couplers and National end door locks. The side frames and truck bolsters are the design of the Northern Pacific Company and are bought as steel castings. The cars were built by the Whipple Car Company, Chicago.

The following are the general data:

Capacity .....	80,000 lb.
Light weight .....	39,500 lb.
Length, back to back of end sill channels.....	41 ft. 4 in.
Height of eaves from top of rail.....	11 ft. 9 1/4 in.
Width over side sills.....	9 ft. 4 in.

### HEATER CARS

While the demand for heater cars is not nearly as great as for cars under ice, it is often necessary to provide some means of protecting perishable freight from the cold. Some roads heat the cars at the loading points, relying on the insulation to hold the heat until the car reaches its destination. This system is quite satisfactory in moderate temperatures, but under more severe conditions it is necessary to place some portable heater in the car and carry it to the destination. At a slight additional expense it would be possible to construct refrigerator cars with a scientific system of heating, and as this class of traffic grows such systems probably will be more common. Refrigerator cars having the overhead icing system are also provided with a heater system. The inside sheathing of this design of car is wholly surrounded by an air space through which the cold air in summer, and the hot air, when the heater is used, circulate. In addition, provision is made for direct circulation in the inside of the car.

Other designs are also used for combination refrigerator and heater cars. This is a system that may be readily applied to any existing refrigerator cars by the simple addition of a series of four ducts in the floor, extending from the heater units in the middle of the car to the end bunkers. Two of the ducts deliver the heated air to the bunkers about half way up the end of the car; the other two are the return ducts, and extend but a short distance up from the floor on the end walls. The heat from the delivering ducts will rise to the top of the bunker and pass over the top of the bulkhead, and as it becomes cooled, it will return through the bottom of the bulkhead, returning to the heater through the return ducts.—*Railway Age Gazette.*

### CAR LIGHTING

The illumination of passenger cars can be greatly assisted by suitably curving the headlining, finishing it in white or other good reflecting color, and appropriately locating the source of light. Many forms of globes, shades and reflectors have been developed for car lighting, and the end is not yet in sight. On roads where electricity is the motive power, it is, of course, a simple matter to provide ample light, but where cars must be illuminated by a supply of gas or electric power carried on the car, the question of its economical use must be considered. Aside from the cost of fixtures, the most pleasing illumination is secured by the use of comparatively small units of light, evenly spaced along the center of a ceiling having an outline specially formed and colored to reflect and diffuse the light. Indirect lighting systems have been tried for car illumination, but are essentially uneconomical. Semi-indirect lighting systems give good results, however, and, when combined with a suitable outline and color of ceiling, are effective, extremely agreeable to the eye, and give absolutely shadowless illumination. Fixtures of this type are suitable for use either with gas or electric light.—*F. M. Brinckerhoff before the New England Railroad Club.*

### NEW HAVEN STEEL COACH

Announcement was made by the New York, New Haven & Hartford during the fall of 1913 that an order had been placed for 150 all-steel day coaches. The New Haven now has a

consist of pressed channel sections of 5/16 in. plate with a 3 in. flange and are reinforced by 6 in. by 3/8 in. top and bottom cover plates extending the full width of the car. The truck covers are placed 54 ft. 3 1/2 in. apart and the body bolsters are built up of 5/16 in. channels with a top cover plate 48 in. by 1/4 in.,

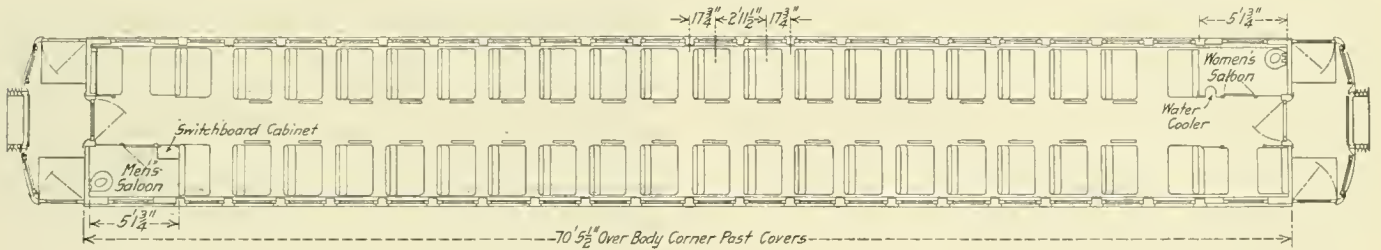

Floor Plan of 70 Ft. Steel Coach on the New Haven

large number of these cars in regular service, the first having been placed on the road early in November last.

These cars are 70 ft. 3 1/2 in. long over the end sills, have a seating capacity for 88 passengers and weigh 131,000 lb. The weight of the car body is 89,000 lb., and that of the two trucks

and two bottom cover plates 7 in. by 1/2 in., all three extending the full width of the car. There are 18 cross ties extending between the center sill and the side sill and supporting an intermediate floor stringer on either side of the car. These cross ties are of channel section pressed from 1/4 in. plate and are 5 in.

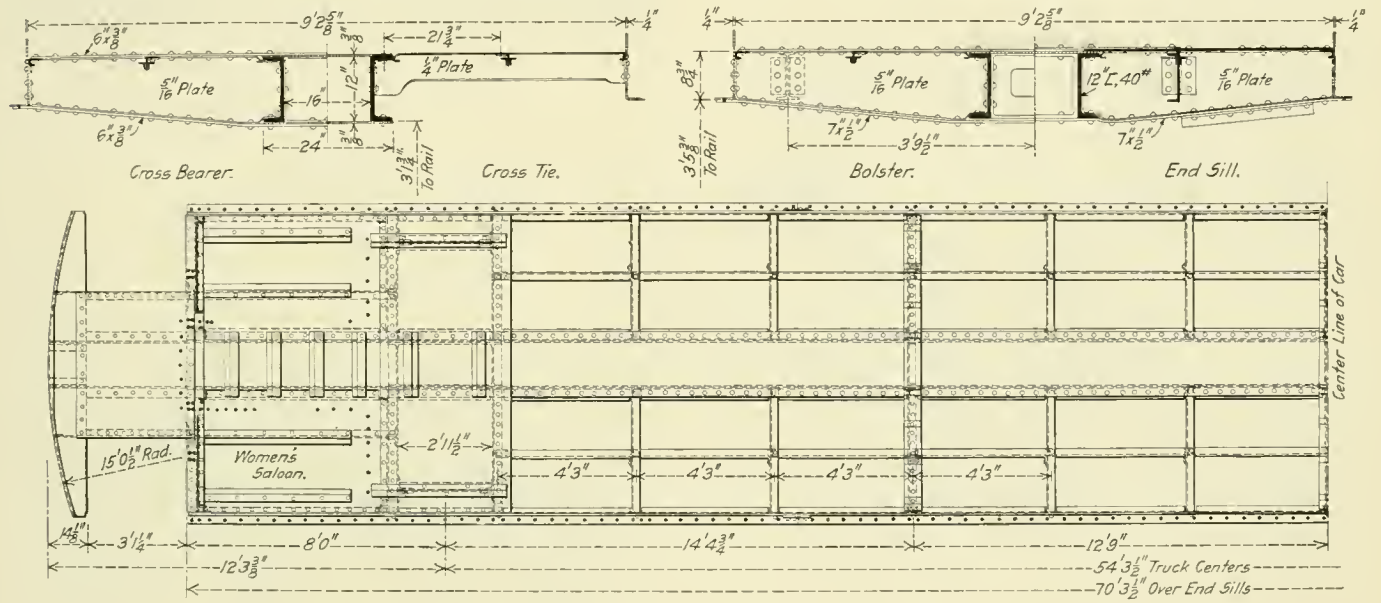

Arrangement of the Underframe of the New Haven Steel Car

42,000 lb. The center sills extend throughout the length of the car and consist of 12 in., 40 lb. channels with top and bottom cover plates 24 in. by 3/8 in. There are two cross bearers placed 12 ft. 9 in. on either side of the center line of the car. These

deep with a 3 in. flange. The side sills are 3 1/2 in. by 3 in. by 1/4 in. angles and extend the length of the car. The end sill is a 5/16 in. pressed channel with a 7 in. by 1/2 in. bottom cover plate extending across the car. A 9 in., 13.25 lb. channel, 2 ft. 2 3/4 in.



New York, New Haven and Hartford Steel Day Coach



on either side of the longitudinal center line of the car extends from the platform end sill to the body bolster.

Keystone flooring is used with a floor composition above and a layer of  $\frac{3}{4}$  in. hair felt below. The inside finish consists of  $\frac{1}{4}$  in. Agasote below the windows and  $\frac{3}{16}$  in. Agasote above. The  $\frac{3}{16}$  in. Agasote is also used in both the upper and lower decks. The interior of the car is finished in grained mahogany with the ceiling or deck in green with gold ornamentation.

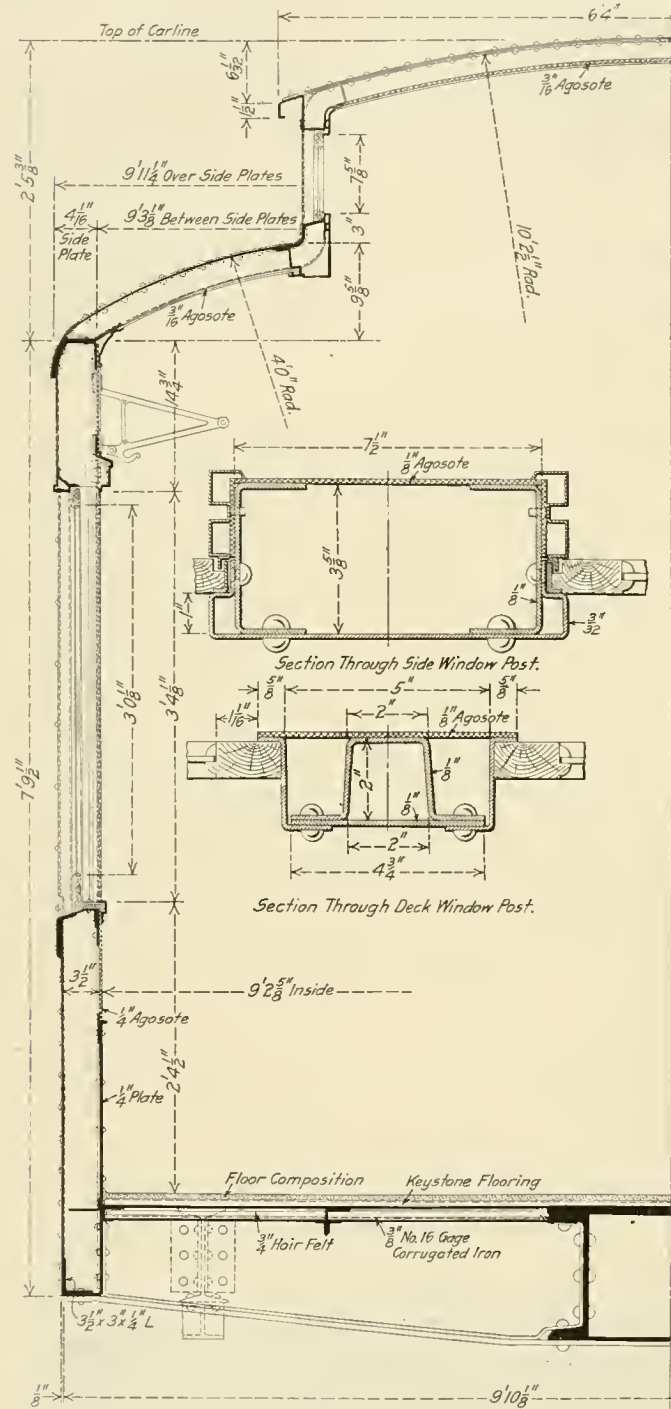

Sections Through the New Haven Coach

Mahogany is employed for the window sash. The interior hardware is finished in statuary bronze.

Among the specialties used in the car are the Miner buffing device and draft gear, Edwards trap doors, Ajax diaphragms and curtains, Buhoup three-stem couplers, Westinghouse schedule PC brakes, National sash locks, Automatic ventilators, Standard Heat & Ventilation Company's Ideal heating system,

Hale & Kilburn doors, Heywood Brothers & Wakefield seats and McCarthy continuous basket racks. The insulation is three-ply Salamander.

The cars are electrically lighted, the axle generator system



Interior of the New Haven Steel Coach

being used. There are six one-light center lamps and 24 one-light bracket lamps on the deck rail staggered over alternate seats with two one-light pendants in each vestibule.

The following are the principal dimensions and data:

Length over end sills.....	70 ft. 3 1/2 in.
Length over buffer face plates.....	80 ft. 3 3/4 in.
Length inside .....	69 ft. 7 1/4 in.

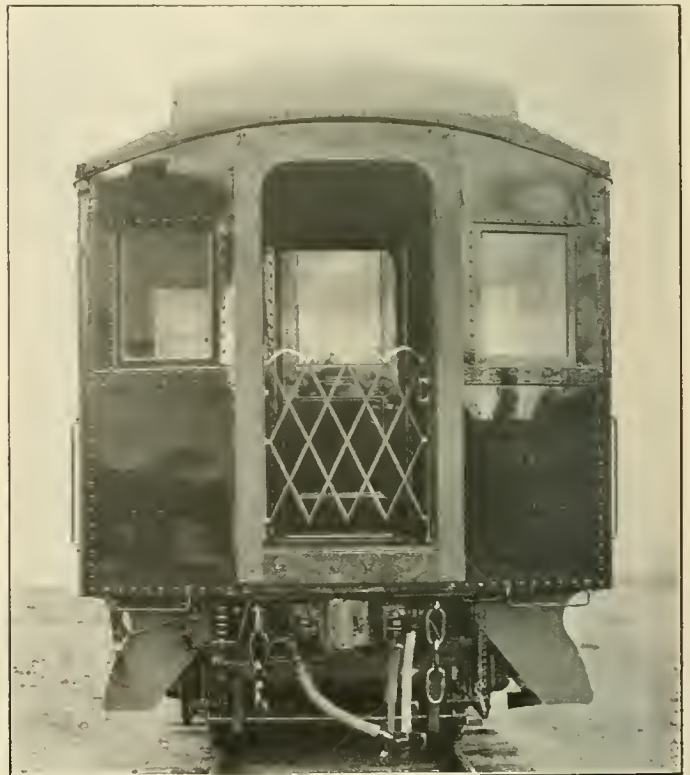

End View of the New Haven Steel Coach

Width over side plates.....	9 ft. 11 1/4 in.
Width over lower deck eaves.....	10 ft. 0 in.
Width over upper deck eaves.....	6 ft. 4 in.
Width over platform steps.....	9 ft. 1 in.
Height, rail to lower deck eaves.....	10 ft. 11 1/2 in.

Height, rail to upper deck eaves.....	13 ft. 2 3/4 in.
Height, rail to top of roof.....	13 ft. 8 1/4 in.
Height, rail to top of platform.....	4 ft. 2 in.
Height, rail to top of body floor.....	4 ft. 3 1/2 in.
Truck wheel base.....	10 ft. 6 in.
Distance center to center of trucks.....	54 ft. 3 1/2 in.
Seating capacity.....	88
Total wheel base.....	64 ft. 9 1/2 in.

### BRAKE EFFICIENCY TESTS ON STEEL AND IRON WHEELS\*

BY F. K. VIAL

Chief Engineer, Griffin Wheel Company, Chicago, Ill.

The coefficient of friction between the brake shoe and the moving wheel, which is the measure of brake efficiency, is a variable quantity depending on the speed and kind of wheel, the shoe pressure, the length of time the shoe is applied; the kind of shoe, whether plain, chilled or with inserts; the kind and shape of the inserts; the condition of the shoe, etc. The coefficients of friction for a large variety of brake shoes under varying conditions have been determined at Purdue University in a series of tests conducted for the M. C. B. Association and reported in the M. C. B. Proceedings for the year 1910-1911. Supplementary tests were also made for the Association of Manufacturers of Chilled Car Wheels.

For the original test, 14 pairs of brake shoes were selected, as indicated in Table I. One set of 14 shoes was tested at the

TABLE 2.—PURDUE TESTS FOR M. C. B. ASSOCIATION\*

Kind of Shoe	Coefficients of friction with a steel tired wheel—Initial speed 80 m. p. h.				
	Shoe pressures in pounds				
	12,000	14,000	16,000	18,000	20,000
Congdon.....	9.60	9.08	8.68	8.57	7.25
Plain cast iron.....	8.22	9.22	9.19	8.70	7.21
Spear-Miller.....	9.98	9.47	8.42	7.67	8.30
National.....	8.73	8.99	8.67	7.68	6.87
Diamond S.....	9.72	9.55	8.73	8.86	7.02
U shoe.....	9.60	9.27	8.72	8.45	7.34
Pittsburgh.....	19.75	18.75	17.75	17.10	15.27

\*Proceedings M. C. B. Association 1911.

A series of tests were also conducted for the Association of Manufacturers of Chilled Car Wheels at Purdue University, with brake shoes acting on both the chilled iron and steel wheel tested under pressures of 2,808, 4,152, 6,840 and 12,000 lb., from an initial speed of 40 m. p. h. The results of these tests are given in Table 3.

TABLE 3.—PURDUE TESTS FOR ASSOCIATION OF MANUFACTURERS OF CHILLED CAR WHEELS

Kind of Brake Shoe	Coefficients of friction from initial speed of 40 m. p. h.			
	Chilled iron Pressures		Rolled steel wheels Pressures	
	2,808	4,152	6,840	12,000
Streeter.....	24.7	20.8	17.6	13.8
Lappin chill. ends.....	18.5	16.5	14.8	13.6
Diamond S.....	22.5	20.0	18.4	14.8
V inserts, chilled				
inserts.....	17.4	17.0	11.8	10.9
Average.....	20.8	18.6	15.6	13.3
	19.8	17.1	13.9	12.2

A review of the foregoing tests will show that a greater coefficient of friction is obtained with the chilled iron wheel. The number of brake shoes used in the various tests are dif-

TABLE I.—BRAKE SHOE FRICTION TESTS\*

Test laboratory	Type of Brake Shoe	‡Chilled iron wheel. Shoe pressure in pounds	Mean coefficient of friction in per cent.—Initial speed of 65 m. p. h. steel tired wheel. Shoe pressure in pounds								
			2,808	4,152	6,840	10,000	12,000	15,000	18,000		
A. B. S. & F. Co....	Plain cast iron—(C. & N. W.).....	26.3	21.7	21.0	16.3	13.1	11.0	.....	.....	.....	.....
Purdue.....	Plain cast iron—(C. & N. W.).....	22.1	21.6	20.4	16.0	.....	12.4	.....	10.4	.....	.....
A. B. S. & F. Co....	Plain cast iron—(without re-inf.).....	25.1	23.5	20.6	.....	.....	11.7	.....	.....	.....	.....
Purdue.....	Plain cast iron—(without re-inf.).....	30.3	27.7	24.5	16.3	.....	13.5	.....	11.6	.....	.....
A. B. S. & F. Co....	Congdon—7 wrought ins'ts (C. & N. W.).....	26.8	19.0	15.3	19.7	17.7	12.4	8.9	9.4	8.2	7.7
Purdue.....	Congdon—7 wrought ins'ts (C. & N. W.).....	22.2	19.8	16.4	20.6	.....	14.0	.....	11.3	.....	.....
A. B. S. & F. Co....	Congdon—5 wrought ins'ts (A. B. S. & F.).....	25.0	18.3	17.2	20.3	18.0	11.8	9.5	9.8	8.5	7.6
Purdue.....	Congdon—5 wrought ins'ts (A. B. S. & F.).....	24.4	22.6	19.1	15.1	.....	11.9	.....	11.7	.....	.....
A. B. S. & F. Co....	Streeter—2 hard iron ins'ts (A. B. S. & F.).....	24.5	22.6	19.0	16.9	14.9	11.2	11.7	10.4	9.5	9.1
Purdue.....	Streeter—2 hard iron ins'ts (A. B. S. & F.).....	21.3	20.6	16.4	13.6	.....	10.8	.....	10.7	.....	.....
A. B. S. & F. Co....	Lappin—chilled ends (A. B. S. & F.).....	18.2	16.8	16.1	15.0	13.4	10.1	8.8	8.6	8.8	6.8
Purdue.....	Lappin—chilled ends (A. B. S. & F.).....	20.5	19.6	18.9	17.0	.....	13.0	.....	11.1	.....	.....
A. B. S. & F. Co....	Lappin—chilled ends (A. B. S. & F.).....	20.5	18.4	14.3	16.3	15.1	11.6	9.1	9.3	7.9	6.6
Purdue.....	Lappin—chilled ends (A. B. S. & F.).....	18.4	17.8	17.5	16.9	.....	12.7	.....	12.2	.....	.....
A. B. S. & F. Co....	Plain cast iron (A. B. S. & F.).....	27.0	25.1	21.9	16.8	13.5	11.3	9.7	8.4	9.3	8.5
Purdue.....	Plain cast iron (A. B. S. & F.).....	21.0	20.3	18.5	16.2	.....	13.2	.....	11.1	.....	.....
A. B. S. & F. Co....	Plain cast iron (Columbia B. S. Co.).....	27.0	28.6	21.8	18.3	14.0	13.5	15.3	.....	.....	.....
Purdue.....	Plain cast iron (Columbia B. S. Co.).....	21.0	18.9	17.3	16.8	.....	13.1	.....	10.7	.....	.....
A. B. S. & F. Co....	Diamond S—chilled ends (A. B. S. & F.).....	24.2	20.0	16.2	21.5	17.4	13.5	11.2	10.8	9.8	9.8
Purdue.....	Diamond S—chilled ends (A. B. S. & F.).....	22.8	20.5	18.3	17.3	.....	13.6	.....	12.3	.....	.....
A. B. S. & F. Co....	Walsh—2 hard iron ins'ts (W. B. S. Co.).....	22.6	20.0	14.9	14.7	12.1	10.3	8.7	8.6	9.1	8.7
Purdue.....	Walsh—2 hard iron ins'ts (W. B. S. Co.).....	23.7	20.5	19.8	16.6	.....	14.4	.....	11.5	.....	.....
A. B. S. & F. Co....	Pittsburgh malleable iron shell.....	24.4	21.9	17.0	17.7	17.9	17.5	14.0	11.8	11.2	10.7
Purdue.....	Pittsburgh malleable iron shell.....	26.8	25.4	21.5	22.8	.....	18.9	.....	17.6	.....	.....
A. B. S. & F. Co....	Pittsburgh steel shell (P. B. S. Co.).....	29.9	29.6	24.2	23.0	20.9	18.7	15.8	14.7	14.2	15.3
Purdue.....	Pittsburgh steel shell (P. B. S. Co.).....	29.4	27.5	23.4	25.8	.....	23.2	.....	22.2	.....	.....
A. B. S. & F. Co....	National—chilled ends (N. B. S. Co.).....	16.3	15.2	11.9	15.1	11.3	9.8	8.2	7.5	6.9	8.3
Purdue.....	National—chilled ends (N. B. S. Co.).....	19.3	16.4	14.3	15.2	.....	12.1	.....	11.2	.....	.....

\*Taken from the 1910 M. C. B. Proceedings. †Mean coefficient of friction in per cent.—Initial speed of 40 m. p. h.

laboratory of Purdue University, and the other set was tested on the brake shoe testing machine of the American Brake Shoe & Foundry Company at Mahwah, N. J. The coefficients of friction were determined on a chilled iron wheel in effecting stops from an initial speed of 40 m. p. h. under three brake shoe pressures, viz., 2,808, 4,152 and 6,840 lb. On the steel wheel the coefficients of friction were determined at pressures of 2,808, 4,152, 6,840, 10,000, 12,000, 15,000 and 18,000 lb., effecting stops from an initial speed of 65 m. p. h. The results are shown in Table I.

The tests made at Purdue University, and reported in the M. C. B. Proceedings of 1911, were conducted on seven shoes effecting stops from 80 m. p. h. at pressures of 12,000, 14,000, 16,000, 18,000 and 20,000 lb., as shown in Table 2.

\*This review was prepared for the Association of Manufacturers of Chilled Car Wheels, the data being obtained from a series of tests made for them at Purdue University during 1913.

ferent, therefore the averages are not exactly on the same basis. The results from the Diamond S shoe throughout seem to be very consistent. The tests made by Purdue University in 1910 show the Diamond S coefficients at the different pressures to be almost exactly equal to the average of all the shoes tested. Again in 1913, the shoes tested for the Association of Manufacturers of Chilled Car Wheels give the identical coefficients for the Diamond S shoe, and for that reason we know that the tests are comparative, although they were not all made at the same time. The results with this type of brake shoe are shown in Fig. 1. From this diagram, and from the review of the tables in general, the indications are very evident that there is a dropping off in the coefficient of friction in brake shoes, as the pressure increases. The rate of decrease amounts to about 6 per cent of the coefficient of friction for each increase of 1,000 lb. pressure. This 6 per cent drop is constant within the limits of these tests and holds



true for both the chilled iron and steel wheels. This may be illustrated by the following data from the tests conducted by Purdue University for the Association of Manufacturers of Chilled Car Wheels:

Pressure-pounds	Chilled iron wheels		Steel wheels	
	Efficiency	Calculated Efficiency	Efficiency	Calculated Efficiency
3,000	22.	....	19.3	....
4,000	20.7	20.7	17.1	18.1
5,000	19.4	19.5	15.6	16.
6,000	18.4	18.3	14.5	14.6
7,000	17.6	17.3	13.7	13.6
8,000	16.9	16.6	13.1	12.8
9,000	16.3	15.9	12.6	12.3
10,000	15.8	15.4	12.2	11.8
11,000	15.3	14.9	11.9	11.4
12,000	14.8	14.4	11.7	11.1

While there are some departures from this 6 per cent reduction per 1,000 lb. addition to shoe pressure, these variations are compensating. In general the calculated values follow the observed values very closely.

It is also evident that there is a dropping off in the coefficient of friction as the velocity of the rotating wheel increases. It is, therefore, self evident that the retarding force is not proportional to the braking power or shoe pressure, but in general terms, for pressures between 2,000 and 15,000 lb. per shoe, the amount of work accomplished increases with but half the rapidity that the shoe pressure increases, that is to say, doubling the shoe pressure will increase the retarding effect 50 per cent. This is shown graphically in Fig. 2. At very low and very high pressures the work accomplished in-

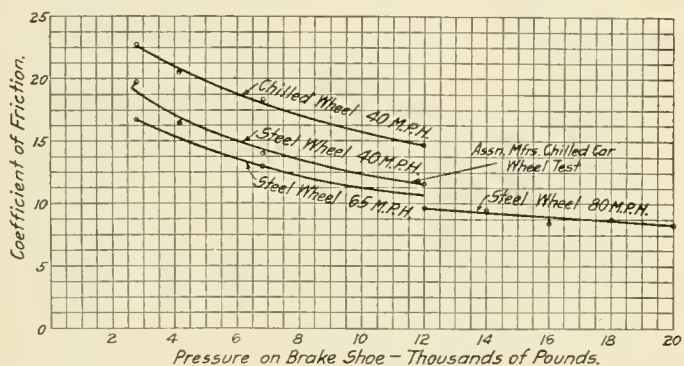

Fig. 1—Coefficient of Friction for Diamond S Brake Shoe in Stops from Various Initial Speeds

creases in a very much lower ratio. In the case of the Diamond S shoe on the chilled iron wheel, at a constant speed of 20 m. p. h., the coefficient of friction at 800 lb. pressure was 44 per cent, and at 2,000 lb. pressure, 26.3 per cent. This is shown graphically in Fig. 3. The retarding force at 800 lb. was 352 lb., while at 2,000 lb. pressure, the retarding force was 526 lb. This shows that for an increase in shoe pressure of 150 per cent, the work done increased but 50 per cent. This shows the great advantage of the small continuous pressure as compared with heavy intermittent pressure in controlling trains on heavy grades.

At very high pressures, Dean Benjamin of Purdue University states, in his report of May 10, 1911, to the chairman of the Brake Shoe Committee of the M. C. B. Association: "It is easily seen that the coefficients of friction drop rapidly between 18,000 and 20,000 lb. pressure, and that the amount of wear is correspondingly great while the stopping distance, of course, is not materially diminished."

RELATION OF SPEED TO COEFFICIENT OF FRICTION

On account of the majority of tests on the steel wheel having been made at high speeds and those on the chilled iron wheel at 40 m. p. h. and less, a direct comparison of the effect of speed on the coefficient of friction is not as clearly worked out as would be desirable. However, there is sufficient data to indicate the probable effect through a range of from 40 to

80 m. p. h. This is brought out in Fig. 1. Under heavier pressures the effect of speed is not as noticeable as at lower pressures. The probability is that after reaching 12,000 lb. pressure the speed effect is very largely eliminated, whereas at the lower pressures the effect of increasing speeds is a very material reduction in the coefficient of friction. There are two tests on steel wheels that may be compared. One of these was made with an initial speed of 40 m. p. h., the second

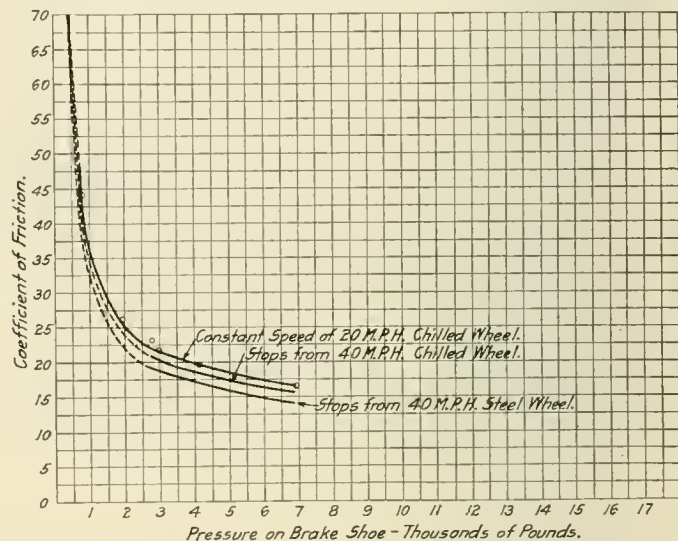

Fig. 2—Comparison of Coefficient of Friction in Stops from Initial Speed of 40 Miles per Hour and Uniform Speed of 20 Miles per Hour

with an initial speed of 65 m. p. h. From these tests it has been found that there is a drop of 10 per cent in brake efficiency in passing from 40 to 65 m. p. h. with steel wheels. There is no data at hand to show just what the variation is in the case of chilled wheels, but it is very probable that the loss in efficiency at higher speeds is very similar to that of steel wheels under like conditions.

BRAKE EFFICIENCY—CHILLED IRON VS. STEEL WHEELS

The question is often raised as to whether the brake efficiency of chilled iron wheels is equal to that of steel wheels.

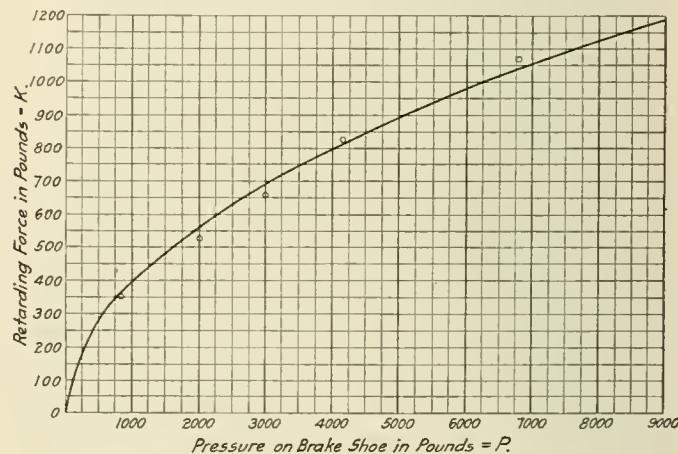

Fig. 3—Relation of Retarding Force to Pressure on Brake Shoe at 20 Miles per Hour

The indication is very strong in all the foregoing tests that not only is the brake efficiency of the chilled iron wheel equal to that of the steel wheel, but as a matter of fact, it is about 25 per cent higher. This is shown in comparing the tests made for the Association of Manufacturers of Chilled Car Wheels with the tests made for the M. C. B. Association,

stops being made from an initial speed of 40 m. p. h. According to Fig. 1 the coefficients of friction are easily 25 per cent in favor of the chilled iron wheel in stops made from an initial speed of 40 m. p. h. That the coefficient of friction between the brake shoe and the chilled iron wheel is materially greater than on the steel wheel, all conditions being equal, is clearly indicated in the M. C. B. Association specifications which state as follows:

	Coeff. of Friction Per cent.
First: Tests upon chilled iron wheel from an initial speed of 40 m. p. h.—	
at 2,808 lb. pressure.....	22
at 4,152 lb. pressure.....	20
at 6,840 lb. pressure.....	16
Second: Tests upon steel wheel from an initial speed of 65 m. p. h.—	
at 2,808 lb. pressure.....	16
at 4,152 lb. pressure.....	14
at 6,840 lb. pressure.....	12

Although the specifications required that the speed of the steel wheel be 65 m. p. h., and the chilled iron wheel 40 m. p. h., it does not seem that the difference on account of the speed element can amount to more than 10 per cent. Therefore, reducing the specifications for coefficients of friction on the steel wheel to 40 m. p. h. by the use of this factor, we have the following comparison of coefficients of friction on brake shoes for stops from an initial speed of 40 m. p. h. on both the chilled iron and steel wheel:

Pressure lb.	COEFFICIENT OF FRICTION			Per cent. in favor of chilled iron
	Chilled iron Per cent.	Steel wheel Per cent.	Difference	
2,808 .....	22	17.6	4.4	25.
4,152 .....	20	15.4	4.6	29.8
6,840 .....	16	13.2	2.8	21.2

This indicates that the M. C. B. Association, in their specifications, demand 25 per cent greater efficiency in brake shoes when applied to chilled iron wheels than when applied to steel wheels. Applying these specifications to the tests made at Purdue University for the Association of Manufacturers of Chilled Car Wheels, we note that only two of the shoes fully met the specifications. These were the Streeter and Diamond S, which showed the following percentages in favor of the chilled iron wheel:

Streeter shoe:  
 At 2,808 lb. pres. retard. force 15.4 per cent. greater in chilled iron wheel  
 At 4,152 lb. pres. retard. force 11.2 per cent. greater in chilled iron wheel  
 At 6,840 lb. pres. retard. force 19.7 per cent. greater in chilled iron wheel  
 At 12,000 lb. pres. retard. force 7.8 per cent. greater in chilled iron wheel

Diamond S shoe:  
 At 2,808 lb. pres. retard. force 13.6 per cent. greater in chilled iron wheel  
 At 4,152 lb. pres. retard. force 11.2 per cent. greater in chilled iron wheel  
 At 6,840 lb. pres. retard. force 31.4 per cent. greater in chilled iron wheel  
 At 12,000 lb. pres. retard. force 26.5 per cent. greater in chilled iron wheel

In the report of Purdue University, signed by Lewis E. Endsley, addressed to the chairman of the M. C. B. Committee on Brake Shoe Tests, dated February 21, 1910, is found the following note concerning the tests:

"None of the 14 shoes tested damaged the surface of the cast iron wheel during the wearing test. In the wearing test on the steel tired wheel at a constant speed of 30 m. p. h. and at a pressure of 2,808 lb., two shoes scored the wheel.

"Shoe No. 286, which was given 300 applications, cut four V shaped grooves about 1/32 in. deep and several smaller ones in the surface of the wheel around the entire circumference. After test of this shoe, the wheel had to be ground with a revolving emery wheel in order to get a smooth surface for the next shoe.

"The other shoe that scored the steel tired wheel was No. 288. This shoe was given only 100 applications for in that time it had cut five grooves similar to those cut by shoe No. 286."

The foregoing shows that insert shoes cannot be used on steel wheels on account of the severe scoring and wearing away of the steel, whereas no such effect is found on the chilled iron wheel; and it will be found that the shoes with the steel inserts, which do the most damage to the steel wheels and, therefore, cannot be used, are the ones which give the high coefficient of friction and should be eliminated from consideration in making comparisons of laboratory

tests. The final conclusion from all tests made at Purdue University is that the coefficient of brake shoe friction on chilled iron wheels is fully 25 per cent greater than on the steel wheels when working under ordinary conditions.

## CAST IRON CAR WHEEL DESIGN

The paper presented by Prof. Louis Endsley at the March meeting of the Western Railway Club, on tests made at Purdue University, on the M. C. B. brake shoe testing machine, to determine the stress in the plate of cast iron wheels due to the heat produced by the brake shoe, contains much interesting and original information. Nine different wheels were tested as follows: M. C. B. standard 625 lb. wheel, M. C. B. standard 675 lb. wheel, M. C. B. standard 725 lb. wheel, 640 lb. wheel having an arch plate, 690 lb. wheel having an arch plate, 740 lb. wheel having an arch plate, 690 lb. wheel having a specially designed plate (this wheel has the same dimensions as the M. C. B. 625 lb. wheel, with the exception that the metal had been added to the plate of the wheel to make it weigh 690 lb.), and a 690 lb. wheel having a specially designed rim (this wheel has the same dimensions as the 625 lb. M. C. B. wheel, with the exception that the metal was added to its rim to bring the weight up to 690 lb.).

The purpose of the test was to determine the stress in the plate of the wheel under different conditions of braking. The wheels were run at speeds of various magnitudes and the pressures of the shoe on the wheel were 800 lb., 2,808 lb., 4,152 lb. and 6,840 lb. The method of obtaining the stress in the plate was rather unique. Prof. Endsley used the Berry strain gage, which measures the elongation between two points two inches apart, with an accuracy within one ten-thousandth of an inch. It was believed that the plate would be under severe strain, due to the heat expanding the rim of the wheel. This was found to be the case.

A piece of car wheel iron was first tested on a tension testing machine to determine the amount of stress per unit of elongation. The results thus obtained were used to interpret the readings of the Berry strain gage. The necessary correction for the expansion of the metal at the point of reading was obtained by placing a thermometer at the point in the plate of the wheel where the reading was taken. This correction was deducted from the reading of the strain gage, the difference being the elongation due to the pulling of the rim of the wheel on the gage.

It was found that the stress in the plate for any given wheel is nearly proportional to the difference in temperature between the hub and rim. This held true whether the rim temperature was high or low, the difference in the temperature being the controlling factor. For any given test this difference in temperature becomes a constant, and after it has become constant the stresses also remain constant. It was found that the maximum stress of the plate in wheels working with a brake shoe at a continuous pressure was the same as when the intermittent pressure was applied, if the work in both cases amounted to the same ultimate total. The factor that affects this stress the most is the design of the wheel. The stress was found to vary from 12,000 lb. in the 840 lb. arch plate wheel to 20,000 lb. in the M. C. B. standard 675 lb. wheel. It was also found that the three arch plate wheels had a much lower stress than the standard M. C. B. wheels, which would indicate that the reverse curve in the plate of the standard M. C. B. wheels was of no real benefit and that a plate with a smooth curve of large radius would give much more satisfactory results.

GOLD IN RUSSIA.—According to official statistics, there were, in 1912, in the Orenburg mining district 303 gold-washing concerns, of which, however, only 58 were in operation.—*Engineering*.



## STEEL ENDS FOR BOX CARS\*

BY W. A. MCGEE

Chief Draftsman, Lake Shore & Michigan Southern, Cleveland, Ohio

As all car builders and designers know, two great points of weakness have developed in the construction of wooden box cars; the first is the underframe and the second is the end. While much has been done to overcome the weakness of the underframes by constructing them of steel, little has been done to overcome the weakness of the ends.

The accompanying illustration shows an end constructed of

Kind and construction of end	Safe load uniformly distributed over entire surface	Total weight	Increased strength of steel over wooden end	Uniform load in pounds per pound weight of end
Wood, with oak posts and malleable iron pockets.....	7,500 lb.	1,050 lb.	....	7.15
Steel, with 3/16 in. plate reinforced with nine 3 in., 4 lb. channels .....	13,000 lb.	1,300 lb.	73%	10
Steel, with 3/16 in. plate on top section and 1/4 in. plate on bottom section, reinforced with nine 3 in., 5.5 lb. I-beams...	20,000 lb.	1,630 lb.	166%	12.2
Steel, with 3/16 in. plate on top section and 1/4 in. plate on bottom section, reinforced with nine 4 in., 5.25 lb. channels.	23,000 lb.	1,730 lb.	206%	13.3
Steel, with 3/16 in. plate on top section and 1/4 in. plate on bottom section, reinforced with nine 4 in., 7.5 lb. I-beams...	32,000 lb.	1,800 lb.	326%	17.75

steel plate and standard rolled steel shapes, which to a great extent overcomes the weakness of the wooden end. It is com-

posed of steel plates  $P_1$  and  $P_2$ , reinforced with rolled steel beams or channels  $C$  to which wooden sleepers  $A$  are bolted for the

purpose of nailing on the inside sheathing. The reinforcing beams are held by means of angle clips  $D$ , which are bolted through the end plate and end sill of the car.

The use of this end increases the strength of the car and prevents bulging or breaking due to the shifting of the load. It requires no special dies or bending machines in manufacture, and quick repairs can be made on account of the parts being made of standard rolled material which can be readily obtained from stock. It can be made any desired strength, depending on conditions and the capacity of the car. For box cars of 40,000 lb. to 50,000 lb. capacity it should be made of 3/16 in. plate, reinforced with 3 in. channels or I beams; for box cars of 60,000 lb. capacity or over, of 3/16 in. plate on the top section and 1/4 in. plate on the bottom section, reinforced with 4 in. channels or I beams.

The accompanying table shows the comparative strength, weights, etc., of the steel and wooden ends.

**GOLD PLACERS IN ALASKA.**—Since mining began in Alaska in 1880 the gold placers of the territory have yielded 7,488,491 fine ounces of gold, valued at \$154,800,875.

**OHIO MINE RESCUE CAR.**—John C. Davis, chief inspector of mines for the state of Ohio, has designed a rescue car, the interior arrangement of which is somewhat different from other rescue cars. In planning this car the designer kept in mind that it was to be used in emergency cases, and eliminated those features which had no direct bearing upon its objective use. There is a living room for one man; no more toilets are to be installed than are absolutely necessary, thus saving room which will be used for the hospital, and other practical features. The

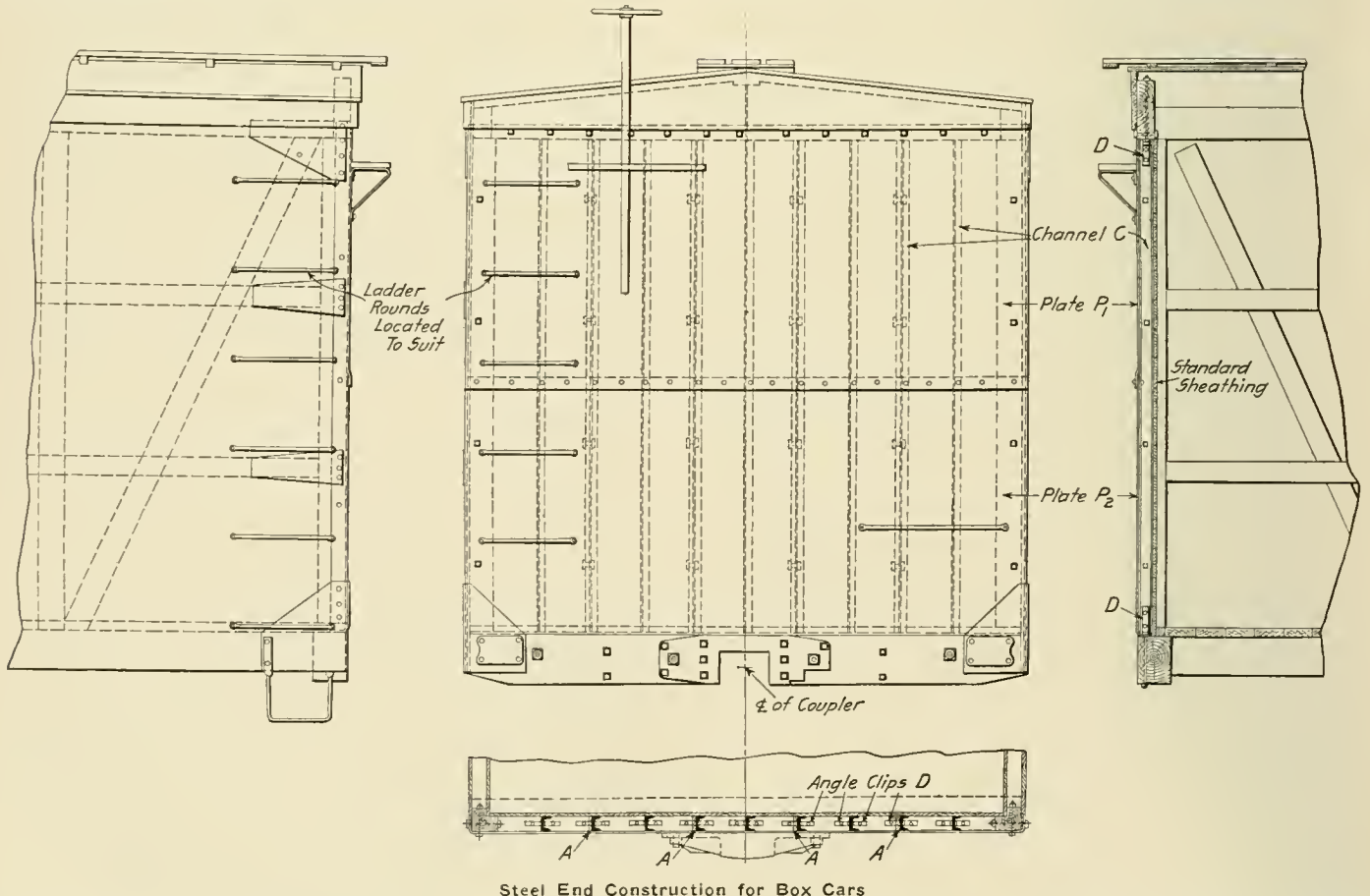

Steel End Construction for Box Cars

posed of steel plates  $P_1$  and  $P_2$ , reinforced with rolled steel beams or channels  $C$  to which wooden sleepers  $A$  are bolted for the

car is to be equipped with safety apparatus, hospital arrangement, and first-aid supplies, and it will be stationed at Columbus and kept in readiness to be sent to the place of disaster as soon as notice is received.—*The Colliery Engineer.*

\*Entered in the Car Department Competition which closed February 1, 1914.

# SHOP PRACTICE

## LOCOMOTIVE MILEAGE AND REPAIR RECORDS ON THE CANADIAN PACIFIC

In arriving at the amount of money which should be spent in repairing locomotives on the Canadian Pacific, a system has been adopted using a definite allowance per mile between shoppings. This allowance varies directly with the hauling power, and in the case of a 100 per cent engine (20,000 lb. tractive effort) is 2.5 cents per mile on the Eastern Lines. A slightly higher figure is used for the Western Lines owing to the higher rates of wages in force there.

This rate per mile is not by any means an arbitrary figure, but has been determined on after careful study of all the factors involved, and from a study of the costs shown by the records for a number of years previous to the adoption of this method.

Taking the case of a 100 per cent engine that has made 75,000 miles, there would be available \$1,875 for repairs. This has been determined, as indicated above, to be a fair average amount to be spent for repairs on that class of locomotive after a mileage of 75,000. If, because of some exceptional conditions under which the engine has been working, or some extraordinarily heavy repairs found necessary after the engine is in the shop, it becomes necessary to spend \$2,000, it is an indication that either the previous repairs were not thorough enough to permit of the engine making its mileage allowance or that the running repairs had been neglected in the roundhouse.

This is called to the attention of the master mechanic under whose supervision the engine was, and provides him with a means of locating weak spots in his organization.

After the general repairs (No. 1) the engine starts again with a clean record. If it is later found necessary to shop the engine for any cause, either light general repairs, classified as No. 2, or specific repairs, classified as No. 3, the amount available would, of course, be the mileage made to date multiplied by the rate. When the engine has later made the full mileage and is shopped again for general overhauling, the amount spent on the intermediate repairs is deducted from the total which would otherwise be available.

For example, considering the same engine as previously, if the mileage up to the time of the intermediate repairs was 30,000, the amount available would be \$750. It might, however, be necessary to spend \$1,000, in which case the total amount spent on the intermediate repairs would be held as a charge against the engine at the time of the next general overhauling, thus cutting down the amount available.

For example, if the engine made 45,000 miles after the intermediate repairs, the amount available would be  $75,000 \times 2.5 = \$1,875 - \$1,000 = \$875$ . It would, of course, hardly be possible to give the engine a general overhauling for this amount, and the overdraw in this case would show against the division master mechanic's record.

To prevent this, the master mechanic would, after the intermediate repairs, endeavor to run the engine as long as possible in order to get as much more mileage as possible, so that when next stopped for overhauling as large an amount as could be obtained would be credited to the engine.

The object of keeping a separate account of each engine in this way is to distinguish between those engines which cost more and those which cost less than the average, and thus enable the division master mechanic to keep in close touch with what each engine is doing, and to check up the roundhouse foreman who is neglecting the maintenance of his engines. The charges are used

entirely for this purpose, as each engine is, of course, thoroughly repaired regardless of the mileage charges against it. It will readily be seen, however, that the system forms an excellent means of keeping track of the records of both locomotives and mechanical department officers.

The mileage allowance between shoppings is based on peculiarities of the particular type and design of locomotive, and on the modern power varies from 75,000 to 125,000.

## FIREBOX RIVETING

BY N. H. AHSIUOLH

The fitting and riveting of tube sheets and side sheets in wide fireboxes, as locomotives go through the shops for repairs, are among the heaviest jobs encountered by boilermakers. Various methods of fitting the sheets and driving the rivets are employed, but those described in this article have been successfully used by the author for the past ten years.

The tube sheets are laid out and punched, and the flanges are scarfed from the center of the rivet holes to one-half the original

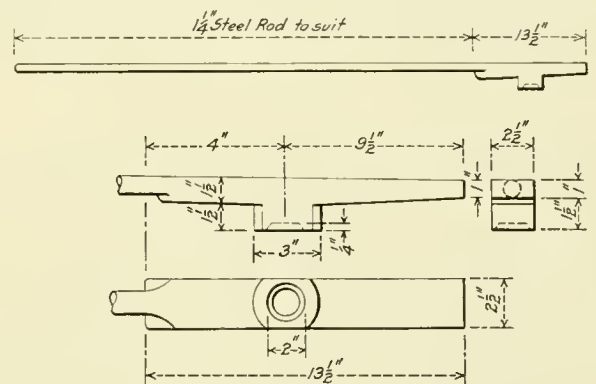

Fig. 1

thickness at the edge of the lap. A 1 1/16 in. lap is allowed from the center line of the rivet holes for 3/4 in. rivets. The flange holes are then countersunk and the sheet is bolted in place in the firebox, using temporary bolts in every third hole all around the flange. The crown sheet is heated and laid in place on the flue sheet flange; the top corners, the side flanges and the mudring corners are then heated and fitted up tight. A 9 in. stroke

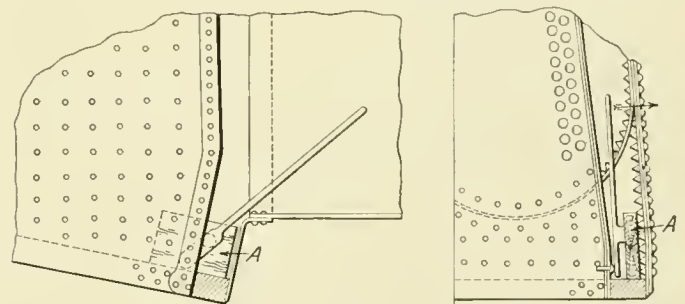

Fig. 2

riveting hammer and a flat die are used to drive the rivets, while a small air hammer and bob tool are used to finish and caulk them. One boilermaker, one helper and a rivet boy generally drive all the rivets in the tube sheet flanges, in from six to eight hours.

Fig. 1 illustrates the type of holding on bar used on the water



leg rivets on the sides of the tube sheet. The heel of this bar is cupped out  $\frac{1}{4}$  in. deep as shown to prevent its slipping off the head of the rivet. The bar is placed as shown in Fig. 2, with the end on the bottom water leg rivet, which is the first one applied. A wooden block, *A*, of a thickness to suit, is then placed in the position shown. A hot rivet is placed in the hole, the bar is placed against the rivet, and pressure is exerted by the helper against the end of the bar in the direction indicated by the arrow. In this instance the heel of the holding on bar acts as the fulcrum, the rivet head as the load, and the pressure exerted on the end of the bar as the weight.

Enough succeeding rivets are held on in this manner, going upward along the flange, until the bar can be turned as shown in Fig. 3 and the heel used to hold the rivets. Bolts *B* are inserted through staybolt holes in the side sheets for the block to rest upon; the bar is turned and the pressure is exerted in the direction of the arrow.

As the riveting progresses upward on the side flanges, the bar

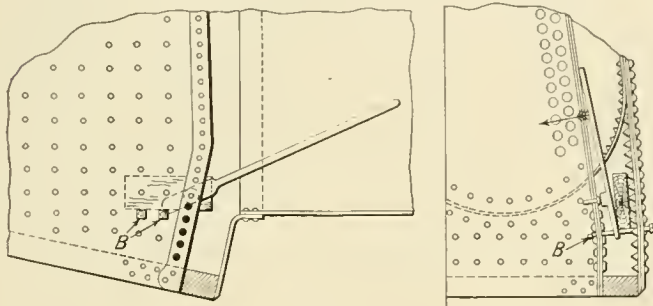

Fig. 3

assumes a more horizontal position as in Fig. 4. The angle iron *C* is now bolted to the flue sheet, and the rivets held on as shown until the top corners are reached. Across the top flange an ordinary holding on sledge is used with a countersink to receive the rivet head.

As these sheets are fitted up perfectly before any riveting is done, there is no slack; therefore starting the riveting at the bottom does not make any difference. On account of the flanges being scarfed, and also as all rivets are caulked as soon as driven, while the holding on bar is still on the rivet, it has never been considered necessary to caulk the seams. Tube sheets applied in this manner have run three years and have never been caulked

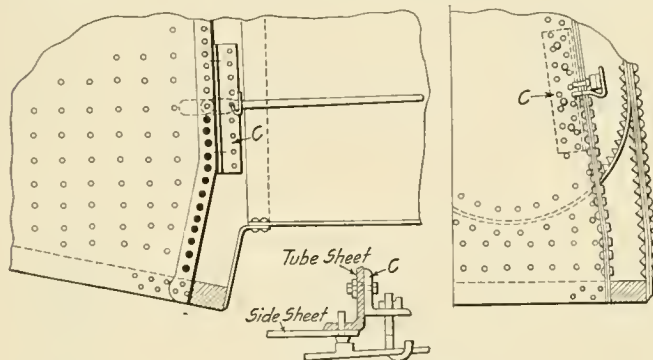

Fig. 4

either on the fire or water side. The only leaks ever noticed were during the hydrostatic test after applying the second set of tubes, when the top edge along the crown sheet would be slightly sprung but not enough to require caulking.

After the water space rivets are finished the mudring rivets are applied, using two riveting hammers, holding on the outside with a button die and driving inside on the new sheet, using a flat die. The corner rivets are driven in the same manner, except that the holes inside have a deeper countersink. These sheets have 103 flange rivets and 54 mudring rivets. All riveting is generally

completed in one day of 10 hours by one boilermaker, one helper and a rivet boy. This can be considered a good performance when the extra work necessary to get the sheets absolutely iron to iron, to avoid the necessity of caulking the seams, is taken into consideration.

In applying side sheets, the sheets are laid out, the top seam is scarfed as in the case of the tube sheets, and  $1\frac{1}{16}$  in. lap is allowed for  $\frac{3}{4}$  in. rivets. After the machine work of countersinking the rivet holes is done, the sheet is applied to the firebox, placing temporary bolts in every third hole and laying up the laps thoroughly. The holding on bar shown in Fig. 1 is used with

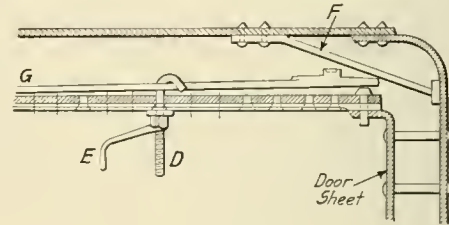

Fig. 5.

an extra long handle to enable the helper to stand in the barrel of the boiler. This bar is placed in position as in Fig. 5, using the hook *D* for a support. This hook is made with the least possible amount of bend at the end, to enable a workman driving rivets on the firebox side to change the hook from one hole to another; the helper meanwhile guides the bar. The threaded nut has a handle *E* to facilitate the work, doing away with the necessity of handling any wrenches. Where the backhead braces, as at *F* Fig. 5, are too close to the door sheet flange, the holding on bar is turned as shown. Rivets are held in this manner until the bar can be turned over and the heel placed on the rivet heads, as in Fig. 6.

To apply a rivet to a hole, the handle *E* is turned backward to loosen the hook, and the bar is pulled forward to provide room to enter the rivet. The helper then places the rivet in the hole, using long spring tongs; in this he is assisted by the boiler-

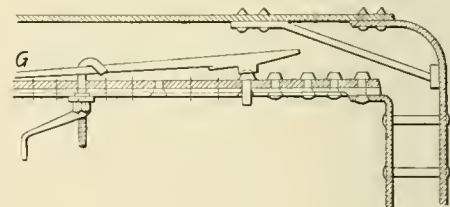

Fig. 6

maker, using a hook inserted in the next rivet hole or in a staybolt hole, as is most convenient. After the rivet is in the hole, the holding on bar is placed on the head by the helper; the boilermaker in the firebox meanwhile tightens the nut of the hook until the bar rests on the sheet at *G* and is also hard against the rivet head. This puts a spring in the bar, causing the rivet head to draw up tight as the boilermaker drives and caulks it. There is very little work necessary for the helper except to guide the bar on the rivet, as the real work of holding on is done by the spring in the bar. The hook is used until within six or eight rivets from the tube sheet flange, when the angle iron is used, as in Fig. 4, to hold the balance of the rivets in the side sheet seam.

To drive the rivets down the door sheet flange, the side sheet is wedged out slightly at the bottom and the holding on bar and hook are used in the same manner as on the side sheet, except that the bar is at an angle of 45 deg. with the seam, instead of in line. The side sheet seams are never caulked.

This method of holding on rivets has many advantages over some of the other methods of using wedges and cups to suit various water spaces, requiring an extra helper to use the sledge on the wedge bars.







5, it is now possible to lay out a time schedule for the entire work in the different departments of the shop. This schedule is based on the master schedules shown in Figs. 6 and 7, and is varied slightly to suit different types of engines. When it is desired to limit the shop expenditure to a certain amount, a careful selection of engines is made, shopping only those re-

should be completed, and from them are prepared typewritten sheets like that shown in Fig. 8. These sheets are prepared daily and are in the hands of the various foremen by 8 a. m. They show each foreman just what work he should complete that day for each engine in the shop. In case something has arisen to prevent his completing certain work on the day previous, that work is again placed on his list and an X placed in front of it, indicating that it is a day late. An additional X is placed before the operation on each succeeding day that it remains uncompleted. It will readily be seen that this serves as a constant reminder to the foreman that he is behind in his work, and that steps will have to be taken to catch up with the schedule if the engine is not to be delayed.

A large sheet, combining the schedules for all engines, is kept in the schedule office and used with a straight edge by the schedule clerks for their guidance.

A list of all material that is late is also prepared daily for the

SCHEDULE FOR NO. 2 REPAIR  
Machinery Shop

Day in Shop	Engine Shop	Boiler Shop	Struct. Shop	Paint Shop	Blacksmith Shop	Foundry Shop	Turn. Shop	Drill Shop	Lathe Shop	Welding Shop	Wire Meshing	Striking up Parts	Text. Shop	Trans. and Carriage Shop	Paint Shop	Day in Shop
1	Off wheel and straighten for new Gironson. Smoke box interior's report in 2 in.															1
2	Stripplate turned. Boiler work started. 2 in.															2
3	Boiler work started. 2 in.															3
4	3 in. takes out. 2 in. takes out.															4
5	3 in. takes out. 2 in. takes out.															5
6	3 in. takes out. 2 in. takes out.															6
7	3 in. takes out. 2 in. takes out.															7
8	3 in. takes out. 2 in. takes out.															8
9	3 in. takes out. 2 in. takes out.															9
10	3 in. takes out. 2 in. takes out.															10
11	3 in. takes out. 2 in. takes out.															11
12	3 in. takes out. 2 in. takes out.															12
13	3 in. takes out. 2 in. takes out.															13
14	3 in. takes out. 2 in. takes out.															14

Fig. 7—Shop Schedule for No. 2 Repairs

CANADIAN PACIFIC RAILWAY COMPANY  
ANGUS SROPS SCHEDULE OFFICE 3/6/14  
EAST MACHINE SHOP

Eng. No.	Material	Operations
840	1 R.B. Cyl. casing	Deliver
3476	Frict. gear	Deliver
	Stack	X Turn. Deliver
6125	Exhaust pipe	Deliver
	Stm. pipes (L.H.)	XX Rec. fr. Fdry. X Shape Del.
2513	Pistons	X Deliver
2113	Exhaust pipe	Turn.
	Smoke Box Front	Assemble
	Steam pipes	Shape
778	Frict. gear	Rec. fr. Foundry
	Pistons	Deliver
	Cyl. covers	Deliver
	Smoke box front	Rec. fr. Flange Shop
	Superheater headers	Plane
531	Sand box	X Turn. Drill
	Pistons	Turn.
	Buffer castg.	Deliver
	Center Castg.	Turn.
	Crossheads	X Key up Deliver
892	Pistons	Turn.
	Front cyl. heads	Turn.
997	Crossheads	Deliver
	Deck castg.	X Deliver
	Buffer castg.	Shape
	Crossheads	XX Babbitt X Plane Key up
999	Pistons	X Mill rods Turn rods
	Frame	Deliver
	Tail bare	X Deliver
	Sand box	Rec. fr. Foundry
6214	Crossheads	X Assemble Plane
	Expansion brackets	Plane
2750	Pistons	X Rec. fr. Fdry. (heads) Bore
	Cyl. (L.H.)	Rec. fr. Erecting Shop
	Cyl. bushing	Drill
	Valve bushings	Will
3040	Crossheads	Assemble
	Frames	XX Rec. fr. Smith Shop X Plane Slot
	Frame fillers	Plane
	Deck castg.	Rec. fr. Smith Shop
6051	Top rails	X Rec. fr. Smith Shop
2226	B. Cyl. head (L.H.)	Rec. from Foundry
1014	Cyl. (R.H.)	Bore
3382	Rep. mat.	Rec. fr. Erecting Shop
<b>New Engine Material</b>		
2661	Frame fillers	Deliver
	B. Cyl. covers	Deliver
	B. Val. covers	Deliver
	Center castg.	X Deliver
2662	Steam pipes	Deliver
	Stack & Hood	Deliver
2663	Cyl. & Valve casings	Deliver
	Friction castg.	Deliver

Fig. 8—Operation Sheet

benefit of the superintendent of shops and the erecting shop foreman. Orders for any further material, as mentioned in a preceding paragraph, or material which is necessary because of improvements in design, are passed through the schedule office and a record made on a special card form for reference by the schedule men when making out detail schedules.

As the various operations necessary to completion fall due they are daily added to the foreman's operation sheet. It will be seen by examining the operation sheet in Fig. 8 that foremen and charge hands are not only given advance notice of the work which they will have to commence on any particular day, but are reminded every day of the work that has been permitted to fall behind. The chance of any one item being lost sight of is thus reduced to a minimum.

The schedule men follow the progress of the work on the

quiring No. 1 or straight machinery repairs without firebox work, under which conditions a very accurate estimate can be made. The master schedules give the day, based on the date that the engine is brought in the shop, on which each part of the work





# A CHEAP METHOD OF MAKING BRAKE SHOE KEYS

BY E. A. MURRAY

Master Mechanic, Chesapeake and Ohio, Clifton Forge, Va.

A new method of manufacturing brake shoe keys is in use at the Chesapeake & Ohio shops at Clifton Forge, Va. By employing the machine shown in the illustrations it has been found possible to reduce the cost of making these keys from 1.75 to 0.4 cents each. The output of one blacksmith formerly was 400

offset slab to which is fastened an air cylinder. The piston of this cylinder is connected to a gear rack, which in turn engages the gear segment, the back of which acts as a former for the key.

This device is the invention of R. L. Woodrum, smith foreman at Clifton Forge, Va.

## EFFICIENCY

BY ROBERT W. ROGERS

Instructor of Apprentices, Erie Railroad, Port Jervis, N. Y.

There has been so much talk on safety first and safety always, that it seems well to call to mind that if anything is done efficiently it will be done safely. There are several considerations that railway employees should bear in mind in carrying out the idea of efficiency.

Beginning at the bottom of the ladder, the laborer can often save much time in accomplishing his work. He frequently walks a greater distance than is necessary; and how often three men are called upon to lift a weight when two would be sufficient. The tools supplied the laborer are often inadequate, or they are not the proper kind; a shovel that is too long or too short is difficult to use and wastes time. A gang leader can get improved results very often by studying how best to use the men and tools furnished him.

Machinists, boilermakers, blacksmiths, and all other shop men should learn to use their tools to produce the best results in the shortest time. A good man in any of these lines of work must have initiative; in these days of piece work, it is becoming more and more necessary for the rapid turning out of good work, if the man is to make a good income.

The more efficient a man is the more money he makes. In doing any job, it is the worker's first duty to see that his machine or tool is in proper condition, that no one is likely to be struck by the moving parts of the machine or by flying chips, and he should plan his work so that he may know just how the various steps follow each other.

The supervising force in any shop should first see that

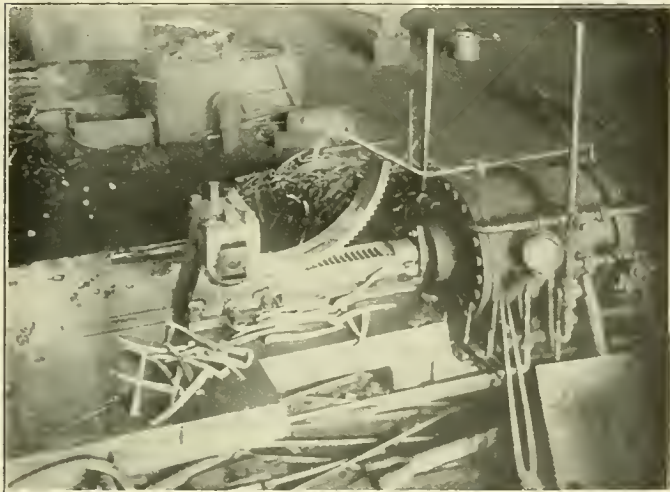

Machine for Making Brake Shoe Keys

keys per day. The use of the device illustrated has accomplished an increase in the shop output to 4,000 per day, and with the use of much cheaper labor.

It will be seen by referring to the engravings that the keys are made from 1/2 in. by 1 1/4 in. flat iron. The first operation is to cut the stock to 12 in. lengths, after which it is sheared diagonally by the special shear blades shown, making two keys

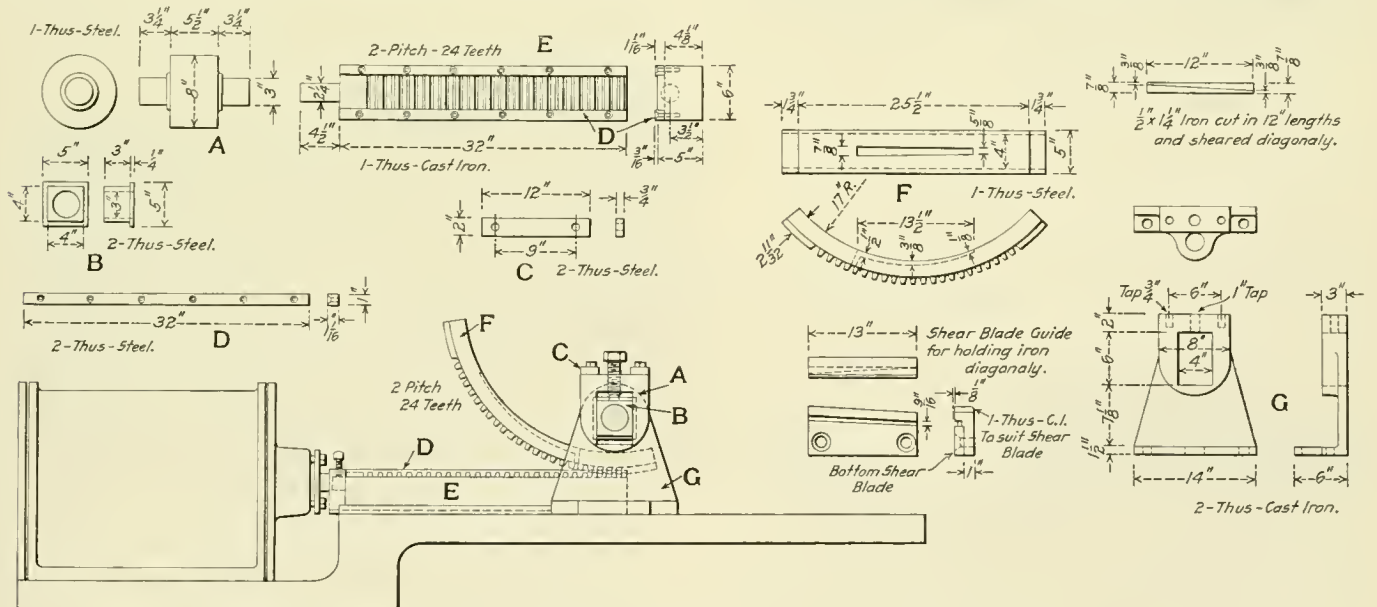

Details of Machine Used for Making Brake Shoe Keys on the Chesapeake & Ohio

out of one length. The second operation consists of heating the iron and rolling it to shape. The tool used in the operation is designed so as to turn the gib on the end of the key and roll it to the proper length and radius in one operation.

This work is accomplished on an ordinary bending machine, common to almost any railway smith shop, consisting of an

the workmen are protected from injury, and then intelligently direct them in their work. They should always be ready to supply advice, when needed, as to how best to perform a job. Such co-operation between the supervising force and the workmen is bound to give more correct and rapid results in turning out work.



# LOCOMOTIVE AND CAR REPAIR NOTES

BY W. T. GALE

## REPAIRING INJECTORS

When removing injectors, the repair man will often use a hammer and set in loosening the nuts instead of using the proper wrench. This practice will knock the injector connec-

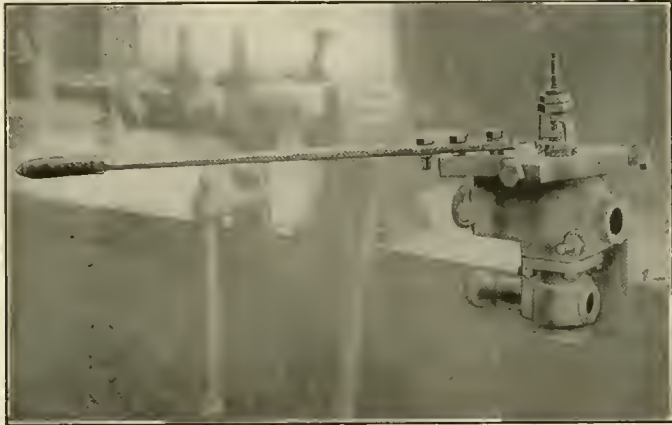

Fig. 1—Application of Jig for Reducing Injector Connections

tions so much out of shape that in time it will be impossible to make a tight joint. The tools and jigs shown in Figs. 1, 2 and 3 are used to contract or expand these holes and bring

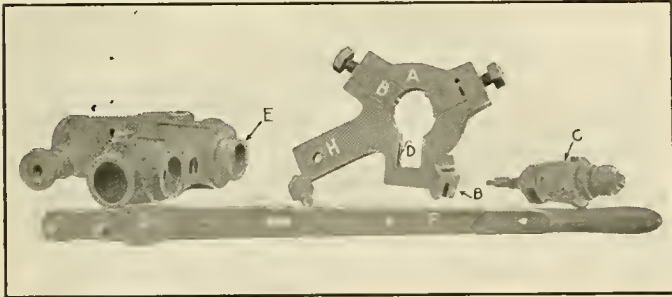

Fig. 2—Jig for Reducing Injector Connections

them back to the proper size, which in many cases will save scrapping an old injector. Fig. 1 shows how the contracting tool is applied to reduce the size of the connection so that the

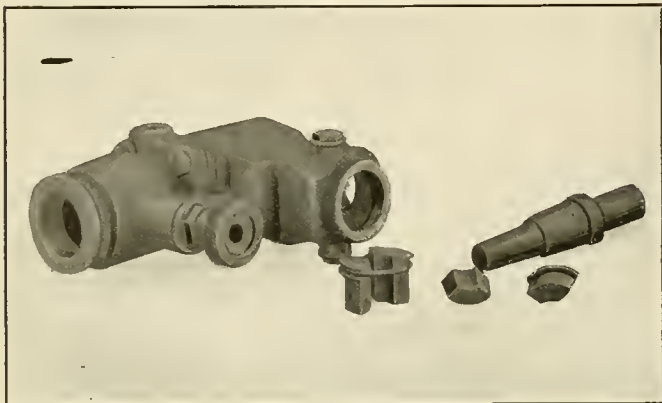

Fig. 3—Jig for Expanding Injector Connections

bonnet will have a snug fit, and Fig. 2 shows the construction of the jig. The body *A* contains three slots for the adjustable block *B*. Each block has a small steel roller which rolls the injector connection back into shape. The blocks are held in

place by a pin *D* on each side of the slots, and they are forced in by a set screw. The handle *F* is applied to the body at *H* and is long enough to give sufficient leverage to turn the jig after the set screws have been set up. One of the connections which is to be closed up is shown at *E*, and *C* is the plug which is screwed in the connection while it is being rolled. The expander is shown in Fig. 3, and consists of a sectional steel bushing and a tapered plug. The inside of the bushing is bored to correspond to the taper of the plug and the outside contains a groove for a steel snap ring to hold the four sections in line. The bushing is made to fit the smallest hole to be expanded, the taper in the plug taking care of the larger holes.

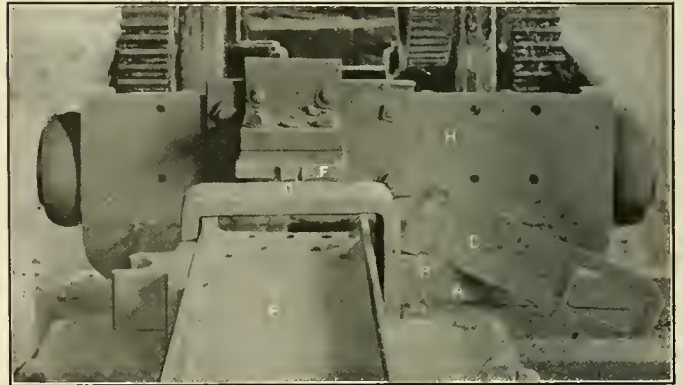

Fig. 4—Bulldozer Equipped for Shearing Rivets from Truck Transoms

The plug is driven in by a hammer and the bushing is turned frequently to prevent ridges forming on the inside of the hole.

## RECLAIMING CAR TRUCK TRANSOMS

An inexpensive method of shearing rivets from freight car truck transoms is shown in Figs. 4, 5 and 6. A No. 4 Williams & White bulldozer is equipped with the shear *F* as shown in Fig. 4. This shear is bolted to two heavy angle bars, which are riveted to a plate and the plate is bolted to the face of the bulldozer. The transom is held as shown in Fig. 5. It is raised to the proper height by the wedge *A* and the bar *B*, the

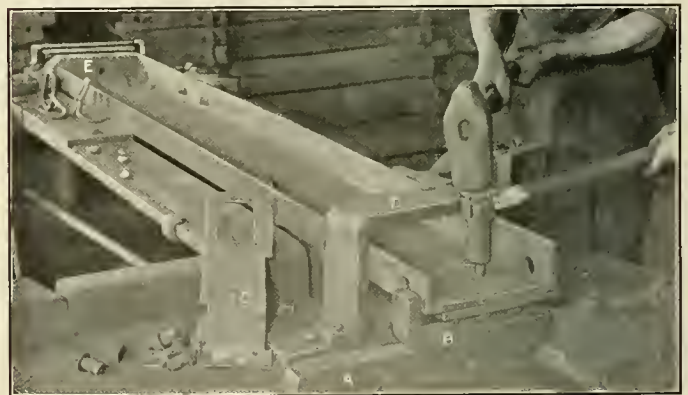

Fig. 5—Holding the Transom While the Rivets Are Being Sheared on a Bulldozer

gage *C* being used to measure the height above the table. A bracket *D* is placed over the channel to prevent it from moving out of position. The thrust of the shear is taken up by the back stop *E*, which is rigidly clamped to a heavy block foundation. The rivets in the flanges are removed by a small shearing tool under a steam hammer, as shown in Fig. 6. This method saves considerable time in removing the 22 rivets in each one of these channels, as with the old hand process only 18 channels could be finished in a ten hour day, whereas with this

method 145 channels can be reclaimed in the same time. With the channels shown in the accompanying illustrations seven rivets are sheared at each stroke of the bulldozer. Fig. 5 shows the method of driving out the sheared rivets. After all

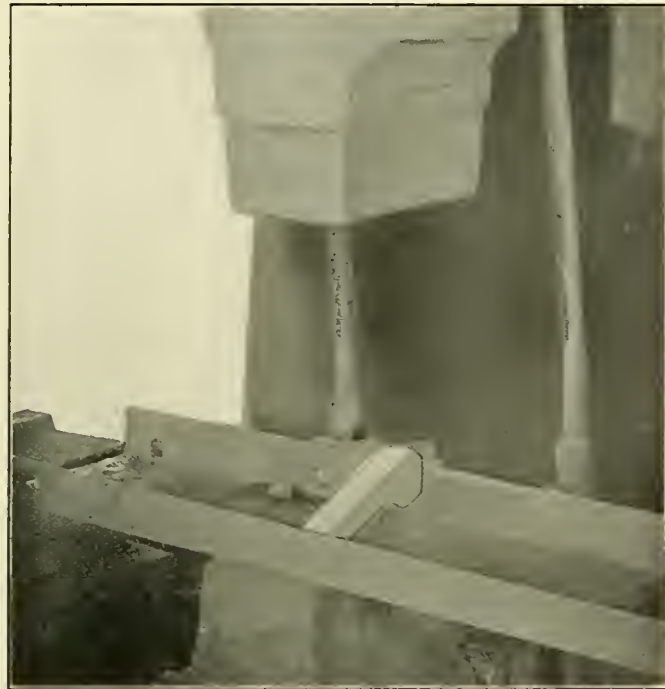

Fig. 6—Shearing Rivets from the Flanges of Truck Transoms

the rivets are removed the channels are straightened and used again.

REPAIRING VALVE SPINDLES

A tool and jig used for facing back the threads on valve

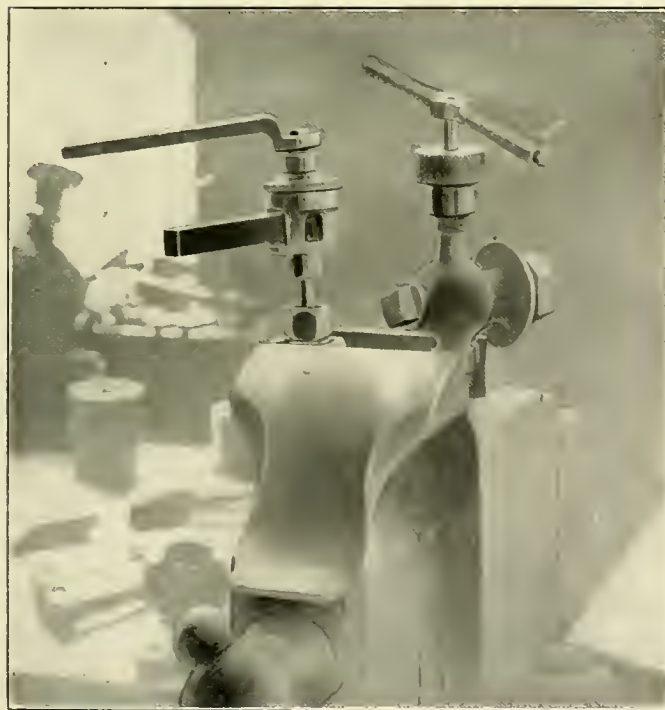

Fig. 7—Jigs for Repairing Valves

spindles is shown in Figs. 7 and 8. The spindle is held in a vise and the jig *A*, Fig. 8, which holds the tool, is screwed down over the stem. The tool *B* has a hole through it which

fits over the small end of the valve spindle, and the bottom is made similar to an end reamer. The tool is held central in the jig by the cover plate *C*, which screws into the jig and bears on a shoulder on the tool. The tool is turned by the wrench

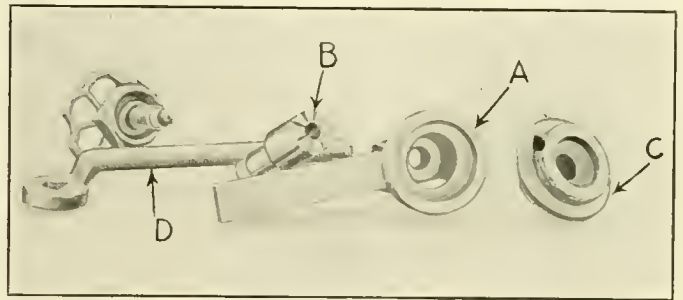

Fig. 8—Details of Jig for Repairing Valve Spindles

*D* and is driven down by screwing the cover plate further into the jig *A*. This device will be found valuable in the engine house for such work and modifications of it have been used to finish off the valve seats of water glass and gate cocks.

CHUCK FOR TURNING ECCENTRICS

BY PAUL R. DUFFEY

The chuck shown in the engraving is used to hold locomotive eccentrics in proper alinement with respect to throw, for turning the outside face. Fig. 1 shows the base plate, which may be altered in design to suit the machine on which the work is done. The four studs *A* are used to hold the main chuck plate, Fig. 2. This plate is drilled at *B* so that it may be shifted a reasonable distance on the studs *A*. The eccentric rests on the face *C*,

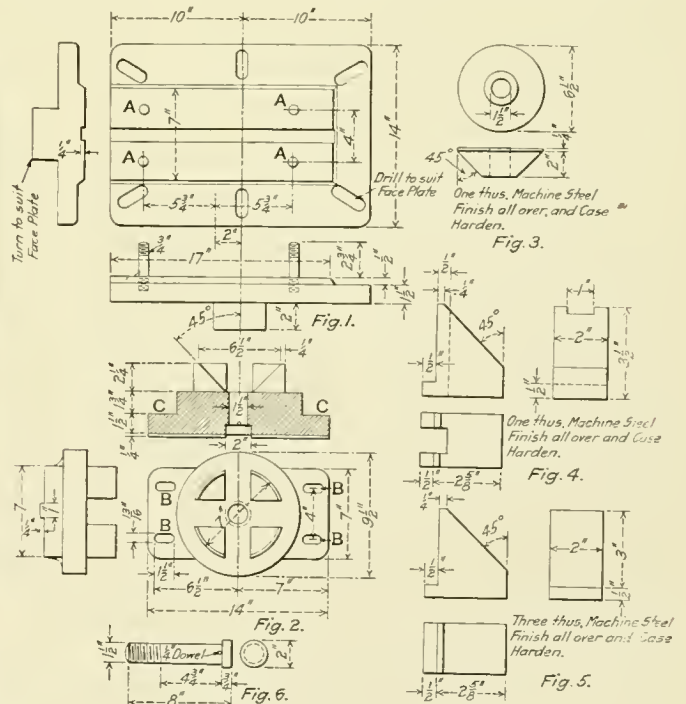

Details of Chuck for Turning Eccentrics.

Fig. 2, and is held rigid by means of the dies, Figs. 4 and 5. These are pressed against the sides of the eccentric by means of the expanding plate, Fig. 3, being pulled down to place by the pin shown in Fig. 6. The die, Fig. 4, is slotted to engage with the keyway in the block, which helps to insure proper alinement as well as providing an extra means of clamping.



## ADJUSTABLE PLATFORM FOR CAR SHOPS

BY GEORGE E. McCOY

The adjustable platform shown in the line engraving is in use in the passenger car paint and repair shops of the Canadian Government Railways at Moncton, N. B. The construction is shown clearly in the illustration. The plank which forms the platform has two truss rods and king posts strengthening it below. This plank is supported at either end by a bracket which is so arranged that it can be raised and lowered by means of

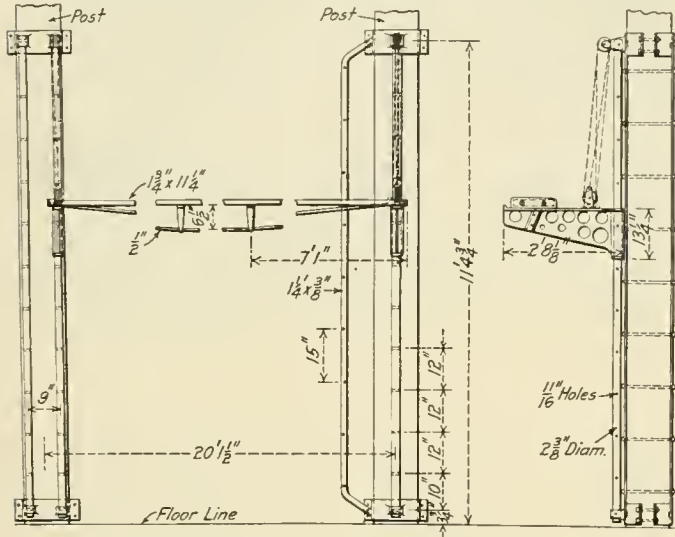

Adjustable Platform Used on the Intercolonial

pulleys and a hoist. The brackets are guided by 2 in. pipes supported against the shop posts. These pipes are drilled every 12 in. with 11/16 in. holes, and the brackets rest on pins which are inserted in these holes. A ladder is provided at one end of the platform as shown.

## SOME MODERN METHODS OF WELDING

Thomas Heaton, member of the Institution of Mechanical Engineers, presented an interesting paper before that society February 20, 1914, on electric and gas welding systems. Mr. Heaton described briefly the different systems in general use today. He believes that this new type of welding is much better for certain classes of work and produces far better results than the old method of welding in the coke fire. As regards the gas used for gas welding, it was believed that acetylene gave the best results, and of the electric processes, that the electric arc was more suitable. It was also stated that both the gas and the electric systems have fields of their own, and were economical when used in their own spheres. In general, however, he also believed that the electric is far more effective because the heat is produced within the work itself, whereas the heat of the gas flame is applied entirely from the outside. Where work is suitable for the electric arc, welds can be made far more quickly than by the oxy-acetylene flame. Concerning the strength of the weld he spoke as follows:

"The character of the metal at the weld is changed to some extent when welded by these processes. It loses some of its ductility and some of its strength, but loses far less than does a blacksmith's weld. Many tests have shown that 89 to 96 per cent of the original strength of the metal can be relied on in the electric welds. It has been said that the electric welding hardens the metal by filling it with carbon from the electrode. This is not the case. For example, in welding mild steel the fierce heat of the electric arc burns out all the impurities more

or less, including the carbon, and leaves the metal at the weld pure iron. If any hardening defect has ever been found it has been due to bad manipulation, or to the fact that the metal was never of a proper weldable quality, or the polarity was wrong."

The accompanying tables show the effect of the welding upon the metal. The plates were tested mechanically, both longitudinally and transversely along the welded joint, and for comparison, the unwelded metal is used. The results of the mechanical test of the unwelded metal are the mean of three lots. The chemical analyses and the mechanical tests were made in August, 1913, by F. C. Tipler, chief chemist, locomotive department, London & North Western Railway, Crewe. The pieces of material were prepared at the works of the Steel Barrel Company, at Uxbridge, and were of Siemens-Martin open hearth steel 1/8 in. thick.

TABLE 1—CHEMICAL ANALYSES

	Electrically welded		Acetylene welded	
	Unwelded metal Per cent.	Welded joint Per cent.	Unwelded metal Per cent.	Welded joint Per cent.
Silicon .....	0.009	0.003	0.009	0.002
Carbon .....	0.15	Trace	0.15	Trace
Sulphur .....	0.025	0.020	0.085	0.071
Phosphorus .....	0.068	0.043	0.068	0.067
Manganese .....	0.64	0.27	0.49	0.34
Iron (by difference)....	99.108	99.664	99.198	99.520
	100.000	100.000	100.000	100.000

TABLE 2—MECHANICAL TESTS ON MILD STEEL 1/8 INCH THICK

	Electrically Welded			Acetylene Welded		
	Unwelded	Welded joint		Unwelded	Welded joint	
		Transverse	Longitudinal		Transverse	Longitudinal
Elastic Limit Tons per sq. in. }	15.20	17.60	Nil	11.76	11.60	Nil
Breaking Weight Tons per sq. in. }	26.66	{ 24.00 = 90%	{ 25.60 = 96%	{ 23.14 78.8%	{ 18.24 = 78.8%	{ 23.20 = 100.2%
Contraction of area Per cent. }	47.25	Nil	Nil	46.66	49.60	Nil
Extension on 4 inches Per cent. }	23.16	5.00	0.50	26.33	13.50	4.25
Extension on 2 inches Per cent. }	30.33	7.00*	1.00†	33.66	22.00‡	8.00

\*Broke in weld. †Broke outside gage length. ‡Broke clear of weld.

TABLE 3—MECHANICAL TESTS ON TWO STRIPS OF SIEMENS-MARTIN MILD-STEEL SHEET 1/8 INCH THICK.

	Breadth of testpiece Inch	Thickness Inch	Area Square inch	Maximum load		Extension on 4 in. length Per cent.	Reduction of area Per cent.	Remarks
				On piece Tons	Per sq. in. Tons			
1	1.480	3/8	0.185	4.06	21.95	32.03	29.63	Original
2	1.478	3/8	0.185	3.59	{ 19.41 = 88.428%	10.93	5.23	{ Electrically welded

INCREASING SIZE OF STEAM TURBINES.—There is an extraordinary development taking place in the size of the individual unit in the field of steam turbines. We were commenting a short while ago on the fact that a unit of 20,000 kilowatts had been built; yet during the past year one of this size and another of 25,000 kilowatts have been built, and it is stated that orders have been placed for four of 30,000 kilowatts and one of 35,000 kilowatts.—*Scientific American*.

WEIGHT OF LOCOMOTIVE "PUFFING BILLY."—The Board of Education, South Kensington Museum, London, has furnished the following particulars regarding the celebrated locomotive "Puffing Billy," whose centenary occurred last year. The weight of the engine in working order was 8 tons 6 hundredweight, and of the tender 4 tons 6 hundredweight, making a total weight of engine and tender in working order of 12 tons 12 hundredweight. At a speed of five miles an hour, "Puffing Billy" was able to haul about 50 tons, but on occasions as much as 70 tons was hauled at a reduced speed.—*Scientific American*.

# GRINDING WHEELS AND THEIR USE

## Discussion of the Character of Wheel to Be Used and the Speed at Which It Should Be Run

BY A. R. DAVIS

Tool Foreman, Central of Georgia, Macon, Ga.

In selecting proper grinding wheels for the various classes of work in the locomotive repair shop the following features must be considered: The rapidity of grinding or cutting desired; the total amount of work to be performed; the finish to be produced.

These three elements are usually of importance in the order given. The speed of a wheel and other operating conditions being the same, they are influenced as follows:

The rapidity of cutting is increased by using a coarser grit or softer grade of wheel.

The total amount of work performed by a wheel is increased by using a finer grit or harder grade.

The finish produced is improved by using a finer grit together with a softer grade.

Other considerations to be noted in selecting wheels are:

The kind of metal to be ground: Cast iron varies to such an extent that wheels should vary in like ratio to get the best results. Nos. 24 to 38 grit with combinations of grades varying with the hardness of the iron will prove satisfactory. Cast iron and hardened steel require wheels of similar grades.

Its forms (whether surface or edge work): The greater the area of contact the softer the grade of wheel that will be required. This is probably due to the fact that as the contact area is increased, the load increases in the same ratio and dulls the grits faster, making it necessary that the bond be more friable,

and pump rods, etc., ground on a plain cylinder grinder, and bushings and pins for motion work. On piston rods and valve yoke stems to get a good finish at an economical rate requires the adjustment of many conditions as follows:

The work should be turned with a coarse feed,  $\frac{1}{8}$  in. or over, leaving  $\frac{1}{64}$  in. to  $\frac{1}{32}$  in. stock to grind. This will reduce the cost of turning and the coarse feed helps to keep the wheel from glazing. The centers should be in good condition.

Rests should be placed at not less than 15 in. intervals and should have a positive feed. Spring rests will not prevent chatter on work that is out of round if heavy cuts are taken.

The work (.003 carbon steel and special alloy steel heat treated) should have a speed of from 30 to 70 ft. per minute, according to its diameter, the larger diameters having a much greater area of contact with the wheel and consequently a heavier load, should revolve at a slower rate to avoid chatter. The same wheel may be used on different classes of material by varying the speed of the work.

Using from  $\frac{1}{2}$  in. to 1 in. traverse per revolution will meet the average requirements and give a good output. To use coarse traverse requires slow working speeds and a grinding wheel of a suitable combination of grits, 24 and 46, and of a medium grading.

The depth of the cut bears an inverse ratio to the traverse

GRADING OF GRINDING WHEELS

Manufacturer.	Material		Extra soft	Very soft	Soft	Medium soft	Medium	Medium hard	Hard	Very hard	Extra hard	Special hard
Norton Co. ....	Alundum	Crystolon	...	E	I	M	Q	V	...	...	...	...
The Carborundum Co. ....	Carborundum	Aloxite	Z	W	T	P	M	O	G	D	Y	...
Safety Emery Wheel Co. ....	Emery	Carbondite	C	H	A	M	P	I	O	N	E	D
American Emery Wheel Works. ....	Emery	Carbolite	6	5	4½	4	3½	3	2½	1½	1	...
Abrasive Material Co. ....	...	...	G	I	...	...	M	P	...	S	V	...
Sterling Emery Wheel Mfg. Co. ....	Emery	Carundum	½	1	...	...	M	O	...	T	...	Z
Vitrified Wheel Co. ....	...	...	11	K	...	...	...	...	...	...	...	...
			...	1	...	...	...	3	4	...	...	...
			...	C	...	D	E	...	F	...	G	...

so that the dull grits may escape easier and require less pressure to allow the wheel to cut rapidly.

The speed at which the wheel runs and whether wet or dry: A wheel too hard or running too fast heats and glazes; if too soft, it cuts and wears away quickly. Silicate wheels are best adapted for tool and knife grinding.

Wheels should be harder for hand operation than machine fed; heavy feed or pressure causes excessive wear of wheels; high speed will cause excessive wheel wear.

In connection with selecting grinding wheels, the foreman is confronted with the arbitrary methods of grading used by the manufacturers. Many companies use the same grading for vitrified and silicate wheels, while some use separate grading for the latter. Most use a separate system for elastic wheels grading by numbers, 1 to 11, and using fractional numbers.

The accompanying chart shows the variation of the grades. This is very confusing to the shop man as few can keep in mind the different gradings in comparing wheels of different makes, and it has undoubtedly been the cause of many failures in securing proper duplication of wheels. It also makes it difficult to recommend a grade of wheel without including the maker.

Railway shop grinding may be classed as cylindrical, surfacing, hand and tool.

Of the cylindrical grinding, we have piston rods, valve stems,

and can be increased as the traverse is decreased. As a general rule there is less wear on the wheel with a greater traverse and less depth of cut. An average of  $\frac{1}{4}$  cubic inch of stock per minute can be removed without chatter.

Chatter marks, flats parallel with the axis and spiral mottled marking at irregular intervals, are caused by the vibration of the wheel and work acting together during the grinding, the wheel cutting the work as it vibrates. Some wheels will chatter and some will not on the same class of work. The mottled or spiral chatter is nearly always caused by the vibration of the machine, a wheel out of balance or a spindle loose in the bearing.

Plenty of water and the proper location of the nozzle are necessary for good work. The nozzle should be placed to have the water strike the wheel just above the point of contact with the work and not in a wide thin stream, since the air currents from the sides of the wheel will spray the water on both the machine and the operator.

This class of wheel should be trued with a carbon stick or other points affording a rigid tool to face the wheel. A hand held dresser will not leave the wheel in condition to produce fast work with a good finish. A loaded wheel is one that has particles of metal adhering to its face and filling in the crevices of the wheel, causing heating. A glazed wheel has its cutting particles dull and worn down even with the bond. Using a dresser



is not truing, but sharpening a wheel, and should not be done on a wheel used to grind work on centers. In truing wheels, the carbon or diamond points should be held rigid, as a wheel must be a true cylinder to produce a true cylinder.

In grinding case hardened valve motion work, bushings, pins, etc., on a dry cylindrical grinder, wheels of 46 or 50 grit and of a medium to a medium soft grade give good results for external work, the amount of stock to be removed being small. For the internal grinding of bushings a 50 to 60 grit and a medium to a medium hard grade will give a quick and a good finish.

Of locomotive parts, for the surface grinder there are guide bars, slide valve faces, valve strips, links, drop forged valve stem and piston rod keys, rod keys and liners, etc. In grinding machinery steel guides on a face grinder with a 30 in. cup wheel, dry, a table travel of 10 ft. per minute gives a good finish and a quick job, doubling the output of the wet wheels previously used.

For this a wheel of a combination of grains and grades, 141-N-SNTS (Carborundum grading) cuts fast and cool and produces a chip resembling the ordinary chip from a face mill. The wheel should be kept true and the work clean. The feed will be governed by the width of the face ground, but should be uniform. A wheel of this class will remove stock at the average rate of 1 cubic inch per minute.

Slide valves, valve strips, links and plates for motion work, drop forged valve stems and piston rod keys, pump packing rings, liners, etc., are ground on a vertical surface grinder with a 12 in. cup wheel using a magnetic chuck for holding the work. With a table speed of 6 to 10 ft. per minute and feed in proportion to the width of the face to be ground, grinding has proved the most economical method of machining as well as producing the best finish for a wearing face. For grinding cast iron, silicate wheels of a combination of grits 30 and 38 and of a medium soft grade give clean rapid work; .4 cubic inches per minute should be removed. Slide valves will average 3 cubic inches of stock removed.

For case hardened steel and drop forgings a silicate wheel of a combination of grits 24 and 38 and of a medium soft grade gives good results.

For tool steel, carbon and high speed, a wheel of 30 grit, medium grade, will cut rapidly and remain cool.

We have found it more economical to grind shear blades, inserted blades for large milling cutters and reamers, bolt cutter dies, car wheel boring tools and all tools of this class, from the rough, instead of milling or planing, where the amount of stock is 1/16 in. or less. This class of machine can remove 30 cubic inches an hour and should have a heavy flow of water. The power required under full load will be about 10 h. p.

Wheels of 40 to 50 grit and of medium to a medium hard grade have given good results on links in the radius grinder. A traverse of 12 ft. per minute with a feed of one-half the wheel face and a cut of .002 in. depth will produce rapid work with a good finish.

In placing wheels of large size in the various departments for general use, the smith and boiler departments require the harder grade of wheel, as the bulk of the grinding is on the edges. A 16 to 20 grit and a medium hard to a hard grade will meet these requirements. For the general work in the erecting and machine shop departments on work that replaces the chisel and file, a wheel of 24 grit and a medium to a medium hard grade will cut free on most of the material used except brass. This can be handled to better advantage on a disk grinder with a 16 grit. This applies to rod brass work especially, the disk grinder being an economical method of facing halves of split bushings.

For lathe and planer tools a wheel of 24 grit and medium hard grade gives good service for hand grinding, while the same grit but of a slightly softer grade cuts cooler and faster in the machine fed tool grinders.

In connection with tool grinding, high speed steel should be ground dry or with a large stream of water. For grinding finished tools in special machines, wheels of from 46 to 60 grit and

medium to medium soft grades for both cylindrical and surfacing, cut fast and cool. For form grinding, threading dies in the throat, etc., a wheel of 50 grit and just below a medium hard grade will hold its shape and cut fairly fast.

## FEED VALVE TEST RACK

BY J. A. JESSON

Air Brake Foreman, Louisville & Nashville, Corbin, Ky.

The drawings show a quick action device for testing feed valves. Fig. 1 gives a side view of the device attached to a bench. It consists of a body *A*, a clamp yoke *B*, a 5/8-in. screw *C*, a handle *D* and cap screws *E*. Fig. 2 is a top view and Fig. 3 shows the clamp yoke *B* when in position for releasing the valve. The pins *F* are for guiding the valve to position on the face of the body *A*.

In operation, the yoke is raised as shown in Fig. 3, the valve is placed over the pins *F* and against a 1/16-in. gasket. The yoke is then placed in the position shown in Fig. 1 and the tightening of the screw *C* causes the yoke to pull the valve against the face of the body *A*. The sides of the yoke are slotted to allow for longitudinal movement. A slot is cut across the corner of the

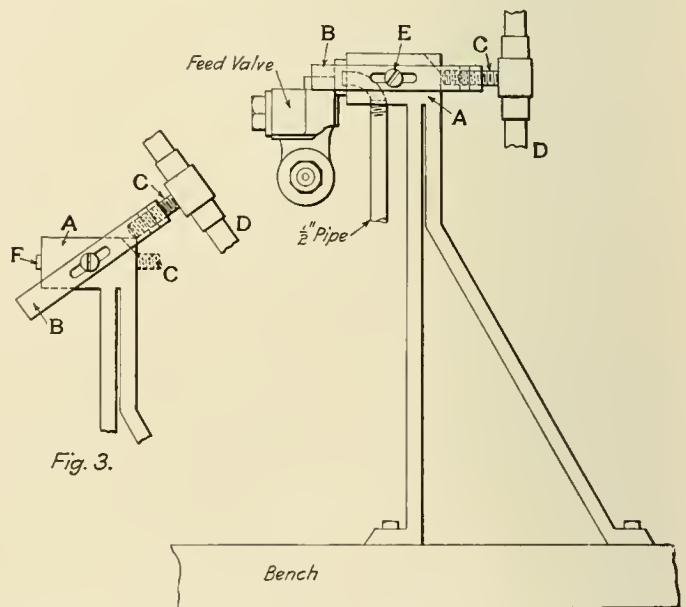
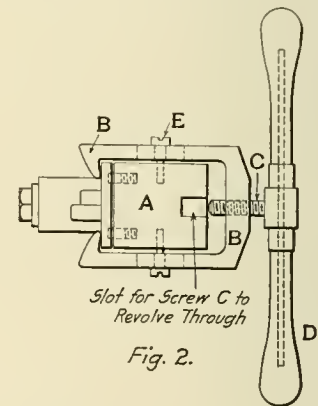

Fig. 1.

Feed Valve Test Rack

body, which permits the yoke to revolve as soon as it is released sufficiently to clear the valve. The 1/2-in. inlet and outlet pipes are tapped into the lower side of the body. The drilled ports are thoroughly tinned to prevent leakage. The device is made of machinery steel and is amply heavy to withstand shocks.

# NEW DEVICES

## BRIDGEFORD GAP AXLE LATHE

A center drive gap axle lathe with two carriages, designed specially for use in railroad shops where it is desired to turn the journals of car axles without removing the wheels, is shown in the accompanying illustrations. This machine has been de-

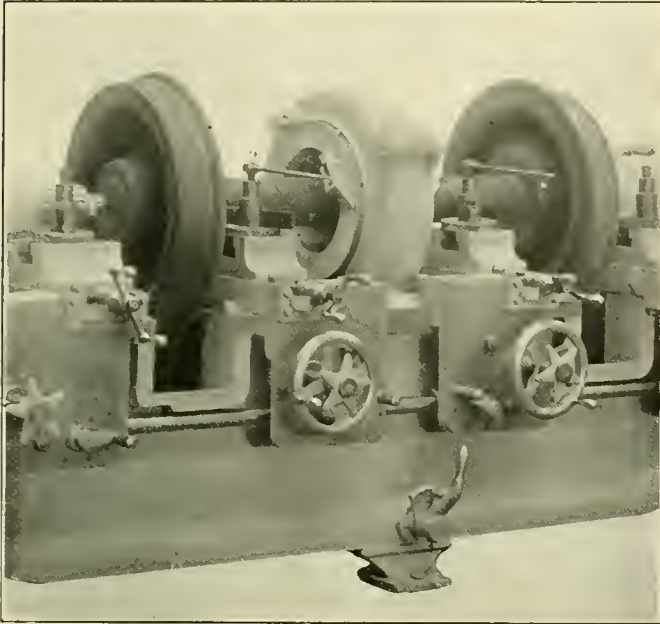

Lathe Equipped for Axles with Journals Between the Wheels

signed and is built by the Bridgeford Machine Tool Works, Rochester, N. Y., and in construction is very similar to the other axle lathes built by this company.

This machine is designed to be placed in a pit so that the axles

hinge bolts. These fastenings can be released with less than one-half turn of each nut and the upper half of the driving head operates on a heavy hinge stud placed in the front of the machine. To lift it, the pull pin is pushed in place and the nuts are released. An eye bolt is placed on the upper half of the head and to this can be attached a rope with counterweights operating a set of sheaves.

The driving head throughout is very powerful and of heavy construction. The gear has a 5-in. face and runs in heavy bronze bearings scraped to a fit. The lathe is furnished with a self-centering steel driver plate operated on the same principle as on the company's previous axle lathes. The power is applied to a constant speed pulley at one end of the machine and if motor driven, is belted direct to the motor mounted on the driving end as shown in the illustration. There are three variations in cutting speed provided, which are controlled by a speed variator through a heavy steel gearing running in oil. The changing of speed is accomplished by shifting levers and the power is transmitted from the speed variator to the driving head by a shaft placed within the frame.

Four changes of feed ranging from 1/16 in. to 3/16 in. per turn of the axle are provided by a feed box. The lever shown in the center of the machine controls the feed.

The carriages are driven by a splined feed shaft through a rack and pinion. The direction of the feed is changed at the apron and the carriages are entirely independent of each other. They have a bearing on the Vs 30 in. in length and also bear on the back of the bed in a manner which will provide for taking up the forward thrust. In this way, any tendency to raise the carriages from the Vs when a burnisher is used is obviated.

If desired, this machine can be equipped with two extra inside carriages for refinishing locomotive and trailer axles with inside journals. This is shown in one of the illustrations.

Some of the general dimensions are as follows:

Distance between centers, minimum.....	54 in.
Distance between centers, maximum.....	105 in.
Swing over ways.....	27 in.
Swing over carriage.....	13½ in.

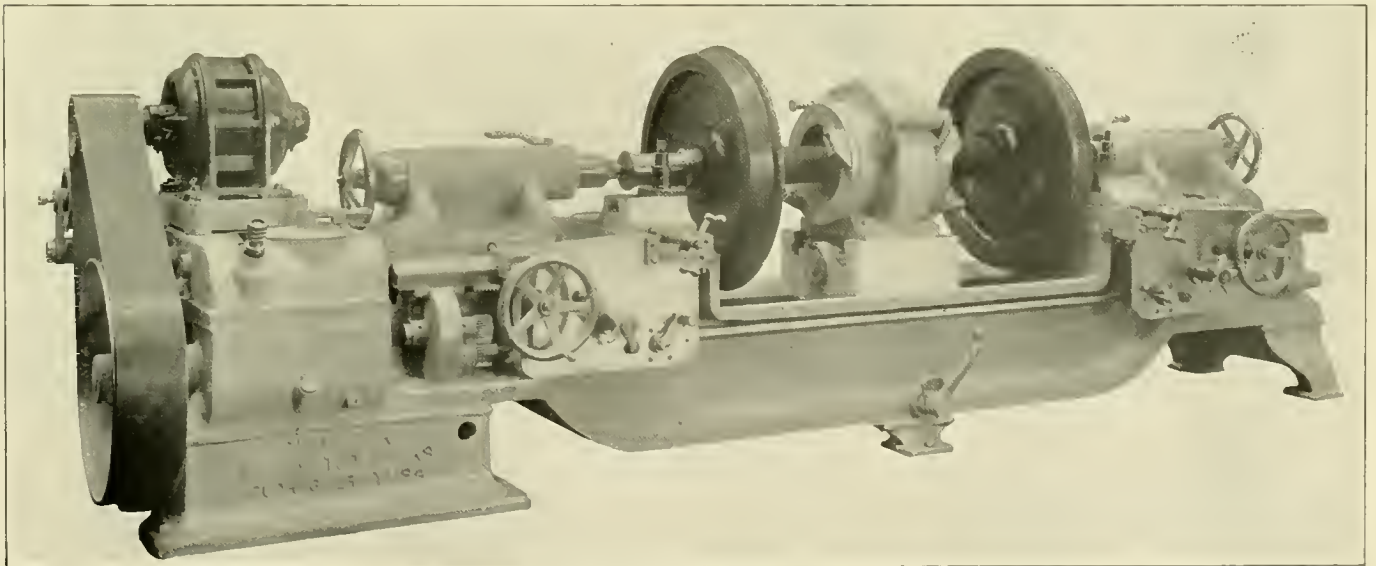

Center Drive Axle Lathe, with Gap for Refinishing Journals of Mounted Axles

with wheels attached can be placed in the centers very readily. The driving gear in the center is in two pieces of tongue and groove construction, bolted together by four heavy

Swing in gap.....	45 in.
Driving pulley.....	30 in. diam. for 8 in. belt
Weight of lathe with two carriages.....	16,000 lb.
Weight of lathe with four carriages.....	18,000 lb.



## DERIHON PORTABLE HARDNESS TESTING MACHINE

A machine for testing the hardness of metals according to the Brinell method, which is that of making an impression with a 10 mm. ball under a pressure of 3,000 kilogrammes, is shown in the engravings.

One of these shows the machine ready for the test, with the lever raised and resting on the shaft. The piece to be tested is placed on the table of the machine, which is then raised until the piece is in contact with the ball. The lever is then pulled slowly over so as to give a progressive pressure until 3,000 kgs. are applied. When this figure is reached the lever is slowly returned to its former position and the test is completed. The pressure is registered by a small manometer. Under normal conditions it is usually sufficient to move the lever through an angle of 45 deg. to obtain the required pressure.

With each machine a small piece of steel is furnished in which a standard impression has been made, the diameter being stamped on it. This standard piece is made of an air hardening nickel-chrome steel. The accuracy of the machine can be easily checked by making an impression alongside the standard impression.

The construction of the machine is based on the principle of elasticity of the frame, which for this purpose has been given the shape of a horseshoe. The power produced by the pressure

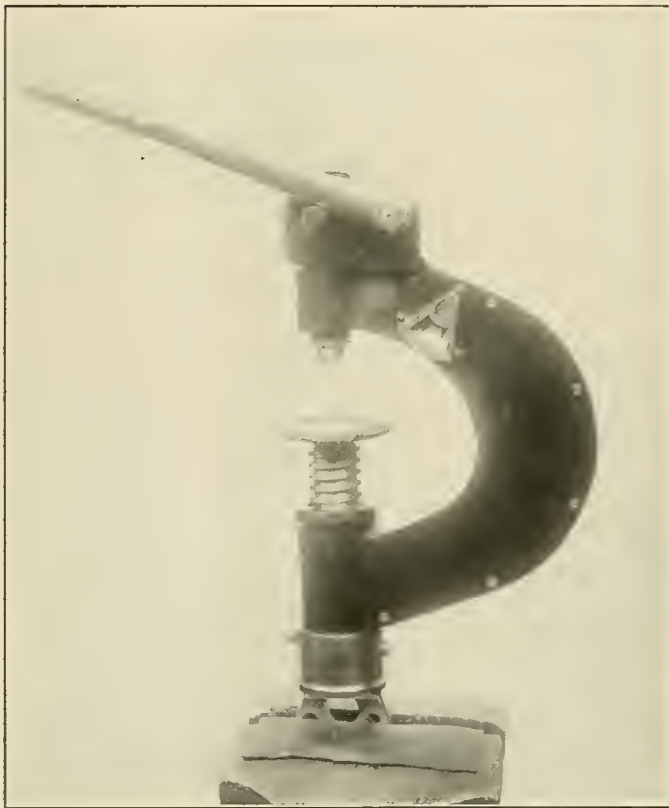

Machine Ready for Testing

of the ball on the test piece has a tendency to open the frame to a certain degree in proportion to this power. The shape of the frame has therefore been specially considered in order to have it as elastic as possible. The pressure of 3,000 kgs. does not at all change the resistance or elasticity of the frame, as it is made of an air hardening, nickel-chrome steel, having an elastic limit of 242,000 lb. per sq. in., and a pressure of 3,000, 4,000 or 5,000 kgs. does not stress it above 10 kgs. per sq. mm. (14,423 lb. per sq. in.). Under these conditions, repeated tests even in large numbers do not alter at all the calibration of the machine.

The deflection of the frame being relatively small (1 to 1.5 mm.), a register, the construction of which resembles a metal manometer, is installed in the hollowed out part of the frame. By means of a needle and a graduated dial, the deflection and therefore the pressure exerted in making the test, can be quickly and easily read.

To adjust the machine all that is necessary is to open the case enclosing the mechanism above the frame. Should the machine ever get out of adjustment, a comparison should be made on the standard piece, and when an impression of the same diameter

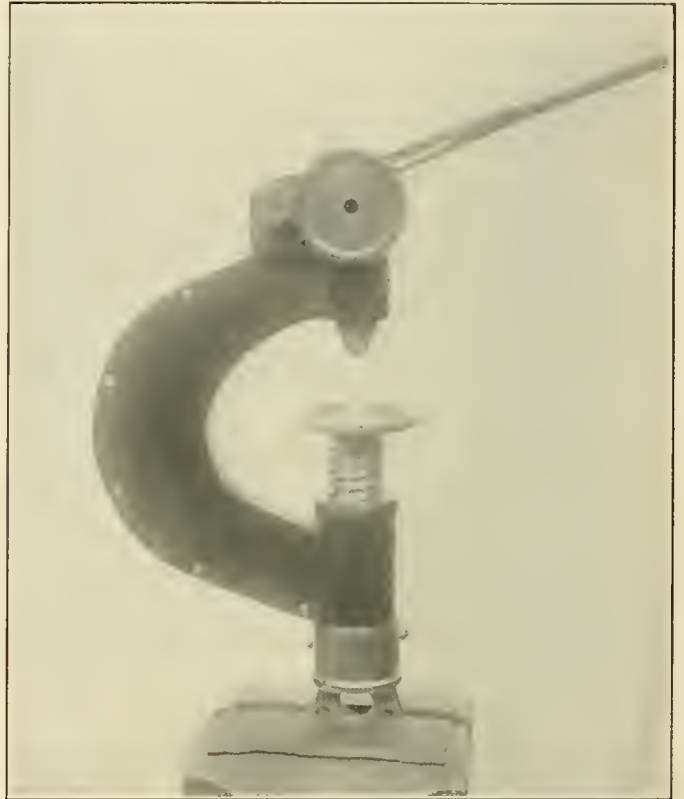

Arrangement of the Gears at the Rear of the Derihon Portable Hardness Testing Machine

has been made, the needle should be brought over the figure 3,000 by means of a small adjusting screw. This adjustment, however, would only be necessary through some accidental cause independent of the operation of the machine under normal usage.

The second illustration shows the arrangement of the gears at the rear. A portable case is provided in which the machine can be packed.

This machine is placed on the market by H. A. Elliott, 507 Majestic building, Detroit, Mich.

**CHINESE AS WORKMEN.**—Of all original workmen, states Eastern Engineering, the Chinese are undoubtedly the best, though there may be some with experience of both races who may be disposed to give the palm to the Japanese. A European who thoroughly understands his business, and who is able to impart his knowledge and his instructions in a clear manner to his Chinese subordinate, and who, moreover, is blessed with a little patience and tact, will find little difficulty in the management and control of Chinese labor of whatever kind. Speaking generally, they are good and conscientious workmen, and many indeed are very clever fellows. The quality of the work turned out by a good Chinese fitter, turner, or machine man varies little from that of the average good British workman of the same class, but the latter would beat him in point of time.—*The Engineer.*

# IMPROVED HANNA LOCOMOTIVE STOKER

Conveys the Coal from the Tender and Discharges Through the Fire Door with Original Distributing Device

The Hanna Locomotive Stoker was fully illustrated and described on page 121 of the April, 1911, issue of the American Engineer & Railroad Journal. That machine was arranged so that it was necessary for the fireman to shovel the coal from the tender to a hopper and the stoker simply delivered it to the firebox and distributed it over the grate area. A number of machines of this kind were applied and successfully operated for some time, but owing to the requirement of shoveling the coal by hand, it did not receive an extensive application. One of the original stokers, however, which was fitted to a large Mallet locomotive on the Carolina, Clinchfield & Ohio, has remained in operation during the past three years and has successfully fired this large locomotive during that time.

The Hanna Locomotive Stoker Company, Mercantile Library Bldg., Cincinnati, Ohio, realizing the necessity of having the stoker convey the coal from the tender as well as to distribute it in the firebox, proceeded to redesign its machine to accomplish this object. The improved stoker maintains the original construction, arrangement and operation so far as the distribution of the coal after it reaches the fire door is concerned. In other

locomotive tested was a 2-6-6-2 type having a total weight of 342,650 lb. The cylinders were 23 in. and 35 in. by 32 in. stroke and the engine has 57 in. drivers. It carries a steam pressure of 200 lb. and develops a tractive effort of 70,640 lb. A 6 in. diameter exhaust nozzle was in use.

In the test without the brick arch over a .5 per cent grade, trains of about 3500 tons were drawn. The average speed in

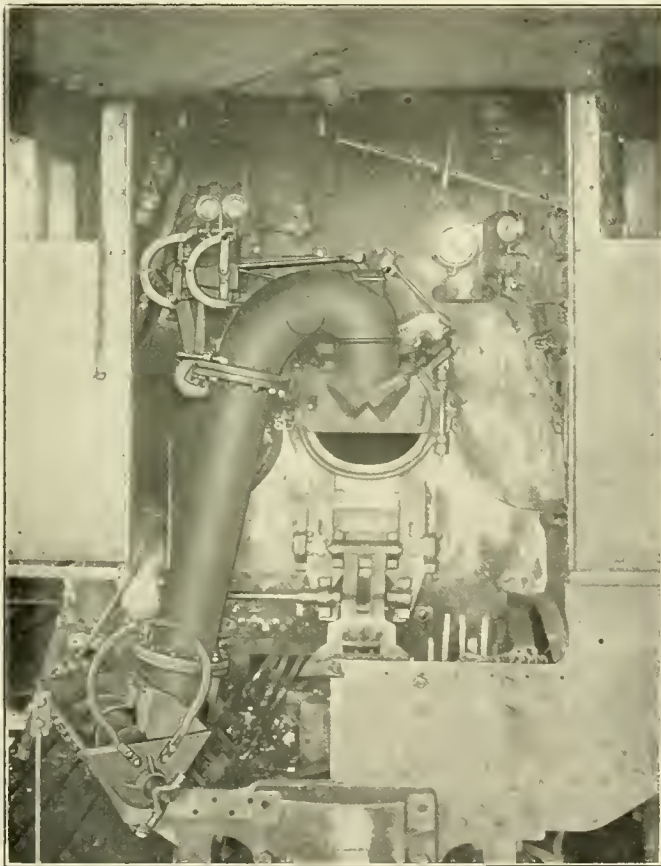

Hanna Stoker with Tender and Cab Deck Removed

respects, however, it has been altered as is shown in the accompanying illustrations.

One of the new machines was applied to a Mallet locomotive on the Carolina, Clinchfield & Ohio and has been in regular service for a number of months. A preliminary test was made with this locomotive to ascertain the advantage in connection with fuel economy of using a stoker fired engine as compared with hand firing, both with and without the brick arch. The

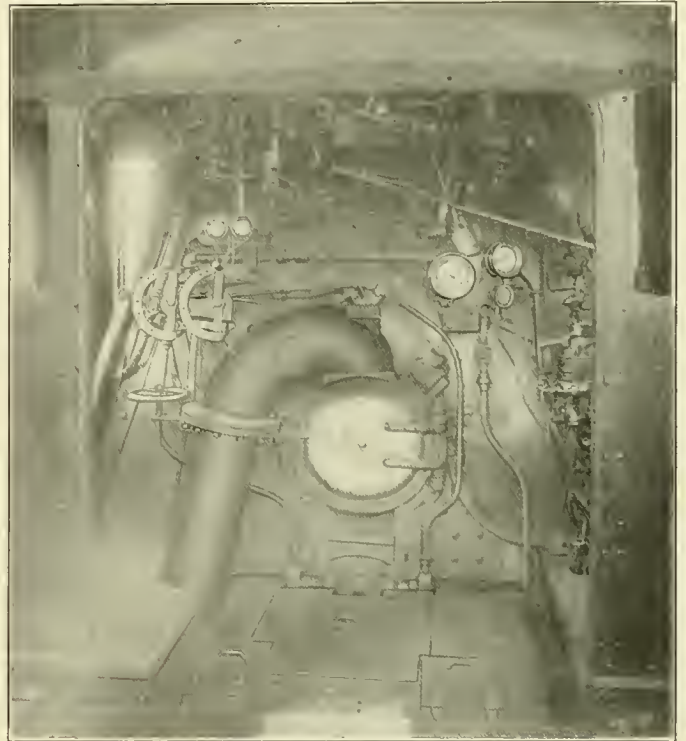

Cab of a Locomotive Equipped with a Hanna Stoker

miles per hour for the hand fired was 8.44 and for the stoker fired 7.4. The most interesting figure of the test was the total evaporation per pound of coal from and at 212 deg.; this for the hand fired was 7.95 lb. and for the stoker fired was 8.54 lb., an increase of .56 lb. or 7.39 per cent. Similar tests with the brick arch gave an equivalent evaporation for hand firing of 8.94 lb. and for stoker firing of 9.52 lb. This is an increase in favor of the stoker of 6.72 per cent.

In the new design of stoker there is a small vertical, two cylinder, reversible steam engine located on the tender and placed on the right side in the space usually occupied by tools. The flat portion of the coal space is replaced by a conical hopper, at the bottom of which is the screw conveyor. This allows all of the coal in the tender to feed to the conveyor by gravity. In the illustrations this hopper is shown as covered with removable strips but in practice they were found to be unnecessary and have been removed.

The steam engine drives the conveyor through a clutch and bevel gears to a shaft which extends diagonally across under the tender deck and parallel to the screw conveyor. This shaft connects to the conveyor on the tender by means of spur gears at the back end. The tender conveyor partially crushes the coal against knives located at the outlet from the hopper and carries it forward toward the left side of the locomotive to a point above the end sill of the tender frame. Here there is a ball and socket joint and a sheet iron pipe through which the



coal is crowded and falls to the hopper of the feeding conveyer.

At the forward end of the shaft which drives the tender conveyer there is a universal joint and it continues and drives a short section of spiral conveyer which is arranged with left hand spirals on either side of a cover plate that is directly opposite the opening to the vertical conveyer. This short section of conveyer is employed for the purpose of feeding the vertical. An extension of the shaft beyond the feeding hopper, through a double sprocket wheel and short sections of chain, conveys the power to a shaft underneath which in turn drives the vertical conveyer by a bevel gear.

The vertical conveyer is enclosed in the cast iron pipe shown in the illustration which passes through the cab deck on the left hand side and close to the boiler head. At the top of this pipe is a short elbow section and the coal is forced through this by the pressure from behind and falls into the distributing apparatus by gravity.

The section of the stoker carrying the distributing wings is arranged to latch to a swinging ring hinged on the regular fire door pin, allowing this to be swung open for observation, hooking or even hand firing as though it was a regular swinging door, while at the same time automatically disconnecting or connecting the wing controlling mechanism through a slot and pin. If it is

the left does not in any way interfere with the work of hand firing.

The distributing apparatus is unique and consists of two sets of jets, there being seven arranged in an arc, each being at the end of a cast iron finger. Below these is a very thin narrow opening through which a flat jet of steam emerges. Above these jets is a ridge plate slanting downward and on either side of this are wings swung from hinged connections arranged perpen-

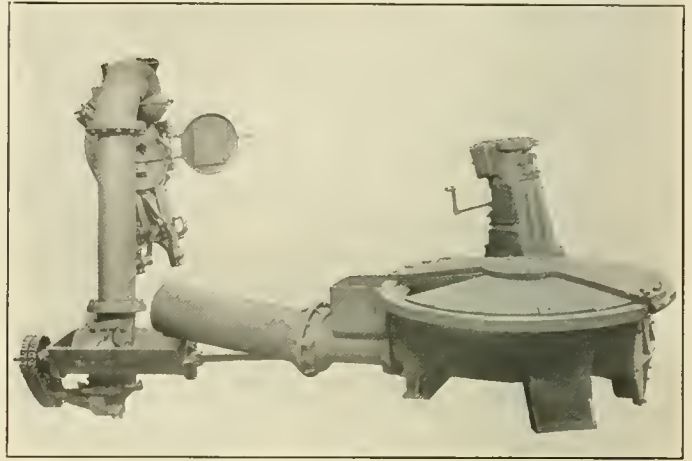

Hanna Locomotive Stoker; This View Does Not Show the Distribution Control Levers

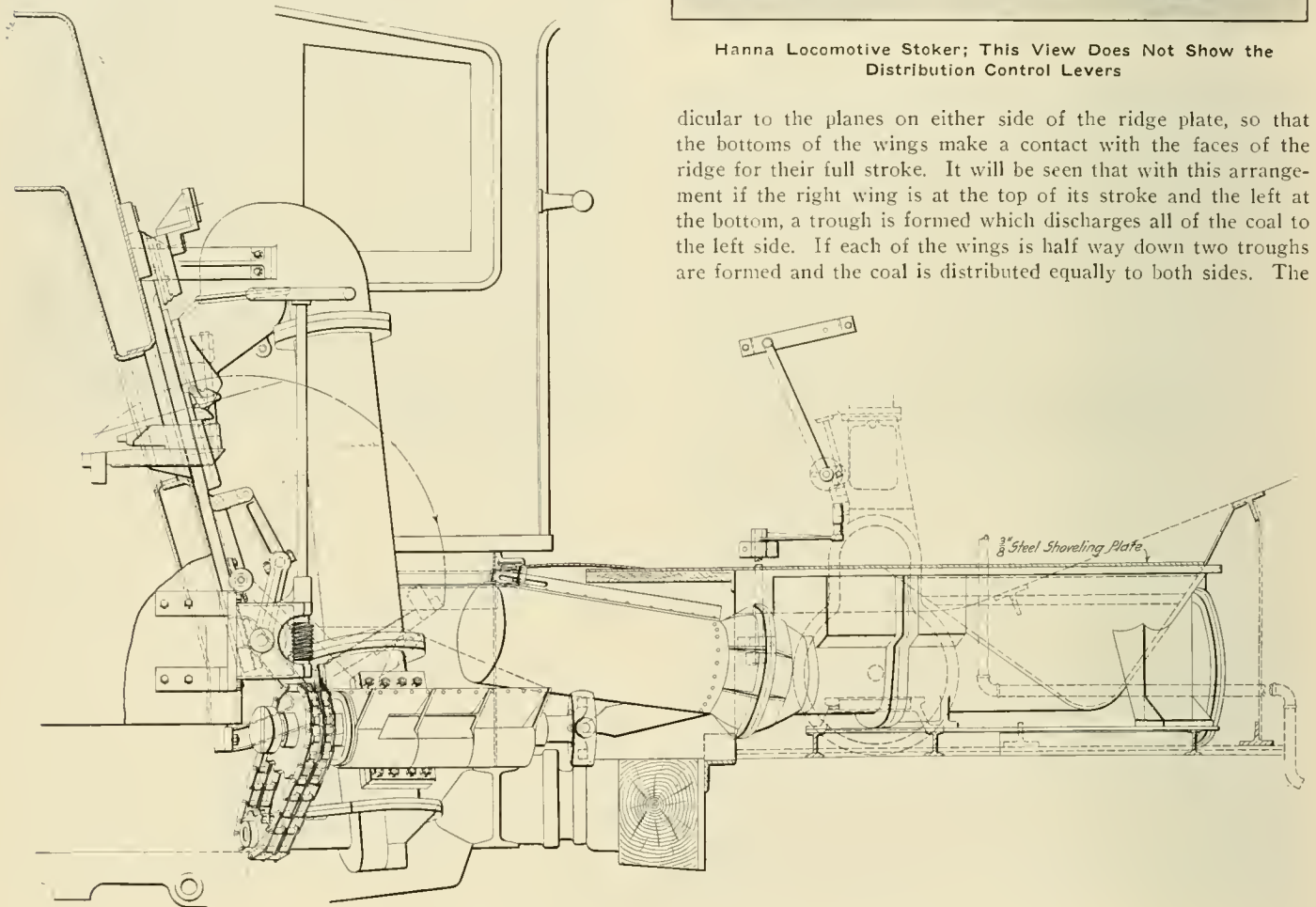

Complete Hanna Stoker in Position on a Locomotive

desired to have the full opening of the fire door for any purpose, this wing section can instantly be detached from the ring and laid aside by one man and the section of the distributing apparatus which contains the steam jets is arranged to swing beneath the deck by an operating wheel in the cab. The deck opening is covered by a sheet iron plate. This allows the regular fire door, which is in place on the right hand side, to be closed against the ring and used in the ordinary manner. The pipe coming up at

dicular to the planes on either side of the ridge plate, so that the bottoms of the wings make a contact with the faces of the ridge for their full stroke. It will be seen that with this arrangement if the right wing is at the top of its stroke and the left at the bottom, a trough is formed which discharges all of the coal to the left side. If each of the wings is half way down two troughs are formed and the coal is distributed equally to both sides. The

coal, after passing into these troughs is dropped in front of the steam jets and the fine particles will pass between the fingers and be caught by the flat jets below. This is normally maintained at about 20 lb. less pressure than the jets emerging from the fingers and the fine dust is thus discharged to the firebox underneath a stronger jet, which tends to hold it down until it is consumed. The larger pieces, however, strike the fingers and are caught by the jets at the ends and the pieces are thus blown

to various parts of the firebox, depending on the direction of the jet which catches each. The distribution is thus controlled by the wings, which are very ingeniously operated and will permit a definite amount of coal to be fed to different parts of the firebox continuously.

The adjusting levers for these wings are shown at the left side in the view of the interior of the cab. By moving the handles along the arc, the travel of the wings on either side of the ridge plate is controlled and these wings can be made to continuously follow any determined path. If, for instance, it is found that the locomotive is burning stronger on the right side than on the left, the right hand wing will be arranged to travel from the bottom of its stroke two-thirds of the way up and back again while the left hand wing will be arranged to travel from a point two-thirds down, to the top and back. In this way a greater proportion of the coal will be distributed on the right hand side and a smaller proportion on the left. This adjustment, together with the control of the pressure of the steam in the

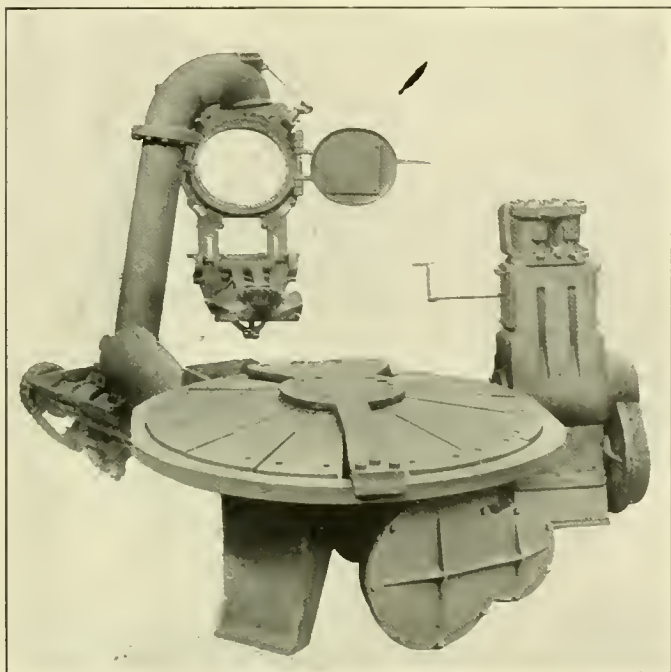

Hanna Stoker Ready for Hand Firing

jets, allows great flexibility and it is possible to so adjust them as to suit the burning conditions of any locomotive.

The capacity of this machine for firing depends altogether on the speed at which it is operated.

At the present time a Hanna stoker of this type is also in operation on a 12-wheel locomotive on the Norfolk & Western and the preliminary runs are reported as being very successful.

**KANSAS FUELS.**—The fuels of Kansas include coal, petroleum and natural gas. The coal mining industry has been an important one for the past 40 years, and at present furnishes employment for about 13,000 men. The amount mined in this period is 2.2 per cent. of the total known deposit, and at the average rate of the past five years it will take 762 years to exhaust the supply.

**STANDARDIZATION.**—Extension of the practice of standardizing many parts of the locomotive, particularly those requiring frequent repairs or renewal, is general. Even the practice of standardizing whole locomotives so as to greatly reduce the number of classes in service, with an accompanying large improvement in the maintenance account and in the conditions of operation, is found on the more progressive roads.—*Railway Age Gazette.*

## LENOX SERPENTINE SHEAR

The new type of shear shown in the illustration has been perfected by the Lenox Machine Company, Chicago, Ill., and is designed particularly for the straight and irregular cutting of sheets and plates.

The frame is a steel casting of spiral construction designed to provide sufficient clearance for material of unlimited length or width. It will not only allow straight cutting, but also in or out curves having a minimum radius only slightly larger than the diameter of the blades. The spiral steel frame carries all gearing and is mounted on a cast iron base.

The blades are made of high grade tool steel, and are set in approximately a horizontal plane. This gives a very large

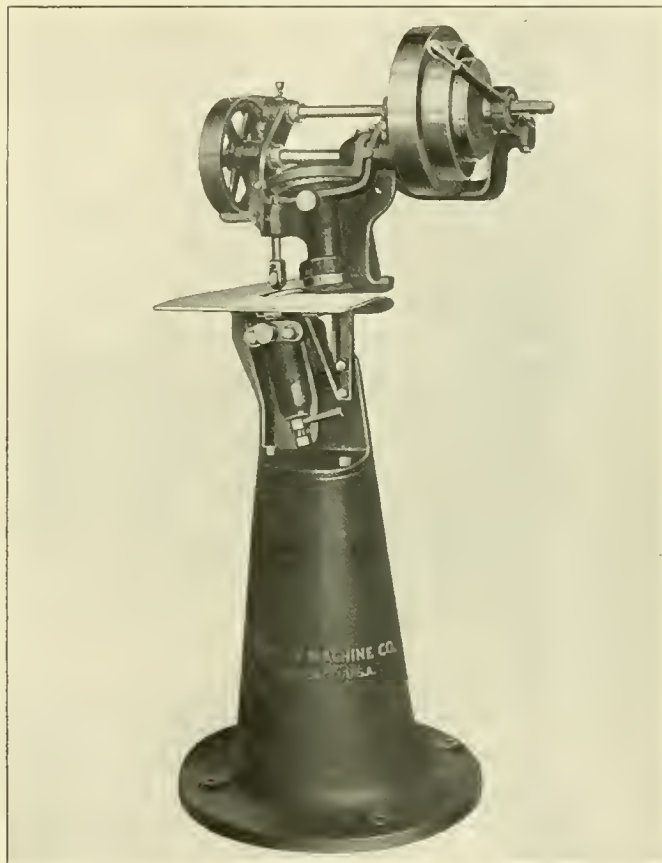

A New Serpentine Shear

cutter bearing on the sheet or plate, and consequently, there is very little distortion in the cutting. The upper cutter is positively driven, while the lower is mounted in an adjustable sleeve, so that its position may be varied to allow for different thicknesses of material and for redressing. In addition, a cam is provided so that the lower blade can be dropped enough to permit the removal of sheets without reversing the machine. The cutters have a flush fastening to the shaft and no nut projects to interfere with the handling of the work. The knurled edges feed the sheet automatically into the machine. A tool steel pin is provided to take up the end thrust on the lower cutter shaft.

Where a number of sheets are to be cut to the same pattern, a template may be bolted to the work and this template followed by guiding against the top cutter.

The machine is driven by a two-speed pulley, giving slow speed for intricate curve cutting and high speed for straight work. The main drive shaft is extended and squared on one end so that a hand crank may be used if necessary.

The shear illustrated has a capacity for cutting No. 10 gage



material and lighter, while other sizes having capacities of No. 16 gage,  $\frac{1}{4}$  in. and  $\frac{3}{8}$  in. material can be furnished. All machines are arranged for either belt and hand power or direct motor drive.

Joseph T. Ryerson & Son, Chicago, are the selling agents for the company.

### MUD RING AND TUBE SHEET DRILL

A four-spindled drill designed by the Foote-Burt Company, Cleveland, Ohio, for use in boiler shops was illustrated on page 619 of the November, 1913, issue of this journal. In this machine the four independent heads were mounted in pairs on auxiliary cross rails which allowed the drills to reach a minimum center distance of 8 in. in each pair.

A somewhat more elaborate machine has been installed in the Juniata shops of the Pennsylvania by the same company and is shown in the illustration. It is used principally for drilling the rivet holes around the firebox mud ring, and tube holes in the

of continuous box section and the table is arranged with T slots and fitted with removable mud ring chucks, the same as in the smaller machine. It also has an in and out motion of 36 in. controlled by a lever at either end of the machine.

This drill is motor driven. A Westinghouse 20 h. p. motor with speed adjustment from 375 to 1,500 r. p. m. is geared direct to the driving shaft by a large spur gear and a rawhide pinion, both of which are guarded. The weight of the machine is 23,000 lbs.

### CROSS COMPOUND AIR COMPRESSOR FOR THE LACKAWANNA

The Delaware, Lackawanna & Western has installed at its Kiser Valley shops at Scranton, Pa., a new class M-CSC two-stage compressor recently placed on the market by the Chicago Pneumatic Tool Company, Chicago. This compressor has steam cylinders 19 in. and 31 in. by 26 in. The air cylinders are 28 in.

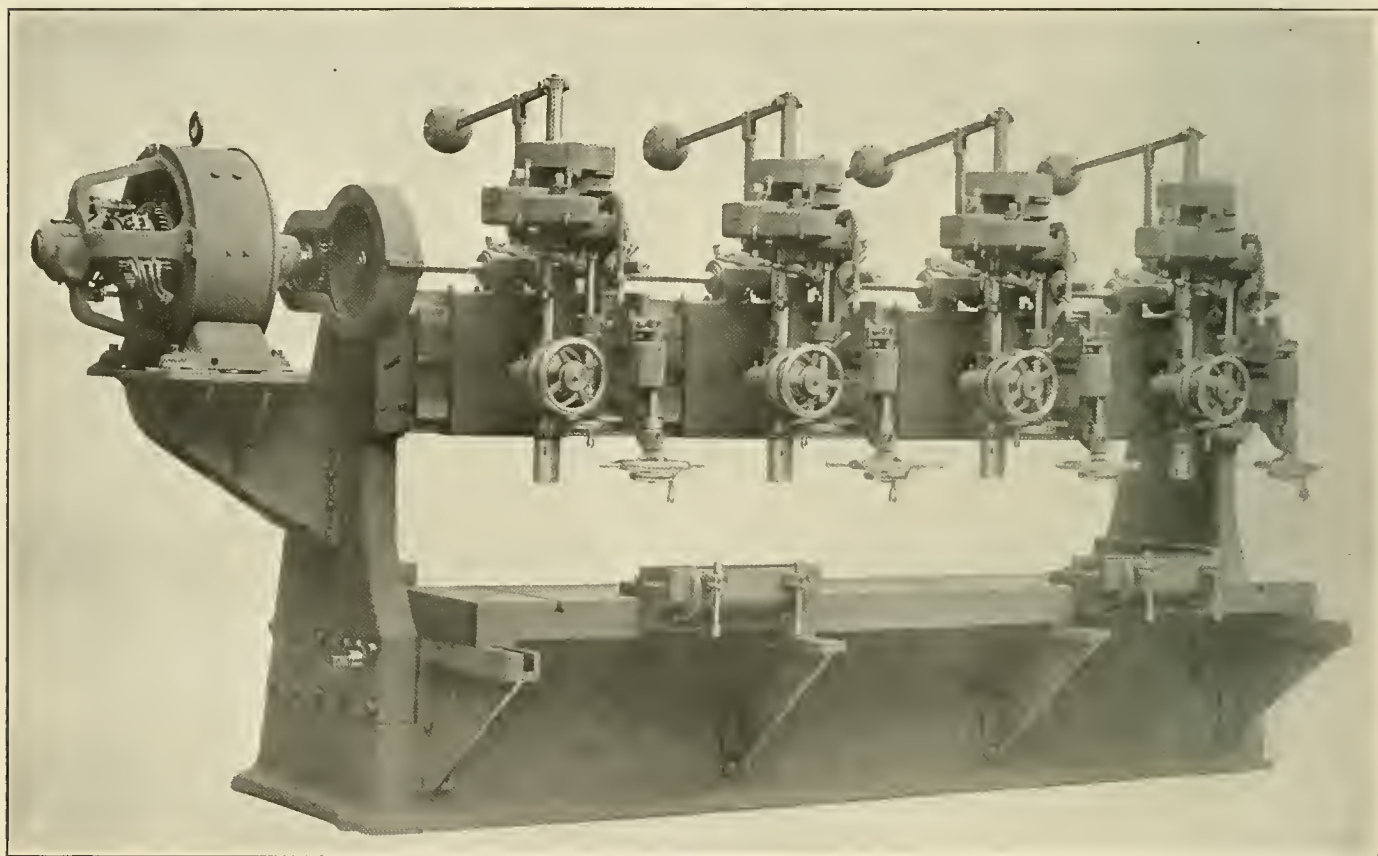

Four Spindle Drill for Mud Rings and Tube Sheets

boiler tube sheets. The four heads of the machine are entirely independent of each other and are arranged to have an in and out adjustment from the main cross rail for a distance of 12 in. They are also adjustable on the main cross rail up to a minimum center distance of 18 in. Both of these adjustments are controlled by the individual hand wheels shown in front of each slide.

The heads carrying the spindles are complete in themselves, as each is arranged with a clutch for stopping and starting. Each is fitted with geared power feed with adjustable stop for automatically stopping it at any desired point. Two changes of power feed are provided on each head, either one of which is available by shifting a conveniently located lever. In addition to the power feed, each spindle is furnished with a hand feed through a worm gearing.

The main rail is very heavy and of box form. The base is

and 17 in. The compressor is rated at 2,500 cu. ft. of free air per minute at 135 r. p. m., which is the maximum speed for which the air and steam valves and ports are designed. The steam and exhaust valves are of the Corliss type, being operated by a simple system of links connected to wrist plates, which in turn are driven by eccentrics on the crank shaft.

The chief feature of this machine is its economical operation from a fuel standpoint. It has a lower steam consumption than a machine of the cross-compound type with the Meyer gear. It is interesting to note that a railroad in the position of the Lackawanna, located as it is in the coal district, finds it practical to purchase a compressor of low steam consumption in an endeavor to save fuel.

The frames of this compressor are of the full Tangye type, having a box case which is fully enclosed. The main bearing and guide barrel are cast in a single piece extending to the founda-

tion. The air cylinders are bolted directly to the frame with the steam cylinders behind and in line with them. They are held in alinement by two heavy tie rods and are further anchored to box-shaped sole plates extending under the steam and compressor cylinders. The foundation bolts secure the main frame and the sole plates only, the cylinders resting on the finished faces of the sole plates to which they are secured by heavy bolts. This arrangement will permit any of the cylinders being

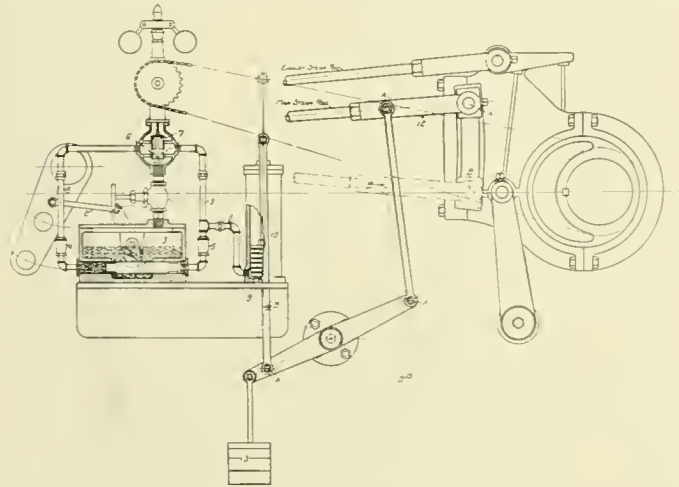

Speed Governor and Speed Regulator for Cross Compound Air Compressor

removed and returned to correct alinement without disturbing the frame.

The frame and guides are enclosed, which permits of complete flood lubrication for all main bearing points. Both the steam and air cylinders are made large enough to ensure two reborings with perfect safety. The air valves in the cylinder head are so located as to be easily accessible for examination or renewal. The inlet valves are placed at the bottom of the cylinder head and are of the Corliss oscillating or rolling type, with unusually

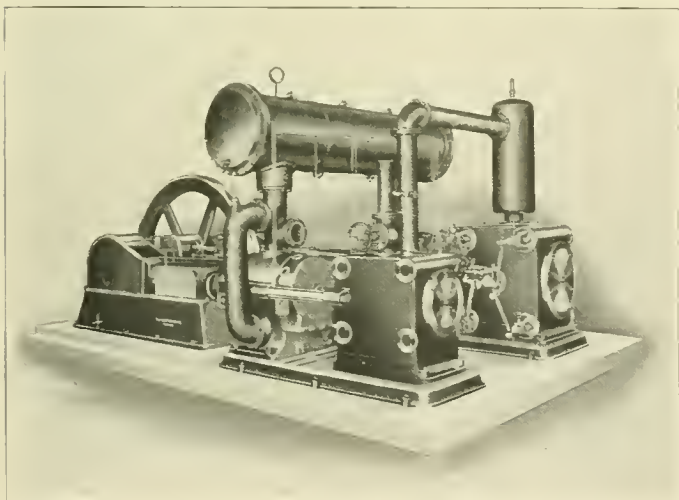

Cross Compound Air Compressor for the Lackawanna

large port openings and small clearance with consequently free direct inflow of air. The discharge valves are of the mushroom type. The steam valves are of the Corliss oscillating type. The exhaust admission valves operate independently of each other. The exhaust valves have a fixed opening and the steam valves are regulated according to the speed and load requirements.

One of the most interesting features in the design of this machine is the speed governor and pressure regulator. As

shown in the illustration, the high and low pressure valve gears are each operated by one eccentric, the rods being connected to different points on the eccentric straps, thus giving independent drives to the valves. The high pressure steam gear, working in a link, has an adjustable setting; *A* and *B* show the maximum and minimum cut-off points. The position of this rod is controlled by the governor which operates as follows: A positively operated plunger pump driven by the air rocker arm and a lever *2*, pumps oil from the reservoir *3*, through the check valves *4* and *5* into the chamber *6*, through the valve *7*, and again to the reservoir *3*. The position of the valve *7* is controlled for speed by centrifugal force, and for pressure by a pressure cylinder, similar to the regular speed and pressure governor. An increase in the speed or air pressure gradually closes the valve *7*, causing the oil pressure in the pipes *8* to rise. This increase of oil pressure raises the plunger against the weight *13*, changing the position of the link *12* from position *A*, in the direction as shown by position *B*, thus reducing the point of cutoff. When the air pressure drops, the valve *7* opens, reducing the oil pressure in the cylinder *10*, allowing the weight *13* to drop and increase the point of cut-off in the direction as indicated by *A*. Valve *11* is for adjusting the amount of oil opening for the maximum speed of the machine.

### VARIABLE SPEED AND REVERSING ATTACHMENT

An attachment for drill presses which provides three speeds and a reverse for the drill without change in the adjustment of the drill press, is shown in the accompanying illustration. These

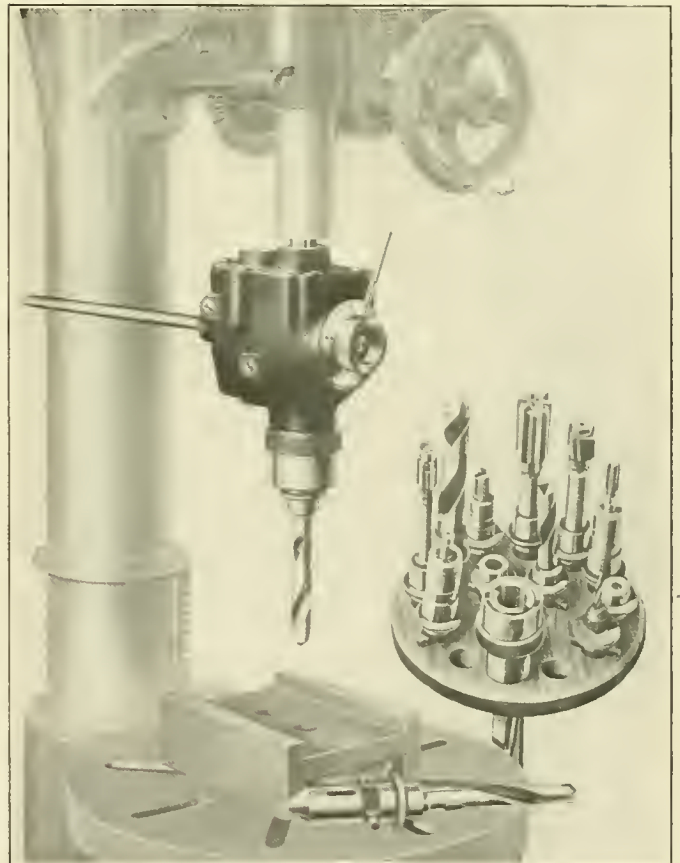

Variable Speed and Reversing Attachment for Drilling

changes of speed or reversing are made without stopping the machine and provide for the convenient use of different sizes of drills and taps in the same hole or in the same vicinity. This attachment is carefully built of high grade materials. There



are no sliding gears and the transmission is effected by two hardened and positive-acting clutches. All the gears are of hardened steel and the loose gears run on phosphor-bronze bushings. The direct speed is the same as the spindle speed, the intermediate speed is about two and one-half times faster than the direct and the high speed is about five times faster.

This attachment, as ordinarily furnished, includes a Wizard chuck which permits the changing of all sizes and kinds of tools without stopping the machine, but it can also be obtained with a No. 3 Morse taper hole or a stub arbor so that any other style of chuck can be used if desired. It is built by the McCrosky Reamer Company, Meadville, Pa.

## CINCINNATI CYLINDER PLANER

On page 102 of the February, 1914, issue of this journal there appeared a description of an 84 in. planer designed by the Cincinnati Planer Company, Cincinnati, Ohio, which included a number of new and original features.

The same company has also perfected a machine which is specially adapted for planing locomotive cylinders. This is made in a 72 in. by 72 in. size and contains all the improvements and conveniences of the 84 in. machine previously illustrated. It has rapid power traverse to all heads in any direction, and all movements are independent of each other and can be made whether the table is in motion or not. Reference can be made to the previous description for the

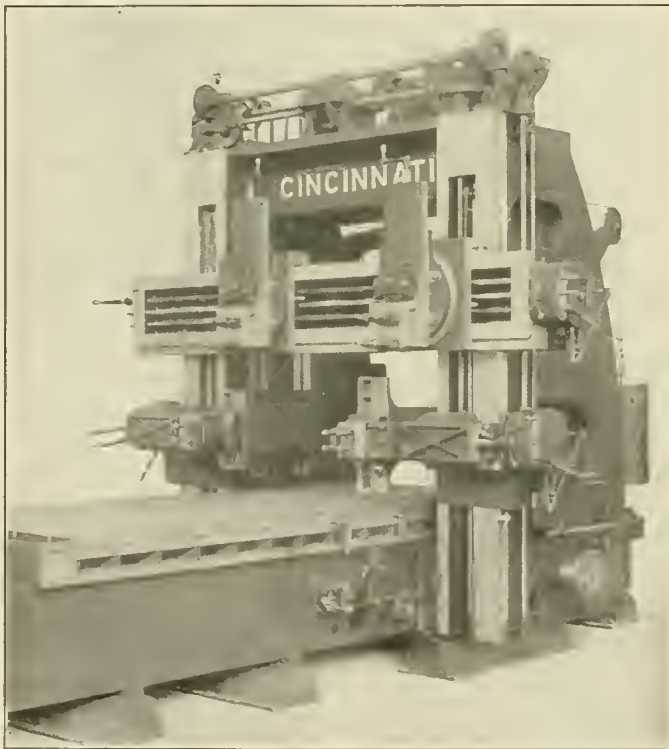

Cylinder Planer with Rigid Side Heads

arrangement of the parts and the other features of special interest.

The specially added feature in the cylinder planer is the extra side head supports which take the form of brackets rigidly bolted on the inside of the housing, and which support the side cutting heads while planing the frame fits, etc., on cylinders. These brackets are adjustable in height and can be used in any position between the top of the table and the bottom of the cross rail. A sliding shoe fits the front face of these brackets and has a dovetail support for the cross slide on the side heads. This construction eliminates all

twisting strains on the housing face usually caused by the long overhung slide and the upward pressure of the tool. These brackets can be easily removed from the machine, thus converting it to a standard planer.

## BORING AND TURNING MILL

The Niles-Bement-Pond Company, 111 Broadway, New York, has recently re-designed its Niles boring and turning mill. The new machine has centralized control, all changes of speed and reversal being within reach from the operator's position. One lever disengages the feed, engages the fine and coarse feeds and

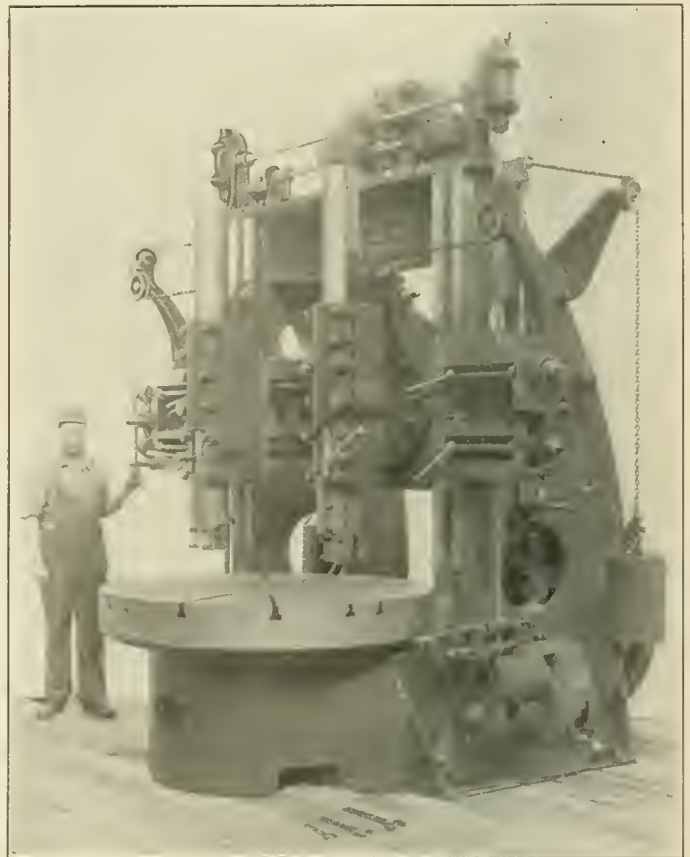

Improved Design of Niles Boring and Turning Mill

operates the fast traverse in either direction. Power reverse traverse to saddles and bars in either direction is provided. The hand adjustment of saddles and bars is by automatic releasing ratchets located at the sides of the saddles. No part of the machine extends below the floor line and no special foundation is required. The housings are of box girder form, double webbed and without openings in the front face, the cross rail elevating screws being located between the housings. They are securely bolted to the bed and tied together at the top by a heavy brace. The table is deep and strongly ribbed and is supported by an annular bearing of large diameter running in a bath of oil. The cross rail is of the three track type, having a narrow guide at the bottom with the saddle traversing screw located between the guiding surfaces. Power adjustment is provided. The saddles have wide bearings on the cross rail with provision for taking up wear by means of taper gibs. A clamp bolt is provided for clamping each saddle when the bar is feeding.

The feeds are eight in number, are positive, continuous and reversible. They are independent for each head, both in amount and direction for down, cross and angular feeding. The counterweights for each bar are attached to the same chain, but act independently. The counterweight chain is placed at the rear of the

bars to prevent interference from overhead cranes when handling work on and off the table. Safety friction clutches located on the vertical spline shafts insure against accidents, in case the heads or bars meet with obstruction when either feeding or fast traversing. All shafts are of high grade steel and the drive is bushed throughout with bronze. Taper gibs are used to take up the wear on sliding surfaces. All driving, feeding, fast traversing and elevating gears are of liberal diameters.

The motor drive by direct current is by a motor of 4 to 1 speed variation, carried on a drive plate in the rear between the housings. Power is transmitted through a double run of clutch gears, giving two mechanical changes in speed, which, with the usual 16 or more speeds in the controller gives 32 or more speeds to the table. The motor is fitted with push-button control and a dynamic brake for the table. A separate motor, located on the top brace of the mill, is furnished for elevating the cross rail and providing rapid power traverse to bars and saddles. Belt drive through a single pulley or alternating current motor drive by constant speed motor is provided through a speed box and back gear located in the rear of the mill, giving 12 changes of speed. The belt driven machines are built on the convertible plan, and may be readily changed to motor drive.

These machines are built in 44, 53, 62 and 73 in. sizes, the horse power of the motors required ranging from 7.5 to 12.5.

### STANDARD 48 INCH PLANER

The accompanying illustration shows the latest development of standard double housing type planer built by the Detrick & Harvey Machine Company, Baltimore, Md. This machine is a very rigid type of straightforward planer which measures 50 in. between the housings and 50 in. between the table and the crossrail when it is at the highest position. The reciprocating motion of the table is obtained through the medium of a spur gear.

The bed of the machine is of the two V-way type with a

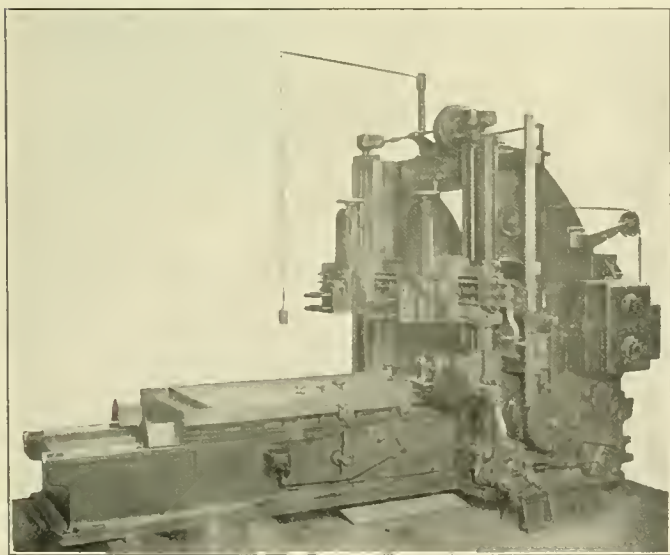

Detrick and Harvey Standard Planer

closed top. There is an opening in the top of the bed to allow the gears to be placed in the machine or taken therefrom while on the foundation, but the metal extends under and around the gearing so that it may run in oil. The centers of the V-ways are 26 in. apart and the width across the top of each V is 5½ in. The included angle of the ways is 110 deg.

A box type table with a continuous bottom plate is supplied. It is 40 in. wide and 10 in. in depth over the ways. The table rack is semi-steel, cut from a solid bar and bolted and keyed to the table. The width of the rack is 7 in.

The crossrail has a vertical face of 16¼ in., a depth of 7 in. opposite the housings and is 16 in. in depth between the housings. The power movement of the crossrail is through a frictional device. On the crossrail there are two cutter heads with the tool posts slightly offset so as to bring them close together. The tool slides have a vertical adjustment of 16 in. by hand and an automatic power feed in all directions. There are two side tool heads which have independent automatic power feeds vertically in either direction and hand adjustments on the housings.

A positive friction type feed mechanism is employed and it has sufficient power for feeding the four heads simultaneously. It is designed to slip under undue strain and to consume power only while feeding.

The illustration shows the operating side of the machine and the motor is mounted on the floor on the opposite side. The machine shown in the illustration has a reversing type motor drive. It will be seen that the control switch for starting and stopping the motor is carried to a convenient point over the center bed from an overhanging conduit.

### HYDRAULIC SHAFT STRAIGHTENER

A hydraulic press that has a capacity of 325 tons, which is sufficient for taking the bends out of any steel shaft up to 10 in. in diameter, has recently been produced by the Watson-Stillman Company, 50 Church street, New York City. The length of the shaft is limited only by the extent of the foundation provided.

This is a motor driven self contained unit, requiring no outside air or hydraulic system. There are three independent parts;

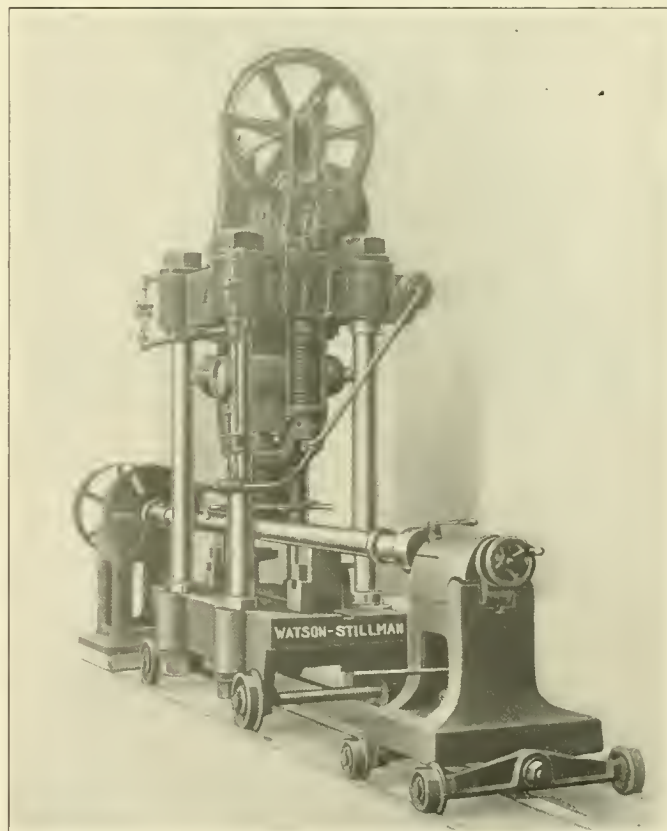

Shaft Straightener Showing Supports for the Ends of the Shaft

the head stock which is stationary, and the press and tail stock, which are on rollers to permit their adjustment to varying lengths of shafts. The bed rails are flush with the floor so that when not in use the movable parts can be rolled to one side, leaving the floor clear of obstructions. The head and tail stocks are similar to those of a lathe, except that the centers



are hinged to follow the movement of the shaft ends when the bend is made. The shaft is revolved from the head stock and the "high point" marked. The press is then moved to that point and the bending blocks adjusted.

The ram has a maximum movement of two inches, the return movement being effected by springs. Screwed concentrically into the ram is a square threaded adjustment screw, which compensates for the different diameters of the shafts and also enables the operator to predetermine the flexure desired. This eliminates all danger of overbending.

The entire hydraulic power plant, including five-horsepower

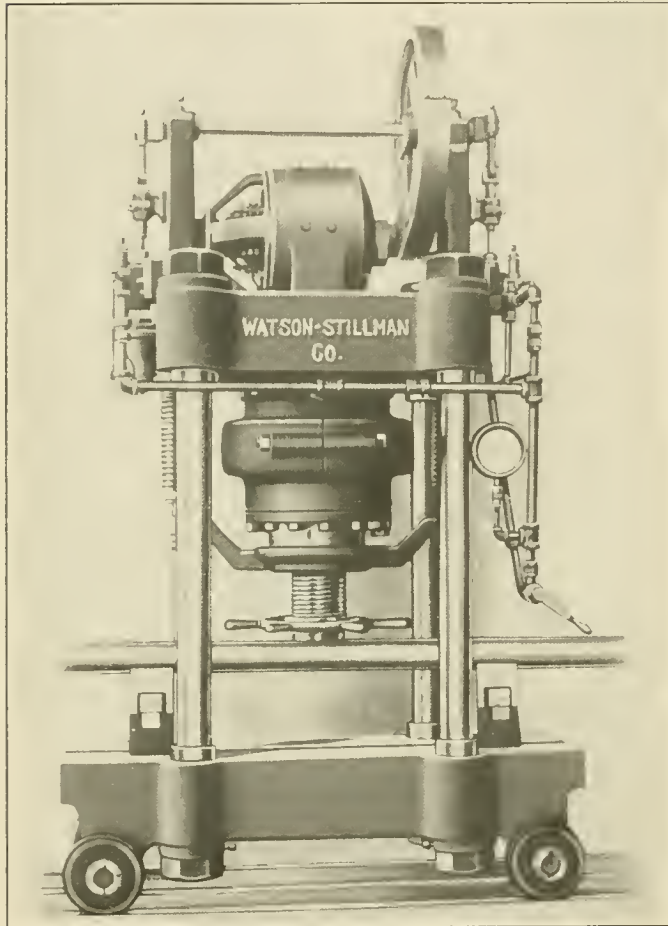

A Closer View of the Shaft Straightener

motor, pump, reservoir, etc., is mounted on the top platen of the press. The floor space required is 3 ft. 6 in. wide by the length of the shaft, plus 6 ft. The total net weight of the press is 19,300 lb.

**CANADIAN WIRELESS.**—When the new chain of wireless stations, now in course of construction by the Canadian government, is finished and in operation it will be possible for a passenger on any incoming steamship to communicate from mid-ocean as far inland as Fort William, Ont.

**CIRCULATION IN REFRIGERATOR CARS.**—Not only must a refrigerator car be well built and well insulated, but the icing arrangement must be such that the cold air will be well circulated throughout the car. Proper circulation will not only keep the contents of the car at a uniform temperature, but will also carry away the moisture given off by the contents, which, of course, is necessary for the protection of the contents, especially fruit and vegetables. When these products are loaded in a refrigerator car without any precooling it is usually advisable to ventilate the car to the first icing station in order to eliminate the moisture given off by the warm products.—*Railway Age Gazette.*

## FIRE EXTINGUISHER

The illustrations show a portable fire extinguisher which is adapted for use in railway service. These extinguishers are made of steel and are charged with a chemical consisting of a calcium chloride solution filled to a height shown in the drawing as the liquid line. Compressed air is then applied through the special Schrader air valve, the air passing down through the brass tube which extends below the liquid line and provides a liquid seal to the air valve. To operate, the horn shaped lead nozzle at the bottom of the tank is broken off, the shield first being raised. This makes a clean cut opening into the tank and the air pressure will force the liquid out for a distance of 25 ft.

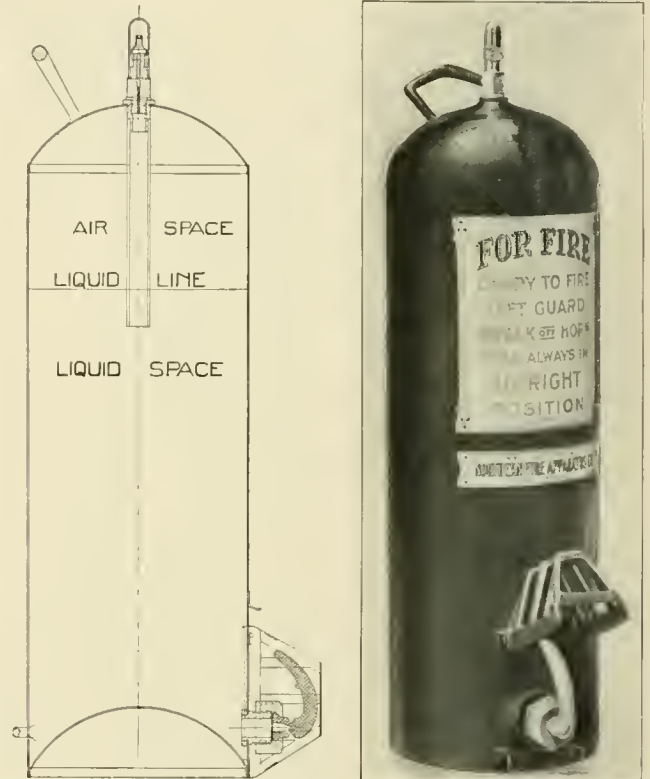

Fire Extinguisher Operated by Air Pressure

To fill the tank the liquid is poured through the spug at the bottom and a new lead nozzle is applied. The compressed air is pumped in through the valve at the top, a gage being used to determine the correct amount of pressure. The air may be pumped in with a standard tire pump. This air valve also permits of frequently testing the air pressure by means of a standard tire tester. If any leak should occur in the air valve and thereby reduce the required pressure the liquid would be forced up through the valve, clearly indicating that it was not properly seated. The lead horn is protected by the nozzle guard, which is shown raised in the photograph. This extinguisher is made by the Northern Fire Apparatus Company, Minneapolis, Minn.

**PASSENGER COACHES IN SWEDEN.**—There appears to have been considerable development in the Swedish coach in recent years. The new models are much longer and heavier than the old four wheel type, and the swiveled truck is coming into general use. The compartment prevails, but a corridor is run along the inside of the coach at one side. Sleeping cars are arranged in the same way. Vestibuled coaches are run through from the Continent, but cannot be said to be in general use in Sweden. Gas is generally used for lighting and steam for heating in the better class of equipment.—*The Engineer.*

# NEWS DEPARTMENT

The paint and coach shops of the Wabash at Moberly, Mo., and ten coaches were destroyed by fire on March 9.

The Illinois Central has taken out a building permit for a hospital at Fifty-eighth street and Stony Island avenue, Chicago, to cost \$400,000.

On the Delaware, Lackawanna & Western in 1913, the weight of mails carried exceeded by 23 per cent the quantity carried in 1912, while the increase in compensation received was only 6.19 per cent.

At Bakersfield, Cal., March 16, Maurice Rice, 17 years old, rode a mile on a motorcycle in 51 seconds, doing the feat on a dirt track. On the same track Rice has ridden his machine 67 miles in one hour.

On the Chicago & North Western at Manlius, Ill., March 13, robbers who tried to steal freight from a train standing near the station, shot and killed the engineman and wounded two deputy sheriffs; and one of the robbers was killed.

The Gulf, Colorado & Santa Fe has ordered a hospital car costing \$10,000, which will be kept at Cleburne, Tex. The car is to be fitted up with an operating room and equipped to take care of from fifteen to twenty patients at one time.

The mail car of train No. 11 on the Southern Railway was robbed on the night of March 5, near Columbia, S. C. The robber intimidated the mail clerk with a pistol, secured a number of sacks of registered mail and jumped off the train.

The Superior Court at Bridgeport, Conn., has sustained the plea of ex-President Mellen's counsel that the indictment of Mr. Mellen for manslaughter in connection with the derailment at Westport in 1912 is defective, but the state's attorney will now file an amended complaint.

The New York Central has applied to the New York State Public Service Commission, Second district, for relief from the law which requires it to use oil fuel in locomotives in the Adirondack forest preserves. Operating expenses were increased, in one year, by the use of oil, in the sum of \$106,201. The road declares that with suitable precautionary measures it will be safe to use coal.

The Pennsylvania has decided to lay wires underground between New York and Philadelphia, 90 miles, and the directors have authorized the immediate commencement of the work on the 25-mile stretch between Trenton and Rahway, appropriating \$300,000 for this purpose. By the storm of March 1, all the company's electrical communication was suspended between New York and Philadelphia more than two days.

H. C. Nutt, chairman of the central safety and efficiency committee of the San Pedro, Los Angeles & Salt Lake, announces a 50 per cent reduction in the number of personal injuries to employees in January as compared with December, and also a reduction of over 50 per cent in the number of train accidents during January as compared with December. The safety first movement was started on this road on November 1. During the month of November there were 75 personal injuries to employees, in December 68 and in January only 34. Only one-half of the 34 were serious enough to be reported by telegraph.

## THE WESTINGHOUSE MEMORIAL ASSOCIATION

An organization has been formed at Pittsburgh, Pa., composed of the friends of the late George Westinghouse, with the purpose of erecting in that city a memorial of some kind to Mr.

Westinghouse. The president of the association is Col. H. G. Prout. It is proposed to open a popular subscription.

## A NEW INFORMATION BUREAU

The eastern railroads are to establish a bureau of information, with headquarters in New York City. The function of the bureau will be to make permanent the machinery for gathering, classifying and recording information such as was collected by the conference committee in connection with the recent arbitrations on employes' wages. John G. Walber, assistant to the third vice-president of the Baltimore & Ohio, and head of the efficiency, discipline and employment departments of that road, will have charge of the bureau, which will probably be started April 1.

## GOVERNMENT RAILROAD IN ALASKA

The Alaska Railway bill, providing for the construction of a thousand miles of railroad by the government and the expenditure of \$35,000,000, has been passed by both houses of Congress, the Senate having adopted recently the conference report already adopted by the House. President Wilson has already indicated his approval of the bill; and tentative plans for proceeding with the work of construction have been considered at the Interior Department. Secretary Lane, long an advocate of the project, is prepared to go ahead with it as soon as the President gives the word. The report of the conference committee appointed to settle differences between the two houses was adopted in the Senate by a vote of 42 to 27.

The measure authorizes the construction of not more than one thousand miles of railroad to connect Alaska's coal fields with the coast, the route to be selected by the President. He is to decide whether or not existing railroad lines in the territory shall be bought to be made a part of the government system, and whether the road is to be operated by the government or leased, after it is built.

The House eliminated from the bill a provision authorizing a bond issue of \$35,000,000 to finance the railroad and to be paid off by the proceeds of government land sales in Alaska, and under the amended measure the project will be financed out of the current funds in the treasury. Congress will have to appropriate each year the amount necessary for construction.

The bill provides for the construction of a road "not to exceed 1,000 miles, to be so located as to connect one or more of the open Pacific ocean harbors on the southern coast of Alaska with the navigable waters in the interior of Alaska, and with a coal field or fields yielding coal sufficient in quality and quantity for naval use, so as to best aid in the development of the agricultural and mineral or other resources of Alaska."

## LORD STRATHCONA'S BEQUEST TO YALE

The gift of \$500,000 to Yale University in the will of the late Lord Strathcona is made "as an expression of his appreciation of the benefits he gained from investments in the United States, particularly from the St. Paul, Minneapolis & Manitoba and the Great Northern railways." The will directs that the money shall be used for "the promotion of the modern sciences and for instruction in the practical questions arising from the application of scientific knowledge to the industrial, social and economical problems of the time, it being my special desire to have the said sum expended so far as in the opinion of my trustees may be deemed advisable for instruction in civil and mechanical engineering, with special reference to the construction, equipment and operation of [instrumentalities of] transportation of



passengers and freight, whether by land or water, and the financial and legislative questions involved." The university is empowered to equip buildings or to endow chairs for the promotion of these ends, and the giving of scholarships in the scientific or graduate department is provided for. In awarding these scholarships preference is to be given to persons who for two years or more have been creditably connected with the railway companies above named, as officer or employee, and to their children.

MEETINGS AND CONVENTIONS

*Chief Interchange Car Inspectors' and Car Foremen's Association.*—The annual convention of the Chief Interchange Car Inspectors' and Car Foremen's Association will be held at Cincinnati, Ohio, August 25, 26, 27, 1914.

*New Haven Railroad Club.*—This is the name of an organization recently started at New Haven, Conn., with the object of promoting railroad knowledge and encouraging social relations and acquaintance among the different departments of the New York, New Haven & Hartford. The first regular meeting, followed by a dinner, was held at the Railroad Young Men's Christian Association in New Haven, March 16. The membership thus far is made up of officers, chief clerks, assistant chief clerks and bureau foremen; but the constitution appears to be liberal, not excluding any class. The temporary president is T. M. Prentice. Permanent officers will be elected at a meeting to be held April 21.

*The June Conventions.*—The exhibit committee of the Railway Supply Manufacturers' Association, in planning for the June conventions, held a meeting in Pittsburgh a short time ago. At that time 85 per cent of the exhibit space was assigned, which compares very favorably with the record at the same time for previous years. There are now available a very few booths in Machinery Hall, and some space in the Machinery Hall extension and Exhibit Hall. Every year more or less disappointment is caused because late comers find all of the space assigned and are unable to exhibit. It is suggested that all those who wish to exhibit made immediate application; as applications are coming in now it will be only a short time before all of the space is taken.

*Railway Storekeepers' Association.*—At the eleventh annual convention of the Railway Storekeepers' Association, to be held at Washington, D. C., in the Hotel Raleigh, Monday, Tuesday and Wednesday, May 18, 19 and 20, 1914, papers will be read on the following regular subjects: Stores Department Expenses; How to Obtain the Greatest Efficiency from Employees in the Stores Department; Handling of Stationery, and Classification of Electric Railway Materials. There will be committee reports on Recommended Practices, Accounting, Piece Work, Standardization of Tinware, Stationery, Uniform Grading and Inspection of Lumber, Scrap Classification, Membership, Standard Buildings and Structures, Book of Standard Rules, and Marking of Couplers and Parts.

*New England Railroad Club.*—At its annual meeting and dinner on March 10, the New England Railroad Club elected the following officers: President, H. E. Astley, roadmaster, N. Y. N. H. & H.; vice-president, P. M. Hammett, superintendent of motive

power, Maine Central; secretary, William E. Cade, Jr.; treasurer, C. W. Sherburne, Boston; finance committee, H. E. Astley, B. M. Jones and F. A. Barbey; executive committee, H. E. Astley, P. M. Hammett, C. W. Sherburne, C. B. Breed, associate professor, M. I. T., W. J. Cunningham, assistant to the president, N. Y. N. H. & H.; George W. Wildin, mechanical superintendent, N. Y. N. H. & H.; E. W. Holst, superintendent of equipment, Bay State Street Railway; W. C. Kendall, superintendent of car service, B. & M.; J. B. Hammill, superintendent, B. & A.; F. A. Ryer, purchasing agent, B. & A.; J. D. Tyter, general superintendent, B. & M.; L. J. Morphy, designing engineer, B. & A.

*International Engineering Congress, 1915.*—Rapid progress is being made in working out the final program of papers for the International Engineering Congress, to be held in San Francisco in 1915. The first volume of the publication of the congress will consist of a series of articles descriptive of the various technical features of the design and construction of the Panama canal. Subscriptions to the Congress are being received daily and on March 1 the number of enrollment was slightly in excess of 1,200, of which over 200 are from foreign countries and about 1,000 from the United States. Subscription blanks have been mailed through the various national societies to many thousands of engineers in this country and through the foreign societies to foreign engineers. The response already received is very encouraging, but it is trusted that all engineers interested in the success of the congress will not fail to send in their subscriptions as early as possible. Delay in so doing renders the task of the committee of management more difficult, and makes it impossible to form any just estimate of the receipts which may be expected and the number of copies of the volumes which will have to be published.

The following list gives names of secretaries, dates of next or regular meetings, and places of meeting of mechanical associations.

- AIR BRAKE ASSOCIATION.—F. M. Nellis, 53 State St., Boston, Mass. Convention, May 5-8, 1914, Detroit, Mich.
- AMERICAN RAILWAY MASTER MECHANICS' ASSOC.—J. W. Taylor, Karpen building, Chicago. Convention, June 15-17, 1914, Atlantic City, N. J.
- AMERICAN RAILWAY TOOL FOREMEN'S ASSOCIATION.—A. R. Davis, Central of Georgia, Macon, Ga. Convention, July 20-22, 1914, Hotel Sherman, Chicago.
- AMERICAN SOCIETY FOR TESTING MATERIALS.—Prof. E. Marburg, University of Pennsylvania, Philadelphia, Pa.
- AMERICAN SOCIETY OF MECHANICAL ENGINEERS.—Calvin W. Rice, 29 W. Thirty-ninth St., New York. Convention, December, 1914, New York.
- CAR FOREMEN'S ASSOCIATION OF CHICAGO.—Aaron Kline, 841 North Fifthth Court, Chicago; 2d Monday in month, Chicago.
- CHIEF INTERCHANGE CAR INSPECTORS' AND CAR FOREMEN'S ASSOCIATION.—S. Skidmore, 946 Richmond street, Cincinnati, Ohio. Convention, August 25-27, 1914, Cincinnati, Ohio.
- INTERNATIONAL RAILWAY FUEL ASSOCIATION.—C. G. Hall, 922 McCormick building, Chicago. Convention, May 18-22, 1914, Chicago.
- INTERNATIONAL RAILWAY GENERAL FOREMEN'S ASSOCIATION.—William Hall, 829 W. Broadway, Winona, Minn. Convention, July 14-17, 1914, Hotel Sherman, Chicago.
- INTERNATIONAL RAILROAD MASTER BLACKSMITHS' ASSOCIATION.—A. L. Woodworth, Lima, Ohio. Convention, August 18-20, 1914, Milwaukee, Wis.
- MASTER BOILER MAKERS' ASSOCIATION.—Haffy D. Vought, 95 Liberty St., New York. Convention, May 25-28, 1914, Hotel Walton, Philadelphia, Pa.
- MASTER CAR BUILDERS' ASSOCIATION.—J. W. Taylor, Karpen building, Chicago. Convention, June 10-12, 1914, Atlantic City, N. J.
- MASTER CAR AND LOCOMOTIVE PAINTERS' ASSOC. OF U. S. AND CANADA.—A. P. Danc, B. & M., Reading, Mass. Convention, September 8-11, 1914, Nashville, Tenn.
- RAILWAY STOREKEEPERS' ASSOCIATION.—J. P. Murphy, Box C, Collinwood, Ohio. Convention, May 18-20, 1914, Hotel Raleigh, Washington, D. C.
- TRAVELING ENGINEERS' ASSOCIATION.—W. O. Thompson, N. Y. C. & H. R., East Buffalo, N. Y. Convention, August, 1914, Chicago, Ill.

RAILROAD CLUB MEETINGS

Club	Next Meeting	Title of Paper	Author	Secretary	Address
Canadian .....	.....	.....	.....	Jas. Powell.....	Room 13, Windsor Hotel, Montreal.
Central .....	May 14	.....	.....	H. D. Vought.....	95 Liberty St., New York.
New England....	Apr. 14	Physical Valuation of Railroads.....	L. R. Pomeroy.....	Wm. Cade.....	683 Atlantic Ave., Boston, Mass.
New York .....	Apr. 17	Art of Locomotive Staybolts.....	C. A. Seley.....	H. D. Vought.....	95 Liberty St., New York.
Pittsburgh .....	Apr. 24	Braking Power .....	Walter V. Turner.....	J. B. Anderson.....	207 Penn. Station, Pittsburgh, Pa.
Richmond .....	Apr. 13	Locomotive Capacity and Superheated Steam	G. E. Ryder.....	F. O. Robinson.....	C. & O. Ry., Richmond, Va.
St. Louis .....	Apr. 10	The Vision of the Railroad Man.....	Dr. E. H. Higbee.....	B. W. Frauenthal	Union Station, St. Louis, Mo.
Southern & S'w'r .....	.....	.....	.....	A. J. Merrill.....	218 Grant Bldg., Atlanta, Ga.
Western .....	.....	.....	.....	Jos. W. Taylor.....	1112 Karpen Bldg., Chicago, Ill.

## PERSONALS

*It is our desire to make these columns cover as completely as possible all the changes that take place in the mechanical departments of the railways of this country, and we shall greatly appreciate any assistance that our readers may give us in helping to bring this about.*

### GENERAL

WILBUR M. BOSWORTH, whose appointment as mechanical engineer of the Louisville & Nashville, with headquarters at South Louisville, Ky., was announced in the March issue, was born on June 13, 1879, at Baltimore, Md., and graduated from the Baltimore Polytechnic Institute in 1898. He began railway work in July of the same year as a special apprentice on the Baltimore & Ohio at the Mt. Clare shops and three years later became draftsman at the same place. From January, 1906, to October, 1911, he was chief draftsman of the same road and then was appointed mechanical engineer of the Kansas City Southern, with headquarters at Pittsburg, Kan., leaving that position on March 1, to go to the Louisville & Nashville as mechanical engineer as above noted.

MILLARD F. COX, mechanical engineer of the Louisville & Nashville, has been appointed assistant superintendent of machinery, with headquarters at Louisville, Ky.

J. F. DUNN has been appointed superintendent of motive power of the Oregon Short Line, with headquarters at Salt Lake City, Utah.

R. PRESTON, master mechanic of the Manitoba division of the Canadian Pacific at Winnipeg, Man., has been appointed assistant superintendent of motive power of the Western Lines, with headquarters at Winnipeg.

W. E. RICKETSON has been appointed mechanical engineer of the Cleveland, Cincinnati, Chicago & St. Louis, with headquarters at Beech Grove, Ind., succeeding C. A. Brandt, promoted.

J. H. RUXTON has been appointed superintendent of motive power of the San Antonio, Uvalde & Gulf, with headquarters at Pleasanton, Tex.

GEORGE ST. PIERRE, master mechanic of the San Francisco-Oakland Terminal Railways, has been appointed superintendent of equipment, with office at Oakland, Cal.

### MASTER MECHANICS AND ROAD FOREMEN OF ENGINES

CHARLES F. BARNHILL has been appointed master mechanic of the Beaumont division of the Gulf, Colorado & Santa Fe, with headquarters at Silsbee, Tex., succeeding A. B. Adams, deceased.

A. BARROW has been appointed assistant road foreman of engines of the Pere Marquette, with headquarters at Grand Rapids, Mich.

F. BAUER has been appointed master mechanic in charge of the central division motive power work of the Cleveland, Cincinnati, Chicago & St. Louis at the Beech Grove shops, Indianapolis, Ind.

JOHN BAUER has been appointed master mechanic of the Alton, Jacksonville & Peoria, with headquarters at Alton, Ill.

C. A. BRANDT has been appointed master mechanic of the Chicago, Michigan and the Peoria & Eastern divisions of the Cleveland, Cincinnati, Chicago & St. Louis, with headquarters at Indianapolis, Ind.

W. G. COOPER has been appointed road foreman of engines of the Wabash, with headquarters at St. Thomas, Ont.

J. COOTS has been appointed supervisor of locomotive operation of the Erie, with headquarters at Jersey City, N. J.

W. H. DRESSEL has been appointed master mechanic of the

Oregon-Washington Railroad & Navigation Company, with headquarters at Portland, Ore.

G. A. GALLAGHER has been appointed master mechanic of the Illinois Southern, with headquarters at Sparta, Ill.

C. F. GREGORY has been appointed master mechanic of the St. Louis & O'Fallon, with headquarters at St. Louis, Mo.

L. F. HAMILTON has been appointed district master mechanic of the Canadian Pacific, with headquarters at West Toronto, Ont.

W. H. HOFFMAN has been appointed master mechanic of the Chicago & North Western, with headquarters at Green Bay, Wis.

W. B. KILGORE has been appointed road foreman of engines of the Cincinnati, Hamilton & Dayton at Lima, Ohio, with jurisdiction between Troy, Ohio, and Toledo.

A. F. KING has been appointed road foreman of engines of the Wabash, with headquarters at Peru, Ind.

W. J. LLOYD has been appointed master mechanic of the Oregon Short Line, with headquarters at Pocatello, Idaho.

M. J. MCGRAW has been appointed master mechanic of the Chicago & Alton at Bloomington, Ill.

J. W. MAHON has been appointed master mechanic of the Kanawha & West Virginia, with headquarters at Charleston, W. Va.

D. J. MALONE has been appointed master mechanic of the Oregon Short Line, with headquarters at Salt Lake City, Utah.

WILLIAM NAYLOR has been appointed road foreman of engines of the Chicago & Alton at Bloomington, Ill., succeeding W. H. Davies.

F. NICHOLSON has been appointed master mechanic of the Louisiana Railway & Navigation Company, with headquarters at Shreveport, La., succeeding M. F. McCarra, resigned.

W. J. RENIX has been appointed district master mechanic of the Canadian Pacific at Cranbrook, B. C., succeeding F. R. Pennyfather, promoted.

GEORGE ROSS has been appointed master mechanic of the Oregon-Washington Railroad & Navigation Company, with headquarters at La Grande, Ore.

L. RUKEL has been appointed road foreman of engines of the Wabash, with headquarters at Moberly, Mo.

J. S. SHEAFE, engineer of tests of the Illinois Central, has been appointed master mechanic of the Staten Island lines of the Baltimore & Ohio, with headquarters at St. George, Staten Island, N. Y.

B. STRAUSS has been appointed road foreman of engines of the Minnesota division of the Rock Island Lines, with headquarters at Cedar Rapids, Ia.

J. A. TSCHUON has been appointed master mechanic of the Baltimore & Ohio at Washington, Ind.

J. E. WILSON has been appointed road foreman of engines of the Pere Marquette, with headquarters at Grand Rapids, Mich.

T. E. WOLFE has been appointed road foreman of engines of the Pere Marquette, with headquarters at Grand Rapids, Mich.

ROBERT E. WOOD has been appointed road foreman of equipment of the El Paso and Mexico divisions of the Rock Island Lines with headquarters at Pratt, Kan., succeeding Edward Robertson, transferred.

L. WOSTER has been appointed master mechanic of the Cincinnati, Hamilton & Dayton, with headquarters at Ivoryville, Ohio.

### CAR DEPARTMENT

H. I. DORNER has been appointed general car foreman of the Toledo Terminal Railroad, with headquarters at Toledo, Ohio.

H. H. GERBACK has been appointed car foreman of the Great Northern at Great Falls, Mont.



J. A. MOORE has been appointed car foreman of the Canadian Pacific at White River, Ont.

S. D. PAGE has been appointed general car foreman of the Bangor & Aroostook, with headquarters at Milo Junction, Me.

W. H. PINSON has been appointed general foreman of the car department of the San Antonio, Uvalde & Gulf, with headquarters at Pleasanton, Tex.

#### SHOP AND ENGINE HOUSE

H. ALAMAN, master boiler maker of the Vandalia at Terre Haute, Ind., has retired on a pension after having been in the service of the company for 49 years.

W. F. BLACK, shop draftsman and apprentice instructor at the Oswego, N. Y., shops of the New York Central & Hudson River, has been transferred in a similar capacity to Avis, Pa., succeeding Harry S. Rauch, promoted.

CHARLES BOERTMAN has been appointed superintendent of shops of the Pere Marquette, at Saginaw, Mich.

W. A. DEEMS has been appointed general foreman of the Glenwood shops of the Baltimore & Ohio, at Pittsburgh, Pa.

C. FIFE has been appointed locomotive foreman of the Great Northern, at Casselton, N. D.

H. P. FORSBERG has been appointed shop foreman of the Chicago & North Western at Superior, Neb.

JAMES H. GASTON has been appointed general foreman of the Georgia Railroad at Augusta, Ga.

W. H. KELLER has been appointed general foreman of the locomotive and car shops of the Cincinnati, Hamilton & Dayton, with headquarters at Lima, Ohio, succeeding W. A. Deems, promoted.

N. J. LAWHON has been appointed day roundhouse foreman of the Rock Island Lines at Manly, Iowa, succeeding H. P. Jones, assigned to other duties.

CHARLES LYNCH has been appointed boilermaker foreman of the Rock Island Lines at Manly, Iowa.

A. G. McCLELLAN has been appointed foreman of locomotive repairs of the Chicago & Alton at Bloomington, Ill., succeeding W. H. Wundrie.

H. F. MARTYR has been appointed general foreman of the Manly, Iowa, shops of the Rock Island Lines, succeeding L. H. Huxton, resigned.

J. Q. MYERS has been appointed locomotive foreman of the Great Northern at Grand Forks, N. D.

HARRY S. RAUCH has been appointed general foreman of the New York Central & Hudson River shops at Avis, Pa. Mr. Rauch was born in Michigan in 1874, and served an apprenticeship as a machinist from 1891 to 1894. For the next seven years he was employed as a machinist by the Ames Iron Works Company, Oswego, N. Y. In 1901 he took a position at the Oswego shops of the New York Central & Hudson River as a machinist, and from 1904 to 1913, except for two years when he served as general manager of the Ontario Chemical Company of Oswego, he was shop draftsman and apprentice instructor at Oswego. In 1913 he was transferred to Avis, Pa., in a similar capacity, which position he held until the above mentioned appointment.

H. C. ROWLEY has been appointed general foreman of the Zanesville & Western at Fultonham, Ohio.

JOHN SIMMES has been appointed general foreman of the shops of the Cincinnati, New Orleans & Texas Pacific at Ludlow, Ky., succeeding J. G. Lewis.

G. W. THOMAS has been appointed roundhouse foreman of the Southern at Selma, Ala., succeeding J. A. Wilkins, transferred.

W. WADE has been appointed shop foreman of the Chicago & North Western at Janesville, Wis.

H. M. WARDEN has been appointed general foreman of the locomotive department of the San Antonio, Uvalde & Gulf, with headquarters at Pleasanton, Tex.

J. A. WILKINS, roundhouse foreman of the Southern Railway at Selma, Ala., has been transferred to Birmingham, Ala.

#### PURCHASING AND STOREKEEPING

F. J. ANGIER has been appointed storekeeper of the Baltimore & Ohio at Green Spring, W. Va.

T. H. BARKER has been appointed storekeeper of the Baltimore & Ohio at Benwood, W. Va., succeeding R. T. Ravenscroft.

R. M. BLACKBURN has been appointed acting general storekeeper of the Chicago & North Western at Chicago, Ill., succeeding W. M. Carroll.

C. D. BOICE, who has been in the service of the Florida East Coast for some time, at the New York office, has been appointed purchasing agent, with headquarters at New York, succeeding L. C. Haines, promoted.

C. R. CRAIG has been appointed purchasing agent of the Southern Railway at Washington, D. C., succeeding E. S. Wynn, promoted.

W. J. DUNLOR has been appointed storekeeper at the East Side terminal of the Baltimore & Ohio at Philadelphia, Pa., succeeding H. L. Mortimer.

J. F. HOYER has been appointed purchasing agent of the New Orleans Great Northern, with office at Jackson, Miss., succeeding F. L. Kinsman, resigned.

W. E. LEFAYRE has been appointed purchasing agent of the Denver & Rio Grande, with headquarters at Denver, Col.

GEORGE H. ROBINSON has been appointed purchasing agent of the Union Pacific, with headquarters at Omaha, Neb.

J. A. TURNER has been appointed purchasing agent of the Mobile & Ohio at Mobile, Ala.

J. L. WOODS has been appointed assistant purchasing agent of the Nashville, Chattanooga & St. Louis, with headquarters at Nashville, Tenn.

#### OBITUARY

ADOLPH BUTZE, formerly general purchasing agent of the Grand Trunk, died at St. Louis, Mo., on March 3, aged 68 years. Mr. Butze began railway work in 1868 with the Wabash, in whose employ he remained for some time. From 1885 to 1887 he was in the purchasing department of the Missouri Pacific, and then became private secretary to the general manager of the Chicago, Indianapolis & Louisville. He was made general purchasing agent of the Grand Trunk in 1896, retiring on January 1, 1912, under the pension rules of the company.

EDWARD BOURNE GIBBS, formerly connected with the Union Pacific at North Platte, Neb., died on March 5 at St. Louis, Mo., aged 80 years. Mr. Gibbs was manager of power and rolling stock of the old Platte County Railroad in 1863, was master of machinery and motive power of the St. Louis & Iron Mountain in 1868, and in 1880 became connected with the Union Pacific at North Platte, Neb. Later he was in charge of the Oregon division of that road at Portland, Ore., and subsequently returned to North Platte, retiring from active service in 1904.

DANIEL EDWARD FITZGERALD, until recently assistant general superintendent of motive power of the St. Louis & San Francisco, lost his life in the fire which destroyed the Missouri Athletic



D. E. Fitzgerald

Club building in St. Louis, Mo., on March 9. Mr. Fitzgerald was born at Cairo, Ill., April 20, 1869. When he was about 9 years of age he moved with his parents to a farm near Saint Marys, Kan. He attended the country schools there and later entered Saint Marys College, where he graduated at the age of 20. Immediately after graduating he went to Horton, Kan., with the Rock Island as clerk in the store department, and later became chief clerk to the master mechanic. After a few years in this position he accepted a position with the Atchison, Topeka & Santa Fe, at Topeka, Kan., in the motive power department, and was finally made chief motive power accountant. On June 1, 1904, he left the Santa Fe and accepted the position of chief motive power clerk of the St. Louis & San Francisco in the office of the general superintendent of motive power at St. Louis. On November 19, 1904, the office was moved to Springfield, Mo., and on July 1, 1909, he was appointed assistant general superintendent of motive power. He filled this position until March 1, 1914, when he resigned to become sales manager for the Pierce Oil Corporation at St. Louis. He had been in St. Louis one week, stopping at the Missouri Athletic Club, of which he was a member, when he met death in the fire which destroyed the club building on the morning of March 9, 1914. Mr. Fitzgerald was a member of the American Railway Master Mechanics' Association and also of the Master Car Builders' Association.

D. C. IDLER, formerly for 40 years master mechanic of the Vandalia, died at Indianapolis, Ind., February 23.

WILLIAM H. THOMAS, formerly superintendent of motive power of the Southern Railway, died on March 7 at his home in Philadelphia, Pa. He was born on September 27, 1842, at Colebrook, Pa., and began railway work in July, 1865, as a foreman of a lathe gang in the shops at Renova, Pa., of the Philadelphia & Erie, now a part of the Pennsylvania Railroad. He was then consecutively roundhouse foreman, acting master mechanic and foreman of the machine shops at the same place, and then was road foreman of engines on the same road. In July, 1879, he was appointed master mechanic of the Mobile & Montgomery, and the following year became master mechanic of the Nashville & Decatur and Henderson divisions of its successor, the Louisville & Nashville. From September, 1883, for two years, he was master mechanic of the Huntington division of the Chesapeake & Ohio at Huntington, W. Va., and then became superintendent of motive power of the East Tennessee, Virginia & Georgia. From September, 1894, to February, 1896, he was assistant superintendent of motive power of its successor, the Southern Railway, and then to July, 1902, was superintendent of motive power of the same road.

INDIAN LOCOMOTIVE RECORD.—A passenger locomotive on the Great Indian Peninsula has a record of nearly 1,000,000 miles run and is still in good order, according to the Advocate of India. It was built by Neilson Reid & Co., Glasgow, in 1884.

## SUPPLY TRADE NOTES

Edward A. Hawks has been appointed special representative of the department of car equipment of the Dahlstrom Metallic Door Company, Jamestown, N. Y.

Frank N. Grigg has been appointed sales agent of the Transportation Utilities Company, New York. He will have office at 1201 Virginia Railway & Power building, Richmond, Va.

George Hills has resigned as president of the Welding Materials Company, New York, to become general sales agent of the Siemens Wenzel Electric Welding Company, also of New York.

James C. Boyd, formerly chief engineer, has been elected vice-president of Westinghouse Church Kerr & Company, New York. He will have charge of all the engineering and construction activities of the company.

W. L. Anderson, formerly Chicago representative of George E. Molleson Company, New York, has been appointed manager of the railway sales department of the Union Fibre Company, Chicago.

G. W. Alden, who for the past ten years has been with the McMyler-Interstate Company, Bedford, Ohio, has resigned from that company, to become western sales manager of the Ohio Locomotive Crane Company, Bucyrus, Ohio. He will have offices in the Fisher building, Chicago.

J. N. Kinney, who has been with the American Hoist & Derrick Company, St. Paul, Minn., for the past seven years, has resigned from that company, to become eastern sales manager of the Ohio Locomotive Crane Company, Bucyrus, Ohio. He will have offices at 30 Church street, New York.

Announcement is made of the organization and incorporation of Hodgkins & Co., with offices in the Great Northern building, Chicago, for the sale of locomotive and car specialties. The officers are Edward W. Hodgkins, president and treasurer, and Charles L. Mahoney, vice-president and secretary.

H. F. Wardwell has been appointed Chicago representative of the Monarch Steel Castings Company, of Detroit, and will handle "Lion" and "Monarch" couplers and miscellaneous open-hearth steel castings in addition to his rebuilt locomotive and car business, with office at 359 Railway Exchange.

A. E. Heffelfinger has been appointed general representative for Cuba of the Richardson Scale Company, Passaic, N. J., builders of automatic weighing machinery, with headquarters at Cuba No. 76-Altos, Havana, Cuba. Mr. Heffelfinger was for a number of years with the American Car & Foundry Company.

A. H. Weston, for many years mechanical engineer of the T. H. Symington Company and located for the past two years at Rochester, N. Y., has been transferred to the sales department of that company. He will report to C. J. Symington, vice-president in charge of sales, with office at 30 Church street, New York.

Frank J. Schraeder, Jr., formerly with the Roberts & Schaefer Company, Chicago, has formed a partnership with R. E. Gurley, formerly with the T. W. Snow Construction Company, under the name of Gurley & Schraeder, to design and construct coaling stations and coal handling machinery, with offices in the Ellsworth building, Chicago.

The Permanent Manufacturers' Exhibit of Railway Appliances and Equipment now located on the twelfth floor of the Karpen building, Chicago, was discontinued on March 31; and the exhibit will be removed to the ninth floor of the Lytton building, Jackson and State streets. The exhibit will be in charge of A. Sheldon as manager, as before.

The Whiting Foundry Equipment Company, Harvey, Ill., has



arranged with S. R. Vanderbeck, 217 Walnut street, Philadelphia, Pa., to have him handle that company's complete line in Philadelphia territory. Mr. Vanderbeck also represents the Atlas Car & Manufacturing Company, Cleveland, Ohio; Orton & Steinbrenner, Chicago, and the New Jersey Foundry & Machine Company, New York.

Westinghouse Church Kerr & Company, of Montreal and New York, have been retained by the Canadian Pacific as engineers to investigate the proposed electrification of the new double-track, 5½-mile Selkirk tunnel in British Columbia. The investigations will cover in general the type of system to be installed, the relative economies of steam and water power, and the effect of the electrification upon operating conditions.

E. F. Platt, formerly connected with the Platt Iron Works, Dayton, Ohio, and C. A. Kurz, Jr., of the Kurz Laboratories, have organized The Electrolytic Gas Company at Dayton. This company has secured the Western selling agency of the International Oxygen Company of New York, and it is the intention to proceed with the installation of a number of electrolytic plants for the production of oxygen and hydrogen in different parts of the country.

Stanley W. Midgley, for several years western sales manager of the Curtain Supply Company, has been appointed general sales manager of the Acme Supply Company, with headquarters in the Steger building, Chicago, effective on March 4. Mr. Midgley has been in the railway supply business for the past twelve years, beginning with the National Car Coupler Company as general sales representative, and for the past six years he has been with the Curtain Supply Company as western representative and western sales manager, until his appointment to the present position. Mr. Midgley is the oldest son of J. W. Midgley, who was for over twenty years the commissioner of the Western Freight Association, which comprised



S. W. Midgley

the several railroads extending westward from Chicago and St. Louis.

The Duff Manufacturing Company, Pittsburgh, Pa., manufacturers of Barrett track and car jacks, Duff ball-bearing screw jacks and Duff-Bethlehem hydraulic jacks, has opened an office in the Peoples Gas building, Chicago. The same company has recently appointed G. W. Parsons, district sales agent, with offices in the Pioneer Building at St. Paul, Minn. The company also announces that by mutual agreement the Fairbanks Morse Company has discontinued acting as exclusive steam railway agents for the Duff jacks.

The employees of the Westinghouse Electric & Manufacturing Company who have been in its employ for 20 years or more, held a meeting on February 21 and organized the Veteran Employees' Association of the Westinghouse Electric & Manufacturing Company. A regular business meeting was held to formulate the organization, a set of by-laws was adopted and officers elected for the coming year. A dinner followed at which the toastmaster was L. A. Osborne, vice-president. The speakers were E. M. Herr, president; Charles H. Terry, vice-presi-

dent, and James J. Barrett, representing the shop. Mr. Herr and Guy E. Tripp, chairman of the board of directors, who was also present, were elected honorary members. About 325 of the employees are eligible to membership, and over 300 of these were present.

J. T. Anthony has been appointed assistant general eastern sales manager of the American Arch Company, New York. Mr. Anthony was born in February, 1883, and graduated from the Georgia School of Technology in 1902. He was then engaged in the textile manufacturing business for a few years and entered the service of the Atlantic Coast Line in 1905. In 1907 he became a draftsman in the motive power department of the Central of Georgia. He remained with that road until 1912, being closely associated with F. F. Gaines, superintendent of motive power, in the work of designing the Gaines combustion chamber. In January, 1912, he entered the employ of the American Arch Company as combustion engineer. One



J. T. Anthony

year later he was made assistant to the president and held that position until March 1, 1914, when he was made assistant general eastern sales manager as noted above.

Harlow D. Savage has been appointed general eastern sales manager of the American Arch Company, 30 Church street, New York. Mr. Savage was born at Memphis, Tenn., on April 16,



H. D. Savage

1880. He received his education in the public schools of Ashland, Ky., and at Kenyon Military Academy. Since June, 1897, he has been connected with the Ashland Firebrick Company, Ashland, Ky., having reached the position of assistant secretary and that of treasurer and sales manager. While at Ashland he was at one time in charge of mines of this company and later had complete control of operation. As a part of the latter work he designed and constructed a modern electrically operated firebrick plant at Ashland. He takes up

his new work with the American Arch Company, therefore, with a thorough knowledge of the manufacturing side of its business. Mr. Savage is the president of the German Mining & Manufacturing Company and of the Clinton Mining Company. He is a director of the Ashland Firebrick Company and of the Clinton Mining Company. He also holds the position of president of the Refractories Manufacturers' Association. Mr. Savage is also a military aid to the governor of Kentucky with the rank of colonel.

## CATALOGS

**OIL SWITCHES.**—The General Electric Company, Schenectady, N. Y., has just issued bulletin No. 47,400, illustrating and describing the type F, form K12 oil switches. This supersedes a previous bulletin on this subject.

**REGRINDING VALVES.**—The National Tube Company, Pittsburgh, Pa., has recently issued a 14 page booklet setting forth the advantages of that company's regrinding valves. This book takes up the design and construction of these valves in the form of a series of questions with their answers.

**IRON PIPE.**—Bulletin No. 11B issued by the National Tube Company, Pittsburgh, Pa., is devoted to the subject of pipe. The bulletin contains 28 pages, and is arranged in the form of chapters, one of which gives a short history of pipe and the early methods of manufacture. The bulletin is completely illustrated.

**BRASS FOUNDRY EQUIPMENT.**—Catalog No. 108, which supersedes catalog No. 91 of the Whiting Foundry Equipment Company, Harvey, Ill., has just been issued. This deals with the brass foundry equipment manufactured by that company, which includes brass furnaces, tilting brass furnaces, crucible tongs, tumblers, etc.

**INDUCTION MOTORS.**—Two or three phase, 60 cycle induction motors for general use are the subject of a bulletin from the Crocker-Wheeler Company, Ampere, N. J. The illustrations show these motors as applied in a number of industries, and also give full details of the construction. Accessories are also briefly considered.

**PICKLING MACHINES.**—A catalog from the Mesta Machine Company, Pittsburgh, Pa., fully illustrates and describes the machines it has developed for reducing the labor and improving the results in removing the scale and other substances from the surface of metals by the chemical action of acids, an operation commonly called pickling.

**BURNING FUEL OIL.**—The Gilbert & Barker process for burning fuel oil under low pressure and the equipment used is fully discussed in a catalog prepared by Gilbert & Barker Manufacturing Company, Springfield, Mass. Equipment used for various purposes, especially in connections with hardening and tempering is illustrated in several styles.

**CLEVIS FOR UNCOUPLING RODS.**—Circular No. 66 of the National Malleable Castings Company, Cleveland, Ohio, deals with the National safety clevis and pin, a device which has been developed by that company to prevent the detaching of uncoupling rods from the coupler locking mechanism because of the loss of the cotter from the clevis pin.

**ELECTRIC FANS.**—The Sprague Electric Works of the General Electric Company, New York, has issued a 35 page catalog devoted to the various types of electric fans manufactured by that company. The catalog describes the different types of direct and alternating current fans with data pertaining to each one. It is well printed and illustrated.

**OILSTONE GRINDERS.**—The Mummert-Dixon Company, Hanover, Pa., has recently issued catalog No. 5, dealing with oilstone grinders. These machines are designed for sharpening edge tools, general grinding, beveling knives, etc. The catalog contains 30 pages, and includes line drawings and half-tone illustrations of the company's various types of grinders.

**FOREIGN ROLLING STOCK.**—The Gregg Company, Ltd., Hackensack, N. J., is issuing a catalog devoted principally to illustrations of the equipment it has designed and is prepared to furnish for plantation railways. This company also designs and manufactures castings, forgings and other car parts as well as portable tracks, frogs and switches, etc. for narrow gage lines.

**FLOW INDICATOR.**—Bulletin No. 57, issued by the Richardson-Phenix Company, Milwaukee, Wis., illustrates and describes the application of the Phenix Sight Flow Indicator to any pipe line carrying a liquid. This device indicates electrically by lighting a lamp or ringing a bell when the flow of liquid is interrupted. Several recent improvements embodied in it are described.

**LOCOMOTIVE CRANES.**—Illustrations showing locomotive cranes in operation occupy the larger part of the 71 page catalog being issued by The Browning Company, Cleveland, Ohio. A complete description of the design of locomotive crane developed by this company is given in the fore part of the catalog and illustrations of all the more interesting and important details are shown.

**SAFETY BRAKE LEVERS.**—Circular No. 65, issued by the National Malleable Castings Company, Cleveland, Ohio, is devoted to the National safety brake lever. The main feature of this lever is the provision of two safety lugs, one cast on each side just above the fulcrum pin hole, which strike against the edges of the fulcrum in case the pin comes out and prevent the lever from slipping through.

**ENGINE TRUCKS.**—A four page bulletin, No. 101, recently issued by the Economy Devices Corporation, 30 Church street, New York, deals with the Economy two wheel engine truck, one of the principal features of which is a bolster arrangement which gives a constant resistance to displacement. This truck was described in the Railway Age Gazette, Mechanical Edition, March, 1914, page 154.

**TOOL STEEL.**—An 80 page catalog from E. S. Jackman & Company, 710 Lake street, Chicago, describes the method employed by the Firth-Sterling Steel Company in making fine tool steels. It also contains a chapter on the selection of steel for different purposes and the heat treatment of the different grades of steel. Weight tables and other useful information in connection with this subject are also included.

**THERMOSTATIC CONTROL FOR STEAM HEAT SYSTEMS.**—The Gold Car Heating & Lighting Company, 17 Battery Place, New York, has recently issued a pamphlet dealing with the electric thermostatic control developed by that company for controlling the temperature in steam heated cars. Illustrations of the device are included, as well as the report of a comparative test between the thermostatic control and the Gold straight steam system.

**CRANES AND HOISTS.**—The Northern Engineering Works, Detroit, Mich., has just issued catalog No. 26, illustrating the electric traveling cranes, hand power traveling cranes and electric and pneumatic hoists manufactured by that company, as well as overhead track system bucket handling cranes and railway cranes. This is a condensed catalog, but contains references to various bulletins which more fully explain the numerous designs.

**LOCOMOTIVE HOISTS.**—This is the subject of a 14 page catalog, No. 105, issued by the Whiting Foundry Equipment Company, Harvey, Ill. This catalog outlines the advantages claimed for the hoists manufactured by this company for wheeling locomotives and fully describes the construction and operation. Photographs of actual installations show the different steps in operating the hoists. A list of the various railways using this type of hoist is included.

**AUTOMATIC CONNECTORS.**—The Robinson Coupler Company, Washington, D. C., has just issued a report of a recent test of the company's automatic air and steam hose connector made on the Great Northern at Grand Forks, B. C. This report has been very handsomely arranged; the printing is excellent and the illustrations in every case are actual photographs. The report includes comments by the Interstate Commerce Commission regarding the tests.

**AIR COMPRESSOR EFFICIENCY.**—The Laidlaw-Dunn-Gordon Company, Cincinnati, Ohio, is making a practice of issuing information bulletins whenever information of a definite engineer-



ing value and interest in connection with air compressors is available. The latest bulletin is No. 22, and is devoted to a thorough discussion of air compressor efficiency and the factors which control it. It contains eight pages of solid type and summarizes in the form of five conclusions.

**LOCK WASHERS.**—The Reliance Manufacturing Company, Massillon, Ohio, makes nothing but Reliance lock washers and gives particular attention to the quality of material used and the most careful inspection during the manufacturing as well as the heat treatment of the material. A catalog recently issued by this company contains illustrations of a number of types of lock washers or nut locks manufactured by it, each being accompanied by a table giving the range of sizes and the prices.

**BORING AND DRILLING MACHINE.**—A booklet from Pawling & Harnischfeger Company, Milwaukee, Wis., is entitled, "Difficult Drilling and Boring Made Easy." It briefly describes the Pawling & Harnischfeger drilling and boring machines but is principally devoted to illustrations of difficult operations that are performed easily with this machine. In connection with each of these illustrations, which are actual photographs taken in various shops, is a brief description of the operation shown.

**GOVERNOR FOR MOTOR-DRIVEN AIR COMPRESSORS.**—The General Electric Company, Schenectady, N. Y., recently issued bulletin No. 44,590 under the above heading. The function of the type ML governor, described in this bulletin, is to automatically control the operation of either stationary or railway motor-driven air compressors in order to maintain air pressure in a storage reservoir between predetermined limits. This bulletin supercedes the company's previous bulletin on the same subject.

**TRAVELING CRANES.**—The new type "H" crane developed by the Pawling & Harnischfeger Company, Milwaukee Wis., has been designed with a full consideration of the new liability laws which are now in force in various states and matters of safety have been given particular attention. This crane is fully illustrated and described in bulletin No. 401 where illustrations of the various detail features show the improved construction to good advantage. The bulletin is entirely devoted to this type of crane.

**STAYBOLT DRILLING MACHINE.**—Two leaflets from the Richmond Staybolt Drilling Machine Manufacturing Company, Richmond, Va., briefly illustrate and describe the two types of machines manufactured by this company for drilling locomotive staybolts. These are practically the same machine, one arranged in a horizontal form and the other vertically. The latter arrangement also provides a drilling machine which can be used for other purposes as well and will drill any depth hole up to 1½ in. depth and ⅜ in. in diameter.

**BALL BEARINGS.**—A full description of the different processes in the manufacture of the S. K. F. self aligning ball bearing forms a part of bulletin No. 11 from the S. K. F. Ball Bearing Company, 50 Church St., New York. Other parts of this bulletin show applications of these bearings to various machines and rolling stock, some operating under the most difficult conditions of speed and misalignment. The bulletin also contains tables giving the sizes, weight, etc. of the various types of bearings manufactured by this company.

**POSTAL CAR LIGHTING.**—The Safety Car Heating & Lighting Company, 2 Rector St., New York, is issuing a supplement to its form No. 1116, dated April 1913, in connection with postal car lighting. It is devoted to the spacing of light units for 60 ft standard steel full postal cars and is issued on account of a change made by the Post Office Department in the arrangement of registered letter cases in this size car. It contains the same form of illustrations given in the previous pamphlet, corrected according to the new requirements.

**MODELS FOR CLASS ROOM WORK.**—A leaflet from the Chicago Mathematical Supply House, 2019 Mohawk street, Chicago, il-

lustrates and describes the Hanstein models, Goniostat and Rotostat which are constructed for the assistance of beginners in forming correct comprehension of problems in projection, solid and descriptive geometry and mechanical drawing. These models are very unique in their arrangement and conception. The complete set allows more than 500 possible mountings in skeleton form, each of an average height of 2 ft.

**DIRECT CURRENT MOTORS.**—The round type, single field coil, direct current motors manufactured by the Sprague Electric Works of the General Electric Company have been on the market for many years and are unique in that a single field coil is used to energize the poles, making the motor exceptionally simple, compact and well protected. These motors are manufactured in nine sizes from ¼ h. p. to 7½ h. p., and are fully described in bulletin No. 247 issued by the Sprague Electric Works, 527 West Thirty-fourth street, New York.

**TRAVELING CRANES.**—A 90 page fully illustrated, large size catalog is being issued by the Niles-Bement-Pond Company, 111 Broadway, New York, for the purpose of giving a general idea of the various types of cranes, trolleys and hoists built at its extensive crane works in Philadelphia. The catalog shows first the principal details of the Niles standard electric crane in a very complete manner. Each important part of the construction is illustrated and fully described. The latter part of the catalog is largely devoted to illustrations of many different types of cranes, trolleys and hoists in operation, there being a brief note under each photograph stating its location and any special features of interest in connection with that particular installation. Many of these illustrations are taken from railroad shops.

**PYROMETERS FOR SUPERHEATED STEAM LOCOMOTIVES.**—The value of an accurate knowledge of the temperature of the steam at the steam chest of a superheated steam locomotive in connection with its influence on the proper operation by the engineer has been recognized on foreign railways for a number of years. The comparatively few installations of pyrometers that have been made in this country quickly demonstrated that it is of equal value under American conditions. The Locomotive Superheater Company, therefore, has, after a long series of experiments and tests, finally developed a thoroughly practical pyrometer equipment which is now being fitted to a number of superheater locomotives. A circular from that company illustrates this equipment and describes its construction, installation and operation. In addition to the circular, the same company has issued an instruction book which describes the equipment in detail and gives full explanations of how to apply, adjust and maintain it.

**STREET LOCOMOTIVE STOKER.**—The type C stoker of the Locomotive Stoker Company, 30 Church St., New York, is fully illustrated and described in a recent catalog. This new design differs from the previous type B only in the steam engine which runs it and in the sprocket wheel casing. The type B machine had a constant speed engine and a gear box on the elevator for throwing the screw conveyor in and out of gear and for changing the speed at which it runs in relation to the elevator. The type C has an engine which can be run at seven different constant speeds, varying from 400 r. p. m. to 600 r. p. m. and is equipped with a friction clutch which will permit the stopping of the elevator while the engine continues in operation. The gear box used on the type B has been omitted on the type C machine and this connection is now fixed. The friction clutch on the type C is one of the most important improvements in the new machine as it furnishes a means for instantly stopping the flow of coal to the firebox and leaving the elevator buckets filled with coal ready to begin feeding again when the clutch is thrown in. Furthermore, the speed changing device gives the fireman absolute control of the quantity of coal to be fed to the fire. This design is most fully illustrated and thoroughly described in the catalog.

# Railway Age Gazette

MECHANICAL EDITION

INCLUDING THE AMERICAN ENGINEER

PUBLISHED ON THE FIRST THURSDAY OF EVERY MONTH BY THE SIMMONS-BOARDMAN PUBLISHING COMPANY, WOOLWORTH BUILDING, NEW YORK, N. Y.

CHICAGO: Transportation Bldg. CLEVELAND: Citizen's Bldg. LONDON: Queen Anne's Chambers, Westminster.

EDWARD A. SIMMONS, President L. B. SHERMAN, Vice-President HENRY LEE, Secretary The address of the company is the address of the officers.

ROY V. WRIGHT, Editor R. E. THAYER, Associate Editor A. C. LOUDON, Associate Editor GEORGE L. FOWLER, Associate Editor

Subscriptions, including the eight daily editions of the Railway Age Gazette published in June in connection with the annual conventions of the Master Car Builders' and American Railway Master Mechanics' Associations, payable in advance and postage free:

United States, Canada and Mexico.....	\$2.00 a year
Foreign Countries (excepting daily editions)....	3.00 a year
Single Copy .....	20 cents

Entered at the Post Office at New York, N. Y., as mail matter of the second class.

WE GUARANTEE, that of this issue 4,300 copies were printed; that of those 4,300 copies, 3,706 were mailed to regular paid subscribers and 150 were provided for counter and news companies' sales; that the total copies printed this year to date were 21,606—an average of 4,320 copies a month.

VOLUME 88

MAY, 1914

NUMBER 5

## CONTENTS

### EDITORIALS:

June Dailies for Foreign Subscribers.....	221
The Erie Triplex Locomotive.....	221
May and June Conventions.....	221
The Draft Gear Competition.....	221
Pennsylvania Superheater Tests.....	222
Conservation of Motive Power.....	222
Pops and the Coal Pile.....	222
Competition on Engine House Work.....	222
Locomotive Fuel Economy.....	222
New Books .....	223

### COMMUNICATIONS:

Strength of Locomotive Boilers.....	224
Questions for Car Designers.....	225
Turning Effort of Lehigh Valley Locomotive.....	225

### GENERAL:

Triplex Locomotive for the Erie (with an inset).....	227
Tests of Superheater Performance.....	230

### CAR DEPARTMENT:

What Should Be Done with Wooden Underframe Cars.....	235
Car Department Organization and Efficiency.....	235
Canadian Pacific Steel Coach.....	237
Tests of Refrigerator Cars.....	241
Shop for Steel Car Construction.....	242
Reinforcing Old Wooden Freight Cars.....	246

### SHOP PRACTICE:

Notes on Present Day Running Repairs.....	247
Punching Holes in Brake Staffs.....	248
An Efficient Piece Work System.....	249
Gages for Flexible Staybolt.....	253
Fuel Oil Burner.....	253
A Home-made Powdered Coal Plant.....	254
General Machine Tool Efficiency.....	255
Air Valve Gages .....	258

### NEW DEVICES:

Angle Compound Power Driven Air Compressor.....	259
Street Type C Locomotive Stoker.....	260
Christy Steel Freight Car Roof.....	261
Standard Locomotive Scale.....	262
Metal Cutting and Welding with Oxygen and Pintch Gas.....	263
Sellers Coupling Nut.....	264
Water Heater .....	265
Machine for Washing, Drying and Ironing Blue Prints.....	265
Oxy-Acetylene Welding and Cutting Torches.....	266
Electric Thermostatic Control of Steam Heating.....	267
Portable Electric Hoist.....	267
Link Grinding Machine.....	268
Cutting Off and Reaming Machine for Pipe and Tubes.....	268
Clock Attachment for Boyer Speed Recorders.....	269
Constant Service Wheel Truing Brake Shoe.....	269
Safety Wrench for Hopper Cars.....	270
Asbestos Carlining .....	270

### NEWS DEPARTMENT:

News .....	271
Meetings and Conventions.....	271
Personals.....	273
Supply Trade Notes.....	275
Catalogs .....	276

### June Dailies for Foreign Subscribers

If foreign subscribers to the Mechanical Edition of the Railway Age Gazette will advise us at once whether they wish to have the daily editions of the Railway Age Gazette, which are published during the Atlantic City conventions of the Master Car Builders' and Master Mechanics' Associations, we shall be glad to see that they are forwarded to them; otherwise, if they are not specially requested, they will not be mailed to them because of the very considerable expense involved. Subscribers in the United States, Canada and Mexico will, of course, be furnished with copies of the Dailies.

### The Erie Triplex Locomotive

In the Triplex locomotive recently completed by the Baldwin Locomotive Works for the Erie is attained a new "largest locomotive." This engine not only exceeds in total weight the 2-10-10-2 type Mallet locomotives of the Santa Fe, but by the placing of a group of cylinders and driving wheels under the tender, a large proportion of the weight of the latter is made use of for adhesive purposes. There are many interesting features about the locomotive, but after a study of the machine there undoubtedly will be some doubts as to its practicability. However, this cry has been raised so many times and later proved to be without foundation that critics would do well to withhold comment. The locomotive has not yet been given a thorough service test and as it constitutes an entirely new departure in locomotive design, the service results will be awaited with interest.

### May and June Conventions

Our next issue will be largely in the nature of a convention number, and will contain comprehensive reports of the Air Brake Association, which meets at the Hotel Pontchartrain, Detroit, Mich., May 5-8; the Railway Storekeepers' Association, which meets at the Hotel Raleigh, Washington, D. C., May 18-20; the International Railway Fuel Association, which meets at the Hotel La Salle, Chicago, May 18-21; and the Master Boiler Makers' Association, which meets at the Hotel Walton, Philadelphia, Pa., May 25-28. Announcements of the programs of these conventions will be found elsewhere in this issue. In each case the indications point to more than ordinarily successful meetings. Closely following these will come the mechanical department conventions at Atlantic City, the Master Car Builders' Association meeting, June 10-12, and the American Railway Master Mechanics' Association, June 15-17. Mechanical Edition subscribers in this country will, of course, receive the eight dailies which are issued during these two conventions.

### The Draft Gear Competition

Remember that the draft gear competition, which was announced in the March and April issues, will close on May 15. It is surprising when we consider the importance of this subject that so many of the roads have given it so little careful and intelligent study. Many of them have introduced friction gears to a considerable extent and yet when called on for an exact statement of their advantages are unable to reply with any definiteness. Officers of other roads may give a good idea of the advantages as they see them in handling the cars on the repair track. Few of them, however, are able to cover the matter with any degree of satisfaction. Our aim in announcing this competition, realizing as we do the far-reaching importance of the subject, was to draw out and place on record as much as possible of the results which have thus far been demonstrated and ascertained from the use of the higher capacity draft gears. If you can contribute anything to this discussion, you may rest assured that it will be very thoroughly appreciated by the railroads throughout the country. A first prize of \$100 will



be awarded to the contestant who can develop the best practical information concerning the most desirable type of draft gear. Articles which are accepted for publication, but which are not awarded the prize, will be paid for at our regular space rate.

#### Pennsylvania Superheater Tests

The testing plant at Altoona has again furnished an important contribution to the knowledge of locomotives gained by scientific study, in the tests of superheater performance recently completed there. The paper embodying the results of these tests and presented on April 30 before the Franklin Institute, Philadelphia, by C. D. Young, engineer of tests of the Pennsylvania Railroad, probably contains the most complete data on superheater performance yet available. While a number of definite conclusions are to be drawn from the results of these tests, probably that which will possess the most general interest is the confirmation of the widely-held belief that high-degree superheating is the most economical. We give in this issue only that portion of the paper pertaining to the tests and their results. The first part of the paper contained a most interesting and valuable collection of historical data on the subject of superheated steam for locomotives.

#### Conservation of Motive Power

An analysis of the movement of locomotives during the 24 hours of the day will show that they are in actual revenue service but a very small percentage of the time—usually from 15 to 20 per cent. It will also show that they are in the hands of the mechanical department most of the time—usually from 50 to 65 per cent. For economic reasons it is desirable to have locomotives in revenue service as much as possible, and were they in use twice as much as they now are, or from 30 to 40 per cent of the time, only one-half the present number would be required and the capital tied up in locomotives would be reduced 50 per cent. To make this saving requires the greatest amount of co-operation between the transportation department and the mechanical department. It should be the aim of the mechanical department to turn the engines as rapidly as possible at the terminals, having them ready for their next trip out in the shortest possible time. By doing this the question of superfluous power will be a matter of poor scheduling of the service, a matter which could easily be remedied. The saving of one locomotive would mean a saving in interest charges of \$1,000 to \$1,500 per year, showing that even the smallest increase in the revenue mileage of locomotives would be productive of a material ultimate saving. Many roads have found that the terminal inspection pit has been a large factor in reducing the turning of locomotives at terminals.

#### Pops and the Coal Pile

It has often been said that the subject of fuel economy is as old as the steam engine, but that does not prevent one from continually preaching it. The study of the economical use of fuel is most interesting, as there are so many ways in which it may be used to better advantage. Wasting fuel at the pops is worse than deliberately burning up money, for in the first case a man is working hard (shoveling coal) to no purpose, throwing away his energy and the company's money, while, as to the second case, the man who will burn up his money usually is in such circumstances that the loss to him is negligible. A 3½ in. pop blowing for a minute wastes about 20 lb. of coal, which with coal at \$2 per ton is at the rate of \$0.02 per minute. This may not seem large, even though it is more than twice the wages of the fireman, but if all the sixty odd thousand locomotives in this country were allowed to blow off one-half hour out of the twenty-four, \$36,000 would be literally thrown away daily—which is at the rate of over 13

million dollars a year. The firemen are not always responsible for this waste. The engineer may, in numerous ways, help to avoid it. He should let his fireman know when he is about to shut off and can also greatly assist by operating the injector at the right time. The roundhouse men are also responsible for a certain amount of this waste. Anyone who is at all familiar with engine house practices knows how common it is to see locomotives which are awaiting the arrival of the crews, standing with the pops open a large percentage of the time. By carefully handling the fires while the engine is under their care they will help to prevent the engine throwing away good fuel via the pops. The men should be made to see that the elimination of such waste is the elimination of just so much work for them.

#### Competition on Engine House Work

Running repairs to locomotives are made under conditions which not infrequently require considerable ingenuity for their successful accomplishment. The increased sizes of locomotives within recent years and the bringing into general use of superheaters and other special devices have necessitated changes in engine house repair methods and in some cases the adoption of entirely new practices. Although it has taken some railway men a long time to realize what may be accomplished by adequate running repairs, there are now many railways on which the engine house more nearly obtains the recognition which it should have than has commonly been the case in the past. In order to show some of the best practices in modern engine house work a prize of \$50 is offered for the best article on the handling of engine house work which is received before July 15, 1914. The article may deal with any phase of locomotive repairs which pertains to roundhouse work, such as organization of forces, injector and air brake repairs, handling of work reports, boiler inspection and repairs and boiler washing. A subject that may appeal to men who are located at outlying points is that of making heavy repairs where the machine tool equipment is inadequate. While such work, whenever possible, is done at the larger engine houses, it occasionally becomes necessary to turn out quite extensive work at a small terminal. These subjects are merely given as suggestions and competitors are at liberty to choose any subject which comes under the head of roundhouse work. The judges will base their decision on the practical utility of the suggestions which are made or the practices which are described. Space rates will be paid for articles which are accepted for publication but do not win the prize.

#### Locomotive Fuel Economy

Remarkable advances have been made in the economical use of fuel in locomotives since the publication in the American Engineer of April, 1908, of what was probably the first comprehensive and thorough published study on this subject. In the latter part of the same year, November 20, 1908, the International Railway Fuel Association was organized at Chicago with a membership of 35. Doubtless the above mentioned article may have been one of the principal sources of inspiration which brought about this development.

Everything connected with the operation of a locomotive or the movement of a train has some effect, direct or indirect, on the fuel consumption. The appreciation of this fact, more than any other factor, has undoubtedly been the cause of the increased responsibilities which have been placed upon the shoulders of many of the railway officers of that new class which has sprung into existence within the past few years, which is charged with securing more efficient use of the locomotive fuel. As an example of this, the practice on the St. Louis & San Francisco may be referred to. The head of the fuel department reports direct to the general manager and has the title of superintendent of locomotive performance. His assistants rank with the as-

sistant division superintendents and have equal authority. The department not only controls the handling and, to a certain extent, the loading of locomotives, but looks after their proper distribution over the system. This is because of the fact that fuel economy and efficient operation under ordinary conditions are practically synonymous.

With this in mind it is interesting to note from an article which appears in the current issue of the Railway Age Gazette just what is considered as the most vital point in the campaign for fuel economy that is now being carried on on the Frisco. Is it the compilation and enforcement of rules and regulations as to the detail and proper methods of using the fuel or handling the locomotives? No. What, then, is it? The whole campaign, which has proved tremendously successful up to the present time, is based on the fact that the average man is anxious to do his best and thus to protect his reputation and his home. If he makes mistakes it is more often due to the fact that he has not been properly instructed in his work, rather than to a desire on his part to be indifferent. To secure the best results from the engineman, therefore, requires a painstaking and thorough campaign of education which will reach each individual and inspire him to the proper performance of his duties. It requires even more than this. Human nature is such that an individual check must be kept on the performance of each man in order to follow his progress and make sure that he understands what is required of him, and thus to emphasize the necessity of his giving his best efforts to the work.

The method of checking the performance of each engineer and fireman as the assistant superintendent of locomotive performance rides the locomotive, and the way in which this information is used, are, therefore, worthy of careful consideration. If an engineer is marked "good" in the various operations in which he is concerned, including the handling of the reverse lever, throttle, brake valve, lubrication and injector, and in co-operating with the fireman and inspecting the locomotive, and this happens for three successive trips on which the assistant superintendent of locomotive performance accompanies him, then he is given a letter of commendation from his supervisors and the fact is noted on the personal record. If his record is not good in any of the above mentioned respects, then the assistant superintendent of locomotive performance coaches him carefully and consistently until his work shows marked improvement. The same thing is true of the work of the fireman; in riding the engine the assistant superintendent of locomotive performance makes a note of the condition of the fire, the average number of scoops of coal used per mile, the number of times the grates are shaken, the number of times the pops are opened, the handling of the injector, the attention to duties and the use of the blower. The result is that those in charge have available a record which gives a good idea of the ability and performance of each of the engineers and firemen in the organization, and the men realize it and do their best to improve their performance.

The Northern Pacific has also been doing some special educational work of quite a different nature among its enginemen for the past three years, with excellent results. A fuel instruction car has been fitted up, as was described in the Railway Age Gazette of May 1, and each of the engineers and firemen on the system is required to take a course of three lectures which is given in the car. The purpose of these lectures or demonstrations is to give these men an excellent and clear-cut idea of the theory of combustion and the necessity of using their brains in performing their work. The experiments are simple and easily understood. They appeal to the intelligence of the enginemen and have resulted in a marked improvement in the work of these men. Another important system, but covering a much smaller territory, has also placed a fuel instruction car in service within the past few weeks. Its equipment and the methods of instruction are quite different from those employed on the Northern Pacific and the results which follow its introduction will be watched with much interest.

## NEW BOOKS

*Tests of Metals at Watertown Arsenal.* 144 pages. 5¼ in. by 9 in. Illustrated. Published by the Government Printing Office, Washington, D. C. Bound in cloth.

This book is a report of the tests of metals and other materials made with the United States testing machine at Watertown Arsenal, Massachusetts, during the fiscal year ended June 30, 1913. It contains a great deal of valuable information, considerable of which is arranged in tabular form, while a number of diagrams are included. Microphotographs of different metals are included in the illustrations and the half-tone work throughout is exceptionally good.

*Car Interchange Manual.* Bound in paper. 128 pages. Size 6 in. by 9 in. Published by J. D. MacAlpine, Cleveland, Ohio. Price, 50 cents; \$4.50 per dozen; \$30 per hundred.

This book includes an abstract of all the decisions rendered by the arbitration committee of the Master Car Builders' Association, from cases one to 943. It has been compiled by the publisher with the purpose of providing a ready and concise work of reference to the previous decisions of the arbitration committee. It is thoroughly indexed, and every effort has been made to abstract the cases as briefly as possible while conveying the meaning of the decisions. Abstracts of cases that are of little importance as precedents have usually been made shorter than those of important cases. By doing this it has been found possible to keep the book within the limits of a convenient size. The last decision, 943, was rendered in September, 1913. The last pages of the book contain price lists for repairs as adopted by the Master Car Builders' Association, and also reference tables that are of value to car men.

*Coal Mining Practice in District I'III (Danville).* By S. O. Andros. 47 pages. 6 in. by 9 in. Illustrated. Bound in paper. Published by the Department of Mining Engineering, University of Illinois. Copies may be obtained by addressing State Coal Mining Investigations, Urbana, Ill.

Illinois is producing 62 million tons of coal per year, more than one-eighth of all the bituminous coal mined in the United States. The safety of the miners and the efficiency of the mining methods employed in the state are therefore matters of national concern. The Department of Mining Engineering of the University of Illinois, the State Geological Survey, and the United States Bureau of Mines have co-operated during the past three years to study Illinois mining conditions. The information collected at 100 mines is published in district reports. In Bulletin No. 2 are discussed causes of accidents to miners in Vermilion and Edgar counties, loss of natural resources by wasteful methods of blasting and mining, use of steel and concrete as substitutes for timber in the mines and other phases of underground mining. The bulletin also contains a description of the methods of removing the overburden from a coal bed by steam-shovel, a system of mining which has been highly developed in this district.

*The Engineering Index Annual for 1913.* Compiled from the Engineering Index published monthly in the Engineering Magazine during 1913. 508 pages. 6½ in. by 9 in. Bound in cloth. Published by the Engineering Magazine Company, 140 Nassau street, New York. Price \$2.

This volume of the Engineering Index is the twelfth since the work was first undertaken and the eighth since it assumed the annual form, giving a continuous index to the engineering and technical literature of the past 30 years. The classified system of arranging the items is followed in place of the strict alphabetic order of the earlier volumes. The book was placed on the market this year considerably earlier than has usually been the custom in the past, this being attained by a great deal of special effort. The list of publications and transactions reviewed has been carefully scruti-



nized and the standard materially raised during the past 12 months. These now include the proceedings of such institutions as the Institution of Mining Engineers and the Faraday Society. Careful thought has been given to the classification, to the assignment of articles to the different divisions of the classification to which they seem most logically to relate and to cross references under all other headings where anyone using the Index might make his first search. This book is of great value to anyone concerned in engineering work of any nature.

*Applied Mechanics.* By C. E. Fuller and W. A. Johnston, professors of Theoretical and Applied Mechanics, Massachusetts Institute of Technology, Boston, Mass. 380 pages, 6 in. by 9 in. Bound in cloth. Illustrated. Published by John Wiley & Sons, Inc., New York. Price \$2.50.

This is the first volume of a series of books on applied mechanics that are to be written by the authors. It is written primarily for students who have had a preliminary training in the principles of mechanics, such as is given in a course of physics, and in the elements of mechanism. Volume I deals with statics and kinetics. It contains five chapters; the first is a general introduction; the second, on statics, includes a thorough discussion of forces; the third, on center of gravity, discusses both plane surfaces and solids; the fourth, on moment of inertia, is handled in a similar manner, and the fifth, on kinetics, including kinematics, work, power and energy, friction, kinetics of rigid bodies having plane motion only, and impact. This book is probably the most complete work written on these subjects, as the authors have had many years of successful experience in teaching applied mechanics, and fully appreciate what a student of this subject requires. It is evident from the way in which the book is written that the authors have taken advantage of their teaching experience, and as a result have presented a book that may be readily digested by the student. Efforts have been made to keep away from complicated expressions with a view to simplicity, and where it has been thought necessary, illustrative examples have been added to make the work more readily understood.

*Good Engineering Literature.* By Harwood Frost. 5 in. by 7½ in. 407 pages. Bound in cloth. Published by the author and distributed by the Chicago Book Company, 226 South La Salle street, Chicago. Price \$1.

As is truly stated in the preface of this book, every engineer is, sooner or later, called on in the course of his professional duties to do some form of literary work. Then he finds that the ability to speak and write clearly and forcibly, to express his thoughts and understandings and to describe his work so that others will understand it, will prove one of the most valuable items in his mental equipment. It is for such engineers that this book has been prepared. It carries a sub-title, "What to Read and How to Write with Suggested Information on Allied Topics." This explains the general scope of the work. Its author claims that its purpose is fourfold: First, to impress the readers with the value and need of the command of good English. Second, to indicate something of the standards of good engineering literature and the kind of material that is most valuable to the engineer and show him how to collect and arrange this information and prepare it for publication. Third, to aid the engineer in selecting and reading his professional literature. And, fourth, to collect and preserve some of the information given in the writing and addresses of technical men on this subject. Mr. Frost was formerly editor of the Engineering Digest and manager of the Engineering News Book Department, and thus fully appreciates the need of a book of this kind. With his fund of knowledge of this subject and understanding of the exact points wherein engineers in general lack this knowledge, he is eminently fitted for preparing the work of this kind, which is of real practical value.

## COMMUNICATIONS

### STRENGTH OF LOCOMOTIVE BOILERS

[EDITOR'S NOTE.—Two criticisms have been received touching on the statement concerning the area to be used in calculating the strength of crown stays as given in connection with Fig. 3 on page 127 of the March, 1914, issue, in the article on the "Strength of Locomotive Boilers." The article states that the area at the crown sheet or lower end of the stay should not be considered. In the original copy of the article the author stated that the area supported at the crown sheet end should be the area considered. A difference of opinion arose regarding this statement and it was changed to read as shown on page 127. It was understood at the time that this change had the approval of the author; it appears, however, that this was not the case, and while there may still be differences of opinion as to which method should be followed, we are glad to make this correction.]

A typographical error occurred on page 125 in the same article in connection with the formula  $\frac{(1.13)^2}{D}$ . The brackets should enclose the entire formula, which should read  $\left(\frac{1.13}{D}\right)^2$ .

Some further criticisms of methods used in this article have been received from W. R. Van Housen, St. Paul, Minn. These criticisms with the author's replies are given below.]

ST. PAUL, Minn., March 21, 1914.

TO THE EDITOR:

Regarding the size of rivets to be used in calculating the strength of seams, a variation in the practice of different locomotive builders should be noted. The various works of the American Locomotive Company have followed the practice of drilling the hole 1/16 in. larger than the size of the rivets as given on the drawings. The Baldwin Locomotive Works have always drilled the hole the size shown on the drawings, the cold rivet being 1/16 in. less in diameter.

The tell-tale hole in the outer end of the firebox staybolts should not be disregarded, as Mr. Allman states, for the reason that a 3/16 in. hole amounts to .0276 sq. in. area, and if considered, the stress will be considerably higher. The outer end of the bolt is where the fracture invariably takes place.

The statement that the ultimate strength of steel plates is based on a stress of 55,000 lb. per sq. in. where actual figures are available is misleading. The government allows the use of actual test figures where available. Standard specifications for boiler steel plate call for a tensile strength of from 55,000 to 65,000 lb. per sq. in. The plate in question might come within these limits, or it might have been found to be either higher or lower and still for some reason have been used in the construction of the boiler. In any case where the test figures are available, they are to be used.

In calculating the area of the unsupported portion of the backhead and front tube sheet, an arbitrary allowance of any fixed distance is open to criticism, as it allows no variation for different boiler pressures or thicknesses of plate. A method which makes allowance for both of these variable quantities is given in Peabody & Miller's "Steam Boilers," and agrees with the Master Mechanics' Association formula of 1895.

It is permissible to consider the area supported by a firebox staybolt as equal to the square of the pitch providing the stays are equally spaced each way. On many boilers this is not the case, and the area is then the product of the horizontal pitch multiplied by the vertical pitch. In all cases the area should be measured on the inside of the firebox.

I disagree with the method of calculating girder stays or crown bars. A fiber stress of 17,000 lb., as assumed, would give a factor of safety of only 2.65 in the crown bar. Prof.

Unwin in his Elements of Machine Design, Part 1, gives a more rational method. Briefly, his conclusions are that for a crown bar with two braces to the roof sheet, one-quarter of its load is carried by each foot resting on the side sheet and one-quarter is taken to the roof sheet by each brace. In the case of a bar with four braces the load would be one-sixth for each. The rivets which hold the braces to the roof sheet are the ones meant by "crown bar rivets, top" on Form No. 4 of the Interstate Commerce Commission.

W. R. VAN HOUSEN.

BALTIMORE, Md., April 9, 1914.

TO THE EDITOR:

Replying to the criticisms of Mr. Van Housen:

Regarding the size of rivets, the article does not go into details concerning the practice of the different manufacturers of boilers. The practice of the American Locomotive Company and the Baldwin Locomotive Works in indicating the size of rivets on their drawings, with which I am familiar, does not have anything to do with the article, as I have called attention to the fact that the size of hole is generally considered to be 1/16 in. larger than the initial size of the rivet, although some practices recently adopted have reduced this to 1/32 in. It would, therefore, be necessary in calculating the efficiencies to use the practice in vogue.

The point raised about the omission of tell-tale holes is questionable. The area of a 3/16 in. hole is so small as compared with the whole bolt, that it is disregarded; in fact, I have never previously known the question to be raised regarding this point. In figures which I have gone over, and which were worked up by two of our largest locomotive builders, the holes were disregarded.

Considering the ultimate tensile strength of the steel plates, I am aware that actual figures can be used when they are available; also that standard specifications for boiler plate as made out by various railroads and other manufacturers employ figures between 55,000 and 65,000 lb. per sq. in. Further, when actual figures are not available, the government requires a tensile strength of 50,000 lb. to be used for steel plates and 45,000 lb. for iron plates. The statement made in the article of 55,000 lb. per square inch as the basis for calculation, is for a matter of uniformity, and while actual figures can be used I do not consider this a matter of great importance, as when a boiler is designed for a certain factor of safety, the designer does not base his calculations on the highest tensile strength allowed under the specifications; on the contrary, he generally uses the minimum, and in my experience I find that the vast majority of the plates run much nearer the minimum specified than the maximum.

The criticism regarding the unsupported area of the back head and tube sheet is open for argument. In fact, there are so many views on this, that I would not like to say positively that Mr. Van Housen was correct or incorrect. The method I have given is one used more generally I believe. Mr. Van Housen quotes an authority (Peabody and Miller's "Steam Boilers"), which is very good. I stated in the article that there is a diversity of opinion concerning the area to be considered as unsupported, particularly on the front tube sheet. I have given a method that is approved by the different state boiler commissions, as well as insurance and casualty companies, and believe it is as nearly correct as any and will give results that are satisfactory.

I am aware that the area supported by the firebox staybolt is variable, and I believe that all who have anything to do with boilers, when calculating the stresses, do not take one or more bolts without giving consideration to the entire area to be supported. When the pitch varies of course the entire area should be taken as a unit and not the area supported by any one stay taken at random. The area should be taken on the water side of the firebox, and not on the wrapper sheet.

Mr. Van Housen's claim that the method of calculating the

stress on girder stays is incorrect, is a rather broad statement and I do not agree with him. I believe he is wrong concerning the fiber stress of 17,000 lb., and he further states that there is only a factor of safety of 2.65, which is not correct. This formula is based on a beam uniformly loaded, supported at the ends; that is, the girders are figured to carry a fiber stress of 17,000 lb., allowing the remaining load to come on the slings connected to the roof of the boiler. In other words, before any load could be transmitted to the slings there would be some deflection in the girder, otherwise, there would be no stress in the slings. The stress of 17,000 lb. is used as a maximum to be allowed in the girder and all above this transmitted to the sling. Of course, when a girder is not supported at the ends, the entire load on the crown sheet would be transmitted through the sling stays.

WM. N. ALLMAN.

QUESTIONS FOR CAR DESIGNERS

PHILADELPHIA, Pa., April 4, 1914.

TO THE EDITOR:

I would like to know the proper method for calculating the bending moment at the corners of the open frame indicated in the accompanying sketch. In the American Engineer, November, 1909, page 434, there is an interesting analysis of the stresses that occur in a steel baggage car, having two door openings on the side. In this particular instance, there is a downward shear on the right hand side of the door opening, and an upward shear on the left hand side. These two shears consti-

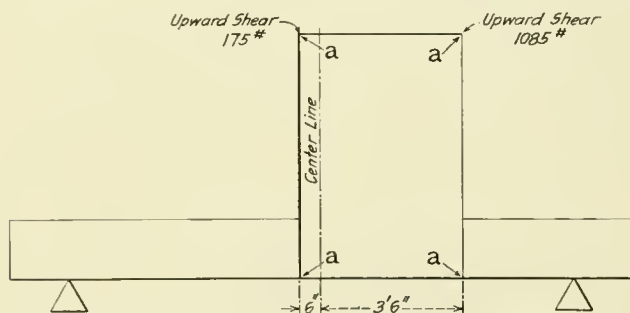

Diagram Showing Stresses at the Sides of the Opening

tute a couple, and the bending moment at the corners can readily be determined; but in the structure represented in the sketch there is on the left hand side of the opening an upward shear of 175 lb., and on the right hand side of the opening an upward shear of 1,085 lb., due to the frame being out of the center of the structure.

Again, if the open frame were in such a position, and the loading were such as to give an upward shear on one side of 500 lb., and a downward shear on the other side of 1,000 lb., how should the bending moments be calculated at the corners?

W. R. N.

TURNING EFFORT OF LEHIGH VALLEY LOCOMOTIVE

RIDGEWOOD, N. J., April 10, 1914.

TO THE EDITOR:

Referring to the article in the March issue of the Railway Age Gazette, Mechanical Edition, describing a Pacific type locomotive, built by the Lehigh Valley, the writer was very much interested in the assertion that the excellent performance of this locomotive is due in large measure to a supposed refinement in the valve gear and valve setting; the remarkable curve of turning effort shown would seem to bear out this statement. A close examination of the drawing, however, does not reveal any radical departure from ordinary practice in the arrangement or application of the Walschaert gear; the valve setting also is identical with present-day practice for high speed passenger



locomotives, with the possible exception of a somewhat longer steam lap.

Being at a loss to account for the extraordinary smoothness of the turning moment curve, the writer determined to investigate the shape of curve that might reasonably be expected from this locomotive. For this purpose the theoretical indicator diagram, Fig. 1, was prepared, to represent the card that this engine would give a speed of 148 r. p. m., or about 34 miles an hour. At this speed the cylinders should develop

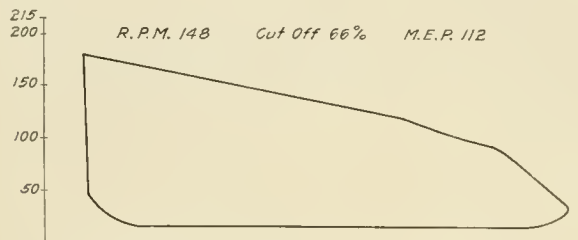

Fig. 1—Theoretical Indicator Diagram

2,300 h. p., assuming that the boiler is capable of furnishing the steam. The horse power is determined by the equation,

$$H. P. = \frac{T. P. \times S \times C}{375}$$

As this engine has a nominal tractive effort at starting of 41,600 lb., the H. P. =  $\frac{41,600 \times 34 \times .61}{375}$

= 2,300. The constant C, for 148 rev. is taken from the bulletin on "Locomotive Ratios" recently issued by the American Locomotive Company. The theoretical card is based on a cut-off of 66 per cent. The drop in pressure at cut-off and the amount of

moment, Fig. 2, was derived, by the method described in G. R. Henderson's "Locomotive Operation," the ordinates representing the successive positions of the crank in one complete revolution of the driving wheels; the abscissae representing the rotating force in pounds, considering the crank arm as unity. The heavy line is the final curve of rotating effort and is the algebraic sum of the steam and inertia forces acting at the crank pin. It will be observed that there is a difference of 47,000 lb. between the minimum and maximum rotating forces, in terms of tractive effort. This represents at the maximum point  $\frac{90,000 \times 28}{77} = 32,700$  lb., and at the minimum  $\frac{47,000 \times 28}{77} = 17,100$  lb. The average rotating force of 69,060 lb. corresponds to a tractive effort of  $\frac{69,060 \times 28}{77} = 25,150$  lb., which checks closely the figure given above.

We must therefore conclude that it is impossible with any type of valve gear or valve setting to produce the curve as illustrated for the Lehigh Valley engine.

In a paper on "The Three Cylinder Engine," delivered by J. Snowden Bell before the Master Mechanics' convention last year, the superiority in turning moment of the three cylinder engine over an equivalent two cylinder engine is discussed and diagrams similar to the above are given, showing characteristic turning moment curves for both types of engines.

H. S. VINCENT.

STEAM TURBINES IN STOCKHOLM.—Two of the most recent types of Oerlikon steam turbines are now running in the central electric station of Stockholm, these being of 10,000 h. p. Turbine and dynamo make up a compact group, and the tur-

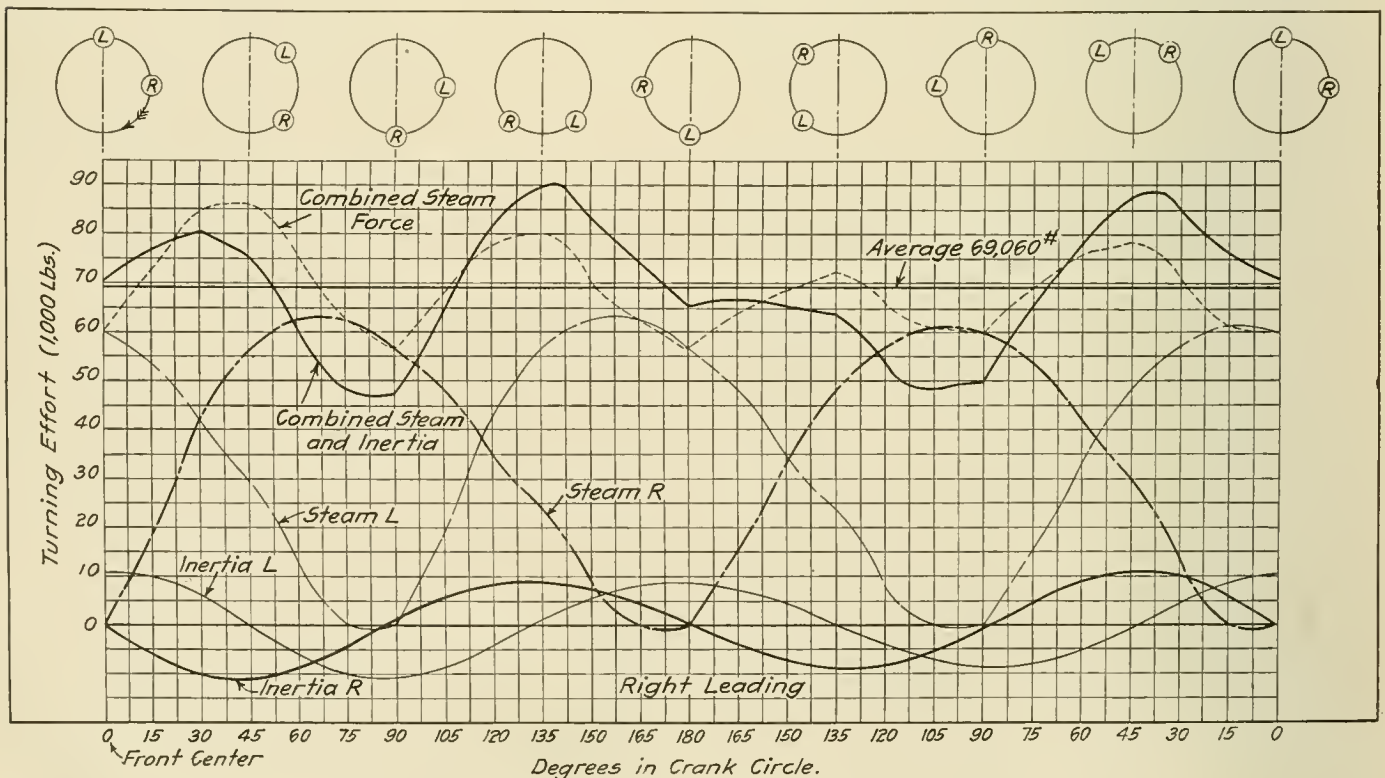

Fig. 2—Curve of Turning Moment for Lehigh Valley Pacific Type Locomotive

back pressure follow closely similar cards from tests of super-heater locomotives on the Pennsylvania Railroad testing plant and tests made in road service. By integration it will be found that this diagram gives a mean effective pressure of 112 lb., or the amount required to produce 2,300 h. p. The normal tractive effort at 34 m. p. h. is  $41,600 \times .61 = 25,375$  lb.

From the theoretical indicator diagram, the curve of turning

biner are of a new design, which is claimed to have a number of advantages, one of these being a steam consumption of 7.9 lb. per h. p. hour. The turbines operate at 3,000 r. p. m. standard speed. Such turbines are made up as usual of blade wheels, each in a separate steam chamber, but the combination of speeds and pressures within the turbine is based on a somewhat novel theoretical design.—Power.

# TRIPLEX LOCOMOTIVE FOR THE ERIE

Largest in Total Weight and Theoretical Tractive Effort; Tender Weight Used for Adhesion

BY R. S. MOUNCE

[WITH AN INSET]

The Baldwin Locomotive Works have just completed a new type of articulated locomotive for the Erie Railroad which marks a distinct step in locomotive construction. It is called the Triplex Compound or "Centipede" type, and, as the name implies, goes beyond the well-known Mallet articulated type by the addition of another pair of cylinders and another group of driving wheels, making three complete engines in one locomotive unit.

The principle of compounding, which involves the use of two high pressure and four low pressure cylinders, originated with and is patented by G. R. Henderson, consulting engineer of the Baldwin Locomotive Works. The design was prepared by that company and incorporates ideas suggested by Wm. Schlafge, general mechanical superintendent of the Erie, who co-operated with them in the various details.

This locomotive is the largest and most powerful ever constructed. The Santa Fe 2-10-10-2 Mallets\*—converted from 2-10-2 freight locomotives—which have up to the present been the heaviest, have a total weight, engine and tender loaded, of 850,000 lb. as against 853,050 lb. for the Erie Triplex. The most powerful locomotives on record, previous to this time, were the Virginian 2-8-8-2 Mallet.† These locomotives have a theoretical

tractable effort, working compound, of 115,000 lb. as compared with 160,000 lb. for the Triplex.

tractable effort, working compound, of 115,000 lb. as compared with 160,000 lb. for the Triplex.

The new locomotive is to be used for pusher service on the eight mile grade east of Susquehanna, Pa., which averages 36 ft. to the mile. Full tonnage trains are now handled over this portion of the main line by a Consolidation lead locomotive with two Consolidations and a Mallet as pushers. The Triplex Compound has a tractive effort equal to the combined tractive effort of the three pushers now used. The capacity of this locomotive is not obtained by using excessive wheel loads or an unusually long wheel base, but is secured by placing the third engine under the tender, thereby taking advantage of a very large weight for adhesion which has heretofore been a dead load requiring considerable power to haul, especially on heavy grades. The wheel arrangement is 2-8-8-8-2 and the total wheel base is 90 ft. The locomotive will operate over curves up to and including 16 deg.

All of the cylinders are equal in size, having a diameter of 36 in. and a stroke of 32 in. Two cylinders are high pressure and four low pressure, the high pressure pair driving the middle group of wheels. The right high pressure cylinder exhausts into a receiver which supplies the front pair of low pressure cylinders,

## BOILER

The boiler has unusually large proportions, exceeding in some respects, especially in its heating surfaces, that applied to the Virginian Mallet type locomotive previously mentioned. The barrel has one conical course. At the front end it measures 94 in. in diameter and at the dome ring 102 $\frac{1}{8}$  in. The circumferential seams are triple riveted; the longitudinal seams have sextuple riveted butt joints welded at the ends, and have an efficiency of 90 per cent. Since the firebox is set over three pairs of 63 in. diameter driving wheels, the throat sheet is quite shallow.

There are 326-2 $\frac{1}{4}$  in. tubes and 53-5 $\frac{1}{2}$  in. superheater flues, 24 ft. long. In order to keep this length within the limits of good practice a combustion chamber 54 in. long is used.

Clearance limits required a very short dome, which is of pressed steel 33 in. in diameter and 13 in. high. In this a Chambers throttle valve is fitted, and is connected to an inside dry pipe in the usual manner. The safety valves are mounted on a steel casting, which is but slightly higher than the boiler

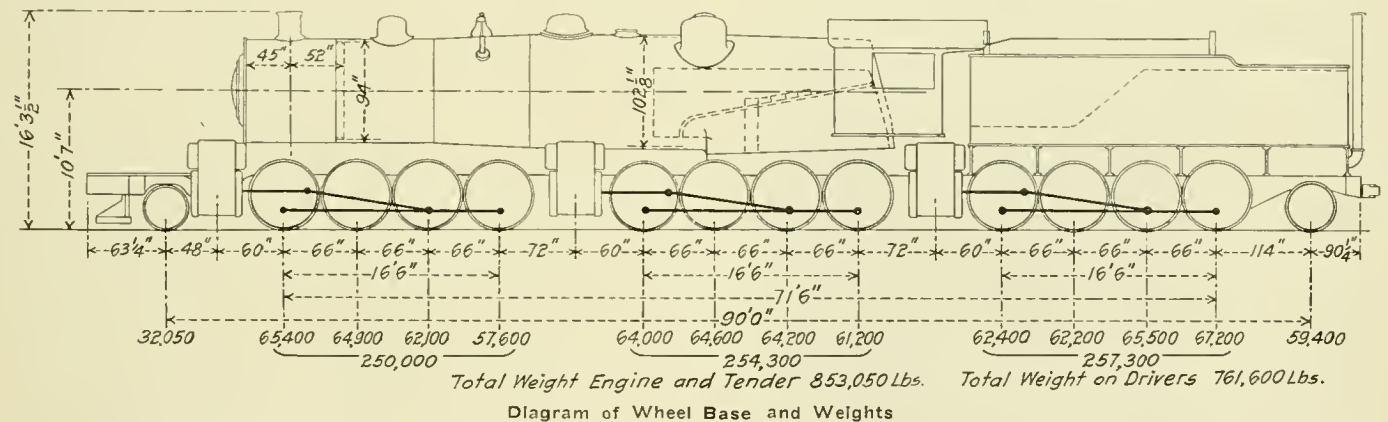

sheil. Instead of one large sand box on top of the boiler, there are two comparatively small ones. Two sets of top boiler check valves are used, one for the injectors and the other for the hot water pumps, which will be described later.

The firebox is of the radial stayed type, with a full installation of Tate flexible bolts. It is 162 in. long and 108 in. wide at the mud ring. The grates extend forward 120 in. to the point where a Gaines brick wall separates the fire space from the combustion space. The brick arch is supported by six 3 $\frac{1}{2}$  in. arch tubes, and is supplemented by the brick wall through which heated air is delivered by seven 3 in. pipes, placed vertically in it. The fire doors are of the Franklin vertical type, two in number, placed 32 $\frac{1}{2}$  in. between centers. The locomotive will be fired by a Street mechanical stoker.

The Schmidt superheated is the largest ever applied to a locomotive, having 53 elements and 1,584 sq. ft. of superheating surface. The header is divided, separate castings being provided for the saturated and the superheated steam.

The front end contains a single exhaust nozzle with a ring type blower. The nozzle is rectangular in shape, and is adjustable, longitudinally, by means of a pair of deflectors mounted on square shafts which are operated from the outside of the smoke box by a right and left hand screw connected to arms on the square shafts. The operating device is located just ahead

\*For description of Santa Fe 2-10-10-2 Mallet locomotives see American Engineer and Railroad Journal, May, 1911, page 171.

†For description of these locomotives see American Engineer, June, 1912, page 287.



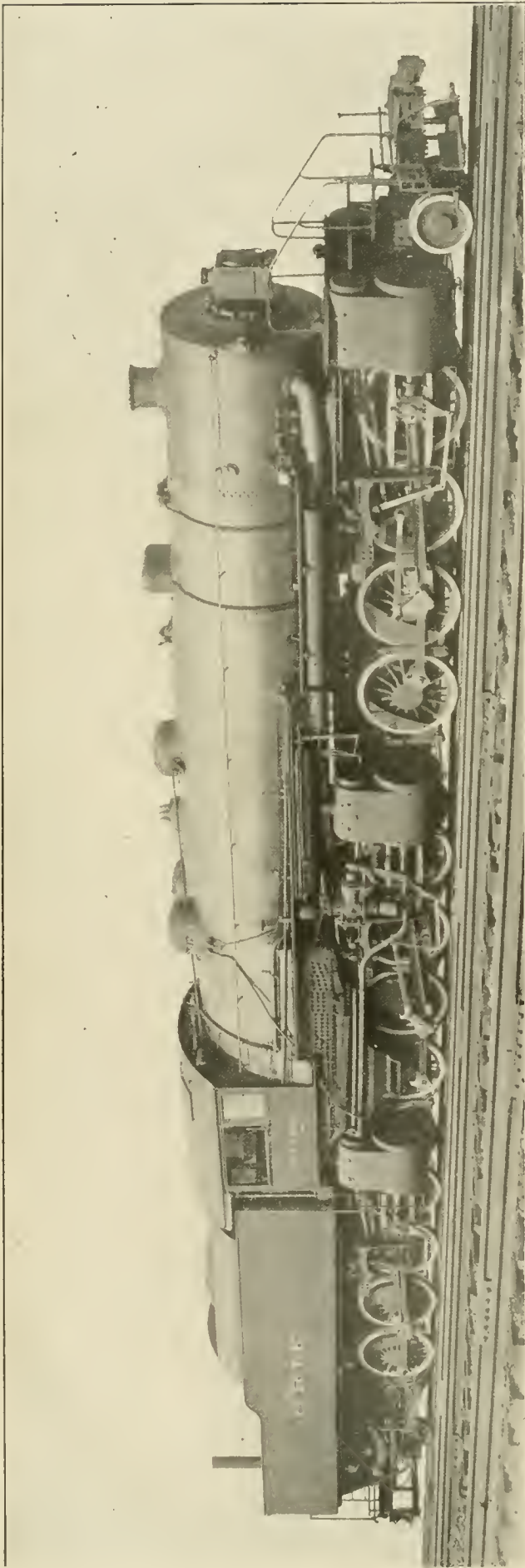

Triplex Locomotive Built for the Erie Railroad by the Baldwin Locomotive Works

of the superheater damper regulator. The nozzle may be varied from about seven by nine inches to seven by three inches. The smoke stack is 22 in. in diameter.

#### STEAM PIPES, CYLINDERS, VALVES AND VALVE GEAR

Steam passes from the superheater to the high pressure cylinders through outside steam pipes, which are fitted with a ball joint and a sliding joint. The high pressure cylinder saddle has two passages cored in it, one leading from the right exhaust chamber to the front receiver pipe, and the other from the left exhaust chamber to the rear receiver pipe. These receiver pipes are flexible, having the usual ball and sliding joints. They convey the high pressure exhaust to the two sets of low pressure cylinders. The front low pressure cylinders exhaust to the stack in the usual manner, through a flexible pipe, whereas the rear low pressure exhaust is carried back the full length of the tender, and is discharged through a vertical pipe at the back end of the tank. Between these cylinders and the exhaust pipe is a feed water heater, which will be described later.

The cylinders are separate from their respective saddles, and are all cast from the same pattern. Cylinders and valve chambers are fitted with Hunt Spiller metal bushings.

The main valves are all 16 in. in diameter, arranged for inside admission, and are driven by the Baker valve gear.

The three sets of valve gear are controlled simultaneously by the Ragonnet power reverse gear. The reverse shaft for the high pressure engine is located just back of the high pressure cylinders, that for the front engine immediately ahead of the same cylinders, and that for the rear engine directly back of the rear cylinders. These shafts are connected by flexible reach rods, the front one passing through the high pressure cylinder saddle, and the rear one through the ash pan and rear cylinder saddle, guides being provided in the saddles and the flexible joint arranged in the form of a rod and crosshead.

#### TENDER AND FRAMES

The arrangement of the tender section of the Triplex is, in many respects, very similar to that of an ordinary steam locomotive. The frames, wheels, driving gear and spring rigging are very much the same as those on the other two sections. The tank is supported on the frames by six cast steel bearers, which act as transverse frame braces as well.

The frames are vanadium steel castings, six inches thick, and, with the exception of those in the tender section, each frame is in one piece, the front portions being a single slab to which the cylinders and saddles are securely bolted and keyed. The rear frames differ from the other four in that they are each in two pieces, the construction usually employed with outside bearing trailing trucks having been followed.

The articulated connection between the middle and front frames gives flexibility both vertically and horizontally. The radius bar is attached to the front frames by a horizontal pin, which provides for the vertical movement. It makes a ball joint connection with the hinge pin under the high pressure saddle. The connection between the middle and rear frames is placed under the cab. It is similar to the other connection, except that the radius bar is rigidly attached to the middle frames, and obtains its flexibility from the ball jointed arrangement at the hinge pin under the rear cylinder saddle.

The spring equalization is arranged as follows:

First engine—The engine truck being of the center bearing type, the equalization is continuous, and the arrangement is like that generally used on Consolidation locomotives.

Second engine—The equalization is continuous on each side without cross connection.

Third engine—The first and second drivers are equalized together, each side independently of the other. The third and fourth drivers are equalized with the trailing truck.

#### FEED WATER HEATER, HOT WATER PUMPS AND INJECTORS

The Triplex locomotive, in addition to its many unusual constructive features, has a novel system of feed water heating and

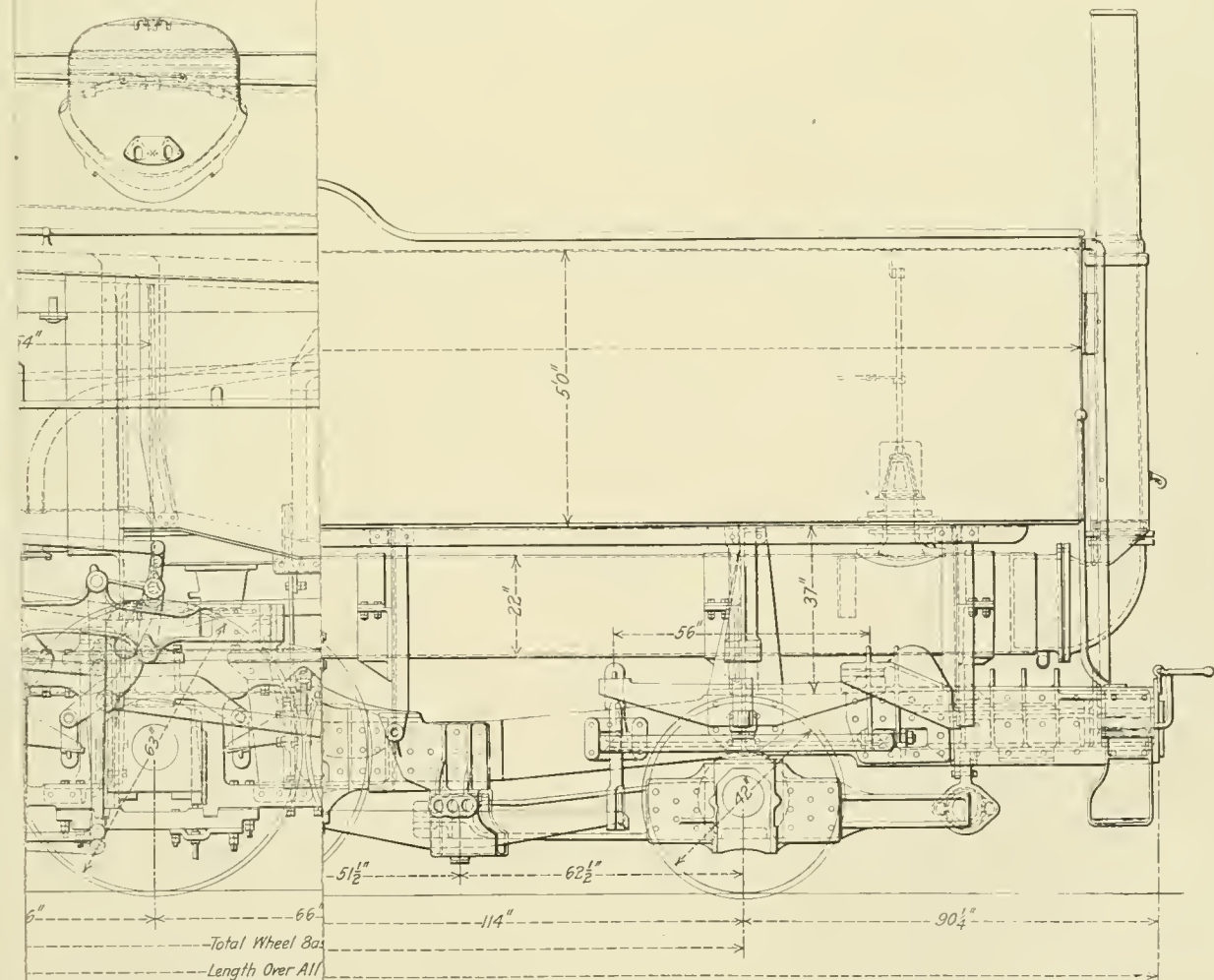
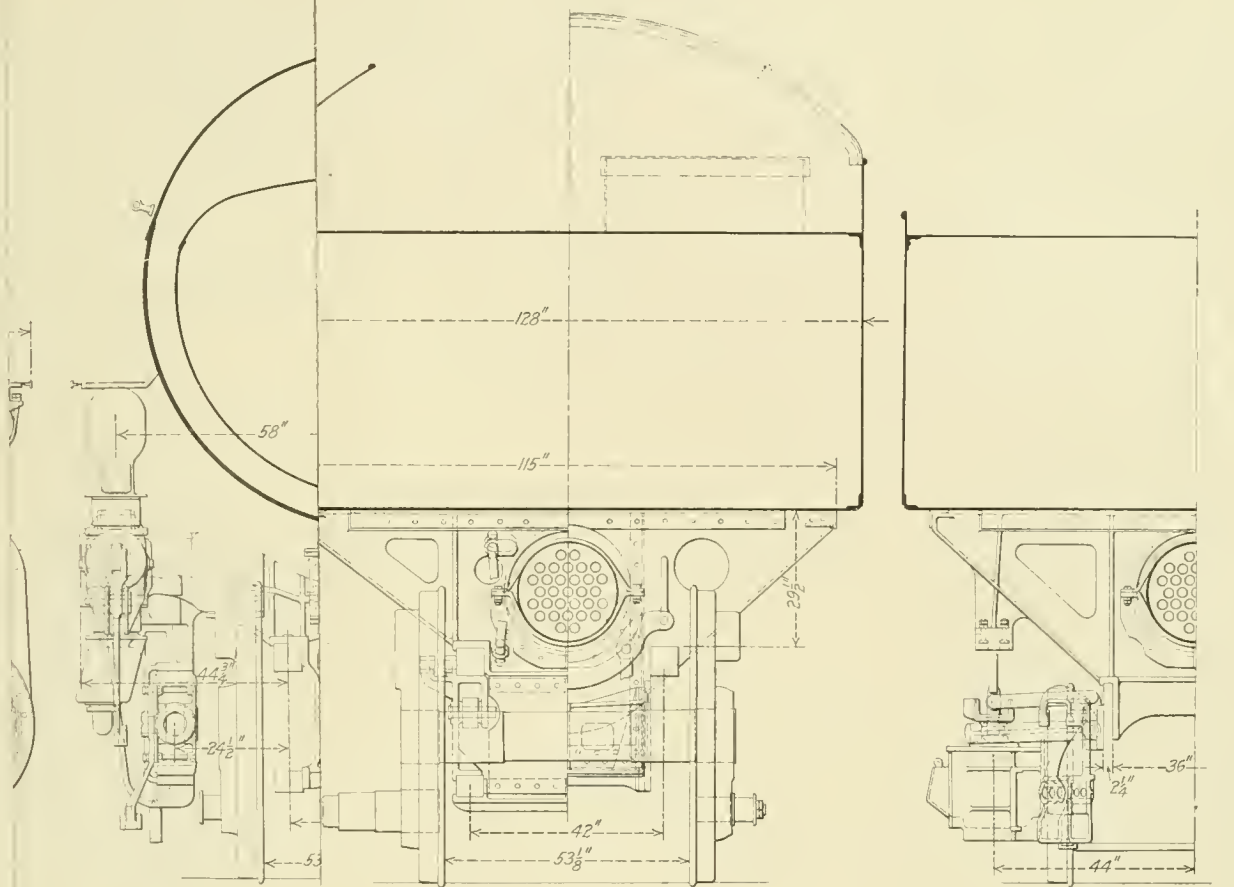



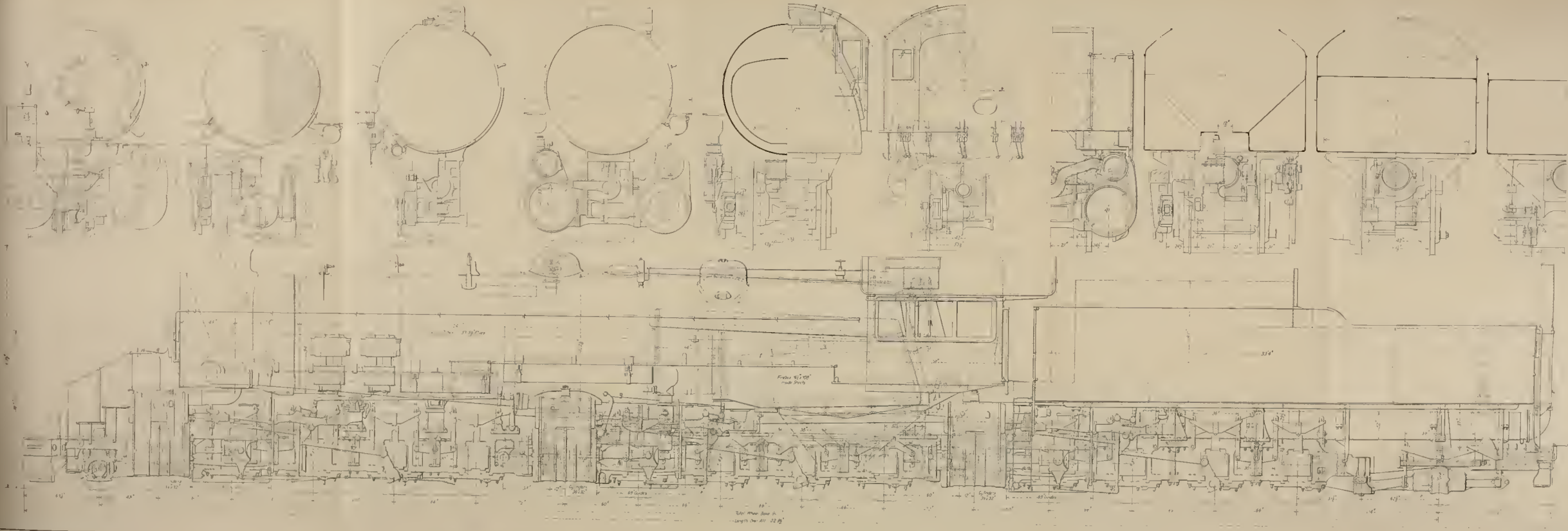

T101A Compound Locomotive Built for the Erie Railroad by the Baldwin Locomotive Works, Total Weight, 85,000 lb.; Theoretical Tractive Effort, 180,000 lb.

boiler feeding. A study of the locomotive ratios might lead one to believe that the locomotive is over-cylindred in respect to heating surface. This, however, should not be the case, because it is intended to supply feed water to the boiler at a temperature not below 200 deg. Fahrenheit.

The feed water heater is a long drum, running longitudinally under the center of the tank. It is 20 in. inside diameter, and contains 31 2¼ in. tubes, each about 24 ft. long. This drum forms a part of the rear low pressure exhaust passage, and is arranged so that the exhaust steam passes through the tubes, giving up some of its heat to the water which surrounds them. The water enters the drum through a special valve at the back end, and leaves at the front end, from which it is fed to the hot water pumps.

The hot water pumps are single acting, and each has one seven inch plunger. The pumps are two in number, one on each side, bolted to the high pressure guide yoke and driven by the crossheads by means of a simple lever, which gives the plungers a stroke of ten inches. The supply of water to these pumps is regulated by a valve in the cab.

The locomotive has two Hancock, type LNL injectors, each of 7,500 gal. per hour capacity. They draw cold feed water from the front end of the tank, and are to be used when the locomotive is not in motion, or if for any reason the hot water pumps are unable to supply sufficient quantities of water to the boiler.

RUNNING GEAR; ASH PAN

The pistons, all of which are alike, have cast steel dished bodies, surrounded by a cast iron bearing ring. Each of these rings has three packing ring grooves, and is secured to the piston by a retaining ring, electrically welded in place. The packing rings, both for the cylinders and valve chambers, are of Hunt Spiller metal.

The driving wheels and rods, valve gear and a number of other details are, as far as it was possible to make them so, interchangeable among the three engines. Many of these parts are also interchangeable with those used on the heavy Mikado type locomotives now in operation on the Erie.

The placing of driving wheels under the firebox, together with the necessity of passing the receiver pipe for the rear low pressure cylinders between the frames, very greatly restricted the space available for ash pan hoppers. It was, therefore, necessary to apply an additional hopper to each side of the ash pan far enough from the driving wheels to clear the driving rods. Ample air space has been supplied, for, in addition to the enclosed side openings provided for in the Talmage ash pan, an opening 60 in. by 8 in. has been cut in the outside sheet of each of the side hoppers, and two openings 12 in. by 12 in. were cut in the front sheet of the main hopper.

LUBRICATION AND OTHER DETAILS

Two Chicago, bull's-eye type lubricators, each with four feeds, are provided for lubricating the valves and cylinders, the steam cylinders of the air pumps, and the stoker engine. The several feeds are distributed as follows: One to each high pressure valve chamber, one to each high pressure cylinder, one to each receiver pipe leading to the low pressure cylinders, one to the air pumps, and one to the stoker engine. In addition to the lubrication supplied to the low pressure cylinders by the exhaust steam from the high pressure cylinders, and by the oil fed into the receiver pipes, small auxiliary static oilers are applied to each low pressure valve chamber.

Flange lubrication is provided for four pairs of driving wheels as follows: First pair of front low pressure engine, first and fourth pairs of high pressure engine, and fourth pair of rear low pressure engine. In every case the feeds are applied behind the wheel. Two Chicago four-feed flange oilers are used for this purpose. All driving boxes are fitted with Elvin lubricators.

The two sand boxes previously mentioned are piped so as to convey the sand in front of the first and back of the fourth pairs of driving wheels of the high pressure engine. There is an auxiliary sand box in the front low pressure cylinder saddle,

which supplies sand in front of the first pair of driving wheels of this engine. For the rear engine a sand box is built around the rear low pressure exhaust pipe at the back end of the tank, and supplies sand back of the rear driving wheels of the third engine. White double air sanders are used throughout.

The starting valve is manually operated, live steam being admitted to the four low pressure cylinders by way of the high pressure exhaust cavities, and thence to the receivers.

Miner friction draft gear, type A-42, has been applied both at the back and front ends of the locomotive. Okadee drain valves have been applied as follows: One in each cylinder exhaust cavity, one in each air pump steam pipe, one in each injector delivery pipe, and one in the blower pipe. Among the specialties which have not been mentioned in other connections are: Air pumps, two New York, No. 5-A; cylinder cocks, Hancock pneumatic; piston rod and valve stem packing, King type; flexible air connections between engine and tender, McLaughlin; headlight, Dressel; water gage, Klinger type; engine truck wheels, solid steel; safety valves, Consolidated.

The efficiency of a locomotive used in slow, heavy service, is largely proportional to the percentage of total weight available for adhesion. In this respect the Mallet Triplex excels all previous designs, having 89 per cent of the total weight of the engine and tender on the drivers. In large Mallets of the 2-8-8-2 type this ratio is not above 65 per cent. This gain is the result of using the weight of the tender for adhesion.

The general dimensions, weights and ratios are given in the following table:

<i>General Data</i>	
Gage	4 ft. 8½ in.
Service	Pusher
Fuel	Bituminous coal
Tractive effort, compound	160,000 lb.
Weight on leading truck	32,050 lb.
Weight on first group of drivers	250,000 lb.
Weight on second group of drivers	254,300 lb.
Weight on third group of drivers	257,300 lb.
Weight on trailing truck	59,400 lb.
Total weight on drivers	761,600 lb.
Total weight of engine and tender in working order	853,050 lb.
Wheel base, driving, each group	16 ft. 6 in.
Wheel base, total driving	71 ft. 6 in.
Wheel base, total engine and tender	90 ft. 0 in.
<i>Ratios</i>	
Weight on drivers ÷ tractive effort	4.76
Total weight ÷ tractive effort	5.33
Weight on drivers ÷ total weight of engine and tender	.89
Tractive effort × diameter of drivers ÷ total equivalent heating surface*	1,088.32
Total equivalent heating surface* ÷ grate area	102.91
Firebox heating surface ÷ total equivalent heating surface*, per cent.	4.12
Weight on drivers ÷ total equivalent heating surface*	82.23
Total weight ÷ total equivalent heating surface*	92.10
Volume of equivalent simple cylinders, cu. ft.	51.32
Total equivalent heating surface* ÷ volume of cylinders	180.48
Grate area ÷ volume of cylinders	1.75
<i>Cylinders and Valves</i>	
Diameter and stroke—2 H. P. and 4 L. P.	36 in. by 32 in.
Kind of valves	Piston
Diameter of valves	16 in.
Type of valve gear	Baker
<i>Wheels</i>	
Driving, diameter over tires	63 in.
Driving, thickness of tires	3½ in.
Driving journals, diameter and length	162 in. by 13 1/16 in.
Engine truck wheels, diameter	33½ in.
Engine truck journals	6 in. by 12 in.
Trailing truck wheels, diameter	42 in.
Trailing truck journals	9 in. by 14 in.
<i>Boiler</i>	
Style	Conical
Working pressure	210 lb.
Outside diameter of first ring	94 in.
Firebox, length and width	162 in. by 108 in.
Firebox plates, thickness	3/8 in. and 5/8 in.
Firebox water space	F., 6 in.; S., 5 in.; B., 5 in.
Tubes, number and outside diameter	326—2½ in.
Flues, number and outside diameter	53—5½ in.
Tubes and flues, length	24 ft.
Heating surface, tubes	6,418 sq. ft.
Heating surface, arch tubes	88 sq. ft.
Heating surface, firebox and combustion chamber	380 sq. ft.
Heating surface, total	6,886 sq. ft.
Heating surface, superheater	1,584 sq. ft.
Heating surface, total equivalent*	9,262 sq. ft.
Grate area	90 sq. ft.
<i>Tender</i>	
Water capacity	10,000 gal.
Coal capacity	16 tons

\*Total equivalent heating surface = evaporative heating surface + 1.5 times superheating surface.



TESTS OF SUPERHEATER PERFORMANCE\*

BY G. D. YOUNG

Engineer of Tests, Pennsylvania Railroad, Altoona, Pa.

The superheater used in the tests recently made on the Pennsylvania testing plant at Altoona was a Schmidt superheater of the fire tube type, or an altered form of it. The normal, or what is called in this paper the standard superheater, consists of tubes arranged in groups or elements and located in large flues in the boiler. There were 32 elements in the locomotive used in the tests.

Each superheater element is made up of four seamless steel tubes having an outside diameter of 1 7/16 in. and a thickness of 0.148 in., all connected by cast steel return bends to form a continuous tube or loop. The steam from the boiler enters the header in the smokebox, then flows into one of each of the 32 superheater elements, passing twice through the hot gases which surround the elements; that is to say, the steam flows to the firebox end of the boiler and then returns to the smokebox end and again flows back to the firebox end and

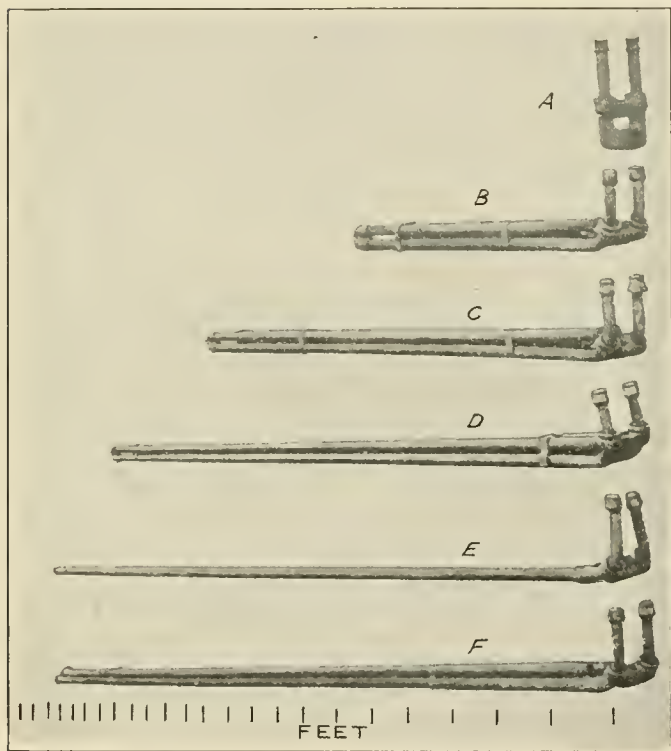

Fig. 1—Superheater Elements

Special or altered forms: A, short returns at header; B, 1/4 length, 4 ft. long; C, 1/2 length, 9 ft. long; D, 3/4 length, 14 ft. long; E, single pass, 19 ft. long; F, single pass dummy returns, 19 ft. long.

finally to the superheater header, entering a part of the header partitioned off to receive superheated steam. The steam then passes directly to the cylinders. This and similar arrangements are called in this paper "two-pass" superheaters. The superheater elements are connected to the header by a ball-joint connection, the ends of each element being drawn up to the header and held in place by a single bolt.

In order to obtain different degrees of superheat without in any way changing the water-heating surface of the boiler or the engine conditions, different forms of superheater elements were used, maintaining the same superheater header and large flues. The details of the arrangements are indicated in Figs. 1 and 2. One element of the standard superheater is shown at H in Fig. 2.

In Fig. 1, A is simply an element at the header of which it might be said that when all of the elements are in place they form a smokebox superheater; B is a quarter-length superheater. The superheater C is one-half length and D three-

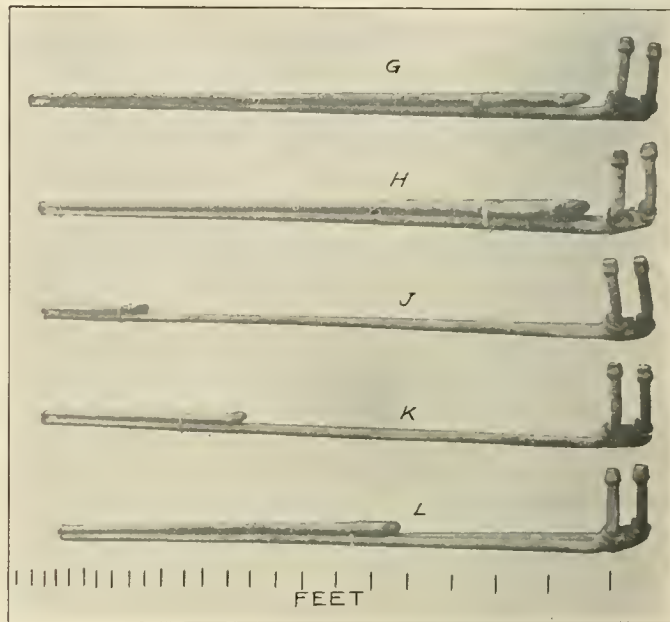

Fig. 2—Superheater Elements

The standard and special or altered forms; G, extra length, 20 ft. 5 in. long; H, standard, 19 ft. long; J, 1/4 return, 19 ft. long; K, 1/2 return, 19 ft. long; L, 3/4 return, 19 ft. long.

quarter length; E and F are of the same length as the standard, but of one pass; F, however, has additional pipes representing the second pass, but having no steam flowing through

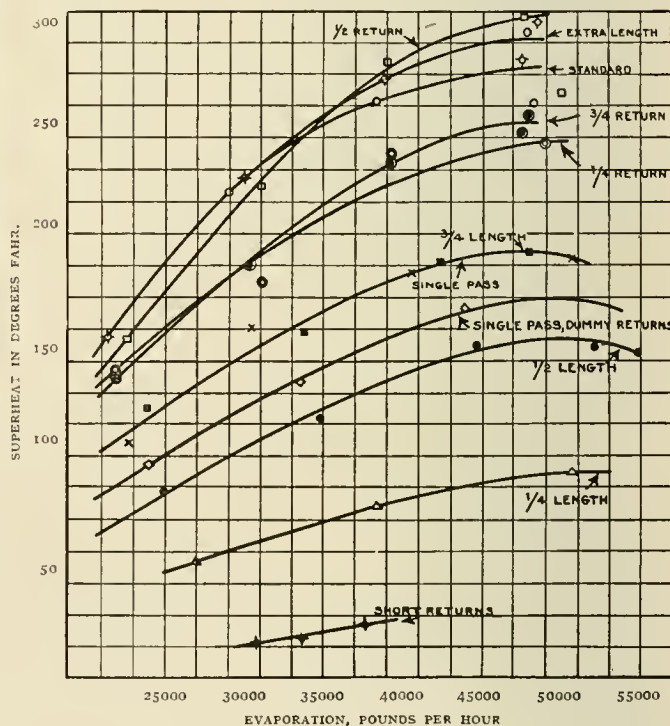

Fig. 3—Superheat and Evaporation

The superheat increases with an increase in evaporation up to 50,000 lb. per hour. Above this evaporation there appears to be a falling off in superheat, probably due to the heavy fire that must be carried, and the fact that all of the coal fired is not being burned.

them. These dummy pipes were used with this single-pass superheater to make the gas passage around the elements the same as with the standard arrangement. In Fig. 2, G is ar-

\*From a paper read before the Franklin Institute, Philadelphia, April 30, 1914.

ranged in the same way as the standard, except that it is 17 in. longer for both passes, whereas *J*, *K* and *L* are similar to the standard arrangement *H*, excepting the return portion which has a length one-quarter, one-half, and three-quarters

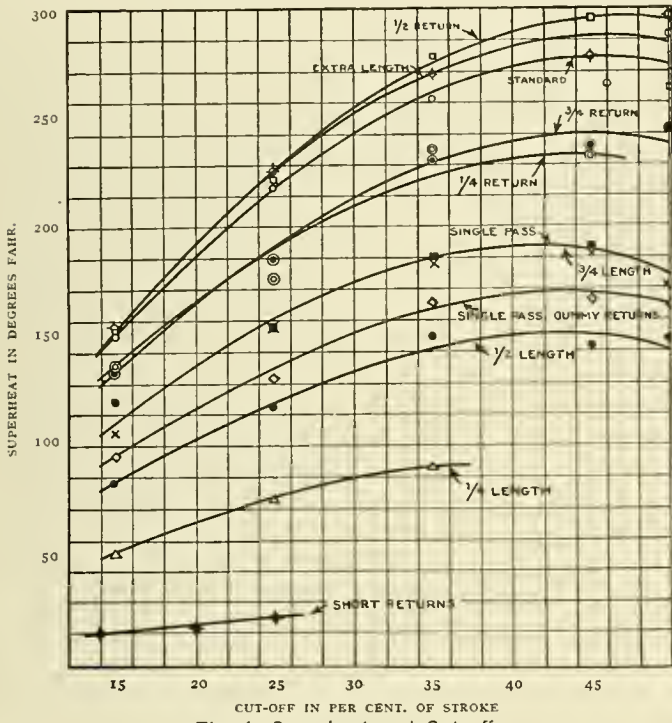

Fig. 4—Superheat and Cut-off

The superheat increases with the cut-off up to 45 per cent; beyond 45 per cent there is a falling off in superheat.

that of the corresponding part of the standard superheater. In addition to the foregoing, the superheater of the three-quarter length arrangement of double-pass superheater had twisted plates inserted in the tubes of the superheater elements,

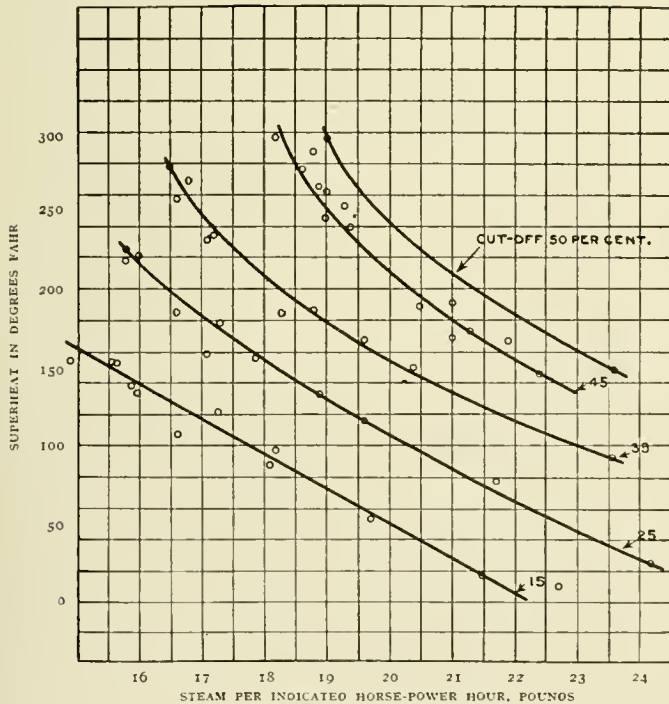

Fig. 5—Cut-off and Steam per Indicated Horse Power

the object being to cause a whirling motion of the steam so that its heat-absorbing action might be improved.

One locomotive was used for all of the superheater tests; it was a class K2sa Pacific type passenger locomotive of the

Pennsylvania Railroad with a brick arch in the firebox. A complete efficiency test of this locomotive, when equipped with the standard form of the Schmidt superheater, was made before the special superheater tests were undertaken and the results are given in full in bulletin No. 18, "Tests of a Class K2sa Locomotive,"† where a further description and drawings of the locomotive are shown.

METHOD OF CONDUCTING TESTS

With each of the superheater arrangements, where it was possible, six tests were run, each having a length of one hour and a half, the cut-offs being 15, 25, 35, 45 and 50 per cent, except where the longer cut-offs could not be maintained. With some of the superheaters one test was made at a speed of 120 r. p. m., or 28 m. p. h., while all of the other tests were made at a speed of 240 r. p. m., or 57 m. p. h. Thus the variable of speed of the locomotive was largely eliminated, and it may be generally assumed that the tests were all made at 57 m. p. h. The steam temperature was measured by means of a mercury thermometer inserted in a well in the steam passage of the cylinder saddle, at a point where the steam is entering the steam

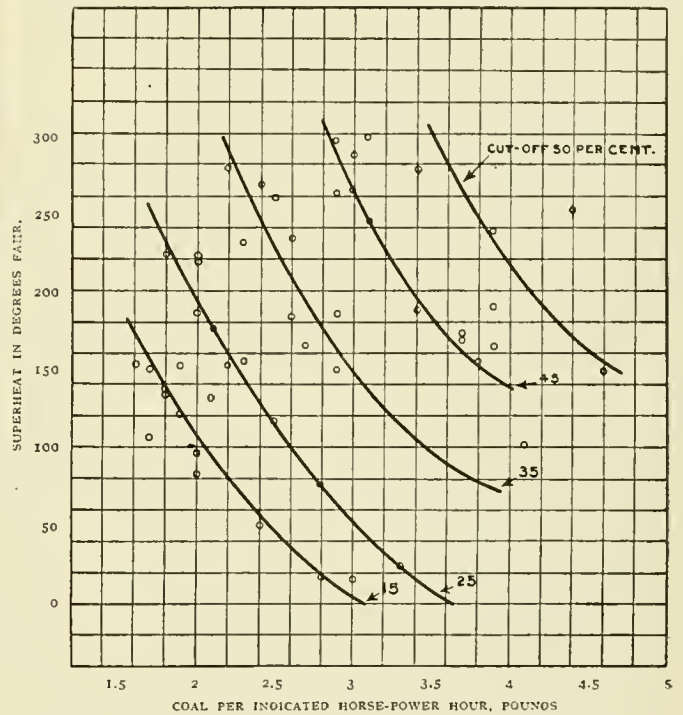

Fig. 6—Superheat and Coal per Horse Power

chest. The steam pressure was observed at this point and at the dome of the boiler by means of steam gages.

During the course of the tests the superheater elements were very carefully blown out with air at the end of each day.

While the tests were of one hour and a half in length, they have been recorded in the tables to appear as two tests, one of an hour duration and one of an hour and a half. It will be noted that the average for the latter part of the test or the last 60 minutes was, in most cases, slightly higher than for the longer time, for the steam temperature and superheat tend to rise slowly for perhaps three-quarters of an hour after the start of the locomotive (see graphical logs of tests, Figs. 12 and 13, for illustration of this effect). This effect may be due to the condition of the fire. The firebox temperature appears to increase during the whole time of a test run. At any rate the results for the latter part of the total time have been used in plotting all of the diagrams.

With the complete superheaters, such as the standard, the half-return, etc., the superheat, a few minutes after starting,

†Copies of this bulletin may be had upon application to the general superintendent of motive power, Pennsylvania Railroad, Altoona, Pa.



is high. At the beginning of one test the superheat was 228 deg., and it increased only 26 deg. during the one and one-half hours of running. In another test, with the half-return superheater, the superheat at starting was 240 deg., increasing 38 deg. to 278 deg. at the end of 90 minutes of running.

To obtain a range of superheat, superheaters of the full-length, three-quarter, one-half, one-quarter length and the short returns at the header were used. It was not expected that the shortened superheaters would develop an arrangement suitable or desirable for use in regular service; the only purpose in using them was to obtain wide variations in superheat.

RESULTS OF TESTS

*The Effect of Different Degrees of Superheat.*—The evaporation and superheat for all of the superheater arrangements are shown in Fig. 3, and an evaporation between 21,000 and 55,000 lb. per hour was obtained, the superheater consisting of short returns at the header, and having a heating surface of about 50 sq. ft. as compared with the standard, which has a heating surface of nearly 1,000 sq. ft., evaporates about 31,000 lb. of water per hour, and has an indicated horse power of 1,425,

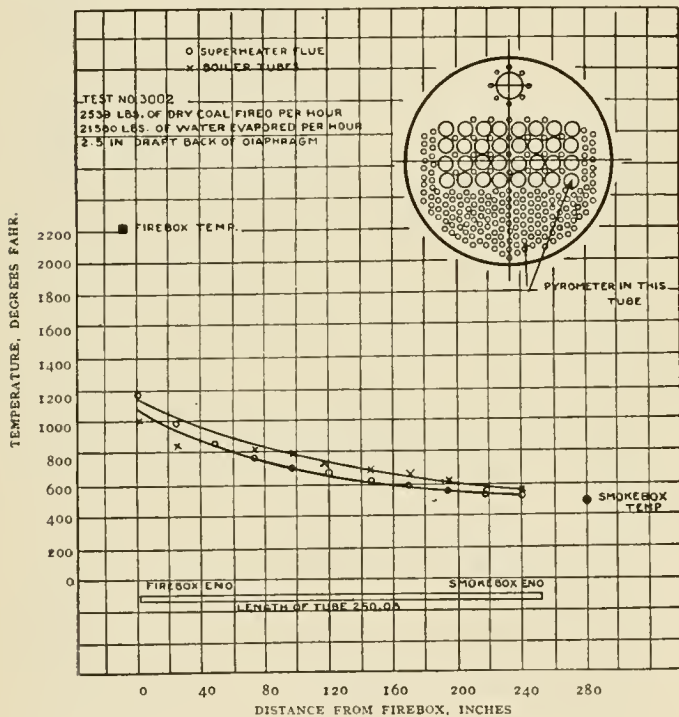

Fig. 7—Temperatures in the Superheater Flue and Boiler Tube

where, with the same cut-off and one of the extra-length superheaters, the evaporation is only about 21,000 lb. for this indicated horse power. This effect is caused by the small superheat obtained with the short returns, requiring a greater weight of steam for the power produced. We find further that this small superheater will not evaporate more than 37,600 lb. per hour or but 70 per cent of what the half-length superheater is capable. The small capacity of this header superheater is brought about by the fact that it does not extend into the large flues in the boiler. With these large flues open or unobstructed by the superheater elements, the boiler does not steam properly, the draft action is unchecked, and holes are made in the fire by the violent agitation of the draft. With the standard steam boiler, having all of the tubes of a small size or with the superheater boiler having the superheater elements in the large flues, the draft pulsations are smoothed out and the fire is not so violently agitated. The small superheater gives a maximum superheat of but 26 deg.

The superheaters of one-quarter, one-half, and three-quarter length show a regular increase in superheat produced, with the

increase in length of superheater. The one-quarter length produces a maximum superheat of 90 deg., and the three-quarter length a maximum of 190 deg. It is also shown by Fig. 3 that as the superheat is increased, the evaporation, when running

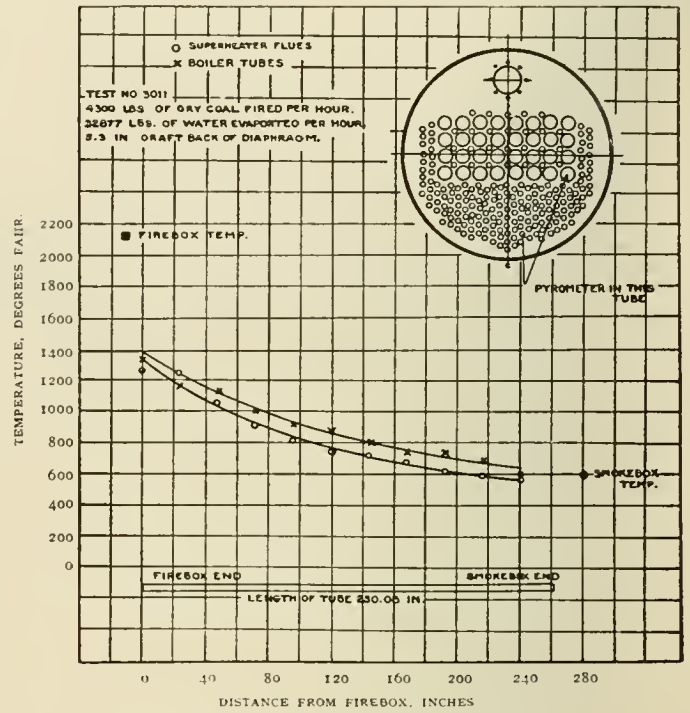

Fig. 8—Temperatures in the Superheater Flue and Boiler Tube

at a short cut-off, is decreased, and further, that the one-half length superheater gives the greatest evaporation that was obtained with any of the superheaters, about 55,000 lb. per hour. There would seem to be a best superheater length or area for

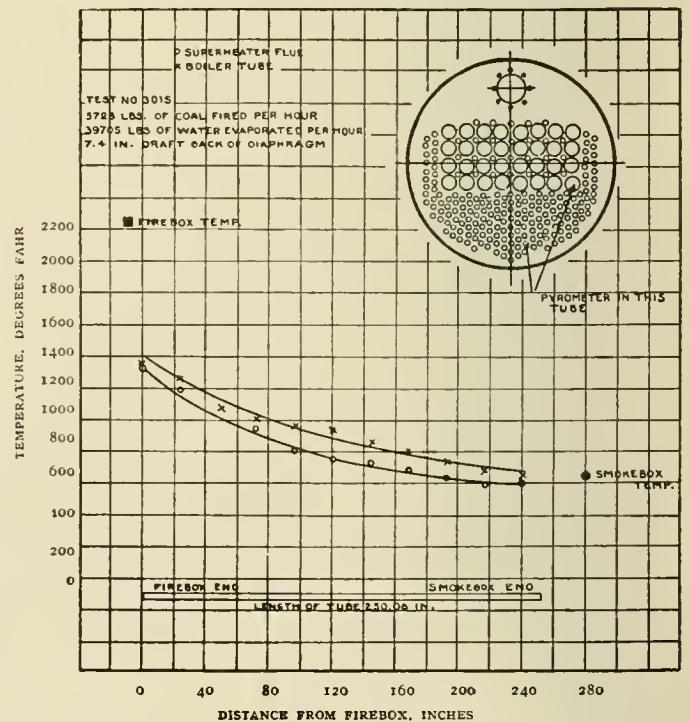

Fig. 9—Temperatures in the Superheater Flue and Boiler Tube

maximum evaporation, but it must not be understood that this superheater, which is best for evaporation, gives the maximum horse power.

The extra length shows a higher superheat than the standard

length, but there might be difficulties in the use of this long superheater where the ends come within a few inches of the firebox end of the flue, and the one-half return gives fully as much superheat; there would seem to be no advantage in the extra length, with the disadvantage of increased friction due to the longer steam passage.

Referring now to Fig. 4, which shows superheat and cut-off, we find that the superheaters arrange themselves in very nearly the same way as in Fig. 3, and this is to be expected because, on account of the constant speed, the evaporation is dependent almost entirely on the length of cut-off.

Considering now the economy resulting from the superheat we have in Fig. 5 the cut-off and steam per indicated horse power. This diagram expresses graphically the essential facts

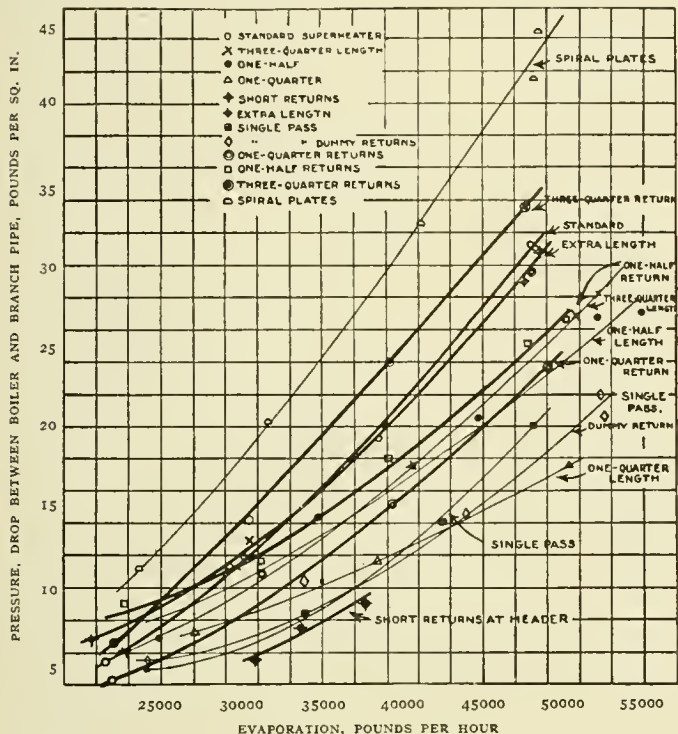

Fig. 10—Loss in Steam Pressure Between Boiler and Cylinders

The superheater with spiral plates in the tubes shows the greatest loss in pressure, while the short superheater consisting of short returns at the header shows the least loss.

for which the experiments were made, and gives for the first time authentic data upon the economy due to superheat unobscured by other variables.

The points of this diagram do not indicate the arrangement of the superheater, but show the effect of both the superheat and cut-off on the economy in steam. We find from the diagram, which shows a superheat ranging from zero, or practically saturated steam, up to 300 deg., that for every increase in superheat, at every cut-off, there is a saving in steam, and that at 15 per cent cut-off, at the speed of these tests, for every 20 deg. rise in superheat there is a reduction in water rate of one pound per indicated horse power hour. At 50 per cent cut-off this increases to a requirement of about 40 deg. rise for the same reduction in water rate.

With a cut-off of 15 per cent and a superheat of about 70 deg., we can obtain a water rate of 19 lb. per indicated horse power per hour, while if the cut-off is extended to 50 per cent at the same speed, the superheat must be increased to 300 deg., so that the water rate will remain at 19 lb. The very great importance of the length of cut-off is thus apparent, but even with the longest cut-off that is shown the water rate does not reach 24 lb., or what may be called the minimum water rate for saturated steam. It thus appears that superheat always shows a saving in steam if the cut-off does not exceed 50 per

cent. Similar conclusions may be drawn from Fig. 6, which shows the superheat, the cut-off and coal per horse power hour.

Some time before these superheater tests were undertaken a series of efficiency tests with the standard superheater was made with this locomotive, and Figs. 7 to 9 show the temperature measurements in boiler tube and superheater flue made at that time. In Fig. 7 the temperature in the superheater flue is 1,160 deg. at the firebox end, falling to about 540 deg. at the smoke-box end. The steam temperature for this test is 572 deg. It will thus be seen that at about 170 in. from the firebox the steam temperature equals the temperature of the gases, and there would be no gain by extending the superheater return any distance forward of this point. This return portion extends forward to a point 148 in. from the firebox. Figs. 8 and 9 show very similar results in regard to the point where the steam temperature becomes as high as gas temperature. From a consideration of these temperature curves, one reason for the good results from the half-return superheater is made clear.

There is a loss in steam pressure as the steam flows from the boiler through the superheater to the steam chest, and this loss in pressure is shown graphically in Fig. 10. All of the superheaters are shown on this diagram. As would be expected, the superheater having the spiral plates in the tubes shows the largest loss in steam pressure as the steam flows through the superheater. These plates have a retarding effect, and, as shown in other diagrams, the increase in superheat obtained by their use does not overcome the loss in power due to the pressure drop. The short returns show the least drop in pressure, as is to be expected, the passage through the super-

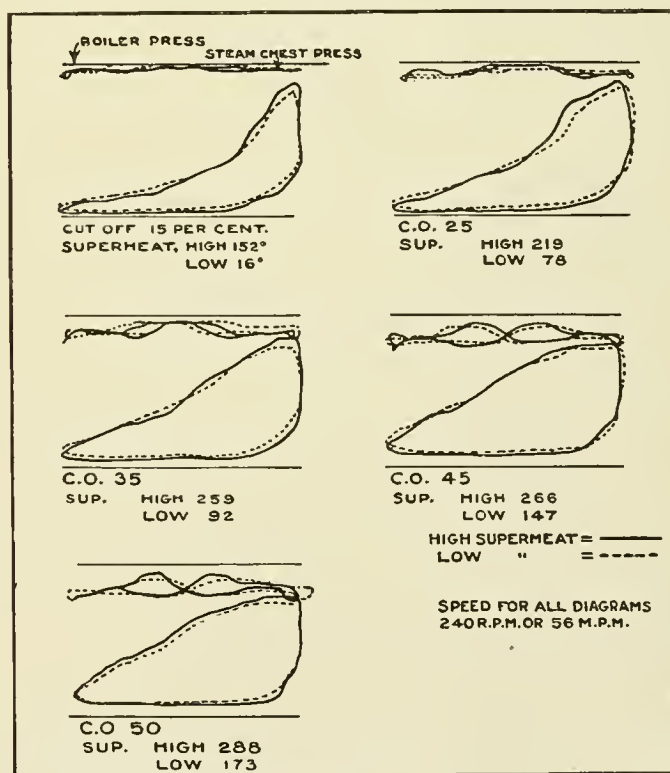

Fig. 11—Indicator Diagrams Showing High and Low Superheat

heater in this case being 25 in. in length. The single-pass superheater shows a little greater drop in pressure, it having a length of 497 in.

Indicator diagrams for high and low superheat are shown in Fig. 11. The first of these diagrams is for a cut-off of 15 per cent. In one case the superheat is 152 deg., and in the other 16 deg., or a difference of 136 deg. There is a drop in pressure between the boiler and steam chest of about 8 lb. The dotted lines are for steam with a low superheat and the full lines for steam with high superheat. During the admission to the cylin-



der the steam having a low superheat shows the lowest pressure during the whole period of admission. During expansion, however, the pressure for the steam of low superheat is higher than for the highly superheated steam. During the return stroke of the piston, while the steam is flowing out of the cylinder, the steam having a low superheat shows a higher back pressure than the highly superheated steam. The same characteristics are evident on all of the diagrams, and the indications are that the highly superheated steam is more fluid or flows more freely into and out of the cylinder than does the steam of low superheat. It was not possible to make a direct comparison of highly superheated and saturated steam, but there are large differences in the superheat in each pair of diagrams.

The results of the tests show conclusively that there is an almost direct relationship between the economy in water and fuel and the degree of superheat, within the range of the experiments. It would be interesting to know how far this general law holds true for a given economical working cut-off. It is seen that if the superheat, at a short cut-off, could be obtained as high as that which was obtained for a long cut-off economies more remarkable than are shown, in steam per indicated horse power hour, would no doubt have been possible. The desirability, therefore, of high-degree superheating for locomotive practice cannot be questioned. Other deductions may be drawn from these tests which, summarized, may be expressed as follows:

(a) The standard superheater now in general use is found

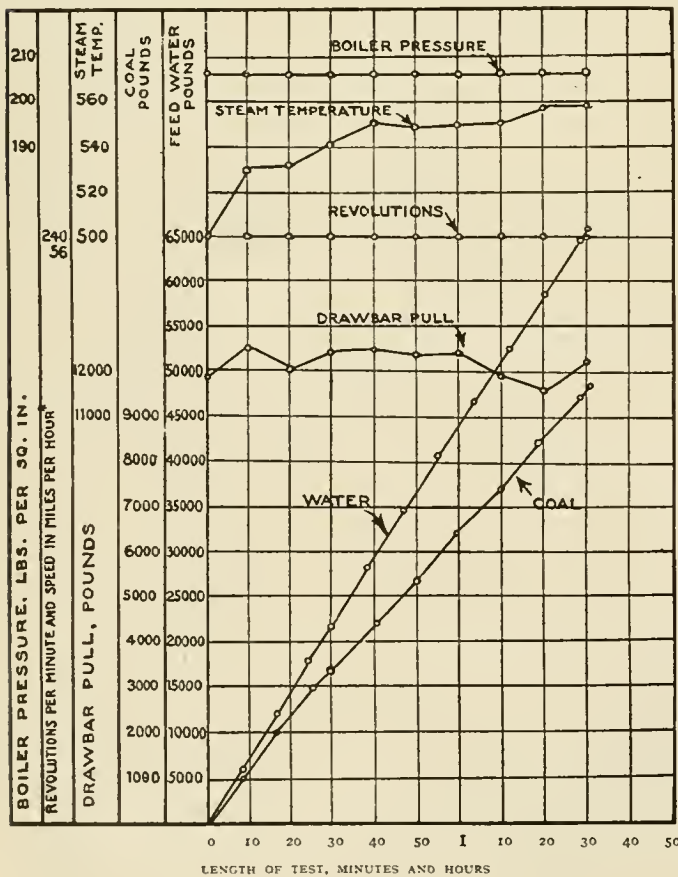

Fig. 12—Graphical Log of Test

to give very satisfactory results with a possibility that some of the return portion could be eliminated with no detriment to the superheat obtained, and with an advantage in cost of material.

(b) Too much importance cannot be attached to the length of superheater; it must extend as far toward the fire as prac-

ticable limitations will allow, considering the life of the elements in the hot gases.

(c) There is an advantage in the return portion of the superheater, but this part may be shortened, to what extent has not yet been finally determined.

(d) As the superheat is reduced, the evaporation of the boiler is increased within certain limits; in other words a boiler without superheater shows a larger maximum evaporation than one with a superheater. The power of the locomotive, however, does not increase with the greater weight of steam produced; on the contrary, the power is reduced with the reduction in superheat.

(e) Within the limitations of these tests, the highest super-

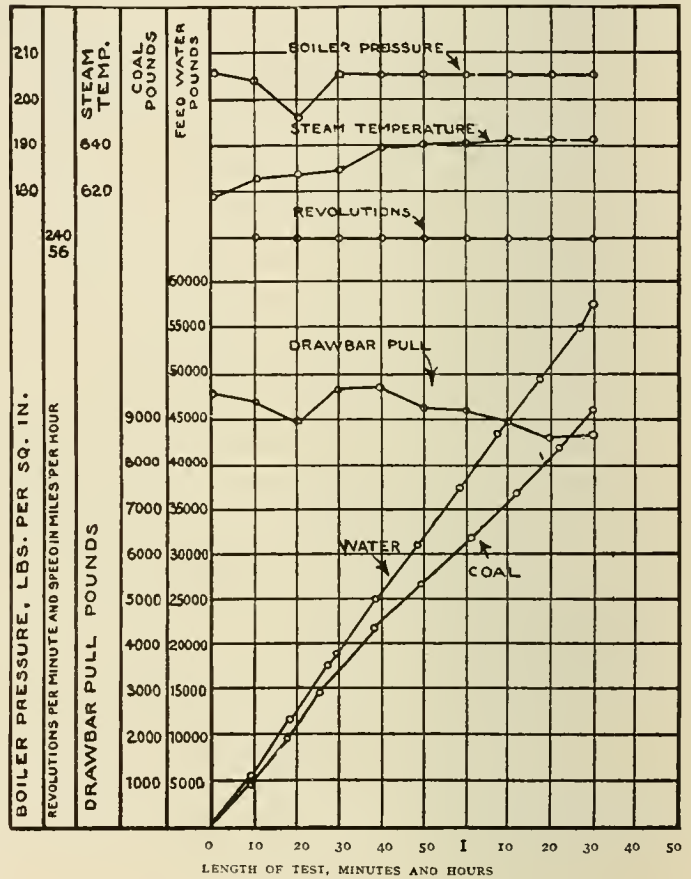

Fig. 13—Graphical Log of Test

heat does not result in the lowest water rate; this is on account of the fact that to obtain the highest superheat the locomotive may be run at an excessively long cut-off, the long cut-off increasing the water rate to a greater extent than is compensated for by the increase in superheat.

Applying now the knowledge obtained from these tests to locomotive practice, it is seen that the advantage of superheating may be utilized in two ways; either in coal and water saved, due to a reduced water rate, or by burning the same amount of coal as would be required in the boiler where it is generating saturated steam and obtaining a decided increase in the power output of the locomotive. If we exclude conditions of starting, this would permit superheater locomotives to haul heavier trains with a saving in transportation facilities and labor.

Another advantage in superheating which only recently is being given consideration, is that, by the application of superheaters small locomotives may be made to haul trains equal to those now hauled by saturated steam locomotives of greater weight, and this means that where traffic has outgrown the locomotive and the right of way conditions not permitting of heavier units of power being introduced, trains may be increased in weight by the adoption of superheaters.

# CAR DEPARTMENT

## WHAT SHOULD BE DONE WITH WOODEN UNDERFRAME CARS?\*

BY CHARLES E. WOOD

Foreman Freight Car Repairs, Union Pacific, Kansas City, Kan.

The recent changes in Rule 120, of the M. C. B. Interchange Rules and the extraordinary conditions which made the change necessary, brought to the attention of car department officers and employees very forcibly the question, "What is to be done with our wooden underframe cars?"

Some roads that seem loath to part with these relics of a pioneer day are, to use a familiar expression, "throwing good money after bad" in attempting to modernize them by equipping them with new appliances, forgetting the old axiom that the strength of a chain is in its weakest link and that in spite of new and improved draft gear or metal roof, the car is still old. The sills, although apparently sound, are dead and brittle, and will not stand the shock which they are subjected to with the heavy locomotives and switching methods now in use.

The writer recently noticed a 34-ft., 30-ton car, bearing the initials of a large eastern line, which was about 20 years old and still had the original wooden body bolsters and short draft timbers. This car had been recently overhauled and equipped with a friction draft gear of the heaviest type, and a new outside metal roof, as well as other repairs representing an outlay of at least \$100. But the car was not fit to go in the head end of a heavy train. There is no doubt that the draft gear was guaranteed to withstand about double the shock that the wooden sills would stand, and the folly of applying this heavy gear to short wooden timbers depending on four or five bolts is self-evident.

Another method is to put "Rough Freight Only" signs on the car and let it run until some unfortunate engineer stops his train too suddenly and breaks it in two. There are several good reasons why this plan is a failure, aside from the above possibility, the main one being that switchmen are a class of men that do not believe in signs. Furnish a switchman with two cars, one boarded as above and the other a new first class steel underframe car, and order him to set one to load scrap iron and the other at the house for merchandise, and anyone knows where to look for the "Rough Freight Only" car. If you mildly suggest that he ought to have set them the other way, you will be told "A car is a car," which is a fact you cannot dispute.

Then we have all seen the car bearing the sign, "Set at rear of train," and it is astonishing how seldom it gets there unless it is after the draft rigging has pulled out. And who has not seen the sign "For Local Service Only," between two points you have never heard of, adorning the sides of a car many hundreds of miles from its home rails?

The only practical way to solve this problem is to set a limit of expenditure on this class of equipment and whether the car is at a home shop or some foreign line is asking for home route cards, when the estimate runs over that amount, dismantle it and be thankful that one more menace to safe train operation and another help toward the high cost of freight car repairs, is disposed of.

One danger where there is a limit of expenditure is that the estimate is based too often on such repairs as are immediately necessary, instead of subjecting the car to a rigid inspection and including all the repairs which would be required to put the car in first class condition. For example, a car may be in a shop and have a side sill renewed and two draft timbers applied, only

to show up a month or so later at another repair point with the roof loose and shifted. The foreman there sees the repairs recently made, and decides that the car is worth a new roof. He can apply one and still come within the limit; but if the first man had used good judgment he would have reported fully the condition of the car and secured proper disposition. This is a matter which should be watched closely, as a great deal of money can be wasted in this way.

The wooden car must make way for its successor, the steel underframe car. The changes in the rules in the last few years show that the Master Car Builders, as a body, recognize this, and the quicker all roads eliminate them, the better it will be for everyone who has anything to do with them, whether shipper, trainman or carman.

## CAR DEPARTMENT ORGANIZATION AND EFFICIENCY\*

BY A. CAREY

At the present time when railroad transportation rates are stationary perforce, and the cost of all material pertaining to railroad operation and maintenance is greatly increased, special effort should be made toward improving shop efficiency. It is the purpose of this article to point out some of the losses, due to defective organization, mismanagement or inefficiency in some particular.

### ORGANIZATION

The first and most essential step toward the highest possible shop efficiency, is intelligent organization of the shop forces. The principal feature of shop organization, and yet one that is perhaps too often lost sight of, is the equitable balancing of forces in the various interdependent departments, in order to prevent a blockade of work in one department which has not its proper quota of men, while the preceding department is oversupplied with help.

A condition such as this is perhaps oftener to be found under the day work plan, than under the piece work system. In fact, it is the piece work system that offers the best possible basis for balancing the forces, because all workmen more nearly exert their best efforts when performing piece work.

The various divisions or subdivisions of work in the different departments bear definite ratio in working units to each other, and unless this ratio is ascertained, and the forces of the various departments proportioned accordingly, there is no means of ascertaining whether the highest degree of efficiency has been attained. On the other hand, when the forces of the various departments are properly balanced, all lost motion will become at once apparent for the reason that in that case, each department would necessarily have to keep step with the others or else expose its own deficiency.

### SYSTEM

A most important feature of shop organization is a good practical working system, not so elaborate as to be fettered with too much red tape, but sufficiently elastic to meet contingencies as they arise, and rigid enough to counteract all lost motion. The absence of some semblance of a working system is as fatal to success as a lack of discipline would be to an army. There is a distinct loss, though it may be small, connected with every operation of shop work unless particular care has been taken to ascertain and eliminate it. The smith who cuts off a piece

\*Entered in the Car Department competition which closed February 1, 1914.

\*Entered in the Car Department competition which closed February 1, 1914.



of iron two inches too long, the machinist who uses a dull chisel, the carpenter who uses a dull saw, the painter who places his bucket in the wrong position, or continues to use a brush that has worn to a mere stub, the upholsterer whose thread is so long as to require two movements of the arm at each stitch to draw up the thread, all constitute small items of loss. In the aggregate, they amount to a distinct loss of not insignificant proportions. A thorough working system will expose and eliminate all such losses.

#### QUALIFICATIONS OF SHOP OFFICERS

Shop efficiency depends mainly upon intelligent shop organization, and competent workmanship wisely directed. No officer can wisely direct his subordinates, or intelligently give needed instructions as to the details of the work, unless he himself is fully competent and keeps informed in the advances being made elsewhere along mechanical lines.

Another qualification essential in a shop officer is the ability to draw out the latent resources of his workmen. It is more advisable in most instances to place a workman more or less on his own resources than to undertake to give detailed instructions covering every stage and every phase of the work. By this means a workman's sense of pride may be stimulated, the foreman is relieved of much detail work, the workman is improving his ability, and the result to all concerned is more satisfactory. As a further means to being a successful foreman, a man should not only be a competent mechanic, but he should also be a student of human nature, broad minded, have a mind of his own, be not easily swayed by religious, political or fraternal influences, but endeavor to deal justly with each employee according to his individual merits.

#### SUPERVISION

The organization of the supervising force in some instances seems to be a haphazard arrangement. One foreman is often required to handle from five to ten times as many men as another foreman. It should be apparent to any practical man that such conditions cannot work out satisfactorily.

A foreman who gives due attention to all the necessary details of his department can handle profitably only a limited number of men. No foreman can either properly conserve his own energies or do justice to his position, who undertakes to go beyond a reasonable limit in this particular. There is no rule for ascertaining the exact limit in such cases; one's own abilities, circumstances and conditions are the determining factors. A larger force, if concentrated, can be handled by one man than in cases where workmen are scattered over a large area. Some companies have found it advisable to increase the supervising force rather than the working force. Imperfect supervision represents one of the largest items of loss to be found in the shop, but can be largely prevented where a co-operative spirit is dominant in the supervising force.

Brute force is always a losing factor in handling men. The foreman who swears at and bullies his workmen, and the foreman who is too passive to administer needed reproof, are the two extremes in supervision, neither of which pays.

Too much supervision, or supervision of the meddling kind, does not make for efficiency; it is a reflection either on the foreman or his workmen. A famous manufacturer once said that he attributed his success to his ability to draw around him the kind of men who knew how to do the things he wanted done better than he could do them himself. It is not to be expected that a foreman will be able in every instance to excel his workmen in every piece of handicraft, but he should have a general knowledge of the work, and the ability to direct it by the shortest route to a successful conclusion.

#### ANTIQUATED MACHINERY

Of the various obstacles to shop efficiency, one of the worst is antiquated machinery which should long since have been replaced with modern machines, capable in many instances of

more than quadrupling the output. The majority of railways have wisely installed modern machinery; but in some instances there is yet out-of-date equipment to be found.

#### CROWDED SHOPS

A costly mistake sometimes made in shop management is that of overcrowding, by endeavoring to perform all classes of car work in the same building. The various shop conditions required in such cases by the different classes of workmen in order to perform their work properly, cannot possibly be obtained at the same time. For instance, the carpenter in warm weather requires open doors and windows, a condition which cannot be considered in the work of the painter during the varnishing and finishing stages of his work. These conditions prevent the free movement of the workmen; ill feeling is sometimes started by encroachments upon each other's work; system and discipline are broken down, and the result is a decreased output of inferior quality.

A separate department for each class of work is essential to economy. One of the larger roads finds it economical to make five transfers of its coaches from shop to shop before reaching the final stage of repairs. While it is true that all shops have not the shop room necessary to handle work in this manner, much improvement along this line is possible in many cases. It is possible that this manner of handling work has obtained so long in some shops, that those responsible for it have deluded themselves into the belief that a change to more profitable methods is impossible, but it is a distinct loss, and a large one.

#### CLEANLINESS AND COMFORT OF WORKMEN

There is nothing that indirectly conduces more largely to shop accomplishment than clean surroundings and comfortable conditions for the workmen. There is nothing so disparaging nor so fatal to a workman's pride as being compelled to work in a dirty, uncomfortable shop. Clean and comfortable surroundings tend in no small measure to the making of careful and capable workmen, and vice versa.

#### SCHEDULING WORK

Some shops do not schedule their output, but this is a matter of importance, and helps in no small degree to increase the total output of the shop. To appoint a definite time for the departure of each car affords each interested workman something definite to work to, and enables him to judge in advance how well (or how slightly) he can perform his part of the work in the time allotted. Scheduling work has about the same effect on workmen as scheduling the departure of a train has on the traveling public.

#### AMPLE AND SUITABLE WORKING MATERIAL

A shop equipped with the most modern machinery, and employing the most approved methods in handling work may even then be operated at a distinct loss unless provided with ample and suitable working material. Some railroad companies have deemed it advisable to operate the storehouse under a management separate from the shop, which was not formerly the custom; but the economy of this plan may be questioned, as the delays in procuring material seem in some instances to be greater than under the former method. There is, however, no apparent reason why this should be so; in fact the contrary should be the case. However, the storehouse is the right arm of the mechanical department, and must have its best support in order to obviate serious loss from that source.

**AUSTRALIAN WHEAT TRADE.**—The Australian minister for lands and agriculture has announced that the government will lose no time in bringing into operation a comprehensive scheme for the bulk handling of wheat. In his outline of what he describes as "an up-to-date, effective, and comprehensive scheme," he says it will include a central elevator in Sydney, one at a northern port not specified, and a third at Jervis Bay.

# CANADIAN PACIFIC STEEL COACH

A Car Which Is 72 Feet Long and Weighs 114,800 Pounds; Unusual Type of Roof Structure Employed

About two years ago the Canadian Pacific designed and built at the Angus shops, Montreal, an all-steel day coach. The car was placed in regular service and results with it have been so satisfactory that there are now under construction at Montreal 12 all-steel baggage and express cars, 25 all-steel first class

sign of steel truck used was described on page 26 of the January, 1914, issue of the Railway Age Gazette, Mechanical Edition.

The distinctive features of the car are cork insulation veneered steel lining, individual truck brakes and a modified arch or turtle back roof that preserves the clerestory effect inside

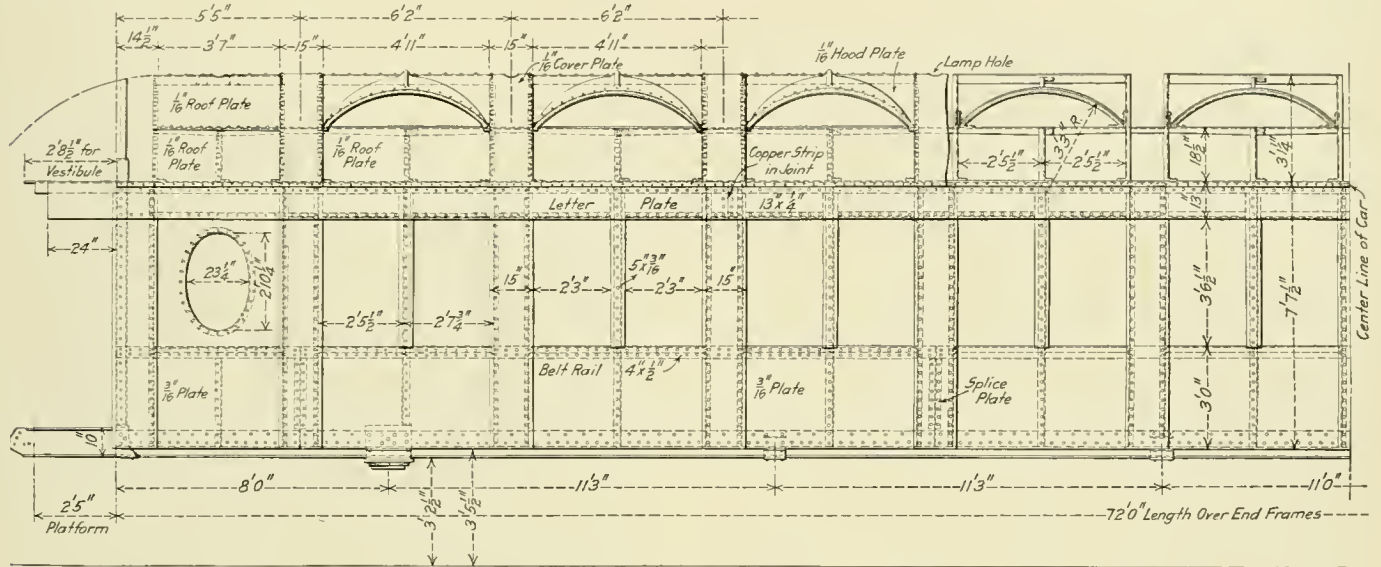

Arrangement of the Side Framing and Sheathing

coaches and 30 colonist cars. These cars will be of a similar construction to that shown in the illustrations. The first class coach, which is shown in the half-tone engraving, is 72 ft. long over the end sills and has a seating capacity for 84 passengers. The light weight on four-wheel trucks is 114,800 lb. The de-

and renders possible the use of deck sash for light and ventilation.

## UNDERFRAME

The center sills are 10 in., 27.2 lb. channels, spaced 16 in. back to back and extend through between the platform end sills. A



Steel Coach In Service on the Canadian Pacific



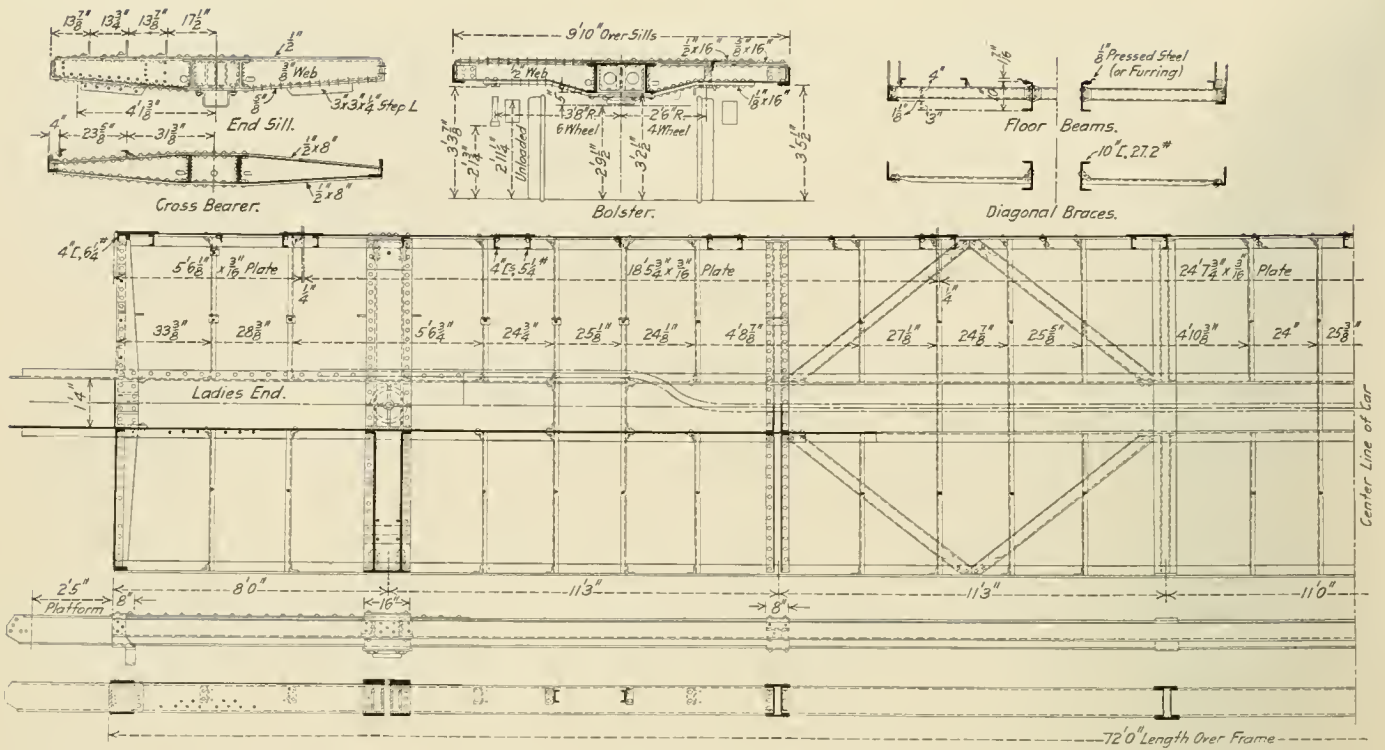

Underframe of the Canadian Pacific Steel Coach

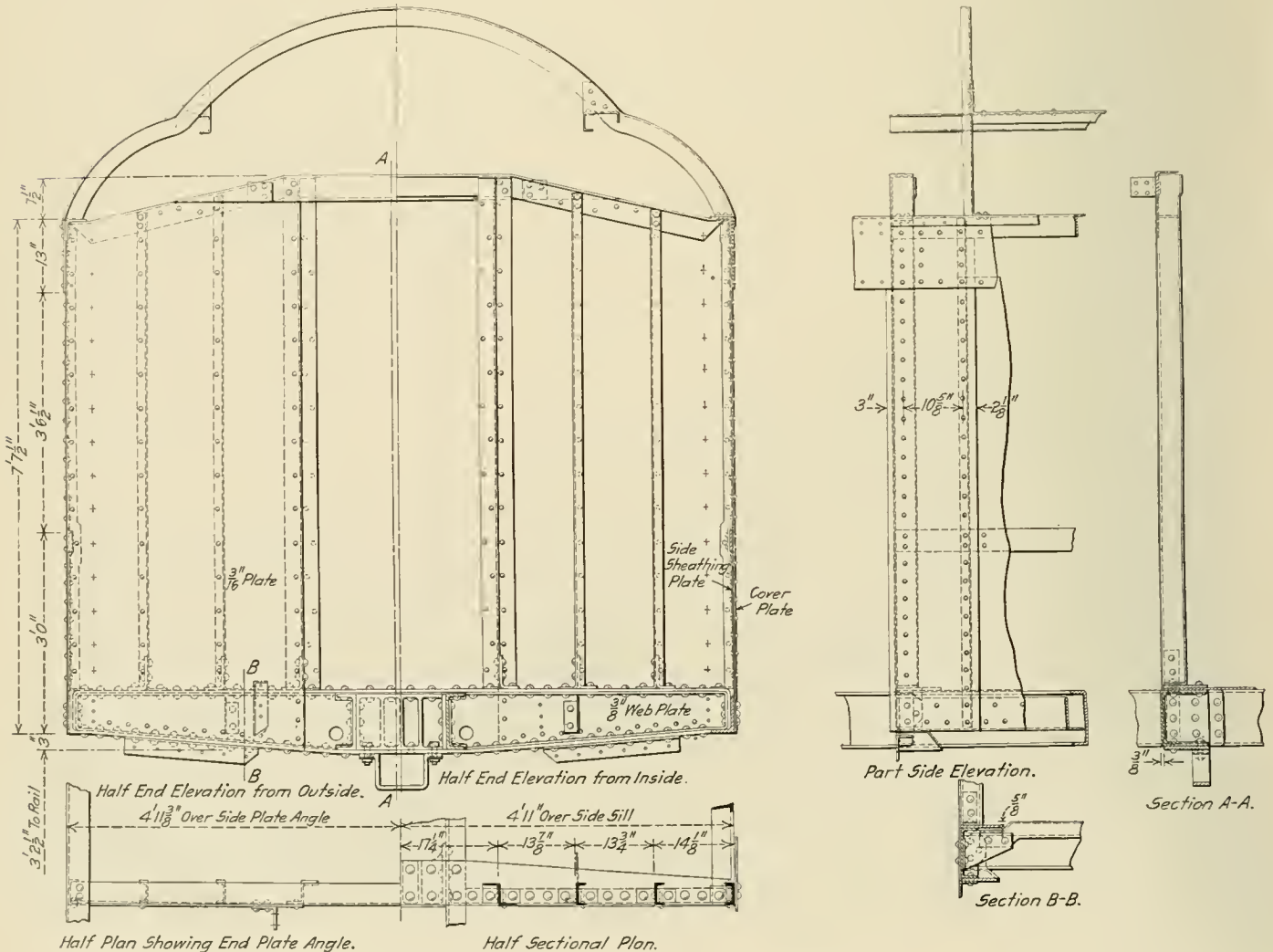

End Construction of Steel Coach on the Canadian Pacific

5/16 in. top cover plate is used, extending from the end sill to a point 18 in. back of the body bolster, and a 1/4 in. bottom cover plate extending between the body bolsters. The side sills are 6 in. by 4 in. by 1/2 in. angles, extending between end sills, and there are four cross bearers built up of 3/16 in. pressed webs and 1/2 in. by 8 in. cover plates.

The body bolsters are built up of 1/2 in. pressed web plates between the center and side sills with a casting between the center sills. A 5/8 in. by 16 in. top cover plate extends the entire width of the car and is turned down at the ends and riveted to the side sills. There is an additional 1/2 in. by 16 in. cover plate, 6 ft. 11 1/2 in. long placed on top of this, the rivets extending through the two cover plates and the flanges of the webs. A 1 1/8 in. by 16 in. plate extends 4 ft. 1/4 in. on either side of the center of the car and is riveted to the center sills and the bot-



Interior of Canadian Pacific Steel Day Coach

tom flanges of the bolster web. The center plate is riveted to this plate.

There are eight diagonal braces consisting of 4 in., 5/4 lb. channels extending from the center to the side sills. Four of these are placed in the form of a diamond between each of the two pairs of cross bearers.

The end sill is composed of 3/8 in. fillers with a casting between the center sills. A 1/2 in. top cover plate extends across the car and is bent down and riveted to the side sills in a manner similar to that used in the bolster. There is also a 5/8 in. bottom cover plate.

SIDE AND END CONSTRUCTION

The belt rail is a 4 in. by 1/2 in. continuous plate and is reinforced between the side posts by 3 in. by 2 in. by 3/16 in. angles. The side posts are 4 in., 5/4 lb. channels, and the corner posts 4 in., 6/4 lb. channels, while the side plate is a 4 in. by 4 in. by 3/8 in.

angle. The end plate is formed of an angle and is horizontal between the two door posts, beyond which it slopes downward slightly to its connections with the side plates. The two inner end

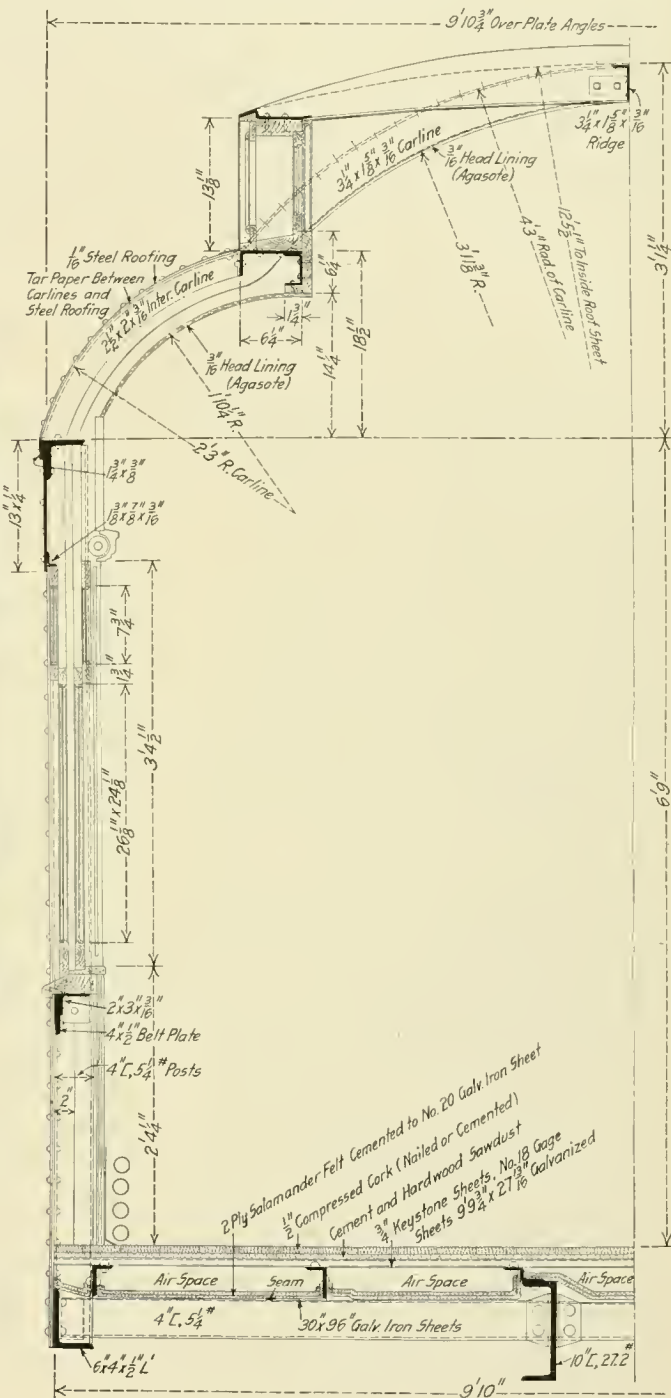

Cross Section Through Canadian Pacific Steel Coach

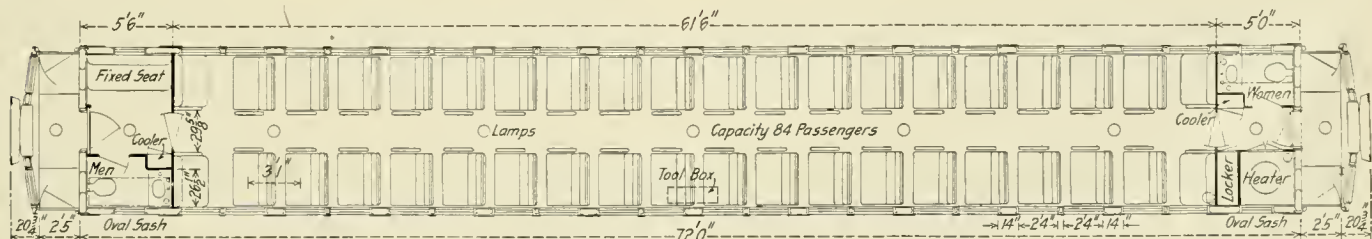

Floor Plan of the Canadian Pacific Steel Coach

posts, or door posts, are heavy Z bars, while there are two intermediate channel end posts on either side of the car. All four of



these posts are riveted at the top to the end plate and at the bottom are riveted to the top of the end sill.

The platform end sill is a built up structure and is connected directly to the ends of the center sills which extend out under the platform. The vestibule door and corner posts are formed of special shapes and are connected to the platform end sill at the bottom and at the top to a channel extending across the car and connected at the ends to the extensions of the side plate angles. Diagonal braces also extend from the top of the vestibule door posts to the car body corner posts at the side plates, and the tops of the vestibule door posts and the Z bar end posts of the car body are connected by short channels. Above the

INSULATION

The insulation has been found to be quite satisfactory and makes the cars equally as comfortable as the wooden cars, even in the most severe winter weather. Directly on the 4 in., 5¼ lb. channels which extend from the center sills to the side sills and form the floor beams, there are placed No. 20 galvanized iron sheets with three-ply Salamander felt cemented to the upper side. Between this and the upper side of the floor stringers, which rest on the floor beams, there is left an air space, and on the floor stringers is placed ¾ in., 18 gage Keystone flooring. There is then a layer of cement and hardwood sawdust and a ½ in. layer of compressed cork completes the flooring. Three-ply Sala-

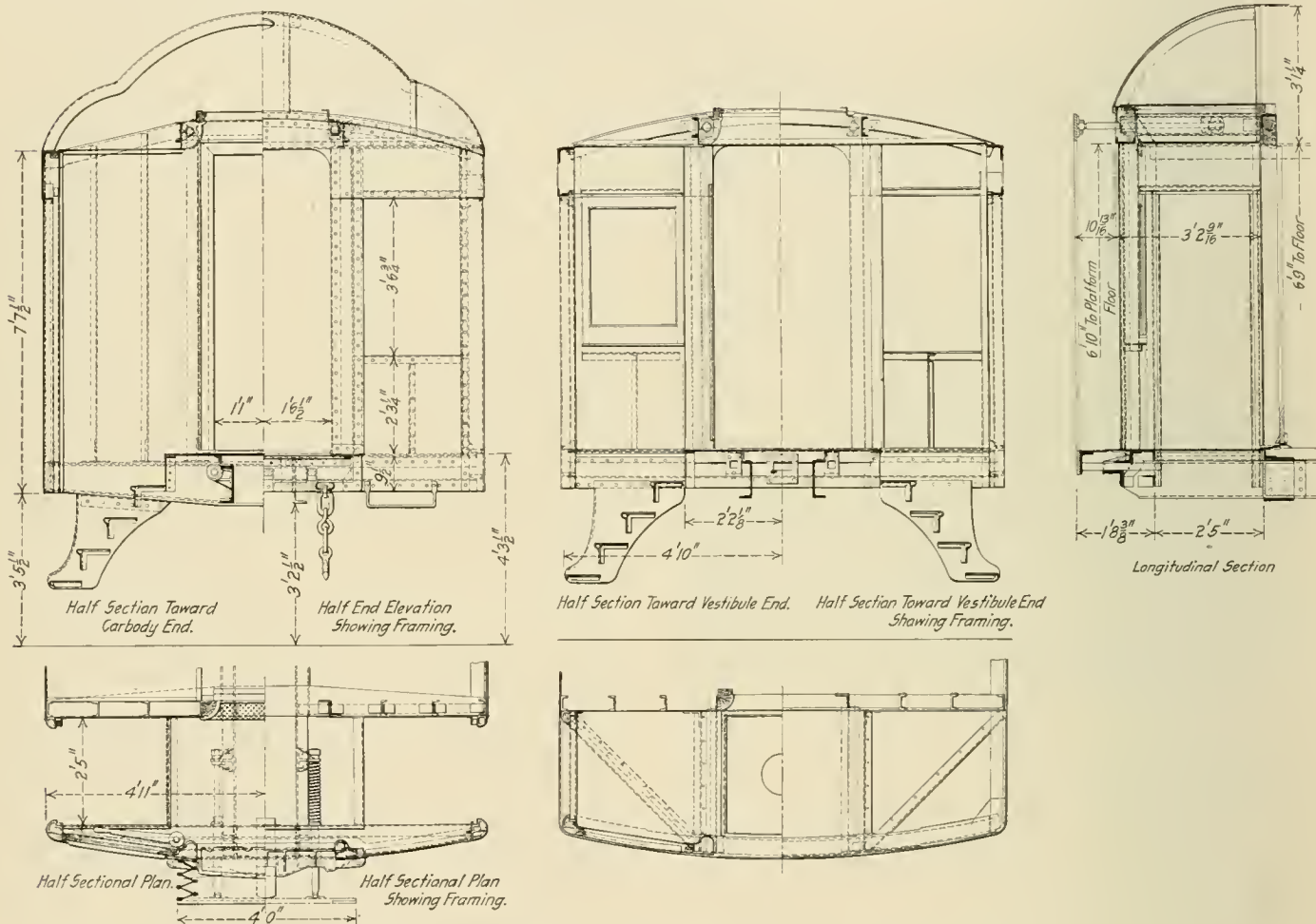

Arrangement of the Vestibule of the Steel Coach on the Canadian Pacific

channel which connects the vestibule posts horizontally at the top there is also an angle forming an arch extending across the car and connected to the channel by plates.

ROOF

The design of the roof used in these cars is unique in steel car construction. While it is in reality of the clerestory type it might correctly be termed a modification of the arch roof. The clerestory or upper deck itself is in the form of an arch, and the deck windows are arch shaped. The carlines at the ends of the deck windows are 3¼ in. by 15¼ in. by 3/16 in. angles and extend between the side plates. Above the deck windows they are tied together at the ridge by 3¼ in. by 15¼ in. by 3/16 in. angles. There is also a lower deck carline used between the two through carlines and the upper end of this is connected to a deck side plate formed of pressed shapes and extending between the through carlines. The roofing plates are 1/16 in. steel with tar paper placed between them and the carlines.

mander is used in insulating the roof, while 2 in. cork is used in the side walls.

OTHER DETAILS

The headlining employed in the upper deck is Agasote, steel being used in the lower deck. The end doors are of steel. Wooden interior finish was used in the first cars, but a system of veneered steel interior finish has been satisfactorily developed and will be employed in future cars. This consists of a steel plate with a layer of canton flannel glued to both sides. Glued to this flannel is a layer of mahogany veneer, and in the case of colonist cars a final layer of birch veneer is used; in the first class day coaches this final layer is mahogany. This veneered steel finish can be bent to almost any shape any number of times without any detrimental effect. There is so little wood used that it is practically fireproof, so that the effect of a wooden interior finish is obtained with steel without the disadvantages of the latter.

The exterior finish is a mahogany color to harmonize with the natural wood mahogany sheathing employed on wooden passenger equipment on the Canadian Pacific.

The cars are fitted with long travel friction buffers and with friction draft gear, a short shank coupler being used instead of the long shank which is common in passenger equipment. The advantage of the short coupler, aside from eliminating unnecessary weight, is that it gives a greater side throw of the coupler head without increased carry iron clearance. The advantages of this were apparently for a long time overlooked by car builders, as the use of long shank couplers continued long after the building of cars sufficiently strong to carry the draft gear out near the

the refrigerant, and the bunker has not been so built as to distribute its refrigerating effect evenly throughout the car. This last was fully established by the use of thermographs and the electric recording thermometers in various parts of the car. The use of a dead air space in cars is not found to be successful. Cork, the best known insulator, which is almost impervious to water, and contains practically no nitrogenous material which might produce decay, has not been used to any great extent in car construction. Wool and hair felt are good insulators, but their high percentage of nitrogenous material makes them good bacterial media when moist. These materials when once moist seldom dry out, and the result is putrefaction, giving rise to

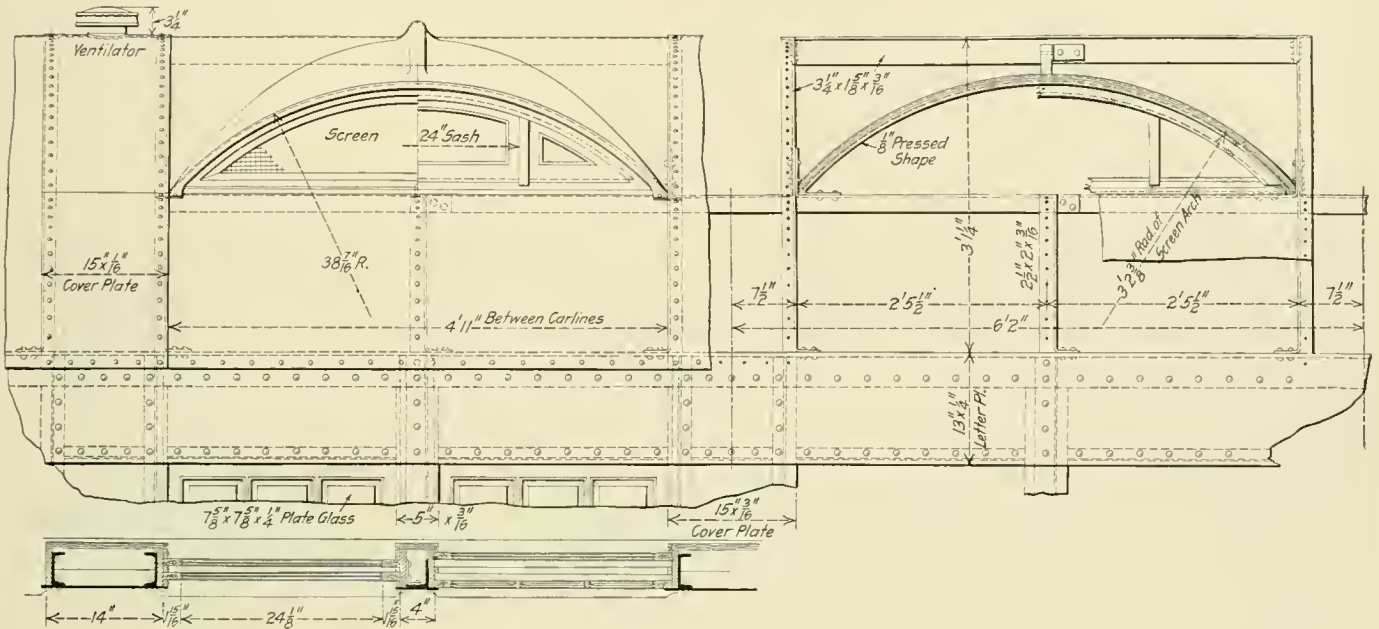

Roof Construction and Section Through Side Windows

end sill. The attachment of the draft sills or side castings at this point also reinforces the steel platform beams and increases the resistance to bending of the platform beams at the end sill.

### TESTS OF REFRIGERATOR CARS

To test the efficiency of refrigerator cars in the shipment of dressed poultry, and to determine the changes that take place in this poultry in transit at different temperatures, the Bureau of Chemistry, United States Department of Agriculture, has made complete examinations and records of 120 carload shipments of dressed poultry, which traveled an aggregate of 140,000 miles. The hauls averaged between 1,000 and 1,500 miles, and terminated generally in New York City. No car was used twice, and many different types of ordinary refrigerator cars were employed. The shipments were made in winter and summer, so that the effect of outside temperatures could be determined. As a result of this experiment it is stated that the builders of refrigerator cars have not kept pace with the refrigerating industry in general.

The experiments indicated that less than 31 deg. F. is the most satisfactory temperature for dressed poultry for long hauls.

The information furnished by these 120 car shipments indicates that most of the refrigerator cars of the United States are not built to maintain the best conditions during warm weather for the transportation of a highly perishable commodity, such as dressed poultry. Certain refrigerator cars are much more efficient than others.

The insulation of the car, in relation to temperature, is its most vulnerable part, with the character of the ice bunker next in importance. In the past the insulation has not been sufficiently heavy to maintain the low temperatures produced by

offensive odors, which contaminate goods. Some of the vegetable or cellulose fiber insulators are perhaps slightly more resistant to moisture and bacterial action, but in time they also become moist, and the alkalis present in such material hasten their chemical decomposition. It is for this reason that car builders are exerting every effort to prevent moisture from reaching the insulation. Mineral wool is least subject to decay, but is difficult to manufacture into strong material.

The insulation in the side walls and floors of the cars used by six different lines shows no radical difference in quality or quantity, though methods of construction in certain cases are preferable. The roof of the car theoretically is most severely taxed to prevent transmission of heat. The most efficient cars studied were those with the best insulated and best built roofs. More attention should be paid to roof and floor insulation, and the latter more effectively protected against moisture.

The wire-basket principle of ice bunker is sound because abundant air access to ice and salt results in increased efficiency. A serious shortcoming of the present types of cars is the impossibility of equalizing the temperature at the center and at the bunker so that all parts of the car are sufficiently cold. Good bunkers and any additional insulation, together with the stowing of the load so as to provide passages for cold air between packages, should materially help to improve results. The well-cooled package does not show changes in temperature corresponding to those in the air of the car, but a long continued increase of temperature or direct contact between the package and the wall of the car, and therefore the source of heat, affects the goods in the course of time. It is the constant or maintained rise in the average temperature of the car that is responsible for objectionable results noted at the expiration of long hauls.



# SHOP FOR STEEL CAR CONSTRUCTION

## Use of Steel for Canadian Pacific Freight and Passenger Equipment Necessitated the Plant

The Canadian Pacific now has in service over 30,000 steel frame box cars of the type described in the *Railway Age Gazette*, May 10, 1912, page 1050, and after some experiments covering two years with a steel car for passenger service, the road has decided to enter extensively into the use of that type of equipment. As it is the intention to carry out the construction of both the steel passenger equipment and the steel frame box cars mainly at the Angus shops in Montreal, a new shop building has been erected for this purpose.

The building is a brick-steel-glass structure with a rectangular body having an extension at one end, as shown on the plan. The width of the main building is 182 ft. and its length 402 ft. 6 in. Beyond this there is an extension having

are within the building and the third is outside at the end of the midway. In the general arrangement of the Angus shops there is a broad midway or drive dividing the shop scheme into two parts. This midway is spanned by a traveling crane which traverses its whole length. Its runway has been extended to overlap the runway of the outside crane of the steel car shop, so that it can deliver material to this shop. All three of the 100 ft. cranes have a travel across the shop, for reasons explained later, while the 70 ft. crane travels parallel to the general movement of the work and material.

The building was started on April 1, 1913, and five months later, September 1, the first car was turned out. By the end of October eight cars per day were turned out, and this output was subsequently increased to twelve per day, working eight hours



The Shop is Exceptionally Well Lighted; Spacing and Punching Machines are Shown in the Foreground

a length of 202 ft. 6 in. and a width of 72 ft. This extension is used for the assembling of freight cars and has a capacity for 10 cars at one time. The erecting portion of the passenger car shop will hold eight cars.

The shop is well lighted. The windows occupy about 26½ per cent of the side wall space, in addition to which there is a series of ventilated skylights 14 ft. wide extending for nearly the whole length of the building and spaced 27 ft. from center to center, giving a skylight area of 51.1 per cent of the total area of the roof. The general character of the steel structure is shown by the engravings.

The main crane equipment consists of three traveling cranes of 100 ft. span each and one of 70 ft., the capacity of each being 10 tons. Of the three cranes of 100 ft. span, two

only. The shop was designed for a capacity of ten freight cars per day, in addition to the passenger car work, but it can be operated up to fifteen cars per day without difficulty.

The tool equipment for the freight car work consists of:

- 5 spacing machines for use in spacing the punching of holes in the webs and flanges of center sills, for small Z bars and angles, and for Z bar center sills
- 3 high speed punches
- 1 coping punch
- 1 coping punch for center sills
- 1 assembling template for end frames
- 1 assembling template for side frames
- 1 assembling template for underframes
- 1 storage rack for Z bar center sills
- 1 storage rack for floor stringers
- 1 storage rack for side plates

- 1 storage rack for center sills
- 1 storage rack for side sills

For the construction of passenger cars the equipment consists of:

- 1 assembling template for underframes
- 1 coping punch
- 2 high speed punches
- 1 coping punch for center sills

- 1 set of plate rolls
- 1 spacing table for plates
- 1 plate planer
- 1 plate shears
- 1 spacing table for belt rail
- 1 transfer table

In addition to the above there are a number of rivet heating furnaces in the assembling portion of the shop, so located as

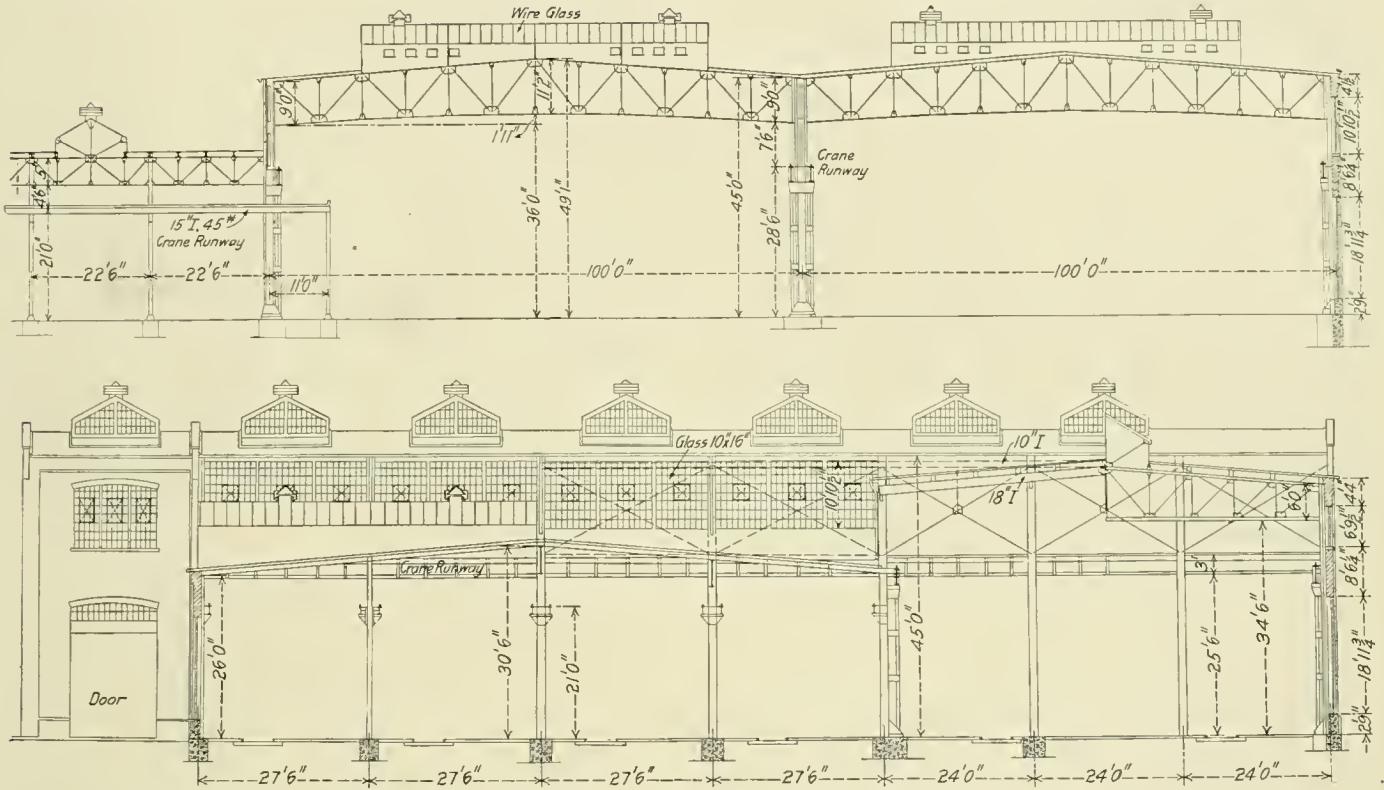

Sections Through the Canadian Pacific Steel Car Shop

- 1 angle shears
- 1 metal cold saw
- 1 metal hand saw
- 2 spacing tables for roof plates
- 1 set of bending rolls for roof plates

to be convenient to the work. Oil is the fuel used in every case. The tools are all located in the main body of the shop as indicated on the plan.

The fundamental idea followed in the passage of the material

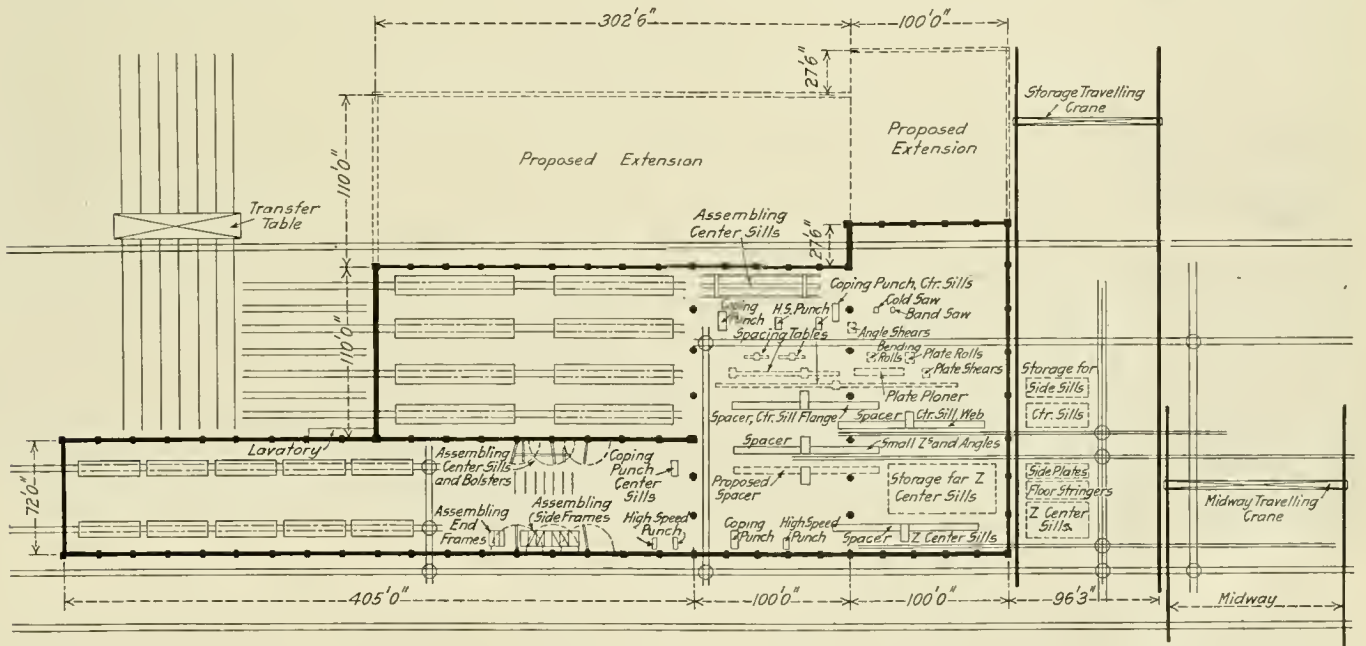

Plan of the Canadian Pacific Steel Car Shop



through the shop is that of having it travel on one course from its entrance as shapes, cut to length, to its exit as finished material in the form of a car. At first sight it seems strange that the travel of the two 100 ft. cranes should be at right angles

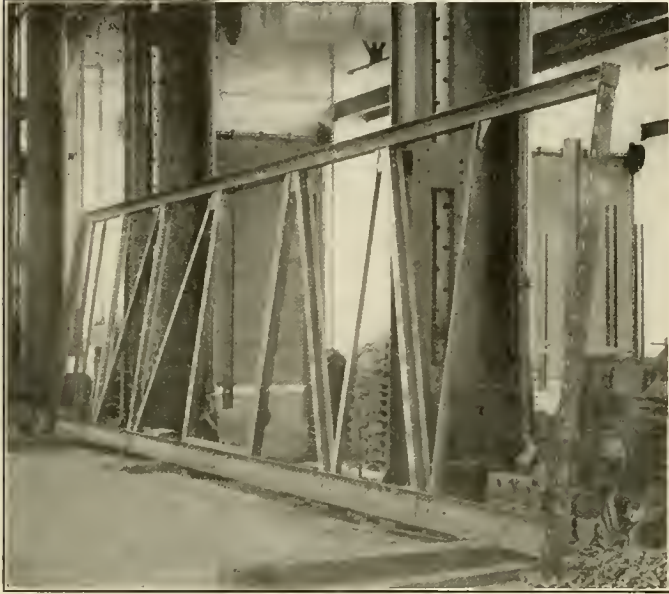

A Side Frame Ready to Go to the Erecting Frame

to the course of the material instead of parallel to it. The reason for this is that it is often necessary to carry material across the shop from one tool to another, while the movement in the general direction of rough material to finished car is effected by the passage through the punching machines themselves. Thus, for example, the shapes enter at the north end, are carried to the punches in the first bay and are moved on

out required. This consists of a strip of wood with steel pins projecting from it at proper intervals. The stop of the spacing machine strikes one after the other of these pins and, as it drags after it the shape which is being punched, it stops the latter at the exact spot under the punch where the holes are to be made.

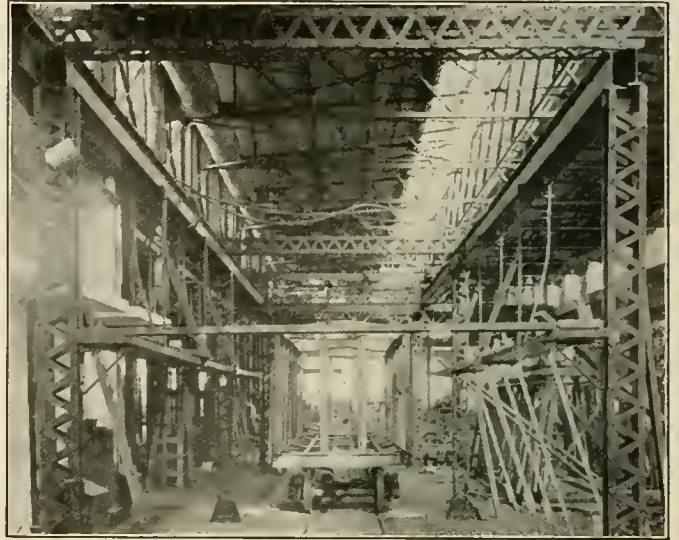

Erecting Frame Used for Freight Cars

The work done is very exact and all parts are thoroughly and perfectly interchangeable.

For punching the short pieces, a simple method of spacing is used. The punch is kept running continuously and leading out from one side is a bar in which holes are drilled to correspond to the spacing desired in the piece to be punched. One man drops a drift into the hole nearest the punch, and the helper, on the other side, pushes the shape against the drift. The punch



Template for Setting Up Side Framing; the Pockets are for Holding Tools

through them to the second. Here the transverse crane carries them to the next machine and the punching is completed.

With the spacing machine a single template bolted to the side of the rack by which the machine is moved is all of the laying

comes down and makes the first hole. As it rises the drift is shifted to the next hole and the piece brought against it, when it is in place for the second hole, which is punched by the downward motion. Again the drift is shifted with a repetition



of the other motions until the work is done. These holes are punched in the lighter parts at the rate of about 36 a minute.

The underframes are assembled on one side of the erecting shop and the side frames on the opposite side, with the stock of parts required for each piled on the floor between, thus making the material accessible for both gangs and admitting of the bringing in of additional material without interrupting or

location of the several parts and the frame is then moved forward to another similar assembling table, where the side sills and other parts of the end framing are added and the whole riveted up. In the case of the cover plate for the bolsters, and some other of the bent parts, the holes are punched in them and the pressed steel webs; but, as both of these parts are apt to be irregular, due to the process of forming them, they are clamped together with screw clamps and drifts, and then all holes are reamed to fairness with an air driven reamer.

With the side and underframing assembled separately in this way, the latter is run forward on its trucks under the erecting



General View of the Freight Car Erecting Floor



Freight Car Erecting Shop Showing the Erecting Frames in the Background

interfering with the work. For the side frames there is a series of racks on the floor in each of which the several vertical and diagonal braces are kept separately. Nearby there is a horizontal jig or template on which the whole side frame is assembled. On this template the sills, plates, braces and posts are laid in place and brought into adjustment by drifts and cotter drifts, very little bolting being used. The cotter drift is merely a drift with a hole for a flat wedge cotter at one end.

frame, over which there is a traveling crane, running parallel to the tracks, as at this point the manufacturing has been completed, and the work consists of handling the material forward

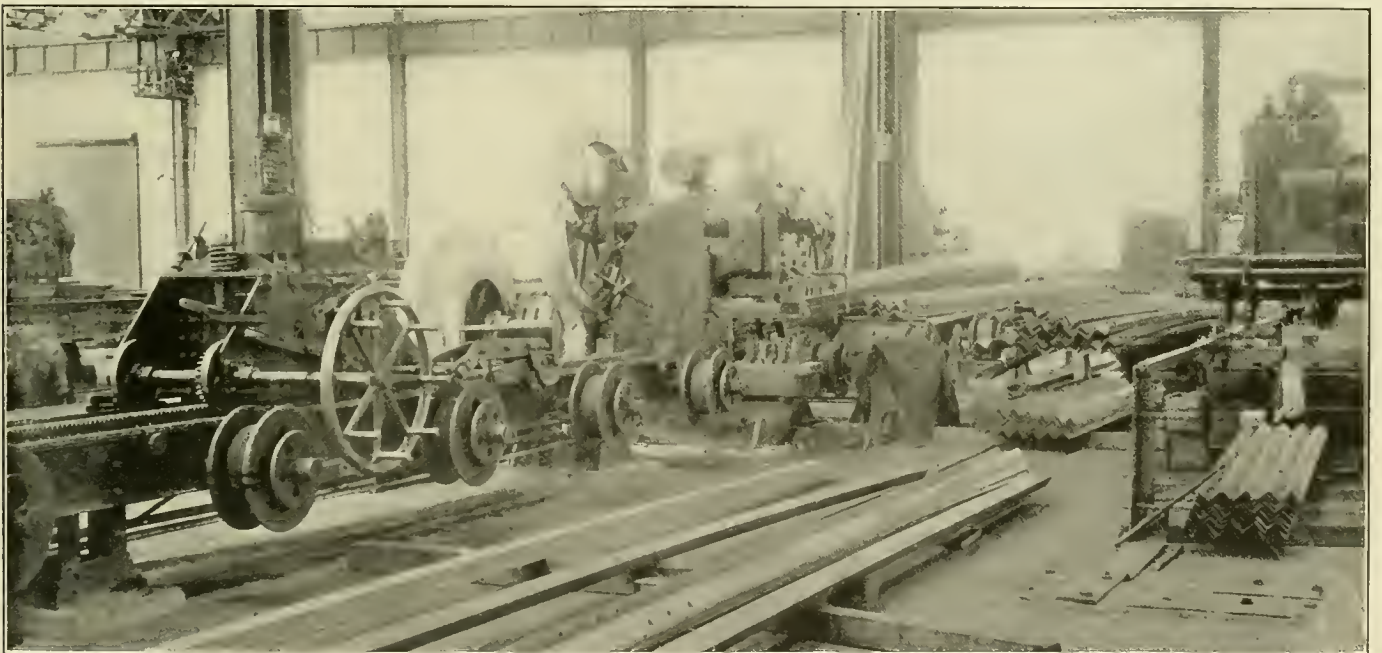

The Machine at the Left Draws the Piece Through the Punch and Automatically Stops It at Points Where Holes are to be Punched

to hold it firmly in place. When the whole frame has been put together it is riveted on the template before being taken to the erecting frame.

The underframing is assembled in substantially the same manner. The center sills and cross bearers are assembled on stationary iron pedestals that are arranged to properly gage the

for erection. The whole process is exceedingly simple, and the shop is exceptionally free from litter at all times.

Under the erecting frame, the side and end framing are lifted to place on the underframing by the overhead crane, being first bolted and then riveted. As the underframing is placed on the trucks before this is done, the completed skeleton of the box



car is ready to be hauled to the woodworking shop for the application of the sheathing, floor and roof as soon as the riveting of the frame is completed. It is run out, painted by spraying and then sent to the woodworking shop for completion. However, the type of metal roof now being applied on a small order is placed on the car in this shop and the steel sheathing of pas-



Runway for the Outside Traveling Crane

senger equipment cars is, of course, applied there, the cars afterward being transferred to another shop for finishing.

The erecting frames for both the passenger and freight cars are similar. Those for freight car erecting consist of a frame supported by six lattice columns and fitted with a runway for a small overhead traveling crane, by which light material is han-

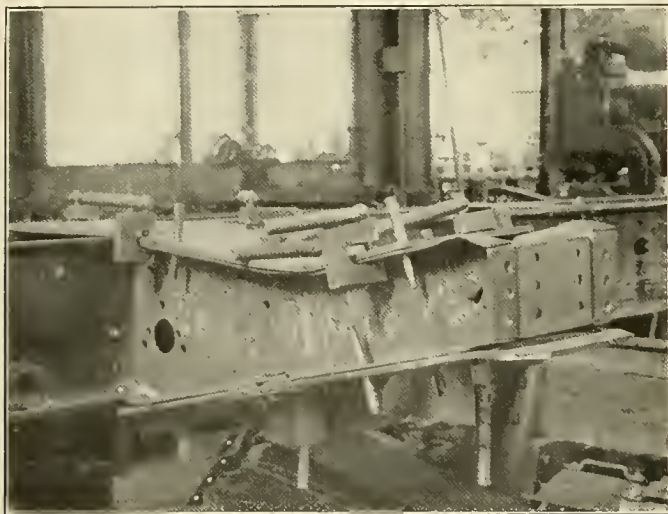

Setting Up an Underframe, Showing Clamps and Drifts in Place

dled. They have a length sufficient to accommodate two cars and are provided with a scaffolding on each side for the accommodation of the workmen.

**VENTILATING THE UNDERGROUND.**—Under the old method of ventilating the tunnels of the Underground railways in London, the air was withdrawn by means of an exhaust fan. By the device now being installed at the Edgware Road, Euston, and at the new Embankment station, unlimited supplies of air will be pumped into the tunnels throughout the day and night. Ordinary air is passed through a washing screen which extracts all impurities, the requisite humidity is next imparted, a proportion of ozone added, and it is then sent into the stations at the rate of 25,000 cu. ft. per minute.—*The Engineer.*

## REINFORCING OLD WOODEN FREIGHT CARS

BY W. M. BOSWORTH

Mechanical Engineer, Louisville & Nashville, South Louisville, Ky.

The reinforcing of old wooden cars of 60,000 and 80,000 lb. capacity with steel underframes and heavier draft gears is giving some railways a great deal of concern, while others have not given it the attention which it demands. It is useless to apply new roofs to such box cars, which are used in heavy trains with steel cars and get the same rough usage in hump yards, and expect the new roof to be at all times water tight and protect the lading, unless a steel underframe is applied. It is also useless if the car is turned out after repairs with the old wooden draft timbers and the light spring draft gear so prevalent in old wooden equipment.

Box cars should preferably have an entire steel underframe, which will eliminate the truss rods and the variable amount of camber, as it is this camber which causes strained and leaky roofs when cars are roughly handled, with a consequent damage to the lading. The side doors and fixtures will also give the best results on cars which have the steel underframe, with truss rods omitted.

The re-application of wooden draft timbers and the light gear is much the same as throwing so much money away, as the cars are in service only a short time before another set of timbers is required and the draft gear needs attention. If an all-steel underframe is prohibitive on account of cost, the car should be equipped with steel draft arms, connected by steel center sub-sills with the neutral axis as near the center line of draft as possible to take the shock and minimize the strains on the roof. With a steel underframe or center sills, a good friction draft gear, reinforced ends if needed, substantial side door fixtures and a good flexible outside metal roof, there are thousands of wooden box cars which could be made serviceable for the next ten years or more, with the cost of maintenance reduced to a minimum. Older box cars which would not justify the expense of steel underframes or steel center sills, could be equipped to advantage with metal draft arms with wood sub-sills between which would keep these cars from going to the repair tracks on account of wooden draft timber and bolt troubles.

For gondola and flat cars an entire steel underframe is not deemed necessary. Such cars could no doubt have the steel center sills omitted, and by applying a substantial design of steel draft arms with heavy wood center sub-sills from arm to arm, the draft timber trouble would be eliminated for the remaining life of the car.

The better wooden cars should also have an approved design of metal body and truck bolsters applied along with the other reinforcements.

**DISCIPLINE ON THE LONDON & NORTHWESTERN.**—A bulletin showing the list of fines administered to various mechanical employees on the London & Northwestern, dated August 25, 1892, and signed by F. W. Webb, superintendent, shows how careful this railway was in maintaining its discipline. Engine-men, firemen and cleaners were fined nominal sums for various causes from passing signals set at danger to smoking in the shop. The maximum fine was about \$5 for passing a signal at danger and causing a mishap. The smallest fines were two shillings and six pence, or about 60 cents; these latter fines were levied for causing smoke nuisance, smoking a pipe in a shed, causing damage to lubricator, being late out of the roundhouse causing delays to trains, overrunning passenger station platforms and for derailments due to carelessness. Other employees were dismissed for disregarding signals, for damaging the paint on an engine with a penknife, etc. At the present time a fireman will be laid off two or three days on account of wiping his engine over with paraffine oil, as it decreases the luster of the varnish.

# SHOP PRACTICE

## NOTES ON PRESENT DAY RUNNING REPAIRS\*

BY W. E. DUNHAM

Supervisor Motive Power and Machinery, Chicago & North Western,  
Winona, Minn.

With the almost universal change in the type and arrangement of running gear and valve motion of the American locomotive that has taken place during the past few years, there has also developed a maintenance situation that calls for a considerable reorganization and rearrangement of many divisional shop forces.

On some roads where it was considered that a locomotive should receive a general overhauling once a year and one intermediate heavy repairing as well, we find that the time between the general repair shopping has been extended to two years, and that the intermediate repairs are made in the roundhouse as running repairs. Where 75,000 miles was the limit for giving a passenger locomotive a general overhauling, many of them are now making 150,000 miles between shoppings and a similar proportion is resulting in the case of freight power. In fact in some "good" water districts the boiler is now the controlling factor in shopping rather than the machinery, as was formerly the case. To meet this situation there naturally has arisen a tendency toward spreading out of shop facilities rather than concentrating them at one or a few points.

There is a large shop economy in the outside valve gears with their pin and bushing connections that are readily accessible, easily renewed and open at all times to close inspection. No shop or roundhouse man who has handled both the inside and outside gear, would ever be in favor of discarding the present outside gear for the old inside. With this striking example before us, it is desired to call attention to locomotive design in general and in some detail where it is believed considerable economies can be obtained if the matter of the care of running repairs is given close attention.

The care required to keep up the pin connections of driver brake rigging, particularly in the numerous levers and hangers, is no small bug-bear to the average roundhouse foreman. If the rigging is originally constructed with standard bushings and pins throughout, it is easy to understand the ease and promptness of making repairs by going to the storekeeper, getting a new standard bushing and a new pin and pressing the old bushing out and the new one in place in one operation. In many instances the parts would not have to be taken down, as repairs could be made in place, with proper tools. It is no doubt true that the first cost of a fully bushed brake rigging would be much in excess of the present generally used design; however, when taking into consideration the large amount of repair work constantly needed on brake rigging, and the amount of blacksmith shop work required to restore, and in many cases renew the various parts of the rigging at the time of shopping, it would appear to be a self-evident fact that the additional original cost would soon resolve itself into a large economy during the whole life of the locomotive.

What has been said regarding pins and bushings in the brake rigging applies with equal force to spring rigging. We also find very few, if any, spring riggings and brake riggings put up with or arranged for any lubricating facilities at the bearings. A roundhouse man who systematically oils these parts as best he can, knows from the practical results obtained that he is saving considerable labor and material. A single trial of oiling the spring rigging will invariably convince the most skeptical that there is a large shop economy in the plan, and also an easier

riding engine. If all the larger bearings, at least, were originally equipped with simple oiling facilities, a considerable economy in wear could be expected.

On a great many roads it has been found to be a very desirable practice to change driving tires for re-turning instead of dropping the wheels and turning the tires on the original centers. Where such a practice is in vogue, particular attention should be given to the necessary clearance around and in front of the wheel centers, to permit the tires to be heated and removed with the minimum amount of stripping of other parts of the locomotive.

On any line where there are a large number of curves, and frequently the combined feature of grades and curves, the matter of lateral wear of the engine and trailer truck wheels and drivers is of great importance. As large a hub face and box face as possible is a very desirable detail. As an example of following old proportions, I have in mind an engine truck detail where a box with a 14 in. over-all width dimension is used. The axle has a 6 in. wheel fit, and the wheel has an over-all hub face diameter of 11 in. The natural result of wear is that the 11 in. hub bores a hole in the face of the box and the box usually comes to the shop as scrap. The life of this hub and the box could very easily be extended considerably if the wheel hub face was made 14 in. in diameter, and thus get the full benefit of the entire face of the box as it now exists, increasing the bearing surface fully 100 per cent. In addition to this there are the four corners of the box which would receive no wear and which could be brought into play by a hub or wearing plate, even larger than 14 in. in diameter.

In the case of the trailer trucks, the designer is not limited by any recommended or standard practices and can readily give full consideration to the subject of lateral wear. With the prevailing tendency, however, to reduce the weight of steel castings, the hub face has usually come as a second consideration. Naturally, the strength of the hub to safely withstand the axle pressure fit, is the primary consideration, and as a result, the hub face has been usually taken as a sequence to that consideration instead of being one of the primary details. A hub face on a trailer that is small will, the same as with engine truck wheels, result in excessive lateral wear in a very short time. In some instances under local conditions this lateral will require attention as often as once in six weeks or two months, whereas six months would not be unreasonable to expect the locomotive to run without developing excessive lateral.

In addition to the consideration of bearing area in lateral detail, there is the subject of readily maintaining this lateral within the desired limits, without sending the engine to the back shop. Removable or adjustable hub liners and box face liners for engine and trailer truck wheels and for drivers have been schemed out with apparently indifferent success. In too many instances the poor results obtained were due to the light construction of the parts, which soon broke in service and were lost out, making the resulting condition worse than the one which it was endeavoring to correct. A substantial liner, easily and firmly secured in place and capable of being prepared in advance to the proper thickness to take up lateral wear, can no doubt be adapted to all older as well as new power.

With all the driving axles on the modern outside valve geared engines free of obstructions between the frame, there is a strong reason for considering having the driving box brasses held in position by keys or locks, rather than a pressed fit, so that new brasses can be applied to the boxes in the roundhouse, without dropping the wheels or sending the engine to the shops. For other than main drivers, some roads are reported as having fitted

\*Abstract of paper read before the Western Railway Club, April 21, 1914.



up the brasses for rolling action only, using a slip brass with a crown fit of somewhat the same type as the usual engine truck box brass. With generous main brass bearing and sufficient shoe and wedge surface, this plan would appear to be a perfectly reasonable one and worthy of careful consideration. Knowing as we do that with the main boxes and brasses closely lined up the other driving boxes and brasses can and should run with the wedges down somewhat and the journal brass fitted a little loose, would it not be reasonable to start out with a design to suit that condition?

Solid end main rods are meeting with favor where tried. The elimination of the strap bolts is no small gain to the roundhouse man and "file main rod brasses" does not mean so much of a job for him as it did when he had to knock out a lot of strap bolts, possibly destroying one or more in the operation and at all times be very uncertain as to when he could expect the job to be done. Instead of letting it go another trip because he was particularly rushed that day and did not want to get tied up on a hard job he now cleans it up when first reported.

"Examine packing; both sides blow," means a lot of work just to find that lubrication was not good or that there was some other minor defect and that broken or worn out packing rings was not the trouble. A lengthening of the piston rod so that the piston head would come outside the front end of the cylinder without disconnecting the crosshead fit, would help materially in such work and also avoid disturbing a connection that should be left alone as much as possible.

Another feature of the piston rod and head detail is the use of a built-up type of head in which a bull ring is arranged that can be renewed to suit the wear or re-boring of the cylinder without the necessity of applying a new piston head and disturbing the piston and head fit. The roundhouse can thus readily keep the piston head true to the cylinder with minimum expenditure of time and labor.

Where the eccentric and straps of the Stephenson link motion are still in use, a liner of brass or special wearing metal for the strap means a lot of time saved in curing a "lame" engine. These liners, when kept in stock all turned and bored for a quick application, assist the roundhouse man materially in overcoming lost motion and keeping the locomotive square.

The bearing surfaces of crossheads are ordinarily made of such a shape and secured in such a way that the taking up of the wear usually means dismantling the crosshead or disturbing the guides. The latter is a prolific cause of piston packing troubles, in that the guides are not always again set up true to the cylinders. With the numerous examples of substantial crossheads used in stationary practice that have ready and practical means of adjustment for wear, it would seem as though our locomotive practice should develop a scheme for taking up the crosshead wear that would be practical and satisfactory. There is no doubt but that the general adoption of some such scheme would save much roundhouse labor and overcome very many of the annoying steam leaks in the piston packing.

For any part of the country where the water is of the quality known as "good," that is, where there is no accumulation of scale on the flues or deposit of mud or sludge in the boiler, there is no doubt but that the welding of all of the flues in the flue sheet would be entirely successful. Most of us, however, are not blessed with such ideal conditions. The water we are using is generally heavily charged with incrusting solids and has large amounts of mud in it, which form deposits on the flues and usually at the most inaccessible points of the boiler. At the same time we are laying out our flue sheets with the flues staggered the same as we did years ago, with the fond idea that it is the most efficient plan for permitting the generated steam to rise through the water with the least amount of resistance. Should we not lay out these flues with the principal thought in mind as to how the boiler washer could get at each flue and get the scale down and out without forming a bank? With the in-

formation given us in a fully authoritative manner that the flue heating surface is of secondary importance to the fire-box heating surface, should we not more thoughtfully consider the matter of facility in washing out when laying out flues?

The author cannot but believe that if considerable care and attention are given in advance to the details connected with the several parts of the locomotive that usually wear out of shape and proportion, there will be large returns in the lessening of delays incident to the making of repairs.

#### DISCUSSION

While this paper was not discussed as thoroughly as the subject might demand, it was clearly pointed out that while the roundhouse workmen might find it difficult to make repairs on account of the design of engines, it was often necessary in specific cases to disregard the repairman's viewpoint in order to obtain the design necessary to give the most economical operation. The universal welding of the flues in the tube sheet was questioned in that, especially in bad water districts, it would be an absolute waste of money to do this, as the tubes would become pitted to such an extent that the tube itself would fail before it began to fail in the tube sheet, thus making the welding a superfluous operation. On one road, it was stated, difficulty has been found in maintaining the large superheater flues in the flue sheet; it was afterwards found that they were originally put in holes much too large for the tube, the joint being made by the use of shims. It was suggested that the large flues be swaged down to a slightly smaller diameter, and then rolled into the flue sheet. This practice, it was stated, has given specially good results.

As regards removing wheels or tires on account of flat spots, instances were mentioned where these flat spots, ranging from 3 to 6 in. in length, were repaired by the oxy-acetylene process, chips from the wheel lathe being used as the flux. On the Chicago, Milwaukee & St. Paul this practice has been performed at an average cost of about \$8 per engine, for 15 engines.

## PUNCHING HOLES IN BRAKE STAFFS

BY R. F. CALVERT

The tool shown in the accompanying engraving has been in successful use at the Horton, Kan., shops of the Rock Island lines for about three years, for forming and punching holes in brake staffs. With the use of this die it is possible to turn out from 200 to 250 brake shafts an hour.

The device is used with a punch and shear. Block *A* is made to fit the machine, and on this there are placed two punches  $5\frac{3}{4}$  in. apart, one of these being  $9\frac{1}{16}$  in., and the other  $5\frac{1}{16}$  in. On

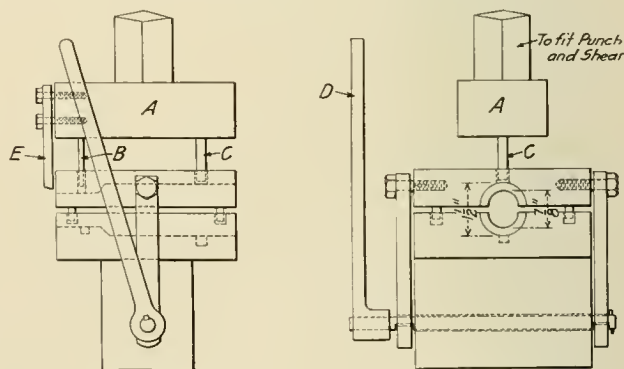

Die for Forming and Punching the Ends of Brake Staffs

the end of this block is fastened a shear blade as shown at *E*, for cutting the staffs the proper length. The two halves of the die proper are, when a staff is being inserted, held apart about  $\frac{1}{2}$  in. by means of the lever *D* and the connecting links and eccentric shaft. A staff is heated to a red heat in a furnace and then the end is placed in this die. The lever *D* is then pulled down, closing the die and at the same time forming the end.











of looking up schedule numbers for all of the various items involved.

After the form shown in Fig. 8 has been signed by the foreman, it is sent to the office of the timekeeper, where the schedule number and price are checked and the percentage

CANADIAN PACIFIC RAILWAY COMPANY						
ANGUS LOCOMOTIVE SHOPS						
PIECE WDRK DEPARTMENT						
MONTHLY PIECE WORK REPORT						
STEAMFITTERS - Shop		Month ending Feby. 21, 1914.				
NAME	OPERATION	No. of CONTRACTS CLOSED	TOTAL CONTRACT	TOTAL WAGES	% GAIN	% LOSS
	Brake Cyls.	61	\$ 45.32	\$ 51.64	43	
	Strip Pipes.	28	40.30	56.45	10	
	Remove Pipes.	29	13.65	19.21		28
	Elec. Wiring.	33	93.22	78.30	19	
	Elec. Headlight	31	113.90	99.93	13	
	Cut 5" Tubee	23	54.37	41.10	32	
	Screw Nipples	12	53.40	35.70	45	
	Clean Valves.	21	32.08	26.48	12	
	contraols.	9	35.20	33.59	04	
	Repair Pumpe.	4	12.60	10.34	23	
	Repair Pumpe	14	65.75	57.37	14	
	Repair Pumpe.	14	60.00	55.12	08	
	Iron Reprs.	6	102.14	123.35		20
	Iron Reprs.	2	38.24	36.31	05	
	Iron Reprs.	5	101.13	128.47		13
	Iron Reprs.	2	12.65	12.23	03	

Fig. 11

of the day work amount is calculated. Each man's balance is then distributed to the various accounts and all shortages for the month are deducted; the record is then transferred to the payroll.

(2-10-13-X125)

**CANADIAN PACIFIC RAILWAY CO.**  
ANGUS LOCOMOTIVE SHOPS  
PIECE WORK OFFICE

March 4, 1914.

Mr. Chief P. W. Inspector

The \_\_\_\_\_ Shop

presents below his "DAILY PIECE WORK REPORT"  
for March 3, 1914.

No. of men on roll	214
No. of men working	194
No. of men absent	20
No. of men productive	148
No. of men non-productive	46
No. of men on supervision	5
No. of men clerical	1
No. of hours productive	1182 1/2
No. of hours non productive	414 1/2
No. of hours supervision	47 1/2
No. of hours clerical	9 1/2
No. of hours piece work	830 1/4
No. of hours day work productive	352 1/4
Tools and Machinery	39 1/2

Remarks \_\_\_\_\_

Signed \_\_\_\_\_ Foreman

Fig. 12

PIECE WORK REPORTS

In each of the methods outlined, after the foreman has signed the form, the amount earned by each man is recorded on a card, which also shows the per cent gained or lost over day

wages. For each shop there is also prepared a monthly piece work report like that shown in Fig. 11, from which the names of the men have been omitted. From this the shop officers

CANADIAN PACIFIC RAILWAY COMPANY												
ANGUS LOCOMOTIVE SHOPS												
PIECE WORK OFFICE												
WEEKLY PIECE WORK REPORT, WEEK ENDING JANUARY 30, 1914.												
SHOP	TOTAL EMPLOYEES		TOTAL HOURS		Per Cent of Regular Hours Accounted for		TOTAL PIECE WORK HOURS (7)	Per Last PIECE WORK PROO. HOURS				BEST RECORD
	Pro (1)	Non-Pro (2)	Pro (3)	Non-Pro (4)	Pro (5)	Non-Pro (6)		Present Week (8)	Last Week (9)	Last Week (10)	Per (11)	
BOILER	524	41	25852	1655	123	101	20456	79	79	79	90	12/27/13
BLACKSMITH	134	20	5618	982	105	123	4413	78	79	76	84	8/2/13.
BRASS	67	9	2609	395	98	110	2082	79	84	78	84	1/23/14
BOIL (4 days.)	19	3	800	127	105	106	527	66	65	76	90	3/7/13.
CAPTR. & TNDL.	47	14	1538	505	102	113	1111	72	69	70	82	12/6/13.
ERECTING	217	55	7720	2390	89	109	5440	70	75	82	87	5/24/13.
TENDER WHEEL	10	3	354	135	88	112	331	93	90	76	97	11/22/13
FRIG	99	37	4243	1578	107	107	3519	83	82	80	93	5/6/13.
MACHINE EAST	139	62	5740	2620	103	106	4270	74	77	75	81	5/13/13.
MACHINE WEST	105	20	4273	913	102	114	2858	69	71	69	78	11/22/13
PAINT	22	3	884	115	100	96	884	100	100	100	100	1/30/14.
PATTERN	21	12	836	559	99	116						
STEAMFITTER	59	17	2461	798	105	117	1970	79	77	80	89	6/14/13.
SPRING & BRACE	52	47	1987	1982	98	105	617	31	26	60	60	2/1/13.
TINSMITH	35	5	1308	197	91	98	1145	87	90	89	97	9/6/13.
ELEC. DEPT												

Fig. 13

can determine at any time whether the productive efficiency is increasing, remaining stationary, or falling behind.

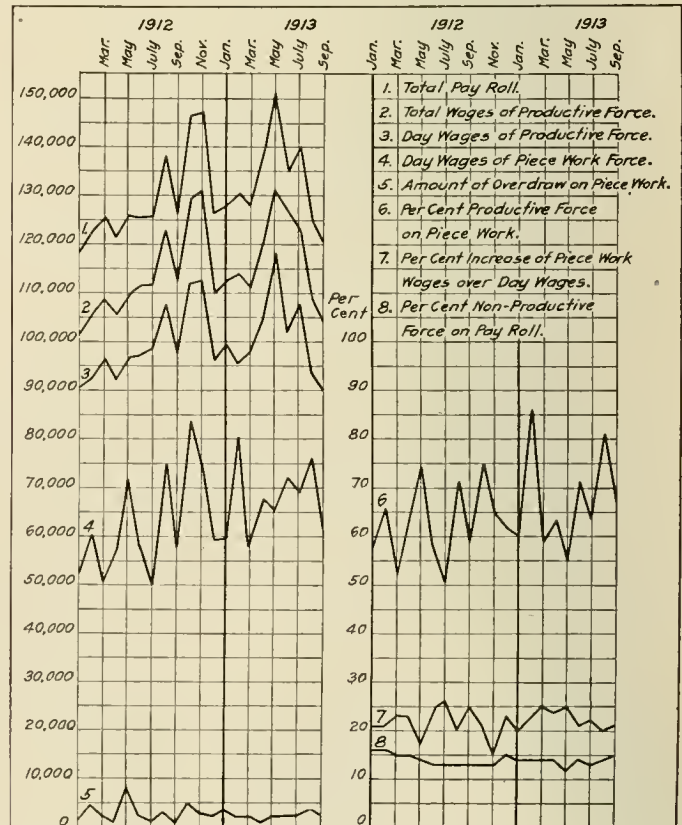

Fig. 14—Summary of Pay Rolls for All Shops from January, 1912, to September, 1913

Fig. 12 shows the daily report made out by the foreman of each shop. A weekly piece work report on an hour basis is also used and is shown in Fig. 13. It should be explained in connection with this form that all employees such as foremen, clerks, sweepers, etc., whose time cannot be directly distributed to the different accounts, are classified as non-productive. The report shown in Fig. 13 gives a great deal of valuable information to the shop officers, and is largely self-explanatory. In obtaining the figures shown in column 5, those in column 1 are multiplied by the number of working hours in the week and column 3 is divided by this result. Column 6 is obtained similarly from columns 2 and 4. Column 8 is obtained by dividing column 7 by column 3.

Fig. 14 shows in plotted form a summary of all shops from January, 1912, to September, 1913.

The idea in mind in arranging the system as described was to set piece work prices which were fair both to the men and the company. When prices are set by a busy shop foreman or a rate setter who has far too large an amount of work to handle to make an individual study of it, there are naturally a large number of rates which are not suited to the work, resulting in wrong distribution of labor and costs and much dissatisfaction on the part of a man when the class of work varies as it does in a locomotive repair shop. A viewpoint held is that prices that are fair for the man are those which will enable him to make a substantial increase in his wages in return for his best efforts, and that they are fair to the company when they are set so that a man must make use of all the advantages which are placed at his disposal, and is guided by the methods which are found to be the most economical.

The system of going into the work and making a study of it with the men has removed the distrust that is often present between the men and the officers of a company, and has at the Angus shops proved decidedly satisfactory to all.

In using the gages, an apprentice or a helper passes the graduated end of gage No. 1 through the staybolt sleeve until it rests on the ball, as in Fig. 2. The boilermaker, who is inside the boiler, notes the length necessary, and then marks the hole with a center punch or some convenient means of identification, and proceeds in the same way for as many holes as require bolts. After obtaining the different lengths required, gage No. 2 is used. The head of the bolt is placed in the ball at C,



Fig. 2

bringing the stem in alinement with the graduations on the gage, and noting from the list whatever length is required, the bolt is marked where it is to be cut and stamped with the number of the hole. The bolts are then cut and threaded ready for the boiler.

## FUEL OIL BURNER

BY H. E. BLACKBURN

Apprentice Instructor, Erie Railroad, Dunmore, Pa.

A portable fuel oil burner made of pipe fittings mounted on an auxiliary air reservoir is shown in the accompanying engraving. This burner weighs only 25 lb., and can be made at a very small cost. One of them has been in daily use in the car shops at Dunmore for over two years without causing any trouble. The burner is absolutely safe, for if the hose blows off

## GAGES FOR FLEXIBLE STAYBOLTS

BY L. BROWN

Demonstrator, Angus Shops, Canadian Pacific, Montreal, Que.

The illustrations show two gages for determining the lengths for cutting flexible staybolts. The use of these gages permits the bolts to be threaded and made ready for the boiler without any doubt as to their being correct in length, and also obviates the necessity of having to remove a bolt after it is screwed into place, because the length is not correct.

The jig in Fig. 1 has at A a circular part which is made to

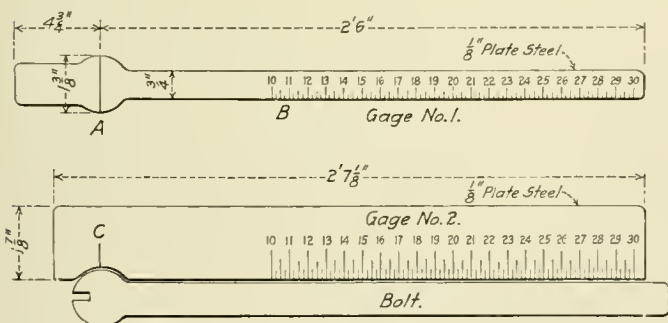
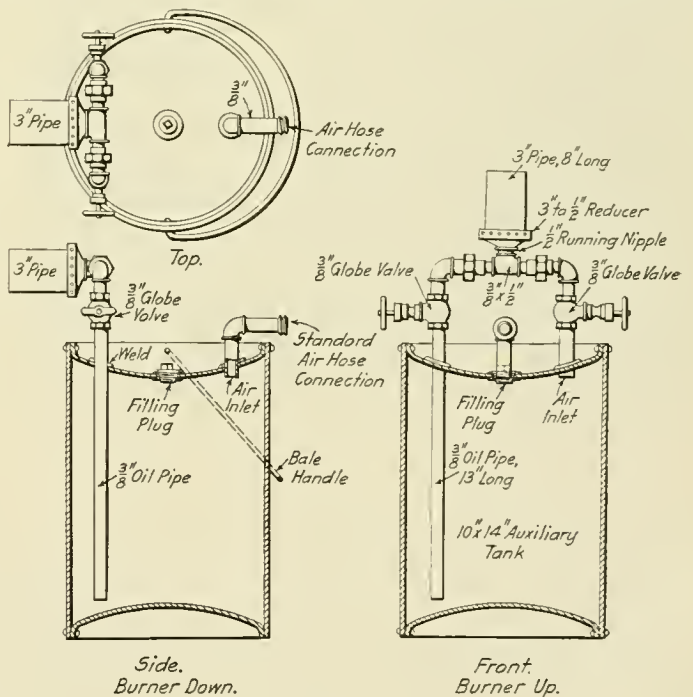

Fig. 1

suit the ball joint of the staybolt sleeve in which the staybolt head seats itself; above this is an extended end which is used as a handle. A line is cut across the center at A and from this point the gage is graduated, beginning at B and running to 30 in. in 1/8 in. graduations. The gage in Fig. 2 is made with a semi-circular piece cut out at C to receive the circular head of the staybolt which is to be marked for cutting.



Burner Which Uses Fuel Oil

the flame will go out. It has been used in small and difficult places without any accidents, such as are sometimes experienced with a kerosene or a gasolene torch. The construction of the atomizer in the reducer is such that the air blast beats the oil into a spray. This spray is evenly discharged into the reducer where it ignites and spreads to the walls of the hood, causing a



whirling motion that generates the oil into a gas as it mixes with the air from the intake holes. The flame is of a high temperature, is readily controlled and will not easily go out.

### A HOME-MADE POWDERED COAL PLANT

BY J. G. COUTANT

Considering the amount of thought that has been given to the use of powdered coal, there is but little authoritative and practical data available on the subject. Most writers seem to have the same opinions on certain points, among which may be mentioned the following:

The fuel must be very fine for economy; it is recommended that 95 per cent should pass through a 100 mesh screen.

The fuel must be dried, expelling all the moisture possible, and reducing the moisture content to less than 1 per cent.

Adequate means must be provided for removing the ash from the flues and combustion chamber.

The coal employed should contain very little sulphur.

The question frequently arises as to how serious these points are and how much they may be deviated from and the furnace still be practical. Variations occur, depending on the design of the furnace and whether it is used for high or low temperature work.

The writer has made several trials with a very crude pulverizer and furnace, under very unfavorable conditions, and some very interesting results were obtained.

Having found it necessary to consider a cheaper fuel, powdered coal suggested itself, but the question arose whether fuel of the

Dominion bituminous coal 14,303 B. t. u.—

Moisture .....	3.00	per cent
Volatile combustible .....	34.00	per cent
Fixed carbon .....	54.10	per cent
Ash .....	6.00	per cent
Sulphur .....	2.90	per cent
	100.00	per cent

To make the necessary experiments a very inexpensive outfit was used, as shown in Fig. 1. The pulverizer was a multiple grinder made by the Hardy Patent Pick Company, Sheffield, England, and consisted essentially of four interior communicating chambers of successively increased diameter in which paddles revolved on arms with correspondingly increased radii. The largest chamber contained a screen through which only the fine dust passed. Coal of the analysis given, previously crushed to nut size, was fed into the hopper by hand, this being the only means of regulating the necessary supply of coal to the furnace. The combustion air blast was connected to the pulverizer just below the hopper to transfer the coal to the pulverizer chamber. The coal was thrown out radially by centrifugal force due to the rapidly-revolving arms and reduced to dust by percussion and attrition and delivered by air current through the screen to the furnace.

This apparatus pulverized coal containing 3 per cent of mois-

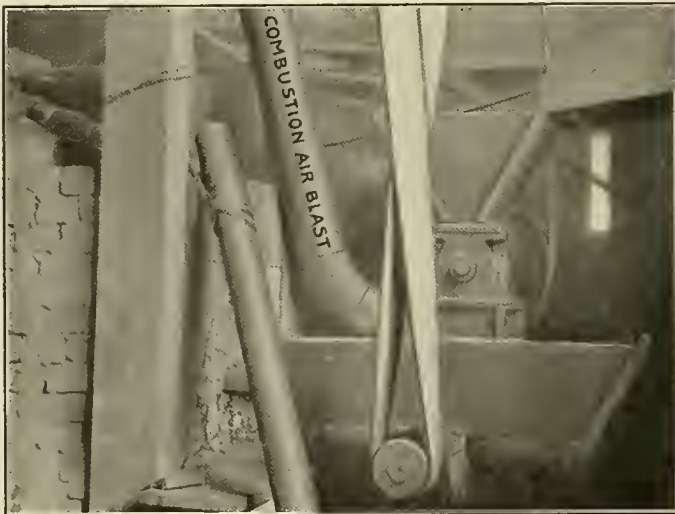

Fig. 1—Arrangement of Apparatus for Pulverizing Coal

following analysis, which could be purchased in the local market, would be suitable for the work:

American bituminous coal 12,932 B. t. u.—

Moisture .....	2.00	per cent
Volatile combustible .....	31.00	per cent
Fixed carbon .....	54.15	per cent
Ash .....	11.75	per cent
Sulphur .....	1.10	per cent
	100.00	per cent

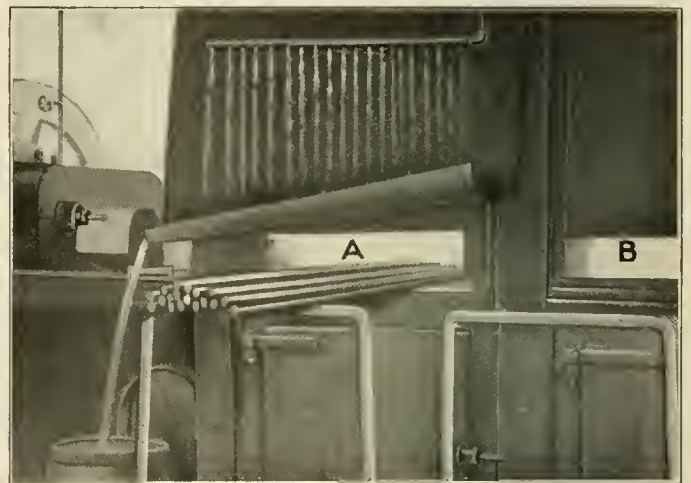

Fig. 2—The Powdered Coal Fire Is Shown at A; B is a Hard Coal Fire

ture to a fineness of 78 per cent through a 100 mesh screen, or 91 per cent through a 60 mesh screen. The coal was burned in the furnace with very satisfactory results.

The furnace used was an ordinary 5 ft. 9 in. by 2 ft. 9 in. anthracite coal furnace used for heating long rods from which rivets and spikes were made. To make the furnace adaptable for burning powdered coal it was necessary to build a 3 ft. combustion chamber on the rear as shown in Fig. 1, and to remove the grate bars and fill the furnace with brick, to make a hearth on which to lay the rods as shown in Fig. 2. This illustration also shows that there is very little difference between the appearance of the powdered coal furnace *A*, when working well, and an anthracite coal fire, *B*.

The table shown below gives the results obtained with this inferior outfit, and also for comparison, the daily average record of another furnace which was equipped with an automatic coal feeder and was operating under the most satisfactory conditions, is given in the last line.

Weight and size of spikes	Total coal burned, lb.	Total furnace hours	Weight coal per hour	Weight of spikes per hour	Coal per 2,000 lb. spikes	Remarks
2,600 lb.—½ in. x 12 in.	840	9 35/60	89.5	272	645	No work during morning
2,600 lb.—½ in. x 12 in.	585	4 35/60	127.5	566	450	Afternoon run only
5,000 lb.—½ in. x 12 in.	1,430	10 30/60	136	476	572	
4,600 lb.—½ in. x 12 in.	1,224	10	122	460	532	
½ in. x 12 in.	.....	..	...	...	580	Daily average of furnace with satisfactory coal feeder

# GENERAL MACHINE TOOL EFFICIENCY

Discusses Such Influencing Factors as Movement of Material, Grouping, and Machine Replacement

BY GEORGE W. ARMSTRONG

Mechanical Department, Erie Railroad, Meadville, Pa.

There is always a tendency for production cost to increase with an increase in wages. In order to prevent this, as well as to decrease it on account of the stress of competition, a thorough investigation into the economical operation of a plant is necessary. This is commonly designated as its efficiency. Efficiency is a term at present enjoying wide-spread popularity as a panacea for all disorders. In reality, it is only common sense combined with ability to profit by and utilize the results of others' investigations.

The efficient operation of a plant is very largely influenced by its layout as well as its equipment. These are both controlled by the nature of the industry. For purposes of analysis and preliminary considerations of layout, all plants may be divided into three general types:

(1) Those producing one line only; for example, a tube factory.

(2) Those manufacturing articles requiring similar operations to a certain point, and then slightly different, to suit individual requirements, as a furniture factory.

(3) Those doing a diversified or repair business, illustrated by a railroad shop.

It is chiefly with the latter that the writer will deal. This

*Preliminary Considerations.*—A careful and complete study of the situation with respect to output immediately required and future anticipations, and the provision of floor space for material in process of manufacture and its procedure through the shop should precede all other work. The data thus obtained furnishes the basis upon which later the "process diagram" and its accompanying "routing diagram" are worked out. The "process diagram" is a tabulation in detail in proper order of the operations which the material is to undergo, graphically presented in the "routing diagram." These diagrams are the foundation on which the later efficiency of the plant to a large extent depends, as they show the inter-relationships which should exist between operations and processes to accomplish the result with maximum economy.

*Movement of Material.*—Frequently this study will point to the advisability of establishing more than one storage point for material in order to reduce labor charges for handling, or the introduction of some means of mechanical handling, as crane conveyors, overhead trolley conveyors, industrial trackage, etc. Careful consideration should also be given to the floor space required for materials in transit from one operation to another, and the method of storage. Suitable buggies or convey-

TABLE 1—COMPARISON OF LINE SHAFT DRIVE AND INDIVIDUAL MOTOR DRIVE FOR MACHINE TOOLS

Item	Line Shaft Drive	Individual Motor Drive	Advantage of Individual Motor Drive
1. Power consumption	Constant friction loss in shafts, belts and motors, power for cutting.	Friction loss (motor and tool only); useful power only while working.	Less power required.
2. Speed control	No. speeds. No. cone pulleys. No. gear ratios.	No. speeds. No. controller points. No. gear ratios.	More speed possible; time saved in speed adjustments.
3. Reversing	Clutch and crossed belts.	Reversible controller.	Time saved in reversing.
4. Adjusting tool and work	Stopping at any definite point very difficult.	Can be started in either direction and stopped promptly at any point.	Time saved in setting up and lining up.
5. Speed adjustment	Large speed increments between pulley steps.	Small speed increments between controller points.	Time saved by obtaining proper cutting speed.
6. Size of cut	Limited by slipping belts. Large belts hard to shift.	Limited by strength of tool and size of motor.	Time saved by taking heavier cuts.
7. Time to complete job			Much less time required as indicated by previous items.
8. Liability to accidents	Slipping or breaking belts, injury of machine tool, cutting tool or prime mover.	Injury to machine tool, cutting tool or motor.	Much less liability to accidents.
9. Checking economy of operations	Close supervision required; very difficult to locate cause of delay.	Accurate tests possible by means of graphic meter which automatically records delays and rate of cutting.	Delays and remedies easily located without personal supervision.
10. Flexibility of location	Location determined by shafting and changes difficult.	Location determined by sequence of operations; changes readily made.	Greater convenience in handling and increased economy of operation; more compact arrangement possible.

type of plant presents most of the problems and utilizes the principles applying to the first two classes. Owing, however, to the diversified nature of the product, the solution is more difficult and requires frequent compromise to conform to conditions and the principles of ideal working. Efficient operation depends primarily on conformity with:

(1) Movement of material as directly as possible from store-room to the finished product and without retracing its path; and, when advisable, installation of facilities to minimize handling.

(2) Grouping of machines handling co-related work, making each group complete for the production of its specialty.

(3) Machines so equipped as to afford sufficient latitude in speed and feed to fit conditions of operation; such changes to be capable of being effected with a minimum effort on the part of the operator.

(4) Machines so constructed that the limiting factor for output shall be the tool rather than the machine.

ing buckets for electric cranes can often be introduced for storage of small parts in process of machining, which will materially affect the cost of production of these articles. Long hauls should be avoided whenever possible, as in many cases the labor charges for handling exceed the direct machining costs and every means should be taken to reduce them to a minimum.

*Grouping.*—Grouping of machines handling co-related work will aid materially in minimizing handling. Machines should be located in sequence of operations as far as permissible, so as to facilitate progress of material. Occasionally, however, a machine may be necessary in two or more groups, and the work in any one of the groups be insufficient to utilize the full capacity of the machine. In considering whether duplication of machines is advisable, in instances of this character, the handling cost must be carefully weighed against the interest and depreciation charges incurred through installing additional machinery for convenience only. The groups must be arranged with re-



gard not only to uniform routing within themselves, but with due consideration to the inter-relationships, especially where necessary machines are not duplicated. Machines should be preferably located in lanes and so placed as to afford easy communication with the main passageways.

Having developed the "process" and "routing" diagrams, the layout is best accomplished by using cardboard templates of the various machines required. The outline of each template should indicate the overall dimensions of the apparatus, and if greater than the foundation units, the latter should be indicated by dotted lines within the limits of the template. The problem of tool layout now becomes one of "checkers," i. e., so moving and locating machines that they shall embody the principles involved.

MOTOR DRIVE

Intimately connected with the layout is the question of drive. Motor drive more readily commends itself, as shown in Table 1, taken from the A. S. M. E. Transactions for April 12, 1910.

Motor drive facilitates efficient routing, as it permits of flexibility in location of the tool to meet changing conditions. Latitude in speed and feed to fit conditions of operation, provided at the convenience of the operator, will result in more nearly utilizing the machine's capabilities. The elimination wholly, or to a large extent, of line shafting with the accompanying belts,

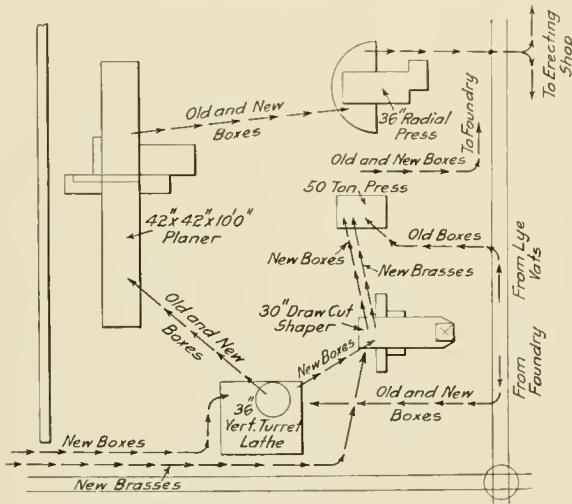

Fig. 1—Arrangement of Tools in the Driving Box Section

besides reducing maintenance costs, will improve the light distribution.

The question of direct or alternating current motors is one largely influenced by local conditions. Where the requirements, however, demand variations in speed, direct current motors are preferable owing to the greater facility in securing such variations. The power required for the machine is best left to the tool builder, unless considerable experience has been had in this line.

REPLACEMENT OF MACHINES

In considering a shop in existence it quite frequently is advisable to replace old machines as well as to re-locate. This requires considerable analysis, further than the determination in reduction of labor costs for machining, as the overhead charge is commonly as great as or greater than the direct charge. By using the method indicated below, combined with the analysis of benefits to which no monetary value can be assigned, a fair indication is secured of the justified policy.

FIXED OR OVERHEAD CHARGE ON NEW MACHINE

- (1) Interest on net investment, or A plus B.  
A = cost of machine.  
B = cost of installation of machine.
- (2) Depreciation on machine.
- (3) Power costs.
- (4) Maintenance of unit complete with its driving accessories.
- (5) Machine's percentage of the overhead on building in which it is situated, overhead on power house equipment and of supervision and clerical force.

The yearly overhead charge is the sum of the above items on a yearly basis.

EARNING VALUE OF THE MACHINE

$$\text{Earning value} = O \times (M - N)$$

$$\text{Per cent return on investment} = \frac{[O \times (M - N)] - F}{\text{Net cost installed}} \times 100$$

- O = yearly output
- M = cost per unit to produce on old machine
- N = cost per unit to produce on new machine
- F = yearly overhead charge

The depreciated life is influenced by ordinary wear and tear on the machine, service conditions, obsolescence due to developments in tool steel and inadequacy from increase in size of parts requiring machining. A fair average for the depreciated life is 10 years, which will adequately take care of the above conditions.

EXAMPLES

As illustrating the method pursued in attacking the problem of efficient layout, the grouping procedure is given in detail for the driving box section (Fig. 1) of a shop turning out 20 locomotives with heavy repairs.

PROCESS DIAGRAM

- |  |  |
|--|--|
| <p><b>New Boxes</b></p> <ol style="list-style-type: none"> <li>1. Face sides. Boring mill.</li> <li>2. Shape crown bearing and cellar fit. Draw cut shaper.</li> <li>3. Shape brass to fit box. Draw cut shaper.</li> <li>4. Press brass in box.</li> <li>5. Pour liner.</li> <li>6. Bore to fit axle. Face liner. Boring mill.</li> <li>7. Plane shoe and wedge fit. Planer.</li> <li>8. Drill oil holes, cellar pin holes, etc. Radial drill.</li> <li>9. Fit cellar.</li> </ol> | <p><b>Old Boxes</b></p> <ol style="list-style-type: none"> <li>1. From lye vat to press. Press brass out.</li> <li>2. Shape brass to fit box. Draw cut shaper.</li> <li>3. Press brass in box.</li> <li>4. Pour liner.</li> <li>5. Bore to fit axle. Face hub liner. Boring mill.</li> <li>6. True shoe and wedge fit. Planer.</li> <li>7. Drill oil holes.</li> <li>8. Fit cellar.</li> </ol> |
|--|--|

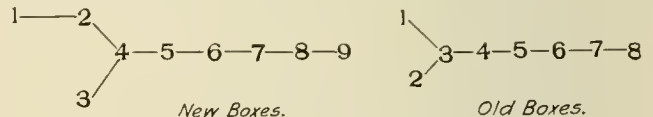

ROUTING DIAGRAM

TIME STUDY BASED ON 20 HEAVY REPAIRS PER MONTH

Machine	Operation	Number pieces and total time
42 in. x 42 in. x 10 ft. Reversing motor drive Planer	Plane shoe and wedge fit, new boxes	16 per month
	20 x 8 x 10%	3½ days' work
	Ave. time per box, 1¾ hrs.	
	Plane shoe and wedge fit, old boxes	144 per month
Draw cut shaper Morton 30 in.	20 x 8 x 90%	22½ days' work
	Ave. time per box, 1¼ hrs.	26 days' work
	Total 3½ + 22½	
	Shape crown bearing and cellar fit, new boxes	16 per month
36 in. Vertical Turret lathe (Bullard)	20 x 8 x 10%	2½ days' work
	Ave. time per box, 1¼ hrs.	
	Shape crown brasses, new and old boxes	120 per month
	20 x 8 x 75%	11¼ days' work
3 ft. Radial Drill	Ave. time per box, ¾ hr.	
	Fit cellars to boxes	32 per month
	20 x 8 x 20%	2 days' work
	Ave. time per box, ½ hr.	15¾ days' work
36 in. Vertical Turret lathe (Bullard)	Total 2½ + 11¼ + 2	
	Face new steel boxes	16 per month
	20 x 8 x 10%	2 days' work
	Ave. time per box, 1 hr.	
36 in. Vertical Turret lathe (Bullard)	Bore brass to fit axle, old and new boxes	120 per month
	20 x 8 x 75%	10 days' work
	Ave. time per box, ¾ hr.	
	Face hub liner, old and new boxes	160 per month
36 in. Vertical Turret lathe (Bullard)	20 x 8 x 100%	10 days' work
	Ave. time per box, ½ hr.	22 days' work
	Total time, 10 + 2 + 10	
	Drill press	16 per month
36 in. Vertical Turret lathe (Bullard)	Drill new boxes	5 days' work
	20 x 8 x 10%	
	Ave. time per box, 2½ hrs.	
	Drill old boxes	120 per month
36 in. Vertical Turret lathe (Bullard)	20 x 8 x 75%	7½ days' work
	Ave. time per box, ½ hr.	12½ days' work
	Total time, 5 + 7½	

The time study is very necessary in connection with the process and routing diagrams in ascertaining whether it is necessary to so place machines that they serve more than one group in order to obtain maximum production. At best, the actual time the machine is in operation is but 50 per cent of the total working time. As the overhead charge per working hour is

piece-work, probably no material decrease in cost of shop operation could be predicted. Piece-work being a 100 per cent premium system, no decrease in cost is effected as output increases. Nevertheless, given efficient working conditions, the output per forge or machine being increased, the shop output is thus favorably increased, and the force could be reduced, allow-

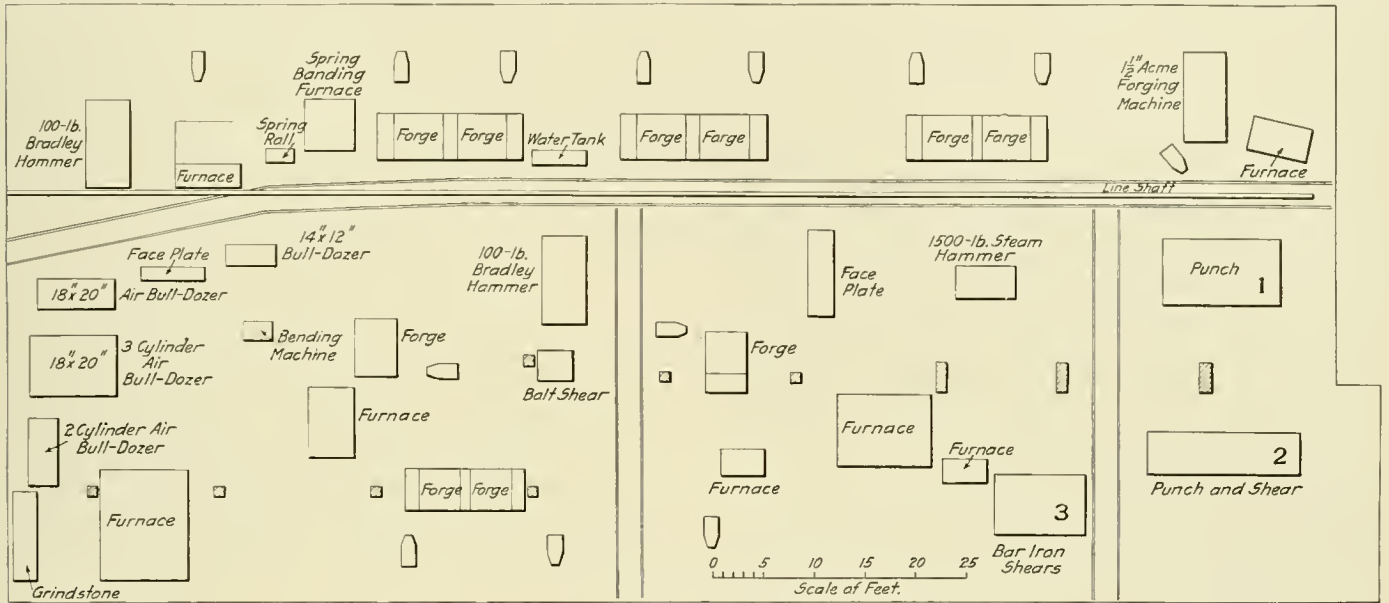

Fig. 2—Layout of Smith Shop Before Tools Were Re-located

100 per cent to 200 per cent of the labor charge, it is of the utmost importance to utilize a machine tool to the greatest possible extent.

In the case considered above, the problem to be met was in connection with a new layout. It frequently is advantageous to rearrange an old layout to obtain more efficient working conditions. Such is the case in the study of the blacksmith shop

ing higher earnings to employees retained, thereby tending to less dissatisfaction with working conditions.

Introducing more efficient working conditions and securing greater output with the same original investment and supervision reduces the overhead charge upon that output. Thus, labor charges remaining fixed, the total cost of output is reduced. Securing increased output also facilitates other shop ac-

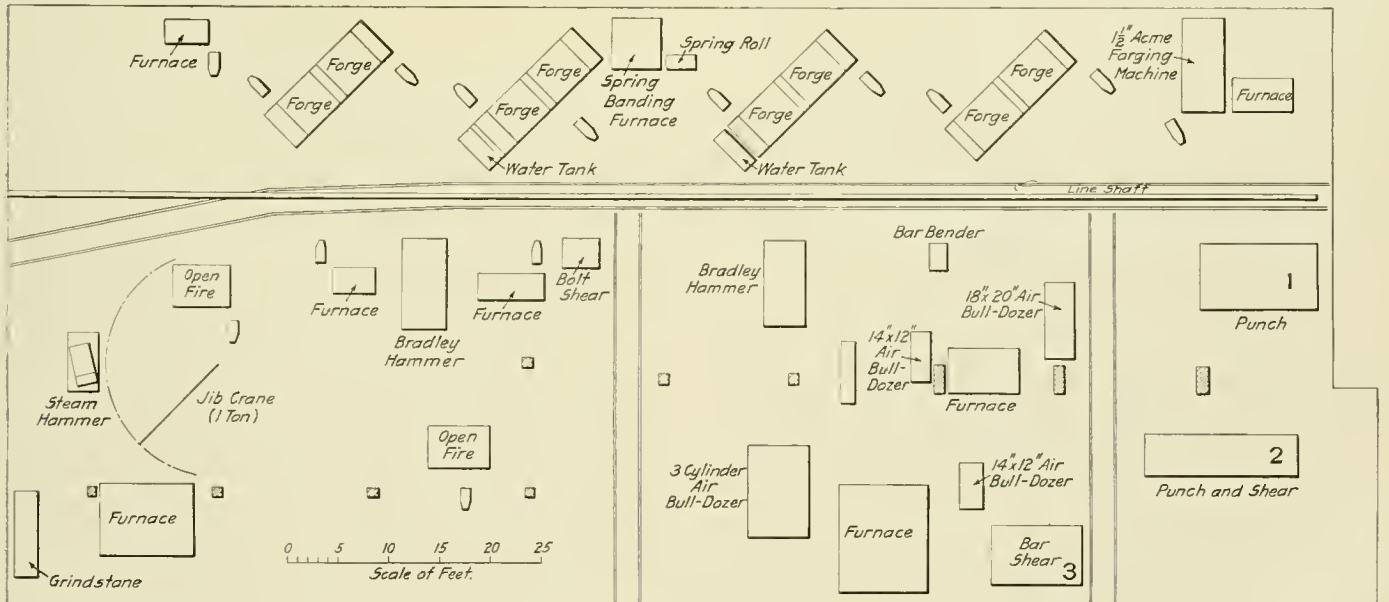

Fig. 3—Plan of Smith Shop After the Tools Had Been Rearranged

(Figs. 2 and 3) presenting conditions existing on many of our railroads today.

Under the old arrangement, the shop is congested and much unnecessary movement and handling of material is required which can be eliminated by a proper arrangement of equipment. Should the shop operate at a high percentage (75 per cent) of

activities by decreasing the delays for material and therefore tends to increase total shop output.

Criticisms in detail of the layout assumed follow, with recommendations from which are evolved the proposed layout.

*Forging Machine and Furnace.*—Congestion at this point is an important factor in reducing the output of the machine. Too



much space is wasted by its present location, and this is reduced to a minimum by relocation and allows much more space for raw and finished material.

**Forges.**—These are not located so as to permit of the greatest available space and further are not all grouped together. By setting at an angle of 45 deg., more space is secured; in fact, more forges could be placed in the allotted space than at present, without undue crowding. All forges also present a clear view to the foreman passing down the aisle and thus render supervision more efficient.

**Bradley Hammers.**—These are not at present located so as to be conveniently accessible from all points of the shop. While one hammer is practically in constant use by one man, still it should be more centrally located. Then by concentrating the operations not requiring much hammer work at adjacent forges, it is free for the use of this one man while still conveniently available for the occasional job.

**Steam Hammer.**—This is at present occupying space which should be utilized by machinery for doing work requiring punching and shearing. This hammer is used almost exclusively by the steam hammer gang, only an open fire having work to perform which could be worked under it. This can therefore be more efficiently placed at the end of the shop nearest the machine shop and the open fire located so as also to be served by the jib crane in case of necessity.

**Bulldozers.**—The present location of the bulldozers is conducive to inefficiency. All material worked on them is first sheared at the other end of the shop and, after being formed to proper shape, is quite frequently returned again for punching. By relocating as shown, a minimum of movement is secured which should materially reduce output cost.

**Punch and Shears.**—Punch 1 should be moved back as shown so as not to be rendered inoperative as at present when long material, as channels or angles, is punched on 2. Shear 3 should be moved nearer the door so as not to interfere with punching wide material on 2, and a small opening with a door should be provided in the wall in line with the shear blade. Punch and shear 2 has not been relocated owing to the difficulty of securing sufficient operating room. It is, however, recommended that if much underframe work is to be done, a covered and enclosed vestibule be provided of sufficient length so that the shop does not have to be open and men stand exposed to the elements. A trolley crane should be provided so as to efficiently handle work at the punch. A vestibule should also be provided so that large sheets can be handled under the shears without the discomforts mentioned above. While these may seem needless details, still they are essential for efficient working.

**Minor Details.**—The open fire at present located next to the steam hammer should be relocated as shown. This fire is an extra one and can be well utilized for brake beam work now performed just outside the building, giving this space for storage room. For handling light material, small buggies are recommended. Their use will reduce labor handling operations and therefore costs, economize space and permit of quick delivery of raw and finished products.

It will be apparent that the congestion has been greatly relieved by the new layout. Considerable difficulty is also experienced because of the posts supporting the roof which is of wooden construction. This difficulty has been eliminated as far as possible by proper grouping.

**WIRELESS ON THE GREAT LAKES.**—According to the Department of Commerce, the disastrous storm of last November on the Great Lakes furnished a signal illustration of the necessity of equipping lake vessels with wireless telegraphy. All vessels so equipped received warning of the storm and sought shelter, while 19 American vessels without wireless were lost. About 50 vessels are now preparing to add wireless telegraph apparatus to their equipment.—*Scientific American.*

## AIR VALVE GAGES

BY J. A. JESSON

Air Brake Foreman, Louisville & Nashville, Corbin, Ky.

The engravings illustrate gages for use in fitting valves in locomotive air pumps. In order to be prepared for any condition arising, a number of valves are kept ready with their bosses faced down in a lathe, beginning at standard, when no wear exists, and ranging in steps of  $1/32$  in. to fill in when wear and reaming of seats have taken place. The values of different heights are stamped 0 for standard and 1, 2, 3, according to variation from standard. After the proper height is obtained it is only necessary to select the proper depth valve by number.

Fig. 1 shows a combined height and depth gage *A*, in use over

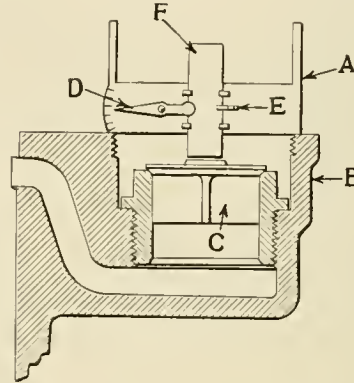

Fig. 1

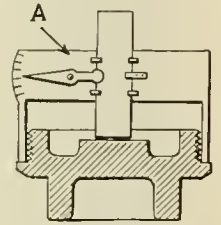

Fig. 2

the upper pump valve *C*, and resting on the body *B*. The slide *F* is held by pins and a flat spring *E*. A semi-circular piece is removed from one side of the slide. The indicator *D* has a circular head that fits neatly in this semi-circular space, and the indicator is held in position by a loose rivet. The graduations are determined by the length of the indicator. The one used by the writer travels  $1/8$  in. for a  $1/32$  in. adjustment of the slide, which renders the reading easy.

Fig. 2 shows the gage in position on the valve cap, and Fig.

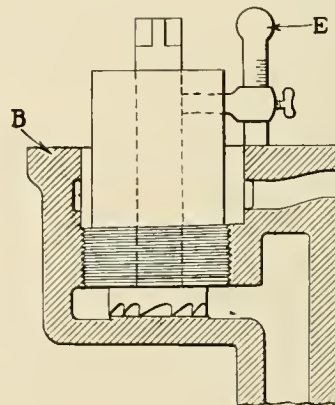

Fig. 3

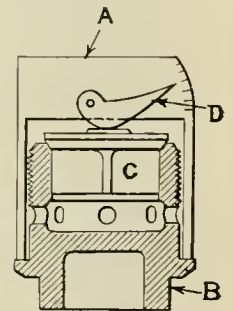

Fig. 4

3 shows a combined reamer and gage, as it is occasionally necessary to square up the valve stop in the body. A gage is extended from the reamer pilot with graduations on its slide, a set screw being provided for holding. As the reamer moves in, the slide backs up correspondingly. Fig. 4 shows a height gage for the valve in a cage; the indicator moves on a loose rivet. This construction permits the use of a large scale in the graduation.

**COAL IN RUSSIA.**—The Russian Geological Committee estimates the coal deposits of Russia and the Caucasus to contain from 70,000,000,000 to 75,000,000,000 tons.

# NEW DEVICES

## ANGLE COMPOUND POWER DRIVEN AIR COMPRESSOR

The accompanying illustrations show a type of air compressor recently placed on the market by the Sullivan Machinery Company, Chicago, Ill. It has been the purpose of this company to design a compressor to operate at fairly high speed, and have

and both sets of valve gear by a single eccentric pin. These machines are built in capacities ranging from 445 cu. ft. of free air per minute, to 1,094 cu. ft., the speed ranging from 250 to 215 r. p. m., respectively. The large size compressor has cylinders 12 in. by 20 in. by 14 in., and occupies a floor space of 11 ft. 4½ in. by 7 ft. 10½ in., and is 9 ft. 9 in. high. In cases where it is desirable to have more than this capacity, double units of these compressors have been used.

One of the most interesting features of the design is the balancing of the reciprocating parts. In this machine the disturbing influences of the horizontal and vertical members tend to offset or neutralize each other. The inertia diagram shown herewith shows how these forces are balanced. Curve *A* represents the forces in the horizontal unit and curve *B* those in the vertical unit. Curve *C* presents the sum of the upper two curves, and approximates a circle, showing that the disturbance produced is nearly uniform throughout the revolution. By applying a revolving weight to balance these centrifugal forces, the resultant unbalanced effect is shown by curve *D*, which reduces the unbalanced forces from approximately 3,000 lb. to 500 or 700 lb. It is claimed that the machine may easily run at the speed mentioned without any noticeable vibration, and on this account it has not been found necessary to have a massive foundation. By absorbing the inertia loads due to the reciprocating parts in the shaft itself, a more uniform distribution of the working pressures has been obtained in the shaft boxes, and on this account they should require less adjustment, the wear being more evenly distributed over the whole surface of the bearings.

The crank shaft is supported in large bearings located on either side of the crank pin and close to it, the load imposed by both cylinders being borne equally by these bearings, without any tendency to rock or spring the shaft or the main frame. The latter is of the heavy duty Tangye type and is strongly

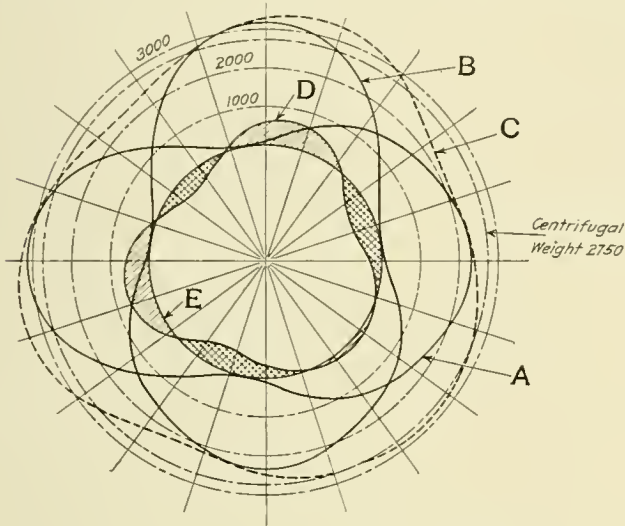

Inertia Diagram of Reciprocating Parts

it simple in construction and occupy as little floor space as possible. As will be noted from the illustrations the low pressure cylinder is placed horizontally and the high pressure cylinder

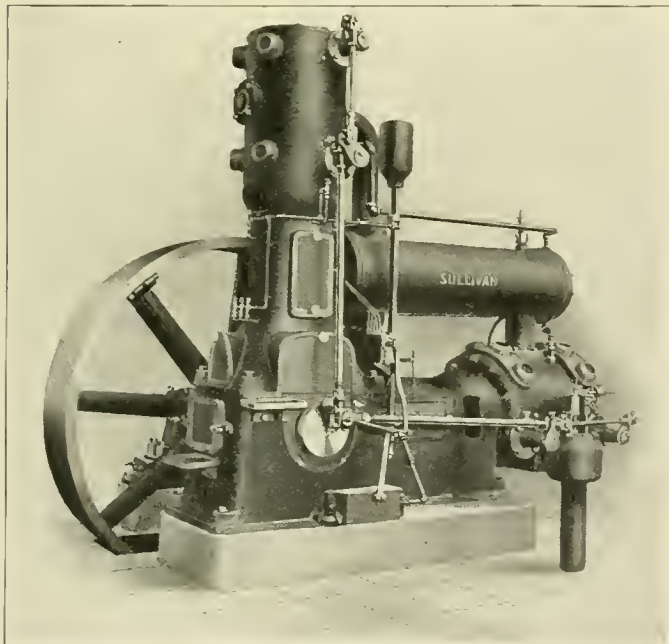

Sullivan Angle Compound Air Compressor

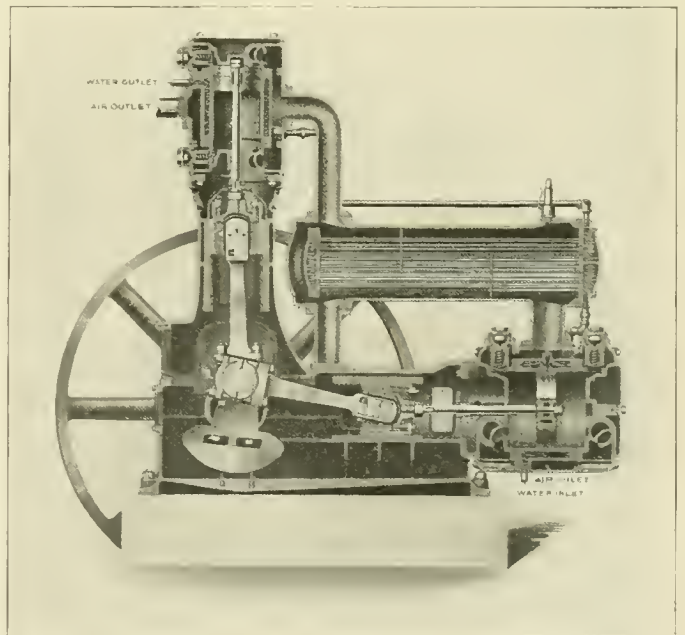

Sectional Elevation of the Compressor

der vertically on the frame. This arrangement permits of small floor space, as well as making it possible to more accurately balance the reciprocating parts of the compressor. Both the high and low pressure pistons are actuated by a single crank,

ribbed. The guides for the low pressure crosshead and the jaws for the crank shaft boxes form part of the frame casting. The bottom of the frame is solid, forming a reservoir for the oil, but there are openings in the sides for inspecting the



crosshead. The main bearings are made of cast iron and have four parts. They are lined with babbitt and have a set screw adjustment. They are so designed that all four parts may be removed without removing the main shaft.

Both the low and high pressure cylinders are made with separate liners forced into the frame castings, the spaces between the liners and cylinder castings forming the water jackets. The air inlet valves are of the Corliss type, being made of cast iron, and are cylindrical in shape. They may be removed by removing the back bonnets and withdrawing the valves by means of screw handles, without disturbing the cylinder heads or the valve gear. The air discharge valves are of the poppet type, internally guided on cast iron plugs, and are held to the seats by light steel springs. They seat in bronze cages and are easily removed by unscrewing the valve plugs. The intercooler is a cylindrical cast iron shell, consisting of a nest of aluminum tubes, which may be easily removed. The crank shaft bearings, crank and crosshead pins and crosshead guides of both the high and low pressure members, are supplied with stream oil lubrication.

These machines may be driven by either a belt or a direct connected motor. When a motor is used it is necessary to use a flywheel.

### STREET TYPE C LOCOMOTIVE STOKER

The accompanying illustration shows the latest form of Street locomotive stoker, designated as Type C, as applied to a locomotive. This stoker retains the general features of the Type B machine, which consists of a screen in the floor of the tank, through which the coal passes to a screw conveyor, which carries it from the tender to the locomotive. On the locomotive, it is deposited in a hopper from which it is, by means of an endless chain elevator, carried to a discharge pipe above the fire door. The discharge pipe embodies a screen which re-

moves the dust and small particles, and deposits them through a center distributor, across the back end of the grate under the fire door. The larger particles pass over the screen and are divided between two side distributors which distribute them over the remaining section of the grate.

The Type C machine differs from the Type B in having a variable speed engine for driving the elevator, and a friction clutch for making connection between the engine and the elevator. The variable speed engine was introduced for the purpose of giving the fireman an absolute control over the quantity of coal to be conveyed to the firebox. This engine has seven different speeds and is controlled by a small lever on the front of the crank case. By setting this lever in a given notch, a fixed feed of coal is obtained, and is maintained regardless of the load on the engine. This enables the fireman to duplicate results in his firing on different locomotives and at different times on the same locomotive.

The friction clutch enables the fireman to start and stop the feed of coal instantly at any time. The elevator engine is allowed to run continuously, and by throwing in the clutch lever, the elevator can be started and the feed of coal to the firebox begins at once, as under normal conditions the elevator buckets are full of coal. Throwing the clutch lever out stops the feed of coal.

These two improvements in the Street stoker have been in the course of development for the past two or three years, and all the machines now being built embody them. It is believed by the manufacturers that they give the fireman absolute and accurate control of the fire, and the results of service show that they enable him to make a considerable saving in the coal consumed.

Over 100 of these new type machines are now on order, or being applied to locomotives by the Locomotive Stoker Company, Schenectady, New York, which company controls the Street stoker.

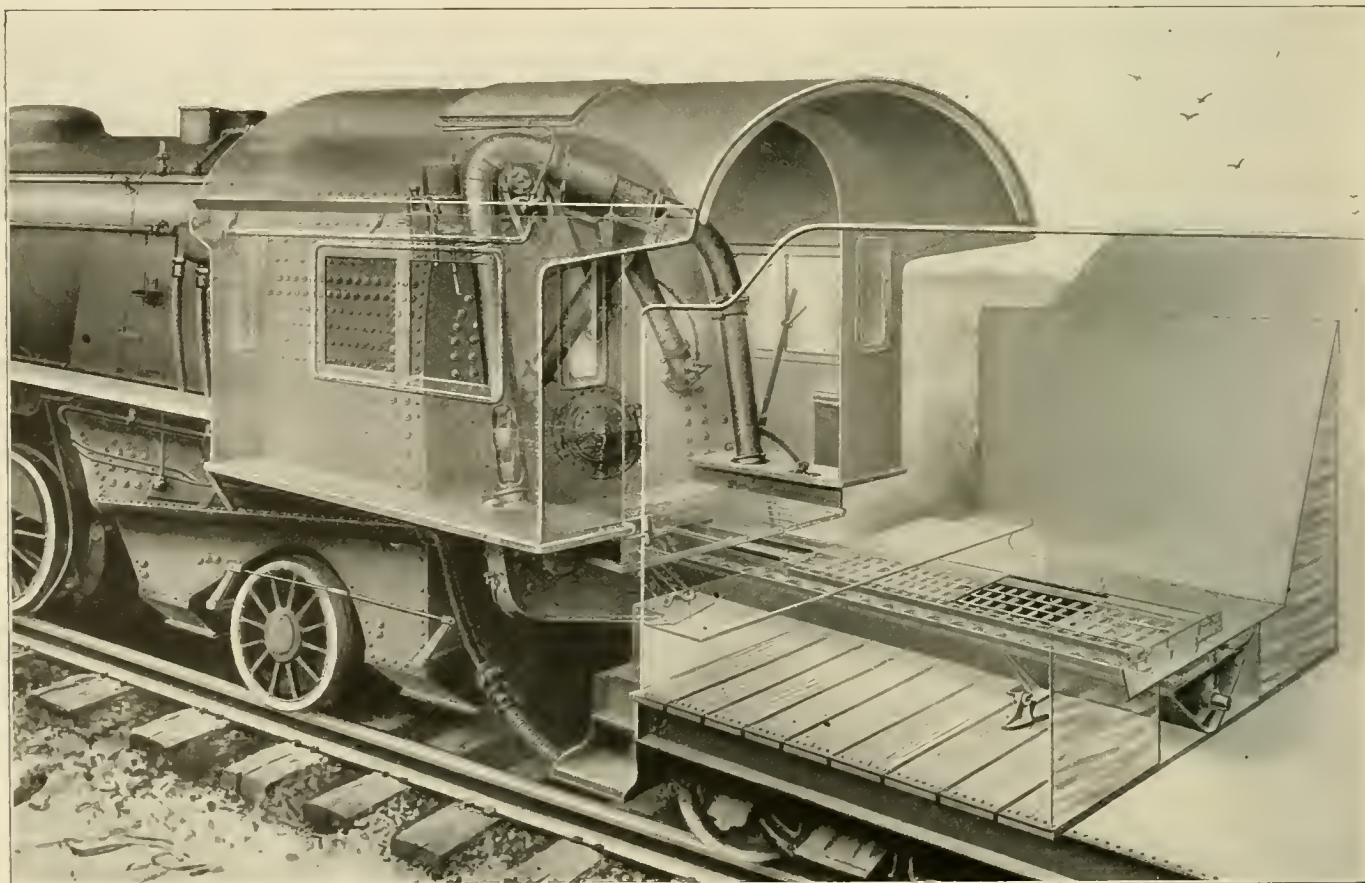

Street Type C Stoker Applied to a Locomotive

### CHRISTY STEEL FREIGHT CAR ROOF

A style of steel roof which a study of its design would indicate to be of ample strength and waterproof in every detail, has recently been placed on the market by the American Car Roof Company, Marquette Building, Chicago, Ill.

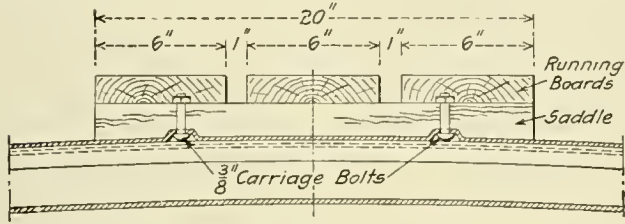

Section Through Carline Showing the Application of Running Board Saddle

It is made up entirely of pressed steel shapes, there being only five different shapes throughout the construction. The designers have so arranged their plans that this roof may be applied to any type of car with but few modifications. The photograph shows its application to the steel frame box

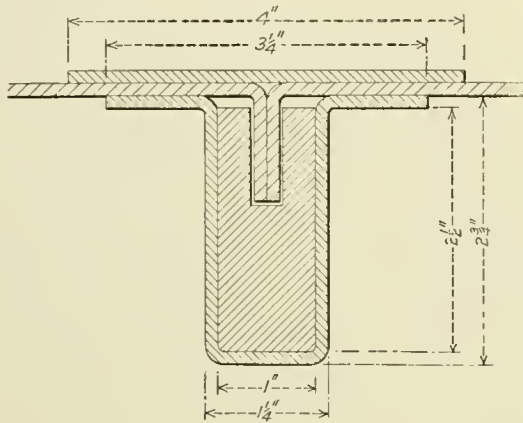

Longitudinal Section at Center of Car

car. Being made up of comparatively small units it should be an easy matter to renew any sheets or carlines that may become damaged.

The five different pressed steel shapes that are used are

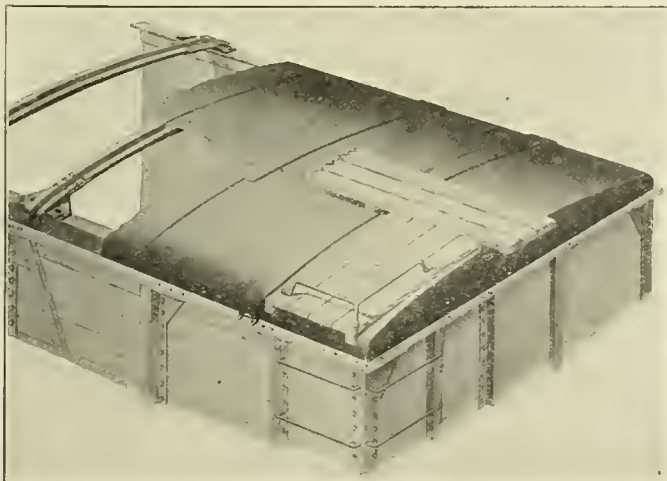

Christy Steel Roof Applied to a Steel Frame Box Car

the roof sheets, the carlines, the carline braces, the cap strips and a special Z-bar extending along the top of the car sheathing and the side plate. The roof sheets are rolled steel,

extend over the full width of the car and are flanged from 30 in. No. 14 gage steel. They have a pitch of 6 1/2 in. in 4 ft. 7 7/8 in. and are formed to a smaller radius at the ends to fit over the sides of the car. The roof sheet flange is 3/4 in. deep and rests in the carline, which is in the form of a flanged U-section.

The carlines are spaced 27 1/4 in. between centers for a 40 ft. car and are shaped to conform to the pitch of the roof.

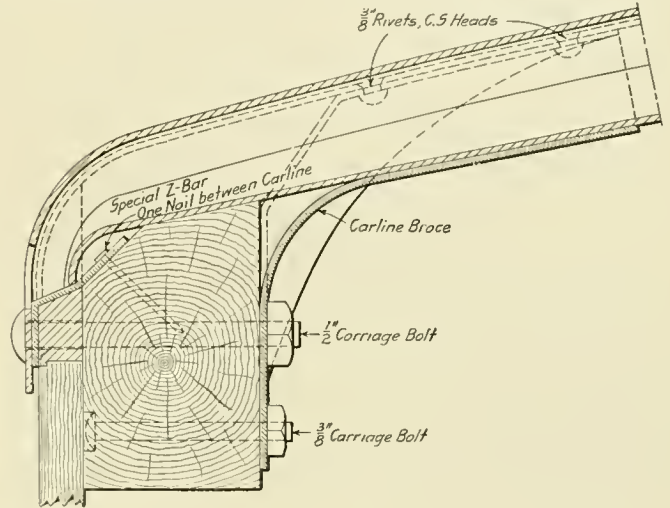

Section Through Carline at the Side Plate on a Wooden Frame Car

The method of supporting them at the side plates is clearly shown in the illustrations. The carline braces are riveted to the carline flanges by four countersunk rivets and are bolted to the side plate by two 1/2 in. and two 3/8 in. carriage bolts. A cast iron block 2 in. long placed in the carlines at the center of the car, is cut out to receive the flanges of the roof sheets and serves to keep them in alinement.

The cap strips are 4 in. wide by 1/8 in. thick. They hold

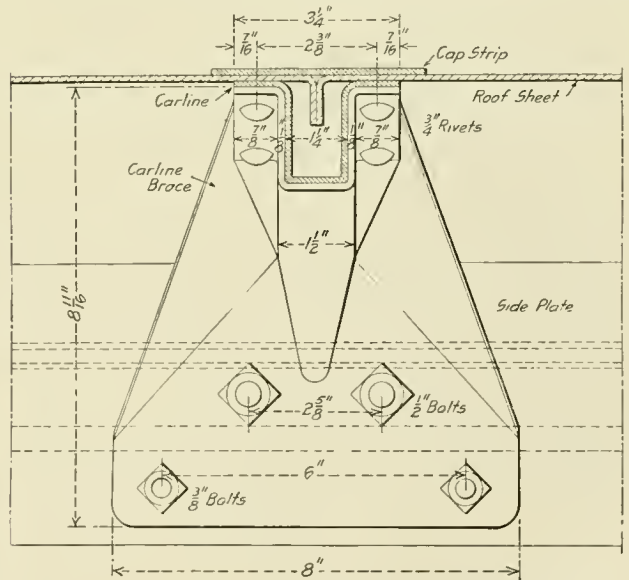

Section Near Carline Brace

the roof sheets in place, these sheets not being held by any other means. These strips extend from one side of the car to the other, extending over the joints of the sheets as shown, and are attached to the side plates by two 1/2 in. carriage bolts. The strips are deflected at the top of the car to receive the bolts for the running board saddle. The special Z-bar is placed at the side plate to give the necessary stiff-



ness to the side of the roof, and also performs a function in the waterproof features of the car.

As there are no holes made in the roof sheets, the only way for water to work its way through into the car is around the edges of these sheets. This has been taken care of by having the sides of the sheets drain directly into the trough of the carline, which, on account of its pitch, will drain any water that may collect to the sides of the car and allow it to escape through a  $1\frac{1}{4}$  in. by 1 in. hole in the cap strips provided for that purpose. The Z-bars at the sides of the car prevent water working up by the side plate.

This roof eliminates the use of purlins or a ridge pole, which, it is claimed, are not necessary with this construction. The roof was invented by Henry A. Christy, the inventor of the Christy grain door.

## STANDARD LOCOMOTIVE SCALE

A locomotive scale which permits of obtaining the individual wheel loads of a locomotive has recently been placed on the market by the Standard Scale & Supply Company, Pittsburgh, Pa. Separate scale beams are used for each wheel, and are ap-

plied as shown in the illustration. One of the chief advantages of the use of this scale is that no expensive foundation is required, and the locomotive may be weighed at any point on the line, as well as in shops. It is, however, essential that the road-bed be solid, and it is preferable to have a concrete base filling between the ties up to the base of the rail. By this method it is possible to determine whether any one pair of drivers has an excessive weight on the rail, and the scale can be used for checking up the distribution of the weight of the locomotive throughout the wheels. The scale beams are of simple construction,

the main lever projecting beyond the frame of the scale a sufficient distance to engage the locomotive wheel, the frame itself bearing on the base of the rail during the weighing.

The scale levers are of forged steel, and the weighing beam is graduated from 5,000 to 10,000 lb. in 50-lb. divisions. Weights are piled on the end of the beam for additional capacity. Each scale weighs approximately 450 lb., and is constructed for use on 80, 90 or 100 lb. rails. In weighing a locomotive the extreme end of the main lever is placed in its lowest position by operating the hand wheel under the weighing lever, the frame is placed upon the rail and leveled by the other hand wheel, to make the column plumb. To lift the locomotive wheel, the hand wheel under the beam is turned down until the weighing beam is balanced with the poise at the 5,000-lb. mark. The hand wheel develops 5,000 lb. pressure against the locomotive wheel in balancing the scale, so that loads less than 5,000 lb. cannot be read. When all of the wheels are raised a metal strip  $\frac{1}{4}$  in. thick should be passed between the top of the rail and the tread of the wheel, and a strip  $\frac{1}{8}$  in. thick between the gage of the rail and the flange of the wheel, in order to eliminate the possibility of friction preventing the free movement of the weighing beam.

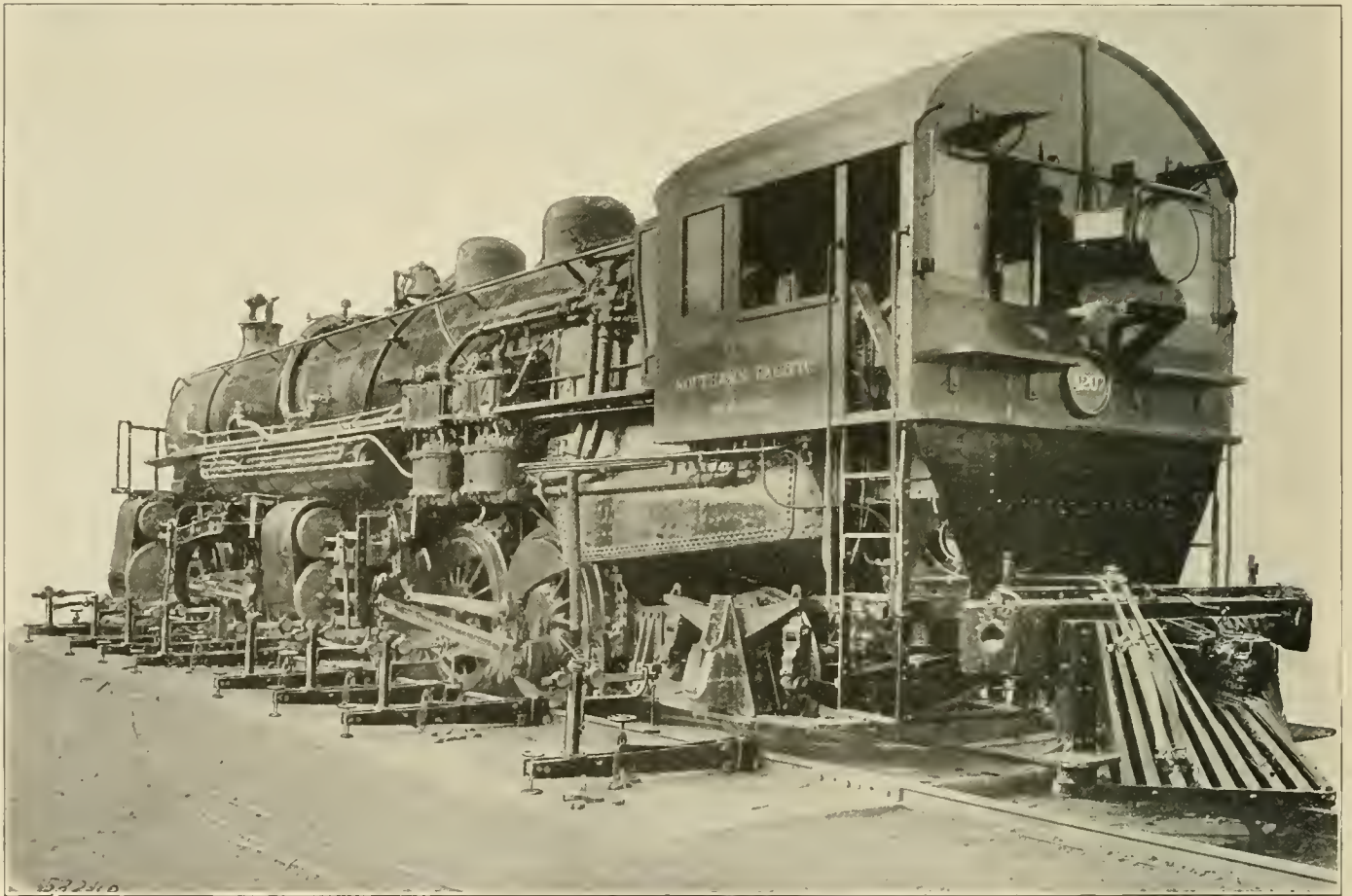

Standard Scales in Use for Determining Locomotive Wheel Loads

plied as shown in the illustration. One of the chief advantages of the use of this scale is that no expensive foundation is required, and the locomotive may be weighed at any point on the line, as well as in shops. It is, however, essential that the road-bed be solid, and it is preferable to have a concrete base filling between the ties up to the base of the rail. By this method it is possible to determine whether any one pair of drivers has an excessive weight on the rail, and the scale can be used for checking up the distribution of the weight of the locomotive throughout the wheels. The scale beams are of simple construction,

These scales are now being used by the Baldwin Locomotive Works, the Atchison, Topeka & Santa Fe, and other railways.

SHIPPING ON THE LAKE OF CONSTANCE.—The Austrian fleet on the Lake of Constance consists of six steamers of the value of about \$450,000. The importance of this branch of Austrian shipping is decreasing every year, and its bad financial results are ascribed to the recently introduced measures for the social welfare of employees and to excessive taxation.

### METAL CUTTING AND WELDING WITH OXYGEN AND PINTSCH GAS

Flame cutting and flame welding processes have helped to solve many problems that have been created by the increased use of metal construction in railway equipment.

After much careful research and development work, a metal cutting and welding torch has been developed by the Safety Car Heating & Lighting Company, 2 Rector street, New York. The possibilities in the use of Pintsch gas for high temperature flame work, and the availability of this gas in the railway field acateristic stability, or resistance to pre-ignition, is well suited were recognized as of value in the solution of the problem. Pintsch gas, on account of its high calorific value and char- for high temperature flame work. The numerous Pintsch plants or supply stations, located throughout the United States, Canada and Mexico, supplying gas to the railroads for car lighting

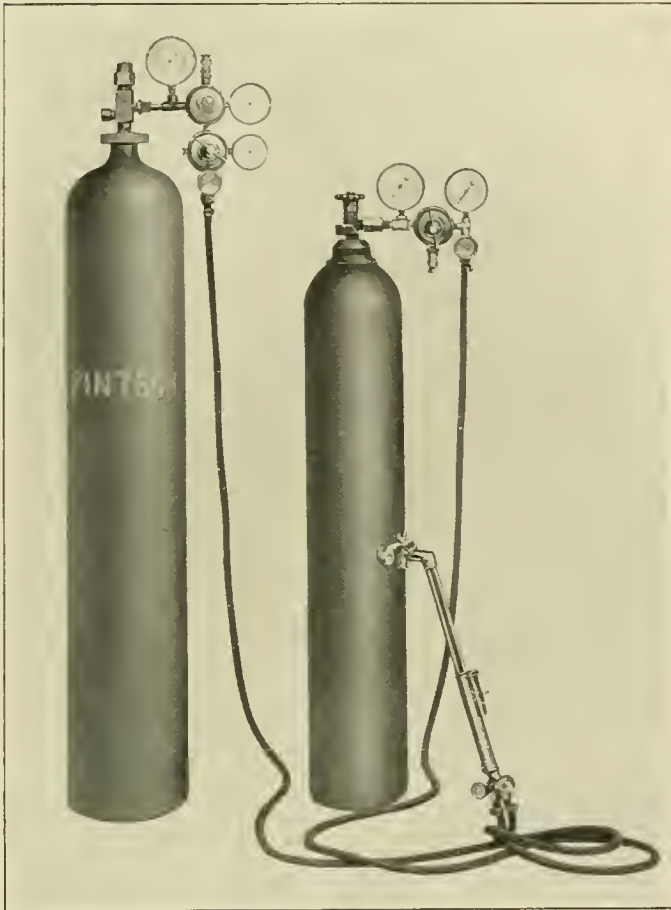

Oxy-Pintsch Metal Cutting Equipment

purposes, can deliver gas to the railway shops, or other points where needed, at a minimum cost and with minimum delay. A large number of the Pintsch supply stations are equipped to furnish Pintsch gas at 100 atmospheres pressure, so that the necessary quantity of fuel for cutting or welding can be furnished in the most compact form, which is another factor aiding in the low cost of metal cutting by this equipment.

The Oxy-Pintsch cutting and welding equipment is simple and compact. Pintsch gas, similarly to the oxygen used, can be supplied directly to the torch from either low pressure or high pressure flasks. The gas can also be distributed through the pipe lines operated by the Safety Car Heating & Lighting Company, to the points of consumption where practical. No expert knowledge is needed to properly handle the equipment. One of the illustrations shows the equipment complete, consisting of a high pressure Pintsch gas flask, an oxygen flask,

pressure regulators, hose to convey the Pintsch gas and oxygen to the cutting or welding torch, and the Oxy-Pintsch cutting torch. The gas pressure is in all cases reduced to the proper cutting or welding pressure by means of suitable regulators.

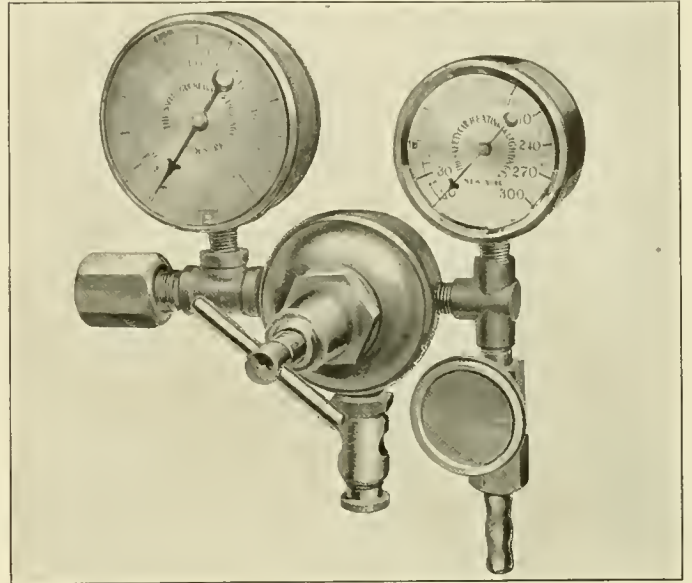

Oxygen Regulator

Pintsch gas is supplied in holders or flasks at either 12 atmospheres or 100 atmospheres pressure. The pressure reduction from the high pressure flask is made in two steps, insuring a uniform discharge pressure. The first pressure re-

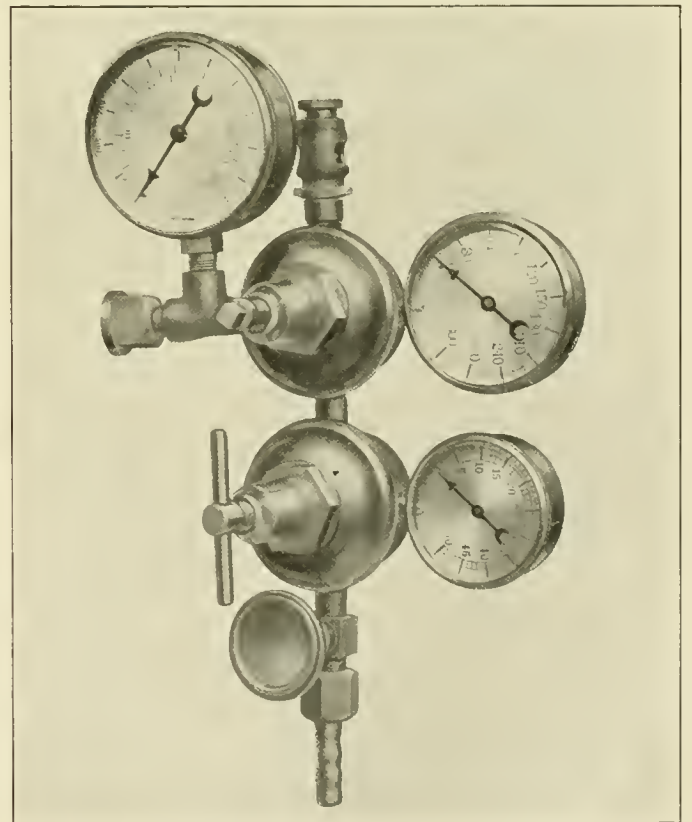

High Pressure Pintsch Gas Regulator

duction is made to 14 atmospheres, the regulator for this reduction being equipped with a safety valve which releases the pressure when 20 atmospheres is exceeded. The gas pressure



required at the torch for cutting or welding does not exceed 25 lb. per sq. in., which is obtained by means of the second pressure reduction. When Pintsch gas is taken from holders or pipe lines at pressures up to 14 atmospheres, an automatic low pressure regulator is used. This regulator is designed to maintain any desired uniform pressure reduction.

The oxygen is delivered at a uniform working pressure up to 150 lb. per sq. in. An automatic oxygen pressure regulator is employed, and is designed for the use of either high pressure or low pressure oxygen; it is equipped with a safety valve which releases when a pressure of 300 lb. per sq. in. is exceeded.

One of the engravings shows the Oxy-Pintsch cutting torch, model A. There are but two hose connections, one for Pintsch gas and one for oxygen. The Pintsch gas and oxygen for the heating flame are controlled by two lever valves, making a quick and accurate adjustment possible. The oxygen for the cutting is controlled by a third lever valve which can be readily opened or closed, as required, by a slight pressure of the

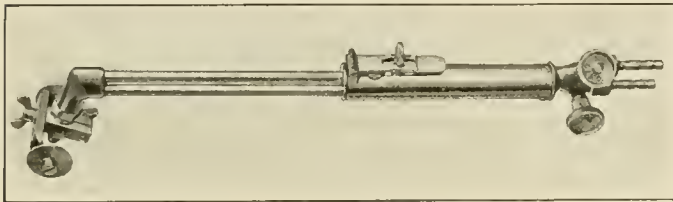

Model A Cutting Torch with Guide

thumb. The cutting tip of this torch is of annular form, with the oxygen cutting jet located centrally. Since the cutting jet is surrounded by the heating flame, it performs its proper function irrespective of the direction in which the cutting tip is advanced. This cutting tip also incorporates a novel design which causes the heating flame to develop inside of the tip. The heating flame, thus protected from the entrained air, is positive and effective in action, greatly facilitating adjustment for working conditions. The illustration shows the cutting torch equipped with a guide, the use of which is recommended wherever permissible as an aid to accurate cutting.

The model B Oxy-Pintsch combination cutting and welding torch is fitted with cutting and welding attachments, and has all the advantages outlined in connection with model A for metal cutting. The welding device illustrated can be used satisfactorily for repair work to castings or for welding steel or wrought iron of moderate thickness. In order to produce a

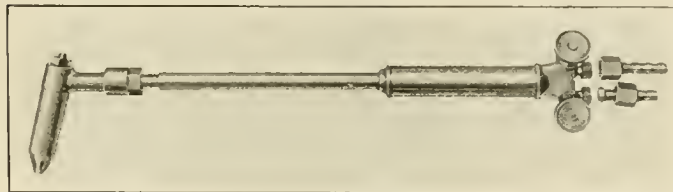

Model B Welding Torch

high temperature non-oxidizing flame, advantage is taken in this design of the principle of pre-heating the Oxy-Pintsch gas mixture. This is accomplished by means of a pre-heater, incorporated in the tip of the torch, performing its function by internal combustion. The gaseous mixture is pre-heated in this manner to a high temperature, to which is added the temperature of combustion, resulting in an effective high temperature welding flame.

The cost of cutting metal with the Oxy-Pintsch cutting equipment as compared with the cost of cutting by other methods demonstrates the advantage of this equipment in many branches of railway work. The saving effected is more fully appreciated by figures taken from actual service. In cutting with this equip-

ment through 25 ft. of 18 in. channel used in car construction, where the average thickness of the metal was 15/32 in., and the length of the cuts varied from 7/16 to 1 in., the cost per lineal foot of cut was \$.034, or a total cost of \$.862. The actual time consumed, including shifting the beam, was 33 minutes. The oxygen consumed cost \$.623, the Pintsch gas cost \$.018, and the labor \$.22.

The actual cost for similar work with the old process of chipping and drilling for the same total length of cuts was \$4.66. The cost of cutting with the Oxy-Pintsch equipment was thus less than one-fifth the cost of cutting by drilling and chipping.

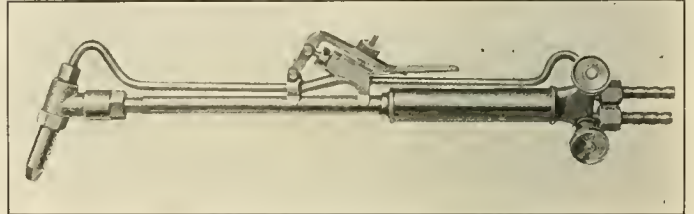

Model B Cutting Torch

The following table serves to illustrate what has been accomplished in cutting steel with the Oxy-Pintsch cutting equipment. The results given in this table were obtained under service conditions by means of hand cutting with the model A torch without a guide. Considerably better economy can be obtained where mechanical guiding is permissible:

Tip number	Thickness of steel	Pressure of oxygen, lb. per sq. inch	Pressure of gas, lb. per sq. inch	Cu. ft. of oxygen per foot of cut	Cu. ft. of gas per foot of cut	Time in minutes per foot of cut
1	1/4 in.	15	20	.53	.15	.70
1	1/2 in.	25	20	1.15	.20	.85
1	1 in.	35	20	1.80	.30	1.25
2	2 in.	40	20	4.10	.40	1.65

### SELLERS COUPLING NUT

An improved form of coupling nut for injector and valve connections is being introduced by William Sellers & Co., Incorporated, Philadelphia, Pa. This nut, it is claimed, eliminates the weak points and retains the advantages of the present forms of brass nut. It consists of a threaded ring of hard bronze provided with the usual internal collar to hold the brazing ring

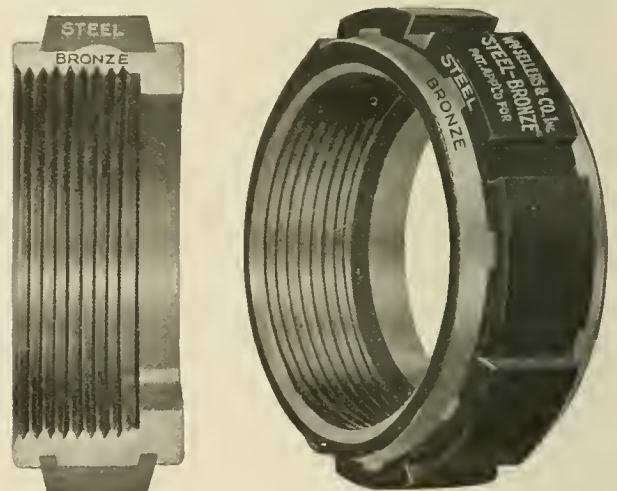

Sellers Coupling Nut for Injector Connections

or threaded union of the pipes to the injector or valve branch. Around this ring, dovetailed and keyed to it, is a heavy steel band with eight slots (two more than is usual), for the spanner wrench, permitting the wrench to be applied in any position of the nut, even in confined quarters. Inside the steel band are eight narrow slots which act as lateral keys, and also to tie the front and back of the nut together, strengthening the thread.

### WATER HEATER

A method of heating cold water at the point of delivery by steam, which is known as the Starwal system, has been placed on the market by Warner-Reiss Sales Company, St. Louis, Mo. The type B valve, which is illustrated, and which handles water in large quantities, may be found of advantage in engine houses for boiler washout work. The amounts of cold water and steam are regulated by separate valves so that any degree of temperature may be readily obtained. The construction of the type B heater is such that no sediment will collect in the valve itself.



Type B Starwal Water Heater

The steam is admitted through a conical step shaped casting perforated with small holes. This casting fits in a conical casting into which the cold water is admitted. The construction is such that any sediment that may collect on the delivery side of either the steam valve or the water valve will be readily washed out through the discharge.

Care should be taken in applying the valve so that the base of the conical casting will be on top. The steam as it comes through the small perforations in the conical casting mixes thoroughly with the water, heating it instantaneously to any

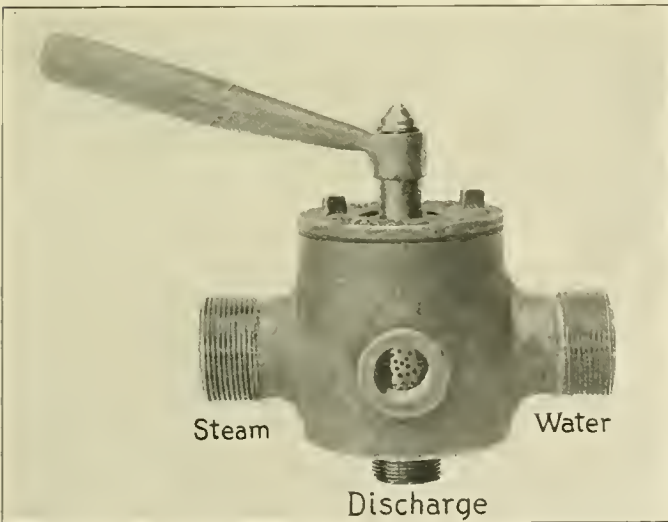

Starwal Heating Valve

degree of temperature desired. It obviates the necessity of maintaining large reservoirs for hot water. These heaters are made of cast iron and are adapted for all sizes of standard pipes.

One of the illustrations shows the Starwal heating valve, which is operated on the same principle as the Starwal heater. As the steam and water enter the valve they strike baffle plates and become thoroughly mixed. In this valve both the water and steam are controlled by a single handle. The first quarter turn of the handle discharges plain cold water; the

second quarter, warm; and the third, hot. The first quarter turn opens the water valve, the second partly opens the steam connection and holds the water valve open, the third partly closes the water valve and opens the steam valve entirely. This valve will be found of advantage in lavatories where hot and cold water are desired for washing purposes. It is also applicable to toilet rooms in cars, where the steam may be taken direct from the steam-heating lines.

### MACHINE FOR WASHING, DRYING AND IRONING BLUE PRINTS

The Revolute washing, drying and ironing machine, which is shown in the illustrations, is the result of long study and experimenting to produce a universal machine that will handle not only continuous blue print rolls, but separately cut sheets. The inconvenience of having to keep a machine of this sort continually "threaded" has been borne in mind, and in this design this objectionable feature has been eliminated.

In order to insure the prints being thoroughly washed, which is necessary in order that the chemical reaction may be complete and the prints permanent, a tank has been provided in which the

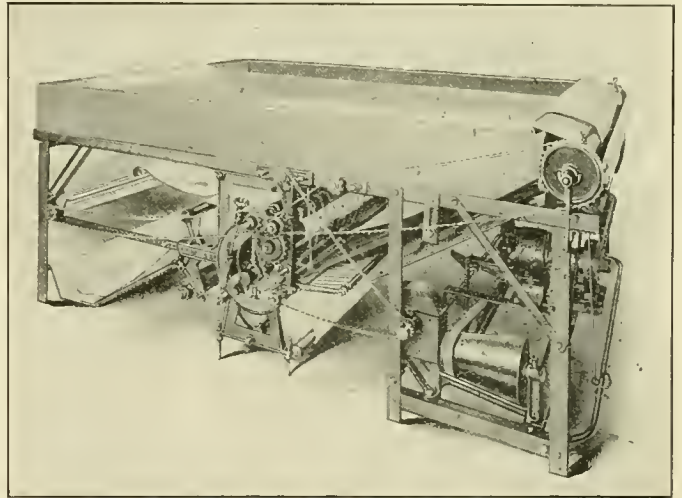

Revolute Washing and Drying Machine with Tank in Position

prints may be soaked for any desired length of time. A sufficient quantity may be put into the tank at one time so that some prints may always be ready for drying. When long rolls are being washed they are run through the tank continuously. The surface water is removed mechanically before attempting to dry the print, and the good quality of work is largely, due to the uniformity of the moisture in the print when it goes to the hot drum, and the fact that it is held securely against the hot drum while being dried. The surface of this drum is made absolutely true, insuring the prints being ironed out perfectly flat when delivered from the machine, a feature that is especially valuable in drying vandyke negatives.

The four principal features of the washer and drier are: A tank in which the prints are washed; a wringer which removes the surface water; a hot drum for drying and ironing, and an automatic winding up device for the long prints as they come from the drier. In the operation of the machine, the operator standing in front of the wringer, reaches over it to the tank, lifts the print by the edge, wetting the finger tips only, and lays it on the upper roller of the wringer, which is a 4-in. brass tube accurately ground. The lower roller is a steel shaft covered with felt, which bears against the brass tube, and removes the surface water from the print, at the same time allowing the print always to adhere to the brass roller.

A set of stripping fingers removes the print from the brass



roller and lays it on a set of traveling belts, which carry it to the hot drum, where it passes under a wide canvas belt to the surface of an 8-in. steel drum, accurately ground, and heated by either gas, steam or electricity. During three-quarters of a revolution the paper is held against the drum and dried and ironed. It is then stripped from the drum and deposited in a receiving trough at the end of the machine, or is rolled up in the automatic winding up device if it is a long print. The temperature of the drum and the speed of travel are varied to suit the weight of the paper being dried.

The machine is driven by a motor through a variable speed gear consisting of a belt running on two cones, driving the machine through a worm gear. The speed can be instantly changed by moving the lever. All rollers in the machine carrying any appreciable load are mounted on ball bearings. A foot

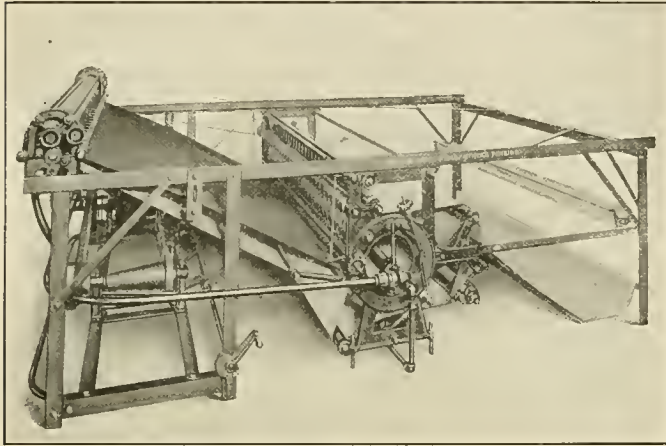

Washing and Drying Machine with the Tank Removed

treadle throws the wringer out of gear, and it may then be turned either way by hand in case a print should be started crooked.

This machine is manufactured by the Revolute Machine Company, 417 East 93d street, New York, and will run as a unit with any of that company's blue printers, for continuous printing, washing, drying and ironing. However, this is not recommended, as it is unlikely that the most economical speed of the blue print machine would be also the most economical speed of the washer and drier.

## OXY-ACETYLENE WELDING AND CUTTING TORCHES

Improved torches for cutting and welding by the oxy-acetylene process have recently been placed on the market by the Alexander Milburn Company, Baltimore, Md.

The principal claim made for the welding torch is the provision of a flame that is neither oxidizing nor carbonizing in its

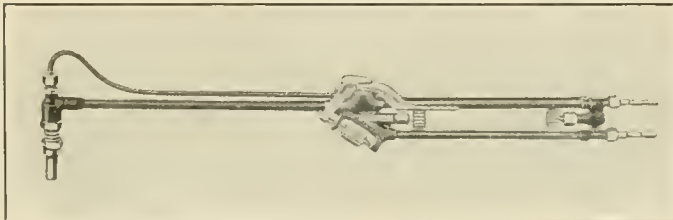

Cutting Torch

action. This is obtained by accurate proportioning and thorough mixing of the gases. To this end, both the oxygen and acetylene are controlled by needle valves within the handle, where they are reached with a slight movement of the operator's fingers

and are protected from accidental change through contact with the clothing. The mixing occurs throughout the long chamber leading to the head of the torch, and the two gases are brought to the same pressure and are completely intermixed before the tip is reached. This thorough mixing and special construction of the head minimizes flash-backs.

The cutting torch is designed for cutting operations only. The gases for the pre-heating flame are governed by needle valves, and are mixed in the same way as in the welding torch. The high pressure oxygen for the cutting jet is controlled through the lever on the handle, which operates against a diaphragm

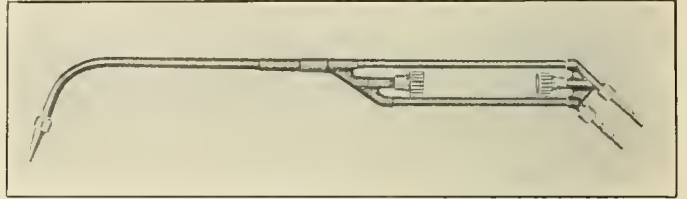

Welding Torch

valve. The gas pressure on the diaphragm normally holds the line open, leaving the operator's hand free. Pressure of the thumb on the lever cuts off the flow temporarily when required. A slight movement of the locking screw locks the lever in the closed position when it is desired to lay the torch down. The employment of a diaphragm eliminates the necessity of a stuffing box in the high pressure oxygen valve, and the attendant necessity of using a lubricant, which is a source of trouble with oxygen.

## PORTABLE MILLING MACHINE

A portable milling machine of substantial construction and provided with means for driving by motor, belt or hand, has recently been brought out by the Pedrick Tool & Machine Company, Philadelphia, Pa.

In order to introduce as little complication as possible, there

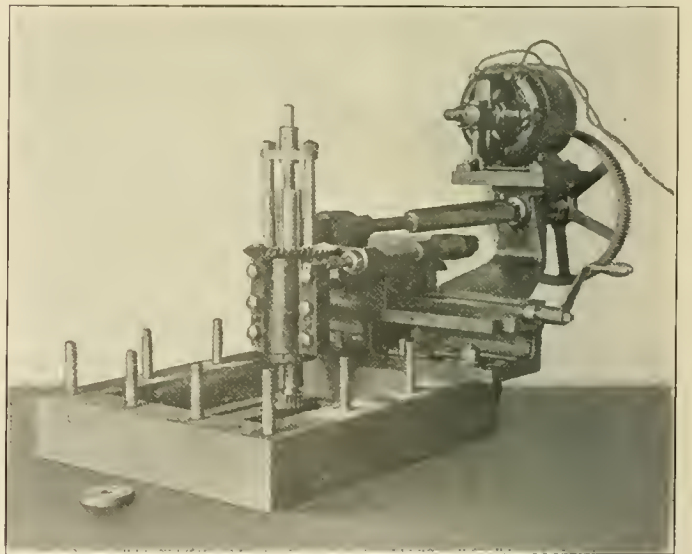

Portable Milling Machine

are no automatic feeds on the No. 1 machine, hand adjustment for the longitudinal and cross travels being provided. The No. 2 machine, which is considerably larger and is intended for a wider scope of work, has automatic feeds.

The bed has rib supports in the center and removable posts at both ends. These posts are made to take out, if necessary, when setting up the machine so as not to interfere with a wrench

when tightening holding nuts inside the base. In the base are numerous elongated slots to permit attachment of the machine to the work. An important element of the design is the fact that the machine will mill a surface level with that to which it is attached or several inches below, as in the case of a pump valve seat. When the cutter being used is no larger than the diameter of the spindle, it may be lifted out of the bearing with the spindle, and the cutter sharpened or a new one put on. This is accomplished by loosening two nuts. The spindle has a standard taper so that commercial cutters may be used. The telescopic drive shaft is made amply strong to withstand any work for which the machine is intended. The No. 1 machine will face a surface up to 12 in. by 8 in. and the spindle has a vertical adjustment of 6 in. Direct motor drive is arranged as shown in the engraving.

Besides the use of the machine for milling valve seats in pumps and engines, valve port edges, pads on large frames or housings, it may also be used for making keyways in shafts. While not particularly designed for the purpose, the machine may also be used for drilling.

### ELECTRIC THERMOSTATIC CONTROL OF STEAM HEATING

A system of automatically controlling the temperature in a passenger train car from the inside has been developed by the Gold Car Heating and Lighting Company, 17 Battery Place, New York, and is known as electric thermostatic control. It

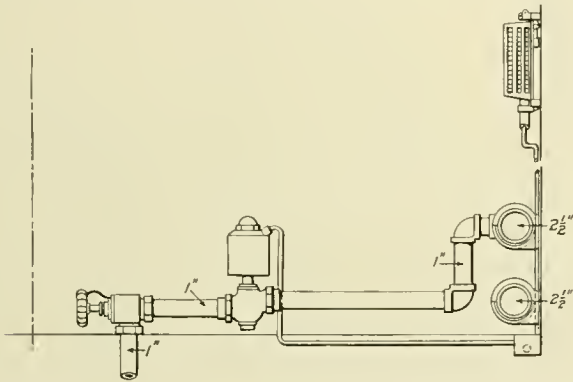

Application of Electric Thermostatic Control to a Passenger Train Car

is claimed that the apparatus will practically hold the temperature in the car constant. The system includes two special devices, an electric thermostat operating contacts by the expansion and contraction of a temperature-sensitive diaphragm and an electro-magnetic valve.

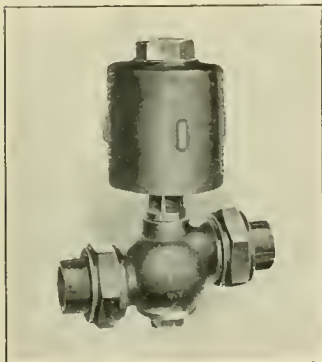

Electro-Magnetic Valve

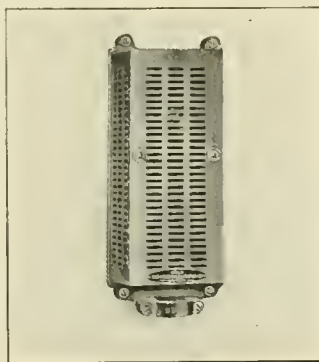

Electric Thermostat

The lowering in the car temperature by changes in the weather causes the thermostat to open the

valve and the warming of the car will operate to close the valve. The thermostat is usually placed in a convenient location on the wall near the middle of the car and the electro-magnetic valves are placed in the cross-over pipes on each side of the car underneath a seat, the three being connected by electric wires conveniently placed. The electro-magnetic valve is normally open. The electric current is very small and is obtained from the electric lighting circuit. It is claimed that there is a considerable saving in steam accomplished by the use of this system, either in connection with straight steam or with plain vapor systems. It is said that in the heating of cars in terminal yards tests have shown a saving of from 50 per cent to 75 per cent.

### PORTABLE ELECTRIC HOIST

A portable electric hoist which has been developed by the Northern Engineering Works, Detroit, Mich., is shown in the accompanying illustration. Every means has been taken to make the moving parts of the hoist as light as consistent with its capacity. Efforts have also been made to keep the number of parts as small as possible, in order to provide a hoist of simple construction and easy maintenance. All forms of planetary, or worm or bevel gear combinations have been avoided,

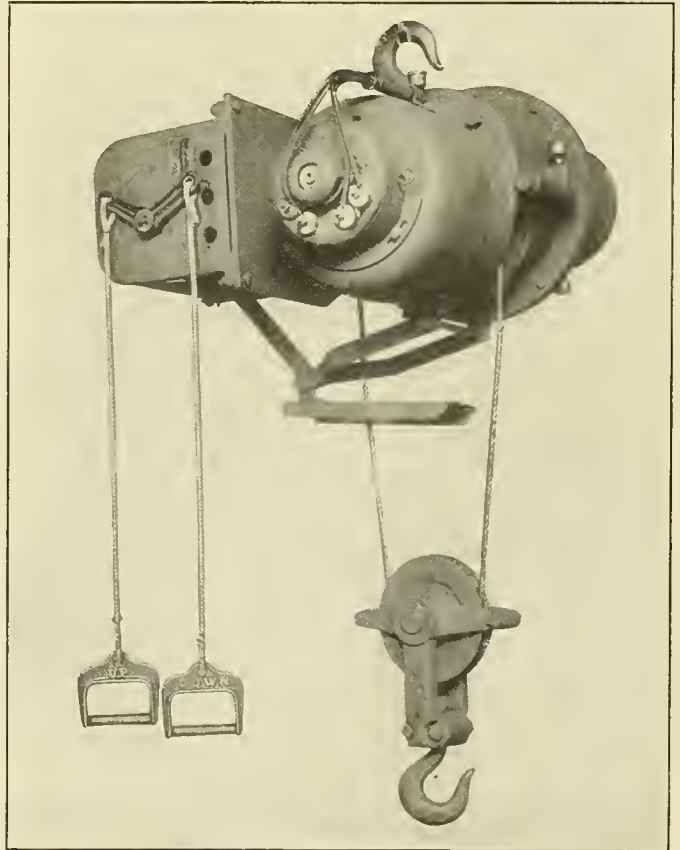

Northern Type D Portable Electric Hoist

and standard cut spur gears are used throughout the transmission.

The hoist is suspended by a single hook, and may be used at any place where a hand hoist would be used. It occupies but little more space than a hand hoist and has a speed many times greater. All the gears are enclosed completely for internal lubrication, and the mechanical disc brake is used. Bronze bushings are used throughout and all the gears are heat treated and hardened forged steel. A smooth-faced drum with wide spool flanges is employed instead of the grooved



drums, which eliminates the cutting of the rope due to the tipping of the hoist. Either alternating or direct current motors may be used, and the controllers may be furnished with or without a graduated speed resistance controller. In the construction of these hoists the interchangeability of the parts has been made a careful study. The standard sizes of the type D electric hoist, shown in the illustration, range from 1,000 to 12,000 lb. capacity. This hoist may also be attached to any standard trolley.

### LINK GRINDING MACHINE

The 11,000 lb. link grinder shown in the engraving was designed and built by the Newton Machine Tool Works, Inc., Philadelphia. The links are located on the fixture mounted on the table. The radius is gaged from the center of the link to the center of a pivot at the rear of the machine and is measured by a scale. The maximum capacity is a link of 100 in. radius and of an approximate length of 42 in. To insure central location of the work table while changing the radius for the various size links, pins mounted on both ends are temporarily inserted in hardened steel bushings in the cross slide.

After the machine is started, the hand operated clutch con-

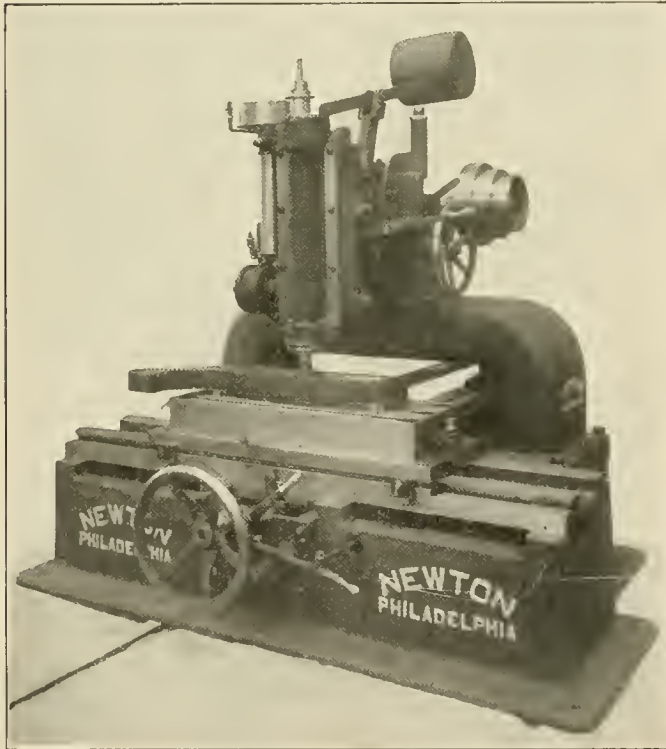

Link Grinding Machine of Substantial Construction

trolling the reciprocation of the saddle is engaged, and the main saddle is then lowered by means of a hand wheel until the emery wheel is in the proper relative position to the face to be ground. During this operation the main saddle feed is made inoperative through a latch lever holding the feed operating clutch neutral.

When the small diameter narrow face wheels are used, the reciprocation clutch and the neutral feed latch are disengaged and the constant feed to the main saddle is operative. Motion for this feed is taken from a cone on the main driving shaft and through a double train of bevel gears to give reverse motion. The length of feed is controlled by trips which are so arranged that the direction of movement of the saddle is automatically reversed. To avoid undue dwell at the end of the stroke a spring roller latch is employed.

After locating the grinding wheels the trips on the cross slide

are adjusted for the length of the travel. These engage a pawl, the action of which is quickened by a spring roller latch to reverse the direction of travel. A lever permits of stopping the table at any desired point, and another lever controls the neutral latch for the table mechanism. The hand wheel shown at the bottom of the machine controls the in-and-out adjustment of the bottom saddle for the depth of cut. This also provides hand cross motion of the slide.

To permit the work table to follow the radius being ground, a table clamp is pivoted to the cross slide. As the radius bar is attached directly to the other slide, adjustments for depth of cut and from side to side of the link are made without disturbing the radius and parallel radii may be ground without resetting the work.

The spindle of the machine varies from  $2\frac{1}{8}$  in. to  $2\frac{1}{4}$  in. in diameter, and is supported on self-centering ball and taper roller bearings with take-ups, which eliminates wear of the spindle. The spindle speeds range up to 5,000 revolutions per minute. On account of the difference in weight of the saddles the connecting of the one weight to each of these has been made through a horizontal compensating link.

### CUTTING OFF AND REAMING MACHINE FOR PIPE AND TUBES

A machine for cutting off and reaming all sizes of pipe and tubes up to 2 in. has recently been developed by the Oster Manufacturing Company, Cleveland, Ohio. This machine is provided with a large single wheel tube cutter which is stationary and is mounted on a steel pinion resting in a bronze bearer. The pipe to be cut off rests on a pair of rollers and by

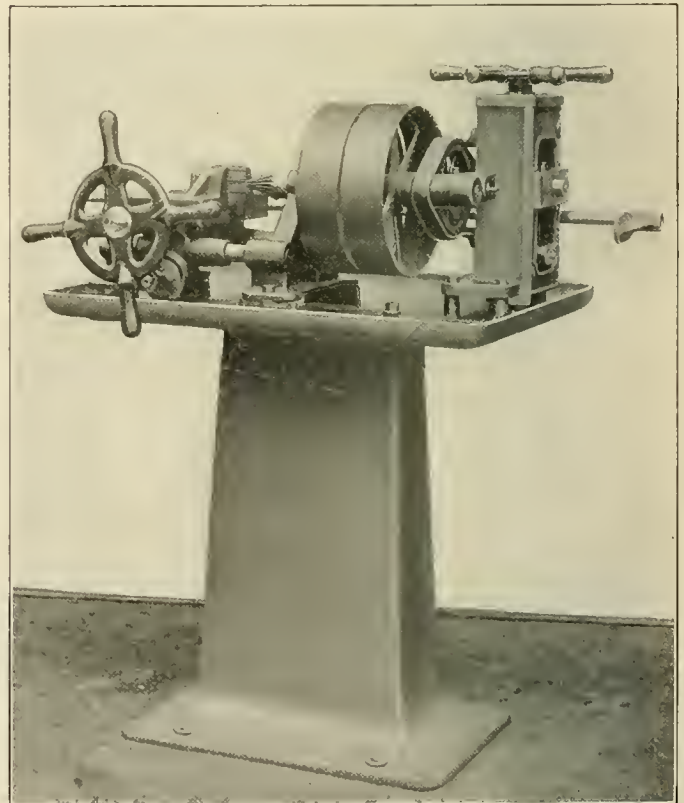

Oster Cutting Off and Reaming Machine for Pipe and Tubes

a turn of the hand wheel at the top of the machine is brought in contact with the cutting disc. The speed of cutting off is regulated by a slight pressure on the hand wheel. The rollers which support the pipe rest on the bottom of a yoke which slides up and down in the frame. The disc cutter can easily be removed

for sharpening or renewal. The gage rod is adjustable for the different lengths of pipe to be cut. In reaming, the pipe is held in the vise jaws shown, which are opened or closed by a movement of the hand wheel at the side of the vise. This open vise facilitates the quick changing of work. The pressure of the pipe against the reamer is brought about by a slight pressure on the handle mounted behind the vise wheel. This handle also moves the vise back and forth. The reamer is held in place by a set screw and can easily be removed for sharpening when necessary.

### CLOCK ATTACHMENT FOR BOYER SPEED RECORDERS

An improvement in the present Boyer speed recorder has been made in the shape of a clock attachment by which it is possible to record the time by means of a curve in a manner similar to the recording of the speed. This clock attachment forms a part of the speed recorder itself and is enclosed in the hood that covers the machine. The new speed recorded differs from the original in no way other than in the addition of the clock attachment. The pencil for the time curve is driven by a cam G, as shown in the illustration, which makes a complete revolution every hour. The pencil moves vertically and is so adjusted as to travel  $1\frac{7}{8}$  in. down and  $1\frac{7}{8}$  in. up for every complete revolution of the cam, or for every hour. This gives a minute space of  $1/16$  in., and as the chart is ruled by horizontal lines spaced  $5/32$  in. apart, one line being a heavy line and the other dotted,

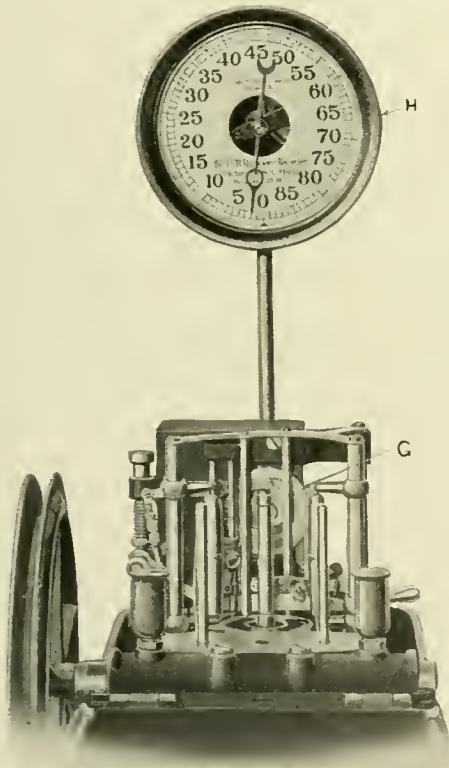

Boyer Speed Recorder with Clock Attachment

the distance between the heavy lines represents five minutes. In order to avoid confusing the speed curve with the time curve, the time pencil has been located  $1\frac{1}{2}$  in. in advance of the speed pencil.

The accompanying chart is a typical record taken with this new recorder. The mile posts, or the vertical lines, are numbered from 0 to 28, inclusive. The horizontal lines are lettered in this case simply to facilitate the description of the operation of the new recorder, a point on the chart being represented by a

letter and figure. The interpretation of this chart is as follows: The engine was in the roundhouse at 4:05 p. m., the clock pencil being at R-6, while the speed pencil was at S-3. The point R-6 was then marked 4:5 p. m. by the inspector, and the top of the recorder was then closed and locked. From the engine house the engine was backed down to its train, a distance of three miles. The time it left the roundhouse is shown by the point L-6, which being three spaces down from R-6 indicates that it was 15 minutes before the engine left the engine house after the inspector had set the time pencil. The engine arrived at the terminal at 4:32½, being 12½ minutes on the road. While at the terminal the time pencil traveled from G-3 to F-3, then to R-3 and back to P-3, indicating that the engine was idle 37½ minutes, and that its leaving time was 5:10 p. m. On pulling out, the speed of the engine was increased in two miles to 40 m. p. h. This speed was maintained but 3½ miles, as there was a slow order between mile posts 6 and 7, on account of which the en-

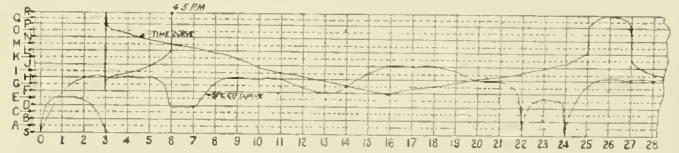

Diagram Made by the Boyer Speed Recorder with Clock Attachment

gineer slowed down to 20 m. p. h., as shown between D-6 and D-7.

The speed was again increased to 40 m. p. h., which speed was maintained until 11 miles out, or at 8:11. A grade of 2½ miles slowed the train down to 30 m. p. h. From the time curve the foot of the grade was reached about 5:27½ p. m. On starting down the other side of the grade the speed was increased until at 16 miles from the terminal 50 m. p. h. was reached. Twenty-one miles out the engineer shut off and coasted, then applied the air, and came to a full stop. The time curve then showed that he was held 10 minutes, as shown by the points L-25 and P-25. The engine was started at 6 p. m. and ran two miles to the station, where a 10 minute stop was made. The station was left at 6:17½ p. m.

With this attachment it is now possible by means of the Boyer speed recorder to record the speed in miles per hour at all points of the trip, the total mileage between any points, the actual running time between points, the total time on the road, the time and location of each stop or slow-down, the time consumed at each stop, and the time and location of each brake application. By means of this device it is possible to tell in detail the movement of a train over a division, and a positive check on the operation of the train is provided.

The Boyer speed recorder is sold by the Chicago Pneumatic Tool Company, Chicago.

### CONSTANT SERVICE WHEEL TRUING BRAKE SHOE

All locomotive and motor driving wheels sooner or later become grooved or form a false flange in service on account of the wear of the tire on the rail. This is especially noticeable on roads where sand is freely used. When the limit of permissible tire wear is reached the wheels must be removed and the tires turned or ground true.

In order to overcome this trouble, a constant service brake shoe, which, it is claimed, trues and keeps true driving wheel tires, has been developed by the American Abrasive Metals Company, New York. Feralun is the material used. The shoe is made with pieces of alundum cast in that portion coming into contact with the wheel tread surface where the false flange usually forms. The balance of the shoe surface in contact with the tire is the usual iron brake shoe mixture. Additional alun-



dum is put in that portion of the shoe bearing on the true flange to prevent its wearing too long. The wear on the tire is not increased; it is merely adjusted to keep the tire free from false flanges. As soon as the false flange in contact with the abrasive material is reduced, the abrading action practically ceases and the wear on the wheel is then, it is claimed, only what it would be with an ordinary shoe.

Alundum now utilized for this purpose in the Feralun shoe is made in electric furnaces and contains no water of crystallization; it, therefore, does not shatter when the hot iron is

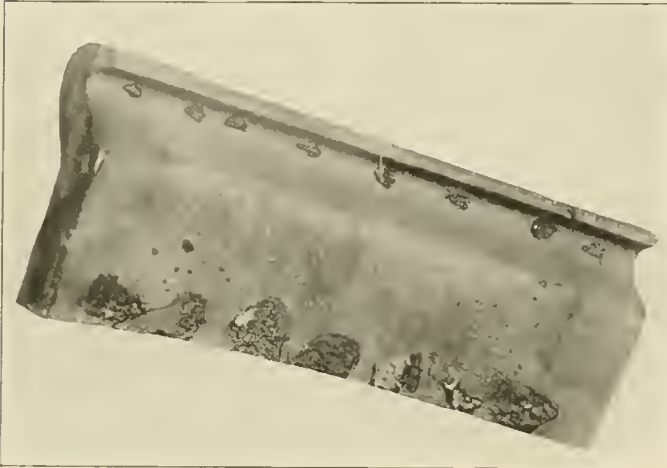

Wheel Truing Brake Shoe

poured over it in the mold. It is also claimed that it is excelled in hardness only by the diamond and is very strong mechanically, and that it overcomes the faults inherent in the minerals heretofore tried and enables the production of a service shoe that will keep wheels true, or make them true if false flanges have already formed. These shoes are now in use on standard and narrow gage locomotives and motors of over 100 railroad and mining companies.

## SAFETY WRENCH FOR HOPPER CARS

An automatic safety wrench for opening the doors of hopper, drop bottom or side dump cars is being manufactured by the Hess-Steel Castings Company, Witherspoon building, Philadelphia, and is shown in the illustrations. As will be seen from the line engraving, there are two pawls, either of which can be thrown

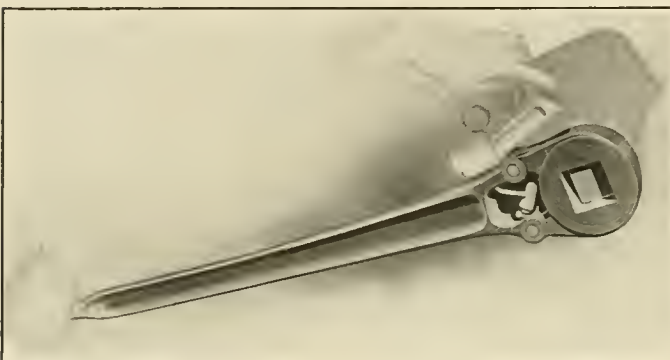

Safety Wrench for the Doors of Hopper and Drop Bottom Cars

into or out of engagement, according to whether it is desired to open or close the doors, by means of the reversing attachment. To open the door of a car the wrench is placed on the square end of the hopper shaft and the small handle of the reversing device set upward. The upper pawl is then pushed into engage-

ment with the ratchet, by the thumb, and at the same time the handle is raised to hold it so. The wrench is then lifted until the pressure is taken off the car dog. With the wrench held firmly in this position the car dog is then lifted while the wrench is lowered quickly. This latter operation causes the upper pawl to spring out automatically, allowing the door to drop. In case the door sticks, it can be forced open by raising the handle

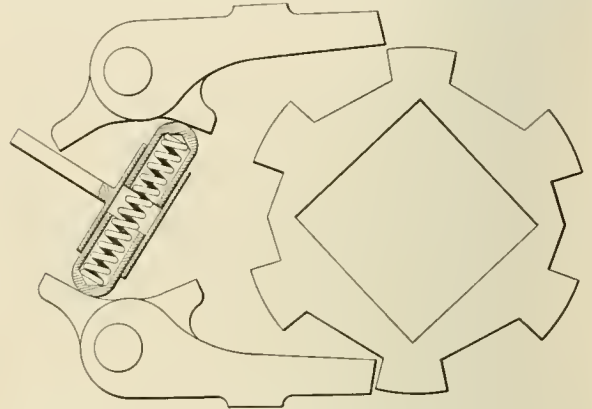

Arrangement of the Working Parts of the Safety Wrench

engaging the lower pawl and then forcing the handle of the wrench down. In closing the door, the small handle of the reversing device is set downward, throwing the upper pawl into engagement. The door is then closed by means of the ratchet.

## ASBESTOS CARLINING

An asbestos carlining is being furnished by the Franklin Manufacturing Company, Franklin, Pa., for the insulation of steel passenger train cars. This is composed of asbestos fiber made up in standard size sheets, and besides being fireproof it is claimed that it is vermin proof and will not disintegrate and shake down from the sides of the car. It is light in weight and easily applied. One large railway now using the material is applying it by using a common car paint, thickly mixed, to which is added a small quantity of iron oxide. One coat of this is applied to the material and one to the steel sheet, gluing the carlining to the sheet firmly. It is also stated that this lining is an excellent non-conductor and that repeated tests have shown the insulation qualities to be high.

AMERICAN LOCOMOTIVES FOR AUSTRALIA.—The government of the commonwealth of Australia has recently placed an order for four locomotives for the Transcontinental Railway, now under construction, with the Baldwin Locomotive Works. Such action caused serious debate in the Federal Parliament. The Assistant Minister of Home Affairs has therefore issued the following statement: Every manufacturer of engines in Australia was approached, to ascertain if they could be supplied in Australia. Without exception, the firms replied that they could not give speedy delivery. He then decided to invite quotations for quick supply from over-sea firms. The Baldwin Company of America, made the most satisfactory offer. The price of the Clyde Engineering Company for engines of this type was \$30,148, but these American engines were costing \$23,573 at Port Augusta, or \$25,305 at Kalgoorlie; the question of price, however, did not enter into the case. The need for speedy delivery is that for every 50 miles of track laid an engine is required, and the tracklayers are putting down 1½ miles a day, so that a locomotive is required at each end of the railway every 2½ months. Inquiries were made of over-sea firms doing business in Australia, and the representatives of Baldwin's offered to ship the engines from the United States in 15 weeks. British and Scottish firms wanted 11 or 12 months.

# NEWS DEPARTMENT

The Erie Railroad has announced that beginning April 15, its Ohio division will operate on eastern standard time instead of central standard time, as at present.

The shops of the International & Great Northern at Palestine, Texas, have been closed, with the exception of the car department, for an indefinite period.

The coach shops of the Oregon Short Line at Ogden, Utah, were closed indefinitely on April 1. Seventy-five men had been employed at these shops. Some of the work heretofore done at Ogden will be transferred to the shops at Pocatello, Idaho.

R. E. Trevithick, grandson of Richard Trevithick, the inventor of the first locomotive to run on rails, has been in this country for the past few months making a tour of inspection of American railroads. Mr. Trevithick has recently completed a course at the Crewe works of the London & Northwestern. He is the son of A. R. Trevithick, superintendent of the wagon department of the London & Northwestern at the Earlstown works, Crewe, Eng.

## SPECIAL TRAIN TO ATLANTIC CITY CONVENTIONS

The "Master Car Builders Special," via the Pennsylvania Lines, will leave Chicago, Union station, at 3 p. m., Monday, June 8, reaching Atlantic City about 2 o'clock the following afternoon. This train will be composed of Pullman, electric lighted, steel cars—library, smoking, sleeping and compartment observation cars, with Pennsylvania diners serving table d'hote dinner leaving Chicago, and a la carte breakfast and luncheon the following day.

The summer tourist fare from Chicago to Atlantic City will be \$29.50 for the round trip, good to return within 30 days. Those who desire to go to New York after the convention can purchase summer tourist tickets from Chicago to that point for \$30, good to return within 30 days and deposit them for stop-over of 10 days at Philadelphia, purchasing round trip tickets for \$2.50, Philadelphia to Atlantic City and return. The date of deposit counts as one day. Those desiring to return via Baltimore and Washington can do so, obtaining stop-over of 10 days at those points, Harrisburg and Pittsburgh, not exceeding the final limit of the ticket, by so specifying at the time of purchasing tickets and by depositing them at stop-over points immediately on arrival, date of deposit to count as one day.

Accommodations can now be reserved at the city ticket office of the Pennsylvania Lines, 242 South Clark street, Chicago, and will be held until June 1, by which time they must be claimed, or by letter to E. K. Bixby, district passenger agent, Pennsylvania Company, Chicago.

## MEETINGS AND CONVENTIONS

*May Conventions.*—The Air Brake Association; the Railway Storekeepers' Association; the International Railway Fuel Association and the Master Boiler Makers' Association hold their annual conventions during May. The place and date of meeting and the subjects to be considered by each of these associations are given in this issue.

*Air Brake Association.*—The twenty-first annual convention of the Air Brake Association will be held at the Hotel Pontchartrain, Detroit, Mich., May 5-8, 1914. The subjects are as follows: Electro-Pneumatic Signal System for Passenger Trains, by L. N. Armstrong; Air Hose, by T. W. Dow; Clasp Type of Foundation Brake Gear for Heavy Passenger Equipment Cars, by T. L. Burton; Air Gage and Conductor's Valve in Caboose Cars,

by Mark Purcell; Analysis of the Factors Involved in Controlling and Stopping Passenger Trains, by Walter V. Turner; 100 Per Cent. Efficiency of Freight Train Brakes, by Fred von Bergen; Recommended Practice, S. G. Down, committee chairman; Topical Subjects, Mountain Grade Work, by H. H. Forney, and Modern Train Building, by George W. Nolan. Among the entertainment features of the convention will be a "Manufacturers' Exploitation Meeting." One afternoon will be set aside for the members to assemble in the convention hall, where each exhibitor will be given from 15 to 30 minutes in which to exploit, by discourse, charts or lantern slides, or in any manner he chooses, the product or device which he desires to place before the assemblage. The executive committee inaugurates this convention novelty, believing that it will assist the booth exhibits, and also give the members an orderly account of what the exhibitors are contributing to the air brake art.

*Railway Storekeepers' Association.*—At the eleventh annual convention of the Railway Storekeepers' Association, to be held at Washington, D. C., in the Hotel Raleigh, Monday, Tuesday and Wednesday, May 18, 19 and 20, 1914, the following will be the official program:

### MONDAY, MAY 18

9 A. M.—Enrollment, convention hall.

10 A. M.—Convention called to order. Invocation by the bishop of Washington, the Right Reverend Alfred Harding; address of welcome, Oliver P. Newman, commissioner of the District of Columbia; address, the president of the association; address, Fairfax Harrison, president, Southern Railway; report of the secretary-treasurer; report of the accounting committee.

12:00.—Adjournment.

1:15 P. M.—Auto busses will be in readiness at the hotel entrance to take members of the convention to the White House, where they will be received promptly at 2 by the President of the United States.

2:30 P. M.—Convention picture in front of the White House; as soon as the picture is taken busses will convey the members back to the hotel.

3:00 P. M.—Convention session; subject K-1, Stores Department Expenses, E. L. Fries; report, Tinware Committee; report, committee on Book of Standard Rules.

5:30 P. M.—Adjournment.

8:00 P. M.—Convention session. Ladies attending the convention will be taken to the Congressional library; meet in convention hall.

10 P. M.—Adjournment.

### TUESDAY, MAY 19

9 A. M.—Convention called to order; continuation of report of committee on Book of Standard Rules; subject K-3, Handling of Stationery, S. G. Pettit; report, Piece Work Committee.

9:30 A. M.—Auto trip to the principal buildings and statues in the city for the ladies of the convention.

12:30 P. M.—Adjournment.

2:00 P. M.—Auto busses will leave for steamer to Mt. Vernon.

2:30 P. M.—Steamer leaves pier, foot of Seventh street.

3:40 P. M.—Arrive Mt. Vernon. The president of the association will place a wreath on the tomb of General George Washington.

5:00 P. M.—Steamer leaves Mt. Vernon.

5:15 P. M.—Arrive Marshall Hall, Md., where a genuine Potomac river supper will be served in the dining hall. The hall will accommodate 200, so it will be necessary to have two



tables, the first at 6 o'clock, the second at 7; dancing in the dancing pavilion.

7:45 P. M.—Steamer sails for a trip on the river, arriving in Washington about 10:00 p. m. Auto busses will meet the steamer at the pier and take members of the convention to the Hotel Raleigh. This trip is under the auspices of the Chamber of Commerce of Washington. It will be necessary that members wear their badges, as the badges will be the sole means of identification.

WEDNESDAY MAY 20

9 A. M.—Convention called to order; report, committee on Recommended Practices; report, Scrap Committee; subject K-2, How to Obtain the Greatest Efficiency from Employees in the Stores Department. E. J. Roth and W. D. Stokes; report, committee on Standard Buildings; report, committee on Couplers and Parts; report, Membership Committee; subject K-4, Classification of Electric Railway Materials; committee on Resolutions; election of officers; adjournment.

*International Railway Fuel Association.*—The sixth annual meeting of this association will be held at Hotel La Salle, Chicago, Ill., May 18 to 21, 1914. The executive committee has selected a list of subjects upon which papers are being prepared that should be of mutual interest to representatives of coal companies and railroad companies. The subjects are as follows: Storage of Coal—Its Feasibility and Advantages to Producer, Carrier and Consumer; Sizing of Coal for Locomotive Use; A Uniform Method of Computing Locomotive Fuel Consumption for Office Statistics and Trip Performance; Honeycombing and Clinker Formation; Coal Space and Adjuncts of Locomotive Tenders; Relation of Front End Design and Air Openings of Grates and Ash Pans to Fuel Consumption and Sparks; Economies in Roundhouse and Terminal Fuel Consumption; Pre-heating of Feed Water for Locomotive Boilers.

*Master Boiler Makers' Association.*—The eighth annual convention of the Master Boiler Makers' Association will be held at the Hotel Walton, Philadelphia, Pa., May 25, 26, 27 and 28. Committee reports will be presented on the following subjects: Advantage or Disadvantage of Oxy-acetylene and Electric Processes for Boiler Maintenance and Repairs, F. A. Griffin, chairman; What Benefit Has Been Derived from Treating Feed Water for Locomotive Boilers Chemically?, T. F. Powers, chairman; What Can the Association Do to Get a Uniform Rule Regarding the Load Allowed on Staybolts and Boiler Braces?, C. P. Patrick, chairman; Advantages or Disadvantages of Flexible Staybolts to Be Used in Crown Sheets to Take the Place of Sling Stays, C. E. Steward, chairman; Advantage or Disadvantage of Combustion Chambers in Large Mallet or Pacific Type Engines, Other Than a Shorter Flue, A. N. Lucas, chairman; What Shape and Size of Head of Radial Staybolt in Crown Sheet of Oil Burning Engines Gives the Most Efficient Service?, C. L. Hempel, chairman; Does the Method of Flue Cleaning or Rattling Have Any Effect on the Further Scaling Up of Flues?, B. F. Sarver, chairman; Combustion and Fuel Economy, C. F. Petsinger, chairman; Proper Inspection of a Boiler While in Service, C. E. Fourness, chairman; Law, W. H. Laughridge, chairman. The first day of the convention will be taken up by addresses and the general business of the association.

The committee reports will be taken up the second day, and on the third day the members will visit the plants of the Parkesburg Iron & Steel Company and the Lukens Iron & Steel Company. Two addresses will be made and the unfinished business taken up on the last day, when the annual dinner will also be held.

*Niagara Frontier Car Men's Association.*—The Niagara Frontier Car Men's Association was organized at Buffalo, N. Y., March 26, 1914. The objects of the association are to bring together those interested in car department matters for the purpose of exchanging ideas and discussing questions of interest, with the object of facilitating the movement of cars and educating the car man to a keener knowledge of economy in maintenance of equipment. Meetings will be held once a month at Buffalo, N. Y., at which time papers of interest and benefit to the members will be presented. The first meeting will be held May 18 at Conley's Hall, 646-662 Main street, Buffalo, when G. J. Charlton, general foreman car department Delaware, Lackawanna & Western, will present a paper on the "Proper Method of Packing and Lubricating Journals." The officers of the association are as follows: President, W. H. Sitterly, general car inspector Pennsylvania Railroad; first vice-president, W. B. Shone, special inspector New York Central & Hudson River; second vice-president, John McCormick, foreman Lehigh Valley; treasurer, G. J. Charlton, general foreman car department Delaware, Lackawanna & Western; secretary, E. Frankenberger, Pennsylvania Railroad, 623 Brisbane building, Buffalo, N. Y.

The following list gives names of secretaries, dates of next or regular meetings, and places of meeting of mechanical associations.

- AIR BRAKE ASSOCIATION.—F. M. Nellis, 53 State St., Boston, Mass. Convention, May 5-8, 1914, Detroit, Mich.
- AMERICAN RAILWAY MASTER MECHANICS' ASSOC.—J. W. Taylor, Karpen building, Chicago. Convention, June 15-17, 1914, Atlantic City, N. J.
- AMERICAN RAILWAY TOOL FOREMEN'S ASSOCIATION.—A. R. Davis, Central of Georgia, Macon, Ga. Convention, July 20-22, 1914, Hotel Sherman, Chicago.
- AMERICAN SOCIETY FOR TESTING MATERIALS.—Prof. E. Marburg, University of Pennsylvania, Philadelphia, Pa. Convention, June 30-July 4, Hotel Traymore, Atlantic City, N. J.
- AMERICAN SOCIETY OF MECHANICAL ENGINEERS.—Calvin W. Rice, 29 W. Thirty-ninth St., New York. Convention, June 16-19, St. Paul-Minneapolis, Minn.
- CAR FOREMEN'S ASSOCIATION OF CHICAGO.—Aaron Kline, 841 North Fifthieth Court, Chicago; 2d Monday in month, except July and August, Lytton building, Chicago.
- CHIEF INTERCHANGE CAR INSPECTORS' AND CAR FOREMEN'S ASSOCIATION.—S. Skidmore, 946 Richmond street, Cincinnati, Ohio. Convention, August 25-27, 1914, Cincinnati, Ohio.
- INTERNATIONAL RAILWAY FUEL ASSOCIATION.—C. G. Hall, 922 McCormick building, Chicago. Convention, May 18-22, 1914, Chicago.
- INTERNATIONAL RAILWAY GENERAL FOREMEN'S ASSOCIATION.—William Hall, 829 W. Broadway, Winona, Minn. Convention, July 14-17, 1914, Hotel Sherman, Chicago.
- INTERNATIONAL RAILROAD MASTER BLACKSMITHS' ASSOCIATION.—A. L. Woodworth, Lima, Ohio. Convention, August 18-20, 1914, Milwaukee, Wis.
- MASTER BOILER MAKERS' ASSOCIATION.—HATTY D. VOUGHT, 95 Liberty St., New York. Convention, May 25-28, 1914, Hotel Walton, Philadelphia, Pa.
- MASTER CAR BUILDERS' ASSOCIATION.—J. W. Taylor, Karpen building, Chicago. Convention, June 10-12, 1914, Atlantic City, N. J.
- MASTER CAR AND LOCOMOTIVE PAINTERS' ASSOC. OF U. S. AND CANADA.—A. P. Dane, B. & M., Reading, Mass. Convention, September 8-11, 1914, Nashville, Tenn.
- NIAGARA FRONTIER CAR MEN'S ASSOCIATION.—E. Frankenberger, 623 Brisbane building, Buffalo, N. Y. Meetings monthly; next meeting, May 18, 1914, 646 Main St., Buffalo.
- RAILWAY STOREKEEPERS' ASSOCIATION.—J. P. Murphy, Box C, Collinwood, Ohio. Convention, May 18-20, 1914, Hotel Raleigh, Washington, D. C.
- TRAVELING ENGINEERS' ASSOCIATION.—W. O. Thompson, N. Y. C. & H. R., East Buffalo, N. Y. Convention, August, 1914, Chicago, Ill.

RAILROAD CLUB MEETINGS

Club	Next Meeting	Title of Paper	Author	Secretary	Address
Canadian .....	May 12	Annual Meeting, Election of Officers.....	W. G. Howard and W. F. Goltra.....	Jas. Powell .....	Room 13, Windsor Hotel, Montreal.
Central .....	May 8	Forestry and Forest Fire Fighting.....	W. F. Goltra.....	H. D. Vought...	95 Liberty St., New York.
New England....	May 12	Steam Turbines .....	Elmer Smith .....	Wm. Cade, Jr....	683 Atlantic Ave., Boston, Mass.
New York.....	May 15	Bureau Inspection by Railroads.....	Wm. F. Zimmerman.....	H. D. Vought...	95 Liberty St., New York.
Pittsburgh .....	May 22	Ill Effects of Boiler Feed Waters.....	W. A. Converse.....	J. B. Anderson...	207 Penn. Station, Pittsburgh, Pa.
Richmond .....	.....	.....	.....	F. O. Robinson...	C. & O. Ry., Richmond, Va.
St. Louis .....	May 8	The Railroads and the People.....	Pat Nelson .....	B. W. Frauenthal	Union Station, St. Louis, Mo.
Southern & S'w'r .....	.....	.....	.....	A. J. Merrill...	218 Grant Bldg., Atlanta, Ga.
Western .....	May 19	Annual Meeting .....	.....	Jos. W. Taylor...	1112 Karpen Bldg., Chicago, Ill.

## PERSONALS

*It is our desire to make these columns cover as completely as possible all the changes that take place in the mechanical departments of the railways of this country, and we shall greatly appreciate any assistance that our readers may give us in helping to bring this about.*

### GENERAL

WILBUR D. ARTER has been appointed supervisor of apprentices of the New York Central & Hudson River, with headquarters at New York, succeeding Henry Gardner, resigned.

E. G. CROMWELL has been appointed motive power inspector of the Baltimore & Ohio, with headquarters at Baltimore, Md.

C. A. GILL has been appointed assistant district superintendent of motive power of the Baltimore & Ohio, at Baltimore, Md., succeeding J. W. G. Brewer, resigned.

W. H. MALONE has been appointed assistant superintendent of locomotive performance of the St. Louis & San Francisco, with headquarters at Springfield, Mo.

D. J. MULLEN, assistant to the superintendent of motive power of the Cleveland, Cincinnati, Chicago & St. Louis, has been appointed superintendent of motive power, with headquarters at Indianapolis, Ind., succeeding S. K. Dickerson, resigned.

F. K. MURPHY has been appointed assistant to the superintendent of motive power of the Cleveland, Cincinnati, Chicago & St. Louis, with headquarters at Indianapolis, Ind., succeeding D. J. Mullen, promoted.

W. E. RICKETSON, who has been appointed mechanical engineer of the Cleveland, Cincinnati, Chicago & St. Louis, with headquarters at Beech Grove, Ind., as announced in the April issue, was graduated from Cornell University in 1907, with the degree of M. E. He began railway work in 1903 with the Delaware & Hudson Company, for which company he worked during his summer vacations while attending college. From 1907 to 1910 he was special apprentice with the Lake Shore & Michigan Southern, and the following two years successively was roundhouse foreman of the Lake Erie, Alliance & Wheeling at Alliance, Ohio, and the Lake Shore & Michigan Southern at Ashtabula. He was then general foreman of the latter road at Youngstown, Ohio, until September, 1913, when he was appointed assistant mechanical engineer of the Cleveland, Cincinnati, Chicago & St. Louis, which position he held at the time of his promotion to mechanical engineer.

P. O. WOOD has been appointed superintendent of locomotive performance of the St. Louis & San Francisco, with headquarters at Springfield, Mo., succeeding Robt. Collett, resigned.

### MASTER MECHANICS AND ROAD FOREMEN OF ENGINES

MARK BAER has been appointed master mechanic of the Colorado, Kansas & Oklahoma, with headquarters at Scott City, Kan.

CHARLES F. BARNHILL, whose appointment as division master mechanic of the Gulf, Colorado & Santa Fe, with headquarters at Silsbee, Tex., was announced in the April issue, was born December 26, 1872, at McArthur, Ohio. He was educated in the common schools, and began railway work in October, 1886, with the Ohio Southern, as a machinist apprentice at Springfield, Ohio. After completing his apprenticeship in November, 1891, he was employed as machinist at the Lagonda shop at Springfield for seven months, when he went to the Chesapeake & Ohio as machinist at Clifton Forge, Va. From February, 1893, to November, 1898, he was successively machine foreman, erecting foreman and general foreman at Clifton Forge, and the following two years was erecting foreman at Hunting-

ton, W. Va. In November, 1900, he went to the Columbus, Shawnee & Hocking as machinist at Columbus, Ohio, and from July, 1901, to December, 1902, was machine and erecting foreman at that place. Mr. Barnhill then became connected with the Gulf, Colorado & Santa Fe as erecting foreman at Cleburne, Tex. In May, 1904, he was made roundhouse foreman at that point, and in March, 1907, was promoted to division foreman at Gainesville, Tex., which position he held at the time of his appointment as master mechanic of the Beaumont division on March 1, as above noted.

H. BOOTH has been appointed road foreman of engines of the Delaware & Hudson Company, with headquarters at Carbondale, Pa.

J. COOLS has been appointed supervisor of locomotive operation of the Erie Railroad, with headquarters at Jersey City, N. J.

J. CUNNEEN has been appointed supervisor of locomotive operation of the Erie Railroad, with headquarters at Jersey City, N. J.

J. W. HIGHLEYMAN has been appointed assistant master mechanic of the Union Pacific, with headquarters at Cheyenne, Wyo.

M. S. MONTGOMERY has been appointed road foreman of engines of the Northern Pacific, with headquarters at Duluth, Minn.

JAMES ROBERTS has been appointed master mechanic of the Union Pacific, with headquarters at Kansas City, Mo.

W. SINNOTT has been appointed master mechanic of the Baltimore & Ohio, with headquarters at East Side, Philadelphia, Pa.

M. K. TATE has been appointed master mechanic of the Cleveland, Cincinnati, Chicago & St. Louis at Beech Grove, Ind.

### CAR DEPARTMENT

P. W. HELWIG, general car foreman of the Minneapolis & St. Louis, at Minneapolis, Minn., has been appointed master car builder of the Chicago & Alton, with headquarters at Bloomington, Ill., succeeding T. M. Ramsdell, resigned.

B. F. LILLY has been appointed general foreman of the car department of the St. Louis, Brownsville & Mexico, with headquarters at Kingsville, Tex., succeeding W. L. Jones, resigned.

H. MACK has been appointed general foreman, car department of the Atchison, Topeka & Santa Fe, at Bakersfield, Cal.

J. O'NEAL has been appointed master car builder of the New Orleans, Mobile & Chicago, with headquarters at Mobile, Ala.

L. C. ORD has been appointed assistant master car builder of the Canadian Pacific, Eastern lines, with office at Montreal, Que., succeeding P. A. Chrysler, assigned to other duties.

A. H. SWEETMAN has been appointed car foreman of the Canadian Northern, at North Battleford, Sask.

### SHOP AND ENGINE HOUSE

F. CLARKE has been appointed locomotive foreman of the Canadian Northern at Calgary, Alta.

CHARLES E. COPP has been appointed foreman of the paint shop of the Billerica, Mass., shops of the Boston & Maine.

B. D. DEHN has been appointed general foreman of the Boston & Maine at Boston, Mass.

E. E. EVANS has been appointed general foreman of shops of the Erie Railroad at Cleveland, Ohio, succeeding J. J. Good, resigned.

J. FIFE has been appointed locomotive foreman of the Great Northern at Casselton, N. D.



CHARLES FITZGERALD has been appointed roundhouse foreman of the Erie Railroad at Cleveland Ohio, succeeding E. E. Evans.

HENRY GARDNER, supervisor of apprentices of the New York Central & Hudson River, has been appointed assistant superintendent of shops of the Baltimore & Ohio at Mt. Clare, Baltimore, Md. Mr. Gardner was born at Salem, Mass., in 1872, and educated in the grammar and high schools and at Massachusetts Institute of Technology in Boston, receiving the degree of mechanical engineer. From 1896 to 1899 he was superintendent of apprentices of the Boston & Maine at Boston, and from 1899 to 1904 he was with the same road at Concord, N. H., as shop draftsman, shop inspector and assistant master mechanic. He was then for one year erecting foreman of the American Locomotive Company at the Pittsburgh Works, and one year with the H. K. Porter Company, Pittsburgh. From 1906 to 1908 he was chief draftsman and apprentice instructor of the Pittsburgh & Lake Erie, and from 1908 to 1912 he was assistant supervisor of apprentices of the New York Central Lines at New York. In 1912 he was appointed supervisor of apprentices of the New York Central & Hudson River, the position he leaves to go with the Baltimore & Ohio as assistant superintendent of shops.

E. C. HANSE has been appointed general foreman of the Atlanta, Birmingham & Atlantic at Talladega, Ala.

M. E. MARTZ has been appointed general foreman of the locomotive department of the Baltimore & Ohio at Somerset, Pa.

EMIL MARX has been appointed general foreman of the Chicago & North Western at Winona, Minn.

C. L. MEGALIS has been appointed general foreman of the Atlanta, Birmingham & Atlantic at Fitzgerald, Ga.

J. K. MILHOLLAND has been appointed general foreman of the locomotive department of the Baltimore & Ohio at Grafton, W. Va.

FRANK REVANA has been appointed erecting shop foreman of the Erie Railroad at Cleveland, Ohio, succeeding T. V. Peterson.

C. W. RHINEHARD has been appointed general foreman of the Atlanta, Birmingham & Atlantic at Brunswick, Ga.

C. W. ROBERTSON has been appointed general foreman of locomotive repairs of the Chicago, Burlington & Quincy at Aurora, Ill.

C. E. TEST has been appointed general foreman of the Chicago Great Western at Council Bluffs, Iowa.

H. THOMPSON has been appointed locomotive foreman of the Canadian Northern Ontario at Parry Sound, Ont., succeeding J. Quinn.

F. S. TORBACK has been appointed general foreman of the locomotive department at the Mount Clare shops of the Baltimore & Ohio at Baltimore, Md.

C. B. VAN BLARCUM has been appointed general foreman of the locomotive department of the Baltimore & Ohio at Columbus, Ohio.

#### PURCHASING AND STOREKEEPING

D. L. DONALDSON has been appointed storekeeper of the Baltimore & Ohio at Parkersburg, W. Va., succeeding J. D. Burke, resigned.

G. W. HAYDEN has been appointed assistant to the chief purchasing agent of the St. Louis & San Francisco, with headquarters at St. Louis, Mo.

W. P. HICKEY has been appointed division storekeeper of the New York Central at Oswego, N. Y., succeeding J. F. Wallace.

H. P. McQUILKIN has been appointed district storekeeper of the Baltimore & Ohio at Cincinnati, Ohio.

F. A. MURPHY has been appointed district storekeeper of the Baltimore & Ohio at Wheeling, W. Va.

E. J. ROTH, assistant general storekeeper of the Chicago, Burlington & Quincy at Chicago, has been appointed supply agent of the Chicago, Indianapolis & Louisville, with headquarters at Lafayette, Ind.

E. W. THORNLEY has been appointed district storekeeper of the Baltimore & Ohio at Glenwood, Pa.

L. H. TUTWILER, traveling storekeeper of the Baltimore & Ohio system, with office at Baltimore, Md., has been appointed district storekeeper, with headquarters at Mount Clare shops, Baltimore, Md.

#### OBITUARY

WILLIAM APPS, formerly master car builder of the Algoma Central & Hudson Bay, died at his home in Toronto, Ont., March 21, aged 67 years. Mr. Aps was also master car builder of the Canadian Pacific from 1895 to 1902.

WILLIAM O'HERIN, assistant to the general manager of the Missouri, Kansas & Texas System, with headquarters at Dallas, Tex., died at the Mercy hospital, Chicago, March 31, aged 69 years. He had been connected with the Missouri, Kansas & Texas for 40 years, beginning as a locomotive fireman. He was later locomotive engineer, and subsequently became master mechanic. He was promoted to superintendent of machinery and equipment in 1897, which position he held until January 1, 1913, when he was made assistant to the general manager.

JOHN R. SKINNER, superintendent of stores of the Delaware & Hudson Company at Oneonta, N. Y., died suddenly on April 6 at his home in that city.

CYRUS WARMAN, for some time past a press agent or publicity adviser of the Grand Trunk at Montreal, died at Chicago April 7 at the age of 68. Mr. Warman was born in Illinois and began railroad work on the Denver & Rio Grande in 1880, working first as a wiper, and later as locomotive fireman and then engineman. At the age of 33, he began to do a little newspaper work in Colorado, and from a small beginning he soon became a popular poet and story writer; and as "Cy Warman" he is widely known in the literary world. He was one of the first, if not the very first, of American railroad men to make a success as a writer of stories of railroad life. He was the first writer who combined the taste requisite to make a pleasing story with the knowledge of railroad work and the candor as an observer necessary to make his delineations true to life.

#### NEW SHOPS

CINCINNATI, NEW ORLEANS & TEXAS PACIFIC.—This road is building with its own forces a passenger coach repair and paint shop at Chattanooga, Tenn. The building will be 300 ft. long, and will be provided with four tracks to hold three cars each.

PENNSYLVANIA LINES.—Plans have been completed for new shop buildings to be located at Indiana Harbor, Ind.

WIRELESS LIGHTHOUSES.—Wireless lighthouses are being established by the French government along the north coast, the first two being situated on islands near the approach to the port of Brest. Two more are planned for the port of Havre. The lighthouses will operate by a system almost exactly like that of ordinary lighthouses, except that, instead of waves of light, wireless waves will give the information to approaching ships. The great advantages of such lighthouses is that fog will not hinder their efficiency.—*The Engineer*.

## SUPPLY TRADE NOTES

The Union Fibre Company, Winona, Minn., has moved its Chicago office from room 1613 Great Northern building to the Railway Exchange building.

R. C. Cole has joined the staff of the pneumatic tool department of the Ingersoll-Rand Company, New York, and has been stationed at the Chicago office.

The Transportation Utilities Company, New York, has acquired the entire business of the General Railway Supply Company, Chicago, effective April 15, 1914.

The engineering and contracting firm of MacArthur Brothers Company, New York, has moved its Chicago office to 1892 Continental and Commercial Bank Building.

The general offices of the Orenstein-Arthur Koppel Company have been moved from Pittsburgh to Koppel, Pa., in order that they may be in closer touch with the plant.

Muir B. Snow has been elected president and general manager of the Detroit Twist Drill Company, Detroit, Mich., to fill the position formerly occupied by his brother, Neil W. Snow, deceased.

Robert Collett, formerly superintendent of locomotive performance of the St. Louis & San Francisco, has been appointed assistant manager of the railway lubricating department of The Pearce Oil Corporation at St. Louis, Mo.

Walter A. Johnson, formerly of Atlanta, Ga., has been appointed pneumatic tool manager at the Pittsburgh branch of the Ingersoll-Rand Company, New York. C. F. Overly, formerly of Pittsburgh, has been appointed pneumatic tool manager at the Cleveland office.

The general offices of the United States Light & Heating Company will be moved on May 20 from 30 Church street, New York, to the company's plant at Niagara Falls, N. Y. This transfer will bring together in one place the administrative, sales, engineering and production departments.

The Titan Storage Battery Company, Newark, N. J., has been established to take over the business of the Baltimore Storage Battery Company, Baltimore, Md. The new company will continue under the same ownership and management as its predecessor. There will be no change in the policy of the latter beyond that of expansion of operations.

The Standard Steel Castings Company, Cleveland, Ohio, has placed in operation a new shop, 80 ft. by 253 ft., and has installed an additional two-ton convertor, thus increasing the capacity of the plant to 25 tons of castings per day. Thomas B. Lavey, who for the past seven years has been superintendent of the Isaac G. Johnson plant at Spuyten Duyvil, N. Y., has been made superintendent.

Walter Bentley has recently been appointed western representative of the Curtain Supply Company, Chicago. He is a son of H. T. Bentley, superintendent of motive power of the Chicago & North Western, and has had a thorough railway training. Beginning in the stores department, he worked his way through various branches of railway work, having served in different departments of the shops and in the roadmaster's, general superintendent's and purchasing agent's offices. The last two years he has represented the Baldwin Locomotive Works and the Standard Steel Works Company.

Frank N. Grigg, whose appointment as sales agent of the Transportation Utilities Company, New York, for the southeastern and southern district of that company, was announced in the April issue, was born in Richmond, Va., August 9, 1876. He entered the employ of the Chesapeake & Ohio in 1892, and spent ten years in the motive power and stores department of that

road. In January, 1903, he became eastern representative of the Adams & Westlake Company, Chicago, and for the past year up to the time of his new appointment he has been district manager of the Standard Heat & Ventilation Company, New York, with office at Washington. Mr. Grigg has his office at room 1201, Virginia Railway & Power building, Richmond. He is also sales agent for the Rostand Manufacturing Company, Milford, Conn.

The announcement is made that the United States Steel Corporation and its subsidiary companies propose to have a comprehensive exhibit of their operations at the Panama-Pacific Exposition in San Francisco in 1915. It will begin with the ore fields, and carry on an educative picture of the operations in ore mining, rail and water transportation, dock operations, coal, coke and pig iron production, steel manufacturing in its various lines, and will also present the processes of manufacturing of many of its subsidiary companies' products, including National pipe; also how it utilizes its by-products and the display of many uses in which its general products are employed, typifying the advancement in the uses of this country's resources. In addition to the material exhibits before mentioned, the corporation intends to exhibit in a comprehensive manner, by moving pictures, its operations throughout all departments showing the ramifications of the processes of the corporation's operations. It is proposed as well to set forth to the world the work which the United States Steel Corporation has done towards the social welfare of its employees and those depending upon them. Also it will exhibit many forms of safety devices that have been conceived by the corporation officials and its employees. In this social welfare department will also be shown the methods employed in the aid and care of the injured.

Frank H. Clark, formerly sales manager of the railroad department of the Watson-Stillman Company, New York, has recently bought the Chambers throttle valve business of that



F. H. Clark

company and established the Chambers Throttle Valve Company with himself as president. Mr. Clark was born in New York on March 8, 1872. He obtained his start in the railway supply business in 1890 when he entered the employ of the Standard Coupler Company, of which his father was president. In 1893 he went south to Atlanta, Ga., to engage in a general railway and mill supply business, and in 1897 in connection therewith opened a machine shop and foundry to which he later added a boiler repair shop. Three years later he sold his business and returned to New York to enter the sales department of the Townsend & Downey Ship Building Company. When this company went out of business in 1903 he became vice-president and treasurer of T. N. Motley & Company, Inc., dealing in railway supplies at New York. He remained with this company about five years and then left to enter the railroad sales department of the Watson-Stillman Company. About three years ago he brought to that company the throttle valve invented by John Chambers, of the Atlantic Coast Line, and has since devoted a very large portion of his time to the development and introduction of that appliance. The office of the new company is at 30 Church street, New York.



## CATALOGS

**POWER HAMMERS.**—Beaudry & Company, Inc., 141 Milk street, Boston, Mass., have recently issued a four page leaflet descriptive of the Beaudry Peerless power hammers. These hammers are either belt or motor driven and are made in seven sizes.

**LOCOMOTIVE CRANES.**—Bulletin No. 30 from the McMyler Interstate Company, Cleveland, Ohio, is descriptive of that company's type J standard gage locomotive crane. Illustrations are included showing the cranes in use in various capacities.

**DRILLING STANDS.**—Bulletin E-31 of March 1, 1914, issued by the Chicago Pneumatic Tool Company, Fisher building, Chicago, is devoted to the Duntley electric sensitive drilling stands. Information is also given concerning electric drills to fit these stands.

**METAL MOULDINGS AND SHAPES.**—This is the subject of a catalog just issued by the Dahlstrom Metallic Door Company, Jamestown, N. Y., manufacturers of cold drawn metal mouldings. The catalog is very complete and shows a large variety of shapes for metal moulding.

**YOST DRAFT GEAR.**—Pamphlet No. 18, issued by the Hart-Otis Car Company, Ltd., Montreal, Que., describes the Yost draft gear. This is a lever friction draft gear of high capacity and has been in experimental service for several years. It is now in use on a large number of cars in severe service.

**PUNCHES AND SHEARS.**—Catalog 12 from The Ironton Punch & Shear Company, Ironton, Ohio, illustrates and describes the various machines made by that company, including vertical punches and shears, horizontal punches, universal shears, straightening rolls, bending rolls, multiple punches, gate shears, steam hammers and other tools.

**BALL BEARINGS IN AXLE GENERATORS.**—Bulletin No. 12 of the S. K. F. Ball Bearing Company, 50 Church street, New York, is a 15 page booklet dealing with the use of ball bearings in the axle generators of railway electric lighting equipment. The booklet is well illustrated and contains on the last page, a list of the railways using this type of bearing in axle generators.

**STEEL BOILER TUBES.**—The National Tube Company, Pittsburgh, Pa., has issued a circular entitled About Steel Boiler Tubes, which is based on the report of the International Boiler-makers' Association committee on the subject of steel versus iron tubes. The economy claimed for the National steel tube is presented in this circular in the form of a problem in arithmetic.

**FOSTER LOCOMOTIVE SUPERHEATER.**—The Power Specialty Company, 111 Broadway, New York, is issuing a catalog devoted to the Foster locomotive superheater. The first installation of this superheater was made on the Pennsylvania Railroad over two years ago. The catalog includes drawings showing the application of the superheater as well as drawings of a number of detail parts.

**SAFETY FIRST IN EMERY WHEEL WORK.**—The American Emery Wheel Works, Providence, R. I., has recently issued a chart on how to prevent grinding wheel accidents. This chart is so arranged that it may conveniently be hung on a wall. A red disc with the words "Safety First" in white appears in the center. Copies of the chart will be furnished to users of grinding wheels on application.

**FLEXIBLE JOINTS.**—The Moran Flexible Steam Joint Company, Inc., Louisville, Ky., has issued a catalog showing the various types of flexible connectors for pipe which are manufactured by that company. Illustrations are included showing these joints in use on steam lines in engine houses, as well as in the flexible connections between locomotives and tenders. Patents have been granted on an application to locomotive steam pipes.

**THE PITOT TUBE AND FAN TESTING.**—This is the subject of bulletin No. 35, Series 1, of January, 1914, issued by the American Blower Company, Detroit, Mich. The bulletin contains 32 pages and is issued solely in the interest of standardizing procedure so that fan ratings can be specified in a manner understood by all who have to deal with them. The American Blower Company does not manufacture nor sell the instruments described in the pamphlet.

**STEEL PIPE.**—In some way the Bulletin No. 11B, issued by the National Tube Company, Pittsburgh, Pa., and commented on in this column last month, was headed "Iron Pipe." There was no excuse for this error, as any one who is at all familiar with the products manufactured by the National Tube Company must realize that it has to do only with steel products. In this connection that company has just issued a folder under the title of "Thought It Was Steel—But It Wasn't," which indicates clearly the nature of its product.

**GERMAN LOCOMOTIVES.**—The February, 1914, number of the Hanomag Journal gives a description of the 7000th locomotive turned out by the Hannoversche Maschinenbau-Actien-Gesellschaft, Hanover, Germany. This locomotive was completed January 30, 1914, and is a ten-wheel freight engine, with superheater, for the Prussian State Railways. The Journal also includes illustrations of the first locomotive turned out at these works and a historical sketch dealing with the most important locomotives from the first to the 7000th.

**SILENT CHAIN DRIVE.**—Book No. 125 issued by the Link-Belt Company, Chicago, contains a great deal of valuable information concerning the application of that company's link-belt silent chain to various kinds of machinery. The book contains 112 pages, and is handsomely gotten up and well illustrated. Among other data it includes a number of tables giving the horsepower transmitted by link-belt chains of various pitches and widths at different speeds. It is possible with this book to select the size of chain and wheel most suitable for any work under consideration.

**FORGES, BLOWERS, EXHAUST FANS, ETC.**—General catalog No. 179 has been issued by the Buffalo Forge Company, Buffalo, N. Y. It is 5 in. by 7½ in. in size, and contains 304 pages. Among the various lines of equipment and tools which are illustrated and described in more or less detail are forges; blowers; exhaust fans; disk fans; drills; punches; shears; bending machines; tire setters; combination woodworking machines; steam engines and turbines; fan system apparatus for heating, ventilating, drying and mechanical draft; air washers; humidifiers and dehumidifiers.

**AXLE LIGHT.**—Bulletin No. 11 from the Consolidated Railway Electric Lighting & Equipment Co., Hanover Bank building, New York, tells of the development of the Consolidated axle light equipment, and in an attractive manner describes fully the various details of the apparatus and the principal advantages which are claimed for it. While no radical changes have been made in the equipment, a number of important improvements have been made in the details. The dynamo has cast handhold covers instead of sheet iron covers, the pole changer has been strengthened and Timken roller bearings have been added.

**STREET LOCOMOTIVE STOKER.**—Catalog 14, from the Locomotive Stoker Company, Schenectady, N. Y., discusses briefly the advantages of the Street locomotive stoker, and presents general views and important dimensions of a number of locomotives equipped with such stokers on the Baltimore & Ohio, Norfolk & Western, Chesapeake & Ohio, Hocking Valley, Virginian, New York Central Lines, Chicago, Burlington & Quincy, and the Buffalo, Rochester & Pittsburgh. Then follow comments on the effect of the mechanical stoker on tonnage, steam pressure, capacity, speed, train movements, cleaning fires, safety, reliability, labor and the fireman.

# Railway Age Gazette

MECHANICAL EDITION

## INCLUDING THE AMERICAN ENGINEER

PUBLISHED ON THE FIRST THURSDAY OF EVERY MONTH BY THE  
SIMMONS-BOARDMAN PUBLISHING COMPANY,  
WOOLWORTH BUILDING, NEW YORK, N. Y.

CHICAGO: Transportation Bldg. CLEVELAND: Citizen's Bldg.  
LONDON: Queen Anne's Chambers, Westminster.

EDWARD A. SIMMONS, *President* L. B. SHERMAN, *Vice-President*  
HENRY LEE, *Secretary*  
The address of the company is the address of the officers.

ROY V. WRIGHT, *Editor*  
R. E. THAYER, *Associate Editor* C. P. PECK, *Associate Editor*  
A. C. LOUDON, *Associate Editor* GEORGE L. FOWLER, *Associate Editor*

Subscriptions, including the eight daily editions of the *Railway Age Gazette* published in June in connection with the annual conventions of the Master Car Builders' and American Railway Master Mechanics' Associations, payable in advance and postage free:

United States, Canada and Mexico.....	\$2.00 a year
Foreign Countries (excepting daily editions)....	3.00 a year
Single Copy .....	20 cents

Entered at the Post Office at New York, N. Y., as mail matter of the second class.

WE GUARANTEE, that of this issue 4,400 copies were printed; that of these 4,400 copies, 3,672 were mailed to regular paid subscribers, 150 were provided for counter and news' companies sales, 259 were mailed to advertisers, exchanges and correspondents, and 319 were provided for samples and office use; that the total copies printed this year to date were 26,000, an average of 4,334 copies a month.

VOLUME 88

JUNE, 1914

NUMBER 6

### CONTENTS

**EDITORIALS:**

The Draft Gear Competition.....	277
Competition on Engine House Work.....	277
Ash Pan Air Openings.....	277
Economy in Tools.....	277
Studying the Distribution of Power.....	278
The Fuel Association.....	278
Maintenance of Draft Gear.....	278
General Officers and the Drawing Office.....	279

**COMMUNICATIONS:**

Reducing the Weight of Boilers.....	280
Why College Men Leave Railway Work.....	280
Eliminate Your Metallic Packing Troubles.....	280
Wiring for Electric Headlights.....	281
Step for Locomotive Running Boards.....	281
Turning Driving Wheel Tires.....	281
Questions for Car Designers.....	282
Watering Rails to Prevent Slipping.....	282

**GENERAL:**

Railway Fuel Association Convention.....	283
Flange Lubricators.....	293
Railway Storekeepers' Association.....	294
Performance of French Pacific Type Locomotives.....	298

**CAR DEPARTMENT:**

Hot Boxes.....	299
Air Brake Association Convention.....	301
Freight Car Design and Construction.....	306
Dairy Refrigerator Car.....	308
Reflector for Observation Car Windows.....	310

**SHOP PRACTICE:**

Plant for Repairing Boiler Tubes.....	311
Vacuum Lifting Device.....	312
Master Boiler Makers' Convention.....	313
Drilling the Smokebox Flanges of Locomotive Cylinders.....	319
Apprentice Material.....	319
Jig for Drilling Crosshead Shoes.....	320
Electric Welding at the Angus Shops of the Canadian Pacific.....	321
Grinding Exhaust Nozzles.....	322

**NEW DEVICES:**

Planer for Heavy Work.....	323
Triplex Hydraulic Pump.....	323
Hancock Coal Sprinkler.....	325
Oxy-Acetylene Welding Applied to Manufacturing.....	325
Horizontal Drilling Machine.....	326
Strainer and Drain Valve.....	326
Interesting Adaptation of Electric Hand Drill.....	327
Heavy Service Shaper.....	327
Cast Steel Bumper with Friction Draft and Buffing Gear.....	328
Portable Radial Swing Grinder.....	329
Ball Bearings on Turntables.....	329
Grinding Machine of the Open Side Planer Type.....	330
Long Distance Gasolene and Oil Pump.....	330
Adjustable Pliers.....	331
High Pressure Volumetric Air Meter.....	331
Yost Draft Gear.....	332

**NEWS DEPARTMENT:**

Meetings and Conventions.....	334
Personals.....	335
Supply Trade Notes.....	337
Catalogs.....	338

**The Draft Gear Competition**

A large number of contributions were received in the draft gear competition which closed on May 15. Because of the number it has been impossible for the judges to thoroughly examine them and come to any decision as to the prize winner in time for publication in this issue. It is expected that all of the papers will be examined within the next two or three weeks and that the prize article will be published in our July number. We wish to take this opportunity of thanking those of our friends who co-operated with us so heartily and effectively in helping to make the competition a success.

**Competition on Engine House Work**

Remember the competition on engine house work which was announced in the May issue. A prize of \$50 is offered for the best article on this subject received before July 15, 1914. The judges will base their decision on the practical utility of the suggestions made or the practices which are described, and space rates will be paid for articles which are accepted for publication but do not win the prize. There is no restriction placed on the subject chosen, but it must be along the lines of the handling of running repairs to locomotives in round-houses. A number of suggestions were made in the original announcement, and among these was the subject of the organization of forces. The perfecting of an efficient organization in an engine house is a difficult matter, and any light that can be thrown on a means of accomplishing this will be greatly appreciated by many engine house foremen and others. There are foremen in this country handling large engine houses successfully who should be able to write a very interesting and instructive article on the organization of an engine house staff.

**Ash Pan Air Openings**

The principal topic of discussion during the first day of the Fuel Convention was ash pan air openings. The first principle of fuel economy is to consume every particle of fuel as thoroughly as possible. To do this oxygen must be present, and enough of it to combine with the gases emitted from the fuel. In other words, air must be present in the fire-box and in the fuel bed. Professor Parr pointed out in his chemical treatise on clinkering and honey-combing, that an insufficient air supply materially aided the formation of clinkers, and that on account of this the ash was not carried to its infusible state. The discussion that followed substantiated his claims and many instances were mentioned whereby honey-combing was eliminated by increasing the ash pan air openings.

Mr. Hatch in his paper on ash pan air openings, showed the advantages to be gained by having these openings large enough, giving instances where they had been found materially deficient. This subject is worthy the serious consideration of all mechanical officers and any improvements made will show returns in increased fuel efficiency.

**Economy in Tools**

An interesting discussion at the convention of the Railway Storekeepers' Association, held in Washington, D. C., May 18-20, centered on the question of receiving salvage when issuing tools. On many roads the practice is consistently followed out of insisting on a broken hammer or oil can being received when a new one is issued unless there are very good reasons for issuing the new tool without any return. In such cases an order signed by some one in authority must be presented before the new material is issued. It is difficult to understand why some practice of this nature is not more generally carried out. If it were, it is quite safe to say that the number of shovels and oil cans that are stowed away on most locomotives for emergencies would be considerably reduced. A case in point is that of a locomotive which had six scoop shovels in good condition hidden away in various places. If the fireman



of this engine had been compelled to turn in a broken or damaged shovel every time he got a new one it is improbable that this condition would have existed. There are a great many men who seem to have a mania for collecting as many tools of one kind as they can possibly lay their hands on, and another means of preventing such accumulation is that of checking up the equipment on locomotives periodically. Such a checking should not be made merely with the idea of removing all excess tools but also to see that each locomotive has a proper equipment of tools. There are plenty of locomotives that have no tools of one kind, while others have several of the same kind, and if a proper distribution were made it would not only place all of the enginemen in better position in case of trouble while on the road, but by distributing the tools where they are needed, would avoid the necessity of tools being drawn from the store department to complete the locomotive equipment.

#### Studying the Distribution of Power

In his opening address before the International Railway Fuel Association at the convention held in Chicago, May 18 to 21, President Collett touched briefly on the careful and studied distribution of locomotives to different parts of a railway to secure the best results. The Frisco, with which Mr. Collett was until recently connected, has had remarkable results from such methods of power distribution, developed largely under his direction.

It is difficult to understand why more roads have not gone more deeply into this question. For example, there are locomotives on almost any railway traversing a bad water district, which give much less trouble than others when using this water. Would it not, therefore, be the logical move to assign as many locomotives of that class as were available to the bad water district, transferring the others to districts with a better quality of water? We have in mind a case in which several locomotives of a class that caused much trouble by foaming, were operated on a district where the water was of a nature that greatly aggravated this trouble. It was impossible to work them more than one round trip without a washout, or at least a change of water. There was another class of locomotives on the road, noted because of the absence of trouble from foaming. These engines were slightly less powerful than the others, and for that reason the operating officers refused to assign them to that district, regardless of the fact that the larger engines could not at any time be worked to their full capacity because of foaming, and in no instance got over the road with full tonnage without having to double several times.

Another practice which does not make for economy is the use on a locomotive of coal radically different from that for which the engine is drafted, without making any alterations in the grates or front end arrangement. The usual result in such cases is a repetition in the roundhouse work book of the report "engine not steaming," until the foreman, employing a method of "cut and try," gets the nozzle tip small enough by bridging or bushing, so that a sufficiently violent draft is created to make the engine steam in spite of the nature of the coal. In one instance of this kind, the road foreman of engines had the tip reduced from  $4\frac{1}{2}$  in. to  $3\frac{5}{8}$  in., with the result that the engine steamed; but the effect on the hauling capacity can be readily imagined and needs no enlarging upon. Either the locomotive should not have been assigned to a division where it was necessary to use coal of such quality, or it should have been carefully redrafted and different grates installed, if necessary, to insure the obtaining of maximum economy.

There may be, and probably are, locomotives that will do reasonably good work under considerably varying conditions. Some roads have standardized designs that are used with slight changes over an entire system; but it must be remembered that these engines were designed only after a careful study of

the conditions over the entire road, and that these conditions were given due consideration in the designing. Even then it is seldom possible to produce an engine that will satisfactorily meet the requirements of every division without some alterations being made.

It should not be expected that all locomotives will work equally well under all conditions and by bearing this carefully in mind in making power assignments, much more satisfactory results may be obtained.

#### The Fuel Association

The sixth annual convention of the International Railway Fuel Association, held in Chicago last month, was one of the best conventions the association has held. This organization is peculiar in that it aims to interest everybody having anything to do with fuel on railroads. It therefore includes in its membership coal mine operators, fuel experts, railway fuel agents, fuel inspectors and those men whose duties have to do with the consumption of fuel. Naturally with such a membership, the fuel situation is viewed from a number of different angles, although there are some problems that are common to all. The task, therefore, of choosing subjects that will interest and be of value to the entire membership is difficult, and the association is to be congratulated on the success with which it met this condition. The subjects taken as a whole, were broad enough to be of interest to all of the members, and at the same time specific enough to give detail information to those who desired it.

Some members believed that this year's program contained too many papers to permit of thorough discussion within the time allowed, and it was suggested that a lesser number be presented next year. There is no question but that this is a good plan. Other associations have followed this practice with very good results. It gives the members an opportunity to thoroughly digest all of the subjects to be presented before they reach the convention and to formulate ideas to be offered in the discussion of the papers. The discussion of papers presented at a meeting of this kind is of great importance, and, in some cases, more important than the paper itself; so that everybody should be given an opportunity to add what they can from their own experience. Further, they should come to the convention fully prepared to offer something of value on the subjects under discussion. No member should be guilty of saying "I have nothing to say on the subject; I came to listen," when requested by the chair to make some remarks. Such persons might as well say, "I came to hear what other roads are doing in this respect, but what we are doing we will keep to ourselves." A broad, intelligent discussion is the life of the association and every member should do what he can to increase its value. As a member he owes it to the association.

#### Maintenance of Draft Gear

A master car builder, who has given much time and observation to the study of the draft gear problem, in commenting on our competition which closed on May 15, suggested that far too little attention is given to the proper upkeep and maintenance of that part of the equipment. One of the most important functions of the draft gear is to protect the car from damage in transmitting and absorbing the pulling and buffing stresses. It is therefore of prime importance that it be kept in good condition and that such repairs or replacements as are necessary from time to time be made promptly. The draft gear, unlike most of the other important parts of the equipment, is located where it is difficult to inspect it, and especially to observe its action under working conditions. Because it is out of sight, little thought is given to it unless its condition becomes so bad that serious damage is done to other parts of the car. Then it is immediately condemned because of its failure, although such failure might easily have been prevented if the gear had been in-

spected more regularly and more carefully, and a few slight adjustments had been made to compensate for the wear and deterioration.

When wheels are applied to a freight car it is with the expectation that they will have to be renewed in a period of five years, or less. Different parts of the air brake are periodically inspected, and cleaned and repaired at a heavy expense. And yet in spite of the severe demands made upon it the draft gear is expected to do duty indefinitely without wear or breakage, and if it fails it is severely condemned. The master car builder referred to above, after making a careful check, has come to the conclusion that the draft gear should be overhauled after it has been in service about five years. If done at this time the conditions are such that the expense will be less than if a longer period is allowed to intervene and greater insurance will be afforded the car and its lading. If thoroughly overhauled and readjusted it is expected that the gear will continue in service for another four or five years without any very great amount of attention.

#### General Officers and the Drawing Office

It will be generally admitted that the average railroad drawing office takes considerable time in turning out work. This may be due to lack of organization; and in some cases it is undoubtedly due to this cause, in part, but all railroad drawing offices are not poorly organized, and even where the organization is not what it might be, there are other causes contributing to slow accomplishment of results. There may be, and probably are in many cases, more than two such causes, but there are two which will probably appeal to anyone familiar with drawing office methods as being among the foremost—the haphazard way in which higher officers demand information from the mechanical engineer, and the switching from one job to another, which is necessary in order to furnish the information.

When information is required by railway commissions, or for use in answering questions at investigations, the entire drawing office staff, or a great part of it, as a rule, has to be concentrated on the work and other matters set aside until it is completed. It is conceded that such conditions will seriously disorganize the routine work, and unfortunately such conditions, due to the activity of the various commissions, have very often been the rule rather than the exception. But aside from such conditions, which at the worst are but temporary, general officers frequently use little or no judgment or consideration in making demands on the drawing office. It requires but little search to find examples of important work being entirely dropped for several days to prepare information which has been requested "at once" by a superintendent of motive power or a vice-president, and which, after it has been furnished, lies unused for weeks or months. It may be urged that the officer concerned believed when he made the request that it was urgent. Probably he did; there are times when such conditions are bound to crop up; but they should not be allowed to do so every day, as they do on some roads. If some of our higher officers would endeavor to instill into themselves and their own office staffs some of the ideas as to efficiency which they are constantly urging on their subordinate officers, conditions in this respect would be much improved.

The second cause for waste of time is largely a product of the first. Taking draftsmen away from work on which they have their minds concentrated means, aside from the time taken in accomplishing the other work, a waste in getting settled down again when it is finished; and when the second job, as is sometimes the case, hangs fire, a man may have several jobs on his hands at once and be continually shifting from one to another, a condition which is productive of much lost time. This can, however, be avoided to a considerable extent by keeping a portion of the staff on the larger jobs and assigning the less im-

portant work to others who are kept free from heavy assignments purposely for handling short jobs and preparing information for hurried demands. This also provides a good means of training men for later assignment to the more advanced designing and testing work, when vacancies occur.

#### NEW BOOKS

*Hand Book of United States Safety Appliance Standards for Freight Cars.* Bound in paper. 32 pages. Size 4 in. by 6 in. Published by J. D. MacAlpine, Cleveland, Ohio. Price, 10 cents per copy; 75 cents per dozen copies; \$5 per hundred copies.

This pamphlet is a copy of the safety appliance standards issued by the Interstate Commerce Commission, and was compiled with the idea of presenting these standards in a convenient form for car inspectors. The book is well indexed and contains plates showing the application of various standards.

*How to Build Up Furnace Efficiency.* By Joseph W. Hays, combustion engineer. 125 pages. 4¾ in. by 7¼ in. Illustrated. Published by Joseph W. Hays, Rogers Park, Chicago, Ill. Price \$1.

This is intended as a handbook of fuel economy and is the seventh edition published. The book is written in a breezy manner and anecdotes are frequently used for the purpose of illustration. The chapters deal with such subjects as Why and How Fuel Is Wasted, How to Determine Fuel Waste, How to Stop It and How to Keep It Stopped.

*Structural Design.* By Horace R. Thayer, assistant professor of structural design, Carnegie Institute of Technology, Pittsburgh, Pa. 228 pages. 6 in. by 9 in. Illustrated. Published by D. Van Nostrand Company, 25 Park Place, New York. Price \$2.

This is a second edition, revised, of volume one and considers the elements of structural design. The author has endeavored to develop a book which logically connects mechanics and stresses on the one hand and structural design on the other. This gap in the past has usually been filled by lectures, notes and personal explanations on the part of the teacher. Volume two, which is now in preparation, will apply these principles to the design of simple structures such as I beams, spans and plate girder bridges. This will be followed by a third volume on such advanced structures as cantilevers, movable bridges, suspension spans and arches. The whole series will be uniform in style and treatment. It is intended throughout to combine theoretical and practical considerations, giving each its due emphasis, at the same time preserving an order and arrangement which render it a desirable text.

*The Fuels Used in Texas.* By William B. Phillips and S. H. Worrell. 269 pages. 6 in. by 9 in. Illustrated. Bound in paper. Published by the University of Texas, Austin, Texas.

This is bulletin No. 307, issued by the University of Texas. The reason for offering the publication is based on the fact that while Texas has large supplies of good and cheap fuel it is not utilized to the best advantage. The production of coal, lignite, natural gas and petroleum does not nearly keep pace with current demands nor promise well for the future. The workable area of coal in the state is 8,200 square miles, with a possible addition of 5,300 square miles. The workable lignite area is 50,000 square miles, with a possible addition of 10,000 square miles. A special feature of the coal industry in Texas is that by far the greater proportion of the product is used for railroad purposes, only a small proportion going into domestic use. The book has a number of excellent half-tone illustrations and contains a large number of tables giving the composition of the various Texas coals and lignites. Considerable space is also devoted to the briquetting of Texas lignite, as well as its distillation for the recovery of by-products.



## COMMUNICATIONS

### REDUCING THE WEIGHT OF BOILERS

Boston, Mass., February 9, 1914.

TO THE EDITOR:

No American horizontal return tubular boiler built with butt joints has exploded, I believe, in the joint, but two, to my knowledge, have cracked at the edges of the joints sufficiently to cause leakage. The pressure was immediately reduced and explosions thus prevented. I shall not be surprised to hear of more cases, and there may be a few explosions. The reason for the trouble with butt joints is that, as usually designed, they possess a feature which causes bending of the plate with changes in pressure, as in the case of a lap joint, but to a smaller extent. They are so designed that they are not equally strong on both sides of the plate, and the joint bends as the pressure increases, and returns as it decreases. Some years ago I designed several wide joints and tested them to destruction on the large machine at the Watertown Arsenal. They were so wide that it required

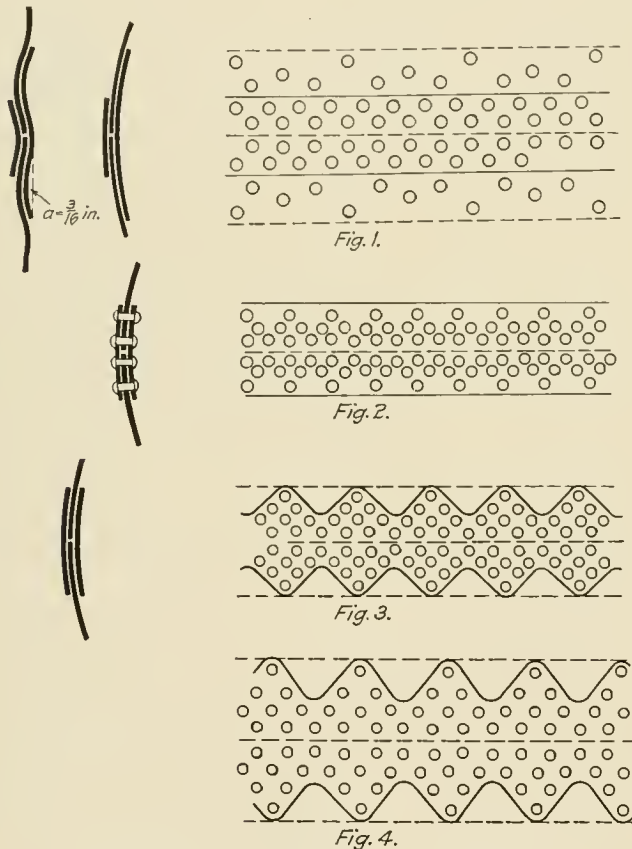

Recommended Arrangement of Riveted Joints

from 350,000 lb. to 450,000 lb. to break them. While under strain they always took the form shown in Fig. 1 and the distance  $c$  was about  $3/16$  in. when they broke. I did not appreciate the significance of this behavior at the time, and not until the cracking of the plates in the two butt joint boilers referred to did this dawn upon me. The one-sided feature of the joint caused the bending, the bending caused the cracks, and the cracks would have caused explosions if they had not been detected by the escaping steam.

Since these cracks occurred I have always required the butt straps of boilers on the opposite sides of the plates to be of the same width and the rivets in double shear. Furthermore, I have made the straps as narrow as possible in order to have the rows of rivets as near together as practicable so that the inside strap, which is not caulked, would have small opportunity to straighten

out, due to the curvature of the shell, between rows of rivets. I have always made inside straps very thick to diminish this action.

Figs. 2 and 3 show such joints as I advocate, Fig. 3 showing the better design. The latter joint can be made with an efficiency of 92 per cent. or more. The joint in Fig. 1 can be theoretically of this efficiency, but its one-sided feature renders this misleading.

I received my first knowledge of the type of joint shown in Fig. 3 from the illustrations of the boilers of the steamship *Kaiser Wilhelm der Grosse* which were published in *Engineering* nearly twenty years ago. This is illustrated in Fig. 4. The fault of this design is that the straps are too wide and the rows of rivets parallel to the axis of the joint, too far apart.

I have treated this matter at some length in order to lead logically to the conclusion that the plates of the cylinders of boilers can be made thinner than usual by the use of a non-one-sided or symmetrical butt joint.

F. W. DEAN.

### WHY COLLEGE MEN LEAVE RAILWAY WORK

Los Angeles, Cal., February 21, 1914.

TO THE EDITOR:

I know quite a number of college men who entered railroad service; some were well adapted to the work and some were not, but with few exceptions all are now in other businesses.

One young man, of the best type for railroad work, well liked and even complimented by his fellow workmen as having good ideas, left after three months' service, giving as a reason that "a college man is foolish to remain with a railroad; there is no future under the present conditions."

Another stayed one year, half of which time was spent on a bolt cutter and nut facing machines. On asking for a change the foreman told him to "work where I put you." Who wouldn't leave under those conditions?

Another young man, a graduate of one of the best engineering colleges along railroad lines in the United States, bright and ambitious, climbed the ladder till he was one rung below the master mechanic when conditions were set up with which he was unable to cope.

Still another, who had excellent experience in various departments on different roads, was holding a foreman's position. This man was well up on shop work and money-saving devices. The road using his services was very far behind on many things. In talking to the superintendent of shops one day in an off-hand way he suggested an improvement which had been tried out elsewhere and found to be very successful. The superintendent had no desire to hear the suggestion. In a few months a device was put into operation which was much inferior to the one outlined by the foreman.

These are only a few examples I have had brought to my attention. These men failed in railroad work because they were with the wrong company.

E. L. DUDLEY.

### ELIMINATE YOUR METALLIC PACKING TROUBLES

Chicago, Ill., April 11, 1914.

TO THE EDITOR:

In looking back over a good many years' experience in the metallic packing line, both as a manufacturer of metallic packing rings and as a user of them, the thought strikes me that if metallic packings were only given a fair show, much greater mileage would be obtained, and the complaints would be much fewer. The writer has seen within the last twenty years many new metallic packings that were put on the market and a great many that were not. If the few good ones were used right how much easier the life of the packing man would be, and consequently the poor over-worked railroad man would have less cause to complain.

This is the day of specialists. We have all kinds of specialists on railroads, except a packing specialist. The writer knows of only a few roads where the matter of metallic packing, its

application, etc., is dignified by having a specialist attend to it. On these roads they have no packing troubles to speak of, not even with superheaters. Occasionally, of course, a packing will blow, but usually it is a case of the packing being pretty well worn out and a set of new rings will cure the trouble. But how about the other roads where anybody and everybody, and usually nobody, attends to packing matters? Those are the roads that give the packing man all his troubles and gray hairs. He is called in usually as a case of last resort and his packing is blamed for all the troubles. He scratches his head and tries to reason out why his packing works well over on the *A.* road and not here. Finally, when he lands in the roundhouse and calls for cases where his packing has apparently fallen down, he finds that a helper had applied the packing and a handy man had made the cups. The cups were new when applied and so, of course, they must be right, the roundhouse foreman argues. "Well, let's see your cups anyway, just so we can make sure," says the packing man. When he tries his gages in the cups he finds the angles off 5 or 6 deg., the cups much too large, and a few other things of a like nature. The packing man instructs the back-shop to make the cups to a fixed standard and gage; then he gets the consent of the division master mechanic to have a regular machinist attend to all packing matters and see to it that a good packing is selected for the job. At his next visit to the shops he finds that his packing is giving satisfaction and everyone happy.

It is a matter of education, and if the officers would pay a little more attention to these matters much better results would be obtained.

A. E. M.

**WIRING FOR ELECTRIC HEADLIGHTS**

SACRAMENTO, Cal., March 31, 1914.

TO THE EDITOR:

I have read with interest and pleasure Mr. Kropidowski's reply on page 115 of the March issue to my criticism of his headlight wiring diagram. Putting the small chip of wood between the brush and the commutator would put out all the lights, including those in the cab, the number light and the classification lamps, if these were electric, and a little grit on the chip of wood would do considerable damage to the commutator in a very short time. Furthermore, it would be very much easier to shut down the headlight dynamo by closing the throttle than to crawl out of the cab and up to the dynamo to insert the chip of wood, the results being the same.

As to the contact between the arc lamp carbons being intermittent and causing the pilot lamp to flicker, I was calling attention to the conditions with the engine standing on a siding at which time there would be no jarring and the pilot lamp would burn steadily as soon as the arc was cut out if the wiring were arranged as indicated by Mr. Kropidowski.

W. E. JOHNSTON,  
Chief Draftsman, Western Pacific.

[Mr. Kropidowski's reply to this letter is given below.—Editor.]

WINONA, Minn., April 22, 1914.

TO THE EDITOR:

I am sincerely grateful to Mr. Johnston for bringing out the points he has. However, I still do not feel that they make my system of wiring unsatisfactory. It is for the one selecting a method of wiring to decide which would be best suited for his purpose, and which features he is willing to sacrifice, simplicity of wiring or a few minor conveniences.

I agree that the use of the chip is not the best practice, as there are always careless men who would not see to it that the chip was clean; also that the same purpose could be accomplished by closing the throttle, but the throttle should not be shut off any more than is necessary on account of condensation accumulating in the turbine, where it is injurious to

the blades. As to the engine men remaining in darkness, I think this was answered in my previous letter.

Regarding the incandescent pilot lamp flickering when receiving current through the arc lamp carbons, I know from experience that it will not burn steadily even though the locomotive is standing still. The slight vibration due to the exhaust of the air pump etc., will cause the arc lamp carbons to break and make contact.

V. T. KROPIDOWSKI.

**STEP FOR LOCOMOTIVE RUNNING BOARDS**

NEW YORK, N. Y., April 14, 1914.

TO THE EDITOR:

Boilers on modern locomotives are in many cases so large that the front doors of the cab are too narrow for a man to pass through. It is therefore necessary to climb along outside of the cab to reach the running boards. Often the only provision for doing this is the projection of the cab floor outside the cab a half inch or so. A good step may be easily and cheaply provided by

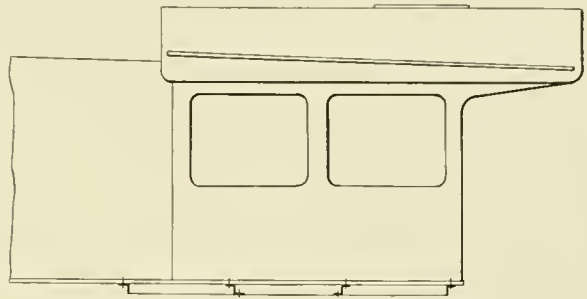

Step Under Cab Running Board

placing a strip of steel 3 in. below the cab floor and flush with the side of the cab, as shown in the illustration. Whether the front door is passable or not this is a convenience in cleaning the windows. Usually the water shed above the windows may be used as a hand rail, but if out of reach a small rail can easily be provided.

WILLIAM G. LANDON.

**TURNING DRIVING WHEEL TIRES**

RICHMOND, Va., March 21, 1914.

TO THE EDITOR:

I have read with a great deal of interest several records of locomotive tire turning on this and other roads, published in the Mechanical Edition of the Railway Age Gazette. We have in our Seventeenth street shops, Richmond, Va., a lathe of the same type as that used at Clifton Forge, Va., and the

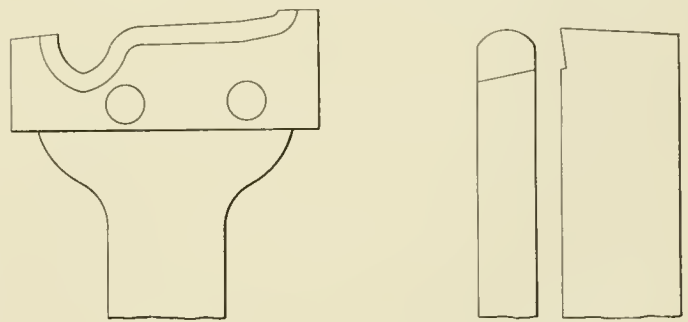

Finishing Tool.

Roughing Tool.

Tools Used in Turning Driving Wheel Tires

Huntington, W. Va., shops, whose records for turning driving wheels were published in the December, 1913, issue on page 640, and in the February, 1914, issue on page 61, respectively. In a test on this work made on March 18 under the supervision of our general foreman, S. C. Moss, we turned four



pairs of 56 in. driving wheels in one hour and fourteen minutes, or an average of 18½ minutes per pair from floor to floor. The quickest time from floor to floor was 17 minutes. The average time for putting the wheels in the lathe was a little less than 4 minutes, and the average time for taking the wheels out of the lathe was an even 2 minutes. The machine used was one of the latest types of heavy duty driving wheel lathes manufactured by the Niles-Bement-

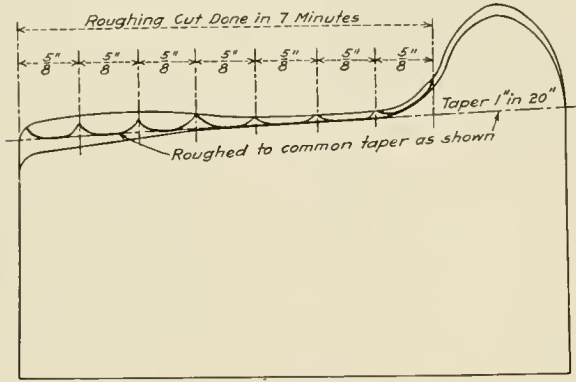

Method Followed in Turning Driving Wheel Tires at the Richmond Shops of the Chesapeake & Ohio

Pond Company, and was driven by a 50 horse power A. C. motor, which did not give us the advantages of variable speeds which may be obtained where direct current is used. The accompanying table gives the report of tests in detail, and the drawings show the two tools used and the methods of turning the tire. The maximum depth of cut was ¼ in.

Pair No.	Time putting in lathe, minutes.	Time roughing and finishing, minutes.	Time taking out of lathe, minutes.	Time from floor to floor, minutes.	Cutting speed in feet per minute.	Feed in inches.	Diameter of wheel, inches.
1	3	14	2	19	15	3/8	56
2	4	13	2	18	to	3/8	56
3	3	12	2	17	to	3/8	56
4	5	13	2	20	17	3/8	56

Average time per pair from floor to floor, 18½ minutes.

M. FLANAGAN,  
Master Mechanic, Chesapeake & Ohio.

QUESTIONS FOR CAR DESIGNERS

MEADVILLE, Pa., May 13, 1914.

TO THE EDITOR:

Referring to the query in the May issue by W. R. N., relative to the calculation of bending moments in the corners of open door framing, I would consider the data given as incomplete. The nature and magnitude of bending moments in the top and bottom door frame members will depend primarily upon the manner of load distribution to the center and side frame members of the car body.

In car body construction, two general types may be found:

(1) The center girder type in which the center sill is designed to meet stresses due to total car body and lading weight plus the draft gear loads. No load is carried by the side frame.

(2) The side frame or girder type, in which the side sill is designed to withstand stresses due to total car body and lading weight, and the center sills to resist draft gear loads only.

From these two general types various combinations of design can be made. A car of the first type need have the side door top or bottom frame members designed to resist bending moments, due to superimposed load only, and on that account would require door frame members of minimum section.

In the second type, however, the side-door frame

top and bottom members would have to be designed to resist total bending moments, due to the weight of the car body and lading at that point. In this type one would expect to find these members of maximum section. A type of car body construction is employed in which the design is of the second type, having side doors located over the trucks. In this case, on account of truck clearances, deep side sills under the side doors could not be used and therefore the bending moments at the door opening are considered as resisted by the center sills at these points.

This type of cantilever construction is used extensively by the Pennsylvania Railroad.

From the foregoing it can be seen that the bending moment to be resisted by the top or bottom door frame members will depend entirely upon the nature of the car body design, and not upon the vertical shear at points on either side of the door. The vertical shear alone is only a criterion of bending moments in so far as we know that where the shear passes through zero or reverses in sign a point of maximum bending moment occurs. I would therefore suggest that W. R. N. determine the bending moment due to total lading and car body load at the door location, and according to conditions distribute this bending moment over the center sills and side framings, with the bending moment assigned to the side frame, considered as resisted by the summated section moduli of the top and bottom door frame members.

R. N. MILLER.

WATERING THE RAILS TO PREVENT SLIPPING

MILL VALLEY, Cal., May 8, 1914.

TO THE EDITOR:

The article on page 178 of the April issue brings to mind a road where water on the rails is a necessity. It is the Mill Valley & Mt. Tamalpais Railway in California, and has a grade 8½ miles long averaging 6 per cent and in some places as steep as 8 per cent. There are 281 curves in this piece of track. If the curves were continuous there would be 42 complete circles made. The longest straight piece of track is 413 ft. Shay geared locomotives are used and water is run on every wheel. The water reduces friction on the curves, reduces flange wear, keeps the brake shoes cool and eliminates all wheel squeaking. The locomotive is always kept on the lower end of the train to prevent breaking in two. When the train is being pushed up grade with the cars in the lead, water is forced by the injector to the leading truck of the first car.

HAROLD S. JOHNSON.

ABANDONING OIL FUEL.—It is announced from Vienna that the authorities of the Austrian North Eastern Railways have decided to give up the use of oil firing on the locomotives, except on those sections of the system where there are steep grades and many tunnels. The decision to adopt oil was arrived at about five years ago, when some 800 locomotives were adapted for burning liquid fuel. The work of converting these engines to coal firing again has already been commenced.—*The Engineer*.

FAST RUN IN IRELAND.—Recently a special non-stop train was run from Belfast to Dublin with the chairman of the White Star Steamship Company, at a speed which constitutes a record for the Great Northern Railway, if not for any line in Ireland. The train was composed of a saloon and a third class van and was drawn by a 4-4-0 type locomotive. The distance is 112.5 miles, which was made in 116 minutes, an average speed of 58.19 miles per hour. Speed had to be reduced to 12 miles per hour on five sections of the line owing to relaying and other operations; to 20 miles per hour approaching Scarva for reverse curves, and at Drogheda on account of a curve and viaduct; and to 30 miles per hour approaching curves at Poyntzpass Station; the train had also to negotiate a heavy incline of 8.5 miles.—*The Engineer*.

# RAILWAY FUEL ASSOCIATION CONVENTION

## Important Papers Dealing with the Most Economical Methods of Handling and Using Fuel

The sixth annual meeting of the International Railway Fuel Association was held in the LaSalle hotel, Chicago, Ill., May 18 to 21. The convention was called to order by the president, Robert Collett, formerly superintendent of locomotive operation of the St. Louis & San Francisco. After a prayer by Dr. T. F. Dornblaster, President Collett addressed the association.

### PRESIDENT'S ADDRESS

The result of the work of this association, in the brief period of six years, has been very gratifying, but its opportunities are so great that we should never feel satisfied. Enough cannot be said to express a proper regard for the work of those few men who at no small sacrifice of their time and energy, built this organization. As a result of these meetings a broader and more comprehensive view is had of the whole fuel problem, and we find the coal man and the railroad man becoming better acquainted.

Recent improvements in mining machinery, especially along the lines of electrical equipment, are giving us coal better prepared on the car. Some improvement has been made in handling through chutes, to secure more uniform fuel on locomotive tenders. We need to specialize more in this direction, and in arriving at the amount of fuel delivered to each locomotive. Any permanent progress along the lines of improved drafting, or for increasing the feed-water temperature before reaching the locomotive boiler, or other devices that will result in causing the position of the locomotive crew to be more attractive, will justify themselves. Recent developments in car design and in the air brake, have made it possible to handle very large trains; the physical ability of the fireman, however, imposes certain limitations on the speed and tonnage.

The proper use of fuel on railroads depends also on other factors. Fuel should be properly prepared for delivery to the engine tank, and a uniform grade of fuel should be supplied where possible. It is fair to assume, where coal mines exist on railroads, that such coal will be used on its locomotives; first, because of lower cost and a constant supply, and second, to stimulate the industry. Efforts should be made to learn to use such coals rather than criticisms made of the quality, as the source cannot be altered. Every semblance of waste should be avoided from the time the coal leaves the mine until it reaches the locomotive tender. If railway managers are shown, concretely, what it costs to operate locomotives not in good condition, the locomotive will not be permitted to long remain in this condition. The proper distribution of engines to divisions to secure the best results, the correct loading of cars and trains, and train movement, should be carefully studied from the standpoint of fuel cost, quite as much as from any other angle. The make-up and schedule of trains is important; it is all along the line of co-operation and needs emphasis.

The plans and specifications for the construction of the modern locomotive are worked out to the minutest detail and when completed it is a magnificent machine. But there lies more opportunity in the finished education of those who are to care for and operate this machine, and not them only, but all whose line of duty affects fuel costs, than was ever known to the builder's art. The time has come when we must conserve our fuel. It is important, in any undertaking, to select good employees; it is especially so in railroad service, and, having selected good employees, the education should be started along fundamental lines at the time of employment. Loyalty should be developed with the other qualifications.

This is an age of co-operation. We are fast learning the lesson that difference of occupation does not imply necessary hostility, and that if we want good service we should cultivate a just pride in duty well done, and should make working conditions as comfortable and, above all, as regular as possible; in other words, cause each employee to be in love with his work. Generally speaking, this is not a difficult problem. Considerable personal observation has convinced me that the average railroad employee desires to do his work in the most efficient manner, but it frequently occurs that he has never had the proper instruction to start him right. Under these circumstances even a willing man is liable to fail, and I believe this will apply to other occupations.

### ADDRESS OF DR. GOSS

Dr. W. F. M. Goss, chief engineer, Chicago Association of Commerce Committee on Investigation of Smoke Abatement and Electrification of Railway Terminals, gave an interesting talk on the significance of a pound of coal, stating that in a first class modern stationary plant one pound of coal will produce very nearly one horse power for one hour, while in a modern superheater locomotive it will only produce one horse power for 20 or 25 minutes. One pound of coal used in a freight locomotive will provide enough energy to carry one ton 15 or 16 miles, and in a modern train it will be fed to the boiler every 52 ft. of distance traveled; in other words, if coal were fed to the boiler continuously it would take a rod of coal  $\frac{3}{8}$  in. square constantly fed into the firebox. In the past the coal production has been doubling every ten years, and if this rate of progress is continued between the years 1910 and 1920 the total production during that time will be equivalent to the production prior to 1910.

In speaking of the work of this committee Dr. Goss mentioned the amount of coal used in and about the city of Chicago. Of 21,000,000 tons of coal or about 5 per cent of the total produced in the country, used in and around Chicago, 1,800,000 tons is anthracite and 3,400,000 tons is coke which comes from eastern sources. Of the bituminous, 4,000,000 tons comes from eastern fields and 12,000,000 from Indiana and Illinois fields. Within the city limits 17,500,000 tons are used per year, a little less than 2,000,000 tons being burned by locomotives. While it is to be expected that locomotives should produce more smoke proportionately to the amount of coal used, on account of the incomplete combustion, the railroads should be congratulated upon the very small amount of smoke they do produce. It has been found that they produce only 20 per cent of the smoke in Chicago. The locomotives in Chicago produce about one-half as much smoke as they do outside of the city limits.

The association was congratulated upon the good work it is doing, and Dr. Goss reminded the members that if they will take care of the pounds of coal the tons will take care of themselves.

### HONEYCOMB AND CLINKER FORMATION

The following is an abstract of a paper by S. W. Parr, professor of applied chemistry, University of Illinois:

In studying the conditions of fusibility of the mineral constituents of coal the composition of the ultimate ash product will throw but little light on the subject if indeed it may not be actually misleading. We must keep in mind the fact that there are two stages in the various transformations that are going on.

Each stage has its own fusion temperature and these are widely separated, and any study of the final stage will have value only



as it may furnish information as to the possible conditions existing in the intermediate stage of the combustion process. I refer here in the main to the iron pyrites or brasses in the coal. If this material is allowed to burn at a leisurely rate until all of the sulphur has burned out, the resulting product is ferric oxide,  $Fe_2O_3$ , and a study of the ash residue in which the iron has reached its final state will not disclose any increased tendency on the part of the ash to clinker.

But studying the iron pyrites in its intermediate stage we find that it very readily parts with one-half of its sulphur content and drops from an indicated composition of  $FeS_2$  to the composition of  $FeS$ . This action does not require any oxygen to remove the one atom of sulphur, which is purely the result of heat and takes place at a temperature between 750 and 900 degs. F. Now the further removal of the final atom of sulphur does not take place at any ordinary temperature and, indeed, requires about 1,650 deg. F. for its rapid elimination; or, provided air in sufficient quantity is available, it will burn out to a resulting product of oxide of iron,  $Fe_2O_3$ , which is not only highly infusible, but does not add anything to the fusibility of its associated mineral matter in the coal. It is this intermediate stage in the transformation, namely, the iron sulphite in the  $FeS$  form, which it seems to me is of vital concern in studying this problem, because it is an easily fusible constituent. Now it must be evident, if conditions are favorable for the formation of this intermediate product, and these conditions are maintained for any considerable length of time, at the high temperatures of the firebox this material will run into clinker.

We have been discussing the tendency towards the formation of clinker on the grate bars. What explanation may that afford for the formation of clinker on the flue sheets? Two conditions must exist in order to furnish any explanation along the lines suggested; first, a chemical condition in which the pyritic iron is transferred only to the ferrous sulphite or  $FeS$  stage. We have already said that this transformation may be brought about by heat alone, but it is also true that to remain in the ferrous sulphide stage it must have an insufficient supply of air, otherwise it would continue the process of decomposition until it reached the oxidized form. Chemically speaking, therefore, we need only a moderately high heat and either a shortage in the oxygen supply or such a limitation in the time element that the oxygen action is incomplete.

We should follow the possibilities a step further at this point. If the ash in this half-way condition should be in contact with the higher temperatures of the firebox or be moved into such a zone by stirring or by the movement of the grate, it is entirely possible that large masses of this intermediate material may fuse over on their outer surfaces and thus exclude the further action of oxygen. With a heat sufficiently high, say about 1,600 deg. F., the sulphur is dissociated and driven off. This liberation of the sulphur causes small gas pockets or bubbles throughout the mass, and this is very characteristic of these clinker formations.

The term "honeycombing" itself is somewhat of an explanation of the chemical processes which are going on. Particles of coal which are fine enough to be caught up by the draft have, in the short distance they may travel, about the right conditions as to temperature, oxygen supply, and the time element, to bring them to this intermediate or easily fusible stage. They are thrown, therefore, against the flue sheet in a semi-pasty condition. The outer surface glazes over, and no more oxygen may reach the interior. They are, however, subjected to the most extreme heat of the firebox, sufficient to dissociate the remaining sulphur which thus passes off as a gas, producing the spongy or honeycomb effect. The iron remains behind, it is true, but as *ferrous* iron, and in this form it readily unites with the silica present to form an easily fusible slag. The same ratio of iron to silica, if it were burned to the *ferric* stage, would represent a combination with altogether different characteristics and a very much higher fusion point.

#### DISCUSSION

From the information brought out by the members' experiences it would seem that the sulphur contents of the coal, the amount of ash, or the condition of the boiler were not the sole reasons for honeycombing or clinker formation. The whole root of the trouble seemed to be in the lack of sufficient air to insure complete combustion. Many cases of bad clinkering and honeycombing have been eliminated by giving the ash pan more opening. It was also stated that where brick arches are used very little trouble is experienced. It was generally conceded, however, that boilers in improper condition; that is, with leaky flues, or full of scale, or with rough projections such as stay bolt heads and roughened ends of flues, would be more liable to honeycomb than if they had been kept in proper condition.

Honeycomb has also been found on oil burners, showing that the trouble was the lack of proper air for combustion in the firebox. S. B. Flagg, of the Bureau of Mines, substantiated Professor Parr's reasoning in regard to the iron pyrites, and stated that the low fusion temperature of the ash was not the sole cause of clinker or honeycomb.

#### FRONT END DESIGN AND AIR OPENINGS OF GRATES AND ASH PANS

M. C. M. Hatch, superintendent fuel service, Delaware, Lackawanna & Western, read a paper on this subject. The following is an abstract:

The front end is a vacuum pump drawing air and gases through the ash pan, grate, fuel bed, firebox and tubes, discharging through the stack and with the exhaust steam jet from the engine cylinders as its source of power. This pump must be capable of creating and maintaining high vacuums. An engine, recently under test at Altoona, showed a maximum smokebox vacuum of 19.6 in. of water, equivalent to 11.32 ounces. This draft was measured in front of the diaphragm; behind it the draft had fallen to 10.2 in., a drop of 48 per cent; and in the fire, to 3.7 in., a reduction of 81 per cent. This indicates that but 19 per cent of the total draft furnished by the front end vacuum pump was actually active at the fire, and leads us to a necessity of design, i. e., that the losses in draft occasioned by friction in the smokebox should be considered and reduced to a minimum. Excessively long tubes will obviously cause greater differences in the draft head between the tube sheets than will shorter tubes of the same or even less diameter. On an Atlantic type locomotive with 2 in. tubes, 13 ft. 8 $\frac{5}{8}$  in. long, 6 in. of draft back of the diaphragm sustained a fuel rate of 100 lb. of coal per square foot of grate per hour; while on a Pacific type with 21 ft. tubes, 2 $\frac{1}{4}$  in. diameter, the same draft burned but 88 lb. of coal. These figures, while not absolutely determinate, indicate what is to be expected when tubes are made very long. A careful consideration of all the data at hand indicates that the ratio of tube diameter to length should be not less than 1 to 110, and that better results will be obtained from large boilers by the introduction of combustion chambers in place of the use of tubes much over 18 ft. in length.

Front ends must have consideration as spark arresters, or more properly, spark killers, as they should be self-cleaning. This means that they must be provided with an ample area of netting or perforated plate, the openings in which will control the maximum size of sparks emitted. The diaphragm must be so arranged that the sweep of the gases under it will carry all solid particles with them, that there may be no accumulation at the bottom of the arch. The drop-stack or petticoat pipe must be so designed and placed as to cause proper cleaning of the table plate.

Front ends must be designed to give equalization of draft through the boiler tubes, and over the entire surface of the fire. They must be constructed, mechanically, in a manner rugged enough to enable them to withstand the punishment in-

dicted by the action of the hot gases, the abrasion of the solid particles of unburned fuel entrained by those gases, and the motion of the locomotive in service.

One tendency of the average engine house force in regard to nozzles should be discouraged, and that is their immediate desire to reduce the size when an engineer reports "engine not steaming." Closing up the nozzle should be a last resort, not to be permitted until all else has been tried and found ineffectual. If the opening must ultimately be reduced, bridges or splits should not be used; bush or change the tip, but leave a free opening for the exhaust jet. Experiments have shown that the more dense this vein of steam, the more efficient it is as a gas-remover; therefore it should not be broken up, but should issue free and unrestricted from the nozzle.

All else being equal, the spark discharge is a function of the rate of combustion which is, again, dependent upon draft intensity. If we must burn 120 lb. of average bituminous coal per square foot of grate per hour, we will have a draft, at the fire, of not far from 3 in. of water. A negative pressure of this degree will, no matter how created, cause small particles of fuel to be carried off from the fuel bed and, in the restricted space of the locomotive firebox, these will not be consumed, but will enter the tubes, be discharged into the front end, and thence from the stack. The amount of solid matter discharged from the stack is large and the quantity and fuel value of this loss as ascertained by some recent investigations has been found to vary from 2 per cent and 1 per cent, respectively, at a rate of 2,000 lb. of dry coal fired per hour, to 14 and 12 per cent, respectively, at a rate of 7,000 lb.

**Grates.**—For the combustion of 120 lb. of coal per square foot of grate per hour in the firebox of a locomotive having 56 sq. ft. of grate area, there will be needed a supply of approximately 25,000 cu. ft. of free air per minute. If we consider that this amount must pass through the grates, that which enters the fire door being neglected, we will find its velocity, when the grate has 30 per cent air openings, must be about 1,500 ft. per minute, and if the air openings in the grate are 50 per cent of the total area, the resulting velocity will be 900 ft. per minute. The principles of efficient combustion will be best served if the percentage of air openings be made as large as possible without causing losses of fuel through the grate. Care must be taken to see that grate bars and grate bearers fit the firebox sheets and each other as they should, that the shaking mechanism is convenient to operate and that it locks the grates level and securely (a tilted finger grate means a burned grate) and that proper attention is given this very important and often slighted part of the locomotive in shop and engine house.

**Ash Pan.**—The proper theory of ash pan air opening can be

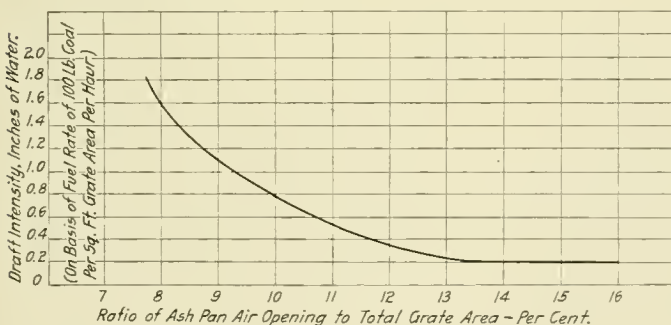

Diagram of Ash Pan Coefficients

enunciated in a few words: Air ingress openings in ash pans should be of sufficient area to ensure the presence of atmospheric pressure under the fire when the grate is working at its maximum fuel rate. The standard practice card of one locomotive builder reads: "The total unobstructed air openings in the ash pan need not exceed the total tube area, nor must they be less than 75 per cent of the total tube area." One of the largest railroads, which

has gone into matters of this sort deeper than any other, has established a standard ash pan opening of not less than 14 per cent of the grate area. Prof. W. F. M. Goss concludes, from data gathered at the locomotive test plant at St. Louis, that "It is evident that after a relation of 0.14 sq. ft. of air inlet per square foot of grate was reached, no further decrease of draft occurred when the air inlets were increased; and when the air inlets were less than 0.11 sq. ft. per square foot of grate, the draft necessary to supply air increased very rapidly."

Let us compare the practice of the locomotive builder mentioned above with that indicated by Prof. Goss. Consider an engine with a grate area of 65.8 sq. ft. and a tube fire area of 8.73 sq. ft.

	Air openings in ash pans, square feet	
	Builder	W. F. M. G.
Maximum .....	8.73	9.21
Minimum .....	6.55	7.23

The maximum of Prof. Goss, shown to give best results, exceeds the minimum allowance of the builder by 29 per cent. In other words, modern engines working with an ash pan air ingress opening equal to 75 per cent of the tube area have but 0.7 as much as they should have, according to what are at present our most reliable data.

Let us compare the performance of two locomotives with ash pans designed according to the above maximum and minimum.

An engine with 65.8 sq. ft. of grate area had 9.2 sq. ft. of ash pan air inlet, equivalent to 14 per cent of the grate area and, under heavy test conditions, when consuming 130 lb. of coal per square foot of grate per hour with a firebox draft of 3.2 in., had but 0.3 in. draft in the ash pan.

A second engine, tested at St. Louis, had a total tube fire area of 6.51 sq. ft., a grate area of 49.9 sq. ft., and ash pan air inlets of 4.95 sq. ft., equivalent to 74.5 per cent of the tube area and 9.72 per cent of the grate area. This engine, under about the same test conditions as the first, showed, while at a fuel rate of 116.25 lb. of coal, a vacuum in the ash pan of 0.64 in. with 2.22 in. in the firebox.

The accompanying diagram shows ash pan coefficients as obtained at St. Louis and also includes data gathered from later tests. All indications here point to the conclusion that an ash pan air inlet equivalent to 14 per cent of the total grate area will give perfectly satisfactory results.

DISCUSSION

The discussion of the previous paper in regard to the openings in ash pans was directly in line with the position taken by the author of this paper. Exceptions were taken to his recommendations that no bridge should be put in a nozzle; many believed that rather than to increase the nozzle openings a bridge will be sometimes necessary to make the exhaust fill the stack.

G. E. Sisco, of the Pennsylvania, gave the following figures from some tests made by that road:

Nozzle	Draft in front of diaphragm	Evaporation per hour
Round .....	10.2 in.	43,702 lb.
Rectangular .....	14.6 in.	49,284 lb.
Elliptical .....	19.6 in.	58,882 lb.

He also stated that the Pennsylvania is making some tests on a new type of nozzle, which is round with four radial arms extending in toward the center for certain fixed distances. The cross section of these arms is in the shape of a triangle, with the apex downward. In stationary tests these nozzles have given excellent results and are now to be tried out in road service. It was pointed out that this new type of nozzle would give a greater surface with which to entrain more of the gas and act as a better vacuum pump in the front end. It was also stated that the conditions under which stationary tests were made did not give an indication of what the draft would be while on the road on account of the wind action as the locomotive passes along at a high rate of speed.

Mr. Hatch, in closing, stated that on a ten-wheel passenger









ticable, to move it to the final destination before unloading, to save the use of cars at the time when the coal is to be used. To do this most effectively the coal should be stored at the coaling stations and arrangements should be made to recover it without involving the use of any cars. This can be done by planning the storage space and devices for handling the storage coal at the time the coaling station is installed. A plant to handle up to 20,000 tons of storage coal will cost about \$20,000. This plant contemplates the use of a bridge and traveling clam bucket, the coal to be taken out of the cars and placed in storage by means of the bucket, the labor to be performed by the regular coal chute force during the dull seasons of the year, so that the labor cost would be a very insignificant item. The coal is then recovered by picking it up with the clam and delivering it on the conveyor chain which discharges it directly into the receiving hopper of the chute.

By operating such a plant the railroad company would secure the benefit of the reduced expense of moving the coal during the dull period of the summer and avoid to some extent the congestion which prevails in the fall, due to the heavy movement of grain and the abnormal movement of coal.

At the time the railroads are storing the coal, which should be either egg or lump, the mines are producing nut and slack (representing from 38 per cent to 60 per cent of the volume of coal stored) for the commercial market, giving the railroads this additional tonnage at a time when they need the traffic and can move it at the lowest cost. As the distance from the coaling stations to the source of supply increases, so does also the amount of the saving resulting from the storage of coal increase. The expense of unloading and reloading is very reasonable, as the experience of railroads that have at different times stored coal as a protection during strikes or suspension of work at mines develops that the work can be done at a cost of ten cents per ton, including cost of tracks, interest on investment for cranes and all other items entering into the expense. The following shows actual expense of one road for unloading and reloading coal at three different stations during the winter and spring of 1912:

UNLOADING							
Station	Tons	Average cost			Track	Total cost	Total average
		Labor	Supplies	Labor			
G.....	9,870	\$293.23	.0297	\$27.10	\$179.27	\$499.60	.0506
H.....	9,396	285.31	.0304	.....	.....	285.31	.0304
T.....	7,373	175.76	.0238	.....	198.77	374.53	.0508
	26,639	\$754.30	.0283	\$27.10	\$378.04	\$1,159.44	.0435
RELOADING							
Labor	Average	Supplies	Total	Total average	Total cost of handling		
					Cost	Average	
\$219.87	.0223	.....	\$219.87	.0223	\$719.47	.0729	
203.41	.0216	.....	203.41	.0216	488.72	.0520	
30.00	.0040	.....	30.00	.0040	404.53	.0549	
\$453.28	.0159	.....	\$453.28	.0159	\$1,612.72	.0604	

This average cost per ton would have been materially reduced if a greater tonnage had been handled at each point.

Contrary to the common belief, coal does not suffer serious losses when exposed to the elements. Exhaustive tests and researches have been made by the University of Illinois and the Bureau of Mines, and the bulletins issued indicate that the calorific loss on coal exposed to the open air for one year or more is not sufficiently great to make the storage of coal prohibitive.

The disintegration of coal is a greater obstacle to storage than the losses in heat value, as there is no question but that the bituminous coals of this country will slack badly when exposed to the elements six weeks or more. This makes the rescreening plant a necessity where coal is stored in large units and subsequently recovered for the market. The ability of railroads and other steam users to procure for storage sizes larger than they ordinarily use, enables them to recover the coal in a satisfactory state for their purposes without rescreening.

When coal is stored in large units great care is required to avoid spontaneous heating. A recent Bulletin of the University of Illinois contains an extensive and complete report, prepared by Professor S. W. Parr and F. W. Kressman, of the results of their experiments and investigation of the question of spontaneous combustion of coal, and all who are interested in this subject should secure a copy of this bulletin. Their enumeration of preventive or precautionary measures to be considered when storing coal are as follows:

a. The avoidance of an external source of heat which may in any way contribute toward increasing the temperature of the mass is a first and prime essential.

b. There must be an elimination of coal dust or finely-divided material. This will reduce to a minimum the initial oxidation processes of both the carbonaceous matter and the iron pyrites. These lower forms of oxidation are to be looked upon as forces, without which it would be impossible for the more active and destructive activities to become operative.

c. Dryness in storage and a continuation of the dry state, together with an absence of finely-divided material, would practically eliminate the oxidation of the iron pyrites.

d. Artificial treatment with specific chemicals or solutions intended to act as deterrents does not offer great encouragement, though some results seem to warrant further trial in this direction.

e. By means of a preliminary heating, the low or initial stages of oxidation are effected. These sources of contributory heat being removed, the forms of destructive oxidation are without the essential of a high starting temperature and are therefore inoperative. Whether such preliminary treatment is within the realm of practical or industrial possibility could not, of course, be determined within the scope of these experiments.

f. The submerging of coal, it is very evident, will eliminate all of the elements which contribute toward the initial temperatures. As to its industrial practicability, like the conditions under *c* above, it can best be determined by actual experience.

g. Other processes may be suggested by the formulation of the principles involved. Such, for example, would be the distribution throughout the coal of cooling pipes through which a liquid would circulate having a lower temperature than the mass. This would serve to carry away any accumulation of heat and confine the oxidation to the lower stages only. On the contrary the proposition sometimes made to provide circulating passages for the transmission of air currents is of questionable value, since it may result in the contribution of more heat by the added accessibility of oxygen than will be carried away by the movement of the air.

*Conclusions.*—The storage of coal carried on successfully means:

More regular working of the mines, resulting in lower cost of production, better satisfied labor, more efficient mining methods and a greater percentage of coal extracted.

Equalized movement, enabling carriers to provide equipment and handle at minimum cost.

Avoiding the spasmodic demands for certain sizes, resultant car shortages, boom prices, sharp practices to escape contract obligations, and the general dissatisfaction resulting from the various causes enumerated.

The consumer should receive sufficient concessions from producer and carrier to offset the expense and deterioration incident to storage and withal enjoy a reduction in the ultimate cost.

Confining of coals to proper distance zones, enabling operators to work out nearby fields more thoroughly instead of mutilating them to get out a little cheap coal to meet the keen competition, leaving a greater percentage of coal in the ground in such shape that it can never be recovered.

The accomplishing of more in the conservation of our coal resources than any other one agent.

#### DISCUSSION

From the discussion it seemed that in the practice of storing coal some members had found no difficulty, while others had found considerable. It was generally believed that coal with considerable slack would not be a good coal to store, and as pointed out in the paper, where the storage of coal is necessary it would be advisable to use large lump, which, when it disintegrated, would not be so small that it could not be used satisfactorily in a locomotive firebox.

Mr. Schaefer, of the Roberts & Schaefer Company, cited an installation for a district in the southwest, where a 50,000

ton storage plant was being built. It is expected that this plant will pay a profit of at least 10 per cent, after 10 per cent for depreciation and 6 per cent interest charges, together with all other costs of operation, have been deducted. This plant is to be stocked in the summer, when the cost of coal is at a minimum, and the coal sold in the winter at the prevailing winter prices.

Where practical it was advised that a good foundation should be made for storage piles, such as reinforced concrete, so that when the pile was cleaned up there would be no dirt and other foreign material picked up. One member reported that coal had been successfully stored, being handled by a locomotive crane at a cost of loading and unloading of about 4.67 cents per ton, with an average depreciation of 2.5 per cent. The kind and size of coal will determine the size of the pile to be made. With slack coal the piles should not be too high, and they should be well ventilated to prevent fires by spontaneous combustion. The coal should also be of low sulphur content. It was believed that good results could be obtained with coal after it had been stored, but different methods will have to be used in firing.

J. G. Crawford, of the Burlington, stated that where possible deep piles should be made, as the deterioration practically only takes place at the top and sides. Tests were made on a Wyoming coal that had been stored four years and it was found that there was practically no loss in heat value, and 18 in. down from the top and 6 in. in on the sides the coal was in as good condition as when stored. The jacking up of tracks over coal piles and running the cars up on the track for dumping was believed to be poor practice, as the slack would settle under the track and create a solid bed, which would be susceptible to spontaneous combustion.

Eugene McAuliffe made a very interesting plea for the storage of coal, stating that by so doing the railroads would receive better service at the mine, being able to get continuous tonnage throughout the year, and much better coal, as the miners themselves, when they found it possible to have steady employment, would be of a more settled nature and more satisfied with their working conditions. It would tend to greatly eliminate the mine troubles that have been so common in the past few years.

#### SIZING OF COAL FOR LOCOMOTIVE USE

The following is taken from a paper by A. G. Kinyon, locomotive fuel engineer, Clinchfield Fuel Company:

A fundamental law or condition for perfect combustion of coal is that oxygen must touch the fuel burned. Not only must the oxygen touch the fuel burned, but the more intimately mixed the oxygen is with the fuel, the more perfect the burning will be. The smaller the lumps or pieces into which a given quantity of coal is divided, the greater the area exposed to contact with the air. It does not follow, however, that the further this is carried the better the results will be. The limit of the smallness of the size of the coal is fixed by the tendency of the fine particles of coal to lie so closely together as to prevent the free passage of air through the fuel bed, rather than to the light weight of the small particles. But this tendency to prevent the free passage of air through the fire also tends to tear holes in the fire. From the writer's experience in firing different coals under various conditions, it has been found that the best results possible are obtained with coal not larger than 2 in. cubes, and preferably with one inch cubes, and it is his belief that this size will give best results when proper methods of firing are followed. Proper methods of firing are believed to be—having a light, level fire, supplying the coal in small quantities at frequent intervals, and distributing each shovelful over as large an area as possible. This brings up another point which will have to be considered. We know that if a shovelful of very fine coal be thrown upon a brightly burning fire, and spread over a large surface, the volatile matter or hydrocarbons will be evolved instantaneously

and there will be little time or chance for them to burn, and much of them will go away in the form of dense black smoke. This, then, is another limiting condition as to the small size of the coal. It is true that by wetting fine coal we can prevent small particles being carried out unburned, but it is difficult to spread wet coal evenly or get it to burn evenly. Not only this, but every bit of moisture in coal must be evaporated before the coal commences to burn, and this takes heat. By this we do not mean to infer that coal should never be moistened; on the contrary, we believe it should be kept moist enough to lay the dust and prevent it from blowing off the tank or into the eyes of the crew.

If we build the fire up to the thickness required to have it burn solidly and evenly with the large lumps, we will have it heavier than it should be for economy. Another objection to large lumps is the fact that it is necessary to put in large quantities at each firing, thus tending to reduce the firebox temperature and possibly bringing it down below the splitting up point of the gases, and they are lost entirely.

Inquiries were sent out in regard to the best methods of preparing coal for locomotive use. Some thought the preparation should all be at the mines and others at the tipples. All agreed that the locomotive was not the proper place to prepare it, at least for hand firing. One correspondent gives \$5,000 as the cost of a crusher installed at a mine to crush run-of-mine coal. Quoting the correspondent: "The rolls of these crushers were 30 in. in diameter and 36 in. long, double roll with inserted teeth  $2\frac{3}{8}$  in. square by  $4\frac{1}{2}$  in. long. The size of the chunks would average 12 in. by 12 in. by 20 in. The coal was very hard. The speed of the rolls is approximately 100 r. p. m. The percentage of sized lump when running through the crusher under a test was as follows: Slack ( $1\frac{1}{4}$  in. round) 10.2 per cent, lump 78.1 per cent, oversize (12 in. by 8 in. by 6 in.) 11.7 per cent. The crusher handles 100 tons per hour and takes the coal just as it comes from the mine, without any labor cost, and the cost for power is practically nominal, being only \$15 for the first month's operation."

The advisability of sizing the coal at the mines or coaling station depends upon the nature of the coal, the number of times it will be handled from the mines to the locomotive tender, and the means of handling it. It is admitted that the fireman gives proper attention to the matter of firing and other duties, such as watching signals, etc., he has no time or inclination to properly break lumps.

Inquiries as to methods of preparing coal for locomotives equipped with stokers that do not combine a crusher in their installation, developed that the preparation was chiefly done by screening. In some cases this was done at the mines and in others at the coal tipples. There is one stoker which will handle either run-of-mine containing 10 in. lumps or slack equally well, having a crushing feature that allows of meeting conditions as they are found, and adding but little to the first cost of the machine and nothing to its complication.

It is the writer's opinion that where coal is machine mined and shot only with powder, the best and cheapest method of sizing for all concerned, will be to pass such coal over a five or six-in. screen. The amount of fine slack coal so mined is negligible and the lumps that pass over the screen can be disposed of for other purposes and at a higher price which will allow a lower price for locomotive fuel.

#### DISCUSSION

J. W. Hardy, formerly of the Rock Island Lines, stated that there never has been such a need as at the present for properly sized coal for locomotive use. The demands made upon the railroads have so materially increased in the past year, with the heavy cars and increased tonnage trains, all at the same rates that prevailed when these conditions were not required, that this could not be performed economically without a good grade of coal of the right size on the loco-



tive tender. Coal chutes should be so designed that the coal would remain well mixed and be of the size intended. Purchasing agents should be made to realize the importance of having the right kind of coal and be shown how a difference of a few cents for a ton of coal might make a material saving in the operation of trains.

W. L. Robinson, of the Baltimore & Ohio, mentioned some tests made on that road with the Street stoker on a Mikado locomotive fitted with a brick arch. It was found that 3.7 lb. of coal were used per horse power per hour, with nut, pea and slack, which passed over a 1½ in. screen, while 4.18 lb. of coal were used per horse power per hour for slack which passed over a ¾ in. screen, showing about a 15 per cent difference and giving a good indication of the value of the proper size of coal.

#### MODERN LOCOMOTIVE COALING STATION

The report on this subject will be published in the July issue. It is signed by Hiram J. Slifer, chairman, E. A. Averill, E. E. Barrett, W. E. Durham, G. W. Freeland, W. T. Krausch and R. A. Ogle.

#### FIRING PRACTICE

The report of the committee on this subject consisted of the entire report submitted last year with such corrections as were requested at the last convention. The report is signed by D. C. Buell, chairman; T. E. Adams, W. C. Hayes, A. N. Willsie, T. R. Cook, R. Emerson, O. L. Lindrew, L. R. Pyle, E. C. Schmidt. The following are the changes made in the report of last year:

*Firing Tools.*—Drawings were presented of shovels recommended, the capacity being from 12 to 15 lb. of bituminous coal. Coal picks were recommended to be about 12 in. long and weigh 4½ lb. Specifications were also presented for a standard rake to be used on locomotives, and for slice and shaker bars.

Other recommendations were included in the new draft of the report, among the most important of which is: "When various kinds of coal are being supplied to engines of a certain district the draft appliances should be designed and adjusted so that the engine can successfully and economically burn any and all of these grades of fuel. In other words, it is not necessary to change the drafting of an engine to burn different grades of fuel successfully."

#### COAL SPACE AND ADJUNCTS OF TENDERS

The following is from a paper by L. R. Pyle, traveling fireman, Soo Line:

The object of this paper is to show how great a need there is for the coal to be delivered to the fireman all the time. Some may take exception to the statement that a fireman will waste 10 per cent of the coal he handles twice, but from my personal experience and observation while riding and firing engines where coal has to be shoveled ahead, I know that this is not exaggerated.

On large locomotives when the full tractive power is sustained for long periods, the fireman should be giving his entire attention to his work in the cab. Just the minute the fireman has to shovel down coal he ceases to be a fireman, and becomes a coal heaver at \$3.75 per hundred miles. All instructions are forgotten and all he thinks of is to shovel coal.

*Types of Hoppers.*—The sides of the coal space should be vertical about one-third of the way and then slope toward the bottom of the coal space at an angle of 65 or 70 deg. An extension of the coping, curving in over the coal space for a distance of about 18 in., is no doubt a help in keeping coal from rolling off while the locomotive is in motion. Some roads using tenders of large coal space, start the slope in the back from the top of the coping down to the shovel sheet at an angle of about 50 deg., instead of having a vertical back to the coal space. Personally, I think this type is the best on large capacity tenders.

*Coal Gates.*—Coal gates should be of iron with a supplementary

gate on the bottom, which should work on a pivot so that it may be raised or lowered at will. Some prefer the gates in four pieces, which is a good plan when they are very high. There should be hooks or cleats on the side of the coal space to hold the gates open. If the coal is not well prepared and contains large lumps the gate should have openings every 10 in. or 12 in. The inverted V-shaped opening in the bottom of the gate should be about 14 in. high and 24 in. wide. We have found that this opening will allow all the coal to pass through. When the coping is high, an arch or yoke should be placed over the gate to keep the sides from bulging.

*Wings or Fenders.*—A fender in the gangway helps to keep coal from rolling out, and should be used, if the apron does not extend too far back. In case the fender is not desirable on account of the element of safety the gates may be set back from the front of the water leg of the tender about 6 in., and this will form a shoulder which will act as a fender.

*Mechanical Coal Passer.*—On one trip while riding an engine equipped with a late type of coal passer, we made one hour and thirty minutes better running time than we could have made had we stopped for coal twice, as would have been necessary with the hopper type of tender. This time was made by being able to make better meets and passing points for passenger trains. Another feature in favor of the passer is that the coal is delivered to the fireman in the best possible condition. There is fresh coal on the tender all the time and the slack and lumps are kept well mixed.

On the tilting type of passer the main trouble reported is that the hinges are weak and break frequently. This may be helped to a great extent by using an oval hole in the hinge, which will make a more flexible joint at the base of the hopper. There are two types of the tilting hopper; one which fits inside the coal space, and one which rests in a bed on the front part of the tender. The latter is much the better type.

The reciprocating plunger type consists of a steam cylinder containing a piston and a rod which is connected to a plunger and a rectangular trough which is placed in the bottom and back end of the coal pit. The width of the trough is practically the same as the width of the coal pit, which is from 4½ to 5 ft.; its sides are 15 in. high, and are provided with flanges overhanging the top of the plunger. Suitable packing is applied to prevent any coal being drawn back of the plunger. The plunger is operated by a lever on the front of the left water leg.

#### DISCUSSION

The moral effect on the fireman of having labor saving devices, such as the coal passers, will be such as to greatly increase his efficiency and will thus be a step toward fuel economy worthy of the expenditure. It would eliminate the necessity of two firemen where two are ordinarily required. The roads using coal passers report that they are very satisfactory. By their use the tenders will not have to be coaled as often, which in some cases necessitates the haulage of coal to outlying points. The coal is also better mixed, as there is no opportunity for the slack to collect.

#### PRE-HEATING LOCOMOTIVE BOILER FEED WATER

Monro B. Lanier, vice-president, Norton Coal Mining Company, presented a paper on this subject from which the following is taken:

That material benefit can be derived from pre-heat properly applied is generally accepted; in point of fact there is probably no more potent factor in locomotive efficiency, fuel economy and boiler up-keep. By pre-heat is meant a reclaimed by-product as differentiated from direct heat applied at the expense of the fuel and heat generating plant. The economy to be derived from pre-heat is in direct ratio as the *difference* between the initial and final temperature of the feed water is to the *difference* between the total heat of steam at a given absolute pressure and the final feed temperature. The percentage of saving varies

inversely with the rise and fall of the boiler pressure, increasing as the difference between the feed water temperature and that of the steam becomes less; it follows that pre-heat will show a greater percentage of economy in connection with locomotives operating at relatively low boiler pressure. Passing over other operating advantages, no claim for fuel economy can properly be made for the increase in feed temperature by means of the injector—the boiler being robbed of steam of high temperature and reimbursed with the condensation, the temperature of which averages 140 to 200 deg. F.

In connection with injector fed boilers, pre-heat to be of value must be added between the initial temperature and the final possible delivery temperature of feed water, the former being the injector delivery temperature, viz., 140 to 200 deg. F., the latter being the sensible heat of saturated steam at a given pressure.

We have included a table expressing in percentage the net fuel economy to be derived from pre-heat from different initial feed water temperatures at a given absolute pressure.

SAVING OF FUEL BY HEATING FEED WATER

(In per cent—Steam 200 absolute, representing 185 gage pressure)

Item No.	Initial Temp. Fahr.	Final Temperature F.								
		120	140	160	180	200	220	250	300	380
1	32	7.93	9.90	11.96	14.09	16.30	18.61	22.24	28.80	40.92
2	60	5.40	7.34	9.34	11.42	13.68	15.84	19.37	25.80	37.63
3	80	3.60	5.50	7.47	9.52	11.65	13.85	17.34	23.65	35.27
4	100	1.80	3.68	5.61	7.61	9.70	11.88	15.30	21.50	32.92
5	120	....	1.83	3.74	5.71	7.76	9.90	13.26	19.35	30.57
6	140	....	....	1.87	3.81	5.82	7.92	11.22	17.20	28.22
7	160	....	....	....	1.90	3.88	5.94	9.18	15.05	25.87
8	180	....	....	....	....	1.94	3.96	7.14	12.90	23.52
9	200	....	....	....	....	....	1.98	5.10	10.75	21.17
10	210	....	....	....	....	....	.99	4.08	9.67	19.99
11	220	....	....	....	....	....	....	3.06	8.60	18.81
12	250	....	....	....	....	....	....	....	5.37	15.29

In practice, with injectors working full, passing water at 140 deg. F. from a tank temperature of 60 deg. F., an increase of 110 deg. by pre-heat, delivering the water at 250 deg. is probably as high as can be obtained, the final delivery temperature increasing to a limited degree with the increased tank and injector delivery temperature.

To offset in a measure the heat losses incident to boiler feeding through the medium of the injector, we must consider the probability of detracting to a certain extent from the tractive power of the locomotive, at least on heavy grades, by any mechanical boiler feed which would necessarily be a pump.

In modern practice, with boilers operating with steam at 200

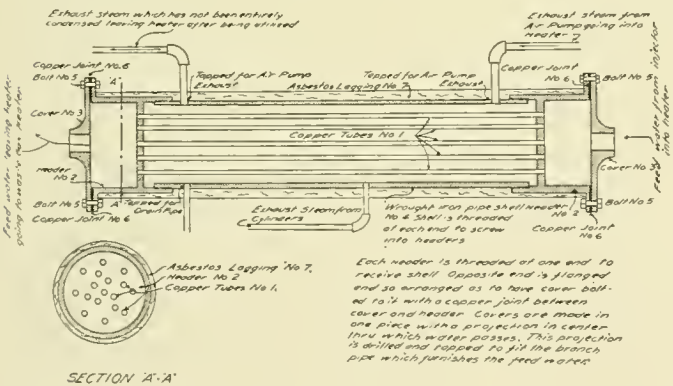

Fig. 1

lb. the metal parts are subjected to high temperature, causing extensive expansion throughout; water suddenly introduced into the boiler at very low temperature causes extreme sudden contraction of the bolts and sheets. The nearer the temperature of the feed water to that of the steam, the less injury will result to the boiler. From a boiler upkeep standpoint alone, pre-heat is of much value and is worthy of careful consideration, especially in view of the fact that the said pre-heat is a utilized waste.

The New Orleans Great Northern is equipping locomotives with a device gotten up in its shops for the purpose of pre-

heating the feed water. The construction and design of this pre-heater is simple, consisting of an auxiliary exhaust heater in connection with a front-end or smoke-box heater operated in tandem. The auxiliary heater consists of a cylindrical shell, Fig. 1, 8 to 10 feet in length, containing a number of copper tubes running lengthwise with the shell; this device is applied on the branch pipe—between the injector and the boiler check—and is connected with an exhaust pipe from the pump. The branch pipe continues from the forward end of the heater through the front end into the lower forward portion of the smoke-box heater.

The front end heater is simply a hollow diaphragm supplementing the regulation diaphragm for each respective engine, yet of the same shape and arrangement with regard to location, etc. The space within the diaphragm is arranged in sections by

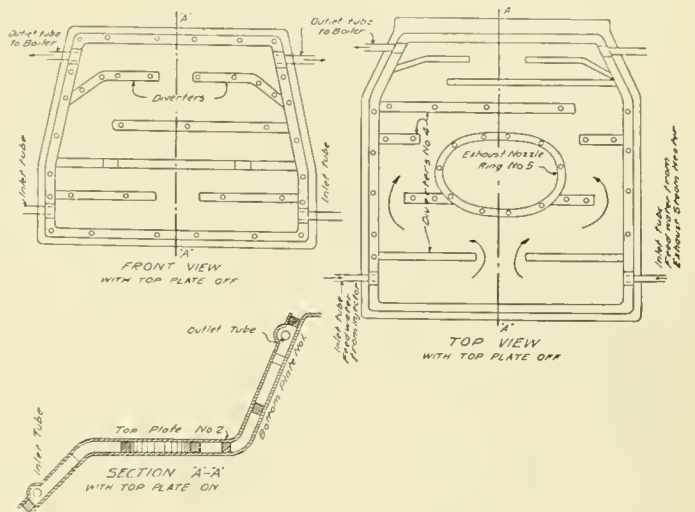

Fig. 2

diverters, placed in such position as to force the circulation of the water over the widest possible area; no set rules are given as to the exact location of the diverters, this being governed by the size and shape of the diaphragm, see Fig. 2.

With the injectors in operation, the feed water passes from the branch pipe through the copper tubes of the exhaust heater, absorbing heat from that steam which is exhausted from the pump into the lower rear end of the shell. The exhaust steam passes upwards over and between the copper tube—the condensation flowing from the lower forward end of the shell through a drain pipe to the ground,—the heated feed water flowing from the copper tubes,—passing through the continuation of the branch pipe—into the front end of the heater—thence upward circulating over the hot flattened surface around and through the boiler check into the evaporative section of the boiler.

Line checks are placed in the branch pipe at both ends of the auxiliary heater, an exhaust pipe to the atmosphere relieving the shell of such steam as is not condensed.

A tee on the branch pipe between the exhaust heater and the front end connects with the boiler check, and valves are so placed on both lines as to divert the feed from the front-end heater at any time this may be desired. A connection is made from the lower portion of the boiler to the smoke-box heater, permitting, when opened, the circulation of water from the boiler through the heater.

It is claimed by the mechanical department of the N. O. G. N. that their engines equipped with this pre-heater are operating more economically, that the heretofore poor steaming engines are now kept hot readily and an even pressure maintained; further, that leaky flues, mud ring and broken stay bolts have been reduced to a minimum.

The following observations were made in regard to delivery



temperature from each heater, and the degree of pre-heat obtained under approximately similar working conditions:

GAGE PRESSURE 185 (200 ABSOLUTE)

Injector monitor No. 10. Operating	Delivery temperature from injector	Delivery temperature from exhaust heater	Delivery temperature, front end heater	Total degrees pre-heat	Percentage indicated economy
Full open.....	150	195	220	70	6.28 per cent
$\frac{3}{4}$ open .....	160	200	220	60	5.94 per cent
$\frac{1}{2}$ open .....	180	210	230	50	5.00 per cent
$\frac{1}{4}$ open .....	210	230	260	50	5.15 per cent
Average .....	160	200	220	60	5.94 per cent

Many of the Mallet locomotives are equipped with pre-heaters which are practically auxiliary boilers contained within the extension front end. Observations made on the Santa Fe System on operating Mallet locomotives indicated an injector delivery temperature of 190 deg. F. and a final delivery temperature to the boiler of 245 deg. F., a gain by pre-heat of 55 deg. F., representing a saving of approximately six per cent.

The Pere Marquette has a number of locomotives equipped so that the exhaust from the pump is discharged into the tank. An average temperature of approximately 100 deg. is maintained in the tank representing an increased average tank temperature of perhaps 40 deg., which is of some value, the injector delivery temperature increasing appreciably. The apparent difficulty involved in this system is the possibility of heating the tank water to a degree that cannot be handled by the injector, and the bursting of the hose connections.

The problem of pre-heating water seems to have received

the lower heater No. 2—from there it flows through the pipe *Q* into the upper heater, thence through pipe *R* to the upper or hot water cylinder, thence through pipe *S* into the boiler.

Two cylinders are necessary for the pump, as the upper heater, No. 1, is higher than the water in the tank, so that it would otherwise be impossible to properly lift the heated water from the heater to the pump.

A safety valve set at 5 lb. is placed on tank No. 2 at *g*, and is connected to the pipe *O* on the tank side of the pump to avoid waste of water; *h* is a safety valve set at 15 lb. as a protection in case valve *g* should not work. Pipe 5 runs to the cab and is connected to a low pressure gage; pipe 8 runs to the cab and is connected with a pyrometer. The outlet pipe from the pump is also equipped with a pressure gage in the cab. With this device at gage pressure of 185 lb. and tank temperature of 60 deg. F. a delivery temperature of 200 to 210 deg. F. may possibly be attained, representing a saving of approximately 13.5 per cent, less the steam loss incident to operating the pump, and any loss from reduction of draft that might be occasioned by diminishing the volume of steam exhausted through the stack. In this connection it is claimed that not more than 6 to 8 per cent of the exhaust is utilized, the supply being automatically adjusted.

DISCUSSION

J. A. Carney, superintendent of shops of the Burlington, spoke of tests being made on that road with a duplex water pump, located on the side of the locomotive, for forcing the water into the boiler. The exhaust on both this pump and the

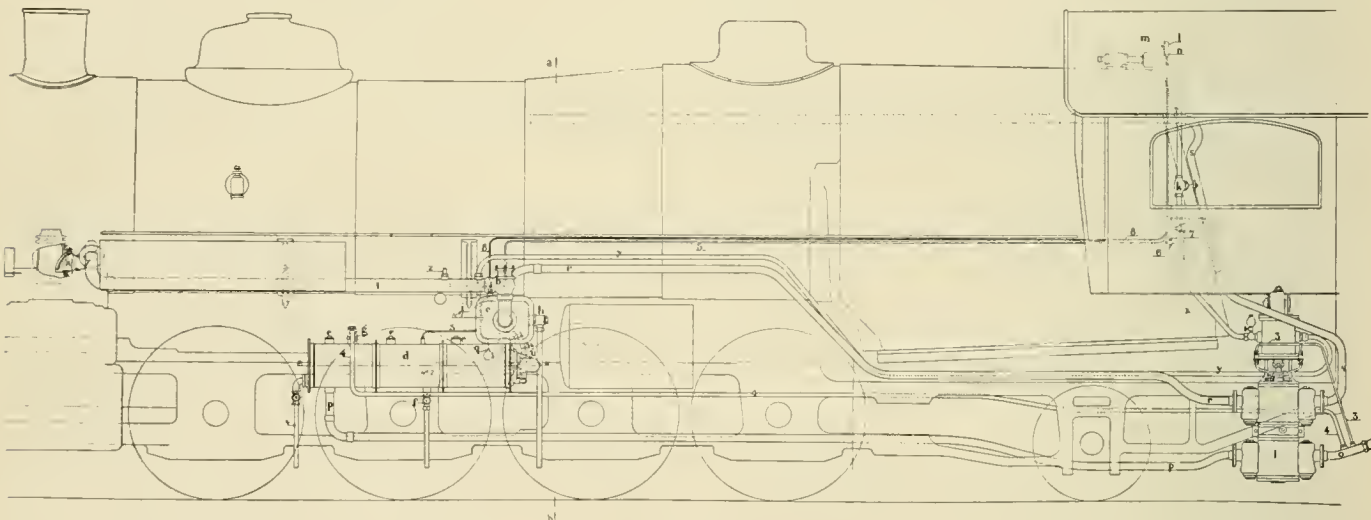

Fig. 3

greater attention in Europe than in America. There are a number of systems of pre-heating in practice on English and Continental lines. One or more of the European devices have been experimented with in this country with more or less success, one of these being illustrated in Fig. 3.

This system eliminates injector boiler feeding, accomplishing this through means of a steam driven pump. The source of the pre-heat is exhaust from the cylinders and pumps.

A part of the exhaust from the cylinder is diverted from the nozzle by means of a shutter or flap valve controlled from the outside of the smoke-box, and is brought through the pipe *T* to the automatic regulating valve *B*, in connection with the exhaust from the pumps which is tapped in at *Y* and *Z* and introduced into the upper of the two heating tanks (1); thence through pipe *U* into the lower heating tank (2), the water surrounding the tubes in the tanks absorbing the heat from the steam, the condensation running out through pipe *V* to the ground.

Water enters the pump through the pipe *O* where it is forced through the lower or cold water cylinder, through pipe *P* into

air pump is used to heat the water in the tank. It has been found that an average of 177 deg. is obtained at the boiler. As high as 205 deg. has been reached and the minimum was 138 deg. With this arrangement it is claimed that 12½ per cent economy is obtained. Some members spoke of turning the exhaust steam from the pump into the tank when injectors are used, care being taken that the temperature of the tank water did not get so high but that the injectors could handle it. Other members have found that this was not satisfactory, as with some grades of water a deposit of scale would be found in the tank.

ENGINE FAILURES ON THE COTTON BELT

A paper by Raffe Emerson on Fuel and Failures was read. This is a study of some results on the St. Louis Southwestern. An abstract follows:

The St. Louis Southwestern, including the Texas division of the road, operates about 250 road locomotives. About 200 of these are in service, the others being spare and shop engines. This represents average present conditions. Thirty-

five switch engines are not included in these figures. Ten years ago there were about 50 engines less than now. The present mileage per year of road engines is about 6½ millions, a little over 4 million of which are in freight service. The yearly total locomotive mileage of road engines ten years ago was not much less than now.

The following is the failure record for 11 years:

Calendar year	Engine failures	Calendar year	Engine failures
1903.....	268	1909.....	95
1904.....	294	1910.....	106
1905.....	273	1911.....	160
1906.....	254	1912.....	145
1907.....	250	1913.....	101
1908.....	132		

It may be explained that the definition of an engine failure on the St. L. S. W. is about the same as for other roads in the same territory. Mr. Adams has succeeded in bringing his engines up from a performance of less than 10,000 miles per failure, to a yearly average of over 65,000 miles, and he has frequently reached as high as 200,000 and 300,000 miles between failures. One case is on record of 503,000 miles without a failure.

The Cotton Belt failure record owes its remarkable improvement chiefly to the following elements:

Elimination of the words "Poor Coal" as an engine failure excuse. Mr. Adams maintains that no coal is poor—that all kinds of coal may be successfully fired if the peculiarities are understood, and sufficient skill is used in handling the fire.

Attempt to eliminate all causes of mechanical failure, by redesigning and replacing every kind of locomotive part that breaks or fails.

A rigid system of inspection of the engine on arrival at a terminal. This rigid inspection is not costly; it is certain in its operation and results, and it pays.

Thorough understanding and co-operation between mechanical officers, shop men, roundhouse men and road men.

**ECONOMIES IN ROUNDHOUSE AND TERMINAL FUEL CONSUMPTION**

A paper on this subject was presented by F. W. Foltz, fuel supervisor, Missouri Pacific. An abstract will be published next month.

**OTHER BUSINESS**

A. L. Mohler, president of the Union Pacific, made a short address during the Tuesday morning session. He spoke of the manner in which some roads are improving the fuel situation consistent with their financial condition, calling attention to the possibilities there are in this connection for the saving of money, particularly where funds are available to invest in this direction. The fuel question should be carefully studied and studied properly, being followed through its course on the railroad from the purchasing agent, who buys it, to the engine crew and others who use it. To obtain the best results there must be the greatest harmony and co-operation between all departments which in any way effect the consumption of fuel. The water conditions must be good, which means heavy outlay, and the coal supply uniform. Care must be taken in train movements, and all correlated matters given thorough consideration. Mr. Mohler was thoroughly in sympathy with the work of the association.

H. L. Cole, assistant secretary of the government railway board of India, attended the meetings and made a brief address on conditions in India. He is making a tour of inspection of American railroads.

M. D. Franey, master mechanic, Lake Shore & Michigan Southern, made a few remarks on the new smoke washing plant at the Englewood roundhouse, mentioning the success with which the installation had been attended.

Mr. Perley, of the Oregon Short Line, addressed the members pointing out how they may greatly assist the railways in forming public opinion by mentioning to the people with

whom they come in contact the real trials and tribulations of the railroads.

J. G. Crawford reported for the committee on fuel tests that very little information could be obtained, suggesting that the roads endeavor to obtain all the information possible as to the efficiency of the different grades of coal, methods of firing, etc.

The secretary's report showed a total membership of 642, with a cash balance of \$885.25.

The following officers were elected for the ensuing year: D. R. MacBain, superintendent motive power, Lake Shore & Michigan Southern, president; D. C. Buell, Union Pacific; J. G. Crawford, Chicago, Burlington & Quincy, and B. P. Philippe, Pennsylvania Railroad, vice-presidents. E. W. Pratt, Chicago & North Western; C. M. Butler, Atlantic Coast Line; W. L. Robinson, Baltimore & Ohio; T. J. Lowe, Canadian Northern; R. R. Hibben, Missouri, Kansas & Texas, were elected members of the executive committee. Chicago was chosen as the next place of meeting.

**FLANGE LUBRICATORS**

BY ROBERT W. ROGERS

There are many devices used in Europe to lubricate driving wheel flanges. The German Railway Administration Society recommends the use of flange lubricators on the forward driving wheels of all passenger locomotives and the rear wheels of locomotives having a tender as part of the locomotive. This class of engine is used in both freight and passenger service.

The lubricator cup is generally placed above the running board and the lubricator so attached that the vibration or the move-

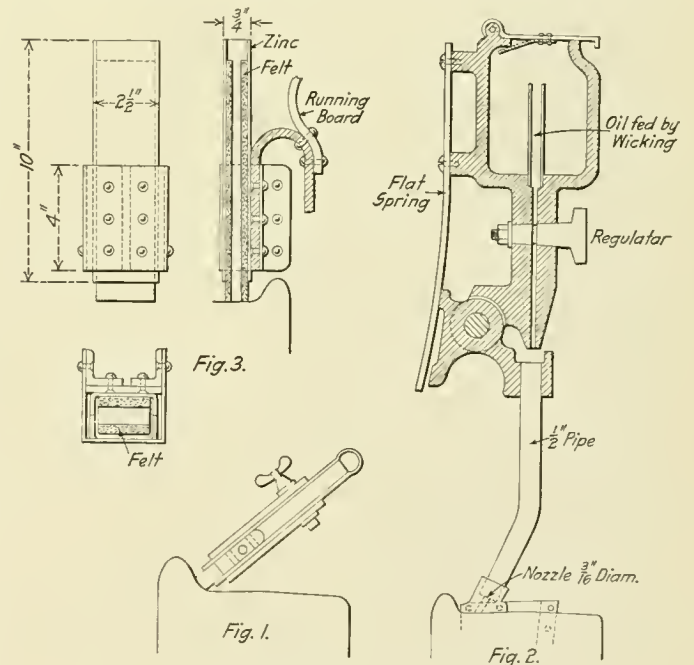

Flange Oilers Used In Europe

ment of the driving springs cannot influence its position against flange. The well known hard grease type is met with quite often, the cartridge being filled with a grease and tarry compound. This is shown in Fig. 1.

Another type is shown in Fig. 2 which has the nozzle guided against the flange by a plate spring in conjunction with a movable arm. This type is fed by crude oil, the flow being controlled by a drip cock. Fig. 3 shows an apparatus used in Austria. In this case the cartridge consists of a sheet of plate zinc filled with felt. Where the valve stuffing boxes are high the oil and water from the swab cup is led to this lubricating cartridge.



# RAILWAY STOREKEEPERS' ASSOCIATION

## Outlines of the Papers and Discussion at the Eleventh Annual Convention Held at Washington, D. C.

The eleventh annual convention of the Railway Storekeepers' Association was held at the Hotel Raleigh, Washington, D. C., May 18, 19 and 20, J. W. Gerber, general storekeeper of the Southern Railway at Washington, presiding.

The convention was opened with prayer by the Right Reverend Alfred Harding, bishop of Washington, after which the association was welcomed to the city by Hon. Oliver P. Newman, commissioner of the District of Columbia.

### THE PRESIDENT'S ADDRESS

President Gerber, in his opening address, spoke in part as follows:

The first two years of the life of this association can probably be best described as a period when we were finding ourselves. This is indicated by the papers discussed at that time. At the convention of 1907, President Rice, in his address to the association, stated that he believed that we have proven to our superior officers, each year, that we are benefited by coming together as an organized body.

What was true then is true today and each year of the life of the association has seen a broadening of the scope of its work, making possible more systematic and intelligent methods in the ordering and handling of material and supplies and an increasing effort on the part of the members to place the work of the stores department on the highest possible plane.

Through the work carried on by the members special interest has been created in the reclaiming of serviceable material from scrap, the elimination of obsolete material from stocks, better methods of accounting, and a realization of the responsibility that is ours in connection with the handling and care of the vast amount of material required in railway operation.

We have seen the adoption by the association of a standard classification of scrap, a standard material classification, standard specifications, classification and inspection rules for railroad construction oak timbers, these specifications having been accepted as recommended practice by the Master Car Builders' Association and Master Mechanics' Association, and adopted by the Hardwood Manufacturers Association of the United States.

While the adoption by the association of a standard scrap classification has reduced the work of the scrap classification committee, I believe that the committee could be profitably engaged in considering suggestions of changes in the classification to meet changing market conditions, and the collecting of information showing the advantages of a uniform classification for scrap material. The classification recommended by the association will not take the place of the various scrap classifications now in use by the railroads until we can show by specific examples that the Railway Storekeepers' classification does possess advantages over the other classifications. The subject is one which concerns every railroad and a great many of our manufacturing plants.

The committee on standard buildings and structures, appointed since our last convention, has already shown the necessity for such a committee, and the information gathered and placed at the service of the lines represented in the association is of great value. Through the work of this committee we can keep in touch with the latest and best designs in the construction of storehouses, oil houses, lumber sheds, casting platforms, scrap docks, etc.

The committee on the book of standard rules will present a report representing a vast amount of labor on the part of the committee members and providing in every detail for a complete stores department organization. No more important work has had the consideration of a committee of this association. I

think we can safely predict that the value of the book of rules will be quickly recognized by all railways and that it will become the hand book and guide in the daily operations of stores departments.

The growth of the association has been very gratifying, and although counting an existence of only 11 years, we now have more than 215,000 miles of railways in the United States represented by membership in the association, the equipment of these lines totaling more than 57,000 locomotives and 2,400,000 cars.

A very large proportion of the railway mileage of the Dominion of Canada and the Republic of Mexico is represented in the association and we also have representatives of the railways of England, Australia, Japan, China, Cuba, Honduras, South and East Africa.

The active membership is over 700. Membership alone, however, is not our principal claim for the benefits arising from the Railway Storekeepers' Association. Rather it is the awakened interest in the daily work of the stores department employees, and the putting into effect of better methods resulting in greater efficiency and economy in railway operation, all of which is being accomplished by the bringing together in one association of representatives of the stores, purchasing and accounting departments.

### FAIRFAX HARRISON'S ADDRESS

Fairfax Harrison, president of the Southern Railway, after a few opening remarks commending the association for the good work it was accomplishing, gave the following address on The Ideal Storehouse System:

No other business enterprise requires so many different things in such large quantities as a railroad, and the importance of the storekeeper in the railroad organization may be measured by the value of the materials and supplies for the safekeeping and proper issuance of which he is responsible.

The statistics of the Interstate Commerce Commission covering railroads having gross revenues of over \$1,000,000 per annum, show that these companies, operating 239,938 miles, had on hand, on June 30, 1913, materials and supplies valued at \$317,773,723, or an average of \$1,324 per mile of road. Including materials and supplies carried by the Pullman Company, this total is brought up to something over \$322,000,000. If we assume that these balances represent a three months' supply, this would mean that your monthly receipts and issues would aggregate something over \$100,000,000 and that you handle during the course of the year property to the value of approximately \$1,200,000,000.

For the successful and economical handling of property of this enormous value it is essential that your business shall be thoroughly systematized in all of its departments, and meetings such as this, where experiences can be compared and suggestions for improvements threshed out, are of practical value to the companies which you represent.

It is the duty of the storekeeper to have on hand and to supply promptly anything that may be required in the operation of the railroad he represents. But the storekeeper must also bear in mind that money tied up in material and supplies is unproductive capital. It is earning nothing while the articles for which it has been expended are lying in the storehouse. On the contrary, storehouse balances are a source of expense to the company in interest, taxes and insurance. The ideal system, therefore, is one which will result in the article wanted being always on hand while the accumulation of an excessive supply of any article is always avoided. I need not tell the members of this association that this presents a difficult problem. It is one,

however, that I believe is possible of solution. In my opinion the solution lies in effective team work, not only within the organization of the general storekeeper, but between his organization and all of the men of other departments to whom materials and supplies are issued. On every large railroad system there are liable to be accumulations of material at certain storehouses while others may be short of the same material, and the general storekeeper may often be able to keep down his total balances by transferring the surplus from a point where it is not needed to the storehouse needing it.

The men who use supplies can be most helpful in aiding the storekeeper to avoid the accumulation of excessive supplies of material in current use and in preventing the accumulation of obsolete stores. The natural disposition of everyone using material is in the direction of accumulating large supplies in order that his work may not be held up while waiting for some essential thing. He should, however, realize that it is to the interest of the company by which he is employed that an undue proportion of its capital shall not be tied up in storehouse supplies and he should loyally co-operate with the storekeeper to keep these down by carefully estimating his requirements.

It would seem that, under an ideal storehouse system, such a thing as the accumulation of obsolete stocks, except insofar as obsolete parts are salvaged from condemned equipment and structures, should be impossible. There is only one way in which it can be made impossible and that is through intelligent co-operation by the users of supplies. The storekeeper should be advised of any change of standard, not when it has actually been made, but as soon as it is in contemplation, in order that he may work off his stock and have a minimum amount of the old standard on hand when the new one is adopted.

I know that there is nothing particularly new in what I have said to you. Much the same ground has doubtless been gone over in former meetings of this association and improvements in practice have doubtless resulted. I think you will agree with me, however, that perfection has not yet been attained and that storekeepers, those who draw on them for materials and supplies, and the executives of the companies should all co-operate to bring about, as nearly as practicable, the ideal condition of having no surplus stock in any storehouse and of always having the thing that is wanted, when and where it is wanted.

#### REPORT OF THE SECRETARY-TREASURER

The report of the secretary-treasurer showed an active membership of over 700 and a balance on hand of about \$700. A number of letters were read from railway presidents commending the work of the association.

#### ACCOUNTING

The accounting committee, consisting of E. E. McCracken (B. & O.), E. L. Fries (U. P.), P. J. Shaughnessy (Erie), H. H. Laughton (So. Pac.), W. E. Brady (A. T. & S. F.), D. A. Williams (B. & O.) and C. C. Dibble (C. C. C. & St. L.), gave a very complete and detailed report on the rules governing the accounting for material and supplies at storehouses. It was divided into four parts—Handling of Materials and Supplies, Accounting for Material Received, Accounting for Material Issued and Material on Hand.

*Discussion.*—A. A. Goodchild (Canadian Pacific) took exception to several points in the report, particularly those pertaining to cash discounts, and second-hand serviceable material.

A member of the committee stated in explanation that it was not the intention in the report to cover the practice in use on any particular road, but the report was given as the most desirable practice to be employed. The president explained that the report was not binding on any road. The report was adopted and referred to the Association of Railway Accounting Officers.

#### RECEPTION BY THE PRESIDENT

On Monday afternoon, May 18, members were driven to the White House, where they were received by the President of the United States.

#### STORE DEPARTMENT EXPENSES

E. L. Fries, auditor of disbursements, Union Pacific, presented a paper on this subject, giving an analysis of the methods which should be employed in distributing various charges to different accounts.

#### STANDARDIZATION OF TINWARE

The committee on the standardization of tinware reported that it is working in conjunction with a similar committee of the Master Mechanics' Association. The report is to be considered at the June convention of the latter association in Atlantic City, after which arrangements will be made for its presentation for the action of the Storekeepers' Association.

#### UNIFORM GRADING AND INSPECTION OF LUMBER

A majority and a minority committee report were submitted on this subject, the latter by W. H. Clifton, Baltimore & Ohio. In the discussion, several members approved the minority report, but many, while holding the belief that it was desirable as an ideal toward which to work, questioned its practicability. The minority report took the stand for inspection of all lumber at the point of shipment, and the differences of opinion hinged mainly on this. W. F. Jones (N. Y. C.) suggested the formation of a bureau for the inspection of lumber at the mills for all railways. This, it was claimed, would largely do away with the increased expense and the difficulty of keeping inspectors busy when inspection at the mills is carried out by the roads.

It was finally moved that the members of the committee get together and endeavor to arrive at an understanding. This was done and the amended majority report was adopted as recommended practice and referred to the American Railway Association. Following is the amended report:

The committee on uniform grading and inspection of lumber were requested by the executive committee, first, to make a recommendation as to whether material inspection should be done at destination or at the point of shipment, and second, to report on the uses of various woods in place of oak for stock and box cars.

The committee is unanimous on the following:

(1) That all piling and track ties should be inspected when received and loaded at shipping points.

(2) That all material which is termed direct shipments, that is, shipments for construction, whether it be bridge or building material should be inspected before loaded or rather at the shipping point, for the reason that it is seldom that there are practical men where the material is unloaded to inspect and receive it and if such is the case, inferior material is often accepted and used.

(3) Lumber which is shipped direct for any purpose ought to be inspected when loaded at the shipping point. To illustrate: The Missouri Pacific runs through a timber country. The probability is that 75 per cent. or more of its switch ties are loaded at the mills and shipped direct to the point where they are to be used. In such cases it is always practical and advisable to have the material inspected at the shipping point before loaded. The same holds true in the extreme Northwest.

[A paragraph was here inserted, replacing a list of the differences between the committee members and recommending the formation of a bureau for the joint inspection of lumber. It was also recommended that after lumber is once rejected, it be not accepted for any purpose.]

The committee reported on the second request that the Chicago, Milwaukee & St. Paul has been using Douglas fir in place of oak for the following purposes:

For Stock and Box Cars: Sub sills; nailing strips; eng. plates; carlines; cross ties; needle beams; side braces; end braces; ridge pieces; cornice side; belt rails, end and side; side door headers; side door cleats; end door cleats; stock car slats, side and end.

For Locomotives: Pilots and pilot slats; running boards; foot



boards and steps; cabs; bumper beams; longitudinal sills for tenders; foot boards; foot steps and coal gates for tenders.

Other roads in the Northwest and Canada have been using maple for draft timbers and find that it has given as good or better service than the average oak which they receive from the South.

### STANDARD BOOK OF RULES

The report of the committee on the standard book of rules consisted of a set of rules comprising a book of 146 pages. This is intended as a foundation for building up a store department on new roads or reorganizing on roads which already have such a department. It is very complete and is a combination of and selection from the best methods now in use on many different railways. It is not intended that it should be binding on any road to adopt it, but the committee believes that with the necessary changes to suit local conditions it forms the best means of organizing an efficient store department. The book was discussed in sections and a number of slight changes suggested. It was finally approved and adopted.

### PIECE WORK

The committee on piece work felt that there was but little to add to what has already been presented to the association in regard to the establishing and maintaining of the piece work or "unit" system of handling supplies and material in the store department. Data were, however, submitted in addition, relating to the best manner of establishing prices and to a comparison of day work and piece work costs taken from actual operations of different railroads.

The committee recommends a form to be known as form R. S. A. 200, as the best means of securing the necessary information on which to base piece work prices. This form should be placed in the hands of the storekeeper, or others in charge, so that whenever it is desired to make a new rate, or change an old rate where conditions have been changed, he may compile the data from actual operations. Before securing such data the storekeeper should study the operation carefully and make sure that there are neither too many nor too few men engaged in the work, and that the conditions are the best commensurate with such expenditure as the management will permit.

The data should then be obtained without the knowledge of the men doing the work in order that it will represent a normal day's work under normal conditions on a day rate basis. This is not done with any idea of being unfair to the men, but rather with the idea of being fair in all cases to both the company and the men. Should the men be aware of the fact that they were being watched and time observed on the operation which they were performing, it would be a very easy matter for them to regulate their speed so that the data would not be a true representation of a normal day's work, hence the price would be established on an unfair basis which would sooner or later prove unsatisfactory to the company or to the men. This is a condition that should by all means be avoided, hence the importance of securing data that do represent a normal day's work under normal conditions. As a further precaution this data should be secured by someone who is familiar with the material being handled, who understands men and knows how to handle them and what they should be able to accomplish under normal conditions in the handling of such material. There should be at least five operations observed on each schedule, and ten are better if time and opportunity will permit. It is not fair either to the company or to the men to establish a piece work price on one or two operations, for the reason that there is a liability of making a price either too high or too low. Too much care cannot be exercised therefore in establishing prices, for, while it is an easy matter, so far as the men are concerned, to increase a rate it is a very difficult matter to decrease one, without creating dissatisfaction, unless there has been a change in conditions.

The data to be obtained and entered under the different column headings should be as follows:

*Date.*—The date the operation is performed.

*Number of Men.*—The total number of men engaged in the operation.

*Hours Each.*—Total hours each man works on the operation.

*Total Hours.*—Total hours for all of the men.

*Material—Quantity.*—Quantity of material handled under the operation.

*Material—Unit.*—The unit under which the material is handled.

*Hourly Rate.*—Hourly rate paid the men on a day rate basis.

*Remarks.*—Any additional information.

*Average Cost.*—The average cost per unit as indicated by the totals for all of the operations.

The storekeeper will then recommend the price in the space provided. In all cases the storekeeper personally should make his own recommendations for piece work prices and in no case should this authority be delegated to another member of his organization.

There are two blank lines provided for a full description of the operation on which the price is desired. This description should not only outline the kind of material to be handled but should state the kind of car, distance carried, and all other conditions which affect the operation.

After the data have been secured, form R. S. A. 200 should be made up in triplicate, the original and duplicate being sent to the general piece work inspector for his approval or disapproval, and the triplicate retained by the storekeeper. In all cases approvals should be made by personal signature of the storekeeper on these requests for prices. If the prices recommended meet the approval of the general piece work inspector he should instruct the storekeeper to make up form R. S. A. 201 (which is a reconstruction of form A as shown on page 147 of the 1910 proceedings of the Railway Storekeepers' Association), in quadruplicate, sending the original and two copies to the general piece work inspector with the original and duplicate of the data sheet attached, retaining the fourth copy for his file. The general piece work inspector should then approve and forward all papers to the general storekeeper or other official for his approval. If, however, the price recommended by the storekeeper does not meet with the approval of the general piece work inspector he should investigate further before authorizing the issuing of R. S. A. 201 to cover.

As a further argument in favor of the piece work system of handling material the committee secured and presented with the report comparative data on a number of operations showing the cost per unit on a day rate basis as compared with the cost on a piece work basis. These data were furnished from actual operations and showed the saving which it is possible to effect under the piece work system from a financial standpoint.

### DISCUSSION

The report was accepted and adopted as recommended practice. A rising vote showed that of those roads represented at the convention, the New York Central, Atlantic Coast Line, Philadelphia & Reading, Chicago, Indiana & Southern, Burlington, Toledo & Ohio Central, the St. Paul and several others use a piece work system in handling stores.

### EFFICIENCY FROM STORE DEPARTMENT EMPLOYEES

Three papers were presented at the convention on the subject of How to Obtain the Greatest Efficiency from Employees in the Store Department. The following is taken from a paper by W. D. Stokes, general storekeeper, Central of Georgia:

Irrespective of the convenience, at times, of having it otherwise, the stern fact cannot be evaded that there is no period in any business career which may be correctly characterized as that of standing still. Progression or retrogression is invariably in process, no matter how imperceptible.

A generally accepted precedent in the organization and conduction of affairs, military, civic and commercial, is that the per-

sonality of the leader enters largely into their success and it would, therefore, appear as a logical sequence, that one of the fundamentals in obtaining efficiency in any undertaking is a careful consideration of the requirements of the person to be selected to act in the capacity of executive.

Organization is largely a matter of instinct, experience and common sense in the selection of subordinates who are capable of fulfilling the requirements, judgment frequently of necessity being deferred, and the systematic assembling of forces in accordance with a definite plan as to what is necessary to conform to the contemplated system.

The diversity of opinion as to detail of the type of organization best adapted to requirements is so great, and the results as obtained from diametrically opposite arrangements are so uniformly satisfactory, that it would appear that this subject has nothing in common therewith and that the principal point at issue is how best to regulate and inspire to bring about an economical and satisfactory conservation of the material and supply investment, and distribution and accounting for it, without embarrassment to operation.

However, no matter how carefully the organization is planned failure to observe certain injunctions will cause the work to go for naught.

It is impossible to successfully lay down hard and fast rules for the entire government of any body of employees, local conditions and temperament, if no other reasons, making this prohibitive and, while it is conceded that discipline is an absolute essential, other important adjuncts should be brought into play. Uncontrollable temperament has no place in the daily walk of successful business life.

Inspire by precept, example, fair play and personal interest that confidence essential to efficiency, without which no organization can hope to succeed, and the encouragement resultant therefrom will bring a loyalty and willingness which cannot but be productive of results. As you regard your subordinates, so you may expect others to do. Disparagement by inference, or otherwise, exerts a contaminating influence difficult to overcome. Disloyalty or indifference may be quickly bred by such tactics and the most carefully built up organization disrupted. Forbearance therefore should be cultivated.

Application is worthy of a prominent place in the consideration of this subject, as without this sterling quality there is little hope for success, either upon the part of the executive or the organization. The misguided idea that affairs are in such shape as to automatically conduct themselves or, at worst, require supervision of only a superficial character, is a fallacy which has frequently caused otherwise perfectly capable men to wonder why some of their fellows were getting the promotions. It can safely be said that the only thing a department will do automatically, is go to pieces.

The following is taken from a paper on the same subject by F. R. Brown, Oregon-Washington Railroad & Navigation Company:

Supplementing this subject let us consider when the greatest efficiency has been obtained from employees of the store department.

The store department has attained a high degree of efficiency—

(1) When it has, by careful calculation and the exercise of good judgment, anticipated the regular requirements of its customer, the railroad, and stands ready to deliver the goods on demand.

(2) When the stock carried is a minimum.

(3) When purchases or other sources of replenishment are a minimum. This is interlocked with the subject of paragraph (2), but it goes deeper, because a large percentage of purchases does not affect the storekeeper's books.

(4) When the investment of the railroad's funds in material is wisely proportioned to the demand therefor.

(5) When material received is of the grade or quality specified

in the purchase order, whether covered by written specifications or not.

(6) When requisitions are intelligently questioned, when necessary, intelligently filled and as nearly as possible to the time of actual use; also when the material furnished is that which is best adapted to the purpose or circumstances, and not higher in grade, and therefore in cost, than is actually necessary.

(7) When deliveries or shipments of material are followed up to see that salvage is given into the custody of the store department and that such salvage is most economically disposed of. In order to secure best results in this, I believe that requisitions should be printed with a detachable numbered salvage coupon so that where salvage cannot accompany the requisition for new material, the coupon can be detached and held until such time as the salvage does come to hand.

(8) When scrap piles have been searched for the recovery of all salvable material.

(9) When attention is called to instances of misuse or abuse of the company's material when observed, even though it has passed from the custody of the store department.

(10) When the actual cost of handling stores is a minimum.

(11) When the difference between value of actual stock on hand and book value, as disclosed by the annual inventory, are a minimum.

(12) When conservation of lumber and other material is practiced to the extent of securing the highest possible class of service from it at every stage, from new to what is frequently mis-called scrap.

This list could be doubled without reaching the limits of the store department's possibilities. The adoption of these twelve principles, and the addition to them of any others that suggest themselves is recommended; also that they be printed and a copy furnished to each employee.

This subject was also dealt with by E. J. Roth, general storekeeper, Chicago, Indianapolis & Louisville. He said in part:

From the many definitions of an efficient store department, I would select the following: An efficient store department is one which is so organized and operated as to be able to promptly supply the proper material to be used by employees in any other department of the service, with the minimum cost to the company, considering not only the physical handling and the actual accounting for the material, but the interest on the money invested in the material itself, in the buildings and yards for its proper storage and appliances for its economical handling, together with the loss due to depreciation in material and facilities, necessary insurance, and all incidental expenses.

I can conceive of a store department organization which would be far from efficient in the sense of this definition, although composed of many individuals efficient in so far as that they properly performed the duties assigned to them by the persons under whom they worked.

The individual efficiency of its employees is of value to a railroad company only in so far as it increases the earnings, or decreases the expenses of that company, and the team work obtained through proper organization with clearly defined duties and responsibilities for its various members and providing for proper supervision must be secured if real efficiency is to be had.

The proper arrangement of material in store houses and yards, from the standpoint of accessibility, including the systematic grouping of material of the same general kind in a definite order, is essential.

A most important factor is uniformity. When applied to a store department, this is a very broad term. The most economical and otherwise satisfactory manner of ordering and receiving material should be determined and this method essentially followed at all store houses and material yards.

Employees of a department, the methods of which are uniform at all points, can be transferred from one store to another, and take up the work of the new position effectively at once



without loss of time in teaching them the methods in use at their new location.

Efficiency from unskilled laborers employed in the physical handling of heavy materials in considerable quantities can be secured by a proper piece work system for payment of the men. I do not wish to be misunderstood in this. Piece work is not a panacea for all of the ills besetting a storekeeper; in a ware-room where small quantities of many different kinds of material are handled it is of doubtful value, to say the least.

The securing of individual efficiency from unskilled laborers is simple in comparison with the difficulties encountered in securing efficiency from the more important members of the store department organization, the ware-room men, the stockmen, clerks, foremen and storekeepers. These men constitute the backbone of the organization. By the results of their efforts the department will, in a great measure, be judged. The men to fill these positions should be selected with great care. To aid in their selection and education, for the particular work for which each shows particular fitness, an apprentice system carefully planned and even more carefully followed up should be of material assistance.

Not many years ago, it was possible to obtain from our laborers' ranks, men who could competently fill the positions of foremen, and could, in many cases, continue on up to the top of the organization. Needless to say, few if any of the foreign laborers we must use in most localities today are capable of this. We cannot get young men of the proper caliber to eventually fill executive positions, to work on the same basis as these foreigners. We must make them see that they will receive special education and attention, and reasonable advancement. A proper apprentice system provides such inducements.

#### OTHER REPORTS

S. C. Pettit, stationer, Grand Trunk Pacific, read a paper on the Handling of Stationery. The Committee on Recommended Practices presented a brief progress report. The Committee on Scrap Classification was not in position to report at this convention. J. G. Stuart (Burlington) explained a loose leaf stock book used on that road which is printed to obtain uniformity in naming parts and avoid copying each month. The Committee on Standard Buildings and Structures showed a number of photographs with dimensions and data regarding storehouses, making possible a choice to suit conditions in establishing a new storehouse. The Committee on Marking Couplers had no definite report and was continued.

#### OTHER BUSINESS

On Tuesday, May 19, the ladies were taken in auto buses during the morning to visit the principal points of interest in Washington, and in the afternoon all those in attendance at the convention were taken by boat to visit Mount Vernon and Marshall Hall, Md., where a Potomac river supper was served. This trip was under the auspices of the Chamber of Commerce of Washington.

#### ELECTION OF OFFICERS

The following officers were elected: President, G. G. Allen, Chicago, Milwaukee & St. Paul; first vice-president, H. C. Pearce, Seaboard Air Line; second vice-president, J. G. Stuart, Burlington.

The Railway Materials Association elected C. B. Yardley, Jr., president, and J. Parker Gowing, secretary-treasurer.

**ELECTRIFICATION OF GERMAN LINES.**—In order to relieve the congestion at the large main station in Hamburg, Germany, a proposal is to be embodied in the next Prussian railway budget for the electrification on the Hamburg-Altona-Blankenese single-phase system of the suburban line to Bergedorf and Friedrichsruhe. The work is likely to be completed in two or three years, and will form an extension of the lines already electrified.—*The Engineer.*

## PERFORMANCE OF FRENCH PACIFIC TYPE LOCOMOTIVES

The following statement regarding the work done by superheater compound Pacific type locomotives on the Paris, Lyons & Mediterranean is made by M. Maréchal, the locomotive engineer of that road: It is true that on the fastest trains, such as the "Côte d'Azur Rapide" and the "Calais-Mediterranean Express," our Pacific engines are underloaded, but that is done with the intention to allow these engines to easily make up time when the train is late. This consideration is very important on such long runs as from Paris to Vintimille; on such a run (700 miles long) there is always the possibility of having some block signals against you for slow orders on account of maintenance of way, or for a delayed freight train, the side-tracking of which was not completed on time, and so on. This is still more necessary when you consider the Calais-Mediterranean express may be delayed on account of the late arrival of the boat at Calais when the weather is bad in the Channel. When these trains are late, the work of our Pacific engines is often very interesting, in spite of their light loads. I give you two instances of such work, one for the Côte d'Azur and the other for the Calais-Mediterranean. Train No. 16 (the return Côte d'Azur Rapide), weighing only 274 (metric) tons, was delayed at Lyon 20 min., but arrived on time at Dijon, the engine, a four-cylinder simple Pacific with superheater, making up 6 min. between Lyon and Mâcon, and 14 min. from Mâcon to Dijon, in spite of a regulation slow down to 25 m. p. h. at Chalon. The run from Lyon to Dijon, 122 miles long, was accomplished in exactly 2 hours, including a 3-min. stop at Mâcon, and the slow down at Chalon. Deducting the stop at Mâcon, but including the slow down at Chalon, gives an average speed of 62.5 m. p. h. for the whole 122 miles run; the continuous speed never fell below 65 m. p. h. on stretches of 22 miles between Lyon and Mâcon, 29 miles between Mâcon and Chalon, 31 miles between Chalon and Dijon; a speed of 68 m. p. h. was sustained on continuous stretches of 11 miles between Mâcon and Chalon, and 13 miles between Chalon and Dijon; the maximum speed attained was 74.5 m. p. h.

Train No. 21 (the down Calais-Mediterranean), weighing 356 (metric) tons, made up 20 min. from Dijon to Lyon, with a four-cylinder compound Pacific locomotive with superheater; 10 min. were picked up from Dijon to Mâcon, in spite of the slow down to 25 m. p. h. at Chalon already referred to, and 10 min. also from Mâcon to Lyon. Deducting the 3-min. stop at Mâcon, but including the slow down at Chalon, the whole 122 miles run from Dijon to Lyon was made in 1 hour 56 min., which gives an average speed of 63 m. p. h., the continuous speed not falling below 65 m. p. h. on stretches of 34 miles between Dijon and Chalon; on 24 miles between Mâcon and Lyon a speed of 68 m. p. h. was sustained; on continuous stretches of 24 miles between Dijon and Chalon, of 13 miles between Chalon and Mâcon, and of 8 miles between Mâcon and Lyon, the maximum speed attained was 74 m. p. h. (the limit allowed by law is 74.5 m. p. h.).

With these "extra rapid" trains, the loads rarely exceed 350 tons, the limit being provisionally fixed at 370 tons for four-cylinder simple Pacific type engines with superheater, and 170 lb. boiler pressure, and at 400 tons for four-cylinder simple Pacific type engines with superheater and 200 lb. boiler pressure, or for four-cylinder compound Pacific type engines with superheater and 227 lb. boiler pressure. For "rapides" or express trains with somewhat slower schedules, regular loads of from 400 to 450 tons are fixed; but overloading is not uncommon on holidays or in the case of the boat trains from Marseilles.

**A RAILWAY FOR ICELAND.**—Hitherto the people of Iceland have used the local ponies as their means of transport, but now a railway is to be built from Reykjavik to the Rangarvalla district, the distance being about 60 miles.

# CAR DEPARTMENT

## HOT BOXES\*

BY O. J. PARKS

General Car Inspector, Northwest System, Pennsylvania Lines West of Pittsburgh

Of the various defects common to car equipment, hot boxes represent the greatest detention to car and train movement. The heating of one journal not only delays the particular car en route, but is often the cause of serious detention to other trains. In addition to these delays it is frequently necessary to switch the car to the shop for the repairs, at a switching cost varying from one to ten dollars, to which should be added the repair cost. It has been stated that the total average cost of the switching and repairs is about \$10 per hot box, without taking into consideration the heavy expense of wrecks due to this cause, consequent delay to traffic, etc. The principal items of the repair cost are renewal of bearing and sponging one or more times, and frequently the removal of the axle for journal truing or renewal, as may be required, which also calls for renewal of both journal bearings and quite often the renewal of journal box bolts. Further, when the wheels are stripped from the axle, many of them are condemned on account of the shop limits for remounting wheels, whereas, if the hot box had not occasioned their removal, they would have continued in service for perhaps six months or a year longer, because of the road limits being less severe than the shop remounting limits.

The following is a record of hot boxes on freight cars on the Northwest System for the last six months of the year 1912 and the corresponding period of 1913:

Month	1912		1913	
	Total hot boxes	Average per 100,000 car miles	Total hot boxes	Average per 100,000 car miles
July	2,583	7.72	2,251	6.33
August	2,542	7.36	2,161	6.14
September	2,789	8.98	1,860	5.82
October	3,027	9.14	1,739	5.26
November	3,519	10.74	1,504	4.85
December	3,583	11.40	1,541	5.55
Total	18,043	9.19	11,056	5.69

The above figures represent the total number of hot boxes, whether or not they caused detentions.

It will be noted that we had a marked decrease in the number of hot boxes for the six months' period of 1913 as compared with the 1912 period. If the average cost of \$10 per hot box is correct, the total number of hot boxes for the six months' period of 1912 would amount to \$180,430, while the total number for the 1913 period would represent a cost of \$110,560, a difference of \$69,870 in favor of the 1913 results.

In the early part of 1913 we started a special campaign against the hot box situation along certain lines, first, to ascertain the originating point of each car developing a hot box, then determine the cause and best way to bring about an improvement. In order to get at the source of the trouble we had our inspectors specify, on their daily hot box reports, the originating point of each car giving trouble, and with this information at hand a traveling inspector was sent to the points from which we were receiving an excessive number of hot boxes, to investigate the conditions and make recommendations for improvement. In addition, we compiled the hot box reports, in statement form, covering five-day periods, showing dates, car initials and numbers, and originating points, these statements being forwarded to the master mechanic of the division on which the cars originated. This information indicates to him the trouble he is sending to the

\*From a paper presented at the May meeting of the Car Foremen's Association of Chicago.

other fellow. This plan has proven very satisfactory in arriving promptly at the responsibility by location, and entails but about 12 hours' labor of one clerk to compile the statements for one month.

The following are the principal causes for journal heating:

(1) The shifting of the sponging toward the outer end of the journal box, due to the lateral movement of the box. When the car is in motion, the end of the axle tends to draw the sponging away from the rear of the journal. An examination of the bearings and axles removed on account of hot boxes will show that heating, in the majority of cases, originated at the rear of the journal.

(2) Sponging too tight, due to an excessive amount of waste, in which case there is usually an insufficient amount of oil, the oil being forced out through the dust guard opening, and in consequence of the dry sponging, the journal is wiped dry of lubrication. In brief, when a box is tightly packed there is no space for the oil. Another feature is that the tight sponging, although not excessive in amount, but jammed between the journal and the side wall of the box, acts as a wiper, preventing the oil reaching the bearing, and not infrequently, strands of waste are drawn under the bearing, causing journal heating.

(3) Sponging glazed, due to dust, etc., and its not being agitated or set up with the packing knife frequently enough, this condition preventing the oil reaching the journal.

(4) Sponging wound in balls, or applied in bulk under the journal with separate portions along each side, there being no thread connections. The top portion acts as a wiper, thus preventing a sufficient amount of oil reaching the bearing.

(5) Insufficient amount of oil in the sponging, caused by it being siphoned away by loose strands of waste hanging out of the box, particularly in warm weather; also, in cold weather, water from snow getting into the box. The water being heavier will lift the oil, allowing it to escape from the box.

(6) Excessive amount of oil, which means an insufficient amount of waste. The sponging as a whole in this case falls away from the journal and the oil, being in excess, is thrown from the box by the revolving journal, or escapes through the dust guard opening, leaving the journal without lubrication, the dust guard opening being below the under side of the journal.

(7) Worn out sponging, short fibre, commonly called "muck" or "mush." This condition gives practically the same results as sponging with an excessive amount of oil, the tendency being for it to settle below the under side of the journal.

These are the most prominent conditions leading to hot box trouble; however, there are many other conditions of less frequent occurrence.

Aside from unavoidable conditions such as floods, etc., there is no occasion for an epidemic of hot boxes. My experience has been that an epidemic usually follows the "let-well-enough-alone" practice, and when the epidemic arrives everybody gets busy and by concerted action the boxes are put in shape, which, however, requires considerable time; then when the conditions become normal the let-well-enough-alone rule is resumed until the epidemic returns again, which may occur two or three times a year. There is no question, but that this system is wrong in principle and that far better results can be accomplished by constant attention to the boxes, and with the same force.

The average man engaged in this line of work is thoroughly



familiar with the common causes of journal heating, and understands the proper method of packing and caring for journal boxes, and I do not hesitate to say that if he will exercise careful diligence and each fellow do his share, the hot box problem will be practically solved. Further, we should not lose sight of the opportunity for taking care of this detail of the car when it is on the repair tracks for repairs of any nature. Statistics show that there are about two and one-third million freight cars in the country, and, on the average, they are shopped about 12 times per year. If thorough attention were given all of the boxes each time the car is on the repair track, it would not be necessary to use so much oil and sponging while the car is in service.

I am a strong advocate of the use of prepared sponging, together with the proper use of the knife and hook, instead of the indiscriminate use of the oil can. However, I appreciate that the oil can may in some instances be used to advantage where the sponging is in proper position and in good condition, but lacking oil. On the other hand, if the oil can is indiscriminately used, the sponging, when not in good condition or not in its proper position, will ordinarily be overlooked, and the introduction of a little oil does not give the results. A few years ago it was the ambition of the average car oiler to use as much oil as possible, as he thought his services were measured by the amount of oil he used, and the result was that a large amount of the oil which was poured into the front of the box escaped to the ground through the dust guard opening in the back.

We have found that the best results are obtained by the use of a packing knife having an effective fish-tail point, in setting the sponging back in its proper position. This should be done promptly on arrival of the car at an inspection point, while the sponging is still flexible from the normal running heat, this prompt attention being particularly advantageous in the winter months. It is also desirable during the warmer months, as other defects can be detected at this time and promptly repaired, thereby avoiding unnecessary delay in the departure yards.

Another feature to which I would refer is the practice followed by some of the roads in marking with chalk, or otherwise, the date of journal box attention, with the understanding that where these dates are within 10, 20 or perhaps 30 days, the box lids need not be raised unless there are external indications of trouble. This practice is entirely wrong. At points where oilers are maintained, all box lids should be raised and if the oiler is competent he can discern at a glance what attention, if any, is necessary. On the other hand, however, I consider that the dating or marking of journal box attention is a good practice in that it affords the local foreman a ready means of check against the work of the oilers. In conclusion, I would say that the most important requirement for control of the hot box situation is eternal vigilance—look out for the back of the box.

#### DISCUSSION

F. C. Schultz contended that the lack of proper attention in the application of wheels is the cause of a great many hot boxes. When they are applied it should be seen that the journals are in perfect condition, and that the brass properly fits them. The most effective way of lubricating a car is with the saturated waste, instead of putting on lubrication over the old waste, and when this is done there should be sufficient help at terminals to have all boxes properly packed.

A. LaMar, Pennsylvania Lines West, said: The Pennsylvania uses a standard form on which is shown the date of the hot box, the point where the car was loaded and the name of the inspector. It shows the initial and number of the car, train number, whether the journal was packed or not, whether the packing was dry, sandy or otherwise, and the condition

of the journal. These forms are sent to the office of the superintendent of motive power, who in turn forwards them to the man packing that car, giving him an opportunity to correct his weak points. About a year and a half ago these reports showed that 65 to 75 per cent of the hot boxes were due to cut journals. In packing the box it should be thoroughly packed inside of the collar and worked forward, and then in front of the journal provide a sponge of waste that has no connection with the waste underneath the journal, so that it will not have a tendency to pull the waste that is underneath to the outside of the box.

We have found by inspection that on about 90 per cent of the cars the packing has worked away from the back of the box. On a freight repair track or in a shop it is important to see that the journals are in perfect condition before they are placed under the car. There have been cases where leaded and even rusty journals have been placed under a car with no pretense being made of cleaning them off. The practice of the Pennsylvania when storing wheels is to use a sediment of oil that is very thick for preventing the journals rusting.

Geo. Thompson, Lake Shore, said: All of the cars on the Lake Shore are packed twice a year, and prepared packing is used instead of free oil. In the confusion in terminal yards it has been found that the oilers are very liable to hurry through their work and thus not do a good job on a journal. We constantly instruct them to take the time necessary to do a good job even if the train is delayed in the yards, as it is better to have it delayed there than on the road. The dates the boxes are repacked are stenciled on the end of the truck timbers. When we started the periodical packing I was very much opposed to it, but after we had gone ahead with it for some time I could not help agreeing that it was a good thing. In the packing which we take from these journals every six months a great deal of babbitt, dirt, sand, etc., are found. The brand new packing is no doubt a very good thing, and costs but little, except for labor. We do not throw the old packing away. After it has drained we shake it up, pick the good stuff out and renovate it with hot oil. We boil the oil out of it, then it is mixed and made ready for repacking.

C. F. Laughlin, Armour Car Lines: We adopted the practice of periodical packing about four years ago, and have largely eliminated the hot box. Not only that; we have accumulated waste, as there is always more taken out of the boxes than is required to properly repack them. Packing boxes too tight seems to be one of the greatest troubles we have. In general, I think the oilers put too much packing in. It also seems to me that it would be a good time to compel the manufacturers to have the name of the box put on the box as well as on the lid; then when the lids are missing we could probably find one to fit the box without much trouble, thus eliminating hot boxes from this cause.

O. J. Parks: In the past six months I have handled perhaps 4,000 reports of wheels removed because of cut journals. Ninety-two per cent of these wheels were removed on account of the journal being cut at the inside end. It is that part that should be given the most careful consideration. The packing for journal boxes should be made up of strands of lengths about equal to one-half the circumference of the journal, and when packing the box this sponging should be distributed equally under the journal and up to within  $\frac{3}{4}$  in. of the center line. The waste should be carefully picked apart so as to prevent its insertion in balls.

CLYDE SHIPBUILDING.—The output of the Clyde shipbuilding yards during the month of March totalled 27,400 tons, spread over thirteen vessels. This compares with 49,000 tons in the preceding month, and 61,000 tons in the corresponding month of last year, and is the smallest March total recorded since 1909.—*The Engineer*.

# AIR BRAKE ASSOCIATION CONVENTION

## Papers on Use of the Caboose Air Gage, Electro-Pneumatic Signal System and Modern Train Building

The twenty-first annual convention of the Air Brake Association was held in Detroit, Mich., May 5 to 8, W. J. Hatch of the Canadian Pacific presiding. The convention was opened with a prayer by the Reverend Chester B. Emerson, and the association was welcomed to the city by Mayor Oscar D. Marx, of Detroit.

### PRESIDENT'S ADDRESS

President Hatch took the opportunity of paying special tribute to George Westinghouse, the inventor of the air brake, who died during the past year, calling the attention of the members to the wonderful genius of the man, and the vast work he has done for his fellow men in the shape of his many inventions, of which the air brake will be his everlasting monument. Attention was called to the need for some means of adjusting the brakes on freight cars. It was believed that by having better regulation in this respect, many of the brake failures would be eliminated and a more evenly operated train would be obtained. If it were found too expensive to put on the automatic adjustment, provision should be made for manual operation. In speaking on the air hose question, he stated that the roads in the very cold climates had not yet obtained a hose that was giving entirely good results in the very cold weather.

The president expressed his optimism as regards the increase of business in the near future, calling attention to the vast amount of traffic handled by American roads. He cautioned the members to take advantage of the dull period by getting their equipment into shape for the rush season in the early fall. In regard to the terminal inspection of the air brakes in trains, he laid particular stress on the success attained by the system followed by the Santa Fe.

H. H. Vaughan, assistant to vice-president, Canadian Pacific, followed President Hatch's address with a few extemporaneous remarks. He spoke of the growth of the air brake, recalling experiences he had had in England with the vacuum brake. He believed that the electrically operated brake would solve many of the air brake troubles of the present time. Mr. Vaughan expressed an appreciation of the work the association has done for the railroads in general, and believed that this association had great opportunities ahead of it.

W. A. Garrett, chief executive officer of the Pere Marquette, followed Mr. Vaughan with some very interesting remarks on the relation of the public to railways, laying particular stress on the present condition of all roads in general, and clearly pointing out that the success of the railroads is a public one, in which the public should be interested and should give all assistance possible. It must never be forgotten that the railroad is a public servant in fact as well as in name, but the service which the railroad can give must depend on the treatment which it receives from its master.

### THE CABOOSE AIR GAGE AND CONDUCTOR'S VALVE

Mark Purcell, Northern Pacific, presented a paper on this subject, an abstract of which follows:

On trains controlled by air brakes, one of the chief essentials is to know that the brake pipe is properly coupled up and charged the entire length of the train, and that the pressure is under full control by the engineer. This points directly to the importance of having all cabooses equipped with reliable air gages, so the trainmen, when in the caboose, may at all times know the amount of pressure in the brake pipe, and have a means of noting the variations when brakes are applied and released, and from this, together with the knowledge gained from the car-to-car inspections made in the standing tests required by the rules, be en-

abled to make a close approximation of the efficiency of the brakes.

The rate of rise in pressure at the rear end of the train when charging up after the brake pipe has been cut for any cause and recoupled, and when releasing brakes after ordinary applications, failure to maintain brake pipe pressure without variation while brakes are not being operated, any considerable decrease in pressure while en route without a corresponding effect of the brakes being felt, etc., are conditions that may be promptly noted; and from the fact that they indicate danger from sliding or overheating wheels, or from the engineer not being able to properly operate the brakes throughout the entire length of the train, the trainmen are warned in time so that measures can be taken to prevent serious consequences. In fact the caboose gage places the men at the rear end of the train on an equal footing with the engineer as to knowledge of what is taking place in the air brake system. This is not only desirable, but necessary, for safe and economical operation. There are many cheap gages on the market, but they seldom render satisfactory service, and the added first cost to procure a reliable article is fully justified by the longer and better service secured.

Provision should be made on all cabooses for easily and quickly applying brakes at times when impending danger to life or property makes it necessary to apply them from the rear, on account of the inability to make known to the engineer the need of a prompt application. The most important features in connection with this are that the valve be of sufficient capacity to cause quick action, and that it be located in an accessible place.

This valve should have the emergency feature only as providing the service application feature would quite naturally be looked upon by trainmen as an endorsement of the practice of making stops by applying brakes from the rear to avoid the inconvenience of transmitting signals to the engineer, and having the application made by means of the brake valve on the engine. It should be pointed out that, the fact of damage to equipment invariably resulting from the promiscuous use of the conductor's valve, does not permit of any excuse for using it in any other than cases of emergency.

It is our opinion that the best practical device for this purpose is a valve that can be opened quickly, and will provide a sufficient opening to insure quick action of the brakes the entire length of the train, or can be opened gradually, and a small amount, to produce a slow reduction to cause a service application, in cases of an immediate stop being necessary, and yet sufficient time available to permit of exercising care to avoid quick action of the brakes, which might, and often does, cause serious damage to the train, particularly when the quick action starts from the rear. When it is found necessary to open the conductor's valve to apply brakes on a freight train, it should be left open until the train stops.

### DISCUSSION

The only objections presented against the use of the gage and conductor's valve in the caboose were that the trainmen would become too confident and remain in the caboose when they should be on the train; also that of the danger arising from applying the brakes in emergency from the rear end of the train. These objections, however, were overruled by other members of the association who had found this equipment to be valuable and satisfactory. Numerous cases were mentioned where serious accidents have been prevented. T. W. Dow, of the Erie Railroad, stated that on his road two runaways had been averted which, it had been estimated, saved enough money in damages to pay for the installation on every caboose on the Erie Railroad. It was not doubted but that the conductor's valve would sometimes be used for other than the purpose it was installed for, but it



was pointed out that if the trainmen were made to see the disastrous results that might accrue from this indiscriminate usage, this practice would soon be stopped. Several members spoke of the inaccuracy of the gages used on some of their cabooses, and believed that they had much better not be installed if they were not of standard and reliable makes, for an incorrect reading might lead to disastrous results. They should be tested as often as the air gages are tested on an engine.

By having the conductor's valve graduated it would be possible to make a service stop where an emergency stop is not necessary. The conductor's valve is specially valuable in backing into sidings, particularly in foggy weather. The gage gives the conductor or flagman at the rear of a long freight train a good opportunity to see just what pressure he has at the rear of the train before starting his train. Many engineers spoke in favor of the conductor's valve, even though they had had experience with their being mishandled. They felt safer with this protection on the rear end of the train. Mr. Langan, of the Lackawanna, believed it was one of the best safety devices that could be placed on a train. The Canadian Board of Railway Commissioners require the caboose gage on all cabooses operating in Canada.

#### FOUNDATION BRAKE GEAR

T. L. Burton, Westinghouse Air Brake Company, opened the discussion on this subject. He spoke of the success that had been obtained with the clasp brake, but at the same time laying particular stress on the fact that it must be applied correctly, for otherwise it would lose its efficiency. In some cases where care had not been given, it had been found that the clasp brake was not as efficient as the single shoe brake. In this respect he mentioned the fact that in applying any foundation gear a careful study must first be made. There can be no standard design for all cars, as the angularity of the rods has a great deal to do with the efficiency of the brakes. Also, the foundation gear should be made to operate as freely as possible, with no binding on any other part of the car.

C. W. Martin, of the Pennsylvania, stated that he had materially increased the efficiency of the foundation gear by eliminating binding in the rods. The gear should be designed to give an equal distribution to all shoes, and also to have the braking power remain the same as the shoes become worn. He had had particularly good success in case hardening the bearings to prevent wear of the parts. The piston travel should always be the same for different conditions, and the shoes should be placed accurately on the tread of the wheel so they will not force the journal out of the brass when the brakes are applied. In speaking of the clasp brake he recommended it for safety and maximum efficiency with the minimum pressure. P. J. Langan, of the Lackawanna, stated that he had, by stiffening the foundation brake gear, decreased the length of stops from 200 to 300 ft.

#### ELECTRO-PNEUMATIC SIGNAL SYSTEM

L. N. Armstrong, Pennsylvania Railroad, presented a paper on this subject, an abstract of which follows:

The present standard pneumatic train air signal used on steam trains has its limitations, and its operation on long trains is far from satisfactory. Where large volumes of air are used the signal valve has to be delicately adjusted; considerable time must elapse from the time the cord is pulled until the signal reaches the locomotive; several seconds must be allowed for the wave action of the air to subside and the line to recharge before another signal can be transmitted; false signals are given, caused by leaks in the signal line, even if the signal line is tight at the beginning of the run, as the long cars now in use when going over crossovers swing far enough to cause leaks at the signal hose couplings. These troubles have been overcome by using electricity as an agent to transmit the signal from the cars to the locomotive.

The signal switch, to which the ordinary bell cord is attached, has two wire connections, one for supplying the current to the

switch, and the other for conveying the current to the magnetic valve in the cab.

The magnet valve consists of an electro-magnet, which, when energized, unseats a small air valve, allowing main reservoir pressure to flow directly to the whistle. A small spring closes the air valve when the current is off.

The whistle has an adjustable bowl, and is the same as that used with the pneumatically operated signal. When using high main reservoir pressure, it has been found advisable to insert a choke in the pipe connection leading to the whistle, having a 3/64 in. opening, to prevent the whistle from screeching.

A combined car discharge valve and train signal switch is designed to cover the transition period on steam trains. It is the ordinary car discharge valve, having a set of contacts added, and arranged so that when the cord is pulled the car discharge valve is opened and at the same time contact is made so that the signal will be transmitted electrically or pneumatically according to which system is used.

A test train, consisting of an engine and twelve steel cars, was operated for a period of four months, on the Pennsylvania Railroad, with such satisfactory results that the electro-pneumatic signal was recommended to be applied to all new equipment.

The electro-pneumatic signal, whether installed with low voltage battery current, or high voltage line current, is instantaneous in its action, reliable, and can be depended upon to transmit signals correctly and distinctly, eliminating entirely the elapsed time between the pulling of the cord and the signal reaching the engineer, no matter how fast the cord is pulled, or how short an interval is allowed between the blasts. With this signal system it would be possible to have a code in which long and short blasts were used, and thus increase the extent of communication between the train and the locomotive without using a large number of blasts. A test was made in which the signal cord was pulled seventeen times in a period of five seconds, and all of the signals were correctly transmitted.

It is free from false signals, and very economical to maintain, having no rubber diaphragms or hose connections to deteriorate, or any parts requiring expert repairmen for delicate adjustments. The operation of this signal on 90 cars during the past six years has shown its reliability and low cost of maintenance, requiring no periodical inspections.

#### DISCUSSION

It was explained further that by placing a whistle on each car it would be possible for the engineer to transmit signals to the train crew which on long trains is of decided advantage, as it is often difficult for the steam whistle signals to be heard from the rear of the train. The air for the car whistles could be taken direct from the train line or auxiliary reservoir and in this way eliminate the signal pipe. If there are no wire jumpers between the cars the wires for this signal could be built in the train line air hose between the inner tube and the outer wrapper.

#### AIR BRAKE HOSE

T. W. Dow, of the Erie Railroad, gave a brief outline of the new specifications of air brake hose adopted by the M. C. B. Association, stating that he believed that if these specifications are rigidly adhered to there will be much less trouble with the air hose than has heretofore been experienced. While this hose will cost a little more than the hose previously purchased, there is no question but that it will prove more economical in the end. He laid special stress on the gaskets for the couplings, stating that he has found that unless they were true to dimensions they would be very inefficient. Too much care cannot be taken to see that the hose is received true to the specifications, and by so doing a great deal of expense may be eliminated and much better results will be obtained.

Other members expressed the opinion that the practice of mounting hose by hand is much more efficient, as the inner tube is not so liable to become ruptured. However, this opinion was not general throughout the association, as many have found

where hose are mounted one end at a time on a machine that excellent results have been obtained. C. W. Martin, of the Pennsylvania, stated that he had made a comparison between hand-mounted and machine-mounted hose, and had found no particular difference in the service given.

Several members expressed the opinion that better results would be obtained by removing all hose after a certain period of time, preferably when the guarantee had expired, as by doing this, although the hose may be in good condition, many failures would be eliminated and the cost of damage to equipment decreased a sufficient amount to pay for the difference in the value of the hose removed. The Duluth, Missabe & Northern makes a practice of removing all hose after two years' service. In comparing the service after this new rule had been put into effect it was found that the hose trouble was decreased by 60 per cent. The Santa Fe reported that they were having as much trouble with the present M. C. B. hose blowing off from the connections as they did before. Some members, however, believed that this might be due to pulling off rather than blowing off.

### MODERN TRAIN BUILDING

George W. Noland, P. C. C. & St. L., presented an interesting paper on this subject, in which he impressed upon the members of the association the importance of placing the light capacity cars at the rear end of the train; also the old cars that are of insufficient strength or that have inefficient draft gear. He cited several instances of disastrous results where this had not been done. He also showed six examples of trains varying from 31 to 80 cars in length, where up-to-date practice in train building had been used or neglected. He then showed how easy it would be to put the bad trains in proper condition, citing instances where this had been done and giving the amount of time consumed.

Special stress was paid to the importance of placing the 40,000, 50,000 and 60,000 lb. capacity older equipment at the rear end of the train. Frequently, he said, this practice has been adopted, even though the weaker equipment was the first to be taken out of the train. He made it clear that in order to get the best results the strictest co-operation must be obtained with the transportation department men, and reasoned that, if the importance of this proposition was presented in its proper light, the transportation department would be willing to allow time to put the train in proper shape. A little more time at the terminal might mean the saving of considerable time out on the road, especially when having to set out cars on account of break-in-twos.

The discussion of this paper was very freely participated in, and the question of the braking force of empty cars was considered. It seemed to be the general opinion that the practice of the Lackawanna and the Santa Fe of mixing one-third of the empties in the front part of the train and two-thirds of the empties in the rear is the best. Several instances were cited where the position of the inefficient equipment had resulted in serious mishaps. Every air brake man should do what he can to see that the trains are made up properly and with as few possibilities of break-in-twos as possible, as they are often held responsible for break-in-twos that are not their fault. They must seek and gain the co-operation of the transportation department.

### AIR BRAKE EFFICIENCY

Fred von Bergen, of the Nashville, Chattanooga & St. Louis, introduced the subject by a short paper, in which he claimed that it was impossible to maintain brakes at 100 per cent efficiency. However, other members brought out the point that by setting a standard of the number of brakes which should be operated in a train and a certain definite degree of effectiveness for each brake as 100 per cent efficiency, this could be maintained. Mr. Wood, of the Santa Fe, explained the system on that road, stating that before a train leaves the terminal all brakes

must be in operating condition, and to this end they have had as many as 100 cars set out at Kansas City in 24 hours, on account of their brakes not being operative. He mentioned that in order to do this the air brake men must have the co-operation of the transportation department, and that if orders are issued, little trouble is experienced in this respect. Before a train leaves a terminal on the Santa Fe it is stretched and the brakes are set so that inspectors may readily determine weak draft gear and inefficient brakes. He stated that at one of the large terminals 16 men split into crews of two men each will handle from 65 to 75 cars per day.

Mr. Sitterly stated that he believed the M. C. B. rules should be changed to make the car owners responsible for more of the brake troubles so that more care will be taken in maintaining the air brakes in good condition. Another member stated that he believed the irregular piston travel gave the greatest trouble, and that prompt attention on the part of inspectors would give the desired results. Mr. Turner concurred in these remarks, stating that a uniform piston travel should be had throughout the whole train, and in addition the foundation gear should be kept in good condition.

The trouble of imperfectly cleaned brakes was also mentioned. This has been evidenced by the defective condition immediately after cleaning. It was stated that on examination out of 500 brakes that had been cleaned 20 per cent were found defective one month after cleaning, which clearly showed that the work had been poorly done.

### DEVELOPMENT OF THE UNIVERSAL CONTROL VALVE

Walter V. Turner, chief engineer, Westinghouse Air Brake Company, presented an illustrated lecture outlining the development of the UC-E triple valve. Mr. Turner showed a number of lantern slides, starting with the simplest form of universal valve, which he called the fundamental valve, and ending with the complete diagram of the UC-E valve, as shown in the illustrations. The illustrations were shown in logical rather than chronological order so as to give a clearer idea of the purpose of each improvement. To the fundamental valve was added the resistance increasing function, the object of which is to give a greater resistance to application than is given the resistance to release. The added resistance to application gives the brake a needed stability against application, which might be caused by unavoidable fluctuations in brake pipe pressure. On the other hand, when a release is desired the resistance to movement is, as it should be, the least possible.

The next development was the service port protection function, the object being to make certain that the auxiliary reservoir will be connected to the brake cylinder when a service application is desired. The next improvement was a redesign so that chokes could be inserted in the service and release ports in order to proportion them to the different sizes of brake cylinders used. This permits of using the same type of valve for different equipment, thereby reducing the number to be kept in stock. The next step was an addition of another slide valve which separates the service and release ports. This was done so as to eliminate the necessity of having a large slide valve which would be necessary for brake cylinders of increased size. The second valve is not directly affected by changes in the brake pipe pressure, but is controlled, instead, by the movement of the equalizing slide valve. The next step was the addition of a passage which, just before the feed groove opens, connects the auxiliary reservoir side of the equalizing piston to the atmosphere. This reduction of pressure insures the equalizing slide valve moving to the full release position, which, in turn, insures the release slide valve moving to its full release position. This eliminates a sluggish release.

The next step was the addition of a quick recharge reservoir. This reservoir is not used in making service applica-



tions, but simply for obtaining a quick recharge of the auxiliary reservoir. The effect of this quick recharge is to keep the brake system charged to its normal pressure at practically all times, so that a prompt response may be secured at any time, to the proper brake valve manipulation. The equalizing slide valve controls the movement of the release piston; that is, the movement of the equalizing graduating valve connects one or the other of the end chambers of the release piston to the atmosphere, which results in the quick recharge reservoir air which fills the release piston chamber, forcing the release piston to assume the position desired. This feature also provides for a graduated release. The quick recharge function insures the conservation of brake pipe pressure, or rather, the most rapid rise of brake pipe pressure consistent with the capacity of the brake valve. This will

In the next step the quick recharging of the auxiliary reservoir was carried to a greater refinement, being necessary when large auxiliary reservoirs are used. The ordinary single auxiliary reservoir is divided into two reservoirs, one called the auxiliary and the other the service. A charging valve is introduced which provides that the auxiliary reservoir shall first be charged, both from the brake pipe and the emergency reservoir. After the auxiliary reservoir is charged practically to the normal brake pipe pressure the service reservoir will be charged along with the auxiliary. The charging valve is so proportioned that when the auxiliary reservoir is within about 5 lb. of being completely recharged, connection is made with the service and quick recharge reservoirs, thus connecting the auxiliary, service and quick recharge reservoirs with the brake pipe. This permits of brake applications in rapid

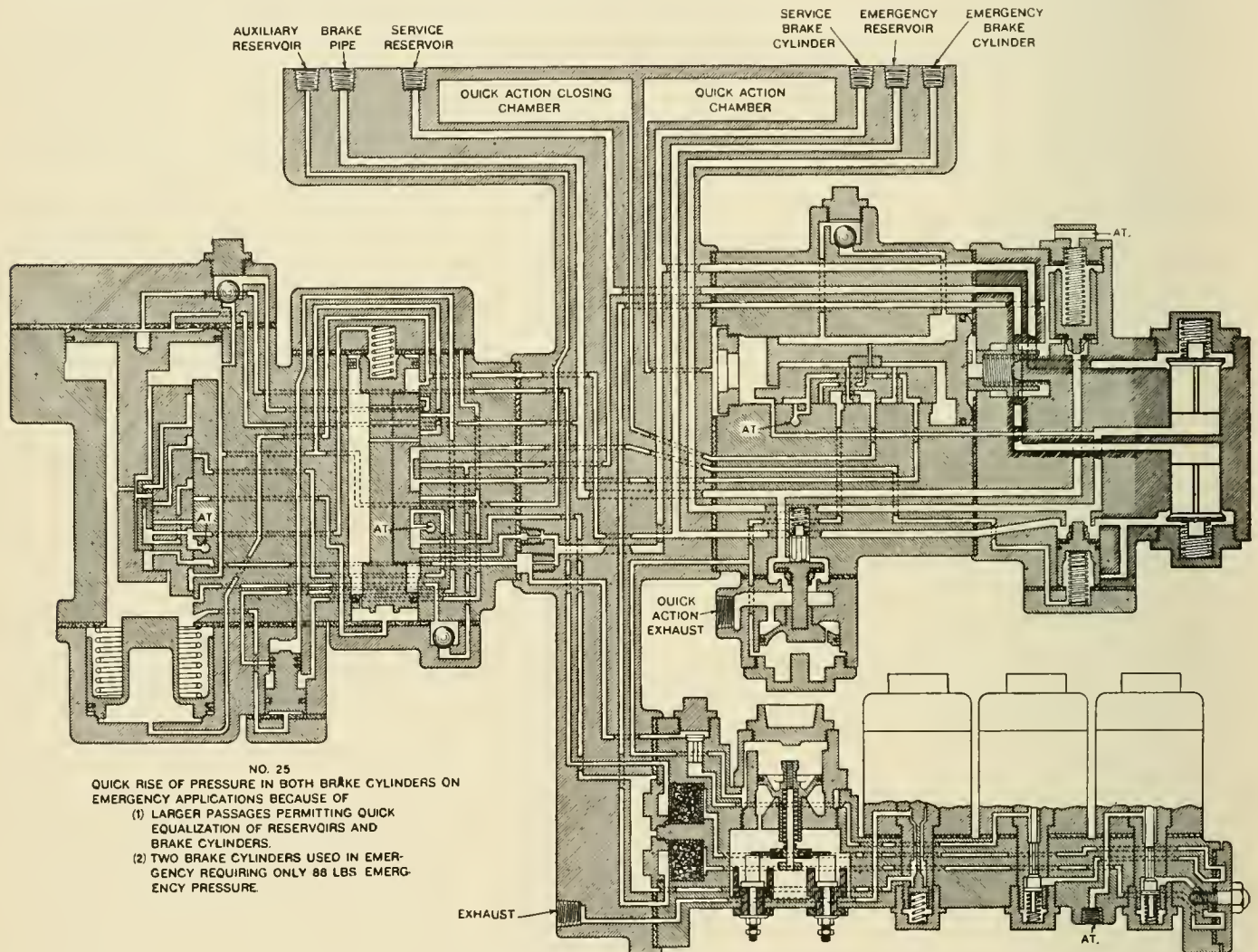

Fig. 1—Final Stage in the Development of the Electro-Pneumatic Brake

tend to eliminate to a large extent the trouble with truck brakes. In trains with mixed cars, some having the graduated release and others not, it may be desirable to cut out the quick recharge function and the graduated release.

The next step was the application of the graduated release stop, which provides that in graduated release the equalizing slide valve shall occupy such a position that the graduating valve can control the movement of the release piston, and that in direct release the slide valve will blank one of the passages to the release piston which will prevent the graduating valve controlling its movements. This eliminates the possibility of the brakes creeping on due to slight variations in brake pipe pressure.

succession and also gives greater flexibility in graduated release. Another function is that when reapplying after a graduated release the cylinder pressure may be so increased as to correspond closely with the brake pipe reduction. This gives the cylinder pressure a constant relation to the brake pipe reduction made, whether in graduated or direct release.

The next development was the quickly recharging of the service reservoir when the valve is arranged for direct release only. This function was introduced because in order to make applications at short intervals it is necessary that the brake system be maintained at as nearly the normal brake pipe pressure as possible.

The next point in the discussion of this valve was the



emergency features. The emergency functions are entirely separate from the service functions, which does away with all trouble from undesired quick action. The emergency slide valve only will operate when the rate of reduction in train pipe pressure is that corresponding to an emergency reduction. The service rate of reduction is only sufficient to cause the emergency slide valve to move to such a position that the quick action chamber air is vented to the atmosphere, which prevents the emergency valve jumping to the emergency position. This also permits of securing quick action at any time regardless of whether a service application has preceded or not.

The next step was the connection by which the quick recharge reservoir is to be used as an additional reservoir for

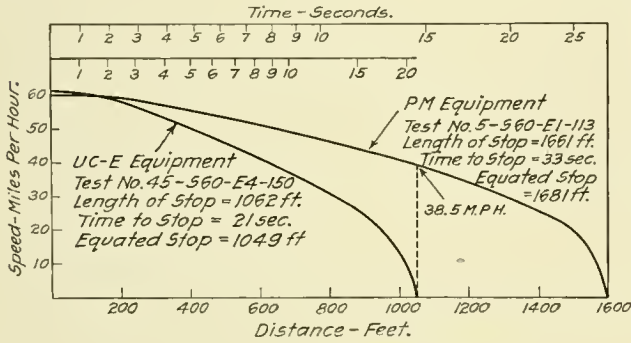

Fig. 2—Results of Tests of Emergency Stops

emergency application. A valve termed an emergency valve is introduced to connect the emergency reservoir to the brake cylinder after the emergency slide valve has moved to the emergency position. Arrangement is also made for the connection between the brake cylinder and the safety valve to be closed so the brake cylinder pressure secured by an emergency application may be retained throughout the stop. In order that the quick action valve may remain open for a time sufficient to reduce the train pipe pressure the desired amount a quick action closing chamber has been introduced. Since the equalizing of pressure of the auxiliary and service reservoirs with the brake cylinders in service stops considers a greater cylinder pressure than that from which the service braking ratio is realized, a safety valve has been introduced to prevent an overcharge of the brake cylinder and thus eliminates wheel sliding.

The next step is the addition of an intercepting valve which in an emergency stop after the service reservoir has been equalized with the brake cylinder cuts off this service reservoir and allows the emergency reservoir to equalize with the brake cylinder. By doing this the disadvantage of increasing the cylinder volume is eliminated. When the emergency slide valve is moved to the emergency position the intercepting valve permits the direct passage of air from the service reservoir to the brake cylinder, and after this pressure has been equalized it will move back to its former position, which connects the emergency reservoir to the brake cylinder, giving the high cylinder pressure desired. A bulb check valve is added to prevent the high pressure from flowing to the equalizing piston chamber which would require a considerable amount of air to release the brake, and delay the release from each emergency application.

The next step is the introduction of a protection valve which is so adjusted that when the brake pipe pressure is reduced for any reason whatever to a predetermined minimum it will open a vent to the air, making an emergency reduction which will set the emergency brake.

The next step was to separate the quick recharge cylinder from the emergency function, the special emergency reservoir being used to give the high pressure necessary in the brake

cylinder, leaving the quick recharge reservoir to give the quick recharge function.

**Electro-Pneumatic Brake.**—The sole function of the electrical control is to secure a simultaneous application of all the brakes, regardless of the length of train, and it in no way increases the braking force obtained from any given brake.

To this final development of the pneumatic brake is applied a magnet valve called the "service magnet," which, when it is desired to make a service application, opens a poppet valve permitting brake pipe air to escape to the brake cylinder. A brake pipe reduction is thus made at each car, the effect of which is precisely similar to the effect produced by making a brake pipe reduction at the engineer's brake valve. The air from the poppet valve to the brake cylinder passes through a choke which gives the proper reduction in the train pipe for a service application. A check valve is inserted in the passage to prevent any back flow of air from the brake cylinder to the brake pipe. The passage leading from the brake pipe to the magnet valve may be cut out when desired, thus cutting out the magnet valve.

The next step is the electrical control of the release. Another magnet valve is provided to control the opening and closing of the exhaust passage from the brake cylinder. When the engineer's brake valve is moved to the release position such connections are made that the release magnet is energized and the magnet valve closed, but the pneumatic release functions are not interfered with in any way. By moving the engineer's brake valve to running position the release magnet is de-energized, which causes the magnet valve to open, permitting the brake cylinder air to escape. With the engineer's valve in holding position the magnet is again energized and the release of air from the brake cylinder stops. Thus it may be seen that the brakes may be released by very small increments by alternately moving the engineer's valve from running to holding position. This also gives an opportunity to permit the brake system to recharge before the brakes are fully released.

The third step in the addition of electrical control is that for emergency application. This valve opens a connection

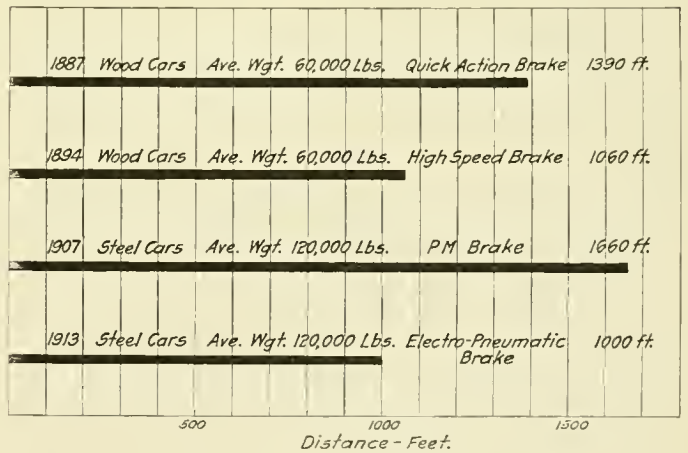

Fig. 3—Comparison of Emergency Stops

between the brake pipe and the atmosphere and operates similarly to the pneumatic operation, except that the action is simultaneous on all cars, the only difference being that it is obtained in much quicker time.

Fig. 1 shows the final stage in the development in the electro-pneumatic brake, with the addition of the electric switch, which operates the emergency circuit whenever any triple valve in the train goes to the emergency position from any undue cause, such as break in hose, conductor's valves, etc. If a higher braking ratio is required for emergency stops than that which one brake cylinder will give, it is possible



to provide two brake cylinders, one for both service and emergency and one for emergency exclusively. Provision is also made for securing a very rapid rise of pressure in both the service and emergency brake cylinders in emergency application. This completes the general story of the development of the universal control electric brake.

Figs. 2 and 3 show the wonderful results obtained by the use of this new type of brake. Fig. 2 is the result of tests with the emergency stop, contrasting the PM equipment with the electro-pneumatic equipment. It will be seen that from 60 miles an hour stops are made with the UC-E equipment in a little over 1,000 ft. at a point at which the train with a PM equipment was running at 38.5 miles an hour.

Fig. 3 shows the comparison in emergency stops at 60 miles an hour with various air brake equipment and typical trains dating back to 1887, 1894, 1907 and 1913. This diagram shows that, notwithstanding that the 1913 train weighed twice as much as the 1887 train, the stop was made in about three-quarters of the distance.

#### ELECTION OF OFFICERS

The secretary reported a membership of about 1,200, and a cash balance of \$1,324.58. The following officers were elected for the ensuing year: President, L. H. Albers, New York Central Lines; first vice-president, J. T. Slattery, Denver & Rio Grande; second vice-president, T. W. Dow, Erie Railroad; third vice-president, C. H. Weaver, Lake Shore & Michigan Southern; secretary, F. M. Nellis, Westinghouse Air Brake Company; treasurer, Otto Best, Nathan Manufacturing Company. New members elected to the executive committee were L. C. Streeter, Illinois Central, and Mark Purcell, Northern Pacific.

## FREIGHT CAR DESIGN AND CONSTRUCTION\*

BY W. M. BOSWORTH

There is no doubt that more economical and efficient designing of freight equipment would result in great saving to the railways. A great deal has been said in the last few years regarding the general and detail design of freight cars, and the standardizing of more freight car parts. This would not only make a saving in maintenance, but would reduce the first cost of the car, and the vice-president of one large car company has gone so far as to suggest the standardizing of all freight equipment.

The railways are in a better position to supervise the designing of cars than the car companies, as they are continually encountering the weaknesses of past designs. Specifications and general drawings should be made in the mechanical engineer's office and advance copies submitted to car department heads, master mechanics and general car foremen to obtain their criticisms and recommendations for strengthening the weak points. The facilities available for car repairing should have little bearing on the design, especially if the road is well equipped with modern car repair shops, as it must be remembered that roads with little or no facilities, as well as the owning road, have to repair the cars.

The failure of car parts should be reported to the superintendent of motive power on specially prepared forms so that proper means can be taken to reinforce the weak points, after a sufficient number of like failures have occurred in fair service to indicate weak design. This will also materially help in framing specifications for new cars. Too frequently the desire on the part of railway officers to cut down the first cost is the cause of weakly designed cars, on which it is afterward necessary to spend several times the original difference in first cost to keep the cars in condition to earn maximum revenue.

There are differing opinions regarding the use of structural and pressed steel in car construction, but it would seem that the advocates of structural steel are in the majority, and there is no doubt that repairs of foreign cars would be facilitated if, instead of so many pressed steel parts, structural steel were used. The writer has known cases where foreign cars have been kept on repair tracks for six months awaiting pressed steel material, whereas they could have been in revenue service in a short time if the parts had been of structural steel. It has been stated that rolled shapes cannot be had on account of the mills not having them in stock, but if the railways would make a more general use of this material and certain sizes and shapes of rolled steel could be decided upon by the Master Car Builders' Association, the demand would be increased and the mills would then arrange to have these sizes on hand. One of the large roads has adopted a design of box car having pressed steel posts and braces of U-shape section, and while this is the strongest design per unit of weight, yet if a number of these posts were torn off on a distant foreign road, it would be impossible to duplicate them and it would either be necessary to await shipment from the owner or car builder, or send the car home empty.

#### THE UNDERFRAME

There are numerous designs of steel underframe in existence, but it is generally agreed by the majority of railroad men that the fishbelly type of center sill is the most desirable, because there is a better distribution of metal and the stresses are more nearly uniform. Center sills should be built up of plates and angles, the webs being not less than 5/16 in. thick and the chord angles and cover plates of a size to suit the weight and capacity of the car. It is agreed that top cover plates should run the full length of the car, and some car men advocate bottom cover plates; but these are not necessary if bottom chord angles of proper size are used. Others advocate center sills continuous to the end of the car, but it is the practice of a number of large roads to splice Z-shaped draft sills to the center sills ahead of the bolsters, and this design is giving satisfactory service.

The side sills are also of numerous shapes, some being fishbelly, others straight pressed sections and others rolled sections. Here again a straight rolled section is advantageous, as it permits of a close inspection of brake rigging, especially on long trains at terminals where there are short stops and a limited number of car inspectors. If cross bearers and bolsters are of ample strength the rolled side sill need only be strong enough to take care of the load between these lateral members. Side sills should also be high enough above the rail to permit complete opening of the journal box lids.

End sills can also be built up of rolled sections to advantage. The bolsters and deep cross bearers, however, can with advantage be of pressed section, and if these parts should be standardized all railway repair shops would probably in a short time be equipped with dies for straightening them, so that there would be little difficulty in repairing steel underframes.

Some designs of underframes make use of crossties or needle beams which pass through the center sills, but in order to get these out in case of repairs it is necessary that the side sills be set on top of them. This is not good construction, as a derailment would bend them out of shape, whereas if they are set flush with the side sill at the bottom and a fishbelly center sill is used the car can skid along with the least damage to the underframe. Cross bearers should preferably be as deep inside as the center sills, have ample top and bottom cover plates, and substantial fillers between the center sills. The underframe and body as a whole should not be so rigid that it will not take low joints at diagonally opposite corners, as this will cause derailments.

Center plates should be backed up with substantial steel castings riveted between the center sills and substantial steel buffer

\*Entered in the Car Department competition which closed February 1, 1914.

castings used. These castings should not be too light, a thickness of  $\frac{5}{8}$  in. being about the minimum, as  $\frac{1}{2}$  in. cast steel, when pouring, will congeal before entirely filling the mold if the heat is not exactly right and imperfect castings are the result. Center plates should be lipped over the bolster bottom cover plate to help take the shear off the rivets.

In designing the car generally, care should be taken to see that no part which is apt to require frequent attention or repairs is overlapped by some other part as this condition may more than double the cost of making the repairs.

With a center sill cover plate running from end to end of the car it would seem that the diagonal braces should be run from the corners to the intersection of the center sills and bolster instead of from the end sill at the center to the bolster at the side sills. More benefit will be gained from the braces in this position. Moreover, draft and center sills should be made stiff enough to resist all buffing shocks without transmitting any of the force to the side sills.

BOX AND OTHER HOUSE CARS

The outside metal frame type of box car, with Z-bar posts and braces and single inside lining, has fast come into favor in the

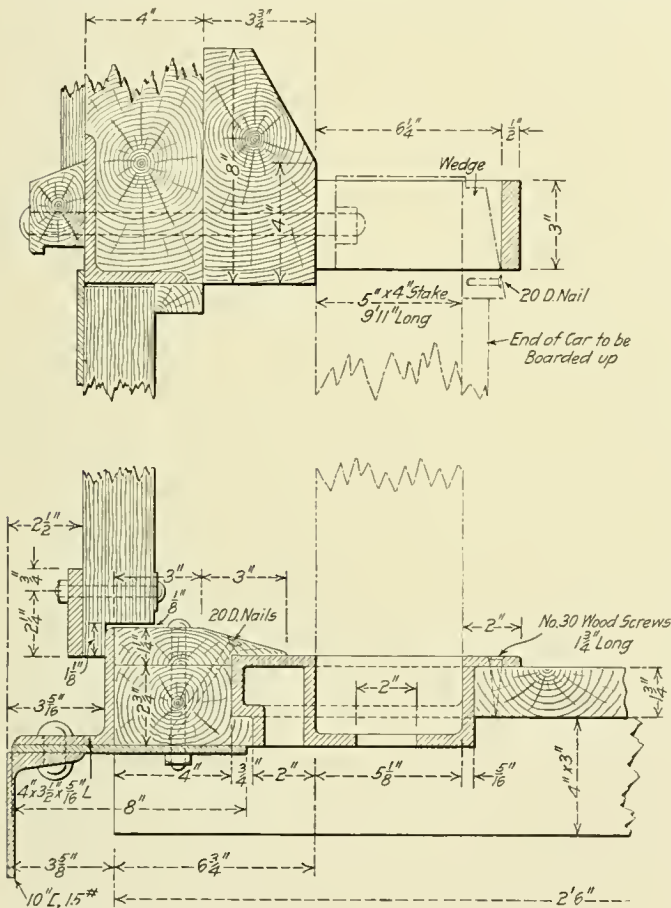

Temporary End Reinforcement for Automobile Cars

past few years among a large number of railways and presents many advantages. The side posts and braces should preferably be attached to the narrow side sills through ample gusset plates to give them sufficient rivet bearing area, which will prevent the loosening at the side sill which has occurred on some cars without such plates. In some cases no bracing is used on the ends and apparently with good results, but better results can be obtained if a plate be run across the end of the car at the bottom, riveted to the top flange of the end sill and extended up for 15 in. to 18 in., and the end posts riveted to it. This allows one end post to be used as an inside end ladder rail, and also makes the brace from the bolster to the upper corner of the car

unnecessary, as it carries the corner load over to the center sills.

The end doors of automobile cars are a continual source of trouble end expense, and it would be to the interest of all roads if they could arrange an agreement with automobile manufacturers whereby the end doors could be dispensed with and the double side doors used. The end doors not only get out of shape, but where it is desired to make a return shipment of bulk freight in an automobile car, it is necessary to supply a temporary end to protect the doors or the car will have to be returned empty. Of course if most of these cars are kept in the automobile manufacturing district they can usually be loaded, but if sent into an agricultural or lumber district, it is not safe to load them for return movement unless the end doors are protected. As this is expensive for the shipper, the car often returns empty. A method of protecting the end doors of automobile cars is shown in the illustration.

Large end doors have not been made satisfactorily water tight, and the writer believes that only small end doors should be applied, and these in all box cars, as they can be made water tight and will permit the loading of long lumber and similar material. Automobile cars would then become revenue earners in both directions.

The writer believes the outside metal roof to be the most satisfactory of the three types in general use. Some car men advocate the inside roof, claiming that the outside roof boards protect the metal and that it is impossible to keep the outside metal painted, resulting in its rusting out rapidly. They seem to forget, however, that it is impossible to keep the outside boards in such a condition that they will not permit water to leak through to the inside metal and corrode it, with no chance of detecting the leak from the outside. The outside metal roof can be kept painted, and if properly galvanized and provided with sufficient movement between the sheets should give the least trouble. At the same time the roof boards act as an insulator.

The all metal roof shows evidence of sweating on the inside when no ventilation is provided. However, this sweating will be reduced when the roof is ventilated, but there is still a question as to whether ventilation will entirely eliminate this feature which damages lading. The roof sheets should provide ample movement to accommodate the distortion of the car body when running over low joints, especially when loaded, and to provide for the end shocks which are always transmitted to the roof; the roof tends to remain stable, while the underframe is being moved by the shock. It is desirable to cover the roof boards with a layer of burlap soaked in a good tar, or lead paint, and apply the metal roof on top of this. It is also good practice to apply a layer of good waterproof tarred paper under the running board saddles, as this will prevent possible leakage.

DOORS

The question of making the side doors waterproof is one of next importance to the roof and with the use of the most improved types of fixtures the danger of leakage is reduced to a minimum. Some roads are using all metal side doors, but the least kink will make these inoperative, whereas the wooden door is resilient and will usually return to its normal position after a moderate shock.

One of the greatest causes of damaged doors is the fact that empty box cars never have the doors fastened, which allows them to shift to and fro under the movement of the car. If an open door lock or catch of substantial design were used and the door fastened when in an open position, a great deal of this damage to doors would be overcome, provided, of course, the men handling the cars would give this matter careful attention.

DRAFT GEAR

The most important detail affecting all types of cars is the draft gear. The friction type is now the recognized standard, as it absorbs a greater percentage of the shock than the spring



gear, with the least amount of recoil, consequently the minimum shock is transmitted direct to the center sills. Some large roads are using spring gear, apparently with good results; however, one road in keeping a record of failures of both spring and friction gears during a period of six months found the spring gear failures amounted to 81 per cent, while friction gears showed only 17 per cent.

Draft lugs should be of cast steel and of substantial design, with the front lugs arranged as a stop when the gear is solid. This will distribute the final shock over a larger area of the draft sill; if the key type of gear is used, a back stop is preferable.

Where the gear is of a type having springs on both sides of the transom, it is preferable to have a greater capacity for buffing than for pulling, but easy side movement of the coupler must not be overlooked. A flexible coupler centering device is a desirable feature and coupler side clearance should be such as to reduce lateral strains on the car body to a minimum.

#### TRUCKS

The Master Car Builders' Association already has a number of standards for trucks, but additional standards are desirable, such as the height of truck center plates and body side bearings from the rail, so as to make trucks interchangeable for cars of the same capacity. It is also believed that the standard M. C. B. center plate could be improved, as it has developed weaknesses. Center plates should be separate and be lipped over the bolsters, and side bearings should be adjustable to provide proper side bearing clearance at all times. Another important feature is the spacing of the side bearings from the truck center, which should be such that the car body will not tend to topple off the trucks nor to lift the trucks from the rail. A satisfactory spacing is about 25 in. from the center pin. Standard arrangements of brake rigging are also desirable. Bolster and column, or cast steel side frame fits should be standardized also, both as to vertical and horizontal dimensions, and trucks should be assembled in jigs to insure squareness, so all wheel flanges will wear evenly.

Lateral motion devices are being used by a number of large railways, and tests have shown that the resistance of trains is less when they are used, indicating a reduction in flange and

rail wear. The lateral motion should not exceed 1 in. to 1½ in. on each side.

#### PAINTING

In general the steel underframe joints should have a good heavy coat of red lead put on with a stiff brush before assembling and the underframe should preferably have three coats of paint. Some car builders only give two and others go so far as to say one is sufficient. In applying three coats it is well to use a metallic brown for the first coat with a second coat of a darker brown, and the third an approved black. This color scheme will insure inspectors that all three coats are being applied. One coat of good truck black is usually sufficient for the trucks.

### DAIRY REFRIGERATOR CAR

The Merchants Despatch Transportation Company, which is now controlled by the New York Central, has amongst its latest equipment some well designed and carefully constructed dairy cars. These cars are insulated with four courses of ½ in. Flax-linum, and are provided with the Bettendorf steel underframe and trucks. They weigh 55,000 lb., and have a capacity of 80,000 lb. The superstructure is entirely of wood with the exception of the Murphy steel roof, which is applied over a 13/16 in. roof of yellow pine. The car is 40 ft. 5 in. long and has a capacity of 2,062 cu. ft.

The superstructure being entirely of wood must be specially substantial to successfully withstand the shocks and strains received in service without injuring the insulating properties of the car. Extra care is required in this respect, as this type of car is so heavy. From a study of the car it is believed that these conditions have been adequately met. The end sills are 6 in. by 4 in. oak beams mortised for the end posts and tank cripples, and secured to Z-bar and angle iron reinforcements by ⅝ in. bolts. The side sills are 5½ in. by 4⅜ in. long leaf yellow pine, and are secured to Z-bar side sills with ⅝ in. bolts. There are six 4 in. by 4 in. intermediate sills of long leaf yellow pine which are secured to the cross ties and bolster members by ⅝ in. bolts.

The bottom course of the flooring is 1¾ in. thick and extends



Refrigerator Car for Merchants Despatch Dairy Line





outside sheathing is nailed to these nailing strips. A side sill board is applied at the bottom edge of the side sill which forms a guide and rest for the insulation. The lower edge of this layer of Flaxlinum is waterproofed to a height of 8 in. The inside of the car frame is covered with a layer of 2½ ply waterproof P. & B. Giant paper which extends from the top of the 1¾ in. flooring to the side plate. Three layers of Flaxlinum are then applied with a layer of the waterproof paper between them. The inside course of Flaxlinum is waterproof to a height of 6 in. above the top of the floor. These three courses of insulation are secured by nailing strips at the side plate and the floor and at the posts. The inside lining is nailed directly to these nailing strips.

The underframe is insulated by two 1 in. layers of Flaxlinum composed of two courses each. The bottom layer is applied directly on top of the 13/16 in. insulation, which is held in place by nailing strips 1 in. square. This layer extends only between the intermediate car sills. An air space is provided between the bottom and upper layer. A second course of wooden insulation extends between the intermediate sills and is flush with the top of them. On top of this is applied the two courses of Flaxlinum, which extend the full width and length of the car in one piece, with courses of waterproof paper between them. On top of the top layer of Flaxlinum is applied a coat of Hydrex compound to thoroughly protect the insulation from moisture that may possibly leak through the floor. Another air space is provided between the top layer of Flaxlinum and the 1¾ in. flooring.

The roof of the car is insulated by four layers of Flaxlinum, the three upper layers of which extend between the carlines for the full width of the car. The bottom layer extends across the full width of the car and for the full length, underneath the carlines, in one continuous piece. Above and below this layer is applied three-ply P & G waterproof paper. This layer of insulation is held in place by nailing strips nailed directly to the carlines. The ceiling proper is nailed directly to these strips. The second course of insulation is applied directly on top of the lower course, being held in position between the carlines by nailing strips. An air space is then provided between this layer and the wooden insulation, which is 13/16 in. thick. On top of this wooden insulation is applied the other two layers of Flaxlinum, waterproof paper being applied between each layer. The roof is applied directly on top of the carlines, as shown in the drawing. On top of this is a layer of burlap plastic, on top of which is applied the Murphy steel roof.

The following are the general dimensions of the car:

Length outside of sheathing.....	41 ft. 6¾ in.
Length over end sills.....	41 ft. 4¾ in.
Length inside of lining.....	40 ft. 4¾ in.
Distance between ice tanks.....	33 ft.
Width over outside sheathing.....	9 ft. 5¾ in.
Width inside of lining.....	8 ft. 3¾ in.
Height of running board from rail.....	12 ft. 11½ in.
Cubic capacity.....	2,062 cu. ft.
Capacity.....	80,000 lb.
Light weight.....	55,000 lb.

CONDUCTIVITY OF LOCOMOTIVE EXHAUSTS.—The results of investigations of the electrical conductivity of the exhaust from steam locomotive stacks have recently been published showing why discharges from high-voltage trolley wires to locomotive stacks can occur through distances much less than usual when gases and vapor are escaping from the latter. Experiments show that the greater conductivity under these conditions is due to the ionization occurring in the space between the wire and the track, produced by the friction of the escaping gases and moisture. Experiments were made with a locomotive under a wire and with its blower closed, half open, and wide open. The breakdown voltages between wire and stack were compared with those required to break down the same length of air path with the locomotive removed. On the average it required about one-half the voltage to break down the air with the locomotive present.—*The Engineer*.

## REFLECTOR FOR OBSERVATION CAR WINDOWS

BY R. S. LOWDER

A reflector somewhat similar to the type used on automobiles has been applied to the observation end of a private car recently built by the Pullman Company.

The reflectors, one of which is applied to each rear observation room window, enable the occupants to see ahead of the train by glancing out of the side windows. They are so arranged that they can be quickly folded against the side of the car when so desired. The location on the car is shown in the accompanying illustration.

The reflector consists of a plate glass mirror set in a metal frame on which are cast lugs turning in brackets fastened on the side of the car. The mirror frame in service position is held at right angles to the window by a brace riveted to the side of the car. The brace is slotted to take a pin attached



Reflector for Car Window

to the outside edge of the mirror frame. A simple spring latch attached to the end of the brace locks the pin in the end of the slot, and holds the mirror securely in service position.

When it is desired to fold back the mirror the occupant of the observation room, by reaching out of the window and pressing outward on the projecting end of the spring latch, can disengage the pin, which is then free to move back through the slot. The mirror can then be folded back until it snaps into the spring clip on the side of the car.

To place the mirror in position it is only necessary to push outward on the end of the brace which, acting as a lever about its pivot, will disengage the frame from the clip and swing it outward until it comes within reach. It can then be pulled forward until locked in position by the spring latch.

POWER IN THE UNITED KINGDOM.—At a recent meeting of the Manchester (England) Association of Engineers, Edward G. Hillier stated that the total horse power in use in the United Kingdom was 10,578,475, nine-tenths of which was provided by steam engines. Steam turbines rated second in the list, gas engines third, and water power fourth.—*Power*.

# SHOP PRACTICE

## PLANT FOR REPAIRING BOILER TUBES

BY R. C. POWERS

The Baltimore & Ohio has installed at the Mt. Clare shops a plant for repairing locomotive boiler tubes. The accompanying engraving will give an idea of the layout as well as the process of handling.

The plant was designed to keep up with the demands of the 60 or 70 boilers per month going through the shops, and several small outlying stations. Prior to the construction of this plant the work was divided between the boiler and the smith shops, the former repairing the tubes for Mt. Clare and the latter for the outlying stations. But with the increasing demand for space in the boiler and smith shops, together with the advent of the 5½ in. tubes for superheater locomotives, it became necessary to construct a new plant. It was then decided to concentrate all tube work at Mt. Clare. Not being able to construct the plant in or adjoining the boiler shop because of lack of space, the present location, which is about 800 ft. west of the erecting shop, was decided upon.

The old tubes when removed from the boiler are put on a rack so that they may be transferred by a crane to one of the

heated in furnace No. 2 and scarfed on tool No. 3, the safe ends are applied and the tubes put in furnace No. 2 for a welding heat. After welding to the approximate length and shouldering on machine No. 4 or No. 5, as desired, they are placed on rack E. From this rack the tubes are taken and cut to the exact length with cutter No. 6 by means of gage No. 7, and then placed on incline rack F with the ends in furnace No. 8. When the desired heat is obtained the ends are expanded on machine No. 9 and the tubes then placed on a truck.

A hydrostatic test is made on machine No. 10 as the tubes are taken from the truck and placed on another. When the required number of tubes is obtained for a locomotive, the truck is pushed out to the crane, and by it the tubes are put on a standard gage truck and returned to the erecting shop. Section A is fitted to repair tubes of any diameter between 1¾ in. and 5½ in. by adjusting or changing tools. Sections B and C are used for tubes 1¾ in. to 2½ in. in diameter; the three sections are the same except that the Hartz rotary welding machine and additional dies are used in section A on the large tubes. The tubes are usually kept in sets as removed from the boilers on account of the different lengths. When tubes are received from outlying station they are handled by the crane as above.

The building is 45 ft. by 180 ft. with a depth of 20 ft. under

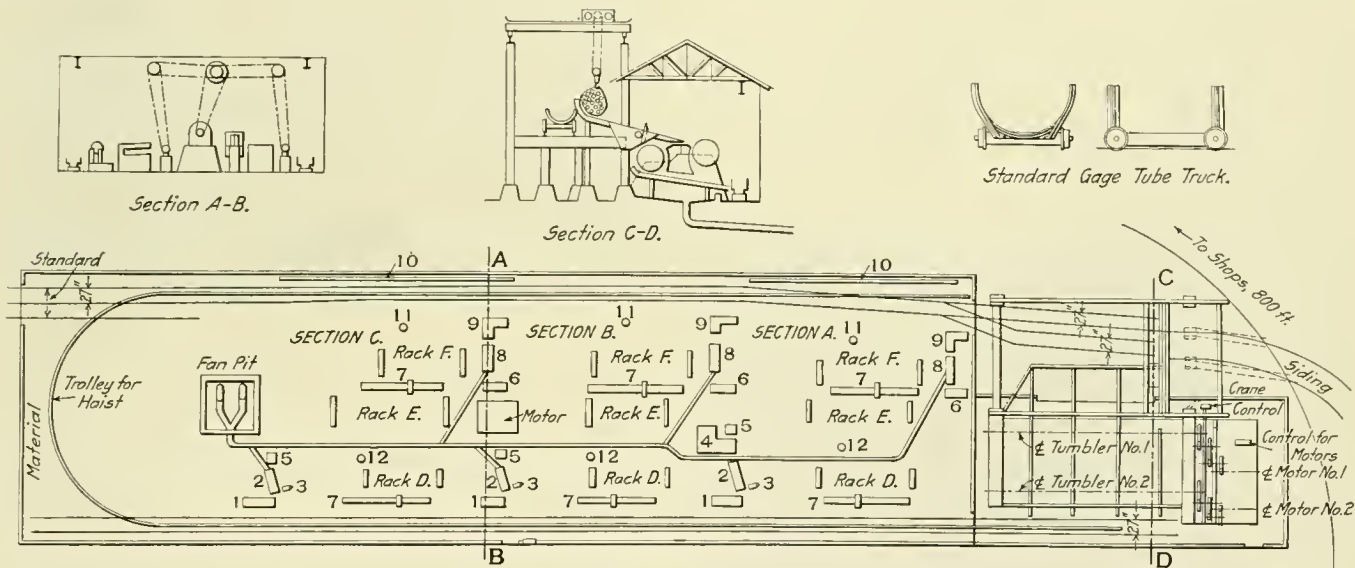

Baltimore & Ohio Boiler Tube Repair Shop; the Curved Line at the Right Represents a Bulkhead Supporting the Tracks

standard gage trucks on which they are taken to the stub switch siding in the tube plant. This siding is about 12 ft. above the floor of the plant. The tubes are taken from the truck by means of a crane and placed on the runway over the tumblers. This runway is built of 1 in. by 4 in. iron placed on edge, supported by a 12 in. I beam over the tumblers and braced with ½ in. plates. The outer end of each piece is supported by a 4 in. I beam placed on end in concrete. A stop or gate is provided to regulate the number of tubes going into the tumbler, and there is also a guide to direct the tubes into the desired tumbler.

The tumblers are of the type in general use, being driven by a 35 h. p. electric motor through a chain of gears, and elevated to allow the tubes to drop out to a runway which delivers them to a 27 in. gage truck. The truck is then pulled into the repair section.

Tubes are taken from the truck, the ends are cut off by cutter No. 1, and they are then placed on rack D. They are next

the bottom chord of the roof truss. It is of wood construction and is covered with sheet iron over 1 in. sheathing. The foundations for the building and all the machines are of concrete, as are also the basins under the tumblers, these being fitted with a drain pipe. Large windows have been provided to give plenty of natural light. Fine stone screenings were used as a floor. The following equipment is installed:

- 1 10 ton electric crane.
- 2 28 ft. by 48 in. diameter (inside) tumbling barrels for cleaning (used with water).
- 3 cutting off machines (No. 1).
- 3 furnaces (No. 2) for welding and shouldering.
- 3 tools for scarfing ends before welding (No. 3).
- 3 McGrath pneumatic hammers (No. 4) for welding and shouldering. (See July, 1912, American Engineer, p. 357.)
- 1 Hartz rotary welding machine (No. 5) driven by an electric motor (used for 5½ in. tubes).
- 3 cutting off machines (No. 6).
- 3 inclining furnaces (No. 8) with rack F.



- 6 cutting off guides and gages (No. 7).
- 3 pneumatic expanders (No. 9).
- 2 boiler tube testing machines (No. 10) (shown on page 484 in the September 1912 issue of the American Engineer).
- 3 portable tube rests (No. 11) fitted with rollers for one tube.
- 3 portable tube rests (No. 12) fitted with rollers for three tubes.
- 2 No. 5 Sturtevant blast fans in pit 9 ft. by 9 ft. by 3 ft. deep.

The plant is piped for cold water, air and crude or fuel oil at 100 lb. per sq. in. The crude oil is used in the furnaces. A 27 in. gage track extends the full length of the shop on each side for the use of the small tube trucks. A 15 in. I beam extending the full length and connected at one end is used as a trolley for a 4-ton Sprague hoist. The motors, crane and hoist are of the 500 volt direct current type in general use.

Artificial light is obtained from twelve 250 watt multiple burning tungsten lamps on 110 volts. The fan pit, and all machines having belts, are protected by guards built of pipe. Sufficient heat is obtained from the furnaces without any heating system. All the machines and tools, except the fans, motors, hammers and hoist, were made by the shop forces at Mt. Clare.

The truck illustrated is one of the standard gage tube trucks used to take the tubes from the boiler shop to the tube plant and return. The 27 in. gage truck is of similar design, each having 12 in. wheels fitted with roller bearings. The frame is of 2 in. angles, with 2½ in. by 4 in. steel for the axles. There is also a standard gage track entering the shop at the north end which can be used in case of emergency. This track connects with the east end of the boiler shop, which is about 2,000 ft. away.

## VACUUM LIFTING DEVICE

For some time the Westinghouse Electric & Manufacturing Company, East Pittsburgh, Pa., tried mechanical safety devices of various kinds for the punch shop, but with unsatisfactory results. The operators found them unsuited because of the fact that they tended to retard the production and consequently their earnings, while the management also objected to them because they afforded only partial protection,

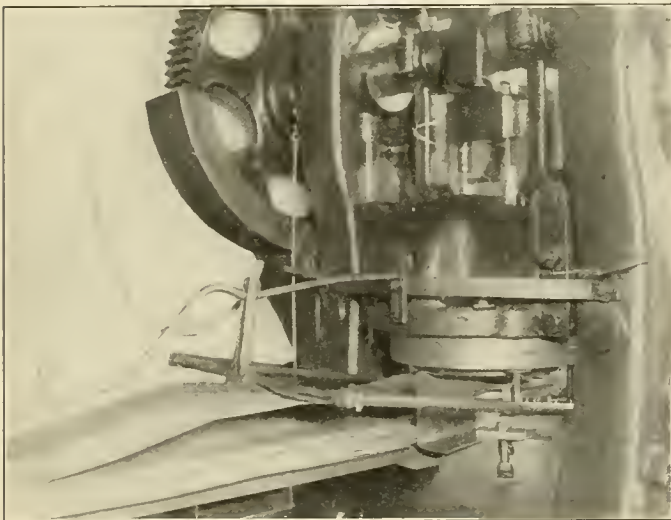

Safety Suction Device Used on Punch Presses

as the operator had to place his hand under the press in every instance, in order to remove the scrap.

The vacuum lifting device shown in the illustrations enables the operator of a punch press to dispense with the helper, and at the same time all danger to the hands is removed. This consists of a "sucker" or lifting device about 8 in. in diameter, which is connected by means of a rubber hose to a suitable suction line and which is further free to move on an irregularly shaped rod, its length of travel being controlled

by the press hand through the medium of two guide arms or handles, one on either side of the punch and die; that is, just inside of the press housings.

When a pile of metal sheets is placed in the rear of the press preparatory to being punched, the press hand on the opposite side of the press pushes the guide arms through the press towards the pile. The irregularly shaped rod allows the "sucker" to drop until it rests on the top sheet of the pile, when a lever on one of the two guide arms is pressed, thus opening the suction valve and causing the "sucker" to grip the sheet. The guide arms and the suction lever are not released until after the first blank has been punched. By thus retaining hold of the guide arms, practically all danger



A Hand Adaptation of the Safety Suction Device

of injury to the hands is removed, for in punching the succeeding blanks, the operator can almost invariably pull the sheet forward by means of the scrap or margin.

Since the adoption of this suction device there has not been an amputation on the large presses and up to the present no fingers have been amputated in the punch shop. The device was exhibited and received the grand prize at the recent International Exposition of Safety and Sanitation in New York City and is now on exhibition in the American Museum of Safety there.

**SMOKE PREVENTION SCHEMES.**—That the smoke difficulty with steam locomotives is a real one may be at once admitted; but that the solution lies in distributing the smoke behind or under the train cannot be accepted. Yet, from the earliest days of the steam locomotive until now, inventors have proposed all sorts of ideas of this kind. One of the most ingenious was tried years ago on the Metropolitan Railway. Between the rails a trough was laid, and the engine carried a sliding shoe device adapted to slide over this, and to open doors as it passed, whereby smoke led from the stack to the shoe was enabled to pass into the trough, thence being exhausted to a collecting plant. Other ideas consisted of extension stacks leading to the back of the train. And now another scheme of the same class is presented in which a smoke conveyor extends from the stack to a point at one side of the engine and near the rear driving wheel.—*The Engineer.*

# MASTER BOILER MAKERS' CONVENTION

Eighth Annual Meeting, Held in Philadelphia; Addresses by Ivy L. Lee, S. G. Thomson and Frank McManamy

The eighth annual convention of the Master Boiler Makers' Association was held at the Hotel Walton, Philadelphia, May 25-28. The first session was called to order at 2:30 p. m. on Monday, May 25, by the president, T. W. Lowe, general boiler inspector of the Canadian Pacific, and was devoted to addresses by Rudolph Blankenburg, mayor of Philadelphia; S. M. Vauclain, of the Baldwin Locomotive Works; Ivy L. Lee, chief executive assistant to the president of the Pennsylvania Railroad, and by the president of the association.

## MR. VAUCLAIN'S ADDRESS

Mr. Vauclain called attention to the fact that it is the care and maintenance of a boiler that exacts the greatest amount of attention and skill. It is a comparatively simple matter for a builder to construct a boiler in accordance with designs that have been prepared, and if he is honest and wishes to turn out good and reliable work it can be done; for the men in a shop are apt to be infused with the spirit of the employer. He insisted that the best of men were required for repairs and called attention to the difficulty of getting them. Young men do not take kindly to the boiler shop, but, in his opinion, that department is one of the most, if not the most important of the works. For that reason he advises all of his apprentices to spend a part, at least, of their apprenticeship in the boiler shop, because skill in that line promises better for promotion than any other. He considered that the work on the boiler required more skill than any other part of the locomotive, because of the nature of the material that is used and the necessity of being familiar with its every aspect, such as it flanging and bending qualities, in order that it may be rolled and bent into shape without injury. It also requires a high degree of technical skill in order that the foreman in the shop may be able to check and detect any inaccuracies that may be made in the drawings, for inaccuracies will creep in in spite of everything that may be done. It is this knowledge and technical skill on the part of the boiler maker that is necessary to avoid disaster both in the building and the repair shops.

It might be thought that the building of boilers was one long piece of routine work, but it is nothing of the sort. Each boiler presents new and individual problems that only the practical and skilled man in charge can solve, so that it is safe to say that the greatest amount of skill is required in order to become a successful boiler maker.

In replying to Mr. Vauclain, C. P. Patrick called attention to the great lack of boiler maker apprentices and urged the recruiting of their ranks in order that there might be a supply for the future. He also spoke of the work of the federal boiler inspectors and said that, when the law was first put in action, he regarded many of its provisions as unnecessary and as putting a hardship on the railroads. But after an experience with it of three years he had come to the conclusion that it was a good thing and had found that when a road was willing to meet the inspectors and show that it was endeavoring to do its best and keep its boilers in a good state of repair no difficulty was encountered.

## IVY L. LEE'S ADDRESS

Mr. Lee spoke on the safety first question and said that it warrants a certain amount of money being spent in order that economical results might be obtained. There is a limit, however, beyond which it will not be worth while to spend money, as the results that can be obtained will not be commensurate with the cost. It is sometimes far better to turn to the improvement of the men than to the improvement of

the physical features of the road. In other words, it is well to turn attention to man failures. In England, where human life is placed on probably a higher value than in any other country of the world, and where their cars are little better than wooden handboxes, there has been no indication of a movement towards the compulsory use of the steel car, because they think more of discipline than they do of such helps to minimize the effects of an accident. We have gone further. There is a movement on foot to legislate expenses upon railroads that they cannot properly bear. The carelessness of automobile drivers, for example, causes one long continuous series of accidents at grade crossings, a series of accidents that spell carelessness on the part of the drivers of those machines and which would never happen if they would use ordinary care. Yet the state of New Jersey has enacted a law for the abolishing of grade crossings that puts the whole burden on the railroads. Yet to abolish the grade crossings in New Jersey on the Pennsylvania Railroad alone, would cost about \$60,000,000. To abolish all the grade crossings on the whole Pennsylvania system would cost about \$600,000,000 and to do the same for all of the crossings in the country would cost about \$5,000,000,000. So that the cost of such provisions for safety becomes simply stupendous, while it could all be avoided by the exercise of common carefulness.

The same statement holds in the matter of trespassers. Here, again, it is simply a case of carelessness. Trespassers are killed and it is man or woman carelessness.

The Pennsylvania Railroad has spent immense sums for the promotion and securing of safety, but it must be evident that there are limits beyond which it will not pay to carry the expenditures. It is far better to cultivate the spirit of carefulness. Take the matter of the automatic stop, for instance. Suppose such a stop were available and could be used. It would simply be transferring the responsibility from the man on the engine who has the interest of his own life to make him careful, to the shoulders of another who has no such interest. Again, the self-cleaning ashpan that has been required by law. It has cost the Pennsylvania Railroad alone about \$600,000, and all of this is an absolute waste and would not have been needed, if the men were careful.

In the matter of boiler construction the Interstate Commerce Commission contemplates the establishment of an arbitrary factor of safety. If this is done we will be the only country in the world where such a rule exists for other than state railroad. Such a rule, if made calling for a factor of safety of 5, would not add materially to the exemption of locomotive boilers from explosion. Out of the 63,000 locomotive boilers in use in this country there have been but six shell explosions in two years, making an average of one shell explosion for each 21,000 boilers per annum, and this on a factor of safety of about  $3\frac{3}{4}$ . While on the Pennsylvania Railroad there has not been a single shell explosion since 1880. The whole question of boiler safety sifts itself down to one of carefulness and maintenance. Take the reports of the Travelers Boiler Insurance Co. Out of all of the money collected for insurance 25 per cent was spent in securing business; 50 per cent for inspection; 10 per cent for business expenses; 5 per cent for profit and 10 per cent for loss. So that out of all the money paid for steam boiler insurance, 90 per cent was unnecessary, and could have been saved by carefulness.

In short, it is a question of men. It points to the necessity of taking young men and training them so that they will appreciate the necessity of being careful; of showing them



that pure mechanical and mathematical formulae are not altogether reliable and dependable, but that back of their use there is need of experience and care, and this training is of the first importance if satisfactory results are to be obtained. The perfection of the man as well as of the machine is what we must work for.

The morning session on Tuesday was opened with addresses by S. G. Thomson, superintendent of motive power and rolling equipment of the Philadelphia & Reading, and Frank McManamy, chief of the boiler inspection department of the Interstate Commerce Commission.

#### MR. THOMSON'S ADDRESS

Mr. Thomson especially emphasized the value of and the assistance to be derived from the federal boiler inspectors. These men are all experienced and their duties, in taking them from one road to another, give them opportunities for observation that do not come to the average boilermaker. They are, therefore, possessed of a mass of information that they are quite ready to impart and which the members should take every opportunity to acquire. It behooves every boilermaker in the country to welcome these men to their shops and learn what they can from them. There can be no quarrel with the boiler inspection law if an attempt is made to comply with its provisions and get all out of it that is possible.

He also touched on the difficulty of getting good men to do the work and the scarcity of apprentices in the boiler shop. It is hard and noisy work and needs ample compensation, both physical and mental. The former must come through the wages received and the latter from the satisfaction of work well done.

#### MR. McMANAMY'S ADDRESS

Mr. McManamy took exception to a statement that had been made by Mr. Lee to the effect that it was possible to spend too much money for the prevention of accidents, and insisted that resources could not be wasted in an attempt to secure greater safety. While many accidents might be due to man failure, and all boiler failures might be attributed to that cause, yet, if that were the case, then the application of the boiler inspection law had succeeded in reducing man failures by about 60 per cent in the fatalities due to boiler accidents in comparison with what had occurred before the law became effective. Thus for the first year of its operation and for the following nine months for which reports are available the reduction has been 48 per cent. If the application of the law has been responsible for the elimination of a single accident that caused a loss of life, it is well worth while.

All that the federal boiler inspectors ask is co-operation on the part of the boilermakers and others who are responsible for the operation of boilers on railroads. It must be remembered that the government does not supply the inspectors that are to do the everyday work of inspection. That is done by the employees of the railroads, who thus become the real government inspectors.

As for the factor of safety, the roads have been working under a factor of safety of 4 for some time, and the manner in which it is proposed to enforce a strict compliance with this factor will bring no hardship to any one. In the early inspection of boilers, it was found that there was a large number of them that had a very low factor. In fact, some were found whose factor was below two, and surely no boilermaker would advocate running a boiler in that condition. While there may be some difference of opinion as to what might be the best factor to employ, no one would hazard the opinion that 2 was correct to use. In the early inspection referred to it was found that there were:

212	boilers whose factor of safety was less than	$2\frac{1}{2}$
1,224	boilers whose factor of safety was less than	3
2,371	boilers whose factor of safety was less than	$3\frac{1}{4}$
4,524	boilers whose factor of safety was less than	$3\frac{1}{2}$
7,254	boilers whose factor of safety was less than	$3\frac{3}{4}$
12,043	boilers whose factor of safety was less than	4

A factor of safety of 4 is not too high and the reason for fixing it at that is that it is one to which builders have been working for a number of years. Nor will it be any hardship to comply with the provisions of the rulings, for the railroads will have seven years in which to bring their boilers up to the standard. No road can possibly be tied up because of it. As it stands the regulation gives all roads up to January 1, 1915, to bring their boilers up to a point where the lowest factor of safety will be 3; until January 1, 1916, to bring them up to a factor of safety of  $3\frac{1}{2}$ ; until January 1, 1917, to bring them to  $3\frac{3}{4}$ ; until January 1, 1919, to bring them to  $3\frac{3}{4}$ , and until January 1, 1921, to bring them up to 4. That is a fair sample of the manner in which the department is attempting to co-operate with the railroads.

It is quite natural for men to resist the application of rules of regulation whether they be good or bad, even though those regulations really make no difference in their conduct. But it has been found that no big interest serves the public to the best advantage when it is uncontrolled.

Of late we have heard a great deal about the safety first movement. It is nothing new, for it started about 22 years ago, when it was enacted that the railroads should equip their cars with automatic couplers and air brakes. At that time some roads were using these appliances of their own accord, but it was necessary that legislation should step in to compel those who were not inclined to introduce these now necessary parts of the equipment to do so. Surely no one now thinks that the compulsory use of these things is a hardship, nor would any railroad man think that it would be possible to run his road without them.

In the same manner there will be no hardship in the enforcement of the regulation regarding the factor of safety. The railroads are not to be asked to make changes in a day that will require time, and boilers will be allowed to run until they are sent to the shop for the application of the firebox and wrapper sheet. So, too, it will be found that these rules are not new but merely the application of old rules that are already fixed and in use. When the matter was under discussion, the roads were asked to file copies of their rules, and it was found that out of the 170 roads complying with the request, practically every one of them returned the rules that have been adopted by the Master Mechanics' Association, so that these have become the basis of the federal rules.

Turning back to the boiler inspection rules, the records show that in the first year there were 856 accidents, in the second there were 820, and in the first nine months of the third year there have been but 523.

All the federal authorities ask is that there shall be a close and hearty co-operation between them and the railroads and, for the most part, this has been freely given.

#### SECRETARY-TREASURER'S REPORT

The secretary's report showed that during the past year \$1,211 was received for dues and from other sources; that there are 543 members, but that some of these are delinquents in the payment of dues, so that there are, today, 417 members in good standing. The treasurer reported a balance on hand of \$647.67 after the payment of all outstanding bills to date.

#### OXY-ACETYLENE AND ELECTRIC WELDING

The committee on oxy-acetylene and electric welding reported that oxy-acetylene welding seems to be satisfactory in results and in general use. Cracks in firebox sheets of all kinds have been welded with the acetylene process and some very good results have been obtained.

One report shows that cracks 15 in. to 30 in. long have been welded and have given eighteen months' service without trouble; also half side sheets have been successfully welded. Much trouble has resulted, however, from sheets cracking adjacent to the welds, or in the welds themselves, due to the unequal stresses placed upon the sheet when cooling. For

reinforcing thin places in sheets such as at washout hole openings, the oxy-acetylene process is of value. The process is serviceable in heating sheets for laying up, in the fitting of boiler work; also in straightening crown sheets where they have been damaged by low water, as the heat can be localized and thus not injure adjacent sheets. It has been found dangerous to make welds adjacent to riveted seams and staybolts, as both are prone to leak after such treatment when the boiler is again placed in service.

Oxy-acetylene has been found extremely valuable in cutting boiler sheets, engine frames, etc., and in some cases is used preparatory to welding. For use in emergencies, such as on wrecking trains where time is a big factor, it has proved its worth as a cutting agent. In the salvage of broken parts of rolling equipment and of shop machinery considerable savings are reported.

Electric welding is past the experimental stage. One very important point is that it is not dangerous.

Electricity has been used to some extent for cutting, but its greatest value is in welding. Cutting is done with a carbon, using it in the holder the same as the iron rod is used for welding. This method of cutting is not fast, but it can be used in places which are difficult of access with a pneumatic hammer.

Side sheets, half side sheets and patches on firebox sheets are successfully applied, using the welder in joining the sheets just as in a butt joint. Experience has shown that the more crooked the seam the more efficient is the weld, that is, the sheets should be cut in an irregular outline so that the weld will not be in a straight line. The same holds true regarding patches.

From various papers received by the committee the opinion in regard to the manner in which sheets should be fitted to make a good weld seems to be general. The best results have been obtained by placing the sheets about 3/16 in. apart and beveling them from the fireside about the same as a sheet is beveled for caulking. This allows the metal to burn through into the water space, filling the opening entirely. The welded seam should not be more than 1/16 in. thicker than the sheet which is welded. Reinforcing the sheet with welding metal is poor practice.

The welding of broken mud rings makes a saving and is done by cutting away the firebox sheet with the fractured mud ring. All the broken parts should be removed to give ample room for the welding. The welding should be done by filling in the opening, welding the firebox sheet and ring together.

Door opening flanges are repaired by setting in a patch, or in many cases applying a collar completely around the opening. This class of repairs is of great value, as in many cases the door opening flanges give trouble, when the remainder of the firebox is in good condition. A large number of door opening patches and collars are reported to have given good service for the past two or three years.

One of the most frequent questions asked in connection with electric welding is what success is obtained by welding over old seams that are damaged by fire, cracked sheets, and old patched seams also damaged. In most cases it is found that it is a very uncertain way of making repairs, as in many cases the weld fractures and continues to give trouble. There have been cases, however, where this kind of repairs have held fairly well. Very few cases of welded tube sheet bridges have given satisfactory service.

The best method in welding tubes in the tube sheet is to first apply the tube in the usual manner, viz., place a layer of metal around the caulking edge of the bead, being careful not to put it on too heavily, and hammer it while it is at a white heat. If proper care is taken in hammering this while at a white heat it will leave the metal smooth and will not require turning up. Tubes applied in this manner can be tightened in the sheet in case of leaks from the weld giving out by the ordinary method. In many cases the tubes have given double the mileage when welded in, and in all cases show a decided improvement.

Applying new ends to tubes by the electrical process is being experimented with at present and the results thus far obtained seem to be superior to those obtained by the former. The welding is very smooth and stands well under test. The miscellaneous uses of the electric welder are also numerous, such as repairs to shop machinery, etc.

The report was signed by Frank A. Griffin, chairman.

#### DISCUSSION

There was some confusion at first owing to misunderstandings regarding the methods to which the members referred. There was a mass of directly contradictory testimony as to the possibilities and the shop methods to be employed until it was required that each speaker should state whether he was talking of the electric or the oxy-acetylene method.

In the matter of the welding of tubes in the tube sheet, it developed that there had been considerable trouble with the tubes breaking just back of the weld, and in some cases small pieces had broken out, but had been welded in place again without removing the tube. This was especially apt to occur in bad water districts. The welding in of old tubes is not a profitable proceeding, and it is good practice not to weld in any tubes that are more than two or three years old. With new tubes no difficulty has been experienced. The usual method of applying tubes that are to be welded in place is to set them in the ordinary way and then cement them around the edges of the bead with the welder. The older method was to let the tube project through the sheet about 3/4 in., and then weld it in place. Some tubes have been applied without the insertion of the copper ferrule, but there has been trouble with them and it has been necessary to roll and expand them with great frequency, so that it is always better to use the ferrule.

The application of patches brought out a good deal of discussion, especially as to the best method of holding the sheets while the welding was being done. Two methods were proposed; one was to fit the sheet and lay it loosely in place and then weld, after which the rivets attaching it to the foundation ring or other part were to be driven and the staybolts put in. The other was to drive the rivets and insert the staybolts before the welding was done. When the patch was loosely applied, it was found necessary to drop one end by an amount proportional to the length of the patch and allow it to draw up as the welding proceeded. It was here that the difference of experiences came out. Some stated that it was impossible to put the tight sheet in place, and others that it was unnecessary to do it loosely. It finally came out that with the oxy-acetylene process it was necessary to use a loose sheet, while with the electric weld the sheet could be riveted in place first.

In the application of patches it was found that the oval patch was much more easy to make a success of than the rectangular patch, and that the round patch was better still. Cases were cited where oblong patches measuring 18 in. by 44 in. had been in service for more than a year with satisfactory results.

As for the welding of cracks a number of speakers stated that they had no success in welding cracks that were more than 12 in. long. Also it must not be expected that the welded crack will last as long or give as good service as the original sheet, and this holds especially where the patch is rectangular. The last side welded has to carry the greatest stress and is most likely to give way, and this is especially true where the weld is made with oxy-acetylene because of the greater heat developed and given out to the sheet and the consequent greater contraction of the welded part.

In the electric welder it was urged that a higher voltage than that usually employed should be used. In one case the first machine worked on a voltage of 250, the second had 500 and it is expected that the third will use 1,500 with greatly improved results.

Firedoors are welded in complete without the use of any rivets. This is done by simply laying the sheets in place and



welding along one edge of the lip of one of them. In this way a tight joint is obtained and one that does not require any calking. In some cases patches were made with a corrugation to take up the expansion with very satisfactory results. The welding of button head stays has been done so successfully that old worn stays have been made as strong as new stays.

Finally it was recommended that for welding the electric process worked the best, while for cutting the oxy-acetylene was much the better.

#### THE CHEMICAL TREATING OF FEED WATER

T. F. Powers, Chicago & North Western, reported in part as follows on this subject:

Feed water can be treated successfully, if systematized methods are adopted and wonderful results can be obtained, but otherwise it is a waste of money.

The cost of maintaining treating plants will, of course, vary according to the price of chemicals used, which are generally lime and soda-ash, these being the cheapest. There is no additional cost of labor, as the pumper can attend to the plant with his other duties.

Where treating plants are not installed, good results can be obtained by putting soda-ash into the tanks of locomotives. The amount per thousand gallons should be determined by the chemist, after an analysis has been made of the water; but in either case, the method of using must be systematic and the blow off cocks on locomotives used regularly. Blow off cocks should be so applied that they can be operated from either side of the cab by the enginemen without getting off the seat box.

One of the reasons soda ash has been condemned by some railroads is because the claim is made that it causes locomotives to foam and that it cuts out valves and packing. This is true if blow off cocks are not used. Soda ash is put into boiler to soften the scale or turn it into a sludge or soft mud. This should be removed through the blow off cocks. Their use will prevent foaming and tend to keep the boilers clean and extend the time between washouts, as it is the opinion of the writer that it is a detriment to the boiler to cool it down and that the longer the washout period can be extended, the better it is for the boiler. With the use of water from treating plants, or using soda ash direct into the tanks of locomotives, the washout period can be extended and the changing of water, in most cases, is unnecessary, provided the blow off cocks are used.

On the Chicago & North Western the locomotives are fitted with a blow off cock on each side, on the outside sheets near the front corner of the mud ring. Our instructions relative to the use of blow off cocks are to blow the engine into blow off tanks when leaving the roundhouse and to use the blow off cocks every few miles on the road, or at least once between every two stations. This is followed closely by the road foreman and master mechanics. The blow off cocks are also used on the arrival at the roundhouse. When blowing off on the road, the blow off cock is only opened from three to five seconds. This does not mean a great loss of water, as practically all that comes out in that time is mud. A good demonstration of this is to open the blow off cock on an engine that has no steam on, but with the water still hot. All that comes out of the cock for the first few seconds is mud, then clear water, showing that it is in the first few seconds that the mud is cleaned out. Another proof is to open a blow off cock against a snow bank or fence; it will be spotted in one place only.

On one 150 mile division of the Chicago & North Western using treated water, a few years ago it was necessary to either change water or wash the boiler at each end of the road. Now with the same water, engines are making 1,050 to 1,500 miles between washouts and are having no trouble on account of foaming. When plugs are removed there is not over 2 in. of mud on the mud ring. This improvement has been accomplished by systematic use of the blow off cocks, as described above.

Summing up the benefits derived from treating water with soda ash and lime in treating plants or putting soda ash direct into tanks when the blow off cocks are used, they are:

Failures from foaming are practically unknown; washout period is extended; changing of water is not necessary; better circulation is obtained, making better steaming engines; boilers are kept clean, and burnt and buckled side sheets are very rare; leaky tubes and side sheets are avoided; engines are run longer between shopping for tubes because scale is softened and removed by the blow off cocks in the form of mud; there is a decrease in the expense of upkeep in roundhouse, and a better feeling among men running engines, because engines are not failing on the road due to leaking and foaming.

H. W. Armshaw, Canadian Pacific, made the following report:

During the past 24 years the western lines of the Canadian Pacific have experimented with many different methods of water treatment. The chemicals used were principally lime, soda ash and caustic soda, and although all of them mixed with the water in various ways before entering the boiler, only one of them took care of the sludge.

This method consisted of agitating and settling chamber tanks, with means for removing sludge before the water entered the boiler. This was very satisfactory at times, and prevented heavy scale formation, providing sufficient caustic soda was used to take care of the majority of the sulphate of lime and magnesia, but when treated sufficiently to do this, the engines foamed so badly that we were obliged to resort to round trip washouts. When the quantity of caustic soda was reduced to alleviate foaming, a hard flinty scale developed around the tubes at the back tube sheet end and rosettes and stockings of scale accumulated around the staybolts, together with a formation of it on the firebox plates.

The life of tubes and firebox plates was lengthened over what was obtained with crude water, or with any other class of treatment, although it was not determined whether it was more profitable to renew the tubes and fireboxes at intervals to prevent boiler failures or treat the water as described.

During the past 18 months on the Saskatchewan division and for about one year on the Manitoba division, the treating of water by this means has been discontinued and a polarized metallic preparation substituted. The results of the application are, that it is possible to keep the boilers clean with sufficient and proper washing out, to run between general repairs without the removal of any tubes and without failures because of leakage. In no case has it necessitated more frequent washing out than with other methods of treatment. It has in all cases permitted 100 per cent more mileage between washouts and in many cases it is possible to run 200 per cent. So far as we have been able to discover, pitting or corrosion does not follow application of this treatment. It does not aggravate foaming. Its action on the removal of old scale and new formation appears to be more mechanical than chemical in that it does not create a pasty sludge next to the fire plates and tubes, which is common with other treatments and which prevents the water getting into proper contact with the plates, being most difficult to wash off, thus producing overheating of the plates and tubes, which frequently results in boiler failures.

By correctly regulating the period between washouts, with a strict observance of the best practices, accompanied by good water pressure, it is possible to do better than we have previously, inasmuch as the reduction in boiler maintenance and washing out expense has been greatly reduced, together with economy in water consumption, rubber hose, boots, etc., and less general wear and tear on the tool equipment for boiler washing and boilermaking. There is also a large saving in coal and lighting up material because of boilers being hot, due to less washing out, and also an increased earning power of the locomotive because it is available any time without boiler-washing or boilermaker's work.

Taking into consideration the many advantages, I feel quite satisfied in saying that it is more profitable from a mechanical standpoint than any other treatment experimented with during my experience. It is very conveniently applied after each washout, being distributed in bars over the crown and tubes, or arranged to suit what the inspection indicates to be the proper place to locate it, according to the condition and design of the boiler.

It is too early in our experience to say what percentage of saving is effected in boiler maintenance and boiler repairs because it takes several years to arrive at an intelligent estimate of its use compared with what was formerly obtained. However, my experience with it so far demonstrates that it is a great money saver.

#### DISCUSSION

The discussion was very meager and centered around the methods employed in the handling of the boiler where water treatment was used. The main thing that was insisted upon where soda ash is used is that the blow off cocks should be used with great frequency. On one road there is a blow off cock on each side of the engine that can be operated from cab and the men are obliged to use them either one for each mile run or at least once between stations. Where this rule has been observed there has not been a single case of a burned side sheet, and all difficulties with foaming has disappeared.

Some experience was cited with the different kinds of boiler compounds, but their success hinged to a great extent on the systematic use of the blow off. Polarized mercury came in for a good part of the discussion, and there was a difference of opinion as to its continued efficiency. In one case it was found that it cleaned the boiler of old scale and for a time thereafter seemed to work all right, when hard scale formed and it did not do as well as soda ash. In another case it had supplanted a series of water treating stations that extended over a whole bad water division, to the great saving of expense for the railroad. It does not attack the brass work and greatly reduces roundhouse expenses. In short, it has saved many thousands of dollars, besides doubling and trebling the mileage between washouts.

But when all is said, the success of any compound depends upon its applicability to the particular water that is used.

#### FLEXIBLE STAYBOLTS IN PLACE OF SLING STAYS

It was merely brought out that there is no advantage in their use insofar as the prevention of the cracking of the flange of the tube sheet is concerned, as the relief of the bending stresses to which that part is subjected does not seem to have any appreciable effect. The reason why they are used in that place is that they are so easy to apply.

#### COMBUSTION CHAMBERS IN LARGE LOCOMOTIVES

The committee reported that but few railroad companies are using boilers with a combustion chamber to any great extent. The Chicago, Milwaukee & St. Paul has 605 locomotives equipped with combustion chambers. These are of the Mallet, Mikado, Pacific and Prairie types, and are equipped with arch brick tubes.

The first of this class, a Prairie type freight engine, was put in service in 1907, which gives nearly seven years' experience, and should be ample time to demonstrate the benefits derived from a combustion chamber boiler or any weak points or faulty construction. The depth of these combustion chambers is from 32 in. in the Prairie type to 76 in. in the Mallet.

The Prairie type engines have tubes 13 ft. 4 in. long and 2 in. in diameter; the Pacific type tubes are 19 ft. long and 2 in. in diameter; the mikado type tubes are 17 ft. 7 in. long and 2 in. in diameter, and those of the Mallet type are 24 ft. long and 2½ in. in diameter.

The Prairie type engines have service records of more than

185,000 miles between tube settings, the Pacific type more than 196,000 miles, the mikado type more than 90,000 miles, and the Mallet type more than 86,000 miles.

There are 195 of the Prairie type, and during the past seven years these engines have been in service over most of the system. While a great many of them are in bad water districts, the tube records show over three years' service from the majority of the engines, and in many cases 50, 60 and 70 months' service. Twelve of these engines are still in service with the original tubes now having 60 months' service. In this class no new fireboxes have been applied except where damaged by low water. A number of side sheets, door sheets and back tube sheets have been applied, but only two inside throat sheets and one combustion chamber.

There has been but little trouble due to seams leaking. In some cases where there was trouble with seams leaking on top of the inside throat it was found necessary to scarf the sheet down and apply new rivets or bolts, but where this work had been done originally in a proper manner, the seams did not give much trouble on account of leaking.

The only trouble discovered at all was broken braces from the bottom of the combustion chamber to the bottom of the shell. It is believed that the cause is temperature strain.

The Pacific type engines are giving good service, the firebox sheets standing up well. A few side sheets and a number of back tube sheets have been applied. Over 36 months' service with one setting of tubes is being obtained and with but very little trouble on account of tubes leaking.

A few of the disadvantages of combustion chamber are increased cost of construction; breaking of throat stays; difficulty of removing broken staybolts from the bottom of the combustion chamber; the occasional leaking of seams on the inside throat sheets; the necessity of cleaning out the combustion chamber occasionally due to not keeping the bottom tubes open.

To offset this there are the following advantages: A good free steaming engine due to better circulation and more effective heating surface; less caulking of tubes, longer service as shown by the record, and less cold air striking the tubes; each renewal cost of tubes less on account of shorter tubes; increased life of back tube sheet due to less tube work; decreased cost of renewal of back tube sheet on account of smaller sheet, less labor to apply, no staybolts, no arch tubes, no mud ring; increased life of arch brick on account of not having to knock out the arch when renewing or working the tubes; due to increased combustion space above the fire, the combustion of the coal is improved and the smoke nuisance is greatly reduced; a combustion chamber boiler has a shorter flue, making a saving on the original cost. Fewer tubes are applied, making another saving, and a better tube sheet is obtained, due to wider bridges and better spacing, and therefore a better circulation.

The report was signed by A. N. Lucas, P. F. Gallagher and R. A. Pearson.

#### DISCUSSION

One of the advantages of the combustion chamber is that the tube sheet is very much more easily applied than in the case of the ordinary construction. Staybolts break in them, especially in the first row from the tube sheet, but this can be obviated by the use of the flexible bolt. It was also found that where the air pump was placed over the bolts they broke and when it was removed the breakage ceased. In oil burning service it is well to protect the seams with seam brick, and this can be obtained of any shapes to cover any part of the chamber that it is desired to protect. Tube failures are very much less with the combustion chamber than without it and there are records of a life of from 150,000 to 200,000 miles. There has been some trouble with the wings on the inside of the chamber, but this was attributed to the quality of the coal that was used and the fact that the seams were not protected with seam brick.



### RADIAL STAYS IN THE CROWN SHEETS OF OIL BURNING LOCOMOTIVES

The committee reported that the screw crown bolt and radial stay, with a taper of  $\frac{3}{4}$  in. in  $1\frac{1}{2}$  in. riveted over on the fire side of the sheets, give the best service. Where crown bars are used an extra heavy wrought iron pipe thimble should be used between the sheet and the crown bar. When radial stays are used they should be riveted over in the same manner as when crown bolts are used. Some roads are using a taper nut on the bottom end of radial stays over the crown sheet on coal burning engines. This is also thought to be beneficial on oil burning engines. The report was signed by C. L. Hempel, chairman.

### EFFECT OF THE METHOD OF FLUE CLEANING ON SCALING

The committee on this subject reported that if the flues are properly cleaned in a rattler, by a dry process, or are run in water, they will not scale up more readily than new flues. Experience indicates that when flues are properly cleaned in the rattler there is no material difference in the mileage obtained, nor in the amount of scale.

There are certain makes or designs of flue cleaners of the rotary type, which leave small crevices in the body of the flue, causing the scale to accumulate very rapidly, and flues cleaned in this manner accumulate the scale more rapidly, and accumulate a greater amount of scale, in the same length of time, than when they are new or cleaned by the rattling process. This kind of a machine does not clean the interior of the flue, which is very detrimental to it. The new or rattled flues are thoroughly clean on the inside.

This system of cleaning flues with a rattler does not cause them to scale after the application to the boiler, if they are thoroughly cleaned and the exterior left in a smooth condition.

Rough and improperly cleaned tubes cleaned by methods which leave the exterior rough and uncleaned and crevices in the body of the flue, will undoubtedly scale more readily in the boiler than new or smoothly cleaned ones.

The rolling of dirty tubes in a dry rattler, or in water rattlers, or on the chains of an ordinary rattler, seems to be the best form of cleaning, as it not only gives a smooth polished surface on the outside, but loosens and cleans out all the dirt from the interior of the flue. If the flues are properly cleaned in the above mentioned manner they will not scale any more rapidly than new ones, when the same kind of waters are used in the boilers. After all, the amount of scale accumulating on the flues depends almost entirely upon the amount of impurities or chemical properties contained in the water used.

If the flues are cleaned properly on the outside surface with a flue rattler either by the dry process or in the water and the replaced or pieced flues are free from scale and as smooth surface as that obtained with a new flue, the thickness of the body of the flue does not create a condition which accelerates scale formation, although becoming thinner with age. Further, members of the committee have never been able to obtain more flue mileage from a new flue than a rattled one, if the flues are cleaned properly.

The report was signed by B. F. Sarver, H. R. Mitchell and M. J. Guiry.

#### DISCUSSION

The discussion strayed off into the method of rattling and was very brief. It was suggested that many of the troubles due to rattling were due to carelessness in the doing of the work where the rattlers were neglected and the tubes were allowed to remain in them for a long time so that they were dented or cracked. Where the work is properly done, the tubes are rattled until they are clean and no longer, and then they are taken out and separated at once into lots representing scrap tubes, those that are to be cut and those that are

in good condition. No appreciable difference could be detected in the adherence of the scale due to the method of cleaning the tubes.

As for the cleaning of the inside of tubes of oil burning locomotives there is no difficulty about that, as the regular sanding accomplishes all that is needed. It was recommended that wet rattling be used and that the speed of the rattler be made from 15 to 20 revolutions per minute.

#### WEDNESDAY'S PROCEEDINGS

On Wednesday, May 27, the members visited the plants of the Parkesburg Iron Company at Parkesburg, Pa., and the Lukens Iron & Steel Company at Coatesville, Pa.

#### THURSDAY'S PROCEEDINGS

At the opening of the last session on Thursday morning, May 28, Henry J. Hartley, superintendent of the boiler department of the Wm. Cramp & Sons Ship & Engine Building Company, delivered an address. He spoke first regarding the great developments that have taken place during the past few years in the size and duties of steam boilers, especially those that are used for marine purposes, and then spoke of the importance of hydraulic rivetting as bearing on the efficiency of boilers. He considered it the most important part of a boiler. Defects of design and even of materials may be corrected by careful and skillful workmanship, but when there is a defect in the rivetting it holds until the boiler is in service and then it will manifest itself without fail. Defective rivetting is exceedingly difficult for the inspector to detect and it is only when leakages in service occur that the trouble is seen. The fundamental principle of good rivetting is that the rivets shall completely fill the holes and the fact that they did not fill the holes is the reason why there was so much difficulty with hand rivetting. Weaknesses can often be traced to this because, then, the stress on the rivet is increased and there is apt to be a movement of the plate or the rivet that results in shearing or leaking. It has been found that it is well to have the total area of the rivet sections somewhat more than the net section of the plate.

Again, as the rivet is upset on the point end first, and thus fills the hole at that point it is well to have a fillet at the head end so that, in the driving, the rivet will have a tendency to fill the hole at that point also and thus make a water tight rivet. In heating, it is well to heat the head to a bright cherry red and the point to a dull cherry red. This gives the rivet a tendency to upset more readily under the head and when the machine comes down on the point the result is that the whole hole is filled.

It has been found by careful experiment that for a  $\frac{5}{8}$  in. rivet the static pressure for driving should be about 25 tons; for a  $\frac{3}{4}$  in. rivet about 33 tons; for a  $\frac{7}{8}$  in. rivet, 50 tons; for a 1 in. rivet, 66 tons; for a  $1\frac{1}{8}$  in. rivet, 75 tons, and for a  $1\frac{1}{4}$  in. rivet, 100 tons. When these pressures are reduced to the pressure per square inch of section it will be found to be about 161,000 lb. for a  $\frac{5}{8}$  in. rivet; 150,000 lb. for a  $\frac{3}{4}$  in. rivet; 166,000 lb. for  $\frac{7}{8}$  in. rivets; 165,000 lb. for 1 in. rivets; 150,000 lb. for  $1\frac{1}{8}$  in. rivets; 166,000 lb. for  $1\frac{1}{4}$  in. rivets; the average of the whole being about 163,000 lb. per square inch of section.

John M. Lukens who was to have delivered an address at this time was prevented from so doing by illness and a telegram of sympathy was ordered sent to him.

The report of the committee on topics for the next convention was referred to the executive committee.

#### ELECTION OF OFFICERS

The following officers were elected for the ensuing year: President, James T. Johnston, foreman boiler maker, Santa Fe System; first vice-president, Andrew Greene, general foreman boiler maker, Cleveland, Cincinnati, Chicago & St. Louis; second vice-president, D. A. Lucas, general foreman boiler maker, Chicago, Burlington & Quincy; third vice-president, John B. Tate, foreman boiler maker, Pennsylvania Railroad; fourth vice-president, Charles P. Patrick, foreman boiler maker, Erie Railroad; fifth vice-president, Thomas Lewis, foreman boiler maker, Lehigh

Valley; secretary, Harry D. Vought; treasurer, Frank Gray, foreman boiler maker, Chicago & Alton. Members of the executive board: J. Winterstein, foreman boiler maker, Philadelphia & Reading; Harry Weldin, foreman boiler maker, Pennsylvania Railroad; Thomas Powers, foreman boiler maker, Chicago & North Western.

The Boiler Makers Supply Men's Association elected the following officers: President, J. C. Campbell, Chicago Pneumatic Tool Company; vice-president, D. J. Champion, Champion Rivet Company; secretary and treasurer, Geo. Slate, The Boiler Maker, New York.

## DRILLING THE SMOKEBOX FLANGES OF LOCOMOTIVE CYLINDERS

BY ERNEST W. SLINGSBY

In the accompanying line drawing is shown a device for facilitating the boring of bolt holes in the smokebox flanges of locomotive cylinders. It provides a means whereby the angle of the smokebox flange may be readily changed so that the drilling may be done on a radial drill.

Two heavy cast iron brackets are rigidly bolted to the base

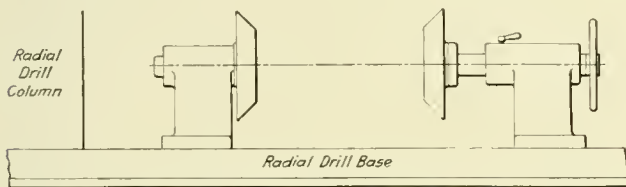

Device for Holding Cylinders While Drilling Smoke Box Flanges

of a radial drill, the arm of which has vertical adjustment. One of the brackets is fitted with a lead screw and clamp such as is used in the tailstock of a lathe. Each bracket is fitted with a large cast iron cone. The cones have a common horizontal axis about which they are free to revolve. The distance between them can be varied by means of the lead screw. As shown in the illustration, the cylinder is clamped and held in correct align-

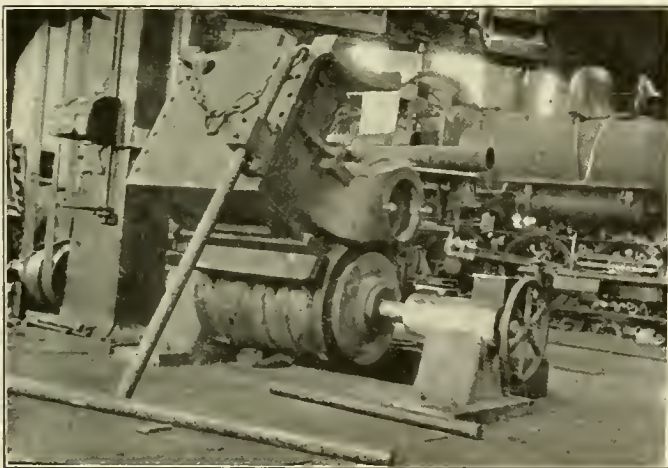

Cylinder in Position for Drilling Smoke Box Flange

ment between the cast iron cones, and in this position is free to revolve about the axis of its bore. The smokebox flange can then be held at any angle desired by means of an adjustable bar bolted to the center facing.

Before this device was installed it was necessary to drill the smokebox flange holes with a pneumatic drill.

TAR FROM COAL.—In Great Britain about 1,325,000 tons of tar are annually produced by the destructive distillation of coal, from which about 10,000,000 gal. of benzol are recovered.

## APPRENTICE MATERIAL

BY A. B. KERR

Instructor of Apprentices, St. Louis & San Francisco, Springfield, Mo.

The old adage, "Be sure you are right and then go ahead" is of more importance today than when it was first spoken, because there are now so many more ways of starting anything. History and experience have so convincingly proved this truth that it is modern practice to eliminate, so far as possible, all chance of failure from any venture or organization.

The selection of the material is the first consideration when an organization is planned, a building proposed or an engine designed. The material is subjected to tests to determine its strength and capacity. Consider the shop of a railroad as a delicate and complex machine. The mechanical appliances such as lathes and planers are supposedly the best of their kind; it is then the men who make the shop efficient or otherwise. As each part of a mechanical device is carefully selected and tested, so should each man be chosen so far as is possible.

If a shop is using material that is full of flaws, it cannot turn out a serviceable finished product. One of the greatest faults of the apprentice system of today is that the "material" is not inspected closely enough; this is the reason the finished product is often of a low standard. While most railways have a certain standard of examination for prospects, yet little or no inquiry is made as to the applicant's character, his morals, his circumstances and his real reasons for entering the apprenticeship. Several concerns maintain bureaus whose specific function it is to supply the different shop departments with systematically selected men.

The recruiting of workmen in the shop is not given the consideration it should have. To obtain men of good character, men who have been trained in the practice of their crafts and who are good mechanics should be the purpose of every employment officer. The company would then have a machine that would produce the best results.

The apprentice system of providing material from which to develop skilled mechanics is much better than the helper plan; industrial instruction increases the ability and capacity of the man, and an efficient man is developed quicker. But in order to obtain worthy boys to take up the trades, they must be shown an inducement. Make the apprentice system so attractive that it will draw desirable material to itself; make the system stand on its own merits. Advertise to all the employees that the system offers an excellent opportunity to their sons; advertise also over all the territory covered by the road. Comprehensive pamphlets describing and illustrating the apprentice work may be distributed to advantage in a manner similar to that followed by the traffic department, taking into account the different fields. The selection of apprentices is a business matter. Yet few roads, if any, openly solicit apprentice material; they choose rather to make a selection from whatever applicants may present themselves.

Boys of good quality must be sought just as any other material of good quality. Some may drift to the shop and apply, but there are many boys of the right kind who have never considered such an action, generally because they do not know the conditions. To them and to their parents the railroad is an employer to be shunned; they think of the work as laborious and dirty, with close confinement, exacting discipline, harsh foremen and small pay.

The officer to whom the prospective apprentice presents himself should be a good judge of boys, in addition to being a close student of human nature. Judging men is different from judging boys. Endeavor to put the boy at his ease and then lead him to talk of himself; of his home; of his friends and his associates; be very much interested; be congenial and sympathetic. Learn the character of the boy; that is the point of vital importance, for it is on this foundation that good mechanics must



be built. Study his morals; a boy of poor morals will not make a much better machinist than he would a preacher. Endeavor to discover what he is naturally fitted for; if a boy's father is a boilermaker and makes more money than a painter, that is no reason why the boy may not be better fitted to be a painter.

Remember that a boy is naturally an individual, but as a boy he has not yet learned those subterfuges practiced by the man in search of employment. If the boy's mind can be put entirely at ease he will appear natural, not as a man, but as a boy, and while talking with him, if possible, form your opinion. If the applicant is a hopeless case, do not lead him on; dismiss him, but advise him. If, however, further investigation is necessary, put the boy to work in the shop as a laborer or helper where he can be watched and perhaps coached. If he seems desirable and you have a vacancy, do not immediately sign him up as an apprentice, but place him in the shops for several weeks as a helper; if after that time he proves fitted to the work, enter him on the apprentice roll.

There are some who reason that this is an undue amount of attention to give to the selection of apprentices, but if it is systematically arranged, all applicants go to the one officer, and if this one man did nothing else but provide the average road with first class apprentices in the mechanical department, a great saving would be effected and efficiency increased. These boys will be the future journeymen, but the very method of selecting

## JIG FOR DRILLING CROSSHEAD SHOES

BY T. F. EATON

Tool Room Foreman, Baltimore & Ohio, Baltimore, Md.

In order to make all crossheads and crosshead shoes of each class interchangeable, so that parts for renewal may be sent out on the line completely finished, a special jig for drilling the shoes was designed by the writer. This jig assures accurate work when used on a drill table which is in good condition.

The construction is simple and inexpensive so far as material is concerned. It was made from two pieces of  $\frac{3}{4}$  in. by 5 in. by 6 in. angle, each 18 in. long. These angles, which are shown at *L* in the illustration, were machined all over with a 4 in. end mill on a large milling machine. They are held together by means of two cast iron cross bars and machine screws *O*; the cross bars are shown at *K*. On each side of the jig are eight hardened tool steel leveling screws *G*, which were ground on a surface grinder after being applied to the jig. Two leveling bars *A* were made from machine steel and each held in place by three screws *M*, together with three of the leveling screws. After securing the leveling bars to the jig, it was placed on a milling machine and the jig holes drilled by using the micrometer attachment. Accuracy in locating the holes was thus obtained. Four hardened and ground tool steel bushings *J* were then pressed into the holes in each bar. Perfect alignment of the bars

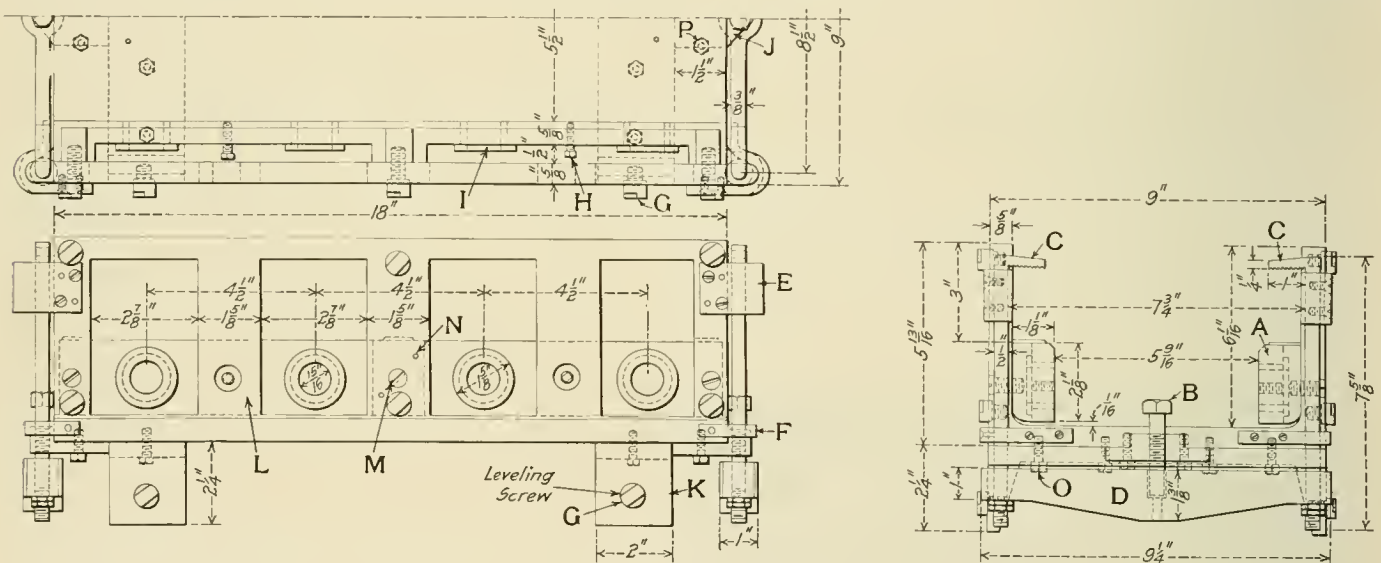

Jig for Drilling Crosshead Shoes.

them has its good effect on the present mechanics. Surely it is contrary to human nature for a body of men not to help a movement that is directed toward the express improvement and the uplift of those in their ranks.

It is very unsatisfactory to be continually disciplining by laying a boy off and by other such forms of punishment. Also, it is still more unsatisfactory to be of necessity dismissing boys during their first six months. Such procedure is demoralizing to the system. When a boy is put at his trade care should be taken to see that he is a pretty safe venture. As the president of a large railway once remarked, "Any fool can fire a man, but it takes a good man to hire one." It is indeed poor practice to fill a vacancy with the first boy who presents himself; far better let the vacancy exist until such time as the desirable boy is found. If the right boy does not apply for the job, hunt him up.

To sum up, maintain a good and thorough apprentice system, make this system of itself attract desirable apprentice applicants, and finally, carefully select from these applicants the ones best fitted to fill such vacancies as may exist. So far as is possible, put the right boy in the right place and then the apprentice system will be a great source of satisfaction to all concerned.

after removing for renewal of the bushings is insured by the dowel pins *N*.

The four clamps *C* were made from tool steel turned to  $\frac{1}{2}$  in. diameter and bent at right angles on one end. Teeth were milled on these clamps and they were hardened and tempered where they grip the crosshead shoe. Each clamp is held firmly to the body by one wide bracket *E*, at the top and one narrow bracket *F*, at the bottom. The clamps are threaded on the lower end and those on each end of the jig pass through a pulling bar *D*, which is held in place by nuts on the lower ends of the clamps. The pulling bar is made from machine steel, finished all over. A boss through the center is counterbored and fitted with a tool steel bushing which receives the end of the tension screw *B*. The tension screw is held in place by the bracket *J*, which is secured to the body by two  $\frac{1}{2}$  in. cap screws, *P*.

Brackets *E* and *F* are made from sheet steel bent over a  $\frac{1}{2}$  in. mandrel and fastened to the body by  $\frac{1}{4}$  in. machine screws and No. 3 dowel pins.

To place a crosshead shoe in the jig the clamps *C* must be turned outward. The shoe is then inserted and the clamps are brought back and adjusted by tension screw *B*. After the shoe

is firmly held the two set screws *H*, which are sharply pointed, are screwed up lightly, preventing the shoe from slipping when the drill strikes sand or blow holes.

### ELECTRIC WELDING AT THE ANGUS SHOPS OF THE CANADIAN PACIFIC

Electric welding, in conjunction with the oxy-acetylene cutting torch, is being very successfully used at the Angus shops of the Canadian Pacific at Montreal. The oxy-acetylene method is

voltage employed being about 70. In firebox patching, the necessary piece is cut out with the oxy-acetylene torch and the edge of the sheet V'd. The old staybolts are knocked out and a

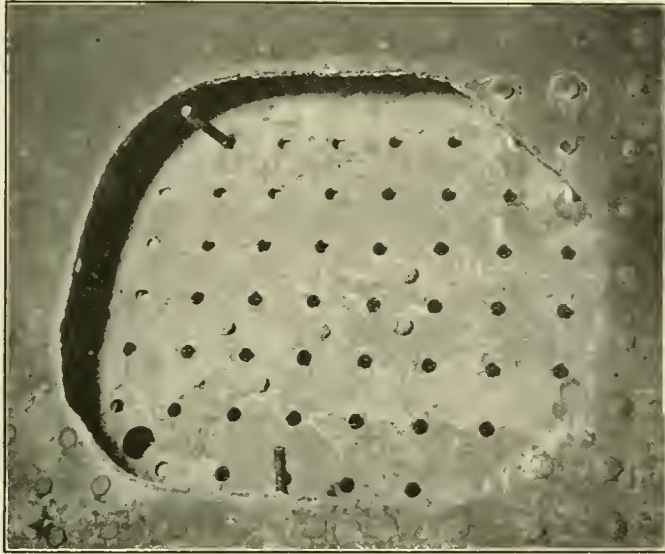

Firebox Sheet After a Defective Piece Has Been Cut Out by the Oxy-Acetylene Torch Preparatory to Patching by Electric Welding

also being employed for filling in flat spots in tires with considerable success.

The illustrations show examples of some of the electric welding in fireboxes and also the various stages in the welding of a broken pedestal on a Pacific type locomotive without removing the frame. The accompanying table also gives the cost of doing this work and the cost under the old method. Similar figures are also given for repairing the fire door which is illustrated; while the broken frame could have been welded in place by oil or other means, such methods have not been found sufficiently satisfactory on the Canadian Pacific. The fire door hole had been in service a year when the photograph was taken. The alternative method in this case would have been to renew the entire sheet instead of resorting to patch bolting.

There are two welding sets in use in the Angus shops, the



Piece Welded in the Corner of a Firebox

patch is laid out using as a pattern the piece removed from the firebox. This also has the edges V'd and is placed in position



A Fire Door Hole Patch Welded in by Electricity

and held by temporary staybolts while being welded. As the heat with the electric system is localized, no trouble is experi-



Broken Pedestal V'd out for Electric Welding

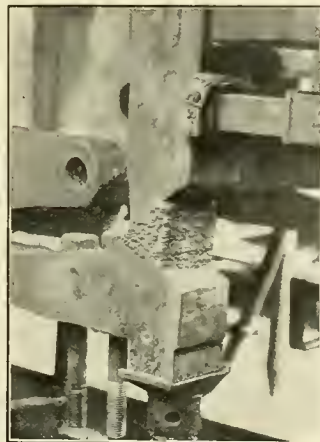

The Pedestal Weld Partly Completed

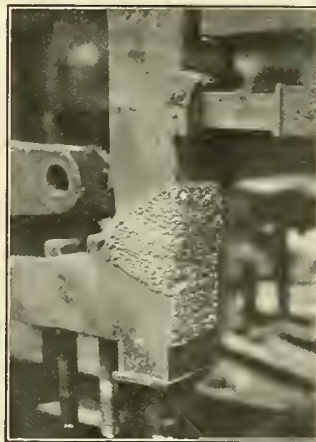

The Completed Weld



The Welded Pedestal After Being Faced Off



enced from expansion. The weld is left slightly raised about the surface of the sheet and rounded.

In renewing fireboxes complete the old one is cut out with the oxy-acetylene torch. Instead of cutting out the seam rivets the torch cuts the seam alongside the line of rivets, avoiding the necessity of drilling the rivets through the heads and punching them out. A firebox can be cut out by means of the torch in four hours.

In filling in flat spots on driving wheel tires the surfaces are

COMPARISON BETWEEN EXPENSE INCURRED IN MAKING REPAIRS WITH THE OXY-ACETYLENE TORCH AND ELECTRIC WELDING AND METHODS EMPLOYED PREVIOUSLY

Defect	Present Method	Alternative Method
Cracks in firebox back sheet.	Cut out defective firehole and sleeve with oxy-acetylene torch, bevel sheet to 45 deg. with air hammer and electrically weld in new firehole, patch and sleeve; also weld short cracks in the sheet. Cost—Labor .....\$23.64 Material ..... 4.61 Total .....\$28.25	Remove back sheet and firehole sleeve complete and replace with new ones. Cost—Labor ..... \$98.58 Material ..... 25.88 Total .....\$124.46
Broken jaw in cast steel main frame.	Cut out wedge piece in location of break, chip faces, clean with air hammer and fill up cavity by electric welding with iron wire. Cost—Labor .....\$3.85 Material ..... 5.01 Total .....\$8.86	Remove frame from engine and transfer it to blacksmith shop; weld frame and remove to machine shop for machine work; return to erecting shop, replace and bolt up on engine, using new bolts. Cost—Labor .....\$28.08 Material ..... 17.90 Total .....\$45.98
Flat spots on driving tires; size from 4 in. to 7½ in. long.	Build up flat spot with oxy-acetylene torch, using tire turnings; dress up true to radius with chisel and file. Average cost per tire, \$2.50.	Remove tire from engine, turn in lathe and replace. (This price includes metal lost in turning.) Average cost per tire, \$12.50.

first slightly roughened and then filled in by oxy-acetylene welding, using tire turnings. The surface is then chipped and filed to a template of tire contour. A similar method is used to fill in holes that are worn oval in rods and motion work.

### DEPTH OF CUT FOR TURNING DRIVING WHEEL TIRES

BY PAUL R. DUFFEY

In order to determine the depth of cut to be taken in turning a set of driving wheel tires, it is necessary to know the amount of flange wear. The wear being known, the depths of the cuts for various amounts of flange wear have been found from observation to be practically as given in the following table:

Flange wear, inches.	Depth of cut to true to gage, inches.	Reduction in diameter, inches.
1/32	1/16	1/8
1/16	1/8	1/4
3/32	3/16	3/8
1/8	1/4	1/2
5/32	5/16	5/8
3/16	11/32	11/16
7/32	3/8	3/4
1/4	7/16	7/8
9/32	1/2	1
5/16	17/32	11/16
11/32	9/16	11/8
3/8	5/8	11/4
13/32	21/32	15/16
7/16	11/16	13/8
15/32	3/4	11/2
1/2	25/32	19/16

These figures will be found useful by operators in setting the tools for a cut, as practically the figures given will prove the correct ratio between tread and flange unless hard or scaly spots are encountered, or excessive hollow wear.

### GRINDING EXHAUST NOZZLES

BY H. C. SPICER

Gang Foreman, Atlantic Coast Line, Waycross, Ga.

In the accompanying illustration is shown an arrangement employed at the Waycross shops of the Atlantic Coast Line for grinding the joint between the bottom of the exhaust pipe and the cylinder saddle. This method has greatly reduced the time required to perform this work and also appears to produce a better joint. It consists of attaching a corner air motor to the smoke box ring by means of a strap iron clamp and connecting to it a small crank. The crank in use has a throw of

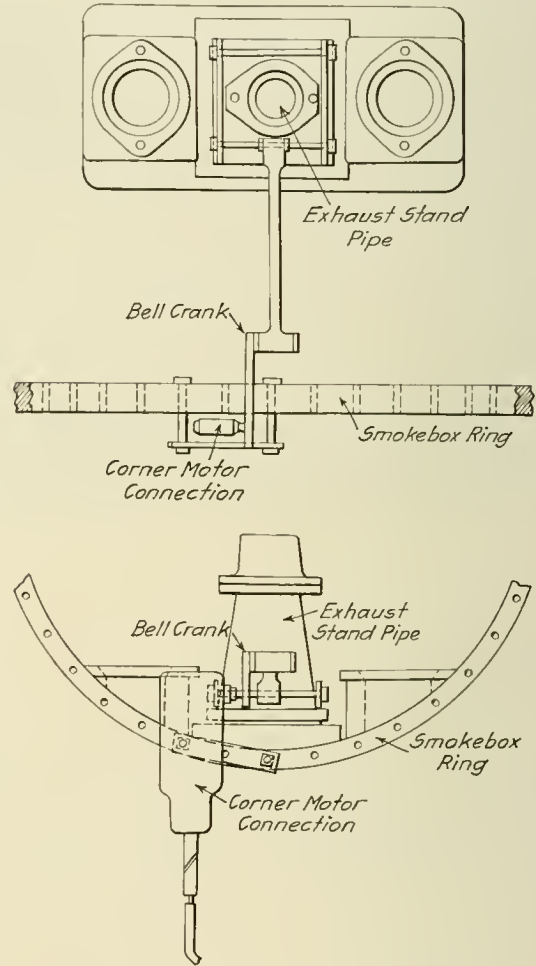

Method of Grinding Exhaust Nozzles

1½ in. The exhaust pipe is secured in a frame arranged for the connection of the rod reaching from the crank on the air motor.

The method of operation needs no explanation. It will be seen that the apparatus is very light, it is easy to attach and costs very little to make.

**SOUTH AFRICAN RAILWAY STRIKE.**—A bill introduced in the house of assembly in Cape Town, South Africa, making special provision for the railwaymen who remained faithful during the recent strike, and also for dealing with the railwaymen who struck, grants the loyal men four days' special leave on full pay, and the railway men who served with the defense force three extra days, also extra pay for specially meritorious service. The strikers who returned to work in accordance with the notices of January 16 and 22 will be fined one and a half day's pay respectively for every day on which they were absent from duty. Strikers who offered their services after January 23 will be re-engaged on condition that they are employed as new hands.

# NEW DEVICES

## PLANER FOR HEAVY WORK

Heavy planers taking work 120 in. wide by 72 in. high, 96 in. wide by 72 in. high, and 86 in. wide by 48 in. high, all of them to plane 18 ft. long, each constructed with two heads on the cross rail and one side head on each upright, have recently been built for the Commonwealth Steel Company, St. Louis, at the Pond Works of the Niles-Bement-Pond Company. These planers are constructed for heavy duty on steel castings, requiring a construction of great rigidity.

The illustration shows an 86 in. by 48 in. by 18 ft. planer which is used in machining open hearth cast steel combined double body bolsters and platforms. It is also used in machining steel truck frames and one-piece tender underframes. All of these

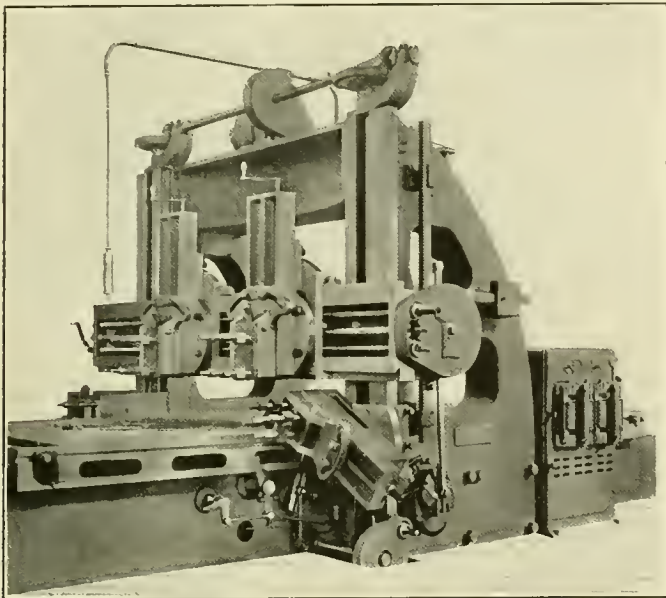

Planer for Heavy Work

castings require extensive machining to assure accuracy of alignment of the attached parts.

The planer is 88 in. wide between uprights, takes 50 in. between the table and the crossrail and planes 18 ft. long, the table being 80 in. wide and 20 ft. long over all. The planer is driven by a 50 h. p. reversing motor directly connected to the gearing. The speed of the table is adjustable without stopping, by hand wheels conveniently located on the controller, between the limits of 25 ft. and 50 ft. per minute for the cutting stroke, and between 50 ft. and 90 ft. per minute for the return stroke. The driving motor is directly connected to the first driving shaft at the back of the planer, out of the way of the operator. The controller, resistance, pilot switch and circuit breaker are mounted in a ventilated cabinet which also contains all wiring except the wires from the controller to the motor. These are carried across the planer bed in a metal conduit.

Operating levers on the front and back of the bed are connected to the reversing switch. These may be operated by hand or automatically by adjustable dogs on the table. At the instant of reversal the motor is automatically disconnected from the line and becomes a powerful dynamic brake, stopping the table at once without taking current from the line.

A patented pendant switch carried by a swiveling bracket mounted on the arch may be moved by the operator to any convenient position, and gives him control of the driving motor for

starting, stopping or reversing the table, if the work requires him to be in such location that he cannot reach the levers on the front or back sides of the bed.

To prevent the table from running off the gearing should the line current fail, or the breakage of either tools or planer from overload, a patent circuit breaker is provided which will stop the motor at once, by dynamic braking.

The crossrail is raised and lowered by an independent reversible motor mounted on the arch.

## TRIPLEX HYDRAULIC PUMP

The accompanying illustration shows a vertical type of single acting, triplex hydraulic pump recently brought out by the Hydraulic Press Manufacturing Company, Mount Gilead, Ohio. This pump is made in three series of sizes; one of these has a stroke of 8 in., and is equipped with plungers  $\frac{7}{8}$  in. to  $3\frac{1}{4}$  in. in diameter; the second has a stroke of 12 in. and plungers 1 in. to  $4\frac{1}{2}$  in. in diameter; while the third has a stroke of 12 in., and plungers  $1\frac{1}{4}$  in. to 5 in. in diameter. A range of pressure capacity from 600 lb. to 16,000 lb. per square inch is obtainable, depending on the size of the piston. The drive may be either by belt or electric motor. The pumps are fitted with screw

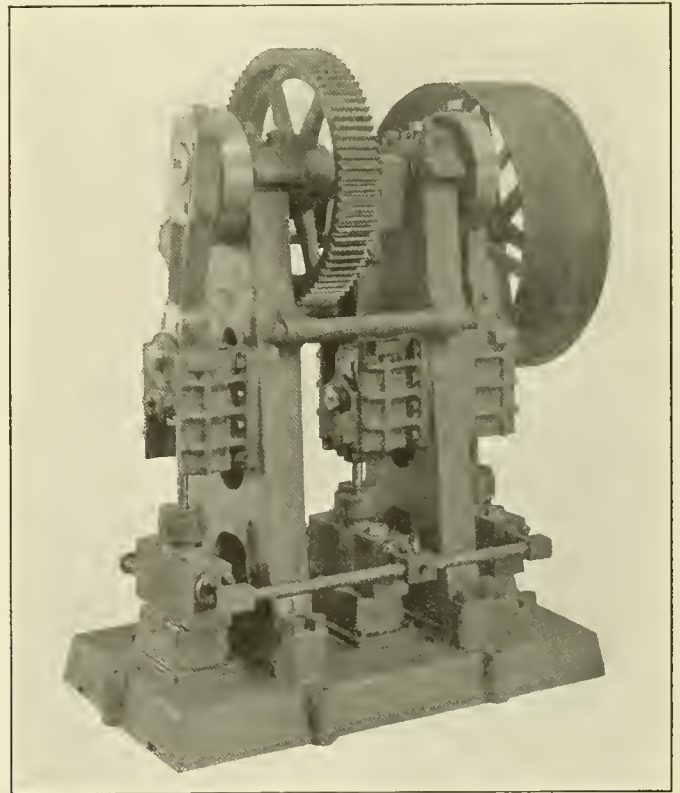

Single Acting Triplex Hydraulic Pump

glands working against followers when equipped for high pressure work, or with stud glands when equipped with large pistons for low pressure work. The pistons are packed with compression packing. Forged steel is used in the construction of the high pressure pump cylinders and crank shafts.

When the pump is operated by a belt it has a single reduction of gears for the first size, and a double reduction for the other



two. The pulleys can be arranged to drive from either end. When a motor is used it has a double reduction of gears for all sizes. The first reduction has a ratio of 5 to 1, while the second reduction depends on the speed of the motor used. The height of the first mentioned size is 5 ft. 9 in.; the second 8 ft. 1½ in., and the third 8 ft. 10 in.

## ARC WELDING

The Westinghouse Electric & Manufacturing Company, East Pittsburgh, Pa., has developed a standard line of electric arc welding equipments. These are simple in construction and easy to operate. Complicated relay methods for automatically inserting resistances are eliminated. Protection is

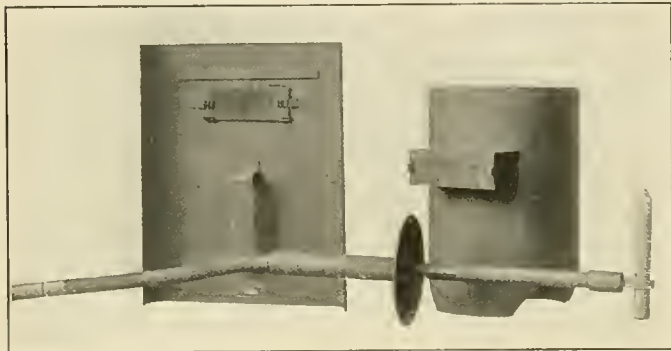

Shield, Hood and Carbon Holder

secured by circuit-breakers and special arrangement of the resistance.

The outfits are made complete in 200, 300, 500 and 800 ampere sizes. Each equipment includes a welding generator, or a welding motor-generator set, switchboard, control and all necessary accessories. The welding generator consists of a special 75-volt, commutating-pole, direct-current machine,

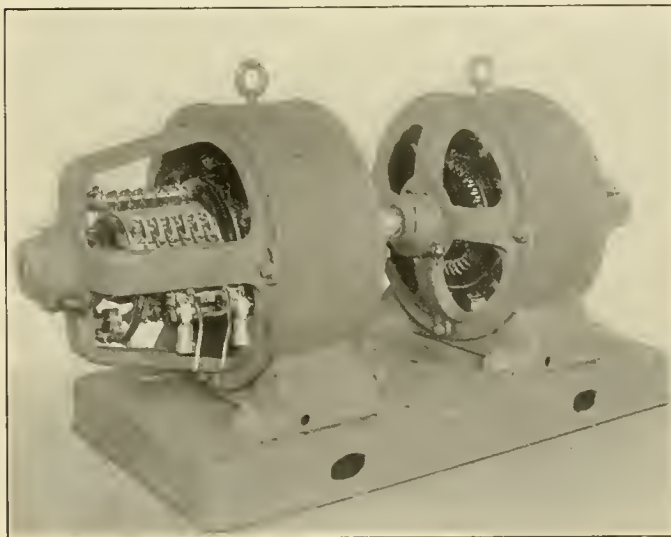

Motor-Generator Set for Arc Welding

either belt or motor-driven. The instrument and control panels are composed of two sections. The upper section contains the indicating instruments, protective apparatus and switches arranged for regulating the welding current, and the lower section contains the starting and protective equipment for the motor-generator set. As it is sometimes desired to have several welding circuits connected to one generator, a control panel is provided for each circuit. Each panel can be

located at the most desirable place. Metal or carbon pencil welding can be done from any of these panels, independent of all others, and one or more arcs can be operated simultaneously. The accessories consist of a carbon holder and a hood for protecting the operator, together with a shield and a metal pencil holder for each welding circuit.

This equipment is the result of eight years' experience in



Surface Built Up on a Truck Casting

the shops of the Westinghouse Electric & Manufacturing Company, and has been employed on all classes of commercial work.

## BRONZE BEARING METAL FOR TRUCK JOURNALS

A bronze bearing metal composed of 65 per cent copper, 30 per cent lead and 5 per cent tin, has recently been tested by the Baltimore & Ohio. A 22 lb. brass, used without babbitt was placed under the tender of a Pacific type locomotive. After the engine had run 51,000 miles an examination of the bearing was made. It was said to have been worn 1/32 in., and had made this mileage without running hot at any time. Other bearings on the tender were said to have been re-babbitted six times each.

For mill purposes, this bronze, which is treated in crucibles, may be hardened into what are claimed to be very superior mill brasses. A test of this nature is reported with two 75 lb. mill brasses used under the rolling table of a 108 in. plate mill, the minimum weight of which is estimated at 10,000 lb. It is stated that the two brasses gave continuous service for four weeks, or twice as long as the ordinary phosphor bronze. On account of the position of the bearings it was impossible to lubricate them during the test. It is stated that the graphite in the lead acts as a lubricant thereby effecting a reduction in the amount of oil used.

This metal is the product of the American Metal Company, Pittsburgh, Pa.

**MARCH MOVEMENT OF ANTHRACITE.**—Shipments of anthracite coal during March were 255,515 tons more than in March, 1913, in spite of the light demand for coal. They amounted to 5,164,703 tons, as against 4,909,288 the previous year. The amount of coal on hand at tidewater shipping ports increased 109,307 tons, from 523,682 tons on February 28 to 632,989 tons on March 31.

## HANCOCK COAL SPRINKLER

A sprinkler manufactured by the Hancock Inspirator Company, New York, for wetting down the coal on locomotives, was described in the *Railway Age Gazette*, Mechanical Edition, June, 1913, page 334, and an improved form in the issue of September, 1913, page 510. A further development of this device, superseding the other two forms, has recently been brought out.

This sprinkler acts on the principle of an ejector. The principal feature is a valve which automatically discriminates between steam and water and whose action prevents any sudden and unexpected discharge of steam through the hose. The de-

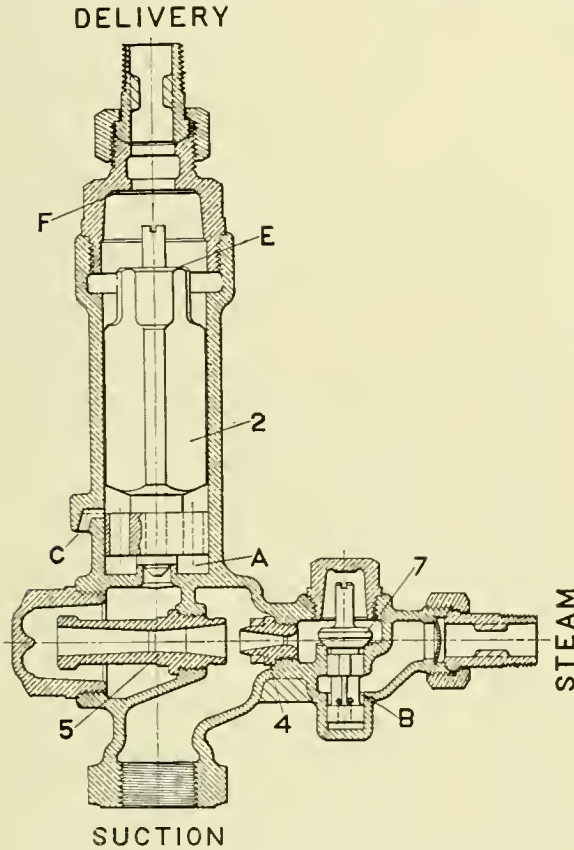

Section Through Improved Hancock Coal Sprinkler

vice is generally applied on the strainer or on the suction pipe of the injector by the use of a short connecting nipple having a bend so that the sprinkler will be in a vertical position. A valve is placed in the steam pipe at a point where it can be conveniently reached.

In operating the coal sprinkler, the steam valve in the pipe is opened wide, which action opens valve 7. This also closes the drip hole B, the piston end on the lower end of the guiding stem covering the hole. Steam will now flow through nozzle 4 forming a jet and combining with water in tube 5. There will not, however, be a flow of steam in starting, as tubes 4 and 5 are always under water because of the location of the sprinkler at a point lower than the tank.

Steam flows into the pressure chamber A and valve 2 is raised. Port C is also closed and the water is forced through the delivery pipe to the hose.

Should the flow of water be interrupted or the injector refuse to work, valve 2, which discriminates between steam and water, will close the sprinkler so that no steam escapes to the hose. The steam, under these conditions, flows into the pressure chamber A and forces valve 2 upward. The end E of valve 2 seats against the surface F, thus making it impossible for steam to flow to the delivery tube. When not operating, both valves

will seat. The valve 2 is heavy enough to prevent water flowing up the delivery pipe, and all the water in the delivery pipe will flow out of the drain hole C. At the same time the steam valve 7 will seat, preventing water from flowing up the steam pipe and all water or steam in the latter will drain out at the hole B. The sprinkler uses comparatively cold water, no steam can escape, and it is self-draining.

## OXY-ACETYLENE WELDING APPLIED TO MANUFACTURING

A good example of the increased efficiency and generally decreased cost of manufacture effected by welding sheet steel articles as compared with drilling and riveting is shown in the steel truck made by the Standard Improved Truck Company, Chicago.

The warehouse truck which is shown in the illustration was formerly made by drilling and riveting all joints. Welding by the Oxweld process was proposed and a test truck made by this method. Results of the tests made to determine the relative strength of welded joints compared with riveted joints were so conclusively in favor of the welded joints that the welding process was immediately adopted.

Welding has not only produced a truck of greatly increased strength and rigidity, but has increased the output per man about 20 per cent with a saving of more than 30 per cent over the previous cost of manufacture.

The following is a summary of the report of the tests re-

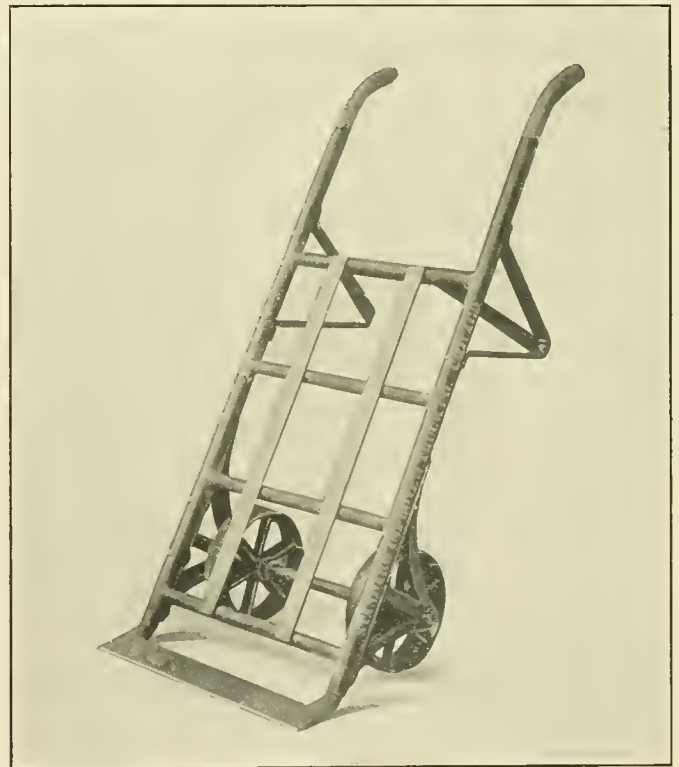

Truck with Oxy-Acetylene Welded Joints

ferred to, which were made by the Bureau of Inspection, Tests and Construction of Robert W. Hunt & Company, engineers. Three connections were submitted, each consisting of a portion of stringer tube and cross tube secured together by one of the following types of joints: connection A welded by oxy-acetylene torch; connection B riveted with two 1/4 in. diameter rivets in double shear, one in the stringer and one in the cross tube through a plug and bushing inserted in the cross tube; and connection C riveted with 1/4 in. rivet in double shear through the



cross tube and  $\frac{1}{4}$  in. riveted reduction of inserted plug through the stringer tube, the head being in tension.

The three connections were subjected to tests under identical conditions. In each case the stringer tube was supported as a beam at points close to and on either side of the cross tube. The joint was then destroyed by tension in the cross tube.

Connection *A* failed at the weld under a maximum load of 25,460 lb. Under a load of 17,090 lb. the cross tube, on which the tension was applied, commenced to scale, indicating that the elastic limit of the steel in tension had been reached.

Connection *B* failed by shearing the rivets in the stringer tube under a maximum load of 4,740 lb.

Connection *C* failed under a maximum load of 5,800 lb. by shearing off the rivet in the cross tube and pulling through the rivet connection in the stringer tube.

## HORIZONTAL DRILLING MACHINE

A horizontal drilling machine designed for heavy work with high speed drills in hard material has recently been brought out by the Detrick & Harvey Machine Company, Baltimore, Md.

The general design is similar to that of a horizontal boring and drilling machine of the traversing column type, having a fixed work table, a column traversing horizontally on the runway and a saddle traveling vertically on the column.

The spindle is of hammered high carbon steel with a tapered front bearing  $7\frac{3}{8}$  in. in diameter running in a phosphor bronze

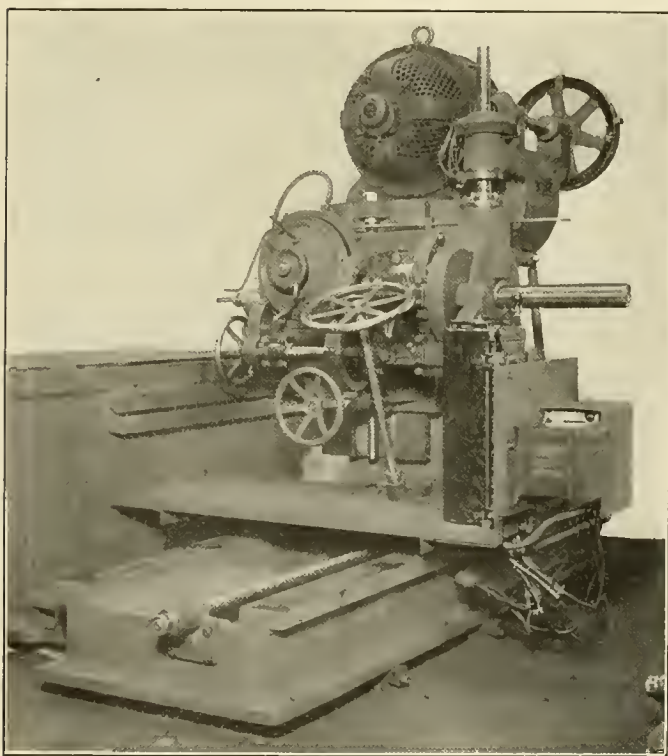

High Speed Horizontal Drilling Machine for Heavy Work

bushing, with adjustment for taking up wear. It has a dust proof roller thrust bearing and is provided with a standard taper socket hole. The spindle is driven by a 20 h. p. 4 to 1 variable speed motor, mounted on the top of the column. All driving gears are of cast steel or manganese bronze, while the pinions are of high carbon steel. No belts or chains are used on the drive or feeds. The spindle speeds range from 60 to 240 r. p. m.

The power feed is driven from the spindle sleeve gear and has all steel gears and clutches with a steel pinion engaging in a rack which is cut from the solid on the steel feed quill. There are four changes of feed ranging from .004 to .09.

The vertical movement of the saddle and the horizontal movement of the column are obtained through hand wheels conveniently located at the operator's platform; the column is mounted on rollers to reduce friction on the runway. Both the saddle and the column may be changed to any required position, and have gibs for taking up wear.

The controller for the motor is also mounted on the operator's platform. An oil jet is provided for the drill and is fed from a rotary pump driven by a small auxiliary motor. The work table is provided with a gutter around all four sides by means of which the oil is returned to the supply tank of the pump. All gears are completely covered.

As shown in the illustration, the machine has a high box work table permitting the spindle to be brought down within 3 in. of it. A vertical adjustment of 12 in. and a horizontal adjustment of 6 ft. are obtainable.

## STRAINER AND DRAIN VALVE

The purpose of the Watters strainer and drain valve shown in the engraving is to avoid the difficulties resulting from injector failures due to the clogging of the suction pipe with coal and other foreign matter, and also to provide an efficient and simple means of cleaning the pipe or tank in freezing weather without disconnecting or taking anything apart. When the injector fails or for other reasons it is desired to clean out the pipe, the valve which carries the strainer is lifted and an opening is provided which is sufficient to permit the dirt to wash out quickly. When used as a drain the valve is lifted and the

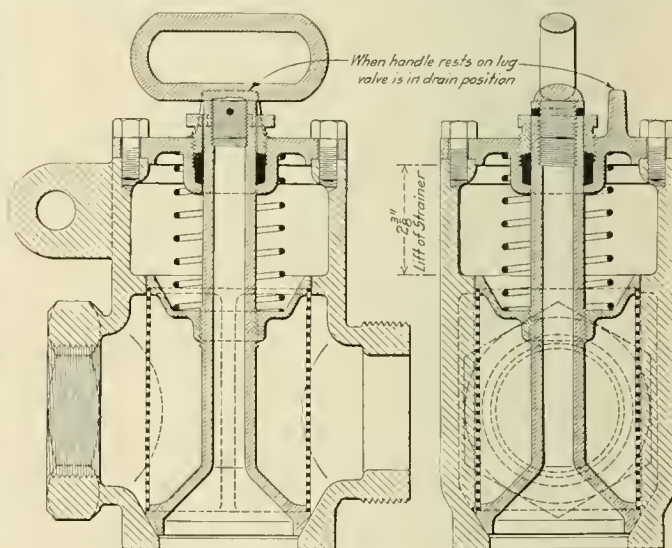

Strainer and Drain Valve for Injector Suction Pipes

handle allowed to rest on the lug shown on the top of the cover. In this position an opening of about  $\frac{1}{4}$  in. is provided which takes care of any leakage. It is claimed that this feature entirely eliminates trouble from frozen pipes in cold weather. When it is desired to empty the tank it is only necessary to lift the valve to its full opening. This device can be installed in any part of the pipe line between the tank and the injector, but should preferably be placed at the lowest point. Where it is convenient, the lifting handle can be extended up through the cab or tender floor by an extension of the valve stem. In a closed position the valve is held on its seat by its own weight and a spring. This valve is manufactured by the Railway Supply & Equipment Company, Candler building, Atlanta, Ga.

**WIRELESS TELEGRAPHY.**—A wireless triumph was achieved on February 11, when the New Sayville, Long Island, wireless station succeeded in establishing communication with Nauen, near Berlin, a distance of over 4,000 miles.

## INTERESTING ADAPTATION OF ELECTRIC HAND DRILL

The combination portable electric hand drill and sensitive drilling stand, which is shown in the illustration, has recently been developed by The Cincinnati Electrical Tool Company, Cincinnati, Ohio. The electric hand drill may be detached from the bracket and used independently. This operation is a simple one, requiring only the adjustment of the two thumb nuts, which release the hinged caps that lock it in the bracket.

The bracket which carries the drill may be adjusted in any position on the column by means of the clamping screws. When clamped in position it has a vertical adjustment, or feed, of 3

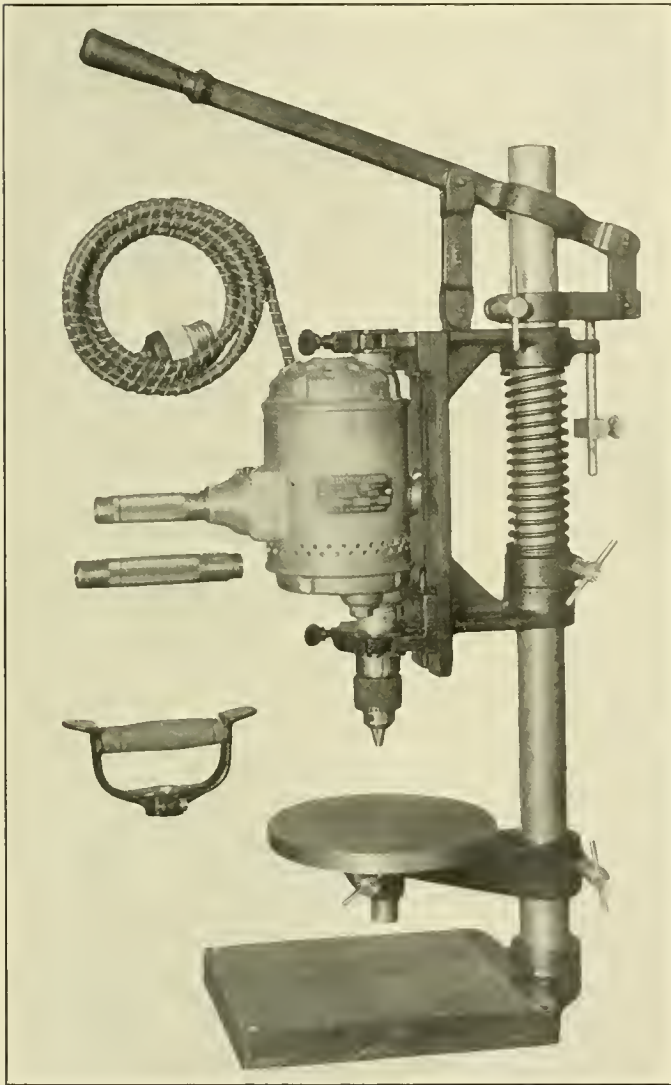

Combination Portable Electric Hand Drill and Sensitive Drilling Stand

in., which is controlled by the hand lever. A stop on the column regulates the depth of the holes to be drilled. The drilling stand has been designed to receive electric hand drills of  $\frac{1}{4}$  in.,  $\frac{3}{8}$  in. and  $\frac{1}{2}$  in. capacity and weighs 60 lb. The table is 8 in. in diameter and may be adjusted to any height on the column; if it is desired it may be swung to one side out of the way. The distance from the column to the center of the table is 5 in. The column is 30 in. high and  $1\frac{3}{4}$  in. in diameter, and the base measures 9 in. by 11 in.

TRIAL OF THE TRIPLEX LOCOMOTIVE.—The triplex compound for the Erie was recently tried out on the Baltimore & Ohio.

## HEAVY SERVICE SHAPER

A new design of heavy service shaper has been brought out by the American Tool Works Company, Cincinnati, Ohio. One of the first points considered when laying out this machine was that of power input. The approximate power a shaper of this kind would require for performing the heaviest classes of work was determined, then sufficient extra power added to provide a safe working margin; consequently, this machine, when doing the average heavy work, should not be constantly working up to the limit of its capacity. The cone steps are large in diameter and wide of face, being arranged to accommodate a 3 in. belt. The countershaft speeds are high and the back gear ratios are higher than usual on standard shapers of this size.

A range of eight strokes from  $6\frac{1}{2}$  to 90 per minute has been provided, this range being in geometrical progression and calculated to give the best results on all classes of work. It was found that a slower speed than  $6\frac{1}{2}$  is unnecessary and a speed faster than 90 impracticable on account of the excess of vibration caused by the rapid stroke. The length of the stroke may be easily changed at will without stopping the machine.

The ram and rocker arm are of an improved design which

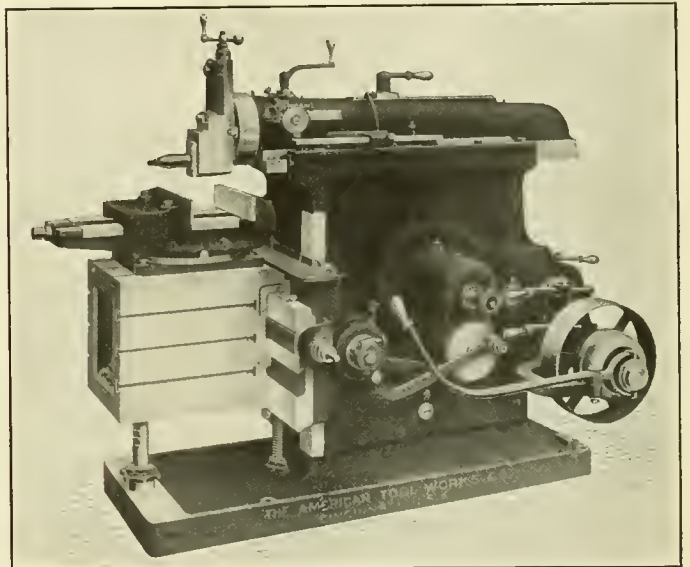

Shaper Designed for Heavy Work

provides a rigid construction. The rocker arm is rigidly connected to a pivot shaft at the bottom of the column which supports all the weight of the arm and other parts, thus relieving the ram from any dead weight and eliminating undue vibration. The connection between the rocker arm and the ram is by means of a double link which is so arranged that it pulls down on the ram during the cutting stroke, thus tending to neutralize the upward thrust of the tool. A reduction in wear of the ram bearings is effected by relieving the ram of the weight of the rocker arm.

One of the features most essential to the life and accuracy of any shaper is an effective means for taking up the wear. The continuous taper gib used on this shaper provides a means by which a full length bearing can be maintained and the rate of wear kept down to a minimum.

The cross feed is of a new design for which a number of advantages are claimed. It is both automatic and variable, providing a range of graduated feeds, 32 in number. These can be changed and accurately set while the machine is running by means of a conveniently located knurled knob. The feed is thrown in or out and reversed by a knob on the feed





## PORTABLE RADIAL SWING GRINDER

The grinding machine illustrated is made for grinding castings and doing other general buffing work. It is self-contained and is driven by a motor mounted on a suitable platform which is part of the main housing; the counterbalance for the swinging arm and grinding head is also mounted on the main housing. The machine needs no preliminary work for setting up and can be carried anywhere by a crane.

The arm with the grinding head can be turned through the entire circumference about the base. The grinding head and the swinging arm are carried back and forth by a roller bearing trolley which rolls on a track held in a horizontal position by two parallel arms. At the back end of these arms is placed the counterweight. The parallel arms keep the head balanced in any position the trolley may occupy on the track. This arrangement gives a free movement to the swinging arm and eliminates the tendency of the arm with its weight to find its center of gravity. The grinding head can be twisted in either direction to an angle of 90 deg. The emery wheel is driven by a single belt which is carried around the jointed connection of the swinging arm and hanging swing frame by two self-oiling idler pulleys, thence to the large pulley at the top. The upper pulley is driven by a shaft from the drive pulley on the inside of the housing. The motor is belted to this drive pulley. The swing frame hangs on two phosphor bronze bushings placed in the top bracket. These bushings form the bearings for the drive pulley.

The emery wheel in the grinding head is shielded by a hood over the top. The handles attached to the head enable the operator to obtain a good hold and to have full control of the head. The wheel arbor runs in phosphor bronze bearings with provision for taking up the wear. It has safety flanges and will

## BALL BEARINGS ON TURNTABLES

BY ARTHUR V. FARR

The application of ball bearings to railway turntables in this country, up to the present time, has not been investigated to any considerable extent. It has been left to the foreign railways to adopt ball bearings for this purpose, and they have found them so advantageous that their use has become quite common.

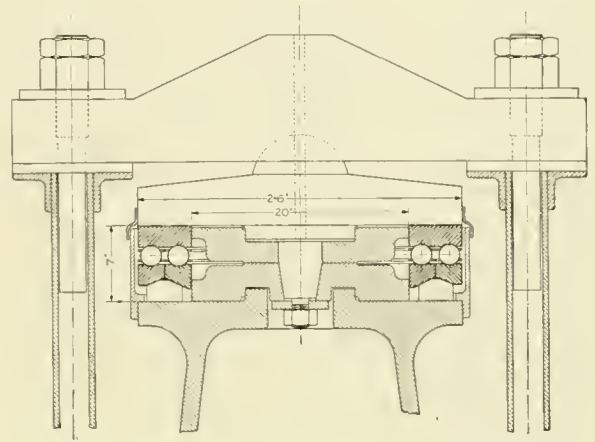

Section Through the Center Support of a Ball-Bearing Turntable Used by the Victorian State Railway, Australia

The Victorian State Railway in Australia has equipped its roundhouses and terminals with ball bearing turntables, and after a period extending from 1911, this road has experienced such satisfaction that they are ordering large numbers of additional

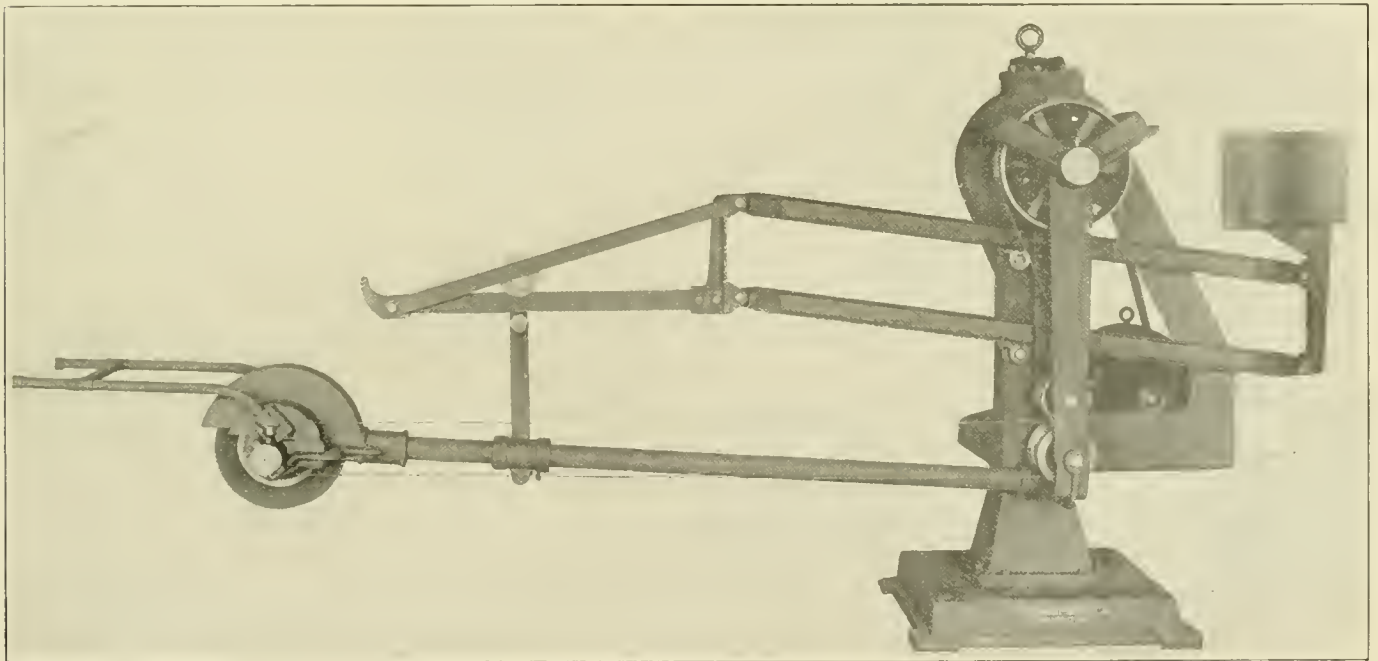

Portable Radial Swing Grinder

take a wheel 18 in. diameter by 3 in. face. A safety shaped wheel is recommended.

This machine is manufactured by the Mummert-Dixon Company, Hanover, Pa.

**SPEED OF NEW DESTROYER.**—While running her standardization trials the new destroyer *MacDougal* made a maximum speed of 32.07 knots for one mile and averaged for five full-speed runs 31.52 knots.—*Scientific American*.

ball bearings for this purpose. In the accompanying drawing a Victorian State Railway turntable of 200 tons capacity, equipped with S. K. F. ball bearings, is shown. It will be noted that there are two rows of large (2 in.) balls in this bearing arranged in staggered relation. This is a double thrust bearing of special construction, mounted in the center of the turntable in such a way as to act as a pivot. The Victorian State Railway has been using these ball bearings for turntables for capacities ranging from 150 to 225 tons.



One advantage of using this type of ball bearing is that any unbalanced load on the table is taken care of by the pivot plate, and the whole load is uniformly distributed to both rows of balls by the use of a self-adjusting ring supporting the two lower ball races. A steel shell surrounding the thrust bearing serves to retain the lubricant and to keep it free from the possible intrusion of dust and grit, insuring the greatest degree of reliability, and preserving the accuracy of the ball bearings for the table support.

### GRINDING MACHINE OF THE OPEN SIDE PLANER TYPE

A grinding machine of the open side planer type suitable for grinding frogs, switches, crossings and other similar work, employing materials not workable with steel cutting tools, is shown in the accompanying illustration.

The machine, which is built by the Detrick & Harvey Machine Company, Baltimore, Md., consists of the regular reciprocating table, bed, post and cross beam of the standard open side planer built by the same manufacturers. In place of the ordinary cutting tool is substituted a grinding wheel carried in a saddle which can be fed up or down, or in either direction laterally. The grinding wheel is mounted on a spindle which bears in long bronze bushings, and is belt driven from an independent electric motor mounted on the saddle.

The saddle has a sliding fit on the cross beam and can be traversed by hand from either side of the machine. A power

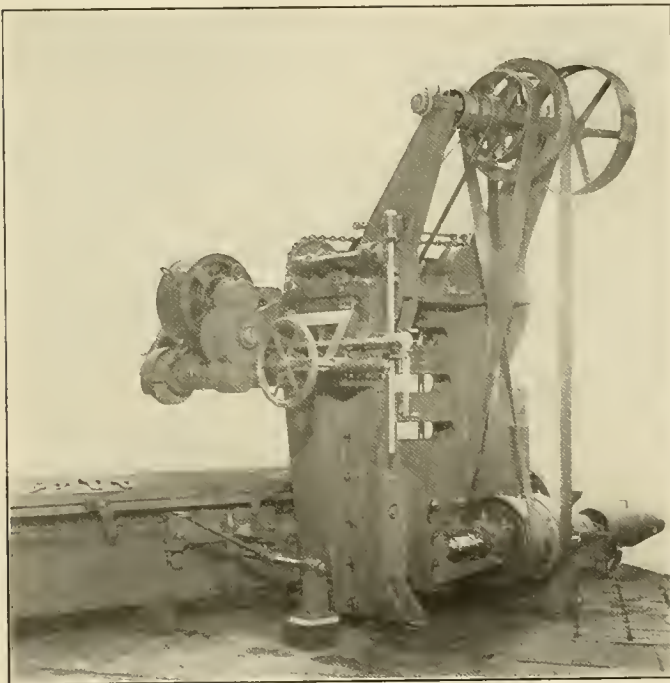

Open Side Planer Type Grinding Machine

cross feed can also be provided. The cross rail is carried on the face of the post with a sliding fit and can be fed up or down by hand, and adjusted by hand or power as desired. Being fully counterbalanced it is easily adjusted.

The table is gibbed down on the side next to the post. It is driven by a spiral pinion and rack. The reverse is obtained through shifting belts or a reversing motor as desired. The table drive in a belt driven machine is accomplished through a countershaft mounted on the post. It is independent of the drive for the grinding wheel and may be by belt from motor or line shaft or by direct connected reversing motor.

The grinding wheel is 18 in. in diameter by 3 in. face, run-

ning at about 1,300 r. p. m. The speed of the table is 40 ft. per minute, the speed being the same in both directions.

### LONG DISTANCE GASOLENE AND OIL PUMP

The accompanying illustration shows a long distance 5 gal. pump recently brought out by S. F. Bowser & Company, Inc., Ft. Wayne, Ind., which will be found useful in railroad oil houses where saving of time is an important item. The pump delivers quickly large quantities of gasolene or other oils with but little labor and without the tediousness usually experienced with the ordinary self-measuring pump, the plunger being returned to its original position with a few quick, easy turns of the handle. It takes but little room in the building and is

flexible as to range of quantities measured.

This pump is designed for measuring and distributing either volatile or non-volatile oils, varnishes, etc. It may be located at any convenient point within the building and connected to a tank located at any distance from the pump, provided the vertical suction is not more than 12 ft. It is so arranged that at the option of the operator, by adjusting a stop on the quantity rod, 5 gal., 2 gal. or 1 gal. may be discharged at one stroke. The different measurements are regulated by adjusting the stops on the pump, which is very easily and quickly done. It is also provided with a graduated scale showing all intermediate gallons, half gallons, quarts or pints, making the pump virtually one

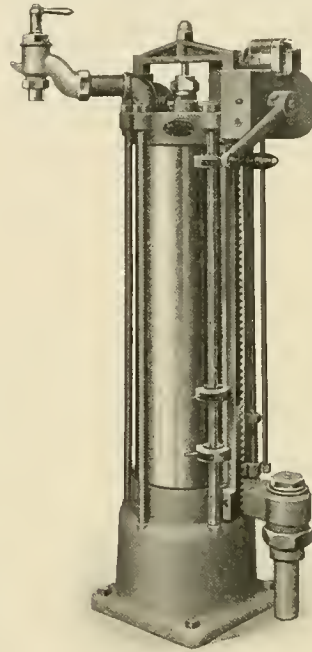

Five-Gallon Pump for Oil or Gasolene

with a maximum capacity of 5 gal., and a minimum of one pint, so that any intermediate quantity can be pumped and accurately measured. Gears on the pump are designed to provide a quick return motion, so that one revolution on the return is equal to six revolutions of the handle on the upward stroke. Two cross bars are provided which evenly distribute the weight of the plunger, making the pump easy of operation.

Located in the head of the pump is a discharging register which tallies the number of gallons pumped, in multiples of five up to 50 and then repeats. A meter is also provided which registers all liquid discharged, to 100,000 gal., and then repeats.

The pump is provided with a locking device so that it can be operated only by those persons in possession of a key.

**QUICKER SERVICE BETWEEN LONDON AND PARIS.**—At a conference held recently in Paris between representatives of the Brighton Railway Company and officials of the State railways of France, many improvements and accelerations in the services between London and Paris, via Newhaven and Dieppe, were arranged to come into operation next year. The morning services from London and Paris will be accelerated by about half an hour in each direction, and an afternoon service between London and Paris will be run during the summer months.

### ADJUSTABLE PLIERS

A hand tool of general utility is shown in the accompanying illustrations. The device consists of pliers provided with one jointed lever, enabling the movement of the jaws independently of the handles. One of the designs is made with a worm thumb nut, making it thoroughly adjustable, it being possible while the tool is in use in any capacity to definitely locate the jaws in any

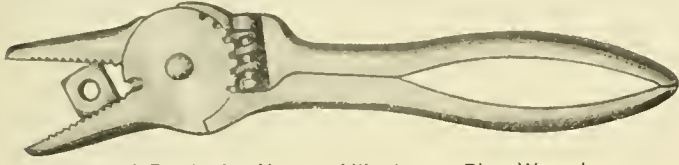

Tool Ready for Use as Alligator or Pipe Wrench

position up to 30 deg. without movement of the handles. This feature gives the added advantage of a convenient tool for gripping and holding round bolts from turning, as well as for use on pipe and various sizes of nuts. The spread of the jaws is limited to an angle of 30 deg. by a double set of shoulders forming a rigid wrench, while at the same time the handles may be closed firmly together for a convenient grip. In using the tool as pliers,

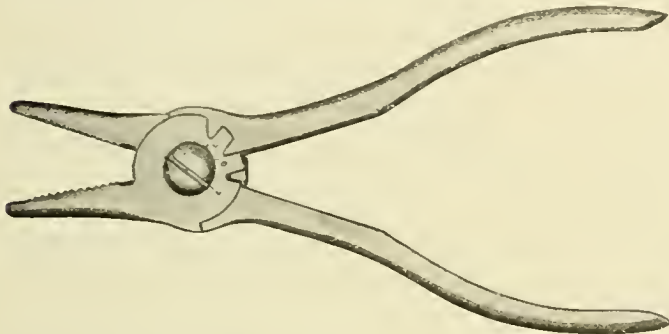

Tool Arranged as Pliers and Wire Cutter

when the jaws are spread at a broad angle covering a big job, the handles may be run down, approaching each other, for convenience in gripping.

The tool was invented by J. H. Baldwin, 1002 North Jefferson street, Springfield, Mo.

### HIGH PRESSURE VOLUMETRIC AIR METER

An air meter for measuring compressor output, pneumatic tool consumption and pipe line losses has recently been introduced by the Kreutzberg Meter Company, Chicago, Ill. The

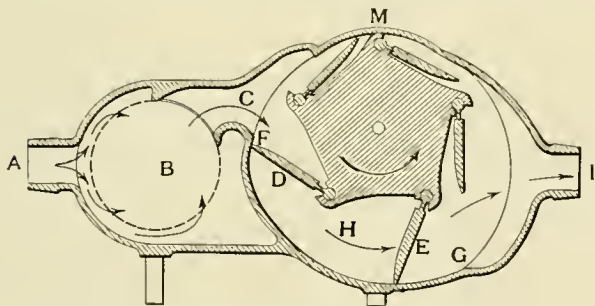

Section Showing Operating Parts of Volumetric Air Meter

meter is light and simple in construction and can be cut into a pipe line with little delay by any workman. The weight of the one inch size, for pressures up to 150 lb., is 28 lb.

A cross section of the case and operating parts of the meter

is shown in the engraving. Opening *A* at the left is the inlet through which air is admitted to screen chamber *B*. From there it passes into the meter through *C*, impinging against vane *D* and causing the drum to rotate. As vane *D* passes the point of cutoff at *F* a fixed volume is contained between the vanes *D* and *E*. As soon as vane *E* reaches the point of outlet *G* the pressure in pocket *H* and the pipe line *I* are equalized and the contents of pocket *H* are discharged into the pipe line. The meter is sealed at the top by the shoe *M*.

The energy required to operate the meter is claimed to be very small. The difference in pressure between the inlet and outlet of the meter will therefore be slight and leakage is unlikely to become an important factor in its operation.

### LARGE RADIAL DRILL FOR HEAVY DUTY

The 5 ft., round column radial drill which is shown in the illustration is of similar construction to the 3 ft., round column drill which was fully illustrated and described on page 619 of the November, 1913, issue of this journal. Both machines are built by the Fostick Machine Tool Company, Cincinnati, Ohio.

Aside from its greater size and capacity the 5 ft. drill differs principally from the earlier machine in the design of the table and base. For heavy steel drilling and tapping operations a liberal oil channel is cast around the base. The channel passes completely around the column where it drains into a large reservoir. This construction permits a full ribbed cross section of the base at a point immediately in front of the column where the greatest rigidity is required, and allows the outside T slots to extend back beyond the front of the column, making the full working surface of the base available.

Special attention is called to the location of the table which is also provided with oil channels draining to a pocket in one cor-

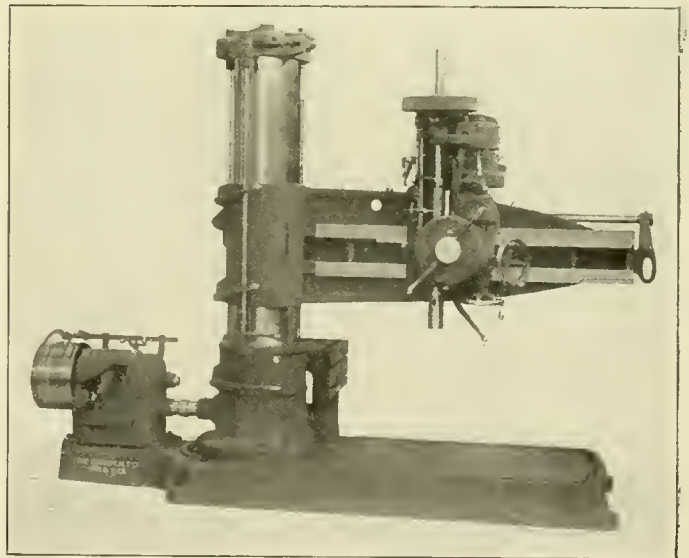

Heavy 5-ft. Radial Drill

ner. Any convenient receptacle may be placed at this point to receive the lubricant, thus eliminating the necessity of a pump.

The efficiency of this machine is claimed to be high, as will be noted by the results of tests given below. These tests were made in machine steel 1½ in. thick on a stock machine, feed box driven, with the belt and frictions operating under ordinary conditions.

Diam. Drill	R. P. M.	Cutting Speed	Feed per Revolution	Feed per Minute	Cu. In. per Min.
1¾ in.	391	141 ft.	.031 in.	12.1 in.	18
2 in.	273	143 ft.	.031 in.	8.5 in.	26.7
2½ in.	154	101 ft.	.031 in.	4.8 in.	23.5
3 in.	110	87 ft.	.031 in.	3.4 in.	24

The net weight of this machine is 10,500 lb., and it requires a 7½ to 10 h.p. motor if direct motor driven.



### YOST DRAFT GEAR

The Yost lever friction draft gear, which is shown in the engravings, has been under development for several years and is now in service on about 2,000 cars. The gear is manufactured by the Hart-Otis Car Company, Limited, Montreal, Que., and is formed by placing friction levers between the followers and springs of a spring gear. It consists of four parts, the

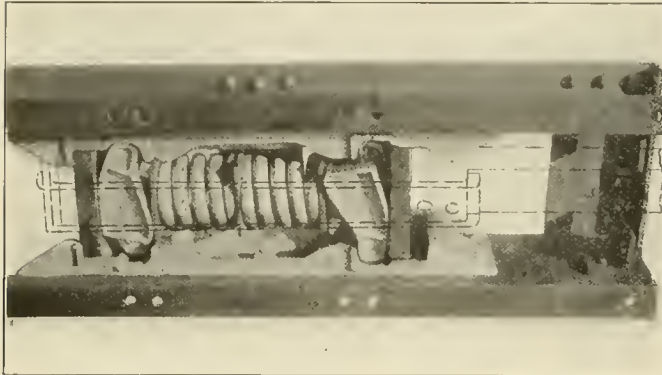

Yost Draft Gear with One Set of Levers Compressed

lugs, the levers, the springs and the followers. The springs are 6 1/4 in. by 8 in. M. C. B. standard, and the followers are the standard for spring gears.

In the operation of the gear the resistance is slight at the start of the travel and gradually increases until the full travel is

From 3/8 in. of travel, the friction levers begin to rotate, increasing from 9,800 lb. at 3/8 in. travel to 22,500 lb. at 11/16 in. of travel, which, up to this point, is the equivalent in resistance to the G spring gear. The balance of the travel is a gradually increasing resistance up to 300,000 lb. at the extreme travel. This resistance is made possible by the lever action between the coupler, draft lug and springs, together with the friction caused by the movement of these parts.

During the entire movement of the coupler, the spring compression is proportional to the travel of the friction levers and the spring cannot become solid, as it has still 1/4 in. free motion when the final travel of the coupler is reached. This, it is claimed, not only greatly increases the life of the spring, but makes the gear self-adjusting as wear takes place.

The levers are so shaped that when extreme travel is reached, all moving parts form a rigid abutment transmitting the force beyond the capacity of the draft gear to the car. The spring compression during the last 1/8 in. of coupler movement is 3/4 in.

In buffing, the blow acts directly on the draft gear through the coupler, and not on the yoke. The yoke only comes into action in pulling. This allows a free swivel movement of the yoke for any side movement of the coupler, preventing the shearing of the yoke and coupler rivets.

The levers are designed to give a leverage in compression but none in recoil. The action of the gear in recoiling is the reverse of that in compression, except that the levers being free to move bodily, have no lever action. The power returning the gear to normal position is that of the compressed spring (19,000 lb.). The spring bearing on the inner end of the levers while the outer ends are free, it is claimed, makes it impossible for the levers to stick, become displaced, or return to any posi-

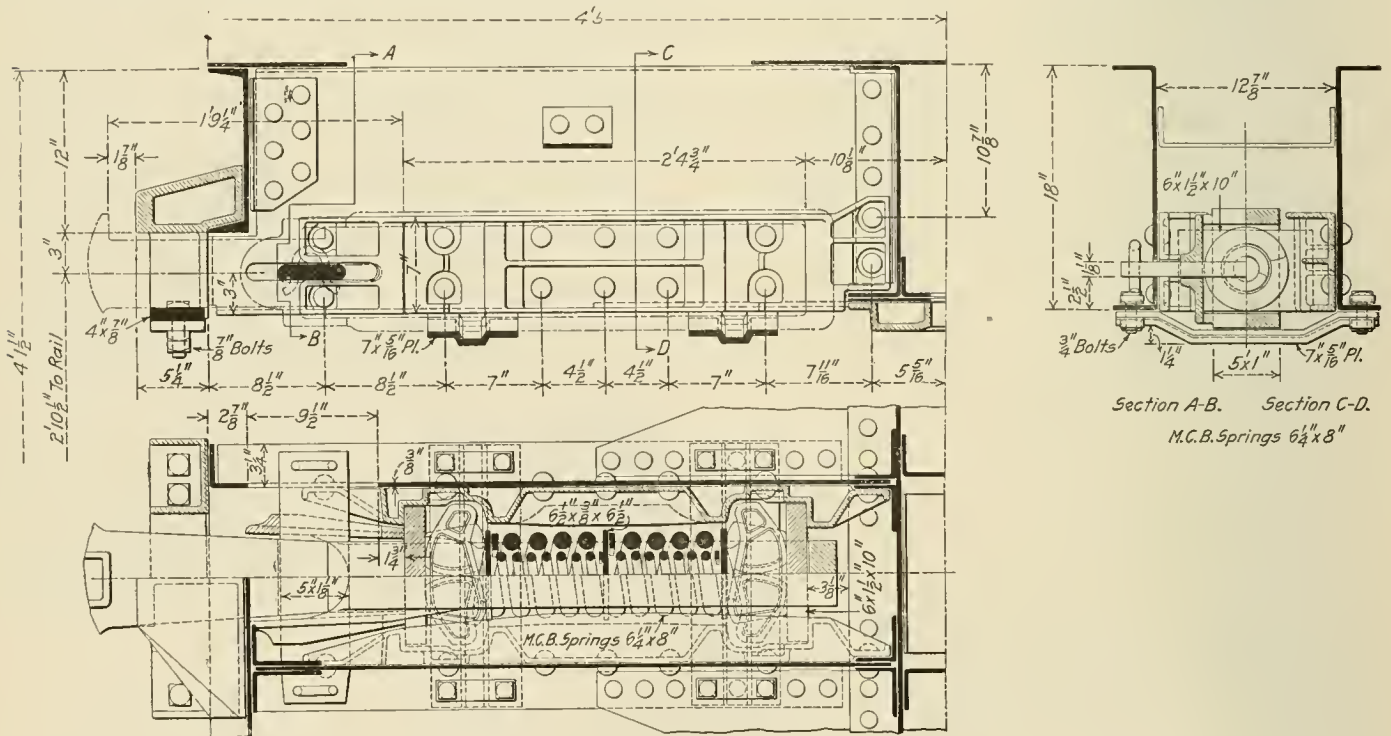

Application of Yost Draft Gear to a Steel Underframe Car

attained. The recoil is low but is sufficient to release the gear. It is claimed that the action is smooth and gradual at all points of the travel and the change from spring to spring and lever action is so gradual that it cannot be noticed. For the first 3/8 in. of travel, the friction levers move bodily, giving the spring a free action. This gives the equivalent in resistance to the old 6 1/4 in. by 8 in. spring gear to this point. The reason for making this initial travel low is to allow the engineman to start a long train without having to bunch the slack.

tion other than normal. The levers are alike for all types of the gear and are interchangeable.

COAL BRIQUETTES.—Coal briquettes to the amount of 181,859 tons, valued at \$1,007,327, were manufactured in 1913, according to Edward W. Parker, of the United States Geological Survey. Compared with 1912, there was a decrease of 17 per cent in tonnage, but an increase of 5 1/2 per cent in value.—Power.

# NEWS DEPARTMENT

The Atchison, Topeka & Santa Fe has increased the working time of its locomotive repair shops at Topeka from eight to nine hours a day. The car repair shops have also recently changed from a 48 hour week to a 54 hour week.

On Friday, May 1, the radio telegraph operators of the Delaware, Lackawanna & Western carried on telephone conversation, without wires, between Scranton and a car on an express train traveling between Scranton and Stroudsburg, a distance of about 50 miles.

The Southern Pacific reports that the accident record of the road for March was one of the best in its history. Not a single fatality, either to a passenger or an employee, occurred from the operation of trains or in industrial pursuits. The Pacific system, 6,380 miles, carried 3,079,000 passengers an aggregate distance of 102,655,000 miles in March without a single injury; and of the 43,000 employees only one was injured in an accident. The Southern Pacific has a record of having operated its entire line for five years and eight months without a fatal accident to a passenger resulting from train operation.

Marcus A. Dow, general safety agent of the New York Central lines, reports that, as a result of the vigorous campaign which has been conducted on the New York Central, the number of trespassers killed on the tracks of that company in seven months ending April 30 was 38 less than in the same period one year ago; 98 this year and 136 last year. The number of trespassers injured has also fallen off. It has been noticed that fewer persons walk on the tracks in the manufacturing districts where men and women going to and from shops have habitually walked on the railroad right of way. Mr. Dow reports a growing tendency among the judges and magistrates to punish such offenders.

The relief department of the Chicago, Burlington & Quincy has issued its twenty-fifth annual report covering the year ending December 31, 1913. The receipts for the year were \$619,958, of which \$580,388 represented contributions of members; \$20,625 income from investments, and \$18,944 cash advanced by the railroad. Benefit orders to the amount of \$616,905 were cashed by the treasurer. From June 1, 1889, to December 31, 1913, the relief department has paid out in benefit orders on account of sickness or accidents a total of \$9,451,300. The total payments by the railroad company from its own funds in establishing, operating and maintaining the relief department from 1889 to 1913, inclusive, have amounted to \$1,679,437.

On the Cleveland division of the Baltimore & Ohio, the "safety first" movement has been expanded into an efficiency movement with a gratifying degree of success; and now the superintendent, Mr. Lechluder, proposes to the employees that they go a step farther and include in their program a more intimately personal element; safety, efficiency, thrift. The Baltimore & Ohio for years has had a relief department, and in this department there is a savings bank, conducted for the benefit of all employees of the road; and it is proposed to "boost" the savings department by encouraging employees to buy for themselves homes. This department owns a house at Lorain which it will sell for \$1,900; the first payment to be \$100. Thereafter monthly instalments of \$22.50 would be paid until the whole sum is liquidated.

## CAR DEPARTMENT ORGANIZATION

The article on "Car Department Organization and Efficiency," which appeared on page 235 of our May, 1914, issue, was credited to A. Carey. It should have been published under the

name of J. H. Pitard, master car painter of the Mobile & Ohio at Whistler, Ala.

## AUTOMATIC PARCEL ROOM

The Chicago & North Western has recently placed in the waiting rooms of a number of its more important stations automatic coin-controlled parcel-checking lockers, consisting of steel cabinets of various sizes in which passengers may check their own hand baggage, taking it out of the locker as desired, without delay, by the deposit of a coin. Thus far the cabinets have been liberally patronized by the passengers.

## AIR BRAKE STORY CONTEST

A. L. Humphrey, vice-president and general manager of the Westinghouse Air Brake Company, has announced a competition for an air brake story, which is open to railway employees. Following are the conditions of this contest:

"For the best true stories illustrating the value of the Westinghouse air brake, in terms of performance and capacity, as determined by an independent committee of judges, we will make the following awards in cash:

First prize story.....	\$1,000	Fourth prize story.....	\$150
Second prize story.....	500	Fifth prize story.....	100
Third prize story.....	200	Sixth prize story.....	50

"The purpose we have in mind is to draw from the experience and practical knowledge of railroad officers and employees, striking stories of air brake performance. We know that the history of the art of braking railroad trains is rich in dramatic, but as yet unwritten narrative. On the one hand is a vast amount of such material as spectacular escape from wreck or disaster; and on the other hand a still larger—and largely unexplored—field covering the concrete evidences that efficient train control is the supreme factor in the ability to handle heavier freight and passenger traffic; and that increased tonnage, longer trains, higher speeds, etc., are simply visible demonstrations of the controlling influence of the air brake as expressed in the larger earning power possible from operation.

"Each 'story' must be written either from the practical experiences or personal observations of the writer or from information obtained at first hand from railroad men who actually know the facts. Each contestant may choose his own individual style of expression, use railroad dialect if desired, and illustrations if thought advisable. Correct names, dates, places and persons should be used so far as possible, but fictitious substitutes may be employed provided this is so stated in the transmitting letter and the fundamental facts related have actually occurred. There is no limitation as to the time when the facts given in the story may have occurred, but naturally these facts will be of larger interest if covering recent years and particularly if they apply to present standard forms of Westinghouse brake equipment. The stories will be judged primarily upon the convincing character of the narrative as to the value of the air brake; originality, striking or unusual features; accuracy of facts given; relation of the story to present day conditions; concise expression; and brevity.

"The contest is open to bona fide employees of any railroad in the United States, operating regular traffic schedules, without limitation of any kind as to age, character of work, education, or other qualification.

"No 'story' shall be more than two thousand words in length. Manuscripts exceeding two thousand words will not be considered in the competition. Each 'story' should be



written on one side of the sheet only and preferably typewritten. Neither name, address, nor other means of identification should be shown except in the transmitting letter.

"No expense is involved in entering this contest, but it is understood that all narratives submitted become the property of the Westinghouse Air Brake Company whether securing an award or otherwise.

"Decision as to merits of the stories submitted will be placed absolutely in the hands of a committee of judges composed of three prominent persons not associated in any way with the Westinghouse interests.

"Each 'story' should be addressed to the 'Judges of Prize Contest,' room 2121, 165 Broadway, New York, N. Y. When received and serially numbered, the manuscripts, without name or other identification, will be turned over to the committee of judges by a disinterested party appointed by and acting for the committee, and who will retain the transmitting letters after making careful record thereon of the serial number of the manuscript. The judges will, therefore, pass upon the manuscript submitted without knowing by whom written until after the award is made.

"All stories to be considered in this competition must be in the hands of the committee on or before August 1, 1914. Announcement of awards by the committee of judges will be made as promptly as possible thereafter."

#### MEETINGS AND CONVENTIONS

*Cornell Alumni at Atlantic City.*—Professor Dexter S. Kimball, of Cornell University, will be the guest of honor at the ninth annual dinner of the Cornell alumni, who will attend the Master Car Builders' and Master Mechanics' conventions at Atlantic City. The dinner will be held on the closing day of the Master Car Builders' convention, Friday, June 12.

*American Society for Testing Materials.*—The seventeenth annual meeting of the American Society for Testing Materials will be held at the Hotel Traymore, Atlantic City, N. J., June 30-July 3. The program is divided into sessions on non-ferrous materials, steel, cement and concrete, lime, ceramics and road materials, preservative coatings and testing apparatus.

*International Railroad Master Blacksmiths' Association.*—The following are the subjects to be considered at the convention to be held in Milwaukee, Wis., August 18 to 20, 1914: Flue Welding; Making and Repairing Frogs and Crossings; Carbon or High Speed Steel; Tools; Electric Welding; Drop Forging; Spring Making and Repairing; Piece Work and Other Methods; Locomotive Frame Making and Repairing; Oxy-Acetylene Cutting and Welding; Case Hardening; Heat Treatment of Metals, and Shop Kinks.

*International Railway General Foremen's Association.*—In order to build up the membership of the International Railway General Foremen's Association, the secretary has sent out letters to general foremen throughout the country urging them to become members and also to superintendents of motive power calling their attention to the aims of the association and to the character of the work which it has accomplished in the past. The secretary states that the association is a business proposition and asks the motive power officers to inform their general foremen that if they become members and attend the conventions the time will not be deducted from their vacation period.

*Canadian Railway Club.*—At its meeting in Montreal, on May 12, the Canadian Railway Club elected officers for the ensuing year as follows: President, William McNab, principal assistant engineer, Grand Trunk; first vice-president, L. C. Ord, assistant master car builder, Eastern lines, Canadian Pacific; second vice-president, R. M. Hannaford, assistant chief engineer, Montreal Tramways; secretary, James Powell, Grand Trunk; treasurer, W. H. Stewart, Canadian Pacific. The report of the secretary shows an increase in membership during the past year, and that

of the treasurer shows a balance in the treasury of over \$3,000. The club has been incorporated under the laws of Quebec.

*Western Railway Club.*—At the annual meeting of the Western Railway Club in Chicago the following members were elected as officers for the ensuing year: W. E. Pratt, Chicago & North Western, president; H. H. Harvey, Chicago, Burlington & Quincy, first vice-president; J. H. Tinker, Chicago & Eastern Illinois, second vice-president; Joseph W. Taylor, secretary-treasurer. The following were elected to the board of directors: J. M. Borrowdale, Illinois Central; W. E. Dunham, Chicago & North Western; A. R. Kipp, Minneapolis, St. Paul & Sault Ste. Marie. The following were elected library trustees: H. T. Bentley, Chicago & North Western; W. E. Sharp, Grip Nut Company; Dr. W. F. M. Goss, University of Illinois.

*Traveling Engineers' Association.*—The twenty-second annual convention will be held at the Hotel Sherman, Chicago, Ill., commencing at 10 a. m., Tuesday, September 15, and continuing four days. Special rates have been arranged at the hotel, and in anticipation of this being the largest convention yet held, the secretary urges on members the necessity of making reservations in ample time. The subjects to be discussed this year are as follows:

Difficulties accompanying prevention of dense black smoke and its relation to cost of fuel and locomotive repairs; Martin Whalen, chairman. Operation of all locomotives with a view of obtaining maximum efficiency at lowest cost; J. R. Scott, chairman. Advantage to be derived from the use of mechanical stokers, considering (first) increased efficiency of the locomotive; (second) increasing the possibility of securing a higher type of candidates for the position of firemen; (third) the utilization of cheaper grades of fuel; J. H. DeSalis, chairman. The care of locomotive brake equipment on line of road and at terminals; also, methods of locating and reporting defects; Geo. H. Wood, chairman. Advantage derived from the use of speed recorders and their influence on operating expense; Fred Kerby, chairman. Practical chemistry of combustion; A. G. Kinyon. Scientific train loading; tonnage rating; the best method to obtain maximum tonnage haul for the engine over the entire division, taking into consideration the grades at different points on the division; O. S. Beyer, Jr.

*The following list gives names of secretaries, dates of next or regular meetings, and places of meeting of mechanical associations.*

- AIR BRAKE ASSOCIATION.—F. M. Nellis, 53 State St., Boston, Mass.  
 AMERICAN RAILWAY MASTER MECHANICS' ASSOC.—J. W. Taylor, Karpen building, Chicago. Convention, June 15-17, 1914, Atlantic City, N. J.  
 AMERICAN RAILWAY TOOL FOREMEN'S ASSOCIATION.—A. R. Davis, Central of Georgia, Macon, Ga. Convention, July 20-22, 1914, Hotel Sherman, Chicago.  
 AMERICAN SOCIETY FOR TESTING MATERIALS.—Prof. E. Marburg, University of Pennsylvania, Philadelphia, Pa. Convention, June 30-July 4, Hotel Traymore, Atlantic City, N. J.  
 AMERICAN SOCIETY OF MECHANICAL ENGINEERS.—Calvin W. Rice, 29 W. Thirty-ninth St., New York. Convention, June 16-19, St. Paul-Minneapolis, Minn.  
 CAR FOREMEN'S ASSOCIATION OF CHICAGO.—Aaron Kline, 841 North Fiftheth Court, Chicago; 2d Monday in month, except July and August, Lytton building, Chicago.  
 CHIEF INTERCHANGE CAR INSPECTORS' AND CAR FOREMEN'S ASSOCIATION.—S. Skidmore, 946 Richmond street, Cincinnati, Ohio. Convention, August 25-27, 1914, Cincinnati, Ohio.  
 INTERNATIONAL RAILWAY FUEL ASSOCIATION.—C. G. Hall, 922 McCormick building, Chicago.  
 INTERNATIONAL RAILWAY GENERAL FOREMEN'S ASSOCIATION.—William Hall, 829 W. Broadway, Winona, Minn. Convention, July 14-17, 1914, Hotel Sherman, Chicago.  
 INTERNATIONAL RAILROAD MASTER BLACKSMITHS' ASSOCIATION.—A. L. Woodworth, Lima, Ohio. Convention, August 18-20, 1914, Milwaukee, Wis.  
 MASTER BOILER MAKERS' ASSOCIATION.—Harry D. Vought, 95 Liberty St., New York.  
 MASTER CAR BUILDERS' ASSOCIATION.—J. W. Taylor, Karpen building, Chicago. Convention, June 10-12, 1914, Atlantic City, N. J.  
 MASTER CAR AND LOCOMOTIVE PAINTERS' ASSOC. OF U. S. AND CANADA.—A. P. Dape, B. & M., Reading, Mass. Convention, September 8-11, 1914, Nashville, Tenn.  
 NIAGARA FRONTIER CAR MEN'S ASSOCIATION.—E. Frankenberg, 623 Brisbane building, Buffalo, N. Y. Meetings monthly.  
 RAILWAY STOREKEEPERS' ASSOCIATION.—J. P. Murphy, Box C, Collinwood, Ohio.  
 TRAVELING ENGINEERS' ASSOCIATION.—W. O. Thompson, N. Y. C. & H. R., East Buffalo, N. Y. Convention, September 15, 16, 17 and 18, 1914, Hotel Sherman, Chicago, Ill.

## PERSONALS

*It is our desire to make these columns cover as completely as possible all the changes that take place in the mechanical departments of the railways of this country, and we shall greatly appreciate any assistance that our readers may give us in helping to bring this about.*

### GENERAL

A. C. ADAMS has been appointed superintendent of motive power of the United Railway, with headquarters at Portland, Ore.

H. COCKFIELD has resigned as locomotive superintendent of the Entre Rios Railways at Parana, Argentine.

A. C. HINCKLEY has been appointed superintendent of motive power and machinery of the Oregon Short Line, with headquarters at Salt Lake City, Utah. Mr. Hinckley was born in New York in 1863. He passed through the grammar school and attended Meads College for two years, beginning railway work about 1885 with the Chicago, Pekin & Southwestern, with which road he remained for six years as apprentice and machinist. He was then for three years locomotive engineer on the Chicago, Burlington & Northern out of LaCrosse, Wis., and subsequently was for three years with the Utah Central as road foreman of engines and master mechanic at Salt Lake City, Utah; master mechanic of the Denver &



A. C. Hinckley

Rio Grande at Salida, Colo., for three years; and in charge of the mechanical and car departments of the Cincinnati, Hamilton & Dayton at Lima, Ohio, for four and a half years. Mr. Hinckley went to the Southern Pacific in January, 1910, as master mechanic at West Oakland, Cal., which position he resigned to become superintendent of motive power and machinery of the Oregon Short Line, on May 1.

L. A. RICHARDSON, mechanical superintendent of the third district of the Chicago, Rock Island & Pacific at El Reno, Okla., has been transferred to Des Moines, Iowa, as mechanical superintendent of the first district, succeeding H. C. Van Buskirk, resigned.

J. C. NOLAN, master mechanic of the St. Louis, Brownsville & Mexico, has been appointed superintendent at Kingsville, Tex., succeeding R. F. Carr.

R. L. STEWART has been appointed mechanical superintendent of the Rock Island Lines at El Reno, Okla., succeeding L. A. Richardson, transferred.

### MASTER MECHANICS AND ROAD FOREMEN OF ENGINES

A. H. BINNS has been appointed district master mechanic of the Ontario division of the Canadian Pacific at West Toronto, Ont., succeeding L. F. Hamilton.

W. W. BOLINEAU has been appointed road foreman of engines of the Central of Georgia at Macon, Ga.

J. J. CAREY, master mechanic of the Baltimore & Ohio South-

western at Washington, Ind., has been appointed master mechanic of the Texas & Pacific at Marshall, Tex., succeeding G. H. Langton, resigned.

H. A. CRANCE has been appointed road foreman of engines of the Chicago, Burlington & Quincy at Brookfield, Mo., succeeding C. E. Lowe.

P. J. COLLIGAN has been appointed master mechanic of the Illinois division of the Rock Island Lines at Chicago, Ill., succeeding R. L. Stewart, promoted.

JOHN DICKSON, general master mechanic of the Spokane, Portland & Seattle and the Oregon Trunk, at Portland, Ore., has had his jurisdiction extended over the Spokane & Inland Empire.

A. H. FIRNHABER has been appointed master mechanic of the New Iberia & Northern at New Iberia, La.

C. E. FOWLER has been appointed master mechanic of the Jefferson & North Western at Jefferson, Tex.

W. GRAFF has been appointed road foreman of engines of the Baltimore & Ohio Southwestern at Chillicothe, Ohio.

JOHN HALLMAN has been appointed master mechanic of the North Louisiana & Gulf at Hodge, La., succeeding G. H. Huntley.

F. A. HAMM has been appointed master mechanic of the Staten Island Rapid Transit at Clifton, N. Y.

F. HEINS has been appointed master mechanic of the Gulf & Sabine River at Fullerton, La.

M. P. HOBMAN has been appointed road foreman of engines of the Baltimore & Ohio at Dayton, Ohio.

W. T. LOVELL has been appointed master mechanic of the Oregon-Washington Railroad & Navigation Company, with headquarters at Portland, Ore., succeeding James Healy, resigned.

J. T. LUSCOMBE has been appointed master mechanic of the Ohio River division of the Baltimore & Ohio, with office at Parkersburg, W. Va. Mr. Luscombe was born on June 29, 1874, at Queenstown, Cork county, Ireland. After a high school education at Belleville, Ont., he began railway work in 1891 with the Grand Trunk at that place. During the ten years from 1891 to 1901 he was with a number of roads as machinist, and also studied in the Scranton schools. In May, 1901, he was made general foreman of the Baltimore & Ohio at Uhrichsville, Ohio, and was later transferred to Newark, Ohio, as machine shop foreman. In 1905 he went with the Chicago & Alton as machine shop foreman at Bloomington, Ill., and in September, 1907, became general foreman of the Toledo & Ohio Central at Bucyrus, Ohio. In March, 1908, he was promoted to master mechanic, and four years later was appointed master mechanic of the Cleveland, Cincinnati, Chicago & St. Louis, with office at Bellefontaine, Ohio. He resigned from that position in October, 1913, to go to the National Boiler Washing Company, Chicago, and now returns to railway work as master mechanic of the Ohio River division of the Baltimore & Ohio, as above noted.

T. McCLAIN has been appointed master mechanic of the Arkansas, Louisiana & Gulf at Monroe, La., succeeding W. L. Essex.

A. E. McMILLAN has been appointed assistant master mechanic of the Baltimore & Ohio Southwestern at Cincinnati, Ohio.

F. W. MURPHY has been appointed master mechanic of the Chicago, Ottawa & Peoria at Ottawa, Ill.

A. PEERS has been appointed district master mechanic of the Canadian Pacific in charge of the Winnipeg, Man., terminals.

B. D. RICHARDSON has been appointed master mechanic of the Midland Valley at Muskogee, Okla., succeeding James Carr.



R. E. ROWE, roundhouse foreman of the St. Louis, Brownsville & Mexico, has been appointed master mechanic at Kingsville, Tex., succeeding J. C. Nolan, promoted.

J. A. SHEPPARD has been appointed master mechanic on the Missouri Pacific at Coffeyville, Kan., succeeding G. K. Stewart, transferred.

P. SMITH has been appointed road foreman of equipment of the Rock Island Lines at Chicago, Ill., succeeding Wm. Germer.

OSCAR STEVENS has been appointed road foreman of engines of the Baltimore & Ohio Southwestern at Cincinnati, Ohio.

G. K. STEWART, master mechanic of the Missouri Pacific at Coffeyville, Kan., has been transferred to De Soto, Mo.

W. M. WILSON has been appointed master mechanic of the Mexico division of the Rock Island Lines at Dalhart, Tex., succeeding P. J. Colligan, transferred.

#### CAR DEPARTMENT

G. M. ARGUE has been appointed car foreman of the Canadian Northern at Fort Francis, Ont., succeeding E. W. Winnebeck, resigned.

J. P. BRENDL has been appointed general foreman of the car shops of the Southern Pacific at Sacramento, Cal.

H. C. GRIFFIN has been appointed general car inspector of the Canadian Pacific, Eastern lines, with headquarters at Montreal, Que., succeeding L. C. Ord, promoted.

F. HEIM has been appointed master car builder of the Midland Continental at Jamestown, N. D., succeeding E. J. Hazelton.

W. A. MARTIN has been appointed general car foreman of the Bangor & Aroostook at Milo Junction, Maine.

T. M. RAMSDALL, master car builder of the Chicago & Alton, has been appointed master car builder of the Oregon-Washington Railroad & Navigation Company at Albina shops, Portland, Oregon.

A. L. TETU has been appointed car foreman of the Great Northern at Cass Lake, Minn., succeeding J. Becker.

#### SHOP AND ENGINE HOUSE

J. AITKEN has been appointed locomotive foreman of the Canadian Pacific at Sherbrooke, Que., succeeding C. W. Stackhouse.

F. A. BLADORN has been appointed locomotive foreman of the Great Northern at Billings, Mont.

G. BRIMACOMBE has been appointed locomotive foreman of the Canadian Pacific at Sortin Yard, Montreal, Que.

L. CLEARY has been appointed assistant locomotive foreman of the Canadian Pacific at Outremont, Que.

J. G. COSTELLO has been appointed general foreman of the Denver, Laramie & Northwestern at Denver, Colo.

G. F. DENNE has been appointed foreman painter of the New York, Chicago & St. Louis at Chicago, succeeding C. Clark.

G. DROLET has been appointed general engine foreman of the Bangor & Aroostook at Milo Junction, Maine.

F. FISHER has been appointed general foreman of the Chicago, Peoria & St. Louis at Springfield, Ill.

W. F. GALLUP has been appointed general foreman of the Atchison, Topeka & Santa Fe at Raton, N. M., succeeding I. H. Drake.

HENRY GARDNER, assistant superintendent of shops of the Baltimore & Ohio at Mt. Clare, Baltimore, Md., was a special apprentice with the Boston & Maine from 1896 to 1899, and not superintendent of apprentices as stated in the May issue.

R. J. GREINER has been appointed general foreman of the Mis-

souri, Kansas & Texas at Smithville, Tex., succeeding Max Chase, resigned.

J. B. HARVARD has been appointed general foreman of the Baltimore & Ohio Southwestern at Flora, Ill.

R. D. HUTCHINGS has been appointed roundhouse foreman of the Southern at Selma, Ala., succeeding G. W. Thomas, resigned on account of ill health.

F. KUBECK has been appointed shop foreman of the Chicago & North Western at Green Bay, Wis., succeeding C. H. Matthews.

THOMAS LONG has been appointed roundhouse foreman of the St. Louis & San Francisco at Harwood, Ark.

A. D. McCHARLES has been appointed locomotive foreman of the Great Northern at Havre, Mont., succeeding F. W. Ramer.

EDWARD McCUE has been appointed roundhouse foreman of the Erie at Ferrona, Pa., succeeding R. Edwards, transferred.

C. McLEAN has been appointed locomotive foreman of the Chicago Great Western at Oelwein, Iowa, succeeding H. Brinkman.

A. J. MAITLAND has been appointed locomotive foreman of the Canadian Pacific at Ignace, Ont., succeeding H. J. Reid, transferred.

F. M. MARELY has been appointed roundhouse foreman of the Texas & Gulf (Gulf, Colorado & Santa Fe) at Longview, Tex.

W. P. MILON has been appointed locomotive foreman of the Great Northern at Whitefish, Mont.

B. J. PEASELY has been appointed superintendent of shops of the Missouri Pacific at Argenta, Ark.

D. P. PHALEN has been appointed locomotive foreman of the Great Northern at Butte, Mont.

F. A. PHILLIPS has been appointed locomotive foreman of the Great Northern at Great Falls, Mont., succeeding R. Lloyd.

L. J. POOLE has been appointed assistant boilershop foreman of the Erie at Meadville, Pa., succeeding William Williams, transferred.

G. PRATT has been appointed locomotive foreman of the Canadian Pacific at Souris, Man., succeeding A. Peers, promoted.

THOMAS PURCELL, boiler foreman of the Atchison, Topeka & Santa Fe Coast Lines at Winslow, Ariz., has been transferred to Richmond, Cal., as boiler foreman at that point.

H. J. REID has been appointed assistant locomotive foreman of the Canadian Pacific at Souris, Man., succeeding G. Pratt, promoted.

C. E. SARNEY has been appointed locomotive foreman of the Canadian Pacific at Megantic, Que.

O. B. SCHÖENKY has been appointed shop superintendent of the Southern Pacific at Sacramento, Cal.

D. S. WATKINS has been appointed shop superintendent of the Southern Pacific at Sacramento, Cal.

JAMES WEIR has been appointed night locomotive foreman of the Canadian Pacific at Outremont, Que.

#### PURCHASING AND STOREKEEPING

W. R. DAWSON has been appointed storekeeper of the Toledo division of the Baltimore & Ohio at Dayton, Ohio, succeeding T. H. Baker.

F. A. FITZGERALD has been appointed storekeeper of the Baltimore & Ohio at Washington, Ind., succeeding H. P. McQuilkin, promoted.

O. V. McQUILKIN has been appointed storekeeper of the Baltimore & Ohio at Glenwood, Pa., succeeding E. W. Thornley, promoted.

## SUPPLY TRADE NOTES

Leman D. Doty, for 23 years purchasing agent for the Illinois Steel Company, died on May 24 at his home in Chicago.

Victor J. Shepard, for the past ten years chief draftsman of the Lima Locomotive Corporation, Lima, Ohio, has resigned.

The Welding Materials Company, New York, has moved its office from 149 Broadway to the Engineering building, 114 Liberty street.

The Chicago-Cleveland Car Roofing Company has removed its Chicago office from the Peoples Gas building to 535 Railway Exchange.

C. P. Williams, recently of the National Lock Washer Company, has become connected with The Efficiency Company, Railway Exchange, Chicago.

E. H. Barnes, southern representative of S. F. Bowser & Company, Inc., Fort Wayne, Ind., has severed his connection with that company, effective May 15.

The Chicago office of the Falls Hollow Staybolt Company, formerly in the Old Colony building, is now located in the Fisher building, 343 S. Dearborn street.

The offices of Paul Dickinson, Inc., have been moved from the Security building to 3346 South Artesian avenue, Chicago, and has discontinued its downtown office.

The Carbo Steel Post Company, Inc., has enlarged its offices in the Rand McNally building, 538 South Clark street, Chicago, and now occupies rooms 881 to 887.

Flint & Chester, Inc., New York, have been appointed selling agents for the National Graphite Lubricator Company, Scranton, Pa., for the East, including the railroads in the territory north and east of Buffalo and Baltimore.

George M. Black, treasurer of the Detroit Seamless Steel Tubes Company and the Monarch Steel Castings Company, and secretary of the Michigan Malleable Iron Company, all of Detroit, Mich., died in that city on May 5.

The Chicago agency of the Industrial Works, Bay City, Mich., formerly with Mudge & Co., has been discontinued. For the present the Chicago territory will be handled from the main office in Bay City, but in the near future a sales office will be opened in Chicago under the name of the Industrial Works.

Colonel Harlow D. Savage, general eastern sales manager of the American Arch Company, 30 Church street, New York, has been elected vice-president of that company. A photograph, and a sketch of Colonel Savage's career were published in the April issue of the Railway Age Gazette, Mechanical Edition, page 218.

Louis H. Burns, who was formerly connected with the office of the motive power department of the Chicago, Rock Island & Pacific, has been appointed western representative of the injector department of William Sellers & Company, Inc., Philadelphia. His office will be on the ninth floor of the Lytton building, Chicago.

F. N. Kollock, Jr., formerly district manager of the Seattle office of the Westinghouse Electric & Manufacturing Company, has resigned his position to become treasurer and assistant secretary of the Westinghouse Lamp Company, Bloomfield, N. J. He has been succeeded by W. D. McDonald, formerly branch manager of the Minneapolis office. C. C. Curry has been appointed acting branch manager of the latter office.

W. Sharon Humes, for the past five years sales manager of the General Railway Supply Company, Chicago, has been retained by the Transportation Utilities Company, New

York, which company acquired the entire business of the General Railway Supply Company on April 15. Mr. Humes' office will be in Chicago, as heretofore; and he will represent the new company in all of the territory west of Pittsburgh.

Alexander B. Scully, president of the Scully Steel & Iron Company, died on May 7 at his home in Chicago. Mr. Scully was born in Chicago on November 29, 1856, and after attending the public schools, began his business career as a messenger boy. In 1875 he entered the employ of Joseph T. Ryerson, where he remained until 1885. In 1886 he formed the W. F. Mallory Company, which firm sold out to Joseph T. Ryerson & Son in 1890. In 1891 he formed the Scully-Castle Company, which later became the Scully Steel & Iron Company, of which he was president up to the time of his death.

F. W. Coolbaugh, widely known in the railway supply trade, died on Saturday morning, May 16, at his home in Philadelphia, Mr. Coolbaugh was born at Stroudsburg, Pa., on August 21, 1848. At the age of 12 he entered the employ of the Delaware, Lackawanna & Western Railroad as water boy on a gravel train. He later became telegraph operator and was subsequently chief dispatcher at Hoboken. In 1882 he entered the railway supply field as a salesman for Armour & Osterhaut, manufacturers of railway lanterns. He later became senior member of the firm of Coolbaugh, McMunn & Pomeroy, general sales agents in New York and the east for Carnegie, Phipps & Company; the Cambria Steel Company; the Boies Steel Wheel Company; the Lukens Iron & Steel Company, and the Latrobe Steel Company. In 1895, he purchased the patent rights of the Marden brake beam, and established the Sterlingworth Railway Supply Company at Easton, Pa., where from 1896 to 1902 the beam was manufactured and applied to nearly half a million cars. He continued in malleable iron and rolling mill work until 1907, when he moved to Philadelphia as president of the Acme Railway Equipment Company, in the manufacture and sale of their uncoupling device.

Richard F. Spamer has been appointed general manager of the Stentor Electric Manufacturing Company, Inc., New York, a recently-formed company which is now taking over



R. F. Spamer

the business of the Electrical Experiment Company of the same city. Mr. Spamer was born in St. Louis on March 29, 1878. He entered the employ of the Bell Telephone Company of Missouri in 1895, and worked in the inspection and traffic departments of that company until 1903. In that year he became superintendent of plant of the Consolidated Fire Alarm Company, Chicago, and while holding that position developed and patented an automatic sprinkler supervisory system and various other kinds of

fire alarm equipment. In 1907 he entered the employ of the Western Electric Company and was connected with that company's New York office as railway telephone engineer at the time of his appointment to his present position. While he was in the employ of the company, also, he developed and patented a number of appliances used in telephone train despatching.



## CATALOGS

**ELECTRIC HOISTS.**—A 32-page catalog issued by the Sprague Electric Company, New York, is devoted to the electric hoists manufactured by that company. A number of tables are included giving ratings, capacities and weights.

**ELECTRIC FANS.**—A 30 page booklet issued by the Sprague Electric Works, 527 West Thirty-fourth street, New York, is descriptive of the various types of electric fans manufactured by that company. The booklet includes specifications.

**HYDRO VOLUME & PRESSURE RECORDERS.**—Catalog B, from Herman Bacharach, 14 Wood street, Pittsburgh, Pa., contains considerable information and a number of charts which will prove valuable in making measurements of the flow and pressure of gas.

**ELECTRIC DRILLS.**—A leaflet just issued by the Independent Pneumatic Tool Company, Chicago, Ill., describes the Thor electric drill. These drills are portable and are equipped throughout with ball and roller bearings. The leaflet includes specifications.

**NUT TAPPING MACHINES.**—The National Machinery Company, Tiffin, Ohio, has issued circular No. 1010-B describing the National 1 in. six spindle semi-automatic nut tapper. This machine is furnished for either belt or direct motor drive, and is also built in a 1½ in. size with ten spindles.

**ELECTRIC HOISTS.**—Catalog D 1914, of the Brown Hoisting Machinery Company, Cleveland, Ohio, is devoted to the Brown-hoist, tramrail systems, trolleys and electric hoists. The book contains 64 pages, and has a number of illustrations and a great deal of information pertaining to these systems.

**MOTORS AND GENERATORS.**—Fairbanks-Morse & Company, Chicago, Ill., have recently issued bulletins 27 and 29, dealing with direct current type motors and generators. Bulletin No. 210 from the same company is descriptive of Fairbanks-Morse inter-natal starter motors. These bulletins are all thoroughly illustrated.

**INDUCTION MOTORS.**—Bulletin No. 202-H from Fairbanks-Morse & Company, Chicago, Ill., describes that company's alternating current type B constant speed induction motors. The bulletin contains 20 pages, and is very completely illustrated, as well as giving a great deal of information pertaining to these motors.

**BORING AND DRILLING MACHINES.**—Catalog No. 2614 from the Betts Machine Company, Wilmington, Del., considers the horizontal boring and drilling machines and attachments manufactured by that company. The catalog contains 20 pages and has a number of good illustrations of the different sizes of the machine.

**FLANGE LUBRICATORS.**—A 12-page pamphlet issued by the Detroit Lubricator Company, Detroit, Mich., describes and illustrates the Detroit Automatic Flange Lubricator. Besides illustrations of the lubricator, diagrams are included showing the way in which the device should be located on various types of locomotives.

**HESS-BRIGHT BALL BEARING HANGERS.**—A booklet issued by the Hess-Bright Manufacturing Company, Front street and Erie avenue, Philadelphia, gives descriptive matter with price list and dimensions of ball bearing shaft hangers and stands. The booklet also includes statements of power savings with these hangers as shown in tests.

**LOCOMOTIVE SANDERS.**—Bulletin No. 97, from Harry Vissering & Co., Chicago, Ill., contains 33 pages and deals with the various railway supplies manufactured by that company. These include, besides the Viloco locomotive sanders, Leach sanders, bell ringers, blower valves, metallic packing, sand driers, flexible sand pipe and brake steps.

**DIRECT CURRENT MOTORS.**—Bulletin No. 41010, recently issued

by the Sprague Electric Works, 527 West Thirty-fourth street, New York, is devoted to types C and D direct current motors manufactured by that company. Considerable descriptive matter is included, as well as a number of illustrations showing these motors in service.

**AIR COMPRESSORS.**—The Laidlaw-Dunn-Gordon Company, Cincinnati, Ohio, has recently issued bulletin L-523-A describing the Cincinnati gear duplex Corliss steam driven air compressors, classes WA and XA. This bulletin contains 24 pages and has a number of illustrations and tables giving the various dimensions of the different compressors.

**AUTOMATIC HEAT CONTROLLER.**—This is the subject of an illustrated booklet issued by the American Gas Furnace Company, 24 John street, New York. The instrument described is the invention of George F. Machlet, of that company, and it is claimed that it automatically controls temperatures to within 5 deg. Fahrenheit, thus providing a self-regulating gas furnace.

**ELEVATORS.**—The Whiting Foundry Equipment Company, Harvey, Ill., has issued catalog No. 109, superseding No. 91, which is descriptive of the elevators manufactured by that company. These include elevators of the compressed air and hydro-pneumatic types, as well as electric elevators and hoisting machines. The catalog gives complete data pertaining to these various types.

**HYDRAULIC JACKS.**—A 90 page catalog issued by the Watson-Stillman Company, New York, deals with the hydraulic jacks and lifting tools manufactured by that company. This is known as sectional catalog No. 91, and supersedes catalogs Nos. 66, 68 and the jack section of No. 82. The catalog, besides describing the various hydraulic jacks, gives lists of repair parts and directions concerning the use of such jacks.

**ELECTRICAL INSTRUMENTS.**—Bulletin No. 104, issued by the Wagner Electric Manufacturing Company, St. Louis, Mo., besides describing the different types of Wagner portable electrical instruments is intended as a manual of electrical testing. The book contains 48 pages and deals with a large number of electrical tests with diagrams included to show the various connections and the locations of the instruments.

**LOGGING LOCOMOTIVES.**—Record No. 76, published by the Baldwin Locomotive Works, Philadelphia, deals with the logging locomotives for narrow and standard gage built by that company. These locomotives range from a 3 ft. gage, Forney type, with a total weight of 31,700 lb., to a Mikado type for standard gage track, weighing 174,600 lb. Several of the engines included in the description are designed for burning wood, and a great many of them are of the double end type. Several pages are also devoted to geared truck locomotives, and the illustrations bring out the construction of this type very clearly.

**TWIST DRILLS, THEIR USES AND ABUSES.**—This is the title of a small booklet which has been published by The Cleveland Twist Drill Company, Cleveland, Ohio. After an interesting discussion of the theory and design of the twist drill, a considerable part of the booklet is devoted to a discussion of experiments with drills of various shapes. This includes torsion and feed pressure charts, and discusses the difference in the shape of the groove, the form of chip as an index to a proper working drill, the effect of the angle of the point on the feed pressure, how the point should be ground, the importance of having the cutting edges at equal angles and of equal length, the importance of lip clearance, the cause of chipped cutting edges, the angle of lip clearance and the angle of the spiral. Several pages are devoted to drilling "helps and hints." Records of remarkable results which were obtained from a test of the Cleveland drill at the Atlantic City conventions in June, 1911, are discussed, and the booklet closes with a table of the revolutions per minute to secure different cutting speeds for various diameters of drills.

# Railway Age Gazette

MECHANICAL EDITION

INCLUDING THE  
AMERICAN ENGINEER

PUBLISHED ON THE FIRST THURSDAY OF EVERY MONTH BY THE  
SIMMONS-BOARDMAN PUBLISHING COMPANY,  
WOOLWORTH BUILDING, NEW YORK, N. Y.

CHICAGO: Transportation Bldg. CLEVELAND: Citizen's Bldg.  
LONDON: Queen Anne's Chambers, Westminster.

EDWARD A. SIMMONS, *President* L. B. SHERMAN, *Vice-President*  
HENRY LEE, *Secretary*

The address of the company is the address of the officers.

ROY V. WRIGHT, *Editor*

R. E. THAYER, *Associate Editor* C. B. PECK, *Associate Editor*

A. C. LOUDON, *Associate Editor* GEORGE L. FOWLER, *Associate Editor*

Subscriptions, including the eight daily editions of the *Railway Age Gazette* published in June in connection with the annual conventions of the Master Car Builders' and American Railway Master Mechanics' Associations, payable in advance and postage free:

United States, Canada and Mexico.....	\$2.00 a year
Foreign Countries (excepting daily editions)....	3.00 a year
Single Copy .....	20 cents

Entered at the Post Office at New York, N. Y., as mail matter of the second class.

WE GUARANTEE, that of this issue 4,150 copies were printed; that of these 4,150 copies, 3,650 were mailed to regular paid subscribers, 150 were provided for counter and news companies' sales, 271 were mailed to advertisers, exchanges and correspondents, and 79 were provided for samples and office use; that the total copies printed this year to date were 30,150, an average of 4,307 copies a month.

VOLUME 88 JULY, 1914 NUMBER 7

## CONTENTS

EDITORIALS:	
Draft Gear Competition Prize Winner.....	339
Interchange Inspectors' Convention.....	339
July Mechanical Conventions.....	339
Competition on Engine House Work.....	340
More Information Wanted About Draft Gear.....	340
The Draft Gear Problem.....	340
New Books .....	341
COMMUNICATIONS:	
Encourage Employees to Study.....	342
Boring Eccentric Straps.....	342
GENERAL:	
Pennsylvania Mikado Type Locomotive.....	343
Maximum Permissible Error in Crank Pin Location.....	348
Modern Locomotive Coaling Station.....	349
Typical Examples of Recent Locomotives.....	350
Locomotive Tool Equipment.....	352
Economies in Roundhouse and Terminal Fuel Consumption.....	355
Elliptic Spring Tables.....	356
Rolling Stock on Curves.....	357
CAR DEPARTMENT:	
Steel Truck with Clasp Brake Rigging.....	359
Defective Box Cars.....	360
Draft Gear Problem—Suggested Remedies.....	361
Dairy Refrigerator Car.....	367
Packing and Lubricating Journals.....	369
Steel Steps for Passenger Cars.....	370
SHOP PRACTICE:	
Hot Water Boiler Washing System.....	371
Observations on Apprentice Schools.....	373
Repairing Air Pump Governors.....	373
Testing Car Roofs for Leakage.....	374
Spring Rigging and Tire Repairs.....	374
Reclaiming Cast Steel Driving Boxes.....	375
Crown Sheet Expansion Stays.....	375
Check Nut for Hose Connections.....	377
Device for Bending Meat Hooks.....	378
Portable Combination Test Rack.....	378
Chuck for Eccentrics.....	379
Emery Wheel Stand.....	380
Clips for Holding Brake Cylinder Head Gaskets.....	380
NEW DEVICES:	
Grinding Wheel Stand.....	381
Austin Trailing Truck.....	382
Automatic Flange Lubricator.....	383
Direct Oil Driven Air Compressor.....	383
Heavy Duplex Milling Machine.....	384
Frictionless Return Roller Side Bearing.....	384
Pneumatic Press for General Work.....	385
Vertical Shaper .....	385
Car Closet .....	386
NEWS DEPARTMENT:	
Notes .....	387
Meetings and Conventions.....	388
Personals .....	389
Supply Trade Notes.....	391
New Shops .....	391
Catalogs .....	392

### Draft Gear Competition Prize Winner

Sixteen papers were entered in the draft gear competition which closed May 15. The majority of them proved to be exceptionally good and the judges have suggested that at least 12 of them are well worth publishing in the Mechanical Edition. The very remarkable thing about the competition is that there is very little duplication in the expression of ideas in these 12 papers. It was not an easy task to decide upon the prize winner, but the honor was finally conferred upon E. W. Newell, a mechanical engineer of Pittsburgh, and a check for \$100 has been forwarded to him. Other contributions which have been accepted for publication are those presented by C. L. Bundy, general foreman of the Delaware, Lackawanna & Western, Kingsland, N. J.; Millard F. Cox; George L. Harvey, mechanical engineer, Chicago; W. H. Hauser, engineer of tests of the Chicago & Eastern Illinois, Chicago; J. W. Hogsett, chief joint inspector, Fort Worth, Tex.; H. C. May, superintendent of motive power, Chicago, Indianapolis & Louisville, Lafayette, Ind.; E. S. Pearce, Chicago; William Schmalzind, foreman of car department, Texas & Pacific, Fort Worth, Tex.; F. H. Sweringen, master car builder, Streets Western Stable-Car Line, Chicago; George Thomson, master car builder, Lake Shore & Michigan Southern, Englewood, Ill. and Myron E. Wells, Ann Arbor, Mich.

### Interchange Inspectors' Convention

Up to the year 1898 there was such a marked variation in the interpretation of the M. C. B. rules of car interchange at the large interchange points throughout the country that it was almost impossible for one large interchange point to pass cars through to another similar point without their being refused. About this time the idea was conceived by H. Boutet, chief interchange inspector at Cincinnati, of getting the different chief interchange inspectors of the country together in an endeavor to come to an understanding on a uniform interpretation of the M. C. B. rules. The matter was taken up with the committee on interchange inspection at Cincinnati and the first meeting was held at Cincinnati in April, 1898. There were ten chief interchange inspectors present. This was the beginning of the Chief Interchange Car Inspectors and Car Foremen's Association of America, which will hold its next annual convention at the Hotel Sinton, Cincinnati, August 25-27. Meetings have been held regularly, ever since the organization was formed, at the large interchange points and it is generally conceded that a great deal of good has been accomplished in supplying correct interpretations for the rules of interchange. This association is deserving of all possible encouragement on the part of the railways, and if the practice were to become general of having car foremen attend the meetings there is no question that a great many of the differences which arise in the interpretation of the M. C. B. rules of interchange could be avoided.

### July Mechanical Conventions

Two important mechanical associations will hold their annual conventions during July. The International Railway General Foremen's Association will hold its annual meeting at the Hotel Sherman, Chicago, July 14-17, while the American Railway Tool Foremen's Association will hold its sixth annual convention there, July 20-22. Both of these associations have accomplished a great deal of good work and deserve every encouragement. The officers and committees of both have worked hard to provide good subjects for discussion at the conventions and every one who is interested should be prepared to take part in the discussions. The word prepared is used here advisedly: the discussion at most of our conventions is too wordy and much of it means almost nothing. If the members will take a short time to think over what they desire to say and make it as concise and to the point as possible, the



discussion and the business of the conventions will not only be greatly expedited, but the printed proceedings will prove much more attractive and useful than they do in most cases at present. The steps taken by the General Foremen's Association this year in furnishing well printed advance copies of the papers to be discussed, with the idea of omitting the reading of the papers before the convention, should prove a step in the right direction, provided the members will take the trouble to go over these advance copies before they undertake to discuss the papers. Much time is wasted at conventions in the reading of papers that the members could read and study over beforehand to much better advantage.

-----

**Competition on Engine House Work** This is a final reminder that the competition on engine house work, which was announced in the May issue, will close on July 15. A prize of \$50 is offered for the best article on this subject received before that date. The judges will base their decision on the practical utility of the suggestions made or the practices which are described, and space rates will be paid for articles which are accepted for publication but do not win the prize. No restriction is placed on the subject chosen except that it must be along the lines of the handling of running repairs to locomotives in roundhouses. A number of articles have already been received and others who contemplate taking part in the contest should not delay in sending in their contributions.

-----

**More Information Wanted About Draft Gear** Thirteen of the 16 papers presented in the draft gear competition favored the friction draft gear. Two of the papers which presented the best arguments for the spring gear have been accepted for publication, but space limitations would not permit their use this month. The combination of the four papers which appear in this issue forms a fairly complete presentation of the draft gear subject. The other eight papers, however, are almost equally as interesting and will be divided into two sets, one to be used in the August number and the other to be published in the September issue. It is quite probable that as you read the four papers in this issue you may find that you have at hand data, or have had certain experiences which will be helpful to our readers in making a more forceful presentation of certain features of the draft gear problem. If you have such data, or if you believe any of the suggestions which are made are incorrect, please write immediately to the editor, giving him such facts as you may consider will be of value in helping to solve this most important problem. If our readers will do this it will help to clear up many of the misunderstandings which have prevented a more intelligent action on the part of many railroad officers in dealing with the draft gear question. Such communications as are accepted for publication will be paid for at our regular space rates. Please consider this as a personal invitation to participate in the discussion on this subject.

-----

**The Draft Gear Problem** The 12 papers presented in the draft gear competition, which have been selected for publication, cover the subject very thoroughly, with the one exception that too few examples were given of exact service data showing the comparative value of the different types of gears. On the other hand, most of the men who took part in the competition were well fitted, either from long study of the question or from very extensive experience in the handling of car repairs, to discuss the subject to the very best advantage. The 12 papers have been divided into three sets, to be run in successive issues of the Mechanical Edition, and taken as a complete whole will form one of the most impor-

tant contributions on the draft gear subject, and that of the cost of freight car maintenance, which has ever been placed on record. So important is this subject that this will only form the basis of a campaign which we propose to develop in the attempt to bring out definite facts to demonstrate clearly just what types of draft gear give the best results in service.

The four papers presented in this issue each approach the subject from an entirely different viewpoint, and taken together really form one very complete unit in the draft gear discussion. For instance, the prize winner, W. E. Newell, who is a mechanical engineer in Pittsburgh, has apparently studied the subject almost entirely from the standpoint of a designer and engineer. In a simple but attractive form he has summed up the various tests to which he has had access, placing at the head of these certain convincing data based on service conditions. Mr. Thomson the author of the second paper and the master car builder of a most important division on the Lake Shore, has had 24 years of practical experience in car department work. He has made splendid use of this experience and his observations are worthy of the most careful consideration. The third paper, by Mr. Hauser, is more or less of a side light on the draft gear problem and presents authoritative figures showing the rapid increase in the cost of freight car repairs during recent years, which is out of all proportion to the increased capacity or service of these cars. This cannot continue and something must be done immediately to improve conditions in this respect. There seems to be little question but that a proper selection of draft gear will do much to hold these ever increasing costs down. Mr. Wells' paper takes an almost diametrically opposite position. While he apparently believes in the high capacity modern draft gear, he is very strongly of the opinion that the greater part of the damage is due to a careless handling of the cars in switching. Mr. Wells is a very keen observer and his conclusions are based upon an extensive experience in firing and running locomotives in both yard and road service, and in a very considerable amount of experience in caring for and maintaining locomotives on the Chicago, Burlington and Quincy; the Wabash, and the Wheeling & Lake Erie. His comments cannot be passed over lightly.

Mechanical department officers do not want to evade any responsibility. It is up to them to care for and maintain the equipment in first class condition so that it can properly perform its functions. Nevertheless there is no question but that the equipment is very severely abused by the operating department and that on some roads it will be absolutely necessary to take radical steps to overcome this abuse. In fact, it is really surprising that it has been allowed to continue as long as it has. No one who is familiar with switching yard practice, particularly at night, can forget the sounds which undoubtedly remind veterans of a heavy cannonading on a battlefield. In this connection it is interesting to consider the following quotation, which is taken from the first prize article in the Railway Age Gazette competition on the Operation of Large Classification Yards. A. M. Umshler, general yardmaster of the Illinois Central at Centralia, Ill., in the prize winning article, said: "He [the yardmaster] should impress upon his subordinate employees the necessity of doing their work promptly and properly and should not allow them to lose sight of the absolute necessity of handling all equipment carefully. It is an established fact that considerable damage to equipment occurs in a yard, not always of such consequence that a car must be sent to a repair track before it is in condition to go forward, but the draft gear may be so weakened in handling that it cannot pull its part of the weight and sooner or later the weakened part will give way. This is one of the paramount questions of successful yard operation, as a great deal of delay to cars is

directly due to the manner in which they are handled and as a result considerable time is lost by each car in the course of repairs."

The important arguments against the spring draft gear, as developed in the competition, are its lack of capacity and the damage done by the recoil. The strongest criticism of the friction draft gear is its stiffness, which it is claimed does not allow it to come into action sufficiently under ordinary pulling and buffing shocks. We may theorize on the relative merits of the two gears as much as we please and we may criticize the various laboratory tests which have been made as unfair and too much at variance with service conditions, but after all what really counts, and will really settle this entire question, is the actual service results. It is, therefore, not surprising that several of the contributors insist that money would be well spent in developing certain accurate and complete records to show the cost of maintaining the different types of draft gear; and more than that, that it should go beyond this and take into consideration the damage which is done to other parts of the car and even to the lading in the car.

A general manager paused in passing through a terminal freight yard one day and with a thoughtful expression sized up an exceptionally strong bumping post which had been torn and distorted since his last visit. He said: "If there was only some way of determining the exact damage which was done to the equipment when this post was distorted, and if we could present to the crew which did the damage a statement of this expense, before they went off duty or the next day, it might cause them to use more horse sense in handling the cars in the yard." Damaged cars are probably as much an indication of man failure as they are of draft gear failure, and at the same time that the mechanical department officers are analyzing the costs to determine which is the most satisfactory gear, the operating department ought to do its part by seeing that its employees are educated and trained to be more thoughtful in the handling of the cars. It would prove a paying proposition.

Much time and thought and a great deal of expense have been expended by the coupler committee of the Master Car Builders' Association in developing a stronger and standard coupler. The committee which has this work in charge is to be congratulated on the splendid work which it has done. It is not in any spirit of criticism, therefore, that the suggestion is made that a more efficient cushion behind the coupler may do much to finally influence the association to adopt a lighter coupler as standard than many people at this time believe to be necessary under present conditions. Meanwhile every road should do its part in testing the couplers which have been recommended and in collecting and compiling data to show the effect of the different draft gears, or cushions, used behind the various types of couplers either now in use or about to be experimented with.

Last month we suggested in an editorial note that more attention should be given to the maintenance of the draft gear. Surely it is not the least important part of the car, and yet its inspection and its maintenance is very largely overlooked as compared with such parts as wheels, axles, couplers, air brakes, etc. If good performance is to be expected of a draft gear it must be inspected and thoroughly overhauled at regular intervals. One car builder has suggested that this overhauling should be done every four or five years and that the car should be stenciled with the date on which this took place. The proposed interval would probably vary more or less, depending on the make of draft gear used. Gears with several parts subject to more or less wear would have to be looked after more frequently than those with fewer parts and with larger wearing surfaces. So far as we know no practice of this sort now exists on any road. If it does we should like very much to have definite information of it in order

that our many friends who are interested in the draft gear question may have the advantage of the methods which have been followed and the experience which has thus far been gained.

#### NEW BOOKS

*Business Administration.* By Edward D. Jones. Bound in cloth. 275 pages. 5 in. by 7½ in. Published by the Engineering Magazine Company, New York.

Believing that the administration of manufacturing and operating companies under modern conditions is developing into a new profession, the author of this book has sought its scientific principles by a study of the older professions with which it is closely allied. His argument is, briefly: that success in dealing with men and affairs depends upon certain basic propositions and laws which can be discovered by studying the work of successful administrators; that the rules and methods followed by masters of business and finance are usually deliberately hidden and there are no records throwing clear full light on their lives and acts; that leaders in statecraft, war and science, on the contrary, are figures of world interest whose careers and practice are illuminated fully and searchingly by public and private records, correspondence, personal reminiscences and even petty gossip. From such data the author has analyzed definite primary principles of administration. In history and the biography of military conquerors, diplomats and scientists, he finds the elementary rules of success.

*Tests of Bond Between Concrete and Steel.* By Duff A. Abrams. 238 pages, 6 in. by 9 in.; illustrated; bound in paper. Published by the University of Illinois. Copies free on application to C. R. Richards, acting director of the engineering experiment station, Urbana, Ill.

In designing structures of reinforced concrete it is important to know the amount of stress which may be developed between the surface of the reinforcing bars and the surrounding concrete before failure is produced by the slipping of the bars. This stress is what is commonly termed "bond." The above-mentioned bulletin gives the results obtained by pulling out bars embedded in blocks of concrete and also the results of tests made to study the bond stresses developed in large reinforced concrete beams. Nearly 2,000 tests are reported and a wide range of conditions is represented. This is one of the most exhaustive studies of the amount and distribution of the bond stress between concrete and steel which have appeared.

*The Tractive Resistance of a 28 Ton Car.* By Harold H. Dunn, assistant in railway engineering, University of Illinois experiment station. 53 pages, 6 in. x 9 in.; illustrated; bound in paper. Published by the University of Illinois. Copies free on application to C. R. Richards, acting director of the engineering experiment station, University of Illinois, Urbana, Ill.

This is Bulletin No. 74 and records the results of tests made with a 28-ton electric car of the double end type for the purpose of determining the resistance offered to its motion when running on straight level track in still air at uniform speed, and to ascertain the relation existing between that resistance and the speed of the car. The tests were made on sections of straight track representative of good electric railway construction during generally fair weather when the average temperature was not below 25 deg. F., and when the wind velocity did not exceed 26 miles per hour. The plan of the tests, which involved running the car backward and forward over a selected section of track, made it possible to eliminate wind resistance. The results are finally expressed in the form of a curve whose co-ordinates are car resistance and speed. This curve shows that at 5 miles per hour the car resistance was 5.25 lb. per ton, that at 25 miles per hour it was 13.03 lb. per ton, and that at 45 miles per hour it was 26.12 lb. per ton. The average results from the individual tests did not vary more than 9 per cent from this final curve.



# COMMUNICATIONS

## ENCOURAGE EMPLOYEES TO STUDY

LOS ANGELES, Cal., February 21, 1914.

TO THE EDITOR:

Referring to the article in the February number of your magazine on the "Development of Young Men in Railroad Work," I suggest that the railroads establish libraries at their general shops and large terminals, these to be in charge of a librarian. All the engineering magazines, as well as other magazines pertaining to the different phases of railroad work should be placed in them. At the end of the year the principal ones should be bound and indexed, the same as in any other library. Important books on railroad work should be included in the list.

Then all employees should be given free access to the library; and all from the sweeper up should be urged to make use of this literature. All apprentices should be required to read a certain amount weekly along the line of their work. This would help develop the young men, make better men out of the older ones, and in general would raise the standard of all connected with the railroads.

EDWARD L. DUDLEY.

## BORING ECCENTRIC STRAPS

RICHMOND, Va., May 25, 1914.

TO THE EDITOR:

We recently made a good record boring eight 17½ in. bronze eccentric straps on a New Era type, 42 in. Bullard maximill, at our Seventeenth street shops, Richmond, Va. The actual time consumed in each operation was as follows:

	Chucking time, minutes	Roughing time, minutes	Finish time, minutes	Taking out of chuck, minutes	Time, floor to floor, minutes
1.....	1½	3½	2	1	8
2.....	1	4	1½	1	7½
3.....	1½	3	2	1	7½
4.....	1	3	1	1	6
5.....	1½	3½	1½	1½	8
6.....	1	3½	1½	1	7
7.....	1½	3½	1½	1½	8
8.....	1	4	1	1	7

Total time ..... 59 minutes  
Average time per strap, 7 minutes, 22½ seconds.

The straps, when placed at the machine for boring, were otherwise complete, including facing and drilling the T foot to standard.

The method of doing this work is as follows: The chucking is done by first fastening the T foot of the strap with turned bolts to the fixed lug. This lug is securely bolted to the table



Fig. 1

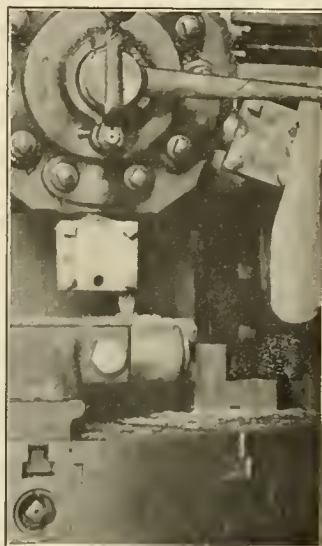

Fig. 2

of the machine, as shown in Fig. 1. The other jaws are then tightened. No time is lost in setting, as the special lug brings the strap to the proper position when the bolts are tightened. The side is then faced (one cut), as shown in Fig. 2; the rough boring is next done, as shown in Fig. 3, and the finish boring



Fig. 3

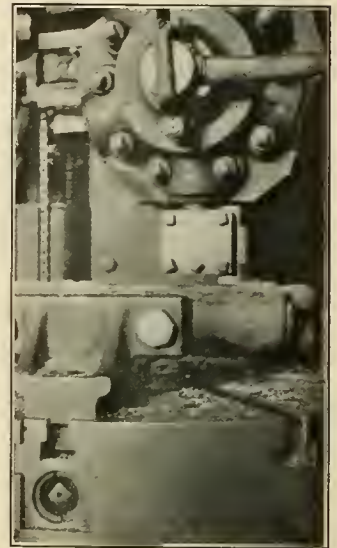

Fig. 4

is then done with a master tool of exact contour, as shown in Fig. 4, making a perfectly smooth finish.

By doing the work in this manner, we have been able to effect a saving in time of 75 per cent over the old methods.

M. FLANAGAN,  
Master Mechanic, Chesapeake & Ohio.

USE OF WOOD IN NEW YORK STATE.—According to a statement from the New York State College of Forestry at Syracuse University, New York is the greatest wood consuming state in the Union. It uses over 2,000,000,000 board feet every year in its wood-using industries and for general construction purposes. New York uses about 150 different kinds of foreign and domestic woods in the varied industries.

HOURS OF SERVICE ACT.—During the fiscal year ending June 30, 1913, 306 cases, involving an aggregate of 3,499 violations of the hours of service act, were transmitted to the several United States attorneys for prosecution. During the same period the carriers confessed judgment as to 1,750 counts. Of the 455 counts which went to trial, 186 resulted in favor of and 269 adversely to the Government. Of the latter, 214 counts have been appealed by the Government, and 63 of the 186 counts originally decided in favor of the Government have been appealed by defendants. Penalties aggregating \$100,861.14 were collected, and additional penalties to the amount of \$32,350, in addition to costs previously assessed by the courts, were on July 1, 1913, pending payment by the carriers.

RAILROAD BETWEEN PORTLAND AND QUEBEC.—A public meeting was held in Quebec on Monday, 20th inst., to consider the proper preliminary steps to be taken in favor of this enterprise. J. W. Woolsey was in the chair, K. Fisher, secretary. Mr. A. Smith, one of the commissioners appointed by the state of Maine, was introduced to the meeting and explained the views and wishes of Maine on the subject, all of which tended to increase the facilities of intercourse between the United States and Canada. He was received with cheering, and resolutions were subsequently passed, asking the concurrence of the Governor of Canada in the efforts making by Maine, and in those which the citizens of Quebec stand ready to make.—From American Railroad Journal, August 1, 1935.

# PENNSYLVANIA MIKADO TYPE LOCOMOTIVE

Advanced Design with Many Parts Interchangeable  
with the Latest Development of the Pacific Type

[Editor's Note.—A brief description of the Pennsylvania Mikado and Pacific type locomotives, classes L1s and K4s, was published in the Daily Railway Age Gazette for June 15, 1914, page 1411. Some of the data given in this article were approximations which were all that could be obtained at that time, and will be found to differ slightly from the present figures, which are correct.]

During the past few years there has arisen a need for a larger freight locomotive for use on the main line of the Pennsylvania Railroad between Altoona and Pittsburgh. The employment of

motives has been carried out as far as possible, as well as the use of many of the parts which are embodied in the class E6s Atlantic type locomotive.\*

## BOILER

The boilers of the Pacific and Mikado locomotives are interchangeable, and an interesting feature is the flanging of the throat sheet in an integral piece with the lower half of the rear barrel sheet. This has permitted of lowering the boiler  $1\frac{7}{8}$  in., and at the same time allows sufficient clearance for the

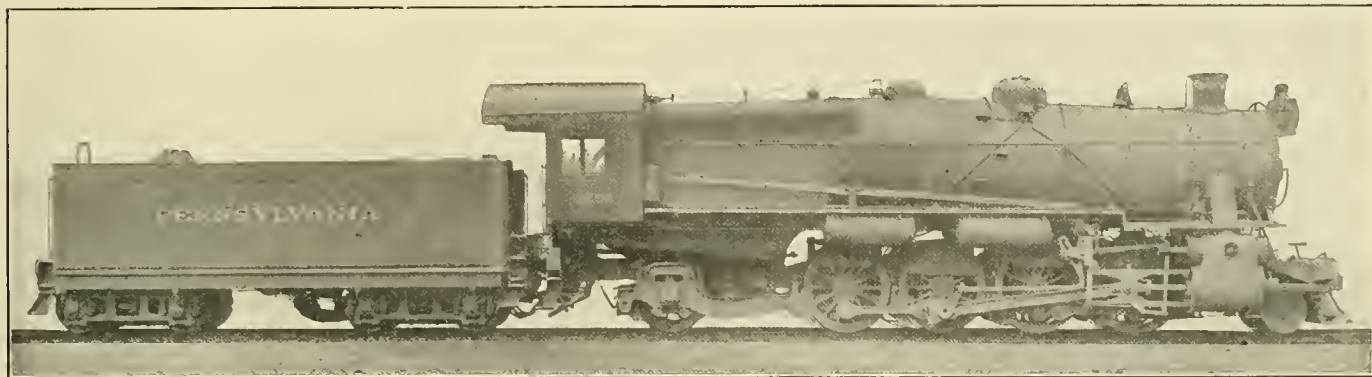

Pennsylvania Mikado Type Locomotive

such an engine is desirable in order to reduce double heading to a minimum, and to avoid the necessity of breaking up trains which arrive at Altoona and Pittsburgh, and sending them forward over the Pittsburgh division in sections. At the same time it was thought desirable to experiment with a heavy Pacific type locomotive for passenger service on this division. There has accordingly been designed and built a Mikado type locomotive which bears the railway company's classification L1s and a Pacific type designated as class K4s.

It was necessary to keep the locomotives within certain limits,

rear driving wheels. The boiler is of the Belpaire type, and has 237  $2\frac{1}{4}$  in. tubes, and 40  $5\frac{1}{2}$  in. superheater flues, all of which are 19 ft. long. The firebox is 126 in. long by 80 in. wide, and is fitted with a combustion chamber; the grate area is 70 sq. ft. The inside diameter of the boiler at the forward end is 78  $\frac{1}{2}$  in., with an inside diameter of 87 in. at the dome course. The dome is flanged in one piece. The design of smoke stack employed is the result of much study, and an inside extension is used extending below the center line of the smoke box, as will be seen from the engraving.

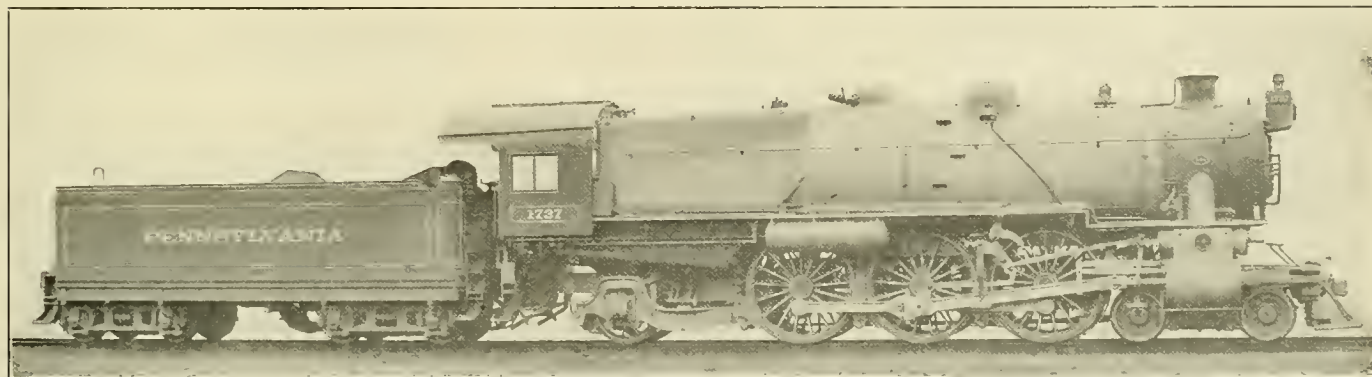

Latest Development of Pacific Type Locomotive on the Pennsylvania

because of restrictions in road clearance, and make the revolving and reciprocating parts as light as possible consistent with the necessary strength; the weight per pair of driving wheels is limited to 65,000 lb., with a 5 per cent margin for scale variations, and there is also a limitation for dynamic augment due to counterbalance for reciprocating weights, of 30 per cent of the weight on drivers at 70 miles an hour for passenger locomotives and at 294 revolutions per minute for freight locomotives. Interchangeability of parts between the two loco-

## FRAMES AND RUNNING GEAR

The frames are of cast steel, 6 in. wide and reinforced to 8 in. over the driving boxes. Heat treated steel has been used wherever possible following the same lines in this respect as in the E6s Atlantic type locomotive previously referred to, among the parts in which this material has been employed being the driving axles, crank pins and piston rods, as well as the main

\*For description of the Pennsylvania class E6s Atlantic type locomotive see Railway Age Gazette, Mechanical Edition, February, 1914, page 63.





One of the illustrations shows the arrangement of the driver brake cylinders. It was found necessary to use two 16 in. cyl-

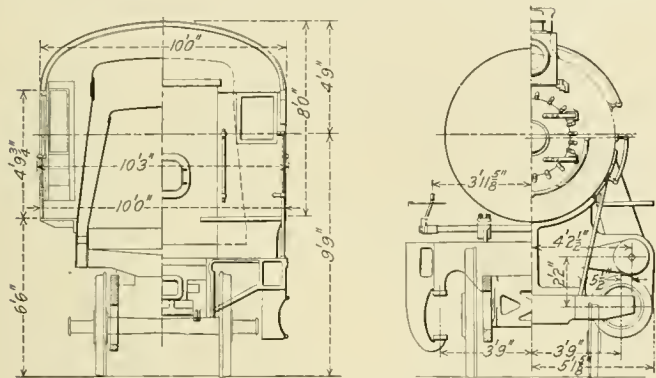

End Elevations and Cross Sections of the Mikado Type

inders, and because of space limitations the arrangement shown was employed.

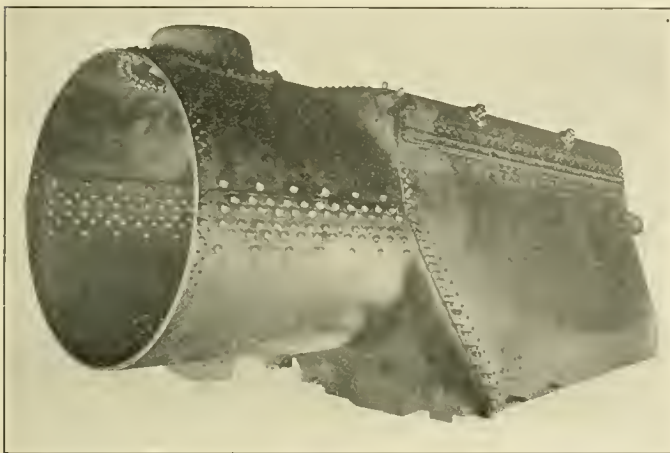

Outer Shell of the Firebox and Dome Course of the Boiler

OTHER DETAILS

The locomotives are equipped with Schmidt superheaters and Security brick arches. Screw reverse gear is used, and because of its not being necessary to provide space to move the reverse

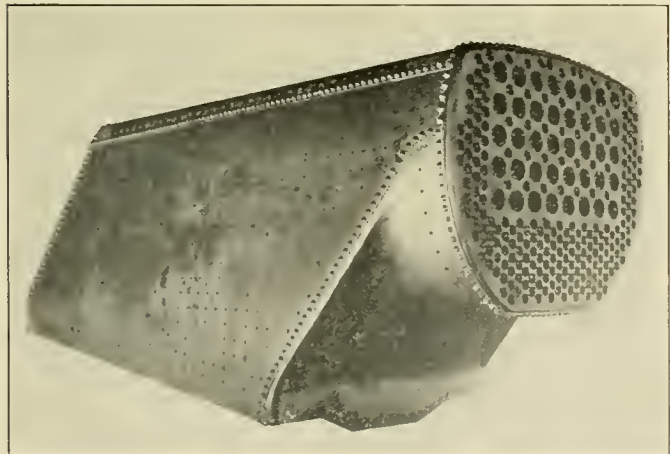

The Assembled Firebox for the Pennsylvania Locomotives

lever the cab has been considerably shortened. It is also believed that the shorter cab will give the engine crews a better opportunity to observe signals. The tender truck is of the same design as that used on the E6s Atlantic type locomotive. The

tank is of the water bottom type with 36 in. wheels and 5 1/2 in. by 10 in. journals. The water capacity is 7,000 gal., and the coal capacity 12 1/2 tons.

These locomotives, as well as the latest design of Atlantic type, were designed in the office of the mechanical engineer of the Pennsylvania Railroad at Altoona, and built in the Juniata shops. The E6s class Atlantic type locomotives are now haul-

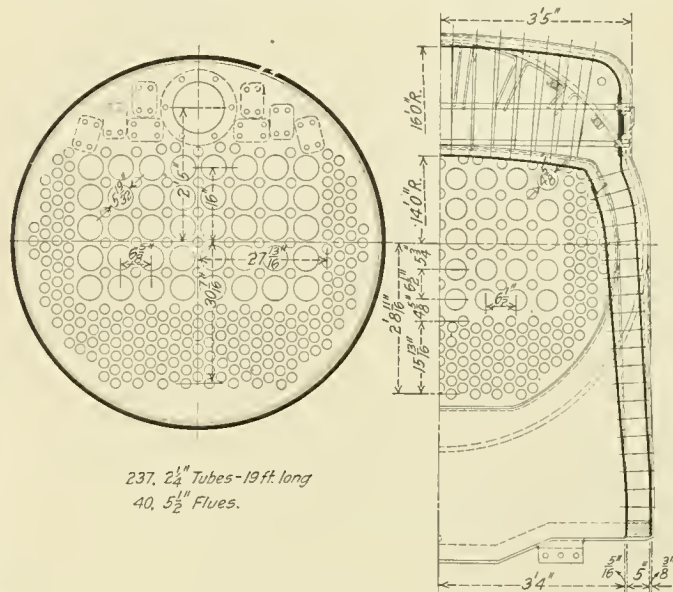

237, 2 1/2" Tubes-19 ft. long  
40, 5 1/2" Flues.

Cross Sections Through the Boiler

ing very heavy trains on most exacting schedules, and the service results are amply justifying the design. It is expected that equally satisfactory results will be obtained from the new Mikado and Pacific types.

Tabular comparisons are given below between the Mikado type and the Pennsylvania Consolidation type of the H9s class,

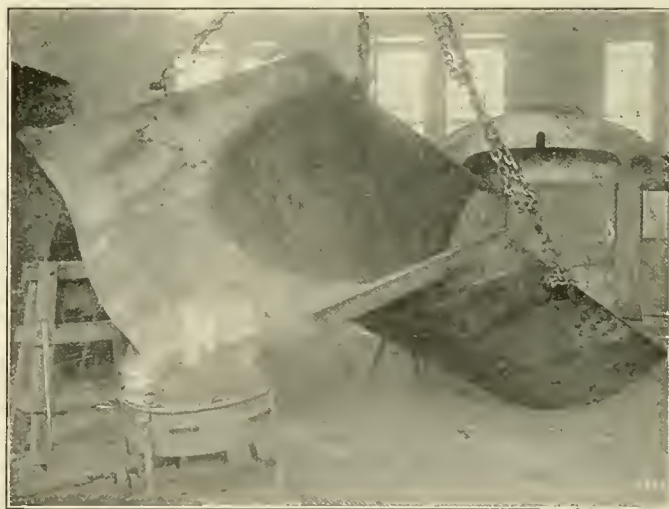

The Lower Half of the Dome Course is Flanged in One Piece with the Throat Sheet

as well as between the new Pacific type and the E6s Atlantic type:

CONSOLIDATION AND MIKADO TYPES  
General Data

Railroad classification	H9s Consolidation	L1s Mikado
Type	Consolidation	Mikado
Gage	4 ft. 9 in.	4 ft. 9 in.
Service	Freight	Freight
Fuel	Bit. coal	Bit. coal
Traction effort	46,290 lb.	57,850 lb.
Weight in working order	250,000 lb.	315,000 lb.
Weight on drivers	220,000 lb.	238,000 lb.





## MODERN LOCOMOTIVE COALING STATION

The committee on Modern Locomotive Coaling Station, of the International Railway Fuel Association, in a report presented at the convention in May, decided that, as practically each railroad will have certain restrictive conditions that might prevent the adoption of any recommendations that might be made, it would serve the best interests of the association by submitting only such suggestions as might embody the best recommended practice for securing the highest true economies.

*Location.*—We would emphasize our former conclusions, revised as follows:

The committee recommends a very careful study of the character and source of the supply of fuel, and its possible future permanency, before locating any so-called permanent structures.

Where it can be accomplished without too great an expense, modern coaling stations should not be located at the large centers of population.

It might prove economical to locate coaling stations away from terminals a distance equal to that which can be covered by one locomotive tank supply.

Grade conditions, density and direction of traffic, loaded and empty car haul, junction point, location of supply, are all factors for careful consideration.

*Design.*—The committee feels that three types should cover the usual requirements and has confined its consideration to these three types.

*Type One.*—Gravity chutes, drop-bottom cars, handled up incline by locomotives or by oil, electric or steam power hoists.

*Type Two.*—Balanced buckets, using oil, steam or electric power; drop-bottom cars, coal dumped into pit and elevated by one to four balanced buckets, holding one to three tons each.

*Type Three.*—Bucket conveyor, using oil, steam or electric power; drop-bottom cars, coal dumped into pit and hoisted to main bins by small buckets on chain or link belt.

There are certain general features that should be embodied in the design of any of these three types, and the committee would make the following recommendations:

Breaker bars are deemed necessary and should be used until such times as the railroads may be able to arrange for the proper preparation of the size of the coal at the mines.

The track openings should always be so generously designed and provided as to fit the length and the width of the openings of the cars, and to prevent any clogging and to provide free and easy dumping.

The storage bins should be designed to permit of frequent cleaning and inspection. They should be divided by at least one partition and each subdivision should be furnished with several openings. All receptacles for coal should be designed to avoid the probability of any clogging in the corners. Warped surfaces ending at the openings will naturally destroy a certain amount of storage capacity, but should be given careful consideration. Whenever practicable, the point of delivery of the fuel to the bin should be directly above the opening of the discharge of the fuel to the tank.

If coal is easily fractured or powdered and whenever the fall is of considerable height, deflectors may be used to advantage, but they may be the cause of the fuel clogging.

The committee again calls attention to the necessity for providing warped surfaces or valleys at the angles of all storage bins and pockets, and this recommendation affects its suggestions in this connection. Naturally no fixed angle can be recommended to cover all classes of fuel, but it is believed that a slope of from 35 to 45 deg. will best serve in designing bins, pockets, hoppers, chutes and aprons.

All gates, doors, etc., should be designed to be freely opened and to the full size of the opening, to provide for the easy releasing and movement of the fuel.

The capacity of any coaling station is naturally dependent on the proper preparation of the fuel, the regularity of its supply and the frequent switching service of the road cars. Where these are normal and dependable, the committee recommends the following, with the understanding that it is not economical or desirable to hoist during the night hours:

TYPE ONE	
For 24 hours' service for 10 locomotives.....	100 tons
For 24 hours' service for 25 locomotives.....	200 tons
For 24 hours' service for 50 locomotives.....	400 tons
For 24 hours' service for 100 locomotives.....	600 tons
TYPE TWO	
For 24 hours' service for 10 locomotives.....	100 tons
For 24 hours' service for 25 locomotives.....	100 tons
For 24 hours' service for 50 locomotives.....	200 tons
For 24 hours' service for 100 locomotives.....	400 tons
TYPE THREE	
For 24 hours' service for 10 locomotives.....	100 tons
For 24 hours' service for 25 locomotives.....	100 tons
For 24 hours' service for 50 locomotives.....	200 tons
For 24 hours' service for 100 locomotives.....	400 tons

The foregoing capacities are recommended, having in mind the necessity for filling the bins several times during the day, and stations should be designed to provide for hoisting capacities (minimum) as follows:

For 50-ton bin capacity.....	20 tons per hour
For 100-ton bin capacity.....	40 tons per hour
For 200-ton bin capacity.....	60 tons per hour
For 400-ton bin capacity.....	100 tons per hour

In regard to the construction the committee recommends reinforced concrete and steel construction as being first choice, but in any event steel should be used for all supports under bins and hoppers, and for the general structure. Whenever any of the storage parts come in contact with the fuel, they should be protected by reinforced concrete slabs.

The committee recommends that more care be used in the selecting of the men for operating the modern locomotive coaling station, and it believes that it would be economy to select men with sufficient mechanical experience to intelligently inspect and operate the plant, and to make running repairs thereto. A more careful inspection and operation would reduce maintenance costs and many running repairs would be made that now are expensive items, due to careless or ignorant operation.

*Costs.*—We have endeavored to secure actual figures to show costs for operating the different types of stations for the fiscal year ending June 30, 1913, but so few replies have been returned in answer to our inquiries, that an analysis of the subject is hardly possible. They indicate that there are as many methods used to secure figures as there are systems submitting them.

The report is signed by Hiram J. Slifer, chairman, E. A. Averill, E. E. Barrett, W. E. Dunham, G. W. Freeland, W. T. Krausch and R. A. Ogle.

### DISCUSSION

If scales are to be used they should be thoroughly inspected often by competent scale inspectors, and if handled properly and carefully there is no question but that the shortages could be more accurately determined, but whether the information thus gained would warrant the expense of the scale was a matter which many were not quite sure of.

The angularity of the chute received considerable consideration, several members favoring a slope of over 50 deg. for run of mine coal as then there would be a more equal distribution of the lump and slack and it would be easier to clean out the chute. Mr. Crawford stated that no matter what slope the chutes have, they should all be cleaned frequently, the time between cleanings depending upon the grade of coal handled. On the Burlington some of the chutes are cleaned as often as every two weeks, twin bins being provided so that while one is being cleaned the other may be used for loading the locomotives. There should be no projections that will in any way interfere with drawing the coal direct from the bin, or allow the fine stuff to collect. Deflectors should be used where necessary to get a good, even distribution.



TYPICAL EXAMPLES OF RECENT LOCOMOTIVES

ARRANGED IN ORDER OF TOTAL WEIGHT

MIKADO TYPE

Table with multiple columns: Type, Name of road, Road number or class, Builder, When built, Tractive effort, Weight, Weight on drivers, Weight on trucks, Weight on trailer, Wheel base, Wheel base, engine and tender, Diameter of drivers, Cylinders, Cylinders, stroke, Valve gear, Steam pressure, Boiler, Tubes, Flues, Length of tubes and flues, Heating surface, Heating surface, firebox, Heating surface, superheater, Grate area, Firebox, length, Firebox, width, Kind of fuel, Tender, coal capacity, Weight on drivers, Evap. heat, Firebox heat, Firebox heat, Total heat, Tractive effort, Total weight, Volume equivalent simple cylinders, Total heat, Grate area, Reference to photograph, drawings or description. Each row contains data for a specific locomotive model.

\*Locomotive Dictionary.













The chisel shown in Fig. 2 is made of  $\frac{3}{4}$  in. square steel. The chisel previously furnished was made of hexagon steel the same as that furnished the shop men, and a large number of the chisels placed on locomotives eventually found their way to the lockers of the shop men. The square chisel, if used by the shop men will have a tendency to cut their hands, and will therefore eliminate the taking of chisels from locomotives.

The coal pick shown in Fig. 3, the head of which is made in a forging machine and to which a  $\frac{3}{4}$  in. iron pipe handle is welded, will overcome the trouble with broken handles. The fire tools shown in Fig. 4 have the ends made in a forging machine and the handles are welded to them. This process of manufacture reduces the original cost and increases the life of the tool. The engineer's oil can shown in Fig. 5 was designed after investigation showed that the spout formerly used was too long and the length of the spout shown was decided upon after examination of a number of oilers on which the spouts had failed. The capacity of the can is made so that it will hold the largest supply of engine oil furnished on the system; the necessity for carrying an addi-

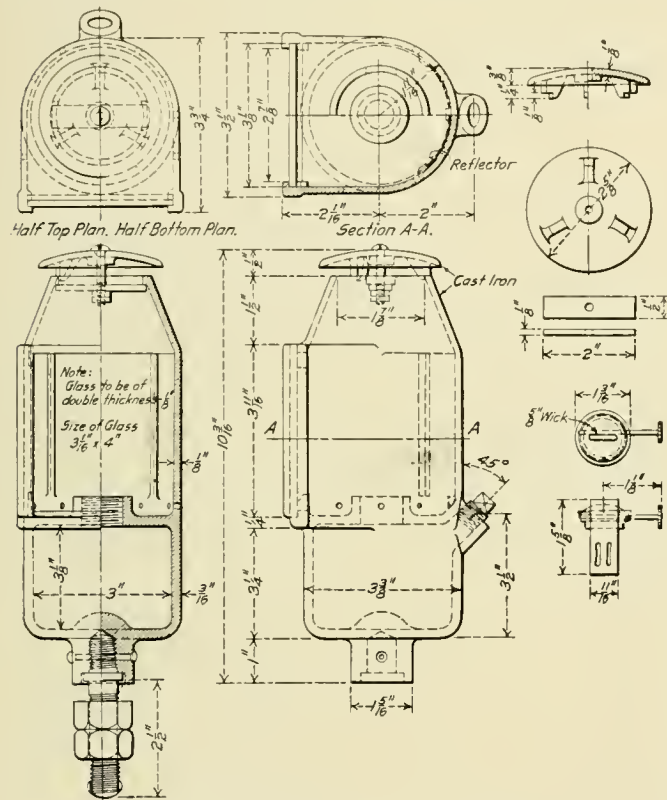

Fig. 9—Car Lamp for the Water Gage

tional supply can for engine oil is thus avoided. The can is very substantially made and has a thumb trigger for operating the valve, which is located on the right side of the handle rather than in the center, as it develops that by placing it in this position the engineers are better able to operate the valve and the loss of oil is consequently reduced to a minimum.

The extra valve oil supply can shown in Fig. 6, which is to be used only when it is necessary to carry a double supply on the engine, is made of such capacity that it will hold one supply only, the second supply being placed in the lubricator. The spout on this can is so designed that it is possible to fill the lubricator without any loss of oil, this shape being decided upon after considerable experimenting. The can is of such shape that it does not take up much room, which is an important consideration in storing cans when not in use. The cab lamp for pressure gages shown in Fig. 7 is made of cast iron and takes the place of the sheet iron lamp formerly used. This design, on account of its increased strength, has reduced very considerably the number of cab lamps furnished for this purpose. Where it is necessary to

use a cab lamp for the water gage, the cast iron design shown in Fig. 9 is used. This lamp is in one piece, the fount being a part of the body. White and red lanterns should be of such a design that the danger of breaking the globes is reduced to a minimum and of such a shape that they will not be convenient for train men's use.

The receptacle for fuses, flags and torpedoes should be so designed that there is no possibility of their becoming wet, and at the same time they should be within convenient reach. A very good receptacle for these supplies is illustrated in the cab seat box shown in Fig. 8. This has a compartment under the seat for this purpose. The tender tank tool boxes should be conveniently fitted with trays or shelves for the storing of tools. When the locomotive is at a terminal or is placed in the shop for repairs, all tools and supplies should be removed and placed in the store or supply room provided for this purpose. Hostlers should each be furnished with a shovel, which they can retain for shop purposes.

When a system such as that described has been installed and is in good working order, it will do away with the practice of running the locomotive tool and supply list on the plan of "first in first out," that is, removing the tools of a locomotive just coming in to one just going out, which requires a considerable amount of time on the part of the tool supply men, and very often results in an unnecessary terminal delay. The time thus saved by the supply men can be used to good advantage in making minor repairs to such tools as need them.

## ECONOMIES IN ROUNDHOUSE AND TERMINAL FUEL CONSUMPTION

The following is from a paper by F. W. Foltz, fuel supervisor, Missouri Pacific, read at the convention of the International Railway Fuel Association, May 18-22, 1914:

Investigation develops that from 15 to 25 per cent of the total coal used by locomotives is consumed in roundhouses and at terminals while they are not actually performing service. Engine crews should be taught to bring their engines to the cinder pit, at the completion of each trip, with a thin fire, the boiler full of water and nearly full steam pressure. As far as practical the fire should be allowed to burn lowest at the back end of the firebox, as the fire cleaner drops the back dump grate first. The fireman, before leaving his engine, should throw two or three shovelfuls of coal into the forward end of the firebox, to act as a protection to the flues.

Locomotives should receive immediate attention on arrival at the terminals. In cleaning the fire any unburned coal should be pushed ahead, the back section of the grates shaken, then the dump grate dropped and any clinkers pulled back and forced through the dump. After this operation, the grates should be leveled and the dump grate closed. If the engine is to lie over several hours, the fire should be pushed ahead, leaving the dump and one or two grates bare, then covered over as the condition of the fire warrants, but in all cases sufficiently to prevent the pops opening. When the engine is ordered, the fire should not be broken up until shortly before leaving time, unless it is necessary on account of a poor fire. The excessive use of the blower should be guarded against at all times and especially when cleaning the fire.

Too great care cannot be given at terminals to the proper cleaning of flue sheets and flues. This applies more especially to our superheated engines. Roundhouse foremen should give this work particular attention, instruct the men and provide proper tools for the work, and I would suggest that a cent or two more an hour be paid for this work as an incentive for better service. The proper washing and cleaning of boilers at terminals is one of our greatest factors in fuel economy.

Material saving can be made in firing up locomotives at



terminals. I have found at many terminals where they were bedding down grates, using 90 scoops of coal (where shavings were used to start the fire), but after carefully instructing the fire-builder and following it up to see that our instructions were carried out, we were able to get the same results from 40 to 50 scoops of coal. Where shavings are used for starting fires in engines in roundhouses, ash pans should be left open and coal that has fallen through the grates can be picked up from the pit in a wheelbarrow and taken to the stationary plant for fuel. In preparing the fire for service the blower should be used gently so that the fire will burn slowly and the rise of steam pressure will not be too rapid. The sudden expansion of sheets and tubes may result in harm.

In order that the amount of time locomotives are kept under steam, when not performing service, may be reduced to the minimum, a daily report from each terminal will be found of great value. It is also desirable to charge each terminal with the amount of coal consumed by locomotives from the time they are turned over to the hostlers until they are again placed in charge of the road crews.

The coal consumed by stationary boilers is also a feature that has received very little attention on most roads. The inexperienced, cheap laborer—usually employed to heave the coal into the firebox of the stationary boiler is one of the most expensive small units in a railroad organization.

DISCUSSION

Many members laid particular stress on the opportunities for wasting fuel at terminals, and have shown by tests that from 20 to 35 per cent of all the fuel used on locomotives is used at terminals. On investigation some have found that the absolute waste in fuel at terminals is as high as 50 per cent, and that on examination of the ash pits as high as 35 to 50 per cent fixed carbon in the ash has been found. Considerable was said concerning economy at stationary plants. It was believed that if more intelligent firemen were used in this work considerable saving could be made.

Robert Collett, formerly with the Frisco, showed how a good deal of the fuel used at terminals was saved by doubling the length of trips of the locomotives. By careful instructions to the firemen they can so handle their fires that it will not be necessary to perform the cleaning usually made every hundred miles or so. The Frisco now successfully operates one locomotive over a division of 240 miles. Mr. Foltz stated that on four heavy runs between Kansas City and St. Louis that road had saved \$1,000 per month by running their engines through.

The Chesapeake & Ohio are using shavings without oil for starting fires, and find that it provides a much slower burning fire, which gives the coal a much better chance of igniting. It was generally conceded that this practice was good where the shavings were such that they could be used in this way. For mixed shavings containing a lot of sawdust it is necessary to use some fuel oil. One member expressed the opinion that it was much better to use 1,000 or 1,200 lb. of coal in firing up instead of a smaller amount, for otherwise there will be considerable shaking of grates during the time the engine is standing and considerable coal will be fired that would not ordinarily have to be. Special attention was called to the necessity of leaving ash pans open when fires were being built, so that the coal falling through the grate will fall into the pit and not clinker up the ash pan opening. Mr. Bentley, of the Northwestern, believed there were great opportunities of conserving the heat of locomotives by covering the stack while in the roundhouse.

SERVIA AND THE ORIENTAL RAILWAY.—The Servian government has resolved to build a line parallel to the Oriental Railway in case it cannot come to an understanding with Austria-Hungary with reference to the latter.

ELLIPTIC SPRING TABLES

BY ANTHONY SCHMIDT

Leading Locomotive Draftsman, Kansas City Southern, Pittsburg, Kan.

The accompanying table gives the capacity for different thicknesses of plate one inch wide, and is for use in calculating semi-elliptic springs.

To obtain the required number of plates, multiply the figure given in the load column by the width of the spring in inches and divide the required capacity by the result. The quotient gives the number of plates required.

Where the quotient gives a decimal greater than three, add one plate to the whole number. The number of full length plates must be 25 per cent of the whole number required; the other plates must be regularly shortened. The deflection given in the table is the difference between the free and loaded height, irrespective of the width or number of plates. The deflection given is that under static load plus 30 per cent of the deflection for permanent set of the spring. The calculations in the table are based on a working fiber stress of 75,000 lb., and a modulus of elasticity of 27,000,000. The following formulas are used:

P = Net static load;  
 F = Deflection;  
 H = Thickness of plate;  
 L = Length between centers; then

$$P = \frac{50,000 H^2}{L}, \text{ and}$$

$$F = \frac{.000595 L^2}{H}$$

One Plate 1 in. Wide

Length between centers, inches	¼ in. Plate		⅜ in. Plate		½ in. Plate		¾ in. Plate		1 in. Plate	
	Load	Deflection	Load	Deflection	Load	Deflection	Load	Deflection	Load	Deflection
20	156	.952	244	.7616	319.5	.7680	394.5	.7744	469.5	.7808
21	149	1.050	232.5	.8396	307.5	.8460	382.5	.8524	457.5	.8588
22	142	1.152	222	.9215	295.5	.9280	370.5	.9344	445.5	.9408
23	136	1.259	212.5	1.007	283.5	1.0140	358.5	1.0204	433.5	1.0268
24	130	1.371	203.5	1.097	271.5	1.1040	346.5	1.1104	421.5	1.1168
25	125	1.487	195.5	1.190	260	1.1970	334.5	1.2034	409.5	1.2128
26	120	1.608	188	1.287	248.5	1.2940	322.5	1.3004	397.5	1.3112
27	115.5	1.734	181	1.388	237.5	1.3920	310.5	1.4004	385.5	1.4120
28	111.5	1.866	174.5	1.493	227	1.4920	298.5	1.5004	373.5	1.5128
29	108	2.002	168.5	1.601	217.5	1.5960	286.5	1.6004	361.5	1.6136
30	104	2.142	163	1.714	208.5	1.7040	274.5	1.7084	349.5	1.7144
31	.....	.....	157.5	1.830	200	1.8120	262.5	1.8164	337.5	1.8208
32	.....	.....	152.5	1.950	191.5	1.9160	250.5	1.9204	325.5	1.9252
33	.....	.....	148	2.073	183.5	2.0280	238.5	2.0324	313.5	2.0372
34	.....	.....	143.5	2.201	176	2.1440	226.5	2.1484	301.5	2.1528
35	.....	.....	139.5	2.332	169	2.2680	214.5	2.2724	289.5	2.2772
36	.....	.....	135.5	2.468	162.5	2.4000	202.5	2.4044	277.5	2.4092
37	.....	.....	.....	.....	156.5	2.5360	190.5	2.5404	265.5	2.5452
38	.....	.....	.....	.....	151	2.6700	178.5	2.6744	253.5	2.6792
39	.....	.....	.....	.....	145.5	2.8100	167.5	2.8144	241.5	2.8192
40	.....	.....	.....	.....	140.5	2.9560	156.5	2.9604	229.5	2.9652
41	.....	.....	.....	.....	136	3.1080	146	3.1124	217.5	3.1172
42	.....	.....	.....	.....	132	3.2660	136.5	3.2704	205.5	3.2752
43	.....	.....	.....	.....	128.5	3.4300	127.5	3.4344	193.5	3.4392
44	.....	.....	.....	.....	125.5	3.6000	119	3.6044	181.5	3.6092
45	.....	.....	.....	.....	123	3.7760	111.5	3.7804	169.5	3.7852
46	.....	.....	.....	.....	120.5	3.9580	104.5	3.9624	157.5	3.9672
47	.....	.....	.....	.....	118.5	4.1460	98	4.1504	145.5	4.1552
48	.....	.....	.....	.....	116.5	4.3400	91.5	4.3444	133.5	4.3492
49	.....	.....	.....	.....	115	4.5400	85.5	4.5444	121.5	4.5492
50	.....	.....	.....	.....	113.5	4.7460	80	4.7504	109.5	4.7552
51	.....	.....	.....	.....	112	4.9580	74.5	4.9624	97.5	4.9672
52	.....	.....	.....	.....	110.5	5.1760	69.5	5.1804	85.5	5.1852
53	.....	.....	.....	.....	109.5	5.4000	65	5.4044	73.5	5.4092
54	.....	.....	.....	.....	108.5	5.6300	61	5.6344	61.5	5.6392
55	.....	.....	.....	.....	107.5	5.8660	57.5	5.8704	49.5	5.8752
56	.....	.....	.....	.....	106.5	6.1080	54.5	6.1124	37.5	6.1172
57	.....	.....	.....	.....	105.5	6.3560	52	6.3604	25.5	6.3652
58	.....	.....	.....	.....	104.5	6.6100	50	6.6144	13.5	6.6192

THE SAFETY APPLIANCE ACT.—During the fiscal year ended June 30, 1913, 191 cases, involving an aggregate of 626 violations of the safety appliance act, were transmitted to the several United States attorneys for prosecution. Cases comprising 91 counts were tried in court, of which 56 counts were decided in favor of the Government. Of the remaining 35 counts originally decided in favor of defendants, appeals have been taken by the Government as to 31. The carriers confessed judgment during the year as to 448 counts. Penalties aggregating \$56,800 were collected, and additional penalties in the sum of \$19,800, in addition to costs previously assessed by the courts, were, on July 1, 1913, pending payment by the carriers.

# CAR DEPARTMENT

## STEEL TRUCK WITH CLASP BRAKE RIGGING

The New York Central is now using on steel passenger train cars a type of six-wheel truck which was designed especially for the use of clasp brakes. The truck is of all-steel construction

almost, if not quite, impossible because of the difficulty of removing and replacing the brake shoes. With the ordinary arrangement of equalizers the shoes of the clasp brakes would be directly behind them, making the work of removing and replacing shoes extremely difficult.

In the New York Central truck the equalizers are placed be-

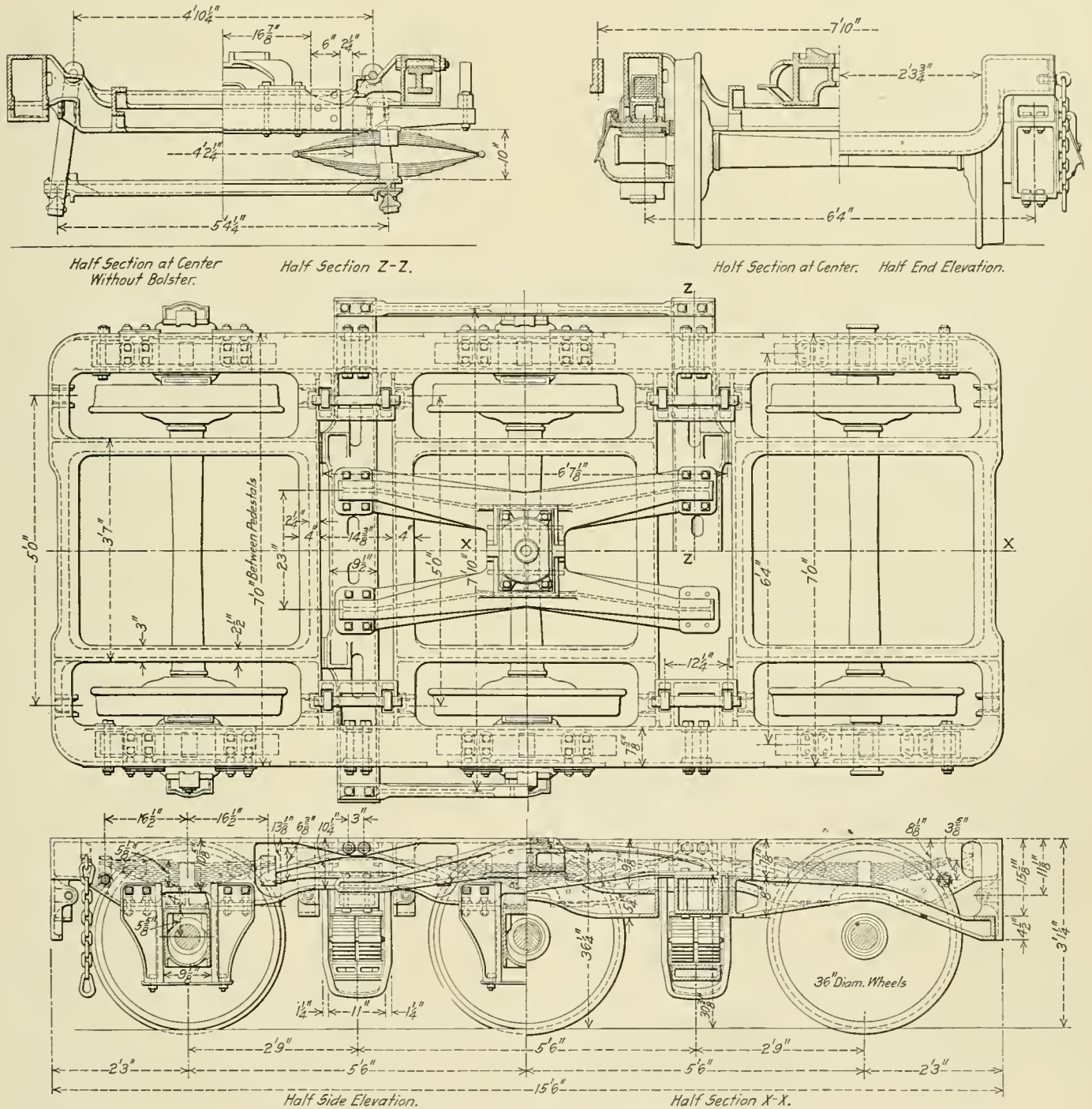

General Arrangement of New York Central Six-Wheel Steel Truck

and the principal feature is the arrangement of the equalizers. The use of the clasp brake arrangement with the system of equalization commonly used on six-wheel passenger trucks is

tween the wheels and have fulcrums in the truck frame. It will be noted that the fulcrums have two point bearings. This arrangement was used with the idea that when the equalizer





# DRAFT GEAR PROBLEM—SUGGESTED REMEDIES

## Interesting Viewpoints Developed, Emphasizing Importance to Various Departments Involved

In selecting several papers from those submitted in the draft gear competition, for publication in this issue, it has been aimed to present as great a variety of views as possible. The widely varying viewpoints which are presented emphasize strongly the importance of the problem, and while they agree in general as to the best type of draft gear to use, each one of them approaches the problem in a very different way from the others.

### FIRST PRIZE—THE DRAFT GEAR PROBLEM

BY E. W. NEWELL  
Mechanical Engineer, Pittsburgh, Pa.

Draft gear—the real meaning of which is “an apparatus used for drawing a load”—when applied to railway equipment becomes not merely a pulling mechanism, but a shock absorber as well, and owing to the limited space allotted for its installation and the short movement through which it performs its work, the design, principle of operation and installation make it one of the most important, if not the greatest problem, confronting the engineer and designer of railway equipment.

The demands of modern railroading require the stopping of a heavy, high speed train in about one quarter of one minute, but the draft gear is expected to protect from injury the coupler, the car and its lading, in one-sixth of one second at the very low speed of one mile per hour and in proportionally less time at higher speeds.

It is not our purpose to go into elaborate statistics regarding the number of cars continually out of service on account of defective draft gears and attachments, or to give figures showing the high stresses to which the draft gear is subjected, but to describe the different methods which have been used to meet these conditions and to give results of laboratory and road tests, together with car repair records in order to show which principle, in the designing of draft gears, has proved to be the most efficient.

Various means, including the compression of liquids and air, have been employed to dissipate the shocks on railway vehicles, but the only devices which have been found practical are compression springs and a combination of springs and metallic frictional members, known as friction draft gear; the comments which follow will be confined to the merits of the spring and friction draft gears.

#### SPRING DRAFT GEAR

Since the discovery of metals, springs of different forms have been used as a cushioning medium and it was natural that they should have been selected for draft gear purposes in the early days of railroads. So long as railway equipment was of light construction, the trains short, and the speeds moderate, spring draft gears were satisfactory, but as these conditions changed, the light springs were found inadequate and those of higher capacity were substituted.

The increased capacities and weights of railway equipment, together with the general use of air brakes on freight trains, permitting higher speeds and longer trains, necessitated a still further increase in the capacity of the springs, and to such an extent that disastrous results occurred from recoil. If it were not for the reactive effect, the use of springs as a shock absorber would be an ideal arrangement on railway trains, because the power required to compress a spring is in direct proportion to its movement, and this is about the rate shock stresses should be dissipated to give the best results.

The damages resulting from the recoil of draft springs is most severe on cars in transit, not only to the lading, but to couplers and attachments and other parts of the car. The danger of

parting long trains equipped with spring draft gears and running at slow speeds is so great if the throttle is opened immediately after placing the handle of the brake valve in release position, before all brakes are fully released, that locomotive engineers rarely attempt it and some roads issue instructions forbidding it.

The capacity of draft springs is limited to their safe recoil effect, which is also the capacity of the springs to resist buffing stresses; it has been found to be only about one-third the capacity of a friction gear which does not have the damaging recoil results of the springs.

#### SERVICE RESULTS

The limited capacity of draft springs gives but a comparatively slight protection to heavy equipment in buffing; this fact was very forcibly brought to the writer's attention a few years ago, when inspecting a lot of cars at the request of a railroad official. Three years previously the road had purchased five hundred cars, alike in every respect except that one-half were equipped with spring draft gears and the other half with friction gears. After having been in the same service for the above length of time, all the cars were reported to be in excellent condition. The railroad was about to purchase additional cars and contemplated using spring draft gears, as the cars equipped with this device were apparently in just as good condition as those fitted with the more expensive friction device. The cars referred to were steel hoppers and their use was confined to ore service. The steel end sills were strengthened on the outside by a very heavy steel casting extending the full width of the car, the casting being so arranged as to take the final blow of the coupler horn. An inspection of many of the cars with both types of draft gears showed them to be in excellent condition, but a visit, the following day, to the repair tracks (the best place to obtain practical draft gear information) revealed a condition which proved conclusively the superiority of friction over the spring gears.

From the repairmen the writer learned that the 250 cars equipped with friction gears were still using the couplers which were applied when the cars were built. On the 250 cars equipped with spring gears all the original couplers had been broken, as well as a complete renewal of another make and at the time of the investigation all of the spring draft gear cars, which came in for coupler failures were being equipped with still another make, in the hope that the last type of coupler would be better than the other two. They failed to realize that the trouble was due to the end sills being so strong and the capacity of the spring draft gears so low that the coupler head was continually being driven against the end sill until it broke.

If railroads would keep accurate and systematic records of expenditures and replacements of repairs to freight cars, separating the cost of draft gear maintenance from general repairs, there would be many revelations similar to this.

From experience in car design and inspection of failures of different parts of railway equipment, together with the information obtained from reading railway literature and papers before our railway clubs, there is no question (and it seems to be corroborated by all published reports), that the enormous expense of car maintenance, damage to lading, delays from break-in-twos, etc., would be materially reduced if friction draft gears, properly applied and maintained, were standard on all railways. To be more emphatic, the universal use of friction gears, would show as great improvement in conditions as the change from link and pin connection to the present M. C. B. coupler.

#### LABORATORY TESTS OF DRAFT GEARS

Much time and space could be taken by presenting figures and charts of tests of draft springs on static testing machines and



under falling weights, from the early tests under the M. C. B. drop of 1,640 lb. to the present schedule of drop and rivet shearing tests under a 9,000 lb. weight, but these results have been published so generally and are so well-known that a rehearsal of this data is unnecessary. Drop test efficiencies of spring and friction gears may be briefly summed up by the following statements, which are results of demonstrations made at various times, under the auspices of railroad officers, and which are matters of common knowledge among railroad mechanical men:

(a) A 9,000 lb. weight falling 5½ in. closes the most powerful draft gear spring solid.

(b) A 9,000 lb. weight is required to drop from 15 to 20 in. to close solid a friction draft gear of ordinary capacity.

(c) The above draft gear springs placed upon a follower, supported by two standard draft lugs, attached to channels by nine 9/16 in. rivets in each draft lug, required 15 blows of a 9,000 lb. weight falling 6 in., and one blow from a height of 9 in., to shear the rivets.

(d) A friction draft gear, under the same conditions, before shearing the same number of rivets, required:

- 15 blows of a 9,000 lb. weight falling 6 in.
- 15 blows of a 9,000 lb. weight falling 9 in.
- 15 blows of a 9,000 lb. weight falling 12 in.
- 15 blows of a 9,000 lb. weight falling 15 in.
- 12 blows of a 9,000 lb. weight falling 18 in.

#### ROAD TESTS OF DRAFT GEARS

There are many who do not consider laboratory tests of much importance, because of the conditions being so different from service. For this reason there have been made, in different parts of the country, several draft gear demonstrations, with fifty car trains equipped with spring and different forms of friction gears. The two most important tests of this kind were the Santa Fe tests at Ft. Madison, Ia., in 1906, and those on the Los Angeles division of the Southern Pacific in 1908. In order to illustrate the comparative service operation of spring and friction draft gears, a few results of the demonstrations on the Southern Pacific (see report published in serial form in the Railway Age Gazette, and the Railway and Engineering Review, December, 1908) are given below.

#### JERK TEST

Set 10 rear brakes by air, take slack with full throttle and throw reverse lever ahead; engine worked on sand. (Train: 50 cars, dynamometer car the 41st.)

Spring Gear	Friction Gear
260,000 lb. jerk	120,000 lb. jerk

#### BUFF TEST

Emergency application of the brake at a speed of 9½ miles an hour, steam shut off just previous to use of brake valve. (Dynamometer car 41st.)

Spring Gear	Friction Gear
550,000 lb. buff	155,000 lb. buff
(One broken coupler)	(No damage)

#### RELEASE TEST

Accelerate train to 20 miles an hour, then apply brakes in service application and when speed has been reduced to 13 miles per hour open throttle of engine. (Dynamometer car 26th in train.)

Spring Gear	Friction Gear
285,000 lb. jerk	156,000 lb. jerk
(Train parted)	(No damage; train kept moving)

#### BUMPING POST TESTS

In 1905-1906 a series of very interesting tests was made by a large railroad; the method employed showed in the best possible manner the inefficiency of spring draft gears. At the foot of a grade a substantial bumping post was erected, against which was anchored a dynamometer car. To the yoke of the coupler on the opposite end of the dynamometer car from the bumping post was attached a slide, containing the record paper, the buffing stresses from the striking cars being registered upon the paper, through the dynamometer, in the usual manner, the movement of the paper being co-incident with the travel of the coupler. The diagrams showed the actual operations of the gears in the same manner that an indicator card illustrates what takes place inside of a steam engine cylinder.

During these bumping post demonstrations, tests were made with loaded cars to about 3 m. p. h. and with an empty car to

7 m. p. h. and the records showed the low cushioning effect of spring gears more accurately and clearly than any laboratory or road tests could do.

#### FRICITION DRAFT GEAR

The preceding comments relating to the inefficiency of spring draft gears, disclose, in comparison, the superiority of the friction gear, which is admitted by all who have thoroughly and conscientiously investigated the draft gear question to be founded upon the best principle yet devised for dissipating the stresses to which railway equipment is subjected. The design of friction gears and the methods of operation have taken several forms, but unless some better principle than friction is discovered, friction draft gears, with possibly some modifications in design, will be used for many years to come.

Railroad mechanical men are often skeptically inclined towards the claims made by the makers of railway appliances, but it would seem that the friction draft gear manufacturers have done their part well in furnishing a device of such high efficiency, when it is considered that the spaces allowed for the apparatus are very limited and the travel (length of time for performing the work) is much less than it should be for dissipating shocks of such magnitude; and also to make it of sufficient strength, and at the same time as light as possible, so as not to increase the dead weight of the car.

The draft gear question today is one of close co-operation between the manufacturers of friction draft gear and the railroads, with especial care given to the proper installation upon cars, periodical inspections and renewal of repair parts when necessary. These suggestions, if put into practice, will undoubtedly result in more efficient service from draft gears and better protection to railway equipment and will assist greatly in answering that vital question which is worrying railroad officials so much today, as to "how to reduce the cost of car repairs?"

#### A REMEDY FOR DRAFT GEAR TROUBLES

BY GEORGE THOMSON

Master Car Builder, Lake Shore & Michigan Southern, Englewood, Ill.

What is draft gear and what is it used for? This may seem a very useless question, yet if the truth is to be acknowledged we must admit that the draft gear is one of the least understood and most abused appliances on railroad equipment. The draft gear is, to state it plainly, the cushion between the back end of the coupler and the car, and is put there to protect the car from hard knocks; therefore, the better the cushion we use the more protection we give the car, which means a reduction in freight car trouble and the cost of maintenance. At present draft gear is distinctly divided into two kinds—friction draft gear and spring draft gear—there being different designs of each kind.

Until, probably, twelve to fifteen years ago the draft gear commonly in use consisted of one or two springs having a capacity of 19,000 lb. each. These springs were attached to the coupler and car in different ways. With the old type of link and pin coupler this type of gear proved fairly satisfactory, but with the advent of the automatic coupler came the rougher and more severe handling of cars in switching service, so that it was found that a more powerful gear or cushion was needed; then springs having a capacity of 30,000 lb. were brought into use. The attachments for applying the draft gear to the cars were also improved and made stronger. While these springs gave more protection to the car, it was also found that they had a very destructive recoil, which caused a great amount of coupler trouble, such as broken knuckles, knuckle pins and coupler locks; in addition, this rougher handling of cars also entailed a vast amount of trouble in the draft gear attachments themselves, such as broken yokes, yoke rivets, center sills, draft sills, and sills, buffer blocks and broken draft timber bolts. On box cars came an increase in bulged or broken ends, leaking and damaged roofs and side doors damaged and missing—all this increase of

damage due to the more severe handling of equipment. A large amount of these troubles could have been prevented by the use of a draft gear giving more adequate protection.

Then came the steel underframe and all-steel car. On an all-wooden car the cars had some "give" to them when hit hard enough, and, while this may have helped out the draft gear, it was pretty hard on the car. With a properly designed steel underframe, or steel car, these conditions changed and the draft gear had to take the humps, as there is no "give" to the steel car.

The capacity of the cars and the number of cars per train were also increased. Heavier and more powerful locomotives came into use, so that in addition to the damage to cars and lading in switching yards came an increase in difficulties in handling long trains, such as break-in-twos, which is a very serious matter. A break-in-two means that not only the train itself is delayed while the damaged car is being switched to a side track, but it may also delay other trains, and very often cause wrecks. Men studying this question came to the conclusion that a more powerful draft gear was needed; but, while they wanted more draft gear capacity, it was preferable to obtain this without any increase in recoil; in fact, it was found highly desirable to reduce the recoil of draft gears. Therefore, this additional capacity could not be obtained by the use of springs alone for the very reason that every pound of energy used to close a spring is returned in the form of a "kick-back" or recoil.

After a great deal of experimenting, the friction draft gear was devised. In this type of gear the springs are not called upon to do all the work, as the frictional resistance is brought into use. This causes a large part of the energy delivered to the coupler by cars striking together to be used in overcoming the frictional resistance of the draft gear friction parts. Thorough tests show that, while it would take a large amount of energy to close a friction draft gear, it also has very little recoil. Friction draft gears have been tested in different ways and have proved their superiority over any and all forms of spring draft gear, this not only in laboratory tests but also in road and service tests.

Several railroads have at times fitted out test trains, equipping them with different types of draft gear, both spring and friction, and conducting a series of tests. These experiments proved beyond a doubt that the trains equipped with a good friction draft gear could be handled with greater despatch and with far less liability of break-in-twos than trains equipped with any form of spring draft gear. The shocks to which these trains are subjected due to train handling were accurately recorded by means of a dynamometer car.

The tractive effort of the locomotive has increased from the 50,000 or 60,000 lb. of several years ago to as high as 160,000 lb. on a large Mallet engine just built. A locomotive having a tractive effort of only 60,000 lb. is sufficient to close a spring draft gear solid, which leaves no cushion in the gear to take care of emergencies. All these facts tend to prove the need for a draft gear giving more protection.

The original friction draft gears had a travel of  $2\frac{1}{2}$  in., whereas the spring draft gears have only  $1\frac{3}{4}$  in. This increase in travel alone was of great benefit, and, added to the other desirable qualities of a friction draft gear, helped to solve a large number of the draft gear troubles. Since then various designs of draft gear have been placed on the market, some of them being widely used today while others had only a short life.

Manufacturers are constantly endeavoring to improve their devices until now there is at least one make of draft gear having a travel of  $3\frac{1}{4}$  in., an increase of  $1\frac{1}{2}$  in. over the travel of the spring draft gear. This manufacturer realized that a long travel was not only desirable but very effective in destroying hard blows to which the cars are subjected.

The friction draft gear has solved many troubles and it remains to be decided which make is most desirable. The friction

draft gear should have some means to compensate for slack which may occur due to wear of the parts of the device. This provision to compensate for slack should preferably be some form of adjustment which will accomplish this without reducing the length of travel, as reduction in travel means reduction of efficiency. The design of draft gear should be such that it will exclude small parts which may be easily broken or damaged. The design should not be complicated, thus making it easy for the average repair man to handle it when necessary.

The draft gear is fully as important to a car as the air brake and it would be to the railroads' advantage if they would maintain as systematic an inspection of draft gear as they do of air brakes. If air brakes were applied to the car and never looked after, how long do you suppose they would give good efficient service? Other parts of the car are regularly inspected, so why not the draft gear and thereby keep it working at maximum efficiency? A preferable design of draft gear would be one that is easy to inspect and maintain. Some designs of friction draft gear are so constructed that if anything is damaged or broken the gear is a complete loss, while in others the broken or damaged parts can be replaced and the draft gear put in working condition.

Railroads which have made a fair and impartial investigation of various draft gears have never failed to find the friction draft gear far more efficient than any form of spring draft gear ever made. Statistics of the cost of car maintenance show that cars equipped with good friction draft gears cost far less to maintain than cars equipped with spring draft gears. Some roads, in keeping the cost of maintenance covering repairs due to draft gear performance, do not go far enough, as the cost of repairs to the draft gear does not cover everything. The cost of replacing broken couplers, broken sills, yokes, yoke rivets and attachments should also be included; in fact, it is hard to tell just where to stop, as a good friction draft gear protects the whole car while a poor draft gear causes more or less damage to the entire car, particularly in case of a box car, where it is not only destructive to the car but also to the lading. It also puts a car out of service while necessary repairs are being made, thus reducing the earning capacity of the car.

A number of roads which have had wooden cars equipped with spring draft gear that were a constant source of trouble, are at present stopping this trouble by removing the old obsolete draft gear and applying either steel underframes or cast metal draft arms to the cars and equipping them with good friction gear. The roads doing this have made a study of draft gear conditions and find that, while a spring gear is probably cheaper than the friction as to initial cost, it costs far more money in the end in paying for repairs because of poor protection.

While some of the roads have looked into the draft gear question, there are a number of them which have paid very little or no attention to it. They cannot realize what inadequate draft gear is costing them until they get right down and analyze the cost of repairs due to inferior draft gear and take into consideration the total cost necessary to put a car back into service after it has been hammered to pieces by not having the necessary protection. A number of roads have kept records of these costs and after doing it there has always been one result; they have quit using inadequate draft gear and have put on the best draft gear they could buy, with the result that, instead of having cars on the repair track all the time and having congested tracks, they are keeping their cars in service where they are earning revenue instead of helping to swell the expense account.

Another question. Why do not all railroads, when buying draft gear, make an investigation as to the merits of the different draft gears and have certain requirements covering draft gear? They will inspect various articles going into the manufacture of the car, but when it comes to the question of draft gear they generally do not pay very much attention to it. There are draft gear testing laboratories in this country where the railroads are



at liberty to conduct any laboratory test they care to. These laboratories have been put up at great expense by the draft gear manufacturers, and there are at least two companies which are willing to offer their laboratories to any railroad at any time in order that they may conduct draft gear investigations. It seems, however, that some of the railroads do not realize the importance of a draft gear and what it means to them in dollars and cents. When the selection of a draft gear is left to the purchasing agent, as it sometimes is, he will generally buy the cheapest sort of draft gear regardless of the fact that this same cheap draft gear is going to cost a whole lot of money for repairs later on. Again the selection of draft gear is often made by some superior officer who is not acquainted with the different devices, and who will often go against the recommendations of his mechanical men who have made a study of the subject.

The M. C. B. Association has made many and thorough investigations of various articles used in car building, but for some reason or other has done very little along the lines of draft gear investigation. I will grant that it has made some investigations and has gathered some valuable data, but it has merely scratched the surface and has not gone deep enough. Within the past two years it has conducted a long investigation into the manufacture and design of couplers with the idea of making a stronger coupler and thus reducing the enormous number of broken couplers occurring every day. At the M. C. B. convention held in Atlantic City in 1913, various types of couplers were on exhibition illustrating ideas of strengthening them and eliminating some of the present troubles. The weight of the coupler was increased from 300 lb. to 500 lb. to overcome coupler troubles. Again we ask the question, why do not they also investigate the draft gear and see if something cannot be done there and thus help the coupler troubles by using an efficient cushion back of the coupler?

Railroads which have followed it up know that fewer couplers are broken when used in connection with friction draft gear than when used with spring draft gear. These facts are also more forcibly brought out when the records include steel cars, for as above stated a steel car has no "give" to it, to help out the poor draft gear, as is the case with a wooden car. The steel car is here to stay, so why not use all the draft gear protection possible and reduce draft gear and coupler troubles to a minimum?

### IMPORTANCE OF THE DRAFT GEAR PROBLEM

BY W. H. HAUSER

Engineer of Tests, Chicago & Eastern Illinois, Chicago

Before we can discuss draft gear intelligently we must have a proper understanding as to what is involved in the draft gear question. Just what relationship does the draft gear bear to the car? What is it designed to do for itself, or for the car? Is the whole matter of sufficient importance to merit discussion? Are there any differences resulting from the use of different draft gears? Is there enough involved to warrant any such investment of time and money as has been made to perfect the air brake, for instance?

The draft gear is very evidently placed where it is for the purpose of minimizing the shock delivered to the coupler in transmitting it to the car. It is evident that when running on a smooth roadbed, except in the case of wrecks, the car is not subjected to any damaging jolts or jars, except such as are delivered to it upon the coupler and through the draft gear. It is evident then that outside of certain normal repairs, which are necessary because of wear, on such parts as wheels, axles, brake shoes, journal bearings, or such items as painting, or air brake maintenance and lubrication, there is no car repair expense but what is directly chargeable to such shocks as are received by the coupler and transmitted through the draft gear to the car.

To thoroughly understand the draft gear and what is involved in it, it must first be appreciated that car repair ex-

pense, such as broken couplers, knuckles, knuckle pins, draft springs, draft sills, draft castings, followers, truck bolsters, oil boxes, etc., are directly chargeable to the shocks received by the coupler and transmitted through the draft gear to the car. Among breakages might be included bursted car ends, leaking roofs, loose running boards, missing car doors, bent underframes and broken end sills. Here is a damage, or a breakage, not due to legitimate wear, in which the draft gear is very evidently involved.

There is more involved in the draft gear problem than simply this breakage. Resultant upon car failures come delays to traffic and damaged lading; there is the further result of crowding of terminals, of the necessity for larger rip tracks and more repair shops. Without attempting to estimate what is involved in delays to traffic and the crowding of terminals, the expense of which, though enormous, is hard to estimate, it is possible to come to a better appreciation of what is involved in the draft gear by analyzing some of the statistics that have been published relative simply to car repair expense.

We get statistics as to what car maintenance is costing from statements issued by the American Railway Association, the Interstate Commerce Commission, and individual roads. The average cost to maintain a freight car in this country appears to be something over \$80 per car per year. Eliminating those parts of the car which wear, as being items that are not involved in the study of the draft gear, we find that a very large proportion of the car repair maintenance cost is caused by breakages. Breakages do not come from wear, but from blows or shocks. The draft gear was originally put on the car, and the supposition is that it is now placed on the car, for the purpose of preventing any disastrous results from blows or shocks which may be delivered to the coupler. Without any argument to prove just exactly how much expense is chargeable to shocks, it can safely be assumed that the car "breaks" down much faster than it "wears" out.

Recent statistics, covering eleven of the larger western roads, show that on the average each freight car of the eleven roads was repaired once a month, at an average cost per time of repair of \$6.26. This gives for the twelve months, or one year, over \$75 in repair expense. The cost of repairs on the eleven roads referred to ran from a minimum average of \$35 per car on one road to a maximum average of \$134 per car on another during the years 1909, 1910 and 1911. The average mileage per car per year ran from a little over 5,000 miles as a minimum to nearly 20,000 miles as a maximum.

These figures are interesting in showing the average mileage of cars and the average cost of maintenance for the mileage made, but in making this mileage, if these same cars were subjected simply to normal or natural wear, such as would occur on wheels, axles, journal bearings, brake shoes, or items of this kind, the average car repair expense could not possibly come within one-half of the \$75 which it cost to keep these cars in repair. Similar figures may be obtained by anyone interested, and are easily verified.

There is involved, then, in the draft gear problem, car maintenance expense to rather large and startling figures. While these figures refer only to a few roads, for only three years, other figures are easily obtainable, covering a period of eleven years. For instance, on some of the larger roads the expense of maintenance per car mile ten years ago was as low as 3.7 mills; in 1911 this expense increased to 7.9 mills, an increase of over 113 per cent. There should be taken into consideration, of course, in the increase in maintenance expense, the increase of capacity and the revenue load increase. Referring to this same group of roads, statistics show that during a period of eleven years there was an increase in freight car capacity of 34.19 per cent, and a revenue load increase of 28.54 per cent, but with it an expense of mainte-

nance increase of 67.85 per cent. The car maintenance expense in which the draft gear is not involved is certainly large enough in any one year, but the increase of the maintenance expense in which the draft gear is involved is simply appalling. It would be bad enough if we could stand still, but where is a continued increase to lead us?

Figures from 1900 to 1910 throw an interesting side light on the maintenance of equipment as compared with maintenance of way and the cost of conducting transportation. In 1900 the proportionate cost to the whole of conducting transportation was 55.04 per cent; for maintenance of way, 21.97 per cent, and for maintenance of equipment, 18.84 per cent. In 1910 the proportion was, for conducting transportation, 50.29 per cent; for maintenance of way, 20.22 per cent, and for maintenance of equipment, 22.66 per cent—a decrease in the first two items, but a decided and large increase in the last item, that of maintenance of equipment.

To cite an individual case, the cost of maintenance of way and structures on one of the large railways for the calendar year 1910 was \$20,342,488. The total cost of conducting transportation was \$57,200,886. The ratio of maintenance of way to cost of transportation was 35.56 per cent. It constituted 17.71 per cent of the total operating expense, and took 12.67 of the total operating income. Maintenance of equipment cost \$31,117,989 and its ratio to expense of conducting transportation was 54.27. It constituted 27.1 per cent of the total operating expense, and it took 19.38 per cent of the entire operating revenue of the road. Repairs and renewals of locomotives cost \$3,612 per locomotive. There were 3,426 locomotives—hence the entire expense of maintaining them was \$12,375,605. This was \$2,277,038 more than the cost of all the fuel they burned. It averaged 12.79 cents per mile run. Maintenance of freight cars cost \$13,840,087, or \$99.08 per car. The total cost was \$3,741,526 more than the total cost of fuel burned in locomotives. The total freight car mileage was 1,172,687,533. The cost per freight car mile was therefore 1.18 cents.

To run a freight train of fifty cars a hundred miles cost as follows:

Locomotive maintenance .....	\$12.97
Fuel .....	10.44
Freight car maintenance.....	55.00

In other words, it cost to maintain the freight cars in the train more than two and one-third times the cost of fuel and locomotive maintenance combined.

Take twenty-two of the larger roads and the expense of repairing freight cars in the two years 1910 and 1911. These figures are easily available and their accuracy is not in question. In 1910 the average capacity of the freight cars on these roads was 35 tons, in 1911 the average capacity was 35.9 tons, an increase of 2.6 per cent, but the average number of tons of revenue freight per loaded car was in 1910, 20.2 tons, and in 1911, 20.14 tons, a decrease of 0.3 per cent. The total cost of maintenance expense of the freight cars on these twenty-two roads for 1910 was \$64,516,474. In 1911 the same expense was \$78,841,349. The cost of maintenance of freight cars per mile run in 1910 was 0.71 cents, and for 1911, 0.90 cents, an increase of 26.75 per cent.

Again it becomes most apparent that there is a great deal involved in the draft gear problem. It is not the wear to freight cars that is costing money—it is the damage to freight cars that is piling high the expense. The damage comes, not from the wear upon the coupler, but from the blow upon the coupler, and from the fact that the blow upon the coupler is transmitted through the draft gear to the car. It is very evident that the blow should not be transmitted, but should be absorbed in the draft gear, even at the expense of the draft gear, as it is a self-evident proposition that it would be very much cheaper to repair draft gears than it is to repair cars.

A more recent analysis of the freight car maintenance record over a period of ten years for thirty of the leading railroads, giving in detail the number of car miles and the total expense, shows the cost per mile run in 1902 to have been 0.569 cents; in 1912 to have been 0.918 cents, an increase of 61.3 per cent. During that period the average capacity of freight cars in service increased 33.46 per cent and the average number of tons of revenue freight per loaded car mile increased 21.63 per cent. On the basis of the ton mile there is an increase of 39.15 per cent in the cost of freight car maintenance. These same figures show that the highest cost per ton mile is 1.223 mills, and the highest cost per car mile is 1.390 cents. Cost for maintenance of equipment, 100 tons, 100 miles, on a group of four roads was in 1902, \$4.44; in 1912, \$5.72. On another group of four roads in 1902 the cost was \$4.70, as against \$7.19 in 1912, an increase of 52.98 per cent. On a group of ten roads where the cost was \$7.53 in 1902, it was \$10.15 in 1912 an increase of 34.79 per cent. A bulletin of the American Railway Association of a few months ago showed an average of 6.93 per cent of the freight cars in the repair shop.

There seems to be no question from the mass of authentic statistics available that car maintenance expense is upon the increase and is increasing more rapidly than are the expenses in any other department of railroad operation. As a large proportion of the car repair maintenance expense is not due to simple wear of parts, but to damage of parts, and as damage comes from blows or shocks, and as blows or shocks should be minimized in the draft gear, there seems to be but one conclusion, and that is that the draft gear and what is involved in it is a matter of tremendous importance. The millions of dollars of car repair expense can be very greatly reduced by the reduction of damage resultant from shocks in railway operation. The reducing, minimizing or eliminating of shocks is something which should be taken care of in the draft gear. It becomes then a very important matter in the purchasing of draft gear to select a type which, under test, shows the highest capacity with the least recoil.

#### THE SO-CALLED DRAFT GEAR PROBLEM

BY MYRON E. WELLS  
Ann Arbor, Mich.

From an economic standpoint the draft gear problem is certainly most important. W. E. Symons, before the Western Railway Club, made a very reasonable estimate of the annual cost of repairs to freight cars that occur through the draft gear alone, and placed the figure at approximately ninety million dollars. This does not take into account the loss and damage claims, the cost of switching bad order cars to and from the repair track, the delays to traffic and the consequent overtime. It is also a most important factor in keeping the average daily mileage of freight cars down to the very low figure of twenty-five miles a day. This, to my mind, is a great source of lost efficiency, and one not usually taken into account.

The combined effect of all these handicaps results in greatly reducing the efficiency of the railroads. When all these matters are carefully considered and taken into account, the recent estimate quoted by the Railway Age Gazette of two hundred and fifty million dollars' damage per annum caused by draft gear troubles is not far wrong. At any rate any efforts to solve the problem are certainly worth while, and I am very glad to add my mite, because I have for a good many years held some very positive ideas on the subject.

It is already well known that the modern type of friction draft gear is the best and most efficient so far produced. Understand, I am speaking of the type in general, and not any particular make. And with this improvement in friction draft gears we have advanced some, but the problem of reducing the expense of car repairs is still unsolved.

I want to ask, in this connection, why is there this distrust



as to the work of our mechanical men along the lines of improved draft gears? No one is offering prizes for data to show that the locomotives and cars of the present day are an improvement over what we had ten and twenty years ago, because that fact is beyond question; so, also, is the fact of the present improved friction draft gears. Our railroad mechanical men are a valiant lot. They are usually equal to any emergency. They have made wonderful strides in improving locomotives and cars generally, but their work on improved draft gears is questioned and in grave doubt, so much so that it is now asked, What have they done? Is there any real improvement, and what is now the most efficient type of draft gear?

On the improvement of any particular mechanical problem the effort put forth, and the improvement made, is usually in proportion to the necessity for improvement; and of all the important necessities in modern railroading none has called louder or been more persistent than the one that has asked for an improved draft gear. My private opinion is that this has been well met by our mechanical men, and, considering the limitations under which they have been compelled to work, they have done nobly in producing the present friction draft gears, and their efforts are to be commended rather than questioned and criticized. If there is anyone who doubts the efficiency of the present friction draft gears I would ask him to not only read, but study carefully, first, the tests of a committee of the Master Car Builders' Association reported in 1908. Second, the actual road tests on the Southern Pacific Railroad, published in the Railway Age Gazette of January 8, 1909. Third, the facts and figures presented by J. C. Fritts on this subject at the September, 1913, meeting of the Central Railway Club.

If they will take the trouble to go over this evidence carefully I do not understand how they can still continue to doubt. As for myself I am thoroughly convinced, not only from the facts cited, but from personal experience, that modern friction draft gears do absorb shock; and the Master Car Builders' tests show that draft gears after from one to five years' actual service were equally efficient with the new in absorbing the shock.

Perhaps a large share of the distrust in friction draft gears comes from the fact that the method of absorbing the shock by friction is sort of paradoxical and hard to understand. It is also most clearly shown that these modern friction draft gears do away with practically all of the shocks from recoil, and if they did only this one thing they would still be enough better than the old spring gears to warrant their substitution. That, in a general way, they are stronger and more efficient is shown most clearly and emphatically by Mr. Fritts' figures. It must be remembered that our mechanical men, in dealing with the draft gear problem, have had to stay within the limitation of 2½ in. or 3 in. travel, and have had to build the drawbars inside of the limitation of one square foot. With these limitations they have done as well as could reasonably be expected. If you could give them a 5 in. or 6 in. movement instead of 2½ in. or 3 in., they could make the friction plates take up much more shock. Also if they had five or six square feet instead of one square foot, they could build a stronger drawbar. But this first is out of the question because you could not then keep the air hose coupled, and in the second case you would complain of the increased expense.

Is there then a solution of this problem? Surely there is. But it is not to be found, in my opinion, along the lines of your suggested competition, nor in finding the most efficient type of draft gears. The solution of the problem is not mechanical. The remedy lies with the operating official in stopping the outrageous and unwarranted destruction of cars in our switching yards.

#### BETTER OPERATION NEEDED—NOT BETTER DRAFT GEARS

Mr. Fritts, of the Lackawanna, in classifying the damage done to draft rigging, places it in the following order: First, damage on the road because of the introduction of heavier power and larger trains; second, the switching of light and heavy cars to-

gether; third, and he says the most important, is the starting of trains and taking slack. Under this head he mentions as a suggestion that cars are sometimes damaged in switching yards. I do not like this classification, and I am going to put the switching of cars in yards as the one great cause of most of our drawbar trouble. Cars are damaged in yards 20 to 1 for those damaged on the road, and my proof for this is the difference in the trouble in maintaining the draft gears on yard and road locomotives.

In road work practically all of the work is done on the tender drawbar. Any roundhouse foreman can tell how long an average tender draft gear will last in the average switching yard. The fact of the matter is that they do not last at all; and for this reason you will find all yard locomotives doing the work with the front end. Not only this, but you will find that the front ends of yard locomotives have been wonderfully strengthened beyond anything possible on an average tender or car. The extension frames have been shortened and made much heavier; in some cases a large cast steel filling piece is placed between the frames to add strength. Then it has been found that the ordinary front-end timber is entirely inadequate, and this has been replaced by a cast steel member, and even then the roundhouse foreman's troubles are not over in maintaining it.

The necessity for switching from the front end of yard locomotives is so great that in some cases the reverse lever has been changed to the left side of the locomotive in order that the engineer may be on the inside of the curve in some yards where a large amount of switching is done. And while there is all this trouble with yard switching engines the roadmen are going along day after day doing all the work with the drawbar on the tender, with very little drawbar trouble.

During a six months' period recently I rode thousands of miles on freight trains on a trunk line railroad; and in that time no train I was on pulled out a drawbar, and I received but one severe shock, and this did not damage the drawbars to make a delay. In a large majority of cases where drawbars are pulled out on the road the initial damage was done in some switching yard. In this connection I want to speak of the work done by the Air Brake Association and the Traveling Engineers' Association in reducing the shocks in road work. They are entitled to a great deal of credit for the work that has been done; and yet practically nothing has been done to decrease the shocks in switching yards. In fact I sometimes think that the stronger and more efficient the draft gears become, the harder the switchman persists in throwing the cars together.

Mr. Fritts in his report says that from 70 to 80 per cent of the drawbar damage was due to shock, and he further adds: "If this monster shock is responsible for so great an expense to the railroads in general, and we all know that it is, what should be done to relieve the equipment of the ravages of this demon?" Do we all know that this "monster shock" is responsible? For myself I have known it for years, and I believe with Mr. Fritts that every railroad man in this country knows it also, and if this is true, and we have the courage of our convictions, why can not the problem be solved?

Operating officials have side-stepped it long enough by making themselves believe it was a mechanical problem. So far as I am concerned, the whole object of this paper is to answer Mr. Fritts' one question, and the answer is very simple. The solution of this so-called draft gear problem does not depend upon any particular type of draft gear. It is a matter of stopping the present methods of switching in our yards. A solution of a very large percentage of the trouble will be accomplished when operating officials cut the speed of switching operations in yards. I know on practically all the railroads in this country that the switchmen are supreme in the matter, but the officials must take a stand and stop the destruction.

To back this argument I want to cite that the Pennsylvania Railroad some five or six years ago issued an order limiting the speed of switch engines to two miles an hour, and it is well

known that the Pennsylvania road is leading in this matter, and that it has some very rigid rules, and that it is actually stopping in a great measure rough switching in yards. In most yards five miles an hour is considered slow switching, and four cars cut off at one time is a reasonable average. These four cars, loaded, weighing approximately 600,000 lb., striking other cars at five miles an hour, develop over a million foot pounds of energy, and this shock is more than any draft gear can possibly be made to stand, friction or otherwise.

Locomotive boilers are built on a factor of safety of four. What would you think of the sanity of a man who would allow 800 lb. of steam put on a boiler that was made to carry 200 lb.? This seems a very silly question, yet you are allowing your draft gears on cars to be mistreated as badly as this every hour of the day and night. If there is a general manager who doubts my statement he can convince himself by spending a few days and nights in some switching tower watching the actual work. To get his full money's worth he must make sure his presence in the tower is not known to the switchmen.

I believe you will all agree with me that any time now gained in *hurry-up* switching is more than lost in the extra switching of the bad order cars produced by the *hurry-up* methods. But whether this is true or not makes little difference because cars cannot be made to withstand the shocks they get, and I know of no solution but to cut out the shock.

All of this expense and destruction to the freight cars does not take into account the millions of damage claims paid annually on account of rough switching. The Santa Fe has a special committee working to reduce the damage claims, and it is spending much time on methods of loading and schemes of fastening freight in cars so that it cannot move, etc. This is all very good in a way, but if it really wants to accomplish much in a short time I would suggest that it join forces with the mechanical officials, and go in a body to the operating officers and persuade them to issue some kind of an order that will stop the rough switching in yards. It will save them millions annually in both freight car repairs and in freight claims, even after they have put on a few more switch engines and crews.

Most railroads handle their passenger equipment in a reasonable manner, and I have maintained for a good many years that no general manager would go wrong if he ordered all freight cars switched in the same way that passenger cars are usually handled. If we are really convinced that this problem is no longer mechanical, and that the large amount of money spent annually for car repairs and freight claims can be reduced by stopping the outrageous switching methods in our yards, then will the so-called draft gear problem be solved.

**RAILWAY COMMUNICATION WITH THE ISLE OF WIGHT.**—The Isle of Wight Chamber of Commerce has passed a resolution expressing the view that a train ferry either from Stokes Bay to Ryde or across the Solent would be a more practicable scheme than the projected Solent tunnel between the Isle of Wight and the mainland.

**THE TANGANYIKA RAILWAY OF GERMAN EAST AFRICA.**—The Tanganyika Railway is a meter gaged line owned by the East Africa Railway Company which was recently completed from Dar-es-Salaam on the Indian ocean across German East Africa to Kigoma on Lake Tanganyika. The most important locomotives used on the line are of the consolidation type. They burn wood almost entirely and have an inside heating surface of 1,372 sq. ft., and a grate surface of 28 sq. ft. The locomotives have 40 in. diameter driving wheels, 17 x 21 in. cylinders and a weight in working order of slightly over 101,000 lb. They are capable of hauling a load of 500 tons on level track, but on one division where constant grades of 1.6 to 1.8 per cent. are met with for a distance of about 25 miles, the weight of the train has to be reduced to 260 tons. The sharpest curve met with on the line has a radius of 850 ft.

## DAIRY REFRIGERATOR CAR

The latest design of refrigerator car built by the Milwaukee Refrigerator Transit & Car Company contains many interesting features that are original with the builders. The car illustrated herewith has a rated capacity of 60,000 lb., and weighs ap-



Applying Hot Asphaltum to the Car Floor

proximately 41,500 lb. This design is used for either beer or dairy traffic with but few modifications. The superstructure is entirely of wood, while the underframe is made up of both wood and steel members. The steel portion of the underframe is made up of two 9 in., 20 lb. channels for center sills spaced

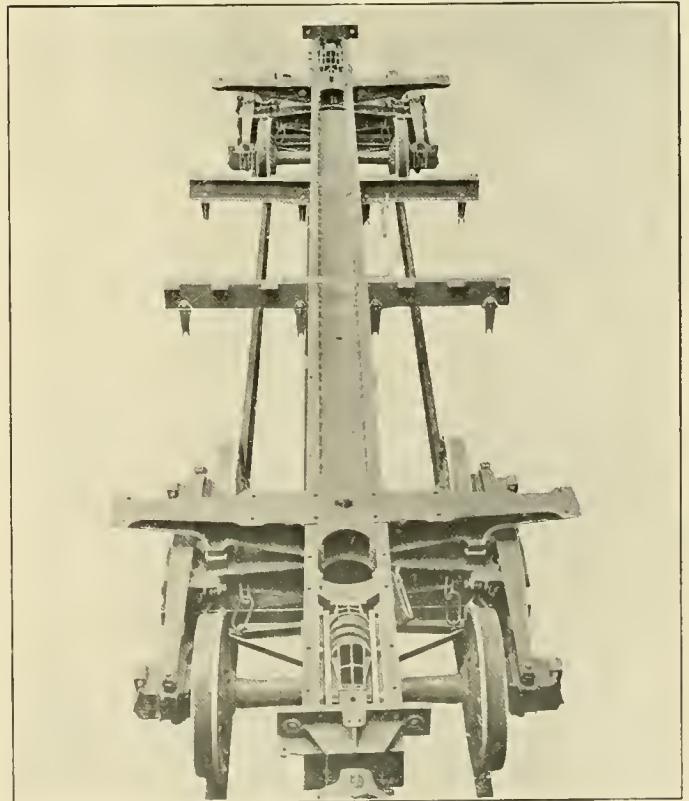

Steel Underframe for the Refrigerator Car



13 in. apart. A 13 in., 32 lb. channel is riveted to these channels forming the bottom chord to the center sill girder. A needle beam is located 3 ft. 5 in. on each side of the middle of the car, and there are four truss rods extending the full length of the car, and anchored in the end sills. The needle beams are 9 in., 13.25 lb. channels, and are fastened to the center sill channels by angles. In addition to these a 1/2 in. plate, 3 ft.

The superstructure is entirely of wood. The roof is composed of two layers of 13/16 in. roofing boards with a layer of plastic roofing between. The siding consists of 13/16 in. outside sheathing, with 13/16 in. inside sheathing on the sides, and 7/8 in. on the ends.

One of the interesting features of the flooring is the trough in the center for draining the moisture from the floor. This trough is formed in a board set flush with the wooden center sills, and is covered with galvanized iron which is lapped over

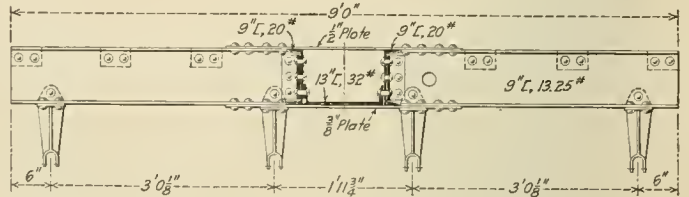
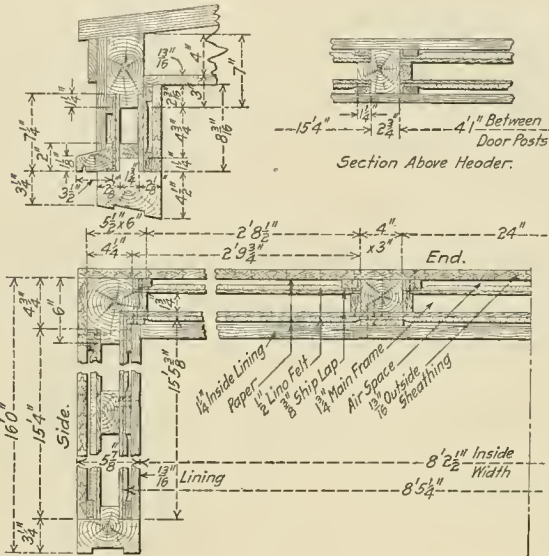

Cross Section Showing Connection Between Needle Beam and Intermediate Draft Sill

the sub-floor, as shown. Outlets are provided at both ends of the car just in front of the ice boxes, the drain pipes extending down through the insulation and center sill. The floor is made on an angle so that the water will readily drain into the trough, and oak floor strips are placed transversely the full length of the car.

The insulation is clearly shown in one of the illustrations. It will be noted that the insulation in the corners is well lapped

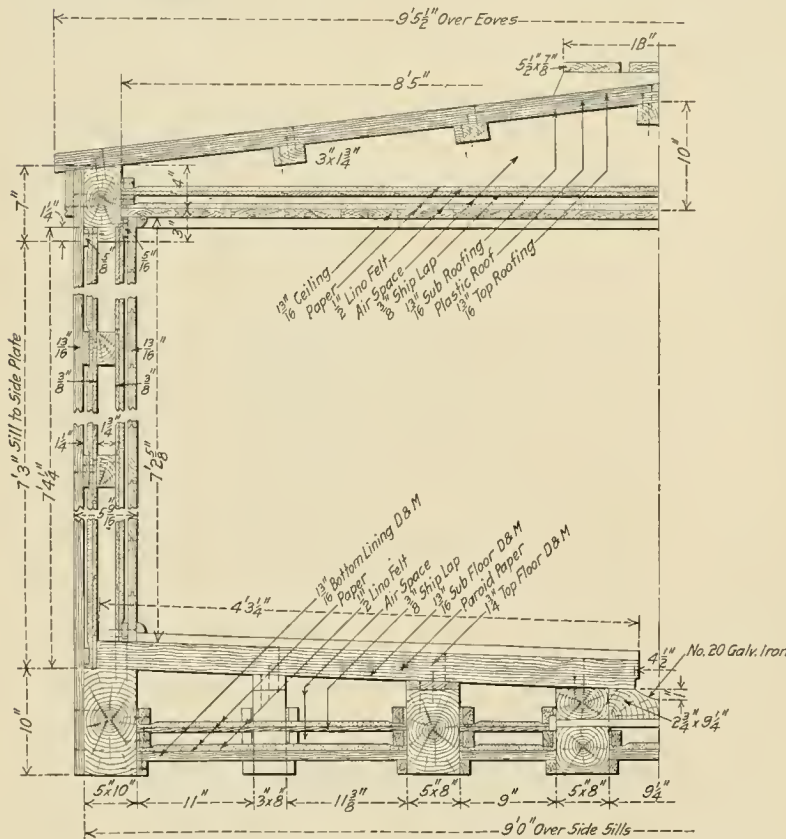

Insulation Details of the Milwaukee Refrigerator Transit & Car Company Dairy Car

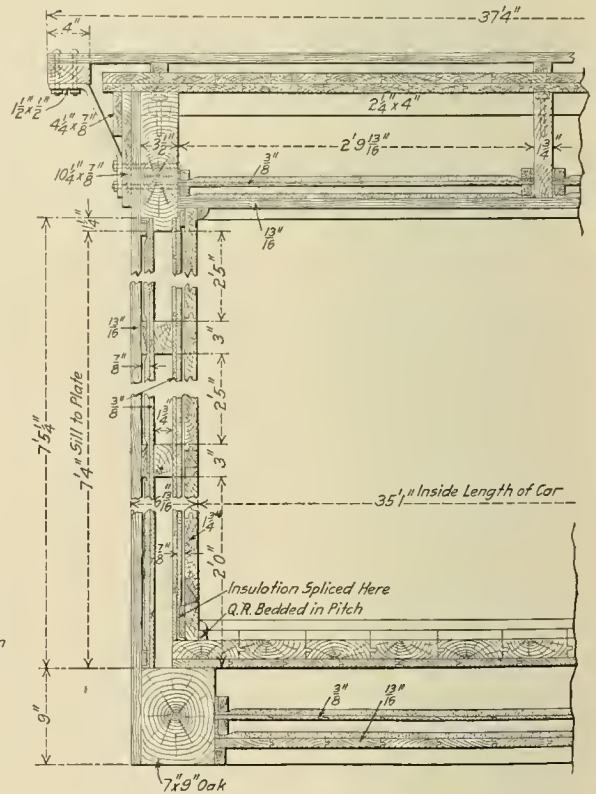

3 in. long and 3 in. wide, is riveted to the top flange of the channels extending across the top of the center sills, and a 3/8 in. plate of the same dimensions is riveted to the lower flanges of these channels, extending across the bottom of the center sills. The wooden sills of the underframe, of which there are eight, including the side sills, are bolted to the needle beams by 3/4 in. bolts.

around nailing strips to insure a heat tight joint. The felt insulation on the inside of the car extends clear around the car in one piece, and the two layers in the ceiling extend across the car between the carlines. The sub-floor is covered with a hot asphaltum compound, and all the corners around the framing are filled as shown in one of the photographs. This not only seals the joints from the transmission of heat, but also provides

a waterproofing which is very necessary with this type of car. Special attention has been given the construction of the ice boxes in the dairy cars. The ice hatch is substantially built with heavy blocking on all four sides to prevent its being knocked out of shape, and thus injuring the insulation. The

bulkhead. These strips are so covered to prevent undue abrasion, and to make it impossible for thieves to cut through the bulkhead into the car.

The principal dimensions of the car are as follows:

Length over end sills.....	36 ft.
Width over side sills.....	9 ft.
Length inside.....	35 ft. 1 in.
Width inside.....	8 ft. 2½ in.
Distance between bulkheads.....	29 ft. 1½ in.
Length of ice box.....	2 ft. 4¾ in.
Height of ice box.....	5 ft. 9¾ in.
Width of ice box.....	8 ft. 2½ in.
Capacity.....	.60,000 lb.
Weight.....	.41,500 lb.

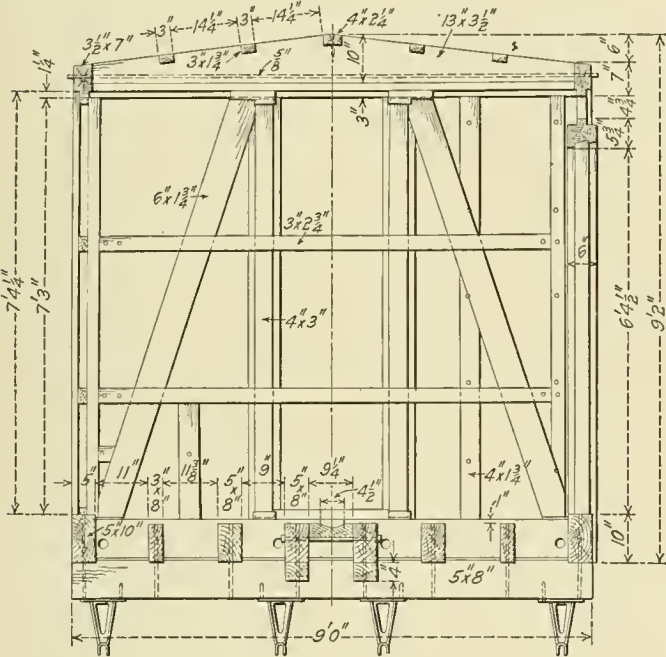

Details of the End Framing

bulkhead is made up of five 5 in. by 3½ in. oak posts, to which are applied horizontal 4 in. by 1¾ in. boards spaced 2 in. apart on the outside, and 1 in. diagonally cut strips on the inside. The ice bars are 4 in. by 1¾ in. oak, and are made in four sec-

## PACKING AND LUBRICATING JOURNALS\*

BY G. J. CHARLTON

General Foreman, Car Department, Delaware, Lackawanna & Western, Buffalo, N. Y.

The waste employed in lubricating car journals should be of a good quality of wool, entirely free from grit or dirt, and also from any objectionable material that is at times found in the waste as furnished from the market, such as needles and other foreign substances which may not be readily observed, but which contribute to bringing about a hot box. In the preparation of packing, care should be taken to see that the quality of oil prescribed for summer or winter season is used accordingly, as failure to observe this at the change of season will cause trouble. This is all a matter of common sense, the lighter oil being used in cold weather, when its density is increased and it produces the same condition as the heavier grade in the warm weather. The weather conditions in both instances act as an agency of proper distribution and assist in maintaining the proper percentage of oil in the waste over the entire journal box.

The waste and oil should be mixed in the proportion of 80 lb. of waste to 90 gal. of oil, to insure a thorough saturation of the waste. This mixture should stand for 48 hours in a room in which the temperature is kept at from 68 to 70 deg., after which 50 gal. should be drawn off, leaving the ingredients in the proportion of 1 gal. of oil to 2 lb. of waste or 4 pt. of oil to 1 lb. of waste. These proportions may appear to make the packing somewhat dry, but my experience is that they bring the best results. A greater amount of oil than this is useless, as this mixture gives ample lubrication.

In the entire repacking of journals when cars are passing through the shops or over repair tracks, the treatment should be different from that given to loaded cars lined up for train movement. First, remove all the packing from the journal box and clean out the box thoroughly, leaving no particles of grit or dirt. All of the packing removed should be taken to the reclaiming plant and worked over, as will be explained later. Next take a handful of new packing and twist it to the form of a rope so that it will fit in the back of the journal box and form a dust guard as well as a filler; then fill the box to the center line of the length of the journal, the centering hole in the end of the journal serving as a guide to the proper height, keeping the packing inside of the journal collar and seeing to it that the box is not too tightly packed. Place one piece of packing in front of the journal as a wedge to keep the packing on the sides in place; this should have no connection with the packing on the sides or under the journal. See that no loose ends of packing hang out, as they will draw the oil from the box.

Filling the box to the center of the journal is important, as packing lying above that point is apt to be caught and drawn between the journal and the bearing, producing friction which results in numerous hot boxes on account of its action in hardening the material in the journal bearing.

A box thus packed should be in condition for six months\*

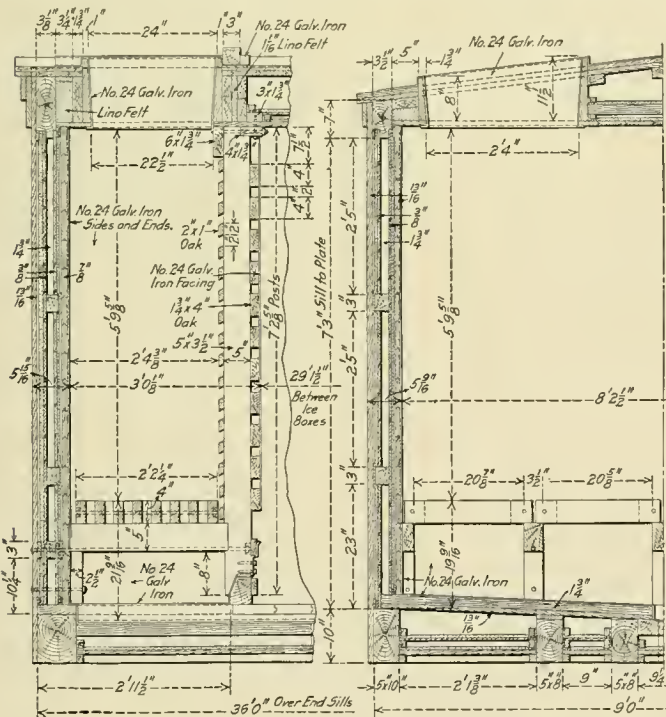

Arrangement of the Ice Box

tions across the car. They are supported by blocks extending from the bulkhead to the sheathing, as shown in the illustrations. The inside of the ice box is covered with No. 24 gage galvanized iron, as are also the strips on the outside of the

\*From a paper, presented before the Niagara Frontier Car Men's Association, Buffalo, N. Y., May 18, 1914.



service. In being placed in train service it should receive the following treatment about every 400 miles: Adjust the packing, removing any from the side of the journal that may have become dry and unserviceable, and bring the well saturated packing from the bottom of the box up to the journal. Be careful that the packing on both sides of the journal is not beyond the proper limit of height, and is all on the inside of the journal collar. The part removed from the sides of the journal, or some of it, may now be replaced in front of the journal as a wedge and should have no connection with the packing under the journal.

This system if closely followed will produce satisfactory results and reduce hot boxes to a minimum, but of course circumstances over which we have no control or at least very little control will always be the cause of more or less trouble. From reports of the hot boxes on the Buffalo division of the Lackawanna for 30 consecutive days the hot boxes on foreign equipment are shown to have been 82.7 per cent and on home equipment 17.3 per cent.

Over a longer period and comparing the number of hot boxes with the mileage made on freight trains, we have for the year ending October 31, 1913, a total mileage of 272,388, 146 and a total of 5,274 hot boxes, or a mileage of 51,837 to one hot box. For the same period there was a passenger mileage of 43,165,465, and a total of 79 hot boxes, or a mileage of 546,398 to one hot box.

The reclaiming of the packing previously referred to is done by pressing out the oil, picking over the packing, removing the dirt and grit as much as possible and then placing it in a reclaim tank where it is steamed for 12 hours to remove any further dirt and grit and restore the elasticity. It is then pressed and 200 lb. of old packing are mixed with 40 lb. of new waste saturated with 70 gal. of oil and allowed to stand 24 hours, after which 50 gal. of oil are drawn off, leaving the reclaim consisting of 10 gal. of oil to 120 lb. of waste. This makes a packing as good as new.

Certain other points come in immediate relation to the proper method of packing and, if given close attention, will help to keep the packing in good condition and assist in the prevention of hot boxes. One of these is the dust guard, which should be watched carefully and maintained in normal condition. The journal box lid should be in place and the fitting and tension maintained. This will prevent as far as possible dirt from entering either the front or back of the box.

There are causes of hot boxes which cannot be traced to lack of lubrication, such as hard roadbed and low and high joints. The latter cause trouble in boxes that have not been treated for some time and the packing having become soggy will not return to its former position in the box after being pushed down by the action of the journal.

Care should be taken in renewing journal bearings to see that they have a proper crown bearing. The journal wedge should not be too tight on the bearing, as it will pinch the bearing to the journal, causing the edges of the bearing to prevent the entire lubrication, and if it is too loose it will permit too much crown bearing, causing a tendency to break the journal bearing by a concentration of weight on the crown. A factor that should be kept in mind is the great care to be taken in the changing of wheels on repair or shop tracks, more especially on cars used for high class freight, as these cars are intended for fast movement and hot boxes on them involving delays invite more than ordinary criticism. The writer believes that the number of cars heating immediately after such work could be reduced to a minimum if special care were given at the time of doing the work to see that the boxes were properly packed. At the present time when piece work is predominant and the money earned the chief object in the view of the men, this feature cannot be brought too strongly to the attention of the foremen.

In the handling of wheels for shipment to and from the

wheel press, and in fact from the supply track to the car under which they are to be used, and in the removal from the car, the men engaged should be instructed to see that the journals do not become marred or dented. This is quite apt to occur and the condition likely to pass unobserved, and wheels applied in such condition are a source of hot boxes.

The filled journal bearing should not escape attention. Earnest efforts have been made by the Master Car Builders to eliminate them and not the least reason for doing so is the fact that it is impossible for a car inspector to obtain even a reasonable knowledge from the exposed end of the bearing of the extent to which they are worn. Of the hot boxes developing on freight trains on the line of the Delaware, Lackawanna & Western between Buffalo and Binghamton during April, 1914, 55 were caused by filled journal bearings on foreign equipment. This will be appreciated when we consider the few lines using these journal bearings, showing that a large percentage of them develop hot boxes.

### STEEL STEPS FOR PASSENGER CARS

The Canadian Pacific is using all-steel steps both on steel and wooden passenger equipment. The accompanying illus-

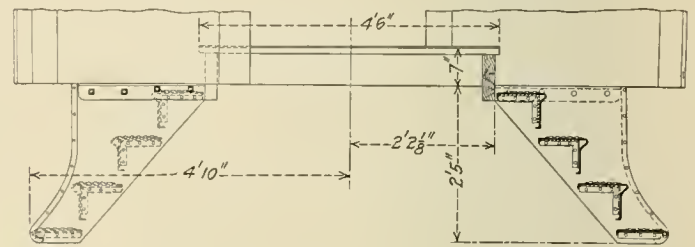

Application of Canadian Pacific Steel Steps to a Passenger Car

trations show the design of these steps in detail as well as the application to the car. The step and the riser are made in one piece and are connected to the end pieces by means of 1/4 in. by 1/4 in. by 1/8 in. angles. These angles are spot

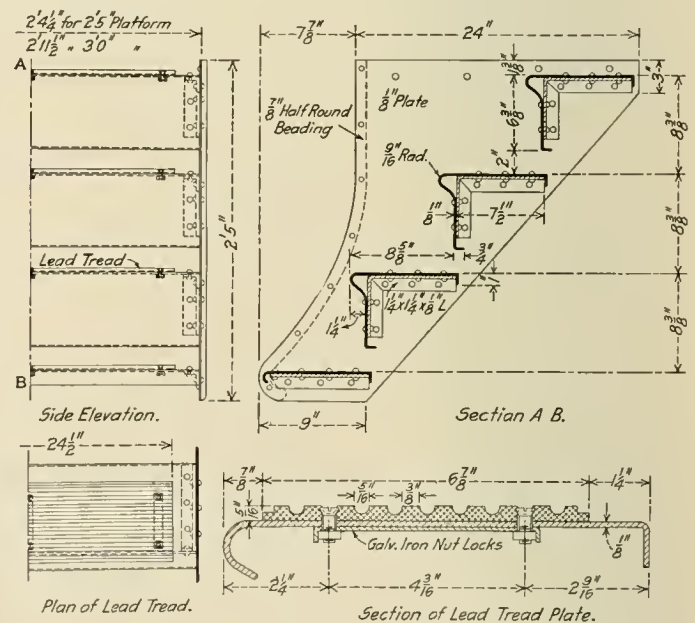

Details of the Canadian Pacific Steel Steps

welded to both the step and riser and the end pieces. The practice originally was to make these connections by means of rivets, but it is now done entirely by means of spot welding. The end pieces are 1/8 in. plate reinforced at the outer edges by 7/8 in. half round beading. Lead tread plates are used and held in place by bolts as shown.

# SHOP PRACTICE

## HOT WATER BOILER WASHING SYSTEM

BY E. A. MURRAY

Master Mechanic, Chesapeake & Ohio, Clifton Forge, Va.

A hot water boiler washing and filling system was installed at the Clifton Forge shops of the Chesapeake & Ohio about two years ago. It serves 25 stalls in two roundhouses and its operation has been very satisfactory. It has decreased the amount of coal used in firing up by about 1,200 lb. per locomotive; at a large terminal this alone is an important item. A decided decrease in the cost of boiler repairs, due to the reduction in flue leakage, broken staybolts and cracked fire-box sheets, has been observed since the system was installed. Another important benefit is the saving in time required to turn engines. From two to three hours less time per engine is required than with the old method of washing and filling with cold water.

The system is shown diagrammatically in one of the illustra-

placed at such a height that the blow off line has a very appreciable pitch downward from the blow off main in the roundhouse, thus effectively draining this line of all condensation. The water flows from the blow off tank into the sludge tank, slowly passes up through the settling tank, and overflows into the washing tank. It is impossible for steam to pass into the washing tank, because the drain pipe from the blow off tank is always submerged in about 10 ft. of water. A suitable valve is provided for discharging sediment collected in the sludge tank. The pumps take water from the washing and filling tanks through 8 in. suction lines, the level of the water in these tanks being high enough above the pumps to give a good head. A thermostatically controlled valve admits sufficient cold water to the suction line of the washing pump to cool the water to a temperature of about 125 deg. Fahrenheit. The temperature of the water in the washing and filling lines in the roundhouse is kept constant by means of the small circulating lines. Steam separated from the water in the blow off tank passes to the feed water

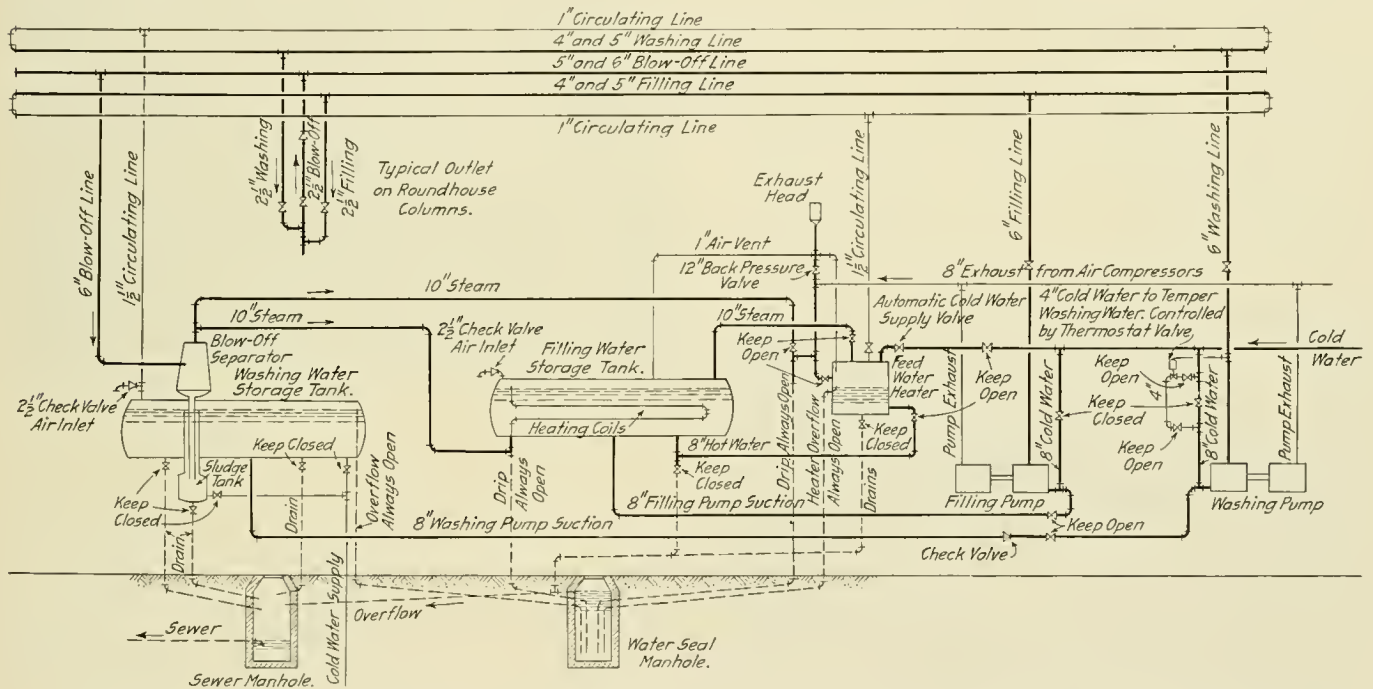

Diagram of the Hot Water Boiler Washing and Filling System at the Clifton Forge Roundhouse of the Chesapeake and Ohio

tions. The principal elements are a conical blow-off tank, 3 ft. 6 in. in diameter at the top, 5 ft. in diameter at the bottom and 7 ft. high; one washing tank and one filling tank each 8 ft. in diameter, 30 ft. long and having a capacity of 10,000 gal.; a 3,000 horsepower open type feed water heater; a sludge catch basin; a water seal manhole, and two 16 in. by 10 in. by 12 in. duplex pumps, one for washing and one for filling. The piping system between pump room and roundhouse consists of a 6 in. washing line, a 6 in. filling line, a 6 in. blow off line and two circulating lines. Drop lines of 2½ in. pipe are connected to the blow off, washing and filling mains between stalls. These three lines are brought down the building columns and arranged for hose connections.

Water and steam from the locomotive boilers pass to the blow off tank where, aided by the centrifugal force, the steam is separated from the water. The blow off tank is

heater through a 10 in. pipe. Uncondensed steam from the heater passes on to the filling tank through a 10 in. pipe, where it is utilized in maintaining the temperature of water in this tank. Exhaust steam from the air compressor which is not used for other purposes, together with the exhaust from the washing and filling pumps, and steam from the blow off tank, are collected in a common pipe line and made available for heating water not only for use in filling locomotive boilers, but for feeding the stationary boilers as well. Any oil in the exhaust from the air compressor is removed by an oil separator in the exhaust line. The feed water heater is provided with an auxiliary oil separator, which tends to remove any trace of oil still remaining in the steam. A portion of the steam from the blow off tank is discharged through a 10 in. pipe to the bottom of the filling tank. In this tank is a bank of six 4 in. pipes running twice the length of the tank, with their free outlets about 4 in. above the maximum



water level in the tank. The function of these pipes is to maintain, or still further increase the temperature of the water in the filling tank.

Water for filling locomotives, as well as feed water for the stationary boilers, is obtained from the filling tank, which is supplied from the feed water heater through an 8 in. pipe. The steam pressure in the filling tank and the feed water heater is equalized by a 10 in. pipe, hence the level of the water in the filling tank and feed water heater is the same.

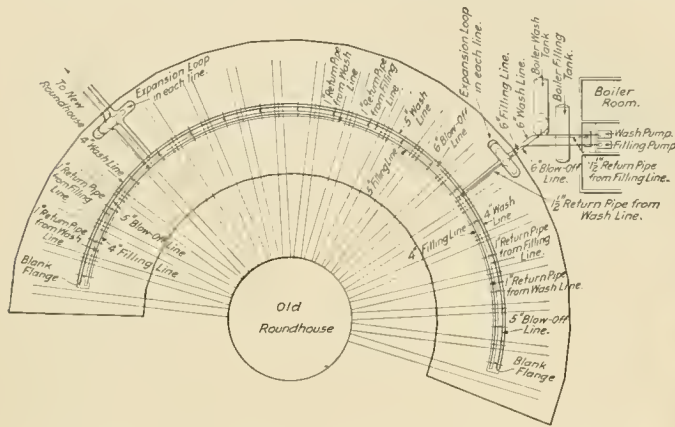
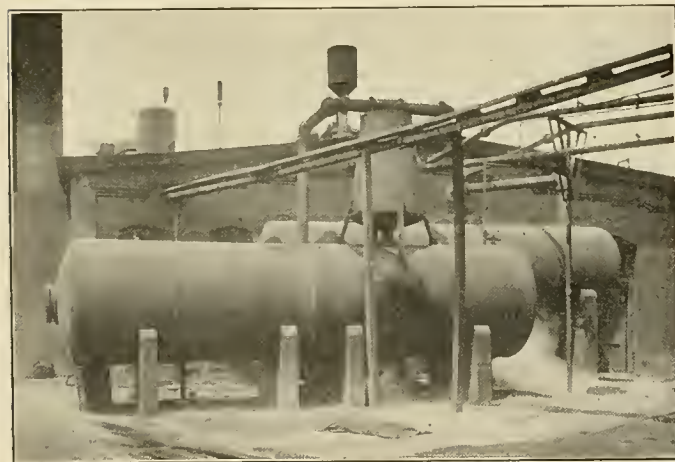

Diagram of Piping Between Boiler Room and Roundhouses

The supply of fresh water to the filling tank is controlled by a float valve in the feed water heater.

The shop boiler blow off is connected to the blow off tank and the shop boilers are washed with hot water furnished from the washing tank. Suitable drains and blow offs are provided, however, to isolate the boiler washing system from the power house piping system when so desired.

The function of the water seal manhole is to give a free outlet for all drips and overflows while maintaining a suffi-



Blow-Off, Washing and Filling Tanks

cient pressure on the exhaust steam to make it available for heating buildings. This feature is, however, not in use at present.

The washing and filling pumps can be used to pump from the supply main directly into the hydrant line if it is desired to increase the water pressure in case of fire. Only the suction connections for this purpose are shown in the diagram.

It has been found that the locomotives practically furnish sufficient hot water for boiler washing purposes, and that sufficient steam is liberated to heat all the fresh water needed for filling boilers. Connection to the engine room exhaust mains has been made, however, in order to take advantage

of the equalizing action of the constant steam supply and to overcome any difficulties which might arise through an unusual sequence of the operations of blowing, washing and filling.

The system has sufficient capacity to permit nine operations to be carried on simultaneously. Three engines can be washed, three engines can be filled and three engines can be blown down at the same time. Liberal pipe sizes have been used in all cases, which enables all of the operations to be carried on with despatch. The time required to blow down a consolidation engine, with a boiler capacity of 2,115 gal., and 60 lb. steam pressure, was found to be 35 minutes. This time could be reduced practically one-half by using the second blow off. The time required to fill this boiler to one gage was 12 minutes, the temperature dropping from 210 deg. Fahrenheit at the start to 206 deg. at the finish. The boiler of a Mallet type engine having a capacity of 5,025 gal. was blown down from one gage of water at 125 lb. steam pressure in 55 minutes. It required 12 minutes to fill this boiler to one gage, at a starting temperature of 208 deg. and a

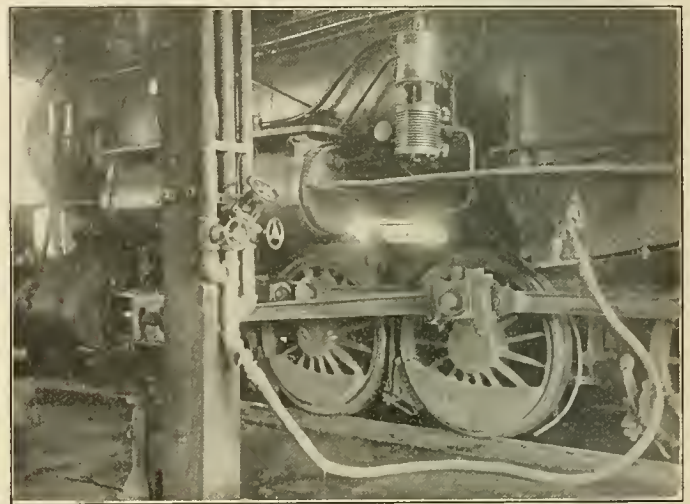

Arrangement of Drop Lines Between Roundhouse Stalls

finishing temperature of 195 deg. Another boiler was being filled at the same time.

With this system blowing down is accomplished with no evidence of steam or noise in the roundhouse, and the cost of boiler washing has been decreased. Some saving has also been effected by using the hot water from this plant for washing the machinery of the locomotives.

This system cost completely installed approximately \$11,000, and the cost of up-keep has been practically nothing since its installation. It was designed and installed by Westinghouse Church Kerr & Company, New York.

POWER OF MACHINERY IN GREAT BRITAIN.—Mr. W. Pares, at a public meeting, lately held at Birmingham, stated in proof of the increase of the powers of production by the improvement of machinery, that in 1792, the machinery in existence was equal to the labor of ten millions of laborers; in 1827, to 200 millions; and in 1833, to 400 millions. In the cotton trade, spindles that used to revolve 50 times in a minute, now revolve in some cases 800 times in a minute. In one mill at Manchester there are 136,000 spindles at work, spinning one million two hundred thousand miles of cotton thread per week. Mr. Owen, of New Lenark, with 2,500 people, daily produces as much cotton yarn as will go round the earth twice and a half. The total machinery in the kingdom is calculated now to be equal to the work of 400 millions, and might be increased to an incalculable extent under proper arrangements.—Extract from the Birmingham Journal in the American Railroad Journal, February 6, 1835.

## OBSERVATIONS ON APPRENTICE SCHOOLS

BY ROBERT W. ROGERS

Apprentice Instructor, Erie Railroad, Port Jervis, N. Y.

An apprentice instructor should have unlimited patience and be enthusiastic about his work. It is this enthusiasm which is instilled into the apprentice that keeps up the fighting spirit of the boys and makes them determined to master their tasks. No boy should be employed who smokes cigarettes or uses intoxicating liquors. A railroad wants men with steady nerves and clear brains, so it begins with the boys. While a thorough knowledge of the trade is necessary for the instructor, yet if he leads the boy to be morally clean, honest, truthful and loyal to his employer, the latter will attain confidence in his own ability and a determination to do right, and will learn to do his work well. The formation of apprentice clubs for healthy amusements is to be commended.

Many railroad officers have given the apprentice school their endorsement and are interested in the development of the work. In many cases, apprentice instructors have made good workmen out of boys whom a foreman would have discharged. Where boys can be secured who have had one or more years in high school, the instructor does not need any special training for instruction in mathematics or even the elements of drawing; but where the boy has had but an elementary school education, an instructor should have a liberal education in order to instruct in the various elements of arithmetic at least, and to explain correctly and clearly the various problems in connection with shop work. There is no doubt that great benefit would result by changing the instructors about from time to time, or even detailing one instructor to lecture on a subject in which he is particularly well versed, as, for instance, tool making, gas engines, or electricity. We each have a natural inclination for some one or two subjects, so one instructor may excel along one line and another along a different line; thus a change would benefit the apprentices in more ways than one.

In giving instruction in electrical work, it is well to keep away from mathematics except for the simplest problems, because the more complex problems of alternating currents require a more thorough knowledge of mathematics than any high school or night school can give.

Much has been written concerning the selection of an ap-

prentice to try the trade out; no one knows how he will like the work until he tries it.

The work of apprentices is often handicapped by the lack of facilities. A separate department containing a lathe, a shaper, a drill and a small planer could at most plants be set aside for the apprentice to work on under the supervision of the instructor. After six months at such work, the apprentice would be ready to go in the shop for work under the various foremen. In shops where no erecting work is done, a small locomotive could be supplied for the apprentices to work on, performing such work as stripping and assembling, checking valve motion, lining shoes and wedges, and guides. This would tend to offset the lack of an erecting shop.

The idea of laying off an apprentice the same as a helper seems rather crude; in fact, it is contrary to the object set forth in hiring a boy to teach him his trade. This is the reason so many boys quit even after serving one year; they are treated, not as wards of the company, but simply as cheap laborers. It is a short-sighted policy for any railroad to treat the prospective machinist, boilermaker or blacksmith in such a manner.

That this is an age of specialists holds true for the apprentice. It is the duty of an instructor to watch his apprentices carefully and discover a boy's natural bent and do all he can to further his work along the lines for which he proves best fitted. The men and the company will gain much by having a few experts, rather than numbers of jacks of all trades.

No apprentice school is complete without a lantern for projecting on a screen illustrations of the various parts or objects under discussion. This lantern should be supplemented by charts on the work in the various shops, as these add to the effectiveness of the lecture and save time in instructing.

## REPAIRING AIR PUMP GOVERNORS

BY J. A. JESSON

The tools for repairing the diaphragm portion of Westinghouse pump governors, which are shown in the engraving, were made from the designs of the author at the South Louisville shops of the Louisville & Nashville.

When the seat of the diaphragm valve becomes worn, to restore it to its original condition it is necessary to enlarge and plug the port hole and make a new seat. Fig. 1 shows the old port drilled and a brass plug B,  $\frac{1}{4}$  in. in diameter and  $\frac{3}{16}$  in.

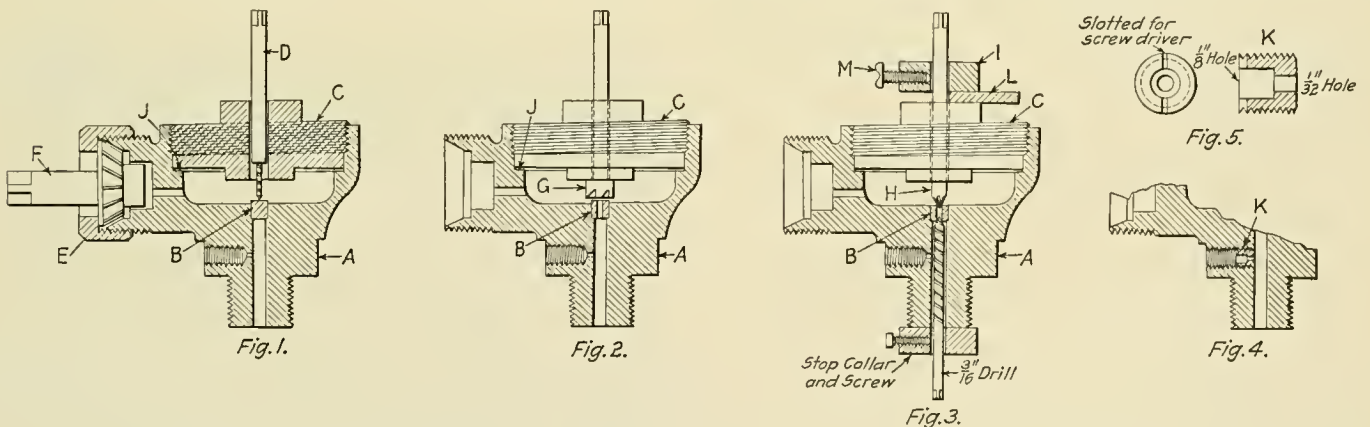

Repairing the Diaphragm Portion of Westinghouse Air Pump Governors

prentice, but no one can tell whether a boy will make good by simply looking at him and making a casual investigation of his educational fitness. A boy should, of course, be made to pass certain requirements, but under the present laws in various states it becomes practically impossible to hire a boy under 16 years of age, and few boys at that age have not had at least some school training. It is advisable to give a boy about six months

long, driven in. The jig C pilots the drill D in drilling a  $\frac{1}{8}$  in. hole through the plug B. Fig. 2 shows a facing reamer G fed by the jig C. The thickness of the reamer body is such that when enough stock is removed from the plug B, the jig will engage the shoulder at J. This operation squares up the seat and leaves it the right height.

Fig. 3 shows the jig in position for operating the valve seat



reamer *H*. The reamer is dropped against the plug *B*, a disc *L*, 0.018 in. thick is placed between the jig *C* and the collar *I*; a set screw *M* tightens the collar *I*, and the disc is then removed. The reamer *H* is then turned until the collar *I* engages the jig *C*; by this means a definite bearing is secured. A 3/16 in. drill, provided with a stop, is run in from the lower end of the diaphragm body, its purpose being to maintain the correct length of 1/8 in. bore for port hole.

Figs. 4 and 5 show the method of renewing the vent port. A short 1/4 in. brass plug *K*, threaded and drilled as shown in Fig. 5, is screwed into the vent port tapping. A center punch is driven into the 1/8 in. hole of the plug *K*, setting it out and securing it from loosening.

In Fig. 1 a beveled reamer *F* is shown in position for truing the union joint bearing. The reamer is fed by the nut *E*.

### TESTING CAR ROOFS FOR LEAKAGE

The device shown in the engraving is in use at the Topeka shops of the Atchison, Topeka & Santa Fe for testing the roofs of box cars for leakage. It is arranged in the form of a stand pipe located at the side of the track, or between two tracks, and has a spray delivery which can be swung over the center line of the track. When not in use it can be swung out of the way.

The construction is clearly shown in the illustration. A flanged cast iron pipe 6 ft. long and 4 1/4 in. inside diameter is bolted to the top flange of a cast iron elbow, the side flange of which is connected to the water main. The lower flange of

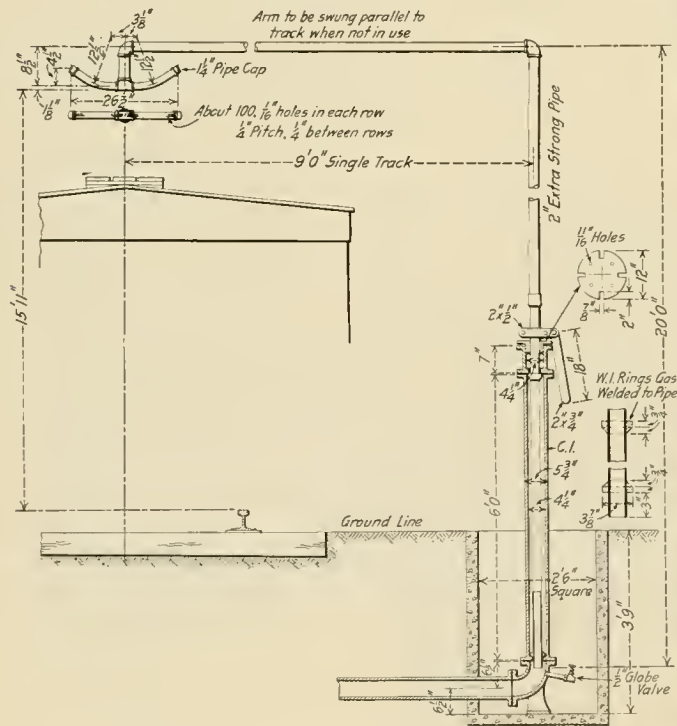

Swinging Crane for Testing Car Roofs for Leaks

this pipe extends inside the bore to a diameter of 2 1/2 in., thus forming a step bearing for the 2 in. extra strong pipe of which the swinging member is composed. A gland casting is bolted to the top flange of the 6 ft. pipe, the bottom flange of this casting forming a bearing for the vertical stop collar on the 2 in. pipe.

The nozzle is arranged to deliver a fan shaped spray which will reach practically all points across the roof of the car, the cars to be tested being drawn slowly underneath the crane. The device is being operated on the regular water main pressure, of 100 lb. per sq. in. The cost of installation is small and arrange-

ments have been made to place similar devices at various points on the system where heavy repairs are made to freight cars.

### SPRING RIGGING AND TIRE REPAIRS

BY J. S. WILLIAMS

General Foreman, Chesapeake & Ohio, Charlottesville, Va.

The maintenance of spring rigging and tires on heavy locomotives gives the average roundhouse foreman considerable concern as to the quickest and cheapest method of handling the work, as it is essential that engines be repaired and returned to service as quickly as possible in order that no delay can be traceable to the mechanical department.

The problem of handling such repairs has been solved in a simple and inexpensive manner at Charlottesville, by placing

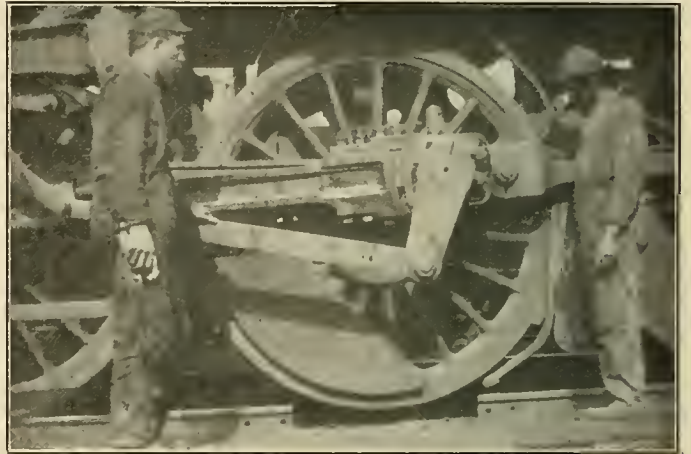

Driving Wheel in Position for Tire Work

two drops in the rails of one of the roundhouse pits. This is accomplished by removing from the pit track 36 in. sections of rail located under the front and back drivers. With the drops so located, any pair of wheels under a locomotive can be placed over one or the other. The short sections of rail, when not in use, are held in place by a 1 1/4 in. by 3 in. strap, bolted with 1 in. bolts.

All spring rigging and tire work is done on this pit. When

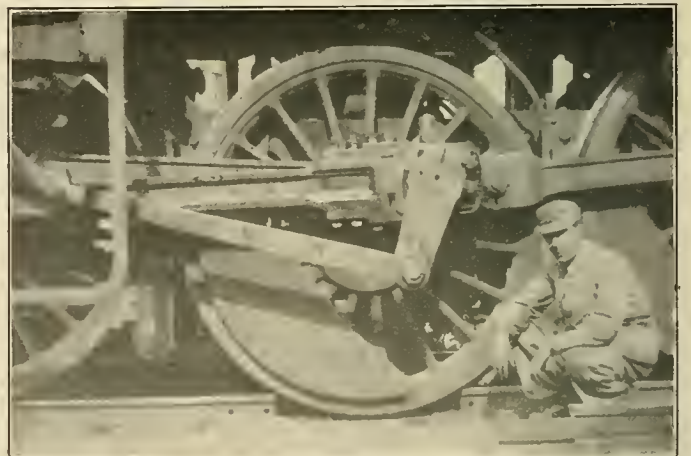

Driving Wheel in Position for Applying a New Spring

it is necessary to renew a driving spring, the wheel is first run up on a wedge, and blocking placed under the spring rigging in order to relieve the load on the spring which is to be removed. After this the wheel is run off the wedge, the 36 in. section of rail is removed and the engine is moved so the wheel will drop

into this space, relieving the spring entirely of its load, so that it can be removed and a new one applied without the use of bars or spring pullers.

When it is necessary to change, tighten or re-set a driving or trailing tire, blocking is first placed between the bottom brace of the frame and the journal box. This holds the wheel in its original position, while the short section of rail is removed and the engine is moved so the wheel will come directly over this space, leaving the entire circumference free.

With the adoption of this method of handling this class of repairs, we have entirely eliminated the practice of jacking engines, at the same time reducing the expense for labor 50 per cent, and returning locomotives to service considerably quicker than when the old method was followed.

## RECLAIMING CAST STEEL DRIVING BOXES

BY H. C. SPICER

Gang Foreman, Atlantic Coast Line, Waycross, Ga.

It has been found practicable in the Atlantic Coast Line shops at Waycross, Ga., to refit cast steel driving boxes after they have become badly worn, so that they are again available for considerable service.

If the slots shown at 1, which form the seat for the spring saddle, are worn they are milled out on a key seating machine and a spring steel plate fitted in to bring them back to proper size. The hub face of the box is faced and dovetailed  $\frac{1}{4}$  in. to  $\frac{5}{16}$  in. deep at 2, and the crown and hub brasses are poured in one operation. This makes an economical way of building up the hub side of the box when it is worn and saves consider-

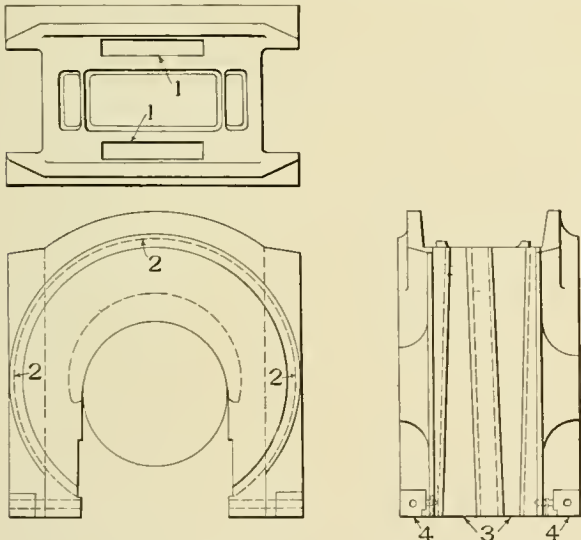

Operations in the Reclaiming of Cast Steel Driving Boxes

able time and labor in the turning and fitting of the crown brass. It is believed that this operation could be well adapted to new boxes as well as old ones. Two wedge shaped slots are dovetailed on the shoe and wedge fits as shown at 3 and brass poured in to form a liner. The boxes can thus be brought up to the original size for the shoe and wedge fit. If the cellar bolt holes are broken out at the corners at 4, the corners of the box are planed off and plugs fitted to them and fastened in by  $\frac{1}{4}$  in. dowels.

FOOLISH QUESTION No. ——"What elevation per mile, may be considered, with locomotive power, equivalent to an additional mile on a level road?" Will some of our railroad friends, who have more leisure than we, please answer the above query?—Editor.—From the American Railroad Journal, March 7, 1835.

## CROWN SHEET EXPANSION STAYS

BY N. H. AHSIULH

The subject of crown sheet stays adjacent to tube sheet flanges, has been given much consideration in the past few years in an endeavor to correct existing defects in locomotive fireboxes. As a result of these defects, the renewal and patching of tube sheets form very considerable items of expense in firebox maintenance. Having had extensive experience with nearly every type of crown sheet stay, the writer will endeavor to show wherein lie the weaknesses of each type, and suggest a method of staying to eliminate tube sheet failures.

First, considering the standard T bar construction as shown in Fig. 1, it is always found when necessary to remove T bars of this construction after a period of service of from four to eight years, that the bolts, bars and sling connections are all in one solid mass. Scale has formed around the slings and sup-

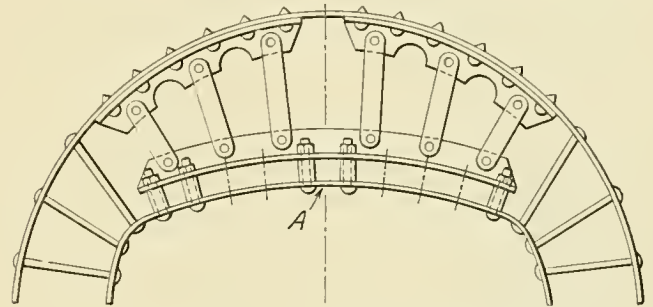

Fig. 1—Standard Crown Bars in Radial Stay Boilers

porting bolts and nuts, making it very difficult to remove them from the boiler. This fact of scale formation will prove the absence of flexibility, or any possible adjustment of this construction to the various movements of the crown sheet due to tube sheet expansion and contraction. The deterioration of the top flanges of tube sheets is caused by the rigidity of T bar construction, which confines the resultant stresses set up by the expansion of the tube sheet, to the short space between the top tube holes and the center line of the first transverse row of crown supporting bolts, as at C, Fig. 2. Where these stresses are distributed over a wider area of the crown sheet the deterioration of the tube sheet knuckles is not evident.

At the highest point on the top tube sheet flange, which lies

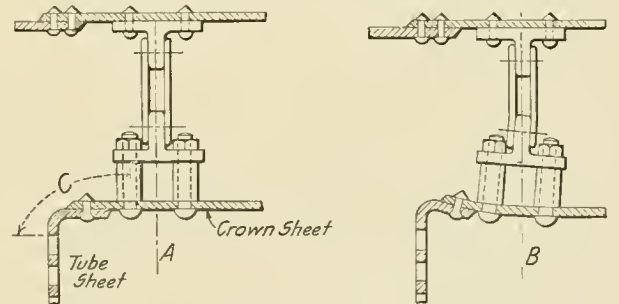

Fig. 2—Effect of Rigid T Bar Construction

on the vertical center line, is where the first distortion due to expansion takes place, extending toward each side as distortion progresses. This can be proven in a Belpaire boiler, having expansion crown stays as in Fig. 3, where the distortion of the tube sheet is always greatest in the center, gradually decreasing to nothing at the sides. Also by holding a short straight edge against the vertical web of the T bar at the center, a very decided deflection of the bar toward the backhead will be noted, especially where the top tube sheet flange is badly distorted. This is shown at B in Fig. 2.

By rigidly bracing a crown T bar to and equidistant from the



crown sheet throughout its entire length, we secure the crown sheet so that, theoretically, no movement can take place at the center of the sheet unless a corresponding movement takes place under the entire length of the T bar. As the first compressive strains are communicated to the crown sheet in the center, the sheet under the entire length of the T bar receives corresponding strains much sooner than it would if not rigidly braced to the T bar. The foregoing statements will show that the flexibility of movement sought for is defeated by this construction.

Another very serious defect arising from this method of staying is the sagging or pocketing of crown sheets under the ends of T bars, as shown at *B* and *B'* in Fig. 4. There are three causes for this condition:

1. The application of thimbles or nuts between the crown sheet and the under side of the T bars;
2. The backward twist of the center of the T bar as previously

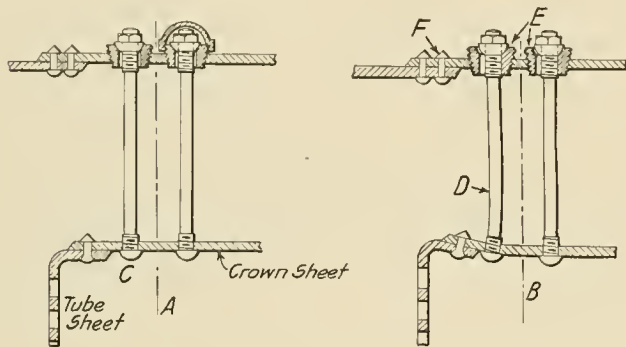

Fig. 3—Expansion Crown Stays in a Belpaire Boiler

mentioned, which causes a forward and downward thrust of the ends of the T bar;

3. The fact that the T bar is an independent factor and its expansion and contraction in length are not controlled by, and have no connection with the relative expansion and contraction of the outside and inside firebox sheets.

The outside and inside firebox sheets being rigidly stayed, do not relatively change position due to expansion and contraction. For the same reason the T bar does not change position vertically. Horizontally it does expand and increase in length as there is nothing to prevent it from so doing. The sling stays *F* and *G* in Fig. 4, being radially applied, do not retard this movement. The T bar being curved, the expansion will follow the line of curvature and the resultant lengthening of the T bar will bring it closer to the sheet at the ends than at the center,

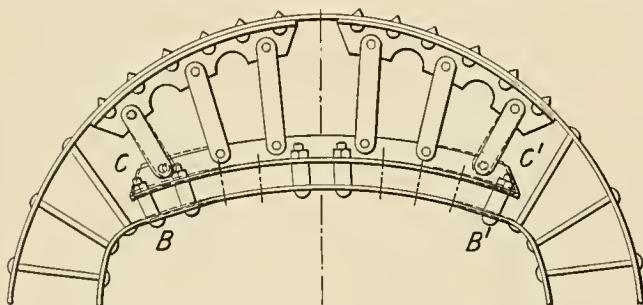

Fig. 4—Standard Crown Bars After a Period of Service

as at *C* and *C'*, Fig. 4. With each repeated firing of the boiler the bar lengthens and comes closer to the sheet. If there are thimbles around the end crown bolts, the sheet is forced down and bulges toward the fire.

In proof of these statements, we find when applying to a new firebox the exact counterpart of the old one when it was new, a T bar removed from an old firebox, that the end holes do not line up with the holes in the firebox, and also that the radius of the T bar has changed. The T bar must be heated and the ends

raised to make it conform to the curve of the new crown sheet. This situation clearly shows that the ends of the bar have come down; also that the bar has become longer while in service.

To eliminate the sagging of crown sheets, the writer has practiced the slotting of three end holes in each row of holes,  $1\frac{1}{2}$  in. long for 1 in. bolts, then applying these three end bolts without thimbles between the T bar and crown sheet, as shown in Fig. 5.

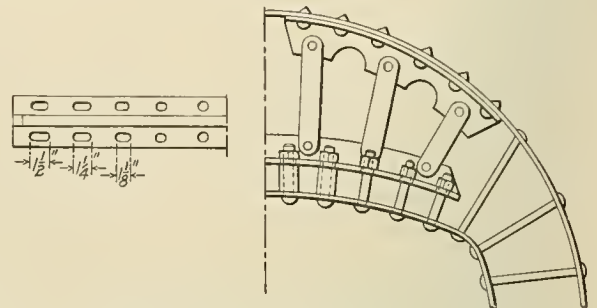

Fig. 5—Eliminating Crown Sheet Sagging

Crown sheets with bars applied in this manner run four years without sagging or bulging of sheets, whereas bars applied with thimbles around all bolts will cause sheets to sag from  $\frac{1}{2}$  in. to  $\frac{3}{4}$  in. within three years' service in the same districts.

In making comparisons of the two methods, a peculiar condition presents itself. Whereas a crown sheet will sag in engines with thimbles around the end bolts from  $\frac{1}{2}$  in. to  $\frac{3}{4}$  in. in three years' service, in engines having slotted holes in the bars and no thimbles around the end bolts, it is barely possible to insert a knife blade between the crown bolt nut and the face of the T bar, and the sheet has not sagged.

While this practice has eliminated the sagging of crown sheets, it has had no noticeable effect on the deterioration of flue sheet knuckles, the same defects existing with either method.

Next let us consider the eyebolts shown in Fig. 6. Eyebolts in outside and inside firebox sheets, connected by sling stays,

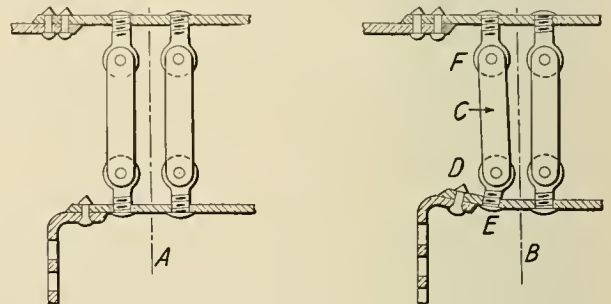

Fig. 6—Illustrating the Action of the Eyebolts

have been used quite extensively in an endeavor to eliminate defects at the top tube sheet flange. When this arrangement is properly applied with all parts in tension, which is not always the case, we have, after a time, conditions as shown at *B*, Fig. 6. The edge of the crown sheet, curling back as a result of the upward movement of the tube sheet, will cause the top of the bottom eyebolt to move in a backward direction. When this movement first begins the supporting sling *C*, Fig. 6 becomes loose, but as distortion of the sheet progresses it gradually becomes tighter, the line from *E* to *F* becoming the hypotenuse of the triangle *EDF*, of which the slingstay and bottom eyebolt form the other two sides. The rigidity thus produced prevents flexibility of movement, and produces the same defects in the top tube sheet flange knuckles that are found with the T bar construction.

Fig. 3 illustrates the application of sleeves in the outside firebox sheet, through which the crown bolts are applied. The bolts have nuts and washers on the top end, and button heads at the crown sheet end. This arrangement has been in use in the Bel-

paire boilers of an Eastern road for upward of 15 years, and with the exception of the style of nut and washer, is exactly the same arrangement now being extensively installed in radial stayed boilers.

As tube sheet expansion progresses, with this method of staying the crown sheet is curled up as shown at *B* in Fig. 3. The crown bolts in the first transverse row nearest the vertical center line as at *C*, Fig. 3, are forced backward causing the back end of the top of bolt to ride hard against the sleeve as at *E*. In these particular engines the sleeves were made of brass, and the bolts sunk into the sleeves to the depth of the threads. Further travel of the tube sheet upward caused the bolts to bend as at *D*.

This arrangement allows stresses set up by tube sheet expansion to spread over a larger area than any type so far dis-

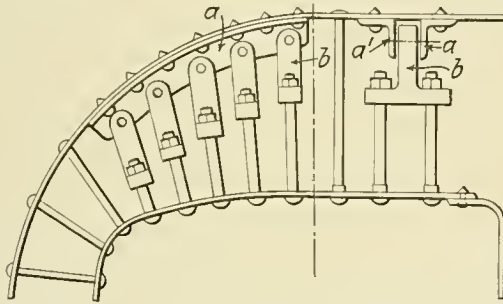

Fig 7—A Type of Construction Used in Radial Stay Boilers

cussed. As a result of wider distribution of stresses, there was no deterioration of the top tube sheet knuckles evident; also there was never any sagging of crown sheets. The writer has repaired hundreds of boilers containing this type of crown stay, in many of which the distortion was so great that the tube holes were on a line with the rivet heads in the flanges, making it impossible to expand the tubes in a proper manner, yet the top flange knuckles of these tube sheets were in perfect condition, no cracks or defects of any kind, outside of the distortion in shape, ever having been noticed.

A very serious drawback to this construction is the fact that the vibratory strains of the tube sheet expansion are communicated to the outside sheet, which causes cracks to start through

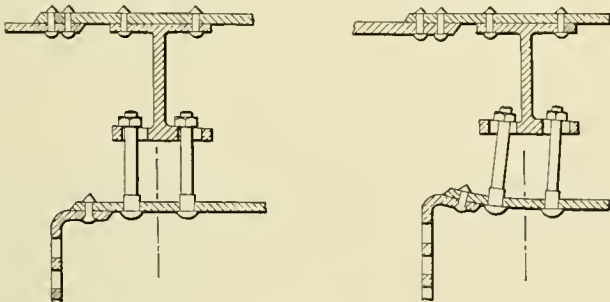

Fig. 8—Recommended Construction

the center of the rivet line shown at *F*, Fig. 4. These cracks always develop at the vertical center line first, and travel toward each side as distortion progresses. This is caused by the threads on the crown bolts sinking into the brass sleeves and communicating the vibration of the tube sheet to the roof sheet. In from three to five years' service it is always necessary to apply patches to repair these cracked sheets.

Another defect of this construction is the fact that the greater the deflection of the bolts backward, the less tension there is on the bolts when the boiler is under pressure. These same defects will develop in an arrangement now being extensively applied to radial stayed boilers. In this case iron sleeves are used instead of brass, and ball joint nuts are used in the sleeves instead of flat nuts and ball joint washers. There is no doubt that tube sheet deterioration will be very materially reduced, and on ac-

count of outside sheets being circular there will be no cracks in these sheets. The fact remains, however, that after the sheets have become distorted, the bolts will never be in tension when the boiler is under pressure.

A construction used by the railway previously referred to, in their radial type boilers, is shown in Fig. 7. Angle irons *A* and *A'* are riveted to the outside sheets, and crowfeet *b* hung from them, the crown bolts being secured to the crowfeet as shown. The longest bolts are adjacent to the vertical center line, where the strains resulting from distortion of the tube sheet are taken care of by the ability of the crowfeet to move slightly, and the bolts to bend slightly and ride hard against the back of the holes in the crowfeet. This construction eliminates cracked tube sheets and there are no sagged crown sheets, but the same absence of tension in the bolts when the boiler is under pressure is in evidence.

The foregoing illustrates practically every construction extensively used to stay the crown sheet at the tube sheet flanges. There are serious drawbacks to every one, the most serious being the absence of tension on the bolts after distortion has taken place. This may be an important factor, contributing to the dropping of crown sheets due to low water. Bolts or braces which are not always in tension should never be applied to crown sheets.

The application of more than two transverse rows of any kind of bolts to provide flexibility of sheets is an error. It will be plain after a study of the sketches in this article, that the crown sheet could not move vertically at the third or fourth transverse rows of bolts, without stretching at the side roll.

Fig. 8 represents the writer's idea of a construction which will eliminate defects now existing. It consists of an I bar, cast with slotted holes, to allow the crown bolts to move as shown. By this construction the advantages of other arrangements will be retained, and the bolts will also be in tension all the time while the boiler is under pressure.

In conclusion, the writer believes that the entire subject will become clearer in the minds of those interested whenever the idea becomes more prevalent that, while the tube sheet does move upward, the bolts in the crown sheet do not. The crown sheet curls upward and backward, and the top end of any bolt tapped at a right angle through the crown sheet must move at a right angle to the movement of the crown sheet, or backward and downward. All types of crown staying used are based on the theory that the top ends of crown bolts move upward as a result of tube sheet expansion. This is entirely wrong and can be readily proved so by the use of diagrams.

## CHECK NUT FOR HOSE CONNECTIONS

BY CHAS. MARKEL

In order to prevent the hose nuts between the engine and tender becoming loose and working off, allowing the water to be lost from the tender before the engine crew discovers it, the de-

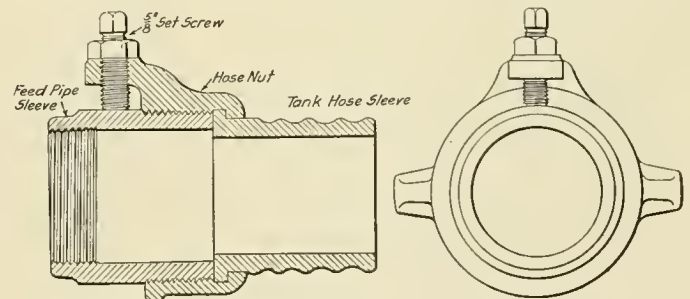

Check Nut for Tank Feed Hose Connections

vice shown in the illustration was developed by the author. A projection or lug is cast on the hose nut and is threaded for a set



screw; after the hose nut is properly tightened, the steel cupped set screw is set tight against the feed pipe sleeve and the jam nut against the set screw, thus preventing the hose from becoming separated.

### DEVICE FOR BENDING MEAT HOOKS

BY J. LEE

The machine whose construction and operation are shown in the accompanying engravings, was designed to reduce the cost of manufacturing meat hooks used in refrigerator cars. It is air operated and forms both ends of the hook in one operation,

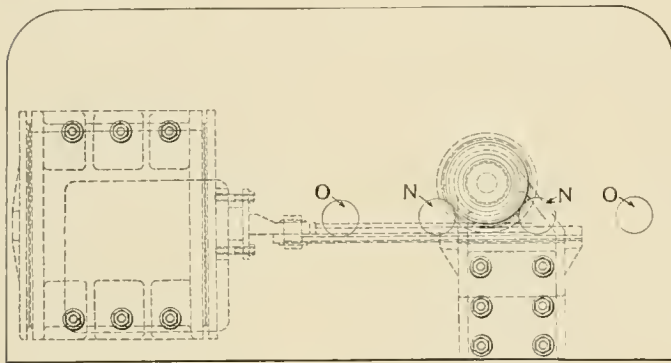
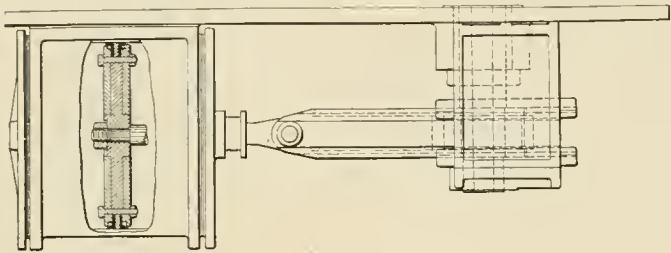

Table and Cylinder of Device for Bending Meat Hooks

the metal being worked cold. Before it was installed the hooks were bent hot by hand, each end being worked separately over a die.

The machine consists of a table, to the under side of which are

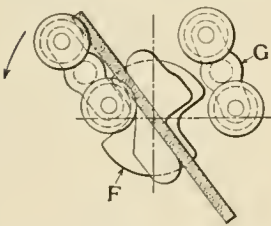

Fig. 1 - Beginning of Stroke. Start of Bend on 1st. End.

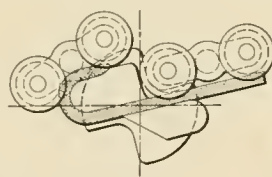

Fig. 3. Start of Bend on 2nd. End.

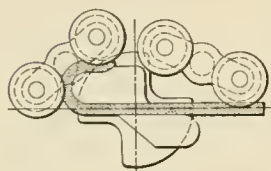

Fig. 2. Finish of Bend on 1st. End.

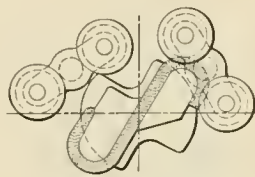

Fig 4 - End of Stroke. Hook Completed

Operation of Die and Rollers

secured an air cylinder and a bearing for the operating spindle, which extends through to the top of the table. A rack working in a guide secured to the under side of the table transmits motion from the piston to a pinion secured to the lower end of the

operating spindle. Die *F* shown in Fig. 1 is keyed to the upper end of the operating spindle.

Hooks of two sizes are made, requiring different size dies. For the smaller size, roller brackets *GG*, Fig. 1, are placed in bosses *NN* shown on the engraving of the table and cylinder. For the larger size they are placed in bosses *OO*.

Figs. 1, 2, 3 and 4 show the operation of the rollers in bending the stock as the die is turned through its operating angle of about 160 deg. In using the machine, stock in large quantities is cut to length on a bolt cutter and taken by a man to a small steam hammer where the ends are pointed. The pieces are then taken by the machine operator and bent cold, ready for tinning. After passing through the tin bath the hooks are ready for shipment. The average output is 1,200 hooks per day.

### PORTABLE COMBINATION TEST RACK

BY F. W. BENTLEY, JR.

Machinist, Butler Shops, Chicago & North Western, Milwaukee, Wis.

The increased number of operating parts used in connection with the E-T air brake equipment generally make the construction of a complete test rack somewhat difficult. The ac-

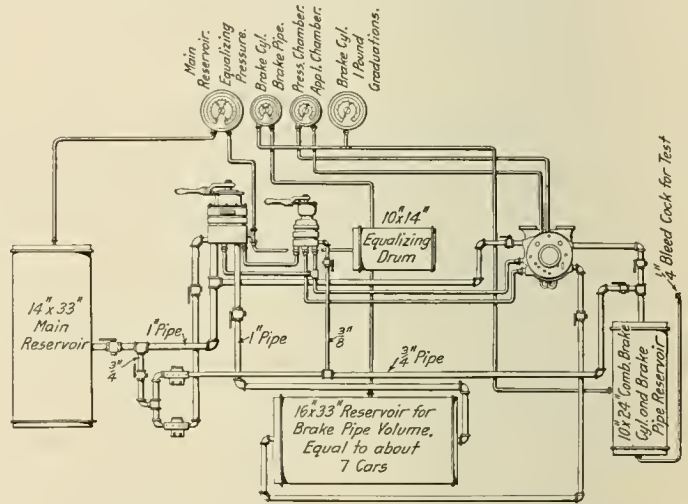

Arrangement of Details of Portable Combination Test Rack

companying illustrations show a combination test rack with cut-out cocks so located in connection with rigidly attached reservoirs, that all parts of the locomotive equipment may be placed on it and tested either collectively or separately.

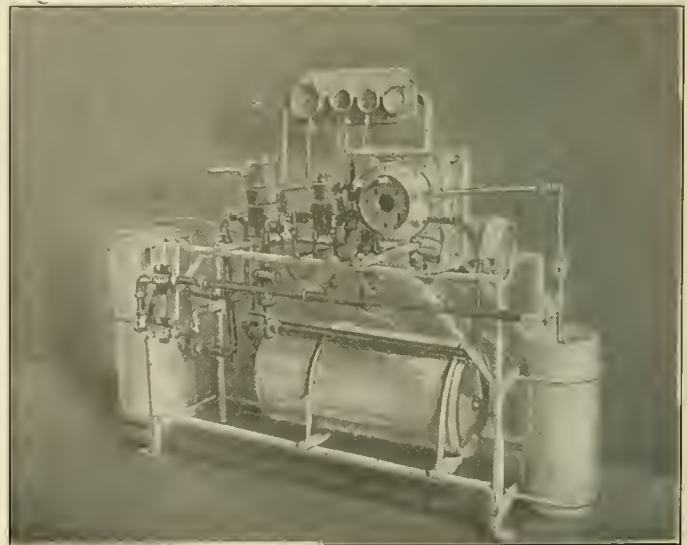

Portable Combination Test Rack

The combination reservoir, so termed in the piping diagram, can be used as a brake cylinder in connection with the examination of the distributing valve, or may be utilized as a small train line volume in the examination of a feed or reducing valve, independent of the rest of the apparatus. The bleed pipe from the bottom of the combination reservoir is used for determining the sensitiveness of the feed valves in an independent test, and for ascertaining in the distributing valve test, the sensitiveness of the application piston in building up leakage.

The whole device is so arranged and built that it can be located anywhere about the shop, as it need only to be lifted clear of the floor to move it. The gage board is equipped with two extra gages, one brake cylinder or combination reservoir gage graduated in pounds, and one E-T No. 2 gage with connections direct to the application and pressure chambers in the combination drum. By this means, the independent test of a feed valve can be accurately made by the brake cylinder gage, and the condition of the graduating valve or the slide valve of the equalizing piston readily told by the action of the hands on the second No. 2 gage.

### CHUCK FOR ECCENTRICS

BY C. L. DICKERT

Assistant Master Mechaic, Central of Georgia, Macon, Ga.

A chuck for boring and turning eccentrics on a boring mill with one chucking is shown in the accompanying photograph and drawing. The chuck is simple in design, and is easily ap-

plied to the machine. The eccentrics are chucked by tightening two nuts which clamp them sufficiently to take heavy cuts. The chuck is so designed that it will take as many different sizes of eccentrics as may be desired by simply changing four grip

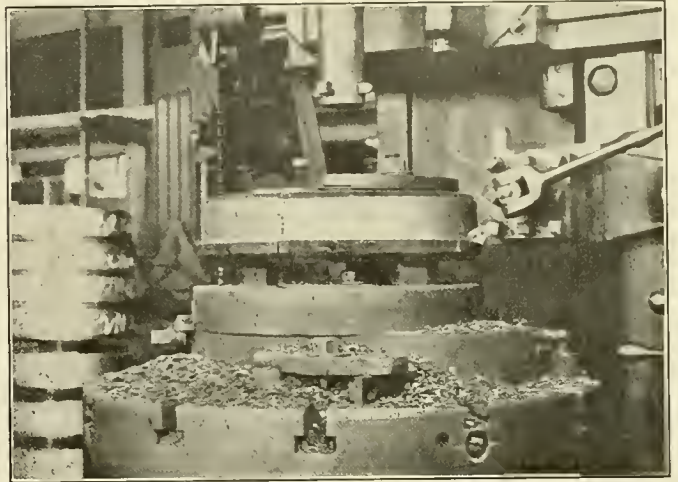

Eccentric Chuck Attached to a Boring Mill

blocks and two studs from one hole to another; it is also made adjustable for any throw of eccentric.

Either the boring or the turning operation can be performed

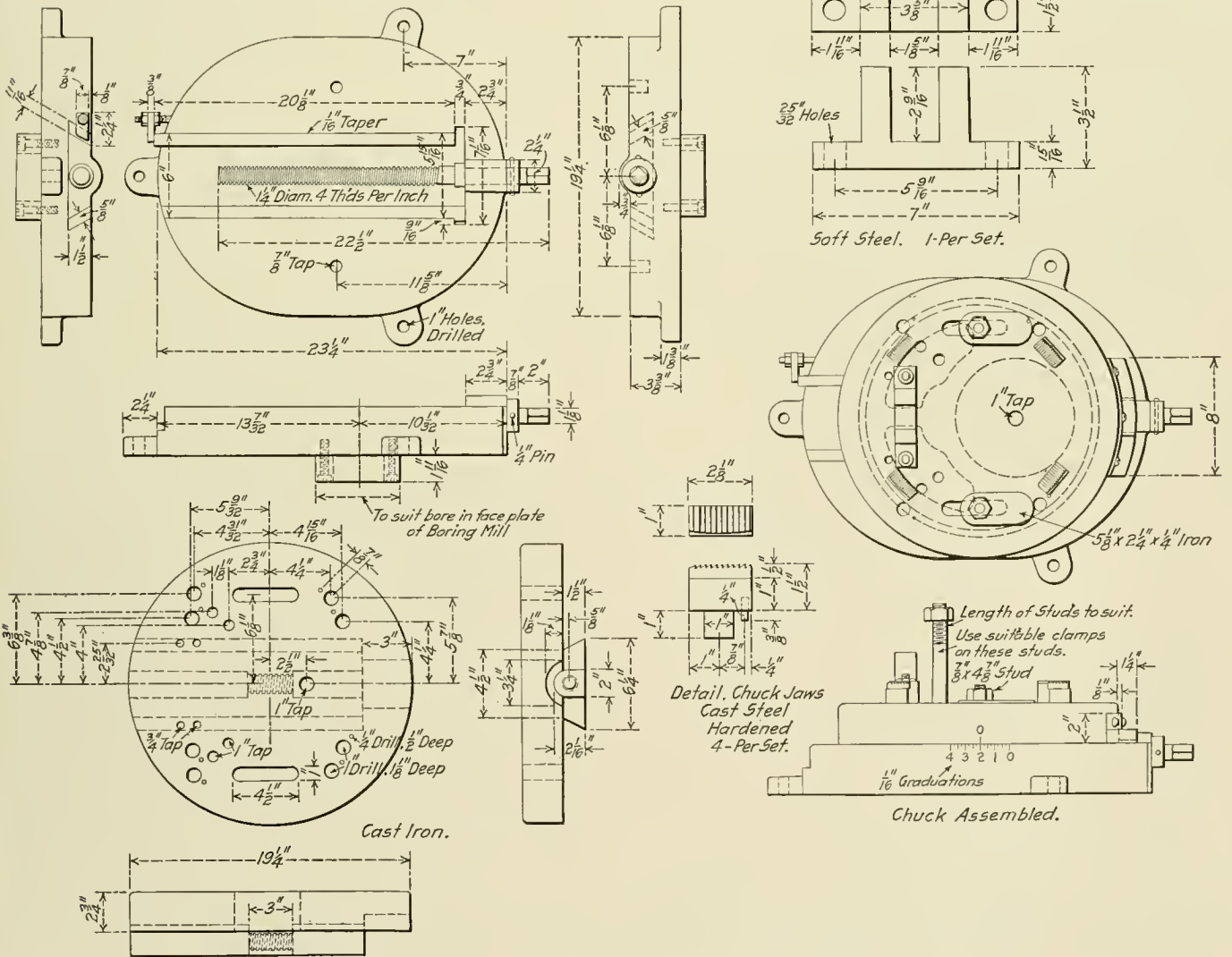

Details of Chuck Used on the Central of Georgia for Boring and Turning Eccentrics on a Boring Mill



first; no laying off of the eccentric for throw is required. Whichever operation is performed first, the chuck is shifted to obtain the desired throw by loosening two nuts and turning the screw. The driver is fastened on the center line of the chuck, and is made in a U shape to fit over the rib in the eccentric; this arrangement acts as a centering device, bringing all the eccentrics to the same center. The four saw-tooth grips, which are made of steel and hardened, are 1½ in. high to allow clearance for tools. The dotted lines on the drawing show the position of the eccentric on the chuck with the clamps omitted.

### EMERY WHEEL STAND

BY PAUL R. DUFFEY

The engraving shows the general arrangement and details of an emery wheel stand for general shop use. This stand will give a great deal of service before it is necessary to renew any parts. A special feature is the means employed to eliminate lost motion from the bearings. This will be seen in the arrangement of the shaft bearing bushing. The outside and inside nuts on the bushing keep it tight, and in order to adjust it so that lost motion may be taken up it is only necessary to loosen the outside nut and tighten the inner one. The ⅛ in. wood strip should be a loose fit to allow for closing slightly without its being necessary to

### CLIPS FOR HOLDING BRAKE CYLINDER HEAD GASKETS

BY F. W. BENTLEY, JR.,

Machinist, Butler Shops, Chicago & North Western, Milwaukee, Wis.

Brake cylinder head gaskets are the cause of much annoyance in roundhouse work. The light, narrow gaskets give the most trouble, particularly if they are being applied with the head, to

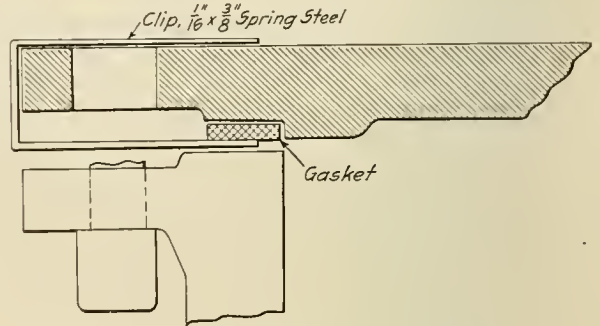

Clip for Holding Gaskets in Position

cylinders which are placed in a horizontal position and close to the cab bracket sheets, with only 5 or 6 in. of working space

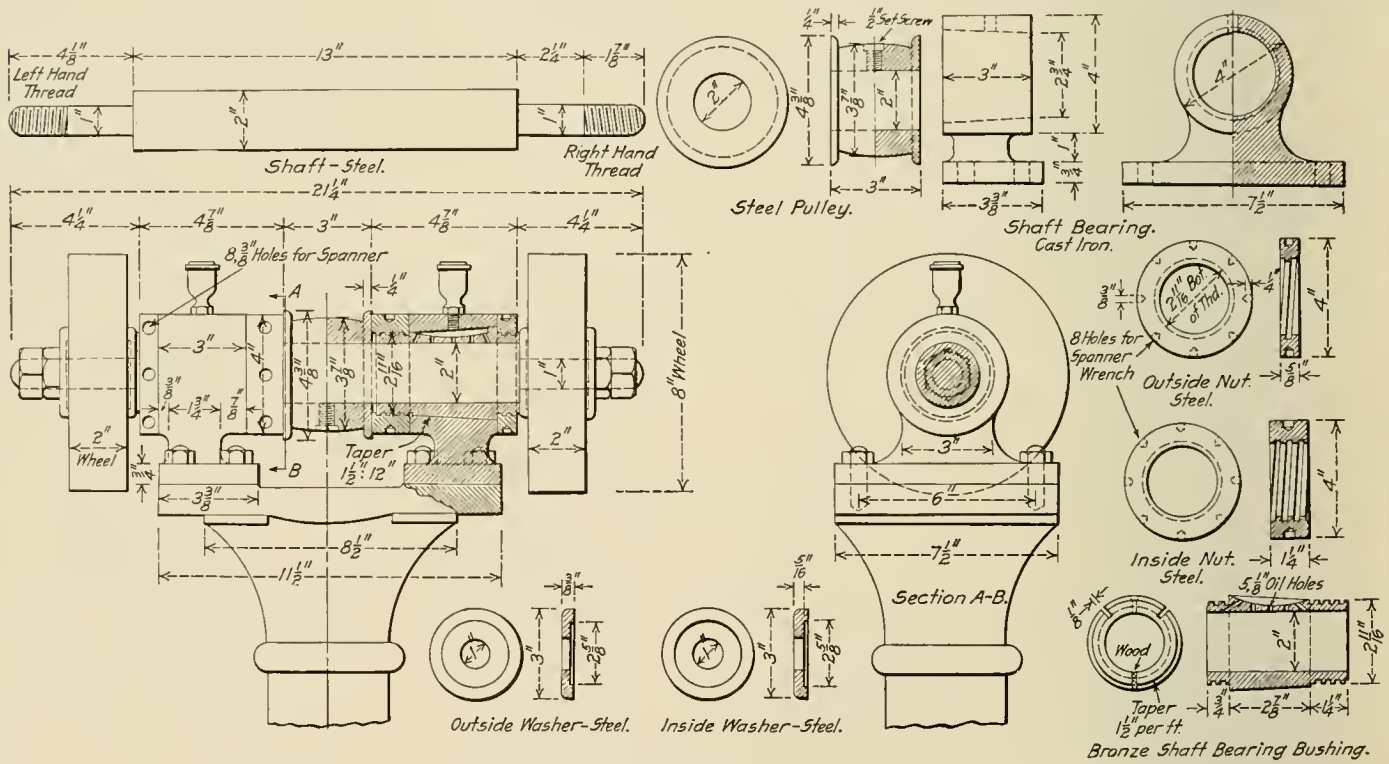

Arrangement and Details of Shop Emery Wheel Stand

remove it and replace it with a thinner strip. This type of stand has been in use for some time in several shops and has proved to be much more successful than many higher priced machines.

TUNNEL UNDER THE DANUBE.—A tunnel under the Danube is under consideration by the Roumanian government to form a connection with its newly acquired territory. A bridge was first considered, but as no protected site was to be found, military precautions forced the abandonment of the project. The proposed tunnel will have heavily fortified terminals.—*The Engineer.*

available for putting the head in place. A coating of thick white lead will in some cases keep the gasket on the joint face of the head while putting it in place, but as all gaskets are not exactly of the same diameter, due to the nature of the rubber, many of them cannot be held in place by this means.

The use of clips, as shown by the accompanying illustration, prevents trouble from the slipping of the gasket, no matter how cramped and inconvenient the working quarters may be. Two or three of these clips hold the gasket securely, and after the head has been secured by drawing up one or two of the head bolts they can be readily pulled out. A number of the clips can be carried in the top of a tool box by means of a piece of tin.

# NEW DEVICES

## GRINDING WHEEL STAND

A floor type grinding wheel stand completely equipped with protection and dust hoods has recently been brought out by the Norton Company, Worcester, Mass. The new design is an outgrowth of the experience of this company in the use of grinding wheels on the many types of floor stands now on the market.

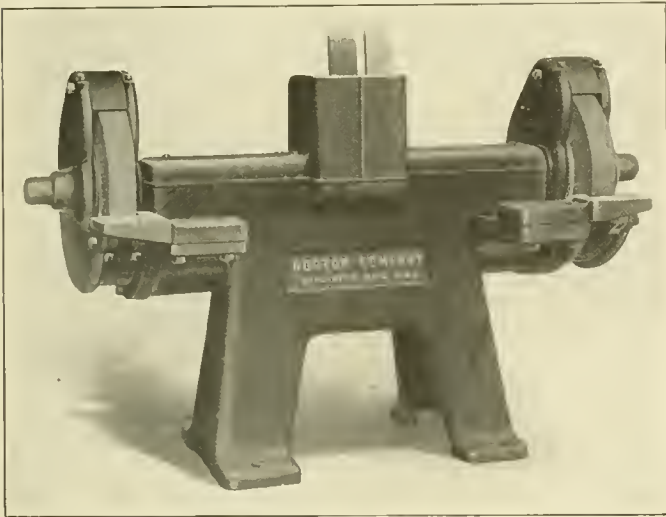

Grinding Wheel Stand with Long Overhang Bearings

While it is not a radical departure from other machines now in common use, care has been taken to provide rigidity of construction, safety, convenience of operation and durability of wearing parts.

The weight and rigidity of the stand permit of a small founda-

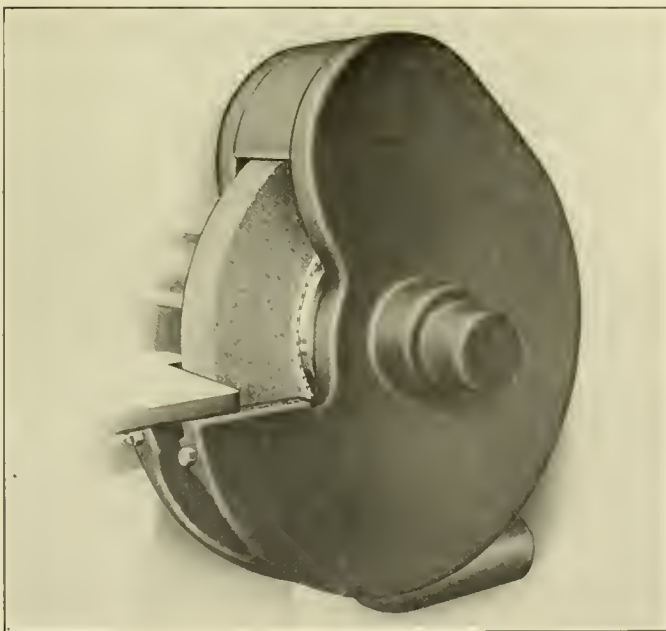

Protection Hood Covering the End of Grinding Wheel Spindle

tion space and a long overhang of the bearing bed. This feature allows ample foot room for the operator. Each bearing is divided into two parts and the large bearing surfaces help to

insure long life. The diameter of the spindle in the bearing is made 1/16 in. oversize, allowing sufficient stock for regrinding when necessary. The portion of the spindle outside the bearings is made sufficiently long to take taper wheels, which have the same width of face as the maximum width of straight wheels. End play on the spindle is easily taken up. The inside flanges are fitted loose on the spindle and driven by a key, making their removal a simple matter. Taper flanges of any make having holes of the right size may be used by cutting a spline in the hole to fit the square key in the spindle.

Oiling is accomplished by the splash system. The oil reservoir, under and between the two parts of the bearing, holds a supply of oil sufficient for several months. All lubricant can be easily and quickly removed, and the reservoir is readily accessible for cleaning. Dust proof covers protect the bearings and an oil guard inside the bearing chamber prevents oil from working out through the joints of the bearing bed and the bearing cover.

The underside of the overhanging bearing bed is provided with

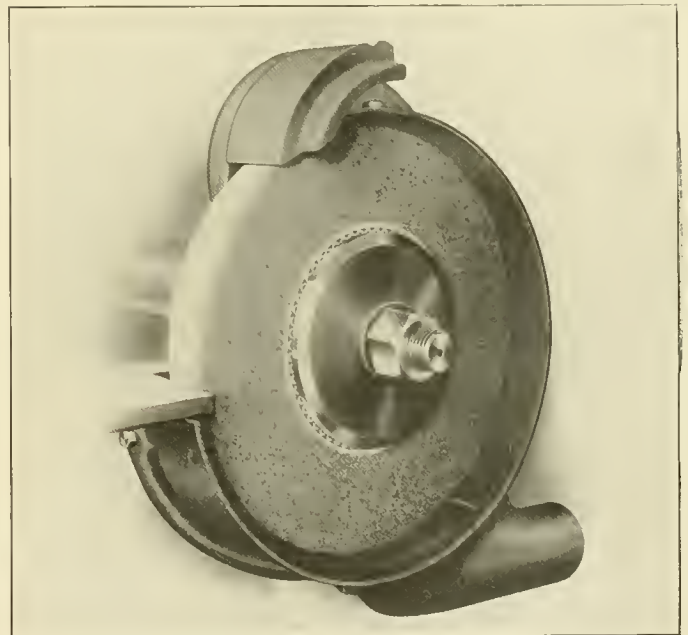

Protection Hood Bracket with Dust Exhaust Connection

a machined seat and tee slots. Work rest brackets, protection hoods and surface grinding attachments are secured by bolts placed in these tee slots, and may be attached or removed very quickly. All attachments are independent and interchangeable. Whenever it is desired to grind large work that requires the removal of the work rest, the work rest bracket can also be removed. This permits the use of a wheel of minimum diameter without interference in grinding large pieces. The top surface of the work rest is chilled, insuring longer life, and is of sufficient size to give adequate support for large and heavy work.

A substantial belt guard, which permits any belt angle from the vertical to 45 deg., extends 2 in. above the top of the maximum size of wheels. This affords protection to the operator, and serves to protect the belt when long pieces are ground on the surface grinding attachment. The protection and dust hood has the double function of providing protection against injury in case of accident to the wheel, and, when connected with a suitable dust removal system, against injury to health from inhala-



tion of dust. The bracket which supports the hood serves also as a dust exhaust pipe.

The closed hood consists essentially of a heavy band of boiler plate and two heads or side plates. The hood surrounds about 5/6 of the wheel, leaving a 60 deg. opening. A heavy steel slide provides adjustment for wheel wear. The slide travels in grooves describing an arc around a center other than the spindle center so that, irrespective of the size of a wheel, 60 deg. of the periphery of the wheel is exposed for grinding purposes and protection is always afforded. This type of hood covers the end of the spindle, thus preventing accidents due to catching clothing in the thread of the spindle. Through the employment of a special lock nut the outer head or side plate is easily removed to permit change of wheels.

### AUSTIN TRAILING TRUCK

A gravity centering trailing truck with journal boxes separate from the frame has been brought out by the Lima Locomotive Corporation, Lima, Ohio, and applied to an order of Pacific type locomotives built for the Great Northern. It is designed to simplify the removal and replacement of journal boxes, and to provide a self-centering radial action of sufficient stiffness to prevent undesirable swinging of the rear end of the locomotive.

As shown in the engravings, this truck has separate journal boxes fitting into steel pedestal castings which form part of the frame. To remove the boxes, it is merely necessary to remove the pedestal tie at the bottom of the jaw. The boxes, wheels and axles can then be dropped in the usual manner. The boxes compare with large sized tender boxes in size and weight, and can be handled in much the same manner. Wheels, axles and

being cast from the same pattern. The radius bar is located approximately on the center line of the axle. This position affords the maximum stiffness to withstand stresses due to horizontal thrust against the axle. It is built up of three parts. The side pieces are of heavy rectangular section, and are securely bolted to a cast steel hinge piece. The rear end of the framing is composed of two side bars secured to the cast steel pedestals, and a cross bar connecting the rear ends of the side bars. On

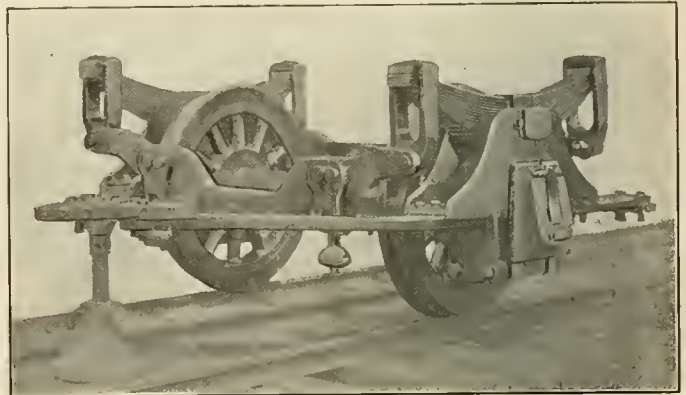

Austin Trailer Truck Completely Assembled

the cross bar is shown a spring centering device, but this is unnecessary and may be omitted.

The suspension system consists of two transverse cradles, one in front and one back of the axle, which are suspended from the springs by stirrup hangers. The rear cradle receives its load from a fulcrum casting secured to the locomotive frames,

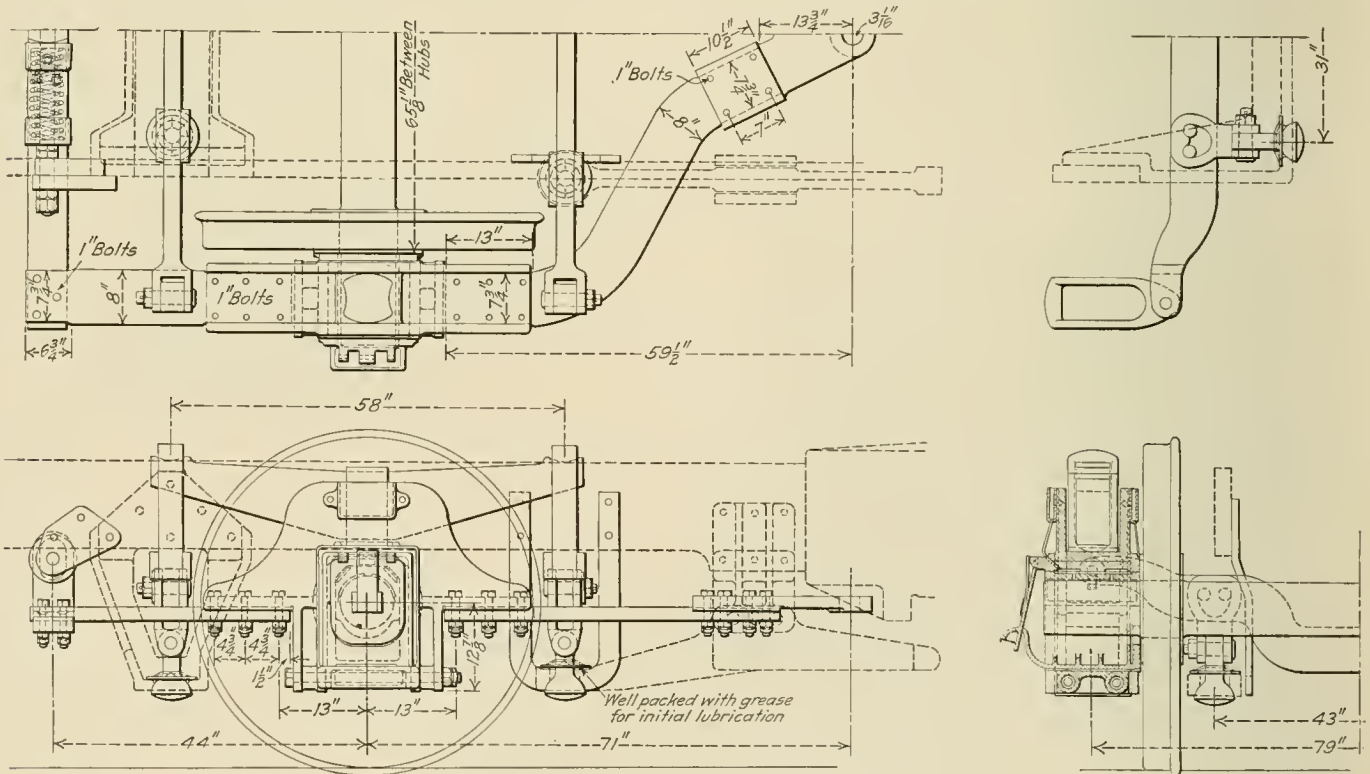

General Arrangement of the Austin Trailing Truck

journal brasses can be made to interchange with those used on other types of trailing trucks.

The pedestal castings are rigidly fastened to the radius bar, and in no way depend upon the pedestal ties for stiffness. The sole function of the latter is the retention of the boxes in the jaws. The pedestal castings are reversible, both right and left

and resting on the spherical heads at the lower end of the flexible hangers. The front cradle receives its load from the rear end of the driving equalization system through flexible hangers similar to those on the rear cradle.

The spherical heads at the lower ends of the flexible hangers provide for universal angular movement. The first knuckle

joint above these spherical ends allows a forward and backward movement, which compensates for the longitudinal component of the radial action. The transverse movement of the cradle is governed at the top by the heart-shaped link suspension of the flexible hangers. This suspension gives a rigid bearing and assures stable equilibrium while the engine is on straight track; it always tends to insure recentering on leaving a curve. The suspension system is neither attached to nor guided from the frame at any point except where the load is delivered, thereby eliminating a source of wear and relieving the parts of unnecessary stress.

When the truck acts on a curve there is very little angular stress on any one member of the suspension system. Transverse flexibility is provided for, not only at both ends of the flexible links but at the connection between the cradles and

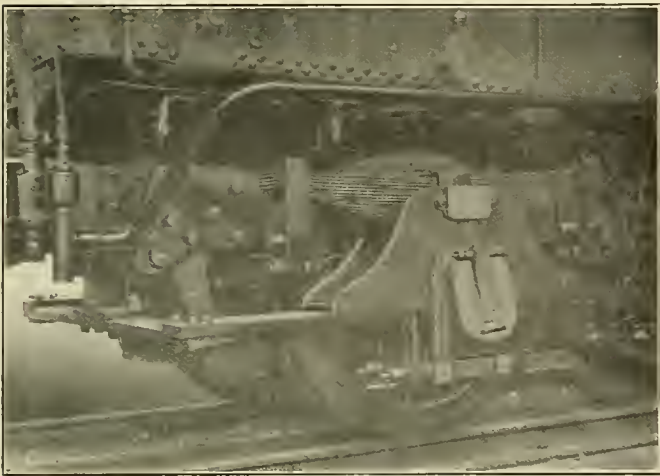

Austin Trailer Truck in Position Under a Locomotive

spring hangers. These trucks have been observed on twenty-three degree curves and their action is excellent in this particular, the compensating effect of the members of the suspension system being particularly noticeable.

The journal boxes are oiled in the usual manner by packing in the cellars. Oil cellars are located on both the inside and outside frame members, the inner oil cellars serving to oil the wheel hubs, and the outer cellar serving as an auxiliary oiler for the crown brass.

The engine frame construction required by this truck is very simple, the only attachment to the main frames being the fulcrum casting at the rear of the truck.

### AUTOMATIC FLANGE LUBRICATOR

A type of flange lubricator for location outside of the cab has recently been brought out, the operation of which is entirely automatic. It consists of an oil tank or reservoir mounted at any convenient location on the running board, a feed nozzle on the flange and between these a ball valve which controls the flow of oil from the reservoir to the flange. This valve is shown in the accompanying illustration. It consists of a body *H* which contains the ball *B* and the plunger *C*, operating the valve *V*. The valve body is installed on road engines with the regulating screw pointing toward the boiler so that any swinging or rolling motion on curves will cause the ball *B* to roll against the plunger *C*, momentarily unseating the ball *B* and permitting oil to flow to the flange. The amount of oil fed to the flange is controlled by the tension of spring *S*. This is regulated by the screw *R* and controls the lift of valve *V*.

On switching locomotives the lubricator body is installed parallel to the center line of the boiler instead of at right angles to it, so that the lubricator is operated by shocks at either end

of the locomotive, such as are caused by a quick stop or by coupling cars. The operation is entirely by gravity, no steam or air connections being required. It is designed to use any kind of oil that will flow freely, and is said to require only suf-

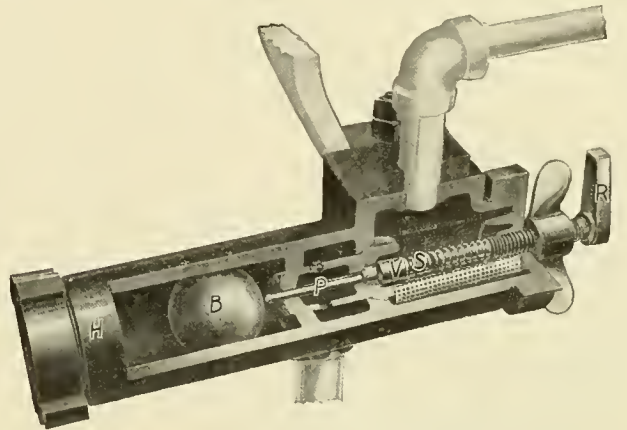

Control Valve of Automatic Flange Lubricator

ficient attention to keep a supply of oil in the tank. It is manufactured by the Detroit Lubricator Company, Detroit, Mich.

### DIRECT OIL DRIVEN AIR COMPRESSOR

The increased use of low grade oil fuel for power purposes has led to the design of the oil engine driven air compressor shown in the illustration. This machine, which is built by the Ingersoll-Rand Company, New York, is of the direct-connected straight line type and the design of the air end somewhat resembles this company's standard line of small compressors.

The feature of greatest interest in this machine is the design of the driving end. This consists of a single oil engine cylinder set behind the air cylinder and directly connected,

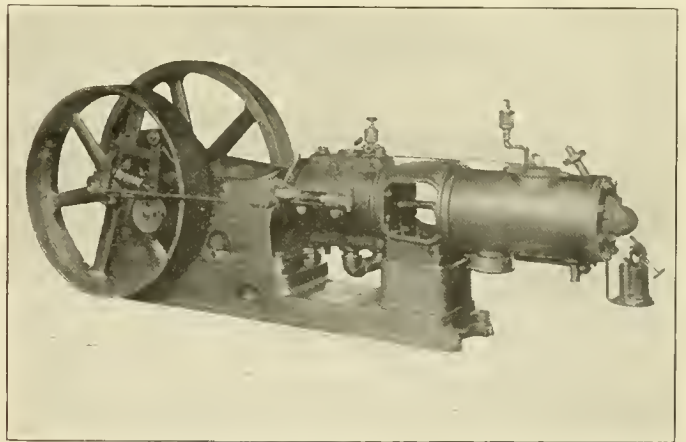

Direct Driven Air Compressor for Low Grade Oil Fuel

by means of an extended piston rod, to the air piston. It follows, in general design, a type known as the hot bulb engine, which is a development of the Diesel engine, and combines a high thermal efficiency with simplicity of construction.

The power cylinder is of the single acting two-cycle type. It is water-jacketed and is supported by a heavy distance piece, reaching to the foundation and bolted to the air cylinder. It is fitted with a torch for heating the ignition bulb preliminary to starting. After the compressor is under way this torch is dispensed with.

The fuel is automatically injected into the combustion



chamber, by means of a small pump on the side of the frame, operated by the main shaft. It enters in the form of a finely atomized spray and is immediately ignited by the hot bulb, dispensing entirely with electric sparking devices. The stroke of the fuel pump is regulated by a centrifugal governor located in the flywheel, thus regulating the amount of fuel injected into the cylinder in proportion to the load. This is supplemented by a regulating device, on the intake to the air cylinder, of the usual design.

The operation of this machine is free from the losses common to the average two-cycle gasoline engine, in which part of the incoming charge follows the exhaust gases through the outlet ports and is wasted. This is due to the fact that the fuel, instead of being vaporized by an outside agency and introduced with the air used for scavenging, is injected directly into the cylinder, at the end of the compression stroke. Since air only is used during the scavenging period of the stroke, the inlet and outlet ports can be so arranged that more thorough scavenging is afforded.

A small quantity of the water from the cylinder jacket is introduced into the combustion space. This water performs the function of regulating the temperature in the cylinder, thereby preventing an undue rise in temperature of the parts, causing disassociation of the fuel. It tends to reduce the maximum pressure in the cylinder while slightly increasing the mean effective pressure, making a smooth running and highly economical machine. The amount of water injected is regulated according to the load on the compressor.

At present this machine is made in but one size with a capacity when running at 325 r. p. m. of 66 cu. ft. of free air at 100 lb. pressure and 73 cu. ft. at 80 lb. pressure. The fuel consumption at this speed, and under average operating conditions, is claimed to be about 2.2 gal. of kerosene per hour. It is adapted to run on either kerosene, fuel oil or distillate.

### HEAVY DUPLEX MILLING MACHINE

Two heavy upright duplex milling machines of the type shown in the illustration were recently furnished to the Pennsylvania Railroad by the Newton Machine Tool Works,

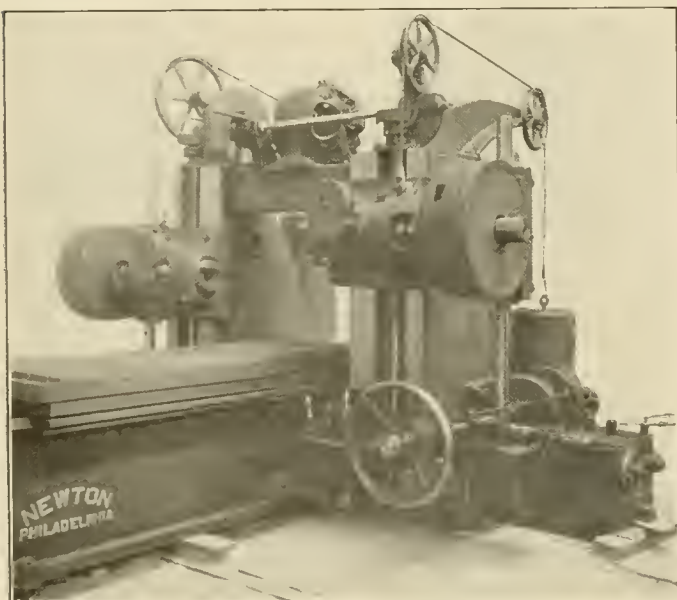

Heavy Upright Duplex Milling Machine

Philadelphia, Pa. This type of machine is adapted to the milling of boxes, shoes, wedges and similar work. When used for slabbing and channeling locomotive rods, an arbor

is placed between the two spindles in order to increase the production by driving the arbor from both ends. The length of the table is 8 ft., the width between uprights is 36 in., and the maximum height from the center of the spindles to the top of the table is 30 in. Each spindle has a maximum in and out adjustment of 10 in.

The spindles rotate in bronze bushed sleeves and are arranged to drive by means of broad face keys and to hold the cutters and arbors in place by means of through retaining bolts. Each spindle is driven by a 35 horse power motor, through a large diameter bronze worm wheel and hardened steel worms. The motor speeds range from 500 to 1,500 revolutions per minute. The drive for each spindle is clutched to permit of independent or simultaneous operation, as desired. The spindle saddles are counterweighted and have independent or simultaneous vertical adjustment by hand, control of which is from either side of the machine. In addition to the hand vertical adjustment, reversing power elevation is obtained by means of a 5 horse power motor mounted on top of the tie beam.

Movement of the table is obtained through a coarse pitch steel rack and angular bronze pinion. Nine changes of feed, ranging from 1/2 in. to 8 in. per minute are obtained without removal of gears, by means of a sliding sleeve feed box. The large hand wheel shown in the illustration is arranged to occupy two positions, one for vertical adjustment of the saddles and the other for adjusting the table. The machine throughout is of very heavy construction, the uprights, the table and the base being heavily ribbed.

### FRICTIONLESS RETURN ROLLER SIDE BEARING

A side bearing of the single-roller type has recently been developed on the Atlantic Coast Line, and is automatically self-centering without the use of springs or inclined surfaces. It is so designed that the roller will not slide, its movement being rolling whether loaded or light.

The principal difference in construction between this and other types of single roller side bearings lies in the method of securing the roller in the housing. Two pins, one on either end, located off center and approximately 90 deg. apart, project into pockets

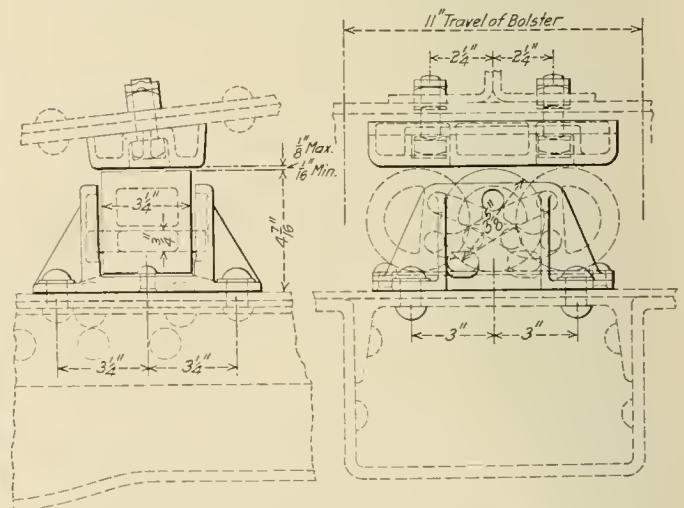

Single Roller, Self Centering Side Bearing

in the housing. These pockets are designed to form guides in which the pins move as the roller revolves. The center of gravity of the roller is located off center, thus causing it to return to the central position automatically. The surface on which the roller moves is without incline, and the adjustment

between it and the body side bearings can therefore be made as close as desired.

Bearings of this type have been in service on the Atlantic Coast Line for nearly a year and the results are claimed to be very satisfactory. The rollers are amply strong for use under cars of any capacity up to 100 tons. Tests have demonstrated that each roller will stand a load of 55 tons before becoming distorted in any way, and 120 tons without being crushed to destruction.

Application for patent has been filed by C. L. Meister, mechanical engineer of the Atlantic Coast Line. The roller is being manufactured by the National Malleable Castings Company, Cleveland, Ohio.

### PNEUMATIC PRESS FOR GENERAL WORK

The 25,000 lb. pneumatic press shown in the accompanying illustrations was developed in the shops of the Central of Georgia at Columbus, Ga. The most important feature of this device is its adaptability to a large variety of bending, straightening and forming operations in connection with the repairing of steel cars, frogs, switches, etc.

A heavy steel table forms the base of the press. Pockets are provided in the table, in which dogs can be placed to keep the work from slipping. The uprights and top cross members are formed of heavy channels. A trolley is provided on the top

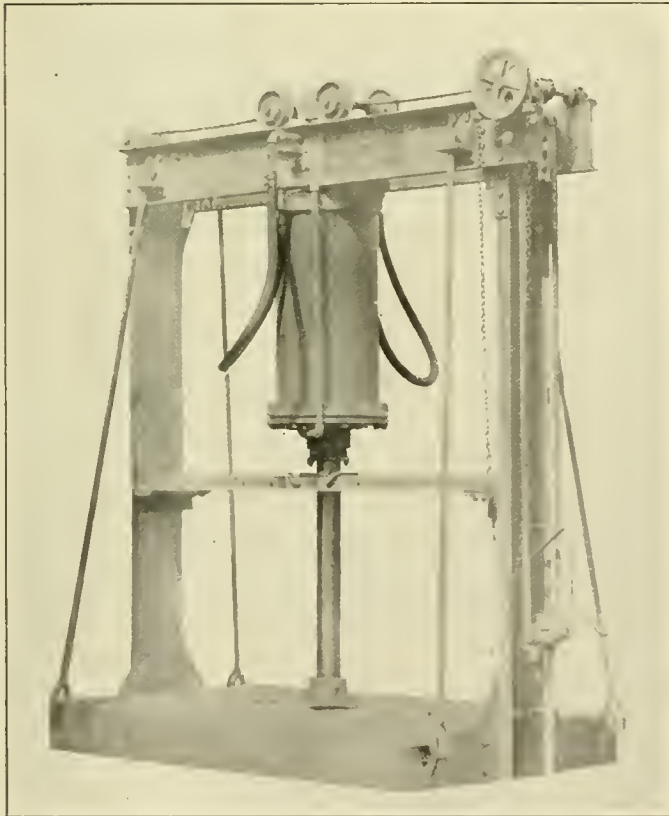

Pneumatic Press Adapted to a Wide Range of Operations

cross members, from which is suspended a 19 in. air cylinder, having a 3 ft. stroke. The cylinder may be moved throughout the entire width of the table by means of a hand chain and gearing on the trolley. The piston rod is 5 in. in diameter and the air cylinder is double acting, so that power can be applied either to push or pull on the rod. The operator's valve is designed to give a very delicate control of the pressure on the piston. The rod is guided by means of a box traveling between two cross channels, which may be securely held at any convenient

point. There are no parts that will be injured by exposure to weather and the press may be installed at any convenient point in the shop yard where compressed air is available.

At the shop of the Central of Georgia, where the original press is still in service, a considerable reduction in the cost of steel car repairs is claimed to have been effected since its installation. The force on this work is stated to have been reduced from 20 to 10 men. Damaged sheets, rolled shapes, sills, etc., from steel cars, truck frames, brake beams and bent drawbars which must be scrapped or put in shape in the blacksmith or boiler shop at considerable expense, can be straightened under the press at a slight cost. With the exception of heavy sills and I beams,

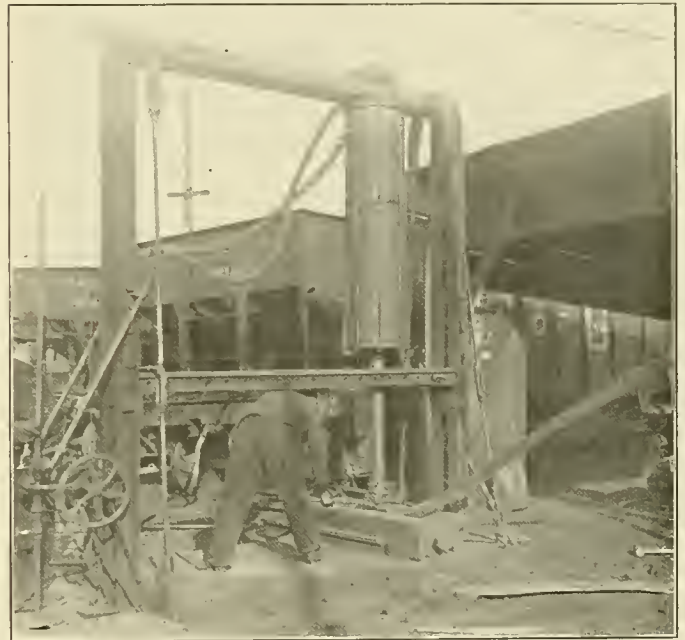

Straightening Steel Car Material with Pneumatic Press

car material is straightened cold and the parts fit, when put together again, without the necessity of reaming rivet holes. The press is very simple and can be operated by common yard laborers without danger of injury to the machine or the operator. It is now being manufactured by the Curtis Pneumatic Machinery Company, St. Louis, Mo.

### VERTICAL SHAPER

The 10 in. vertical shaper shown in the illustrations has been developed by the Pratt & Whitney Company, Hartford, Conn. It is especially adapted to die cutting, and the tool post construction permits the use of unusually short tools on outside work.

The rotary table is mounted on dove-tailed bearings which are provided with taper gibs for maintaining the proper relation between the bearing surfaces. Both hand and power control of the longitudinal, transverse and rotary feeds is provided. A quick indexing mechanism also forms part of the construction, whereby the table may be rotated  $\frac{1}{2}$ ,  $\frac{1}{3}$ ,  $\frac{1}{4}$ ,  $\frac{1}{6}$  or  $\frac{1}{12}$  of a revolution by disengaging the regular worm hand feed and turning the table by hand.

The ram driving mechanism provides a quick return stroke and is arranged to afford a convenient method of adjusting the length of the stroke by means of the dial shown on the side of the machine. A clutch, the lever of which is shown in the illustration, provides a means entirely independent of the countershaft for controlling the ram.

Angular adjustment of the ram is accomplished by mounting it in an independent bearing, the upper part of which is



pivoted on a trunnion, enabling the bearing and the ram to be swung on an angle, suitable graduation in degrees being provided. The ram bearing fits throughout its length in the

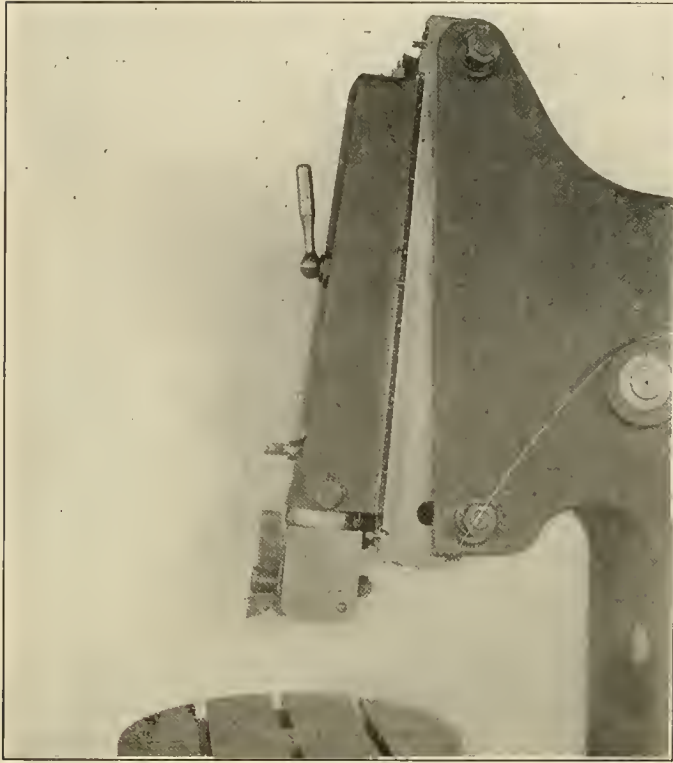

Head of Vertical Shaper, Showing Angular Adjustment

upright and is longer than the ram, providing adequate support for the maximum length of stroke.

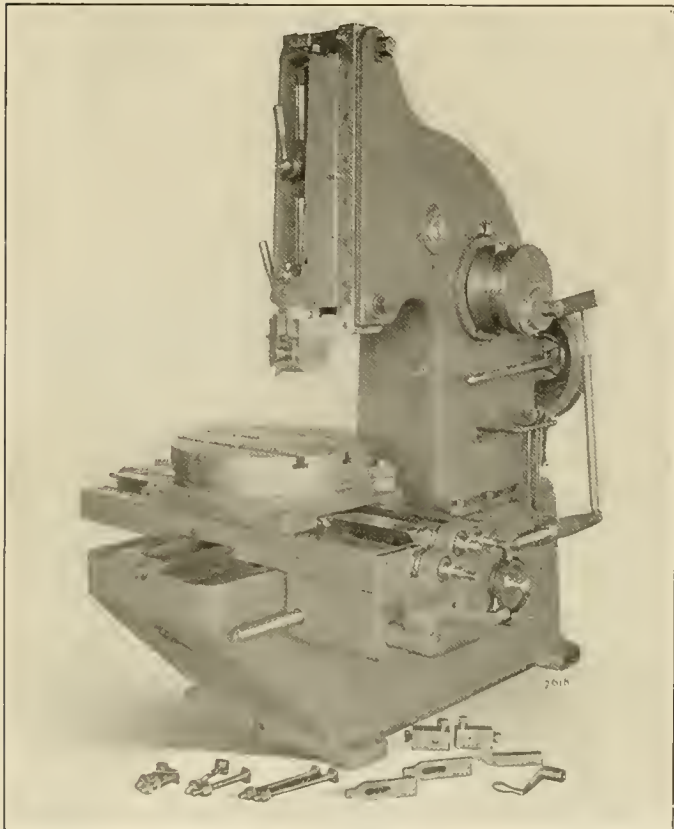

Ten-Inch Vertical Shaper

A swiveling ram head is provided which enables the operator to adjust the tool in the most advantageous position and permits the planing of two or more sides of the work at one setting. The tool post is designed to clamp from the back, thus eliminating the projection of the clamping screw beyond the cutting edge of the tool. This construction permits the use of short tools on external work.

The angular adjustment to the ram of this machine makes it especially adaptable to the cutting of dies as the ram may be set to give the desired clearance below the cutting edge of the die.

## CAR CLOSET

A type of car water closet has recently been developed by the Dayton Manufacturing Company, Dayton, Ohio, which possesses several new features. Before its introduction it was necessary to mount the supply valve at the back of the hopper and below the top. In this position the valve is difficult of access for repairs without disconnecting the pipes and operating connections, and removing the hopper from its fixed position.

In this type of closet the supply valve is mounted on the side wall in an accessible position. It is operated by the customary



Car Water Closet with Separate Supply Valve

lever handle, which is also connected through adjustable rods to the dump pan shaft. The hopper may be set at any angle, and as close to the walls as may be necessary, standard pipe connections leading from the wall valve to the rear of the hopper. The valve is always immediately accessible for renewing gaskets, and it is ordinarily unnecessary to break the pipe connections after the closet is once installed. The closet is adapted for either gravity or air pressure water supply. When air pressure is to be used, a special adjusting valve is furnished.

BRIDGE ACROSS THE HUDSON.—At a highly respectable meeting held at Albany on Wednesday, February 4, a committee of 30 was appointed to draw up a petition to the Legislature on the subject of a bridge across the Hudson.—*From American Railroad Journal, February 14, 1835.*

# NEWS DEPARTMENT

Five thousand employees of the Baltimore & Ohio, from points east of Pittsburgh and Parkersburg, will hold their thirty-third annual reunion at Harper's Ferry, W. Va., on July 30.

Two men, who recently held up an Illinois Central passenger train in Louisiana, have been indicted at Amite City, La., for murder. The negro porter on the train was shot by the robbers and died soon afterward.

At the Anglo-American Hundred Years Peace Exposition, now open in London, the Southern Railway has the only exhibit made by an American railway. It is a handsome display of the agricultural, horticultural and mineral products of the southern states.

By the new time tables adopted recently, the New York, New Haven & Hartford discontinues 163 passenger trains, making a saving of 3,350 train miles a day. It is said that these trains have been found to be earning less than 50 cents a mile. The Philadelphia & Reading has discontinued a number of short-trip passenger trains.

The Union Pacific is to show at the Panama-Pacific International Exposition at San Francisco, next year, a reproduction of the notable features of Yellowstone National Park, and it has been estimated that the cost of the display will be \$500,000. This display will occupy four acres of ground near the eastern entrance to the exposition enclosure.

On the Pennsylvania Railroad, by a recent order, whenever passenger coaches are crowded, a train man must announce the number of seats available in other coaches, and must tell the number of seats available in each coach. Special care must be exercised at the larger terminals where passengers are liable to be inconvenienced by the congestion of travel.

The Erie Railroad, when sued recently by a milkman for \$25,000 damages on account of an injury received when he drove his horse and wagon on a highway crossing, and was struck by a locomotive, replied with a counter claim of \$100 for damage to the locomotive, declaring that the plaintiff had approached the crossing at a rapid, reckless and dangerous rate of speed.

Eleven thousand Italians are employed on the Pennsylvania Railroad, and the company has issued a leaflet telling something of their activities. These men are not all laborers, a list being given showing twenty-five or more different occupations, in which they are engaged. On the Pittsburgh division there are twenty-seven Italian track foremen and 42 assistant foremen. More than 2,000 Italian employees of the road are studying English in a correspondence course, maintained by the company for their benefit.

Dr. Harold Pender, professor of electrical engineering at Massachusetts Institute of Technology, and director of the research division of the department of electrical engineering, has been appointed professor-in-charge of the department of electrical engineering at the University of Pennsylvania, to take the place next fall. Heretofore the departments of mechanical and electrical engineering at the University of Pennsylvania have been under the joint direction of the Whitney professor of dynamical engineering. From the beginning of next year the department of electrical engineering will be on an independent and co-ordinate footing with the departments of civil and mechanical engineering.

The musophone is being installed in the new terminal station of the Canadian Pacific at Windsor street, Montreal. The "muso-

lophone" is a telephone with a large receiver used to announce trains in the waiting rooms and other parts of the station, a single announcer talking into a telephone transmitter which is connected with as many receiving instruments as may be desired. It appears that devices of this kind, of three or more different makes, are now in experimental use in one or more cities. The device in the Grand Central Terminal, New York City, which was installed there two or three years ago, is now used only in the smaller rooms, the large central waiting room having developed such loud and troublesome echoes that the use of the telephone arrangement was given up.

On June 13 and 16 the Long Island Railroad carried more than 50,000 people between New York and the polo grounds at Meadow Brook, Long Island, all without accident to either passengers or employees. About 15,000 passengers were taken to Manhattan and Brooklyn after Tuesday's game was over. Saturday, the 13th, was one of the biggest days the Long Island Railroad has ever had, in that it carried, on all its lines, about 300,000 passengers, 23,000 of whom were passengers to and from the first polo game. Twenty-four trains were unloaded at Meadow Brook on Tuesday in little more than an hour; and all this business was handled on a single track branch line which ordinarily is but little used for traffic. The Pennsylvania station, New York, which is the Long Island terminal in Manhattan, received and despatched more trains in the four days ending Tuesday midnight than during any similar period since the station was opened to the public. In these four days over 1,600 trains were handled there, and it is estimated that 750,000 people availed themselves of the facilities of the station, while the number of passengers arriving and departing was over 570,000, an average of more than 142,000 per day. The largest number using the station in any one day was on Saturday, approximately 170,000. All of the additional traffic was handled without any delay to the regular trains.

## A CORRECTION

G. E. Sisco, assistant engineer of motive power of the Pennsylvania Lines West, advises that the statement made in his discussion of the paper on Front End Design and Air Openings of Grates and Ash Pans, before the International Railway Fuel Association and reported in the Railway Age Gazette, Mechanical Edition, June, 1914, page 285, giving the evaporation per hour for the locomotive with elliptical nozzle as 58,882 lb., should have been 53,882 lb.

## NEW RAILROAD Y. M. C. A. BUILDING IN NEW YORK

The railroad branch of the Young Men's Christian Association of New York City, which is the title of the well-known institution on Madison avenue near the Grand Central Terminal, has moved into a new building which has been built on the east side of Park avenue, between Forty-ninth and Fiftieth streets. The building which has been occupied for the past 25 years is to be torn down to make way for extensions of the Grand Central Terminal. The new building stands on steel columns above the tracks of the yard, about 1,000 ft., or four blocks, north of the northerly front of the station. It is 200 ft. long, 47 ft. deep and seven stories high, of cream colored pressed brick trimmed with Indiana limestone. On the right of the main entrance hall is a social room 40 ft. x 70 ft., adjoining which is a reading and writing room. This floor, in addition to the usual facilities, has a barber shop and a billiard room.

On the second floor is a restaurant having three dining



rooms, with a total seating capacity of 320. The association intends to run a model dining room and kitchen, both to be open at all times to visitors. Prices of meals will range from ten cents to fifty cents, the popular luncheon being 30 cents, table d'hôte. The kitchen is 130 ft. by 27 ft., and adjacent to it are a rest room and a dressing room for the waitresses. The third floor has a gymnasium 40 ft. by 75 ft., two full stories in height, with a spectators' gallery. This room has a stage and a dressing room, and when used as an auditorium will seat 500 persons. On this floor there are bowling alleys and class rooms for night schools; also the association library and a dark room for the Camera club. On the fourth floor there is a lecture room, seating 125 persons; and the balance of this floor, together with the fifth, sixth and seventh stories will be used entirely for dormitories, having a sleeping capacity for 226 men. The sleeping rooms average 6 ft. by 17 ft., and all have outside windows. On the roof there are tennis and hand ball courts.

This association was started in October, 1875, and Cornelius Vanderbilt, grandson of Commodore Vanderbilt, was its most liberal patron. He gave the building which has now been abandoned, the railroad company furnishing the land. For the new building at Forty-ninth street William K., Frederick W. and Alfred G. Vanderbilt have given \$100,000 each, and the two railroad companies have given large sums. The right to the site is held by a long lease.

#### THE UNIVERSITY OF PITTSBURG RAILWAY MECHANICAL ENGINEERING COURSE

The school of engineering of the University of Pittsburg is going to offer, beginning with the fall of this year, a comprehensive course in railway mechanical engineering and administration in which instruction will be given in such subjects as materials of railway engineering, operating units, railway design, utilization of locomotives and cars, railway shop methods, fundamentals of railway practice, etc. L. E. Endsley, now connected with the railway course at Purdue University, has been made a professor in the new course with the title of professor of mechanical railway engineering. Mr. Endsley is at present professor of railway mechanical engineering at Purdue, and has been with that school since his graduation from it in 1901. In 1903, he was appointed instructor in the locomotive laboratories of the university. He was advanced two years later to assistant professor, and in the following year became associate professor of railway mechanical engineering. In 1908 he was appointed professor of railway mechanical engineering and was given direct charge of the Master Car Builders' laboratory, which is located at Purdue University. In that way he has had charge of the tests conducted on the brake shoe testing machine of the Master Car Builders' Association for the last 12 years. He has also conducted a great many tests pertaining to superheated steam, and has presented papers relating to that work before the Master Mechanics' Association. Mr. Endsley was in direct charge of the locomotive laboratories during the tests on locomotive front ends, conducted by the Master Mechanics' Association. He also conducted, some years ago, for the American Steel Foundries



Copyright by Moffett, Chicago.

L. E. Endsley

some interesting tests on the construction of the freight car truck as affected by the different degrees of curvature. The new department in which Mr. Endsley has become a professor, is under the direction of D. F. Crawford, general superintendent of motive power of the Pennsylvania Lines West of Pittsburgh.

#### ELECTRICAL ENGINEERING RESEARCH AT THE MASSACHUSETTS INSTITUTE OF TECHNOLOGY

The activities in electrical engineering research at the Massachusetts Institute of Technology have developed very rapidly during the past year and a noteworthy extension of the organization for administering the researches has recently been effected. This has been aided by the co-operative agreement between Harvard University and the Institute of Technology whereby the departments of electrical engineering in the two institutions were practically merged.

By this new organization for the research laboratory there is created a research committee, to whom reports are made upon the progress of the various researches. The committee comprises the following members of the electrical engineering department staff: those who are supervising or actively engaged in research work in the research laboratory; those who are personally carrying on research work in any branch of the department; and those who have completed a reorganized piece of research work during the preceding year. The research committee, as a whole, will meet once a month during the school term, such meetings being open to all members of the department staff. The chairman of the research committee is also chairman of the executive committee of three members, who will carry on the executive work of the general committee. By this arrangement the research activities of the department will be brought into close relation with the regular teaching work. Thus, any member of the staff, whether professor, instructor, or assistant, who desires to carry out any original investigation may become identified with the research work through the research committee. Some of the special resources of the research laboratory which have not been designated for use in a particular investigation may be used in providing such a man with apparatus and other laboratory facilities. Even if a member of the department staff is not able to devote a considerable portion of his time to an experimental investigation, he still has the opportunity of offering suggestions upon the conduct of investigations which are being made by others. From the standpoint of the younger members of the staff, the opportunities of entering the enthusiastic atmosphere which accompanies the successful conduct of original research are most unusual.

The staff of the research laboratory at present includes six research associates and assistants who give their whole time to research. This number will be increased to nine on July 1, 1914. In addition to the work of these men, who are appointed by the institute, the theses of four students who are candidates for advanced degrees in electrical engineering have been carried on in the research laboratory during the past year. The study of a wide variety of problems has already been undertaken by the laboratory.

#### MEETINGS AND CONVENTIONS

*International Railway Fuel Association.*—It is announced that the seventh annual convention of the International Railway Fuel Association will be held at Chicago, May 17-20, 1915.

*Air Brake Association.*—The executive committee of the Air Brake Association has decided that the twenty-second annual convention of the association will be held May 5-7, 1915, at the Hotel Sherman, Chicago.

*International Railway General Foremen's Association.*—Wm. Hall, secretary-treasurer of the International Railway General Foremen's Association, has moved his office from 829 to 914 West Broadway, Winona, Minn.

*Seventh Congress of the International Association for Testing Materials.*—The seventh congress of the International Association for Testing Materials will be held under the patronage of the Czar of Russia, in St. Petersburg, August 12-17, 1915. Four days will be devoted to the discussion of the most important problems on testing materials. After the congress extensive excursions in the interior of Russia have been arranged.

*American Railway Tool Foremen's Association.*—The sixth annual convention will be held in Chicago, July 20-22, at the Hotel Sherman. The following is the program: July 20, 9:30 a. m.—Opening address; Standardization of Reamers for Locomotive Repairs; Machine Tool Repairs.

July 21.—Special Tools for Drilling, Reaming and Milling; Tool Room Grinding; address: Safety First in Grinding.

July 22.—Distribution of Tools for Shop Use; Dies for Cold Work, Press and Special Punching.

*Chief Interchange Car Inspectors' and Car Foremen's Association.*—The annual convention of this association will be held in the Hotel Sinton, Cincinnati, Ohio, August 25-27. The prospects are that it will be one of the largest and most important meetings in the history of the association, and every one who can possibly attend is urged to do so. It is being recognized by car department officers that the interpretation given to the M. C. B. rules of interchange at the meetings of this association are of great help to all those concerned in the interchange of cars.

*International Railway General Foremen's Association.*—The outlook for a good convention this year is very bright; assurances are being received from many members of their intention to attend, and they are being encouraged by their superintendents of motive power not only to attend the convention, but also to become members of the association. Advance copies of the various papers were sent out to all the members 30 days prior to the convention, and all concerned should read these papers over carefully. It is expected that a new departure will be made at this convention, in that the topics will be announced from the chair, and the members will proceed at once with the discussion, thus dispensing with the lost motion of reading the paper through first, so that unless the papers have been read before they are taken up in the convention, they cannot be discussed intelligently.

*The following list gives names of secretaries, dates of next or regular meetings, and places of meeting of mechanical associations.*

**AIR BRAKE ASSOCIATION.**—F. M. Nellis, 53 State St., Boston, Mass. Convention, May 5-7, 1915, Hotel Sherman, Chicago.

**AMERICAN RAILWAY MASTER MECHANICS' ASSOC.**—J. W. Taylor, Karpen building, Chicago.

**AMERICAN RAILWAY TOOL FOREMEN'S ASSOCIATION.**—A. R. Davis, Central of Georgia, Macon, Ga. Convention, July 20-22, 1914, Hotel Sherman, Chicago.

**AMERICAN SOCIETY FOR TESTING MATERIALS.**—Prof. E. Marburg, University of Pennsylvania, Philadelphia, Pa.

**AMERICAN SOCIETY OF MECHANICAL ENGINEERS.**—Calvin W. Rice, 29 W. Thirty-ninth St., New York.

**CAR FOREMEN'S ASSOCIATION OF CHICAGO.**—Aaton Kline, 841 North Fifthth Court, Chicago; 2d Monday in month, except July and August, Lytton building, Chicago.

**CHIEF INTERCHANGE CAR INSPECTORS' AND CAR FOREMEN'S ASSOCIATION.**—S. Skidmore, 946 Richmond street, Cincinnati, Ohio. Convention, August 25-27, 1914, Cincinnati, Ohio.

**INTERNATIONAL RAILWAY FUEL ASSOCIATION.**—C. G. Hall, 922 McCormick building, Chicago. Convention, May 17-20, 1915, Chicago.

**INTERNATIONAL RAILWAY GENERAL FOREMEN'S ASSOCIATION.**—William Hall, 914 W. Broadway, Winona, Minn. Convention, July 14-17, 1914, Hotel Sherman, Chicago.

**INTERNATIONAL RAILROAD MASTER BLACKSMITHS' ASSOCIATION.**—A. L. Woodworth, Lima, Ohio. Convention, August 18-20, 1914, Milwaukee, Wis.

**MASTER BOILER MAKERS' ASSOCIATION.**—Harry D. Vought, 95 Liberty St., New York.

**MASTER CAR BUILDERS' ASSOCIATION.**—J. W. Taylor, Karpen building, Chicago.

**MASTER CAR AND LOCOMOTIVE PAINTERS' ASSOC. OF U. S. AND CANADA.**—A. P. Dane, B. & M., Reading, Mass. Convention, September 8-11, 1914, Nashville, Tenn.

**NIAGARA FRONTIER CAR MEN'S ASSOCIATION.**—E. Frankenberger, 623 Brisbane building, Buffalo, N. Y. Meetings monthly.

**RAILWAY STOREKEEPERS' ASSOCIATION.**—J. P. Murphy, Box C, Collinwood, Ohio.

**TRAVELING ENGINEERS' ASSOCIATION.**—W. O. Thompson, N. Y. C. & H. R., East Buffalo, N. Y. Convention, September 15, 16, 17 and 18, 1914, Hotel Sherman, Chicago, Ill.

## PERSONALS

*It is our desire to make these columns cover as completely as possible all the changes that take place in the mechanical departments of the railways of this country, and we shall greatly appreciate any assistance that our readers may give us in helping to bring this about.*

### GENERAL

C. O. DESTICHE has been appointed superintendent of motive power of the South Dakota Central, with office at Sioux Falls, S. D., succeeding H. J. Osborne, resigned.

A. C. HINCKLEY, superintendent of motive power and machinery of the Oregon Short Line, has moved his office from Salt Lake City, Utah, to Pocatello, Idaho.

WILLIAM T. KUHN has been appointed superintendent of motive power of the Toronto, Hamilton & Buffalo, with office at Hamilton, Ont. Mr. Kuhn was born in 1872 at East Radford, Va. He was educated at the Radford high school and took the complete mechanical course in the Scranton Correspondence School. He began railroad work in 1888 on the Norfolk & Western as an apprentice machinist. In the following two years he worked as machinist, roundhouse foreman and assistant air brake instructor. In 1900 he went to the Lake Shore & Michigan Southern as roundhouse foreman, and later was made mechanical inspector, with duties which included the inspection of new locomotives. In March, 1911, he was appointed assistant master mechanic of the Lake Erie & Western, and in October of the same year went to the Toronto, Hamilton & Buffalo as master mechanic, which position he held until his present appointment.

HARVEY SHOEMAKER has been appointed mechanical superintendent of the Bangor & Aroostook, with office at Derby, Me., succeeding R. Q. Prendergast, resigned. Mr. Shoemaker began railroad work in 1886 on the Lehigh Valley at Wilkesbarre, Pa., as a machinist. Before 1901 he had been made gang foreman and then general foreman of this shop. In 1901 he was appointed general foreman of the locomotive department of the Delaware, Lackawanna & Western, in charge of the Scranton shops. In 1903 he was made master mechanic of the Scranton division, holding this position until May, 1911, when he went to the New York, Ontario & Western in charge of shop construction work at Middletown, N. Y. After the shops at that place had been completed, he was made shop superintendent, which position he held until June 1, 1914.

### MASTER MECHANICS AND ROAD FOREMEN OF ENGINES

DAVID GRATTON has been appointed master mechanic of the Oregon Short Line at Pocatello, Idaho.

A. GUILD has been appointed master mechanic of the Hawaii Railway at Makukona, Hawaii.

R. E. HAMMOND has been appointed acting road foreman of engines of the Northern Pacific at Minneapolis, Minn., in place of John Horan.

J. M. O. HOLLMAN has been appointed master mechanic of the North Louisiana & Gulf at Hodge, La.

JOHN HORAN, road foreman of engines of the Northern Pacific at Minneapolis, Minn., has been appointed acting master mechanic at that point, succeeding J. B. Neish.

D. J. MALONE, master mechanic of the Oregon Short Line at Ogden, Utah, has been transferred to Pocatello, Idaho.

J. B. NEISH, master mechanic of the Northern Pacific at Minneapolis, Minn., has been granted leave of absence.

J. C. SCHEPP, general foreman of shops of the Texas & Pacific at Marshall, Tex., has been appointed master mechanic at Texarkana, Tex., succeeding George M. Lovett.



F. STONE has been appointed road foreman of engines of the Chicago & Alton at Slater, Mo.

#### CAR DEPARTMENT

J. M. HAWKINS has been appointed car foreman of the Chicago, Rock Island & Pacific at Eldon, Mo., succeeding G. N. Dorr, transferred.

N. B. JONES has been appointed car foreman of the Canadian Pacific at Kenora, Ont., succeeding H. K. York, transferred.

B. F. ORR has been appointed division car foreman of the Cleveland, Cincinnati, Chicago & St. Louis at Indianapolis, Ind.

H. K. YORK, formerly car foreman of the Canadian Pacific at Kenora, Ont., has been appointed car foreman at North Transcona, Man.

#### SHOP AND ENGINE HOUSE

J. A. CARLESTON has been appointed general foreman of the Texas & Pacific at Marshall, Tex., succeeding J. C. Schepp, promoted.

D. D. COSSAR, night locomotive foreman of the Canadian Pacific at Moose Jaw, Sask., has been appointed locomotive foreman at North Transcona, Man.

B. E. GREENWOOD has been appointed foreman of the power house of the Norfolk & Western at Bluefield, W. Va.

W. F. HEINBACH has been appointed engine house foreman of the Philadelphia & Reading, at East Penn Junction, Pa.

F. JOHNSON has been appointed night locomotive foreman of the Canadian Pacific, at North Transcona, Man.

E. MARSHALL, formerly general foreman of the Canadian Pacific at McAdam Jct., N. B., has been appointed locomotive foreman at Bay Shore, N. B.

A. J. PENTLAND, formerly night locomotive foreman of the Canadian Pacific at Swift Current, Sask., has been appointed locomotive foreman at Ignace, Ont., succeeding H. J. Reed, transferred.

G. T. SCHROEDER has been appointed day roundhouse foreman of the Chicago, Rock Island & Pacific at Manly, Iowa, succeeding N. J. Lawson, resigned.

A. STURROCK, formerly erecting shop foreman of the Canadian Pacific at Vancouver, B. C., has been appointed general foreman at Ogden Shops, Calgary, Alta.

W. WELLS has been appointed general foreman of the Canadian Pacific at McAdam Jct., N. B., succeeding E. Marshall, transferred.

F. L. WILLIS, formerly assistant locomotive foreman, has been appointed locomotive foreman of the Canadian Pacific at McAdam Jct., N. B.

W. WURTMAN, gang foreman of the Canadian Pacific, at Winnipeg, Man., has been appointed erecting shop foreman at Vancouver, B. C., succeeding A. Sturrock, promoted.

#### PURCHASING AND STOREKEEPING

ERNEST BAXTER has been appointed purchasing agent of the St. Louis Southwestern, with headquarters at St. Louis, Mo., succeeding J. E. Sargeant.

H. B. MARTIN has been appointed purchasing agent of the Coal & Coke Railway, with office at Elkins, W. Va.

#### OBITUARY

WALTER J. EDDINGTON, general foreman of the Atchison, Topeka & Santa Fe at Corwith, Ill., died at his home in Chicago on May 29, aged 65 years.

D. C. CHENEY, fuel inspector of the Chicago, Milwaukee & St. Paul, died at his home in Chicago on May 29, aged 60 years. He had been connected with the St. Paul since 1873, beginning as a telegraph operator and filling successively the positions of assistant train dispatcher, chief dispatcher, trainmaster, division superintendent, and general superintendent of the Middle district, until 1910, when he was appointed fuel inspector.

Alexander Stewart, general superintendent of motive power and equipment of the Southern Railway, with office at Washington, D. C., died suddenly at the Hotel Continental in Paris,



A. Stewart

France, on June 28. Mr. Stewart had been in bad health for several months and, on June 16 accompanied by his wife and only daughter, sailed on the *Mauretania* for Bad Nauheim, Germany, where it was hoped he would fully regain his health. Mr. Stewart was 46 years old and widely known in the railroad world as one of the most capable and experienced men of his profession. He was born at Fort Wayne, Ind., and began at an early age to prepare for the railroad business. He entered the service of the Union Pacific as ma-

chinesist's apprentice, and after serving his apprenticeship, worked consecutively as machinist, foreman, general division foreman and then as master mechanic at Cheyenne, Wyo. In 1903 he left the service of the Union Pacific to go to the Southern Railway as division master mechanic at Knoxville, Tenn. A little later he was promoted to general master mechanic of the Western district, and on April 1, 1904, he was appointed mechanical superintendent of the same road. Two years later he was promoted to general superintendent of motive power and equipment, with headquarters at Washington, D. C., and also chairman of the Committee on Mechanical Standards of the Southern Railway and the following affiliated lines: Alabama Great Southern; Cincinnati, New Orleans & Texas Pacific; Mobile & Ohio and Georgia Southern & Florida railroads, which positions he held at the time of his death. In 1910 he attended the International Railway Congress at Berne, Switzerland, as a delegate, and in 1911 was elected president of the Master Car Builders' Association; he was also a member of the Master Mechanics' Association. There was no man who was held in higher esteem than Mr. Stewart by his associates, as well as those who served under him, and he was widely known in fraternal and club circles.

RAILWAY EXTENSION IN THE PHILIPPINES.—The Manila Railway has altogether about 10,000 men at work on the various extensions of its line now in course of construction. Included in the list of projects which are under way are: a branch to Bagnico; a branch from San Francisco to Arayat; a branch from Panique to Rosales, San Quintin and Tayug and a division from Albay to Neuva Caceres. The branch from Panique to Rosales is complete to about eight miles from San Quintin. North of Aringay, the track extension is delayed at the Naguilian river, eight miles south of San Fernando where a bridge of 11 spans, 150 ft. each in length, is being built. This will be the largest bridge in the Philippines. It is also hoped to open a branch from Lucena towards Laguiminoc in July.

## SUPPLY TRADE NOTES

Dudley A. Johnson has been appointed branch manager of the Chicago office of the Joseph Dixon Crucible Company, succeeding the late Sam Mayer.

The American Hoist & Derrick Company, St. Paul, Minn., has moved its Seattle office from 613 Western avenue to 1512 L. C. Smith building.

W. D. Jenkins, 1408 Whitney Central building, New Orleans, La., has been appointed southern representative of the Union Railway Equipment Company, Chicago.

H. W. Green, for the past ten years district sales agent for the American Steel Foundries in Pittsburgh, has been elected vice-president of the Lawrence Steel Casting Company, Pittsburgh, Pa.

James M. Swank, at one time editor of Iron Age and formerly vice-president and general manager of the American Iron & Steel Association, died at his home in Philadelphia on June 22.

C. H. McCormick, formerly district manager of the Standard Heat & Ventilation Company at Cincinnati, Ohio, has been promoted to the position of vice-president, with office at 1949 Peoples Gas building, Chicago.

Charles Neilson, formerly general manager of the Cincinnati, Hamilton & Dayton, and before that superintendent on the Erie, has opened an office as consulting engineer at Room 1642, 30 Broad street, New York City.

The Taylor-Wharton Iron & Steel Company, High Bridge, N. J.; Wm. Wharton, Jr., & Company, Inc., Philadelphia, Pa., and the Tioga Steel & Iron Company, Philadelphia, Pa., have removed their Seattle office to 1604 L. C. Smith building.

L. R. Pomeroy, the well known railway and electrical engineer, has been appointed manager of the New York sales office of the United States Light & Heating Company, of Niagara Falls, with office at 24 West Sixty-first street. Mr. Pomeroy has been in the railroad and railroad supply business for more than thirty-five years, and has a very wide acquaintance. He was born at Port Byron, N. Y., in 1857, and was educated at Irving Institute, Tarrytown, N. Y. From 1880 to 1886 he was secretary and treasurer of the Suburban Rapid Transit Company, of New York, and then for nine years he was with the Carnegie Steel Company, introducing basic boiler steel for locomotives and special forgings. Subsequently he engaged in the same kind of work with the Cambria Steel Company and the Latrobe Steel Company jointly. For three years to 1902 he was assistant general manager of the Schenectady Locomotive Works, and then for six years represented in the railway field the General Electric Company. He then went to the Safety Car Heating & Lighting Company, and afterwards to J. G. White & Co. as chief engineer of the railway and industrial divisions. For some time past he has been engaged as a consulting engineer.



L. R. Pomeroy

The second-hand locomotive, car and railway equipment business of the late J. T. Gardner will be continued under the name of James T. Gardner, Inc., with M. Gardner, president; R. H. Gardner, vice-president; A. V. Talbot, secretary and general manager, and A. M. Talbot, treasurer. Offices in the Railway Exchange, Chicago.

H. P. Webb, St. Louis, Mo., has been appointed railway sales agent for the St. Louis territory by the Union Fibre Company of Winona, Minn. During the last few years Mr. Webb has been in the railway supply business at St. Louis, and previous to that time he was connected with the purchasing departments of several of the St. Louis railroads.

The Titanium Alloy Manufacturing Company, Niagara Falls, N. Y., has organized a bronze department for the manufacture of titanium-bronze specialties under its various patents. Wm. M. Corse, formerly works manager of the Lumen Bearing Company, Buffalo, and lately general manager of the Empire Smelting Company, Depew, N. Y., will be made manager of the new department.

The Niles-Bement-Pond Company was awarded the first prize of \$20,000 in the contest announced last year by the Chilean Government for the best design for a general railroad shop. The awards were made the first week in June, the second prize of \$10,000 going to a combination Belgian and English concern. It is expected that the shops will cost \$3,000,000.

E. P. Dillon and M. B. Lambert, both of whom have been connected with the railway and lighting department of the Westinghouse Electric & Manufacturing Company, East Pittsburgh, Pa., for a number of years, have been appointed to the new positions of assistant managers of the railway and lighting department. Mr. Dillon will have charge of the commercial activities of the company in connection with the generation and distribution of power involving power house substations, transformer stations and similar apparatus. Mr. Lambert will have charge of all sales work pertaining to electric traction, including steam, interurban and city railroads.

## NEW SHOPS

ATCHISON, TOPEKA & SANTA FE.—This company has authorized the construction of a reinforced concrete engine house, crane runway, radial tracks and turntable, at Albuquerque, N. M., at an approximate cost of \$100,000.

SAVANNAH & STATESBORO.—This road has just completed a one storey 66 ft. x 72 ft. repair shop at Statesboro, Ga.

THE LOUISVILLE AND PORTLAND CANAL.—The number of steamboats which passed through the Louisville and Portland Canal during the year 1834, was 938; the number of keel and flat boats 623; the total tonnage was 162,000 tons, and the amount of tolls received thereon \$61,848.17.—*From the American Railroad Journal, February 14, 1835.*

CAMDEN AND AMBOY RAILROAD.—This afternoon the following resolution was called up in the Council on its final passage, and carried by a vote of 11 to 2: "Resolved. That the passage of any act by the Legislature, authorizing or recognizing any other railroad across this state, which shall be intended or used for the transportation of passengers or merchandise between Philadelphia and New York, would be unjust, impolitic, in violation of the faith of the state, and deeply injurious to its interests."—*Extract from a letter dated Trenton, February 17, 1835, in the American Railroad Journal, February 28, 1835.*



## CATALOGS

**ROPE DRIVES.**—The Mesta Machine Company, Pittsburgh, Pa., has issued bulletin O dealing with that company's rope drive system for power transmission. The bulletin contains eight pages and includes a number of illustrations of typical installations.

**AIR HOISTS.**—Catalog No. 107, superseding No. 93, from the Whiting Foundry Equipment Company, Harvey, Ill., deals with the subject of air hoists. A number of illustrations are included as well as a table of sizes. This catalog will be sent free on request.

**HAND TRAVELING CRANES.**—Catalog P from the Brown Hoisting Machinery Company, Cleveland, Ohio, contains 36 pages and is devoted to the hand traveling cranes built by this company. The booklet is completely illustrated and contains price lists and other data.

**CAR DOOR FASTENERS.**—The Universal Car Seal & Appliance Company, Albany, N. Y., has issued a leaflet dealing with the Universal car door fastener. The leaflet includes illustrations which show very clearly the construction and application of this fastener to a car door.

**WAGON AND TRUCK LOADERS.**—This is the subject of book No. 190 issued by the Link Belt Company, Chicago. The book contains 32 pages and illustrates and describes a variety of loaders working on the link belt principle and used for loading loose material from ground storage.

**BRAKE BEAMS.**—A 28-page catalog recently received from the Buffalo Brake Beam Company, 30 Pine street, New York, is devoted to the brake beams and brake beam details manufactured by this company. The catalog is well illustrated and contains dimensioned drawings of a number of the beams.

**PRESSED STEEL TRUCKS.**—A ten-page folder recently issued by the Pressed Steel Truck Company, Pittsburgh, Pa., deals with the Atlas indestructible pressed steel hand truck. This is a two-wheel hand truck with special construction features and is made in a number of different sizes to suit various classes of work.

**MILLING MACHINES.**—Catalog No. 48, issued by the Newton Machine Tool Works, Philadelphia, Pa., is devoted to the subject of milling machines. This catalog is a book of 48 pages and thoroughly illustrates the various types of milling machines manufactured by this company. Descriptive matter is also included.

**AIR COMPRESSORS.**—Bulletin N from the Mesta Machine Company, Pittsburgh, Pa., deals with the air compressors and vacuum pumps manufactured by this company. The illustrations include reproductions of indicator cards taken from air compressors and also from cards taken from vacuum pumps equipped with Mesta plate valves.

**DRINKING WATER FOUNTAINS.**—A four-page leaflet issued by the Manufacturing Equipment & Engineering Company, Boston, Mass., includes illustrations and descriptive matter dealing with sanitary bubbling fountains. This company also manufactures individual sanitary wash bowls and reference is made to these in the leaflet.

**FORGING MACHINES.**—The National Machinery Company, Tiffin, Ohio, has recently issued National Forging Machine Talk No. 2, which is a folder dealing with the bed frame as a potent factor in the efficiency of the forging machine. Illustrations are included showing the steel bed frame casting for National heavy-pattern forging machines.

**BRASS FOUNDRY EQUIPMENT.**—Bulletin No. 31, from J. W. Paxson Company, 1021 North Delaware avenue, Philadelphia, is a 54-page booklet dealing with the brass foundry equipment furnished by that company. This includes furnaces, flasks, tongs, grinding and washing machines, etc., as well as a complete line of smaller equipment for brass foundry use.

**ELECTRIC LIGHTING FIXTURES.**—Bulletin No. 173 from the Dayton Manufacturing Company, Dayton, Ohio, deals with large unit lighting fixtures for electric railway cars. A number of different types are considered, including ceiling pendants, side brackets and ceiling fixtures, and considerable space is devoted to illustrating and describing the Flex shade holder.

**MACHINE GUARDS.**—A 34-page booklet issued by the Consolidated Expanded Metal Companies, Pittsburgh, Pa., is devoted almost entirely to the expanded metal guards for gear wheels and belts manufactured by these companies for preventing accidents on machine tools. The booklet contains very clear illustrations showing these guards applied to machines.

**SAFETY SWITCH PANEL.**—Bulletin No. 34 from H. Krantz Manufacturing Company, Brooklyn, N. Y., considers the safety panel manufactured by this company. Among the features claimed for this panel are that no live parts are exposed and all parts subject to wear are removable from the front of the board and can be replaced without adjustment. Illustrations and data for the different sizes and types are included.

**CASE HARDENING WITH GAS.**—A 26-page booklet issued by the American Gas Furnace Company, 24 John street, New York, describes an improvement in mechanical heating processes for case hardening work. It is claimed that by this process the surface of wrought iron or steel of low carbon may be converted into high carbon steel to any practical depth required for case hardening, at the same time leaving a core soft.

**GEARED SCREW JACKS.**—A catalog issued by the Cayuta Manufacturing Company, Thayer, Pa., illustrates and describes the standard ball and cone bearing geared screw jacks manufactured by this company. The catalog contains 24 pages and is well illustrated, among the jacks included being a high speed motor driven ball bearing screw jack. This jack is intended especially for quick work and is operated by an air motor.

**INDUSTRIAL AND CONTRACTORS' LOCOMOTIVES.**—Record No. 78 of the Baldwin Locomotive Works, Philadelphia, is devoted to the subject of locomotives for industrial and contractors' service. The locomotives included in this booklet vary from four wheel tank engines weighing 28,500 lb. to a Mikado with a total weight of 207,000 lb. Half tone illustrations are given and the leading dimensions of each locomotive are printed under the illustrations.

**THERMIT IN RAILROAD SHOPS.**—The Goldschmidt Thermit Company, 90 West street, New York, has issued a 52-page book containing instructions for the use of thermit in railroad shops. The subject is gone into in considerable detail and a number of tables as well as line drawings and half-tone illustrations are included. This book, which is known as pamphlet No. 21, second edition, will be found very useful in shops where thermit is used.

**ELECTRICAL APPARATUS.**—The Electric Controller & Manufacturing Company, Cleveland, Ohio, has issued an attractive booklet which contains an extract from a paper by H. F. Stratton in the December, 1913, issue of the Engineering Magazine, on the lifting of the Quebec bridge. With the exception of the motors, all of the electrical apparatus used in erecting the Quebec bridge is being designed and supplied by the Electric Controller & Manufacturing Company.

**CAR HEATING.**—The Gold Car Heating & Lighting Company, Whitehall building, New York, has issued a 44-page catalog dealing with the Gold electric car heating system. The details of the different heaters are illustrated very clearly, making the catalog of great assistance in ordering parts. One of the main features of the Gold electric heater, the ventilated porcelain core, is fully illustrated and described. This catalog also deals with the electric thermostatic control of steam heating which was described in the Railway Age Gazette, Mechanical Edition, for May. Several pages are also devoted to the Cyclone ventilator, which is also manufactured by the Gold Company.

# Railway Age Gazette

MECHANICAL EDITION

INCLUDING THE  
AMERICAN ENGINEER

PUBLISHED ON THE FIRST THURSDAY OF EVERY MONTH BY THE  
SIMMONS-BOARDMAN PUBLISHING COMPANY,  
WOOLWORTH BUILDING, NEW YORK, N. Y.

CHICAGO: Transportation Bldg. CLEVELAND: Citizen's Bldg.  
LONDON: Queen Anne's Chambers, Westminster.

EDWARD A. SIMMONS, *President* L. B. SHERMAN, *Vice-President*  
HENRY LEE, *Secretary*  
The address of the company is the address of the officers.

ROY V. WRIGHT, *Editor*

R. E. THAYER, *Associate Editor* C. B. PECK, *Associate Editor*  
A. C. LOUDON, *Associate Editor* GEORGE L. FOWLER, *Associate Editor*

Subscriptions, including the eight daily editions of the *Railway Age Gazette* published in June in connection with the annual conventions of the Master Car Builders' and American Railway Master Mechanics' Associations, payable in advance and postage free:

United States, Canada and Mexico.....	\$2.00 a year
Foreign Countries (excepting daily editions)....	3.00 a year
Single Copy .....	20 cents

Entered at the Post Office at New York, N. Y., as mail matter of the second class.

WE GUARANTEE, that of this issue 4,150 copies were printed; that of these 4,150 copies 3,654 were mailed to regular paid subscribers, 150 were provided for counter and news companies' sales, 267 were mailed to advertisers, exchanges and correspondents and 79 were provided for samples and office use; that the total copies printed this year to date were 34,300, an average of 4,287 copies a month.

VOLUME 88 AUGUST, 1914 NUMBER 8

## CONTENTS

### EDITORIALS:

Engine House Competition Prize Winner.....	393
Instructing Men on Safety Appliances.....	393
Mechanical Department Convention Reports.....	393
The Relations Between Foremen and Men.....	393
Tool Foremen's Convention.....	394
The College Man and the Railroads.....	394
Resourcefulness Needed in Engine House Work.....	394
Another Car Department Competition.....	395
The Draft Gear Problem.....	395
New Books .....	395

### COMMUNICATIONS:

College Men in Railroad Work .....	396
Questions for Car Designers.....	396
Packing for Superheater Locomotives.....	396
Melted Boiler Tubes.....	397

### GENERAL:

Study of an Internal Transverse Fissure in a Failed Axle.....	405
Distribution of Energy in a Locomotive and in Animals.....	414
Electric Locomotive Data .....	415

### CAR DEPARTMENT:

The Draft Gear and Its Solution.....	399
Pennsylvania Steel Box Car.....	419

### SHOP PRACTICE:

Tongs for Carrying Large Pipe.....	405
General Foremen's Convention.....	407
Combination Tool for Repairing E-T Distributing Valves.....	418
Tool Cabinet for Machine Shop.....	424
Tool Foremen's Association.....	425
Ball Bearing Column Crane.....	436

### NEW DEVICES:

Gas Producer Installation at the Juniata Shops.....	437
Planer for Locomotive Frames.....	438
Roundhouse Blower Valve .....	438
Driving Box Boring Mill.....	439
Turbine Boiler Tube Cleaner.....	440
Pilot Operated Valve for Hydraulic Presses.....	440
Pneumatic Rivet Set Retainer.....	441
Portable Electric Drill.....	441
Coal Passer for Locomotive Tenders.....	442

### NEWS DEPARTMENT:

Notes .....	443
Meetings and Conventions .....	444
Personals .....	445
New Shops .....	446
Supply Trade Notes .....	447
Catalogs .....	448

### Engine House Competition Prize Winner

The prize for the best article on engine house work submitted in the competition which closed July 15 has been awarded to R. G. Gilbride, locomotive foreman, Grand Trunk Pacific, Graham, Ont. A number of contributions were received in the competition and most of them have been accepted for publication. The judges considered that Mr. Gilbride's paper possessed the most merit from an all around engine house standpoint. The article will be published in the September issue.

### Instructing Men on Safety Appliances

It was brought out in the discussion on safety appliances at the Master Car Builders' convention in Atlantic City in June that considerable trouble has been experienced in getting men to understand the proper application of these devices. At one point on a large eastern road there has been little or no difficulty of this kind. It has been avoided by calling the foremen together and giving them careful instructions on the rules regarding safety appliances and their application to cars. At these times the foremen naturally brought up any questions which had proved puzzling to them and these were gone over by the entire staff and explained so that there was no further misunderstanding. The foremen, then having a thorough understanding of the appliances, made good use of this knowledge in instructing their subordinates. As a final precaution, each car that is equipped with safety appliances is carefully inspected by a committee of four foremen before it leaves the shop; errors made in the application are not likely to escape detection by some member of the inspection committee. This has proved to be the fact and almost no trouble has been realized in applying safety appliances at this shop.

### Mechanical Depart- ment Convention Reports

The Air Brake Association has established a record this year in placing the bound volume of the report of its 1914 convention in the hands of the members about two months after the association convened, and at the same time has included in this report the list of subjects and place of meeting for the 1915 convention. The association is to be congratulated on the despatch with which this work has been accomplished; it surely will be greatly appreciated by all the members. Every other similar association should make a strong effort to follow this example. The secretary of the Air Brake Association has been greatly assisted by a resolution passed by the executive committee to the effect that, if after three weeks from the time the remarks of the various members are sent to them for correction no reply has been received, the secretary be empowered to use the original remarks as reported by the stenographer in the final published volume of the proceedings. The Master Boiler Makers' Association, which held its annual meeting the latter part of May, has been equally as prompt in issuing its proceedings.

### The Relations Between Foremen and Men

In an address delivered before the International Railway General Foremen's Association, at the convention held in Chicago last month, A. P. Prendergast, superintendent of machinery of the Texas & Pacific, stated that he had always found a large proportion of railway employees prone to follow their leader. A foreman who does not conduct himself in a manner that will set a good example for the men under his jurisdiction need never expect to obtain a very great hold on their respect, and without it he will not be able to build up a very successful organization. It is not intended to suggest that a foreman should hold himself aloof from his men; on the contrary he should keep in close touch with them, not with the idea of looking for mistakes for which they should be censured, but in order to encourage them in their work and



to study their personalities. Much is to be gained in shop efficiency by assigning men to work which they like and for which they are especially fitted, and what branch of work this is can only be learned by close personal study of the individual. Any one who is engaged in a supervisory capacity should take pains to see that all reasonable steps are taken toward providing for the bodily comfort of the men. Not only is it due to the workmen to make their working conditions as pleasant as possible, but it will be found to tend greatly toward increasing their efficiency and toward perfecting the organization. The railway officer who believes that the only way to get work out of men is to drive and ill treat them is hopelessly out of date and should have no place in any present day railway organization.

**Tool Foremen's Convention**

The tool foremen at their recent convention maintained their previous good record in regard to attendance and thoroughness of discussion. Considerable information was given to the association by the different members, the best points of which covered the use of spiral reamers, and milling machine practice. The spiral reamers, when properly made, have effected marked reductions in the cost of reamers and at the same time have provided satisfactory results. By their use carbon steel can be used where high speed steel was previously necessary, and the workmen are provided with tools that do the work with such despatch and accuracy that it is a pleasure to handle them. That milling machine work is in its infancy, especially in railroad shops, is a well known fact; the possibilities are almost unlimited. From the enthusiastic discussion on this subject by Mr. Kinsey of the Illinois Central, the tool foremen have received suggestions that should bear fruit during the coming year.

The railway tool foreman is perhaps the greatest efficiency expert in a railway's shop organization. He is in a position to save the road by whom he is employed considerable money by providing tools in such a condition that they will require the minimum amount of power and labor to operate them, by providing special tools that will decrease the time required to do the various jobs, and by so designing and tempering the tools that they will give a good amount of service. He is an important man in the shop and should be given every opportunity to keep in touch with the progress in the art of tool making.

**The College Man and the Railroads**

Once again the ever important subject of the college man and the railroads demands our attention; this time in the form of a communication which will be found on another page. In developing and fitting himself for a career, can the college man afford to think of the compensation which will accrue to him during the early years of his service on the railroad? Surely this should not be deserving of very much weight during the first four years after leaving college. During this time it is vitally important to establish a right foundation, and this can only be done by beginning at the bottom and getting into intimate touch with the rank and file and with the minor details of the work of the department which the young man intends to follow. Experience, and particularly experience in studying the human element and its handling, are the important things. The amount of compensation is relatively unimportant. The danger is not in advancing too slowly, but rather in being advanced too fast and thus missing an important part of the experience which is to be capitalized in the future.

Our contributor compares the compensation of a special apprentice on a railroad at the end of four years' service with that of engineers who have gone into other fields of work and suggests that it is one reason why college men leave railroad work. Is this a fair conclusion? Or if the men do leave railroad work for this cause, is it not a serious mistake on their part? What would the results be if a similar comparison were

made at the end of a period of ten years and proper allowance was made for the difference in the cost of living at the points where the men were located, the advantages to the railroad employee of free transportation and the greater variety of the work in this field? It is true that railroad work has its disadvantages. It is also true that railroad officers, and particularly those in the mechanical department, are not as well paid as they should be; many of the mechanical department officers and foremen are very much underpaid and are deserving of far better salaries than they are receiving; but this is also true in many instances of men who are engaged in other fields of engineering.

The college graduate, when he enters railroad service, is a rather one-sided proposition. He may have the theory of engineering down ever so fine, but he is lamentably weak in practical experience and in the understanding of the human element. It takes him years to broaden out and to secure a proper balance, and he cannot expect to receive very large financial returns for the first few years of his service. The wise professor will send his men forth fully impressed with their lack of these essential features and with the knowledge that several years of strenuous application and hard work will be necessary before the handicap can be overcome. This handicap is greater in these later years on those roads which have thoroughly installed modern apprenticeship systems and are closely following them up in order fully to utilize the splendid material which is developed by these methods.

**Resourcefulness Needed in Engine House Work**

A college graduate, who has held the position of engine house foreman, stated recently that it was quite a little time after his appointment to the position before he finally realized that fixed lines of procedure are not followed to any great extent in making running repairs to locomotives. His college training had not appreciably shown him the need for following any but previously tried practice; in fact he graduated with the idea pretty well fixed in his mind that most mechanical engineering work follows lines of procedure that have been carefully tried out and proven. Most of his shop work experience was gained in a repair shop of considerable size where he saw such work as the lining of guides, the lining of shoes and wedges, etc., carried out in much the same way on every engine that went through the shop. Consequently, when he was placed in charge of an engine house he was the cause of numerous engine delays and much heated correspondence before he awoke to the fact that back shop methods cannot always be followed in making running repairs.

It is unfortunate that some of our colleges do not make greater endeavors to develop resourcefulness in their students. The course being followed by the students of the transportation course at McGill University, Montreal, should tend, to a considerable extent, to accomplish this. This course has been very carefully developed under the direction of Professor H. O. Key, who is in charge of the transportation department, and is being carried out in conjunction with the Canadian railways. The general manager of the eastern lines of the Canadian Pacific has recently issued a circular prescribing the course which the transportation students are to follow in obtaining their practical experience. This extends over the vacation periods of the college course and also over a considerable period after graduation, and regardless of what branch of railroad work the student intends to follow, he is assigned for a certain length of time to work in each department. Thus it may be readily seen that any one who intends following the work of the mechanical department must have considerable knowledge of engine house conditions, as he is assigned not only to a certain amount of engine house work, but also to work in the operating department, both on the road and in the yard. This brings him in direct contact with the engine house and gives him an insight into engine house conditions from the operating stand-

point, something which should prove invaluable to him later if he is placed in charge of an engine house. An engine house foreman who has assisted the yardmaster and the trainmaster in making up trains and in getting them over the road will not be likely to employ any repair methods which will delay a locomotive longer than is necessary.

**Another Car  
Department  
Competition**

The draft gear competition, which we recently held, developed some splendid information which should prove of great value in solving this troublesome problem. Undoubtedly the difference between a good and a bad draft gear is very noticeable in keeping the entire car in better physical condition and in protecting the lading from damage, particularly in the case of house or box cars. Leaving the draft gear out of consideration, what in your opinion is the greatest defect in box cars and how can it be remedied? The Railway Age Gazette a year or two ago published a series of articles on defective box cars and damaged freight. Since that time a very considerable advance has been made in so improving box car design and construction, and in so maintaining the cars, that greater protection is afforded to the lading. In spite of all the efforts which have been made, however, the surface has only just been scratched and there is still a considerable field for constructive criticism along these lines. Then, too, comes the question of the cost of maintenance, the time out of service for repairs, the cost of hauling excess dead weight and features of this sort. With a view to focusing attention on these things and of developing a better understanding of the defects of box cars and the remedies which should be applied, we announce a competition to close October 15, 1914, on defective box cars and how the defects may be eliminated. A first prize of \$50 will be awarded for the best paper, outlining what in the opinion of the writer is the most important defect and giving suggestions as to how it may be overcome. The judges will base their decision on the practical value of the suggestions offered. Articles which are not awarded a prize, but which are accepted for publication, will be paid for at our regular space rates.

**The  
Draft Gear  
Problem**

Last month we published the first prize article and three others that were submitted in the competition which closed May 15. Four more contributions to this competition appear elsewhere in this issue. These articles very largely supplement those which appeared last month; there is little duplication. Among the four which are printed in this number are two which advocate the use of the spring gear. Mr. Pearce bases his conclusions on the service records of 888 cars which were repaired in the "home shops" during a period of 30 days. It is rather difficult to reconcile these figures with those which were presented by Mr. Fritts in his paper before the Central Railway Club last September and which were reproduced in our issue of October, 1913. In the absence of further information concerning the records cited in Mr. Pearce's article it is to be assumed that the difference in results may be due to a variation in the types of the friction draft gears used, or as to the methods of collecting the data. More exact information as to the detail methods of assembling these records and as to the types of friction draft gears used is needed to permit of a proper understanding being gained of the value of these statistics.

It is interesting to note that the two practical car men represented in this issue both advocate the appointment of committees to thoroughly investigate the subject from a practical standpoint. Mr. Hogsett emphatically urges the railroads of the South to get together and go to the bottom of the situation without fear or favor; this to be done by a committee having representatives from the various departments involved. It is to be hoped that his stirring appeal will be listened to and heeded. Mr. Bundy urges the appointment of a special committee of the

M. C. B. Association; this because the committee on coupler and draft gear, as at present constituted, is overloaded with the great problem of developing a standard coupler. It is to be noted also that one of the contributors again emphasizes the importance of the type of draft gear as concerns coupler repairs. More complete data on this phase of the question might greatly affect the decision of the association in adopting a standard coupler.

**NEW BOOKS**

*Master Boiler Makers' Proceedings.* Bound in paper. 167 pages, 6 in. by 9 in. Published by the association, Harry D. Vought, secretary, 95 Liberty street, New York. Price \$1.

This book contains the official proceedings of the eighth annual convention of the Master Boiler Makers' Association, which was held at the Hotel Walton, Philadelphia, May 25 to 28, 1914. It will be noticed from the dates that the matter of publishing the proceedings has been handled very promptly and credit is due those who have had it in hand.

*Cambria Steel Handbook.* Prepared and compiled by George E. Thackray, C.E., special engineer, Cambria Steel Company. Bound in leather. 513 pages, 4 1/4 in. by 6 3/4 in. Issued by the Cambria Steel Company, Johnstown, Pa.

This book is the 1914 edition of the structural steel handbook issued by the Cambria Steel Company and is too well known to require an extended review. This is the eleventh edition and contains most of the matter of the previous edition, which, however, has been revised to conform to present practice and considerable new matter has been added.

*Some Engineering Phases of Pittsburgh's Smoke Problem.* Bound in paper, 193 pages, 6 in. by 9 in. Illustrated. Published by the University of Pittsburgh, Pittsburgh, Pa.

This report was made with the view first of determining the conditions which exist in the Pittsburgh district and account for so much smoke there, and second to describe the methods of furnace construction and the existing mechanical devices, the employment of which aids materially in securing more perfect combustion of fuel and lessens the amount of smoke produced. The book contains a large number of half-tone illustrations which show very clearly in a comparative manner the conditions which exist in Pittsburgh because of smoke.

*Link Motions, Valve Gears and Valve Settings.* By Fred H. Colvin, associate editor, *American Machinist*. Third edition, revised and enlarged. Bound in paper. 101 pages, 4 in. by 6 in. Illustrated. Published by the Norman W. Henley Publishing Company, 132 Nassau street, New York. Price 50 cents.

This book has long been well known among mechanical men, and this revised edition will without doubt be greatly appreciated. It is written in a manner that makes it readily understood and considers the locomotive link motion, valve movements, the setting of slide valves and gives analyses by diagram. A chapter is devoted to modern practice showing what is being done in the matter of eccentric rod lengths, etc. The slip of the link block is also considered and a chapter on piston valves shows eight varieties of this type as well as valve bushings.

*Engineering Manual.* Published by the American Electric Railway Engineering Association, 29 West Thirty-ninth street, New York; enclosed in cloth binders. Pages 6 in. x 9 in. Illustrated. Price to non-members of the association, \$3. Binders, \$1 extra.

This publication is a compilation of the standards and recommendations adopted by the American Electric Railway Engineering Association and covers practically the entire field of electric railway engineering. The book is in loose leaf form and consists of 82 sections fully illustrated with diagrams and working drawings. The loose leaf form has been adopted in order that the standards and recommendations may keep pace with such changes as are made at the yearly conventions of the association. Separate sections may be obtained if desired.



## COMMUNICATIONS

### COLLEGE MEN IN RAILROAD WORK

NEW YORK, June 11, 1914.

TO THE EDITOR:

A few weeks ago 14 young men who graduated in 1910 from a leading eastern engineering college were seated in a restaurant in New York. The conversation turned to salaries, and each man submitted his salary. This was done in such a way that the man to whom any given salary applied did not become known. These men were not picked. They were merely classmates who were located in New York, and probably represented a variety of temperaments and degrees of ability, as well as lines of work. The minimum salary noted was \$1,200 per year, the maximum \$2,100, with an average of \$1,540 per year.

A man who has finished his special apprenticeship of four years would only now be receiving about \$1,000 per year; up to this time his salary would have been even less. His chances for advancement are hardly better than those of other young men. Perhaps this case illustrates one of the reasons why college men leave the railroads.

SPECIAL APPRENTICE.

### QUESTIONS FOR CAR DESIGNERS

BENSON, Neb., July 15, 1914.

TO THE EDITOR:

In regard to the query of W. R. N. in the May issue, relative to the proper method of computing the bending moment at the corners of an open door frame in the side of a car for given conditions of shearing forces, the statements made by R. N. Miller in the June issue that the nature and magnitude of bending moment depend upon the manner of load distribution; that there are two general types of car construction, a center girder and a side girder type; and that the side door frame in a side girder type must be designed to carry its share of the bending moment in the side girder, are true in themselves but contribute little toward an answer to the question of W. R. N. His statement that the bending moment to be resisted by the door frame does not depend upon the vertical shear and that the shear serves only as a criterion of the bending moment, is not true. The proposition intimated by W. R. N. that the moment of forces tending to deform a side door frame may be computed from the shearing forces acting across that frame is true, and, so far as the particular problem given by him is concerned, the statement by Mr. Miller that the data given are incomplete is also true, but Mr. Miller failed to indicate what additional data were needed to solve the problem.

The use of the expressions by W. R. N. of "a downward shear on the right hand side of the door opening" and "an upward shear on the left hand side" indicate some confusion in his mind as to just what is meant by a shear. The shear on any section of a material is that condition of stress, the result of which is a tendency to slide the material on one side of the section relative to the material on the other side. Shear implies the existence of two equal and opposite forces, and we might have either one of two kinds on a given vertical section. First, the force on the right side may be acting upward and that on the left side acting downward; second, the force on the right may be downward and on the left upward. To distinguish these two kinds of shear we may arbitrarily call the first positive and the second negative. When W. R. N. speaks of an upward shear at one point and a downward shear at another I assume that he means that one is a positive and the other a negative.

Now let us compute the bending moment in the corners of a side door frame when we have the shearing forces. In the first place the shear at any section of a beam or girder is found by taking the algebraic sum of the forces (loads and reactions)

acting on either side of the section. If in passing along a beam from one point to another there is a change in the shearing force there must be a change in loads between the two points, and if the shear remains constant there is no change of load. Suppose we have a door frame of width  $b$  between posts, and at a vertical section immediately to the right of the left hand post we have a positive shear  $S$ . Assume there is no load on the frame between door posts, then on the left of our assumed section there will be an upward force  $S$  which is carried upward by the left door post, and to carry our downward force  $S$  on the right side of the section we have nothing until we pass over to the right door post. For this condition we can say that the shear on any section between posts is  $S$ , and the moment tending to deform the door frame is  $M = b \times S$ . This moment tends to bend the frame at the corners.

Again suppose that between door posts there is a load  $P$  acting downward at a distance  $a$  from the left post. If the shear at the left post is  $S$  as before, at the right post it will be  $S - P$ . The bending moment to be carried by the corners of the door frame in this case will be  $M = Pa + b(S - P)$ . In the problem given by W. R. N. he has failed to give the location of the load, or loads, that cause the shear to change in passing from one post to the other.

For a condition of zero shear there are no distorting forces on the door frame and the bending moment of the side frame of the car at that point appears as simple tensile and compressive forces in the top and bottom members. C. H. FARIS.

### PACKING FOR SUPERHEATER LOCOMOTIVES

CHICAGO, June 13, 1914.

TO THE EDITOR:

Superheater locomotives do their best work when the engine crew knows that it is actually getting superheat, and the time is not far distant when every superheater locomotive will be equipped with a reliable pyrometer that will indicate to the engineman just how much superheat is being obtained. There is quite a difference in superheat obtained on different locomotives, even of the same class.

This brings us to the matter of a proper metallic packing, or, rather, a proper metal for metallic packing for superheaters. A packing metal that does good work on saturated steam locomotives will not answer on superheater engines. While the reverse may be true, it is not always economy to use a superheater packing metal for saturated engines. The tandem packing and equipment is what the writer would suggest as the most serviceable packing and equipment for use on superheated steam locomotives. The particular make or shape of packing, outside of being a very substantial body of metal, can in most cases be left to the will of whoever is in charge. The idea of the tandem packing is that better lubrication of the packing rings is obtained as the two sets retain some of the lubricant between them when the steam is shut off. The recommended practice is to use a copper-lead ring, or rings, in the first packing next to the cylinder, as this packing does most of the work, and is in the hottest place. A babbitt packing, preferably a metal containing approximately 80 per cent lead and 20 per cent antimony, should be used in the second set. This combination of metals is recommended on account of economy and also because of the fact that this combination will not wear the rods as fast as two copper-lead packings will. This combination has been and is being used very successfully where babbitt packing rings alone would not stand up. A curious condition found is the fact that many superheater locomotives are running with babbitt packings, many of them giving very good satisfaction. The writer is of the opinion, however, that where babbitt packing is giving satisfaction on a superheater locomotive they are not getting proper superheat, at least they are not getting the highest superheat possible, which, of course, is what the superheater is for.

Where single packings are used, on account of not having clearance enough to permit the use of tandem packings, the copper-lead packings will be found to be the best and the only ones that can be depended upon, and also in the end the most economical, even though the first cost is considerably higher. The use of a good swab and careful attention by the engineer to keep it well lubricated will make such a packing give a very good account of itself. It is also a pretty well established fact that engineers should leave the throttle cracked when drifting; for besides helping the packing it materially helps other conditions, such as the valves, etc., in keeping them better lubricated. In this connection, it might be pertinent to mention the fact that it will be a paying investment to keep close watch on vibrating cups, followers, springs, etc., in order that they will be in good condition at all times for a service that is very severe on packing at the best.

A. E. M.

### MELTED BOILER TUBES

[The following correspondence with the illustrations explains itself. We should be pleased to have any of our readers give the details of a similar experience, or to offer any other explanation of the phenomena than that found in the letter below.]

Mr. A. B. C.—

A consolidation locomotive was recently side-swiped in one of our yards and, on the next day, the following report was made:

"The running board, cab, brackets and main reservoir were torn off the left side, the guide yoke was bent and there were other minor damages; estimated cost \$125."

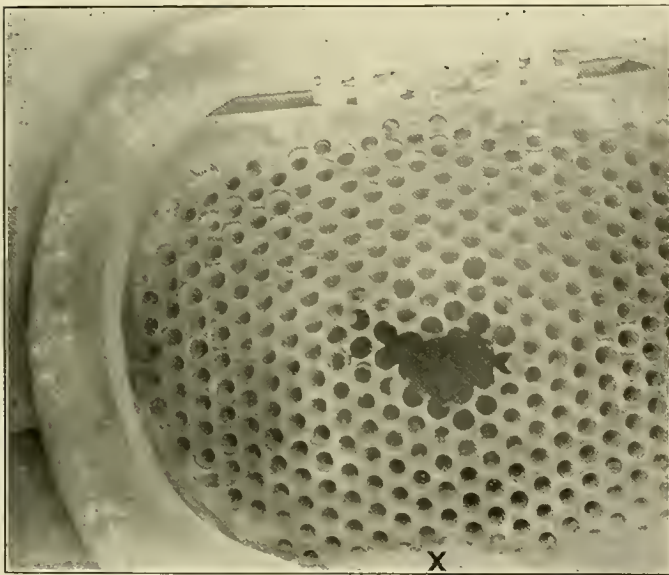

X is molten metal

Fig. 1—Condition of Front Tube Sheet, Steam Pipes, etc., Before Stripping

The information I have was that this happened about 12:30 a. m. It tore some of the studs out of the boiler that held the running board, which caused the loss of water and steam from the boiler. The fire was knocked out of the engine as quickly as possible, and the night roundhouse foreman was notified. He stated that he went to the yard about 2 o'clock and found the fire out, and instructed that the engine be brought to the roundhouse. It was brought to the roundhouse about 3:30 a. m. and set on the cinder pit, and one of the cinder pit laborers notified him that the headlight exploded. He went to the engine as quickly as possible and found the front red hot, which was the cause of headlight exploding; he took the little front off and found everything red hot in the front end. He sparked the front and took the arch out of the firebox, but this did not seem to

relieve the heat. He also put an iron plate over the top of the stack and left the firebox door open, thinking the engine would cool off.

About 6 o'clock in the morning he found the front end still very hot. There was no fire in the firebox nor ashpan, as the arch had been taken out, and there was nothing in the front end. As soon as the general foreman came on he called his attention to it, and as soon as the general foreman got to the engine he

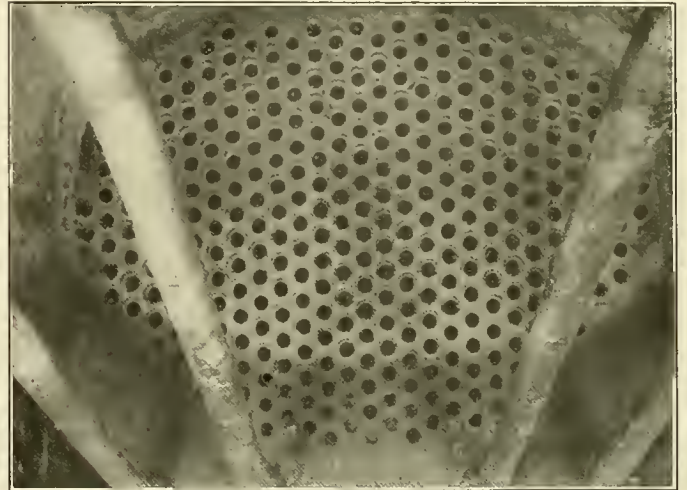

Fig. 2—The Back Tube Sheet and Arch Pipes Were in Good Condition

found the conditions as I have stated, but was afraid to put water in the front end.

I was called up about 8 o'clock and asked to come down to the roundhouse and look at the engine. I could not go down then, but went to the roundhouse at 12 o'clock noon, twelve hours after the accident happened, and found the flues still red hot; it had melted a part of the flue sheet and a great many of the

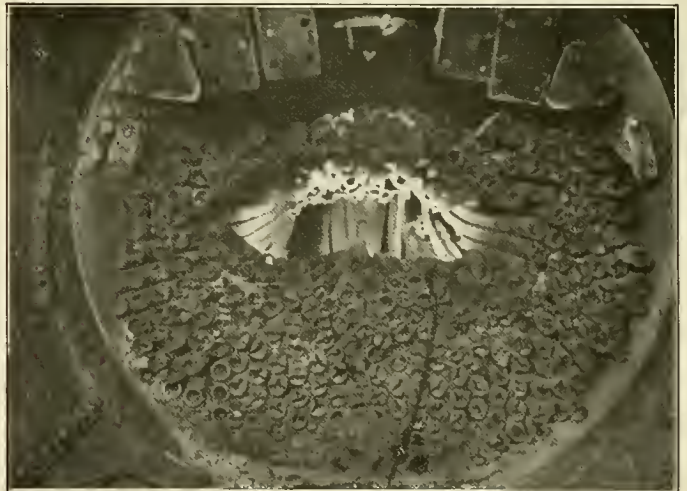

Fig. 3—View from Front After Front Tube Sheet Had Been Removed

flues entirely out, and the metal had run down in the front end and puddled. The total estimate of damage to the engine will be in the neighborhood of \$1,200.

This is a case that I have never seen anything like, and I am unable to explain what caused these conditions. This engine was sent to our shops for repairs and as the work of stripping the engine progressed we made photographs.

Our mechanical engineer and myself examined this engine and found that the greatest destruction wrought, due to overheating, was immediately back of the injector checks where a great num-



ber of the flues had been melted, as is clearly shown in Fig. 5.

Fig. 1 shows the front tube sheet, steam pipes, etc., before stripping. (The large hole shown in the center of the flue sheet was made so we could get some idea of what had happened inside the boiler and flues. Note the slag and melted steel from flues at X.)

Fig. 2 shows the back tube sheet and arch pipe, which were found in perfect condition. Fig. 3 shows the boiler from the front after the front tube sheet had been removed. Fig. 4 shows the interior of the boiler after the front tube sheet and all of the tubes had been removed. Fig. 5 shows the condition of the tubes just back of the injector checks. Fig. 6 shows a mass of tubes and solid matter taken from bottom of boiler just back of injector checks.

This is the second occurrence of this kind we have had in the past three years and we should be glad if you will tell us if you have ever heard of a case of this kind before and if you can say definitely what caused the damage.

X. Y. Z.,

Superintendent Motive Power.

Mr. X. Y. Z., S. M. P.

Perhaps the best way of answering your inquiry is to tell you of some other experiences.

A certain master mechanic had a lot of badly scaled locomotive boiler tubes. He had found that the scale was of such a nature

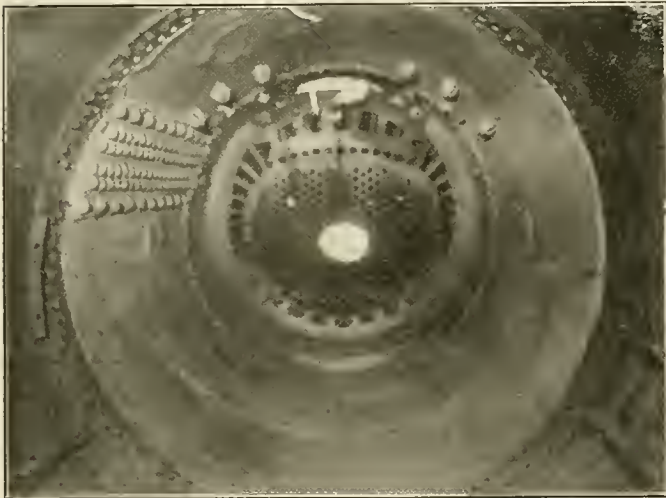

Bright Spot in Middle Is Open Fire Door

Fig. 4—Interior of Boiler After Front Tube Sheet and Tubes Had Been Removed

that it could be cleaned off by the application of heat, so he thought that he would make one grand job of it. He had them put in a pile and built a fire of oak ties beneath them. The fire was not hot enough to burn the tubes, but quite sufficient to remove the scale according to previous experiences.

He saw the fire lighted and went to his office; he had hardly taken his seat at his desk when a man rushed in and said that the tubes were melting. He went out and found that the fire was burning with ordinary brightness and not with any great intensity, but that, when he looked into the tubes, he looked into a glowing furnace at a white heat. The oak fire was pulled, but the tubes continued to glow and melt until they were quite destroyed.

The other case was that of a tug boat in New York harbor where the phenomena and conditions were very similar to those obtaining on your locomotive. The boiler had been emptied and the tubes were melted. The exact time required for the destructive action to take place I cannot give, but in all essentials it was a repetition of your experience.

Now for the explanation. There was a brick arch in the fire-box that was hot when the fire was pulled. All of the heat that it radiated, in cooling, was picked up by the air as it flowed gently into the tubes on its way to the stack. Of course, this air was heated to a high temperature and contained the usual

amount of free oxygen. There was possibly some soot or oxide of iron in the interior of the tubes, or some places where the tubes were quite bare. The high temperature of this oxygen enabled it to start an immediate attack on the exposed iron and set up a combustion of iron just as will occur in an oxygen bath. Of course, you are aware of the high temperature that would result from such a combination. But the products of the combustion of oxygen and iron are not gaseous as in the case of carbon and oxygen, but a solid, and so the heat generated by

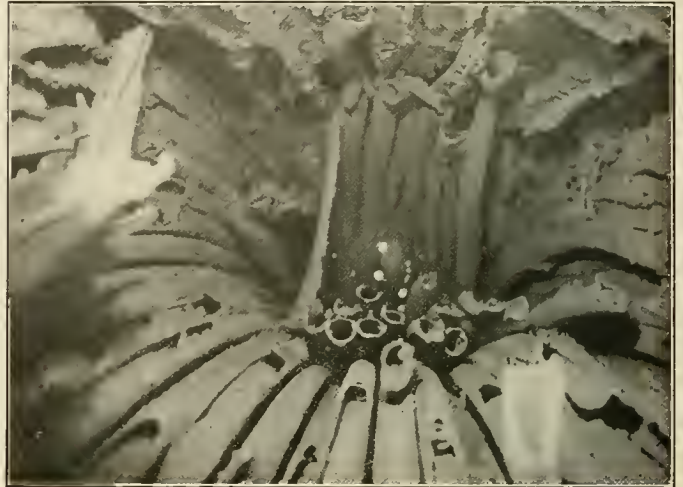

Fig. 5—Condition of Tubes Just Back of Injector Checks

the combustion was not lost by being carried away through the stack, but remained on the spot to add heat to that generated and the closing of the stack only made a bad matter worse by checking the draft and allowing only enough air to enter the tubes to keep up the fire.

I am inclined to think that this is an explanation of the phenomenon because the appearance of the tubes as they are shown in the photographs is so near like the appearance of the tubes of the first case cited that they could easily be passed off for the same. In that case there was no doubt of the oxygen-iron



Fig. 6—Mass of Tubes and Solid Matter Taken from Bottom of Boiler Just Back of Injector Checks

combustion as it could be seen to persist even after the original source of heat had been scattered. In the case of the tug boat the appearance of the melted tubes was that of tubes that had been melted by burning, and you will probably find this to be the case with the tubes of your locomotive.

Of course, the obvious remedy will be to break down the brick arch whenever the fire is pulled on an empty boiler. The tubes could not possibly ignite unless there had been a previous source of heat and this was probably started by the heat from the arch.

A. B. C.

# DRAFT GEAR PROBLEM AND ITS SOLUTION

Second Series\* of Articles on This Subject Which  
Were Contributed in the Recent Competition

## A SOLUTION OF THE DRAFT GEAR PROBLEM

BY J. W. HOGSETT

Chief Joint Inspector, Fort Worth, Tex.

How many different departments on a railroad are affected by the good or bad performance of the draft gear, and from what viewpoints?

### PURCHASING

The man in charge of purchases too often looks only at first cost, and if one device happens to cost ten or twelve dollars per car more than another the higher priced article is often turned down. At the same time he may have approved requisitions before him for a large number of couplers to be used in repairs. Unless his attention is called to it he would not associate the couplers purchased for repairs with the good or bad work of the draft gear. The purchasing officer should know that the draft gear offers its first relief to the coupler and its parts, as the shock is transmitted to the car through the coupler and the draft gear. If the gear is a good one the shock will not be as severe on either the car or coupler, hence fewer couplers will be needed in repairs. This applies to knuckles, knuckle pins, yokes, etc. Other requisitions may be on the purchasing officer's desk that could be reduced by the use of a good, instead of a bad draft gear; these include end sills, draft sills, siding and lining for replacing bursted ends, racked siding and roofing; even the life of metal roofs is dependent on the use of a good or bad draft gear.

If the executive officer, instead of commending the purchasing officer for saving five or ten dollars a car on the purchase of five or ten thousand cars, would look more to the purchases needed to keep the cars in service, better results would obtain. Of course the purchasing officer as a rule has no mechanical training, and it is hard for him to judge, but all roads have mechanical men that may be consulted, and by keeping a record of purchases needed to repair the cars it can very easily be decided whether the draft gear selected is good or bad.

### THE MECHANICAL SUPERINTENDENT

The mechanical superintendent is affected by the use of a good or bad draft gear from the fact that he is interested in getting the greatest mileage and longest life out of the cars at the lowest cost. He should look into the design of the different gears submitted for his consideration to make sure that they are built along good mechanical lines. He should also see that they are applied in such a manner that the inspectors may see when they need attention, and when they do need attention in the way of repairs the work should be done at once. If the draft gear is kept in good condition a reduction in the damage to other parts of the car is sure to follow. That's what the draft gear is for. It is like a pair of shoes—you go out on a rainy day with shoes having thin soles or a hole in them; the result is wet feet, colds, sometimes sore throat or other troubles that make you buy "Rock and Rye" or pay the doctor. Moral: Make shoe repairs before you get wet feet. It is the same in purchasing; one kind of a shoe will wear only a short time before giving one wet feet; others will wear three or four times as long, but will not cost three or four times as much.

The same is true of the draft gear. There is so much to be lost by the use of bad draft gear that the mechanical man should spare no time in looking into the merits of the various devices available. Above all, the gears should be tested under a heavy drop hammer to see if they are shock destroyers, and if they are

free from recoil. After they are in service, watch their performance; take them out occasionally and test them to see how long they will perform their work.

Get your superior officer to let you put on a few clerks to keep track of the total cost of car maintenance; not draft gear; breakages, because that is of no consequence. It is the other breakages that are causing your dollars to be wasted. Get to know something about the gears and car breakage—that's what mechanical men should do.

A few thousand dollars a year spent on clerks will give the mechanical superintendent information which will enable him to put his finger on the trouble spot and rub it out. With information of this character before him he is in position to administer the mechanical department economically, and the small amount spent on clerks will be nothing compared to the savings effected. If it does not show a saving then there is something else wrong. You may find that you have a man in charge of the mechanics that would make an excellent executive in some other line—a merchant, a farmer, a professor of science or some other walk in life. We are all good for something, but sometimes get misplaced.

### CLAIM AGENT

Does the claim agent know that it is possible to strike a car hard enough to turn over a case or barrel of breakable goods, even when securely blocked, destroying the contents? Does he know that a hard blow causes grain doors to spring, shift and break, allowing the grain to spill along the right of way, producing a beautiful crop in the spring which never matures into anything but a loss?

Did you ever have stock knocked off their feet resulting in claims for damage?

Did you ever see a car struck hard enough to knock the end out, and then run it through a storm, wetting everything inside?

Do you know that cars that are constantly being pounded will loosen and tear the metal roof or covering so that the rain runs through into the car and onto the contents?

Do you know water is not good for flour until you are ready to make the bread?

Do you know water is bad for cement until you are ready to make the concrete?

Do you know this is true with everything shipped in covered cars, and that is why such shipments are made in covered cars?

You do? Well, do you know one kind of a draft gear not only does not relieve the car of these shocks, but produces a greater number and very severe ones on account of the recoil. I am not going to spoil the effect of my article by telling you that there is a draft gear that is a cure-all, that will destroy the effects of all shocks, but there is a great difference in the amount of work one kind will do as compared to another. The difference is so great that there are thousands and thousands of dollars to be saved by getting the right one.

### THE GENERAL SUPERINTENDENT

Have you ever thought when looking over the morning business report, and finding that one of your most important passenger trains was delayed 30 minutes or more at some station on account of the freight train ahead breaking a knuckle, causing the train to part, and the shock due to the emergency application of brakes bursting the whole end of a weak car out, spilling the contents over the roadway, that if you had had a draft gear behind the coupler that would have lessened the shock on the knuckle, it would have prevented all this trouble?

This is a lot of trouble over a broken knuckle that only costs a couple of dollars, but can you give us the cost of the delay,

\*The prize article and three others were published in the July issue, page 361.



the damage to air hose, the bursted car end, the loss of lading? The knuckle was a very small part, yet it started the dollars rolling into the sewer. Why? Because the draft gear failed to do its work.

Have you ever while riding over the line in the observation end of your business car noticed the coupler, draft gear, draft arms and part of the draft sills, all intact, lying along the track with draft gear in perfect condition? Did you stop to think that the car was broken by shocks the draft gear failed to destroy and the end pulled out in transit? You get along a little further and find the car pushed in on some siding waiting for repairs. How long will it be before that car is ready for service again, and how much will it earn while waiting for repairs?

No doubt the draft gear salesman could have pointed out with pride that his gear was as good as new, but look at the car. The draft gear cannot haul freight unless it has a car with it.

Have you ever been in a congested yard trying to hurry the freight out, hustling everybody and everybody doing all they could to assist you, with the engine waiting to couple onto the train as soon as the last cut of cars are put on; just about that time the switchman, in his great desire to help and honestly feeling that he was a part of the big railroad, and doing his little bit to help, cut them off and they ran down with a crash that broke a coupler? How did you feel? Did you pray, whistle, sing or swear?

Now just one claim—if the draft gear had destroyed the shock, the shock could not have destroyed the coupler. Where is the expense of this little damage going to stop? Have you ever noticed that certain stations have 200, 300, 500, 600, 1,100 or more bad orders, and that they may be 4, 5, 6, 8, 10 or more per cent. of the total number of cars on the line? Have you heard the superintendent of transportation say that if such or such a shop could give a pull at noon and release 50 or more cars, he could supply the needs and save hauling empties from another division? Well, with all this before you, do you know that as much as  $\frac{3}{4}$  or 75 per cent. of your damaged cars are due to the shocks they receive? Do you know draft gear should destroy shocks, and not the cars?

There is a wide difference between the amount of work various draft gears will do. I am not going to tell you which one will do the most, although I have very decided views on the question. You can find out for yourself—then go to it. I'll say this much—you must look among the friction types to find anything like efficient gears.

We have in a limited way referred to four departments that should be interested in getting the best draft gear: The purchasing officer, general superintendent, mechanical superintendent and claim officer, and can find no advantage in having anything but the best device. There are, of course, other departments affected. The treasurer can turn over more money for betterments if he does not have to spend too much for repairs. The traffic department can make a better showing and keep its patrons, if claims for damaged lading are kept down, if trains are moved promptly and on time, and if the equipment is always ready. The greater the number of damaged cars on hand, the more the resources are curtailed.

Inefficient draft gear simply means broken cars and inefficient equipment. Inefficient equipment means inefficient service. Inefficient service generally means that somebody is looking for another job.

There is only one place or one set of men on a railroad really benefited by bad draft gear conditions, and they are the men who repair the cars. The more broken cars, the more work for the repair men, and we all need work to make us happy. The question is, however, could not a whole lot more good be done with the same amount of money? I have not given any statistics for the reason that I have none. I am working in the dark, but the leak is so great I see the need for more thorough investigation.

#### WHAT IS TO BE DONE?

The questions I have asked are put in a respectful way and are not intended to be sarcastic. I have no intention of offending. We are having lots of trouble, the exact cost of which could be shown by more attention to repair records. What I would like to see would be a committee of say seven men appointed to investigate this question for the southern railroads.

Their instructions should be to get all the information possible fearlessly. Confer with draft gear manufacturers; confer with southern railroads. Make public the results of such investigation no matter who liked or disliked it.

On account of the main features being mechanical the majority of the committee should be from the mechanical department. This committee should be selected from different roads in the south and be composed of the following men: general superintendent, superintendent motive power, mechanical engineer, master car builder or general car foreman, mechanical department clerk, purchasing agent, claim agent. There should be an odd number on the committee. It would make the committee larger, but two joint car inspectors would be a splendid addition.

There would be plenty of work for the nine men and we would surely know by the time the report was made something more about the question than is generally known now. It is knowledge we want and not guess work. Men of the South, get busy, let us lead instead of follow.

#### WHY ATTEMPT THE IMPOSSIBLE?

BY MILLARD F. COX

Thousands of draft gear devices have been introduced, patented and discarded. More patents have been taken out on car couplings and car coupling devices than any other single device known. To say that there are a great many good draft gears is to err as badly as to declare there is only one, or to intimate there is only one designer.

The new heavy wooden car looked well when it first appeared. It chuckled to itself in the belief that with its deep center sills, braces and ties it would withstand terrific blows, and deliver deadly thrusts to the less fortunately constructed. But time went on, and these thrusts were noticeably no less in their frequency and violence, nor less destructive in their delivery. Our new friend became old and the glory in which it once reveled departed. Frequent shoppings brought it into disrepute until our twentieth century armoured iron clad put in its appearance, when we hoisted the distress signal and bade our once highly respected "heavy wood" adieu. With the introduction of the modern all-steel car, draft gear geniuses obtained a new lease of life. The subject freshened up considerably, and the "now we have it" became a very familiar phrase to many of us. Our "dreadnaught," without the slightest ceremony began immediately to poke itself not only at but into our old friend the "heavy wood," until it was unbearable. The "heavy wood" hitched up its trusses, tightened up its straps, pulled down hard on its bolts, buckled on reinforcements, set its brakes, and defiantly bid its adversary "come on." One sudden jerk of the hand at the switcher throttle, aided and abetted by the "iron clad," hunched our old "heavy wood" fore and aft. She doubled and plunged like the Hesperus, except as to "leaping her cables length"—nothing short of such a performance could have saved her even temporarily. In the fatal plunge we caught sight of the draft gear disappearing amid the splinters of our old friend. It was only another case of the "survival of the fittest."

Modern draft gear designers have kept abreast of the situation very well, and have achieved notable progress; much credit is due them. In spite of the abuse that is heaped upon them, the good draft gears make as reasonable a showing as any of the other attachments made and designed to break when strained beyond their limit. Who would have a gear that would stand more punishment than the car it 'f? Who would agree to make a

gear stand indefinitely the ramming and jamming of the modern Mallet or Mikado locomotives and their loads of iron clads? There must of necessity be a breaking groove somewhere in our cars, as on our engines, or else the "tail will wag the dog." Draft gears which are designed to gradually absorb the shocks, with the fewest number of pieces, with some flexibility to all of their members, are more than apt to give a good account of themselves. They have already shown a reasonable amount of efficiency. Heedless, headless ramming cars into each other, especially in the hump yard terminals, is the most discouraging thing with which draft gear designers and car repairers have to do. The cars are all-steel and can't be broken—let's see—and away goes the 100 to 150-ton ram against the draft gear. The new heavy wood is just as good as ever, but it was not built for such service. It cannot buck successfully such a formidable array, nor cope with such conspirators as a Mallet engine, all-steel cars, a reckless train crew, and the hump yard method.

I have been asked how long a locomotive will last. It is no harder a question than "how much punishment can a draft gear stand?" The modern hump yard method is the last conspirator in the list, but it is by no means the least of them. Take a train of 85 cars which I saw a few days ago; allow 6 in. slack to each, and we get more than 42 ft. in the total. These trip hammer blows are delivered regularly with each start and stop with deadly effect. The real wonder is that the gear is not destroyed sooner than it is.

The best draft gear, in my opinion, is the one that absorbs consistently all the blows it receives in regular service, distributing such as it cannot take care of to the underframe with the least possible amount of damage. The efficiency of the gear depends largely on the design of the car, which makes them interdependent and inseparably correlated. A good strong gear under a weak car is perhaps better than if this condition were reversed. The net results will be that in the first case the car will go to pieces, and in the latter the gear must be constantly renewed. In the light of these very plain practical facts, which many of us will readily recognize, why not adopt a rugged gear of moderate first cost, giving due consideration to design and construction of both car and gear, keeping in mind that the very best that can possibly be done will not withstand indefinitely the punishment the rigging is subjected to. A well designed spring gear, with springs of vanadium heat treated steel, and all other parts of a corresponding high grade material—the best of their respective kinds—will give results as satisfactory as it is possible to obtain, notwithstanding the voluminous and conflicting evidence to the contrary.

**DRAFT GEAR PERFORMANCE**

BY E. S. PEARCE

It will be the purpose of this article to set forth the demands made upon the draft rigging of a car, the means employed to meet these demands and to what extent they have been successful.

FUNCTION OF A DRAFT GEAR

There are two functions of a draft gear: First, to facilitate starting a train by aiding in overcoming the inertia of each car in the train. Second, to dampen or absorb the shocks due to the irregularities in the track, change of grade and a change of speed, or a combination of the two, or all of the above.

*Inertia of the train.*—The action which takes place in a draft gear at the instant the train is starting, may best be understood by the following simple experiments: If a small spring balance is attached to the leg of a chair and the balance is pulled an action similar to the following will be noted. First, with a steady pull the spring will be distorted an amount equivalent to the force necessary to overcome the inertia of the chair; after the chair has started to move the distortion of the spring will be decreased to an amount equal to the force required to keep the chair in motion. Second, with the

force applied suddenly the spring will be distorted more quickly, and to a greater extent than with the steady pull. After the chair has started to move the action will be the same as in the first case. If, therefore, in starting a train, the starting force is quickly applied, a smaller initial rated tractive effort of the locomotive will be required than if the force is slowly applied. It is the purpose of the draft gear to assist in a sudden application of this starting force, and in so far as this particular function is concerned, the gear which absorbs the least amount of energy will prove to be the most efficient.

*Absorbing and Cushioning Shocks.*—Draft gears are called upon to absorb or dampen shocks which are received under the four following conditions of service:

1. Two cars meeting while running in the same direction at different velocities.
2. Two cars meeting while running in opposite directions, either at the same or different velocities.
3. One car meeting another car standing still.
4. One car with a given velocity meeting an immovable body.

Whether a car is being switched or is running in a train,

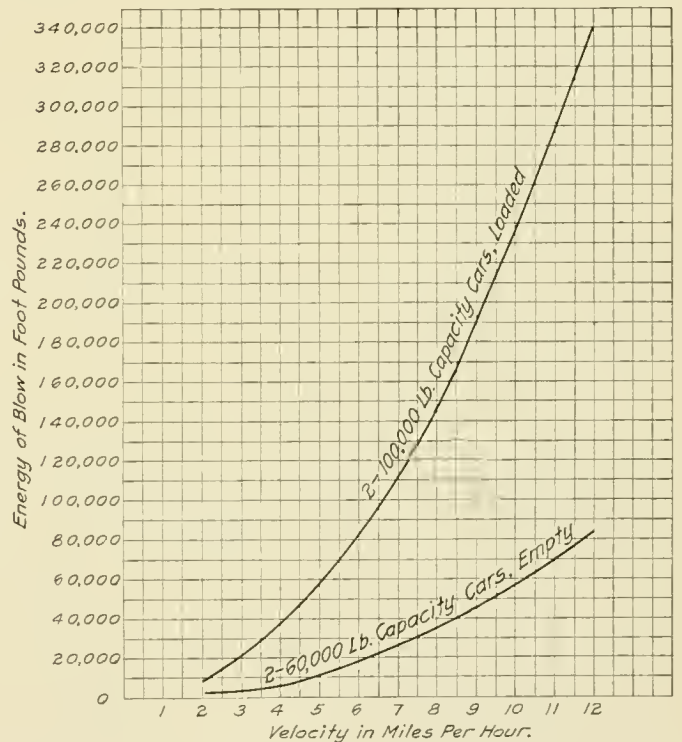

Fig. 1—Sum or Difference of Velocities for Conditions 1, 2 and 3

these four conditions will be met with. To obtain some idea of the magnitude of the blows delivered to a car subject to any one of these four conditions the curves in Figs. 1 and 2 are given. These show the blow delivered in foot pounds at various speeds, and were obtained by the use of the following formula as contained in the Proceedings of the American Railway Association of December 3, 1913, Appendix 5. The cars are considered as inelastic bodies and in the calculations a 100,000 lb. capacity steel car was assumed to weigh 43,000 lb. and a 60,000 lb. capacity car 35,000 lb.

Case 1. Two cars moving in same direction.

$$E = \frac{W \times W_1 (V - V_1)^2}{29.95 (W + W_1)}$$

In which

- W = Weight of one car in pounds.
- V = Velocity of one car in miles per hour.
- W<sub>1</sub> = Weight of other car.
- V<sub>1</sub> = Velocity of other car in miles per hour.
- E = Energy of impact in foot pounds.



The energy of the blow delivered by two loaded 100,000 lb. capacity cars whose velocities differ by 2, 4, 6, 8, 10 and 12 miles are plotted as representing the maximum blows for these speeds; the energy of the blow for two empty 60,000 lb. capacity cars for the same difference in velocities is plotted to represent the minimum blows for the same speeds; these are shown in Fig. 1.

Case 2. Cars moving toward one another.

$$E = \frac{W \times W_1 (V + V_1)^2}{29.95 (W + W_1)}$$

The curves for Case 1 represent this condition with the exception that here the velocities plotted are the sum of the velocities of the two cars.

Case 3. One car standing still.

$$E = \frac{W \times W_1 \times V_1^2}{29.95 (W + W_1)}$$

Fig. 1 will also represent this condition, the velocity here being the velocity of the moving car.

Case 4. One car striking an immovable body.

$$E = .0334 \times W \times V^2$$

Fig. 2 shows the energy of the blow received by a 100,000 lb. capacity car, loaded and empty, also that of a 60,000 lb. capacity car loaded and empty, when striking an immovable body at speeds up to 12 miles an hour.

It will be seen from these diagrams that a maximum blow of from 80,000 to 340,000 foot pounds may be delivered to the

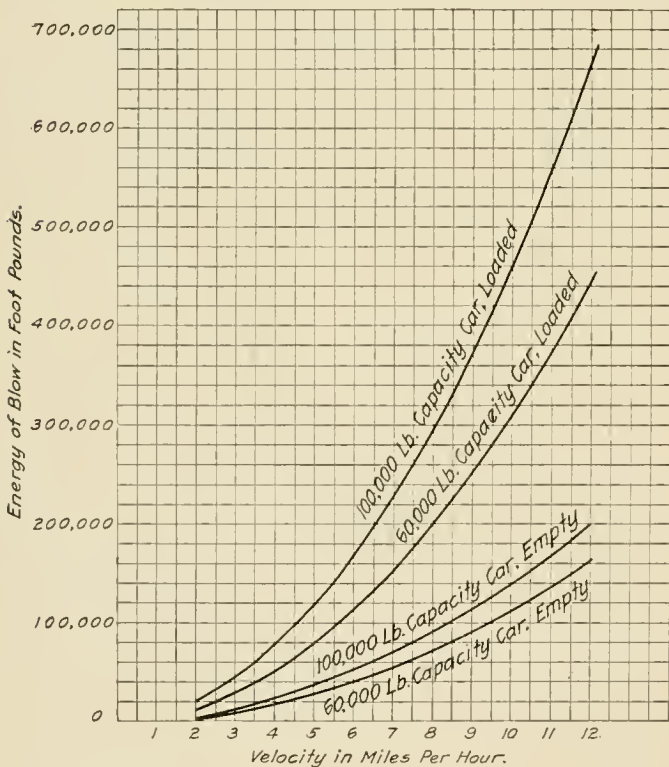

Fig. 2—Energy of Blow When Cars Strike an Immovable Body

draft rigging of a 60,000 to 100,000 lb. capacity freight car of all-steel construction under conditions met with in ordinary daily service.

TYPES OF DRAFT GEARS

There are on the market today two principal types of draft gears, and a third one which may be considered a combination of the two, namely:

(1) Spring gears, which, as the name implies, are springs which cushion the shocks.

(2) Friction gears which are dependent on the principle of the resistance to motion offered by two surfaces under pressure. The two surfaces are usually of like substances

pressed together by stiff springs. Gears of this type, unlike the spring gear, tend to absorb the energy of the blows delivered to them.

(3) Friction spring gears, or gears which absorb the blows delivered to them by the friction of their integral parts, which at the same time are distorted, producing the cushioning effect of the spring gear. Gears of this type are few and are generally considered as spring gears.

Of these three types the spring gear is the oldest, the second and third types being late developments, designed to meet the increased heavy demands of service. The action of these three types of gears will be best understood by an analysis of Fig. 3. In a static testing machine a friction gear gave the load curve which is shown. On applying the load, 105,000

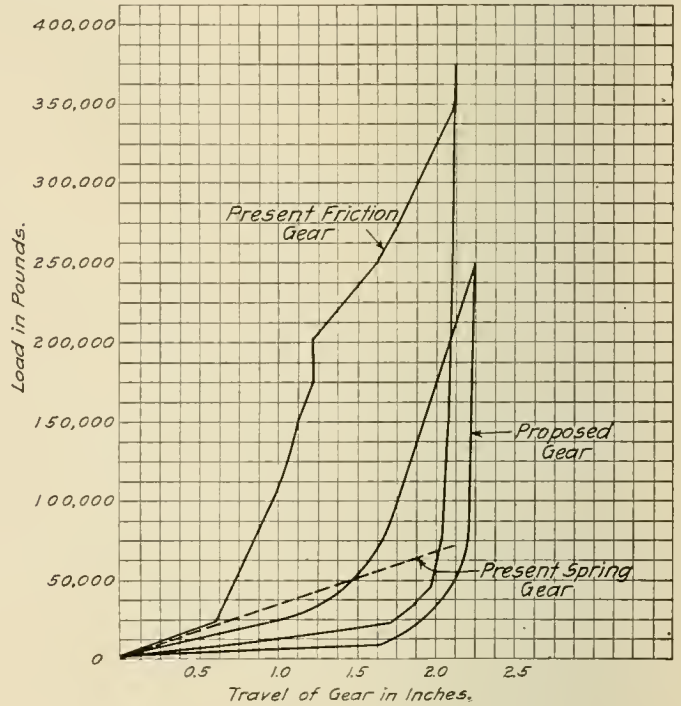

Fig. 3—Static Tests of Different Types of Draft Gears

lb. was required to compress the gear one inch, while the next half inch required an increase of practically 125,000 lb. On releasing, before the gear would move one-eighth of an inch, the load had to be reduced 325,000 lb. The spring gear, on the other hand, had an equal distortion for each increment of load and as the load was released the spring increased its length a corresponding amount. This in short represents the absorbing action, so to speak, of the friction gear and the cushioning action of the spring gear.

Another type of gear tested gave a diagram similar to that marked "proposed gear" and will be referred to later.

Certain tests made by a manufacturer of draft gears showed that his particular gear went solid under the blow of a 9,000 lb. hammer falling 28.4 in., which would be equivalent to a blow of 21,280 foot pounds. Two class "G" springs went solid under a 10 in. drop of a 9,000 lb. hammer, which is the equivalent of 7,500 foot pounds; the first gear had a travel of 3½ in. and the second gear a travel of 2½ in. The blow in the first case was delivered at a velocity of approximately 8.3 miles an hour while in the second case the blow was delivered at a velocity of practically 5 miles an hour. These represent the maximum of several tests which were accessible to the writer.

It will thus be seen that the present draft gears are probably driven solid quite frequently and that the car is called upon to bear the major part of many of the shocks, whether equipped with spring or friction gears.

DRAFT GEAR TESTS

In view of what has just been said in connection with tests of draft gears a brief statement concerning the present methods of testing them may not be out of place. There are several laboratory methods now used for testing draft gears, none of which may be considered as entirely satisfactory. This is due to the fact that the present tests do not represent actual conditions, and the results which are obtained are merely comparative for the various makes of gears under each particular set of tests.

The drop test, which is most used, while it measures the foot pounds of energy which will be required to make a friction or spring gear go solid, does not determine the ability of the gear to restore itself to its normal condition. The blows are delivered after the gear has restored itself to its normal condition, due to the load being entirely released. The time element in absorbing the blow is never touched upon.

The static load test, the results of which are illustrated in Fig. 3, does not apply nor release the load suddenly. Makers

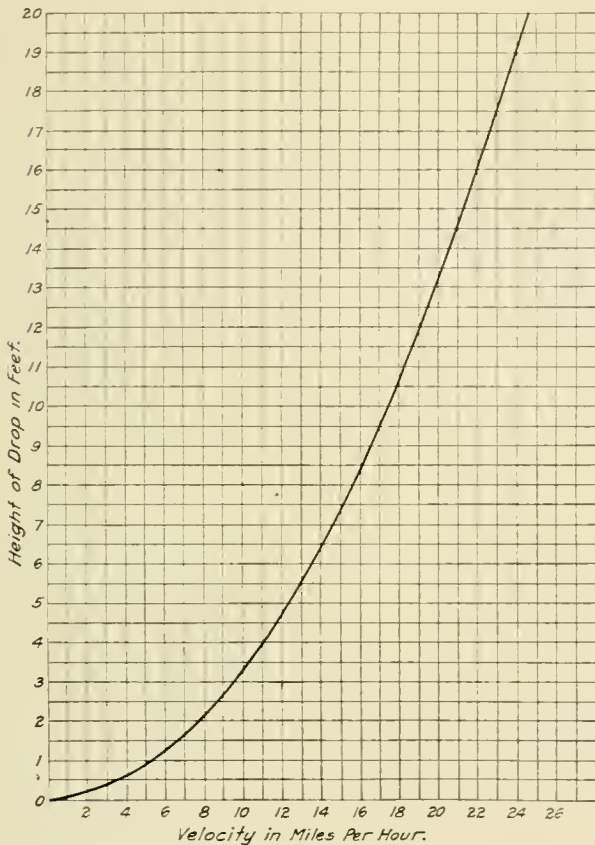

Fig. 4—Height of Drops to Give the Same Velocities as a Car Moving at Different Speeds

of the friction gears claim the diagrams mentioned represent the energy absorbing capacity of the gears giving such diagrams, but it is doubtful if this may be considered any criterion upon which to judge the fitness of a gear for service. The fact remains that gears which have made a wonderful showing during laboratory tests have fallen down in service within a comparatively short time.

The frequency and velocities at which the blows are delivered and the length of time that the gear is held in each particular position are the most important factors in the performance of a draft gear. There are no provisions in the present methods of testing for determining any of these factors, with the possible exception of the practice of placing a gear in a bulldozer and releasing and applying a load until failure of some part of the gear occurs.

The curve in Fig. 4 is given to show the height of the drop

in feet required to deliver a blow at the same velocity as a car moving at a rate of from 1 to 24 miles an hour. It must be borne in mind when considering the results of drop tests that a small weight, comparatively speaking, falling a long distance, may deliver a blow of the same total kinetic energy as a heavier weight falling a smaller distance, yet the larger weight falling a short distance will produce a greater deflection of the gear tested than the light weight falling a longer distance, due to the fact that the rate at which the energy of the blow must be absorbed or cushioned is greater for the small weight falling the greater distance.

There is little doubt but that the best method of determining the relative merits of a draft gear is by means of an actual service test, covering a large number of each particular make of gear on cars of various types.

SERVICE RECORDS

The following tabulation is taken from a service record covering a total of 888 cars which were repaired during a period of thirty days in home shops. The percentages are based upon the total number of cars in service equipped with each type of gear.

DISTRIBUTION OF FAILURES COVERING 100,000, 80,000 AND 60,000 LB. CAPACITY CARS OF ALL-STEEL, STEEL UNDERFRAME, OR CONTINUOUS STEEL DRAFT SILL CONSTRUCTION

1. Broken couplers .....	{ Friction .....	.193	per cent.
	{ Spring .....	.103	per cent.
2. Couplers pulled out.....	{ Friction .....	.0033	per cent.
	{ Spring .....	.009	per cent.
3. Followers broken .....	{ Friction .....	.018	per cent.
	{ Spring .....	.052	per cent.
4. Draft gear parts bent or broken.....	{ Friction .....	.5	per cent.
	{ Spring .....	.098	per cent.
5. Draft castings broken.....	{ Friction .....	.0184	per cent.
	{ Spring .....	.0087	per cent.
6. Sheared draft casting rivets.....	{ Friction .....	.00	per cent.
	{ Spring .....	.0062	per cent.
7. Sills bent or broken.....	{ Friction .....	.051	per cent.
	{ Spring .....	.042	per cent.
8. Pocket rivets broken.....	{ Friction .....	.063	per cent.
	{ Spring .....	.366	per cent.

CONCLUSIONS

The above tabulation seems to indicate that with the exception of broken pocket rivets, broken followers and couplers pulled out, the spring gears on the cars of all-steel, steel underframe or continuous steel draft sill construction are giving better service than the friction gears on the cars of the same construction. Couplers having the coupler yoke keyed on would not only obviate the failure of pocket rivets, but would also facilitate the work of repairing broken coupler parts necessitating the removal of the coupler.

By the practice of replacing wooden underframes with underframes of steel and the application of continuous steel draft sills, several railroads have accomplished a great deal in the way of reducing failures due to the draft rigging. The draft rigging on cars equipped with friction gears is more difficult to inspect and repair than on cars equipped with spring gears and for this reason there are in service today cars whose draft gears are of no use so far as performing their duties properly is concerned.

The fact that broken couplers and draft gear parts are the chief causes of failure with friction gear, seems to indicate that it is the blows of 100,000 lb. and less that do the damage. These are usually delivered so quickly that the friction gear of 300,000 lb. capacity has not the ability to absorb them, while the spring gear with a capacity of 60,000 lb. has the ability to cushion such shocks before they are thrown fully upon the parts which are most likely to fail.

Considering the present draft gear equipment upon the market it would seem most practical to build cars of sufficient underframe strength to take directly the blows of 200,000 lb. and upward and to equip them with gears capable of absorbing or cushioning the numerous small shocks up to 60,000 lb. and 250,000 lb., above which limit the elasticity of the car body would be called into play. This would mean



that the spring gear of the class "G" type or a friction gear such as that proposed in Fig. 3 would be most serviceable.

With the use of friction gears of smaller capacity, but more initial elasticity, it is reasonable to suppose that methods of construction may be devised which will obviate the present objectionable features of construction and maintenance and insure better service from the gear.

### BEST TYPE OF DRAFT GEAR FOR FREIGHT CARS

BY G. L. BUNDY

General Foreman, Delaware, Lackawanna & Western, Kingsland, N. J.

In your March issue you made the statement that one who has given the draft gear problem much study claims that inferior draft gears are costing the railroads of this country 250 million dollars a year in damage to equipment and congestion to traffic at terminals due to bad order cars. This seems high to me. However, it is a difficult problem and one has to take into consideration many other parts of the car that may fail, together with damage to lading and delays to traffic. We all know that inferior draft gears are responsible for many of the ills of the freight cars, and when we consider the great number of gears that have been designed, it shows conclusively that the trouble experienced has caused men to give much thought to the subject, hoping to bring out a design that would better meet the requirements.

With the increased weight and power of modern locomotives, double-head service, heavier trains, and heavier cars, the draft gear problem has forced itself more and more on our attention. Designs of gears that for some years gave entire satisfaction failed badly when heavier power and trains were introduced. The expense of maintenance of the draft gear has been on the increase and is a larger factor in the total cost of repairs to freight cars than it ever has been. In modern train service the shocks are beyond the capacity of any reasonable spring to absorb, and in case we had a draft spring with sufficient capacity to do this the recoil would cause many failures to couplers and other parts, and the damage resulting would make its use prohibitive. The draft gear must keep pace with the increased capacity of cars and heavier power and faster service. It has been demonstrated very thoroughly that the spring gear can not meet the present day service.

The draft gear on the freight car is the most important part of the car. There is little knowledge of the actual stresses to which the draft gears of freight cars are subjected to in actual service. In my opinion at least 70 per cent. of the damage to freight cars can be chargeable to buffing shocks, and it is these shocks that are causing most of the trouble. The prime requirement of an efficient draft gear is capacity for absorbing shocks, and at the same time it must be practically free from recoil. If we have a gear with sufficient capacity to withstand the shocks and relieve the underframe and superstructure, to a certain extent at least, of the many stresses they are subjected to, with sufficient flexibility between maximum and minimum because of its effect on the coupler, then we have an ideal gear and the best way to determine this is to test in actual service the different types of friction gears to determine to a certainty just what the gears will do.

I have come to the conclusion after a period of thirty years' continuous service building and repairing cars that there is a necessity for something better than the spring draft gear so commonly used. We should have a draft gear for freight cars capable of withstanding tensile stresses of 200,000 lb., and buffing shocks of 400,000 lb. Another most important thing to be considered is a means of taking up slack. Slack is bound to take place due to wear on the different parts and some means for taking up this lost motion must be provided, and in doing so the travel of the gear should not be reduced. The matter of slack in couplers or draft gears has never been given the attention it should, and cars are often allowed to run with from

2 to 6 in. of slack. This is bound to cause damage to other parts if it is allowed to continue.

The cost of maintenance of freight cars is on the increase and has been for a number of years. This is due to a number of reasons. First, inadequate draft gears; second, the rapid introduction of heavy power; third, frail construction; fourth, starting trains when it is necessary to take the slack a number of times. If all cars were equipped with a shock absorbing draft gear of sufficient capacity, much of the trouble and expense would be avoided.

The draft gear is receiving greater attention and a conclusive study would unquestionably cause us to recommend the application of friction draft gears to old cars that are considered worth repairing. Not until this is done can we expect the cost of maintenance of freight cars to drop. Figures as to the relative cost of maintenance of the spring compared to the friction gear show a vast difference in favor of the friction gear. Notwithstanding this fact many roads are slow in the adoption of the friction gear and as a result are the losers in the greater cost of repairs to the cars. This is true not only of draft gear parts but such other parts as longitudinal sills, end sills, draft timbers, doors, roofs, and car ends, to say nothing of damage to lading and delays to traffic.

Observation covering a number of years in the shop and yard repairing cars indicates that draft gear failures are more common than failures of any other part of the car. Any one doubting this statement can become convinced of the truth by visiting a few repair shops and noting the repairs being made. An adequate friction draft gear will reduce the broken parts of couplers and other parts of the car body and help in a large measure to keep bad order cars to a minimum.

J. C. Fritts, master car builder of the Delaware, Lackawanna & Western, in a paper before the Central Railroad Club at its September, 1913, meeting, gave some valuable data on draft gear, covering a period of twenty-six weeks, showing the failures of draft gears together with coupler and knuckle failures. This showed the friction gears to be far superior to the spring gears, the percentage of failures being 17 per cent. against 81 per cent. It proved conclusively the superiority of the friction gear over the spring gear, and if Mr. Fritts had included other parts, such as draft timbers, end sills, and longitudinal sills, which no doubt were broken in many cases, due to the spring gear, the result would show a still greater percentage in favor of the friction gear.

To determine to a certainty the relative values of the different classes of draft gear, and also to give manufacturers of spring gears a chance to test their gears against the friction gears, I would suggest that the railroads appoint a committee of five good practical men representing all the roads, this committee to be independent of the Master Car Builders' Association and to be instructed to fit up a number of cars with the different types of gears and test them out in service under all conditions, the cost of this test to be borne jointly by all the roads represented. A test of this kind would mean the survival of the fittest and would furnish valuable information for the railroads; at present many roads are applying draft gears, knowing little of the actual work they will perform. We have lost much time on this important subject and the matter should be taken up and settled definitely as soon as possible. After this test has been made and the merits of the different gears are known, any new gears designed should be submitted to be tested and not be considered unless they were as good as or better than the ones passed on by the committee. The device of any manufacturer who declines to submit his gear in this test should be treated as a gear failing to meet the requirements and classed with those the committee would not recommend. The expense of making a test of this kind would be money well spent and the amount would not be sufficient to work a hardship on any of the railroads.

My reason for recommending a special committee is that the

members of the present standing committee of the Master Car Builders' Association are busy men who can not spare the time to do this work to which the committee should devote its entire time until it is finished; in my opinion the service test is the only sure way to get at the facts as they exist. A test of this kind would result in many gears now in use being discarded and this would prove to be a saving not only in failures to draft gears, but the railroads would not be compelled to carry the different parts in stock.

I know from personal experience that most repair yard foremen make a practice of going over all the scrap material that is picked up along the line and brought into the shops and taking out all the serviceable parts of draft gears, knowing they will come in handy in making repairs to foreign cars; many times this saves holding a car for sixty or more days for material ordered from the company owning the car. The discarding of many of the different gears would render this practice unnecessary, at least to as great extent as at present.

In considering the draft gear, I am afraid railroad officers are looking only at the first cost. If such is the case the small amount saved in first cost is soon spent in maintenance, to say nothing of the damage to other parts of the car and damage to lading and delays to traffic. The spring gear has failed to stand up and meet the present conditions. There are friction gears in use today that do stand the service, and if the railroads would adopt the friction gear I am satisfied much of the trouble with draft gear failures would be a thing of the past.

I have spent the greater part of my life in repairing cars, and have been in a position to judge as to which kind of gear gave the best results. In conclusion I would recommend the use of the friction draft gear for freight service and the testing in actual service of the different types of gears to determine the capacity for absorbing shocks, amount of recoil, and means of taking up slack.

### TONGS FOR CARRYING LARGE PIPE

BY W. H. WOLFGANG

In handling large pipe where no crane is available the tongs shown in the drawing are very convenient. When placed around the pipe, from two to four men can lift on each pair of tongs.

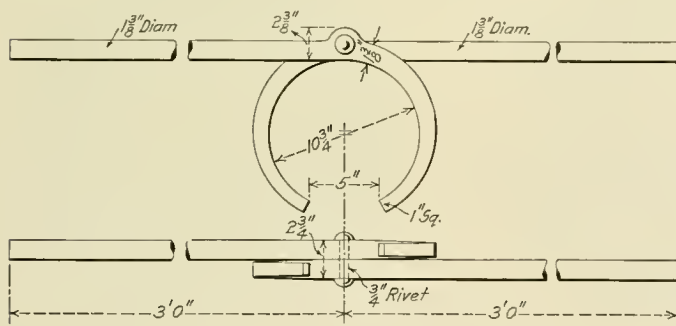

Handy Tongs for Carrying Large Sizes of Pipe

thus handling the pipe without difficulty. The tongs are made of wrought iron or open hearth steel and may be made in sizes to fit any diameter of pipe.

RAILWAY TIES IN NEW YORK STATE.—In New York's railways of over 8,000 miles practically all of the ties used in the tracks come from other states. Longleaf pine and oak are brought from the South and chestnut from the southern Appalachian mountains. These ties now cost the railroads from 65 to 80 cents apiece, whereas 15 years ago they could be purchased for from 35 to 50 cents apiece. Many railroads are planting trees to supply ties for the future.

### STUDY OF AN INTERNAL TRANSVERSE FISSURE IN A FAILED AXLE\*

BY ROBERT JOB

In view of the importance and the dangerous character of the type of failure known as "internal transverse fissure," we have taken especial interest in the study of a 10-in. driving axle which recently came under our observation. The axle in question was of plain carbon steel, annealed, and said to have had no subsequent heat treatment. It was received in a shipment direct from the manufacturers and upon receipt at the shops, while a cut was being removed in a lathe prior to mounting, it broke in two about 20 in. from the end. The appearance of the fracture is shown in Fig. 1. A band of bright, clean, unoxidized metal is seen around the circumference and extending about 1 in. toward the center. Inside of this band the surface of the metal was discolored and oxidized. This condition did not extend into the steel longitudinally, but was simply an oxidized transverse fissure which extended over the inner portion of the fractured area. The surface of the transverse crack was rough and irregular, and two longitudinal fissures were

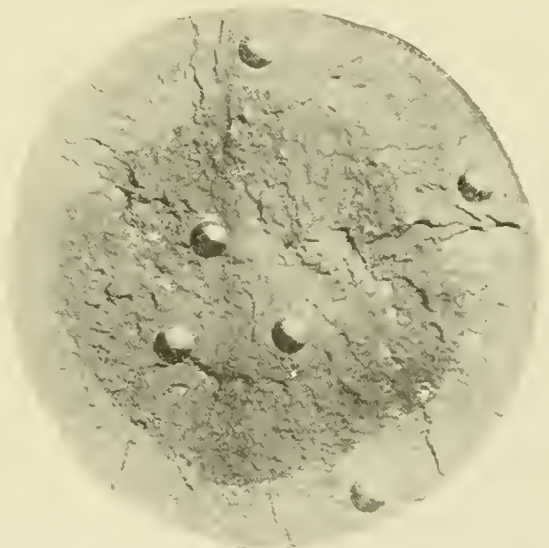

Fig. 1—Fractured Surface, Showing Oxidized Internal Transverse Fissure with Bright Metal Around the Outside

found, one across the center of the axle and the other about 1 1/2 in. from the circumference.

Three borings, from the inside and from the outside portions respectively, were taken for analysis. The analyses are as follows:

	Outside	Inside
Carbon, per cent.....	0.48	0.47
Phosphorus, per cent.....	0.022	0.019
Manganese, per cent.....	0.46	0.46
Sulphur, per cent.....	0.036	0.031
Silicon, per cent.....	0.142	0.161

The chemical composition, outside and inside, is closely alike and within the usual limits. It does not indicate the cause of failure, and the fact that the proportion of silicon is moderate indicates that no excessive amount of slag was present, although slag inclusions were found.

Test specimens were cut longitudinally from the axle, one from the bright outside portion close to the surface, and one from the oxidized portion about half way between center and circumference. The results of the tension tests are as follows:

	Outside	Inside
Tensile strength, lb. per sq. in.....	92,340	76,030
Elastic limit, lb. per sq. in.....	54,080	45,410
Elongation in 2 in., per cent.....	14.5	5.5
Reduction of area, per cent.....	29.6	12.3

In the outside portion it will be noted that the elongation and

\*Abstract of a paper presented before the American Society for Testing Materials, at the seventeenth annual meeting, June 30 to July 3, 1914.



the reduction of area of the metal are below normal, while in the inside portion the results indicate radically defective material.

Microscopic examination was made from sections cut from the above test specimens with results shown in Figs. 2 and 3, at 50 diameters. From these photomicrographs it will be noted that the size of grain in the outside portion of the axle was coarser than that in the inside portion, and that the size in the inside portion was fairly fine, indicating a proper annealing temperature at that point. A slag inclusion is shown in each of the photomicrographs.

We next cut a transverse section from the axle close to the point of fracture and on polishing and etching with iodine we obtained the result shown in Fig. 4. In this we found that one side of the axle—the upper part in the figure—was coarse-grained, while the center and lower part were of fine-grained structure with gradual coarsening near the surface. The steel throughout the section was rather porous and contained occasional small cavities and slag inclusions. Fig. 5 represents the condition at one of these locations, at 50 diameters.

The relatively coarser grain upon the outside surface around the entire circumference than inside proves that by the time the refining temperature had penetrated to the center of the axle, the steel upon the outside portion had been overheated, causing increased granular size, and resulting in a lower elongation and reduction of area than would have occurred otherwise. This condition simply means that the annealing temperature was not properly controlled; in other words, it is evidence of lack of careful mill practice.

The fact that the size of grain is decidedly larger upon one side of the axle than upon the other proves that the temperature upon the one side was decidedly higher than that upon the other. This condition could be produced by use of an unevenly heated annealing furnace, or it would also result provided the axles in the charge after annealing had been cooled unequally in any manner, as, for example, by opening the door of the furnace in the winter, and exposing the adjacent steel to the cold air. The same condition could also occur if a charge of axles was removed from the annealing furnace when at a red heat, and allowed to remain piled together with the outside

such condition would naturally result in weakness which would lessen the force necessary to produce fissures. The relative weakness and brittleness of the interior portion as shown by the tensile properties is fully accounted for by the evident lack of proper cropping at the mill and the intense strains to which the metal had been subjected.

#### DISCUSSION

It was maintained in the discussion that this particular fracture did not resemble the transverse fissures that are so common



Fig. 4—Transverse Section, 1 In. from the Fracture, Polished and Etched with Iodine

an occurrence in steel rails. It was not thought that this fracture could have occurred because of defective rolling or short cropping, but that it could have been caused by improper heating of the ingot before rolling. If the cold ingot were to have been

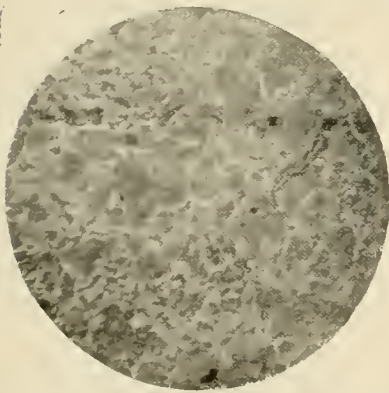

Fig. 2—Bright Outside Portion, About  $\frac{1}{2}$  In. from the Surface, Polished and Etched with Iodine; 50 Diameters

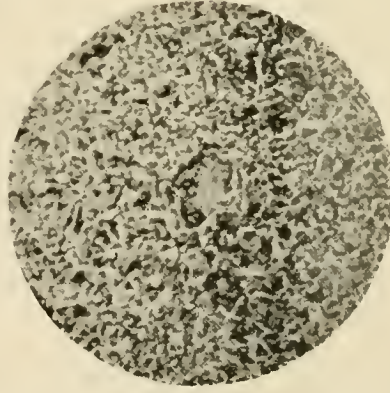

Fig. 3—Inside Oxidized Portion, Midway Between Center and Circumference, Polished and Etched with Iodine; 50 Diameters

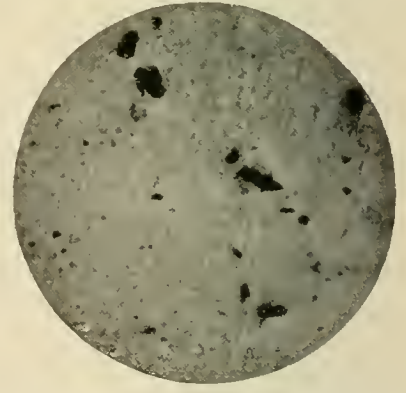

Fig. 5—Porous Steel. Section Near the Fracture; 50 Diameters

portion exposed to cold. The effect would be to chill the side of an axle exposed to water or to cold air, while the other side in contact with other red-hot axles might easily be maintained for a considerable time at a temperature above the critical point of the steel. Under these conditions, owing to the difference in relative rates of contraction, severe torsional strains would be induced which might easily cause rupture of the metal.

The fact that the steel was porous in spots and contained slag inclusions is an indication of insufficient cropping to get to sound metal—in other words, defective mill practice—and

placed in a hot furnace and the outside rapidly heated, it might have so expanded on the outside as to have put sufficient tensile stress on the interior to cause it to fracture and show a lense-shaped cavity like that described.

NEW ELECTRIC RAILWAY IN RUSSIA.—Plans have practically been completed for the construction of an electric railway from Riga to Asseru, a summer resort on the Gulf of Riga. The new line will be about 19 miles in length.

# GENERAL FOREMEN'S CONVENTION

## Including Papers on Engine House Efficiency, Air Brake Maintenance and Other Shop Problems

The tenth annual convention of the International Railway General Foremen's Association was held at the Hotel Sherman, Chicago, Ill., July 14-17 inclusive, W. W. Scott, general foreman of the Delaware, Lackawanna & Western at Buffalo, presiding. The opening prayer was offered by Rev. Peter J. O'Callaghan, and the association was welcomed to the city by Leon Hornstein on behalf of the mayor of Chicago. W. T. Gale of the Chicago & North Western responded to Mr. Hornstein's address. F. A. Delano, president of the Chicago, Indianapolis & Louisville, addressed the association at the opening session, taking as his subject "Scientific Management." Briefly, Mr. Delano mentioned the purpose and the meaning of scientific management, and pointed out that in the main it was a new application of old ideas. Whatever kind of management is to be followed it is necessary to have co-operation, which, in turn, is dependent on leadership, and that, in turn, requires organization. Mr. Delano made it plain that in order for a foreman to succeed he must carefully consider these three items.

### PRESIDENT SCOTT'S ADDRESS

Recent events have brought rather prominently to public view the question of efficiency and economy in railroad operation. As railroad officers, efficiency and economy has been our constant watchword. Publicity has not until recent years entered very largely into railroad operation and the public has often been led astray by not being correctly informed as to the methods of efficiency and economy practiced by the railways. Every published statement reflecting credit on the railways, whether relating to their good intentions or to their able management, strengthens them in the public esteem and tends to promote a wise and judicious solution of the problems of government regulation. There are none of us who wish to evade discussion of our efficiency. As far as the mechanical department is concerned, our efforts have not been sufficiently brought to the light of public recognition. This is one of the purposes of our association. Here the standard of efficiency and economy in the performance of every function incident to the manufacture and maintenance of the locomotive has been advanced by comparisons of experience. It is here we have our suggestions to offer for the betterment of our power. It is here that our companies reap the benefit of our experience, thought and labor. To that end, therefore, we should all participate in the discussion as freely as possible.

It is recommended that the subjects presented at this convention for discussion be retained for next year, except the two subsidiary papers, and also that the number of members on the committees be increased to ten and that they be selected from roads in different parts of the country in order that all the conditions due to climatic or other unusual conditions may be considered. On account of the close relationship between the general foremen and the Tool Foremen's Association, it is believed that if it is possible it would be much to the advantage of both associations to have them meet during the same week.

### ENGINE HOUSE EFFICIENCY

BY W. W. SMITH

Chicago & North Western, Chicago, Ill.

In the report on engine house efficiency presented last year, the different phases of the subject were treated in a general way. The subject was continued so that new material could be added.

*Engine Mileage.*—The operating department by co-operating with the mechanical department can do much to increase engine mileage.

Trains are oftentimes too long on the road due to poor train despatching or overloaded engines; engines are delayed to and from the train yards and the engine house; engines are delayed by yard forces not having trains made up; and oftentimes trains come in or are ordered out in bunches, so that the engine house organization cannot handle the engines in the manner they could if the trains had been properly spaced. In storing engines, those should be kept in service whose mileage comes nearest entitling them to a shopping. If poorer engines are stored, the good ones are being worn out during the dull season. There is undoubted economy in long runs for passenger engines, even though they are more conducive to engine failures. In order to make long runs a success, locomotives must receive very careful attention at engine houses.

*Pooled or Assigned Power.*—Whether it is best to pool power, or assign each engine to a regular crew, is a problem important to engine house efficiency. When an engine is assigned to a regular crew, it is given more attention by the crew, there is less apt to be delay in getting away from the engine house, failures are less apt to occur, and the cost of maintenance is sure to be less. A system of regular assigned engines has been inaugurated on some of the divisions of the Chicago & North Western, with very gratifying results. The runs are pooled—that is, regular engines are not assigned to certain runs, but an engine crew with a regular engine will take any run that their turn on the board entitles them to.

*Terminal Delay.*—The greater cost and earning power of recent locomotives makes it more necessary than ever to keep them in service. The question of turning engines promptly is one of system and supervision. In turning engines at terminals, the most valuable units of power should be given the preference. Also the ash-pit tracks should be arranged so that engines not requiring washing out, or other heavy work, can be run around those requiring washing out. Where a hot water fill-up line is provided, a considerable saving in time can be made by letting water out of the boiler and re-filling with fill-up water which is nearly at a boiling temperature. The engine house foreman should always be in a position to quickly and accurately advise the transportation department when he expects engines to be ready for service. Then a definite prospective figure should be given to the yardmaster two hours before the engine will be ready, from which figure the engine should be ordered.

*Engine Delays.*—At busy terminals, where important trains are despatched, whenever possible, an extra freight and an extra passenger engine should be fired and ready for service, so that in case of the unexpected happening, there will be an engine to fall back on. A running log book will tend to eliminate delays from the failure of either the day or night engine house foreman to notify the other concerning repairs that are left unfinished. It should be the duty of the turntable operator or his assistants to keep posted on the time that engines are ordered, and see that engines get out on time.

*Engine Failures.*—Each new failure should be carefully studied, as well as the past failures shown on the records. In this way it is possible to arrive at conclusions, and thus take action to prevent recurrences. Oftentimes some simple little contrivance will prevent costly failures. Enginemen should be required to report any unusual trouble or delays they have encountered on the road due to the engine or cars—even though a failure has not been charged by the transportation department. When there is any doubt as to the successful outcome of a trip, the road foreman should be called to ride the engine.

*Mileage Between Shoppings.*—It is probably best to compute



locomotive costs on a ton mile basis so there will be a tendency on the part of master mechanics and others to keep engines in 100 per cent. efficiency as long as possible, and then when it proves impracticable for the engine house to further maintain them at their full hauling capacity the engines should be shopped. As an average figure for all roads, freight locomotives do not make more than 40,000 miles between shoppings, and passenger engines not more than 80,000-100,000 miles. Ordinarily it is considered good practice to expend 60 per cent. of the maintenance costs in the engine house, to insure best road service, and 40 per cent in the shop.

Too frequently the shop and engine house do not work in harmony. There are many things, while an engine is stripped down in the back shop, that can be done for about one-third the expense they could be done for, four or five months afterwards.

*Economy in the Engine House.*—The intelligent ordering and use of material, careful watch on store house supplies, close attention to fuel consumption, etc., are factors that must be watched. There are unlimited possibilities for saving fuel at the engine house. Cylinder and valves blowing, cylinder cocks and relief valves that do not seat, leaky whistle and pop valves, leaky boilers, steam leaks in the cab, improperly drafted front ends, bushed nozzles, etc., are all sources of waste that are caused by imperfect maintenance. Then there are direct losses of fuel at engine house, due to tanks being overloaded, to uneconomical methods of firing up engines, to engines popping off on cinder pit track while waiting to have fire cleaned, to engines fired too long before they are ordered, etc.

Each engineman should have an individual tool box, which, together with the oil cans, should be removed from the engine at the end of the trip by the supplyman. Engine cushions should be securely fastened to the seats, and suitable boxes or racks should be provided in the cab, for lanterns, emergency signals, etc. In order that each fireman may have his own shovel, a suitable rack should be placed in the engine house to which shovels may be chained and locked.

*Handling of Switch Engines.*—When switch engines are delayed at the engine house, or are so poorly maintained that they cannot do effective work, the train service is correspondingly impaired. The engine house should make every effort to furnish switching power on time. As an aid in doing this, the work at the cinder pit should be very closely supervised at noon and at midnight, when a number of engines are in at the same time to have fires cleaned. Switch engines should be held in for inspection and repairs at stated intervals. On several roads, at important terminals, a system of relief engines has been adopted. With this plan a relief crew is engaged in taking engines to and from the engine house and yard, and the regular yard engine crews do not come to engine house with engines.

*Organization.*—The subject was considered in some detail in last year's report. In most engine houses it is advisable to have at least one engine held in for repairs so that the amount of work can be balanced. Thus when running repairs are heavy the men can be borrowed from the laid-in work, and when running repairs are light they can be shifted to the heavy work. As far as possible vacancies should be filled from men in the ranks, and the vacancies in the day force should be filled from men in the night gang. When workmen know that good service will be rewarded by promotion, it is an incentive for them to do good work and stay in the service.

*Co-operation.*—The fundamental principle involved in getting good engine house service is the individual interest of every employee concerned, and the co-operation of all. Probably no other one thing can do quite as much to reduce the net earnings as friction or ill will between the operating and mechanical departments. The closer officials of the two departments get together, the better will be the results. The master mechanic or foreman should call up the train despatcher the

first thing in the morning, and help him to line up things, thereby heading off probable failures, and in return receiving valuable information for his department.

A friendly spirit of co-operation should exist between master mechanics and foremen of different divisions. It often happens that engines from one division run into the terminal of another division, and unless there is harmony between the men of the two divisions the best interests of the company must be sacrificed.

*Terminal Facilities.*—The basis of efficiency of a locomotive terminal is time, and everything should be arranged with this idea in view. To obtain the best results in saving time between the yard and the turntable, the engine house should be as near as possible to the yards, and connected up with suitable tracks so that the necessary running back and forth can be done independent of the main line; also there should be separate tracks used for incoming and outgoing engines. The cinder pit is the critical point in the locomotive terminal, and this is especially true during severe winter weather. It should be located as close as possible to the turntable, and large enough so that a sufficient number of engines can be handled at the same time.

The engine house should be long enough so that all engines can be housed, and with some room front and back and at the sides so that the work will be facilitated as much as possible. It often becomes necessary to move engines in order to make repairs to rods, etc., and if the rails are extended beyond the front end of pits, the engine can be moved ahead instead of back; thus making it unnecessary to have doors open in winter time. Pit drainage is also a very important factor. Good natural lighting is one of the most important features leading to a high efficiency in engine house work.

A hot water washing and filling system is almost a necessity in any important engine house. Not only is there a considerable saving in the time that engines are held out of service for boiler washing with this system, but there is the added advantage of increasing the life and improving the condition of the boilers themselves. A blowing down line should be included in the system, and it should have a capacity sufficient to empty a boiler with 180 lb. pressure in not more than 30 minutes. Washout water should be provided for washing out with a pressure of at least 100 lb., and at a temperature of about 150 deg. Then the filling up line should furnish water at a temperature of about 190 deg.

The drop pit section of the house should be from 100 to 112 ft. long, so that engines can be spotted in any position with the doors closed. In engine houses where it is the custom to make fairly heavy repairs, a drop pit should be provided for dropping the entire engine truck in the pit, so that repairs can be made to male casting, cylinder frame bolts, etc.

There should be a vise bench at every other stall. Some consider the location against the outside wall as preferable to between the stalls on the posts, the reason being that in the former position more room is available to work on engines.

Inspection pits placed on the incoming tracks should be shallow and simply deep enough to enable a man to examine all parts underneath. These pits certainly facilitate the movement of engines in busy times. It often happens that an engine on reaching this pit will be found on inspection to have but a few nuts loose here and there or is in need of some slight repairs that can be made on the pit. The engine then passes through its different operations, goes on the table to be turned and is ready for a return trip. This saves putting the engine in the house at all.

*Locomotive Maintenance.*—Locomotive maintenance costs continue to rise, but when we make allowance for the increase in wages, the increased cost of material, and the added complexity of the modern locomotive, the cost of repairs per unit of work has been actually decreased. All important engine houses should be furnished with an ample supply of spare parts, such as air

pumps, lubricators, injectors, bell ringers, etc., which should be used to replace defective apparatus, whenever it will take less time to exchange than to repair.

*Running Repairs.*—The heavy labor cost that attends the removal of driving wheels in the ordinary engine house requires that most of the running repairs to locomotives must be made without removing the drivers. Driving boxes cannot always be taken care of in the engine house, but the careful maintenance of the wedges will do much to keep the driving box brasses and the rods in good shape. In order that driving box brasses may be maintained in the engine house, and without the necessity of dropping drivers, driving boxes with removable brasses have been adopted as standard by the Chicago & North Western. In order to lighten the maintenance costs of shoes and wedges several roads have adopted a flangeless shoe and wedge; also a new design of driving box which has part of the inside back flange removed, so that wedges can be lined down without taking down the pedestal binder.

Lateral motion in drivers, trailer and engine truck wheels is one of the hardest problems to contend with in the maintenance of locomotives. In order that end play may be taken up in the engine house without dropping the wheels, and without holding engines from their runs a box has recently been introduced with removable lateral motion plates with babbitted faces. These removable plates can be used on engine and trailer truck boxes, as well as on driving boxes. They have been adopted as standard on several roads. As an aid in taking up lateral in engine trucks, it is the custom on some roads to babbitt both sides of engine truck boxes when engines are undergoing repairs, so that in the engine house it is only necessary to turn the boxes end for end to take up the lateral.

With the marked increase of weight and power of locomotives, the tire mileage has decreased, but by use of improved heat treated and vanadium steel tires, the mileage has been increased in some cases. Vanadium steel tires should be expected to give nearly twice greater mileage than the ordinary carbon steel tires. Tread wear can be lessened to some extent by keeping sanders in good order, and seeing that the steam distribution is equal, so there will be no unnecessary slipping of drivers. Tires are sometimes flattened by a poorly maintained driver brake. In order to prolong the life of tires, they should be changed or turned before the flange wear is excessive; otherwise an undue amount of stock must be turned on the tread to get a full flange. For the same reason steel or steel tired engine truck or tank wheels should be changed before the flanges become sharp. The retaining rings reduce the liability of failure from loose tires, but they make it very inconvenient to change or shim tires, and hence increase the cost of maintenance. From an operating standpoint a lip on the tire is almost as good as a retaining ring.

When driving boxes and wedges are well maintained very little trouble is experienced with rods. In order to lighten the maintenance of main rods, two designs of solid end main rods have been recently introduced. With both types straps and bolts are eliminated—only wedges and filling blocks being used in connection with the brass. The Foulder design uses the same pattern of brass both at front and back of the pin, while in the Markel rod the brass is cast in steel blocks. The former has to be removed from the pin when it is dismantled, but the latter can be dismantled on the pin.

Sand plays a very important part in the performance of locomotives, both from the standpoint of fuel economy and of handling tonnage, so that it is imperative that engines leave terminals with sanders in good working condition. The quality, the drying and cleaning of the sand, must be given careful attention. The secret of getting good service from sanders is the careful attention given to the piping. Fifty per cent of the sand failures are due to split and loose pipes not pointing to the rail.

With the engines now in use, injectors are often required to supply as much as 150 gal. of water per minute, when engines

are operating at full capacity. Hence the need of maintaining tank valves and siphons, feed and delivery pipes, injectors and boiler checks, in good condition. In order that coal which accidentally falls down the tank manhole, cannot work ahead to the tank valves or siphons, it is the practice on several roads to extend a splash plate across the tank in front of the manhole, and cover the opening at the bottom with screening.

All piping should be securely stayed and clamped, otherwise it is impossible to prevent leakage and breakage. A new system of clamping has recently been developed, whereby the pipes are held rigidly in place by suitably located castings, which are in most cases attached to the boiler. The method and arrangement of piping is very important, and to obtain best results ball jointed pipe unions should be used, and they should be located in a place accessible for tightening; also elbows should not be used when it is possible to bend the pipe. Copper pipes sometimes give trouble by wearing through where they come in contact with the sharp corners of metal cabs and running boards. In order to prevent trouble from this source, it is the custom on several roads to enclose the copper pipe at the exposed places with iron pipe of larger size.

It is the practice on some roads to give cabs a thorough examination every three months. And if they are found loose or in an unsafe condition proper repairs are made at once.

*Boiler Maintenance.*—The systematic use of blow off cocks in connection with soda ash treatment results in greater life of the flues, longer periods between washouts, decreased scale formation, and fuel economy. The following rules should be observed in the care of boilers at terminals:

When fires are being cleaned or dumped, the blower should be used only sufficiently strong to prevent smoke from emitting from the firebox door.

The fires of all engines awaiting service should be banked at the front flue sheet.

Unless absolutely necessary, injectors should not be used while fires are being cleaned, or when there is no fire in the firebox, nor while locomotives are being used on their own steam, without first brightening up the fire.

It is the consensus of opinion that boilers should be washed with hot water. When hot water is used the boilers should be filled through the blow off cocks located in the water legs; when cold water is used they should be filled through the injectors. In order to facilitate the work of washing large engines, suitable stands should be provided for the boiler washers, and portable troughs should be used to direct the stream of water from the mud ring into the pit. A sheet of canvas should be thrown over the part of the locomotive that will in any way become defective on account of the water from the boiler when washing. A sheet of canvas should also be placed over the engine truck, so that the cinders from the front end will not fall into the engine truck boxes.

The brick arch, like other boiler appliances, must be properly maintained in order to give effective service. It should not be disturbed except when absolutely necessary; when it is necessary to bore or work on the flues, only the center row of bricks should be removed. Only enough bricks should be taken out to enable the operator to get at the tubes, and they should be removed as carefully as possible to avoid breakage. To get best results special men should be assigned to the work of keeping up arches.

*Locomotive Inspection.*—Where the most satisfactory results are attained, inspection is made by a force of special inspectors who have been trained to inspect certain parts of the engine. This practice is followed at some of the important division points on the Pennsylvania Railroad. The head inspector examines the outside of the engine and tender, and looks at the trucks, wheels, draw gear, brake rigging, couplers, grab irons, footboards, pilot steps, and all safety appliances. He gages the couplers for height, wear of knuckles and heads, examines the knuckle-lock pins, etc. He examines driving wheels, flanges and



tires, main and side rods, brasses, knuckle pins, crosshead pins, crossheads and guides. He looks for loose pipes and clamps, oil cups and lids, cracks or breaks in the frame, working of the cylinders, missing or defective safety pins, and examines the valve gear, springs and spring rigging. He reports hot bearings, leaky washout plates or plugs, or any other defect that may come under his notice. He has charge of the other inspectors, and sees that each inspector makes out a report for each engine inspected. Another engine inspector starts in under the pilot and examines all parts under the engine and tender.

The head air brake inspector examines the brake valve, air pump, gages and governors, noting the dates on the tags. He reports them for attention after 30 days from the date on the tag. He examines air pipes and reservoirs, the sanding devices, gage glass and gage cocks. He is required to try them and blow them out. He notes the condition of the fire door, the apron and foot plate, washout plugs, sprinkling hose, etc. He examines the throttle gland to see if the packing will last until the engine is due for washing. His most important duty is to examine the crown and side sheets for leaks, and to note the condition of the flues. This examination is made in the presence of the engineer, and before he goes off duty. This inspector also examines the stay-bolt and boiler washout tags, notes when the engine is due for staybolt test or boiler washing, and keeps a book record of these items.

One duty of the head air brake inspector on roads equipped with track troughs is to lower the water scoop while the man underneath gages it, to see that it is neither too high nor too low. This man underneath is also an air brake inspector, and he examines all air pipes, hose and connections below the running board, brake rigging of engine and tender, notes the piston travel and locates leaks of every description.

The steam heat inspector examines all valves in the cab and at the rear of tender, all joints and pipes between engine and tender, and on front and rear. He tests the governor to operate at 100 lb., and reports any leaks or defects in the portion of the equipment for which he is responsible.

When these examinations have been completed, from four to five minutes being sufficient, each man writes his report on the proper form, and sends it by pneumatic despatch tube to the engine house office. By this means the reports covering the condition of the engine reach the work distributor's desk almost as soon as the engine reaches the ash pit.

#### DISCUSSION

The convention seemed generally in favor of assigning power, and several cases were mentioned where roads had gone back to the assigned power from a general pooling system. It was pointed out that the enginemen would be more interested in the condition of their locomotives, report defects that they otherwise would not bother about, and follow up the defects to see that they were properly corrected. As a general proposition, by assigning power the mileage between shoppings will be increased, the engines will be maintained in better condition, there will be a decrease in the cost of locomotive supplies, a decrease in locomotive failures, and a decrease in the necessary shop force to maintain the locomotives. It is also possible to locate the man that is not giving his engine proper attention. In the pool system one careless man will often cause defects on most of the engines he handles. N. B. Whitsel, of the Chicago & Western Indiana, which road handles the engines of several tenant lines, reported that a marked difference could be seen on engines used in the pooling system and those that were assigned to special engineers.

J. S. Sheafe, master mechanic, Baltimore & Ohio, pointed out that much could be done by the general foreman to decrease the time the engines are held at the terminal, mentioning that on one road it had been found that it took 19 hours to get a locomotive from the ash pit ready for service. In this connection, the inspection pit was spoken of as being of great advantage.

The Central of Georgia cover their inspection pits and find that the men will take more care in going over an engine, especially in rainy and hot weather. One member stated that 90 per cent of the engine failures could be charged to poor inspection and organization. The lack of organization has a great deal to do with the terminal delay.

In regard to the mileage between shoppings, some members took exception to comparisons that are frequently made, as in some cases, locomotives are much more heavily loaded than in others and again some roads have a different system of making repairs in the roundhouse and back shop which materially lengthens the time between general shoppings. Exception was taken to the author's cost of \$2,000 for general overhauling; it was believed that when the best grade of work is done and satisfactory material is used this cost will run up to \$2,500, or even to \$6,000, according to the size of the power.

Regarding economy in the engine house, it was pointed out that much could be done by keeping small material, such as shims, etc., in the storehouse ready for use. At the Burnside shops of the Illinois Central a meeting is held once a month of all the foremen in the plant, and economies around the plant are discussed and suggestions offered by the various foremen. The men are made to appreciate the cost of various articles and in this way are more particular as to the material they are liable to waste. A close supervision is kept on material and especially on scrap. In this regard, it is policy to specialize the work as much as possible, have certain men do piston work and certain men the rod work, etc. Several roads are cleaning their engines with oil and hot water, and find that it gives very good results.

The members seemed to be thoroughly in accord with the writer of the paper as regards the co-operation between general foremen, roundhouse foremen and the chief despatchers. Many times a foreman can so advise train despatchers in case of engine failures out on the road that much time can be saved and many times their advice will prevent a failure.

#### THE GENERAL FOREMAN AND SHOP EFFICIENCY

J. S. Sheafe, master mechanic of the Baltimore & Ohio, spoke on the relationship of the general foreman to shop efficiency. He pointed out that the general foreman must have a good organization. The sub-foremen should be capable of carrying the detail load in their respective departments, but at the same time, the general foreman should keep in touch with the work in a general way. A general foreman should use tact in dealing with his sub-foremen and treat them with the same respect that he would like to be treated by his superiors. Driving or rough treatment of the men has only a temporary effect. Efficiency does not always mean increased production, but includes the economical use of locomotive materials; do not scrap material too hastily.

A. Masters, of the Delaware & Hudson, in replying to Mr. Sheafe, mentioned that the capacity and ability of a general foreman are measured by the subordinates he has under him, and that he should so treat them that they will reflect to his credit. The opportunities for the general foremen are very good, as they are generally on the road to advancement and should train themselves accordingly.

#### ADDRESS BY A. P. PRENDERGAST

A. P. Prendergast, superintendent of machinery of the Texas & Pacific, gave an address from which the following is taken:

It is my conclusion, after nineteen years of practical contact with shop employees and conditions, that our men are largely what we, as foremen and supervisors, make them. The success of any organization or body of employees is dependent upon the manner in which they are directed and developed. It is difficult to establish and follow a defined system by which alone to govern the supervision of the various departments of our shops, and especially repair shops. It is, therefore, necessary to give study and consideration to each individual employee in order to under-

stand his fitness, and to bring out the best efforts of our men without resorting to undesirable methods.

Failure on the part of foremen and supervising officers of higher rank, to give sufficient thought to the adaptability of employees for the different lines of work, as well as a lack of interest in rendering assistance to employees as they undertake duties that may be new and difficult to them, is largely responsible for the aggressive attitude of many of the employees and the tactics to which they sometimes resort. The failure to show opportune acts of kindness and thoughtful consideration to our employees has resulted in lack of interest, which in some respects borders on disloyalty; employees who have been allowed to drift are usually influenced by other sources that do not contribute toward their improvement.

Lack of attention to details by foremen is a contributory cause of mental disturbance in employees, which in turn interferes with their capacity for production. I refer particularly to the failure of foremen to interest themselves in the matter of conveniences for employees in the handling of their work, as well as providing for their bodily comfort. It is a common condition in many shops to find employees trying to make headway with defective tools. Difficulty is also experienced because of delays to which they are subjected in securing their work from different departments; frequently this is the result of a privileged foreman being permitted by those in charge to demoralize the organization. The general foreman is one of the most important members of the organization in repair and manufacturing shops; the success of any shop management is largely dependent upon him. It is, therefore, essential that he set an example that will serve as a strong incentive and guide to the employees in his charge, both on and off duty. I have always found a large percentage of railway employees prone to follow their leaders. The necessity for shop supervisors to conduct themselves along lines that are above reproach is just as important to their success as it is for them to give their willing and continuous application to the duties and responsibilities entrusted to their care.

One of the most common causes I have found to be responsible for ineffective operation is the disposition to delay important duties until a more opportune time, which never arrives. How many times have foremen been heard to repeat some old complaint about conditions, the relations to some other department, etc., until it almost appears that this old trouble upon which he harps completely monopolizes his attention and energy, while still going along unimproved. At the same time many matters from which he could get some results, are going completely by the board.

Foremen should never lose sight of the obligations they are under in developing employees from the ranks to fit them for advancement. The officer in charge of men, who fails to educate and interest himself in the advancement of those under him, can be numbered with the indifferent leaders who have done much to promote antagonism and disloyalty in employees. I cannot urge too strongly upon all foremen, and all others engaged in a leading capacity, the great value derived from the study of the personality and capacity of the individual men under their jurisdiction in order that as necessity or opportunity presents itself, they may be in a position to put the right man in the right place. Beware of the "Indispensable" individual. An organization which rests upon such a one is, to say the least, unstable; the efficient manager, long before necessity for any changes develops, will have located the man qualified for advancement.

To properly start a foundation for the organization of shop employees we should begin with new employees entering the service, by directing their training along the lines that will develop their individual talents and create the appreciation that loyal employees have for their work and for leaders who take the proper interest in their progress. The instruction and development of apprentices on the part of those in charge is essential to the success of all departments. Co-operation is essential between departments; we must sacrifice the tendency to build a fence around

our own particular work. We have but one object, after all, which is to produce safe and economical transportation.

## VALVES, CYLINDERS, CROSSHEADS AND GUIDES

BY J. T. MULLIN

General Foreman, Lake Erie & Western, Lima, Ohio

Piston valves on superheated locomotives should be examined once every thirty days, as we find a great amount of carbonization of the oil occurs from high temperature. We find that in order to gain the speed power, and the saving of coal and water, piston valves with the Stephenson valve gear should be set in the negative lead for superheated locomotives. Slide valves are set at different positions; we find that for passenger service  $\frac{1}{4}$ -in. at 25 per cent. cut off, freight service  $\frac{3}{8}$ -in. at 50 per cent. cut off makes a very economical setting.

When locomotives are shopped the valves should be examined and put in first class condition. The slide valve seat should be faced and slightly spotted. Valve strips should be fitted in the valve grooves and the strips spotted to the friction plates. The spring should be properly adjusted so that grooves will not be worn in the friction plates. Piston valve and valve chambers when worn  $\frac{1}{32}$  in. should be bored, and new valve rings should be perfect fitted to the valve chamber and should be  $\frac{3}{32}$  in. larger than the valve chamber. Old rings reapplied should be at least  $\frac{1}{16}$  in. larger than the valve chamber.

The cylinder should be rebored when worn  $\frac{1}{16}$  in. out of round and should be bushed when not over  $\frac{3}{4}$  in. larger than the original size.

We find that on engines converted from saturated to superheated locomotives the cylinders have a tendency to crack between the valve chamber and the receiving ports of the cylinder. In order to overcome this we are applying a cross brace from front to back of it between the valve chamber and the cylinder, and drawing the metal together by shrinkage.

Piston heads should not be allowed to become more than  $\frac{1}{8}$  in. smaller than the cylinder; cylinder packing should be fitted to the cylinders; we believe that the Dunbar type of cylinder packing is the most economical for the length of service and less wear on our cylinders. Pistons should be examined at every shopping. Piston bearings in the heads and crossheads should be made with a taper of  $\frac{3}{4}$  in. to 12 in. All joints in the piston packing should be ground, properly fit to cup and rods, springs and retainers measured and made proper lengths and sizes. Guides and crossheads must be kept in first class shape at all times as they control the wear and life of the cylinders, packing and pistons. Guides should be lined and squared with the bore of the cylinders. Crossheads and crosshead gibs must be kept properly fitted and machined at all times.

### DISCUSSION

With the Stephenson valve gear a number of roads follow the practice of keying the eccentrics to the main axle before the wheels are under the engine. A record is kept of the position of the eccentrics so that the practice may be uniform on different engines of the same class. The Lackawanna has found trouble on superheater locomotives with the graphite lubricator because of carbonization, causing the piston rings to tilt, and blows resulting. It was stated that much trouble with valves may be eliminated by removing the relief valves and instructing the men to work steam to a stop. The practice of examining valves and piston rings periodically, generally every thirty days, seems to be quite general, but one member did not think it was necessary. He claimed that this method was too expensive and that satisfactory results could be obtained by the enginemens reporting trouble after it starts. Several members expressed the opinion that lack of lubrication was the cause of much cylinder and valve trouble where a little more oil would save much repair expense on rings and bushings. Two roads have done away with piston rod oil cups on superheater locomotives and use swabs with valve oil. This has been found to



reduce carbonization, as the enginemen, it was claimed, will use low grade oil in the oil cups and this carbonizes very easily.

### AUTOGENOUS WELDING

The report of the committee on Autogenous Welding, which was presented by the chairman, C. L. Dickert, Central of Georgia, will appear in the September issue of the Railway Age Gazette, Mechanical Edition.

### MAINTENANCE OF THE AIR BRAKE

BY CHAS. M. NEWMAN

General Foreman, Atlantic Coast Line, South Rocky Mount, N. C.

The position the air brake holds in relation to the present railroad traffic makes it one, if not the most, important device in use on the railroads today. The relation of the air brake to the successful handling of our present train is such that, without it, a road would be so congested in a few hours that a large percentage of its freight would perish before reaching its destination.

*Accessibility of Apparatus.*—As an assistance to maintenance the parts of the air brake requiring frequent attention should be accessibly located. It is a fact that when time is short and many repairs are to be made the parts most accessible will receive the attention and those inaccessible will be neglected. This results in lowering the efficiency of the brakes, in neglect of equipment and, after all, an increase in the cost of maintenance. Very often you will find brake cylinders so located, especially on locomotives, that it is necessary to remove them in order to apply a leather or gasket. Such conditions as these make maintenance expensive.

*Proper Installation.*—A good air brake equipment improperly installed is an expensive device from which efficient service cannot be obtained. The heart of the equipment, the air pump, should be made perfectly secure at its location, and so located that the intake will not be in a position to collect dirt and grit from the running boards or ashes from the pans when the fires are being cleaned or dumped. The air pump steam pipe should be connected to the boiler so as to insure dry steam at all times. Reservoirs and other parts which have several pipes connected to them should be fastened to some place as free from vibration as possible and the fastening should be made securely.

When a distributing valve is used, it should be applied to substantial brackets and these to a place free from vibration. Brake valves and signal valves should not be located too close to the boiler. Gages should never be fastened directly to iron brackets, but small blocks of soft wood, of a uniform thickness, should be used between the gage and the bracket. All piping should be put up with as few elbows as possible, using easy bends instead. In using a compound in fitting up air pipes, in all cases, it should be applied to the outside of the thread. When installing an air brake equipment or any part of the equipment, there are several very important facts to bear in mind:

Locate parts convenient for the repair man and the air brake operator.

Do not place parts, whose efficient operation is affected by heat, too close to the boiler.

Locate parts with pipes connected at a place free from vibration.

All parts must be free from any foreign matter before application.

*Methods of Inspection.*—Before any engine leaves the engine house its entire air apparatus should be given a thorough inspection and test by competent men, and all perceptible defects corrected. The air pump should be given an efficiency test to see that it is capable of supplying the necessary quantity of air under ordinary conditions. The brake levers, beams and hangers should be carefully watched, for frequently a repair man, at

an outside point, will replace one of these with one that may not be of correct dimensions. The proper time to inspect a train is on its arrival. To do this, the incoming engineer should add to the reduction required to stop, enough to fully set the brakes on the train. The inspectors should be present and make an immediate examination.

Terminal test plants are a great source of convenience for making inspection and tests; they also make possible lots of repairs that otherwise could not be made without delay; still they have their objectionable features. One of the grave evils of many test plants is the excessive amount of moisture due to insufficient cooling of the air.

*Terminal Repairs.*—Good brakes depend on the attention they receive at the terminal and all defects noted by the inspectors should be corrected. Such repairs as ordinary brake pipe leaks, defective hose gaskets, wrong piston travel, etc., which require little time should be made on the service tracks; but cars requiring heavy brake repairs should be marked for the repair tracks. Here is where good judgment must be exercised, as perishable or other very important loads or empties needed for such lading must not be delayed.

All cars in shops or on repair tracks with cleaning dates over nine months old should have their brakes cleaned and lubricated. Not only will the condition of brake cylinders and triples fully warrant this, but it is improbable that these cars will be so favorably located again for months, without causing delay and switching. When triples need cleaning they should be removed and sent to the shops, or some place fitted with a test plant, so that, after the operation of cleaning and lubricating, they can be placed on the test rack and given the required test. If all triples are removed from the bad order cars (which every road has a supply of stored for heavy repairs) and cleaned, lubricated and tested, you will find you will have an abundance of extra triples which can be used to replace those sent to the shop for attention. When the triples are being removed from "B. O." cars or engines, the air and signal hose should also be removed and applied to other equipment in service.

Since the introduction of the large and compound pumps, which are to take care of the increased number of cars in the train, most of us have been using this increase of air to take care of our air leaks, which is not only hard on the pump but expensive from a fuel standpoint. For the sake of illustration—

A certain large railroad system, which operates long trains successfully, has an allowable maximum train line leakage as follows: For trains from 25 to 50 cars, 7 lb. per min.; for trains from 50 to 75 cars, 6 lb. per min., and for trains from 75 or over, 5 lb. per min. Our average train is from 50 to 75 cars; the allowable leakage on this train is 6 lb. per min., or about 65.5 cu. ft. of free air, which is about the capacity of our single stage 11 in. air pump. Suppose to operate an 11 in. air pump, we require 200 lb. of coal per hour, or 4,800 lb. for 24 hours; estimating the coal at \$2 per ton it would cost \$4.70 to pump against a 6 lb. leakage for 24 hours.

#### METHOD OF MAKING REPAIRS ON THE ATLANTIC COAST LINE

*Air Pump Repairs.*—The cylinders are calipered and if the steam cylinder is found 1/32 in. out of round or 1/32 in. smaller in diameter in the center than at either end, it is removed from the center piece and bored out. If the air cylinder is found 1/64 in. out of round or 1/64 in. larger at any place than at another, it is bored out. We bore the cylinders four times, keeping them in sizes varying by 1/16 in. After a 9½ in. cylinder has been enlarged to 9¾ in. and run to its limit for wear, it is bored to 9⅞ in. and bushed to 9 7/16 in.

The air valves are ground in and applied with the cages and caps. After the caps have been well tightened the caps and valves are tested. The pistons are turned to an easy fit in the cylinder; the rods are trued. The cylinder packing rings are purchased from the manufacturer to fit the piston groove, and vary-

ing in size to fit the cylinders, allowing  $\frac{1}{8}$  in. for spring. The rings are applied to the pistons and the pistons applied to the pump, "King Type" metallic packing being used on the rods. In repairing the pump heads, if we find the main valve bushing not true, we ream it with a special adjustable hand reamer.

The slide valves are faced on a revolving aloxite wheel to a true bearing; the seats are faced with a file and scraper using the valve as a face plate. They are then ground in using kerosene oil and carborundum grain. If the left main valve cylinder head is not reasonably true, it is discarded. If the reversing valve piston rod and bushing are not in good condition, new parts are applied. After the pump is assembled, it is placed on a test rack, and after running it several hours it is given all required tests before it is placed into service. We require twelve months ordinary service from all pumps between general repairs.

*Brake Valve Repairs.*—The rotary valve and seat are faced by hand, as we have not yet been able to machine them perfectly. If the bottom case bushing is not perfectly true, it is reamed with a special adjustable hand reamer. The equalizing piston packing ring is fitted to the piston groove and the cylinder. If the equalizing piston packing ring groove is worn, we close it to a template, using a specially constructed press for the operation. This effects a saving of about \$0.75, as a new piston would have to be applied.

*Feed Valve Repairs.*—Before any repairs are made to the feed valves we thoroughly clean them, using kerosene oil, gasoline and compressed air, and place them on the test rack to locate all the defects. A good fit for the feed valve piston in the bushing is very necessary. If the bushing is not perfect, we ream it with a special adjustable hand reamer. The piston is then spread to fit the bushing, and the spider is also spread to fit its guide. These spreading devices are simple and are home-made tools which effect a saving of about \$0.87, the price of a new piston.

*Distributing Valve Repairs.*—After dismantling, the body of the distributing valve is sent to the lye vat and placed in boiling lye water for about five minutes; if left in longer, they seem to warp and will require considerably more work to repair. All small parts are cleaned with gasoline and the valve is assembled. It is then placed on a No. 6 ET test rack and given all tests, and if no defects develop it is returned to service.

*Triple Valve Repairs.*—All triples sent in for repairs are first cleaned with a wire brush wheel, and all bruises removed from the gasket side with a file. The piston slide and graduating valves are placed in kerosene oil, and afterwards washed in gasoline and blown off with compressed air. The emergency valve seat is cleaned by using No. 0 emery cloth on a smooth surface. The feed groove is cleaned out with a piece of hard wood. The triple bushing is cleaned out with a piece of cheese cloth and blown out with compressed air. Never use waste in cleaning triples. The slide and graduating valves are lubricated with dry graphite. The spider end of the piston, as well as the ends of the slide valve spring, are also lubricated with dry graphite.

About three drops of anti-friction triple valve oil is applied to the cylinder bushing, spreading it evenly over the surface on the train line side of the piston. After assembling, the triple is placed on the test rack and given all tests.

All the cleaning operations are performed by handy-men on a piece work basis, except the test rack operator who is a day rate man. Any triple which fails to stand the test on account of improper work done by the cleaners, is returned to them for correction, without compensation. Triples, which, during tests, show bad bushings or leaky packing rings, leaky graduating or slide valves, are so marked and delivered to the triple valve machinists for repairs.

*Brake Cylinder Repairs.*—In making repairs to brake cylinders, notice should be taken of the piston fit in the cylinder. The packing leather should be soft and pliable and thoroughly lubricated with a good grease. When applying the leather and

expanding ring, care should be taken to see that the ring has an even bearing on the leather, and that the leather has a smooth, even bearing on the walls of the cylinder. The follower should not clamp the expanding ring, but simply keep it in place and hold the leather to the piston.

#### DISCUSSION

The chief point in the discussion on this subject was that the various parts of the air brake apparatus should be located in accessible places as many times it has been found extremely difficult to make satisfactory repairs on account of the poor location of the part that was to be worked on. Vanadium steel was recommended for air brake piston rods, and it was believed that these rods should be made with the sharp taper of  $2\frac{1}{4}$  in. to the foot, rather than having a shoulder in the piston fit, as they would give much better life and eliminate breakage to a great extent. A few members reported that they had workmen sufficiently expert to get a satisfactory seat on the rotary valve in a lathe without finding grinding necessary.

#### TAYLOR SYSTEM

BY W. W. SCOTT

General Foreman, Delaware, Lackawanna & Western, Buffalo, N. Y.

The "Taylor System" so called, is putting into effect the principles of scientific management. Methods of doing business change, and two phrases describe this gradual change in business: "Specialization-of-work" and "mass-production." Machinery has taken the place of workmen, and with this gradual change in business has come as gradually but as surely a change in methods of handling work.

The one-man business is a back number. Instead, the authority of the one man has been divided into sections; each section has been given in charge of an individual who is responsible for carrying it out, as work has grown in bigness the more has it been sub-divided into units.

Two men's names are intimately associated with this newer idea of management: F. W. Taylor and Harrington Emerson. Both have the same object. They differ principally in methods. Mr. Taylor's system offers a sub-division of the old organization and divides all work into two phases: Planning and execution. Mr. Emerson's application of scientific management is based upon twelve principles of efficiency. He retains the old organization, but a staff organization is added; specialists who plan and outline the more efficient principles for the old organization to carry out.

After a careful analysis of the scientific principles of either the Taylor or Emerson school, we may find in many of the details nothing entirely new in doing work. The shop manager may have a much better way in handling some detail, but the new principles should not be confused with methods. If you have the principles of scientific management and a purpose to carry them out, any man get results though his methods of applying the principles may vary.

Frederic M. Feiker offers these principles as the ground work upon which to build a structure dedicated to scientific management:

To separate from the "line organization" or to add to the "line organization" a staff officer or "staff organization."

To set up tentative standards of performance.

To correct these standards by working out scientifically the best methods of performance.

To determine the best inducement to the employee to attain these standards.

To equip the employee with clear, complete and exact knowledge of the best and quickest way of doing the work.

Although scientific principles of management were first applied to the operation of machine shops by Fred W. Taylor, the principles have come to be universal. They can be applied even to millinery shops with wonderful results, and they have



been successfully applied to a wide range of industrial activity.

All wage payments under scientific management are based on four principles:

A large daily task for each man in the shop.

Standard conditions. Each man's task should call for a full day's work.

High pay for success. Any man should be sure of large pay when he accomplishes a task.

Loss in case of failure; when he should be sure that sooner or later he will be the loser by it.

It will be seen there is nothing radically new in these principles, and they do not propose any mechanical method of handling the question of wage payment.

In the Bethlehem Steel Works where F. W. Taylor has put his principles of management into operation, all these methods of wage payment were employed under scientific management, but two methods proved particularly successful in introducing standard methods of work into the shop.

One, the differential piece rate system invented by Mr. Taylor; the other, the task and bonus system invented by H. L. Gantt. Of these two systems, the task and bonus system has proven to be particularly applicable in changing over from former methods to more exact and scientific methods of management in shops.

In the differential piece work system, work is paid for by the piece. Time studies form the basis for making a minimum piece-work price. The only difference between the scientific piece-work rate and that in the average shop, is that the scientific piece-work rate is based on our exact knowledge of the time for detailed operations of doing a job—not one man's judgment, or two men's judgment, of the time it ought to take to do the work, but an analysis of the exact time taken with a stop-watch by a trained investigator when different workmen work on the same job, under ideal conditions, with the best tools, the best material, and the best working arrangements that the manufacturer can supply.

The history of the development of scientific management up to date calls for a word of warning. The mechanism of management must not be mistaken for its essence or underlying philosophy. Precisely the same mechanism will in one case produce disastrous results, and in another the most beneficent. The same mechanism which will produce the finest results when made to serve the underlying principles of scientific management, will lead to failure and disaster if accompanied by the wrong spirit in those who are using it.

Mr. Taylor, in his paper on "Shop Management," has called special attention to risks which managers run in attempting to change rapidly from the old to the new management. The philosophy of scientific management is contained in four underlying principles:

The development of a true science; the scientific selection of the workmen; his scientific education and development; intimate friendly co-operation between the management and the men; in other words substitute science for the rule of thumb; harmony for discord, co-operation, not individualism, maximum out-put in place of restricted out-put and the development of each man to his greatest efficiency and prosperity.

#### OTHER BUSINESS

J. Hannahan, formerly chief of the Firemen's Brotherhood and now a representative of the Locomotive Stoker Company, addressed the association, pointing out to the members the necessity of all railroad men working together to prevent so much adverse legislation that has proved to be merely political ammunition. Every railroad man should exert what influence he can to impress his representatives in either the state or federal legislatures, that they should treat the railroads fairly. He also spoke of the vast opportunities ahead of general foremen, mentioning a number of prominent men who have worked up through this position.

The following officers were elected for the ensuing year:

President, W. W. Scott, general foreman, D. L. & W., Buffalo, N. Y.; first vice-president, L. A. North, superintendent of shops, Illinois Central, Chicago; second vice-president, Walter Smith, Chicago & North Western, Chicago; third vice-president, W. T. Gale, machine foreman, Chicago & North Western, Chicago; fourth vice-president, W. G. Reyer, general foreman, Nashville, Chattanooga & St. Louis, Nashville, Tenn.; secretary-treasurer, Wm. Hall, Chicago & North Western, Winona, Minn. The secretary reported a membership of 219 and a cash balance of \$68.25.

The executive committee met immediately after the adjournment of the convention and chose the following subjects for the next annual convention: Valves and Valve Gearing, Rods, Tires, Wheels, Axles and Crank-Pins; Shop Efficiency; Oxy-Acetylene Welding; and Roundhouse Efficiency. The convention for 1915 will be held in Chicago some time during the month of July.

## DISTRIBUTION OF ENERGY IN A LOCOMOTIVE AND IN ANIMALS

BY PROF. ARTHUR J. WOOD  
The Pennsylvania State College

A comparison of one locomotive with another on the basis of efficiency, economy or performance often leads to better designs. As methods of testing become more and more refined, such comparisons have new interest and importance. In the modern locomotive testing plant, it is possible to account for the losses of heat when the coal is burned in the firebox and during the various transfers of heat in the boiler, cylinder and driving mechanism, until finally it is found that from four to seven per cent of the heat energy in the fuel is used at the track to haul the load.

In the same general way, by putting an animal in a calorimeter, corresponding to the testing plant, it is possible to account for the various losses in feeding stuffs, as hay, bran and grain. This calorimeter is essentially an insulated, enclosed stall into which a measured quantity of air, food and water may be supplied and is so arranged that an accurate accounting may be made of the quantity and quality of gases and refuse and of the heat given off by the animal placed therein; and finally of the amount of energy consumed or rejected during the different processes of assimilation and nutrition. It is thus possible to account for the energy finally recovered and available for simple locomotion of the body and in hauling a load. From such a study, we find that the animal, classed purely as a machine, is capable of using energy in the fuel supplied from five to ten times as efficiently as is possible in a modern locomotive. This should not be taken as meaning that according to our usual standards, the locomotive is not an efficient machine. Regarded as a power plant, its efficiency under favorable conditions compares favorably with that of a stationary power plant of the same output using reciprocating engines.

For many years there has been in operation at the Pennsylvania State College the only complete animal calorimeter in this country. The investigations cover a large range of feeding stuffs and the results are important. Dr. H. P. Armsby, Director of the Institute of Animal Nutrition at the college, has brought together for this study the results of some of these tests. The figures here given apply to steers, cows and sheep, but not to horses or hogs. In the case of a draft horse, he states that about 31 per cent of the available energy can be recovered as useful work.

The values for the locomotive are given in round numbers and were calculated by the writer from data from locomotive testing plant results of a large Pacific type locomotive, stoker fired, with a superheater and burning Penn Gas coal. While no absolute comparison can be made between the energy rejected and recovered by the animal and by the locomotive, still the analogy in the case should be quite apparent.

An essential difference in this comparison is that the animal is not a heat producing machine and therefore the energy of digestion is not determined by ranges of temperatures. Taking the mixed grain as an average of the four feeding stuffs, it may be noted that 37.5 per cent of the energy supplied is available to the body for locomotion and for work. The losses in this case in the feces is less than a half of what it is for timothy hay per pound. The fuel (hay) is not as well "burned" as is the grain, but the two have nearly the same heat value per pound.

PERCENTAGE DISTRIBUTION OF ENERGY OF FEEDING STUFFS

	Timothy	Wheat bran	Mixed grain	Corn meal
1—Energy of feed as consumed .....	100.00	100.00	100.00	100.00
2—Energy rejected unused in excreta:				
(a) In feces .....	46.38	31.51	20.04	9.21
(b) In urine .....	3.67	5.42	6.86	3.83
(c) In combustible gases .....	6.75	7.36	7.95	9.30
	56.80	44.29	34.85	22.34
3—Energy liberated in body .....	43.20	55.71	65.15	77.66
4—Energy expended in digestion and converted into heat	18.88	24.88	27.70	23.98
5—Energy available to the body .....	24.32	30.83	37.45	53.68

PERCENTAGE DISTRIBUTION OF ENERGY OF DRY COAL IN LOCOMOTIVES

1—Energy of feed (fuel) as consumed.....	100.00
2—Energy rejected unused—	
(a) In ashes, sparks, radiation and unaccounted for....	21.0
(b) In water vapor and heating water.....	5.5
(c) In unburned combustible gases.....	18.0
	44.5
3—Energy liberated in the body of the locomotive.....	55.5
4—Energy expended in boiler and cylinders and converted into heat*	49.0
5—Energy available to do work .....	6.5

\*This energy is not available to do work at the track.

Note also that the energy "liberated in the body of the locomotive" is about the same as the energy "liberated in the body" of the animal, but that the energy expended and converted into heat in the latter case is twice as much as in the former, a significant fact in the study of the betterment of the man-made machine.

If one will consider for a moment it will become evident that the locomotive works thermodynamically at a disadvantage when compared with the animal power plant in that the temperatures in the animal are not over 102 deg. F., so that the conduction and radiation factors are relatively low. Again, there is no comparison possible with steam cylinders, where the highest possible efficiency is limited by the temperatures of the vapor in the ratio  $(T_1 - T_2) \div T_1$  where  $T_1$  is the absolute initial and  $T_2$  the absolute final temperature. This ideal efficiency in a reciprocating engine seldom exceeds 35 per cent. On the other hand, high ranges of temperature are essential to high efficiency during expansion, indicating that the animal's over-all efficiency is high notwithstanding this thermal disadvantage.

From any standpoint, the study leads to the conclusion that the created organism far excels the man-made machine on the basis of the energy available to do work.

**ALUMINUM FOIL.**—The manufacture of aluminum foil is a growing industry of southwestern Germany. The foil is used in place of tin foil for wrapping candied fruit, and the like, possessing several advantages over the tin.—*The Engineer.*

**ELECTRICITY TO PREVENT FREEZING.**—By keeping currents of several hundred amperes flowing continuously through water pipes which otherwise would have been in danger of freezing, it was possible to continue construction work on a hydro-electric development on the St. Lawrence river without interruption during even the coldest days of the past winter. The one inch pipes thus protected supplied water for the steam shovels and were laid above ground, as continuous shifting prevented them from being buried.

## ELECTRIC LOCOMOTIVE DATA

BY F. D. EVERETT

The accompanying tables give complete data on many types of electric locomotives in heavy railway service in this country and abroad. One may see at a glance the general characteristics of the types preferred by the different railroads.

In Table I information is grouped concerning 8 American and 17 European single phase locomotives.

Table II covers 12 direct current locomotives of American and 3 of European manufacture. Two of the European are not for main line service, but are given because constructed for direct current at 3,000 and 2,000 volts respectively. The third was for use in Canada.

Table III contains data for 5 foreign and one American 3-phase locomotives, while Table IV deals with the locomotives using current of a different sort in the motors from that collected by the trolley.

Thus it is seen that only in this country has direct current been used for heavy electric traction. Abroad the higher direct current voltages have been employed on interurban lines with multiple unit car service, but have not been tried on main line work. Italy uses the three-phase system for its advantages on heavy grades, while the other countries prefer single-phase with 10,000 to 15,000 volts on the trolley and a frequency of 15 or 16 2/3 cycles.

The differences between American and European design are well brought out by these tables. On this side the prevailing method is to use a gearless or single reduction geared drive with one or two motors per driving axle, thus keeping down the size and capacity of the motors. Abroad the custom is to use coupled driving axles driven from a countershaft which is connected to one or more large motors by cranks and connecting rods, or by yokes or gearing. This use of gearing between motor and countershaft is only to be found on the newest locomotives. Flexibility is given the long wheel base of coupled axles by allowing the outer driving axles a certain amount of end play or by even using flangeless wheels on the middle axle as in the latest Löttschberg locomotive. The foreign design was perhaps influenced in the use of side rod drive by the fact that these were specified for the first German locomotives by the government railway officers who thought by this type of construction to reduce complication and keep the running gear as similar as possible to that of steam locomotives. The geared countershaft is the drive preferred by the foreign designers and has been accepted by Prussian government officers as satisfactory.

The only exceptions in the United States to the general American practice are the new Norfolk & Western and the Pennsylvania locomotives. The latter road chose the side rod drive in order to obtain the high center of gravity which their tests had shown to be so essential for preservation of the road bed. The Vienna City 3,000-volt, three-wire locomotive used a geared drive of two motors per axle. The Paris, Lyons & Mediterranean locomotive had a bevel gear drive with the motors placed lengthwise of the body.

Table V gives the average values of weight per horse power and maximum starting tractive effort per 100 lb. of adhesive weight. The three-phase locomotive is the lightest per horse power and has the greatest available starting tractive effort per 100 lb. of adhesive weight. The Great Northern placed extra ballast weights on the locomotive in order to utilize the full starting power of the motors. Likewise in the Giovi locomotives provision has been made to increase the weight from 132,000 lb. to 165,000 lb. if (in the future due to increase of train length) the full starting torque of the motors is needed.

American single-phase locomotives average around 180 lb. per horse power, but as most of these are equipped for direct current as well as alternating current operation and have train



TABLE I

Road	Supply		Type of service	Placed in operation	Manufacturer	Type of drive	Wheel arrangement	Drivers, diam. in inches	Length, Ft. In.	Wheel base			Total I. P.					
	Volts	Freq.								Total	Rigid	Num-ber						
N. Y. N. H. & H.	11,000	25	Pass and frt.	1906	Westinghouse	Gearless (quill)	0-4-4-0	62	36	4	22	6	7	6	4	1,000	800	
N. Y. N. H. & H.	11,000	25	Pass and frt.	1909	Westinghouse	Gearless (quill)	2-4-4-0	62	36	4	30	10	11	8	4	1,000	800	
N. Y. N. H. & H.	11,000	25	Freight	1910	Westinghouse	Gearless (quill)	2-4-4-2	63	48	..	38	6	7	..	4	1,400	1,200	
N. Y. N. H. & H.	11,000	25	Pass and frt.	1912	Westinghouse	Gearless (quill)	2-4-4-2	63	50	..	40	6	8	..	8	1,360	1,160	
N. Y. N. H. & H.	11,000	25	Switching	1911	Westinghouse	Gearless (quill)	0-4-4-0	63	37	..	23	6	7	..	4	770	500	
Grand Trunk	3,000	25	Pass and frt.	1908	Westinghouse	Gearless (quill)	0-6-0	62	23	6	16	..	16	..	3	750	..	
Boston & Maine	11,000	25	Pass and frt.	1911	Westinghouse	Gearless (quill)	2-4-4-2	63	48	..	38	6	7	..	4	1,400	1,200	
Pennsylvania	11,000	15	Passenger	1907	Westinghouse	Gearless (quill)	4-4-4-4	72	62	..	55	10	7	6	4	2,000	1,500	
Loetschberg	15,000	15	Pass. and frt.	1911	Oerlikon	Gearless countershaft	0-6-6-0	53	49	6	23	4	2	3	4	2,000	2,000	
Loetschberg	15,000	15	Pass. and frt.	1913	Oerlikon	Gearless countershaft	2-10-2	53	52	6	37	2	14	9	2	..	2,500	..
Dessau-Bitterfeld	10,000	15	Passenger	1910	A. E. G.	Side rod and jack shaft.	4-4-2	63	41	..	29	6	9	10	1	1,000	700	
Dessau-Bitterfeld	10,000	15	Freight	1910	Siemens-Schuckert.	Side rod and jack shaft.	0-8-0	41.4	34	6	15	9	7	3	1	800	600	
Lauban-Konigzell	10,000	15	Pass. and frt.	1913-14	Brown-Boveri Cie.	Gearless	0-6-6-0	..	..	..	..	..	..	..	4	1,500	1,200	
Lauban-Konigzell	10,000	15	Freight	1913	Siemens-Schuckert.	Gearless c. shaft.	0-4-4-4-0	53	56	6	44	6	9	6	3	1,500	1,200	
Lauban-Konigzell	10,000	15	Pass. and frt.	1912	Siemens-Schuckert.	Side rod and jack shaft.	2-8-2	45.3	46	5	34	10	8	2	1	1,700	..	
Magdeburg-Leipzig-Halle	10,000	15	Pass. and frt.	1912	A. E. G.	Gearless c. shaft.	0-4-4-0	53	36	10	26	2	9	6	2	1,000	600	
Magdeburg-Leipzig-Halle	10,000	15	Pass. and frt.	1912	Maffei-Schwarzkopf.	Side rod and jack shaft.	2-6-2	63	43	..	31	6	..	..	1	1,800	1,100	
Wiesental	10,000	15	Pass. and frt.	1912	Brown, Boveri & Cie	Scotch yoke	2-6-2	59	39	2	28	2	15	8	2	950	780	
Wiesental	10,000	15	Pass. and frt.	1910	Siemens-Schuckert.	Side rod and 2 shafts.	2-6-2	47	43	2	31	2	11	6	2	950	780	
Midi	12,000	16 2/3	Pass. and frt.	1911	A. E. G.	Side rod and 2 shafts.	2-6-2	51	43	..	31	6	11	10	2	1,600	1,200	
Midi	12,000	16 2/3	Pass. and frt.	1911	French Westingh'se	2 geared c. shafts.	2-6-2	47	37	3	28	11	13	2	2	1,200	..	
Midi	12,000	16 2/3	Pass. and frt.	1911	Jenmont	Gearless (quill)	2-6-2	55	46	9	34	10	12	6	3	1,500	1,200	
Valle-Maggia	5,000	20	Mountain	1911	Oerlikon	Gearless c. shaft.	0-4-0	..	21	6	10	10	10	1	1	250	..	
Swedish Rys.	15,000	15	Passenger	1912	Siemens-Schuckert.	Side rods and c. shaft.	4-4-4	62	42	4	32	6	..	..	1	1,250	740	
Swedish Rys.	15,000	15	Freight	1912	Swedish A. E. G.	Side rods and c. shaft.	0-6-6-0	47.5	52	..	38	5	..	..	2	1,660	1,100	

Road	Tractive effort		Weight in lb.		Speed at cont. rating		T. E. in per cent. of adhesive wt.		T. E. per H. P.		Reference	
	Maximum	Hourly	Total	On drivers	Max. speed, in. p. h.	Cont. rating	Max.	Cont.	Max.	Cont.		
N. Y. N. H. & H.	20,000	10,000	180,000	180,000	70	40	11.1	4.2	180	20	9.4	St. Ry. Jour., Vol. 27, p. 588; Vol. 130, p. 278.
N. Y. N. H. & H.	20,000	10,000	204,500	154,000	70	45	13.0	4.8	205 (196) †	20	9.4	Ry. Age Gaz., Vol. 45, p. 1472.
N. Y. N. H. & H.	40,000	14,000	260,000	188,000	50	35	21.3	6.4	186 (172) †	28.5	10	El. K. u. B., 1909, p. 574.
N. Y. N. H. & H.	40,000	14,000	240,000	182,000	50	45	22.0	6.6	176	29.4	10.3	Ry. Age Gaz., Vol. 52, p. 1608.
N. Y. N. H. & H.	36,000	..	158,000	158,000	26	11.5	22.8	9.4	206	46.8	29.6	Ry. Age Gaz., Vol. 51, p. 118.
Grand Trunk	43,600	..	132,000	132,000	35	25	33.0	5.3	176	58.0	..	Ry. Age Gaz., Vol. 45, p. 1346.
Boston & Maine	49,000	25,000-F	260,000	192,000	45-F	21-F	25.6	11.2-F	186	35	17.8-F	Am. Engr. & Ry. Jour., Nov., 1911.
Boston & Maine	14,000-P	12,000	280,000	200,000	50-P	38-P	20	4.6	140	20	6.1	R. R. Gaz., Nov. 22, 1907.
Pennsylvania	40,000	14,700	198,000	198,000	..	61	16.7	11.1	99	16.5	11.0	El. Ry. Jour., Vol. 38, p. 190.
Loetschberg	33,000*	28,600*	236,000	198,000	43.5	26.1	31	12.9	95	15.9	8.9	El. Ry. Jour., Vol. 42, p. 1048.
Loetschberg	39,600	29,700†	232,000	172,000	46.5	31	23	6.8	132	19	6.0	El. Kraft u. Bahn, Vol. 8, p. 281.
Dessau-Bitterfeld	19,000	11,000	132,000	123,000	68	53	..	..	153	27.5	..	Eng. News, Vol. 66, p. 554.
Dessau-Bitterfeld	22,000	19,800	123,000	123,000	44	..	17.9	..	..	..	..	Ry. Gazette (London), Oct. 4, 1912.
Lauban-Konigzell	36,300	..	185,000	185,000	28	12.4	19.6	11.3	123	24.2	17.4	El. K. u. B., Vol. XI, p. 112.
Lauban-Konigzell	36,300	..	203,000	141,000	62	50	28	..	120	23.2	..	El. K. u. B., Vol. XI, p. 112.
Lauban-Konigzell	26,400	..	156,000	99,000	40.4	21.7	..	..	..	26.4	..	Ry. Gazette (London), Oct. 4, 1912.
Magdeburg-Leipzig-Halle	17,600*	11,000	141,000	92,500	68.4	56	17.8	6.7	87	9.8	6.0	El. Ry. Jour., Vol. 38, p. 957.
Wiesental	19,900	8,800	150,000	92,500	..	46	21.5	7.2	148	21	8.5	Le Genie Civil, Vol. 58, p. 347.
Wiesental	17,640	8,830	180,000	119,000	..	46	19.1	7.2	158	18.5	8.5	El. Ry. Jour., Vol. 35, p. 668.
Midi	27,400*	17,600*	178,000	119,000	46.5	37.2	23	7.7	112	17.1	7.7	Le Genie Civil, Vol. 58, p. 347.
Midi	27,500	17,600	176,000	119,000	..	37.2	23.1	7.7	148	22.9	..	Le Genie Civil, Vol. 58, p. 347.
Midi	27,500	17,600	176,000	119,000	..	37.2	23.1	7.7	117	18.3	7.7	Le Genie Civil, Vol. 58, p. 347.
Valle-Maggia	7,980	..	45,800	45,800	25	..	17.4	..	183	..	..	Schweiz. Rou., July 15, 1911.
Swedish Rys.	6,850	..	154,000	66,000	62	62	..	6.5	123	..	..	El. Ry. Jour., Vol. 37, p. 788.
Swedish Rys.	18,800	11,300	218,000	218,000	37	31	..	5.2	131	..	..	El. Ry. Jour., Vol. 37, p. 788.

† 1 1/2 hour rating. \* Drawbar pull. † Excluding direct current control and heating equipment.

TABLE II

Road	Supply		Type of service	Placed in operation	Manufacturer	Type of drive	Wheel arrangement	Length		Wheel base			Total H. P.
	Volts	Freq.						Ft. In.	Ft. In.	Total	Rigid	Num-ber of	
N. Y. C. & H. R.	600	34 rail	Passenger	1906	G. E. Co. & Am. Loco.	Gearless	2-8-2	37	27	13	13	4	2,200
N. Y. C. & H. R.	600	34 rail	Passenger	1907-08	G. E. Co. & Am. Loco.	Gearless	4-8-4	44	36	13	13	4	2,200
N. Y. C. & H. R.	600	34 rail	Passenger	1913	G. E. Co. & Am. Loco.	Gearless	0-4-4-4-0	44	43	6	6	8	2,000
N. Y. C. & H. R.	600	34 rail	Passenger	1913	G. E. Co. & Am. Loco.	Gearless	0-4-4-4-0	36	55	45	7	6	2,600
N. Y. C. & H. R.	600	34 rail	Passenger	1909	Westinghouse	Side rods and c. shaft	4-4-4-4-0	68	64	11	55	11	2,500
Pennsylvania	600	34 rail	Pass. and frt.	1909	G. E. Co.	Twin gearing	0-4-4-0	48	39	6	27	6	1,450
Detroit Tunnel	600	34 rail	Pass. and frt.	1910	G. E. Co.	Twin gearing	0-4-4-0	40	39	6	27	6	1,450
Baltimore & Ohio	600	34 rail	Trolley	1912	Dick, Kerr & Co.	Gearless	0-4-4-0	42	31	24	6	8	650
Brit. Co. Ry.	600	Trolley	Freight	1912	Westinghouse	Gearless	0-4-4-0	36	31	23	4	6	400
Brit. Co. Ry.	600	Trolley	Freight	1912	Westinghouse	Gearless	0-4-4-0	36	31	23	4	6	400
Fort Dodge, Des Moines & So.	600/1,200	Trolley	Freight	1912	Westinghouse	Gearless	0-4-4-0	37	35	25	7	4	1,000
Southern Pacific	1,200/1,500	Trolley	Freight	1912	Westinghouse	Gearless	0-4-4-0	37	35	25	7	4	1,000
Piedmont Tr. Co.	1,500	Trolley	Freight	1913	G. E. Co.	Twin gearing	0-4-4-0	46	37	4	26	8	1,250
Butte, Anaconda & Pacific	2,400	Catenary	Frt. and pass.	1907	G. E. Co.	Gearless	0-4-4-0	49	34	2	32	9	520
Vienna City	3,000 (3 wire)	Catenary	Ore*	1906	Siemens-Schuckert	Gearless	0-4-4-0	49	34	2	32	9	640
Moselhütte	2,000	Catenary	Ore*	1906	Siemens-Schuckert	Gearless	0-4-4-0	49	34	2	32	9	640

Road	Traction effort		Weight in lb.	Speed at rating	T. E. in per cent. of adhesive wt.	Lb. wt. per 1 hr. H. P.	T. E. per H. P.		Reference
	Max. num	Contin. num					Max. 1 hr.	Cont.	
N. Y. C. & H. R.	32,000	6,000	190,000	75	60	86.5	14.5	6.1	Ry. Gaz., Vol. 40, p. 653; El. Ry. Jour., Vol. 32.
N. Y. C. & H. R.	32,000	6,000	140,000	75	60	105	14.5	6.1	Ry. Age Gaz., Vol. 46, p. 1526.
N. Y. C. & H. R.	33,500	9,500	230,000	60	60	100	14.5	5.9	G. E. Review, May, 1913.
N. Y. C. & H. R.	20,000	14,000	200,000	60	60	86	14.5	5.9	El. Ry. Jour., Nov. 8, 1913.
Pennsylvania	69,200	25,000	332,100	88	60	133	27.7	9.3	Ry. Age Gaz., Vol. 47, p. 881.
Detroit Tunnel	60,000	11,200	199,000	35	22	124	31.7	6.9	Ry. Age Gaz., Vol. 47, p. 320.
Baltimore & Ohio	25,000	16,000	180,000	50	38	172	38.5	20.8	El. Ry. Jour., Vol. 36, p. 1067.
Brit. Co. Ry.	26,000	8,000	112,000	18	18	150	43.3	27.2	El. Ry. Jour., Vol. 39, p. 37.
Brit. Co. Ry.	24,000	12,800	85,000	14	14	120	30	30	El. Ry. Jour., Vol. 39, p. 826.
Fort Dodge, Des Moines & So.	30,000	11,500	120,000	20.5	20.5	118	38.4	28.5	Ry. & Loc. Eng., June, 1910.
Southern Pacific	27,000	13,700	110,000	45	21	126	38.4	28.5	El. Ry. Jour., Vol. 41, p. 1010.
Piedmont Tr. Co.	48,000	25,000	160,000	45	21	118	38.4	28.5	El. Review, 1907, p. 176.
Butte, Anaconda & Pacific	48,000	25,000	60,000	45	21	118	38.4	28.5	El. K. u. B., Vol. 5, pp. 565 and 585.
Vienna City	.....	.....	121,000	.....	.....	189	.....	.....	
Moselhütte	.....	.....	121,000	.....	.....	189	.....	.....	

\* 16.2 km. of single track, 1 meter gage. † Speed at hour rating.

TABLE III

Location	Supply		Type of service	Placed in operation	Manufacturer	Type of drive	Wheel arrangement	Length		Wheel base			Total H. P.
	Volts	Freq.						Ft. In.	Ft. In.	Total	Rigid	Num-ber of	
Simpton	3,000	15	Pass. and frt.	1908	Brown-Boveri	Scotch yoke	0-8-0	49.3	38	2	26	3	1,700
Simpton	3,000	15	Pass. and frt.	1906	Brown-Boveri	Scotch yoke	2-6-2	64.5	40	4	31	5	1,150
Valtellina	3,000	15	Pass. and frt.	1908	Ganz El. Co.	Side rods	2-6-2	60	37	10	31	2	1,500
Valtellina	3,000	15	Passenger	1905	Ganz El. Co.	Side rods	2-6-2	59	37	10	31	2	1,200
Giovi	3,000	15	Pass. and frt.	1910	Italian Westinghouse	Scotch yoke	0-10-0	42	43	3	20	1	1,440
Great Northern	6,600	25	Pass and frt.	1908-09	G. E. Co.	Twin gearing	0-4-4-4-0	60	44	2	31	9	1,900

Location	Tractive effort		Weight in lb.	Speed, m.p.h.	Speed control	Resistance
	Max. num	Normal at different speeds				
Simpton	.....	24,600-21,800	150,000	16-22-32-44	Pole changing	16.4
Simpton	30,800	16,100-13,200	136,500	22-44	Pole changing	14.3
Valtellina	26,500	13,200, 7,700, 7,700	136,500	16-26-40	2 motors of different number of poles	14.3
Valtellina	.....	13,000-7,000	124,000	20-40	Cascade and resistance	15.4
Giovi	.....	19,500 (1 hr.)	132,000	19-28	Cascade and water resistance	14.7
Great Northern	80,000	47,600 (1 hr.)	230,000	15	Resistance	16.2
Great Northern	.....	37,400 (Cont.)	230,000	15	Resistance	120*

\* Locomotive ballasted to give sufficient adhesion for maximum tractive effort.



TABLE IV

Road	Supply		Type of service	Placed in service	Manufacturer	Type of drive	Wheel arrangement	Drivers, diam. in inches	Wheel base		Total H. P.
	Volts	Freq.							Total	Rigid	
Paris, Lyons & Mediter....	13,000	25	Pass. and ftr..	1911	Anvert-Ferrand ....	Bevel gearing .....	4-4+4-4	57	Ft. In. 9 55	Ft. In. 6 7 10 4	1,600
Paris, Lyons & Mediter....	13,000	25	Pass. and ftr..	....	Anvert-Ferrand ....	Side rods and c. shaft..	2-8-2	..	49 10	.. .. .	2,000
Norfolk & Western.....	11,000	25	Freight .....	1914	Westinghouse .....	Geared c. shaft.....	2-4+4-2	..	52	.. 43 .. 11 .. 4	1,650 at 28 m.p.h.

Road	Traction effort		Max. speed, m.p.h.	Cont. speed, m.p.h.	Type of current converter	Lb. per hr. H. P.	Reference
	Maximum	Continuous					
Paris, Lyons & Mediter....	21,500	17,600	..	37	Permutator .....	13.6	Le Genie Civil, Vol. 58, p. 349.
Paris, Lyons & Mediter....	....	28,160	47	26	Permutator .....	17.9†	El. Ry. Jour., Vol. 38, p. 386.
Norfolk & Western.....	62,500	33,600	28	14	Phase splitter .....	27.4	El. Ry. Jour., Vol. 42, p. 650.

† 1 hour H. P. tractive effort used.

heating boilers, the average weight might fairly be considered as some 10 lb. per horse power less; still, they would even then weigh much in excess of the European locomotives.

Unfortunately there are insufficient data to be able to determine the average weight per horse power of the split phase or permutator locomotives. They probably will weigh no more than the single-phase ones.

TABLE V

	Lb. wt. per 11.P.	Lb. T. E. available for starting per 100 lb. adhesive wt.
Single phase (American).....	180	21
Single phase (European).....	130	21
Direct current .....	120	27
Three phase .....	100	33
Converter locomotives .....	...	27

It is interesting to compare the latest New York Central direct current locomotive with the latest single-phase Lœtschberg machine. The former has an hourly rating of 2,600 h. p., as compared with the latter's 2,500 h. p. for 1½ hour rating. The weights per horse power are 86 and 95 lb. respectively, the Lœtschberg locomotive being 8 tons heavier in total weight, but with 24 tons less adhesive weight. The length of the New York Central locomotive is slightly in excess of that of the foreign ones.

In column headed Wheel Arrangement, the end figures denote the number of pilot wheels and the other figures give the number of drivers per truck, while the sign + indicates an articulated coupling between trucks. The reference given in the last column contains most of the tabulated data and at the same time gives a more detailed account of the construction and control.

### COMBINATION TOOL FOR REPAIRING E-T DISTRIBUTING VALVES

BY F. W. BENTLEY, JR.

In the hurry of air brake running repair work there is one aggravating feature in connection with the removal of cover screws from the application portion of the distributing valve. The distributing valve on many of the larger locomotives is located so close to the reverse lever fulcrum casting that it is impossible to work with a screw driver on the cover screws. While the screws may be reached with the driver, the necessarily

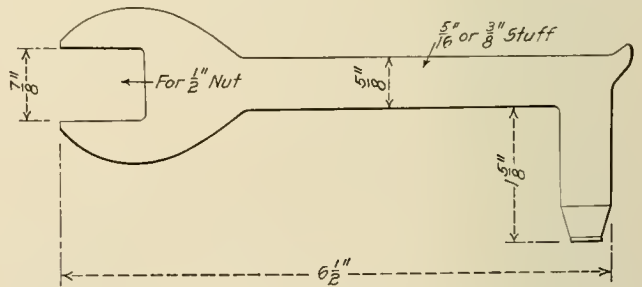

Combination Wrench and Screw Driver for Use on Distributing Valves

tipped position of the tool prevents the application of any great amount of force, and at the same time will quickly ruin the head of the screw.

The drawing shows a combination wrench and screw driver which has been used with considerable success. The nature of the driver end permits the application of a direct turning force to the head of the screw without damaging it, as the shank of the driver can be held down in the head slot. The handle end comprises a ½ in. wrench for use on the bolts of the application piston and equalizing heads. The wrench is easily blocked out and forged, and will be found very useful in connection with hurried work on the distributing valve.

# PENNSYLVANIA STEEL BOX CAR

Wood Is Used for the Floor and Lining and the Roof Sheets Are Spot Welded to the Carlines

Following along the lines of eventually having all of its freight cars of the all-steel type, a car, the framing of which can be used practically without change for either box, stock or refrigerator cars was designed in the mechanical engineer's office of the Pennsylvania Railroad in 1912 and a large number of them

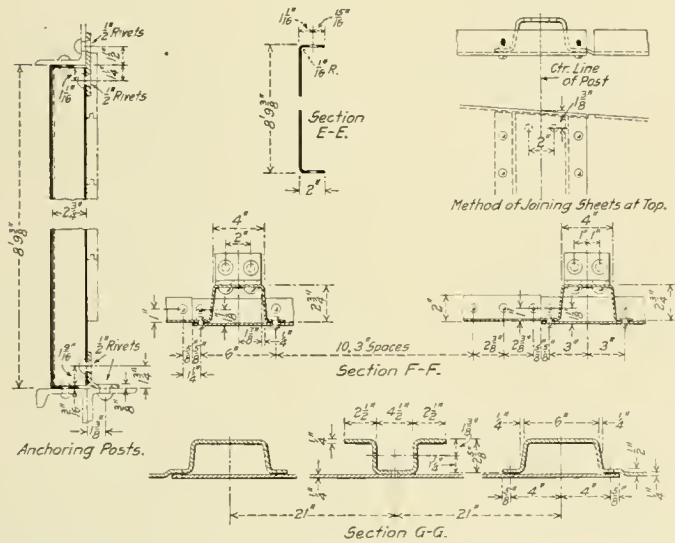

Structural Details; the References Are to the General Arrangement Drawing

have since been built.\* The most recent design of box car on the Pennsylvania, which is designated as class X 25, is constructed entirely of steel with the exception of a wooden floor and  $\frac{7}{8}$  in. wooden lining. This car, when mounted on arch bar trucks with  $5\frac{1}{2}$  in. by 10 in. journals, weighs 49,100 lbs.†

\*For description of these cars see *American Engineer*, October, 1912, page 502.

†A brief description of this car was published in the *Daily Railway Age Gazette* for June 15, 1914, page 1412.

## UNDERFRAME

The underframe is of the type in which the weight of the superstructure and lading is transferred to the center sills by means of two crossbearers or cantilevers and the end sills. The

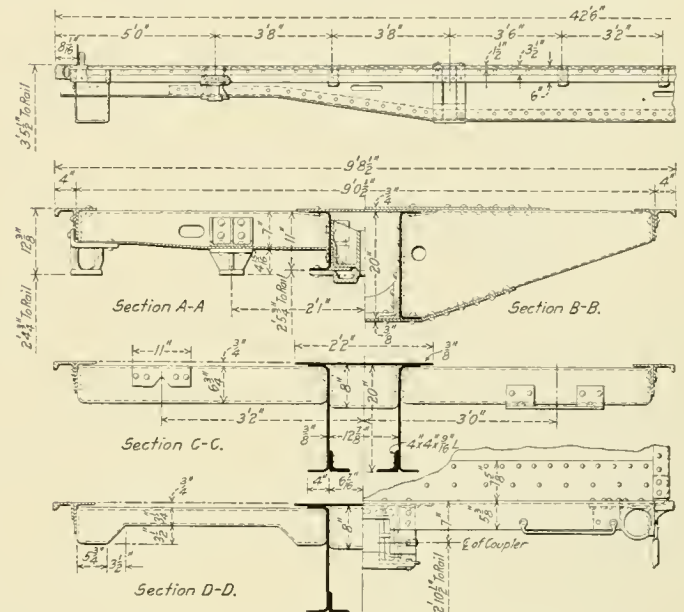

Arrangement of the Underframe and Details

center girder has a minimum section area between the rear follower stops of 34 sq. in. and is built up of two  $\frac{3}{8}$  in. fish belly type pressed U or channel shaped sections, 20 in. deep between the crossbearers and with 4 in. flanges top and bottom, the channels being spaced 12 $\frac{7}{8}$  in. back to back and tapering to 11 in. at a point 22 $\frac{11}{16}$  in. back of the center plate. There is a  $\frac{3}{8}$  in. by 26 in. top cover plate riveted the full length of the center sills,



Steel Box Car for the Pennsylvania









the crossbearer flanges. The crossbearers are riveted to the center sill and the bottom member of the side truss.

The body bolster is composed of a diaphragm  $\frac{3}{8}$  in. thick, 7 in. deep,  $7\frac{3}{8}$  in. between vertical walls and riveted to the center sills and side truss. This member has to take care of the side bearing thrust only and does not carry any of the load. Above the side bearing, which is a steel casting, is a cast steel reinforcing block, and at the extreme end is a combined roping iron and jacking casting. The drop forged center plate is secured to the flanges of the center sills, as well as the center plate reinforcing casting, which extends back towards the center of the car 9 in. from the center line of the center plate, and reinforces the center sills.

There are six intermediate diaphragms on either side of the car, four of which are located between the crossbearers and one

tion. The end sill is secured to the striking plate and at either end to a cast steel push-pole pocket and corner casting, which are in turn riveted together and secured to the bottom member of the side truss and to the diagonal brace, while the top vertical leg of the end sill is riveted to the end sheets the entire width of the car.

The diagonal braces are of U shaped section, 8 in. wide and  $\frac{3}{8}$  in. thick, with  $2\frac{1}{2}$  in. flanges pointing downward. They are flattened at both ends, being fastened to the top flange of the center sills at one end and to the push-pole pocket and the bottom member of the side truss at the other end.

The side sill, or bottom member of the side truss, runs continuously between the end sills and is composed of a 4 in. by 6 in. by  $\frac{3}{8}$  in. angle and a 4 in. by  $3\frac{1}{2}$  in. by  $\frac{3}{8}$  in. bulb angle, which are riveted together back to back. The short leg of the

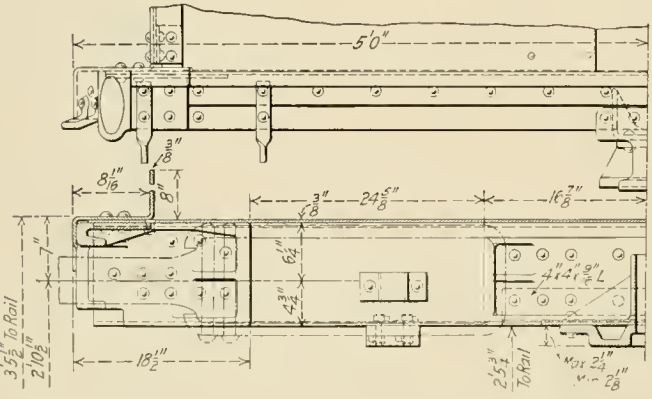
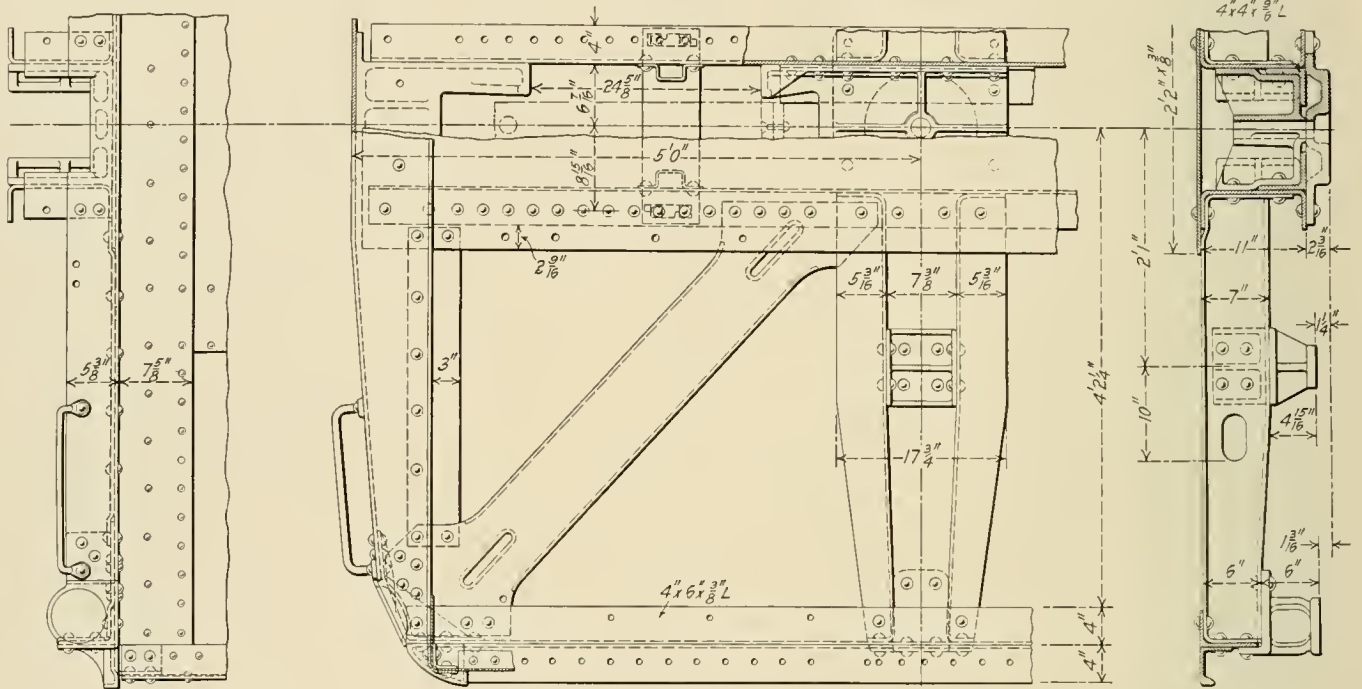

Arrangement of the End Sill and Corner Construction

midway between the crossbearer and body bolster at either end of the car. They are  $6\frac{3}{4}$  in. deep and  $\frac{3}{8}$  in. thick and do not carry any of the load, as their top flanges are  $\frac{3}{4}$  in. below the bottom of the floor, but simply act as stiffeners for the bottom member of the side truss, and as supports for the brake rigging.

The end sill consists of a Z shaped plate  $\frac{3}{8}$  in. in thickness, which extends the entire width of the car, binding the side and end construction together. It is 5 in. below the top of the center sills and is flanged inward for a distance of  $8\frac{7}{16}$  in. at the center, narrowing somewhat toward either side. The back vertical leg, which is 8 in. high, forms a connection for the end construc-

tion. The end sill is secured to the striking plate and at either end to a cast steel push-pole pocket and corner casting, which are in turn riveted together and secured to the bottom member of the side truss and to the diagonal brace, while the top vertical leg of the end sill is riveted to the end sheets the entire width of the car.

SUPERSTRUCTURE

In designing this car efforts were made to provide as great a protection as possible for the lading in case of accident or rough usage, and to reduce, as far as possible, the number of parts. The superstructure was designed with an outside shell composed of a series of  $\frac{1}{8}$  in. sheets for the side, and  $\frac{1}{4}$  in. sheets for the ends, in which the posts are pressed integral. A U shaped post is pressed into one end of each sheet and is overlapped by the adjacent sheet, which acts as a cover plate for the post and gives a smooth surface on the outside of the car. The post portion of the sheet is  $2\frac{3}{4}$  in. deep and 4 in. wide at the back. The sides of the car are composed of ten sheets each, which have a 2 in. flange, top and bottom, by means of which they are secured to the bulb angle of the side sill and to the 6 in. by 4 in. by  $\frac{3}{8}$  in. eave angle or side plate at the top.

The end construction is similar to that of the sides, each end being composed of three sheets, the two nearest the sides of the car containing the depression which forms the post. Where the central sheet overlaps these, they are depressed  $\frac{1}{4}$  in., making the outside face perfectly smooth so that it may fit down snugly behind the end sill. The middle sheet has an additional U shape stiffener at the center,  $2\frac{5}{8}$  in. deep,  $9\frac{1}{2}$  in. wide and  $\frac{1}{4}$  in. thick, extending vertically from the end sill to the eave angle. The side

door posts are made up of 4 in. by 3½ in. by ⅜ in. bulb angles.

The side and end sheets are tied together by a cover plate, L-shape in section and ¼ in. thick. This is capped top and bottom by suitable castings, which finish off the corners, and at the same time act as a connection between the side and eave angles and the side and end sills. To the side and end sheets, midway

eave angles are 3/16 in. washers, through which the rivets are driven. This construction allows for a slight ventilation and yet is small enough to keep out anything which might cause damage to the lading. The roof sheets are fastened together by an outside and inside strip, the outside strip being 2½ in. wide and 3/32 in. thick and pressed up in the center 7/8 in., which adds to the stiffness of the structure. The inside strip is 2½ in. wide and 3/16 in. thick. These strips are continuous across the car and are riveted to the roof sheets with ¼ in. rivets spaced 1½ in. apart. To insure a perfectly water-tight joint, tar paper is placed between the outside butt strip and the roof sheets. The end and side eave construction is the same, except that there is no ventilation at the end.

The 13/16 in. pine inside lining is nailed to vertical nailing strips, conveniently spaced around the sides and ends. The lining extends to within 3 in. of the floor. There is an air space back of the lining which allows for ventilation, and also facilitates cleaning. The application of a triangular grain strip around the edge of the floor, next to the side sheets, allows all foreign matter to work its way out from behind the lining.

A new feature in this car is the manner in which the safety

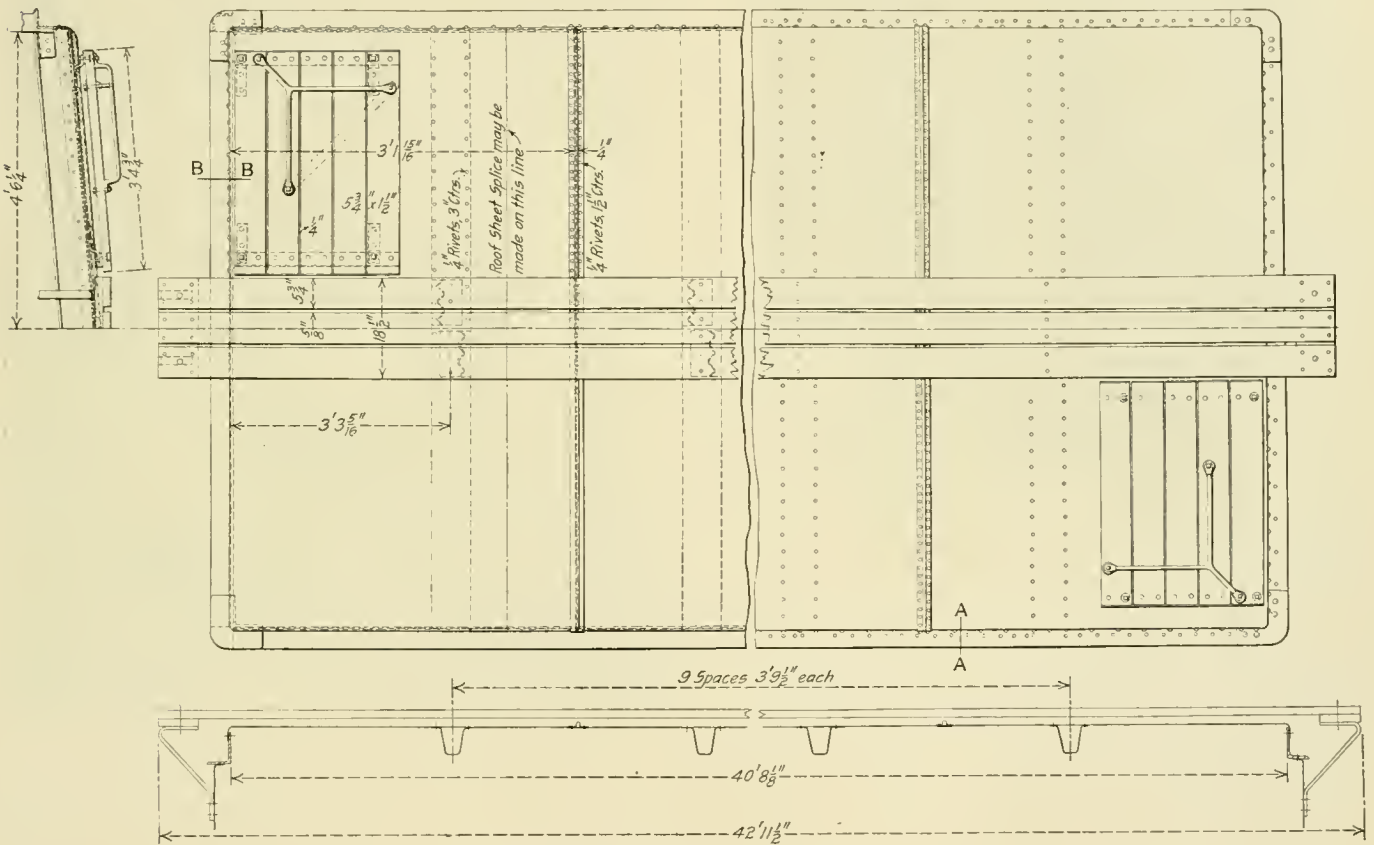
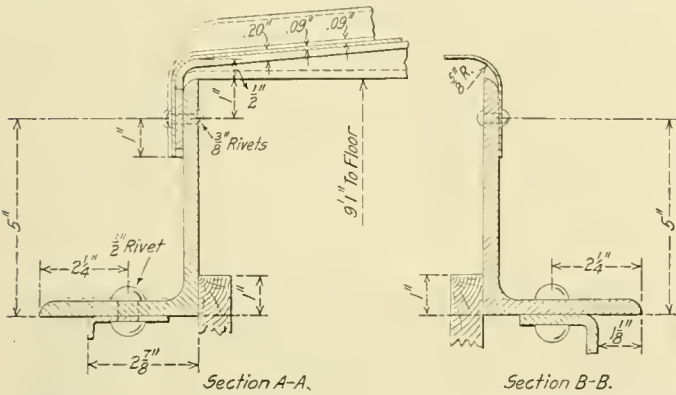

Arrangement and Details of the Roof

between the posts, vertical nailing strips are secured, to which the lining is nailed in a horizontal position.

The carlines are of the bathtub or U type, being spaced 3 ft. 9½ in. apart, resting on the 6 in. vertical leg of the side eave angle and extending downward from the side a sufficient distance to be securely riveted. The 3/32 in. steel roof sheets are continuous across the car, being spot welded to the carlines, which are located in their center. This allows the butt joint to come midway between the carlines, with the exception of the end roof sheets, which, because of the position of the last carline, must cover one and one-half spaces.

The roof sheets are flanged down on the vertical leg of the side and end eave angles 2½ in. and are secured to them by ⅜ in. rivets spaced 4¾ in. apart. Between the roof sheets and the

appliances are secured. All grab irons are fastened to castings by means of a slotted hole in the face, which permits the removal of the grab iron bolt, and thus the renewal of the grab irons without disturbing the inside lining. A like provision is made for the side door stop.

DOORS

The car is equipped with outside hung doors, supported at the top by hangers at both corners. A 5 in. by 1¾ in. by 5/16 in. angle acts as a top guide rail and weather strip, the short leg being turned down over the face of the door. The door is made of .109 open hearth steel, with two vertical Z-shaped edge stiffeners, which are flattened out, top and bottom, supporting the door hanger and door guide castings. The rear stiffener laps



over the door post, and the front one butts against a 2 in. by 2 in. by 1/4 in. angle riveted to the side sheets and projecting slightly beyond the door, thus forming a weather strip, front and back. There are two horizontal U-shaped sections pressed in the end of the top and intermediate door sheets, which overlap the adjacent sheets, forming a stiffener across the door. At the bottom of the door is a 1 3/4 in. by 1 3/4 in. by 1/4 in. stiffening angle, which runs continuously between the vertical stiffeners. The inside of the door is perfectly smooth, all rivets being countersunk. A clearance of 1/16 in. is allowed for the door to clear



End View of the Pennsylvania Steel Box Car

the door post. The floor is extended through the door opening, flush with the door post, and is supported by the bulb angle of the side sill.

The following are the leading dimensions and data:

Length over end sills.....	42 ft. 6 in.
Inside length .....	40 ft. 5 in.
Inside width .....	8 ft. 10 in.
Inside height .....	9 ft. 1 in.
Height top of rail to top of floor.....	3 ft. 7 1/2 in.
Height at eaves .....	12 ft. 10 in.
Width at eaves.....	9 ft. 2 in.
Capacity .....	100,000 lb.
Cubical capacity .....	2,343 cu. ft.
Weight .....	49,100 lb.

PEAT IN RUSSIA.—Some further efforts are about to be made to develop the peat resources of Russia. The state is very largely interested in the subject, as it owns large areas of peat land, the full resources of which are but imperfectly known.—*The Engineer.*

ELECTRIFICATION IN GERMANY.—The trials of multiple-unit trains on the Laudan-Konigszelt mountain railways in Silesia, Germany, have proved very satisfactory, and the service is to be extended to Fellshammer, and shortly to the Austrian frontier, at Halbstaedt, a total distance of 21.7 miles. The full electrical service will be put into operation before the end of the year, and the working of through trains by locomotives will commence during the summer.—*The Engineer.*

## TOOL CABINET FOR THE MACHINE SHOP

BY C. E. PADDOCK

The photograph shows a tool cabinet used in the Springfield, Mo., shops of the St. Louis & San Francisco. It is designed for use with large machines requiring many tools, such as boring mills and planers. The top consists of four shelves made of No. 16 iron, the back of each shelf being bent up 3/4 in. to prevent tools from being pushed through, while 1/2 in. of the front is turned downward, thus increasing the rigidity of the shelf. A variation of width between shelves is made to allow for different size tools. The light through these spaces makes the selection of tools easy and simplifies the blowing out of dust. Between the lower shelf and the top of the cabinet is a 6 in. space, which is deep enough to make the entire top of the cabinet available as a table. The drawer is for operator's small personal tools and



Steel Tool Cabinet for Use with Boring Mill

the spaces beneath and to the right may be used for larger tools, blue prints, etc. The door which closes this part of the cabinet swings downward and forms a resting place for set calipers and working drawings. The lower half of the cabinet may be used for clamps, bolts and blocks. Underneath is room for mandrels and various other tools not in constant use. On the right hand end is a shelf for holding small boring bars, sockets and the table center. On the left hand end of the cabinet are hangers which hold a set of wrenches, and hardened gages for all classes of work done on the machine, which are kept at every one's service and are never locked up.

For small machines a narrower cabinet is used which is simply provided with a small drawer and is without shelves or the door in front. Such machines as wheel lathes and planers use the larger type of cabinet without the top shelving. For use with drill presses the smaller cabinet is built with conveniently arranged shelving for holding drills, which the operator may keep locked up.

# TOOL FOREMEN'S ASSOCIATION

## Reports on the Standardizing of Reamers, Special Tools, Grinding, Dies, and Tool Distribution

The sixth annual convention of the American Railway Tool Foremen's Association was held at the Hotel Sherman, Chicago, July 20-22, inclusive. The meeting was called to order by A. M. Roberts of the Bessemer & Lake Erie, president of the association. After a prayer by the Rev. Howard A. Lepper, rector of Christ Church, Englewood, the association was welcomed by J. F. De Voy, assistant superintendent motive power and machinery, Chicago, Milwaukee & St. Paul. Mr. De Voy spoke very highly of the work done by mechanical department associations, stating that the members in attendance at the Atlantic City conventions this year seemed to pay more official attention to what the junior organizations were doing. Many of the superintendents of motive power in attendance when questioned stated that the time had come when the older associations were becoming more dependent on the junior associations for help in developing the mechanical departments of railways. Money spent by the railroads in sending men to conventions of this kind is not wasted in the least, and if the members will give up their ideas to their fellow workers the railroads will be greatly benefited.

Mr. De Voy paid special tribute to the integrity and sincerity of purpose of the men in the motive power department. Conventions of this sort will do a great deal to promote the general efficiency of that department. He referred to the tool foremen as efficiency engineers of the highest type and pointed out that their special field lay in establishing standards that would facilitate the work and reduce the cost of production, referring to the work done in the automobile industry as an example.

A special field for the tool foremen is the devising of safety appliances to be placed on machines. By their ingenuity they can devise efficient and inexpensive safeguards that will be of vast benefit to the railroads they serve. He called on the tool foremen to shoulder part of the responsibility the state and federal laws have placed on the railroads and do all they can to perfect the safety appliances. Mr. De Voy closed his remarks with some very encouraging words as to the business conditions. Within the past month the Milwaukee has increased its force ten per cent. He laid particular stress on the benefits the railroads would derive from the abundance of grain that is being shipped.

### PRESIDENT'S ADDRESS

President Roberts spoke of the opportunities the tool foremen have in increasing the efficiency of the mechanical department. The higher officers are looking to the tool foremen more and more each year, calling on their ingenuity and skill to increase the output of the shops and at the same time improve the quality of the work. A special field for the tool foremen is to standardize the tools so that a much less number will be required to perform the necessary work. Mr. Roberts also spoke of the benefit he has personally received by attending the conventions. Many new ideas obtained from other members through the discussions on the floor have been successfully applied by him.

### STANDARDIZING REAMERS

C. A. Shaffer, Illinois Central: To any one who has had practical experience in a locomotive repair shop the economy resulting from standardized reamers for the work is obvious, and to those who have gone into the matter systematically no argument is necessary to show wherein the saving may be effected. If conditions would not permit of going into the matter in a general way, possibly on account of not wishing to replace all of the large stock of tools of various descriptions at one time, it may be possible to select one or more sets of reamers to start. A saving in time of from one to eight or ten hours may

be effected on jobs when compared with the old practice of putting the work into a machine and boring it for a fit. Then, too, the life of the job will be much greater if it is done with the proper tools.

A conservative check on the average time being consumed on several operations on a certain job on a large railroad was as follows: Bolting crossheads to face plate on a lathe and re-boring for pin or rod fit, 3 hr. 15 min. to 3 hr. 40 min., as against 20 min. by using a standard reamer. Clamping rod on horizontal boring mill or drill press and truing up knuckle pin hole with a boring bar and cutter, 2 hr. against 15 min. with the reamer. Clamping steam or dry pipe to horizontal boring mill, and truing up joint with bar and cutters, 2 hr. 45 min. against 30 min. with the standard ball joint reamer, which could make the fit with the standard radius.

These are only the initial time-savings, and much more will be realized when it comes to assembling the parts as they may be put together with greater ease and speed. Before making drawings for standard tools one should carefully study their requirements for limitation and dimensions for the various kinds of locomotives handled, and, if possible, anticipating possible new power which the roads may acquire. The commercially manufactured locomotive tapered reamers, which are cataloged by all the leading small tool manufacturers, for use on rods and frame work, come far from being a suitable arrangement for use on the heavy power of today. A revision in standards along this line would, no doubt, result in increased business for the manufacturer and economy for the roads who buy the greater proportion of such tools instead of making them themselves. One of the main advantages in the use of standard reamers is that it admits of greater interchangeability and carrying in stock finished or rough turned parts for immediate application, thereby saving considerable material and a great deal of time in doing the job as well as getting the engine back into service quickly.

E. J. McKernan, Atchison, Topeka & Santa Fe: On the Santa Fe lines all the frame reamers for locomotives have 1/16 in. taper in 12, and I carry the sizes from 1 1/4 in. in diameter, advancing by thirty-seconds of an inch to 2 in. in diameter. All sizes of reamers one inch in diameter and under are purchased from the manufacturer, and all those over are made in the tool room at Topeka. The lengths of the reamers vary from 5 3/8 in. up to and including 17 1/2 in. There is also a set of reamers 28 1/2 in. long ranging from 1 1/8 in. in diameter to 2 in.; they are used in frame work. Nine reamers have been adopted as standard for the crosshead and piston work. These reamers are tapered 1/2 in. in 12 in., and are made with a left hand spiral. Four reamers are used for the knuckle pin work on side rods. They have a 9-in. flute and a 1 1/2-in. taper in 12, with a left hand spiral of 68.57 pitch. For our link blade pins we have a standard tapered reamer with a straight flute 12 in. long. This reamer is tapered 3/4 in. in 12 in., and is 1 1/4 in. at the small end. This one reamer takes care of all the jaws on our Stephenson gears. The standard reamers for saddle flange work are used in all work on cylinder splices, as well as on the flanges for truing up the holes after the cylinder has been bolted. These reamers are 6 in. over all, and have a square shank. They are tapered to 1/16 in. in 12 in. For general motion work two reamers are used, one 17 1/2 in. and the other 19 1/2 in. over all. They have a taper of 1/2 in. in 10 in., for the Walschaert valve gear, and a taper of 3 in. in 12 in. for the Stephenson gear. They measure 1 1/4 in. on the point, and have a left hand spiral of 68.57 pitch.

J. P. Mauger, Philadelphia & Reading, presented blue prints



of the regular line of taper reamers for general repair work. These reamers are made with a straight, heavy pitch flute, with a variation of the pitch from nothing to .016 in. from cutting edge to cutting edge; that is, in milling the flutes .016 in. is gained on the first half of the diameter, and dropped off until it is back to zero. Very little difference was found in the life of the straight and spiral fluted reamers; the straight fluted reamers do the work nicely, and are much cheaper to make.

#### DISCUSSION

A. Meitz, Missouri, Kansas & Texas: In using the rod reamer, I prefer a square shank instead of a taper. We found out that when the reamer closed solid we made the hole a little bit larger on the outside and also on the bottom. If you have a square socket the reamer will make a perfect hole. I make a straight blade reamer and protect the edges by running a left-hand square thread about two to the inch. This protects the cutting edge on the blade as well as keeps the reamer from hugging in. I make these reamers cheaper than milling a spiral flute.

C. A. Shaffer: On some reamers that we made with the square sockets, we left a collar about one-half inch long above the square and put a groove in that collar with two set screws in from each side of the square socket with a ball joint, and we have to bring these set screws into the groove a little bit. It will hold the reamer in the square socket and lift the reamer out.

J. J. Sheehan: Mr. Meitz raised a timely point about the taper fit of the spindle. If the hole isn't true it is liable to force the reamer out. We had that experience and we got around it by making a knuckle socket fitting in a sleeve with a Morse taper fit. That would allow the knuckle to move in either direction. There is just enough movement there to allow the reamer to act freely in the hole, and we have not experienced any trouble. If there was a standard taper for all that work it would simplify the arrangement very much. I think that for all locomotive bolt work the 1/16 taper in 12 is the universal standard.

H. Otto: We cut frame reamers any length and leave 1/32 in. to be milled off. We have a triple head lathe so that we can ream three at a time. We do not have an electric furnace but we temper them in a bath. We heat the steel and harden, then we draw the temper in an oil heated bath. We clamp our reamers to prevent warping, and do not lose more than 2 per cent. An inch reamer 7½ in. long costs shop made \$3.82; a 2 in. reamer 7½ in. long costs \$6.55; a 28½ in. long reamer (I am not much stuck on the long reamers) 15/32 in. in diameter costs \$4.38, and a 1 5/6 in. reamer costs \$6.29.

B. Henrikson: Our reamers have a taper of 1/16 in. per foot. Our large reamers are inserted high speed steel and our small reamers are all high speed steel. We are notching our reamers. I understand that the spiral reamer is better than the notched, but there is more trouble in making them.

Secretary Davis: Do you have any trouble with the high speed reamers being brittle or breaking? Do they break many of them from side strains?

Mr. Henrikson: Yes, they do, but I find that is due to the temper.

O. W. Kinzie: I prefer the spiral reamer over the straight reamer, and I am positive that the spiral reamer is much more efficient. We are putting in less teeth and we get good results. In the year's time that we have had this set of frame reamers and rod reamers in use, I do not believe I have found one broken out of the full set. We make our reamers mostly 1/16 in. taper in 12 in. We use carbon steel altogether for these reamers and we have never had any trouble about the motors being too fast for the reamer, especially the heavy reamer. For bridge reamers, such as the boilermakers use, we have to use high speed steel. The machine work on the spiral reamer is practically the same. We mill our spiral reamers with a triple head device. I admit there is more trouble in keeping the spiral reamer straight, for

the reason that you cannot clamp them, but we have not had any trouble to complain of. I think the advantages of the spiral reamers are so greatly superior to the straight reamers that it pays in the end to make the spiral reamer. We harden in the electric furnace. The spiral of the reamers would be about ¼ of a turn, the length of the reamer.

W. C. Stephenson: On the Atlantic Coast Line we tested nine reamers up to 1½ in. We had nine high speed and nine carbon, and we milled them with 5 flute and 8 deg. We milled some 5 flutes and 12 deg., and we found that the one with 8 deg. gave better results. We turned them down from the little end for 1 in. with a 1¾ in. taper; the other part of the taper is 1/16 in. to the foot and we milled them spiral left hand. We use carbon steel and get very near the results on the carbon that we do on the high speed, but I believe in high speed reamers provided you get the right degree spiral and get them tempered right. If you get the right spiral on them they won't feed too fast. We do most of our work with large reamers by hand.

E. H. Whittier: All our reamers we make with a square shank. We are using air motors, or a drill press. The photograph shows the joint socket. There is oscillation enough in the socket. We have a set of little collars that have the square shanks. I find they give perfect satisfaction.

A. R. Davis: We have adopted three tapers to cover all work

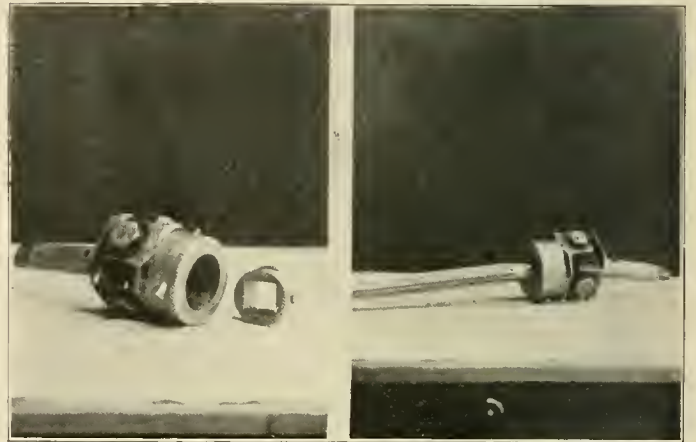

Jointed Socket for Handling Square Shank Reamers

outside of our regular bolts. All single fits on motion work which concern the rocker arm pins, transmission bar pins and all pins of that class have ¼ in. in 12; all double fits or jaw of the transmission bar, the plates have ⅝ in.; all of the piston rods, both ends are ⅝ in.; then all of the rod fits calling for a heavier taper are 1¼ in.

E. V. Nabell: Our experience has been that the cataloged reamers are too short. The average reamers are too short with the Mikado type engines.

W. C. Stephenson: Everybody carries reamers from ¼ in. up for odd jobs: I grind 1/32 in. off each time it is necessary to grind a reamer and mill the flute so that I can grind it about 4 times; then we have to mill it. When high speed reamers give out we turn them down. We do not scrap any high speed at all. We reclaim everything.

G. W. Smith: We have reamers 12 in., 17 in. and 27 in. long, and that covers the ground pretty thoroughly, especially the heavier power that has been introduced of late years which require the long reamers 27 in. I never have any trouble in regard to reaming as long as we use these sockets on the square shanks. It doesn't make any difference how long the hole is on any drill press or any air motor; it can adjust itself.

President Roberts: We have recently adopted the 1/16 taper for all frame bolts, smoke arch bolts, rod bolts, stretcher pins and all truck bolts. In the reach rods we use ¼ in. taper; in angle pins ½ in. taper; ½ in. crosshead pins and ½ in. in piston fits.

All of those reamers are square-headed. For the frame reamers where we use air motors we simply have a short square shank about  $2\frac{1}{2}$  in. long. The end of that shank fits the motor and the other end where the reamer fits in is made of various sizes. I find that the regular commercial reamers are almost invariably too short. We use quite a number of reamers 26 in. long of various sizes, and we use lots of 16 in. reamers. We have also the 14 in. reamer, while the commercial reamer comes to about 10 in. We buy all high speed steel reamers. We have lots of trouble with the carbon reamers in regard to durability.

[The secretary was instructed to obtain from the members of the association their requirements for reamers with a view of adopting standard reamers at the next convention.]

### TOOL ROOM GRINDING

W. C. Diebert, Chesapeake & Ohio: A great deal of difficulty is experienced in grinding tools where there are no automatic machines. Among the special tools for grinding made at Clifton Forge, Va., are a surface grinder, an automatic reamer grinder, a small die grinder and a grinder for cutting the cutters for the Ingersoll milling machine. This latter grinder will cut up to 14 in. in diameter, and grind the radius on the cutters for those used in channeling out driving rods. The wheel lathe tools are given an angle clearance of 7 deg. and a 10-in. by  $1\frac{1}{2}$ -in. hard wheel is used for grinding them. By using a template on them from time to time a very good job may be obtained. All the special taps that must be backed out are given about 2 deg. clearance, while those that are driven all the way through are given a little more.

The bolt cutter dies are ground to an angle of 25 deg., and a wheel one-eighth larger than the bolt is used to grind the clearance. It has been found that the throat of the Lassiter stay-bolt machine dies must be made just right as otherwise the head would not be heavy enough to start them. An angle of 25 deg. has worked very well.

J. C. Bevelle, El Paso & Southwestern: The tools that are issued from the tool room on check are all ground in the tool room. The two cutting edges of drills should be at an angle of 59 deg. for ordinary purposes. The angle of lip clearance should be about 12 deg. This angle, however, should gradually increase as the center of the drill is approached until the line across the center of the web stands at an angle with the cutting edges of 135 deg. For a heavy cut in soft material the angle of lip clearance may be increased to 15 deg. The failure to give sufficient angle of lip clearance at the center of the drill is the principal cause of splitting drills up the web. We use a No. 30 grain wheel with very satisfactory results.

Standard reamers should be kept properly ground and sharp, as otherwise a great deal of time will be consumed or wasted by the man who is using them. In the shop at El Paso, Tex., the reamers are not placed in the rack until they have been inspected and put in first class condition. The bolt or frame reamers used in that shop are ground with as large a wheel as possible, so that they will not be hollow-ground. The clearance of the reamers and such tools is determined by the use of an external cylindrical gage the corresponding size of the reamer. A reamer's proper clearance is 3 deg.; any more will allow it to chatter and ream the hole out of round and dull it quickly. All taps are ground on the face of the flute just enough to renew the edge of the teeth, and precaution must be taken in keeping the face of the flute in line with the center of the tap. The points of the taps are ground with a relief of about 3 deg. In grinding milling cutters the teeth are sharpened on a cutter grinder, using the finger of the machine as a means for obtaining the proper clearance, which is about 3 deg. Formed milling cutters are always ground on the face so as to retain their shape, and care should be taken in keeping a formed cutter, more especially a gear cutter, sharp at all times. Peg milling cutters are ground in the same manner. A groove is milled between each row of the cutters about  $\frac{3}{16}$  in. wide and

$\frac{1}{16}$  in. deep, so that the finger may serve as a guide. Disc flue cutter used for grinding off boiler flues are also ground to renew their cutting edge.

Standard bolt dies that are used in bolt-threading machines are ground at the throat with a wheel about  $\frac{1}{4}$  in. larger than the bolt which they are to cut. The heavy roughing tools that are used on wheel lathes for turning tires are ground to the following angles: Clearance angle, 6 deg.; back slope, 8 deg.; side slope, 14 deg. This allows a very fast speed. The finishing tools used for tire turning have a clearance of 6 deg., with a back slope of 8 deg.

Owen D. Kinsey, Burnside shops, Illinois Central: Our grinding machinery is placed as far away from precision machinery as possible to avoid trouble from dust, and in a position to command good light and ventilation. The spindles of all the grinding machines have been made standard so that the grinding wheels may be interchanged. Instructions have been posted on each machine showing the belt position for wheels of different diameters. Success or failure in grinding operations depends directly on the proper selection of wheels for the particular work in hand. We have found that a cool, free cutting wheel is the most economical in the long run even though the wheel life is shorter. The heaviest cutters we handle at present are 10 in. by 20 in. peg cutters. These cutters are ground on a Bath Universal grinder using a radius arm projecting from an arbor upon which the cover is mounted. This arm travels on a fixture mounted on the side of the machine, and produces a helical curve permitting the grinding of the cutting faces of the peg. The cutter is then revolved, and the teeth are ground to an even length, after which the clearance angle is ground.

Thomas F. Eaton, Baltimore & Ohio: There are 70 wheels in service at the Baltimore shops, and it has been found expedient to have one man inspect all the wheels throughout the plant rather than have each department look after their own. By this means I am kept posted as to the condition of the wheel, and we are enabled to keep the wheels in a safe and efficient running condition. For rough grinding wheels No. 24 grain wheels with a medium soft bond are used, and for the Universal tool grinders on finished tools a No. 60 grain wheel is used. An apprentice operates one Universal tool grinding machine, which handles plain reamers and shanks and tangs.

### DISCUSSION

The principal point of discussion on this subject was the grinding of high speed steel. Many of the members reported poor success with grinding high speed steel wet, as it had been found that the steel would split and chip, due to uneven heating and cooling, and for that reason they have been grinding this grade of steel dry. It was pointed out, however, that the probable trouble was that when grinding wet care was not taken to see that the metal did not get overheated, whereas grinding dry more care would be taken. Some members found the spiral reamers so difficult to grind that they have not made many on that account. It was clearly brought out that with broken and dull tools good work could not be expected, and the moral effect on the workmen would be such as to make him discontented and greatly decrease his efficiency. Dull tools will also waste a great deal of power in machine tools. The grinding wheels should be kept in good condition, and should be made the job of one man, so it would be possible to hold him responsible for it. In grinding slab millers very good results will be obtained, not only from the life of the miller, but from the work performed, if the wire edge is taken off before it is given out to the workmen. Special care must be taken in using the right kind of abrasive wheel for grinding.

In the discussion the members digressed a little, and spoke of welding high speed steel to carbon steel bodies. Some members did not have very good success as the heat of the welding would draw the temper of the tool and not give good results. However, this has been overcome by brazing the shanks on



by the oxy-acetylene process. Electric welding was deemed to be more satisfactory, as it would localize the heat more, and thus would not heat up the tool as a whole too much. Instances were mentioned where high speed steel tips of about one inch material were welded on carbon steel bodies, both parts being heated to a definite temperature so as to prevent undue strain. These have given very good results, and were recommended by the members using them. One member reported that 27 to 30 pairs of wheels were turned with lathe tools thus made, at a speed of 28 ft. per minute. The high speed steel part of the tool weighed only about 8 oz.

#### SAFETY APPLIED TO GRINDING WHEELS

The following is from an address by R. G. Williams, safety engineer, Norton Company, Worcester, Mass.:

In view of the fact that grinding wheels are operated at such speeds that the cutting surface travels approximately a mile a minute, due precaution should be exercised to eliminate, as far as possible, all causes which are known to have been responsible for grinding wheel breakages, and to provide adequate means of protection for men and property if wheels are broken from any cause.

The manufacturers, immediately before packing grinding



Hood Protection for Wheel When Snagging Heavy Castings by Aid of Chain Hoist

wheels, submit them to a speed test in which the wheel is revolved at a speed which subjects it to between three and four times the centrifugal stress it will be subjected to under actual working conditions. Defective wheels break under this test. After completing a test, a record is made of the order number, etc., and each testing sheet is taken before a Justice of the Peace and the man doing the testing work is required to swear that he has made a true record of his work. The manufacturer thus has on file a sworn statement of every test made.

Instances are known where wheels have been sufficiently damaged, after they were tested and before being put to use, to weaken them to such an extent that breakage occurred when the wheels were run at ordinary operating speed. Defects which cause wheels to break thus easily can usually be discovered by tapping the wheel a light blow with a small hammer. If the wheel does not give out a clear ring, it should not be used, but the fact should be promptly reported to the manufacturer.

The design and the condition of grinding machines, as well as the foundation on which they rest, are very important and accidents can often be traced to a failure to realize the importance of one or more of these factors. Machines should be kept in good condition and should rest on a firm foundation. Machines used

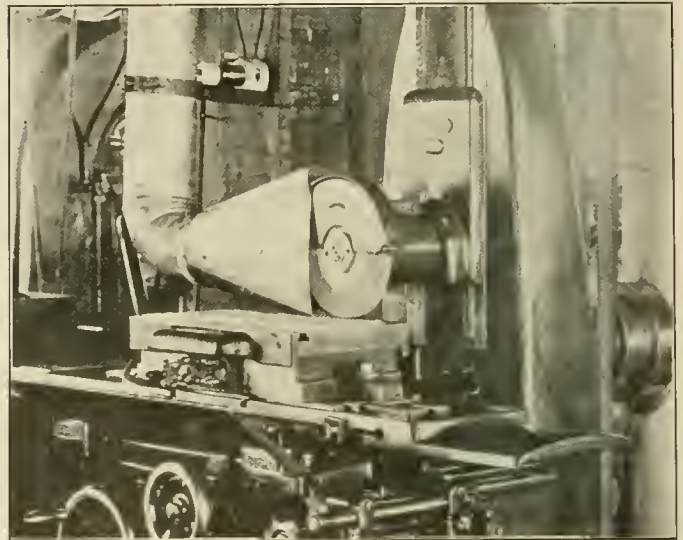

Surface Grinder Connected with Dust System; Wheel Protected by Hood

for rough work, such as snagging castings, are subject to severe abuse and are seldom kept in good condition. Statistics show that a large majority of grinding wheel accidents occur in foundries, thus emphasizing the importance of the above points.

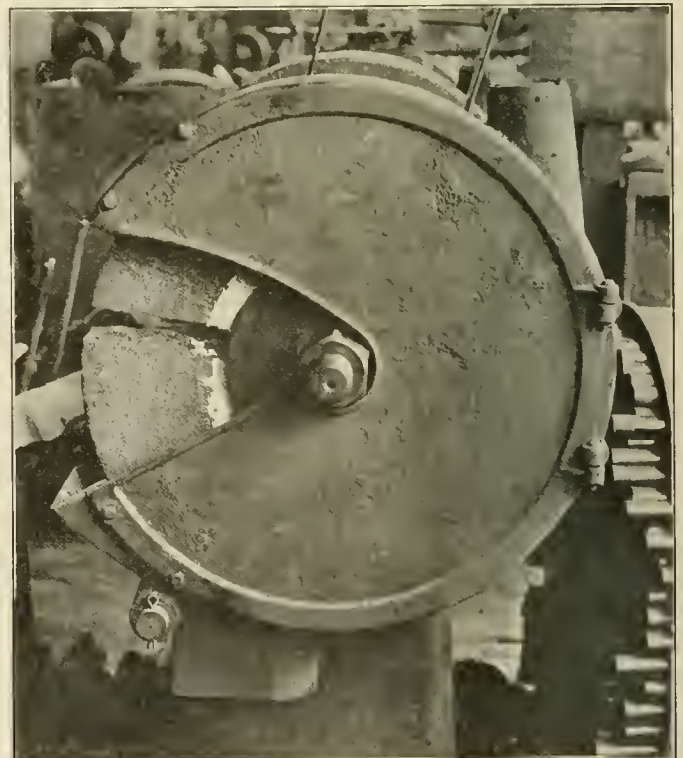

An Efficient Type of Hood for a Floor Stand

#### GRINDING WHEEL BREAKAGES

Grinding wheel breakages may be caused by the wheel receiving a blow on the side, by improper adjustment of the work rest, by the heating of the wheel from forcing of the work, by the careless handling of heavy work, by the mounting of the wheel

with flanges of unequal size, by uneven bearing of the flanges on the wheel, by the wheel running out of true, by the inside flange being loose on the spindle, by the hole in the wheel being too tight a fit on the spindle, by the use of straight instead of relieved flanges, by excessive tightening of the nut, by the use of washers that are too small or by none at all being used, by the overheating of the spindle, by the wheel running too fast or by mounting the

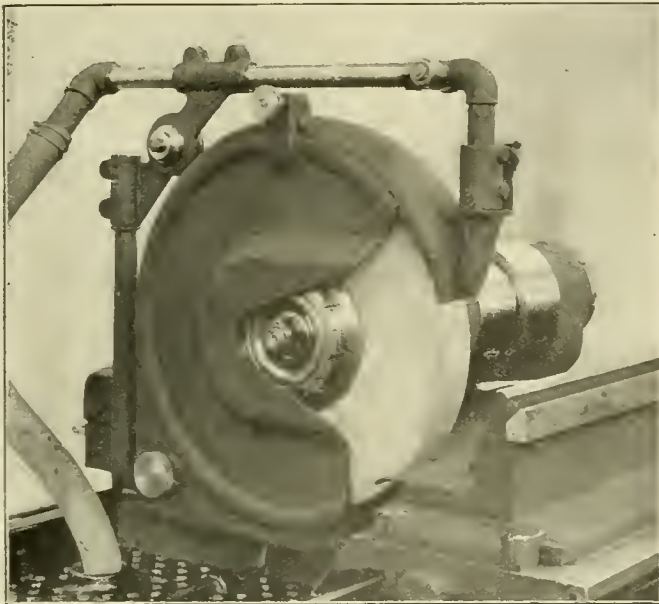

Hood on Norton Cylindrical Grinding Machine

wheel so that the nut works loose. Care should be taken to properly adjust machine parts so that there is not sufficient space between them and the wheel to allow the work to become caught. The work rest should be adjusted as closely as possible to the grinding wheel, as breakage may be caused from something dropping between the rest and the wheel.

Instances are known where breakage was the result of the

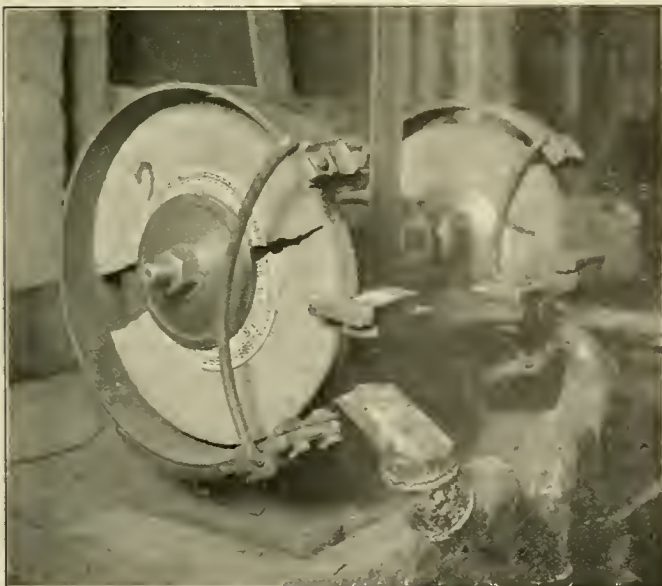

Wheel Broken from Excessive Heat Generated in Grinding

grinding surface of the wheel becoming very much heated. Usually the direct cause for such breakages is the fact that the wheel becomes glazed so that excessive pressure is necessary to keep up production. The remedy is to keep the wheel sharp or obtain a wheel better suited for the operation in question.

Serious accidents have happened where large castings are ground while suspended by means of a chain hoist and through carelessness the castings are allowed to strike against the wheel.

A cause of wheels running out of true is directly traceable to lack of proper attention to the machine bearings. The bearings become highly heated, the bearing metal flows, a heavy brake action is produced on the spindle and when the machine is stopped the momentum of the grinding wheel is sufficient to loosen the mounting. When the wheel is started again, the nut will not automatically tighten and the wheel will be running under dangerous conditions.

Wheels should not be allowed to remain partly submerged in water, because they will be badly out of balance when started. Some people seem to believe that water has a detrimental effect on grinding wheels. This is not true for the modern grinding wheels; even those bonded by means of silicate bonds, are made water-proof.

The inside flange should either be keyed or pressed on the spindle. Accidents have been known to result from the work being rubbed against a loose inside flange, thus exerting a brake action on the flange, which in turn causes the nut on the spindle to crawl, and in this way enough pressure is exerted on the wheel by the flanges to crush the structure of the wheel.

By the excessive tightening of the nut, sufficient pressure can be set up between the wheel and the flanges to crush the struc-

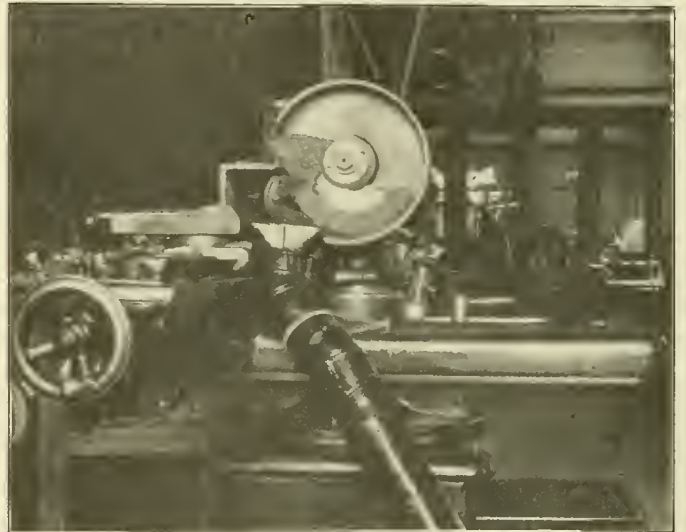

Cast Steel Protection Hood Adapted to Tool Cutter and Grinding Machine

ture of the wheel. It has been calculated that where the spindle is 1 1/2 in. in diameter, a man with a 4 ft. wrench can exert a pressure between the wheel and the flanges of over a ton and a half.

Washers of blotting paper or some other compressible medium should be used between the wheels and the flanges. These tend to distribute the stresses set up when the flanges are tightened against the sides of the wheel. They should be somewhat larger than the flanges.

Polishing stands are sometimes used for rough snagging work with wheels which are much too heavy for this type of machine. Bench and floor types of grinding machines are usually designated by the size of the spindle where the wheel is mounted. It is therefore, common practice to designate the maximum size wheel to be used on any machine by tabulating spindle sizes and wheel sizes as follows:

Size of spindle	Diameter and thickness of wheel	Size of spindle	Diameter and thickness of wheel
1/2 in.	4 in. x 1/2 in.	1 1/4 in.	14 in. x 2 1/2 in.
5/8 in.	6 in. x 7/8 in.	1 1/2 in.	16 in. x 3 in.
3/4 in.	7 in. x 1 in.	1 3/4 in.	20 in. x 3 1/2 in.
7/8 in.	8 in. x 1 in.	2 in.	24 in. x 4 in.
1 in.	10 in. x 1 1/2 in.	2 1/4 in.	26 in. x 4 in.
1 1/8 in.	12 in. x 2 in.	2 1/2 in.	30 in. x 4 in.

Mounting a wheel so that the nut works loose will cause the



wheel to run badly out of true. This can happen when a machine is taken apart for repairs and the spindle is turned end for end in setting up the machine again; or the motor or shafting which drives the machine may be changed so that it will revolve in the wrong direction; or when putting on a new belt an unreliable workman may use a twisted instead of a straight belt.

#### PROTECTION DEVICES

There are two acknowledged ways of providing protection to an operator in case the grinding wheel breaks while in operation. One is to surround the wheel, as much as operating conditions allow, with a well designed and substantial protection hood; the other is to use what is known as a beveled wheel in connection with flanges of a corresponding bevel. Beveling a wheel causes it to present a wedge shape and the theory is that should the wheel break, the pieces will be retained by the flanges, due to the wheel being thicker at the center than at the point where the outer edges of the flanges bear against the wheel. The large users of grinding wheels were recently consulted with the object in view of finding out which type of protection was being used. A good many replies showed a preference for the protection flange method. This was probably due to the fact that such experience as had been had with protection hoods was with designs which were not heavy enough or were made of weak materials. Unfortunately, there are hoods in use today which would not prove adequate in case of accident.

In order to determine the relative value of an approved type of protection hood and approved beveled steel flanges, breakage tests were conducted under actual working speeds. It was ob-

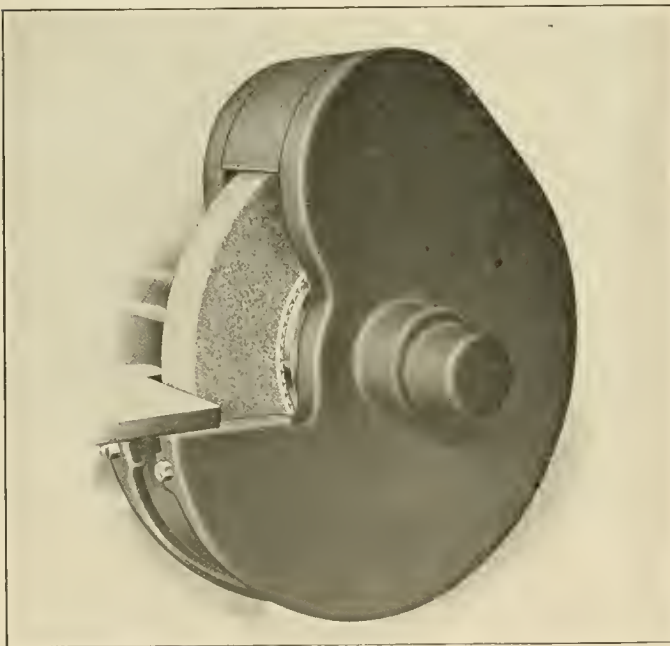

Norton Model D Protection and Dust Hood

served that in none of the hood tests did a piece of the wheel leave the hood in a way that could have caused damage. The tests show conclusively that a well designed protection hood, made of the right material, and properly adjusted, affords ample protection for straight-side wheels even when they are mounted between standard straight relieved flanges one-half the diameter of the wheel. It is possible to break pieces from a wheel by a severe blow when there is only 2 in. of the wheel projecting beyond the flanges. With protection flanges, no matter how little the wheel projects beyond the flanges, an operator has no protection from injury in case a piece of the wheel breaks off outside of the flanges, whereas with a hood protection is almost absolute.

Protection flanges cannot offer complete protection, but in in-

stances where a hood would interfere with the proper use of the wheel, flanges offer the next best method of protection.

#### DUST EXHAUST SYSTEMS

A number of the states have enacted laws requiring the removal of dust from dry grinding and polishing operations. Some of the states have even gone so far as to establish definite specifications for the size of dust exhaust systems, the amount of suction to be maintained in the pipes, etc. While this is a step in the right direction, nevertheless, some of the requirements seem to be unjust in that dust produced by grinding wheels can be satisfactorily removed with smaller pipes and less suction than the laws require. It is essential that the dust exhaust system be kept in proper



Protection Hood, Leather Spark Brush, Gloves, Goggles and Proper Rest Adjustment

repair and that the opening from the hood into the pipe be kept free.

#### GOGGLES AND SPARK SHIELDS

There are several satisfactory designs of goggles for grinding, and every operator doing snagging work should be required to wear them. Since the particles cut off by grinding wheels are comparatively small, a heavy type of goggle is not necessary. Goggles should have side guards of wire or leather as particles coming from one side have been known to enter the eye. A glass spark shield which can be attached to the top of a protection hood is found very satisfactory where wheels are used intermittently. It is recommended that wire glass be used. Glass spark shields have not been found entirely satisfactory where wheels are used continuously, due to the fact that the glass soon becomes pitted from the heated chips of metal.

Another form of protection from grinding wheel sparks is a device consisting of a piece of leather attached to the top end of a protection hood and extending down over the face of the wheel, a slot being cut in the leather the approximate width of the grinding wheel.

#### DRESSERS

Grinding wheel dressers are sometimes the cause of accidents. If the work rest is not properly adjusted there is possibility of the dresser being caught between it and the wheel and the revolving cutters sometimes break into pieces large enough to cause serious damage. A type of dresser is recommended which has a hood as an integral part of the handle, the hood serving to protect

the user in case the cutters break. The ordinary type of dresser can be made more safe by attaching a thick guard of sheet iron over the cutters.

There is great need for the standardization of grinding wheel protection devices. This subject is to be taken up in the near future by the National Council for Industrial Safety and the National Machine Tool Builders' Association. These two organizations will consider all the important phases of this subject and endeavor to arrive at specifications which can be adopted as standard for protection devices used in connection with grinding wheels.

#### MACHINE TOOL REPAIRS

J. B. Hasty, Atchison, Topeka & Santa Fe: All machines for general repairs are taken to the tool room, dismantled, and all serviceable parts used. Small cast iron gears that require renewal are replaced with steel. Light repairs are made throughout the shop by repair men from the tool room. All repairs and renewals to shop machinery and tools are charged to a separate account, and the different departments are designated by a letter. The machines have serial numbers, and the record is kept as to their location, and the work done on them by the repair department. The classes of repairs are designated by Nos. 1, 2, 3, 4 and 5, according to the amount of work which is done on them.

John Tohill, Buffalo, Rochester & Pittsburgh: To handle the machine repairs, a man should have a broad experience and be thoroughly interested in his work to get the best results. Plenty of shop space should be allotted to this work, and it should be thoroughly equipped with the necessary tools and appliances. Every machine should be given a shop number when purchased, and accurate record kept by the man in charge of machine repairs as to the amount expended on each machine. A full set of catalogs of all tools in service, covering repair parts, should be readily accessible to the repair man so that he can order promptly and anticipate repairs to tools that are wearing fast, thereby causing a minimum delay to the work of the machine. The machine that is broken should be given the proper attention and repaired in a workmanlike manner.

G. W. Smith, Chesapeake & Ohio: Machine tools require a great deal more repairing at the present time than in former years, owing, principally, to the introduction of high speed steel and greatly increased speed. It does not seem to be the upkeep incident to long service any more, but rather the breakage resulting from overstrain in the majority of the cases. In order to overcome this situation we strengthen, wherever it is possible, broken gear wheels, worm wheels, worms and racks with Bessemer steel, and they are stronger than the parts which were previously broken. It is believed to be a serious mistake to operate a machine that is very badly run down. Repairs should have been made before the machine got in this condition. However, it is difficult to get hold of these machines as the shop is so very often rushed that they cannot be spared. In making repair parts of machine tools it is found very economical to keep one or more extra castings or other parts that have been machined, so that they may be used in case of a second breakdown, thereby saving time and getting the machine back into commission much sooner.

#### DISCUSSION

There was some difference of opinion as to whether parts of machines that have failed should be replaced by stronger material than the original parts, but it was believed that in some cases this was perfectly proper. However, care must be taken not to strengthen those parts that will cause some more intricate and expensive part to fail the next time the machine is put under undue strain. It is probably safe to replace broken parts of new machines that are performing the work intended for them by the builders by parts of the same material. In parts that have worn out it may be satisfactory to replace that

part with some material of better quality. Bronze and steel have been found to make the best worm wheel and worm where they were called upon to do heavy duty. Good cast iron case hardened for the worm has also given very good results.

Mr. Shaffer, of the Illinois Central, strongly urged that those men who were responsible for machine repairs keep a cost system, so that it would be possible to estimate the cost of repairing future machines whenever they failed. By this method it will be possible to determine whether it is economical to repair the machine or to buy a brand new machine. Oftentimes it will be found cheaper to make the broken parts in the shop, rather than to wait for a shipment from the manufacturer. At Silvis there are four men under the tool foreman that do all the machine tool repairing, which includes pumps, engines, etc. One man is kept constantly inspecting all the machinery and cranes looking for parts that are unduly worn, and that may be expected to fail, making note of the parts and seeing that duplicate parts are obtained and held in stock in case of failure. This has done a great deal to reduce the loss of time when machines break down.

The life of air motors varies, according to the members, from one and a half years to three years, and it was pointed out that an accurate cost of repairs of each motor should be kept, so that when the repair cost becomes too high new ones can be ordered. All kinds of difficulties were mentioned with keeping strainers in the hammers and motors taken out by the boiler makers. One member reported that he found it cheaper to clean the hammers out than to try and keep the strainers in. However, if the boiler makers can be made responsible for them no trouble should be experienced. On the Texas & Pacific the air motors are given a kerosene bath for four hours every three months, and well lubricated. This practice will give a life of three years at an average expense of only \$10. The air hammers are put in a bath of two-thirds kerosene and one-third signal oil every night as they are turned in.

#### DISTRIBUTION OF SHOP TOOLS

Henry Otto, Atchison, Topeka & Santa Fe: The tool room of a locomotive repair shop is one of the most important, but oftentimes one of the poorest equipped and most neglected departments in the whole shop. In many instances it is located in an out-of-the-way corner, causing the workmen who are in need of tools to waste time going back and forth. In properly planning a tool room it is necessary to consider the distribution and care of small tools, special tools, jigs, air motors and hammers, etc. Large repair shops have, as a rule, a main tool room and one or more tool issuing rooms; also a practical checking system, which must be installed to keep a record of all tools issued. On the Santa Fe a number is assigned to a new man, and he is sent to the tool issuing room where he is furnished with a standard kit of tools according to the department and class of work he is to perform. That man is held responsible for these tools until they are returned, the tool checker keeping an account of the tools furnished, which the workman is supposed to sign. He is then given checks with which to draw other tools. The machine shop men have eight checks, the erecting shop men five checks, boiler shop men ten checks, and all other men five checks. All tools drawn out on check are required to be returned to the tool room on the last working day of each week for inspection. Any one failing to comply with this ruling is reported to the general foreman. If a workman breaks a tool he is required to get a tool-breakage clearance card signed by the department foreman, before he can redeem his check. Lathe, planer and shaper tools, hand drills and soft hammers are replaced without a clearance card from the foreman.

The tool breakage clearance cards are placed on file by the tool checker, and at the close of the month are given to the tool foreman, together with an invoice of the tools on hand in the tool issuing room. The tool foreman checks over the clear-



ance cards, and determines the number of tools to be purchased. The clearance cards are then turned over to the supervisor of tools who makes out a statement which is sent to the superintendent of shops, thereby keeping him fully advised as to the tools damaged.

When an employee leaves the service the department foreman writes an order for the time check. This order is taken to the tool checker, who either approves it or makes a notation of the number of tools or tool checks missing. The workman is charged for each tool that he fails to surrender, the amount being deducted from his pay check. If any of the standard tools in the storehouse run low the supervisor of tools issues an order to the general storekeeper, who, in turn, makes out a shop order to the tool manufacturing department for the tools required.

J. T. Fuhrman, St. Paul, Minn.: The manner of distributing the tools depends upon the size of the shop. In small shops with a small number of men, and a short distance to walk to the tool room, all tools should be kept in one place. In large shops where hundreds of men are working who are divided into gangs conditions may be different. I would suggest a cupboard or locker in every gang to keep wrenches, air hose, etc. Special tools which are only used by certain men may be kept there in charge of the foreman. The arrangement of racks should be given careful attention. All the tools should be classified, and kept in good order.

W. E. Ross, Baltimore & Ohio: The plan of the tool room will be different for different shops, and where necessary department tool rooms should be used. It is believed that the messenger service, if perfected, will give much better results than to have the men call for their tools. The messenger boys are stationed in the tool room, and are called to various parts of the shop by means of an annunciator. All the tools should be given a thorough inspection before they are replaced on the racks.

John W. Nutt, Chicago Great Western: The tool room counter over which the tools are handed out should run the full length or width of the tool room, and should be so arranged as to permit the placing thereon of the tools most frequently called for, such as hand taps, die nuts, stud nuts, gages, etc., so that they shall at all times be accessible to the tool passer. Various other tools may be placed on revolving racks located immediately behind and parallel to the tool room counter, readily accessible to the tool distributor. Each gang foreman on the erecting side of the shop should have a tool cupboard where tools, such as wrenches, hand punches, a set of die nuts, stud nuts, etc., may be kept. These cupboards should be in charge of a tool boy, who will hand out the tools. All motors, air and electric, should be returned to the tool room to be examined and thoroughly oiled at the end of each week, and all air hammers should be returned every evening. No method of handling tools, however good, will operate successfully without the hearty co-operation of department foremen, and their being watchful of the care of tools while in the hands of the men under their jurisdiction. Competent men should be selected to take care of the tool room counter; men who are able to detect an abused tool and make full report of every irregularity.

DISCUSSION

All members were agreed that in order to have a satisfactory tool distributing system the co-operation of all the foremen in the shop must be such that the men will handle the tools properly, and see that they are always returned. All agreed on a definite system for keeping track of all the tools sent out. A little tact on the part of the tool distributor will go a long way in helping the tool foreman out in the matter of lost tools and keeping the tools in good shape.

SPECIAL TOOLS

J. J. Sheehan, Norfolk & Western: In making special tools, every effort should be made to have them as simple as possible, making the simplicity the controlling feature.

Mr. Sheehan presented the following illustrations: Fig. 1 represents a drain cock body and the tool for making it; *A* shows the complete body; *B* the main body of the drill; *C-1* the inserted drill point which drills the lead hole, thus com-

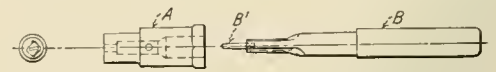

Fig. 1.

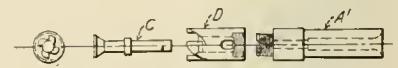

Fig. 2.

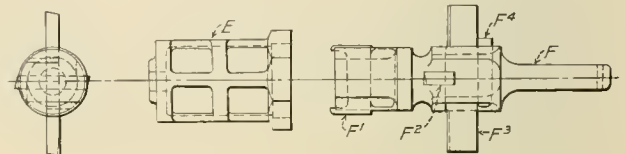

Fig. 3.

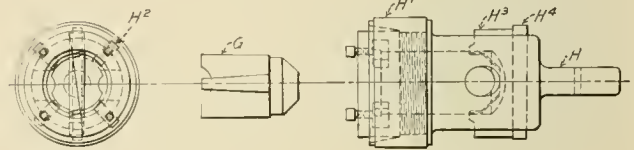

Fig. 4.

Figs. 1, 2, 3 and 4—Tools for Finishing Cylinder Drain Cocks and Relief Valves

pleting the drilling and forming of the valve seat in one operation. Fig. 2 shows the valve for the drain cock body in Fig. 1 and the tool for turning it; *C* is the complete valve; *A-1*

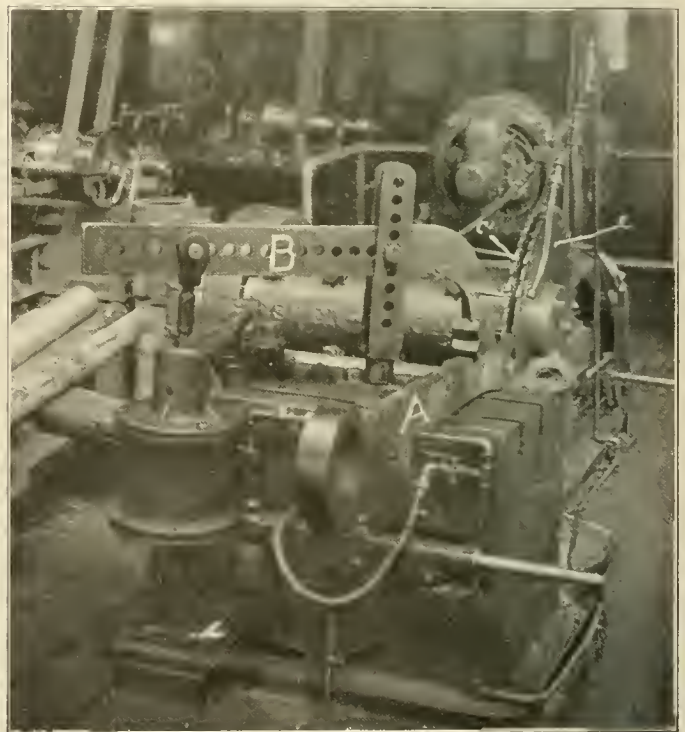

Fig. 5—Cutting Jaws in Locomotive Side Rods

and *D* represent the tool complete. Fig. 3 is the cage for the cylinder head release valve and the tool for finishing it. *E* is the finished part, except for tapping; *F* is a soft steel body holding the forming blades; *F-1* is the leading blade which bores

the body to size; F-2 is a counter boring blade; F-3 is a facing blade, and F-4 is the key that locks the blades in place.

Fig. 4 is a hollow forming tool for turning the valve for the cylinder head relief valve; G is the complete valve; H is the tool holder; H-1 is the adjusting nut for holding blades H-2;

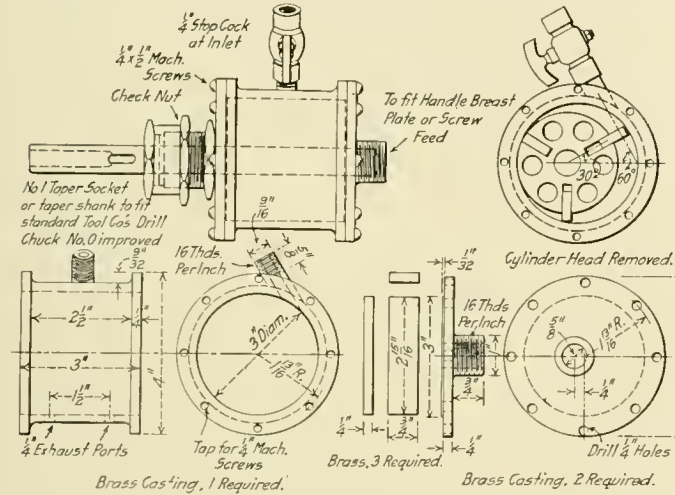

Fig. 6—Air Motor for Light Drilling

H-3 is the seat forming blade held in place by the key H-4. Fig. 5 is an arrangement for cutting the jaws in locomotive side rods; A is the rod to be operated on; B is the pneumatic clamp which holds the rod A in place; C and C-1 are inserted tooth

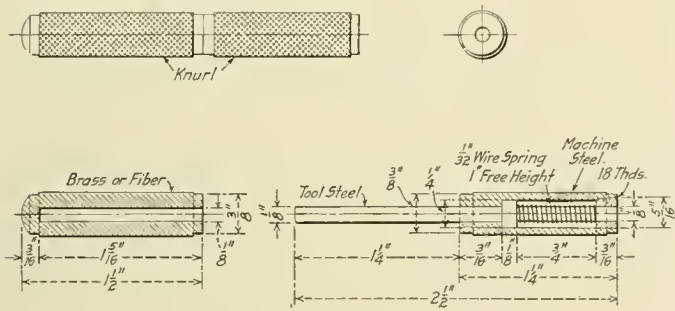

Fig. 7—Depth Gage for Telltale Holes

saws 30 in. in diameter. The saws are spaced the required distance to complete the operation which is done in 15 min., floor to floor.

Thomas F. Eaton, Baltimore & Ohio: We use a special

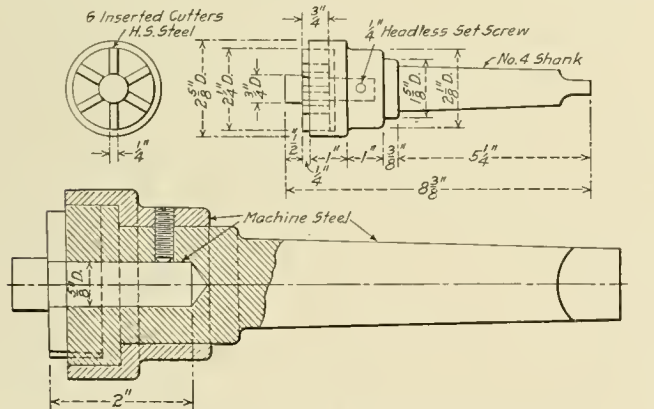

Fig. 8—Rotary Scarfing Tool

reamer for making one large hole in the tube sheet so that tubes may be drawn out easily. This reamer is of the shell type with a No. 4 shank screwed into the back, 3 in. long, tapered

half way back to 3/32 in. smaller at the front end. It is cut spiral with a lead of 60 deg. to one turn. It is 5 11/16 in. in diameter, has 25 teeth which are fluted, with a convex cutter. For superheater heads we used a 45-deg. reamer, with a No. 2 Morse taper shank inserted to suit a small air motor. These

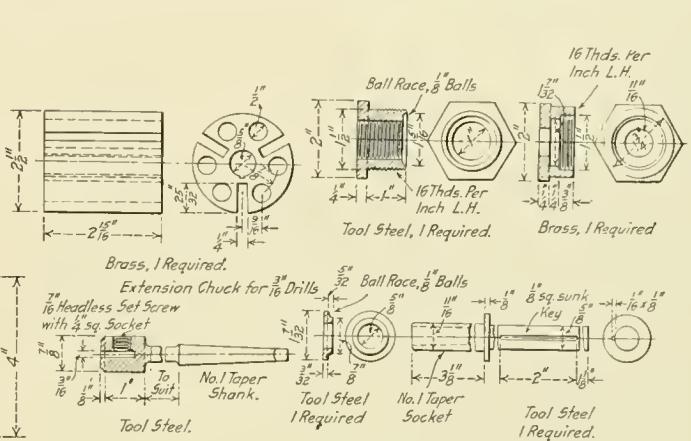
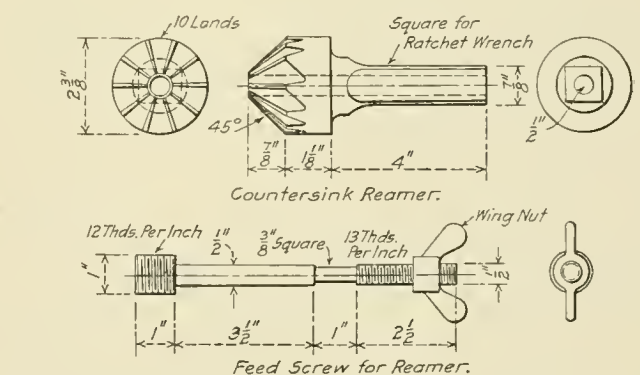
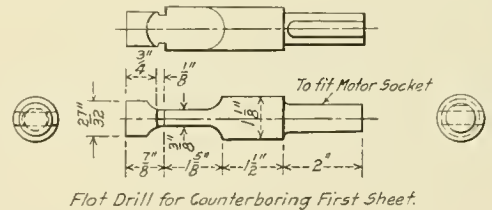

Fig. 9—Tools for Applying Patch Bolts

reamers are made from high speed steel. They have 25 teeth and are ground with 6 deg. clearance. They are milled with a 60-deg. cutter. We have made only our special taps and have given these from .001 to .003 in. clearance according to the pitch. The following is a table of dimensions for special milling cutters:

Diameter.	Number of teeth.	Flute Angle.	Clearance Angle.
6 in.	29	70 deg.	3 1/2
10 in.	37	60 deg.	3 1/2
5 in.	22	65 deg.	5 1/2
6 in.	25	65 deg.	5

H. B. Miller, Big Four: A special tool has been made to drill the holes for arch tubes in both the door sheet and back head



from the outside of the boiler. A machine steel body 14 in. long was made to cover the widest water space. The end is counter-bored 1 in. deep and has 3/8 in. wall. The end is also drilled for a pilot which is fluted so as to be used with staybolt holes. This cutter will bore through both holes in 4 min. The blades are





drill approximately one hole every 40 seconds, fluting all sizes. For rods and crosshead work we use a solid reamer. We use five different reamers for motion work, having seven or nine teeth, according to the size. It is obvious that the greater the number of cutting edges we have, the more line of contact there is to steady the reamer on the walls of the hole. By providing coarse teeth it enables the reamer to be ground faster without drawing the temper, and the cutting edges can be made to cut faster. These reamers are milled with an 8-deg. left hand spiral. I find in providing spiral teeth we maintain a uniform cutting duty which causes the cutting edges to proceed gradually, thus relieving jumping and strain on the machine and giving a smooth finish to the work.

W. E. Goodwin, Chicago & Alton: Fig. 11 shows a reamer for reaming a 1¼-in. Westinghouse air compressor governor body. As these bodies are reamed to ⅛ in. over size it makes it very convenient and economical to have an expansion reamer to do the work. The adjustment is made by loosening nut *A* and tightening up on nut *B*, giving an adjustment of ⅜ in. Fig. 12 shows a flue hole cutter. The cutter part is made of high speed steel screwed into a vanadium steel shank which can be quickly detached. It has also a detachable pilot so that it can be removed when grinding. This makes a very efficient cutter and reduces the upkeep to a minimum. Fig. 13 shows a special tool for cutting oiled grooves in driving boxes on the shoe and wedge bearing. The tool is designed with a triple bearing with two cutters on each gear and so arranged that the grooves will come together with the center ring. The tool has a roller bearing on each side to fit against the driving box jaw and keep it from turning.

#### DISCUSSION

O. D. Kinzey, Illinois Central: All new milling cutters we are making with the wide spacing of the teeth, following the recommendation of the Cincinnati Milling Machine Company. We use coarse teeth and we have doubled our milling machine work. You can take a cut that appears to be ground on the grinding machine, and do it with high speed and a heavy feed. The old styles are obsolete in our shop. Another thing we have done on milling machine work is to increase the diameter of our arbors to 1½ in. The common arbor for tool room milling machine is 1 in., and it is too light. The 1½ in. arbor permits us to double our milling work. All new cutters are made with a 1½ in. hole. We have been handicapped with milling machine work which caused us to look into the matter and we have doubled our work.

We use what is called a helical cutter for milling piston rods. We make these cutters ⅝, ¾, 1 and 1½ in. in diameter. They resemble a twist drill in appearance, only they have three flutes and a very abrupt spiral. We will mill in a piston rod in twenty minutes, driving the cutter by an air motor. We have done away with the old power chip breaker we used to put in. The chip breaker is obsolete for modern practice. If you are not going to use much spiral, use a chip breaker. Another new practice is to make the cutting edge under-cut, so that the milling cutter works similar to a lathe or a machine tool. Get a lip on the milling cutter. With it you turn out chips of remarkable shapes. I think modern milling machine practice is one of the greatest opportunities to produce results before the tool foreman today. I have doubled our work and there is a great deal more to be done before I get up to where I should be.

B. Hendrikson: Don't you think the success of the machine depends on the tempering of the tool? It is pretty hard to get a tool to stand up over a certain speed.

Mr. Kenzie: It depends on the construction of the milling cutter. With the under-cut and the increased spiral tool the heat generated at the point of the tool will dissipate more rapidly, allowing increased speed. For manganese rails they use soft steel cutters that have been put through a case hardening

process, and they are handling that work where the ordinary cutter would not stand up at all. It shows what can be accomplished under scientific manipulation.

G. W. Smith: On our milling machines for rods, especially for channeling rods, we have two cutters. They are what I term a zigzag cutter and they do very effective work. There seems to be no limit to the cutter, but the limit seems to be to the machine. The machines do not seem to be able to stand up for the cuts that are put on them.

Mr. Kenzie: I notice that some are still shaping the collars of rods and doing the milling on a planer. A milling machine will produce a perfect job and will do it in half the time. In regard to Mr. Smith's remarks as to the zigzag cutter, it is a very efficient cutter. We have made several experiments on that new style cutter with the wide spacing of teeth, probably not having more than ten teeth in it, and tests showed that it took less power than the other cutter. When you have a great number of teeth you have to embed more cutting edge in the metal at one time.

A. R. Davis: In the last year I made quite a number of special cutters for milling out the rod jaws for connecting rods. We made a set ranging from 1 15/16 up to 3½ in. in diameter. The blades were high speed steel and inserted in a machine steel shank on the same principle as the Richmond drills are—very coarse flute and the angle of the spiral was 37½ deg. That is as far as I could swing the table around. Those cutters have proven very efficient. We are milling our side rods and middle connection straps. The width of cut will vary from 7½ to 15 in.

#### COLD PUNCHING DIES

C. Henrikson, Chicago & North Western: In boiler sheet punching the first important item is to choose the proper kind of material. The best steel for this purpose is one of low carbon content, about 85 points for both the punch and dies, which should be hardened. The temperature at which the hardening is done should be determined by the carbon content, the higher temperature for the low carbon and the lower temperature with the higher carbon. The approximate temperature should be between 1,700 and 1,800 deg. Fabr. For ordinary boiler punching on holes of ½ in. in diameter and greater, the hole in the die which receives the punch should be 1/16 in. greater than the diameter of the punch. We do not find it necessary to manufacture any of the dies ourselves, as they can be purchased very satisfactorily on the market.

The punches used for sheet iron, tin, copper and brass are commonly called blanking dies. This type of die should preferably be made of a special steel of high carbon content, about 110 points. The method of manufacture varies according to the type of the die. The die is sometimes forged to shape and at other times made directly from stock. The tempering of these dies should be carefully done in order to avoid warping. Where dies are not too large and are symmetrical in shape, oil should be used for the tempering bath. Where oil cannot satisfactorily be used, water is used for the cooling bath. The electric furnace is generally used to heat the dies to the required tempering temperature, which should be between 1,400 and 1,500 deg. No clearance is allowed between the punch and the die in this case. For dies on sheet iron a slip fit should be allowed. Both the die and punch should be hardened. For dies used in punching the tin the fit between the punch and the die should be tight. The plunger is left soft, only the die being tempered. By doing this it is possible to upset the punch by hammering when either the punch or die becomes worn. The following is a list of some of the punching done at the Chicago shops by the use of blanking dies: air pump gaskets, hose strainer blanks and different sizes of guide liners and pipe gaskets. The centers of large gaskets are used wherever possible to punch smaller size gaskets. The method of making dies for leather and rubber is practically the same as that used in making blanking dies. A sort of boss is formed



around the recess of the die and a recess is formed in the punch. Both punch and die are hardened and no clearance is allowed.

DISCUSSION

From the discussion it was pointed out that an ingenious tool room foreman could save a great deal of money by designing dies that would turn out work in an economical manner. Some members recommended a clearance of 1/10 of the diameter of the punch. Work that has been done with the punch press includes emery wheel dressers, beading tool gages, guide bar liners, pipe clamps, and M. C. B. wheel defect gages. Some find it necessary to temper these gages and finish them up in the milling machine, while others harden them directly after they are punched.

CLOSING EXERCISES

The following officers were elected for the ensuing year: Henry Otto, Atchison, Topeka & Santa Fe, president; J. J. Sheehan, Norfolk & Western, first vice-president; C. H. Shaffer, Illinois Central, second vice-president; J. C. Bevelle, El Paso & Southwestern, third vice-president; Owen D. Kinsey, Illinois Central, Chicago, secretary and treasurer. Chicago was chosen as the place of the next meeting, which will be some time next July.

BALL BEARING COLUMN CRANE

BY W. H. WOLFGANG

In shops where floor space must be economized and will not permit of erecting a self-supporting jib crane, a crane of the type shown in the drawings may be secured to a column of the building.

The beam of this crane is made from 1 in. x 6 in. wrought iron or steel. Eyes are forged on the ends of the beam, the brace or strain rod being secured to the curved end and the crane post passing through the other end. The post is made from 1 1/2 in.

The wheels and ball bearings are supported by 1 1/8 in. shafts, the ends of which are reduced to 1 in. in diameter where they fit into the side straps. A 1 in. bolt passing through the side straps

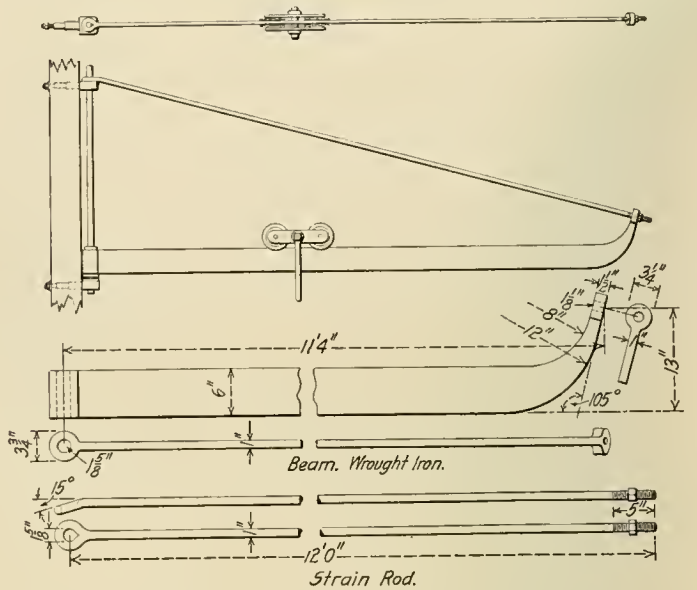

Simple Ball Bearing Crane for Attachment to a Building Column

between the wheels supports the trolley clevis and also secures the side straps against the shoulders on the shafts. This crane has a working capacity of one ton.

RAILROAD ACCIDENT.—On Monday afternoon, as the locomotive and train of cars, from Saratoga to Ballston, came to where the old Saratoga road crosses the railroad, about half a mile east of the latter place, a one horse wagon, with a man and woman

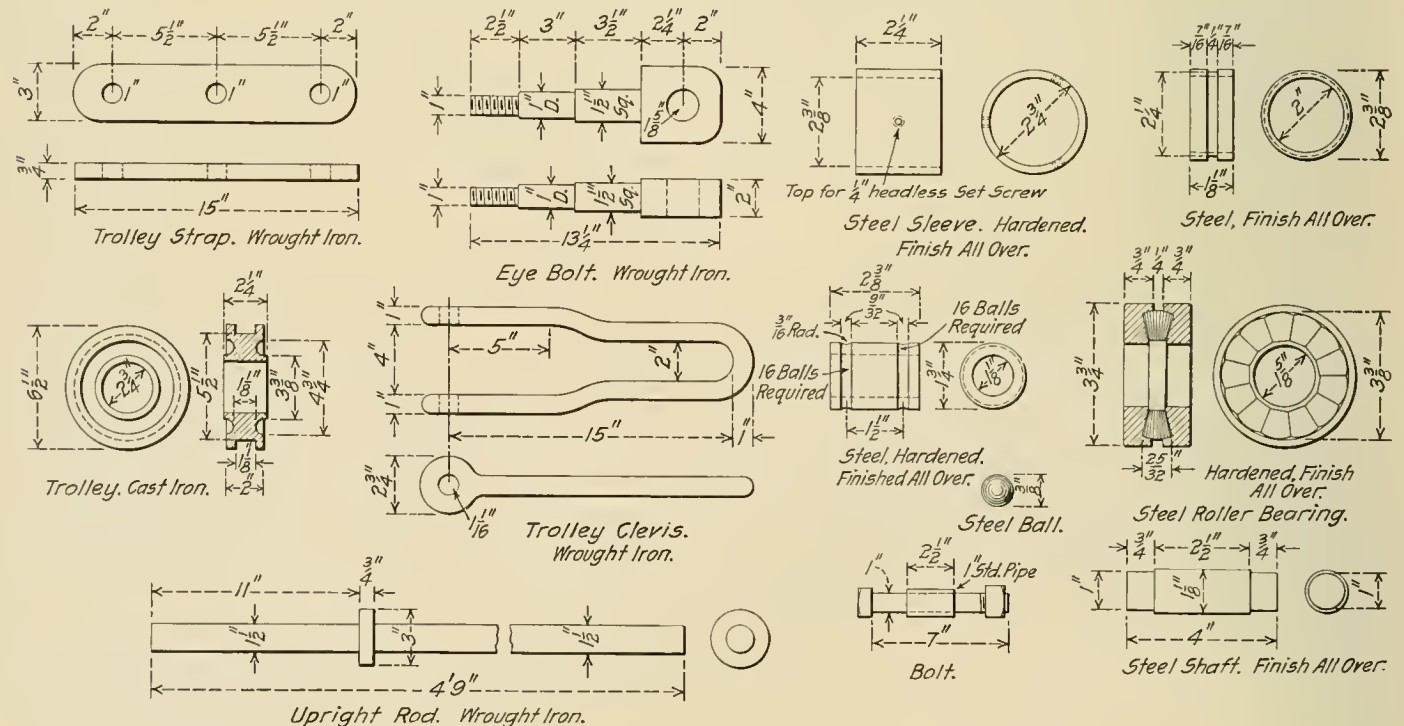

Details of Ball Bearing Crane and Trolley

round iron and revolves in two eyebolts which are secured to the column of the building. The frictional resistance of the beam is greatly reduced by the use of a roller bearing which is shown in detail. Ball bearings are also provided for the trolley wheels.

in it, stopped on the track; the engine came up at the moment, crushed the wagon, killed and mangled the woman in a shocking manner, and killed the horse—the man escaped uninjured.—From the American Railroad Journal, September 5, 1835.

# NEW DEVICES

## GAS PRODUCER INSTALLATION AT THE JUNIATA SHOPS

A gas producer plant has recently been installed at the Juniata shops of the Pennsylvania, which was designed and built by R. D. Wood & Co., Philadelphia, Pa. The plant is made up of two mechanically operated gas producer units, each consisting, primarily, of three parts—the lower or revolving shell, the upper or stationary shell, and the foundation. The drawing shows the general construction. The lower shell contains the fuel bed from which the gas is generated. It rests on rollers which are supported from the foundation, and is revolved by an electric motor through a suitable train of gears. The coal feed and gas outlet are located on the stationary shell, and water-cooled stirrer bars extend into it from the top.

charge. The feed is not automatic, but an automatic feed could readily be installed. The coal handling machinery consists of the track hopper, coal crusher, elevator and overhead bin. The overhead bin has a capacity of 50 tons of coal and is arranged with two chutes, one for each producer unit. The coal is fed by gravity from this bin to the charging hopper located on the producer top plate. A car of coal is dumped over the track hopper from which it is fed by means of a reciprocating feeder into the crushing rolls. From these rolls it is discharged into the elevator boot, the elevator discharging it into the overhead bin.

The ash formed due to the combustion of the fuel is withdrawn from the producer at the bottom through the water pit. Automatic ash removal can be arranged for, if desired. Clinker trouble in the fuel bed is unknown, since the action of the

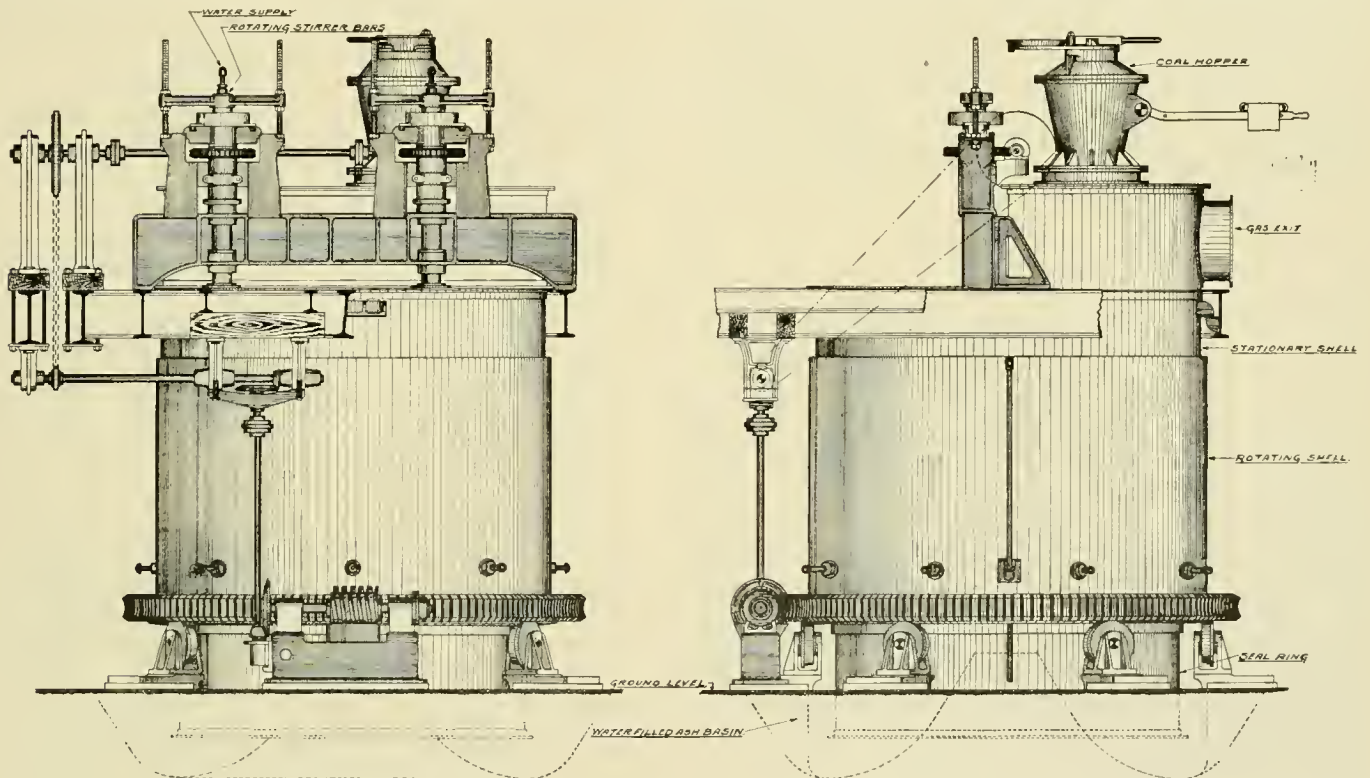

Mechanically Operated Gas Producer at the Pennsylvania Railroad Juniata Shops

Both the stationary and revolving shells are lined with fire brick, the former having a fire brick crown through which the stirrer bars pass. The foundation contains a concrete basin about 6 ft. in depth, upon which rests the ash bed. This basin is filled with water, in which the lower part of the revolving shell is sealed to prevent loss of the air blast. The blast to the producer is carried in cast iron piping through the foundation and is delivered to the center of the producer about two feet below the top of the ash bed, a blast hood of special design being provided at that point.

The stirrer bars are steel forgings, and project down into the fuel bed to a point about 18 in. above the top of the blast hood. They are curved for about 4 ft. from the lower ends, and are rotated by gearing driven from the motor which operates the revolving shell. The effect of the rotating bars in the revolving fuel bed combines to produce complete agitation of fuel bed, and hand poking is entirely unnecessary. Coal is fed through a charging hopper, about 600 lb. being fed at one

stirrer bars is such that little or no clinker can form. By continuous rotation of the fuel bed any clinker that may form is crushed, and is withdrawn through the water seal in sizes not exceeding that of a large walnut.

The diameter of the producer measured inside the fire brick lining is 10 ft. 6 in. Each unit is capable of gasifying or burning 2,300 lb. of coal an hour, continuously 24 hours a day. Two units were installed to furnish gas for use in the smith and boiler shops. The guarantee for the performance of these producers was so far exceeded, however, that it was found that one unit was ample for the requirements of the furnaces. One producer has been in operation for several months and is giving most satisfactory service. The gas furnished is of high and uniform quality, averaging over 150 B. t. u. per cu. ft. of standard gas. It is unnecessary to shut down the producer while ash is being withdrawn, practically no variation in gas quality being noticeable at such times.

The gas used in the furnaces is not cooled or cleaned in any



way, the heat from the producer being utilized, and the producer efficiency being thus increased to approximately 90 per cent.; that is, the gas leaving the producer contains approximately 90 per cent. of the heating value of the coal charged to the producer. Both air and gas are regenerated before entering the furnace hearth.

This installation replaces eleven producers of the old hand-poked type. It was necessary to operate seven of these in order to furnish the same quantity of gas that is now being supplied by one of the mechanically stirred type. The hand-poked type could not be operated continuously, it being necessary to take a unit off the line in order to clean the fire and withdraw ashes.

### PLANER FOR LOCOMOTIVE FRAMES

The accompanying illustration shows a 96 in. by 84 in. locomotive frame planer recently built by the Niles-Bement-Pond Company. It is driven by a 75 horse power reversing motor and is equipped with electric feed and rapid power traverse for the heads.

The general construction of this planer is the same as that of the heavy planers built for the Commonwealth Steel Company by the Niles-Bement-Pond Company, which were described and illustrated in the Railway Age Gazette, Mechanical Edition, of June, 1914, page 323. The same facilities for changing cutting and return speeds, and the same methods of control are provided for both types of machine.

Three heads are provided on the cross rail of the frame planer, and one side head on each upright. The cross rail heads have

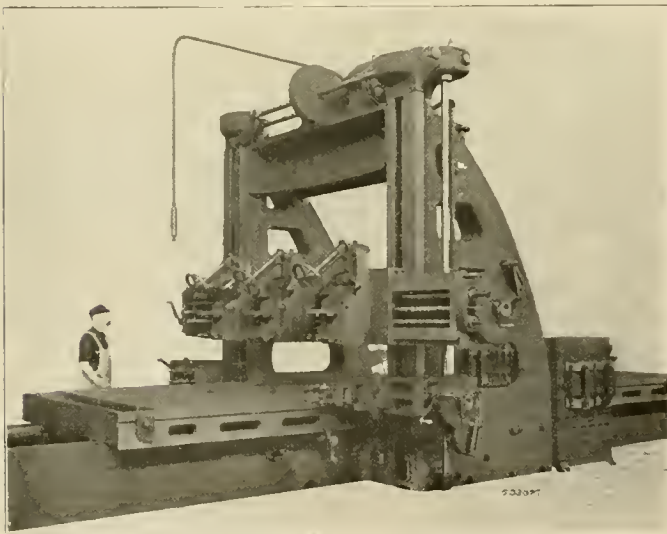

Planer for Locomotive Frames, with Electric Feed and Rapid Power Traverse for the Heads

handwheels operating through bevel gearing for convenient adjustment of the tool slides.

An important feature of this machine is the electric feed and rapid power traverse which is provided for all heads. Both the feed and traverse are operated by a motor mounted on the arch. This motor is also used for elevating and lowering the cross rail. The mechanism for the different operations is interlocked in such a way as to prevent accidental engagement of two functions simultaneously. The amount and direction of the feeds for the cross rail heads can be changed at each end of the rail. The changes of feed for the side heads are made in a similar manner, the feeds for each head being entirely independent of each other and of the cross rail heads. The hand adjustment of the side heads is by a ratchet crank wrench which is mounted on and moves with the head. All heads have graduated swivels and micrometers on the feed screws.

The table is of heavy box section, without openings through the bottom wall. This gives a rigid construction and also prevents chips or cutting fluid from reaching the gears or tracks in the bed.

### ROUNDHOUSE BLOWER VALVE

The globe valve shown in the illustrations has been developed by Jenkins Bros., New York, for use in roundhouse blower lines.

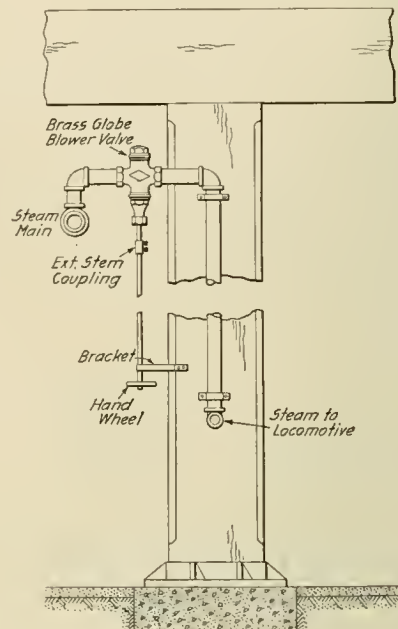

Position of Roundhouse Blower Valve In Pipe Line

The construction is clearly shown in the sectional elevation. By turning the handle to the left the stem forces the disc-

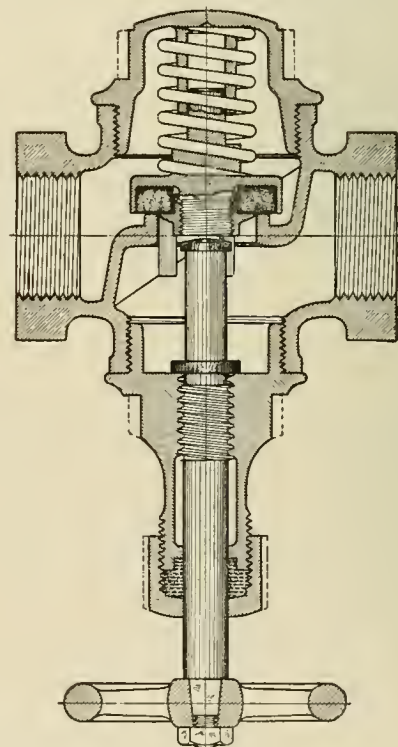

Sectional Elevation of Valve for Roundhouse Blower Line

holder off the seat, thereby opening the valve. On turning the handle to the right the spring forces the disc-holder

against the seat, where it is firmly held by the steam pressure.

In one of the engravings the valve is shown in position in the pipe line, with the stem and hand wheel extended downward to a position convenient for operation. The valve is designed to permit a piping arrangement which will eliminate the trapping of condensation in the connecting pipes, with a valve seating from the top, in the usual manner.

### DRIVING BOX BORING MILL

A 42 in. boring mill with a chucking device designed especially for handling driving boxes has recently been developed by the

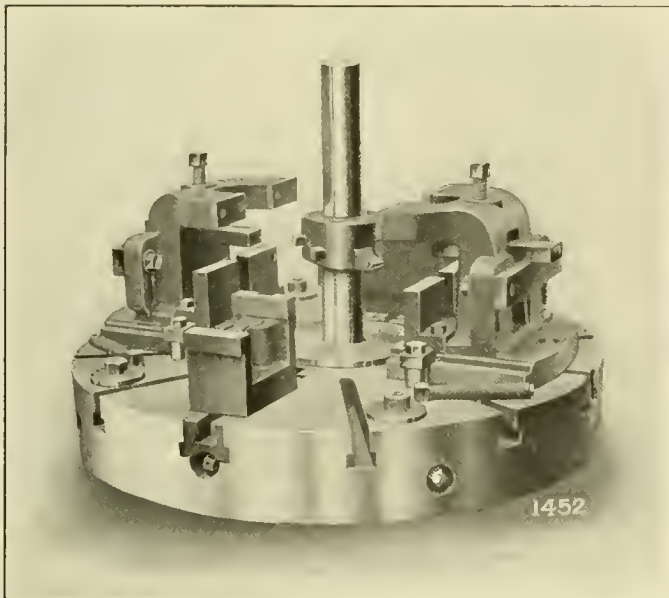

Driving Box Chuck Used on 42 In. Boring Mill

Gisholt Machine Company, Madison, Wis. Considerable attention has been given to convenience in the arrangement of the

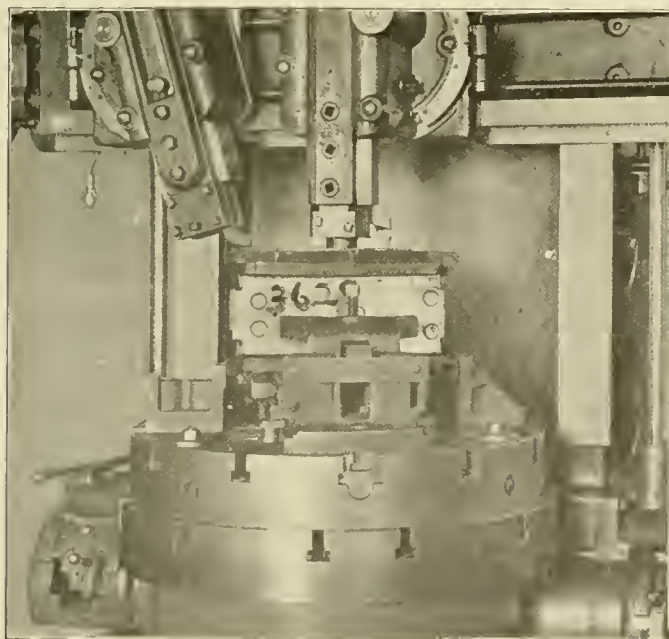
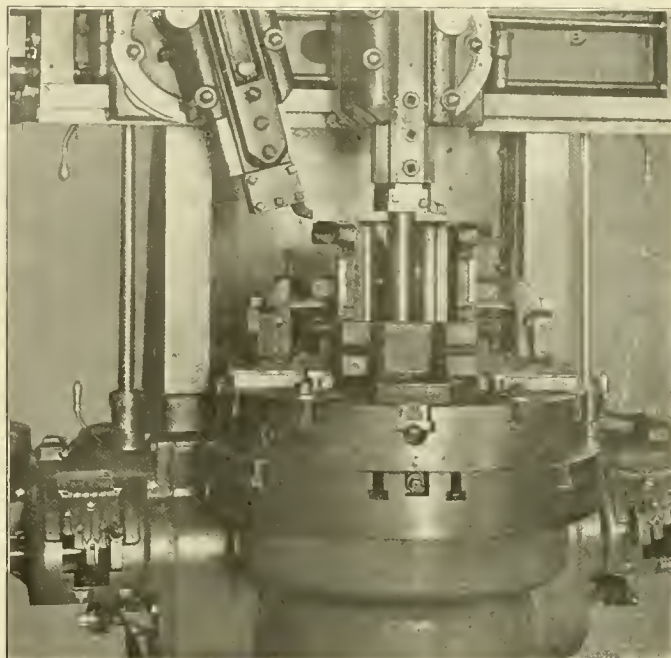

Table Turned to Show Independent Jaws and Long Bearing of Universal Jaws

control and to the protection of the machine by means of feed tripping devices. The table may be controlled by duplicate levers

on either side of the machine. There are two swivel heads, both of which are on the cross rail, one for the boring bar and the other for use in facing boxes for lateral motion. They are both



Driving Box in Position, Showing Universal Jaws and Method of Clamping the Box to the Table

provided with means for rapid traverse by power in any direction, entirely independent of the feed mechanism.

The chucking device, which is shown in one of the illustrations,

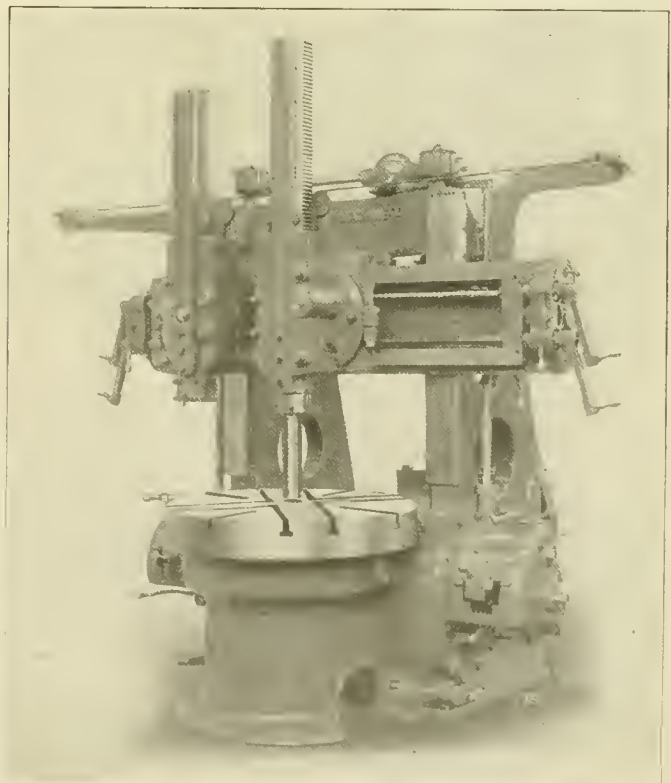

42 In. Driving Box Boring Mill

is a complete unit entirely independent from the table, to which it is clamped by a single screw. The chuck has four jaws, two of which are universally operated and two of which are independent.



In setting up a driving box to be finished the cellar bolt lugs are first set against an adjustable stop block fastened to one of the independent jaws. The location of this block determines the amount of stock to be removed from the crown of the brass. On the opposite independent jaw is a second adjustable block, which is made as low as possible in order to facilitate handling the box. By means of this block the box is secured from movement parallel to its vertical center line. The two side jaws are designed to bear against the shoe and wedge faces of the driving box, and by their universal action insure automatic centering of the box between these faces. These jaws have long bearings against the box in order to insure the accurate location of the vertical center line at right angles to the movement of the jaws. When the box has been properly located it is secured to the table by means of clamps included in the construction of the universal jaws. These clamps are adjustable to suit variations in the thickness of driving box flanges.

After the box has been bored the open ends of the crown brass may be backed off without disturbing the location of the box in the chuck. This is accomplished by setting over the entire chuck the required distance upon the face plate. The movement of the chuck is parallel to that of the independent jaws and normal to that of the universal jaws. In setting up work, if desired the box may be chucked with the universal jaws without attention to the location of the independent jaws, and final adjustment for the amount of stock to be removed made by movement of the chuck on the face plate.

A record of 24 minutes per box, including the time required for setting up and removing from the machine, is claimed to have been made by the use of this chucking device. The box bored was 10½ in. in diameter by 14 in. in length. The stock removed from the crown varying from ¼ in. to 5⁄8 in. The details of the time record were as follows:

Time required for setting up box to be bored.....	3 min.
Time required for taking roughing cut.....	9 min.
Time required for finishing cut.....	7 min.
Time required for setting box over to be backed off.....	1 min.
Time required for backing off crown brass.....	3 min.
Time required for removing box.....	1 min.

Total time for boring box complete..... 24 min.

### TURBINE BOILER TUBE CLEANER

The illustrations show a turbine boiler tube scale remover for fire tube boilers, which has recently been brought out by the Lagonda Manufacturing Company, Springfield, Ohio. The turbine may be either steam or air driven, and soot, loosened by the knocker, is blown out of the tube ahead of the cleaner by the turbine exhaust.

The knocker head is made of three parts, a cylindrical body

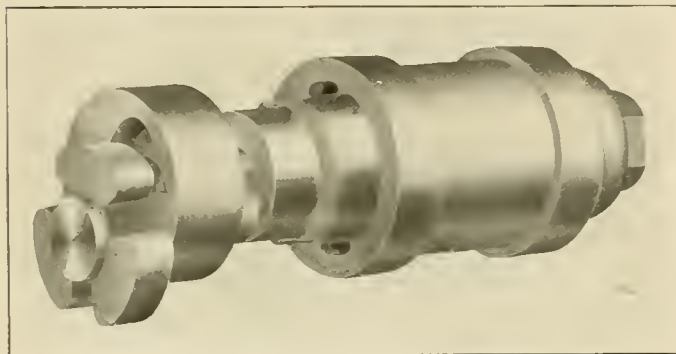

Turbine Fire Tube Cleaner, with Broad Bearing Hammer

somewhat smaller in diameter than the boiler tube, and an eccentrically pivoted lever carrying a clover shaped knocker on a stud at its free end. The lever fits flush in a triangular recess in the forward face of the body, the free end swinging in an arc through the center of the head. The three hammer faces

of the knocker are shaped to fit the inner circumference of the boiler tube, thus giving a large area of contact with the tube, and permitting the use of a heavy hammer without injury to the tubes. The force of the blow thus obtained is claimed to successfully loosen very hard and heavy scale.

The head is driven at a high rotative speed; the eccentrically pivoted lever carrying the knocker is thrown from side to side and the knocker caused to revolve on its axis at each contact with the tube. The resultant gyratory motion to the knocker causes it to hit all points of the interior circumference of the tube. The cleaner is fed into the tube by the flexible rubber hose supplying the air or steam, the revolving motion of the head eliminating the necessity of turning the cleaner by twisting the hose.

The motor is of the rotary type. The air or steam strikes upon radial paddles, which are continually held out by air or steam pressure admitted to a chamber behind them, so that they always form a tight fit with the case. The motor has four paddles, two of which are always under pressure, making it impossible for the motor to stall. A specially designed automatic oiling device is furnished for the motor.

### PILOT OPERATED VALVE FOR HYDRAULIC PRESSES

A direct operating valve which has sufficient capacity for service on hydraulic presses requiring large volumes of water under high pressure, is impracticable because of the difficulty arising in its manipulation. The three-way pilot operated poppet valve shown in the illustrations has been designed for this class of service by the Hydraulic Press Manufacturing Company, Mount Gilead, Ohio.

The main valve, a sectional view of which is shown in the

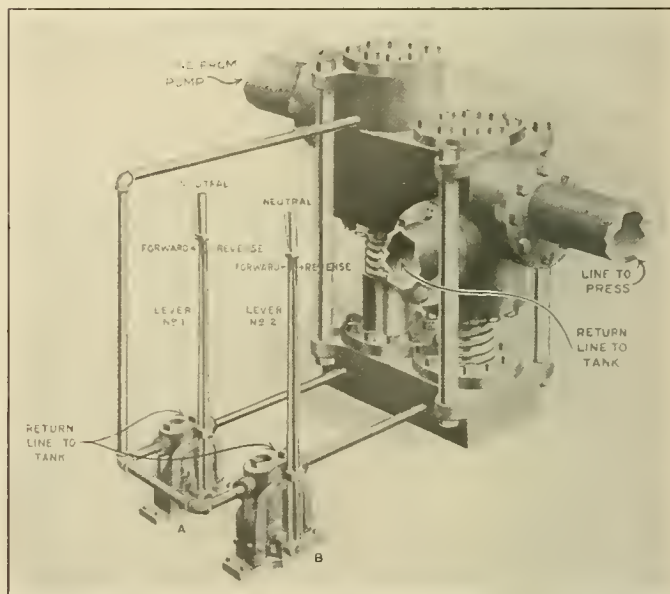

Pilot Operated Poppet Valve for Operating Large Hydraulic Presses

drawing, has three openings and two valves. The valve at the right controls communication between the pump and the press; the other controls communication between the press and the return line to the tank. With both valves open both the pump and the press cylinder are open to the return line, and are therefore both free from pressure. With both valves closed pressure may be retained on both the pump and the press. With the valve to the right open and the other closed, pressure is applied to the press cylinder. With the right-hand valve closed and the other open, pressure is released from the press, but maintained on the pump.

The main valve is operated by means of two small pilot valves shown at *A* and *B*, which control the pressure under the rams shown in the sectional elevation. They need not be located near the main valve, but may be placed at the point most convenient for the operator. Each valve has three openings and three positions. The middle position is neutral, all ports being closed. When the valve is in this position, the pressure is held on the

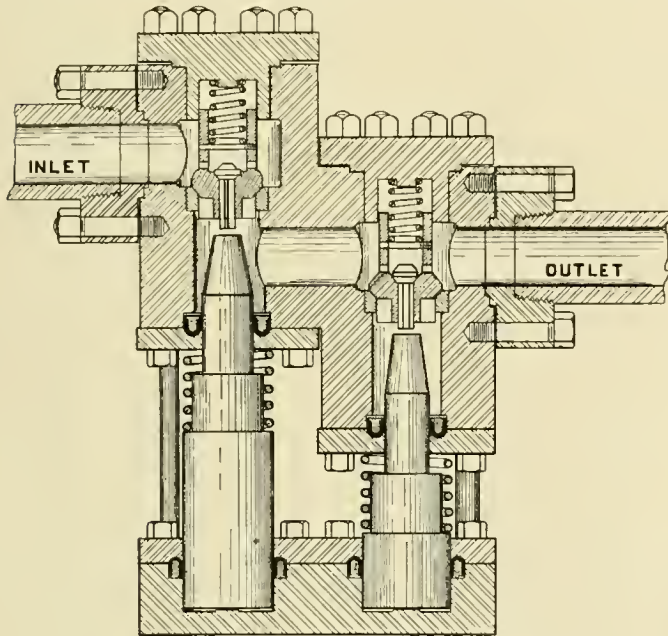

Sectional Elevation, Showing Construction of Main Valve

pressure line and the return line is closed. In the forward position the pressure is applied to the ram, the return line remaining closed. In the reverse position the opening from the pressure line is closed, and the pressure on the ram is released through the return line.

The main valve is designed for pressures of 5,000 lb. per sq. in., or greater. It has a steel body with flanged connections. Special gun metal bronze is used in the construction of the valve seats and checks. The operating cylinders, glands and rams are of cast steel.

### PNEUMATIC RIVET SET RETAINER

Several states are drafting safety appliance laws, among the provisions of which are requirements that riveting hammers embody in their construction means to prevent the accidental ejection of the rivet set from the nozzle of the hammer. A

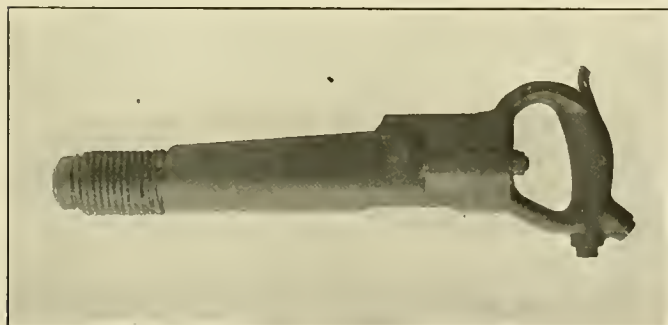

Rivet Set Retainer in Place on Pneumatic Hammer

simple device for this purpose is being applied to the riveting hammers manufactured by the Ingersoll-Rand Company, New York.

As shown in the illustration, the retainer consists of a single

piece of heavy spring steel, closely wound into a spiral form. One end fits over the outside of the hammer nozzle and hooks over a projection integral with the nozzle. The other end is wound to a small diameter. Sets for rivets over 7/8-in. diameter are formed with a coarse thread and are screwed into place in the retainer. Sets for rivets 7/8-in. diameter and smaller are formed with a shoulder and are slipped into the retainer while it is detached from the hammer, the shoulder holding it in place. The device is claimed to effectively prevent the rivet set or piston from being driven out, even when the hammer is running free. The hammer is provided with a groove in the end of the barrel so that a standard retaining clip may be used, if desired.

### PORTABLE ELECTRIC DRILL

A portable electric drill has recently been added to the line of pneumatic tools manufactured by the Independent Pneumatic Tool Company, Chicago.

This drill is equipped with a direct or alternating current motor, being designed to operate on direct current or alternating current of any frequency up to 60 cycles. Both the alternating and direct current motors are of the series winding type and are cooled by drafts of air drawn through the perforated brush cover at the top, past the commutator, between the armature and stator, and exhausted by a fan through a number of holes

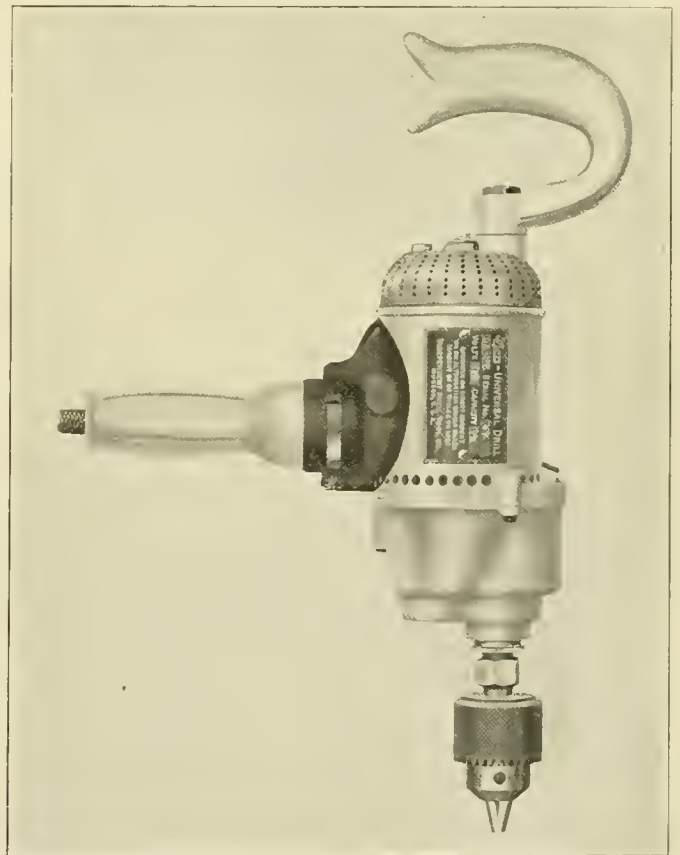

Portable Electric Drill with Speed Change Gears

at the bottom of the stator case. The armature is suspended on Hess Bright bearings, the counter shaft and spindle on Hess Bright and roller bearings. The pinion which meshes with an internal gear on the counter shaft is screwed on to the armature shaft, fitting against a taper shoulder which gives absolute rigidity. When worn it may be readily renewed. The switch is of the self-contained contact disc type, having four contact points and breaking both sides of the line simultaneously. This makes the drill absolutely dead when the switch is turned off.

These drills are enclosed in aluminum cases which make



them exceedingly light in weight. They are made in four sizes having  $\frac{1}{4}$  in.,  $\frac{5}{16}$  in.,  $\frac{3}{8}$  in. and  $\frac{9}{16}$  in. drilling capacities in steel and weighing but 6, 7, 12 and 17 lb., respectively. Each size can be equipped with three different gear ratios giving three different speeds. These speeds are designated by the letters X for high, Y for medium and Z for slow. To obtain these different speeds it is only necessary to exchange two gears for another set. This is done by the removal of the gear case and the nuts which hold the gears on the shafts.

### COAL PASSER FOR TENDERS

At the recent convention of the International Railway Fuel Association a paper was presented on adjuncts for locomotive tenders, in which was briefly described the coal passer of the reciprocating type made by Ryan, Galloway & Company, Chicago.

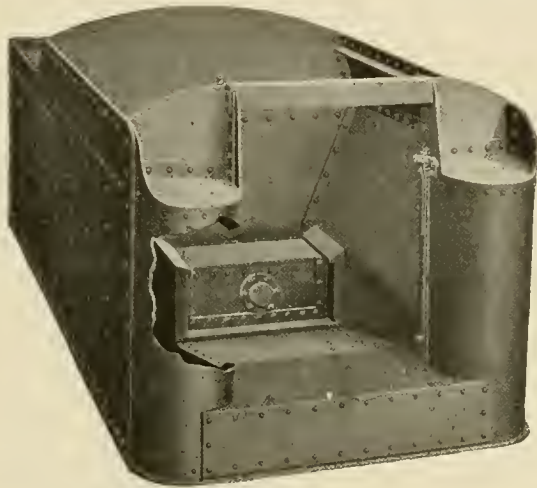

Reciprocating Coal Passer for Locomotive Tenders

Much favorable testimony was offered by members of the association whose roads have been using this type of coal passer, the principal advantages claimed being that it aids the fireman in his work, and permits of his giving better attention to careful

coal in the tender. This feature is also of an additional advantage in that there is less liability of coal accumulating at the back end of coal space and becoming disintegrated and losing its value on account of being exposed to the weather, as well as affecting the coal pit tank sheets. In many cases it would also eliminate the necessity of two firemen on locomotives, as well as having men shovel the coal forward at points along the line.

The illustrations show the coal passer in detail. It consists of a plunger driven by steam, placed in the bottom and back end of the coal pit, occupying its full width. Its sides are about 15 in. high and are provided with flanges (20) which overhang the top of the plunger so as to prevent any coal being drawn back as the plunger recedes. Steel packing strips (A and 18) are also placed at the top and bottom of the plunger respectively for the same reasons. The plunger is supported on the channel iron (14), which rests directly on the floor of the tender. The plunger itself is reinforced by two brackets (11) on each side of the cylinder which contain wheels (12) to provide a roller bearing. The upper rollers operate on the guide rail (10), and the lower rollers on the bottom of the tender. The phantom drawing shows the plunger in its extended position, and it will be noted that the plunger shell extends back over the steam cylinder.

This cylinder is 11 in. in diameter and is operated by steam distributed by the valve shown. The valve is operated by a folding lever placed on the left water leg of the tender convenient to the fireman, who can extend or recede the plunger as desired. The rod (8) and lever (7) are attached to the head of the plunger, as shown, to insure the valve being closed at the end of the stroke, thereby providing a cushion for the piston to work against at the end of each stroke. The steam is admitted through a pipe (23) into the inside admission valve, and the exhaust passes out through a pipe (24), which surrounds the admission pipe so that in cold weather there will be no danger of the exhaust freezing. No. 17 is a vent in the bottom of the steam pipe to permit draining off the condensed steam.

NEW STEAM ENGINE.—It is said the Rev. W. Morris, minister of Deanrow chapel, Wilmslow, in Cheshire, has invented a new steam engine, expense of erecting which will be less than a tenth part of the cost of a steam engine of equal power, and

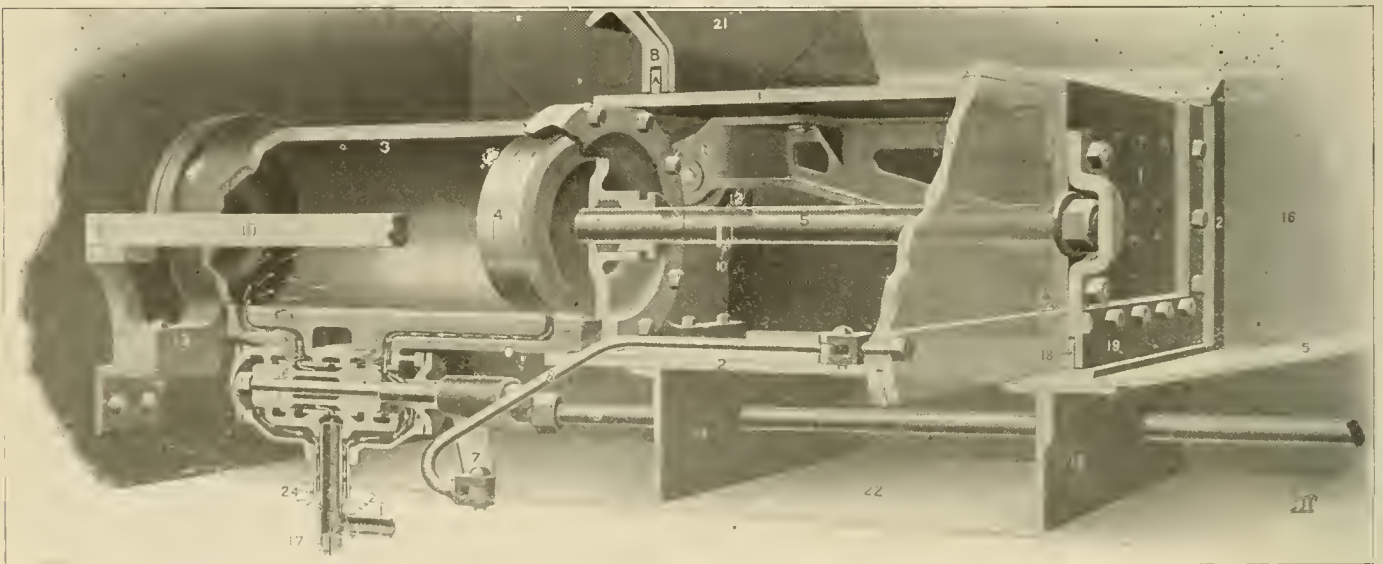

Details of Steam Driven Coal Passer of Reciprocating Type

firing. It was also stated that in numerous cases it was found possible to decrease the number of coaling stops made on different runs, as the fireman could very conveniently use all of the

the expense of working it will be less than one-thousandth part of the expense of working a steam engine of equal power.—*From American Railroad Journal, October 24, 1835.*

# NEWS DEPARTMENT

The new car shops of the Philadelphia & Reading at the coal shipping yard at Pottsville, Pa., have been turned over by the contractors to the railroad company.

The New York, New Haven & Hartford has recently pensioned 13 employees, making 51 altogether retired within three months. George C. Crocker, of Hyannis, Mass., is one of those who have just been pensioned. He is a crossing man who is 82 years old, and has been in the service nearly 60 years.

Two giant cacti, the largest ever moved from the desert, have been taken from Arizona by the Atchison, Topeka & Santa Fe to San Francisco, and have been placed at the entrance to the Hopi Indian village, which forms a part of the \$350,000 reproduction of the Grand canyon of Arizona, being erected on the Panama-Pacific Exposition grounds by the Santa Fe. One of the cacti stands 23 ft. high and weighs 4,500 lb. The removal cost \$1,000 for each cactus.

The Cape Cod Canal, connecting Buzzard's Bay with Cape Cod Bay and shortening by 70 miles the water route between New York and Boston, was opened to commerce July 29, but with only 15 ft. of water, about 10 ft. less depth than will be finally provided. The dedication ceremonies took place at the village of Buzzard's Bay and were witnessed by thousands. Seth Low, president of the Chamber of Commerce of the state of New York, presided. The speakers included August Belmont, president of the canal company; Assistant Secretary of the Navy Roosevelt; Governor Walsh of Massachusetts, and Congressman Thomas C. Thacher, the representative from the Cape district.

Officers of the shop craft unions which struck on the Illinois Central and Harriman lines in 1911 are gathering a large amount of evidence, in connection with the strike, with a view to presenting it to the United States commission on industrial relations. The committee says it is the intention to show that this was not a strike but a "lockout," resulting from the refusal of the roads to recognize their federation. An effort is being made to locate all of the men who struck, and question blanks are being sent out to ascertain how many have lost homes on account of inability to make payments, whether children have been obliged to go to work, whether any of the strikers or members of their families have committed suicide, and other matters of a similar nature.

The New York State Workmen's Compensation Commission reports that the railroads are no longer opposing the application of the workmen's compensation law. They are insuring their risks, some having taken out policies in the state fund while others have given their business to the stock insurance companies. Still others insure their own risks. The distinction between intrastate and interstate employees in applying the law to the railroads is still an unsettled question, and decision in the matter probably will be held in abeyance until the first claims are filed. Four hundred claims for compensation had been filed up to July 8. It was found that only four of these were death claims.

In 1856 the Lehigh Valley had the following rule in effect: "Always leave Mauch Chunk and Easton on time if possible. In case of wet rail or bad track, the morning trains from Easton may leave enough ahead of schedule time to arrive at Bethlehem [eleven miles] before the down passenger train arrives. Run as near schedule time as possible and in no case allow your engineer to run into a station more than

five minutes ahead of time, except at stations where you get your meals, or where you take fuel and water."

## BRITISH RAILROAD ACCIDENTS IN 1913

The number of persons killed in train accidents in Great Britain and Ireland in the calendar year 1913 was 41 and of injured, 871, as follows: Passengers, 33 killed, 723 injured; employees, 8 killed, 145 injured; other persons, none killed, three injured. Of passengers the increase over 1912 in the number killed is 13, and of employees, the increase is 2. The average annual number of passengers killed in train accidents in the years 1902-1911 was 19 and of employees, 9.

Including accidents of all kinds connected with the movement of trains and the conduct of business at the stations, the number of persons killed in 1913 was 1,131 and of injured, 9,054, increases of 120 and of 355 over the totals for 1912. Accidents not connected with the movement of cars or locomotives, are reported in a separate statement; these amount to 63 persons killed and 24,742 injured; so that the total of "railroad casualties" in the most inclusive sense was 1,194 killed and 33,796 injured.

## NEW HIGH RECORD TRAIN LOAD

The Erie's Triplex type locomotive, recently put in service for use as a pusher on Susquehanna Hill was given a hauling capacity test on the Susquehanna division July 23, in which all previous records for train loads, hauled by one locomotive, were broken and a new record established which bids fair to stand unequalled for some time to come.

The test was made from Binghamton, N. Y., to Susquehanna, Pa., a distance of about 23 miles. The train consisted of 250 fifty-ton steel gondolas, each loaded to capacity, and a dynamometer car, and weighed 17,912 tons, exclusive of the locomotive. Its total length was 8,547 ft., or 16 miles. The grade between the two stations is gradually ascending, the worst condition being a combination of .09 per cent grade and 5 deg. curvature.

Pushers were used to assist in getting the train under way. They pushed the slack forward until the Triplex lead locomotive had all the cars moving, after which they were uncoupled and followed the train in case they should be needed again. This operation eliminated the danger of pulling out drawheads in starting, which otherwise would undoubtedly have occurred with a train of such length. Portable telephones were used to communicate from the head end to the rear of the train, and this made it possible for the pushers to do their work in unison with the lead engine in starting the train. A summary of this record breaking haul is given below:

Number of cars in train.....	251
Total weight of train (excluding locomotive).....	17,912 tons
Total length of train.....	1.6 miles
Maximum speed attained.....	14 miles per hr.
Maximum drawbar pull.....	130,000 lb.
Minimum drawbar pull.....	67,000 lb.

A complete illustrated description of this locomotive was published in our issue of May, 1914, page 227. It is probable that exhaustive tests will be made in pushing service on the Susquehanna hill.

## EXTENSIVE UNDERSTUDYING ON THE BALTIMORE & OHIO

To broaden the knowledge of its division officers and give them the benefit of a thorough training with respect to the methods of administering the affairs of the company in the general offices at Baltimore, the Baltimore & Ohio is putting its division officers through a course of employment which will



better equip them for promotion to positions of greater responsibility. Assistant superintendents, trainmasters and, in some instances, their subordinates, are transferred to Baltimore and set at work where they can study the problems of operation from the viewpoint of the general officers. While the staff officials are thus engaged their subordinates discharge the regular duties of the office. The plan, therefore, has the added advantage of equipping the men lower in rank to qualify when vacancies occur.

The men who take the course in the general offices are employed for a period in the transportation department; then in maintenance of way work, in the motive power office, the accounting and statistical departments, and in the tonnage, discipline, employment, station service, rates of pay and other bureaus, so that when they return to their respective divisions it will be with a general knowledge of the relation of their work to the operation of the property as a whole. Several of these men are in the Baltimore offices constantly, and when they go back to their regular duties others are brought in.

### RAILWAY MAIL PAY

In reference to the publication of a report from Washington that the House Committee on Post Offices had taken action designed to increase the allowance made railways for the transportation of the mails, Ralph Peters, chairman of the Committee on Railway Mail Pay, authorized the following statement:

"The bill introduced by Congressman Moon had proposed to reduce the railway mail pay at least \$3,000,000 below what had already been appropriated for this fiscal year. The amendment apparently made to the Moon bill merely provides for the restoration of substantially the \$3,000,000 by which it had been proposed to cut the pay.

"The railroads have contended and they still insist that they are already underpaid at least \$15,000,000 a year. Congress now has at work a bi-partisan commission investigating the question of fact as to whether the railroads are or are not underpaid for this service. It is obviously impossible to properly consider a readjustment until the question of fact has been established.

"The railroad committee believes, therefore, that in justice to the railroads and in justice to the public the report of the joint Congressional commission should be awaited. The railroads are confident that that report will submit a finding on the main question of fact, which will be fair to all concerned.

"When that report is submitted and the question of fact is determined, the railroads' committee will be prepared to cooperate with the government in developing a method of readjusting the underpayments or overpayments in such a manner that the interests of all may be properly protected."

### MEETINGS AND CONVENTIONS

*Chief Interchange Car Inspectors' and Car Foremen's Association.*—The annual meeting of this association, which promises to be of more than ordinary interest, will be held at the Hotel Sinton, Cincinnati, Ohio, August 25-27. The secretary is S. Skidmore, 946 Richmond street, Cincinnati, Ohio.

*American Boiler Manufacturers' Association.*—The American Boiler Manufacturers' Association will hold its twenty-sixth annual convention at the Waldorf-Astoria, in New York, from September 1 to 4. An invitation to attend has been extended to all boiler, tank and stack manufacturers, fabricators of steel plate and representatives of supply companies.

*Master Car and Locomotive Painters' Association.*—The forty-fifth annual convention of the Master Car and Locomotive Painters' Association will be held in Nashville, Tenn., September 8 to 11, inclusive, at the Hotel Hermitage. The subjects to be considered are: Finishing Steel Passenger Equipment;

Rust Inhibitive Paint for Steel Freight Cars; Shop Practice in Finishing New Interior Wood Finish of Passenger Coaches; Locomotive Tender Varnishes; Classification of Interior and Exterior Repairs of Passenger Cars; Apprentice System in the Paint Shop; Results of the Sand Blast as a Paint Remover; Standard Freight Car Lettering, and Blister-proof Paint for Locomotives. A. P. Dane, Reading, Mass., is secretary.

*American Foundrymen's Association and American Institute of Metals.*—The American Foundrymen's Association and the American Institute of Metals will meet in Chicago, September 7 to 11, inclusive, at the La Salle hotel. In connection with this convention there will be a large exhibit at the International Amphitheater, located at the stock yards in Chicago. This should prove of considerable interest to railway men, as a large amount of machine shop equipment will be exhibited. Last year there were 178 exhibitors, 40 of which handled machine shop equipment exclusively. It is, in fact, one of the largest machine tool exhibits held in this country. In addition, there will be a number of oxy-acetylene welding companies represented with working demonstrations as well as electric welding companies, and the Goldschmidt Thermit Company. Railroad men who have the opportunity to visit this exhibit will find it very instructive and much to their advantage.

*International Railroad Master Blacksmiths' Association.*—The twenty-second annual convention will be held at the Hotel Wisconsin, Milwaukee, Wis., August 18, 19 and 20, 1914. The following are the subjects to be considered: "Flue Welding," Wm. T. F. Duggan, chairman; "Making and Repairing Frogs and Crossings," W. F. Stanton, chairman; "Carbon and High Speed Steel," G. F. Hinkins, chairman; "Tools and Formers," Wm. H. G. Sharpley, chairman; "Electric Welding," T. F. Keene, chairman; "Drop Forging," Ed. Dixon, chairman; "Spring Making and Repairing," Hugh Timmons, chairman; "Piece Work and Other Methods," J. E. Dugan, chairman; "Locomotive Frame Making and Repairing," George Hutton, chairman; "Oxy-Acetylene Process for Cutting and Welding Metals," T. E. Williams, chairman; "Case Hardening," P. T. Lavender, chairman; "New Subjects," J. R. Russell, chairman; "Heat Treatment of Metals," John F. Keller, chairman; "Shop Kinks," W. C. Scofield, chairman.

*The following list gives names of secretaries, dates of next or regular meetings, and places of meeting of mechanical associations.*

**AIR BRAKE ASSOCIATION.**—F. M. Nellis, 53 State St., Boston, Mass. Convention, May 5-7, 1915, Hotel Sherman, Chicago.

**AMERICAN RAILWAY MASTER MECHANICS' ASSOC.**—J. W. Taylor, Karpen building, Chicago.

**AMERICAN RAILWAY TOOL FOREMEN'S ASSOCIATION.**—Owen D. Kinsey, Illinois Central, Chicago. Convention, July, 1915, Chicago.

**AMERICAN SOCIETY FOR TESTING MATERIALS.**—Prof. E. Marburg, University of Pennsylvania, Philadelphia, Pa.

**AMERICAN SOCIETY OF MECHANICAL ENGINEERS.**—Calvin W. Rice, 29 W. Thirty-ninth St., New York. Convention, December 1-4, 1914, New York.

**CAR FOREMEN'S ASSOCIATION OF CHICAGO.**—Aaron Kline, 841 North Fiftieth Court, Chicago; 2d Monday in month, except July and August, Lytton building, Chicago.

**CHIEF INTERCHANGE CAR INSPECTORS' AND CAR FOREMEN'S ASSOCIATION.**—S. Skidmore, 946 Richmond street, Cincinnati, Ohio. Convention, August 25-27, 1914, Cincinnati, Ohio.

**INTERNATIONAL RAILWAY FUEL ASSOCIATION.**—C. G. Hall, 922 McCormick building, Chicago. Convention, May 17-20, 1915, Chicago.

**INTERNATIONAL RAILWAY GENERAL FOREMEN'S ASSOCIATION.**—William Hall, 914 W. Broadway, Winona, Minn. Convention, July, 1915.

**INTERNATIONAL RAILROAD MASTER BLACKSMITHS' ASSOCIATION.**—A. L. Woodworth, Lima, Ohio. Convention, August 18-20, 1914, Milwaukee, Wis.

**MASTER BOILER MAKERS' ASSOCIATION.**—Harry D. Vought, 95 Liberty St., New York.

**MASTER CAR BUILDERS' ASSOCIATION.**—J. W. Taylor, Karpen building, Chicago.

**MASTER CAR AND LOCOMOTIVE PAINTERS' ASSOC. OF U. S. AND CANADA.**—A. P. Dane, B. & M., Reading, Mass. Convention, September 8-11, 1914, Nashville, Tenn.

**NIAGARA FRONTIER CAR MEN'S ASSOCIATION.**—E. Frankenberger, 623 Brisbane building, Buffalo, N. Y. Meetings monthly.

**RAILWAY STOREKEEPERS' ASSOCIATION.**—J. P. Murphy, Box C, Collinwood, Ohio.

**TRAVELING ENGINEERS' ASSOCIATION.**—W. O. Thompson, N. Y. C. & H. R., East Buffalo, N. Y. Convention, September 15, 16, 17 and 18, 1914, Hotel Sherman, Chicago, Ill.

## PERSONALS

*It is our desire to make these columns cover as completely as possible all the changes that take place in the mechanical departments of the railways of this country, and we shall greatly appreciate any assistance that our readers may give us in helping to bring this about.*

### GENERAL

J. HAINEN, superintendent of motive power of the Southern Railway at Washington, D. C., has been promoted to general superintendent of motive power and equipment, with headquarters at Washington, succeeding A. Stewart, deceased.

ALONZO G. KINYON has been appointed superintendent of locomotive operation of the Seaboard Air Line. Mr. Kinyon was born at Amboy, Ill., on July 12, 1867. He entered railway service in 1888 as a fireman on the Chicago, Milwaukee & St. Paul, later becoming an engineman. A few months before he left the service in 1901 he entered the railway department of the International Correspondence Schools, and was respectively compound locomotive instructor, air brake instructor, and combustion and fuel economy instructor. He resigned in 1905 to engage in other business, but in 1906 returned to railway work as road foreman of engines on the Southern Railway, where he remained until June 1, 1907. In November, 1910, he was appointed special instructor on fuel economy of the Buffalo, Rochester & Pittsburgh, but left about one year later to become superintendent of combustion and fuel economy instruction with the International Correspondence Schools. On March 1, 1911, Mr. Kinyon entered the railway supply field as chief traveling engineer of the Hanna Locomotive Stoker Company, Cincinnati, Ohio. On April 1, 1912, he left to accept a similar position with the Westinghouse Air Brake Company in connection with the Street stoker, and about one year later he became locomotive fuel engineer of the Clinchfield Fuel Company, Spartanburg, S. C., with which company he remained until his recent appointment, as above noted.

C. T. RIPLEY has been appointed general mechanical inspector of the Atchison, Topeka & Santa Fe, succeeding J. L. Armstrong, promoted.

E. C. SASSER has been appointed superintendent of motive power of the Northern and Eastern districts of the Southern Railway, with headquarters at Washington, D. C. Mr. Sasser was born on November 16, 1875, in Wake county, N. C., and was educated at Holden Academy, Raleigh. He began railway work at the age of 16 in the shops of the Raleigh & Gaston, now a part of the Seaboard Air Line, as machinists' apprentice at Raleigh, and at the completion of his apprenticeship entered the service of the Southern Railway at Alexandria, Va., and was then consecutively machinist, machine shop foreman and general foreman. In 1898 he returned to Raleigh and entered the service of the Lobdell Car Wheel

Manufacturing Company. The following year he went to the Seaboard Air Line at Raleigh, leaving that company in May, 1901, to become superintendent of the Acme Machine Works,

Goldsboro, N. C. He went to the Southern Railway in May, 1902, as erecting shop foreman at Columbia, S. C., and was promoted to general foreman in August of the same year. The following October he left that company to enter the service of the American Locomotive Company at the Richmond branch as equipment inspector. The following year he was promoted to general machine shop foreman, and in March, 1905, left that company to return to the service of the Southern Railway as shop superintendent. He was promoted to master mechanic of the Charleston shops in May, 1908, and in October of the following year was transferred in the same capacity to the Alexandria shops. He was again transferred in May, 1910, as master mechanic of the Spencer, N. C., shops, which position he held at the time of his recent appointment as superintendent of motive power of the same road, as above noted.

### MASTER MECHANICS AND ROAD FOREMEN OF ENGINES

HUGH GALLAGHER, master mechanic of the Atchison, Topeka & Santa Fe at La Junta, Col., has resigned.

D. HICKEY, master mechanic of the Southern Pacific at Sparks, Nev., has been transferred to Ogden, Utah.

### CAR DEPARTMENT

T. D. LAMASTERS has been appointed general car foreman of the Southern Pacific at Ogden, Utah.

E. A. SWEELEY has been appointed master car builder of the Seaboard Air Line at Portsmouth, Va. He will have jurisdiction over the entire car department.

### SHOP AND ENGINE HOUSE

J. L. ARMSTRONG has been appointed general foreman of the Atchison, Topeka & Santa Fe at Corwith, Ill., succeeding W. J. Eddington, deceased.

C. H. BAYNHAM has been appointed locomotive foreman of the Canadian Pacific at Swift Current, Sask., succeeding A. J. Pentland, transferred.

F. W. BENTLEY, JR., has been appointed air brake foreman of the Chicago & North Western at Missouri Valley, Ia.

F. A. BOSWELL has been appointed locomotive foreman of the Canadian Pacific at Moose Jaw, Sask., succeeding C. H. Baynham, transferred.

L. W. HENDRICKS has been appointed roundhouse foreman of the Mahoning Division of the Erie at Brier Hill, Ohio, succeeding C. W. Shane, resigned.

M. MILLER has been appointed locomotive foreman of the Canadian Pacific at Ottawa, Ont., succeeding R. H. McDonald.

R. SPROULE has been appointed day shop foreman of the Canadian Pacific at Winnipeg, Man., succeeding F. Johnson, promoted.

### PURCHASING AND STOREKEEPING

C. D. BALDWIN, purchasing agent of the Bangor & Aroostook at Milo Junction, Me., has moved his office to Derby.

A. A. DAWLEY has been appointed purchasing agent of the Denver & Salt Lake at Denver, Colo.

E. L. FRIES has been appointed general storekeeper of the Union Pacific at Omaha, Neb., succeeding J. H. Stafford, retired under the pension rules of the company.

IRA NEISWINTER has been appointed division storekeeper of the Atchison, Topeka & Santa Fe at Emporia, Kan.

G. W. SAUL, assistant purchasing agent of the Oregon-Washington Railroad & Navigation Company, has been appointed purchasing agent at Portland, Ore., succeeding R. Koehler, retired.

G. E. SCOTT, acting purchasing agent of the Missouri, Kansas & Texas, has been appointed purchasing agent, with headquarters at St. Louis, Mo.



E. C. Sasser



ERNEST BAXTER, whose appointment as purchasing agent of the St. Louis Southwestern at St. Louis, Mo., was announced in the July issue, was born October 11, 1882, at Delmer, Ont. He received a public and high school education, and began railway work in March, 1903, as messenger in the local freight office of the Michigan Central. From May to September he was with the Algoma Central & Hudson Bay as a clerk at Sault Ste. Marie, Ont., and from October, 1903, to March, 1905, he was secretary to the superintendent of the Grand Trunk at London, Ont. Mr. Baxter was then employed successively in the operating departments of the Cincinnati, Hamilton & Dayton at Indianapolis, Ind., and the Missouri Pacific at St. Louis, Mo., until February, 1906, when he became secretary to the general manager of the St. Louis Southwestern at St. Louis. In May, 1909, he was made chief clerk to the president of the latter road, from which position he was promoted to that of purchasing agent on June 22, as above noted.



E. Baxter

HENRY ORVILLE HUKILL, purchasing agent of the Pennsylvania Lines West of Pittsburgh, with headquarters at Pittsburgh, Pa., who retired on June 1, under the pension rules of the company, was born on May 25, 1844, at Steubenville, Ohio, and was educated in the public schools of his native town. At the age of 16 he entered the service of the Steubenville & Indiana, now a part of the Pittsburgh, Cincinnati, Chicago & St. Louis, as a messenger in the superintendent's office. In 1863, he was appointed an assistant operator, and in April of the following year entered the service of the Pittsburgh, Fort Wayne & Chicago and the Cleveland & Pittsburgh, now part of the Pennsylvania Lines West of Pittsburgh, as telegraph operator and clerk in the office of the purchasing agent at Pittsburgh. He was promoted on January 1, 1877, to chief clerk to the purchasing agent, and ten years later was appointed assistant to purchasing agent. He remained in this position until January 1, 1894, when he was appointed purchasing agent of the Pennsylvania Lines West, from which position he now retires after a service of over 54 years on the Pennsylvania Lines. At the time of the retirement of Mr. Hukill, the directors of the Pennsylvania Company adopted the following minute: Mr. Hukill's long service in the purchasing department was noted for the sound judgment and business principles which governed him in all his official relations. The contracts made by him for materials and supplies aggregated enormous sums of money, but



H. O. Hukill

his constant study of market conditions and his knowledge of values enabled him to make these purchases under terms that were advantageous to the company, and at the same time fair to the manufacturers. The integrity of his character and the genial and winning nature of his personality won the esteem and friendship of his associates, and the board of directors takes great pleasure in expressing its appreciation of his able and faithful service and wishes for him many years of happiness and health.

T. D. SINGLETARY has been appointed storekeeper of the Macon, Dublin & Savannah at Macon, Ga., succeeding G. S. Pratt, resigned.

RAY F. TRANSUE has been appointed storekeeper of the Lehigh & New England at Pcn Argyle, Pa., succeeding F. B. Arndt, resigned.

## OBITUARY

DANIEL J. MALONE, superintendent of shops, of the Oregon Short Line, at Pocatello, Idaho, was shot and killed, July 24, by Frank Madden, foreman of the tin shop. The murderer, with the same revolver, at once killed himself. The men were both old employees and had long been friends, but Madden, it is believed, had become mentally unbalanced because of criticisms received on account of unsatisfactory work. Mr. Malone was born at Western Point, Md., in 1860, and he was on the Union Pacific for a number of years before going to the Oregon Short Line in 1880. Madden was 60 years old. Malone had four brothers, two of whom met death in murders very much like this one; Edward in West Virginia in 1896, and Michael, division foreman on the Southern Pacific, in Nevada, in 1906.

SAMUEL F. PRINCE, JR., formerly superintendent of motive power and rolling equipment of the Philadelphia & Reading, died in New York City on July 13, from the effects of a bullet wound. Mr. Prince was born 62 years ago and previous to January, 1892, was mechanical engineer of the Philadelphia & Reading, and then to the following March was assistant consulting engineer of the Long Island. He was appointed superintendent of motive power in March, 1892, and from February, 1893, to August, 1899, was superintendent of motive power and equipment of the same road. On August 1, 1899, he was appointed superintendent of motive power and rolling equipment of the Philadelphia & Reading, and left that company in June, 1904, to enter the service of the Niles-Bement-Pond Company, at New York. He retired some years ago from active service on account of ill health.

## NEW SHOPS

ATLANTIC COAST LINE.—A contract is reported let to D. J. Rose, Rocky Mount, N. C., for improvements at Florence, S. C., to include a roundhouse, a turntable, planing mill and machine shop.

CHICAGO & NORTH WESTERN.—This company is contemplating building a 180-car capacity repair yard at Clinton, Iowa. There will be a total of four buildings, one brick veneer mill building, 60 by 150 ft., one brick veneer shop building, 50 by 100 ft., one frame store building, 22 by 150 ft., and one frame lumber shed 22 by 100 ft. The estimated cost is about \$80,000.

ILLINOIS CENTRAL.—This company is planning to lay out a small yard and to construct shops at Dyersburg, Tenn., the total costing about \$150,000.

NORTHERN PACIFIC.—A roundhouse and locomotive plant, consisting of a 33-stall roundhouse, a machine shop with 7 repair pits, a tank and paint shop with 5 repair pits, a turntable, coal docks and a three-story brick storehouse will be erected near the Union depot at St. Paul. Estimated cost, \$500,000.

## SUPPLY TRADE NOTES

The Railway & Traction Supply Company has moved its office from room 1307 to larger quarters in room 504, Rector building, Chicago.

W. G. Willcoxson has been appointed representative in the railway department of the Garratt-Callahan Company, with office at 27 South Clinton street, Chicago, Ill.

The American Flexible Bolt Company, Pittsburgh, Pa., has opened offices at 50 Church street, New York, with R. W. Benson in charge as general sales manager.

H. W. Green, for the past ten years district sales agent for the American Steel Foundries in Pittsburgh, has been elected vice-president of the Lawrence Steel Casting Company, Pittsburgh, Pa.

Charles R. Crane will retire shortly as president of the Crane Company, Chicago, to be succeeded by R. T. Crane, Jr., now first vice-president, and R. T. Crane, 3rd, will be advanced from second vice-president to first vice-president.

John W. Dix has been appointed assistant general sales manager and structural engineer of the Carnegie Steel Company, Pittsburgh, Pa., succeeding John C. Neale, who has resigned to become president and general manager of the Central Steel Company, Massillon, Ohio.

Stephen C. Mason, secretary of the McConway & Torley Company, Pittsburgh, Pa., has accepted appointment as an executive member of the Railway Business Association. William McConway, president of the same company, recently retired as an executive member of the association.

Harry C. Holloway, who was for several years representative of the Rail Joint Company, New York, resigned on July 1 and opened an office in the Railway Exchange, Chicago. He will handle railway supply accounts, representing among other companies the Keystone Grinder & Manufacturing Company, of Pittsburgh.

The American Car Roof Company, Chicago, manufacturer of the Christy steel freight car roof, has changed its method of business and now gives the right to build the Christy roof on cars to the car builders themselves on a royalty basis. This arrangement makes it possible to equip a car with this particular roof, in the same shop that the car itself is being built.

Mudge & Co., Chicago, are now manufacturing and selling their own passenger car ventilator which is known by the trade name "Mudge-Peerless." This company is now representing in western territory the Chambers Valve Company of New York. The Chambers throttle valve now being exclusively manufactured by the latter company was recently acquired from the Watson-Stillman Company.

The Railroad Valuation Company has recently been organized, with offices at 25 Broad street, New York, with a staff of engineers, analysts and accountants of wide experience in valuation work for the purpose of preparing maps and other data for railroads who have to submit such data in the federal valuation and may not otherwise have the advantage of a special staff for this work.

Ralph W. Perry, chemist and engineer of tests for the Michigan Central during the construction of the Detroit river tunnel and the improved terminal facilities at Detroit, has severed his connection with the company and has leased its laboratory at Fifth street and River Front, Detroit, renaming it the Perry Testing Laboratory, with the idea of conducting a general chemical, inspecting and testing business.

Joseph T. Ryerson & Son, Chicago, have taken over the plant, merchandise, equipment and good will of the W. G. Hagar Iron

Company, St. Louis, Mo. It is the intention of the company to supplement the plant of the latter with complete modern warehouses and equipment for the handling and cutting of shapes, reinforcing bars and similar heavy material. Ryerson & Son will thus be able to render immediate service in their lines of finished steel to customers in the territory tributary to St. Louis.

On June 19, the United States patent office issued to William R. McKeen, president of the McKeen Motor Car Company, Omaha, Neb., patent No. 352,725, covering all-steel box cars, including underframe, superstructure, the steel box, the steel bracing and the diagonal bracing. This patent has been in litigation since 1906 in two interference cases which have been passed on by the examiners in chief, the commissioner of patents and the court of appeals of the District of Columbia, sustaining practically every claim made by Mr. McKeen. The Union Pacific steel box cars built in 1906 and 1907 were built under this patent.

C. W. Cross has been appointed Chicago representative of the Equipment Improvement Company, New York. Mr. Cross began his railroad experience with the Pennsylvania Lines West and left that system when assistant master mechanic at Fort Wayne to become master mechanic of the Lake Shore & Michigan Southern, with headquarters at Elkhart, Ind. He was made superintendent of apprentices of the New York Central Lines in 1906 when that system revised and centralized its apprenticeship department to meet modern conditions. Mr. Cross' work in the development of this department is widely known and requires no comment.

Judge Hazel in the U. S. District Court at Buffalo has upheld the directors and majority stockholders of the United States Light & Heating Company, Niagara Falls, N. Y., in the receivership of that corporation by ordering the answer of Henry A. Ackerman stricken out and vacating the appointment of receivers in the action which was brought by the Picher Lead Company. Simultaneously, he appointed James O. Moore, of Buffalo, and James A. Roberts, of New York, receivers in a new action brought by the Central Trust Company of New York, which holds \$200,000 of the company's notes. The Central Trust Company is not antagonistic to the existing control of the United States Light & Heating Company. The plaintiffs in the other receivership proceeding, Henry A. Ackerman and G. M. Walker, who were appointed receivers at the outset of the Picher Lead Company's action, were removed a few days ago.

THE SMOKE NUISANCE IN 1835.—For a method of building chimneys that will not smoke, contract the space immediately over the fire so you may be sure of the air being well heated there; this will ensure a current upwards. All chimneys should be carefully built, and every joint well filled with mortar, so as to prevent communication in case of fire. (Dr. T. Cooper.)—*From American Railroad Journal, August 22, 1835.*

USE OF SILVER IN MOVING PICTURE FILMS.—The largest single use for silver, outside of the manufacture of silver-plated ware, is in the manufacture of photographic plates, films, and paper. The manufacture of films for moving picture use has now become an enormous business, and it is probable that in the future this will bring the largest consumption of silver. The silver is used in photography for making the light-sensitive emulsion and is principally the bromide of silver.—*The Engineer.*

TROY AND BALLSTON RAILROAD.—We learn, by the Ballston Gazette, the railroad from the city of Troy to that village is so far completed, that the new engine with a train of passenger cars will arrive there on Thursday or Friday from Waterford. Thus it is that one railroad after another is brought into use; and it will not be many years before the mode of traveling on all the great thoroughfares will be by railroad and steamboat.—*From the American Railroad Journal, August 15, 1835.*



## CATALOGS

**JACKS.**—Catalog No. 102 of the Duff Manufacturing Company, Pittsburgh, Pa., contains 143 pages, and is devoted to the various types of jacks manufactured by this company. It is profusely illustrated.

**FORGING MACHINE.**—National Forging Machine Talk No. 4 has been issued by the National Machinery Company, Tiffin, Ohio. This is illustrated and deals with the effect of big die opening on the economy of forging machines.

**COAL PICKS.**—Circular No. 67 from the National Malleable Castings Company, Cleveland, Ohio, describes the malleable iron coal picks for locomotive tenders manufactured by this company. Two different types are dealt with in the leaflet.

**STEEL TAPED CABLE.**—The Simplex Wire & Cable Company, 201 Devonshire street, Boston, has issued a catalog dealing with the Simplex steel taped cable. It is claimed that this cable can be used underground where a conduit system is too expensive.

**HOSE COUPLING.**—A four page circular from the Gold Car Heating & Lighting Company, Whitehall building, New York, describes their No. 804-S steam hose coupler. The special features of this coupler are a gravity safety trap and an oscillating gasket.

**SIDE HEAD BORING MILL.**—The Pratt & Whitney Company, Hartford, Conn., has issued a catalog dealing with the side head boring mills manufactured by this company. A large number of very clear illustrations are included as well as descriptive matter.

**HYDRAULIC PRESSES.**—Catalog No. 40 from the Hydraulic Press Manufacturing Company, Mount Gilead, Ohio, contains 128 pages, and includes descriptive matter and illustrations of the various lines of hydraulic presses and accumulators manufactured by this company.

**LOCOMOTIVE VALVE GEAR.**—A 39 page booklet recently issued by the Pilliod Company is devoted to illustrations of locomotives to which the Baker valve gear has been applied. It also contains information relative to the number of engines which have been equipped.

**HAMMERS.**—A 64 page catalog has been issued by the David Maydole Hammer Company, Norwich, N. Y. This catalog contains illustrations of hammers for a great variety of uses with specifications and complete indexes in English, French, German and Spanish.

**FLEXIBLE STAYBOLTS.**—The Flannery Bolt Company, Pittsburgh, Pa., has issued the 1914 catalog of the Tate flexible staybolt and tools for its installation. This book is very completely illustrated and will be found of great value wherever these bolts are used.

**HEAT TREATING FURNACES.**—Tate, Jones & Company, Inc., Pittsburgh, Pa., has issued a 32-page catalog illustrating and describing their line of heat treating furnaces. These furnaces are for annealing, hardening and tempering steel and for all heat treating operations.

**CRANES.**—Catalog No. 110 superseding No. 82 has just been received from the Whiting Foundry Equipment Company, Harvey, Ill. It contains 48 pages illustrating and briefly describing the various types of cranes manufactured by this company, and will be sent free upon request.

**DETACHABLE LINK BELT.**—Advance section A of general catalog No. 110 from the Link-Belt Company, Chicago, is devoted to the Ewart detachable sprocket wheels. It contains 112 pages and gives a large number of illustrations and much information pertaining to this apparatus.

**ELECTRIC FIXTURES.**—The Safety Car Heating & Lighting Company, 2 Rector street, New York, has recently issued a 95-page catalog of electric lighting fixtures for car lighting. This catalog

is very nicely gotten up and includes illustrations of a wide variety of fixtures for all sizes of work.

**SERPENTINE SHEAR.**—The Lennox serpentine shear is dealt with in bulletin No. 1371, issued by Joseph T. Ryerson & Son, Chicago. This machine is intended for straight and irregular cutting of sheets and plates, and can be furnished in different sizes varying in capacity from No. 16 gage to  $\frac{1}{4}$  in.

**OXY-ACETYLENE WELDING AND CUTTING.**—The Macleod Company, 213 East Pearl street, Cincinnati, Ohio, has issued a 40-page catalog dealing with the Buckeye Oxy-acetylene welding and cutting outfits. The catalog contains illustrations and data pertaining to the different sizes and types of this equipment.

**INSERTED TOOTH MILLING CUTTERS.**—Bulletin No. 6 of the Tindel-Morris Company, Eddystone, Pa., is devoted to the Tindel inserted tooth milling cutter. These milling cutters are intended for any class of milling work and simplicity of design, durability and ease of maintenance are among the points claimed for them.

**BRAKE RODS.**—An eight page booklet issued by the Schaefer Equipment Company, Oliver building, Pittsburgh, Pa., describes the solid forged truck lever connections manufactured by this company. These rods are formed without welds, from heavy steel plates, the ends being drop forged to form reinforced holes and jaws.

**BALL BEARINGS.**—The S. K. F. Ball Bearing Company, 50 Church street, New York, has issued bulletin No. 16-3M dealing with the application of their product to electric motors. It contains 37 pages, and includes a large number of illustrations showing the application of S. K. F. ball bearings to various types of motors.

**DRILLS.**—The July number of Drill Chips, issued by the Cleveland Twist Drill Company, Cleveland, Ohio, is devoted to an interesting account of the processes followed in the manufacture of drills from the time stock is received at the works until the drills are ready for shipment. It contains 16 pages and is well illustrated.

**FRICTION SAW.**—Bulletin No. 9,071, issued by Joseph T. Ryerson & Son, Chicago, describe the Ryerson high-speed friction saw. This machine is for use in railroad car, frog and switch shops, and can be furnished for any type of current or voltage, and equipped with either hand wheel hydraulic, pneumatic or independent motor feed.

**CAR VENTILATION.**—Catalog No. 101 of the Railway Utility Company, 226 South La Salle street, Chicago, is devoted to the various types of car ventilators manufactured by this company. In addition to descriptions of the ventilators it contains a number of illustrations showing their application to both steam and electric railway passenger equipment.

**CAR HEATING SUPPLY VALVE.**—Circulars have been issued by the Gold Car Heating & Lighting Company, Whitehall building, New York, describing the packless quick opening supply valves with both single and double outlets which have recently been developed by this company for use in car heating systems. Sectional views of the valves clearly show the construction.

**ELECTRIC INDUSTRIAL LOCOMOTIVES.**—Descriptive leaflet No. 3,723 from the Westinghouse Electric & Manufacturing Company, East Pittsburgh, Pa., deals with the Baldwin-Westinghouse electric locomotives for industrial work. These locomotives are for use in industrial plants and on plantations as well as for hauling coal cars in power houses and other special work.

**STORAGE BATTERIES FOR LOCOMOTIVES.**—Bulletin No. 146, dated May, 1914, from the Electric Storage Battery Company, Philadelphia, Pa., is devoted to the Ironclad-Exide battery for storage battery locomotives. The bulletin contains 18 pages and includes a number of illustrations of locomotives fitted with this type of battery as well as descriptive matter, tables and diagrams.

# Railway Age Gazette

MECHANICAL EDITION  
INCLUDING THE  
AMERICAN ENGINEER

PUBLISHED ON THE FIRST THURSDAY OF EVERY MONTH BY THE  
SIMMONS-BOARDMAN PUBLISHING COMPANY,  
WOOLWORTH BUILDING, NEW YORK, N. Y.

CHICAGO: Transportation Bldg. CLEVELAND: Citizen's Bldg.  
LONDON: Queen Anne's Chambers, Westminster.

EDWARD A. SIMMONS, *President* L. B. SHERMAN, *Vice-President*  
HENRY LEE, *Secretary*

The address of the company is the address of the officers.

Roy V. WRIGHT, *Editor*

R. E. THAYER, *Associate Editor* C. B. PECK, *Associate Editor*  
A. C. LOUDON, *Associate Editor* GEORGE L. FOWLER, *Associate Editor*

Subscriptions, including the eight daily editions of the *Railway Age Gazette* published in June in connection with the annual conventions of the Master Car Builders' and American Railway Master Mechanics' Associations, payable in advance and postage free:

United States, Canada and Mexico.....	\$2.00 a year
Foreign Countries (excepting daily editions)....	3.00 a year
Single Copy .....	20 cents

Entered at the Post Office at New York, N. Y., as mail matter of the second class.

WE GUARANTEE, that of this issue 4,650 copies were printed; that of these 4,650 copies 3,645 were mailed to regular paid subscribers, 150 were provided for counter and news companies' sales, 236 were mailed to advertisers, exchanges and correspondents, and 619 were provided for samples and office use; that the total copies printed this year to date were 32,950, an average of 4,328 copies a month.

VOLUME 88

SEPTEMBER, 1914

NUMBER 9

## CONTENTS

### EDITORIALS:

Master Blacksmiths' Convention.....	449
Inspection at Engine Houses.....	449
The Draft Gear Problem.....	449
Car Department Competition.....	450
Designing Locomotives to Suit Conditions.....	450
Vibratory Requirement for Staybolt Iron.....	450
Mechanical Department Records.....	450
A Word of Thanks.....	451
Limitations of the Designer.....	451
New Books.....	451

### COMMUNICATIONS:

Melted Boiler Tubes.....	452
Reclaiming Scrap Material.....	452
Spring Versus Friction Draft Gears.....	453
Bracing of Boiler Heads.....	454

### GENERAL:

Largest Non-Articulated Locomotive.....	456
Abating Smoke and Increasing Efficiency with Hand Firing.....	458
Predetermination of Locomotive Performance.....	458
A Few Facts About Locomotive Valve Gear.....	461
Powdered Fuel.....	462

### CAR DEPARTMENT:

Uniform Inspection for Special Loading.....	463
Armored Car for Mexico.....	464
Importance of the Draft Gear Problem.....	465
Some Notes on Chilled Cast Iron Wheels.....	470
Interchange Inspectors and Car Foremen's Convention.....	473

### SHOP PRACTICE:

Turning Crank Pins in a Quartering Machine.....	475
Dies for Forging Running Board Saddles.....	475
Pipe Bending Machine.....	476
Organization of Engine House Forces.....	477
Master Blacksmiths' Convention.....	481
Goggles in Railroad Shops.....	488
Removing Stand Pipes.....	488

### NEW DEVICES:

Horizontal Boring, Drilling and Milling Machine.....	489
Band Saw for Cutting Metal.....	490
Portable Steam or Air Hoist.....	490
Pipe Bending Machine.....	491
Monorail System with Fixed Tongue Track Switches.....	491
A Process of Casehardening with Gas.....	492
Service Records of Chrome-Vanadium Rolled Steel Tender Wheels.....	493
Hydraulic Bushing Press.....	494
Electric Lathe Center Grinder.....	494

### NEWS DEPARTMENT:

Notes.....	495
Meetings and Conventions.....	496
Personals.....	497
New Shops.....	499
Supply Trade Notes.....	499
Catalogs.....	500

### Master Blacksmiths' Convention

The convention of the International Railroad Master Blacksmiths' Association, held in Milwaukee last month, was attended by a large proportion of the membership of the association. Those who registered attended all sessions, both morning and afternoon, in goodly numbers. The program included reports on fourteen subjects, which, in the time allotted, could not help but seriously limit the discussion. The association is apparently trying to fully cover its field at every convention. The wisdom of this, especially when no advance papers are published, may be questioned. It would seem better to restrict the subjects to those that are calling for the greatest attention at this time. By doing this the members would come to the convention better prepared for the discussion of the different reports. Some of the less important subjects could be taken up every other year, or every three years. The suggestion of Mr. Carruthers that the number of members of the committees be decreased in order that the committee members may have greater responsibility is a good one, and it is believed, will produce better results.

### Inspection at Engine Houses

Most of the articles received in the recent competition on engine house work laid stress on the value of a thorough inspection of locomotives when they arrive at engine houses. There was a time when locomotives were considerably smaller than they are today and working conditions were different, when every engineman took a direct interest in the locomotive which he was operating and could be depended on not only to make a thorough inspection and report all the work necessary, but to personally attend to small defects. Undoubtedly the pooling of engines has had a great deal to do with the falling off in this interest on the part of enginemen and while it is decidedly rare to come across a man who cannot find enough work to report to fill considerable space in the work book, it by no means follows that the locomotive has been thoroughly inspected. It is doubtful whether it is advisable to relieve the enginemen entirely of the responsibility of inspection; considerable success has been reported in some cases where the practice is employed of making the shop inspector go over the entire locomotive and furnish an independent report. The practice varies to quite an extent, but there can be no doubt that a thorough inspection at the engine house by an inspector who is a trained mechanic will help greatly in the finding of small defects and remedying them before they become large ones and run up the cost of repairs.

### The Draft Gear Problem

In this number appears the last of the series of contributions which were accepted for publication as a result of the draft gear competition. They all favor the friction draft gear, as did two out of twelve of the papers which were recommended by the judges for publication. In still another part of the paper will be found an interesting and forceful communication favoring the spring gear as compared with the friction draft gear. It presents an entirely new viewpoint and rounds out the discussion as far as it has thus far progressed. We hope for, and in fact we shall be greatly disappointed if we do not receive many other communications on this most important problem now that the articles presented in the competition have been placed on record. What points have you noticed that have not been covered? What data have you that will help to clear up the problem? We want it—our readers need it! One thing is apparent. The Master Car Builders' Association has a big opportunity before it if it will promptly and effectively investigate and report on this problem. Railroad clubs and other similar organizations should actively come to the front in agitating and discussing it. The American Rail-



way Association will be remiss in its duty if it does not order an investigation and report on abuses to equipment by the operating department, and at the same time insist on an immediate and thorough investigation of the draft gear problem by mechanical department officers. Theory and guess work should be relegated to the background and hard, cold, practical facts should settle the problem once and for all. If they are not available, and apparently they are not to any very great extent, then those in authority should set the machinery in motion to develop them, for surely the problem is not insurmountable if properly handled.

#### Car

#### Department

#### Competition

The series of articles on defective box cars and damaged freight which appeared in the Railway Age Gazette about two years ago attracted considerable attention and since that time there has been quite an advance made in the design, construction and maintenance of box cars along the lines of providing greater protection for the lading. There remains a great deal to be done, however, and with a view to developing a better understanding of the defects of box cars and the remedies which should be applied, we announced in the August issue, page 395, a competition to close October 15, 1914, on defective box cars and how the defects may be eliminated. Leaving the draft gear out of consideration, what, in your opinion, is the greatest defect in box cars and how can it best be remedied? A prize of \$50 will be awarded for the best paper outlining what the writer considers the most important defect and providing suggestions as to how it may be overcome. The judges will base their decision on the practical value of the suggestions offered. Articles which are not awarded a prize, but which are accepted for publication will be paid for at our regular space rates.

#### Designing

#### Locomotives

#### to Suit Conditions

In discussing the distribution of power on page 278 of the June, 1914, issue, we stated that it should not be expected that all locomotives will work equally well under all conditions. A great deal can be accomplished toward economy by carefully studying the conditions obtaining on different parts of a railway and distributing the locomotives to the various divisions according to their suitability to the different conditions. Some roads have found it necessary to go to considerable trouble and expense in studying the assignment of power to the best advantage, a great deal of which could have been avoided by a careful study of conditions before ordering new locomotives and the working out of designs to cope with these conditions. It is by no means uncommon practice for a railroad to order a number of locomotives of one class and after they arrive to distribute them to different parts of the road with very little regard to their suitability to the work in that section, the only consideration being that there is a shortage of power there. It is because of such practices as this that locomotives with large driving wheels are, in quite a number of cases, being used on districts with heavy grades where locomotives with smaller wheels would do the work much more satisfactorily; on the other hand, it is poor practice to design locomotives to suit the heaviest operating conditions on a large road, such as heavy grade, short curvature and heavy trains and then employ exactly the same locomotives on districts running through a level country where there are few curves. Another poor practice is the ordering of a number of locomotives all equipped with one type of grate and then operating them on different parts of the road where the fuel conditions are dissimilar.

When such practices as these obtain, a railway is not getting the maximum possible number of ton-miles per ton of coal from its locomotives. Economy in fuel consumption is

one of the greatest single problems that confronts the railways today. A few roads seem to be giving this problem the attention it deserves, but there remains much to be done. The matter of locomotive design has a direct and very considerable bearing on fuel economy and if, in ordering new locomotives, designs are selected to suit the conditions which are to be met and the engines then kept as nearly as possible on the service for which they were originally intended instead of being distributed indiscriminately over the entire system, a long step will have been made in the right direction in the campaign for fuel economy. Such an action may, it is true, require a greater number of designs to be employed, but there is no reason why the matter of interchangeability of such parts as it is desirable to standardize should be materially affected.

#### Vibratory Requirement for Staybolt Iron

It is well known that the physical characteristics of iron and steel, as determined by static tests, do not necessarily indicate that the metal may not fail after a relatively short period of service, under stresses well within the elastic limit. Several types of vibratory testing machines have been developed during the past few years in an effort to provide a test, the results of which will bear a direct relation to the ability of the metal to maintain its strength and ductility in service. A vibratory test would seem to be the logical means of determining this ability to resist fatigue, and it should be especially useful when applied to staybolt iron. So far, however, such tests have not been satisfactory. Specimens of iron taken from the same bar and tested in the same machine have shown results varying so widely that the reliability of comparisons between different irons based upon the results of similar tests is very much in doubt. This is probably due to lack of rigidity in the machines and to lack of sufficiently close uniformity in the test specimens. Developments, however, may be confidently expected which will overcome these difficulties.

The machines now in use vary widely in construction and methods of operation and the results are not comparable. This condition stands in the way of the general use of a vibratory requirement in specifications for staybolt iron, as was brought out at the recent meeting of the American Society for Testing Materials in the report of the committee on standard specifications for wrought iron. This committee, after a series of tests, found it impossible to formulate a standard method of testing which could be adhered to on any two types of machine; and a vibratory requirement will not be included in the standard specifications for staybolt iron until a machine of sufficient merit presents itself to warrant its choice as a basis on which to formulate a standard vibratory requirement. The inclusion of such a requirement in specifications for staybolt iron, in the present state of the art, does not seem justified either as a means of comparison between irons or as a basis upon which to accept or reject material.

#### Mechanical Department Records

It is a strange attitude that is assumed by some mechanical department officers toward any suggested increase in clerical work, such as the introduction of a new form for record-keeping purposes. They seem to cling tenaciously to the idea that there are too many records kept already and that any addition to them is worse than useless. It is true that there are many records kept of a nature that makes their value extremely doubtful; but it is very often the case that while those kept are of little use and the time employed in their preparation could be used to better advantage in some other way, there is time being lost elsewhere because of a lack of data which could be obtained readily if the proper records were available. Chief clerks should be in a good position to tell what records are necessary and what ones are not, and a very good test to place on each one

is the question, "Is it supplying necessary information; if so, is it supplying it in the best and most concise form?" Any record which will not stand this test should be discontinued. On the other hand, experience and necessity should dictate the starting of new records; a chief clerk who finds himself continually having to furnish information along lines not covered in existing records should be able to judge for himself whether or not it is desirable to keep a permanent record of such information, and if it is desirable, a new form should be started. The mechanical departments of many railways suffer more from a lack of information, due to insufficient records, than they do from too much record keeping. There are mechanical department officers who do not make improvements in their shops or in their organization, simply because they have nothing to show them where such changes are needed, a condition that would not exist if the proper records were kept. In this connection it is strange that the graphical method is not employed to a greater extent than it is; this means of keeping records is so extremely simple and gives desired information so much more plainly and quickly than do tabular forms that its use could be greatly extended to advantage.

**A Word  
of  
Thanks**

The popular conception of an editor seems to be that of a hard and tireless worker who sits in his sanctum with shirt sleeves rolled to the elbow and by many means of communication which center in his den feels the pulse of the field which he serves and prescribes the treatment which he considers will best meet the needs of the patient. This is all well enough as far as it goes, but the editor in the technical field today finds it necessary to go far beyond this. He must be on more or less intimate terms with the men on the firing line who are doing things and must spend a large part of his time outside of his office studying conditions first hand. His efforts are successful only insofar as he can enlist and hold the hearty co-operation of the men who are doing things. He is expected to do and say the right thing at the right time and to act as a pioneer or beacon light in pointing the way to better things. He does not expect applause or appreciation for this. He does not want it, except as it may indicate that he is "hitting the nail square on the head."

What he does want and what he greatly appreciates is frank and square-from-the-shoulder criticisms of things which are published in his journal, or additional data or facts to back up his conclusions. His whole heart and soul is set on bettering things in his particular field and indications of interest and helpfulness spur him on to greater efforts. If there is one thing that really makes him feel bad it is an expression such as the following when he visits a district from which he has been absent for some time: "You were away behind when you published that stuff about the Ureaka Railroad last year. We can beat it all hollow." How much better it would have been had the editor been advised concerning it when the question was a live issue. Two or three minutes and a two-cent stamp would have done this. Better still, a clear-cut, concise letter for publication would have done a considerable favor to both the readers and the editor.

It is with this in mind that we wish to extend hearty appreciation to those of our readers who have contributed so freely and so well to the communications in this number. They are splendid. Please do not picture the editor as a dignified, cold-blooded machine, who is too big or too far away to be your confidant, or who does not need your help. He is just as human as you are and in the effort to keep in close touch with progress and to rightly judge the trend of events he needs the help of every reader; after all we are really one big association with one common interest and each one of us owes it to all the others to do our little part in

making the mechanical department more effective and more efficient. Will you help the editor?

**Limitations  
of the  
Designer**

The engineman, after his first trip on the new locomotive, climbed down out of the cab with a satisfied smile on his face. "That is sure one fine engine," he said. Why? It was supposed to be a duplicate of the previous order and was built at the same works. Examination proved, however, that it differed in many minor respects in the arrangement of the apparatus in the cab and that the engineman had good cause for his commendation. The arrangement of the apparatus on the back head and of the various levers and valves which the engineman had to use were remarkable for the neatness of arrangement and convenience in handling. As the engineman put it: "Everything is exactly where it ought to be and it is just like falling off a log to handle her. We never had anything like it on this road." How did this improvement come about? Who was responsible? On the earlier order of locomotives the leading locomotive draftsman laid out the arrangement of this apparatus. He had never run a locomotive. He had seldom been on one, but he was a bright young fellow who had had a splendid shop experience after a good college training.

Who, then, was responsible for the cab arrangement on the new locomotives? The general road foreman of engines had visited the builders when the first cab was being fitted up and seating himself on the engineman's seat box had pointed out exactly where the levers and valves, gages, etc., should be placed. He knew nothing about design, but had spent his life running locomotives. As a result, old locomotives are now being changed as fast as conditions will permit and practice, not theory, will hereafter govern the arrangement of cabs on that particular road. It was because the mechanical engineer realized the limitations of his staff that the general road foreman had made the trip to the works. It was because this same mechanical engineer utilized the practical knowledge of operating department and car repair department officers that his office is credited with designing a particularly good box car from the standpoint of protection to the lading. One of the good signs of the times is the way such co-operation is being extended on most of our railroads. Truly it is a healthy sign when the designer awakens to a sense of his limitations.

**NEW BOOKS**

*Traffic Glossary.* By R. E. Riley, instructor in Interstate Commerce, La Salle Extension University, Chicago. 136 pages, 6 in. by 9 in. Bound in paper. Published by La Salle Extension University, Chicago, Ill. Price \$1.

This book was prepared primarily for use in connection with the La Salle University courses, but it should be found of great use to any student of traffic matters in obtaining information as to the terms in general use. The book is divided into four sections, one giving definitions of traffic territory, the second containing definitions of traffic terms and abbreviations, the third treating of the application of classifications and the last containing test questions.

*Air Brake Catechism.* By Robert H. Blackall. 406 pages, 4½ in. by 6½ in., 149 illustrations. Bound in cloth. Published by the Norman W. Henley Publishing Company, 132 Nassau street, New York. Price \$2.

To a great many railroad men this book will need no introduction. The fact that this is the twenty-sixth edition indicates the position which it holds in the railway field. It is a complete treatise on the Westinghouse air brake, including the latest development in the E-T equipment and the P-C passenger brake equipment. The air train signal system is also considered as well as train inspection and train handling. The question and answer form has been followed. Several of the illustrations are full page colored plates.



## COMMUNICATIONS

### MELTED BOILER TUBES

TOPEKA, Kan., August 12, 1914.

TO THE EDITOR:

In your issue for August, page 397, appears an article on "Melted Boiler Tubes," signed by XYZ, with a note stating that the correspondence explains itself, and that you would be glad to have any of your readers give the details of a similar experience.

Some years ago the writer had a similar experience, which was more damaging than the one in question. This was a Prairie type engine which had been fired up without water. The fire was in the boiler not to exceed forty minutes, when this was discovered. The fire was knocked and there was apparently no damage to the box. In the course of an hour or so it was discovered that some of the flues were red hot. The fire was built at 4 p. m., and at 1 a. m. the stack had the appearance of a cupola casting off molten metal. The boiler had some 360 flues, all of which were melted back to from 6 to 10 in. from the firebox end. The boiler got so hot that the checks were melted off the outside, the front flue sheet was wasted in thickness  $\frac{1}{8}$  in., and molten metal ran out around the steam pipes and exhaust stand and in the water space of the throat sheet in the firebox; the result was that we had to renew the outside casing of the throat sheet as well as three bottom courses in the boiler. The firebox was not damaged. This firebox did not have any arch tubes or arch brick, so the trouble could not be attributed to heat from the brick arch. I will not try to explain the phenomena, as at the time this occurred there were all kinds of theories advanced, and probably the discussion of the subject in your columns will bring out the real cause.

L. H. Y.

CHICAGO, Ill., August 13, 1914.

TO THE EDITOR:

Referring to the damaging of locomotive boiler tubes and the tube sheet in the front end because of internal combustion, as noticed in the August issue, page 397, I wish to direct attention to a case which occurred on the Chicago & North Western in October, 1909.

We had a small four-wheel switch engine working at Racine, Wis. When in need of a washout, it was taken to Milwaukee, about 23 miles away, on Saturday night. In this particular case it had worked some twelve hours at Racine, before it started for Milwaukee. Owing to a delay caused by a derailed freight car, the engine crew of the switch engine found that the legal working hours would expire before reaching Milwaukee and the dispatcher instructed them to leave the engine at Cudahy, about six miles from the terminal and it would then be taken in by a freight train.

The engine crew knocked out the fire and extinguished it as much as they could with water. They left the engine at 9 p. m. with 40 lb. of steam in the boiler and a full glass of water. The engine was towed to Milwaukee some time during the night and was in the yard at the roundhouse at 6:30 a. m. when the foreman looked it over and ordered it moved into the roundhouse, instructing the boiler force to have it washed out and leaving instructions as to what repairs should be made. Shortly after the engine was placed in the roundhouse, the boilermaker foreman advised the general foreman that something was wrong with it. He stated that in making the connections for washing, they found that one of the hand hole plates had been removed some time between the time the engine was left at Cudahy and its arrival at Milwaukee and that when water was allowed to drip into the boiler from the overhead connection, a considerable volume of steam rushed out of the hand hole.

They first looked in the firebox and found no fire whatever but could see a reflection at the front end of the flues. They opened

the front door and the flues seemed to be red hot and getting hotter all the while. They closed the front door and took off the boiler check. The check was found to be very hot, but they could not see any fire in the boiler interior. They again opened the front door and the flues immediately began to become white hot and it seemed that a slight blue flame was escaping from around the flues where they were inserted in sheet, indicating that there was gas burning on the inside of the boiler. The front door was again closed and a steam hose was connected from the blower line to the check valve opening in the boiler, permitting the steam to enter the boiler shell. There were some slight explosions, but when the front door was again opened it was observed that the flues were cooling off. The flue sheet, after being cooled, appeared to have been in a fire. It was red, as were the flues extending back from the front end for about 2 ft. The flues were all loose in the sheet; otherwise no damage was done, and after calking the seams at the front end of the boiler, the flue sheet seams, and re-rolling the flues, the engine was again made serviceable.

We did not give this occurrence very much publicity, as it seemed to be rather uncanny. The flues were clean inside and out. The front end had no cinders in it that might catch fire; the firebox was not equipped with a brick arch and I cannot give any reason for this heating but do believe now that admitting steam to the inside of the boiler saved it from the same experience as the one you illustrated in your August number.

E. H. WADE,

Supervisor of Motive Power and Machinery,  
Chicago & North Western.

### RECLAIMING SCRAP MATERIAL

AMARILLO, Tex., August 15, 1914.

TO THE EDITOR:

Since the Atchison, Topeka & Santa Fe has placed material supervisors at the different shops we have been able to reduce the material charges about one-half by inspecting all old and second-hand parts and picking out those that may be repaired and used in place of new material. The scrap bins are carefully watched to see that no material is scrapped that can be used. Such parts as globe valves, nuts, bolts, brasses of all kinds, and all kinds of tools are repaired and used. When an over-supply is on hand the surplus is turned in to the store house, and the department thus remitting receives credit for it. Oftentimes piston rods that are removed from large engines may be used on smaller engines; in this case they are sent to the store house and the proper credit is given on the new rods. Bolts of all kinds are reclaimed by straightening and recutting the threads, or in some cases, by cutting them off to a shorter length and rethreading them, they then being used as new bolts. The nuts are reclaimed by rethreading when it is possible to do so.

Many good globe valves are sometimes thrown away when all that is necessary to put them in good condition would be a new packing nut, disc, or perhaps the straightening of the stem. By applying these parts we save the price of the entire valve, which ranges anywhere from 80 cents to \$5. Another large item is the matter of rod bushings; when they become a little loose and worn we close them by applying shims and tightening them in the rods, instead of throwing them into the scrap bin. Wrist pins, when they become loose in the crosshead, are removed and turned down for smaller engines; they also make good knuckle joint pins. Wash out plugs which are too small for the original holes, are chased down to a smaller size and given to the boiler washers, who use them instead of new ones. Wheels which are removed on account of rough journals, worn flanges, or shelled parts, are delivered to the store house, credit for them being given, less the amount of labor charges for putting them in good condition. If the tire is too thin and will not stand another turning we get credit for the axle and wheel center.

We have a preparation for polishing the bullseye lubricator glasses when they become black. By keeping them in good con-

dition in this way we have not found it necessary to draw a bullseye lubricator glass from the store house for more than eight months. Flue ends over 6 in. long that are removed from new flues when being applied are sent to the store house and credit for them is received.

Classification lamps, markers, oil cans and shovels, are repaired by our supply man, who puts in new handles, solders up the leaks, or applies new glasses, as may be required. Every Monday morning each mechanic is given a half pound of waste, which is to last him for the week. At first the men thought they could not get along with this amount, but we found that the men who complained the most were not using their waste properly, and soon convinced them that they would be allowed no more. Since that time it has been found that the half pound will last them very satisfactorily. We feel that these material supervisors have saved the company considerable money, and their expense is fully warranted by the work they do.

C. G. COATES.

### SPRING VERSUS FRICTION DRAFT GEARS

HARVEY, Ill., August 13, 1914.

TO THE EDITOR:

In reading your editorial and other writers' views on the draft gear problem as published in the July and August issues, it appears to me that the friction draft gears have been over-estimated. We have in this country two classes of cars, passenger and freight, and to illustrate this more forcibly I have compared them with the home dog and the tramp dog. The home dog (the passenger car) is fairly well taken care of according to the ability of its master. The tramp dog represents the freight car and he is kicked from one place to another and nobody cares whether he has any nourishment or shelter—even at a bumping post—the main thing being to get him off one's hands without giving him anything. The draft gear represents the energy in keeping him moving and, when he has lost this energy, he is a dead dog; same with the freight car.

Much has been written and more has been said on the draft gear question than on any other part of the car, and less has been accomplished, because no conclusions have been reached whereby any body of men could agree on the essential points, which are, the capacity for absorbing and destroying shocks; initial resistance to permit an easy starting of the train; flexibility between maximum and minimum, because of its effect on the drawbar pull and buff to prevent break-in-tuos.

As a rule draft gears are purchased on the recommendation of the mechanical engineer, who has gone over the various laboratory tests. Alas, the gear that showed such beautiful geometrical curves while under the care of the mechanical engineer in the laboratory is smashed to smithereens by a switchman when put to actual service conditions. When a draft gear is applied to a car, every known laboratory condition is changed, there being no feature surrounding the service test corresponding to that by which the results shown on the graphic charts were produced. Even when cars are on a tangent or straight track, the impact or blows resulting from two cars coming together are seldom, if ever, under the same conditions that would obtain with a single gear in a testing machine.

It is well known that there is a vast difference between a mechanical engineer and a railway switchman; the former takes one single gear into the laboratory and takes the time necessary to very carefully and gently compress it. On the other hand, the switchman is less careful. He throws a cut of loaded cars down against other cars standing still with the usual high sign (put them into clear), which means at speeds of from five to ten miles an hour, and sometimes more, and it is all done in less than a second. Such shocks could never be absorbed or destroyed by any draft gear, whether friction, spring or any other sort.

Thus we are forced to admit that we are unable to entirely absorb or destroy the shocks with any kind of a draft gear.

The underframe must do it or the car is out of commission. The only thing that can be done is to furnish sufficient resistance for ordinary running conditions; this should be, under present conditions, not less than 100,000 lb. The average tractive effort of road engines does not exceed 60,000 lb. The average tonnage trains do not exceed 3,000 tons per train.

I, therefore, favor higher capacity spring gears. Spring gears properly applied will retain their capacity, while friction gears will wear out. I have seen many of them with absolutely no resistance whatever; still, the trainmen will pull them and the inspectors will pass them as long as they hold together. They move from one end of the pocket to the other, just like a solid block, producing more lost motion in a train than the link and pin arrangement ever did, because of the greater drawbar travel of the friction gears.

The friction draft gear people say the slack should be taken up as fast as it wears out. That is true, but is it? Not that I have noticed. I made an inspection of 150 cars equipped with friction draft gears a short time ago that were standing in the yard bunched together, and I found that an average of one out of every five cars had the horn of the coupler solid against the head blocks. This proved to me conclusively that either the friction parts were worn out, or that there was not sufficient recoil in them to move them back to normal position. That the friction draft gears show up better in the train and laboratory tests when new is entirely due to the difference in capacity, but they fall far short of the mark after a year or two of actual service. Obviously where there is friction there is wear, and the higher the resistance the faster the wear. I find this to be the case even with the coupler carry irons, which only carry the weight of the couplers. What must it be with a draft gear that has a resistance 500 times greater than the weight of the coupler?

In the laboratory tests given by Mr. Newell, a 9,000 lb. weight falling 5½ in. closing the most powerful draft spring solid, shows discrimination between the spring and friction gears, as no one would use a single spring gear at this date when four or more double coil springs may be used in each end of the car. Put four of the same springs in a group and the result will show four times greater and the springs will retain their resistance for the life of the car, while the friction gears will not.

The greatest argument against the spring gears is a supposed recoil, but recoil we must have, or we have no draft gear. If the recoil is as great as some people say it is, some of our trains would be aeroplanes, as no one hesitates to place sufficient springs in the trucks of cars to properly carry the load. I have seen people place a 30,000 lb. spring in a testing machine and drop a 9,000 lb. weight on it at various heights and watch it rebound. But, if these people would only drop a 50,000 lb. weight on the same spring, the result would be entirely different. It would fall dead.

The best results that were ever obtained in railroad train service, as I remember it, was when the springs in the end of the cars exceeded the carrying capacity of the cars. The trouble today is that the capacity of the cars exceeds the capacity of the draft gear, be it either of the spring or friction type. To satisfy yourself of this fact, go out in any yard when tonnage trains are pulling out and you will find 90 per cent of the draft gears stretched out absolutely dead by a locomotive with a tractive effort of less than 60,000 lb.

It is generally conceded that as soon as the friction faces become polished the gear loses half of its original resistance, but it is not admitted that it falls below the tractive efforts of an ordinary road engine.

It is not a question today of having sufficient drawbar travel to start freight trains, but it is a question of having an engineer that can start a train without breaking it in two, due to excessive drawbar travel. The principle is wrong, the resistance should be increased and the drawbar travel should be reduced to produce results without depending on the engineer's



judgment as to how much slack he can take with safety, and not lose his head trying to clear some passenger train only to find that his train had parted and caused a greater delay.

At the January 20, 1914, meeting of the Western Railway Club, the subject of freight train handling was discussed. The whole evening was consumed in the discussion of air brakes versus slack in trains, but no one produced a remedy for the existing slack.

In summing up, I am satisfied, notwithstanding what has been said to the contrary, that it is still a mechanical problem and must be solved by the mechanical department, as far as running conditions are concerned—these must be made fool-proof. But, yard conditions and smashing cars on the road by careless trainmen in switching is entirely up to another department.

H. C. PRIEBE,  
Chicago Steel Car Company.

**BRACING OF BOILER HEADS**

PHILADELPHIA, Pa., July 21, 1914.

TO THE EDITOR:

I was much interested in the article of W. N. Allman, on Boiler Construction, in the March number, and the subsequent discussion of the matter in your May issue.

Mr. Allman is correct, regarding the unsupported area of back head and tube sheet, when he says that there are many views on this matter. The fact that there are many views, and that they conflict as they do, shows pretty conclusively that all cannot be right; and what follows is not written in a spirit of controversy, but from a desire to present for the benefit of others some considerations which have settled this question for me. It will be evident that the Ohio and Massachusetts state rules, deducting 3 in. from the outside of the flange to cover what the flange will carry, can only properly and consistently apply within certain limits of thickness of plate, radius of flange and pressure to be carried. It is not logical, for instance, to say that the flange of a head 1 1/4 in. thick will only carry as much as the flange of a head 5/16 in. thick. Nor is it any more rational to admit that, if a head 36 in. in diameter has a flange radius of 18 in. outside, it requires no bracing for loads proportionate to its thickness, but if the radius of the flange is 9 in. it must be braced for all its area except 3 in. around the outside, just the same as if the flange radius were 1/2 in. Similarly one need hardly state a case to see that the flange of a flat head, say 1/2 in. thick, can support a pressure of 60 lb. much further in from the flange than it can a pressure of 300 lb. with equal safety.

The formula used by the British Columbia Boiler Inspection Department has the merit of providing for each of these varying conditions, and the writer has compared it with the practice used for years by one of our largest locomotive manufacturers and finds that they substantially agree. As given in their book of boiler rules, the formula is preceded by the following statement: Segments of boiler heads above or below tubes to be supported by stays or braces. When the head is flanged and riveted to the shell, a portion of it becomes stiff enough to carry the boiler pressure without depending upon the braces. The distance that thus becomes self-supporting may be determined by the following formula: The allowance for shell as stay to head to equal

$$\frac{1}{2} \sqrt{\frac{125 \times (T + 1)^2}{\text{Pressure}}} + \text{radius of curvature of head flange,}$$

T being the thickness of the plate in sixteenths, and 125 being a constant.

For a 3/8 in. thick head, 200 lb. pressure and 1/2 in. radius flange this gives an allowance of 3 1/4 in.; while for a 1/2 in. head, 200 lb. pressure and 3 in. radius of flange the allowance becomes 6 9/16 in. When the bracing of the flat portion of the head is done by rods through from head to head, or by crow feet riveted to the head, as used to be common practice, the amounts given by this formula can be safely allowed, but should not be ex-

ceeded. When, however, as is now common practice, the flat portion of the head is braced by heavy section steel tees, even these limits may be considerably exceeded with perfect safety. This serves to illustrate the folly of attempting to govern by fixed rules a business that is still developing. Standardization is good where interchangeability is desirable, but to carry it to extremes is to entirely paralyze progress.

Consider the head of the locomotive boiler shown in Fig. 1, the radius of the flange varying from about 3 in. at the top to about 6 in. at the side center line. The drawing shows an arrangement of rods and tees for bracing the flat surface. The dot and dash line *RR* marks the edge of the radius portion and the beginning of the flat portion of the plate, and the line *DD* is taken midway between the upper row of screw stays and the lower rivets on the tees; *S1*, *S2*, *S3*, etc., indicate the segments forming the flat portion of the head, each having one or more brace rods and each being stiffened by a 6 in. by 5 1/4 in. steel tee, riveted to the head. The modulus of this tee section is 8.19 and on a 15 in. span (the distance in this case from the lower rod to the upper end of the tee) its safe distributed load is 69,920 lb., which it will be seen by what follows is much in excess of any load that can come upon it.

The area of the segment *S1* equals 187 sq. in., and at 200 lb. pressure the load upon it is 187 x 200 = 37,400 lb. The center of this load is the center of gravity of the segment, a point

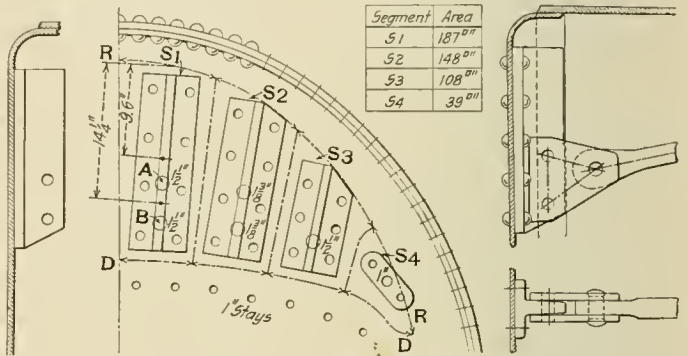

Fig. 1

Fig. 2

about 9.6 in. in from the outer edge of the flat portion of the plate and at the center of the width of the segment. The distance from the outer edge of the flat portion of the plate to the center between the two rods *A* and *B* is 14 1/4 in. Then, assuming that the plate and tee act as a lever pivoted at the most flexible place in this portion of the head, that is, just inside the line *RR*, we will have 37,400 x 9.6 ÷ 14.25 = 25,195 lb., the load at the center between the rods *A* and *B*. The combined area of these two rods, which are 1 1/2 in. in diameter, is 3,534 sq. in. Then, assuming an equal distribution of the load on both rods, we will have 25,195 ÷ 3,534 = 7,129 lb. per sq. in. on each. If, however, from various inequalities of position, length of rod or initial tension there should be 1 1/2 times as great a load on *B* as on *A*, we would have 5,703 lb. per sq. in. on *A* and 8,555 lb. per sq. in. on *B*, which is still within safe working limits, as set by the boiler inspection department of the Interstate Commerce Commission.

The load on the flange rivets is equal to 5,775 lb., the direct steam load on the radius portion of the flange opposite *S1*, plus the difference between the total load on the segment and that part of the load carried by the rods, or 5,775 + (37,400 - 25,195) = 17,980 lb. Then 17,980 ÷ 5 1/2 (the number of rivets opposite segment *S1*) = 3,270 lb. per rivet. As a 7/8 in. rivet shears at about 26,457 lb., we would have 26,457 ÷ 3,270 = 8.09 as the factor for rivet shear. The 17,980 lb. is transmitted to the rivets by a section of flange over 10 in. long, which is equivalent to about 1,798 lb. per in. of flange length.

In passing it may be noted that the 17,980 lb. which is transmitted to the flange represents the load on 90 sq. in., and as

the segment is about 10 in. wide, this amounts to transmitting the load on the outer 9 in. to the flange. The amount of load that is thus transferred to the shell through the flange may cause some minds to question whether by repeated stresses due to fluctuations of the pressure the flange may not be finally affected injuriously. An analogous case may shed the light of experience here. When a dished head is placed in a steam drum it is subjected to just such variations of load and careful measurements will show that under heavy loads such a head yields considerably. The writer recalls one case of a drum about 34 in. in diameter, whose dished head he measured under test several years ago. It was found that the dish deepened over 5/16 in. under pressure, but returned to normal on the release of the load. Under ordinary working conditions this head must give quite perceptibly, as must hundreds of other similar heads, and no trouble has developed, nor is it at all likely to, provided loads are kept within reasonable limits. As a head dished to a radius equal to its outside diameter is equal in strength to a cylindrical shell of the same thickness and diameter, if we determine the diameter of drum for which, say, a 1/2 in. steel plate is safe under a given pressure, we will have a fair idea of what is a reasonable load for a head flange 1/2 in. thick. Assuming a tensile strength of 55,000 lb. and a seam efficiency of 91 per cent, what diameter shell can we make to carry 200 lb. working pressure with a factor of five?  $Diameter = 55,000 \times 0.5 \times 2 \times 0.91 \div 5 \times 200 = 50$  in. The area of a 50 in. head is 1,963.5 sq. in. The load on the head is  $1,963.5 \times 200 = 392,700$  lb. Dividing by 157, the circumference of the flange, we obtain 2,500 lb., which is the load per inch of flange length. If we now take a load of 2,000 lb. per inch of flange length for our backheads we will surely be safe.

There are some state laws which will not admit of a load of 9,000 lb. per sq. in. on brace rods, allowing 7,000 to 8,000 lb. per sq. in. on weldless steel and only 6,000 lb. on welded iron rods. Twenty-five years' experience with boiler design convinces me that it is a serious mistake to plan rigid bracing on heads or tube sheets. The expansion of the tubes, and especially of the firebox in the case of the locomotive boiler, constitutes forces that are destructive if opposed. That is ideal bracing, which, while affording ample support against the steam load, will yet yield, as a spring does, to a greater load. The stretch of a brace rod 10 ft. long, loaded to 9,000 lb. per sq. in., is 0.036 in.; and a firebox having a crown 54 in. long at a temperature 100 deg. F. greater than the outer sheet will expand just as much. Inasmuch as greater temperature differences are probable, and crown sheets are more frequently longer than shorter than 54 in., the need of elasticity in the adjacent bracing is evident.

For a number of years it has been my habit to ask of inspectors and master mechanics the question: "Do you know of any case of boiler failure due to head or tube sheet brace rods?" and the answer has been invariably, "No." We did have in Philadelphia many years ago a boiler explosion due to the head giving way, but it was a cast iron head, and we believe unbraced at that; but since the advent of flanged steel the failures from weakness in heads have been few, if indeed there have been any.

There may still be those who think, notwithstanding what has been said, that a larger number of smaller rods distributed over the tees would be better than the arrangement shown. With three or four rods fastened to one tee, varying in length, say from 3 ft. to 12 ft., it is practically impossible for a workman to so adjust the tension on the various lengths that each will bear a proportionately equal share of the load when under pressure. It is common to consider that the deflection of the tee will equalize the loading, but when we figure the deflection between any two rod centers and find the figure in the fourth decimal place, it is evident that so small an amount is not worth considering. When there are only two rods to a tee,

however, by giving the longer rod the greater initial tension, we can successfully approximate an equalization in the loading.

An almost ideal method of bracing would be with one rod only, as shown in Fig. 2. One mild steel rod may be made large enough to carry the load, and there could be no debating the question of distribution. Welding could and should be avoided, as it would only be necessary to upset either end of the brace to form an eye. Two pieces of boiler plate would form a jaw and an equalizer combined. With a large steel rivet in the eye of the rod and two smaller ones through the web of the tee, such a construction would be as secure as a bridge. By moving the point of attachment further up or down the tee, the proportion of load carried by the rod and the head flange could be varied at will. Corrosion would bear such a small relation to the area of the brace that it would almost cease to be a factor. No doubt there will be objection made by some to transmitting so much load to one point on the shell, but there is nothing new about that. The Pennsylvania Railroad have for some years been fastening two rods to one point in the shell, the rods being attached one over the other to a bent steel plate. The writer has frequently accomplished the same purpose by the use of a piece of steel tee riveted to the shell, the rods being fastened one ahead of the other on the tee.

There is not only no reasonable objection to, but on the contrary there is a good reason for a concentration of longitudinal stress behind and before the opening in the shell at the dome. The circumferential stress at this point is transmitted diagonally on either side of the opening, and tends to pull the dome opening together longitudinally, just as it tends to stretch it circumferentially. The leakage which frequently gives trouble around the dome results from this action. If, however, we had two equal and opposite longitudinal forces at the front and back of the dome opening, and of the same magnitude as the circumferential forces at this point, there would be a complete balancing of load and no tendency to distortion. There is no danger of too much concentration of load here; the only trouble is that we cannot get enough to balance.

Any one can by a simple experiment note the effect described; take a sheet of paper, cut a liberal sized opening in it, pull in the direction of the length of the paper, and note the puckering edges around the opening. Then while you pull, get some one else to pull at right angles, and note how the sheet straightens when the tension is balanced.

Why should we waste thousands of dollars annually putting junk into a boiler? In a recent locomotive boiler design it was noted that there were 18 extra and unnecessary rods on the backhead and 10 equally unneeded rods on the front tube sheet, but what advantage to safety is this excess of strength when, out of 97 locomotive boiler failures reported by the Interstate Commerce Commission in one year, there were none due to failure by bracing, while 94 of the 97 were crown sheet failures, the other 3 being failures of lap seam shells?

THOMAS H. WALKER.

DENATURED ELECTRICITY.—An interesting method of preventing the improper use of electric current has been devised by an Italian engineer. The practice of making especially low rates for current to be used in heating and cooking devices and for electric power is becoming general, but with the ordinary constant potential current it is difficult to detect the use of lighting devices on circuits intended only for other purposes. By the use of special circuits on which the current is subject to extreme fluctuation of voltage at rapidly recurring intervals the application of this current to lamps is made practically impossible because of the flicker in the light. As the current is not entirely interrupted, however, and the normal voltage is almost immediately restored, the proper operation of power or heating apparatus is not interfered with and the rightful use of the circuits for their respective purposes is assured.—*Machinery.*



# LARGEST NON-ARTICULATED LOCOMOTIVE

Baltimore & Ohio 2-10-2 Type Has Total Weight of 406,000 lb. and Develops 84,500 lb. Tractive Effort

With the Santa Fe or 2-10-2 type locomotives built in 1912 by the Baldwin Locomotive Works for the Chicago, Burlington & Quincy\* it was believed that the limits had been reached in locomotives having a single set of drivers. A considerable advance

The boiler is of the straight top type with a combustion chamber 28 in. long and tubes 23 ft. long. The third ring in the barrel is tapered, with the slope placed on the bottom in order to give a free entry to the throat. The equipment includes

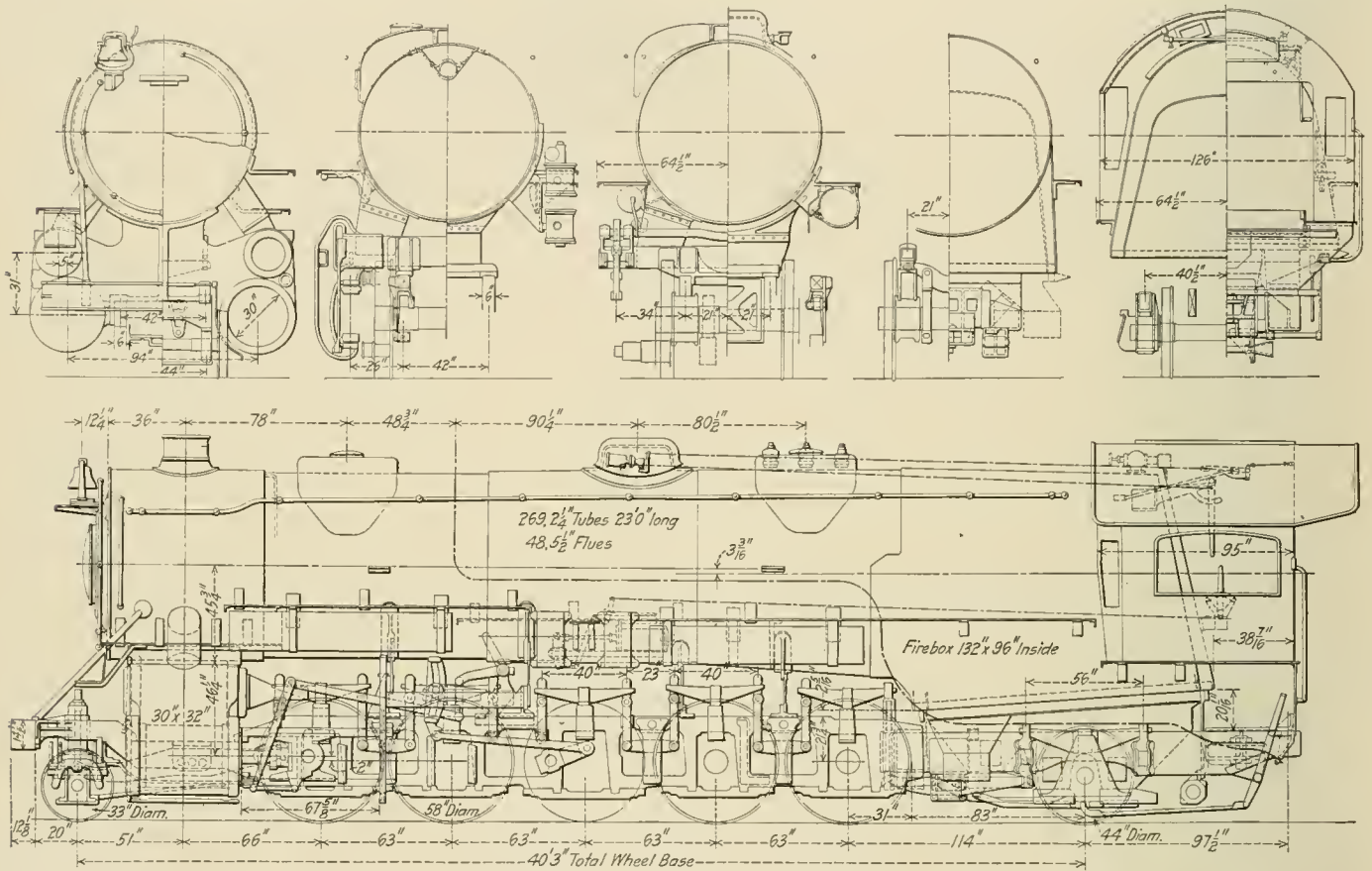

Longitudinal and Sectional Elevations, Baltimore & Ohio 2-10-2 Type Locomotive

both in total weight and in tractive effort has been made, however, in a locomotive of this type recently built by the same company for the Baltimore & Ohio. This locomotive will develop a tractive effort of 84,500 lb., which exceeds that of many Mallet articulated locomotives of the 2-6-6-2 type.

\*See *American Engineer*, May, 1912, page 31.

a Security sectional arch and a Street mechanical stoker. The superheater is of the Schmidt type, and is composed of 48 elements. The dome is of pressed steel 33 in. in diameter and 12 in. in height.

The cylinders are each cast in one piece with a half-saddle, and the castings are bolted to the smokebox and to each other



Heavy 2-10-2 Type Locomotive for the Baltimore & Ohio

by double rows of 1¼ in. bolts. The steam distribution is controlled by 16 in. piston valves, driven by Walschaert motion and set with a lead of ¼ in. The valves have a steam lap of 1¼ in., and are line and line on their exhaust edges; the Ragonnet power reverse mechanism is applied. No vacuum relief valves are used, but the cylinders are equipped with by-pass valves of the Sheedy pattern.

The cylinders and steamchests are lined with bushings of Hunt-Spiller metal, and the piston and valve packing rings are of the

extend the full depth of the frames. The rear frame sections are spliced to the main frames immediately back of the rear driving pedestals, and are braced by a steel casting which serves the triple purpose of a crossie, a support for the front end of the firebox, and a carrier for the radius bar pin of the trailing truck. The main frames have single front rails, 13 in. deep, cast integral with them.

The trailing truck is of the Hodges type, with the spring hangers placed at an angle so that they will swing in planes

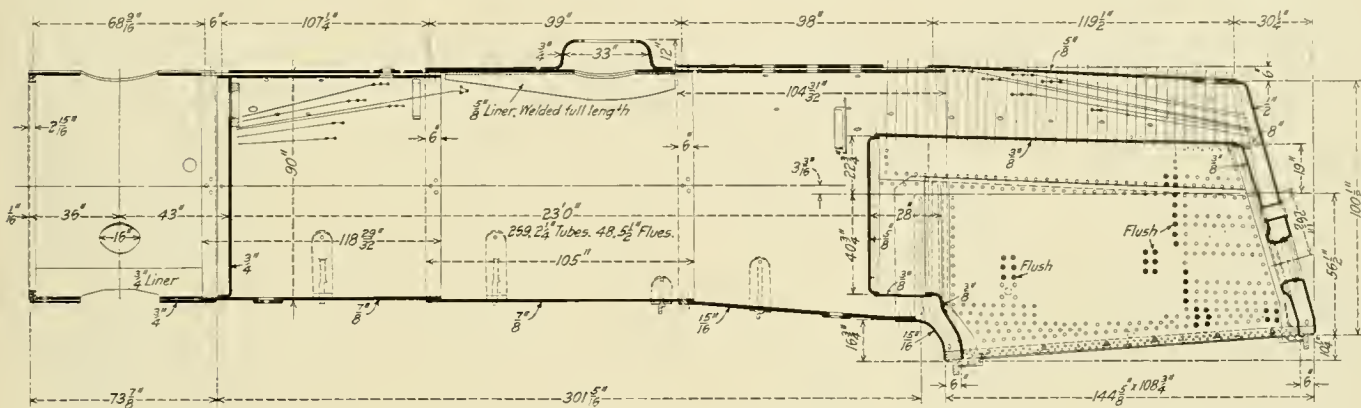

Boiler for the Baltimore & Ohio 2-10-2 Type Locomotive

same material. The pistons are steel forgings, of dished section, and are fitted with bull rings of Hunt-Spiller metal. These rings are secured to the pistons by retaining rings, which are electrically welded in place.

A total lateral play between the rails and flanges amounting to 1 in. is allowed on the front and back driving wheels, while the play on the second and fourth pairs is ¾ in. The wheels of the third or main pair have plain tires, and all the driving wheels have a lateral play of ¼ in. in the boxes. These provisions for

tangential to the arc in which the truck swings. The first and second pairs of driving wheels are equalized with the leading truck, and the three remaining pairs with the trailing truck.

In designing this locomotive, care was necessary in order to keep the overall dimensions within the specified clearance limits. The bell is mounted on the righthand side of the smokebox front, on a level with the headlight. There are four sandboxes, two for use when going ahead and two for backing up. They are mounted right and left, on the top of the boiler, and the corners

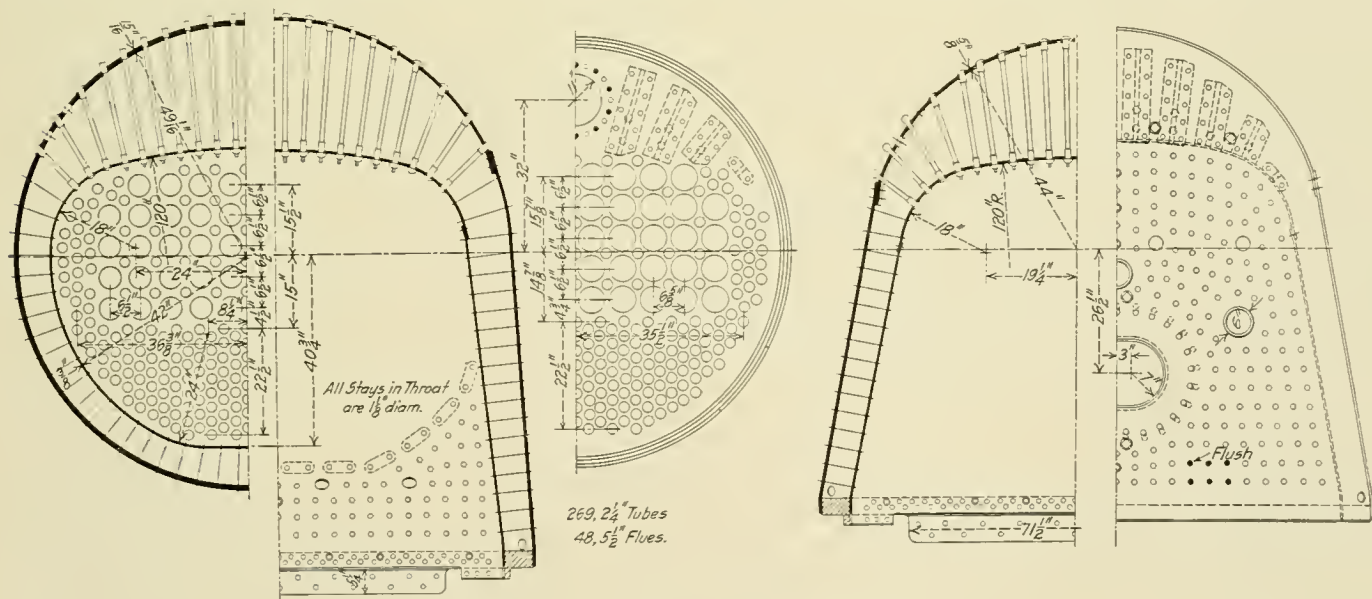

End and Sectional Elevations of the Boiler

flexibility are necessary in order that the locomotive can traverse the sharp curves on the mountain divisions of the Baltimore & Ohio.

The frames have a width of 6 in. and a depth over the driving pedestals of 7 in. The frames are braced transversely by the guide yoke and valve motion bearer; also by crossies placed respectively over the fourth pair of driving pedestals, and between the fourth and fifth pairs of driving wheels. The second and fourth pairs of pedestals are also braced by steel castings which

are rounded to keep within the tunnel clearances. For the same reason the cabroof is rounded with a comparatively short radius. The tender is of the Vanderbilt type, with capacity for 10,000 gal. of water and 16 tons of coal.

The following are the principal dimensions and data:

General Data

Gage	4 ft. 8 1/2 in.
Service	Freight
Fuel	Bit. coal
Tractive effort	84,500 lb.



Weight in working order.....	406,000 lb.
Weight on drivers.....	336,800 lb.
Weight on leading truck.....	22,700 lb.
Weight on trailing truck.....	46,500 lb.
Weight of engine and tender in working order.....	584,000 lb.
Wheel base, driving.....	21 ft. 0 in.
Wheel base, total.....	40 ft. 3 in.
Wheel base, engine and tender.....	76 ft. 6 in.

*Ratios*

Weight on drivers ÷ tractive effort.....	3.99
Total weight ÷ tractive effort.....	4.81
Tractive effort × diam. drivers ÷ total equivalent heating surface*.....	647.80
Total equivalent heating surface* ÷ grate area.....	86.00
Firebox heating surface† ÷ total equivalent heating surface,* per cent.....	4.27
Weight on drivers ÷ total equivalent heating surface*.....	44.52
Total weight ÷ total equivalent heating surface*.....	53.66
Volume both cylinders.....	26.2 cu. ft.
Total equivalent heating surface* ÷ vol. cylinders.....	288.8
Grate area ÷ vol. cylinders.....	3.36

*Cylinders*

Kind.....	Simple
Diameter and stroke.....	30 in. by 32 in.

*Valves*

Kind.....	Piston
Diameter.....	16 in.
Outside lap.....	1 1/4 in.
Inside clearance.....	Line and line
Lead in full gear.....	1/4 in.

*Wheels*

Driving, diameter over tires.....	58 in.
Driving, thickness of tires.....	4 in.
Driving journals, main, diameter and length.....	13 in. by 13 in.
Driving journals, others, diameter and length.....	11 in. by 13 in.
Engine truck wheels, diameter.....	33 in.
Engine truck, journals.....	6 in. by 10 in.
Trailing truck wheels, diameter.....	44 in.
Trailing truck, journals.....	8 in. by 14 in.

*Boiler*

Style.....	Straight top
Working pressure.....	200 lb.
Outside diameter of first ring.....	90 in.
Firebox, length and width.....	132 in. by 96 in.
Firebox plates, thickness.....	3/8 in.
Firebox, water space.....	6 in.
Tubes—number and outside diameter.....	269—2 1/4 in.
Flues, number and outside diameter.....	48—5 1/2 in.
Tubes, length.....	23 ft.
Heating surface, tubes.....	5,215 sq. ft.
Heating surface, water tubes.....	35 sq. ft.
Heating surface, firebox.....	258 sq. ft.
Heating surface, combustion chamber.....	65 sq. ft.
Heating surface, total.....	5,573 sq. ft.
Superheater heating surface.....	1,329 sq. ft.
Total equivalent heating surface*.....	7,566 sq. ft.
Grate area.....	88 sq. ft.

*Tender*

Tank.....	Vanderbilt
Wheels, diameter.....	33 in.
Journals, diameter and length.....	6 in. by 11 in.
Water capacity.....	10,000 gal.
Coal capacity.....	16 tons

\*Total equivalent heating surface = total evaporative heating surface + 1.5 times the superheating surface.  
 †Including combustion chamber heating surface.

**ABATING SMOKE AND INCREASING EFFICIENCY WITH HAND FIRING**

The following rules to aid in abating smoke and to increase efficiency with hand firing, are from Appendix IV of Bulletin No. 8, entitled, "Some Engineering Phases of Pittsburgh's Smoke Problem," issued by the University of Pittsburgh.

1. Fire evenly and regularly.
2. Fire moderate amounts of coal at a time and place the coal where it is needed.
3. Keep the fire clean, even and bright all over; do not allow it to burn into holes or thin spots.
4. Break up the lumps and have the coal as nearly as possible uniform in size. Do not fire any lumps larger than a man's fist.
5. When a fire has burned into holes, do not throw green coal on the bare grates, but push incandescent fuel into these spots before firing.
6. Regulate the draft and air supply to suit the fire.
7. Watch the condition of the fire and the steam gage together. Do not fire large quantities of coal.
8. Do not level or stir the fires unless absolutely necessary, and then use the utmost care.
9. Do not allow ashes and clinkers to accumulate on the side or bridge walls, as this cuts down the effective grate area, and causes other troubles.
10. Do not allow too long intervals between firings.

**PREDETERMINATION OF LOCOMOTIVE PERFORMANCE**

BY PROF. ARTHUR J. WOOD  
 The Pennsylvania State College

The use of the method to be discussed was first suggested in connection with problems in steam railroad operation in 1890 in Goodwin's "Railroad Engineers' Field Book." The application of the "speed-time" curves in electric railroading has been thoroughly developed by C. O. Mailloux,\* A. H. Armstrong and other engineers and the theory applied to steam road conditions was explained by "G. E." in the American Engineer and Railroad Journal, November, 1911. The method, in outline the same as used for electric railroads has been applied by the writer to a few practical cases of steam railroad operation with satisfactory results; and problems of this kind have been completely worked for the writer by S. M. Dean and by other mechanical engineering students. Attention may be called to a study of characteristic curves presented by Prof. W. E. Dalby before the Institution of Mechanical Engineers in October, 1912, and published in Engineering, November 1, 1912.

The problem before us is to find by graphical methods the

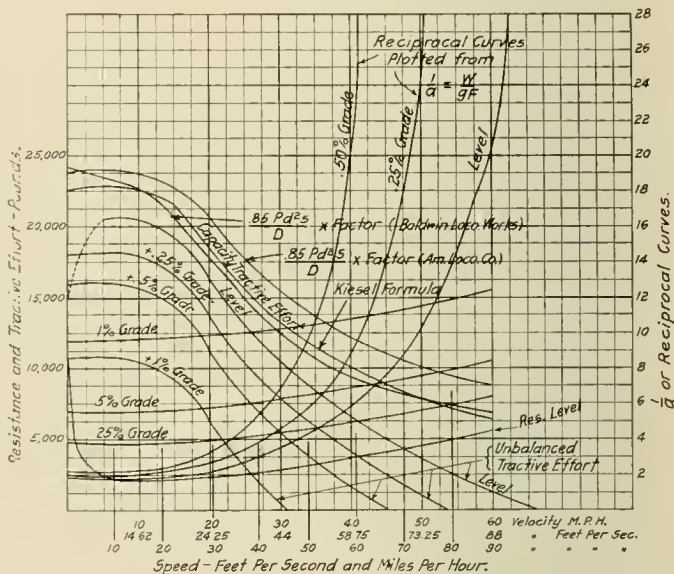

Fig. 1—Characteristic Curves

least time in which a locomotive can haul a train of known weight over a given road bed. This may readily be solved knowing only a few leading dimensions of the locomotive, the weights moved and the grades and curves over which the run is to be made. Starting with calculated tractive force at different speeds, a family of curves is drawn, easily understood and each significant in train operation.

At the outset, we find that the problem for steam railroads differs from that for electric traction in that the tractive force exerted on a train may be maintained at a nearly constant value by electric motors from start up to the normal running speed of the train. The conditions are quite different with a steam locomotive. From start up to 50 or 60 revolutions per minute, the tractive force exerted by a locomotive is practically constant, the boiler supplying steam without drop in pressure. As the speed increases, the cut-off must be reduced in order to maintain steam pressure, the result being a decrease in tractive effort. The controlling factors determining the curve of maximum tractive force in steam operation are the weight on the drivers and the maximum boiler power. The weight on drivers is the controlling factor in electric traction.

The method for solving the problem, in outline, is as follows:

\*See Transactions American Institute Electrical Engineers, Vol. XIX, 1902.

(1) Draw the tractive force and resistance curves, finding for level track and on grades the available force at different speeds behind the tender. These may properly be termed the "characteristic curves" of a locomotive.

(2) From results in (1) draw for level and for grades a "reciprocal" curve, which is a curve for different speeds, derived from the fundamental dynamic relation between the force  $F$ , acting on a mass  $M$ , producing an acceleration  $a$ , that is

$$F = Ma \text{ or } \frac{1}{a} = \frac{M}{F} = \frac{W}{Fg} = \frac{W}{F \times 32.16}$$

where  $F$ , the force, and  $W$ , the weight acted upon, must be in same units. This will be a curve drawn from the reciprocal of the acceleration for different speeds.

(3) Since velocity,  $v = at$ , the time,  $t = \frac{1}{a} \times v$  (for uniform increase in speed) represents an area, obtain the time to accelerate the train by finding the area in proper units under a limited part of the reciprocal curve.

(4) Since  $S = vt$ , obtain distance  $S$ , traveled in time  $t$ , by finding the area under the time speed curve.

(5) By aid of a profile map of the road, lay-off the time-speed and time-distance curves for the train considered, by aid of curves for level and grades in (3) and (4) above.

Speed-time curves not only show the speed attained at any given interval of time, but they also show the variations in speed occurring at various intervals of time. The slope of a speed-time curve at any time-point is an indication and a measure of the time rate of change of speed at the corresponding instant of time; and it shows whether the speed is constant, is increasing or decreasing. A horizontal speed-line indicates constant or uniform speed. An upward slope in the speed-line indicates increasing speed, or acceleration; a downward slope indicates decreasing speed or deceleration. These characteristics serve to distinguish the different kinds of speed-time curves.

A PROBLEM SOLVED

Division of road considered.....	Huntingdon to Tyrone, Pa.
	(a distance of 19.7 miles)
Locomotive used.....	Atlantic Type, E2d
Locomotive and tender, total weight.....	140 tons.
Train composed of seven steel cars	{ one B60... Passenger Car... 55 tons.
	{ one M70... Mail... 69 tons.
	{ five P70... Passenger... 306 tons.
Total.....	570 tons.
Weight on the drivers.....	61 tons.
Boiler pressure = $P$ .....	205 lb. per sq. in.
Diameter of piston = $d$ .....	20.5 in.
Diameter of drivers = $D$ .....	80 in.
Stroke piston = $s$ .....	26 in.
Total heating surface.....	2,640 sq. ft.
Steam.....	Saturated.

To illustrate the method, calculations are shown for .25 per cent grade and 30 m. p. h.

*Tractive Effort and Resistance Curves.*—It is first necessary to draw the tractive effort curve of the locomotive:

$$T. F. = \frac{.85P^2s}{D} \times \text{Speed Factor.}$$

Where  $P$  is the boiler pressure, in pounds per square inch;  $d$ , the cylinder diameter,  $s$ , the cylinder stroke, and  $D$ , the driver diameter, all in inches. This well known equation may be applied, using speed factors of the American Locomotive Company or of the Baldwin Locomotive Works. To show how they differ, both are drawn in Fig. 1. The reader should note that the above gives values of the force at the rim of the drivers and does not include internal resistances of locomotive or head-wind resistance. The writer has preferred for this study to use the formulas developed by W. F. Kiesel, assistant mechanical engineer, Pennsylvania Railroad, for both tractive force and for resistance on level and on grades.\* Mr. Kiesel's formula for the E2d class reduces to,

$$T. F. = \frac{53305}{1 + .0873V} - (22 + .15V)61 - .1V^2$$

Where  $V$  is the velocity in miles per hour, and  $T F$  the capacity tractive force or draw-bar pull behind the tender. The part to the

right of the fraction includes locomotive internal friction and wind resistance.

The resistance curves for the cars hauled were plotted from the following, which may be used for any make up of train, grade and curvature.

$$R = \text{Total resistance in pounds} = 100N + (1.5 + C + 20G)W + .01V^2$$

$(V + 16) \sqrt{WN}.$   
 $V = \text{Speed in miles per hour}$   
 $N = \text{Number of cars.}$   
 $G = \text{Grade (per cent.).}$   
 $C = \text{Curvature in degrees.}$   
 $W = \text{Total weight of cars in tons.}$

Fig. 1 shows resistance curves for level track and for three up-grades. The formula is applicable also to down-grades.

*Unbalanced Tractive Effort Curve.*—The unbalanced tractive effort at any velocity will be the difference between tractive effort values taken from the tractive effort curve and the values of resistance taken from the resistance curve. Therefore, to lay off the unbalanced or available tractive effort curves at different speeds, step off the distance between the tractive effort curve and the resistance curve for the grade in question and lay off these distances from the base line. These distances represent for different speeds the force available to accelerate the train and to overcome resistances not already taken into account. Where this curve and the base line intersect (which will be vertically below the intersection of the tractive effort and the resistance curves) will give the balancing or limiting speed, that is, the highest possible speed which could be reached, if the train runs under the conditions fixed by these intersecting curves.

*Reciprocal Curve.*—Since,

$$F = Ma, \frac{1}{a} = \frac{W}{Fg} = \frac{W}{F \times 32.16}$$

Where  $F$  is the pull or force (in pounds) from the unbalanced tractive effort curve,  $W$ , the weight in pounds of the train, including locomotive and tender, + 6 per cent of the weight of train. This additional 6 per cent takes care of the force required to overcome the inertia of the rotating parts during acceleration,

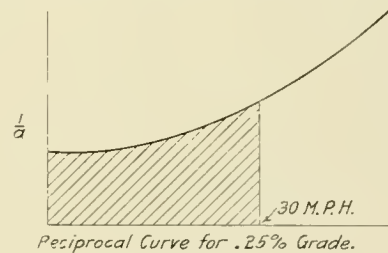

and is an average value for widely varying conditions. The reciprocal  $\frac{1}{a}$  of the acceleration is plotted for varying speed differing by ten-mile units.

*Time-Speed Curves (Fig. 2).*—The time-speed curve is used to determine the speed possible for a locomotive to haul the train in a given time. It is plotted with velocities as ordinates and corresponding time elapsed as abscissas. The time corresponding to a certain velocity is found by taking the area under the reciprocal curve between two velocities, a convenient interval being a difference of ten miles per hour. This is applying

the general equation,  $dt = \frac{1}{a} dv$ . Suppose the plot of the reciprocal of the acceleration was made so that the larger of the

unit squares into which the cross-section sheet is divided, equaled 20 (vertical scale) and the horizontal unit is five miles per hour, or 7.31 ft. per sec., as in Fig. 1. Then will the area of any one large square equal  $2 \times 7.31 = 14.62$  seconds. If a planimeter is used to determine the areas, the value of 1 sq. in. in the "seconds" units may be obtained in the same general way as when a large square on a cross-section sheet is taken as the reference unit.

The area under the .25 per cent. grade curve in Fig. 1, up to

\*See *Railway Age Gazette*, August 25, 1911, page 377.



30 m. p. h., gives a time when reduced to the proper units (as explained above) of 120 seconds, and this value is plotted as shown:

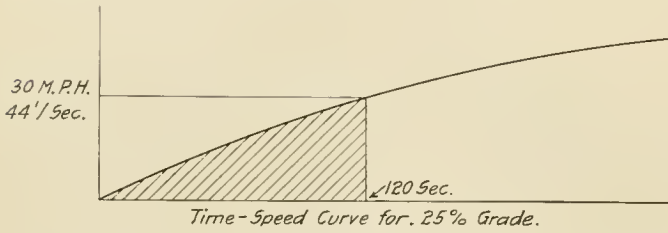

**Time-Distance Curves (Fig. 2).**—Remembering that  $dS = vdt$ , or in general for uniform acceleration  $S = vt$ , the point corresponding to the space  $S$  passed over for  $v = 30$  m. p. h. or (44 ft. per sec.) on the .25 per cent grade, may now be determined by reducing the area (to the proper scale) up to 120

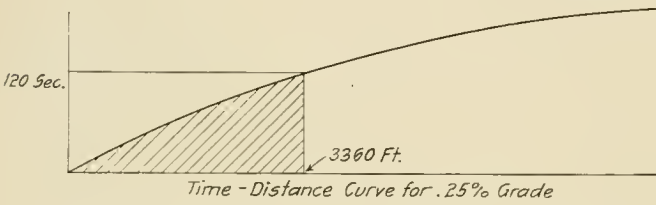

sec. on the time-speed curve. It is found to equal 3,360 ft. This is the distance run while accelerating to 30 m. p. h.

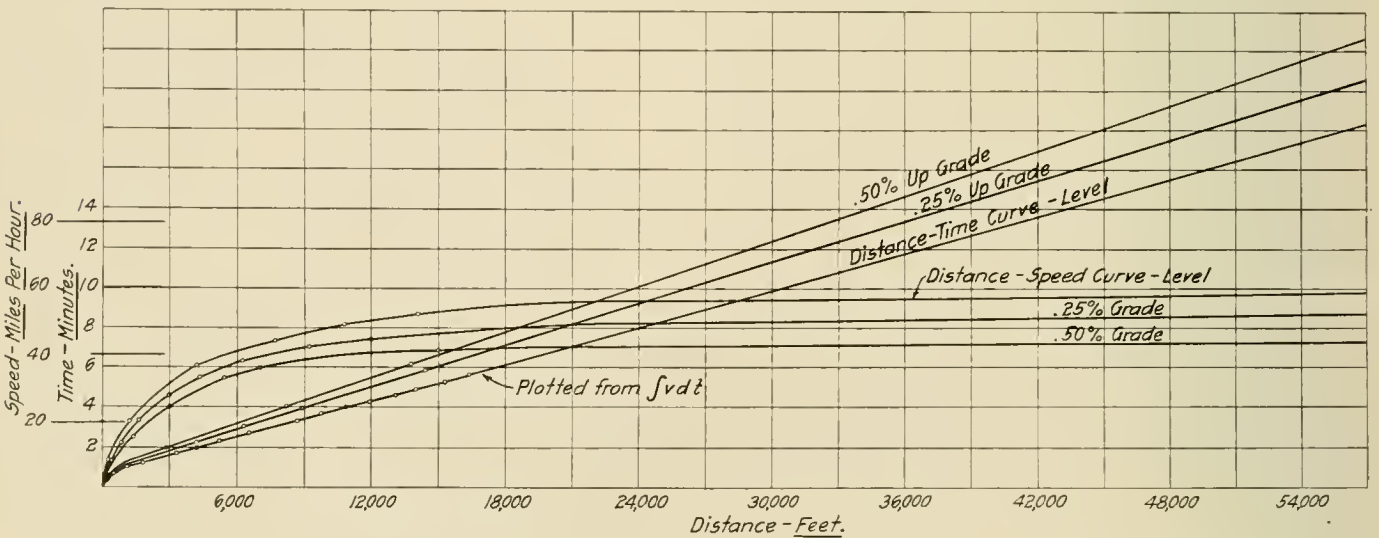
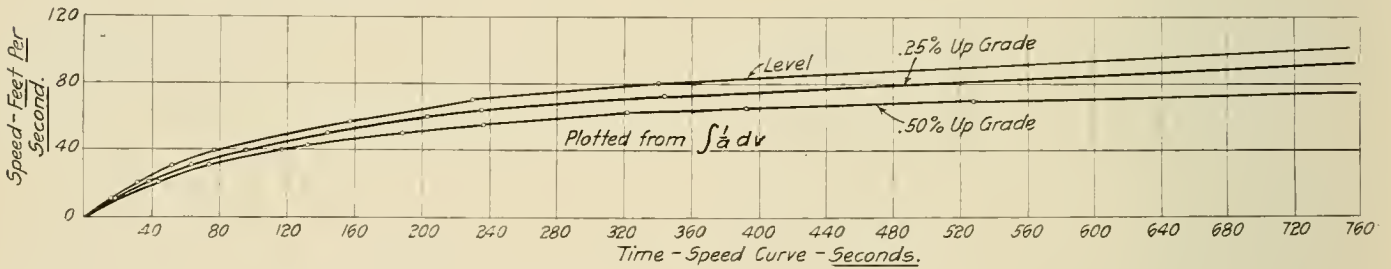

Fig. 2—Speed-Time Curves for the Train Considered

**Speed-Distance (Fig 2).**—The speed-distance curve is drawn from results obtained by above method by plotting velocities as ordinates and distances corresponding to these velocities as abscissas. The accelerating force will continue to act, increasing the speed until the limiting or balancing speed has been reached or nearly reached. However, the controlling speed over a division may not permit of as high a speed as is pos-

sible to attain, and in such case the locomotive will not be hauling to its limiting capacity. A correction may be made in such cases.

**Profile Compensated (Fig. 3).**—The profile of the grade over which the train is to run is plotted on tracing cloth using the same distance scale as was used in the time-distance and speed-distance curves. All the curves in the division must be compensated, that is, the grade reduced at the curve by such an amount that the total train resistance due to grade and curve will not exceed the maximum grade on a tangent. Each degree of curvature has been compensated to an allowance of .035 per cent in grade for each degree of curvature.

**Combining Time-Distance and Compensated Profile Curves (Fig. 3).**—The tracing cloth on which is traced the compensated profile is placed over the distance-time curve in Fig. 2 so that the intersection of the co-ordinates at zero and the start of the grade coincide. The time curve is now drawn as far as the grade remains the same, interpolating between the curves to get the grade required. The tracing cloth is then moved horizontally until the end of the curve just drawn falls on the part of the time-distance curve corresponding to the new grade. This final point on the curve will give the total time required to go the entire distance while the time to go any distance from one point to another may readily be obtained from the curve.

**Combining Speed-Distance and Profile Curves (Fig. 3).**—The tracing cloth is again placed so that the intersection of the co-ordinates at zero is made to coincide with the starting point on the profile and the speed-distance curve traced off for the given grade, interpolating between the grade curves drawn

in order to approximate to the proper grade curve. This curve is traced as far as that grade remains the same, the tracing cloth is then moved vertically until the end of the line traced coincides with the new grade curve and this curve is then traced.

The speed-distance curve will often fall very rapidly and even abruptly due to the fact that a train coming to and ascending a steeper grade than the one on which it has been running

will slow down. It is evident that it will take a certain distance to adjust its speed to the new grade conditions. To determine this distance, we may apply the formula,

$$S = 70 \frac{V_2^2 - V_1^2}{Ft}$$

Where  $S$  is the distance run (in feet) to change from higher velocity  $V_2$  (before approaching the steeper grade) to velocity  $V_1$ , these velocities being in miles per hour.  $Ft$  is the tractive force in pounds per tons obtained from the unbalanced tractive force curve for the grade being considered, and for the average of the two speeds  $V_2$  and  $V_1$ .

The results obtained by this method were checked with the

The net result has been that a few good valve gears—mostly old ideas modernized—have found their way into actual service. We may now choose from several practical types, instead of trying to make some change on the old stand-by which would make it accomplish the impossible. Any valve gear which will stand the test of five years or more of service on American roads, and continue to be specified on duplicate orders, undoubtedly has its good points. It can stand on its actual merits without claiming to have all the virtues. There is a tendency to hail every reasonably good new thing as perfect. For instance, the Walschaert was at first claimed by its promoters to give much better steam distribution than its predecessor; actual analysis proved that, with similar lap, travel and lead, one ellipse

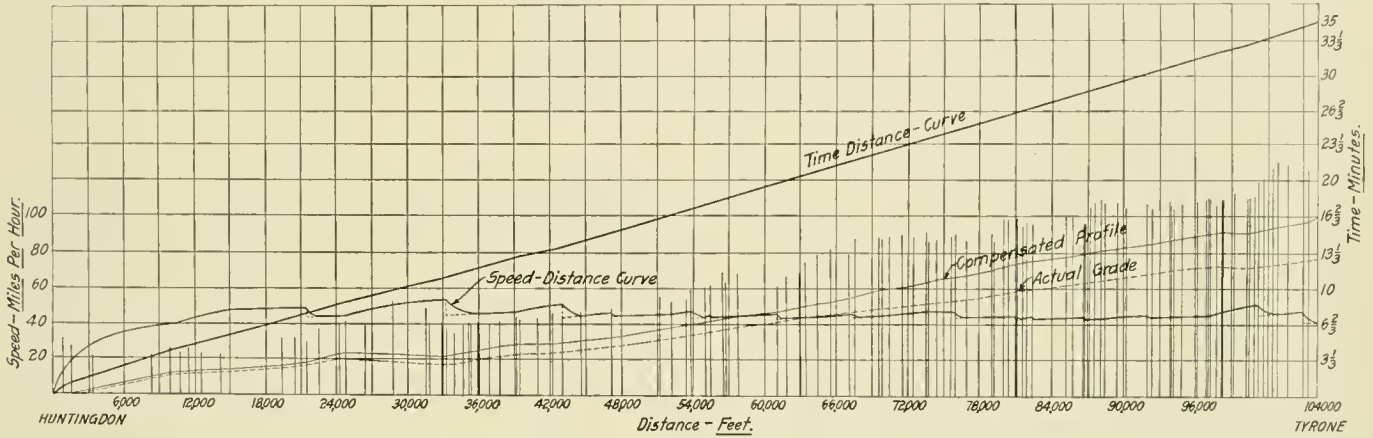

Fig. 3—Speed and Time for Points Between Huntingdon and Tyrone

actual running schedule of Train No. 21 between Huntingdon and Tyrone. Determined time as found by curves = 35 minutes. Train 21 (similar to train used in above calculations) from time table, 35 minutes.

For the analysis, here discussed, a section of track was chosen in which there are practically no down-grades or level track. The method applies equally well to such cases and also to stopping the train by application of the brakes.

## A FEW FACTS ABOUT LOCOMOTIVE VALVE GEAR

BY HAL R. STAFFORD

No mechanism connected with the modern locomotive has been the subject of so much study, discussion and experiment, and is at the same time so little understood as the valve gear. Only a few years ago we were ready to condemn unheard any type of gear other than the Stephenson. It was generally believed that this was the only one adapted to use on American railroads.

Under pressure of necessity, some intrepid spirits applied the Walschaert gear to one or two experimental locomotives. These applications were made in distinctly American style, with large bearing surfaces, and all members stiff and heavy. The gear was a success from the start, and its obvious advantages, together with the almost absolute necessity of using some type of outside gear on the enormously heavy locomotives of the day, finally broke down the barriers of reserve. After being compelled to listen to reason, we soon became ready to listen to anything on the subject of valve gear; the pendulum swung the other way. Inventors got past the office boy, and were treated with consideration within. Naturally, the feeling was that if we had been backward in trying so good a thing as the Walschaert gear, why not look still farther? A new crop of inventors came up and began to tread the well-worn paths of the thousands who in the past have helped to fill the patent office; old inventions were re-invented and old fallacies re-explored.

could be traced almost exactly upon the other. It was also landed as the engineer's friend because it "handled" so much easier, its advocates, like some of later date, forgetting that what makes a reverse lever hard to move is that you are shifting one or both valves with a given throw of lever, usually about 48 in. It is difficult to get away from the old law about the "power times the distance it moves," but every now and then an inventor claims to have evaded it. Some valve gears handle hard in the corners, and easy when hooked up; with some, as the Stephenson and Walschaert, the resistance is practically constant, provided the gear is free; but the same total work is done during the complete movement.

It will be well remembered how the constant lead of the Walschaert gear was counted as one of its greatest advantages. Now we find well known designers resorting to the subterfuge of greatly increasing the lead in back motion in order to "knock off" the lead in full forward gear, thus imitating, with considerable difficulty, one of the natural peculiarities of the discarded type.

Famous engineers, long since deceased, have told us that there was a difference, in terms of economy, of only about five per cent. between the best and the poorest of the accepted forms of valve gear. One could not have introduced the compound engine, the superheater, the brick arch, or the automatic stoker, upon a five per cent basis; inventors are compelled to speak louder than this to obtain a hearing. So, let us forget steam distribution and economy in urging our pet valve gear upon practical men; let us cease to harp on easy handling and not laud increasing lead or constant lead, but get down to brass tacks.

What has been the cause of the downfall of the so-called foreign gears in their earlier applications? The Joy motion was tried out years ago; the Allan link motion was tried on the Pennsylvania Railroad; the Walschaert was tried many times before it fell into practical hands. These gears did not stand up in service. Bearing surfaces were inadequate and parts were too light, being subject to springing and breakage. Conversely, the points that have given the Walschaert and other modern valve



gears their tremendous hold upon the railroads of today are low maintenance cost, and the faculty of "staying put"; accessibility for inspection and repairs, and simplicity of the mechanism as a whole and of its parts.

Having adopted a form of valve gear well suited to the exacting requirements of modern power, there should be banished, along with the discarded Stephenson gear, certain venerable illusions regarding valve setting. Squaring an engine has always meant equalizing the cut-off in all positions of the reverse lever, often at the expense of port opening at one end. Almost every road has some engine, or class of engines, which sounds lame even when the valve setting report is perfect. An indicator card from one of these would quite frequently show as high as 20 per cent more work in one end of the cylinder than the other, and yet the cut-off is equal; the engine is perfectly square in the accepted sense.

Very few valve gears are so well designed that both lead and cut-off can be equalized at all points of the cut-off. According to regular practice, or following positive instructions, the valve setter unhesitatingly sacrifices the former for the latter.

The rule should be, square the port opening in running cut-off, say 25 per cent cut-off for passenger service and 50 per cent cut-off for freight service, laying the blame for unequal cut-off on the designer, where it properly belongs. A difference of 2 in. in cut-off will usually be much less apparent, both in the sound of the exhaust and in the indicator card, than a difference of 1/32 in. in port opening. The reason for this should be apparent. At the higher speeds and shorter cut-offs, port opening is simply the lead plus a small increment depending on the ratio of lap and lead to valve travel. At 25 per cent cut-off, in modern engines, port opening amounts to from 1/4 in. to 3/8 in. At 70 miles an hour, with the valve open this small amount for a period about equal to the snap shot of a very fast camera shutter, it is almost inconceivable how enough steam can enter the cylinder to produce an indicator diagram. Then think of allowing the opening at one end to exceed by 1/16 in. (which may mean 25 per cent) the amount at the other. Cut-off, on the other hand, is usually a purely imaginary point on a high-speed, or even a moderate-speed locomotive indicator diagram; try to locate it, and then let some one else try. The difference between the two estimates will probably greatly exceed an amount equivalent to 2 in. on the stroke.

Steam engine slide valve motion, while it will always require more or less ingenuity in its detailed application, is in principle beautifully simple. Whatever its type, it consists of a mechanism to combine two movements, one at right angles to the other (i. e.), one must cease when the other is at its maximum and to transmit this combined movement to the valve. There are dozens of ways of accomplishing this, most of which have been tried at one time or another. Quick opening and quick closing of the ports has been the goal toward which most inventors have striven, mostly in vain. Slight gains in this respect over "straight" movement, such as the Stephenson and Walschaert, are found in some modern gears, the gain being largely at one end of the travel; but it may be accepted as a truism that any gear accomplishing this desirable feature to any appreciable extent, as measured by the coal pile, will be too expensive and too complicated for this generation, at least.

Many valve gears, highly suitable to certain special types of locomotives, have been condemned in this country because of mistakes in their early applications. Errors have been most frequently made in proportioning parts to the work to be done. Now and then new valve gears have been tried by designers with an adequate knowledge of some peculiarity of the type, as in the first applications of the Walschaert. Those responsible for these earlier designs failed to take into account the fact that, by giving the Walschaert gear a constant lead equal to the lead of the Stephenson at running cut-off, they greatly shortened the full gear cut-off, to the detriment of the starting power of the engine. This lack of starting power was for a long time

believed to be an inherent defect of the valve gear, whereas a little less lap would have overcome the difficulty.

By some builders, too much attention has been paid to theoretical considerations in designing the Walschaert gear. For instance, the location of the reverse shaft to give the best equalization of cut-off in both forward and back motion should be in front of the link, with the lifting arm extending backward. If the reach rod is then connected directly to the upper arm, the motion is forward when the block is at the top of the link. This is contrary to good practice, as in case of the failure of the reach rod, or the slipping out of the reverse lever latch, the engine might be suddenly reversed while running at high speed. In this case, as usual, the simplest arrangement is best; locate the reverse shaft convenient to the reach rod, and arrange the gear so that the slip in forward motion is minimized. In road engines, let the back motion take care of itself.

The bogey of box play, which in certain types of radial gear causes a slight distortion of the valve events, has prevented the application (except in a few special cases, where it seems to be giving entire satisfaction) of the well-known Joy motion. The same argument has been used against one of the most successful valve gears of the day. This is but a technicality. It is extremely doubtful if the momentary shortening of the cut-off at one end, compensated for by a corresponding lengthening at the other, has the slightest effect on the consumption of fuel or the drawbar pull of the locomotive.

As mentioned before, the most common error made in introducing valve gears which are used abroad is that we copy European practice in proportioning the parts, along with the idea. It should not be forgotten that American locomotives are expected to run between shoppings, which means from one to three years with only the most cursory repairs, while European locomotives receive much closer attention. Rubbing surfaces, pin bearings, etc., should be nearly double in area as compared with the best European practice, and renewable bushings used in all cases instead of take-up bearings.

## POWDERED FUEL

The following is taken from Bulletin No. 8, entitled "Some Engineering Phases of Pittsburgh's Smoke Problem," issued by the University of Pittsburgh:

The main advantages in the use of powdered fuel may be summed up as follows:

1. Complete combustion and total absence of smoke, when this process is carried out in a properly designed and operated furnace.
2. Losses due to excess air and cooling of furnaces by opening of fire doors are reduced to a minimum.
3. Use of a cheaper grade of bituminous coal, as impurities have very little effect on the successful operation of the process.
4. The ability to meet sudden changes in load, and reducing to a minimum the labor inherent to firing.

Among the disadvantages are:

1. Danger inherent to the storage of large quantities of powdered fuel, giving rise in most cities to the enactment of laws prohibiting the storage of large quantities of this fuel.
2. Inability to secure, at a moderate cost, a satisfactory material to withstand the intense heat developed when operating this type of furnace properly.
3. Tendency of the stronger drafts to carry the fuel through the furnace unburned.

The application of this process to the steam boiler has no doubt largely been hampered by the fact that the maintenance cost in daily operation is high, due to rapid deterioration of brick work. The reliability of all devices as yet applied to boilers, is questionable. It is claimed that savings of 40 per cent have been made when powdered coal was applied to metallurgical processes, such as puddling, heating and reheating furnaces, and that smokeless operation was obtained in all cases.

# CAR DEPARTMENT

## UNIFORM INSPECTION FOR SPECIAL LOADING

A pamphlet of instructions has recently been issued by the Rock Island Lines covering the uniform inspection and carding of empty box cars, the cooping of cars for grain loading, and the stripping of doors of cars loaded with flour, with a view to having the men well informed and ready to meet the heavy harvest traffic. The pamphlet represents the work of a committee composed of the assistant to the second vice-president as chairman, and other officers who are directly interested in the inspection and handling of cars for special commodities. The following extracts are taken from the pamphlet:

When empty box cars have been repaired, they should be



Method of Applying Grain Doors

inspected and carded in accordance with the following classification before leaving the repair track:

The maximum use cannot be obtained from box cars if first-class cars are loaded with commodities which damage the floor or lining, stain or saturate the floor with oil or grease, leave a stench, make unfit for carrying flour, merchandise, etc.; or which could, with safety, be loaded in a car in poorer condition or in a car of a different class.

To reduce to a minimum the difference of opinion between car inspectors, the following rules have been provided, specifically indicating the parts to be examined and conditions required to properly card cars for various classes of lading:

INSTRUCTIONS TO CAR INSPECTORS COVERING EXAMINATION OF EMPTY BOX CARS AND CONDITION REQUIRED TO PROPERLY CARD THEM FOR LOADING FLOUR, CEMENT, GRAIN AND ROUGH FREIGHT.				
Parts to be EXAMINED	For FLOOR	For CEMENT	For GRAIN	For ROUGH FREIGHT
Safety appliances.	Must be O. K.	Must be O. K.	Must be O. K.	Must be O. K.
Drift-ripping.	Must be O. K.	Must be O. K.	Must be O. K.	Must be O. K.
Posts and braces.	Must be in place and in good condition.	Must be in place and in good condition.	Must be in place and in good condition.	Requires safe running condition.
Siding.	Must not be loose, broken or decayed.	Must not be loose, broken or decayed.	Must not be loose, broken or decayed unless can be cooped.	Requires safe running condition.
Hoop.	Must be in first-class condition.	Must be in first-class condition.	Must be good, but not necessarily first-class condition.	Not necessary to be in good condition. Safe to run.
Doors.	Must be in first-class condition.	Must be in first-class condition.	Operative and safe condition.	Safe condition.
Floor and lining.	Must be in good condition, free from protruding nails and from stench, account previously having been loaded with Fertilizer, Hides, Bones, Grease, Oil, etc. Free from oil stains or saturations.	Must be in good condition.	First-class condition not necessary if cooping will make grain tight. Do not O. K. for grain if floor is loose at side sills or is oil-soaked. Must be free from stench, account having been loaded with fertilizer, hides, bones, grease, etc.	Serviceable condition.
Grain strips.	Good condition not necessary.	Good condition not necessary.	Should be in place or in condition to permit of cooping so as to make grain tight and prevent grain from pressing against side.	Not necessary.

The following instructions apply to the cooping of box cars after such inspection shows they are O. K. for bulk grain loading, or a higher class lading.

**Cleaning.**—Sweep the car clean, removing any foreign matter that may be lodged behind the lining.

**Floors.**—Carefully examine the floor for openings through

which grain might leak, particularly over the body bolster, around the draft bolts and at the intersection of the floor and the end sills, and at the end, side and door posts. (Most leaks occur over drawbars, at posts over bolsters and at door posts.)

Where openings occur in the floor, cover with coopeage paper; if at the junction of floor with posts and braces, use a pad of paper, securing it in either case by nailing a lath or board over the paper.

Where the floor shows signs of weakness over the body bolster, cover it for the entire width of the car with a piece of 48-in. coopeage paper folded to 24 in. width, securing it with lath and nails at each edge of the paper. If a similar weakness is found over the center sills between the body bolster and the end of the car, cover with paper the same as over the bolster.

Where bolt heads protrude through the floor and it is covered with paper, an additional precaution must be taken to nail a board over them.

**Grain Strips.**—Where grain strips are defective or not securely



Car with Strips Applied for Flour Shipments

fastened to the floor, apply a paper pad extending 5 in. above the floor of the car, inserting it behind the lining and securing it by nailing a lath or strip of wood over it.

**Lining.**—Cover any broken or faulty places with coopeage paper over which a piece of board should be nailed. If the size of the defects warrant, cover with paper, over which nail a grain door.

When the lining is in generally poor condition, in addition to the above mentioned cooping, the defective portion should be protected by lining with coopeage paper 48 in. wide, allowing a 6 in. lap on the floor. When applying to the end of the car, begin at the side of the car about 2 ft. from the corner, fit into the corner and extend half way across the end of the car. Apply to the other half of the end of the car in the same man-



ner, letting the ends overlap about a foot where they meet. Secure the paper with lath and nails about 3 in. from the top edge only, using but two 3d shingle nails to a lath. In order that the paper behind the laths may tear at the nails and adjust itself when grain pressure is applied, do not drive the nails up to the head.

Cover end doors with cooperage paper and nail boards over the entire opening.

*Grain Doors.*—Apply three standard grain doors to each side

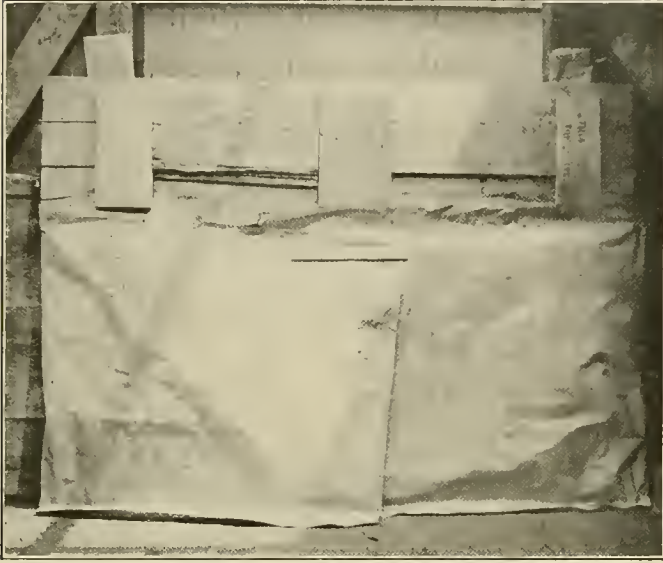

Method of Applying Grain Doors

of the door opening. Fold cooperage paper to four thicknesses, making a pad 4 in. wide on the end of a piece of paper 7 ft. long. Apply this to the inside face of the door post, allowing a few inches' lap on the floor; then place one end of the grain

so as to overlap on the inside of the grain doors, and fasten lightly at the top of the paper with lath and nails.

When applying hardwood grain doors, reinforce only cars of 80,000 lb. capacity or over, by nailing an additional grain door lengthwise over the two lower grain doors on the inside, with its lower edge about 8 in. above the floor. Apply this over cooperage paper.

When applying softwood grain doors, reinforce with two additional grain doors, apply over cooperage paper, placing the lower door about 4 in. from the floor.

*Outside Inspection—Siding.*—Inspect sides and ends, securely fastening any loose siding with 8d wire nails. Where sills are decayed, prevent leaks at siding by using a pad of paper fastened underneath with a strip of board nailed to the bottom of the sill.

*Stripping Cars Loaded with Flour.*—To prevent water damage, the side and end doors of cars loaded with flour should be tightly closed by driving a wedge between door and door-guides, after which apply a strip of 11 in. wide odorless tar water-proof paper over the sides and top of the doors, securing it with lath and nails.

## ARMORED CARS FOR MEXICO

The car shown in the illustration is one of a number used in Mexico for transporting troops. These cars were originally purchased by the Diaz government in an attempt to put down the Madero revolution. The revolutionists were constantly harassing the federal trains carrying troops and supplies, and it was found necessary to secure some type of bullet proof car.

The cars were built by the Orenstein-Arthur Koppel Company, Koppel, Pa., and are 35 ft. long and 9 ft. wide. The walls and roof are of two thicknesses of heavy steel plate with a 4 in. space between filled with sand and concrete. At the ends and sides square holes are provided, each flared at the outside so that firing can be done in any direction. The floors are steel plates covered with wood and the underframe and trucks are of exceptionally heavy construction. Accommodations for

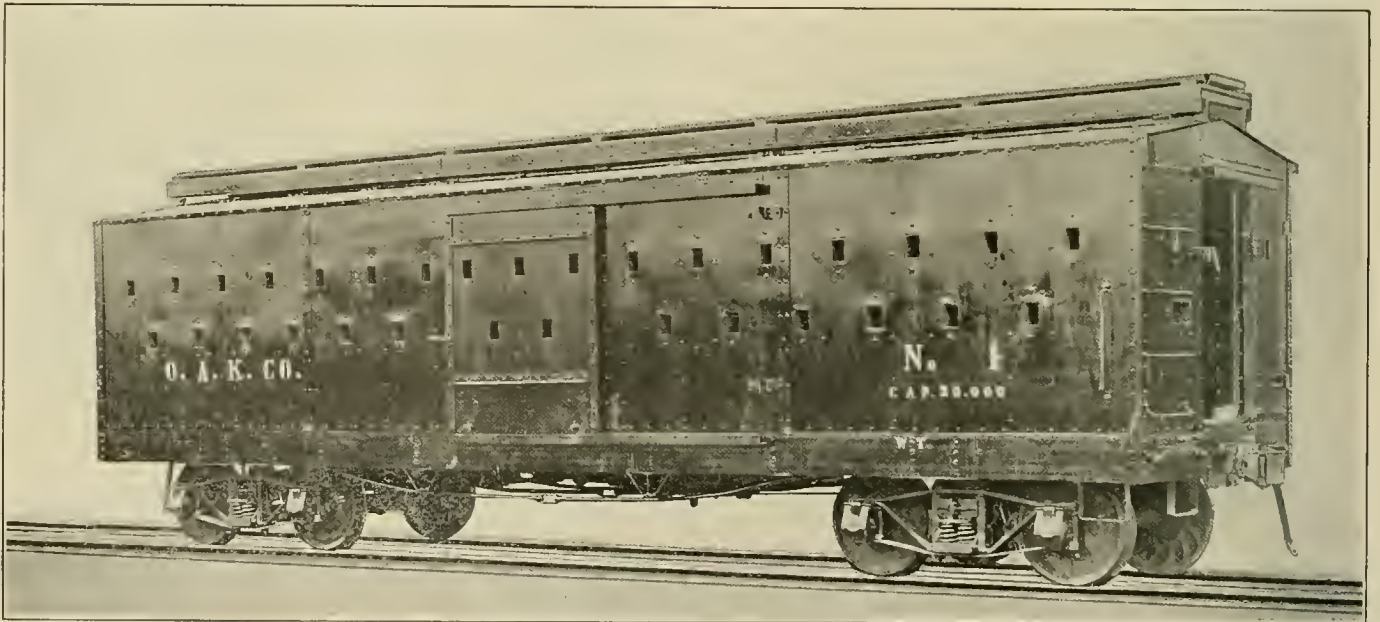

Armored Box Car Used for Transporting Troops in Mexico

door against this pad. Fold a similar piece of paper for the other door post and apply in like manner. An additional paper pad should be applied to the face of the door posts extending from the top of the pad above mentioned to the top of the grain doors; then nail the grain doors to the door posts, after which fold the loose ends of the paper extending from the door posts,

traveling are provided in the way of bunks, water appliances, etc.

The doors are comparatively small and are supported on heavy rollers. They are constructed so that when locked from the inside it is very difficult to force them open and for entering or leaving the car a ladder is provided inside, suspended from the roof by pulleys and ropes.

# IMPORTANCE OF THE DRAFT GEAR PROBLEM

As it Appears to an S. M. P., Master Car Builder,  
Car Department Foreman and Draft Gear Designer

The following four articles complete the series of twelve which were accepted for publication in connection with the draft gear competition which closed May 15. They are equally as interesting as those which were published in our July and August numbers, presenting, as they do, several unique viewpoints which were not touched upon in the previous articles. The great value of the results of the competition is in the strong expressions which it has drawn forth from the practical men who are face to face with the problem on the firing line and from the engineers and officers in charge of the design and construction—possibly a little farther removed from the actual scene of operations, but none the less interested in giving their best efforts in trying to solve one of the biggest problems confronting the railways today.

## THE ESSENTIALS OF A GOOD DRAFT GEAR

BY H. C. MAY

Superintendent Motive Power, Chicago, Indianapolis & Louisville,  
La Fayette, Ind.

It is safe to assume that 99 per cent of the men who have to do with the car repair end of the railroad business are united in the opinion that one of the prime requisites on any car is a good draft gear, not only because the draft gear is more liable to damage than any other part of the car, but also because a large proportion of other defects found on cars are the result of the use of inefficient draft gear.

Leaky roofs, stuck and damaged doors, leaking brake connections, and damaged ends, are more or less directly traceable to the inability of the draft gear to dissipate or destroy the shocks received by the coupler. The enormity of these shocks is well known, and the damage done by them is better known by the men who maintain and repair cars. Too often the investigation of injuries resultant upon using certain kinds of draft gear stops at the draft gear, and the mere cost of replacing the damaged parts is considered, scarcely any attention being paid to other parts of the car which have suffered damage from the same cause. It is now an established fact that a poor draft gear is a menace to the whole car, and a good draft gear is a protection to the whole car.

The harmful results of using poor draft gear go even further, reaching the domain of the claim agent. Many cases of damaged freight due to shifting of loads would have been prevented by the use of a good draft gear. While the opinion relative to the damage done by the use of poor draft gear, and the advisability of using good draft gear is practically unanimous, some variety of opinion may be found when the question is asked, "What are the essentials of a good draft gear?"

If the term draft gear is taken to mean the whole draft system, evidently the best draft gear is the one in which the capacities of all the parts are balanced each to the other in due proportion to the work they each are called upon to perform. If the term draft gear is taken to mean the spring, or spring and friction unit that is interposed between the coupler and the receiving parts of the car center sills, then the best draft gear will be the one that can dissipate the greatest amount of energy with the least amount of damage to itself, or the car. For want of better name this can be called the draft unit, and the parts used in connection therewith can be called draft attachments.

Whether these draft attachments be lugs or yokes, side castings and yokes, or links and keys, their mission is the same—to transmit whatever forces may be delivered by the coupler through the draft unit to the car sills, and from the car

sills to the coupler again. No arrangement of attachments can be made that will diminish any force or forces they are called upon to transmit, and their required capacity and consequent strength will depend entirely upon the draft unit used, as the attachments must be of sufficient capacity to transmit the difference between the absorbing capacity of the draft unit and the total force delivered to the coupler. By this it will be seen that the critical element in any draft gear system is not the attachments, but the draft unit, and it follows as a necessary corollary that the weakest draft unit needs the strongest attachments. The draft unit being the critical point in the draft system its selection should be a matter of greater consideration and closer investigation than the selection or arrangement of attachments. This statement is not intended to minimize the importance of proper attachments, but to emphasize the greater importance of the draft gear unit.

The greater importance of the draft unit being conceded, an examination of its purposes and effects can follow. To repeat what has been stated before in another form, the draft unit is that part of the draft system that is interposed between the coupler and the receiving parts of the car center sills. Its principal characteristic is resiliency and its function is to minimize to the greatest possible degree the injurious effects of sudden and violent shocks applied to the coupler. Broadly speaking, there are two kinds of draft units, spring and frictional, though there are some spring units that claim frictional properties and all friction units employ springs.

The spring unit is too well known to waste words in its description and only requires examination. The spring unit most commonly used consists of two springs, 8 in. in diameter and  $7\frac{3}{8}$  in. in height, generally known as M. C. B. Class "G." Their combined capacity is 60,000 lb. under a static test and the difference between their free and solid height is  $2\frac{1}{2}$  in. Several combinations involving their use have been arranged and as a general case, whatever the arrangements, the springs are so applied that a movement of  $1\frac{3}{4}$  in. is secured, thus obtaining the full capacity of the springs. When this  $1\frac{3}{4}$  in. movement is ended the attachments receive the load. It makes no difference what the combination may be, nor how ingenious and powerful the attachments may be, the limit of its capacity as a draft unit is its capacity considered as two springs, which is 60,000 lb.

Sudden and violent shocks that develop an impact force of 300,000 lb. are by no means uncommon in switching service, and according to the rule stated previously, that "the attachments must be of sufficient capacity to transmit the difference between the absorbing capacity of the draft unit and the total force delivered to the coupler," it follows that the attachments must be capable of receiving and transmitting a force of 240,000 lb., which in itself is sufficient to cause much damage to car and loading, even though the attachments may be strong enough to perform their mission. For this reason attachments for spring draft units have been and must be very heavy and strongly secured. The force of 60,000 lb. used in compressing the spring unit, though it has reduced the total force moving in the direction of spring closure, is still alive and operates with destructive effect when the cause of the original shock is removed and normal conditions are restored. The spring unit is but a storehouse for the amount of force used to compress it a given distance, which force is given out when the power causing the compression is removed. This reaction, or recoil, as it is generally termed, continues in a series of actions and reactions diminishing in force with each vibration until the springs reach quiescence.



The result is a succession of quick, snappy blows producing much damage.

The unsatisfactory service rendered by spring draft units led to the invention of units in which frictional resistance, obtained by metallic surfaces rubbing together under pressure of springs, is used to increase capacity. All frictional draft units are based on the fundamental principle of causing all or a part of the energy developed by the force of a blow or movement to dissipate itself by performing work on its way from the coupler to the receiving parts of the car center sills. The amount of work that can be performed in this manner varies with the types of units used, and ranges from 150,000 lb. to 260,000 lb.

Two general types of friction draft units are in common use. In the first type the frictional elements and springs are contained within a cylinder, the walls of the cylinder forming a part of the frictional system. In this type the sequence of events in the operation of the gear is through the spring to the friction elements, and it follows there must be some movement of the spring before the friction elements operate. As wear ensues, due to constant operation, this preliminary movement increases, reducing the efficiency of the gear in proportion to the amount of preliminary spring operation. Objection is frequently made to friction draft units of this type on account of their enclosed form preventing proper inspection and replacement of damaged parts. Through the same feature of their construction, no adjustment to compensate for wear of parts is possible.

In the second type the frictional elements are contained in a divided case, the case occupying the same position relative to the yoke and coupler as the spring unit in a spring gear, or the cylinder in the above mentioned frictional unit system. Springs are used in connection with the frictional elements to obtain the desired results. They are not confined within the case as in the previous type, but are applied and adjusted independently. The sequence of events in the operation of this type of friction unit is the reverse of those belonging to the cylinder type of frictional unit, being through the friction elements to the springs so that there is no preliminary spring action whatever. All the parts liable to damage are exposed and subject to inspection; compensation for wear of parts is readily and easily made, rendering it possible to keep the gear up to its full capacity at all times. The static capacity of draft units of this type ranges from 200,000 lb. to 260,000 lb.

Repeating again the rule that the attachments must be of sufficient capacity to transmit the difference between the absorbing capacity of the draft unit and the total force delivered to the coupler, and assuming again an impact force of 300,000 lb., the attachments must then have a capacity of 40,000 lb. to 100,000 lb. as against a capacity of 240,000 lb. for the spring gear. It must further be kept in mind that whatever force is delivered to the attachments is also delivered to the car and the tendency to disturb anything on the car or in the car is diminished in like proportion.

Whether the injuries to cars are caused by a few violent shocks or by a constant succession of smaller shocks is a question that had been a subject of debate for some time and possibly will continue to be such for some time to come. There is, however, no doubt that damage and costly damage occurs somehow; couplers are broken, yokes are fractured and bent, yoke rivets sheared, roofs strained and distorted, doors jammed and broken, sills bent, rivets sheared, lading shifted with damage to itself and the car superstructure—the greater part, if not all of which damage can be eliminated by the use of a proper draft gear, a draft gear that will dissipate and destroy the shocks instead of transmitting them through the car. No good can possibly be accomplished by making the couplers, yokes, attachments, etc., heavier. That only intensifies the burden.

A car is either an asset or a burden to the company owning

it; an asset when it is carrying revenue producing freight; a burden when it is on the repair track. Seventy-five per cent of the repairs on freight cars are made necessary by weak draft gear. A good draft gear is a revenue producer and a burden reducer. "The draft unit is the critical point of the car," and "the essential part of a good draft gear."

## REPAIR TRACK MILEAGE DOES NOT PAY DIVIDENDS

BY F. H. SWERINGEN

Master Car Builder, Streets Western Stable-Car Line, Chicago

There is no question but that cars can be built strong enough to carry the load according to the stenciled capacity, but cars do not fail to any extent from the vertical load; if placed under load on a storage track the physical condition of the car would remain the same for an indefinite period of time. But cars are failing and bad-order cars are increasing in abnormal numbers. The nature of the failures leaves no room for doubt as to the cause.

Through the introduction of gravity yards and Mallet locomotives; congested terminals, making it necessary to switch cars at a high rate of speed, and more powerful switch engines, conditions never before experienced in the history of railroading have been brought about. These conditions have paved the way for enormous shocks due to pulling, buffing and recoil. These shocks and the fact that the cars are largely equipped with spring draft gear, affording very little protection to the car, are responsible for the abnormal increase in the number of bad-order cars; the cars are being pounded almost into a state of destruction.

The following list of failures, which are found to exist on cars all over the country, verifies the foregoing statement: Broken draft spring followers, follower stops, coupler yokes and rivets, draft timbers and bolts, end sills, dead-woods, couplers and their attachments, bent draft sills, loads shifting through the end of the car, roofs shifting, siding raked, and other defects resulting from shock where the spring draft gear fails to do its duty. Should this statement be doubted one visit to any of the various repair tracks and scrap piles or the checking up of the repair bills for any one month will verify it.

Special analysis of repair bills reveals the fact that 75 per cent of the repairs to freight cars is due to draft gear failures. In making this analysis no account was taken of shifting loads; ends bursted out; and roofs, running boards and siding raked. The spring draft gear, being responsible for 75 per cent of the total failures to the car to which it is attached, conclusively demonstrates the weakest spot and the one needing immediate attention in order to reduce the abnormal number of bad-order cars, thus keeping the cars in service and making them participate in paying dividends to the owner.

Capacity is one of the things most desired in railroad equipment. The capacity of a car has been doubled within the last ten years, consequently each part of the entire structure affected by the increased load should be strengthened accordingly. The selection of the draft gear and the manner of its application are of vital importance. The draft gear that fails to develop a high capacity with a minimum amount of recoil spells destruction for the car and reduces the dividends according to the failures for which it is responsible. For many years high capacity draft gears have been in course of development. The draft gear manufacturer has spared neither time nor expense in placing on the market friction draft gears that develop a high absorbing capacity, and which will, if used, destroy the effects of the majority of shocks. Through the use of the spring draft gear the effects of the shocks are not destroyed.

Many of the leading railroads and private car companies are now using friction draft gear on both new and old equipment. In doing so they find that they have greatly reduced the maintenance cost of their equipment as well as loss and damage to lading. Quoting F. F. Gaines, superintendent motive power of

the Central of Georgia, in the April, 1913, issue of the Railway Age Gazette, Mechanical Edition: "In rebuilding wooden coal cars, metal draft arms, engaging the steel body bolster so as to re-enforce the center sills at this point, were applied in connection with a substantial friction draft gear. These cars have been in service about three years without any cost for repairs to couplers or draft gears." The results obtained by Mr. Gaines can be accomplished by any railroad company adopting a high grade friction draft gear.

The mechanical department furnishes the operating department with equipment in condition to handle the business at a minimum maintenance cost and with the least delay. So far as the other departments are concerned the mechanical department is the sole owner of the car, being responsible for its condition at all times. When the car fails, account of bad-order, it is not the general manager that gets the "jacking" up, but the mechanical officer. Consequently it is of vital importance for him to equip the cars with the best device which will keep them in service. Every cent spent in repairs to cars must be taken from the earnings of the company, thus reducing the dividends accordingly. The mechanical department does not participate in creating a revenue in any form other than through the economical management of its department.

We find that the majority of car failures are due to the inefficient draft gear. In order to increase the dividends, reduce repair track mileage and keep the cars in service, use a friction draft gear that will protect the car against the element of shock which is responsible for its defective condition.

Which is the most efficient draft gear in use? The most efficient draft gear is the one that has the least amount of recoil, will not shear rivets, prevents deflection of center sills and is constructed as nearly mechanically correct as it is possible to build it. To comply with these requirements it should be so constructed that the car inspector can inspect all parts at any and all times in the same way as he inspects the remainder of the car. This is impossible if the working parts are confined within the walls of a barrel or casement; in event of failure of either springs or friction elements the gear is liable to remain in that condition until the car is placed on the repair track for general repairs. If the draft gear had not failed it might not have been necessary to place it on the repair track for general overhauling.

The spring is the foundation of any draft gear, either spring or friction. If the location of the spring is such that it can be removed at any time that it may fail, without disturbing any other part of the gear, or taking the car out of service; in other words, being able to replace it as easily as to replace an air hose or an injured bearing, the gear must then be mechanically correct in this respect, as with this construction it guarantees the keeping of the draft gear up to its highest state of efficiency at all times. There is only one friction draft gear, to my knowledge, that contains this feature.

All draft gears develop slack if they do any work. The only method of taking up slack on most draft gears is through the introduction of slack followers. The coupler travel is reduced according to the thickness of the follower used and in consequence the capacity of the gear is also reduced. The longer the coupler travel the greater the capacity of the gear. When the horn of the coupler engages the striking plate the draft gear is at rest; the coupler horn becomes the draft gear and the car receives the shock. There is a friction draft gear so designed that it affords an adjustment which provides for the taking up of the slack, and through this adjustment the original coupler travel is always maintained, compelling the draft gear to do the work it is intended to do throughout the life of the car.

Most of all other devices used in car construction, such as brake beams, couplers, knuckles and knuckle pins, are submitted to a physical test before purchase; yet the draft gear, the most important device, is purchased without being tested. Some of the leading draft gear manufacturers have placed at the

disposal of the railroad man laboratories equipped with devices for the testing of the draft gear. The same information can be obtained by testing the draft gear that is obtained by testing all other parts mentioned above.

Summing up, in selecting a draft gear the one which should be used is the one which will dissipate the greatest shock, develop the least amount of recoil, and yet be mechanically constructed to protect itself as well as the car, thereby reducing the repair track mileage to a minimum and increasing the dividends by keeping the car at work.

## THE DRAFT GEAR PROBLEM

BY WILLIAM SCHMALZIND

Foreman Car Department, Texas & Pacific, Fort Worth, Tex.

At the time the automatic coupler was introduced to replace the link and pin method of coupling cars, a single spring of 19,000 lb. capacity was placed back of the coupler to act as a cushion for any blow or shock received. There were cases also where two springs were used. The cars were of wood construction of light capacity and were handled in trains of short length. The locomotives had a tractive effort of about 12,000 lb. As the demand for longer trains and larger cars became greater it was found that the cushion offered by this light draft spring was insufficient and it was necessary to increase the capacity to 30,000 lb. As far as cushioning the blow was concerned, the increase in capacity was thought sufficient, but there was another feature that had to be taken care of, and that was the recoil. This caused the train to part because of the failure of the coupler to stand the quick snap.

With this great barrier confronting the progress towards longer and heavier trains, it was necessary to design a device that would have a higher capacity than was possible with springs alone and have little or no recoil. The friction draft gear was introduced. This was twenty-six years ago. Is it not apparent that proper attention has not been given to the draft gear, since we have cars of 100,000 lb. capacity in service which are equipped with the spring draft rigging of twenty-five years ago?

There are certain items on a car that are expected to be renewed, such as wheels, brake shoes, axles, journal bearings, air brakes, paint and lubrication. But in addition money must be spent for damage to the car. There may have been required a new coupler, a new end, a new draft sill or end sill, aside from claims paid for the destruction or damage of valuable lading that the car contained. When we consider the nature of these damages, we come to the conclusion that the car was struck by another car in switching, or was subjected to a shock in train service that the draft gear was not capable of absorbing. Let us assume that the car when new cost in the neighborhood of \$1,000. This \$1,000 was to be protected or insured by the device placed back of the coupler to take care of the blows or shocks. Suppose it consisted of a pair of springs of 30,000 lb. capacity and cost a few dollars less than the best insurance obtainable; would it not have been a saving to have spent a few dollars more and have the best for a longer time and prolong the earning capacity of the car by keeping it off the repair track?

We know that in actual train service, blows or shocks have been registered as high as five and six hundred thousand pounds. A device of fifty thousand pounds capacity will take care only of fifty thousand pounds, and the remainder of the shock goes to the car, does the damage above mentioned, and puts the car in for repairs and stops its earning capacity. Money is lost in repairs and idleness for money saved on the first cost of a device that was not worth what was paid for it.

Cars are being constructed today of steel, and many with steel underframes, in order that they may better withstand hard service than a car of all-wood. Is it not advisable to



have the best possible device to take care of the shocks that the wooden car absorbed to a certain extent in the elasticity of its bolts and timbers?

The time is rapidly approaching when the wooden car will have passed out of existence and we will have trains made up of all-steel cars. When that time comes, what is going to be called upon to destroy the shock and protect the steel car and its lading, or both? The shock must be absorbed rather than stored up and returned in the form of recoil.

A non-recoil friction draft gear is the only solution. In selecting a draft gear, the construction should be considered first; second, the capacity, and third, the time limit of its action. The latter is a very important factor. There are different types of friction draft gear on the market, having high capacity, but the travel, or time limit of action, is so small that the capacity is of no advantage because of the fact that the gear is too stiff, or, in other words, the blow has not time enough to be absorbed in friction.

There is another advantage to be gained by the use of a first class friction draft gear, and that is the time saved in inspection in interchange. Time saved in delay to traffic is money saved, and as the inspector goes along from car to car inspecting the equipment, it is quite to his advantage if the inspection can be made easily and with despatch. A draft gear that can be seen without question of its being in good working order or not, is a great advantage. There are draft gears that are so contained between the sills of a car that it is just about impossible to know whether they are intact and doing the work or not. A car may be equipped with such a device and the device may be out of commission as far as its protective merits are concerned, and still be passed by the inspector time and again. The car will continue in service until it becomes necessary to hold it, remove the parts incasing the gear, and find the trouble.

The necessity of taking up slack in a draft gear is also of importance, as the parts will wear.

It is practically impossible to know what the shocks amount to until we see the damage done to a car that was designed to take a great shock in itself without the consideration of draft gear protection, so to speak. While the car may be of all-steel, it will not absolutely take care of, or pass off, a great shock or a continuance of shocks without being distorted or failing at some point in its make-up. There are parts of cars being damaged today, due to shocks, that people do not attribute to the inadequacy of the draft gear, as long as the draft gear is not damaged to a point of uselessness.

It is quite reasonable to believe that if the coupler does not have something behind it to take the shocks it will eventually be damaged. Then again, if the coupler is increased in size and weight it will mean the constant failing of some weaker part of the car in turn, making an endless chain of failures. Most everyone will agree that with the best friction draft gear, of the longest possible travel and highest capacity, we could cut in half the amount of money and grief we are spending on couplers.

This particular assertion calls to mind the fact that at one railroad terminal alone an average of 300 couplers a month are replaced. This is only one terminal among hundreds that are using the same number or perhaps more.

Some people are of the opinion that a test of draft gear at a laboratory, or other than an actual service test, is not a proof of merit. We will agree that a laboratory test is not a service test, but it is getting somewhere near to what you want to find out, and as far as the comparison of the devices is concerned, we will at least know if they will stand up in a less severe service than actual train service. Couplers, knuckles, knuckle pins, brake-beams, etc., are tested to do a certain work before being purchased, but the draft gear that is to protect these parts receives the least consideration.

FRICITION DRAFT GEAR\*

BY GEORGE L. HARVEY  
Mechanical Engineer, Chicago

First see that the car is properly equipped to hold the friction draft gear, and to stand the stresses of modern service. The drawbar should be a heavy steel bar with a 5 in. x 7 in. shank, and the bar should have 1¼ in. clearance sidewise and ¾ in. top clearance. If a flat carrier iron is used, not less than 1 in. x 3½ in., there should be two 1¼ in. and two ¾ in. bolts, one of each on each side of the bar. The downward hammer blow is quite heavy, and many gears are improperly equipped in this respect. The malleable iron type of carrier iron is very good, with a horizontal 1¼ in. bolt passing through it, thus using one bolt for the carrier iron and putting it in shear. In addition it ties the draft arms at this point.

The deadwood should be of cast steel, and it is all-important that the horn of the coupler should not strike it. The full strain of the buffing should come through the draft gear, and be partially absorbed by it and partially transmitted through the center sills. The horn of the coupler should be ⅜ in. from the deadwood when the gear is closed. A friction gear that will not stand these full shocks of service is not suitable for the purpose for which it is intended.

ULTIMATE STRENGTH OF DRAFT GEAR

I consider 600,000 lb. as the load on which to base the calculations for draft gear stresses. Sometimes they exceed this, but rarely, and the factor of safety provided in the size of center sills will generally take care of any higher loads than this. A friction gear should be able to carry a static load of 600,000 lb. without injury. Some advocate a gear which closes at 150,000 or 200,000 lb., with the idea that any additional strain will pass through the horn of the coupler and the center sills, and claim that a static test of 600,000 lb. on the gear is an unfair requirement. Let the friction gear take the blow! It is better to smash the draft gear than the car.

In making a test with 600,000 lb. loads on draft gears they should be measured carefully before they are put in the testing machine. Measure the height on both sides of the gear, also the diameter of the barrels, and after the test take the measurements again. The friction spring gear (Harvey) is made of tough tempered steel, and when the spring is closed 600,000 lb. or more can be placed on it without injury. When the spring is closed at, say, 180,000 to 225,000 lb., there is no more strain thrown on the friction member, as the inner main coil is closed solid, and none of the excess load above the closing load is thrown on the outer friction spring coil member.

*Ultimate Strength Tests.*—These tests were made to show the ultimate strength of several different kinds of draft gear, the tests being made by Prof. Gebhardt, of the Armour Institute. All the gears were submitted to loads of 600,000 lb. in the static testing machine, and the results obtained were as follows:

Gear	Set	Spread	Remarks
A.....	7/16 in.	1/16 in.	.....
B.....	3/16 in.	¾ in.	.....
C.....	0 in.	0 in.	Perfect condition
D.....	½ in.	....	Barrel cracked 5 in.

*Eccentric Loads.*—The 60,000 lb. laboratory test is fair, in a way, but it does not take care of eccentric loading. When the cars are bumped together the gears do not close square, but almost always eccentrically. When two couplers come together they kick sidewise 1¼ in., and the butt of the coupler may be thrown off the center line about ¾ in., so that it strikes the front stop. It is evident that the drawbar itself will thus be thrown 2 in. out of line when the cars are coupled. This will

\*Mr. Harvey is the designer of the Harvey friction spring draft gear and prepared a most excellent and voluminous contribution to the draft gear competition. In editing it to come within the limits of the space available for its presentation, certain portions referring more particularly to the special claims for this particular gear and the design and construction of its details, have been cut out or condensed. Names have been omitted where a direct comparison is made with other gears. In fairness to Mr. Harvey it should be remembered, therefore, that the article as it appears is little more than an abstract of the original paper.

twist the front follower and throw an eccentric load on the gear. It would probably be more proper to test all gears with an eccentric load, using a bevel plate, beveled say  $\frac{1}{4}$  in. in one foot. This would then give a static load on the gear somewhat similar to that which is found in service. The great difficulty with all laboratory tests is to make them resemble service conditions.

The rear draft lugs should be made longer than the standard MCB lug. There is no reason why they should not be made 50 per cent longer, with a butt plate behind the lug, running to the bolster.

The sills should be prevented from spreading with a substantial tie strap, say  $\frac{3}{4}$  in. x 6 in., with two  $\frac{7}{8}$  in. bolts at each end. The tie straps should be hooked up over the sills, and for long gears two straps should be used. Many tie straps are bent downward to pass under the yoke, but this is not a good practice, as the straps tend to straighten out.

*Center Sill Area.*—Center sills on steel cars should have not less than 26 sq. in. of metal in cross section; the area of both center sills and the cover plate is included in this figure. Charles Lindstrom, chief engineer of the Pressed Steel Car Company, has for years advocated designing steel cars so that the center sills would stand a compression of 500,000 lb. From this he determines that the area of the center sills should be 23 sq. in. in order successfully to stand the working strains of train service. Center sills so designed will, of course, stand a much higher load before failure.

The center line of draft should be placed about 2 in. or 3 in. above the bottom of the center sills. If steel draft arms are used, the metal should be about  $\frac{9}{16}$  in. thick and a splice made back of the bolster, although some prefer to splice the sills in front of the bolster, as in case of a breakdown they assume there would be less damage to the bolsters. Filler plates can be put in back of these splices, running to the bolster, in order to stiffen the gear and the bottom edge of the center sills should be covered with a plate from a point just back of the rear draft lugs back to the bolster.

*Follower Support.*—All gears should have the followers supported on guides. This will cause the yoke to hang down on top of the followers, and be free at the bottom edge of the follower. If the yoke is supported, and the followers lie on it with the gear, there is a clearance at the top of the followers. When you pull on a draft gear, and the drawbar is raised up at the same time, if there is no clearance at the bottom of the followers, there is a tendency for the yoke to pull off the head of the drawbar rivets, which is not the case when the ends of the followers are supported on guides. If a bent plate is used for lower guide and tie strap, care should be taken that there is ample side clearance. All nuts should be secured with grip nuts.

Many people think that if a gear shows well on a wooden car it is satisfactory for a steel car. Such an inference is far from correct. In wooden cars the sills and the whole car structure yield and absorb a large part of the blow, whereas the steel car is so rigid that the gear which might answer the purpose on a wooden car would certainly not stand up satisfactorily.

#### THE IMPORTANCE OF FRICTION DRAFT GEAR

J. C. Fritts, master car builder of the Delaware, Lackawanna & Western, presented a very good paper on "Freight Car Troubles" at the Central Railroad Club meeting in September, 1913. He was frank to admit that he had not realized the importance of the draft gear problem, and said: "I am free to confess that up to the time I started to investigate this question some time ago I did not credit it (friction draft gear) as being such an important factor in the question of car maintenance and other expenses incidental to car failures."

The data compiled by Mr. Fritts is unusually interesting. Among other things he said: "In an examination of 1,500 cars equipped with spring gears, and 4,805 cars equipped with friction gears, the number of failures of couplers, pockets, rivets, followers and other parts was 64 per cent. less in favor of cars

equipped with friction devices." This is a pretty broad statement. He examined a sufficient number of cars with sufficient detail to obtain a fair idea of the proposition. Any one that will read that article and say that the friction draft gear is not essential for the proper operation of a railroad is certainly making a great mistake.

Some people think it is far-fetched to charge roof repairs as due to draft gear troubles; some do not. There are many repairs required on cars that are due to draft gear weakness that are not charged to it. The enormous amount of repairs required on draft rigging almost staggers one. One road required last year 108,000 pieces of center sills, and 148,000 oak draft arms. The cost of this material alone is a stupendous figure, but when you take into account the other damages to the car and the cost of putting the sills on the cars and the delays to service, etc., you can imagine what the expenses to this road have been, due to ineffective draft rigging.

The question of the amount of repairs occasioned by the draft gear is difficult to determine. F. F. Gaines, superintendent motive power of the Central of Georgia, in his article on "The Growing Cost of Freight Car Repairs" in the American Engineer shows that all items connected with coupler and draft gear covered 38.91 per cent of the total repairs on the cars repaired by the Central of Georgia during six months. M. K. Barnum is authority for the statement that the damage to the draft gear alone is about 18 per cent. Figures have been given as high as 54 per cent to 68 per cent. One large system found the cost of draft gear repairs was 53 per cent of the total.

You will notice Mr. Gaines does not include any damages to center or end sills as a part of his draft gear troubles. Therefore, I consider his figure as being too low. Suppose 45 per cent was the proper figure; just look over your repair bills for last year, and see what this means in dollars and cents.

#### REQUISITES OF A FRICTION DRAFT GEAR

What are the requisites of a good friction draft gear? It should have a small number of parts. Some friction gears have 2; some 34. It should be possible to readily inspect the gears. Closed gears often run with broken parts, which cannot be examined unless the gear is taken off the car at a considerable expense.

A gear should weigh as little as possible. Some friction gears weigh 110 lb. per car; many weigh 300 to 350 lb., and some 700 or 800 lb. per car. A draft gear with very high capacity and an initial high capacity is of no value. C. A. Seley, before the Western Railroad Club, stated: "The thing that wears out the cars is the multiplicity of small shocks—thousands of them—and a gear to take up these is far more desirable than one to take up maximum shocks that occur once a day, once a week, or whenever you please."

When a train is running under full headway there are small shocks which should be provided for. The drawbar pull may run from 8,000 to 14,000 lb., and you will notice little shocks occurring once or twice a second, working the platforms of the car forward and backward. This motion should be taken up on a spring gear. It is a comparatively delicate shock, and will wear out a friction gear rapidly in case the gear is so designed that it is essential for the friction parts to move in order to take care of this vibration. A primary free spring motion is essential in order to take care of the light shocks and save the wear on the friction parts, which should only be brought into play for the heavier loads.

The friction gears should have a capacity of 160,000 lb. when new, and at the end of a few weeks should carry more than that, as by that time the parts will have a chance to wear to a proper bearing surface. At the end of two or three years they should have their original capacity, at least. Some gears wear themselves out in two or three years.

A duration test may be made by any railroad having a good sized bulldozer. The friction gear is put in the bulldozer, and opened and closed a number of times to determine how many



closures it will make before wearing out. The gear is weighed before being put in the machine, and is then opened and closed, say 500 times; then reweighed and examined, and then put in again, and the test run to the number of strokes considered necessary. It is well to put a large timber back of the gear to protect the bulldozer from damage at the time the gear goes solid. It is necessary to stop the test every little while, so that the gear may be allowed to cool and not become too hot. Following are the results for several gears tested in this way by Prof. Gebhardt, of Armour Institute:

Gear	No. of movements	Action of gear	Condition of gear	Loss of weight at end of test	Remarks
A	2011	Smooth	Good	2 lb. 1 3/4 oz.	1 1/2 in. lost motion.
B	1750	Very irregular	Broke, test stopped	1 lb. 6 3/8 oz.	During test several parts were removed because of breaking.
C	982	Very irregular	Broke, test stopped	2 lb. 3 7/8 oz.	1 3/8 in. lost motion.
D	After 400 to 500 movements of service.			the gear was out	Friction parts worn out before 500 movements.
E	2500	Capacity increased		0 lb. 3 2/10 oz.	No set.

Partial results of an endurance test of the Harvey friction spring gear are shown in the diagram.

A friction gear should not stick. If it does there is no shock absorber for the next shock, and the gear will run with slack.

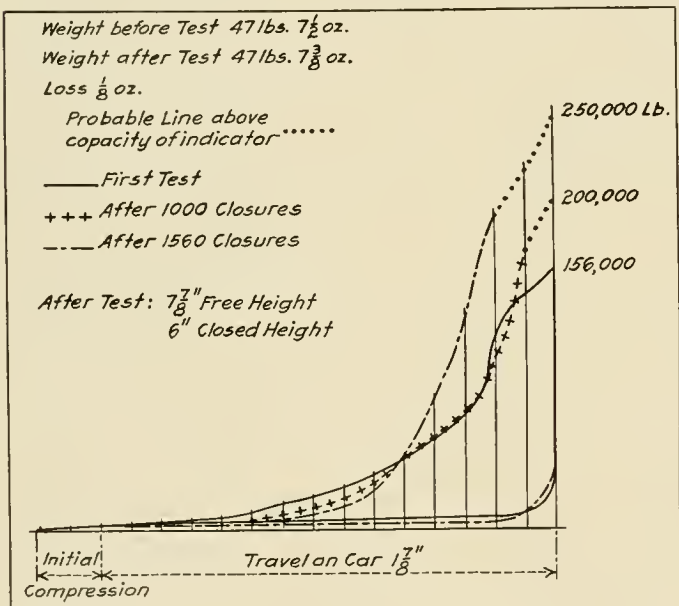

Endurance Test of Harvey 8 in. by 8 in. Friction Spring Draft Gear

and if it remains in that condition the entire rigging may be destroyed at the next heavy blow.

The area of friction should be large. It has been found in duration tests that gears with small friction areas wear out more rapidly than those with large friction areas. Some gears have as low as 64 sq. in. of friction area, while some have over 120 sq in.

I know of a road which has had 40,000 gears with no expense for maintenance in three years. Another road has over 20,000 gears, with an expense of maintenance of .021 of one cent per gear per annum.

I have seen reports of roads where the cost for maintaining another friction gear was 13 cents per gear; another 20 cents per gear for a period of nine years and three months on 5,800 cars. The cost in this case does not take into account the cost of couplers, center sills, end sills, etc., etc., but these figures alone are worthy of considerable investigation.

It is essential that draft gears should have a low release, running from 12,000 to 20,000 lb. A high release means damage to the cars. I know of a train of 74 steel cars, where three couplers were broken, due to recoil, after the train had come to rest and the air brakes were released.

One road thought it was doing a fine thing when it used a gear with a closing capacity of 500,000 or 600,000 lb. It was said that the horn of the coupler showed practically no marks on the end sills; after trying many thousands of these gears, it is now discarding them as the gear had a very high recoil—too great for the car to stand and the draft gears went to pieces.

It is rather difficult to determine just how one is to find out what the best gear is for the purpose from laboratory tests, as they are unable to reproduce the service conditions.

Many roads pass on the value of the draft gear by the static test card, thinking that the gear with the largest area of card will show the best results in service. This theory one would naturally think would be correct, but it is not. My explanation is simply this, that the gears do not develop the same characteristics when struck a quick pile driver blow, or a blow in train, as they do on the static testing machine.

In comparing a series of drop tests with those on a static testing machine it was found that the gear with the smallest area of card was the greatest shock absorber, while the gear with the largest static card gave the poorest results. There is no laboratory test that can give you the information of service tests. You may find a gear that will stand up under certain laboratory tests, and will prove absolutely inadequate in service. There is no test like train service and no drop test like the test of dropping trains on trains.

DRAFT GEAR RESULTS

The Railway Age Gazette, in its request for an article on draft gears, stated: "The judges will base their decision on facts and evidence presented to show which types of draft gear are giving the best results." It evidently meant the best results in service and not in the laboratory tests.

Let us assume that the average cost of repairs on a freight car is \$60 per year, and that 45 per cent of the repairs is chargeable to draft gears. The draft gear cost for maintenance would then be \$27 per year. Mr. Fritts showed that friction gears will save 64 per cent of the draft gear troubles. In other words, by using a good friction gear you could save 64 per cent of this \$27, or \$17.28. How long will it take to pay for a friction draft gear at this rate?

SOME NOTES ON CHILLED CAST IRON WHEELS\*

BY E. B. TILT  
Engineer of Tests, Canadian Pacific

In the following notes on the use of chilled cast iron in car wheels all questions of design, including flange and plate thickness, as well as weight, have been disregarded, and only the metallurgical problems of how to make white iron harder or more resistant to wear, and how to make the combination of white and gray iron in the flange stronger and tougher, have been considered.

Fig. 1 shows a new 675 lb. M. C. B. 1909 design wheel, in accordance with the specification with reference to chill. The M. C. B. specifications prescribe a method of selecting wheels for test, which are drop-tested for strength and thermal-tested (1 1/2-in. ring of fluid iron poured around the tread) to show their capacity to resist the heating action of the brakes.

Fig. 2 shows a flange which has been knocked off with a hammer to show the direction of break. This is one of the greatest sources of danger in the cast-iron wheel, though a seam at the throat very often precedes failure. Fig. 3 shows a typical failure due to over-heating by the brakes.

"Brake burns" and "shell outs" are minor defects, but to increase the service of the wheels they should generally be a minimum. It is not known whether metal which shells out or brake-burns easily is dirty or has more impurities than a metal

\*Abstract of a paper presented before the American Society for Testing Materials, at the seventeenth annual meeting, June 30 to July 3, 1914.

which does not. It is hoped to get some connection between this trouble and the different coefficients of expansion of the compounds forming the metal.

There is at present some disagreement among authorities on chilled cast iron as to the best mixtures. Some contend that charcoal iron of chilling quality is necessary; others that steel



Fig. 1—Tread Section of a 1909 M. C. B. 675 Lb. Wheel

scrap and ferro-manganese serve the same purpose. A representative mixture of each is approximately as follows:

CHARCOAL IRON MIXTURE

Charcoal pig iron.....	70 per cent
Scrap wheels .....	30 per cent

STEEL SCRAP MIXTURE

Coke pig iron.....	45 per cent
Old wheels .....	45 per cent
Malleable scrap .....	5 per cent
Steel .....	5 per cent



Fig. 2—Flange Broken with Hammer, Showing Direction of Fracture

Wheels made of each mixture meet the specifications. In the author's opinion service results depend on the final composition, and care of manufacture and inspection. Direct comparisons are difficult to make on account of different methods of keeping

records; and comparisons of wheels made now of coke iron with wheels made years ago of charcoal iron are difficult on account of changes in the service conditions. A representative analysis of present-day wheel iron, using coke pig iron and steel, is as follows:

Total carbon .....	3.60 per cent
Silicon .....	0.60 per cent
Manganese .....	0.50 per cent
Phosphorus .....	0.30 per cent
Sulphur .....	0.12 per cent
Iron .....	remainder

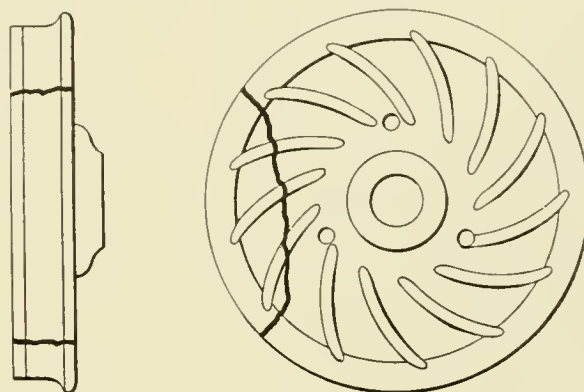

Fig. 3—Typical Failure Due to Overheating by Brakes

The best proportions of the metalloids and their compounds, and the compounds of silicon and manganese are not definitely settled. Nickel, chromium, vanadium, titanium, and other metals have been used with results not always exactly determined. It is the author's opinion, to be confirmed by further experiment, that the amount of total carbon should be low, say about 3.40 to 3.60 per cent, rather than about 4 per cent, as with many white irons. The silicon content will generally be somewhat higher than the manganese, but both in the neighborhood of 0.60 per cent. Good wheels are made with sulphur as high as 0.17 per cent and phosphorus 0.50 per cent.

An examination of Fig. 1 shows the flange to be white iron in part, and Fig. 2 shows the broken flange continued down through the gray iron, which is the usual direction of breaking. Fig. 4 shows stress-deformation curves for gray irons from the

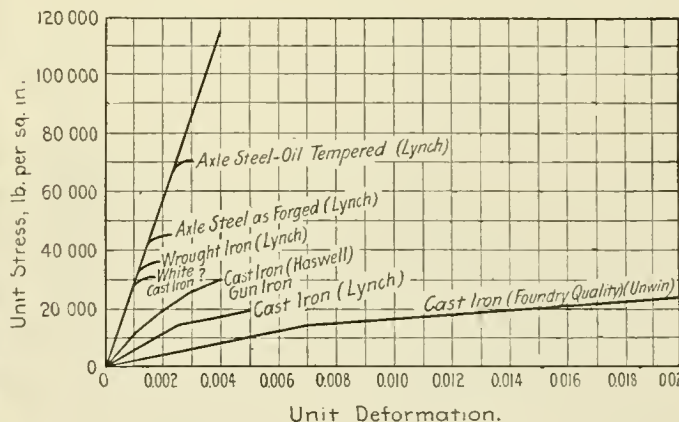

Fig. 4—Stress-Deformation Curves for the Common Steels and Cast Iron

sources noted, and for comparison the curve for the common steels is included. A curve for white iron is shown where it is thought it might be found. It is evident that the flange strength is dependent upon two substances. The first is the white iron which carries almost all the load until rupture takes place in it, when the gray-iron back takes the load; and it is evident that if both could be of the same elastic ratio an improvement would be made. A possible solution is to have as much white iron as can possibly be allowed, and also to have the gray iron as



hard as is possible without its being too brittle in the plates. In order to see whether the strength of white iron varied appreciably in our regular practice, it was decided to test chilled circular rolls, 2 in. in diameter, and partly chilled rectangular bars 1½ by 2½ in., similar in structure to the flange of a wheel. Fig. 5 shows the ends of two rolls, also a regular wheel

TABLE I.—HEIGHT OF DROP TO BREAK BARS OF WIDELY DIFFERENT MIXTURES

Quality of Iron	Silicon, per cent	Combined Carbon, per cent (estimated)	How Cast	Chill	Height of Drop to Break, in.
Wheel iron.....	0.68	3.50	Chiller	Completely	15
Wheel iron.....	0.68	1.00	Green sand	None	27
Cylinder .....	1.27	....	Chiller	Around edge	14
Cylinder .....	1.27	0.90	Green sand	None	21
Machinery .....	1.60	....	Chiller	Mottled throughout	10
Machinery .....	1.60	0.60	Green sand	None	18

foundry chill block taken to show the amount of chill at each tap, and of one of the partially chilled test bars. These bars were drop-tested on 10 in. supports with a tup of 423 lb., caught on the rebound. The drop was started at 8 in. and increased 1 in. at a time until the bar failed. The difference in height of the drop to break bars of widely different mixtures, in chills and in green sand, is given in Table I.

An interesting point is that when the wheel-iron bars are annealed in the pits with the wheels (a period of 4 days), the average height of drop decreases from 15 to 12 in. This would

TABLE II.—DROP TESTS ON HALF-CHILLED BARS

	Depth of Chill, in.	Height of Drop to Break, in.
Maximum.....	{ 1.30	18
	{ 0.95	18
Minimum.....	{ 1.05	12
	{ 0.60	12
Average.....	{ 1.20	13.5
	{ 0.75	14

suggest that unannealed flanges are the strongest. When the unannealed bars are heated to 500 deg. F. and tested at that temperature, the average height of drop is increased from 15 to 20 in. This suggests less liability to strip flanges by blows under heavy brake service.

Records were kept for a number of months' operation of the

in tension, are shown in Table 2. The difference in the amount of chilled iron is at or near the neutral axis and has very small effect on the strength.

In order to get a direct measure of the strength of the flange we have been drop-testing the flange of the wheels on a small

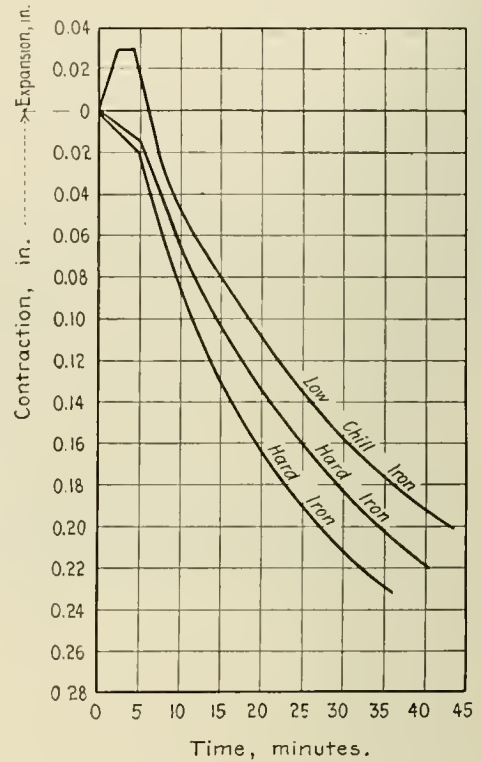

Fig. 6—Shrinkage Curves for 1 In. Square Bar, 12 In. Long, Wheel Iron, Cast in Sand

drop-testing machine, with a 25 lb. tup falling on a striking block 2 in. wide with a face having the contour of the throat of the flange. After some experimenting 6 ft. was taken as the height from which to drop the weight, and we have found that for the same mixture the number of blows to break off the

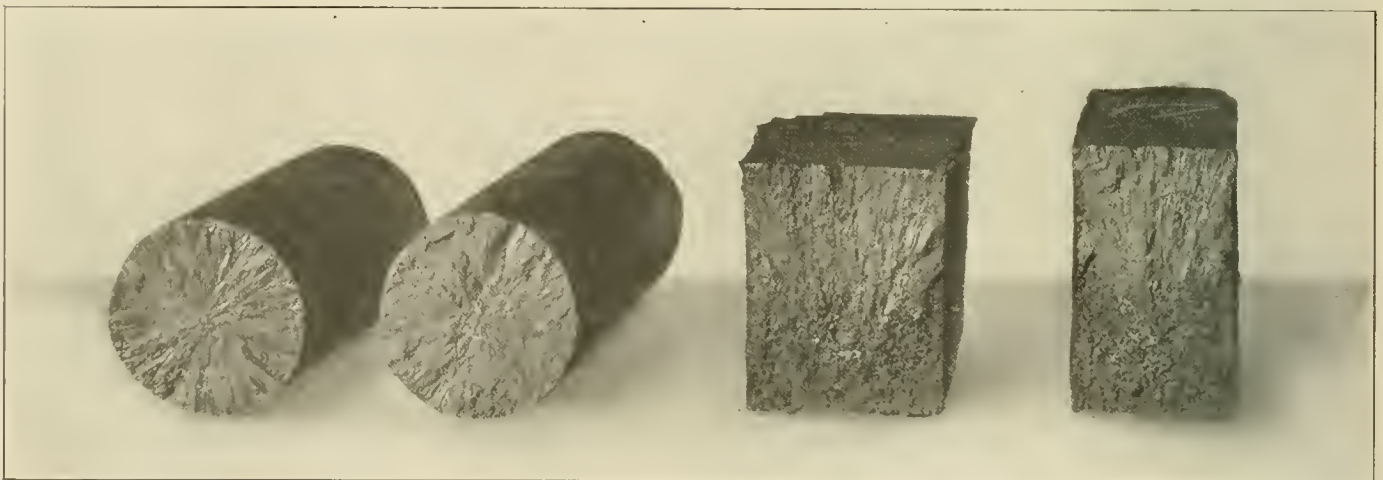

Fig. 5—(a) Ends of Two Chilled Rolls; (b) End of Chill Block; (c) End of Partly Chilled Rectangular Block

wheel foundry, by plotting the results of the drop tests, a consideration of which seems to show that the greatest strength of the white iron is accompanied by the greatest hardness, though the variation due to composition, or any cause other than flaws in the test specimens, is small. Representative drop tests on the half-chilled 1½ in. by 2½ in. bars with the white iron down or

flange is inversely as the chill. This means that a soft wheel has the strongest flange. In service we have more stripped flanges in soft wheels than in hard, but this is due to the development of cracks in the throat of the flange. This suggests that the design of the wheel and care in securing enough chill are more important than differences in quality of the iron.

A possible improvement in wheel iron, to avoid trouble with broken wheels, is the making of an iron with a low coefficient of expansion under brake action. Heavy braking results in heating the tread, with consequent expansion and pulling apart of the plates. Thermal tests on a large number of wheels show an increase in diameter of about 1/16 in. after the iron ring has been on two minutes, failure taking place after an increase of 3/64 in. or more, depending on how much white iron or combined carbon is in the plates of the wheel. The harder the wheel the more readily it is broken in the thermal test. Part cooling curves for wheel iron are shown in Fig. 6. Note the expansion in cooling of one wheel mixture which was soft. A wheel poured from this would have the flange and tread chilled and set at once and the expansion due to the gray iron behind might cause some checking of the chilled iron, which would show as a defect developed later in service. So too it has been thought by some that brake heating produces circumferential throat seams, due to expansion of the tread which is resisted by the flange. If low-expansion iron is a possibility this tendency would be lessened.

Experiments have been in progress for some time. The fuels used have been high and low-sulphur cokes and anthracite coal; and the mixtures have varied from all-scrap wheels to charcoal iron with malleable and steel scrap. Six test wheels have been cast from each test heat, of which two each have been thermal, drop and flange tested. Up to the present there has been no improvement on our standard mixture containing scrap steel. Our test work is to continue and it is our expectation that we will find mixtures and perhaps methods to improve the cast iron wheel.

#### DISCUSSION

Great emphasis was placed on the desirability of a perfectly even chill in the tread of a car wheel, and attention was called to variations in depth of 1/8 in. to 1/4 in. A mechanically operated chill was described by which this end could be obtained. It consists of a number of segmental blocks which are moved in towards the tread as it contracts in cooling.

One speaker took exception to the practice of substituting coke for charcoal iron and maintained that it is impossible to obtain the same evenness and depth of the chill with coke that could be obtained with charcoal. It was maintained that the reason for this superiority lay in the fact that charcoal iron contained more oxygen than coke iron and had the property of retaining it through the cupola; and that this gave an added strength to the metal that could be obtained in no other way. It was the general opinion, however, that it is chemical composition that is the controlling factor in the making of a car wheel, melting and pouring being the same, and that it is a matter of indifference as to whether the iron be made in a charcoal furnace or not.

EATING IN THE FOUNDRY.—Both the states of New York and Illinois absolutely prohibit eating in the foundry. New York requires that suitable quarters be maintained to enable the workers to take their meals elsewhere in the establishment. Illinois specifies lunch rooms wherever practicable. Eating amid the dust and fumes of the foundry is plainly objectionable, as is the handling of chewing tobacco without washing the hands. The practice of allowing a period of 10 or 15 minutes in the middle of the morning for the eating of food brought into the foundry, which is a relic of days when the hours of labor were much longer, and is still common, especially in some parts of the Middle West, is reprehensible, as it does not allow time enough for the workers to go to and from the lunch room, and means that food is eaten amid dust and with dirty hands. Such a recess is hardly necessary with modern hours of labor, but, if given, should be long enough to allow washing and the use of the lunch room.—*From Brass Furnace Practice*, by H. W. Gillett.

## INTERCHANGE INSPECTORS AND CAR FOREMEN'S CONVENTION

The fourteenth annual convention of the Chief Interchange Car Inspectors and Car Foremen's Association was held in Hotel Sinton, Cincinnati, Ohio, August 25-27, President F. C. Schultz, chief interchange inspector, Chicago, presiding. The convention was opened with a prayer by Rev. Henry C. Martin, of St. Luke's Methodist Church, and the association was welcomed to the city by Mayor Spiegel. The secretary-treasurer reported a cash balance of \$31.19, and a membership of 422.

#### PRESIDENT'S ADDRESS

I want to call at this time the particular attention of the association to a number of changes in the M. C. B. Rules of Interchange, which I think are important and should result in revolutionizing the handling of car equipment in this country. Rule No. 1 provides that each railway company must give to foreign equipment the same attention in the way of repairs that it gives to its own cars, and in discussing this rule during our meeting here, I hope that the members will place such interpretation upon this rule as will result in carrying out the intention of the framers of this rule, which, as I understand it, means that foreign equipment away from home will hereafter not be neglected. I hope further that the interpretation placed upon this rule at this meeting will result in a condition that will prevent cars not fit for service from being interchanged after October 1. It is up to those who have charge of repairs to see that this matter is put squarely up to their car foremen to see that this rule is carried out. The benefits to be gained from carrying out the wishes of the framers of this rule are that the investment of the car equipment in this country will be materially reduced, for the reason that we have heretofore been obliged to carry a maximum amount of equipment, in order to take the place of that large percentage which is continually in bad order, and therefore unfit for service. From observations I have personally made I predict that, if the equipment is kept in shape as the rule provides, the number of cars necessary to carry on the commerce of this country can be reduced at least 5 per cent, and the saving in the cost of this equipment is apparent. I also wish to call attention to the footnote under M. C. B. Rules 37 to 42, which permits us to inspect a combination of worn out and decayed parts, and authorize the handling line to make the repairs and bill the car owner. This rule is a step in advance, but in carrying it out I hope that those in charge of the car department will administer this rule in fairness, and not saddle on the car owner the cost of damage which is due to unfair usage instead of wear and tear as this rule intends. The operation of this rule will work out a hardship on car owners unless it is carried out honestly. A very decided step in advance has also been made in the change in M. C. B. Rule 120 and the elimination of Rule 121.

When these rules go into effect, I clearly see the necessity of a practical man to pass upon the bills rendered under the footnote under Rules 37 to 42, and to make a decision as to the advisability of requesting the handling line to repair or destroy the equipment reported under Rule 120. I also see the necessity of the railroad companies providing at large terminals sufficient facilities to take care of the foreign equipment that will necessarily be held up at large interchange points as the result of the enforcement of these rules. This can best be accomplished by the co-operation of the interested lines who should establish joint car shops in localities where the equipment necessarily will accumulate, and for the further reason that it is far more economical to carry a stock of foreign material at one or two locations in a large terminal than require each railroad company to stock up with that material. Also the car shop men employed by the railroads can do more efficient work on their



own cars than they can when they are being switched on a miscellaneous lot of equipment. This will result in increased output, and also better work on foreign cars, as the men employed in the joint shops will become more familiar with this equipment. In addition to this cars destroyed under Rule 120 will provide a lot of good material that can be applied to cars that are to be repaired and not destroyed. Such facilities should in my opinion be located in territories where there are a large number of cars unloaded and an equal demand for empty cars for loading. This practice will eliminate the necessity of delivering empty cars for loading in this territory, resulting in a large saving in per diem, as well as in switching charges.

I also wish to call particular attention to the necessity of our members thoroughly familiarizing themselves with the Safety Appliance Laws, and to see that cars are not offered in interchange with defective safety appliances, and that when equipment is found with these defects, it is seen that it is promptly repaired.

I want to remind the members of the fact that we are here especially for the purpose of discussing and arriving at an understanding of the rules that have been adopted by the Master Car Builders' Association. Attention is also called to the growing feeling that the services of car inspectors can be utilized other than for the purpose of car inspection, and that they can properly record and handle seal records, and such other data that is necessary to make complete interchange reports in addition to the mechanical records now taken by them. This practice has now gone beyond the experimental stage, and is being encouraged by the executive officers of the railroads. All our members should assist in every way possible so that this practice can be extended.

#### DISCUSSION OF THE M. C. B. RULES OF INTERCHANGE

*Rule 1*—The members seem to fully understand that this rule requires as complete and efficient repairs to foreign equipment as would be given to equipment of their own company, and that no distinction is to be made whatever. It was not taken, however, to mean that each road was to maintain the periodic inspections and attentions that are standard on some foreign roads, such as the repacking of journal boxes, etc. The car foremen were cautioned that in order to fully comply with this rule they must get their shops in condition to handle this work. It was believed that the strict adherence to this rule would keep all cars in much better shape and eliminate a great deal of the damaged empty car mileage all over the country, as well as materially decrease the car shortage. In connection with this rule one member spoke of a complaint by a mechanical officer that the repair bills received from foreign lines greatly exceeded those chargeable to foreign lines. He was told that this was caused by his road not keeping its equipment in proper shape, and that as many repairs were not made to the foreign equipment as might have been made provided his road had the proper shop facilities.

*Rule 2*—Trouble has been experienced in the matter of carding old defects that in the mind of the inspector at the previous interchange point was not cardable, thus making the delivering line responsible, where, as a matter of fact, they received the car in its present condition. In a case like this it was believed that the first inspector should make note of such defects in order to protect the line to which he delivers the car. Local arrangements are sometimes made where loaded cars with cardable defects are allowed to proceed to their destination for unloading, provided the distance is not too great, the delivery line agreeing to take the car back. This is done to eliminate the cost of transferring the load, and where the car is safe to run to its destination this practice is believed justifiable. However, when the new rules go into effect, it is believed that the inspection should be tightened down and the above practice eliminated. In the matter of refuse in cars, the delivering line is held responsible, and the cars are considered as bad order cars.

*Rule 3*—The question was raised as to whether it was permissible to apply doors and fastenings to empty cars previously loaded with rough freight, and charge the car owner for this work, provided the car was to be reloaded in a service that required these attachments even though the car was marked "For rough freight only," and contained a notation that no doors or fastenings were required. This is to be referred to the M. C. B. Arbitration Committee.

*Rule 4*—Trouble has been experienced in the case of wrecked cars where all of the defects were not carded at the first interchange point on account of the inability of the inspector to accurately determine the full extent of the damage. Technically this makes the line delivering the car home responsible for the additional defects found at the joint inspection with the owner and the inspector, although it is known that defects were caused by the wreck. In cases such as these it was believed that if the first inspector was informed immediately, the original defect card could and should be corrected. Most of the trouble has been experienced where this was not done until some considerable time after the car was received home. One chief interchange inspector allows the car to proceed on "notation," and does not attempt to make out a defect card until the full extent of the damage has been ascertained. Some of the members desired a definite rule covering these conditions.

*Rule 20*—It was believed proper and permissible to bill car owners for placing shims in center bearings and side bearings on pedestal trucks in order to raise the coupler to its proper height. In the case of Fox trucks the shimming of the springs was deemed advisable and good practice.

*Rule 42*—The interpretation given to the foot note under this rule is that in case of damage done to new or substantial parts on account of decayed or unduly worn parts the owner will be responsible up to a combination of defects of new or substantial parts. In the latter case the delivering line will be charged for the combination and the owner for the decayed or worn parts. The chief interchange inspector must use his judgment in determining whether defects come under this rule or Rule 120, as no definite line can be drawn between these two rules on account of the varying nature of the damages or defects.

*Rule 115*—A question was raised as to just what "individual ownership" meant, and the consensus of opinion seemed to be that private car lines were intended. It was decided that individual ownership meant private car lines, the reason being given that these lines find satisfactory use for trucks of 50,000 lb. capacity.

*Rule 120*—While this rule relieves the necessity for obtaining home route cards, and leaves only two options for the car owners to choose, it does not give a definite time in which the owner of the car is to give authority for its destruction or rebuilding. This has previously caused a great deal of trouble under the old rules, and the roads that would try to live up to the rules strictly found their repair tracks overloaded, and oftentimes waited a year or 18 months for the necessary authority to dispose of the car. The members believed that a time limit was absolutely necessary, and are to petition the M. C. B. Association to request the railroads to give joint inspection reports on this rule their immediate attention, or to make some arrangement whereby the road holding the car can act on the joint inspection after a certain time has expired. The Lake Shore makes a practice of investigating load transfers that are charged to them with a view of eliminating the trouble at the source. It was believed that if this was more generally done much better results could be obtained. Honesty is the basis of the successful operation of this rule, and all inspectors must clearly keep this in mind.

The following officers were elected: President, F. H. Hanson, assistant master car builder, Lake Shore & Michigan Southern; vice-president, A. Kipp, chief car inspector, New York, Ontario & Western; secretary-treasurer, Stephen Skidmore, Big Four.

# SHOP PRACTICE

## TURNING CRANK PINS IN A QUARTERING MACHINE

BY R. F. CALVERT

The drawing shows an attachment used at the Horton, Kan., shops of the Chicago, Rock Island & Pacific for turning crank pins in a quartering machine. This shop has no special machine for doing this class of work, nor has it the attachment for use on the wheel lathe. Therefore this method of turning pins in the quartering machine was devised and has been in use for several years.

The attachment consists of but two pieces aside from the tool. The piece *A* is a wrought iron angle or casting. One end is

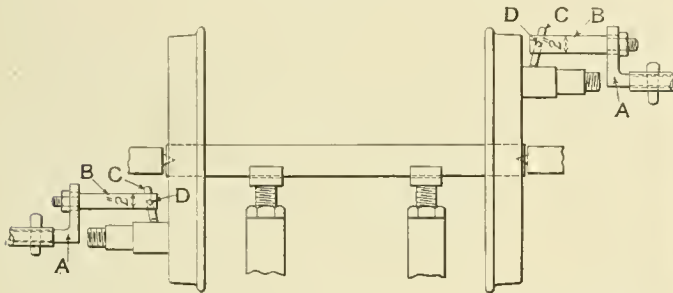

Attachment for Turning Crank Pins in a Quartering Machine

made to fit the socket in the tool post, in which it is held tightly by a taper key. The other end, which is about 3 in. x 1 1/4 in., is slotted about 2 in. for a 1 1/4 in. rod. This slot allows adjustment of the tool post *C* for different size pins. Tool post *C* is a round rolled steel post 2 in. in diameter by 10 in. long, turned down to 1 1/4 in. for about 3 in. on one end, and threaded for 2 in. from the end. The other end is bored or broached to take the tool, which is secured by a set screw. This device will be found useful in shops not equipped with the special devices for doing this class of work and also in the more up-to-date shops where the other machines are rushed.

## DIES FOR FORGING RUNNING BOARD SADDLES

BY J. LEE

The dies illustrated are used on a No. 5 Ajax bulldozer for the manufacture of pressed steel running board saddles for box car roofs. The type of saddle is shown in detail in Figs. 1

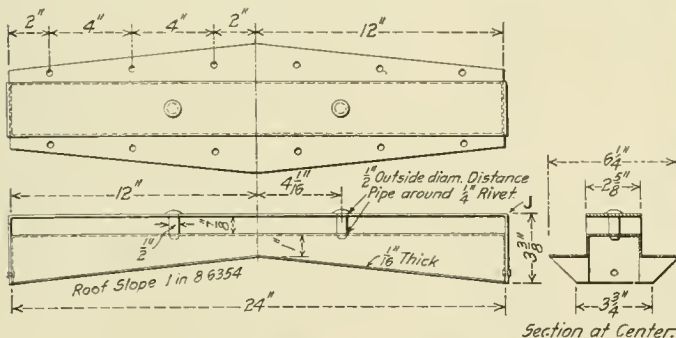

Fig. 1—Pressed Steel Running Board Saddle

and 2. The arrangement of the dies is shown in Figs. 3 and 4, *B* and *C* being the moving and stationary dies respectively,

Blanks are first cut in the form shown in Fig. 2, the holes and slots all being punched in one operation by means of a die on another bulldozer.

In operating the dies the blank is placed in the machine in front of, and against the stripper *D* on die *C*, with the end against gage *A*. The moving die then makes the stroke

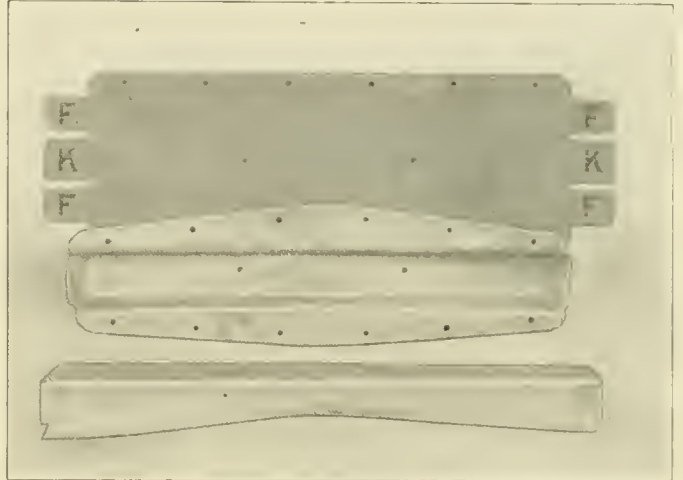

Fig. 2—Completed Saddle, and Blank from which it is Forged

and forms the saddle around die *C*. The tools *HH*, one of which is removed to show the interior of die *B*, form the ends *K*. A feature of the die *B* is the clamping and stripping device, consisting of four projecting pins *E*, which are held out by heavy springs; this works in conjunction with the stripper on die *C*, rigidly clamping the stock during the stroke of the machine. When the moving die has moved forward a certain portion of

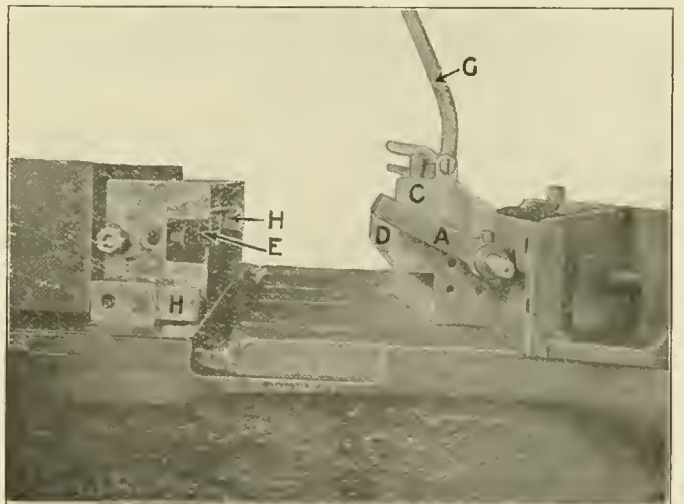

Fig. 3—Dies in Place on the Bulldozer, Showing Stripper *D* Locked in Compressed Position

the stroke, these pins are forced in by the stock, which is held securely against the stripper *D*, and as the stroke is completed, both the stripper and pins are forced flush with the die faces. As the moving die returns to rest, the pins resume their former extended position ready for the next stroke. These pins act as strippers, ensuring that the form is left on the stationary die. The stripper *D*, which is spring operated, does not resume its



extended position, being automatically locked flush with the die face, as shown in Fig. 3, by two pins which are attached to the handle G. Before removing the saddle from the machine, ends FF are bent over by hand. This completes the saddle and the

is also moved along the spindle to the required length. The tools *HH* on the moving die have an offset, and are reversed to ac-

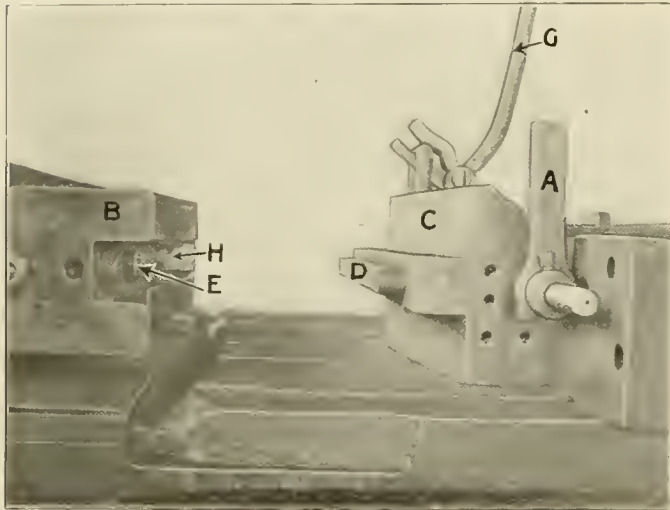

Fig. 4—Stripper D in Release Position

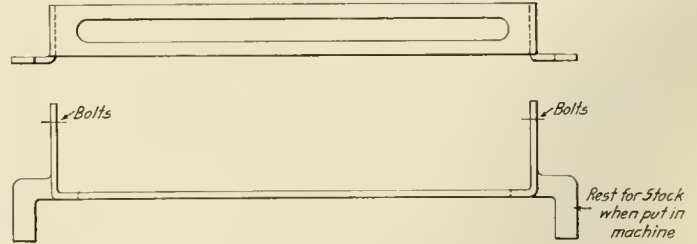

Fig. 5—Extension Used on Stationary Die When Forging Saddle Straps

commodate the thicker stock in the strap. With these changes the dies are ready for use in bending the straps.

### PIPE BENDING MACHINE

BY PAUL R. DUFFEY

A pipe bending machine, the construction of which is shown in the drawing, is a very serviceable pneumatic device for use on the car and shop tracks. The double bending die permits the bending of pipe to either a large or small radius. Hinged blocks are attached to the channel side frames, and when using the upper die these serve to support the pipe in line with the die. When not in use they may be turned down inside of the frames, thus leaving the top of the frames in line for the lower die. The 12 in. brake cylinder which operates the dies holds the pipe

stripper is then released by raising handle G, when it resumes the position shown in Fig. 4, and removes the saddle from the die.

The strap shown at J in Fig. 1 is also made with the same dies. This requires the application of a packing strip, Fig. 5,

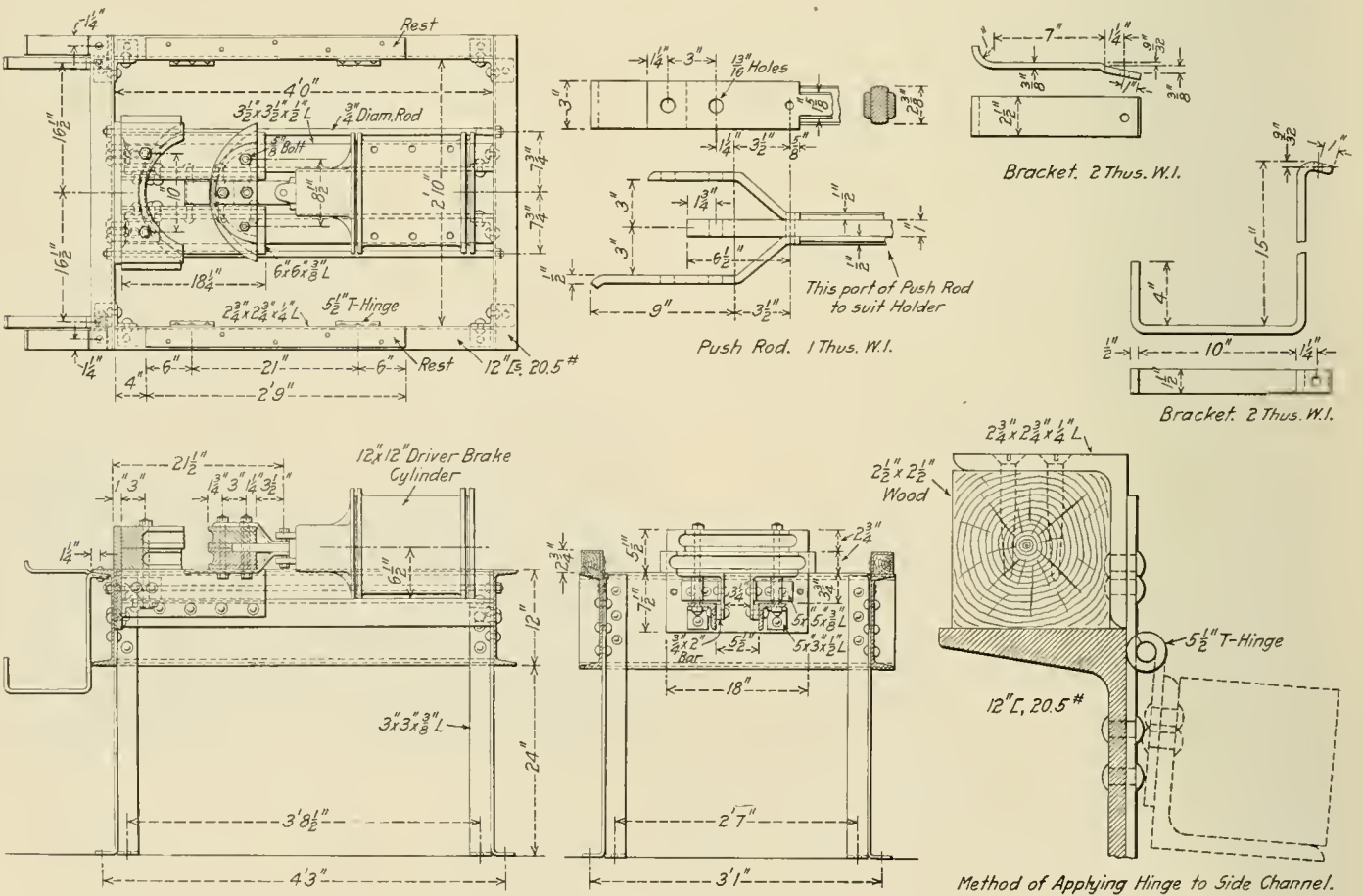

Pipe Bending Machine for Shop or Car Repair Tracks

which is bolted around the projecting portion of the stationary die to make up the difference in depth. This has an extended slot in its face through which the stripper works. The gage A

rigidly in place, with no chance for slipping. With proper manipulation this machine very much lessens the chance of crushing pipe in making short bends.

# ORGANIZATION OF ENGINE HOUSE FORCES

Prize Article of Recent Competition Also Touches On  
Equipment for 36-Stall House and Machine Shop

BY R. G. GILBRIDE  
Locomotive Foreman, Grand Trunk Pacific, Graham, Ont.

The matter of organization of the average engine house is left largely to the foreman, and depends to a large extent on general conditions and the volume of traffic handled. On the railways on which I have been employed the stores department has been a separate department and under the control of a general store-

at the shop, should place his engine on the coaling track, and after making his usual inspection, the engine should be taken charge of by the hostler. The hostler's first duty should be to examine the crown sheet and see that the enginemen do not remove any tools belonging to the engine equipment. After the engine is coaled, sanded, and moved over the ash and inspection pits, it is placed in the engine house. During this time the engineer books in on the rest or register book provided for that purpose, and shown in Fig. 2, and reports the necessary work on the work book. This work book can be made with carbon sheets attached in triplicate if desired, to save copying the work reports, but I have obtained the best results with the work book in which the men make the one report, which is copied by either the leading machinist or a man assigned to the work. The engine crew should be instructed to report the work in the following order:

- (1) All boiler work, including grate gear, ashpan, and front end work;
- (2) Air brake work;
- (3) Machinist's work and minor repairs to cab, pilot, etc.

By this time the shop inspector will have completed his inspection and made his report in the shop inspection book, which should be inspected daily by the foreman, and where engineers have failed to make the proper inspection, the matter should be brought to their attention. The locomotive should be inspected by the boilermaker immediately after it has arrived in the shop, as to the condition of the grates, tubes, brick arch, ashpan and other fire prevention parts.

The work reports and engine inspector's report are then handed to the various workmen by the leading machinist, who should endeavor to specialize the various classes of mechanics as much as possible, and arrange for any machine shop work, especially if new parts are to be gotten out. When the work has been completed, the various workmen hand their work slip back to the leading machinist and go to the work book and sign for what repairs they have made; this is very important in the event of law suits when questions may arise as to what work has been done. The leading machinist then O. K.'s the machine work to the engine despatcher, and also O. K.'s the machine work on the call board, the boilermaker charge hand following the same routine. This can be handled through a shop telephone system. The hostler then notifies the lighter-up men to put a fire in the engine, but this should not be necessary if the men are at all interested in their work, as they will then anticipate the completion of the repairs, and be ready to put in the fire at

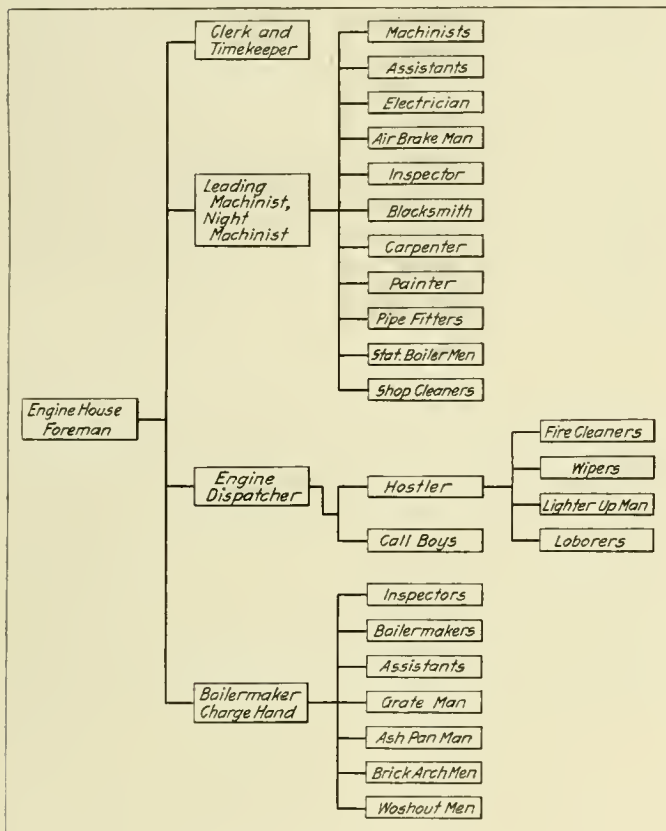

Fig. 1—Organization Chart

keeper, while the handling of coal was under the fuel department, the work being done by a contractor on the tonnage basis. This I consider the best practice, as it is more economical and relieves an already overcrowded foreman of work that properly should not belong to him.

The engine house organization shown on the accompanying

Enginemen's Register and Rest Book at _____				For (day) _____ (date) _____ 19__														
No. of Engine	No. of Train	ENGINEER	FIREMAN	WALKER FROM	DEPARTURE TIME			ARRIVAL TIME			ENGINEERS			FIREMEN			REMARKS	
					Date	A. M.	P. M.	Date	A. M.	P. M.	Hours on Road	Hours rest in previous 24 hours	Hours rest wanted	Hours on Road	Hours rest in previous 24 hours	Hours rest wanted		

Fig. 2—Register and Rest Book

chart, Fig. 1, is recommended. A coal chute of either the ramp type or the mechanical type, having two coaling tracks and with sand delivery to each track, should be used, the tracks leading directly to the inspection pit and ash pit tracks, which should be equipped with an air cinder hoist. The engineer, on arrival

once. However, it is not always advisable to have an engine lighted up at this time when the movement of traffic is not heavy. Care should be exercised in the use of the blower.

A washout board, having room for all of the engines assigned to the terminal, and dated from the first to the thirty-first of



the month, should be displayed in close proximity to the engine despatcher's desk. This board shows the date each engine is

acting under the foreman's instructions. The hostlers then cannot fail to know just what engines are due for washout, and should place them accordingly. The washout gang should be provided with a suitable washout cart, similar to the one shown in Fig. 3, capable of holding all of their tools and the washout hose, as there is a great loss of time from this class of labor moving their tools and hose from engine to engine. Spare washout plugs should be kept in this cart. The cart is mounted on hand car wheels, and has room for the men's clothes, and the lower shelf holds their long box wrenches and cleaning rods. On the reverse side a recess about 8 in. or 12 in. deep is made for the storing of the washout hose. The cart is easily made,

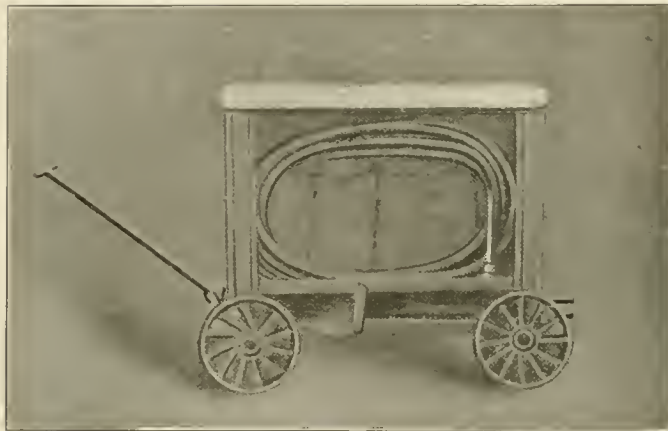

Fig. 3—Wagon for Washout Equipment

due for washout, or if on a mileage basis, the mileage made each trip. The board is kept up to date by the engine despatcher,



Fig. 4—Portable Test Pump

and with the use of old material costs about \$10. The system of washing out with hot water and blowing off through a blow off line is now practically general.

As soon as the washout is completed the inspector should go over the engine and make out the necessary cab cards and office records. Cab valves should be repacked, if necessary, at this time as well as the try cocks cleaned out and the gage glasses changed. One man should be assigned to this work, as it requires special tools, and he is also called upon to make records as to the condition of the gages, etc.

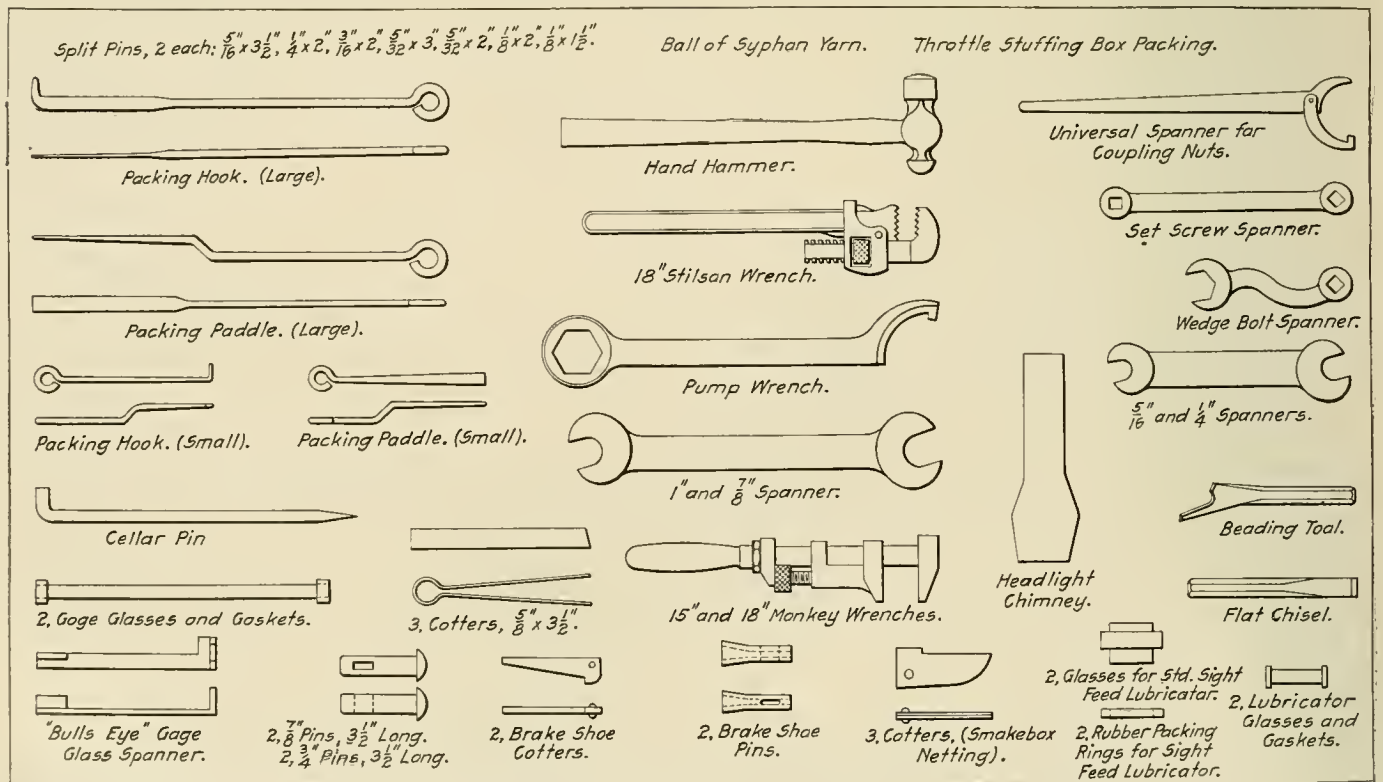

Fig. 5—Equipment for Locomotive Tool Boxes

The washout gang also make all hydrostatic tests which are required by the government. For this purpose a handy arrangement is the portable test pump shown in Fig. 4. It is also mounted on two old hand car wheels and was made from a discarded 8 in. air pump, the air cylinder being removed and a water cylinder of smaller diameter applied. By coupling to the

supplied before the expiration of 24 hours, the order is annulled. The practice of stating the cause of not supplying power prevents any discussion at a later date on this question, and each department has a record. The orders should be numbered commencing with one at midnight daily.

As soon as the engine is supplied the engine despatcher in-

APPEARANCE BOOK FOR THE SIGNATURE OF ENGINEERS										AND FIREMEN PREVIOUS TO TAKING OUT THEIR TRAINS								
Station _____										Day _____ 19__								
The numbers of all Regular Trains must be entered in proper order on the morning of each day, a red ink line must be drawn through the column to prevent										leaving no blank lines between. Should any Engineer or Fireman omit to attach his Signature, it being afterwards filled up, and the case must be at once reported.								
We, the undersigned, hereby certify that we have had sufficient rest, that we are in every way about to run, and we have read all new notices on the are carrying standard timetables which have										fit for duty, that we are properly acquainted with the section of the line over which we are been inspected in accordance with the Rules								
No. of Engine	TRAIN			ADVERTISED Departure of Train			ENGINEER'S Actual Time of Coming on Duty			FIREMAN'S Actual Time of Coming on Duty			SIGNATURE OF ENGINEER	SIGNATURE OF WITNESS TO ENGINEER	SIGNATURE OF FIREMAN	SIGNATURE OF WITNESS TO FIREMAN	REMARKS	
	No.	Class	Destination	h	m	sec	h	m	sec	h	m	sec						

Fig. 6—Appearance Book

water and air line, a quick and reliable test can be made; this is also convenient for making tests of steam and exhaust pipes.

For outgoing extra freight engines, or anything except regular engines, the transportation department should present regular printed order blanks in duplicate at least two hours before the

indicates this on the call board opposite the engine number and the names of the engine crew, showing the time ordered and the direction in which the train runs. The call boy is then despatched with a call book containing the same particulars as on the call

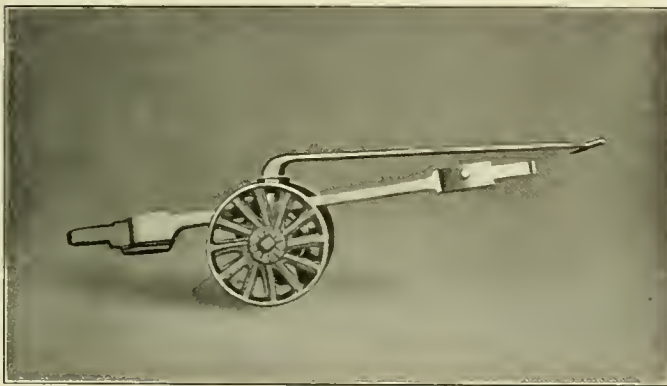

Fig. 7—Two-Wheel Truck for Carrying Rods

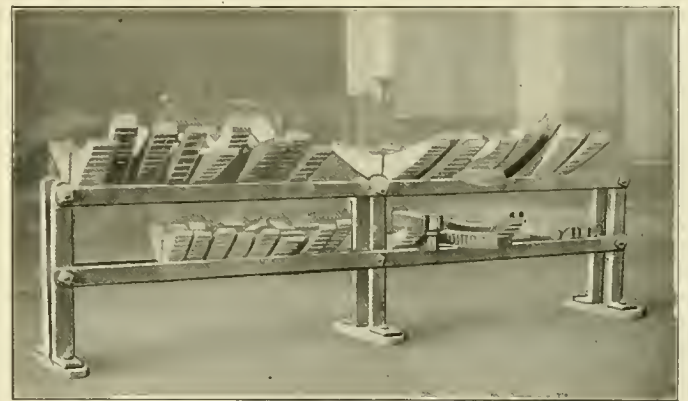

Fig. 9—Spring Rack

time the engine is required. The order blanks should be made with a perforated bottom stub, which the engine despatcher fills in and hands to the transportation department call boy when supplying power. The upper portion is filed by the engine despatcher, with particulars as to the engine number and the

board, which the engine crew is required to sign. The call book should be examined by the engine despatcher immediately on the boy's return. The call board used by the writer is about 5 ft. by 5 ft. 10 in., working in a sliding frame so that it can be raised and lowered, and contains the engine number, the train,

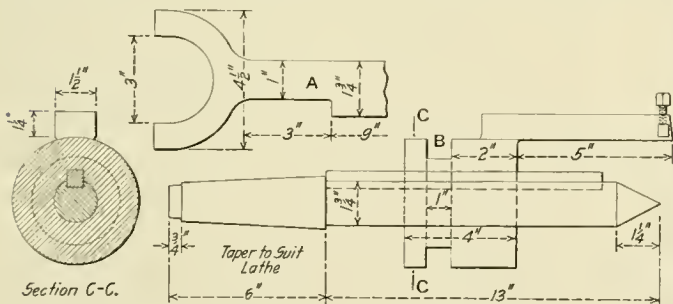

Fig. 8—Tool for Turning Tumbling Shafts

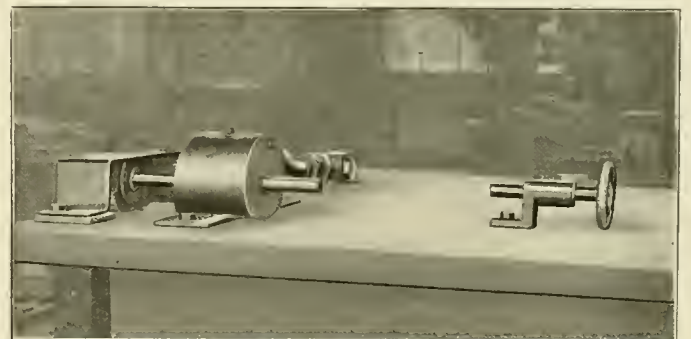

Fig. 10—Turbine Saw and Drill

time supplied entered on it. The transportation department call boy then pins the stub to the duplicate to be filed by that department. This duplicate is for use in the event of the motive power department being unable to furnish the power when required, as notations are then made on the back of the two orders as to the cause of delay. If the engine cannot be

the time ordered, the names of the crew and three columns for showing the machine work O. K., the boiler work O. K., and the engine fired O. K. At the bottom of the board room is provided for spare men, and men on sick leave or leave of absence.

It is the hostler's duty when taking the engine out to see that



it is properly equipped and also to test both injectors. Situated at the center of the turntable on one side, or in close proximity to the outgoing track, there should be an engineer's tool box rack, made of iron pipe, with shelves to suit the size of the terminal, on which the hostler or engineer will place the tool boxes when the engine is coming in, and remove them when going out. Fig. 5 shows the standard equipment recommended for the engineer's tool box.

The engine crew on arrival at the engine house must sign the appearance book, the form of which is shown in Fig. 6, their

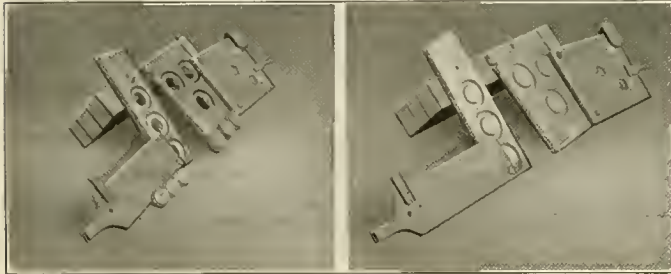

Fig. 11—Plates for Molding Metallic Packing

signatures being witnessed by the hostler or the engine despatcher. Either the hostler or the engine despatcher should also be required to note the time that the engine leaves the shop tracks, and whether there are any delays. This is very important as while, of course, the transportation department will never attempt to place any blame for delay on the motive power department, yet this information sometimes proves extremely useful.

In the handling of the repair work, endeavor should be made by the foreman to specialize as much as possible; one man should be assigned to go over the electric headlight equipment, and another to side rod work. If the inspector is not too busy he can also tighten up all loose nuts that he finds, and look after the setting up of wedges and the replacing of tender journals. The renewal of piston rings and their examination should be at regular intervals, and at the time this is done the date should



Fig. 12—Iron Storage Rack

be stenciled on the inside of the cylinder casing. Thus R. 12-1-14 would indicate that the cylinder rings were renewed on this date, and if they were only examined, the letter E is used.

At a terminal of this size a heavy repair gaug should be maintained, independent of the running repair men, to handle the renewal of side rod bushings and driving box brasses, heavy repairs to motion work, the turning of tires and all work of a general repair nature. This will assist greatly in keeping the power out of the back shop longer. For the handling of side rods, couplers, air pumps, draw bars, and springs, a two-wheeled truck like that shown in Fig. 7 is convenient. This is made from 1½ in. iron with a yoke rising above the center line of the wheels, and a second hand pair of hand car wheels is used.

Most foremen at outside stations where they have only a small lathe have trouble when an engine comes in with a broken tumbling shaft, which requires a large lathe to swing it. To turn the ends without bending the arm, the device shown in Fig. 8 will prove of great value. A guide *A* is fitted into the tool rest and the fingers engage in the recess marked *B*. There is a key-way on the tapered center, and by using the feed this tool will do the work quite satisfactorily. The spring rack shown in Fig. 9 is made from 1 in. by 3 in. flat iron and needs no special description. The air motor shown in Fig. 10 has a saw for metallic packing on one end and the other will hold a drill socket for drilling staybolts, or it may be used for buffing. The center part of this air motor was made from an old side rod bushing, bored eccentric and fitted with slots in which are set four blades ¼ in. by 2 in. by 4 in.; the feed is through 1¼ in. pipe cut down

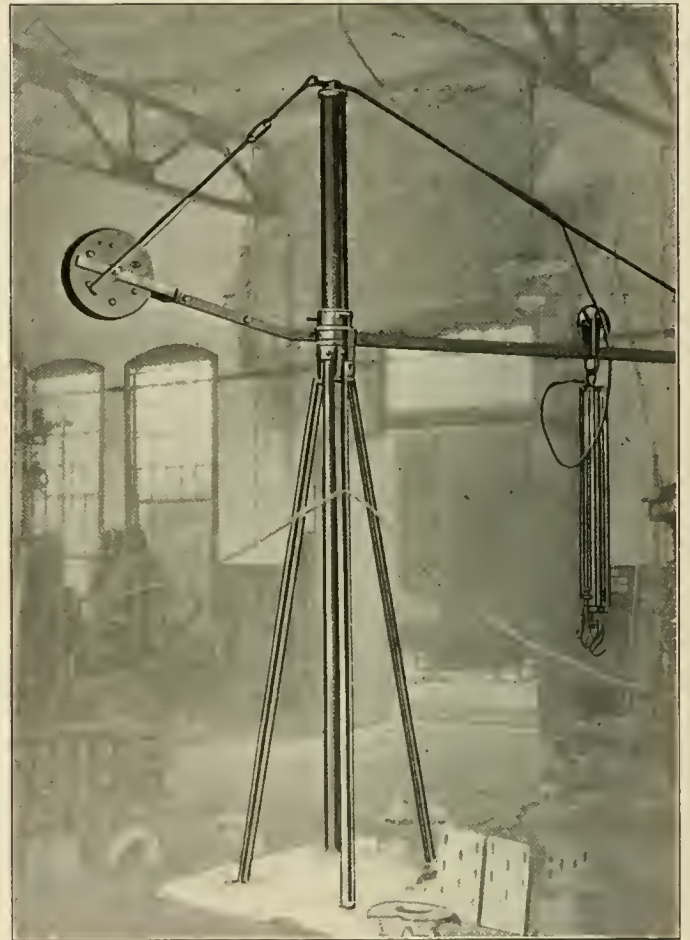

Fig. 13—Air Hoist and Crane

to ½ in. opening where it enters the motor and the exhaust is underneath. This avoids the use of hack saw blades.

The plates shown in Fig. 11 are for making metallic packing. They were made from second hand balance plates, and if care is taken in the molding, the packing does not require turning after it is made. Fig. 12 shows an iron storage rack which can also be used for tubes or piping. This is made from old rails held in place by ¾ in. bolts and iron pipe. The upper portion with the doors is for storing brass castings or other valuable material.

Fig. 13 shows an air hoist and crane which can be made very cheaply. The center pillar is made from a 6 in. piece of pipe and the side supports are small sized rails. The 6 in. pipe is screwed into a broken steam chest cover imbedded in concrete and the counterbalance is a piston head that was scrapped. The pipe itself was filled with concrete when put in position. This machine serves the planer, two drills and the hydraulic press. The carrier bar is a rail with the flat side up.

# MASTER BLACKSMITHS' CONVENTION

Including Papers on Spring-Making, Frame Repairing, Case-hardening, Heat Treatment of Metals and Shop Kinks

The twenty-second annual convention of the International Railroad Master Blacksmiths' Association was held August 18-20 at the Hotel Wisconsin, Milwaukee, Wis., H. E. Gamble, of the Pennsylvania Railroad at Altoona, Pa., president of the association, presiding. The opening prayer was offered by Dr. Levi and the association was welcomed to the city by the mayor of Milwaukee. Addresses of welcome were made by A. E. Manchester, superintendent of motive power; J. J. Hennessey, master car builder, and J. F. Devoy, assistant superintendent of motive power, of the Chicago, Milwaukee & St. Paul.

## PRESIDENT'S ADDRESS

The Pennsylvania Railroad in the year just closed carried 111,000,000 passengers without having a single train accident in which a passenger was killed. The blacksmith certainly played a part in this achievement. "Safety First" should be the watchword of this association. We are striving, and have been successful all these years, to find out the best ways and means to do our work, so as to protect the traveling public and the many companies we represent. Why not look up "Safety First" for those about us in the mills and shops, training the men under us to protect one another? We have in our smith shop at Altoona a smith whose duty it is to dress the heads of all tools from all over the plant, such as keys, drifts and pins, used so much in the boiler shop, as well as our own tools in the smith shop. Men will get careless, and we think that by having this smith set apart for this class of work we have prevented many an accident. A "Safety First" blacksmith is a good asset for any shop.

There is nothing like exchanging ideas. Let us all work for better methods in doing our work; stop, think and listen; always consult the men above you; be sure you are right; cultivate the habit of getting there, no matter what size shop you have. Come to these conventions and feel at home. Tell us something, it all counts; no member can afford to say nothing.

## ADDRESS BY A. E. MANCHESTER

A. E. Manchester, superintendent of motive power, Chicago, Milwaukee & St. Paul, addressed the convention in part as follows:

Your association is one of those that have helped, by better methods and management, to make up for some of the losses in the earnings due to increased taxes and higher rates for material and wages, railroading standing almost alone among the industries as the one that has steadily and constantly reduced the rates on the things it had for sale, namely, transportation, and at the same time has to a large extent improved its quality. But the unfortunate feature of this all is that the public, the purchasers and users of this commodity, fail to appreciate the fact that they are receiving the best and cheapest transportation in the world, and it ought to be one of the aims and efforts of every association to work for the bettering of the methods of railroad building, maintaining and operation, and let their lights so shine that wherever an opportunity affords they will bring forth these thoughts in a form that will help to bring a better understanding of true conditions to the minds of the general public.

To illustrate, the railroad with which I am associated has, since the year 1875, reduced its average rate of transportation from 2.5 cents per ton per mile to a rate of 0.79 cents per ton per mile for the year which closed June 30, 1913. You will see

from this that the road now receives an amount equal to one-third for the unit of service as compared with 1875.

Can you think of any other commodity that is today sold at any such a depreciated rate? When these matters are referred to, the answer will probably be that your railroad is vastly over-capitalized, and that you are looking for a return on a fictitious capital, but these statements are made without a true knowledge of the facts. As to the rate received for transportation, a year ago the average rate for all the railroads in the United States was 0.75 cents per ton per mile for moving freight. In England they received 2.5 cents, in Germany, 1.44 cents, and in France 1.39 cents. If the rates received in the United States were equal to those paid in the European countries, the railroads here could readily meet almost any demand that might be made upon them so far as taxation, rates of pay, etc., went and still pay a reasonable dividend on the investment in the property.

I recall a few years ago attending a political meeting, in which the speaker was trying to show what great things his party had done for the good of the people of Wisconsin. He said, "We are building in Madison a new capitol building; it will be one of the finest in the United States, and will cost about \$6,000,000 to build. You will not have to pay one penny of the cost of building that building; it will all be taken out of the railroads." And the people cheered; that was a great hit. The party was getting something for nothing, and they were to get the benefits. It is such a feeling and spirit as this that has got to be corrected and better understood before railroads will have a fair chance to maintain or improve their conditions.

## CARBON AND HIGH SPEED STEEL

George F. Hinkens, Westinghouse Air Brake Company: To determine the proper forging heat for high speed steel is a matter of experience on the part of the tool smith. Care must be exercised not to work it at too low a heat, as it will cause the crystals to crush and rupture. It is dangerous to forge it after the temperature has dropped below a bright yellow. There are as many methods for hardening high speed steel as there are brands. One method that gives good results is to heat slowly up to the sweating point, or about 2,200 deg. F., after which cool the cutting point of the tool in oil (if lathe or planer tool), and when thoroughly black, cool rapidly in compressed air blast. In hardening taps, threading dies, reamers and milling cutters made from high speed tool steel, it is good practice to insist on slow pre-heating in a furnace at a temperature of 1,500 deg. F. and then submit to a temperature of 2,200 deg. F. or move to an adjacent furnace.

The Westinghouse Air Brake Company anneal high speed steel by placing it in a tube or pipe large enough in diameter and length to accommodate the work. Both ends of the tube are provided with a screw cap. After the work is placed in the tube and before screwing on the cap we put in from a tablespoonful to a handful of resin, screw on the cap, heat for six hours and let the pipe and contents cool with furnace gradually to atmospheric temperature. Work of large bulk is heated in an open furnace at 1,450 deg. F. for six hours. It is then removed and buried in hot burnt casehardening compounds or extremely hot ashes and left there until cold.

Furnaces used for hardening high speed steel should be so constructed that the oxygen of the air from the blast and fuel opening will not attack the metal, as this would result in scale, blisters, uneven heating, cracking in hardening and general bad results. A furnace within a furnace would be



ideal. Such a furnace would prevent the oxygen of the air from attacking the work and would be suitable for large pieces, such as drop hammer dies. For smaller pieces a muffle should be used.

H. A. Hatfield, Canadian Car & Foundry Company: In ordering steel a careful study should be made of the conditions to be taken care of and full information furnished with the order; by doing this there can be no misunderstanding of what grade of steel is required and the manufacturer will be in a better position to provide the steel required.

By testing new bars of steel for hardness and stamping each piece taken from it with the hardness number it will enable the tool smith to better regulate his work and permit of establishing standards that will give the best results. Considerable information can be gained from an examination

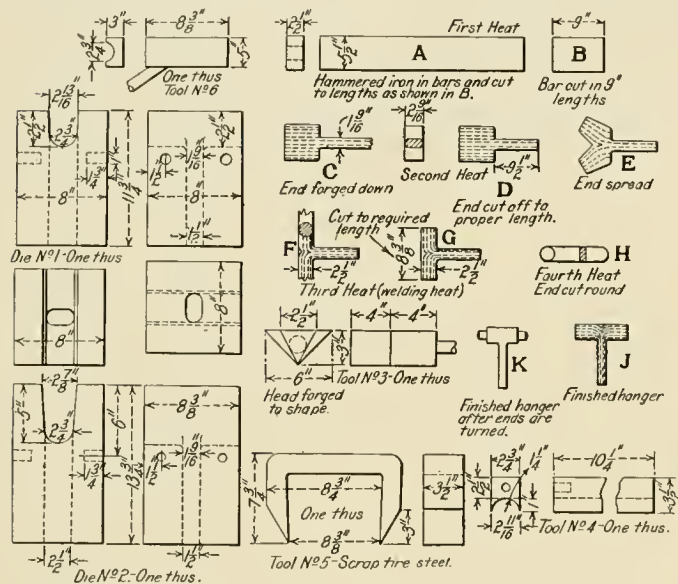

Fig. 1—Dies for Forging Spring Hangers for Tender Trucks

of the fracture of the bar when it is broken, provided it is broken under standard conditions, that will aid the expert tool smith in hardening the tools. The hardness testing machine is of particular value in establishing standards and its constant use is advisable for this end. In doing this work the tools of different hardnesses should be watched carefully in the shop and their service noted. Its use will also permit of making more detailed requisitions for material. The hardness alone, however, does not indicate the perfect tool, for oftentimes overheated tools may have the requisite hardness and break on account of being overheated.

In selecting a furnace a design should be chosen that may be readily repaired. The burner provided should permit of close regulation. In fact, every point should be carefully considered. The direct vision spectroscope has been found very satisfactory in determining the temperature of the work in the furnace.

**TOOLS AND FORMERS**

H. G. Sharpley, Lima Locomotive Corporation: With the introduction of the modern smith shop machines it is necessary for the smith shop foreman to devise suitable tools and formers to use in them so that they may develop the greatest efficiency. In doing this the total cost must be carefully considered and this should include the increased overhead expense occasioned by the more expensive machines. The smith shop foreman must keep in close touch with the foreman of the tool room and co-operate with him in keeping the tools in proper working condition.

J. W. McDonald, Pennsylvania Railroad: The following dies and formers are very easily made and have given good results:

Fig. 1 shows the dies and method of forging spring hangers used on tender trucks. On account of not having a forging machine large enough to make these hangers, I was compelled to make them under a steam hammer. The stock A is roughed down to size and cut to length as shown at B. It is then reheated and the end reduced as shown at C. The end is then cut to length as shown at D. The forging is then placed in die No. 1, and with tool No. 3 the top is spread so as to start the fibres of iron as shown at E. In the next operation the iron is reheated to a welding heat, placed in die No. 2, and, using tool No. 4, the top end is forged down as shown at F. With the same heat and the same die with tool No. 5, both ends of the hanger are cut off at the same time to proper length as shown at G. In the fourth heat the bottom of the hanger is cut half round as shown at H and J. This completes the hanger in the rough; K shows the finished hanger after the ends are turned on the machine. Several of these hangers after being completed in the rough were sawed in about six or eight sections, then given an acid test to learn positively if the fibre of the metal had the flow in the proper direction. In all cases it was found that the metal had flown as intended and as indicated by the dotted lines at G and J. The finished hanger is shown in Fig. 2

Fig. 3 shows dies for hending steam pipe flanges on a pneumatic bending machine equipped with an 18 in. cylinder, 30 3/4 in. stroke. With this attachment you can produce work of this kind at a very low cost, as well as reducing the hard labor that is involved when they are made by hand. These rings are as near perfect as can be made. You will note that the ends of the iron do not meet within 3/4 in. This allowance is made for scarfing which is done on one side only. The plunger head is bridged to allow the ends of the rings to pass under while

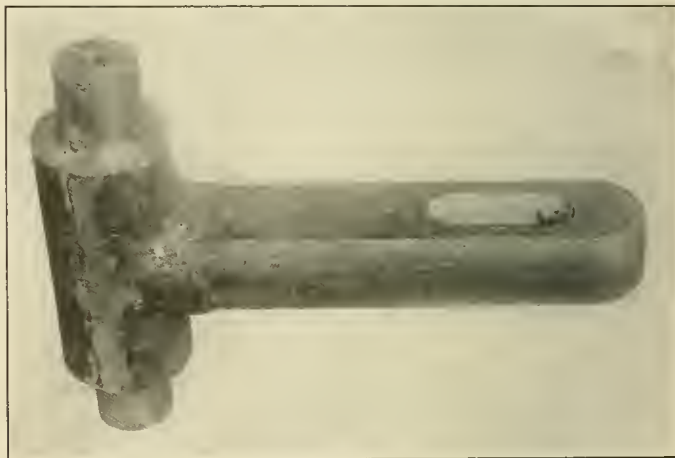

Fig. 2—Finished Hanger Made in the Die Shown in Fig. 1

bending; also the head is hinged on the back end so that it may be raised to remove the ring after bending. An elliptical ring is formed with the same die by using a shoe on the face of both formers, corresponding to the shape of the ring desired. When welding either ring, use round iron to fill in the scarf. This is accomplished by taking a separate heat on each piece, and permits of welding in one heat.

Fig. 4 shows dies for making ashpan connecting jaws. The amount of metal required to make this jaw cannot be gathered from a 5/8 in. by 2 in. bar. To overcome this difficulty we first punch pieces to the shape shown at A. We then punch a 7/16 in. hole on the 1 15/16 in. end, and also punch a 7/16 in. hole in the straight piece of 3/8 in. by 2 in. iron, then rivet the three parts together just sufficient to carry them to the machine for welding. The completed forging is shown in Fig. 5. In this way we get a very satisfactory job at a very low cost, as there is no slotting work necessary. Up until the time we designed this die, this piece was forged solid at the steam hammer, and the center was slotted out in the machine shop. The cost for





On the Chicago & North Western the practice is to make all the springs in the Chicago shops for the whole system. The springs are carefully tested and standard lengths of spring hangers are used so that the springs will not be unduly compressed in application. As the old springs pass through the shops they are brought up to standard. Carbon steel is used entirely on this road.

**FRAME MAKING AND REPAIRING**

Geo. Hutton, New York Central & Hudson River: By means of the electric welding process and the oxy-acetylene



**Fig. 5—Jaws Made in the Dies Shown in Fig. 4**

burners it is now possible to make most any weld on the engine. At our West Albany shops we have not had a frame off an engine on account of breakage in eight months and only three in two years. All the welding is done by electricity; we have not used oil in two years. A point that should be carefully considered in making frames is the annealing and heat treatment of them, especially cast steel and vanadium. I believe that much better results will be

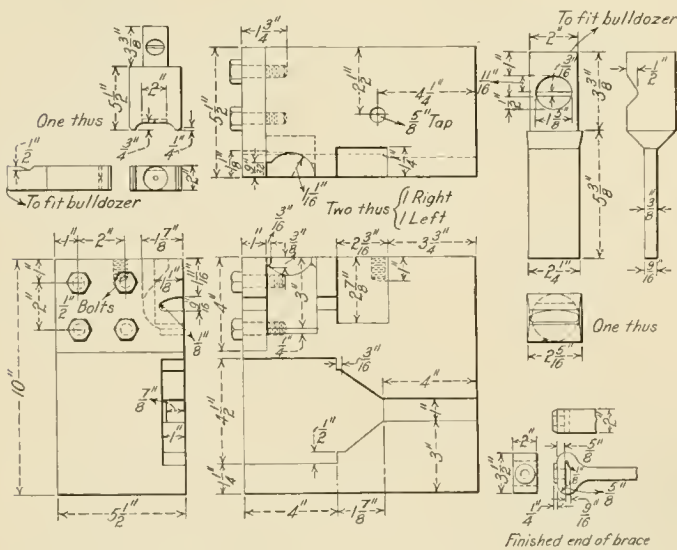

**Fig. 6—Dies for Forging the Back End of Back Tube Sheet Braces**

obtained and much less breakage experienced if all frames are heat treated as well as annealed.

C. E. Lewis, Pennsylvania Railroad, Baltimore: The best way to weld a frame is at the forge, but often it is not expedient to remove the frame from the engine and in this case good judgment must be used. When cost is considered oil is cheaper than Thermit and the work can be done more quickly.

There are many places where Thermit can be used and oil cannot. The main point in welding a frame is to see that it is properly preheated. All welded frames should be annealed after welding by leaving the furnaces on until the frame has become cool.

Ill-fitting pedestal caps and the drop of engines on turntables, which often amounts to as much as 3 in., are a great cause of frame breakages. The practice of applying clamps to frames rather than welding them at once is bad practice, as it is liable to cause the frame to break in other places.

J. N. Poland, Richmond, Fredricksburg & Potomac: We use both the Thermit and the electric welding processes and both give excellent results. Out of 65 frames welded by

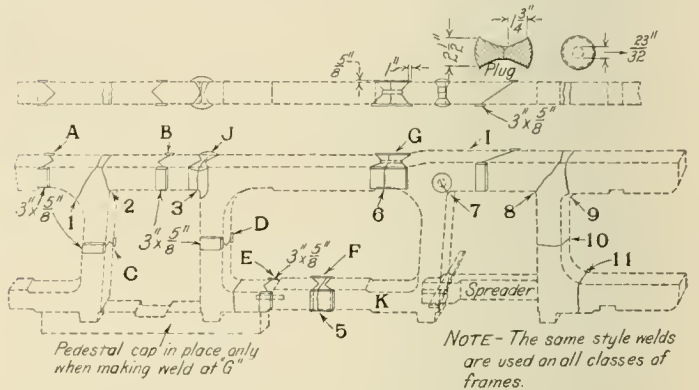

**Fig. 7—Method of Making Oil Welds in a Locomotive Frame**

**NOTE**

- 1—When a frame is broken at the pedestal as shown at 1 or 2, the corner is cut out at A, B and C, the ends shaped and a new corner is then fitted and placed in position. Pieces of iron 3 in. by 3/8 in. are fastened with a small stud on each side of the frame at the points where welds A, B and C are to be made, with the grain of the metal running parallel with the grain in the frame; then each point is heated and welded.
- 2—When the frame is broken at the pedestal as shown at 3, the frame is cut out as shown and a piece of metal is shaped to fit and allowed to extend beyond each side of the frame; heat is then applied and the weld made.
- 3—When the frame is broken at the heel of the pedestal as shown at 4, the heel is cut off at D and E, a new piece fitted and a 1-in. d weld pin inserted at E to carry the weight of the heel and keep it in line while welding; pieces of iron are placed at the weld as in the case of breaks 1 and 2. Heat is applied and the weld made at E and then at D.
- 4—When the bottom member of the frame is broken as shown at 5 the frame is cut out, block fitted, plates put in position and the weld made at F.
- 5—When the top member of the frame is broken through the spring hanger opening as at 6, the frame is cut out on each side of the opening the full length of the slot, the spreader is then placed between the pedestal jaws and expanded until the opening at 6 is increased 5/16 in., then a block is fitted and plates applied as at G. A charcoal fire is then applied to the bottom member of the frame at K (but no heat is not permitted); at the same time heat is applied to G for making the weld. The charcoal fire is to be removed after the weld is made to allow the weld and bottom member to cool evenly. The spreader should be released gradually as the temperature of the frame decreases.
- 6—When the main frame is broken at the front end as shown at 8, 9, 10 and 11, the end back to I is removed and a new end is fitted and bolted to the front frame and heat applied. As the temperature increases the spreader between the pedestal jaws should be expanded and the weld made at J. The spreader should be released gradually as the temperature of the frame decreases.
- 7—When the top corner of a pedestal is cracked at 7, a 29/32-in. hole is drilled through the frame at the end of the crack, then counterbored 1 3/4 in. deep on each side by 2 1/2 in. in diameter outside. Two plugs are fitted, one on each side, coming together as shown in the small sketch; heat is applied and the weld made at H. The grain in all fitting blocks and plates should run parallel with the grain in frame.

electricity only one has broken and that was on account of being made too close to a Thermit weld. It has been found that the electric process will not weld Thermit metal. In welding frames two men are required, so that the metal may be filled in on both sides at the same time. The frame is heated before starting to weld and the welding done quickly in order to avoid too much expansion.

U. R. Pratt, Charleston & Western Carolina: Thermit is the best material to be used when it is impossible to take the frame into the smith shop for repairs. Good hammered iron frames give much the better results and our records show that they cost less for repairs. Where possible we cut out V's on both sides of the break, clamp up the frame

and weld in dutchmen on both sides, making sure that the grain runs the same as the frame.

DISCUSSION

Several members stated that they believed better results could be obtained with cast steel frames if they were heat-treated in addition to being annealed, as it was believed that the annealing did not remove all of the internal strain. The various processes of frame welding, oil, Thermit and electric,

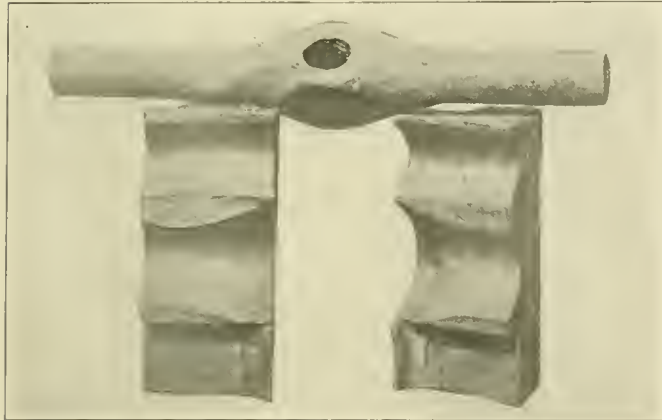

Fig. 8—Spike Maul and Dies for Forming It

all had their adherents, several members having obtained first class results with all of these processes. It was the consensus of opinion, however, that where possible broken frames should be taken to the shop for repairs, as it was believed that a more substantial weld could be made on the forge fire.

J. S. Sullivan, Pittsburgh, Cincinnati, Chicago & St. Louis, described his method of repairing cracks in the fillets at the head of the pedestal jaws. Two holes are drilled at the end of the crack and on each side for the full depth of the crack. The frame is then heated and a chisel bar is placed on the bridge between the holes and driven in. This forces the metal out and welds the crack, the fillet being hammered back into shape with a fuller. A dutchman is used when the crack extends all the way through, a hole being drilled through the frame at the end of the crack.

J. W. McDonald, Pennsylvania Railroad, presented a draw-

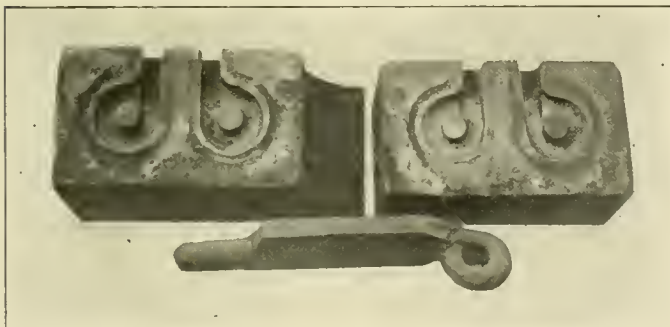

Fig. 9—Steam Hammer Die for Making Safety Chain Plates

ing showing the methods of welding locomotive frames with oil without removing them from the engine. This is shown in Fig. 7.

OXY-ACETYLENE WELDING AND CUTTING

T. E. Williams, Chicago & North Western, gave a general description of the oxy-acetylene process and stated that the oxy-acetylene outfits have a wide range of usefulness and where used have met with success in welding broken castings, locomotive boilers, and other general items. One of

the most striking examples is that of building up flat stops on tires. The old method would require the tire to be turned off at a total expense of about \$100, whereas they can be placed in good condition by welding with oxy-acetylene for \$6.21. A broken spoke in a trailing wheel was repaired by oxy-acetylene for \$7.41, making a saving of \$32.59. This process can also be used in building up worn holes in cross-head shoes, crossheads, etc., making a very material saving.

CASEHARDENING

P. T. Lavender, Norfolk & Western: At the Roanoke shops we use a 20 in. by 20 in. by 48 in. cast iron box for case-hardening. A 2 in. layer of burnt bone is placed on the bottom and the material to be hardened is placed on this about 3/4 in. apart, special care being taken that no two pieces touch. Raw bone is packed between each two pieces. When the box is full it is covered with a 2 in. layer of bone and a lid made of boiler plate covers the box. By using this it is not necessary to use fire clay. A semi-muffled furnace having a perforated arch between the box and the combustion chamber is used. This furnace has flues in the wall opposite the burner that run down to the bottom, giving an outlet under the bottom of the box. This provides a uniform heat. The box is heated to about 1,450 deg. F. and held at that temperature for about 12 hours. The material is then removed and quenched in cold running water. This process gives a casehardening about 1/16 in. to 3/32 in. deep.

D. Huskey, Chicago Great Western: We use a steel box in which is placed a layer of charcoal. On top of this is

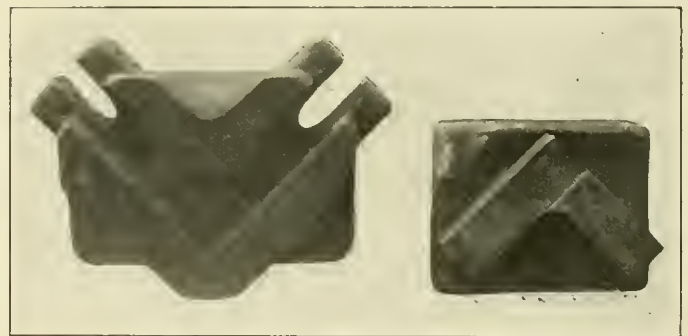

Fig. 10—Dies for Making Engine Truck Frames

firmly packed a 1 1/2 in. layer of cyanide and salt mixture. The material to be hardened is placed on top of this about 1/2 in. apart and is covered with a layer of cyanide and salt. This process is repeated until the box is filled and it is then covered and sealed with fire clay or sand. The box is heated in an oil furnace to about a lemon color and kept at that heat for from nine to twelve hours. This system produces a casehardened surface about 3/32 in. to 5/64 in. deep.

HEAT TREATMENT OF METALS

H. E. Gamble, Pennsylvania Railroad: The Pennsylvania Railroad has carried on quite a little experimental work in the heat treatment of metals for the last three or four years, but it was not until January 1, 1913, that they decided to apply heat treatment to their locomotives. They have now at the Juniata shops a complete heat-treating plant for the reciprocating parts of all locomotives. Included in these parts are main rods, side rods, axles, crank pins, piston rods, and valve motion parts, as well as a varied line of miscellaneous work. The plant is located in one of the smith shops, and occupies about 60 ft. by 100 ft. of floor space. There has been installed a cylindrical oil-fired furnace, 6 ft. in diameter inside by 16 ft. 6 in. deep, in conjunction with a quenching tank 14 ft. square and 20 ft. deep. The tank is located at the right of the furnace. Next to the tank on the right is



located a horizontal muffle type furnace, oil fired, with a heating chamber 7 ft. wide, 14 ft. long and 30 in. high, the hearth of this furnace being constructed on a car.

A small horizontal muffle type furnace, oil fired, with a heating chamber 4 ft. wide, 7 ft. long and 12 in. high is located near at hand, with oil and water tanks conveniently located, for small work. An electric furnace, with a heating chamber 8 in. by 8 in. by 18 in. long is used for experimental work and the calibration of pyrometers. A crane of 12½ tons capacity, and a span of 54 ft. was installed for handling the work in and out of the furnaces and tanks. The vertical furnace mentioned above is contained in a concrete lined pit, about 12 ft. square and 13 ft. deep, one side of the pit being common with the quenching tank. The furnace is supplied with eight low pressure oil burners, the flame from which is admitted to the furnace at a tangent to the inside circumference. The quenching tank is built of concrete, the sides extending above the floor line about 3 ft. It is lined throughout with 4 in. by 8 in. yellow pine, to protect the sides and bottom from injury. Water is admitted at two points near the bottom through two 4 in. pipes, and passes off at the top through two 6 in. pipes.

While this plant has only been in operation about a year, we have handled quite a lot of steel, including various alloys, such as chrome vanadium, Mayari and nickel; also special chrome. Although we have obtained some very fine results on the alloy axles, we are handling mostly carbon steel, which, after heat treatment, gives us good satisfaction. Our method of treatment of the carbon steel axles is as follows: Heat in the vertical furnace eight hours after the furnace assumes a constant temperature of 1,550 deg. F., quench in water about 70 deg. F. for eight minutes, reheat in the horizontal furnace for eight hours after reaching a constant temperature of between 1,100 and 1,200 deg., then cool in the air after placing on rails in a pyramid, so the parts will cool slowly. A physical test is taken of all heat-treated parts. The sample is taken with a hollow drill, which cuts a core 7/8 in. in diameter by 6 in. long. This work is done on a horizontal boring machine. The physical tests require an elastic limit of 85,000 lb. per sq. in., and an ultimate strength of 120,000 lb. per sq. in., with 20 per cent elongation and 50 per cent reduction in area. Mayari axles are heated to 1,500 deg. F., quenched in water at 70 deg., and reheated to 1,055 deg. F., and allowed to cool in air. The physical tests re-

85,000 lb., an elastic limit of over 50,000 lb., an elongation of 20 per cent and a reduction in area of 40 per cent. If the axles pass the physical test, they are given a drop test. Main rods, side rods, piston rods and all long work is handled in a similar manner. Crank pins, return cranks, valve stems, crossheads, crosshead pins, crosshead keys, etc., are handled in the small horizontal furnace, the method of treatment being practically the same.

John M. Keller, Purdue University, submitted to the association a copy of the practice recommended by the American Society for Testing Materials for annealing miscellaneous rolled and forged carbon steel objects as published in their proceedings of 1911.

SHOP KINKS

W. C. Scofield, Illinois Central: Fig. 8 shows dies for a power hammer for drawing out, cutting off and finishing a spike maul in one heat.

Fig. 9 shows a steam hammer die for making ends for safety

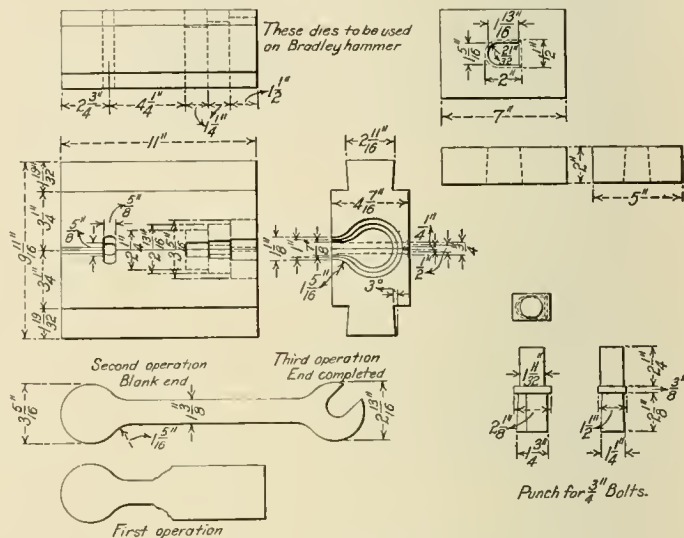

Fig. 12—Dies for Forming Wrenches from Scrap Spring Steel

chains for passenger coaches. The forging is roughed out before using the die. It will be noticed there are two impressions in dies, making it appear as though the forgings are right and left, which is not the case, but the shape of the forging makes it necessary. The heated blank is first placed in one impression and taken out, turned over and placed in the other impression, and as the impression in the bottom die is 1/8 in. deeper than that in the top, this will trim off the flash. This makes a first-class forging and has every appearance of a drop forging.

Fig. 10 shows steam hammer dies for making engine truck frames. It is our practice to draw out bars from scrap iron axles. The first operation is to place the long and short pieces in the dies between adjustable stops and weld under the hammer. The two halves are then clamped together in a jig, heated, and the corners welded in the same die. In the second operation the frame is handled in a crane. This makes a good job and when made in any quantity will prove a paying investment.

Fig. 11 shows steam hammer dies for shaping the ends on new and repaired driver brake beams. In repairing, the end of the beam is brought to a welding heat in a suitable furnace and, at the same time, a piece large enough to fill the worn place is heated welding hot and laid on the end of the beam and welded in the dies. It is turned over in the same impression and trimmed, the bottom being 1/8 in. deeper than the top. It is then placed in the finishing swage in the dies and by using a little water a smooth clean job is made. The end is cut off to the proper length in the dies.

C. V. Landrum, Nashville, Chattanooga & St. Louis: Cast steel

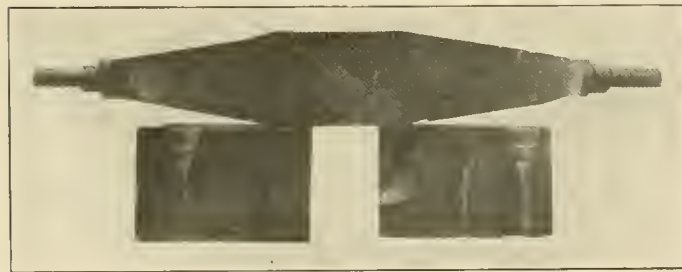

Fig. 11—Dies for Shaping and Repairing Driver Brake Beams

quire a 70,000 lb. per sq. in. elastic limit, a 100,000 lb. per sq. in. ultimate strength, with 20 per cent elongation and 50 per cent reduction in area.

Main rods, side rods, piston rods, crank pins, etc., follow practically the same treatment, except in the time of heating and the quenching. We have also found that heat treatment has been of service in our miscellaneous work, such as bolt headers, dies, latch blocks, milling machine arbors, hammer rods and lifting devices. In connection with our heat-treating work we have a laboratory which is equipped for obtaining chemical analyses of all steels, also a 100,000 lb. tensile machine on which are made the physical tests. The carbon steel axles are required to have an ultimate tensile strength of

truck bolsters often break about midway between the center bearing and the end, where there are two holes. These are repaired by placing a  $\frac{3}{4}$  in. by 7 in. piece of Empire steel or  $\frac{7}{8}$  in. by 7 in. iron across the face and up 3 or 4 in. on each side. They are then placed in a fire with the edge down and a welding heat taken for 2 in. up the side. It is worked with a flatter on a cast iron block and then turned up edgewise and swedged. These are repaired at \$2 per side, and of the 400 we have done not one has failed at the weld.

W. J. King, Illinois Central, is doing a great deal in reclaiming second-hand iron. The old arch bars are being worked into brake levers and safety hangers, and the round iron into bolts, safety hangers, or anything that can be made from second-hand iron. Old transoms are used for knuckle plates and are also made into new transoms. Old bolts are saved by piecing them out. This work is done by inexpensive handymen, who have kept the plant in bolts for the past five months, eliminating the necessity of making new bolts. Small scrap springs are being

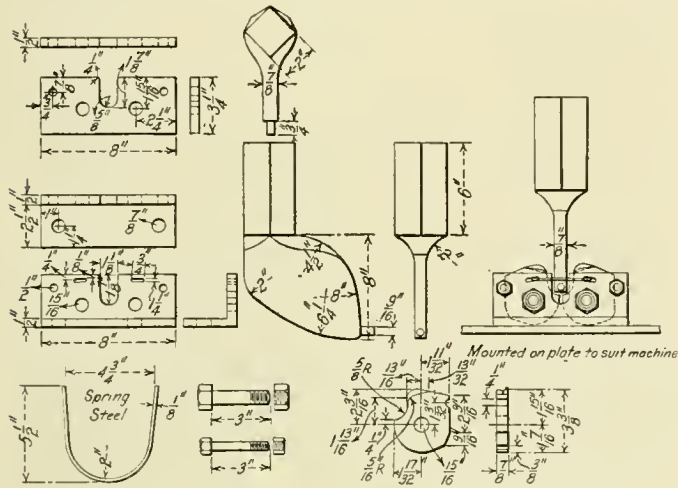

Fig. 13—Dies for Bending Cellar Bolts In a Power Punch

made into ripping bars for the car men, and the packing hooks and paddles used in packing hot boxes are made out of discarded 8 in. air cylinder springs. Old tools in the machine shop are being reworked into smaller tools and small high speed steel tools are made for use in tool-holders, all these tools being marked so that the grade may be readily distinguished.

J. W. Riley, Lehigh Valley: Fig. 12 shows dies for forming wrenches from scrap spring steel under the Bradley hammer. These dies can also be used under a steam hammer. By this method a wrench can be made  $\frac{9}{16}$  in. thick from  $\frac{3}{8}$  in. scrap spring leaves. These wrenches are forged in two heats and one man can forge on an average of 150 blanks in 10 hours. After they are forged they are punched hot on a power punch with a close-fitting die and are then rattled until they are polished. They are then sized on a small emery wheel where one man can grind 300 in 10 hours. One man will also heat and punch 300 in 10 hours in sizes ranging from  $\frac{3}{8}$  in. to  $1\frac{1}{4}$  in. Wrenches too large to be made from spring steel are forged from tire steel to the required size and handled the same as with spring steel after it has been annealed. We have made 4,500 wrenches during the past 18 months and they all seem to have given good satisfaction.

Fig. 13 shows dies for bending cellar bolts. These dies may be used on any power punch by having the plunger out far enough to clear the punch. With this tool a bolt may be bent at every stroke of the machine and the short ends can be worked up into cotter pins.

A power punch is a very valuable machine in a shop. The following is some of the work we perform with it: Bending grab-irons, sill steps, pin lifters, pipe clamps, corner bands, pin-lifter brackets, brake hangers, cellar bolts, calker pins, lad-

der uprights, running board brackets and brake step brackets.

During the past year 400,000 grabirons were forged in the shops at Sayre, Pa., the dies in Fig. 14 being used. These dies are placed in an old four-hammer bolt machine with the sides and bottom hammers removed. A shear blade is attached to the top hammer and a bottom shear blade is placed across for shearing off the burrs which are on the bottom of the foot as the hole is punched nearly through by a button on the header. A punch die is arranged in front of the shear blade and the punch is attached to an extension bar which is placed in the header holder. The button on the header saves nearly 90 ft. of iron in a thousand grabirons and the button serves as a gage when upsetting the second end. Two men will upset 6,430 ends complete in 10 hours. One man will punch and trim the burrs on 10,000 ends in 10 hours and one man will make a single bend under the punch of 9,000 ends in 10 hours.

H. E. Gamble, Pennsylvania Railroad: Steel plate for piling scrap has been a great success in the Juniata smith shop. We have been using this kink for about four years and the saving in the use of lumber has been worth while; also the amount of sand necessary to keep up the furnace bed has been reduced, as when wood was used for the piles it would burn up and produce rough spots or eat holes in the bed of the furnace, in which sand would have to be used freely, causing delay in charging up the next heat. The steel plate does not remain in the furnace longer than is required for the men to shove the pile of scrap on to the furnace bed. We use a plate 12 in. by 20 in. to form a bloom weighing from 500 lb. to 1,000 lb.

OTHER BUSINESS

Other papers were presented by Thomas F. Keane (Ramapo Iron Works) on Electric Welding, in which the various systems were thoroughly described, and by W. F. Stanton (J. A. Fay &

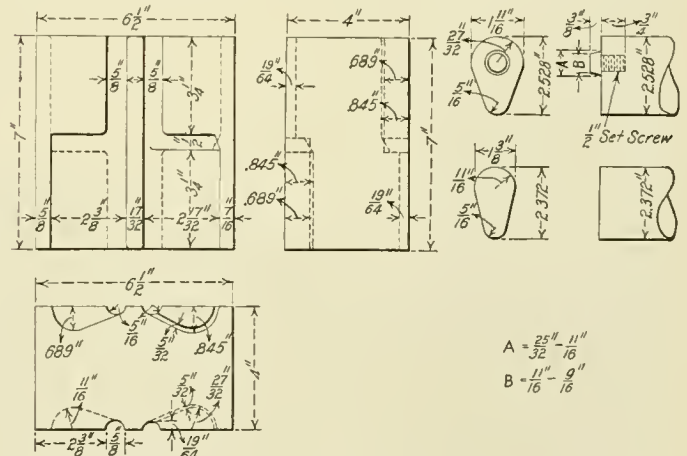

Fig. 14—Dies for Forging Grab Irons

Egan Company) on Making and Repairing Frogs and Crossings. The secretary reported a membership of 323.

The following officers were elected for the ensuing year: President, T. F. Buckley, Delaware, Lackawanna & Western; first vice-president, T. E. Williams, Chicago & North Western; second vice-president, W. C. Scofield, Illinois Central; secretary-treasurer, A. L. Woodworth, Cincinnati, Hamilton & Dayton; assistant secretary-treasurer, George P. White, Missouri, Kansas & Texas; chemist, G. H. Williams, Boston, Mass.

Philadelphia received the greatest number of votes for the next convention. After the adjournment of the convention the members visited the Milwaukee shops of the Chicago, Milwaukee & St. Paul, and the shops of the Allis-Chalmers Manufacturing Company.

INVENTION OF LOGARITHMS.—The three-hundredth anniversary of the invention of logarithms by John Napier is to be celebrated this year.



### GOGGLES IN RAILROAD SHOPS

One of the frequently recurring classes of injury to which railway shop employees are subjected is injury to the eyes by flying particles or chips of metal. Thousands of such injuries have occurred annually, some of them resulting in loss of sight, and many in entire loss of the eye. The use of goggles as a means of eye protection has been made a part of the safety campaigns of a number of railroads and, as is generally the case with safety movements, considerable effort has been necessary to secure effective co-operation on the part of the persons concerned.

On the New York Central Lines the use of goggles by employees who are doing work which is hazardous to the eyes has proved so effective that a campaign of education has been inaugurated by the general safety agent, in an effort to get every employee doing such work to use this means of eye protection at all times. During the year 1913 2,499 employees received eye injuries, practically all of which it is believed could have been prevented by the use of goggles. There has not been a case since their introduction where injury has been sustained from splintered glass, and several instances are reported where goggles not only saved the sight of an eye, but where the eye was undoubtedly saved from being gouged out by a flying piece of steel.

The goggles furnished by the company are known as the Saniglas, the lenses of which are of a specially ground clear glass which does not break except under an extraordinary blow. Each employee whose eyes are endangered by the class of work to which he is assigned is provided by his foreman with a fitted pair for his individual use. In order to impress upon the men the necessity of always wearing them when at work, the bulletin shown in the illustration has recently been placed in the principal shops of the system. It shows in a striking manner the protection afforded by the goggles. An illustrated circular has also been distributed to all shop employees. This is printed in four languages: English, German, Polish and Italian, and gives a number of concrete examples with illustrations emphasizing the risks taken when working with the eyes unprotected.

### REMOVING STAND PIPES

BY R. F. CALVERT

The accompanying sketch shows a device used at the Horton, Kan., shops of the Rock Island lines for handling stand pipes when stripping and erecting engines under general repairs.

This device is made from an old piece of 1½ in. gas pipe. The two ends as shown in the illustration are flattened and slotted for about 3 in. to accommodate the variety of sizes of steam domes. The pipe is bent to the shape shown and a 3 in.

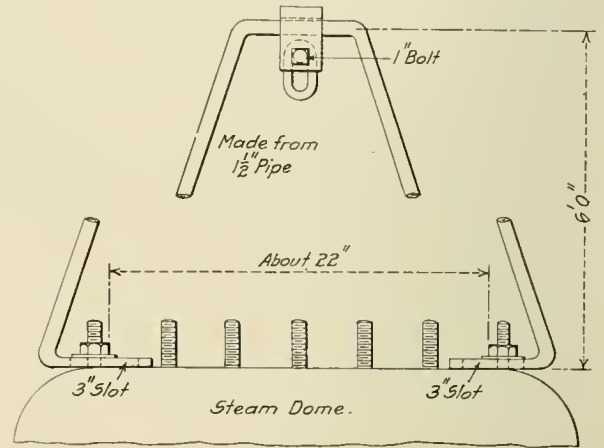

Device for Removing Stand Pipes from Steam Domes

eye bolt fastened to the top for use with a rope fall or chain hoist. It was thought at first that some means of staying would have to be provided, but after the attachment had been used a few times this was found unnecessary if care was taken to select two dome studs diametrically opposite each other. The upper half is guided by the guide pins shown. While the staff is being held tight the machine is started and the two punches B and C punch the holes, the end being sheared by the blade E.

## OBJECT LESSON ON GOGGLES

<b>THE MEN WHO DID NOT WEAR GOGGLES</b>	<b>THE MEN WHO DID WEAR GOGGLES</b>
<b>GOGGLES THAT SAVED MANY EYE INJURIES</b>	
<b>WHEN YOU DO WORK THAT REQUIRES GOGGLES WEAR THEM BY ALL MEANS</b>	

Goggles as a Means of Eye Protection on the New York Central Lines

# NEW DEVICES

## HORIZONTAL BORING, DRILLING AND MILLING MACHINE

A horizontal boring, drilling and milling machine with duplex control throughout has been developed by the Niles-Bement-Pond Company, New York. This machine is of the elevating spindle type, and as shown in the illustrations, is symmetrical throughout with respect to the spindle axis, permitting the operator to stand on either side and have all controlling levers within convenient reach. It is adapted for work requiring great accuracy, but the design being free from delicate parts, it is equally suitable for heavy boring service.

One of the important features of this machine is the location of the spindle saddle within the post. This makes possible the symmetrical construction of the entire machine about the spindle

The outboard column is made in two parts; the lower portion is gibbed to the bed and has longitudinal adjustment; the upper portion is bolted and doweled to the lower so that it may be removed for long pieces of work and easily replaced in correct alinement. Provision is made for disconnecting the vertical lifting screw from its operating mechanism in order that dismantling any part of the gearing may be unnecessary when the post is removed.

The table has a very large working surface with T-slots for holding the work. It is gibbed to a broad saddle large enough to support it at the extreme position of its travel. The saddle is adjustable along the bed by hand or by power through a screw running between the tracks of the bed. The bearings of the table on the saddle and those of the saddle on the bed are both gibbed with square locks in which provision has been made for adjustment for wear. The table is provided with power cross feed for milling and rapid power traverse for quick adjustment.

The bed has an unusually wide top, presenting a liberal surface for the table saddle bearing. It has broad flanges at the bottom and is braced inside with frequent cross ribs. The top is entirely closed to prevent chips from falling inside. Within the table are the driving, feed and traverse gears. The driving gears run in an oil bath and the feed and traverse gears are lubricated by the splash system. Large cover plates on both sides of the bed provide a means of ready access to the gearing for examination. Power feeds are provided as follows: Horizontal feed of the spindle for boring and drilling; vertical feed of the spindle saddle and cross feed of the table for milling. An

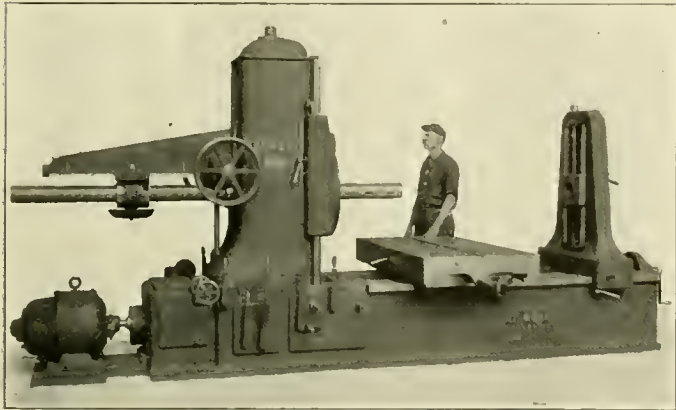

Horizontal Boring, Drilling and Milling Machine

axis and affords a very rigid support for the spindle. The thrust is taken on two V tracks, one on either side of the spindle, eliminating the distorting strains which are inevitable in machines having the spindle and saddle on the front of the post. The thrust, coming squarely against the bearing of the saddle on the post, tends to add to the truth of the alinement. The saddle has a vertical power feed for milling as well as a rapid power traverse. This motion is transmitted through a vertical screw which is connected by gearing to a similar screw in the outboard post, so that the spindle saddle and outer bearing always move in unison. The spindle driving gear is enclosed within the saddle with a portion extending outward and exposed for use as a face plate.

The spindle slides in a long sleeve which revolves in removable bearings, the main bearing being tapered so that adjustment may be made for wear. The spindle is driven through two large spline keys set into the sleeve and engaging keyways in the spindle. It is fed and rapidly traversed by means of a screw in the saddle horn.

The spindle column is of box form, open through the center but connected at the bottom in one continuous casting. It is closed at the top by a cap tongued and grooved into the two sides, thus making a very rigid structure. It is strengthened inside by ribs located in the best manner for resisting backward and torsional strains. The V tracks for the saddle traverse on the front of the column have unequal sides. The faces toward the outside of the column are broad, presenting a liberal bearing surface against the thrust of the saddle while the faces toward the inside are at approximately right angles to the others for resisting side thrust.

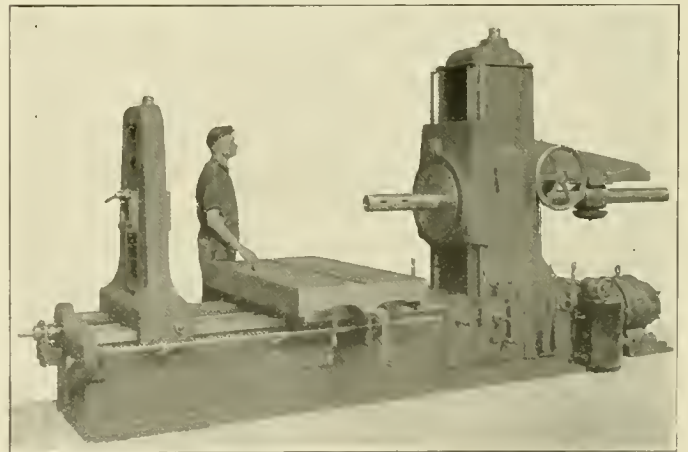

Duplex Control Symmetrically Arranged About the Spindle Axis

automatic feed may also be provided for circular motion of the standard table or in connection with a round table. All feeds are reversible and are not affected in amount per revolution by changes in the spindle speed.

An auxiliary work support, consisting of a narrow casting extending across the bed, is furnished if required. It has adjustment on the bed and is of the same height as the regular work table. It is provided with a T-slot in the top surface for clamping the work. A facing head has also been designed which may be attached either to the face plate gear or to the boring bar. It is provided with automatic radial feeds by adjustable fingers and star wheel. The machine may be driven by variable speed direct current motor, cone pulley and countershaft, single pulley and speed box, multi-speed alternating current motor or constant speed alternating current motor and speed box. Where



possible to use a direct current motor with a variable speed range of three to one this drive is considered preferable by the manufacturer.

### BAND SAW FOR CUTTING METAL

A metal band saw has recently been developed by H. C. Williamson, 1840 West Lake street, Chicago, which is adapted to a wide range of cutting-off operations. It will cut off any size stock up to 10 in. in diameter and is shown in the illustration with a 12 in. I-beam in position, which, it is claimed, it will handle without difficulty.

The table is 20 in. high and a number of holes are drilled and tapped in the surface for use in attaching clamps to special work. It has been kept as low as possible in order to facilitate the handling of heavy pieces. For handling bars or tubes the table is equipped with a back and vise jaw by means of which the work is readily clamped in position. A swivel back and vise is also furnished for cutting at any angle.

The saw is carried by flanged pulleys which are attached to a swinging frame back of the table. This frame is pivoted about the driving shaft at the base of the machine. The saw is driven by a 24-tooth pinion on the driving shaft, which meshes with a 96-tooth bevel gear, the rim of which forms the lower pulley about which the saw passes. The arrangement of pulleys is such that the saw returns at the rear of the table, thus making it possible to handle stock of any

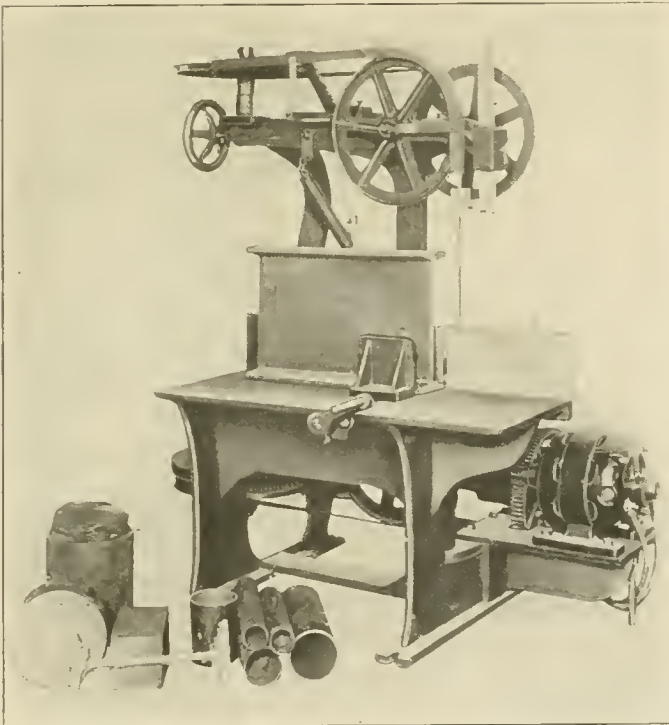

Motor Driven Metal Cutting Band Saw

length. A handwheel adjustment is provided at the top of the swinging frame by means of which the tension on the saw is regulated. In operating the machine after the work has been clamped to the table the swinging frame is tilted forward by means of a handle at the top until the saw begins to cut; it then feeds by gravity without further attention from the operator. An automatic stop is provided by means of which the power is shut off when the saw has finished cutting.

It is claimed that in cutting off tubes, which cause considerable trouble by breaking the teeth when a hack saw is

used, the band saw causes little trouble because of its continuous motion and uniform feed. The time required to cut off a 5 in. superheater tube is claimed to be two minutes, while a 3 in. round bar requires seven minutes, this time being slightly increased as the saw becomes dull. The operation of this machine requires about  $\frac{1}{2}$  h. p.

### PORTABLE STEAM OR AIR HOIST

A small hoist which has a lifting capacity of 1,000 lb. has recently been brought out by the Ingersoll-Rand Company, 11 Broadway, New York City. Due to its light weight, which is under 300 lb. complete, it is particularly suitable for light lifting service wherever a portable hoist is required. In

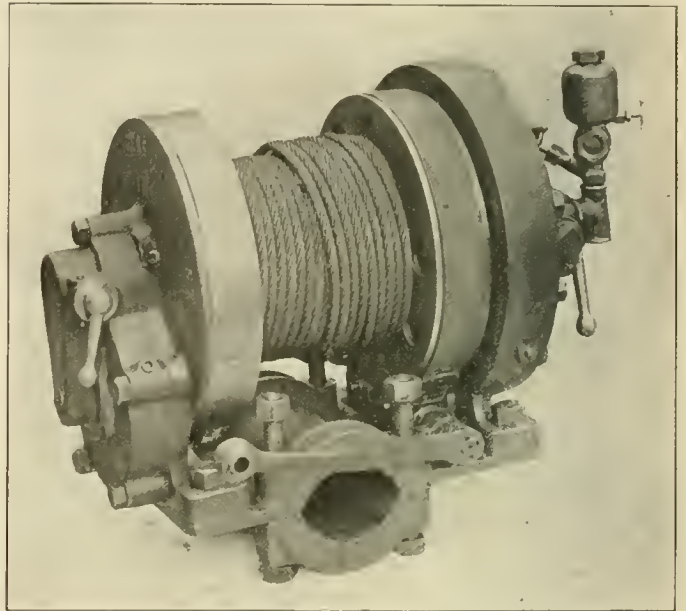

Portable Hoist for Attachment to a Column or a Timber Foundation

manufacturing and power plants it is very handy for moving light machinery, for hoisting ashes and other waste material, for loading trucks, etc. It is particularly suited for service in foundries in lifting flasks and ladles. In ship yards, railroad shops and on construction work it can be put to a variety of uses.

The base is arranged so that it may be bolted to a timber foundation or clamped to a circular member such as a column, shaft bar or pipe, to which it may be quickly attached. The dimensions of the hoist are  $21\frac{1}{4}$  in. by  $16\frac{1}{2}$  in., the height being  $20\frac{1}{8}$  in. The drum is 6 in. in diameter with a space between flanges of 7 in. This will accommodate 700 ft. of  $\frac{1}{4}$  in. rope or 450 ft. of  $\frac{5}{16}$  in. rope. The capacity of 1,000 lb. is obtained at a rope speed of 85 ft. per minute and a steam or air pressure of 80 lb. per sq. in.

The motor is of the reversible square piston type giving four impulses per revolution of the engine. There are no dead centers and the hoist will start in any position. The drum is mounted independent of the motor shaft and is operated through a clutch and gears. Safety is provided by a powerful worm-operated band brake lined with Raybestos. The front of the hoist is shown in the illustration. The motor is on the right hand side adjacent to which is the band brake. The gear case is on the left hand side, the gears and clutch being controlled by the lever shown on the gear case. The throttle lever at the right controls both the speed and direction of operation and when released it returns automatically to the central position, thus shutting off the power

and stopping the hoist. The brake is operated by the long lever shown at the bottom.

All moving parts with the exception of the drum are enclosed, thus insuring against accidents to workmen who would otherwise be in constant danger of catching their clothing in the gears.

### PIPE BENDING MACHINE

The frequent demand for a machine to bend large pipe has led to the development by the Pedrick Tool & Machine Company, Philadelphia, Pa., of the machine shown in the illustration. This is similar in construction to those designed by the same company for pipes of small size, some modifications being made to secure the increased strength required. The main frame is a rectangular casting ribbed on one side and provided with large bosses where the gear shaft passes through. The gears are machine cut, of heavy pitch, and have wide faces. The ratio is ample to permit the use of hand power. One end of the pipe to be bent is clamped in position at the end of a quadrant of

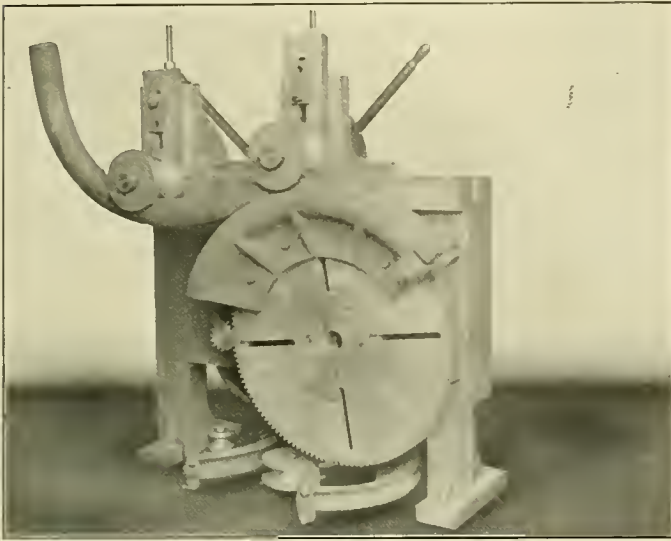

Machine for Bending Large Pipe

the desired radius, which is attached to the face plate. Two rollers which are adjustable both laterally and vertically are secured to the frame of the machine. These may be brought to bear on the pipe at any desired points.

It is claimed that with this machine two men can easily put right angle bends in pipe 4 in. in diameter, the work being done with the pipe cold and unfilled. The illustration shows a 4 in. pipe in the machine bent on an 18½ in. radius, which is smaller than usually called for in practice. The bends made by this machine are smooth and round, and are claimed to be satisfactory in every way.

**DUNTLEY ELECTRIC DRILL USED ON RADIAL DRILL.**—The Chicago Pneumatic Tool Company, Chicago, reports a new application of its Duntley electric drill. It is provided with a Morse taper shank so that it may be used in an ordinary radial drill, and will be of particular value when it is necessary to drill small holes in large castings that also require large holes. Instead of using the radial drill and running it at a high speed for the small drills the electric drill may be inserted in the spindle of the machine and operated under its own power, thereby saving the wear and tear on the more expensive machine. Both the longitudinal and vertical feed of the radial drill may be used to advantage in spotting and drilling the holes with the small electric drill.

### MONORAIL SYSTEM WITH FIXED TONGUE TRACK SWITCHES

A wider application of the overhead monorail system to the requirements of inter-shop transportation, coal and ash handling and similar service has been brought about by the recent development of an electric monorail system with fixed tongue track switches, which has been made by the Shaw Electric Crane Company, Muskegon, Mich. A typical two-motor monorail hoist of this type is shown in one of the illustrations.

The ordinary form of monorail track switch is a hinged section of the runway girder, engaging the main and spur tracks, and the limitations inherent in this switch tend to restrict the application of the overhead monorail system. The distinctive feature of the Shaw Monorail System is the absence of any moving part in the track switch, which somewhat resembles a

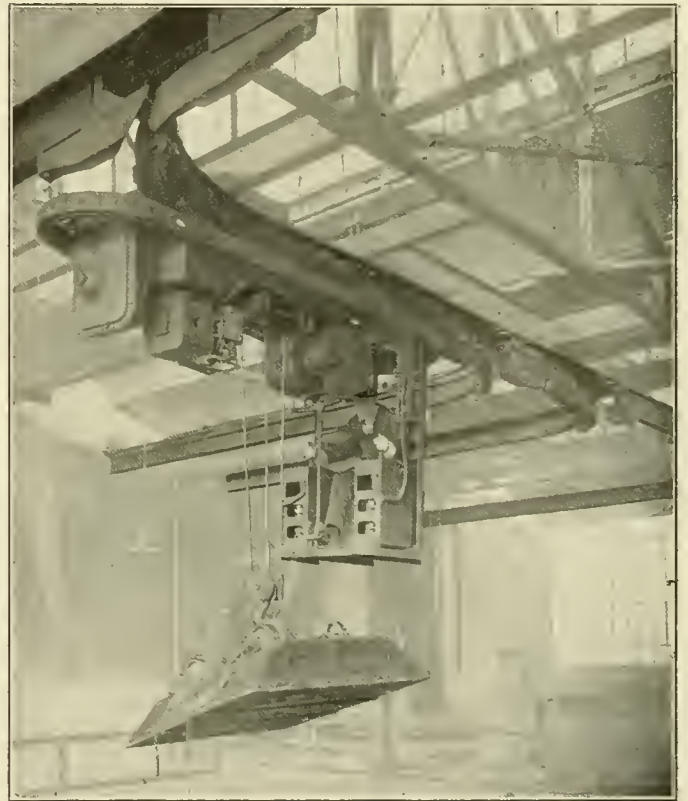

Fig. 1—Two-Motor Monorail Hoist Operating on Track System with Fixed Tongue Switches

frog in appearance and operation. The operator in the cab has independent and absolute control, both of the route and the hoisting and travel operations. The hoist may be run through the switches in all directions without stopping, the operator selecting his route while in motion. There are no open ends of the track to be protected, and it is therefore impossible for the trolley to break through and fall to the ground. The illustration of the cast-steel track switch, Fig. 2, shows clearly the two slots through which the truck sides pass, the left side through slot A when the trucks run through the switch, and the right side through slot B when diverted to the spur track. In either case the truck wheels run over the gaps, but the wheel-base of the truck is so proportioned that three wheels always ride on the runway flanges, and the wheels bridge the gaps at such an angle that the break is only nominal.

The manner in which the leading truck is steered onto the spur track is shown in Fig. 3, which is a sectional plan at the level of the lower flanges of the I-beam track, showing a right hand switch and the truck sides of the trolley. When approach-



ing the track switch with the intention of running onto the spur, the horizontal roller  $T_2$  located in the front of the leading truck, is raised by the steering lever in the cage and engages the curved flange  $S$  on the underside of the central tongue of the switch. The advance end of the flange is shown in the illustration of the switch, Fig. 2.

In this manner the leading truck is swiveled and diverted to the spur track. No steering operation is necessary to return from the spur to the main track nor to run through the track switch in either direction on the main line.

The method by which the trailing truck is compelled to follow so that the trolley cannot split the switch, is shown in Fig. 4. The smaller diagram is an enlarged sectional plan showing the rear

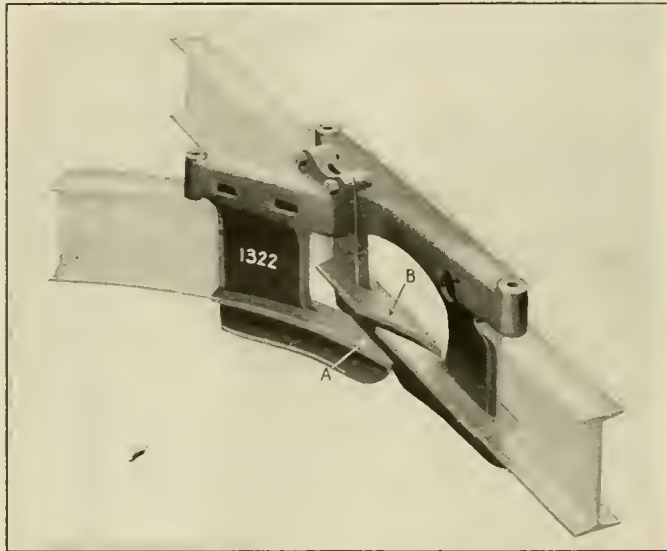

Fig. 2—Cast Stéel Track Switch

truck frame and a portion of the trolley frame which joins the two trucks and supports the hoisting machinery, taken at the level of the trolley frame. Lines  $L$ ,  $R$  and  $F$  represent the center lines respectively of the leading truck, the rear truck and the trolley frame. The trucks swivel on the trolley frame through angle  $A$ , which is limited by an adjustable set screw  $S_1$  in truck side  $R_1$ .

Assuming both trucks to be on the main track and approaching the switch, center lines  $L$ ,  $R$  and  $F$  then lie in the same vertical plane and the angle  $A$  is zero. As the leading truck proceeds around the curve of the spur, the trolley frame swings around with reference to the center line  $R$  of the rear truck, and the angle  $A$  increases. When the rear truck reaches the point where the curve begins, as shown in the engraving, the

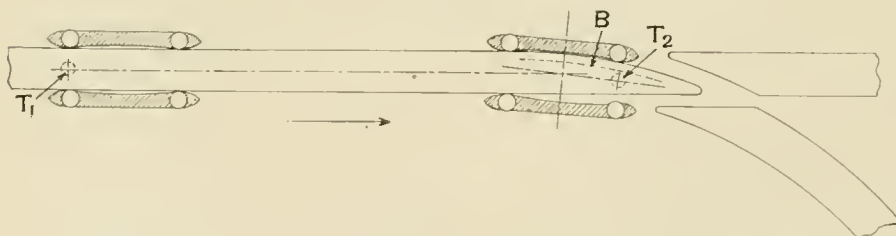

Fig. 3—Section Through Truck Side Frames at the Lower Flange of the Track I-Beam, Showing a Right-Hand Switch

set screw  $S_1$  engages the frame casting and angle  $A$  has attained its maximum value; as the trolley proceeds beyond the position shown, the frame casting slews the rear truck around and compels it to follow to the spur track. It should be noted that this operation is automatic, and entirely independent of the initial steering operation. The only essential condition is that all curves on the same track system have the same radius for a

length of arc whose chord is the center line  $F$ , as this arc determines the angle  $A$  for which the set screw  $S_1$  is adjusted; beyond this arc any longer radius may be employed. Set screw  $S_2$  in the truck side  $R_2$  provides for similar operation on left hand switches. Both trucks embody the steering feature and the

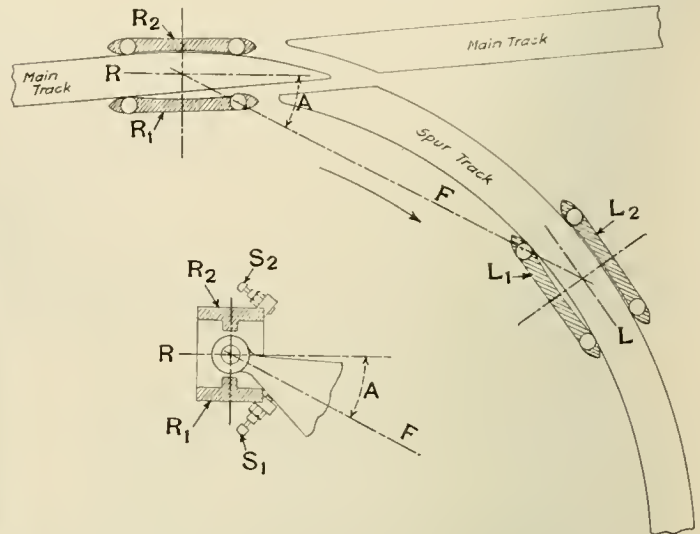

Fig. 4—Means by which the Rear Truck is Automatically Compelled to Follow Through the Switch

set screw adjustment, so that operation in both directions is identical.

Several installations of this monorail system are reported to be in successful operation, the capacities ranging from two to six tons. The hoist is built either with the single lift as shown, or with a double hoist for handling the ordinary two-line clamshell bucket, two separated holding lines being employed to prevent swiveling of the bucket.

## A PROCESS OF CASEHARDENING WITH GAS

A process of casehardening in which gas is used as the carbonizing agent has recently been developed by the American Gas Furnace Company, 24 John street, New York. The process is performed in a slowly revolving cylindrical retort into which the carbonizing gas is injected under pressure. From this gas the work absorbs volatile carbon, arrangements being provided for venting the waste gas as required to insure a maximum speed of carbon penetration.

The drawing shows a longitudinal sectional elevation of a gas



carbonizing furnace. The heavy wrought iron retort  $A$  is surrounded by a cylindrical furnace body, within which it is rotated on rollers attached to the ends of the furnace. The work is confined within the retort between two pistons, large air spaces being provided between the pistons and the ends of the retort. The carbonizing gas is admitted through one piston and the waste gas vented through the other.

A complete plant consisting of a carbon gas producer and two furnaces is shown in the illustration. The furnaces are supported by trunnions; and the pipe connections to the furnace and retort, together with the chain and sprockets by means of which the retort is revolved, are so arranged that the furnace may be tilted for convenience in filling and emptying without disconnecting the pipes or the driving mechanism.

The generator supplies gas made up of carbon vapor derived

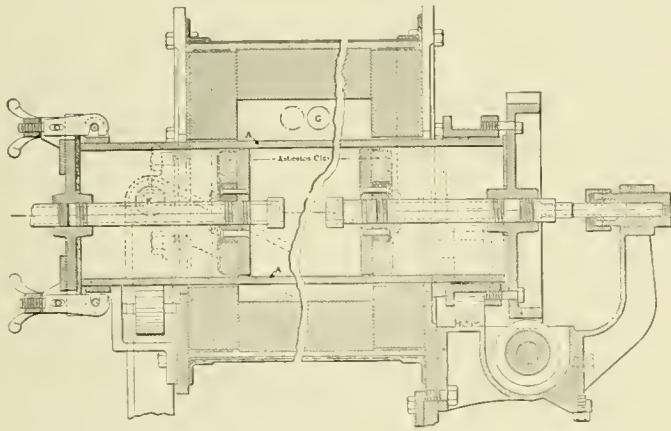

Sectional View Through Carbonizing Furnace

from refined petroleum and a neutral gas, combined in such proportions that the absorption of carbon by the work will take place without the formation of obstructing carbon deposits. Each generator has a capacity sufficient to supply two machines of the type illustrated. In many cases it is possible to use ordinary illuminating gas as the carbonizing agent, thus dispensing with

length of time than work near the center. Volatile carbon finds its way into slots, holes and cavities into which sufficient solid material to produce the desired penetration could not be packed. There is also a saving in time due to the shorter period required to heat the volatile carbon retort to the temperature at which carbon is absorbed.

Each machine of the size shown in the illustration is claimed to require for fuel 400 cu. ft. of illuminating gas, or its heating equivalent, per hour, carbonizing gas being furnished at a cost of about 10 cents per hour. The retort requires renewal at a cost of \$48 after a service of about 400 hours.

### SERVICE RECORDS OF CHROME-VANADIUM ROLLED STEEL TENDER WHEELS

In order that the relative merits of various types of tender wheels might be definitely determined, three successive lots of Mikados purchased by the Grand Trunk during the past year and a half have each been equipped with different types. The tenders of these engines have a capacity of 9,000 gal. of water and 15 tons of coal; they have a total weight in working order of 172,100 lb., and a load per wheel at the rail of 21,525 lb. There were 25 engines in each lot, the tenders of the first lot being equipped with untreated carbon steel tired wheels, the second lot with oil treated rolled wheels of carbon steel, and the third lot with oil treated rolled wheels of chrome-vanadium steel. Both the rolled wheels of carbon and chrome-vanadium steel were made by the Standard Steel Works Company. One of the serious problems of locomotive maintenance with which the Grand Trunk has to contend is the large amount of shelling of wheels and tires during the severe cold of the winter months. The

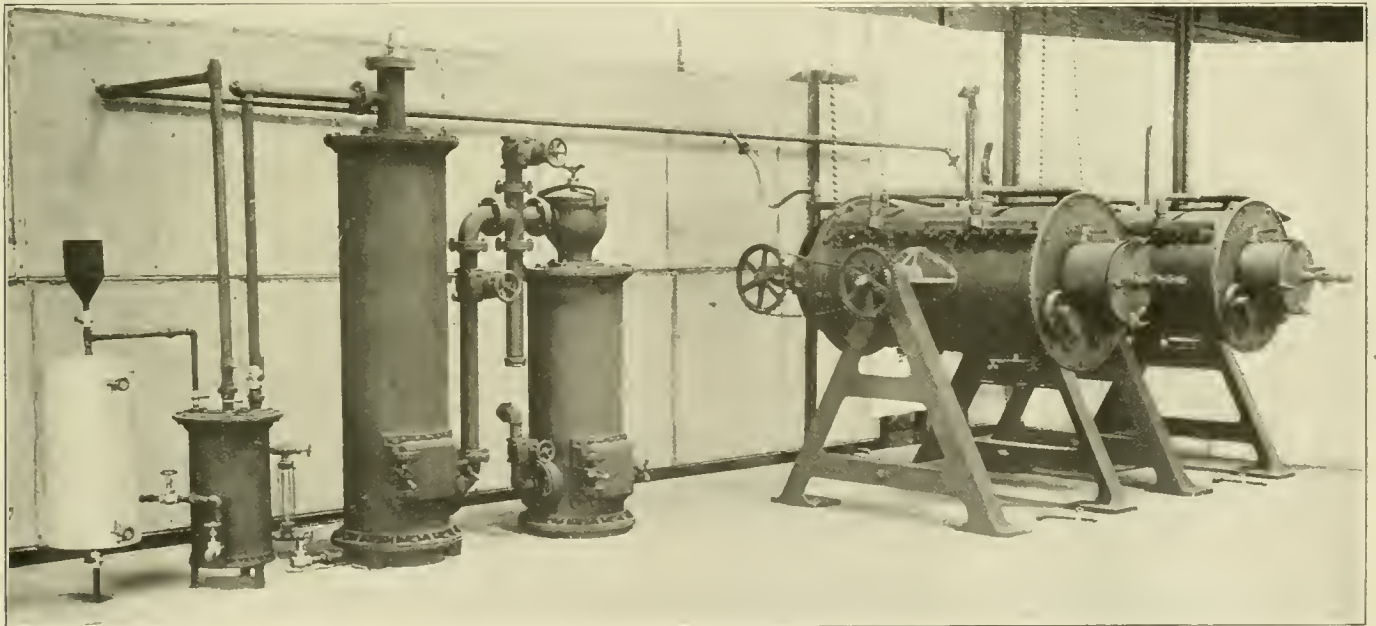

Complete Carbonizing Plant, Made Up of Gas Producer and Two Furnaces

the generator. Whether or not this can be done depends upon the gas available, which must be low in sulphur.

By the use of gas the process of carbonizing may be performed with much greater uniformity than is possible where the work is packed in solid carbon. All parts of each piece and all pieces included in a charge are subjected to exactly the same treatment, thus assuring uniformity in the depth of penetration. Owing to the low heat conductivity of the various solid materials used as carbonizing agents, work near the outside of the retort will be subjected to the carbonizing temperature for a greater

conditions under which the test was conducted afforded an opportunity to make a thorough comparison of the advantages of the three types of wheels in this respect. The steel tired wheels entered service during a period from late in January to the early part of March, 1913. The oiled treated carbon steel wheels entered service in August and September, 1913, and the vanadium steel wheels during November of the same year. Although the steel tired wheels were in service during a longer period than either of the two types of rolled wheels they saw little service during the winter of 1913, and their service during the severe



cold of the past winter is considered as the real test of their ability to withstand shelling. All cases of shelling on these wheels occurred during the past winter.

The records from the date the first lot of Mikados entered service, until May 1, 1914, show that during this period three pairs, or 3 per cent of the chrome-vanadium steel wheels had been removed on account of shelling, while nine pairs, or 9 per cent of carbon steel wheels and 17 pairs, or 17 per cent of the steel tired wheels had been removed from the same cause. Further comparison showed that a total of 8 per cent of the vanadium steel wheels, 22 per cent of the carbon steel wheels and 52 per cent of the steel tired wheels had to be removed from all causes, including sharp flanges and tread wear. Owing

to the longer service of the steel tired wheels, however, which accounts for the larger number of renewals due to tread and flange wear, no comparison is justified except as to the shelling out of the treads.

### HYDRAULIC BUSHING PRESS

The hydraulic press shown in the illustration is designed especially for use in railroad shops for pressing on and off bushings and is built by R. D. Wood & Company, Philadelphia, Pa. It is operated by a belt driven double plunger pump and is equipped with a release valve, safety valve and pressure gage. The pump valve is made of a solid steel forging which is bored out and fitted with bronze valves and

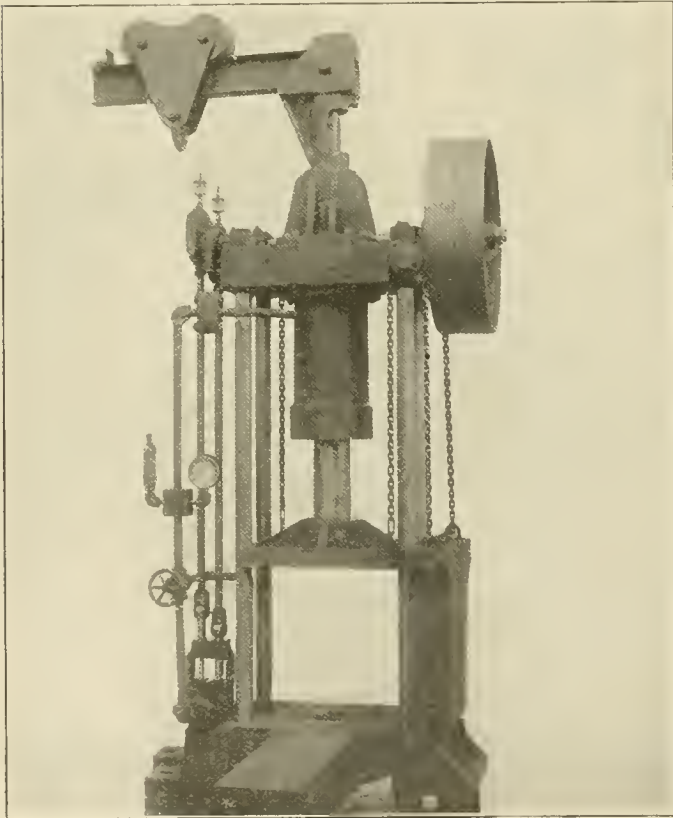

Hydraulic Bushing Press with Capacities Up to 150 Tons

seats. The press cylinder is made of open hearth steel and is fitted with a semi-steel ram provided with cupped leather packing. The ram is counterbalanced and is guided by the four columns which form the frame of the press. At the top of the press is a short crane, shown in the illustration, which is provided with a trolley for handling heavy work. This is not regularly provided, but can be furnished if ordered.

Presses of this type are built in capacities ranging from 30 tons to 150 tons. The diameter and stroke of the ram for

the various capacities range from 6 in. by 14 in. to 9 in. by 24 in. This press has been developed to meet the demand for increased capacity and a number have been installed with a capacity of 100 tons for handling bushings, crown brasses and similar work.

### ELECTRIC LATHE CENTER GRINDER

The usual method followed in truing up lathe centers is to grind the center while revolving in the spindle, by means of a tool post grinder mounted upon the carriage of the lathe. After having secured the axis of the grinder at the proper angle with the axis of the lathe spindle it usually requires several trials before an adjustment of the grinder is secured in which its spindle and the lathe spindle are brought into the same plane. Until this adjustment is secured the spindle cannot be ground accurately to a 60 deg. angle, but will have a curved surface.

The portable electric grinder shown in the illustration has been developed by the Neil & Smith Electric Tool Company,

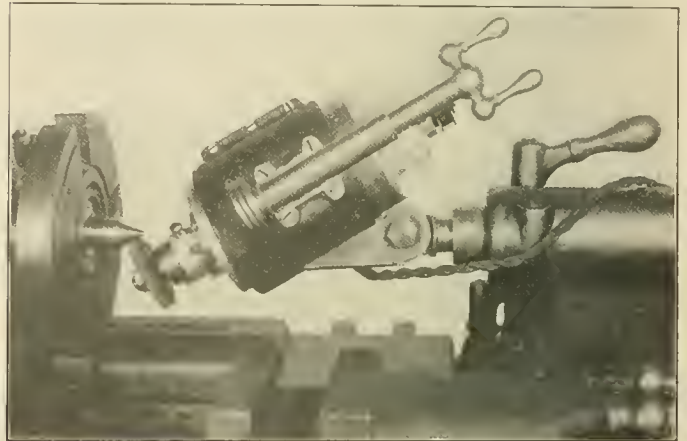

Grinder Centered in the Tailstock of a Lathe

Cincinnati, Ohio, to overcome the difficulties arising from the necessity of this adjustment. Instead of attaching this grinder to the tool post it is supplied with a taper shank which is inserted in the tailstock of the lathe in place of the regular dead center. Since the axis of the spindle in the grinder and the axis of the taper shank intersect, the grinder is at once in the proper position to grind a 60 deg. angle on the center in the headstock and no adjustment is required by the operator. In order that the grinder may be interchangeable on different size lathes a number of taper shanks are furnished, corresponding to the various size groups of lathes, all of which are secured to the grinder by a standard shank fitted to the grinder body. The grinder weighs about 18 lb. and is designed for operation on a 110 volt circuit at a speed of about 6,000 revolutions per minute.

**MAKING TRACINGS WITHOUT INK.**—A drafting fabric has been put on the market by the Universal Drafting Machine Company, Cleveland, Ohio, to permit of making blue prints from original drawings without requiring the use of ink or pencil. The fabric is a cloth covered with a thin skin of hard brown material, and drawings are traced on it by means of a beveled steel point or scriber. Corrections may be made by means of an ordinary steel pen and ink. Lines may then be drawn through the corrections. It is also easy to change a full line to a dotted line by filling in the spaces with ink. The steel point used may be inserted in a compass when it is required to do circular work. Blue prints made in the ordinary way give, of course, dark lines on a white ground.—*The Iron Age*

# NEWS DEPARTMENT

On Sunday, August 16, according to a press despatch, the sum of \$25,000 was taken in by the government in the shape of tolls for the passage of vessels through the Panama Canal.

A standard dining car of the Chicago, Burlington & Quincy has been selected by the state pure food commissioner of Nebraska to demonstrate the proper method of serving food on dining cars, at the state fair to be held in Lincoln, September 7 to 11. All meals will be served to the fair visitors, who will be allowed to inspect the kitchen and see how the work is conducted.

The monorail street car line which was built in the northern part of New York City a few years ago appears, after many vicissitudes, at last to be dead. A new line of ordinary street cars, with storage battery motive power, was put in service August 18. The line is from the City Island station of the New York, New Haven & Hartford Railroad to Belden's Point, about 3 miles. The opening of the line followed the condemnation of the monorail as unsafe a few months ago.

The safety bureau of the El Paso & Southwestern has issued a circular showing the behavior of 3,607 automobiles and their drivers observed during the period of one week while crossing the tracks of the road in El Paso. It was found that 2,907, or 80 per cent of the drivers of these automobiles, did not look in either direction; 620, or 17 per cent looked only in one direction, and only 80, or 2 per cent, took the precaution to look both ways before crossing the tracks; while 296 of the number who looked in neither direction crossed at a speed greater than 20 miles an hour. And six of this number saw the flagman and crossed the tracks disregarding his signal.

In a paper on the Compound Articulated Locomotive, presented by Anatole Mallet, originator of the Mallet type of locomotive, before the Institution of Mechanical Engineers at the Paris meeting, held in July, a method of comparing the weight of locomotives with the weight of rail was mentioned. Mr. Mallet showed that in 1829, engines weighing five tons ran on rails of 34.2 lb. per yard, which was equal to 327 times the weight of rail per yard. In 1846, engines weighing 22 tons ran on rails of 70.52 lb. per yard, which is 700 times the weight of rail per yard. In 1880, 56-ton engines ran on rails of 84.6 lb. per yard, which is 1,480 times the weight of rail per yard. In 1911, engines weighing 96 tons ran on 96.77 lb. rails, which is 2,220 times the weight of rail per yard, and in the United States a Mallet engine with 10 coupled axles weighing 245 tons, adhesive weight, ran on 111 lb. rails, which is 4,950 times the weight of rail per yard.

## SAFETY-FIRST PLACARDS

The Southern Pacific is posting in conspicuous places along its lines large placards displaying the following:

"We solicit your co-operation in preventing death and injury to yourself, our patrons and the community at large. Stop to look and listen before passing over railway grade crossings. Refrain from and discourage trespassing upon railroad property. Be careful when waiting for trains or using the company's facilities.

"It is not safe to start over a railway crossing without first stopping to look and listen, to get on or off trains while in motion to stand near edge of platform when trains are passing, to cross over ahead of an approaching train, or pass closely behind a train standing, to stand or walk upon tracks around stations or elsewhere, to allow children to play around the station,

tracks and cars." Then follow some figures regarding trespassing and grade crossing accidents.

## LOCOMOTIVE SMOKE IN CHICAGO

The method of controlling locomotive smoke in Chicago under the direction of the General Managers' Association has been referred to several times in these columns. That this arrangement has proved very successful is shown by the biennial returns made by the department of smoke inspection of the city. This summer's returns, including 9,453 observations, shows the best record for summer reading since the department was established. This year the average density is 6.304, as compared with 11.99 last summer. While the latest average is larger than that shown in the autumn of 1913 (5.79), it must be remembered that usually a great deal more smoke will be shown in the warm weather than in cold.

Out of seven reports this is the sixth in which the Chicago, Burlington & Quincy has maintained first place. The Burlington certainly is to be congratulated on the success it has attained, especially when it is considered that this road has a very large number of locomotives operating in the city. J. H. Lewis is chief inspector for the Burlington and also chairman of the Railroad Smoke Inspectors' Association, which reports to the General Managers' Association.

The roads in Chicago maintain 50 smoke inspectors, at a cost of about \$65,000 per year in salaries, to keep locomotive smoke to a minimum. That this expenditure is warranted is shown by the smoke returns for the summer of 1914, as follows:

Railroad	Density, Summer, 1914	Density, Summer, 1913	Standing, Summer, 1913	Density, Autumn, 1913	Standing, Autumn, 1913
1—C. B. & Q.....	1.63	7.74	5	1.64	1
2—Santa Fe.....	3.04	4.73	1	2.45	3
3—Northwestern.....	3.25	7.65	4	2.25	2
4—Lake Shore.....	3.75	9.49	6	2.76	4
5—Soo Line.....	3.94	10.86	7	13.54	27
6—C. G. W.....	4.3	13.37	12	3.99	6
7—Mich. Cent.....	4.39	12.23	11	6.32	13
8—Grand Trunk.....	4.68	16.62	23	4.89	9
9—St. Paul.....	4.81	11.75	8	3.64	5
10—Pennsylvania.....	5.15	16.58	22	7.89	22
11—C. & W. I.....	5.32	17.1	25	6.61	15
12—C. & O.....	5.5	14.78	17	4.	8
13—Illinois Cent.....	5.5	7.43	3	3.99	7
14—B. & O. C. T.....	6.14	12.14	10	7.23	21
15—N. Y. C. & St. L.....	7.11	11.9	9	6.42	14
16—Rock Island.....	7.24	14.66	15	5.16	10
17—C. & E. I.....	7.87	14.73	16	6.92	17
18—C. I. & S.....	8.66	15.12	19	5.29	11
19—Wabash.....	9.81	14.12	14	7.19	19
20—C. & A.....	11.31	16.56	21	6.84	16
21—Ill. Northern.....	11.54	6.31	2	6.03	12
22—Pere Marquette.....	12.04	18.8	28	7.19	20
23—B. & O.....	12.12	13.4	13	12.41	25
24—Monon.....	12.21	15.63	20	7.15	18
25—Belt.....	12.26	18.06	26	9.27	23
26—E. J. & E.....	12.77	18.45	27	11.91	24
27—Erie.....	15.71	20.51	29	12.57	26
28—C. Junction.....	18.1	17.01	24	19.29	28
29—Pullman.....	26.49	Not listed		48.42	31
30—C. R. & I.....	35.	14.94	18	41.46	30
31—C. Short Line.....	45.45	29.23	32	34.	29

## PRIZES FOR AIR BRAKE STORIES

The sum of \$2,000 in prizes has been offered by the Westinghouse Air Brake Company in several advertisements published in various technical papers during the last few months. The company stated that it would pay this sum for the six best stories submitted, under certain conditions, dealing with the experience and practical knowledge of railroad employees regarding any striking performance of the air brake manufactured by this



company. The history of braking railroad trains is full and complete in dramatic but unwritten narrative, and the company believes that by offering this incentive a vast amount of this material will be brought to light. The conditions stated that the story must be written either from the practical experience or the personal observation of the writer, or from information obtained first hand from railroad men who actually knew the facts related. The contest closed August 1, 1914, and the committee of judges, composed of the following men, is now engaged in judging the entries: W. E. Symons, consulting mechanical engineer, Chicago; Willard Smith, editor, Railway Review, Chicago; and Roy V. Wright, managing editor, Railway Age Gazette, New York City. Considerable interest was displayed in the contest, and a large number of stories submitted so that several weeks will elapse before the judges will be able to announce the winners of the prizes.

**TOOL FOREMEN'S CONVENTION**

In the remarks of E. J. McKernan, supervisor of tools of the Atchison, Topeka & Santa Fe at the Tool Foremen's convention, an abstract of which was published on page 425 of the August issue, the taper of 3 in. in 12 in. given for the reamer for the Stephenson valve gear should have been 3/8 in. in 12 in.

**A CORRECTION**

On page 315 of the June, 1914, issue the reference in the paragraph near the bottom of the last column to the voltage used in electric welding outfits should have been to current, in amperes; and on page 318 in the reference to radial stays, the taper of 3/4 in. in 1 1/2 in. should have been 1/4 in.

**MEETINGS AND CONVENTIONS**

*Master Car and Locomotive Painters' Association.*—The forty-fifth annual convention of the Master Car and Locomotive Painters' Association will be held at the Hotel Hermitage, Nashville, Tenn., September 8 to 11, inclusive. The subjects to be considered are: Finishing Steel Passenger Equipment; Rust Inhibitive Paint for Steel Freight Cars; Shop Practice in Finishing New Interior Wood Finish of Passenger Coaches; Locomotive Tender Varnishes; Classification of Interior and Exterior Repairs of Passenger Cars; Apprentice System in the Paint Shop; Results of the Sand Blast as a Paint Remover; Standard Freight Car Lettering, and Blister-proof Paint for Locomotives. A. P. Dane, Reading, Mass., is secretary.

*American Foundrymen's Association and American Institute of Metals.*—The American Foundrymen's Association and the American Institute of Metals will hold their annual conventions at the LaSalle hotel, Chicago, September 7-11. In connection with these conventions the Foundry & Machine Exhibition Company will conduct its annual exhibit from September 5 to 11, inclusive, at the International Amphitheater located at the Stock Yards in Chicago. This exhibit will include many articles of interest to railroad men. A review of the list of the 164 exhibitors discloses the fact that 50 per cent of them handle railway supplies. About forty of these are prominent builders of modern machine

tools that are in every-day use in railway shops. Others represent shop accessories, such as pneumatic tools, grinding machines and abrasives, cranes, hoists and other shop fixtures that are no less important. The oxy-acetylene and electric welding companies will be represented with working demonstrations of their systems as will also the Goldschmidt Thermit Company. Railway men who can take the time to attend this exhibit will find it very well spent.

*Traveling Engineers' Association.*—The twenty-second annual convention will be held at the Hotel Sherman, Chicago, Ill., commencing at 10 a. m., Tuesday, September 15, and continuing four days. The subjects to be discussed are as follows: Difficulties accompanying prevention of dense black smoke and its relation to cost of fuel and locomotive repairs; Martin Whalen, chairman. Operation of all locomotives with a view of obtaining maximum efficiency at lowest cost; J. R. Scott, chairman. Advantage to be derived from the use of mechanical stokers, considering (first) increased efficiency of the locomotive; (second) increasing the possibility of securing a higher type of candidates for the position of firemen; (third) the utilization of cheaper grades of fuel; J. H. DeSalis, chairman. The care of locomotive brake equipment on line of road and at terminals; also, methods of locating and reporting defects; Geo. H. Wood, chairman. Advantage derived from the use of speed recorders and their influence on operating expense; Fred Kerby, chairman. Practical chemistry of combustion; A. G. Kinyon. Scientific train loading; tonnage rating; the best method to obtain maximum tonnage haul for the engine over the entire division, taking into consideration the grades at different points on the division; O. S. Beyer, Jr.

*The following list gives names of secretaries, dates of next or regular meetings, and places of meeting of mechanical associations.*

- AIR BRAKE ASSOCIATION.—F. M. Nellis, 53 State St., Boston, Mass. Convention, May 5-7, 1915, Hotel Sherman, Chicago.
- AMERICAN RAILWAY MASTER MECHANICS' ASSOC.—J. W. Taylor, Karpen building, Chicago.
- AMERICAN RAILWAY TOOL FOREMEN'S ASSOCIATION.—Owen D. Kinsey, Illinois Central, Chicago. Convention, July, 1915, Chicago.
- AMERICAN SOCIETY FOR TESTING MATERIALS.—Prof. E. Marburg, University of Pennsylvania, Philadelphia, Pa.
- AMERICAN SOCIETY OF MECHANICAL ENGINEERS.—Calvin W. Rice, 29 W. Thirty-ninth St., New York. Convention, December 1-4, 1914, New York.
- CAR FOREMEN'S ASSOCIATION OF CHICAGO.—Aaron Kline, 841 North Fifth St. Court, Chicago; 2d Monday in month, except July and August, Lytton building, Chicago.
- CHIEF INTERCHANGE CAR INSPECTORS' AND CAR FOREMEN'S ASSOCIATION.—S. Skidmore, 946 Richmond street, Cincinnati, Ohio.
- INTERNATIONAL RAILWAY FUEL ASSOCIATION.—C. G. Hall, 922 McCormick building, Chicago. Convention, May 17-20, 1915, Chicago.
- INTERNATIONAL RAILWAY GENERAL FOREMEN'S ASSOCIATION.—William Hall, 914 W. Broadway, Winona, Minn. Convention, July, 1915.
- INTERNATIONAL RAILROAD MASTER BLACKSMITHS' ASSOCIATION.—A. L. Woodworth, Lima, Ohio.
- MASTER BOILER MAKERS' ASSOCIATION.—Harry D. Vought, 95 Liberty St., New York.
- MASTER CAR BUILDERS' ASSOCIATION.—J. W. Taylor, Karpen building, Chicago.
- MASTER CAR AND LOCOMOTIVE PAINTERS' ASSOC. OF U. S. AND CANADA.—A. P. Dane, B. & M., Reading, Mass. Convention, September 8-11, 1914, Nashville, Tenn.
- NIAGARA FRONTIER CAR MEN'S ASSOCIATION.—E. Frankenberger, 623 Brisbane building, Buffalo, N. Y. Meetings monthly.
- RAILWAY STOREKEEPERS' ASSOCIATION.—J. P. Murphy, Box C, Collinwood, Ohio.
- TRAVELING ENGINEERS' ASSOCIATION.—W. O. Thompson, N. Y. C. & H. R., East Buffalo, N. Y. Convention, September 15, 16, 17 and 18, 1914, Hotel Sherman, Chicago, Ill.

**RAILROAD CLUB MEETINGS**

Club	Next Meeting	Title of Paper	Author	Secretary	Address
Canadian .....	Sept. 8	.....	.....	James Powell.....	Room 13, Windsor Hotel, Montreal.
Central .....	Sept. 11	Brick Arches .....	George Wagstaff.....	H. D. Vought.....	95 Liberty St., New York City.
New England.....	Sept. 8	.....	.....	Wm. Cade, Jr.....	683 Atlantic Ave., Boston, Mass.
New York.....	Sept. 18	Handling Miscellaneous Freight at Boston.	Dr. Harold Perder.....	H. D. Vought.....	95 Liberty St., New York City.
Pittsburgh .....	Sept. 25	Government Regulation of Railway Operation	Samuel O. Dunn.....	J. B. Anderson.....	207 Penn. Station, Pittsburgh, Pa.
Richmond .....	Sept. 14	.....	.....	F. O. Robinson.....	C. & O. Ry., Richmond, Va.
St. Louis.....	Sept. 11	.....	.....	B. W. Frauenthal.....	Union Station, St. Louis, Mo.
Southern & S'w'rn	Sept. 17	.....	.....	A. J. Merrill.....	218 Grant Bldg., Atlanta, Ga.
Western .....	Sept. 15	.....	.....	Jos. W. Taylor.....	1112 Karpen Bldg., Chicago, Ill.

## PERSONALS

*It is our desire to make these columns cover as completely as possible all the changes that take place in the mechanical departments of the railways of this country, and we shall greatly appreciate any assistance that our readers may give us in helping to bring this about.*

### GENERAL

MORGAN K. BARNUM, general mechanical inspector of the Baltimore & Ohio, at Baltimore, Md., has been appointed superintendent of motive power of the Baltimore & Ohio proper, with office at Baltimore. Mr.

Barnum was born on April 6, 1861, and was graduated from Syracuse University in 1884 with the degree of A. B., and later received the degree of A. M. He began railway work in 1884 as a special apprentice in the shops of the New York, Lake Erie & Western, now the Erie, at Susquehanna, Pa. He was then consecutively machinist and mechanical inspector, and later general foreman of the same road at Salamanca, N. Y.; general foreman of the Louisville & Nashville shops at New Decatur, Ala.; assistant master mechanic



M. K. Barnum

of the Atchison, Topeka & Santa Fe, at Argentine, Kan.; superintendent of shops at Cheyenne, Wyo.; district foreman at North Platte, Neb., and then division master mechanic at Omaha, Neb., on the Union Pacific; assistant mechanical superintendent of the Southern Railway. In February, 1903, he was made superintendent of motive power of the Chicago, Rock Island & Pacific, and in April of the following year was appointed mechanical expert of the Chicago, Burlington & Quincy; in 1907 he was appointed general inspector of machinery and equipment of the same road. He left that road in April, 1910, to become general superintendent of motive power of the Illinois Central and the Yazoo & Mississippi Valley, remaining in that position until July 1, 1913, when he became general mechanical inspector of the Baltimore & Ohio, and now becomes superintendent of motive power of the same road. He was president of the Master Car Builders' Association in 1913-14.

JOSEPH BILLINGHAM has been appointed superintendent of motive power of the Grand Trunk Pacific at Transcona, Man., succeeding G. W. Robb, resigned.

R. C. EARLYWINE has been appointed assistant air brake instructor of the second and third districts of the Chicago, Rock Island & Pacific at El Reno, Okla.

J. E. EPLER, assistant to the general manager of the Chicago & Eastern Illinois, has been appointed superintendent of motive power, with headquarters at Danville, Ill., to succeed J. H. Tinker, resigned, and the former office is abolished.

W. S. MOSELEY has been appointed mechanical engineer of the Carolina, Clinchfield & Ohio, with headquarters at Erwin, Tenn. He was born on March 5, 1880, at Bonsack, Va., and was educated in the public schools and at Virginia Polytechnic Institute, Blacksburg, Va. He began railway work as a messenger boy in the auditor's office of the Norfolk & Western, and from June, 1894, to January, 1899, was messenger and clerk in the same office.

He was then for three years machinist apprentice in the Norfolk & Western shops and drawing office at Roanoke, Va., and from January, 1902, to January, 1909, was draftsman in the mechanical engineer's office of the same road, with the exception of two years, during which time he was an assistant shop instructor and special student at the Virginia Polytechnic Institute. In January, 1909, he was appointed mechanical draftsman of the Carolina, Clinchfield & Ohio, which position he held at the time of his recent appointment as mechanical engineer of the same road as above noted.

H. E. REYNOLDS has been appointed assistant air brake instructor of the first district of the Chicago, Rock Island & Pacific at Des Moines, Ia.

### MASTER MECHANICS AND ROAD FOREMEN OF ENGINES

WILLIAM O'BRIEN has been appointed master mechanic of the Springfield division of the Illinois Central at Clinton, Ill., succeeding Fred M. Baumgardner, resigned to accept a position with the Interstate Commerce Commission, division of valuation.

W. D. DEVENY has been appointed division master mechanic of the Arkansas River and Colorado divisions of the Atchison, Topeka & Santa Fe at La Junta, Colo., succeeding Hugh Gallagher.

G. GLASFORD has been appointed district master mechanic of the Canadian Pacific at Cranbrook, B. C.

T. C. HUDSON has been appointed master mechanic of the Quebec Grand division of the Canadian Northern at Joliette, Que.

A. J. IRONSIDES has been appointed district master mechanic of the Canadian Pacific at Edmonton, Alta.

JOHN KERR has been appointed road foreman of engines of the Canadian Northern at Joliette, Que.

T. R. McLEOD has been appointed master mechanic of the Ontario Grand division of the Canadian Northern, Eastern lines, at Toronto, Ont.

T. S. LOWE has been appointed master mechanic of the Lake St. John division of the Canadian Northern at Limoilou, Que.

W. C. MOORE has been appointed road foreman of engines of the Ottawa division of the Canadian Northern, Eastern lines, at Trenton, Ont.

JOHN A. MARSHALL has been appointed road foreman of engines of the Northern Pacific, at Duluth, Minn.

W. J. RENNIX, district master mechanic of the Canadian Pacific at Cranbrook, B. C., has been transferred in that capacity to Calgary, Alta.

G. F. SHULL has been appointed acting master mechanic of the Carolina, Clinchfield & Ohio at Erwin, Tenn., succeeding H. F. Staley, master mechanic, resigned.

### CAR DEPARTMENT

J. HODGSON has been appointed foreman, car department, of the Quebec division of the Canadian Northern at Joliette, Que.

F. GOUGE has been appointed foreman, car department of the Lake St. John division of the Canadian Northern at Limoilou, Que.

H. J. WHITE has been appointed general foreman, car department, of the Quebec Grand division of the Canadian Northern at Joliette, Que.

### SHOP AND ENGINE HOUSE

OTTO BRAUN has been appointed assistant foreman of the Pittsburgh & Lake Erie at McKees Rocks, Pa.

F. E. COOPER has been appointed machine shop foreman of the



Pittsburgh & Lake Erie at McKees Rocks, Pa., succeeding J. R. Radcliffe, resigned.

J. W. FINDLAY has been appointed general foreman of the Canadian Northern at Parry Sound, Ont.

JOSEPH FRITTS has been appointed foreman of the Atchison, Topeka & Santa Fe at Syracuse, Kan., succeeding P. Ragan.

R. H. HALL has been appointed locomotive foreman of the Grand Trunk Pacific at Regina, Sask.

R. A. MILLER has been appointed general foreman of the Ottawa division of the Canadian Northern, Eastern lines, at Trenton, Ont.

#### PURCHASING AND STOREKEEPING

F. B. CALHOUN has been appointed storekeeper of the Pecos division of the Atchison, Topeka & Santa Fe at Vaughn, N. M.

LEROY COOLEY has been appointed general storekeeper of the Central Railroad of New Jersey at Elizabethport, N. J., succeeding C. B. Williams, promoted. Mr. Cooley was born July 19, 1877, at Flemington, N. J., and began railway work in 1899, as a clerk in the office of the superintendent of motive power of the Central Railroad of New Jersey, and has been in the continuous service of that road ever since. He held various positions until September, 1908, when he was appointed chief clerk in the same office.

W. A. DICKINSON has been appointed traveling storekeeper of the Atchison, Topeka & Santa Fe at Topeka, Kan.

G. J. FLEISCH has been appointed general traveling storekeeper of the Atchison, Topeka & Santa Fe at Topeka, Kan.

W. G. PHELPS, who has been appointed purchasing agent of the Pennsylvania Lines West of Pittsburgh, with headquarters at Pittsburgh, Pa., was born at La Porte, Ind., and was educated



W. G. Phelps

in the public and private schools of his native town and of Valparaiso. From 1877 to 1884, Mr. Phelps was telegraph operator and agent on the Vandalia Railroad, and then left the service of that company. On November 5, 1888, he returned to the service of the Vandalia as a clerk in the general freight office at St. Louis, Mo. He was appointed chief clerk to the fourth vice-president of the Pennsylvania Lines West of Pittsburgh on June 9, 1901, and was promoted to assistant purchasing agent on January 1, 1913, with headquarters at Pittsburgh, which position he held at the time of his appointment as purchasing agent of the same road, as above noted.

EARL PRESTON has been appointed storekeeper of the Panhandle division of the Atchison, Topeka & Santa Fe at Waynoka, Okla.

N. R. SNOWDEN has been appointed storekeeper of the Albuquerque division of the Atchison, Topeka & Santa Fe at Belen, N. M.

L. C. THOMSON, storekeeper of the Canadian Northern Ontario, at Toronto, Ont., has been appointed division storekeeper

of the Ontario Grand division of the Canadian Northern, Eastern lines, at Toronto, Ont.

GEORGE E. SCOTT, whose appointment as purchasing agent of the Missouri, Kansas & Texas, at St. Louis, Mo., was announced in the August issue, was born May 27, 1885, at Cleveland, Ohio.



Photo by Matzene, Chicago.

G. E. Scott

He received a grammar school education, and began railway work with the Lake Shore & Michigan Southern in July, 1901, as telegraph messenger at Toledo, Ohio. Subsequently he was clerk to the assistant superintendent and superintendent, and from December, 1905, to January, 1907, was secretary to the general superintendent and assistant general manager of that road at Cleveland. He was then until July, 1911, secretary to the vice-president of the New York Central Lines at Chicago, being made assistant chief clerk to the vice-president on the latter date. In May, 1912, Mr. Scott went to the Missouri, Kansas & Texas, as secretary to the president, and one year later was made assistant purchasing agent. On January 1 of this year he became acting purchasing agent, and on July 1 was appointed purchasing agent, as above noted.

C. B. WILLIAMS, general storekeeper of the Central Railroad of New Jersey at Elizabethport, N. J., has been appointed purchasing agent with office at New York City.

#### OBITUARY

CHARLES R. FRAZER, formerly engine inspector of the Missouri Pacific at St. Louis, Mo., died on August 17 at the age of 66.

DARIUS MILLER, president of the Chicago, Burlington & Quincy and of the Colorado & Southern, died at Glacier Park, Mont., on August 23, after an operation for appendicitis.

MORRIS DAVIS, formerly foreman boiler maker for the Pennsylvania Railroad, died at Altoona, Pa., August 15, at the age of 72. He was employed by the Pennsylvania for almost 50 years and retired on a pension five years ago.

JACOB C. MILLER, formerly master mechanic of the Eastern district of the Chicago, Milwaukee & St. Paul, died suddenly on July 25, at his summer camp on Tomahawk Lake, Minocqua, Wis., from apoplexy, aged 61 years. He retired from active railway service February 1, 1910, since which time he had been living at Maywood, Ill.

ROBERT MORAN, master mechanic of the Louisville & Nashville, with office at Nashville, Tenn., was drowned while bathing at Santa Rosa Island, Fla., on July 31. He was born on February 10, 1857, at Wilmington, Del., and began railway work in November, 1870, as an apprentice in the machine shops of the Edgefield & Kentucky, at Edgefield, Tenn., and since that time he has been in the continuous service of its successor, the Louisville & Nashville and lines now forming part of that road. In December, 1890, he was appointed master mechanic at Bowling Green, Ky., and since February, 1900, was master mechanic at Nashville, Tenn.

JOHN PLAYER, formerly superintendent of machinery of the Atchison, Topeka & Santa Fe at Chicago on August 14

aged 67 years. Mr. Player began railway work in June, 1873, and until September, 1887, was with the Central Iowa consecutively as machinist, general foreman of shops, master mechanic and also in charge of the car department. He then became superintendent of motive power of the Wisconsin Central, leaving that road in June, 1890, to go to the Atchison, Topeka & Santa Fe as superintendent of machinery, which position he held until January, 1902, when he was appointed consulting superintendent of motive power. In June of that year he retired from active railway service on account of ill health.

WILLIAM BARSTOW STRONG, who from 1880 to 1889 was president of the Atchison, Topeka & Santa Fe, died at Los Angeles, Cal., on August 3. He was born at Brownington, Orleans county, Vt., on May 16, 1837, and graduated from Bell's Business College, Chicago, in 1855. He began railway work as station agent and telegraph operator in March of the same year at Milton, Wis., and was later station agent at White Water and at Monroe, and then general western agent of the Southwestern division of the Chicago, Milwaukee & St. Paul at Janesville, Wis. From 1865 to 1867, he was assistant superintendent of the McGregor & Western, now a part of the Chicago, Milwaukee & St. Paul. He was then to 1870 general western agent of the Chicago & North Western, and from 1870 to 1872 was assistant general superintendent of the Chicago, Burlington & Quincy at Burlington, Iowa. In 1872 he was appointed assistant general superintendent of the consolidated Burlington & Missouri River and the Chicago, Burlington & Quincy at Chicago, and in 1874 became general superintendent of the Michigan Central at Chicago. The following year he was appointed general superintendent of the C. B. & Q., and from 1877 to 1880 was vice-president and general manager of the Atchison, Topeka & Santa Fe at Topeka, Kan. He was then president of the same road, with headquarters at Boston, Mass., until 1889, at which time he retired from active service.

## NEW SHOPS

**ATCHISON, TOPEKA & SANTA FE.**—A contract has been awarded for the building of a new reinforced concrete engine house at Albuquerque, N. M., to Henry Bennett & Sons, Topeka, Kan. The estimated cost is \$100,000. Plans are also being made for additional improvements at this point.

**ILLINOIS CENTRAL.**—This company recently started work on the construction of a small mechanical terminal at Dyersburg, Tenn., together with a yard at that place. The total cost of the improvements will be about \$100,000. The buildings will consist of a four-stall roundhouse and boiler house, together with an 85-ft. turntable equipped with electric tractor, all buildings to be of frame construction. The railroad company is doing the grading and track laying, and the construction of the buildings will be let by contract.

**NORFOLK SOUTHERN.**—The Biscoe, N. C., shops of this company have been discontinued and all the machinery has been removed to the company's Glenwood yard shops at Raleigh, N. C. It is not proposed, however, to erect large shops at this point. The company has constructed a six stall engine house, equipped with drop pits, and connected with a new machine shop, 40 by 90 ft. in size, a woodworking shop 30 ft. by 50 ft., an oil house and small storehouse and a 300-ton coaling station and an ash pit. The total expenditure has not exceeded \$30,000.

**PEAT IN THE FALKLAND ISLANDS.**—No less than one-sixth of the total area of the Falkland Islands, which embrace territory amounting to about 6,500 square miles, is entirely composed of peat, having a calorific value and richness which compare favorably with the best peat that is produced.—*Engineering.*

## SUPPLY TRADE NOTES

Graham Dedge, assistant sales manager of the Edgar Steel Seal & Manufacturing Company, Chicago, has been appointed assistant general manager, in addition to his present duties.

C. W. Rhoades has been appointed manager of sales of the Daniels Safety Device Company, manufacturer of the "Bulldog" nut, with office in the Webster building, 327 South La Salle street, Chicago. Mr. Rhoades was formerly assistant sales manager of Valentine & Company, and previously was with the St. Louis Surfacor Company.

Wishing to enlarge the market for the products of their clients, W. L. Rickard, of Rickard & Sloan, Inc., New York, will make an extended trip through South America, leaving New York the latter part of September. He will visit the principal cities on both coasts and will make a thorough investigation of the markets and the best method of selling machinery and mechanical materials and devices.

Willard Doud, formerly shop engineer of the Illinois Central and Chicago, Burlington & Quincy, having completed the special engineering work involved in the construction of the new shops for the Belt Railway of Chicago, at Chicago, announces the opening of offices in the Morton building, 538 South Dearborn street, Chicago, for the handling of all matters pertaining to the design, construction, equipment and operation of railroad and industrial shops and power plants.

Judge Killitts of the United States District Court of the Northern District of Ohio, Western division, on August 15, handed down a decision finding that the Baker valve gear patents Nos. 721,994 and 1,008,405 of the Pilliod Company are valid, and that the Pilliod Brothers Company and Charles J. Pilliod in the manufacture and sale of their so-called B valve gear infringe claim 8 of patent No. 721,994 and claims 1 and 2 of patent 1,008,405. Both defendants are estopped from denying the validity of the latter patent.

Thomas A. Griffin, chairman of the board of directors of the Griffin Wheel Company, Chicago, died on the steamship Korea on the way from Yokohama to Honolulu on August 12. Mr. Griffin was born August 28, 1852, at Rochester, N. Y. His first business experience was as an apprentice at Rochester, and since 1868 he had been continuously in the car wheel manufacturing business. In 1875 he went to Detroit and operated for the Michigan Car Company its plant known as the Detroit Car Wheel Company. In 1879 the Griffin Car Wheel Company of Detroit was organized, and the following year Mr. Griffin went to Chicago, where he organized the Griffin & Wells Foundry Company, which was merged



T. A. Griffin

into the Griffin Wheel & Foundry Company in 1886. Mr. Griffin at this time acquired all of the interest in the Griffin Car Wheel Company at Detroit, and subsequently the name of this company was changed to the Griffin Wheel Company. Besides having five foundries in Chicago the company operates foundries in Boston, St. Paul, Detroit, Kansas City, Denver, Tacoma and Los Angeles.



## CATALOGS

**TELEPHONE CORDS.**—This is the title of a booklet issued by the Western Electric Company, Chicago. It takes up in considerable detail cords used for different classes of telephone service.

**IRON ROOFS.**—A booklet issued by the American Rolling Mill Company, Middletown, Ohio, deals with the subject of iron roofs that resist rust. A number of illustrations are included showing the types of roofing made from Armco iron.

**SHEET METAL.**—The Stark Rolling Mill Company, Canton, Ohio, manufacturer of Toncan metal, has recently issued a booklet dealing with the advantages claimed for this material. A number of illustrations are included showing its application.

**DEFEATING RUST.**—This is the title of a booklet issued by the American Rolling Mill Company, Middletown, Ohio, which gives the story of Armco iron. The booklet contains some historical matter and describes the different uses for this class of iron.

**BOLT CUTTERS.**—A leaflet recently issued by the National Machinery Company, Tiffin, Ohio, deals with accuracy in the cutting of threads. The leaflet includes illustrations of a taper blank before threading, and the same blank after being threaded by a National die head.

**TWIST DRILLS.**—A leaflet issued by the Whitman & Barnes Manufacturing Company, Akron, Ohio, considers the advantages of the high speed twist drills manufactured by that company. A number of these drills were used in the construction of the locks on the Panama Canal.

**FUEL OIL ENGINES.**—Bulletin No. 34-W from the Chicago Pneumatic Tool Company, Chicago, is devoted to the Giant low grade fuel oil engines. The bulletin describes and illustrates the details of construction and gives a list of the sizes and capacities in which the engine is made.

**WATER GAGES.**—A pamphlet from the Prince-Groff Company, 50 Church street, New York, describes the Pressurlokd water gage. As the name indicates, the glass is sealed by the water pressure and the gage is so arranged that in case of a broken glass the fractures are kept closed.

**SPRAYERS AND WHITEWASHERS.**—Catalog No. 176 from the Dayton Manufacturing Company, Dayton, Ohio, describes the Dayton sprayers and whitewashers. These sprayers are adaptable to a number of uses, including the application of whitewash, water paints and other wall coatings.

**PIPE WRENCHES.**—The Prince-Groff Company, 50 Church street, New York, has issued a leaflet devoted to the Kwikgrip pipe wrench. The advantage claimed for this wrench lies in the construction of the jaws, the jaw containing the teeth being placed parallel with the center line of the handle.

**PORTABLE FLOOR CRANES.**—The Canton Foundry & Machine Company, Canton, Ohio, has sent out a booklet describing the portable floor crane and hoist manufactured by that company. These cranes are made in a number of sizes and are so arranged that they can be readily moved by hand from place to place about a shop.

**AIR COMPRESSOR VALVES.**—Bulletin No. 3024, issued by the Ingersoll-Rand Company, 11 Broadway, New York, is devoted to the discussion of the Ingersoll-Rogler valves for air compressing cylinders. This bulletin takes up this type of valve in more detail than bulletin No. 3030, which deals with the complete air compressor.

**MAGNETO TELEPHONES.**—Magneto telephones and supplies is the subject of a 40-page catalog issued by the Western Electric Company, Chicago. The catalog lists only such standard telephone apparatus and supplies as are generally used by a tele-

phone company using magneto equipment and having about 200 telephones or less.

**BALL BEARINGS IN MACHINE TOOLS.**—This is the subject of a catalog issued recently by the Hess-Bright Manufacturing Company, Philadelphia, Pa. It contains a brief history of early ball bearings, and after devoting some space to the origin of the annular type takes up the application of ball bearings to different classes of machine tools.

**CONVEYOR SCALES.**—The Electric Weighing Company, New York, has issued bulletin No. 8 which deals with the conveyor scales manufactured by this company for use with various types of belt and bucket conveyors. A number of electric specialties are also briefly described, including a recording counter and an ampere hour meter. The leaflet contains 18 pages and has a number of illustrations.

**PIPE THREADING MACHINE.**—A booklet entitled Actual Pipe Threading Experiences II has been received from the Oster Manufacturing Company, East Sixty-first street, Cleveland, Ohio. This booklet deals largely with the experience of a number of users of Oster pipe threading machines. It also contains several illustrations and a short description of the practices followed in the manufacture of these machines.

**AIR COMPRESSORS.**—Bulletin No. 3030 from the Ingersoll-Rand Company, 11 Broadway, New York, describes the Ingersoll-Rogler, class ER-1, power driven, single phase, straight line air compressor. The distinguishing feature of this compressor is the type of air valve which is considered at some length in the pamphlet. Illustrations are included showing the construction of the valve as well as different parts of the compressor.

**VALVELESS ENGINES.**—From stone cold to full power in 10 seconds is the subject of an illustrated catalog issued by the Harris Patents Company, Philadelphia, Pa., and describing the Harris valveless engine which is constructed on the Diesel principle. Among the drawings included are those for a locomotive equipped with a 320 indicated h. p. Harris valveless engine. The Harris high and low pressure air compressor is also described.

**PUMPING MACHINERY.**—Bulletins 10 and 11 from the National Transit Company, Oil City, Pa., are devoted to pumping machinery. These bulletins are issued with a view to making a flexible catalog bound in loose leaf covers. Bulletin No. 10 gives directions for setting up an operating pump, and also deals with duplex piston pumps and vertical triplex power pumps. Bulletin No. 11 is devoted to different sizes of duplex piston pumps and includes a list of parts.

**THE YOUNG MAN AND THE ELECTRICAL INDUSTRY.**—This is the title of special publication No. 1542 recently issued by the Westinghouse Electric & Manufacturing Company, Pittsburgh, Pa. It is a reprint of an article by James H. Collins which appeared in the Scientific American, May 16, 1914. It deals in an interesting way with the opportunities afforded a young man in this industry and the different lines in which he may direct his activities, as exemplified by the works of the Westinghouse company. A copy of the booklet will be sent on request to any one interested in the development of young men.

**RELATIVE CORROSION OF IRON AND STEEL PIPE.**—National bulletin No. 10-C from the National Tube Company, Pittsburgh, Pa., contains an illustrated article giving the results of an investigation into the relative rust of iron and steel pipes which have been in continuous service for a considerable number of years. This investigation was conducted by William H. Walker, Ph.D., professor of industrial chemistry and director of the research laboratory of applied chemistry, Massachusetts Institute of Technology, Boston; the article is an abstract of a paper read before the New England Water Works Association. In addition, the bulletin contains three other articles on the subject of corrosion.

# Railway Age Gazette

MECHANICAL EDITION

INCLUDING THE AMERICAN ENGINEER

PUBLISHED ON THE FIRST THURSDAY OF EVERY MONTH BY THE SIMMONS-BOARDMAN PUBLISHING COMPANY, WOOLWORTH BUILDING, NEW YORK, N. Y.

CHICAGO: Transportation Bldg. CLEVELAND: Citizen's Bldg. LONDON: Queen Anne's Chambers, Westminster.

EDWARD A. SIMMONS, President L. B. SHERMAN, Vice-President

HENRY LEE, Secretary

The address of the company is the address of the officers.

ROY V. WRIGHT, Editor

R. E. THAYER, Associate Editor C. B. PECK, Associate Editor  
A. C. LOUDON, Associate Editor GEORGE L. FOWLER, Associate Editor

Subscriptions, including the eight daily editions of the *Railway Age Gazette* published in June in connection with the annual conventions of the Master Car Builders' and American Railway Master Mechanics' Associations, payable in advance and postage free:

United States, Canada and Mexico.....	\$2.00 a year
Foreign Countries (excepting daily editions)....	3.00 a year
Single Copy .....	20 cents

Entered at the Post Office at New York, N. Y., as mail matter of the second class.

WE GUARANTEE, that of this issue 4,150 copies were printed; that of these 4,150 copies 3,651 were mailed to regular paid subscribers, 150 were provided for counter and news companies sales, 232 were mailed to advertisers, exchanges and correspondents, and 117 were provided for samples and office use; that the total copies printed this year to date were 43,100, an average of 4,310 copies a month.

VOLUME 88

OCTOBER, 1914

NUMBER 10

## CONTENTS

### EDITORIALS:

Car Department Competition.....	501
Educate the Engine Crews.....	501
Special Man for Laying Out.....	501
Reclaiming Material on the Frisco.....	501
Employees' Responsibility in Promoting Economy.....	502
The Road Foreman's Part in Preventing Failures.....	502
British Steel Coaches.....	502
Provide Adequate Coaling Facilities at Terminals.....	502
Traveling Engineers' Convention.....	503
New Books .....	503

### COMMUNICATIONS:

The Special Apprentice.....	504
Handling Metallic Packing in Roundhouses.....	504
The Draft Gear Problem.....	504

### GENERAL:

Traveling Engineers' Convention.....	505
Some English Locomotive Appliances.....	512
Metal Pilot on the Lehigh Valley.....	513
Ringleman Smoke Chart.....	514
Device for Feeding Boiler Compound.....	514

### CAR DEPARTMENT:

Steel Underframes for Use on Wooden Freight Cars.....	515
Saving Car Days .....	516
Long Island Steel Baggage Car.....	517
Car Department Correspondence .....	521
Special Dining Car for Troops.....	522
Coach Step with Four Treads.....	523
Steel Construction in Foreign Cars.....	523
Form for Noting Freight Car Repairs.....	526

### SHOP PRACTICE:

Master Painters' Convention.....	527
Reclaiming Material on the Frisco.....	531
Burning Out Oil Deposits in Air Pumps.....	538

### NEW DEVICES:

Recent Designs of Engine and Tender Trucks.....	539
Portable Steam Sterilizer .....	541
Portable Arc Welder .....	541
Structural Steel Tender Truck.....	542
Reflex Water Gage with Metal Encased Glass.....	542
Double Spindle Lathe .....	543
Locomotive By-Pass Drifting Valve.....	544
Gravity Boiler Washing System.....	545
Malleable Iron Welded by Oxy-Acetylene.....	546
Corrugated Steel Door with Fender Attachment.....	547
Staybolt Chuck .....	547
Mudge-Peerless Ventilator .....	548
Soft Metal Grinders for Superheater Unit Connections.....	549
Gravity Fire Door .....	550

### NEWS DEPARTMENT:

Notes .....	551
Meetings and Conventions.....	552
Personals .....	553
New Shows .....	555
Supply Trade Notes .....	555
Catalogs .....	556

### Car Department Competition

The competition on defective box cars and how the defects may be overcome or remedied, which was announced in our August and September issues, will close on October 15. Because of the considerable amount of attention which was given to the draft gear problem in the earlier competition it is the purpose in the present one to leave the draft gear out of consideration. A first prize of \$50 will be awarded for the paper containing the most practical suggestions for remedying the defects; papers not awarded a prize, but accepted for publication, will be paid for at our regular space rates.

### Educate the Engine Crews

"Educate the Engine Crews" might well be taken as the slogan of the twenty-second annual convention of the Traveling Engineers' Association, held in Chicago last month. We do not wish to infer, however, that the enginemen on American railroads are ignorant, for such is not the case. Our enginemen are a fine class of men; if they were otherwise they wouldn't be where they are. What is meant is that with the introduction of the various labor saving and economical devices on locomotives the engine crew must be carefully and thoroughly instructed as to their proper manipulation in order that the greatest benefit may be obtained from their use. This is especially true of smoke eliminating devices, the superheater and the stoker. In every subject considered at the convention the proper education of the engine crew was believed to be the key note of success.

### Special Man for Laying Out

The practice of assigning a special expert mechanic to laying out all work to be done in a machine shop has been found to be especially advantageous from many standpoints. A man who has this special duty will naturally become very proficient and will be able to lay out more work in a given time than the men by whom the work is to be machined. The practice saves the time of the machines, as well as the men, for the operators do not have to hold their machines idle while the work is being laid out. If a piece of work is not of the proper dimensions it will get no farther than the layer-out, whereas in the absence of this system it is likely to have been placed in position on the machine. Under this plan all jigs and templates are put in one place and under the care of one man, the layer-out, and are therefore kept in good condition and where they can be found when they are wanted. There is less chance for error in the finished dimensions, and as a whole the work can be put through the shop with much greater despatch.

### Reclaiming Material on the Frisco

The handling and reclaiming of scrap material has been a troublesome problem to the railroads for many years. Different roads have tackled it in different ways. In some cases, due to faulty accounting or lack of appreciation of the relative value of the various factors entering into the problem, methods have been adopted which finally proved to be far from economical; in other cases good judgment has made it possible to reclaim certain parts of the scrap with splendid results. The Santa Fe, a few years ago, established a large plant for handling and reclaiming scrap at Corwith, Ill., near Chicago. The savings effected for the year ending June, 1913, are said to have amounted to half a million dollars. A similar plant which is very fully described in another part of this issue has been developed on the St. Louis & San Francisco during the past year. It was fully realized in inaugurating this work that unless a most careful check was kept on each individual item there would be a tendency to actually waste money in the attempt to reclaim parts which could not be handled with profit. To avoid this great care is taken to study the detailed costs of



reclaiming each item, and to follow it into service to make sure that it does its work properly and does not fail prematurely. As in the case of the plant at Corwith the oxy-acetylene apparatus is a most important factor, not only in the making of repairs but in cutting certain classes of scrap, such as fireboxes and tender tanks, into parts of such size that they may be more easily handled and bring a much better price per pound as scrap.

**Employees' Responsibility in Promoting Economy** Any one who has worked in a railroad shop is familiar with the expression "The company is rich; it can stand it." It is a matter of common occurrence for a man to make such a remark to his fellow employees in good-natured justification of a waste of time or material. In the minds of a surprisingly large number of railway employees the company for which they work is a corporation of almost unlimited wealth; to them the company means the higher officers, and they do not realize that although the financial receipts may be large the expenditures are probably of a size to leave but a small margin of profit. They feel amply justified in getting all they can out of the company and consequently a waste of half an hour in a locomotive firebox or the throwing into the scrap pile of a tool that could be repaired at a slight cost are items which from their viewpoint affect the company's treasury to such a small degree as to be entirely negligible. There is wide opportunity for economy in bringing railway men in general and shop employees in particular to realize that time and material which they can save in their personal work can have a direct and considerable bearing on the condition of the company's treasury and consequently on their own prosperity. While means should be taken to instill these ideas into the older employees, the place for the most earnest efforts is in the apprentice school, and in this connection the simpler the explanation can be made the better. It is of little use to try to explain to a class of apprentices by making use of long lists of figures and financial terms, but there is no reason why a simple explanation cannot be given of what a company is, how it is organized and what class of people make up the bulk of its stockholders. In many instances the lesson will be kept in mind and while it seems a hopeless task to bring all employees to a correct understanding of such matters, a continued process of education and enlightenment will result in a surprising increase in the efforts of individual employees toward economy.

**The Road Foreman's Part in Preventing Failures** There were several points dwelt upon by J. F. DeVoy, assistant superintendent of motive power of the Chicago, Milwaukee & St. Paul, in his address at the recent convention of the Traveling Engineers' Association which should meet with general approval. Among these was the statement that the traveling engineer, or to use the better title, road foreman of engines, should not spend too much time investigating failures and delays, but should get out on the road and work with the men to prevent such occurrences. Unquestionably the road foreman must conduct investigations, but he should not, as is very often the case, spend almost his entire time in conducting them and in preparing long reports. The road foreman of engines is often made too much of an investigator and in consequence degenerates to a seeker after the cause of troubles that have become ancient history.

There will always be investigations to be held and that consideration cannot be neglected, but by his methods in dealing with the men under him the foreman can greatly reduce these in number. His most important duty should be to educate and develop a class of men who will use their thinking powers in such a way that they will keep out of trouble. A man who is appointed to the position of road foreman of engines should be of an even temperament and have a disposition which will com-

mand the friendly feeling and respect of those under him; he should be capable of training men, and in investigations of getting at all the evidence, weighing it judicially and basing his decision on sound reasoning. The selection and training of firemen, which should devolve upon the road foreman, should be given as much if not more care than the selection and training of shop apprentices. A man without the proper qualifications who is appointed to the position of road foreman of engines is likely to make poor selections in hiring men and ill-judged decisions in enforcing discipline, and can do much more harm than good. The selection of a man for the position of road foreman is a matter which should always receive the most careful attention of the officers making the appointment.

**British Steel Coaches** Several of the features of British practice in the construction of steel passenger equipment which are brought out in an article appearing elsewhere in this issue will be rather difficult of explanation, if not entirely unaccountable to American car builders. While as a whole the Metropolitan District car therein illustrated is not typical of British construction, the underframe is of a type very similar to that frequently used on cars with wooden superstructures. The typical features of this underframe are the use of four longitudinal members of uniform cross section, the placing of truss rods below some of the longitudinal members and the design of the cross-members, which are offset to pass under the center longitudinals. With the type of couplers and buffers used on British coaches the buffing and pulling stresses are more readily distributed over the entire underframe than would be possible with the type of draft gear used in this country; and the uniform size of longitudinal members as well as their spacing may thus be logically accounted for. It is difficult, however, to logically account for the use of truss rods with steel underframe construction. With wood sills the use of truss rods is very effective, the amount of initial tension required in the rods being small because of the comparatively large deflection of the wood sills under load. With steel sills the case is entirely different. Unless the rods are adjusted to have an excessive initial tension the deflection of the sills necessary before full advantage of the truss rods is obtained might be close to or even exceed the elastic limit of the material in the sills. If placed under sufficient initial tension to insure effective service the margin of strength available for service will be greatly reduced. In other words it would seem that the great precision of adjustment required is such as to make the strength of the arrangement very uncertain. Taken altogether, British steel construction appears to have gone very little beyond the substitution of steel members for those originally of wood, the original form of construction being closely followed. Practically no attempt seems to have been made to take advantage of the possibilities offered by steel construction.

**Provide Adequate Coaling Facilities at Terminals**

It is surprising how many times in laying out new engine terminals, or renewing old ones, careful provision is made for a modern engine house at the expense of the coaling and ash pit facilities. It is not intended by any means to decry the need of providing a strictly adequate and up-to-date engine house with corresponding repair equipment; the idea that any kind of a building fitted with cast-off tools and other equipment is good enough for carrying on terminal repairs to locomotives is a wrong one, and has fortunately, to a considerable extent, been gotten away from within recent years. But when a certain number of trains are handled daily on a division, a corresponding number of engines must be turned at the engine house, and it matters not how nearly perfect the repair facilities may be if the equipment for coaling and the handling of ashes, which constitute the neck of the bottle, is sufficient. There is nothing more annoying to an engine house foreman than a con-

gested coaling station or ash pit, and there is nothing that is more productive of terminal delays. When traffic is heavy, and particularly in cold weather, an inadequate coaling station or ash pit will result in a line of locomotives standing out doors possibly for several hours when they should be in the engine house undergoing repairs. In consequence more work is necessitated by some of the engines arriving at the ash pit with frozen hopper slides, or finally reaching the engine house with frozen injector supply or delivery pipes, or leaky tubes. Under such conditions a foreman is likely to resort to putting some of the engines in the house without coal, and even in extremities dumping fires in the engine house pits. This latter practice is extremely dangerous, as a fire may very easily be started if there is a wooden floor. In any event it is necessary to stop long enough to coal the engine on the way out, with the likelihood of a terminal delay resulting. It is, of course, most desirable to provide an engine terminal complete in every particular, but in cases where some part of the plant has to be skimmed because of a lack of money, it is much better in the interests of the prompt moving of traffic to provide ample coaling and ash pit facilities and permit part of the engine house facilities to remain uncompleted until a later date when financial conditions are better.

### Traveling Engineers' Convention

"A successful convention" has become a habit with this association with all the intensifying characteristics a "habit" has. The meeting was well attended both in

registration and the number of members sitting in the convention hall. Four days of hard work from shortly after nine in the morning until after five in the afternoon was the pace set by President Roesch and to the credit of the association the members were as strong at the finish as at the start.

Some very important subjects were covered this year, two of which should be particularly mentioned, "The Care of Locomotive Brake Equipment" and "The Efficient Operation of Locomotives." The former paper was presented in such detail and contains such valuable information that it would pay a road to have it bound separately and distributed to all employees that are concerned in the maintenance and care of the air brake on locomotives. The air brake is a very important item in train operation. It is as important as the locomotive itself under the present day requirements in the operation of trains, for without it the density of traffic could not be anything like what it is. The air brake if not properly maintained may cause serious trouble from wrecks, which means loss of money to the railroad. It therefore is a large factor in the operating expense of any road. In view of the vital part it plays in the train operation it seems that almost any expense made to insure its proper operation would be justified. A careful terminal inspection, both on arriving and on leaving, is positively necessary for economical operation. The enginemen should be made to realize the importance of reporting every defect in the air brake system that comes to their attention, and in justice to themselves and their families, if not to the railroad that employs them, they should insist on the air brake system being in perfect condition before leaving the terminal.

The efficient operation of the locomotive is chiefly the result of proper education of the engine crews and of the men making inspections and repairs on locomotives. The enginemen should be assisted and encouraged in efficient operation by making their work as light and convenient as possible. Nothing will please an engineer more than a conveniently arranged locomotive cab and a free running, well maintained engine. Under such conditions he will be more liable to use thought and care in the handling of his engine and seek to get the most out of it. The fireman also will do his part when he finds that the company desires to aid him in his work. If the fire door is loosely hung so that it requires an effort to open and close it, will the fireman follow the "one scoop to a fire" plan con-

scientiously? If the flues are plugged or leaking will he try to save coal so that it may be wasted through an inefficient boiler? All of the employees must be met half way, the engine crew with a properly designed and properly maintained locomotive, and the repair men with proper tools with which to do the work. Labor is the largest item of expense in locomotive maintenance and operation, with the exception of the fuel, and money invested to encourage labor to give its best efforts will be well invested.

Another item which greatly affects the cost of locomotive operation is the terminal facilities for turning and handling power. This subject is a large study by itself, especially on a road that operates its locomotives on a pooled basis. Investigations have shown that power is in the hands of the mechanical department the greater part of every 24 hours. To overcome this delay careful study of the terminal facilities and organization should be made.

The arguments for regularly assigned engines for the engine crews was so overwhelming that there can be no question as to where the association stands in this regard. Various illuminating records of what had been accomplished by the regularly assigned engine plan as against the pooled system showed that from an operating standpoint, at any rate, the former was much the more economical and satisfactory method to adopt. From the number of roads that have given up the pooled system it would seem that there is no question as to the economy of the regularly assigned engines plan.

The attitude of the association could be considered as "extremely enthusiastic" in regard to the locomotive mechanical stoker. The stoker has been applied for a sufficient length of time to give the enginemen an opportunity of becoming thoroughly familiar with it, and the opinions of the traveling engineers might be taken as a direct reflection of the opinions of the enginemen themselves. We hear this year of the increased tonnage that may be handled with the stoker fired locomotive without, in two cases at least, any more fuel being used than would be required with the hand fired engines. The stokers are accepted as having a distinct advantage in certain classes of service and the traveling engineers look to them to greatly improve operating conditions.

The paper on the "Practical Chemistry of Combustion," by Mr. Kinyon will round out the proceedings of this convention into a volume of instruction that will be of value and credit to the members of the Traveling Engineers' Association.

### NEW BOOKS

*Air Brake Association. Proceedings of the 1914 convention. Illustrated, 242 pages, 6 in. by 9 in. Published by the association. F. M. Nellis, 53 State street, Boston, Mass., secretary. Price \$2.*

The Air Brake Association has made a record this year in placing the bound volume of the twenty-first annual convention in the hands of the members about two months after the convention met. This year's report includes addresses by H. H. Vaughan, assistant to vice-president, Canadian Pacific, and W. A. Garrett, formerly chief executive officer of the Pere Marquette, together with papers on Air Hose, Caboose Air Gage and Conductor's Valve, Electro-Pneumatic Signal System for Passenger Trains, Modern Train Building, and the report of the committee on Recommended Practice. Other subjects discussed were the Clasp Type of Foundation Brake Gear for Heavy Passenger Equipment Cars, and One Hundred Per Cent Efficiency of Air Brakes. A tribute to George Westinghouse is also included in the proceedings. By prompt action of the executive committee immediately following the convention in Detroit, the secretary has been able to include in these proceedings the list of subjects selected and the committees appointed to report at the twenty-second annual convention, which will be held in Chicago, May 4-7, 1915.



## COMMUNICATIONS

### THE SPECIAL APPRENTICE

PORT JERVIS, N. Y., August 10, 1914.

TO THE EDITOR:

Owing to his college training the special apprentice is able to do many things of value outside of routine machine shop work and frequently this prevents his obtaining more practical experience. The apprentice of this class should be given a chance to learn his trade and not be sent out on all sorts of testing work, except for a short period of his course. The college man of the right material is willing to work and to learn and should be subject to the same rulings as a regular apprentice. The trouble is that the selection of a special apprentice is not made very carefully; no young man who has not graduated from a recognized technical school should be even considered. He should be given a six months' trial period and carefully watched; then if in the opinion of the supervising officer, he is unfit for the work, he should be told so definitely and not left to drag along till he gets discouraged and quits of his own accord. If a proper selection is made by a careful officer, the railroad will obtain a young man who has spent most of his life studying and surely it can well afford to devote some effort to educate him further along its lines of work.

R. W. ROGERS,

Instructor of Apprentices, Erie Railroad.

### HANDLING METALLIC PACKING IN ROUNDHOUSES

CHICAGO, Ill., August 17, 1914.

TO THE EDITOR:

The writer, having visited most of the railroads in the United States and Canada and observed the different practices in use in handling metallic packing matters, more especially in the roundhouses, has come to the conclusion that, especially at all large roundhouses, it will be found to be one of the best paying propositions to have a good machinist assigned to do all the packing of piston, valve and air pump rods. If such a man is on to his job, he can more than save his wages very easily. It is reasonable to suppose that the man who is held responsible will see to it when he packs a rod that that rod is packed in the best possible manner to insure its running without blowing until the packing is fully worn out. He will see to it that the equipment is in good shape and the swab is well lubricated, as he will realize that if his work is not properly done he will have the same job to do over again. The packing man should be furnished a small pocket record book wherein he should keep a complete record of all rods packed during the day. A printed form should then be used in reporting all rods packed during the week to the division master mechanic each week. These records would indicate, should an engine be packed quite often, that something was wrong. Investigation would show why so much packing had been applied and the proper remedy to overcome the trouble would then be applied.

In other words, the packing man would become a specialist in his work. He certainly would try and make a showing. To do this he would make his business a study. He should be encouraged as much as possible by the roundhouse foremen and others who would see that guides, pistons, etc., were kept in good condition. On a few roads it has been found advisable to have a monthly inspection of pistons, piston rings, etc., on superheater engines. On such inspection days the packing man should also look over his packing and equipment and see that it is in good shape, this being the proper and best time to do any work necessary on vibrating cups, followers, etc. It will be found on a road where this practice is carried out and watched that there will be practically no packing troubles. If there are any, the division master mechanic can very easily trace them and stop the trouble. His weekly packing sheets will keep him advised as to just what is being done and what points are using

the most packing. His clerk can make a monthly report for the general superintendent of motive power, if desired, but the main object and result would be that the rods will be packed right and a great deal less packing used.

A. E. M.

### THE DRAFT GEAR PROBLEM

EASTERN STATE, September 14, 1914.

TO THE EDITOR:

I have read with much interest the various articles on draft gear which have appeared from time to time in your journal. Some of them have spoken in favor of the friction gear and others have been in favor of the spring gear. No doubt both types of gear have their good points, but is there any draft gear on the market today that will meet the requirements imposed upon it? I believe the answer is, NO.

Some manufacturers of friction draft gears claim that their gears have a capacity of 300,000 lb., which no doubt is true when the gear is tested on a static machine, but the conditions of actual service are entirely different from this and there is therefore no comparison between them. The only way in which a friction draft gear can absorb the energy of the blow imposed upon it is by changing that energy into another form of energy, namely, heat.

The question, therefore, resolves itself into the problem of getting a gear which will transform into heat the greatest amount of energy in the shortest time and still be elastic enough to take care of the minor shocks which cars are continually receiving.

The element of time is one of the most important factors to be considered. Draft gear designers have, in most cases, limited the travel of the gear to the same as is used with a spring gear. The only way in which the time used in absorbing the shock can be increased is by increasing the travel of the gear and some day we will see gears with seven to ten inches of travel. A loaded 50-ton capacity car running 10 miles an hour will develop 450,000 foot-pounds. If this total amount of energy was transformed into heat in the time that it takes the draft gear to travel  $2\frac{1}{4}$  in. at the above speed, and with the small wearing surfaces at present used in friction gears, the entire gear would be welded together.

I have talked with several friction draft gear men and have asked them all the question, "If a blow of 100,000 foot-pounds is delivered to your gear, what part of that 100,000 foot-pounds is absorbed by the gear and what part is transferred to the draft gear supports?", and not one has been able to answer it.

The drop test is now largely used in an endeavor to duplicate; in the laboratory, actual service conditions, and I believe these tests clearly demonstrate one great fault existing in some of the present friction gears. This is that the angles of the friction blocks are such that the blocks move a relatively great distance with a given movement of the coupler. The movement of the blocks is restrained by springs, and when a blow is delivered to the coupler this is what takes place: the friction blocks move at a high velocity and their inertia overcomes the resistance of the springs and compresses them, and the pressure between the blocks is reduced. As the time consumed is but a small fraction of a second, the gear has completed its full travel and the coupler horn has come in contact with the striking plate and the major portion of the blow is delivered to the car underframe before the springs can overcome the inertia of the friction blocks and force them back into contact or normal position.

Conclusions.—What is needed in a friction gear is springs to take care of the minor shocks and encased friction blocks not depending on springs for contact, but relying upon the force of the shock to hold them in contact. The whole to have a total travel which will give sufficient time to transform the energy of the shock into heat. The friction surfaces must also be of such size as to safely conduct the heat generated to other parts of the gear.

MECHANICAL ENGINEER.

# TRAVELING ENGINEERS' CONVENTION

## Discussion on Locomotive Operation, Air Brake Maintenance, Mechanical Stokers and Speed Recorders

The twenty-second annual convention of the Traveling Engineers' Association was held at the Hotel Sherman, Chicago, September 15 to 18, E. P. Roesch, El Paso & Southwestern, presiding. The convention was opened with prayer by the Rt. Rev. Samuel Fallows, Bishop of the Reformed Episcopal Church.

ADDRESS OF J. F. DE VOY

J. F. De Voy, assistant superintendent of motive power, Chicago, Milwaukee & St. Paul, addressed the convention in part as follows:

This association must go farther in its efforts to handle railroad business with the least possible amount of expense, before it has entirely fulfilled its obligations, not only to the railroads, but to the entire country. Railroad earnings have continued to make an unsatisfactory showing. Gross earnings of all roads so far reported for the first seven months of the year are 6 per cent below the same period of 1913. The falling off in earnings has taken place in all parts of the country and on nearly all roads. The small freight rate advances permitted by the recent ruling of the Interstate Commerce Commission will not be sufficient to change this situation to any appreciable degree. During the past five years freight rates per ton mile have decreased about 4 per cent, while the average daily wage of railroad employees has increased about 14 per cent. This leaves an item of something like 250 million dollars to be offset by more economical management. We are not prepared to believe that the management of railroads generally has been so profligate that 250 million dollars can be saved in a year by better management, and this without in any way crippling the service.

There is no question that your association has helped by better methods and management to make up some of the losses in the earnings due to increased taxes and higher rates for material and wages, but the fact still remains that the difference between the expenditure and earnings of the railroad companies from different causes has been unsatisfactory.

Until such time as organizations similar to yours take a hand in the management of affairs other than those directly pertinent to your business, there will be no true equalization of the difficulties which it seems to me must come to all railroad business. It is this condition which all who are working along lines to better general conditions must keep uppermost in mind, and do their share to educate the people up to a full and proper understanding of the true conditions that prevail in your line of business.

It was about 25 years ago when the first traveling engineers were used on the railroads in this section of the country. The change from a few to many enginemen on any specified division brought about a condition where it was impossible for the master mechanic and the superintendent to come into as close contact with the individual engineman as was necessary for economical and safe operation. These conditions were responsible for the creation of the position of traveling engineer. On some roads this position has been developed until the title "Traveling Engineer" would not fit in with the duties of the position and they have more properly applied the title "Road Foreman of Engines."

In order that an engineer may become a successful traveling engineer, it is very evident that he must be able to do many things well that are not required of a man running an engine. The motive power officers who have the selection and appointing of traveling engineers must give this question a great deal of thought in order to get men for the place who will be able to do

the various things required in a satisfactory manner. The man selected must himself be capable of doing what he expects of the enginemen he is instructing and he must be able to do this in a manner which will not tend to antagonize the enginemen and to get from them their best possible efforts. He must be a man in whom his superior officers have absolute confidence, so that when he makes a report on an engineman in the operation of an engine, or the performance of any locomotive or special equipment, it will be received as representing actual conditions and considered as final.

Opinions differ greatly as to the territory, the number of engines and men which should be assigned to any one traveling engineer. It is my opinion that best results are obtained with a system making it possible for traveling engineers to ride with each crew and engine at least once a month. His territory should not be so great but that he can get to any part of it in a few hours. Very often an engine crew makes a poor performance due to error in judgment, and where it is possible to have a traveling engineer ride with that crew on its next trip, a correction can be effected and subsequent delays or trouble avoided.

In looking over the requirements of some roads, I note that the same burden of making numerous written reports is imposed upon traveling engineers as on the other officers. The fewer reports required, the better results. It is much more satisfactory to motive power and operating officers to secure a short report from a traveling engineer advising of corrections made or matters adjusted, than to have a long detailed report of every move made. A traveling engineer who can himself improve conditions is much more valuable to any railroad company than one who is continually telling his superiors what someone else in another department should do. A traveling engineer should keep in touch at all times when on the road with the train dispatcher, so that in case anything occurs, requiring his services, he can be promptly notified. He should keep in close touch with the roundhouse foreman and the roundhouse force and when he finds a locomotive which requires attention, he should not be satisfied by making a report to the foreman, but he should stay around and see that the work is done. There are altogether too many reports being made by all classes of officers and not enough attention is being given to the bettering of bad conditions instead of only writing about them. I do not believe the best results are obtained by having the traveling engineer spend too much of his time investigating cases of failure and delay. He can do more good working with the men in lining them up to prevent similar failures and delays. It has been said that the roundhouse foreman and the train dispatcher run a railroad. It is true that what a good trainmaster is to the operating department, a traveling engineer is to the motive power department.

PRESIDENT'S ADDRESS

Since last we met several events of serious import have transpired. I refer to the war in Europe, the threatened railway strike in this country and the tentative settlement of the Eastern railway rate case. Of these the final outcome of the first is as yet problematic. The second is in the process of settlement by arbitration. The influence of the third, however, is much with us and demands our serious consideration. While a few slight increases were granted outright the commission seemed to infer that the railroads could more readily increase their earnings by indicated operating economies than by an arbitrary increase in rates. As a matter of fact, the railroads have for years been working along the principal lines suggested by the commission, and while the results have been encouraging they have not by any means been so easy of achievement nor as remunerative as the commission



appears to think possible. Be that as it may, the only recourse left to us is to make the best of it and try by every means in our power to carry out such of the recommendations as come within our province. In our own particular field of work we are primarily interested in the problem of transportation and the efficiency of the machines handling it. We find in late years that the railroads have adopted every known mechanical appliance that increases the efficiency of the locomotive and at the same time has a tendency to decrease cost of operation, but regardless of the increased efficiency of the machine in the final analysis we arrive at the old, basic principle that the performance of the machine depends upon the man operating it. As conditions are rapidly changing men must change or be changed to meet the new conditions. This means more and closer supervision and a higher degree of initial training. In employing new men to fill the ranks hereafter more attention must be paid to their mental than to their physical qualifications, and before any new men are placed in service they should be thoroughly grounded in the principles and manipulation of such appliances as come within their line of work, so that on their initial trip they can in return for a journeyman's wage render approximately a journeyman's service. Under the conditions prevailing on the majority of American railroads today it takes fully one year before the average student becomes what might be termed a fairly good all round fireman. This being the case, it must follow that during his probationary period or learning time his work represents a distinct loss to the company as compared with that of the experienced man. The same may be said to be true in a measure of many of our newly promoted engineers. Therefore, if the aspiring student be given a thorough preliminary training before he is ever placed in service and this training be then continued throughout his firing period with a view of fitting him for the position of engineer, there is no question but that the losses incidental to the student period, that is, the first year's service, in either capacity, could be almost wholly eliminated. With the increase in size of the modern locomotive and train and the refinement of operation made necessary, the losses due to unskillful handling are being rapidly increased and multiplied. These losses we wish to avoid by correct training. Several railroads have already a practically similar plan in effect and it is only necessary to call attention to some of them, as, for instance, the Erie, to show what supervision and training can accomplish toward a reduction in expense.

You have no doubt noticed that most of the items as suggested by the commission, if carried out, would involve some increase in initial expense, and the plan here outlined would in the beginning result in increased costs due to increase in supervision. It may, therefore, be a rather difficult matter to induce some of our managements to increase present expenses on the promise of future economy, but to my mind this is the only solution of the particular problem, namely, if we wish to increase the efficiency of the service we must first increase the efficiency of the men performing that service. This I believe is the longest step that we can take toward carrying out the recommendations of the commission.

Another item whereby some saving may be effected is to have enginemen inspect for and report such defects as come under the rules of the boiler inspection and safety appliance bureaus. This would entail no extra work on the part of the enginemen and might at some time avoid a violation of the law or at least an expensive delay.

ADDRESS BY H. C. BAYLESS

H. C. Bayless, mechanical engineer, Minneapolis, St. Paul & Sault Ste. Marie, addressed the association on Wednesday. He spoke of the increasing importance of the traveling engineer. The higher mechanical officers have become so loaded down with routine reports and investigations required by the government that the actual mechanical department work is being done by their assistants. For this reason the traveling engineer has a

good opportunity to broaden himself in mechanical department work. He must be prepared to make efficiency studies of the various new mechanical devices applied to locomotives and seek data and information on fuel economy, valve gears, and such things for the good of the service. From his wide experience of locomotive operation he should be of assistance to the drawing office when new engines are being designed. The highest efficiency in operation has become necessary in order to meet the decreasing revenues and adverse legislation, and this alone presents a wide field for the ingenuity of the traveling engineer on his own road.

ADDRESS BY FRANK MCMANAMY

Frank McManamy, chief inspector of locomotive boilers, Interstate Commerce Commission, addressed the association Wednesday afternoon, calling attention to the many ways in which the traveling engineers and the government inspectors may be of assistance to each other. Attention was called to the increasing number of locomotives inspected by the 50 government inspectors, and the decreasing number of locomotives found defective, which is a credit to both the inspectors and the railroads. In the year 1912, 74,234 locomotives were inspected, of which 65.7 per cent were found with reportable defects; in 1913, 90,356 locomotives were inspected and 60.3 per cent were defective, and in 1914, 92,716 locomotives were inspected, of which 52.9 per cent were found with reportable defects. All of these, however, were not in direct violation of the law. Those that were in violation represented 4.5 per cent in 1912, 5.2 per cent in 1913, and 3.6 per cent in 1914, of the total number of locomotives inspected. The number of and results from accidents have also decreased during this period, as shown by the following reportable accidents due to the failure of locomotive boilers and their appurtenances:

Year	Number of accidents	Number killed	Number injured
1912.....	856	91	1,005
1913.....	820	36	911
1914.....	516	21	574

It was believed that these figures represent the results of the inspectors and the effect of the law. The greatest trouble with accidents has been with the failure of arch tubes and four out of every five of the accidents are caused by the improper application. The careful cleaning of them is also of vital importance.

All roads should insist on a proper inspection of the locomotives before they leave the terminal, and some roads provide blanks to be filled out by the engineer for this purpose. Some difficulty is being found in having the boilers washed out properly. All wash-out plugs should be removed at every washing and the work should be done in a thorough manner. The government inspectors want to co-operate as much as possible with the railroads in correcting defects, and so far have found that most of the railroads are anxious to co-operate with them, so that it has been unnecessary as yet to file suits in the courts regarding the violation of the boiler inspection law.

#### SMOKE PREVENTION

In order to eliminate dense black smoke, three conditions must exist, viz., to supply the fire with sufficient air, to thoroughly mix the combustible gases and air, and to maintain the temperature in the firebox to cause the combustible gases and oxygen of the air to unite. It is found that inadequate draft is usually responsible for smoky chimneys; therefore it is evident that it is necessary to have a properly designed front end, including the exhaust nozzle, ample grate opening, and ashpan opening large enough to insure free access of air. Grate opening is more generally found to be restricted by clinkers than by faulty design. Trouble is sometimes caused in properly designed front ends by air leaks in the smokebox. The effort to overcome fires along the right-of-way has resulted, to some extent, in restricting the air opening in the ashpan. The ashpan openings are frequently permitted to fill up with ashes, especially in winter on account of freezing. The smaller the amounts of coal fired at a time the better the results obtained.

If heavy charges of coal are applied, there will not be sufficient air to mix with the volatile matter and the temperature of the fire will be materially reduced. The brick arch is a great aid in smoke elimination, as it increases the travel of the gases and gives them a chance to combine with the oxygen of the air before coming in contact with the comparatively cool firebox sheets. When fresh coal is applied, the steam jets, beside giving a small mixing effect, are helpful in furnishing the necessary air over the fire. They require the constant attention of the fireman, because if they are not closed after the volatile matter is burned off they will inject a surplus of cold air which will have a tendency to reduce the temperature in the firebox.

Special effort should be made to furnish a uniform grade of coal because it is hard for the best fireman to obtain the best results with a grade of coal which is continually changing. Better results will be obtained if an inferior grade of coal is furnished at all times, because where it is changed frequently the locomotive is drafted to burn the inferior grade and the better grade is wasted.

Locomotives must be maintained in good shape at all times to enable the crews to eliminate smoke. Of course this costs money, but it pays in the long run on account of the efficiency obtained when this is done. Minor defects must be looked after and there is no question but that it is a paying investment because it prevents engine failures and increases the engine mileage between shoppings.

The following is taken from a letter from F. R. Wadleigh, of the firm of Wadleigh & Osborn, consulting engineers, Philadelphia:

"The European railways pay much more attention to firing than we do; their men are more carefully instructed, the observance of proper methods is strictly enforced, and every appliance is made use of that will decrease fuel consumption. Then, they are much more particular as to sizes of coal used. For instance, on the French railways, each class of service has its locomotive fuel carefully divided as to lump and slack or briquettes and slack by weight; passenger service uses 20 per cent slack and 80 per cent lump or briquettes; fast freight 40 per cent slack; yard engines, 80 per cent slack.

"The through trains of France and Germany run further without stops than do our trains, which is a factor in fuel economy and smoke prevention. The longest non-stop run in Germany is 106 miles at 44 miles an hour, while in France the longest is 203 miles at 47.6 miles an hour."

The report is signed by Martin Whelan, chairman, A. M. Bickel, P. K. Sullivan, W. A. Heath, and B. J. Feeny.

#### DISCUSSION

The substance of the discussion of this subject was a statement made by John McManamy to the effect that a properly designed engine with a properly instructed engine crew is necessary if smokeless firing is to be obtained. Without a properly instructed engine crew the beneficial effects of the various smoke eliminating devices will not be fully realized. The proper opening in the ash pan is believed to be from 90 to 100 per cent of the tube area and the opening through the grates should be as large as consistent with good grate design. A. G. Kinyon believed it should not be lower than 46 per cent of the total grate area, and cases were cited where as much as 56 per cent had been obtained. At all events atmospheric pressure should be maintained in the ashpan. The representative of one road stated that a saving of 20 per cent in fuel had been obtained in increasing the ashpan opening.

One shovel at a firing was recommended by most of the members, and in order to encourage the firemen to follow this practice the fire door should be properly hung and maintained, so that it can be operated with the least amount of effort. A member from the Buffalo, Rochester & Pittsburgh spoke of the smoke box damper that is applied to 50 per cent of the locomotives on that road. This damper controls the opening by the deflector

plate and has three positions—open, partly open and closed. This has been found to permit of fuel economy, especially when the engine is drifting or at rest, and in long hard drags where the damper can be used to decrease the full force of the draft which would tear holes in the fire. This arrangement was described in the Railway Age Gazette of February 14, 1913, on page 297. The brick arch and steam jets were spoken of as giving great assistance in smoke elimination.

#### MECHANICAL STOKERS

The advantage to be derived from stoker firing of locomotives is the ability to fire the engine continually up to its capacity, and it is found that the stoker-fired locomotive can either take the same tonnage as the non-stoker over the road in less time, or a larger train can be handled in the same time. As a concrete example of this fact we note that in a recent test for the capacity of locomotives a stoker-fired engine was operated for six hours, firing an average of 7,800 lb. of coal per hour, which means a continual capacity of the locomotive firing in excess of that which could be maintained by hand firing.

It has also been demonstrated that mechanical stokers have permitted the enlarging of the exhaust nozzle. The principal reason that permitted the increasing of the nozzle is the keeping of the fire-doors closed, thus preventing the inrush of cold air which takes place when doors are opened for hand firing. Other advantages are obtained by not opening the fire-doors, viz.: doing away with the glare or dazzling light which is produced after dark and which makes the observation of signals more difficult. It also prevents sudden change in firebox temperature which produces contraction of sheets and tubes.

A properly adjusted mechanical stoker will reduce the use of a firehook or rake on the fire bed, as the distribution of coal can be regulated to prevent banking. This is an advantage, as the frequent use of the rake disturbs particles of fuel which are carried by the draft onto the brick arch or lodged in the tubes, reducing the draft and the heating surface, and causing loss of fuel. The application of the stoker has proved to be a benefit from the standpoint of smoke abatement and there are some stoker locomotives at present being used in the heavy transfer service within the limits of large cities, resulting in practically complete elimination of smoke. Although all types of stokers are not showing an improvement in smoke prevention, the good results of some types indicate that future developments may be expected to produce good results along this line.

The firemen engaged in stoker firing do not have to devote as much time and attention to the use of the methods employed in hand firing, but are required to operate the mechanical stoking machine which furnishes them with a practical experience in the care of steam driven machinery. This mechanical education should greatly aid in the development from fireman to locomotive engineer.

The report is signed by W. J. H. De Salis, Chairman, S. V. Sproul, O. E. Whitcomb, T. B. Bowen, O. B. Capps, T. B. Burgess, H. F. Hensen, and A. L. Lopshire.

#### DISCUSSION

All members who have stoker engines on their lines reported that they have been found very successful, especially from an operating standpoint. Numerous cases were mentioned where it had been possible to increase the tonnage by the adoption of the locomotive stoker. Much better service is obtained from the crew of a stoker engine and the number of firemen required has been materially reduced on those roads having a number of stokers in service. However, a mechanical stoker cannot be allowed to make failures, as it is extremely difficult to build up a fire by hand when a stoker fails, without allowing the steam pressure to drop an appreciable degree, as the fire the stoker carries is so light.

The Baltimore & Ohio has increased the efficiency of their en-



gines on the second division between Brunswick & Cumberland 15 to 20 per cent by the use of a large number of stoker engines. It was stated that the stoker engines on that road are as economical as the hand fired engines in regard to fuel. On this division no train has been delayed 5 minutes on account of the locomotive for 45 days prior to September 15. Results of tests read by E. A. Averill of the Standard Stoker Company, showed that the stoker maintained an average evaporation of 6.52 lb. of water per pound of dry coal whereas the hand fired engines averaged 6.37 lb. water per pound of dry coal, the tests being comparative in every respect.

Another big advantage mentioned for the stoker was that when once adjusted it was not necessary to rake or hook the fire, several instances being mentioned where stoker engines had made their full trips without having the fire door opened. A Hanna stoker on the Carolina, Clinchfield & Ohio has run in pusher service for 30 days without a hook being put in the firebox. Mr. Averill mentioned a record of 8,310 miles, over two months' service, on the Norfolk & Western where the fire had not been hooked. It was pointed out that a cheaper grade of fuel could be used on a stoker engine, but several members have found that it can be too poor. Tests on the Baltimore & Ohio have shown that nut, pea and slack, a gas coal mixture, gives better results than run-of-mine and slack.

The stoker firemen have less real hard work to do and find more time to study for the progressive examinations for engineers. They also receive a training in the handling of machinery that better fits them for the position of engineer.

#### LOCOMOTIVE BRAKE EQUIPMENT

The care of locomotive brake equipment on the road is something in which the engineman, trainman and car inspector is concerned. The compressor, being the source of supply for the air brake, signal system and other air operated devices, should be given the most attention. In starting the compressor, always run it slowly until it becomes warm, and with drain cocks open, allowing the condensed steam to escape in order to provide an air cushion. The lubricator should not be started until all condensation has escaped and the drain cocks are closed. Then start the lubricator and feed in ten or fifteen drops quickly, after which regulate the feed to the amount desired while the compressor is running. Particular attention must be given the high pressure air cylinders of compound compressors, as to oiling, as the cylinder is liable to become overheated if neglected, on account of the two stage method of compression.

Compressors should be shut off when cleaning the fires, or dumping the ashpans, except on engines equipped with an air operated reverse gear, or where the engine might move on grades. The brake pipe leakage should not be over five pounds per minute. The engineman should from time to time note the increased compressor labor necessary to operate the engine brakes, and the various air operated devices on the locomotive; if the labor is abnormal, the leaks should be located and repaired.

The main reservoir should be drained every day. It is very important at any time, but more particularly so in freezing weather. The accumulation of moisture in the main reservoir is hastened by any steam leaks around the compressor, particularly from piston rod packing or from any portion of the boiler where the rising steam can reach the air inlet.

When leaving an engine under steam outside the roundhouse in freezing weather, the brake pipe and signal line stop cocks at the rear of the tender should be opened, and the compressor run slowly—just fast enough to maintain circulation through the air pipes, but not fast enough to cause the pistons to strike the cylinder heads. Triple valves, distributing valves, drain cups, etc., should be drained daily. The practice of using the automatic brake valve in emergency in handling light engines, or in switching, should be discouraged.

The engineman should school himself in observing the gage

frequently to guard against the pressure becoming too high, or leaking away unnoticed. He should also watch the gage during brake operations to note the effect of the brakes. The incoming engineman should make a thorough inspection, reporting the needed repairs, and the outgoing engineman should, before leaving the vicinity of the roundhouse, determine whether the apparatus is in proper condition to make the trip.

Much of the information necessary to properly report the condition of the various parts of the brake and signal system can be obtained before the terminal is reached, remembering that the man operating the equipment is in a better position to determine defects by its erratic action than is the machinist who will probably make repairs while the locomotive is dead in the roundhouse, but should the engineman be unable to definitely locate any defects manifested he should describe on the report book the manner in which the defective apparatus operates.

The care of locomotive brake equipment at terminals is most important in order to reduce the liability of failures resulting in delays on the road. Inspectors and repairmen should be

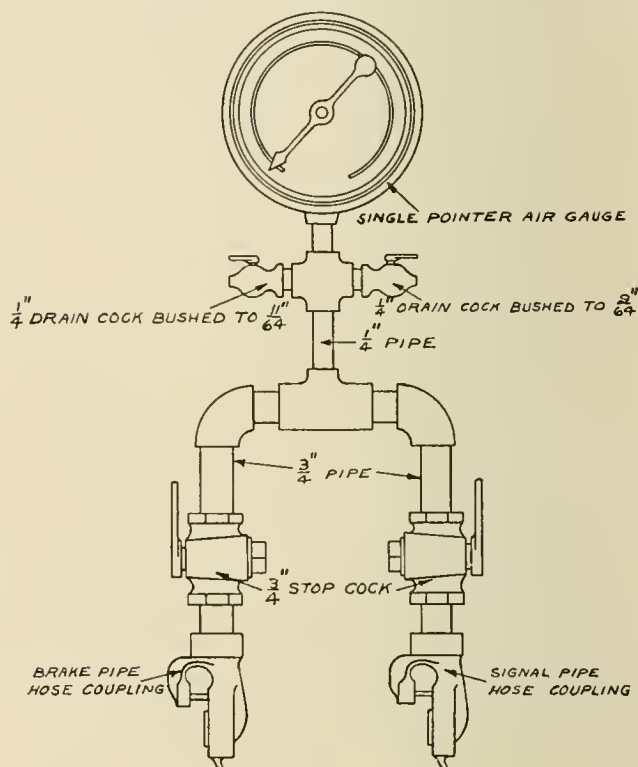

NOTE: MAKE AS COMPACT AS POSSIBLE.

Testing Device for Locomotive Brakes

provided at the principal terminals on all divisions, to inspect, test and repair air brake equipment on locomotives. This should include the complete equipment from the compressor to the brake shoes.

The practice of merely noting that the compressor accumulates pressure in the main reservoirs, without considering volume or time, and that the brake applies and releases, is not sufficient under modern operating conditions to insure against delays after leaving the roundhouse. Hostlers should be required to open the main reservoir drain cocks, also the compressor drain cocks when the engines are placed in the roundhouse.

Air gages should be tested and compared with a master gage at least every 90 days. No freight or passenger engine should leave the roundhouse without the brake and signal system being thoroughly tested out, and all defects corrected. The foundation brake gear on locomotives and tenders should be given such attention as will insure the proper length of rods, levers and piston travel being maintained, to equally distribute the braking power, and to maintain the braking power at its maximum.

Worn rods, levers, hangers, pins, keys, etc., should be renewed before they fail.

Tenders on modern locomotives are heavier, when loaded, than the locomotive itself of a few years ago, weighing in some instances over 100 tons. It is necessary then that the braking power be maintained at its maximum in order to reduce draft gear strains, liability of wheel sliding and to provide smooth handling of trains as far as possible.

Enginemen should in no way be relieved of responsibility for properly inspecting and caring for brake apparatus while in their charge, or for properly reporting all existing defects on arrival at terminals. All defects should be reported by incoming enginemen on work book or forms as provided. Defects found by inspectors should be reported on forms or slips, and delivered to foremen or repairmen, a record being kept.

The committee is unanimously of the opinion that the brake equipment should be taken care of by repairmen at terminals, they to make such tests and inspections as will disclose any defects, and correct them without waiting for the enginemen to report them. Along these lines the assistant to the vice-president (in charge of mechanical matters) on one of our large railroads issued instructions that the compressors and other brake equipment on freight and passenger locomotives should be tested each trip before the locomotive left the roundhouse for the train. In order that the inspectors might know how extensive their work of testing out the brake and signal systems should be, they were provided with a code of tests, and were instructed that all defects must be corrected before the locomotive left the roundhouse. They were also provided with a sketch showing a simple test device that could be assembled quickly and cheaply at any terminal, made up of the ordinary fitting usually found in storehouses.

The object of making these tests before the locomotive went to the train was to maintain the locomotive brake in condition to avoid as far as possible failures and delays, and it has resulted in compressor failures being reduced from 231 in 1912, to 123 in 1913. These failures are the result of all the defects that compressors are subject to, and of delays ranging from five minutes to total failures, or giving up trains.

The best results are obtained in lubricating the air cylinders of duplex pumps by using a good grade of valve oil (not superheat valve oil) in an automatic oil cup. At important points the air brake repairman should keep on hand several automatic oil cups and air strainers. The oil cups and air strainers removed should be placed in lye and boiled out. Keeping the intake to the air strainer clear is of the utmost importance, as a slightly clogged strainer will greatly reduce the capacity of the pump when the speed is at all fast.

When pumps are equipped with auxiliary air cylinder oilers, which are connected with the main lubricator in the cab, oil should be supplied intermittently. The amount of oil to be used at one oiling and the time between oilings should be governed by the requirements of service. When superheat valve oil is used in the main lubricator, the standard automatic oil cup should be used instead of the auxiliary air cylinder oiler. Care should be taken not to use more oil in the cylinders than is necessary, as too much oil clogs the valves and passages and lessens the pump capacity. A swab well oiled is essential on the piston rod.

[The report also contained complete detailed instructions for the testing and care of the air brake equipment.]

The report is signed by G. H. Wood, chairman, B. Hyanes, R. E. Anderson, W. V. Turner and E. Bales.

#### DISCUSSION

It was pointed out that although the air brake was a dividend producer in the matter of permitting a greater density of traffic if it is not properly maintained it could be made very expensive for a railroad. Extra parts of the air brake should be kept in stock in good condition, so that they may be readily used in replacing defective parts. This will permit of taking the de-

fective parts to the shop, where they can be repaired properly. It pays to keep the air brake in its proper condition. Special care should be taken to see that the centrifugal dirt collectors are properly cleaned. The engineers should be encouraged in reporting every defect to the air brake equipment. The traveling engineers should be so familiar with the air brake that they will be able to answer any question the engineers may ask. On the Santa Fe the traveling engineers are required to have a clear understanding of the air brake. Mr. Wood in his closing remarks laid particular stress on the importance of maintaining the feed valve with No. 6 E T equipment in perfect condition to prevent the engine brakes creeping on.

#### EFFICIENT OPERATION OF LOCOMOTIVES

Realizing the innumerable angles from which this subject might be reviewed, and the varying conditions surrounding locomotive operation, the committee has sub-divided the original subject into nine parts.

*Assignment of Power.*—To obtain maximum efficiency at minimum cost the matter of assigning power should be made with due consideration of both operating and mechanical points of view, observing not only the physical condition of the roadbed and bridges, the capacity and fitness of terminal facilities for the care, up-keep and turning of the power assigned, but also its adaptability to meet the requirements of service, either freight or passenger, taking into consideration the weight and schedule of trains.

*Classified Repairs.*—The cost involved by the early shopping of power may be an item of profit or expense depending largely upon the general condition of the engine and the service required, also the demand for power. In some cases badly worn engines may successfully and efficiently fill a requirement provided the work is sufficiently light. The most profitable time for shopping power depends largely on local conditions. Density of traffic in some localities with many high class freight trains, and other important traffic with an increasing public demand for better service, would not warrant the working of power in other than first class condition, while branch lines, unimportant freight or switch service, may provide suitable places to obtain additional wear from locomotives between shoppings.

Power received from the general repair shops after overhauling should be known to be in perfect condition before being returned to the operating department for service. The power should be well broken in before it is placed in its regular service. Attention is called to the increased cost of operation where scale is allowed to accumulate on the tubes or boiler shell, causing an increase in fuel consumption, an increase in the use of steam by excessive use of the blower and in some cases leaky tubes or firebox sheets which result in engine failures or delays.

*Boiler Attachments.*—Location of all boiler attachments for safety, accessibility and convenience of operation and repairs, is a matter which may appear to some to be of small importance yet may involve great expense. An injector or lubricator placed beyond the convenient reach of the engineer does not receive the attention and fine adjustment that economical service would demand, or that it might receive if properly placed. Sander valves, hydrostatic flange oilers and other boiler attachments are equally important.

The best results are obtained by locating the lifting injector with the center line of the injector on a line with the top of the tank whether placed inside or outside of the cab. The non-lifting injector is mounted below the bottom of the tank and is usually placed on a bracket mounted on the tail piece of the engine frame. A safer application (where it is possible) is to mount the injector on a bracket suspended from the bottom of the mud ring. This would place the injector pipes under the same influence of expansion and relieve the strain from the steam pipe and connections.

If a regular feed of water to the boiler is maintained the steam pressure is more easily maintained and the liability of





Locomotives may be kept in perfect condition at great cost, may be operated and fired 100 per cent perfect, loaded to full tonnage capacity, yet fail in good returns. The matter of hauling empty or half loaded cars of great weight and size increases operating expenses and proportionately reduces net returns, and therefore, should be a matter of mutual concern to every railroad in the land.

The report is signed by J. R. Scott, chairman, P. J. Miller, J. J. McNeil, W. L. Robinson, C. W. Hyde, F. W. Edwards, M. H. Haig and W. G. Tawse.

#### DISCUSSION

It was believed that too much attention could not be given the proper and convenient location of the various appurtenances in the locomotive cab so that the engineer may operate his engine with the least possible effort. Regarding the use of flange oilers some members stated that they had trebled the life of the tires and in some cases they had eliminated trouble from derailments.

The subject of superheaters was again very thoroughly discussed. The members were cautioned to keep the superheater flues clean and not to carry the water too high in the boiler if the best results are to be obtained. The wide open throttle and regulation by the valves was strongly recommended up to the point where it would be impractical to further shorten the cut-off, when of course the regulation should be done by the throttle. The throttle should always be slightly open when drifting unless other means are provided to take care of the cylinder lubrication. The Erie has eliminated the drifting valve entirely, so that it is now necessary for the enginemen to open the throttle slightly.

The question of pooled engines vs. regularly assigned engines was thoroughly discussed. The members were very strong in their approval of assigned engines. A member from the St. Louis & San Francisco stated that with the regularly assigned engines there was an average of 18,000 miles per engine failure in a recent six-months' period, as against an average of 6,000 miles per engine failure when the pooled system was in effect. He also stated that by changing from the pooled system to assigned engines there had been a decrease of 6 per cent in fuel used with an increase in tonnage hauled of 2.33 per cent. It was believed that in nearly all cases the engineers would take better care of their engines, and numerous cases were mentioned where the mileage between shoppings had been increased by adopting the assigned engine plan. While more engines are needed than with the pooled system it was believed that the additional investment would be warranted.

#### PRACTICAL CHEMISTRY OF COMBUSTION

Alonzo G. Kinyon, superintendent of locomotive operation, Seaboard Air Line, presented an interesting lecture on the chemistry of combustion, illustrating his remarks by chemical experiments and lantern slides. He stated that burning is the rapid chemical combination of anything with oxygen and the heat and light are the result of burning. It was explained that matter was divided into two classes, elements and compounds, the elements being defined as matter in its simplest form and compounds as substances that could be subdivided into elements.

A series of experiments was then performed to show that chemical changes were brought about by two general processes. Where two or more elements are brought together and combined, forming a compound, there is a building-up process which produces heat. Where a compound is treated chemically and separated into its elements, there is a tearing down process which absorbs heat. In burning the coal in the firebox it is necessary first to split the compound (coal) into its elements, thus producing a tearing down process which absorbs some of the heat from the fire. This is followed by a building up process in which the oxygen of the air combines with the fuel elements of the coal and burns, producing heat.

As an illustration of the tearing down process, a small quan-

tity of red oxide of mercury was placed in a test tube. Upon the application of heat the oxygen or gas was driven off, leaving globules of mercury deposited on the inside of the tube. The presence of oxygen as it was driven off was demonstrated by taking a match with a small ember on its end and placing it in the end of the test tube. As soon as the oxygen came in contact with it, it started to glow brightly.

In demonstrating the building up process, a piece of magnesium ribbon was ignited and as it burned, giving off heat, a compound (magnesia) was formed in the shape of a powder, caused by the combination of the magnesium with oxygen. Another interesting experiment illustrating the production of heat was made by placing a small amount of sugar in a glass jar to which was added a small amount of sulphuric acid. There was an immediate change in the color and the bulk of the material in the glass, and a very noticeable amount of heat was produced.

Oxygen ignites with different elements at different temperatures, 1,800 deg. F. being necessary to burn the volatile gases in coal. The carbon in the coal will burn at 914 deg. F., and as the firebox temperature is usually about 2,300 or 2,500 deg. F. the main point is to get plenty of oxygen into the firebox. Without sufficient oxygen the heat loss is considerable, for when the carbon in the coal is not completely burned it passes off as carbon monoxide gas, which gives off only 4,500 B. t. u., whereas if it was completely burned to carbon dioxide it would give off 14,600 B. t. u., a B. t. u. (British thermal unit) being the heat necessary to raise one pound of water at 39 deg. F. one degree in temperature. The complete combustion of the carbon is further hindered because the hydro-carbon gases absorb the oxygen more readily than the carbon, so that the carbon has to depend on the oxygen that is left. Mr. Kinyon also showed some lantern slides on the proper methods of firing.

#### SPEED RECORDERS

Fred Kirby (B. & O.) presented a paper on speed recorders which was in part as follows:

We have in use on the railroads of the United States the following recorders: Boyer, Flaman, Hausshalter and Railway; and on some of the private cars we have what is known as the Hutchinson Electric and the Warner. The Boyer, Flaman and Hausshalter are the principal recorders used on locomotives and trains. The Boyer and the Flaman are more generally used on locomotives, and the Hausshalter is principally used on cars. The Hausshalter recorder is purely a mechanical device, the main shaft of which revolves only about 45 revolutions per mile, and when placed on a locomotive it enables the engineer to note at a glance the speed at which he is running, and besides records on the record tape the following information: Speed at all times from zero to 100 miles per hour; time of all stops; time between stops; time from start to finish of run; distance between stations or stops, and distance of run (total length).

It is also fitted with an alarm bell which can be set to ring automatically when any desired speed per hour is attained. The time-recording feature of the Hausshalter apparatus is a very valuable one, particularly from the engineer's standpoint, as it proves without a doubt the time of all detention and station stops and the distance from the starting point at which they took place, which shows up the train dispatchers and station men when they are at fault, as well as slow movement on the part of tram crews.

The Boyer speed recorder is an oil pump arrangement and the main shaft turns about 540 revolutions per mile, and gives practically about the same information as all other recorders.

There are two devices called the electric annunciator that can be attached to speed recorders of any type that are not provided with the alarm bell. They consist of an attachment fitted to the machine itself with an electric bell, one or more dry cell batteries, and the required amount of insulated copper wire;





It will be seen that it is fitted with a non-return valve so that the water cannot run back through the steam pipe. In addition to the connection to the exhaust steam passage, provision is also made for carrying any superfluous steam generated

arrangement is provided so that the hottest feed water, which, of course, will be near the upper surface in the tank, is drawn by the pump.

Another device fitted to this locomotive is an air operated clutch on the lift shaft of the valve gear. The valve gear is of the Stevenson type with a screw reverse mechanism and this clutch is fitted to the shaft for the purpose of steadying the motion and relieving the reach rod. The reversing screw bracket combines, with the screw, an air cylinder and piston for the purpose of assisting the operation when lifting the link and the air control valve for the clutch is interlocked and connected with this cylinder. The clutch also has an arrangement for control independent of the reverse.

The cylinders of these locomotives are fitted with a new type of combined vacuum and water relief valve, which is also shown in one of the illustrations. One of these valves is

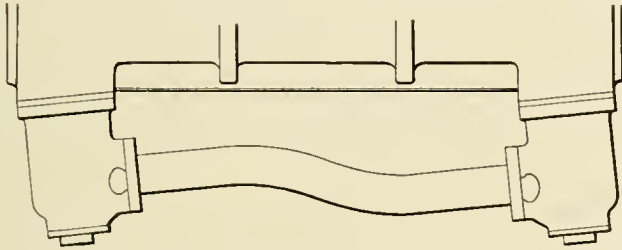

Application of Vacuum and Water Relief Valve

tion to the connection to the exhaust steam passage, provision is also made for carrying any superfluous steam generated

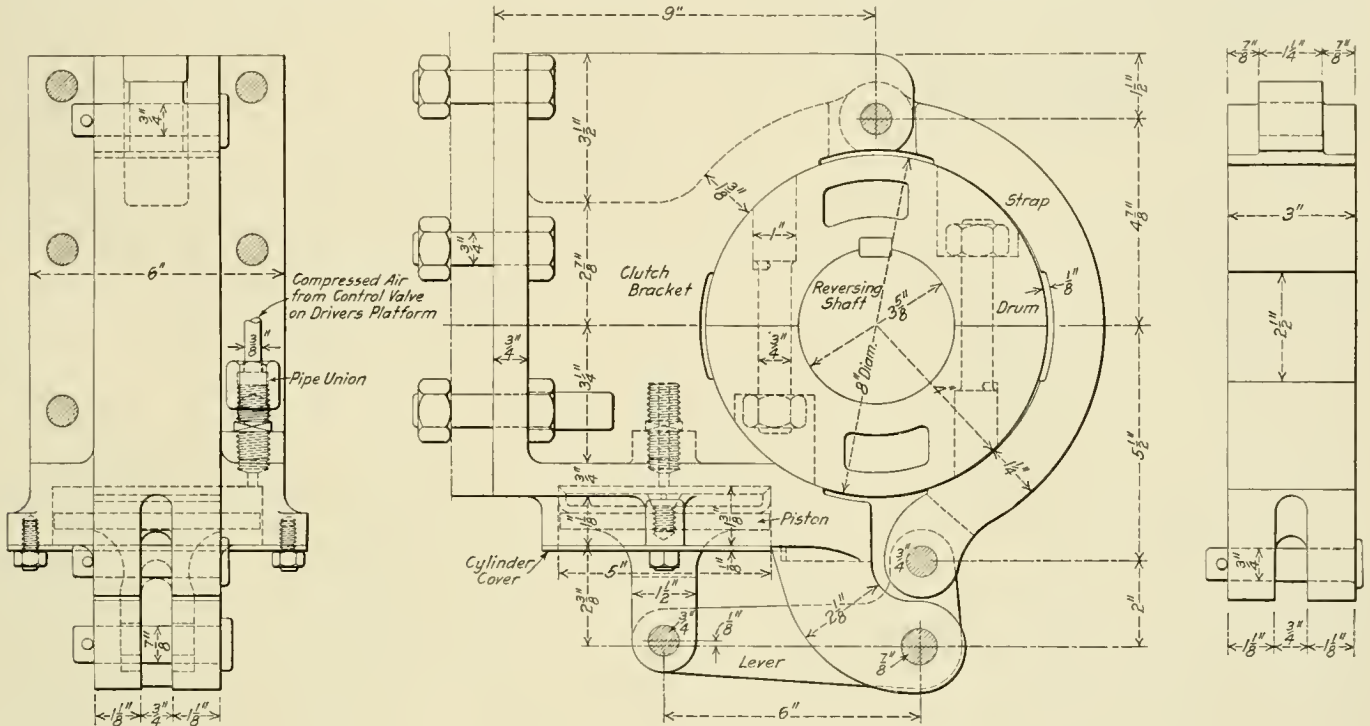

Clutch for Reversing Shaft

in the boiler, to the water in the tender, instead of allowing it to blow off at the safety valves.

While the feed pump handles the boiler feeding normally,

placed at the bottom of each end of the cylinder barrel. The construction and operation of the apparatus will be clear from an inspection of the illustration.

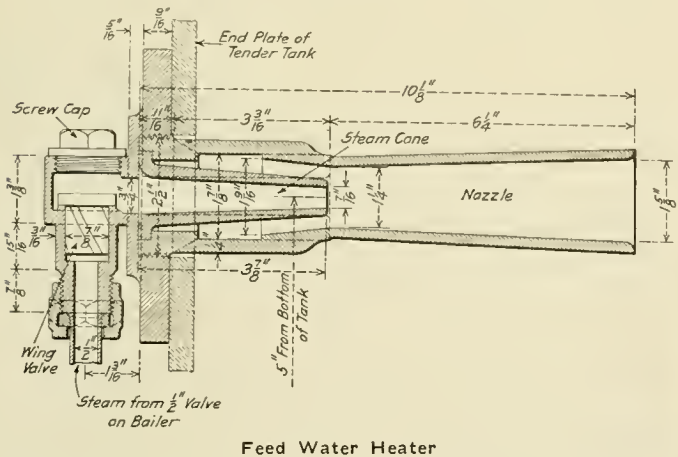

Feed Water Heater

### METAL PILOT ON THE LEHIGH VALLEY

A short pilot has been developed on the Lehigh Valley which is neat in appearance and very simple in construction. It has a metal frame built up of flat bars and angles, with slats made of

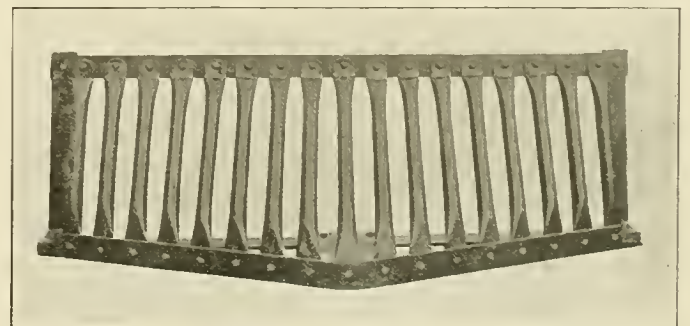

Simple Short Pilot Now Used on the Lehigh Valley

a combination (hot water type) injector is also fitted to the back head of the boiler to act as an auxiliary. A float feed



scrap flues two inches in diameter. The construction is shown in one of the illustrations. It has been in use for some time with highly satisfactory results.

The all-metal long pilot, which was formerly used by the

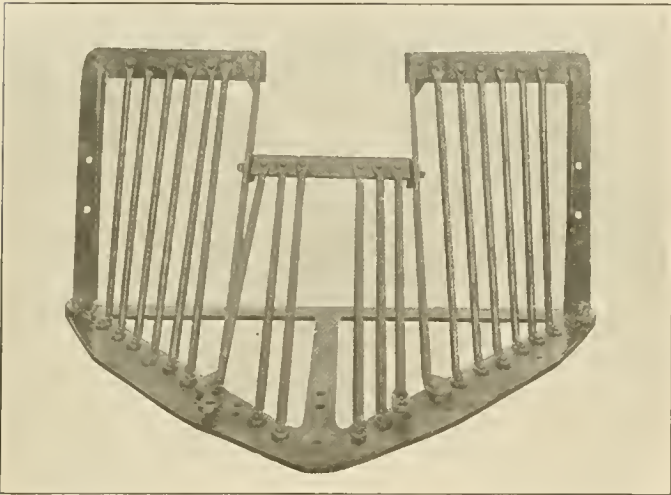

Long Nosed Pilot Formerly Used on the Lehigh Valley

Lehigh Valley, is also shown in one of the illustrations. This pilot weighed 586 lb. and cost \$27.58. The short pilot weighs 262 lb. and can be built at a cost of \$5.47.

### RINGLEMAN SMOKE CHART

The following notes concerning the construction of the Ringleman smoke chart and the methods of taking smoke readings are from Appendix III of Bulletin No. 8, entitled "Some Engineering Phases of Pittsburgh's Smoke Problem," issued by the University of Pittsburgh.

A rule by which the cards may be produced is given by Prof. Ringleman as follows:

- Card 0. All white.
- Card 1. Black lines 1 mm. thick, 10 mm. apart, leaving spaces 9.0 mm. square.
- Card 2. Lines 2.3 mm. thick, spaces 9.0 mm. square.
- Card 3. Lines 3.7 mm. thick, spaces 6.3 mm. square.
- Card 4. Lines 5.5 mm. thick, spaces 4.5 mm. square.
- Card 5. All black.

These lines and spaces are so arranged that the black covers respectively 0, 20, 40, 60, 80 and 100 per cent of the white surface of the card. These percentages are graded for convenience as smoke numbers 0, 1, 2, 3, 4 and 5, so that number 0 signifies no smoke or a clean stack; and number 4 signifies a stack which is emitting an 80 per cent black smoke, or for convenience the percentage of black smoke can be obtained by multiplying the smoke number by 20 per cent.

In making observations of the smoke proceeding from a chimney, the six cards are placed in a horizontal row and hung at a point 50 ft. from the observer, and as nearly as possible in line with the chimney. At this distance the lines become invisible, and the cards appear to be of different grades of gray, ranging from very light gray to almost black. The observer glances from the smoke coming from the chimney to the cards which are numbered from 0 to 5; determines which card most nearly corresponds to the color of the smoke, and makes a record accordingly, noting the time. Observations should be made continuously during, say, one minute, and the estimated average density for that minute recorded, and so on, records being made once each minute. The average of all the records made during the period of observation is taken as the average figure for the smoke density.

To determine the per cent of black smoke, or average density, the following rule was followed: Percentage of density equals smoke units  $\times$  0.20 divided by stack minutes.

## DEVICE FOR FEEDING BOILER COMPOUND

BY F. W. DUNNING

The illustration shows a simple device for introducing soda ash, barium hydrate, or other compounds, into stationary boilers, which is used at the power house of the Wheeling & Lake Erie at Brewster, Ohio. It is well known that the introduction of some compounds, such as soda ash, into the feed water is liable to cause a deposit to accumulate on valve seats and other parts of the pipe line leading to the boilers. This device may be located between the feed pump and the boiler, thus causing the treating solution to affect a minimum length of pipe.

Before charging the container, the soda ash or other compound should be dissolved in a pail of hot water. The 1 in. cut-out cock and the  $\frac{3}{4}$  in. globe valve are then closed and the 2 in. gate valve and  $\frac{3}{8}$  in. drain cock are opened, the latter draining the container of water. The  $\frac{3}{8}$  in. drain cock is then closed and

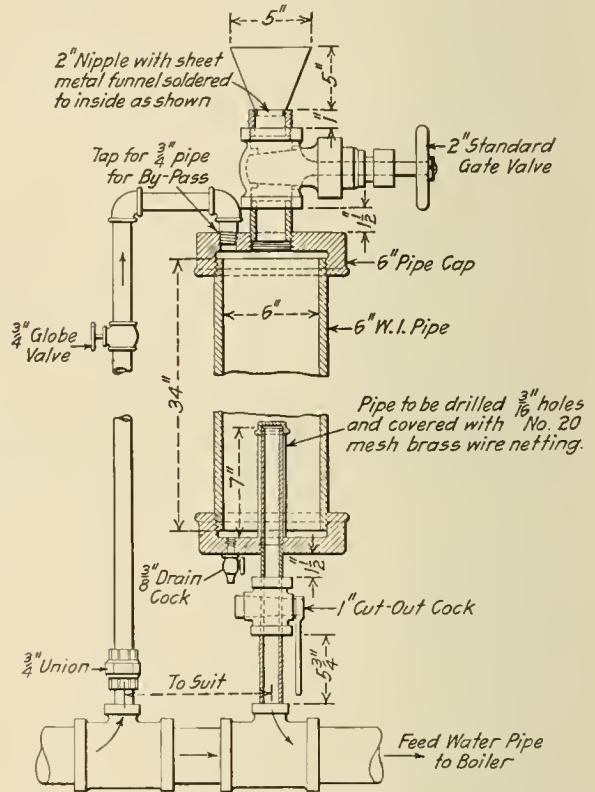

Device for Introducing Soda Ash Into Feed Water of Stationary Boilers

the container is filled with solution through the sheet metal funnel; the device is put in operation by closing the 2 in. gate valve and opening the  $\frac{3}{4}$  in. globe valve and the 1 in. cut-out cock. The solution gradually flows through the cut-out cock into the feed water pipe and thence to the boiler. The rate of flow is regulated by means of the  $\frac{3}{4}$  in. globe valve.

This device has been used to feed soda ash into four 450 horsepower Babcock & Wilcox boilers for several years. No repairs have been necessary and the boilers have been quite free from scale.

USE OF ELECTRIC VEHICLES.—Dr. Charles P. Steinmetz, of the General Electric Company, is credited with the prediction that within ten years there will be in operation not fewer than 1,000,000 moderate-priced electric vehicles whose approximate price will not exceed \$500, with a speed certain to average 20 miles per hour.—*American Machinist.*

# CAR DEPARTMENT

## STEEL UNDERFRAMES FOR USE ON WOODEN FREIGHT CARS

A type of steel underframe for application to wooden freight cars has been developed at the East Buffalo car shops of the New York Central & Hudson River and is being extensively applied to wooden cars on the New York Central Lines. It has proved economical in application and the cars equipped with it are giving good results in service. The design is varied to suit the different types of cars, the two shown in the engravings being for box cars and gondola cars.

While the structure might not be termed by some a complete underframe it is sufficient to place the wooden cars to which it is applied in the steel underframe class. The old wooden sills are all retained, as are the truss rods, a reference to the illustration showing the queen posts and truss rod supports. The body bolsters used on the wooden underframe, are, however, entirely removed. As will be seen by reference to the frame used on box cars, this consists of two center sills with top and bottom cover plates, two body bolsters and two needle beams. The center sills are 9 in., 25 lb. channels and extend the full length of the car, there being a casting connecting them against which the wooden end sill seats. The center sills are placed back to back

is a  $\frac{1}{2}$  in. plate, 20 in. wide for a distance of  $18\frac{1}{2}$  in. or the width of the center sill cover plate, and tapering to 10 in. at both ends. Filler castings are used between the center sills and also from the center sill to the outer edge of the car while there is a 10 in. by  $\frac{3}{4}$  in. bolster tie plate at the bottom extending across the

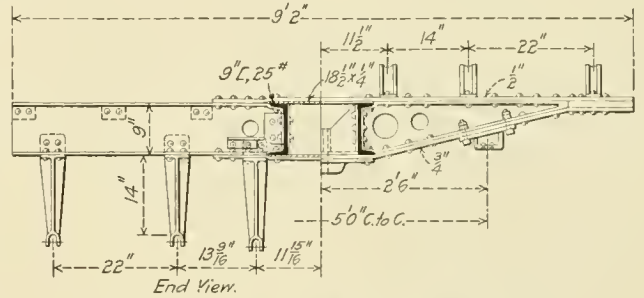

Cross Sections of the Box Car Underframe

car; the center bearing is riveted to this tie plate. Each of the needle beams consists of two 9 in., 15 lb. channels connected to the center sill and extending to the outside of the car. A needle beam tie strap passing above the top center sill cover plate and riveted to the center sills and the needle beam channels connects

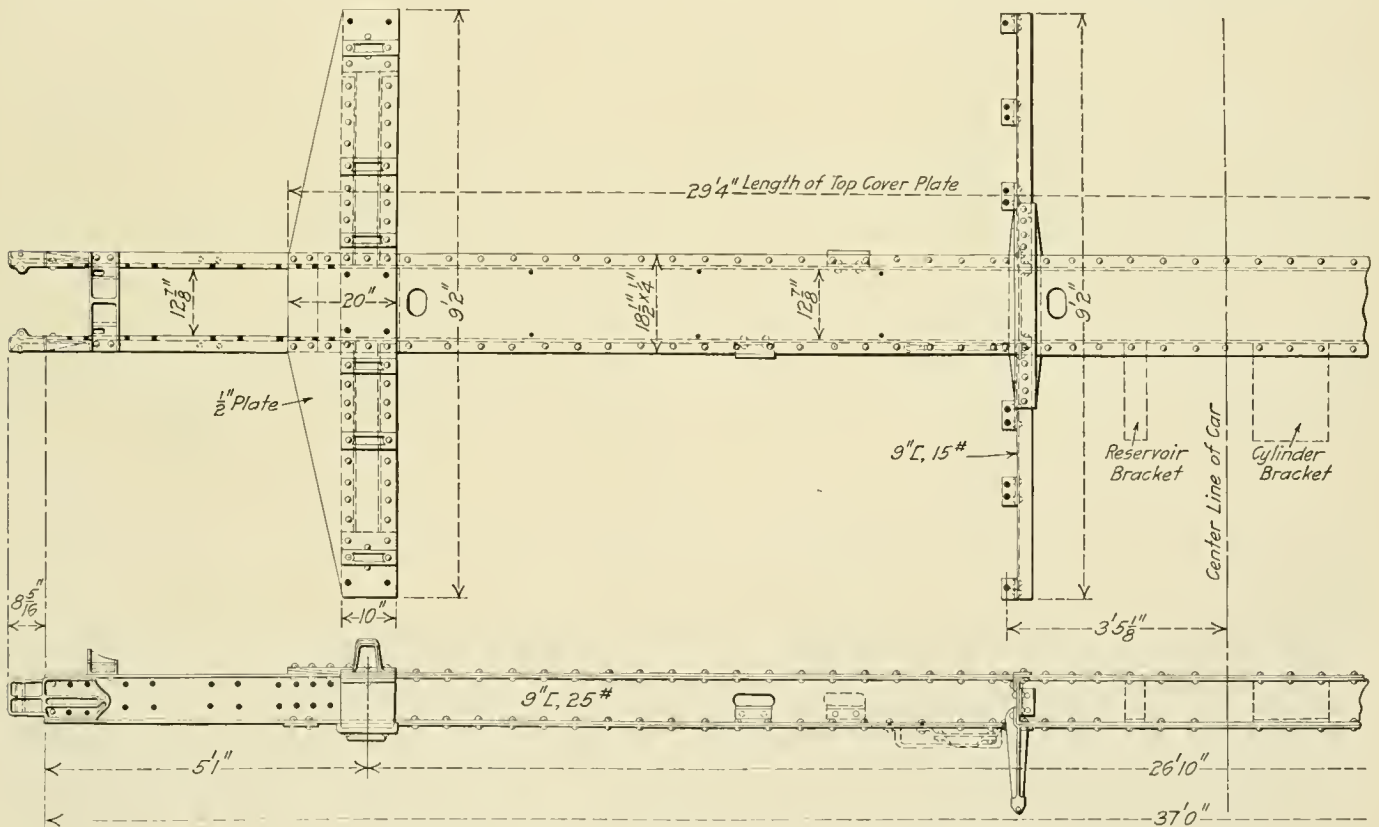

New York Central Steel Underframe for Application in Repairing Wooden Box Cars

and spaced  $12\frac{7}{8}$  in. apart. The top cover plate is  $18\frac{1}{2}$  in. by  $\frac{1}{4}$  in. and is 29 ft. 4 in. long, extending under the bolster cover plate and ending at the outer edge of the latter. The bottom cover plate is also  $18\frac{1}{2}$  in. by  $\frac{1}{4}$  in. but is only 25 ft.  $11\frac{1}{4}$  in. long, ending just back of the body bolster.

The body bolster has a top cover plate extending the full width of the car and passing over the center sill top cover plate. This

them at the top; this plate is 3 ft.  $3\frac{3}{8}$  in. by 4 in. by  $\frac{1}{2}$  in. At the bottom a similar cover plate of the same length is used. This plate is 6 in. by  $\frac{1}{2}$  in. where it passes under the bottom center sill cover plate and tapers to 4 in. at the ends. A center sill stiffener,  $8\frac{3}{4}$  in. by  $\frac{3}{8}$  in., is used between the center sills at each needle beam.

The details of the underframe for use on gondola cars are sim-



ilar to those of the box car underframe. The center sills are 9 in., 25 lb. channels extending the full length of the car and spaced 127/8 in. back to back. The top cover plate is 18 1/2 in. by 1/4 in., and is 28 ft. 4 in. long, extending between the outer edges of the bolster cover plate and passing under the latter.

center sills are 37 ft. over all and those on the gondola cars are 36 ft. over all.

### SAVING CAR DAYS

O. C. Castle, car service agent of the Sunset-Central Lines, has issued a bulletin on the subject of "Saving Car Days," giving figures to show that during the fiscal year 1914 the system made a saving in car hire balance of \$430,865, a daily average saving of \$1,180, or the equivalent of 2,622 car days. The average mileage per car per day for all cars on the line increased from 20.4 in 1912-13, to 21.9 in 1913-14, while the movement of foreign cars increased from 21.4 to 28.6 miles per car per day. The bulletin states that these results were accomplished by eternal vigilance and persistent "plugging" on the part of hundreds of loyal employees in the campaign to save car days; and it urges all the employees and the officers to continue their efforts in this direction. The bulletin concludes with the following:

"From the present unsettled outlook, due to the European war, the company is going to need every 'car day' we can put away in our savings banks.

"Let's watch the little car days, and make the slogan 'Save the Car Days' next in importance to 'Safety First.'

"I'll be glad to get a note from any one any time, telling how

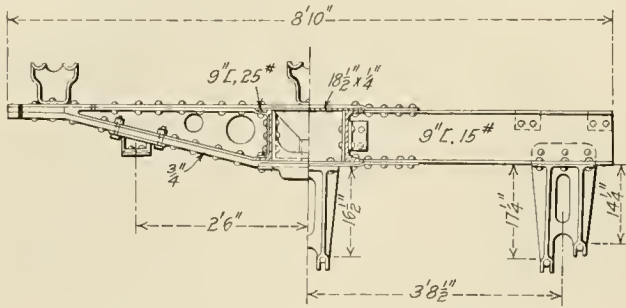

Cross Sections of the Gondola Car Underframe

The bottom cover plate is 18 1/2 in. by 1/4 in. by 24 ft. 11 3/4 in., ending just back of the body bolster. The needle beams are 9 in., 15 lb. channels with a center sill filler plate and connecting tie straps top and bottom.

In the gondola cars there are used four corner braces con-

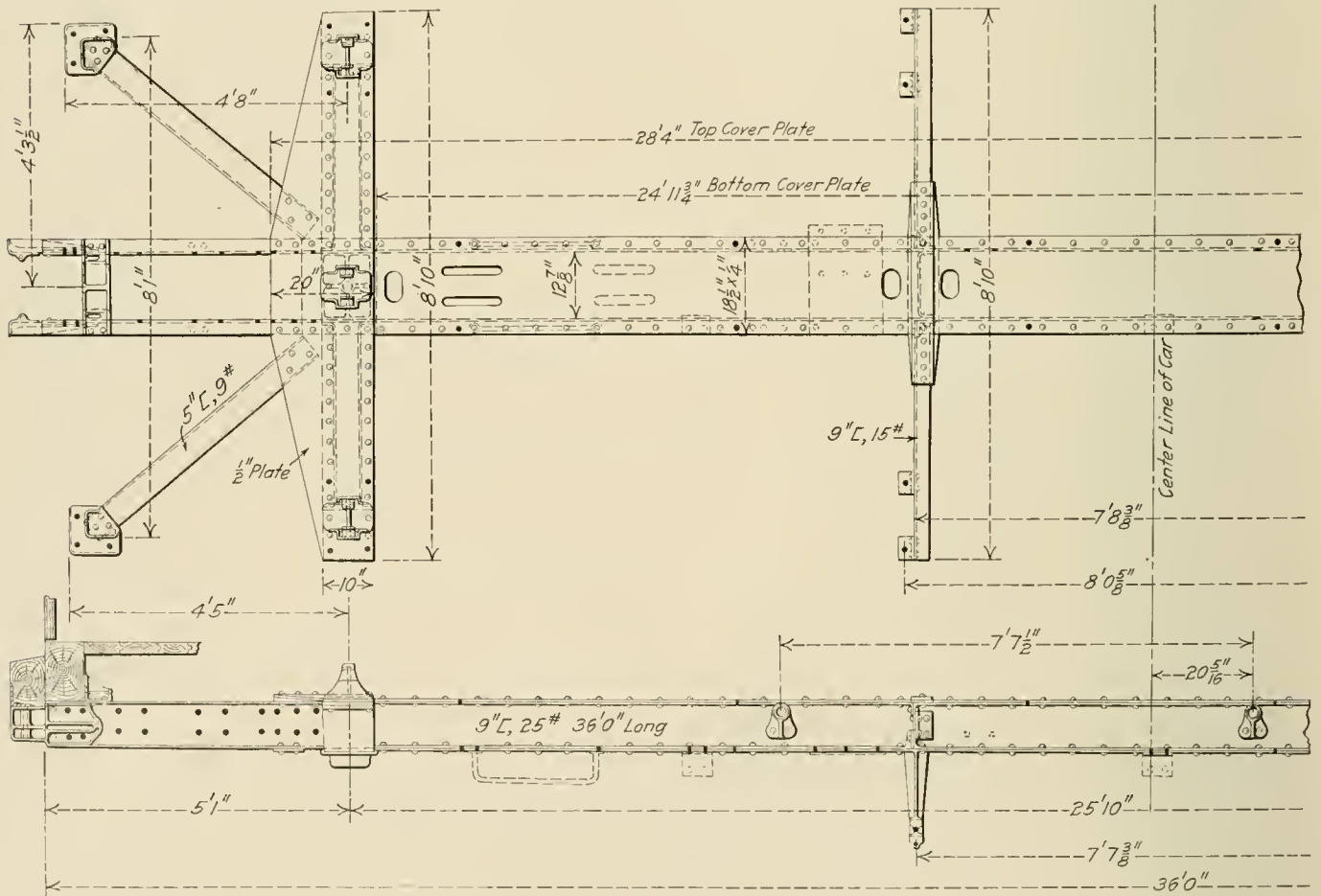

Steel Underframe for Application to Wooden Gondola Cars

sisting of 5 in., 9 lb. channels, 4 ft. 7 13/16 in. long. These connect to the top cover plate of the bolster and to a casting at the junction of the end and side sills of the wooden underframe. As in the case of the box car underframe, the end sill bears against the castings which connect the center sills near the end. On the gondolas the distance between truck centers is 25 ft. 10 in., while on the box cars it is 26 ft. 10 in. The box car

you have saved a 'car day.' Am sure the assistant general manager will take time to look at such notes as I may pass along to him; and the president, too—he is never too busy to hear about a piece of good work in the line of car movement.

"After all, when you come to think of it, that's what we are all here for—to move cars; and if we move the cars the 'days' will take care of themselves."

# LONG ISLAND STEEL BAGGAGE CAR

A 40 Ft. Car of Exceptionally Light Weight,  
Having Arch Bar Trucks With Swing Bolsters

In order to meet the requirements of service conditions existing on its lines the Long Island has recently placed in service 20 steel baggage cars 40 ft. in length and weighing 50,600 lb., built by the American Car & Foundry Company.

Over some of its lines the Long Island handles a heavy bag-

gage and express business during the summer months only, and advantage of this fact has been taken to build a car of exceptionally light weight at a low first cost. During the winter months when these cars are but little used the amount of investment tied up in idle equipment is thus kept to a minimum.

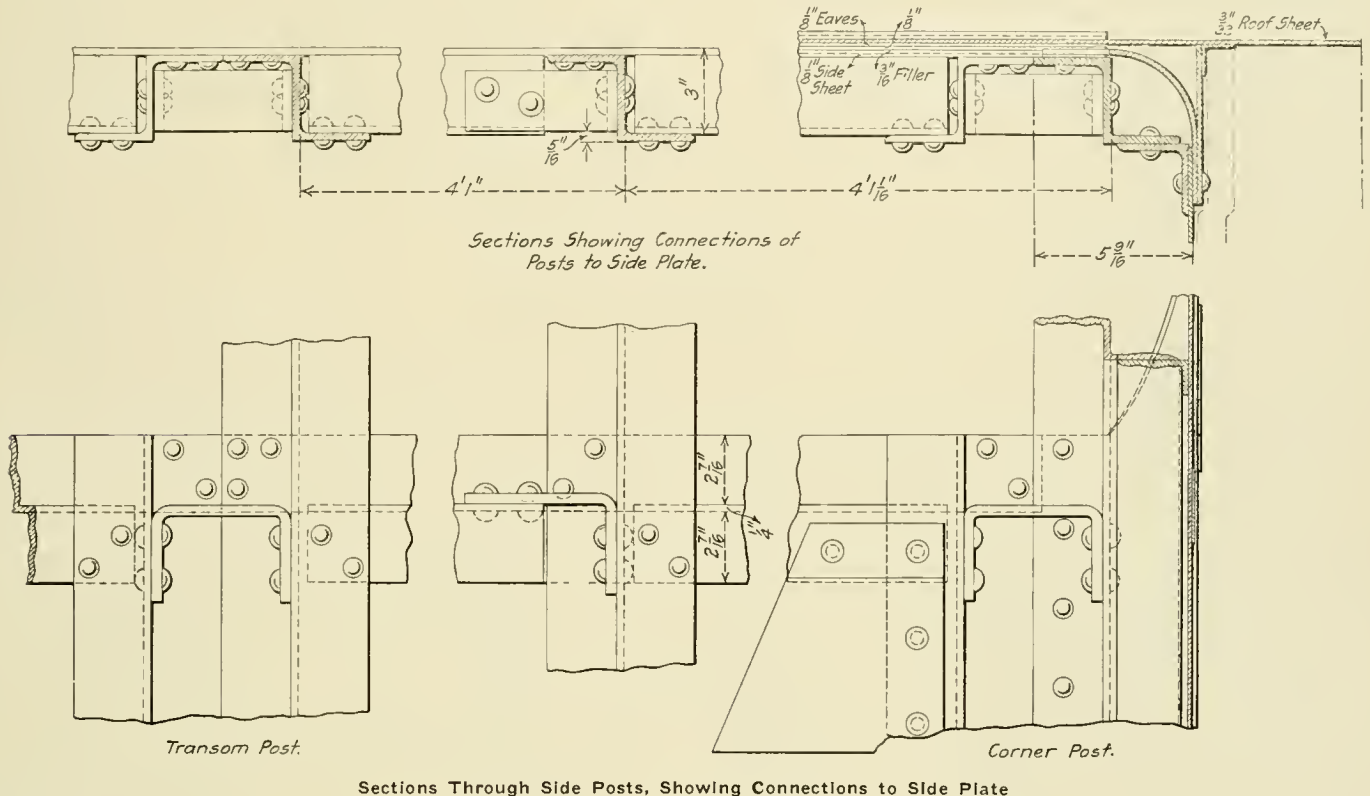

Sections Through Side Posts, Showing Connections to Side Plate

gage and express business, in many cases the consignments to two or three stations completely filling a long baggage car. The consignments for such stations can be loaded into one of the short cars and the car set out, while with long cars it would be necessary to hold the train at the station while the unloading was being done. A large part

## UNDERFRAMES

The center sills are 9 in. channels extending continuously between the end sills. Continuous cover plates both top and bottom are provided, the top plates being  $\frac{1}{4}$  in. thick and the bottom  $\frac{3}{8}$  in. thick. The sills are further reinforced at the holsters by additional  $\frac{3}{8}$  in. bottom plates, each 6 ft. 5 in. long.



A 40-ft. Baggage Car for the Long Island











flanges of the side posts. In order that the top casing may extend inside the car flush with the side post cover,  $\frac{3}{8}$  in. filler blocks are included on either side of the door track.

The floor is made up of two thicknesses of wood flooring, the under side of which is protected by one thickness of No. 22 galvanized iron. The ends of the first course of flooring are supported by angles which are riveted to the inner flanges of the side posts. A wood nailing strip secured to the top cover plate of the center sills on the center line of the car supports the floor at this point. Intermediate nailing strips located about 28 in. on either side of the center line are supported by  $2\frac{1}{2}$  in. by  $2\frac{1}{2}$  in. by  $\frac{3}{16}$  in. angles secured to the diagonal end braces and to the top flanges of the cast steel bolsters.

The roof is covered with  $\frac{3}{32}$  in. steel plate. Longitudinal roof supports of  $2\frac{1}{2}$  in. by  $2\frac{1}{2}$  in. by  $\frac{3}{8}$  in. angle section are placed between the carlines at points about 20 in. on either side of the center line; these serve to stiffen the roof sheets, but the sheets are riveted only to the carlines.

TRUCK

The truck applied to these cars is of a design unusual for passenger equipment. It is of the unequalized arch bar type

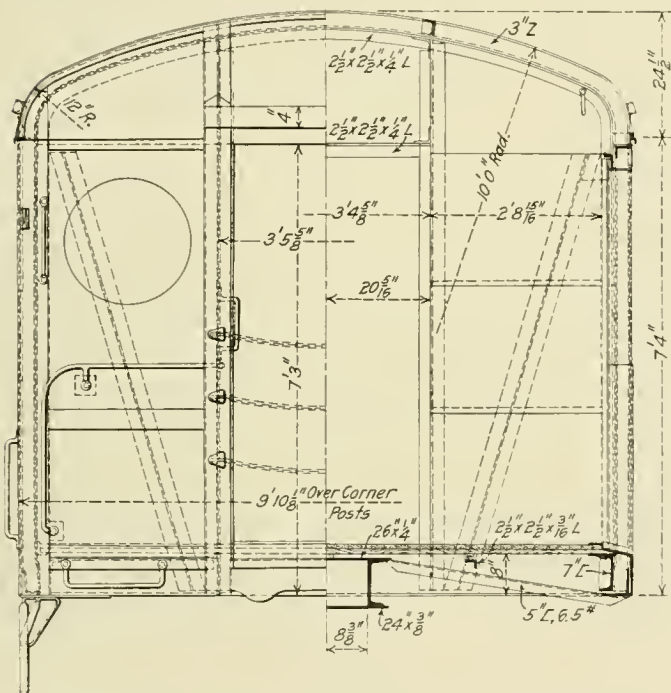

End Elevation and Section Through the Side Door

having a wheel base of 6 ft. 4 in., but has been modified to include a swing bolster. The cross frame is made up of two 12 in., 20 1/2 lb. channels securely riveted to the truck columns. A cast steel spring plank is suspended from the frame by means of swinging hangers, from which the truck bolster is supported on elliptical springs. The wheels are cast iron, 33 in. in diameter and are mounted on standard M. C. B.  $4\frac{1}{4}$  in. by 8 in. axles. Standard  $4\frac{1}{4}$  in. by 8 in. freight car journal boxes are used.

OTHER DETAILS

The cars are equipped with special Sharon couplers designed to be self-centering. The drawbar is of the usual long shank type used in passenger service. A special lug is cast on the coupler body which acts as a stop to the guard arm of the engaging coupler and thus limits the angle between the center lines of the two drawbars.

These cars are the result of a careful study of operating and traffic conditions. Full advantage has been taken of the

requirements of the service to build a car which has a capacity of 50,000 lb. and weighs but little more than 50,000 lb., and one which meets the imposed conditions much better than would a heavier car of more expensive construction.

CAR DEPARTMENT CORRESPONDENCE\*

BY FRANK CLEARY,

Chief Clerk, Car Department, Delaware, Lackawanna & Western, Buffalo, N. Y.

Reviewing car department work in recent years, we become impressed with the constant increase in correspondence and as we study the conditions we are led to believe that with due care and observance of instructions, some of it at least could be noticeably reduced and a more satisfactory condition brought about. The object of this paper is to show some of the conditions that make for unnecessary correspondence and to make a few suggestions that to the mind of the writer would have a tendency to bring about the desired result.

Time expended in correspondence should be used as judiciously and effectively as on any of the other features of car work, and if it is possible to clear the situation with one letter, do not permit oversights or errors to be the cause for writing two. We pride ourselves on our frugality in the use of lubricants and material of all kinds and why not now, of our own initiative, show our ability to cope with the needless correspondence situation?

We are all aware that errors are accountable for much unnecessary correspondence, and which of us is not aware of the annoyance invited by furnishing a wrong transfer or adjustment order, a wrong number or initial in connection with M. C. B. foreign repair bills, or looseness in a report giving an account of a train accident? Allow me to cite an example of the latter.

A trainman makes a report of an accident to his train, involving derailment and damage, and assigns as a reason that a brake beam dropped on one of the cars moving in his train. This report is accepted by his superiors as sufficient information as to the cause. A car department man is instructed to make a report on this accident. He shows the numbers and initials of the cars and parts of each damaged and assigns as the reason for the accident that a brake beam dropped; this report is incomplete and unsatisfactory. He has failed in his mission—has caused delay to the report to the officers and has caused the writing of several unnecessary letters.

In order that his report may be acceptable from a car department standpoint, it must show the cause of the brake beam dropping. This may be a broken brake head, brake hanger, poor track conditions or the absence of cotter keys, allowing the displacement of bolts. It must show also whether the originating or initial defect was entirely new, occurring in movement, or partly old, and whether the defect could or could not have been detected by the inspectors through whose jurisdiction the car passed.

In like manner a trainman reports an accident and assigns a broken wheel as the cause. The car department man, to meet the requirements, goes into detail showing the cause of the wheel breakage, such as a prolonged application of the brake, a worn flange or a seamed tread. He also shows the name of the manufacturer and the date and arranges for proper inspection of the triple and retainer under certain conditions. Should he fail in any particular, he contributes the usual amount of unnecessary letter writing. Reports of this character should be made with the least possible delay and by all means before letters of inquiry from officers are necessary.

This and all correspondence possible should be handled without the necessity of inquiries, and strange to say we are

\*From a paper presented at the meeting of the Niagara Frontier Car Men's Association, Buffalo, N. Y., August 17, 1914.



generally able to make reply to an inquiry on the day we receive it, whereas the original should have received this attention.

It may appear from this that more is expected of the car department man than from the trainman. This is not so. The nature of the work in the department that he is engaged in demands that the special information mentioned be furnished.

A wider field of error and one that furnishes its full quota of unnecessary foreign correspondence and tracing is the work of rendering foreign car repair bills; and we need consider but one feature of this to account for numerous letters and corrections, namely, "Wrong Numbers and Initials."

We will assume that we have several reports of repairs returned to us as it seems that the car record office could not locate any movements of the cars on the line about the dates that reports show repairs to have been made. We ascertain that corrections must be made which generally run about as follows:

We find that the initials reading N. Y. C. & St. L. should read N. C. & St. L.; N. Y. C. & H. R. should read N. Y. C. & St. L.; C. M. & St. P. should read C. M. & P. S.; C. R. I. & P. should read C. R. I. & G.; Can Pac. should read Central Pacific; and numerous others along this same line, occurring through a similarity in the initials, but the wrong recording is by no means justified and with ordinary care could be entirely avoided.

Add to this the wrong number feature, such as 7715 for 7751, and we have the situation complete with the exception of the trouble caused by equipment introduced of recent years bearing numbers of six figures which has a tendency to increase the wrong number taking.

Wrong initials prove the greater source of annoyance, as this means a correction in the amount of the bills made up, which is not occasioned by wrong numbers. Considering the errors in repair bills other than those occasioned by numbers and initials, we find that the Master Car Builders' code of rules, which form the basis of all such charges, have grown so rapidly that they require close scrutiny and precision in making proper charges of owners' defects. This requires ability and experience to recognize the outlines of what constitutes combination of defects denoting rough handling. Still, the foreign repair bills corrected for errors of this nature are comparatively few when compared with the corrections made for wrong numbers and initials, the latter work having remained as simple as it was at the inception of the rules and again evidence is furnished that carelessness is responsible for errors and subsequent loss of labor in making corrections. The great care to be exercised and study required in making foreign repair bills according to the present code and the ever increasing danger of errors, due to the many changes introduced from year to year, leads me to believe that a biennial change of the rules would be desirable, were it not that perhaps more weighty reasons demand the annual change to meet carrying requirements.

It may appear to some that the difficulties outlined have

been overdrawn or that recourse was had to imagination to produce the conditions described. However, I believe on close observation that it is simply a fair representation of what is going on around us on all lines and I am satisfied that it has assumed its present proportions through lack of care on the part of employees taking numbers and initials from the cars and by men in supervisory positions not offering any criticism to the individual responsible at the time the corrections are made. By making corrections without the knowledge of the responsible party and allowing him to continue, the way is paved, not merely for a continuation of this annoyance, but for an increase, making the conditions chaotic.

It is such an easy matter with some little care and attention to perform the work of handling numbers and initials correctly that continual failure on the part of those engaged in doing it would be accounted for by the absence of supervisory attention on the part of men directly in charge of the work.

Of equal importance with the repair bill condition is the work of transfer and adjustment orders and defect cards as established under the Niagara Frontier Association rules and many indeed are the avenues of error in the performance of this work. A receiving line's inspector issues a delivering line's defect card and is informed in due time of tracing that it has been improperly issued and that it should have been issued against some other line. The inspector being questioned, explains it by showing an absence of symbol marks indicating the delivering line, and as symbol marking is part of the system of the Frontier inspection, no member of the association should be required to adopt extraordinary methods to arrive at proper deliveries, but by the co-operation of the delivering line should receive the needed information.

Let us have some consideration for the arbitrator and his office assistants who make the defect cards and transfer orders bona fide by their O. K. stamps, but who have not within reasonable reach, the records of the various lines to test the correctness of car numbers, initials or deliveries and are therefore depending solely on the forces of each individual line to make accurate reports and avoid complications.

The foregoing does not embody all the difficulties we have to contend with in car department correspondence, but represents some of the cardinal features that lead to useless labor and the elimination of them may lead to improvements generally. There is work for all in bringing about the desired result. Let us educate, co-operate with and encourage those about us who may be in need of our assistance to the end that as a department force, not as individuals, our service may become most effectual and satisfactory.

### SPECIAL DINING CAR FOR TROOPS

For the purpose of serving meals in connection with the transportation of troops, the Canadian Pacific has recently put into service commissary kitchen cars, the plan of which was worked out in the sleeping and dining car department. A floor plan of

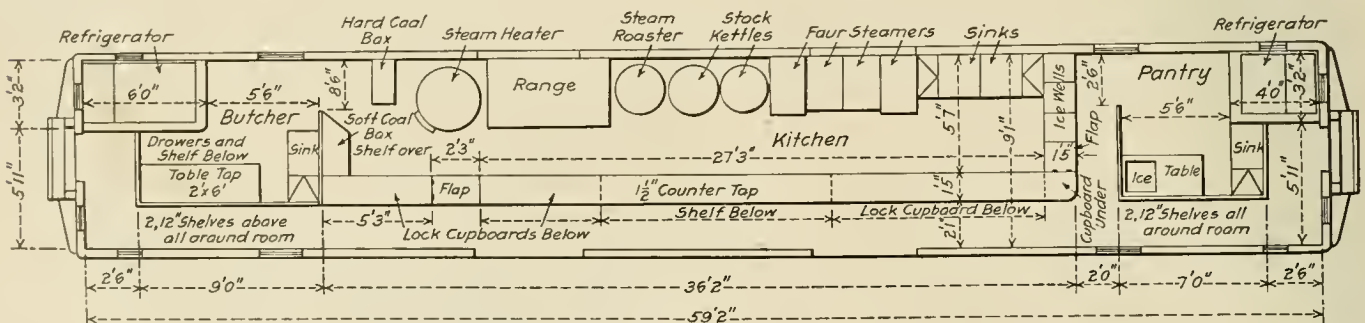

Floor Plan of Dining Car Used on the Canadian Pacific, and Arranged for Serving Meals to Troops while in Transit

the car is shown in the engraving. It will be seen that there is a refrigerator and butcher shop at one end and a combination pantry and pastry room at the opposite end with the kitchen in the middle. The equipment for the latter includes a coal range, a steam roaster, two soup kettles and four steam cookers. The steam utensils are operated by live steam generated in a vertical boiler with which each car is equipped. Each of these cars is capable of feeding 1,000 men three times a day. The floor is covered with heavy galvanized iron sheathing on which are placed heavy baggage racks made in small sections. There are three large water tanks under the car operated by air pressure, in addition to overhead tanks. The total water capacity is 1,490 Imperial gallons. Boxes for holding vegetables are placed under the car and the coal box is so arranged that it extends to the roof and is filled through a trap.

### COACH STEP WITH FOUR TREADS

The four tread coach step shown in the accompanying drawing was developed on the Grand Trunk and is now the standard step for the passenger equipment of that road. The end pieces and risers are of  $\frac{1}{8}$  in. steel while the steps are of wood  $1\frac{1}{2}$  in. thick covered with  $\frac{5}{16}$  in. knob rubber treads. The steps are supported at the ends on  $1\frac{1}{2}$  in. by  $1\frac{1}{2}$  in. angles riveted to the end pieces, and all except the bottom step are further supported by the pressed steel risers. The steps are secured to the angle supports by  $\frac{1}{4}$  in. carriage bolts, the heads of which are recessed and covered by the rubber treads, while 1 in. No. 10 screws are used to secure the steps to the risers. Each step has a rise of  $9\frac{1}{4}$  in. and a clear tread  $7\frac{9}{16}$  in. wide, with the bottom step normally  $14\frac{5}{8}$  in. above the top of the rail.

The standard step formerly used on the Grand Trunk was the same that is used on sleeping cars. This step had but three treads be-

### STEEL CONSTRUCTION IN FOREIGN CARS

The use of steel in rolling stock in Great Britain and some of the British possessions, while not carried to the extent that is becoming general in America, has some interesting applications. One of the noticeable features is the use of truss rods on side sills, a form of structure which has comparatively little application in America.

Among the illustrations are included several views of a car

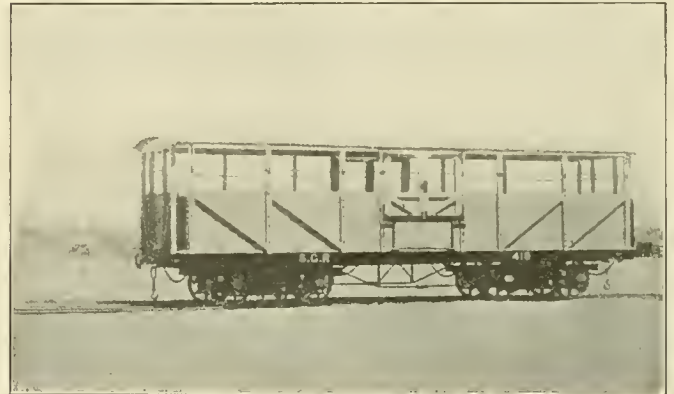

Sudan Government Railway Cattle Car

which is one of a number recently built for the Metropolitan District Railway, London. The body framing of this car resembles in some respects the cars in use in the New York subway. The underframe is the feature of particular interest, and it will be noted that there are but four sills employed and that the center sills or longitudinals are spaced considerably farther apart than is the general practice in America. The truss rods

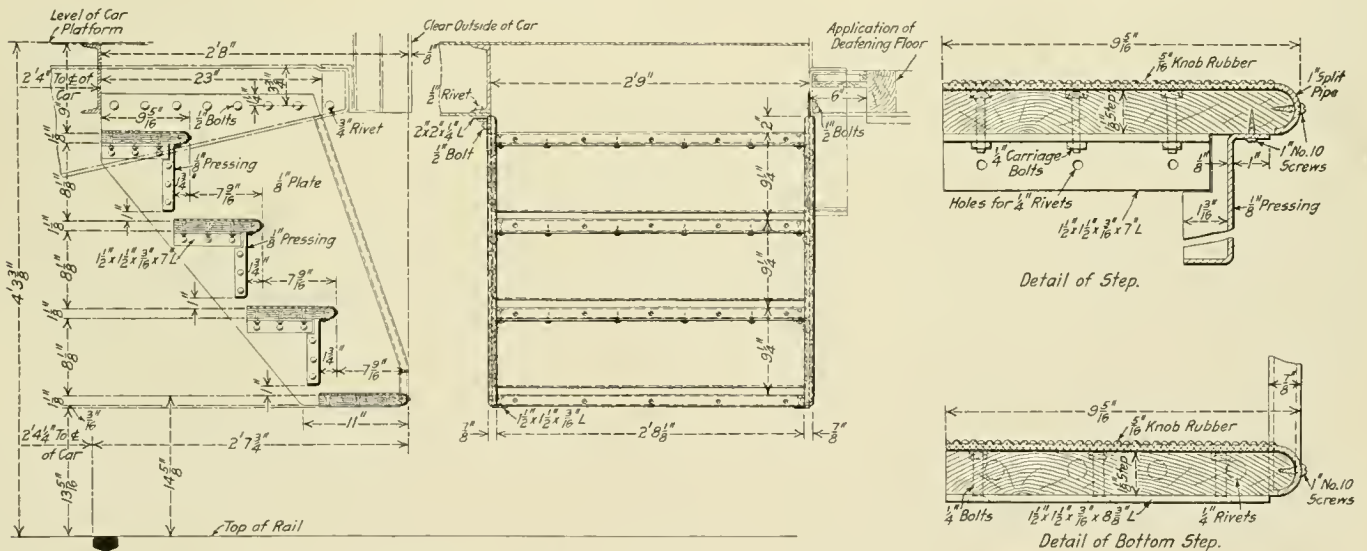

Standard Four-tread Coach Step Used on the Grand Trunk

low the platform and stepping boxes were required for the use of passengers entering or leaving the coaches. The stepping box, however, was found to be dangerous on account of its small size and the distance passengers had to step to reach the top of the box. Passengers would often step on the edge of the box and turn it over, which very frequently resulted in severe injury. Since the adoption of the four tread step passengers are able very comfortably to enter or leave the coaches without the use of stepping boxes from platforms placed at track level.

USE OF LATHES.—The lathe today on much work should be a roughing tool and the grinder a refining tool.—*American Machinist.*

used in connection with the side sills or solebars are a noticeable feature, and it will be noted that the cross ties or crossbearers are so formed as to pass under the center sills while the body bolster is placed below all the sills. The interior panels of these cars are of steel in mahogany frames, with steel ornamental holdings at the cornices. The cars are 49 ft. long over the end sills and 8 ft. 8 in. wide over the framing while the trucks are spaced 34 ft. 1 in. between centers. They have a seating capacity of 48; the trailer cars weigh about 50,000 lb., and the motor cars about 76,000 lb.

The use of the truss rod in connection with the channel section side sill is again shown in the military cars of the Great Indian Peninsula Railway. The center sills of this car are







also of channel section and the car is 68 ft. long over end sills, with the trucks placed at 47 ft. centers. Some sleeping cars built by the London & North Western for the West Coast Joint Stock form still another example of the truss rod method of

few years for the Sudan Government Railway the side sills consist of 10 in. I-beams. At a distance of 2 ft. 10 in. from the end sill the side sills are bent toward the center of the car, making the end sill 7 ft. long, while at other points on the 60

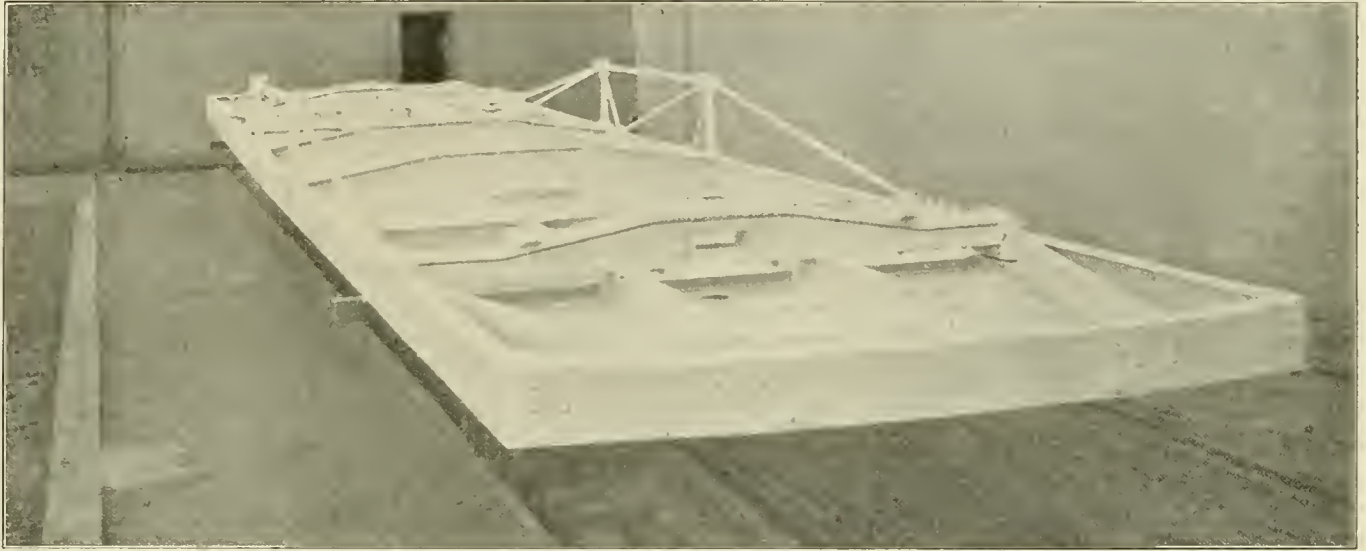

Underframe of the Metropolitan District Car

construction. These cars are mounted on six-wheel trucks, and while not in use on these particular truck frames, it is of interest to note that the truss rod arrangement is employed for strengthening the side frames of steel trucks in some cases on

ft. frame the width is 8 ft. 10 in. The center sills are 6 in. channels, and both the center and side sills are fitted with 1 1/2 in. truss rods with queen posts spaced 14 ft. 5 1/8 in. apart. There are three central cross members composed of 6 5/16 in.



Steel Motor Car for the Metropolitan District Railway

English railways. The West Coast sleeping cars are 72 ft. long over the buffers and 68 ft. long over the end sills with the trucks placed at 45 ft. centers.

In a number of sleeping and buffet cars built within the past

channels extending in one piece across the frame and passing under the center sills at points 15 ft. 6 in. from each end, while another cross member of the same section is cut by the center sill. The body bolsters are 10 in. channels and extend in one



piece across the frame, which is counterbraced with 3 in. by 3/8 in. flat iron.

Steel construction was also used in some of the older Sudan Government cars, in which the side sills were of channel section 7 7/8 in. deep and the center sills of the same cross section. The frame is 45 ft. over the end sills and again the truss rod construction is employed, the side sills being trussed by tie rods 1 1/4 in. in diameter, the lower ends of the queen posts being braced by 2 in. by 1 in. by 3/8 in. angles to the center sills. In this underframe the cross members are 7 7/8 in. channels and are cut by the center sills.

In freight service the Sudan Government railway has a number of 30-ton open steel cars of double bogey or two truck type and also 30-ton covered cars in both of which the side sills,

## FORM FOR NOTING FREIGHT CAR REPAIRS

BY WILLIAM J. KELLY

Little system seems to be followed in methods of recording results of the inspection of freight cars on the repair track. When inspecting a string of bad order cars one or two men are usually assigned to the work, sometimes one on each side of the track. On some roads the method employed by the inspectors to call the attention of the repair men to the defects is to note them on the side of the car with chalk. On others the defects are noted on any piece of paper which happens to be handy, afterwards being copied

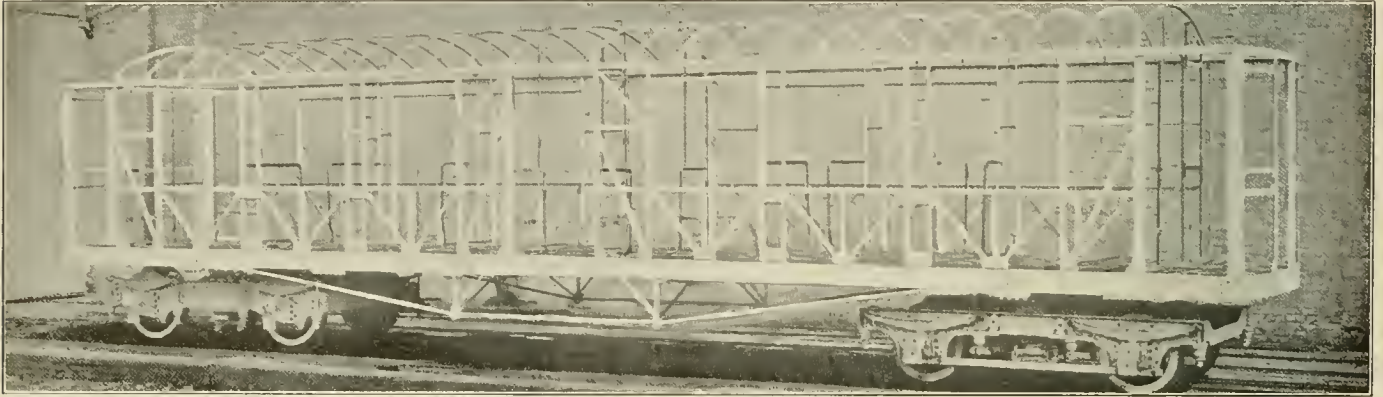

Steel Framing for the Metropolitan District Car

center sills and cross members are 9 in., 21 lb. channels, the four central cross members being cut by the center sills, while the main cross members or body bolsters extend in one piece across the frame. The trucks of these cars have pressed steel frames with a wheel base of 5 ft. 6 in., and are placed at 22 ft. 11 in. centers. The 10-ton covered two truck cars for freight service have their side sills, center sills and cross members all of 7 7/8 in. channel section, the underframe being trussed by 1 1/4 in. tie rods with queen posts 6 ft. 1/2 in. apart. The 10 ton open cars of this type weigh 22,400 lb. In the 30 ton two truck cattle cars, which have a weight of 32,500 lb., the side sills, center sills and cross members are all 9 in. 21 lb. channels with 1 3/4 in. truss rods on the side sills. In the 15 ton covered and open single truck steel cars the underframe members are all 9 in. channels, while the sides, floors and ends are of 3/16 in. section.

STEAM CARRIAGES.—Some of the members of the committee of the House of Commons now sitting, on steam carriages, having expressed a wish to be enabled to judge for themselves as to the practicability of a power so long suspended by legislative prohibition, in the shape of tolls, were invited a day or two since by Col. Sir Charles Dance, who is just returned from the continent, to accompany him in his steam-carriage on a trip to his house at Hartford, near Stanmore. The invitation being accepted, the carriage started with a party from Oxford street, at half-past nine in the morning. At Hartford a dejeuner was provided by the care of Sir Charles; after partaking of which, and witnessing some experiments in drawing heavy weights by a steam-carriage (with a view to military purposes), the party set off on their return to Oxford street, which they reached at half-past twelve, having accomplished the distance in forty-five minutes. On the journey out the carriage went up Stanmore hill at the rate of eight miles an hour, although this is an ascent where the mail and stage coaches generally make use of six horses. Besides Lord Darlington and other members of the committee, the Master General of the Ordnance and several other distinguished persons were of the party.—From *American Railroad Journal*, August 15, 1835.

into a book provided for that purpose. This method requires extra work in making the permanent record and does not leave a record on the car for the repair men.

The writer believes that for this purpose the form shown in the engraving possesses a number of advantages. It should be printed on cards stiff enough to stand tacking on the side of a car. The defects are noted on the card by one of

A. B. C. R. R.				
O	END	CAR NO. <i>84324</i>	CO. <i>70. N. H. &amp; H.</i>	STATION <i>Harrison, Iowa</i>
		INSPECTED BY <i>Joseph M. Gardo</i>	<i>John A. Stett</i>	DATE <i>7/25/14</i>
	REPAIRS NEEDED	REPAIRS MADE	MATERIAL REMOVED	REPAIRED BY
B	<i>Coupler 57 Head 9 1/2 Bolt</i>	<i>One (1) New Pitt Coupler</i>	<i>One (1) Major Coupler 5 1/2 Shank 6 1/2 Bolt Broken at H</i>	<i>J. P. Conway 26</i>
B	<i>Brake Beam</i>	<i>One (1) New "Coco"</i>	<i>One (1) Wagon Brake Beam 2 Compression Member Broken</i>	<i>L. Payne 17</i>
A	<i>Brake Hanger Clavis Bolt</i>	<i>Two (2) 6L Bolts Bolt 3 1/4</i>		<i>J. Burns 12</i>
O	<i>Wheels 529 Cut Journal Journal Bearings 529</i>	<i>One (1) New Pair 529 Two (2) New Journal Bearings 529</i>	<i>One (1) Pair 529 wheels Cut Journal Two (2) Journal Bearings</i>	<i>C. Fisher 29 A. McKean 6 M. Moran 5 D. Holland 33</i>

Form for Recording Freight Car Repairs

the inspectors or by a clerk accompanying the inspectors. The card is then tacked on the side of the car where it serves as a guide for the repair men. As each man finishes a job he notes the repairs made and the material removed and signs the card. This gives a clear record of the progress of the work at any time and shows just who is responsible for each job. When the repairs have been completed the cards may be removed from the car and filed.

# SHOP PRACTICE

## MASTER PAINTERS' CONVENTION

The forty-fifth annual convention of the Master Car and Locomotive Painters' Association was held in Nashville, Tenn., September 8 to 11, inclusive, Oscar P. Wilkins, master painter of the Norfolk & Western, presiding. The convention was opened with prayer by Mr. Spain, secretary of the Nashville Y. M. C. A., and the association was welcomed to the city by W. S. Mitchell, chief of factory and shop inspection of the state of Tennessee. Mattison Wells, private secretary to the mayor of Nashville, also welcomed the association to the city.

### PRESIDENT'S ADDRESS

President Wilkins spoke of the value of these annual conventions, and called upon the members to co-operate in the exchange of ideas, as without this the association could not hope for success. The master painter should be progressive, seeking to increase the efficiency of his department. Attention was also called to the necessity of developing young men in the painting trade who will be called upon later to take charge of departments.

### TEST COMMITTEE REPORT

From inquiry it has been found that new roofs have to be applied to steel cabs about every ten years, and in every instance the old roof was worn out at the point where the rain guard was applied. This catches the coal dust, soot and cinders from the stack, which with water forms an acid which very easily eats through the paint and destroys the roof. This condition is in a lesser degree also found to exist wherever an angle iron or molding was attached to the body of the cab. The steel underframes of tenders and cars are also exposed to deterioration and destruction from acids to a greater degree even than the steel cabs. It is, therefore, necessary to carefully watch these structures and keep them well painted so far as possible with a paint that will resist this acid action. The committee recommended a mixture of red lead and ferric oxide, or any of the many pigments that have a tendency to minimize the oxidizing influence of red lead for a primer for steel frames, roofs, etc., this mixture to be mixed with linseed oil. This primer should be protected with a second coat of paint that will give the greatest possible resistance to the action of acid and moisture, to which this class of equipment is exposed. The committee then exhibited some test panels of different kinds of paint that had been placed under tenders in various parts of the country. From these tests it was determined that the plates on which were applied and baked the standard class of paints and varnishes are in better condition at every point where exposure was made. It was also conclusively proved that the baking process retains a luster of the varnish and is more free from checks than the air dried plates; that baking is not detrimental to the appearance of the equipment, and as it presents a firmer surface to the elements it is reasonable to presume that it would be more economical to maintain in a sanitary condition. It was also shown that one coat of enamel is better than two coats of flat color in both appearance and durability.

The report is signed by J. W. Gibbons, chairman, H. Hengeveld and A. S. Baldwin.

### PAINTING STEEL CARS

A. J. Allen (D. L. & W.): The most essential part of the painting begins with the man who inspects the cars while they are being built, for a job well started does away with two-thirds of the trouble. The greatest of care should be exercised in seeing that every concealed part is well painted

with some good elastic paint and especially all joints should be red-leaded, for I do not think that anything has as yet been discovered to take the place of red lead. In putting on the insulation on the inside of the sheathing a cement or paste is used to help stick it before putting on the strips, etc. This cement or paste in one case had eaten the life out of the paint. It probably contained an acid of some kind, presumably carbolic, which had left the paint just as so much dust. Where the cement had not been applied, the paint was in splendid condition.

The roof and deck are very important. If it is thoroughly cleaned before painting and well painted, it will save endless trouble. Where it is possible, every sheet that goes on a roof should be sand blasted, and primed with red lead immediately afterward. We have experimented with various primers, but finally came back to red lead for roofs. We sand parts of the roof most exposed to flying cinders. The system of roof painting we are following at present, and which has been very satisfactory is red lead, followed by two coats of an elastic paint. Roofs are also given a coat between shoppings at the terminal wherever possible. They must be kept well painted.

We have experienced no trouble in painting or taking care of the body of a car. This, if done according to a system, and the proper amount of care taken in applying the different coats, should not cause any more trouble than a wooden coach, provided, of course, that the surface is right to start with. This is very important; every inch should be thoroughly clean and free from rust, grease or scale. In fact, so long as one is using a good reliable paint, the responsibility for the wear rests mainly with the one applying the material.

The following is the method we follow in painting the body: Prime with steel car primer, allowing to stand 72 hours, and if not thoroughly dry let it stand longer; coat again with steel car surfacer and allow 48 hours if possible. If this cannot be done, 24 hours will be sufficient. Follow with three or four coats of surfacer, as the case may require, allowing 24 hours between coats for drying. Guide coat and after 24 hours, rub and allow to stand until thoroughly dry. Apply color. Allow 24 hours and color again. On the following day, ornament. After 24 hours, varnish with one-fourth rubbing varnish and three-fourths finishing varnish. Allow 48 hours to dry, after which apply a coat of clear finishing varnish. Allow 72 hours, then finish. This will take about 23 days. Of course, the time can be shortened considerably, but if it is, the life of the job will be shortened correspondingly.

J. B. Wright (B. & O.): While it has been found that the baking oven has given very good results in painting steel equipment, it is believed that it will not be universally used on account of the expense of painting the equipment in this manner, especially in establishing the plant. This process also eliminates the opportunity for doing other work on the cars while they are being painted. While this is very advantageous from the painters' standpoint, it will require holding a car for a longer time. The surfacers used in painting steel equipment are of great importance. They must be inhibitive and elastic. In order to decrease the number of necessary coats applied a smoother metal surface must be provided by the metal workers. The decks, deck screens and roofs of the steel passenger equipment cars are causing the greatest trouble. These parts should be well painted when the cars are built and carefully watched while in service, re-painting as often as necessary for their protection. Our



road has adopted the practice of sprinkling sand in the last coat of paint on the roof in order to eliminate the trouble caused by hot cinders which fall thereon, burning and destroying the paint coating. It is believed that the use of plain colors for finishing the interior of steel cars will be found very much more practical and economical, as with the grained finish it is difficult to repaint parts which frequently become scratched or chipped.

#### DISCUSSION

John Gearhart (Penn. R. R.): We had the same experience with the cement of the insulation eating off the paint underneath it, and now we apply the insulation using our regular freight car paint mixed very heavy, about 14 lb. to the gallon, for the cement.

H. M. Butts (N. Y. C. & H. R.): We have considerable trouble in keeping the paint on our steel roofs. The same paint applied to tin or wooden roofs shows excellent wear, but when applied to a steel roof it does not wear well at all. The roofs have to be renewed twice a year in order to maintain them at all. It might be that a different metal used for the roofs would give much better service. Since sand-blasting our roofs we have been getting better results. They are now being painted with three coats of Pullman body color paint mixed with pure linseed oil, with no Japan or dryer.

M. L. Shaffer (Penn. R. R.): All roofs are sand-blasted and covered with a coat of primer and two coats of our standard freight car color. I believe if we can get other vehicles for our pigments in the roof paint that we will get better results. In order to get the best results we must carefully maintain the roofs at terminals.

J. H. Pitard (M. & O.): I think we should use thicker coats of paint on the roofs to offset the effects of the rain and sun, and cinders.

W. O. Quest (P. & L. E.): It does not make any difference how much you sand-blast your car if you use a poor paint. Something that has not life enough in it to last six months, it seems to me, is pretty poor. We need oil, for oil is the life of paint; at the same time we should not use dryers, and the further away we get from the hard oxidizing matter on the steel roofs the better the results will be.

H. J. Bruning (L. & N.): The following formula which we use for sand-blasted paint without any trouble may also be applied to the roof. We take 5 lb. of dry Printz metallic paint, then 1 lb. of red lead and color that down with lamp black, then put in a half rubbing varnish and half finishing varnish, and add enough turpentine so that it will work well.

#### INTERIOR FINISH OF PASSENGER CARS

A. R. Given (Can. Pac.): The following method is used for finishing suburban and first-class cars:

These cars are mahogany and a standard mahogany filler is used. It is allowed to dry in well before wiping off. The following day the car is varnished, using rubbing varnish and 48 hours is allowed for this to dry. Japan putty, colored to match the work, is used for filling in. The whole of the work is then sandpapered and well dusted down. Two coats of rubbing varnish are then applied to the suburban cars and three coats to the first-class cars, to be well sandpapered between coats. Each application of varnish must stand at least 48 hours before applying the next coat. The suburban cars are left in the gloss.

On first-class cars, after being allowed to dry for several days, the work is then rubbed down, using No. F pumice stone, raw linseed oil and a small quantity of benzine. The sashes are oiled, filled and given three coats of rubbing varnish. The seat arms are oiled and given three coats of rubbing varnish. The foot rests and seat rails are dipped in an acid brown water stain. When dry, they are again dipped in a mixture of 4 parts boiled linseed oil, 1 part turpentine, and, when dry, given three coats of rubbing varnish. The castings and heater pipes

are painted with two coats cherry color. The sash beads are dipped in oil and varnished two coats before glazing. All doors, rods and other movable parts are treated in the same manner as the body of the car. The floor of the car is primed, well puttied and given two coats of standard floor color. All trimmings are oxidized.

The following method is used for finishing sleeping and dining cars:

The cars having been carefully sandpapered and cleaned down are afterwards filled, using standard mahogany filler, allowing it to dry in well before wiping off. The following day the car is varnished, using rubbing varnish and 48 hours is allowed for this to dry. Japan putty, colored to match the work, is used as before. The whole of the work is then sandpapered, and well dusted down. Three coats of rubbing varnish are then applied and allowed to dry 48 hours between coats, and well sandpapered between coats. After being allowed to dry for several days the work is then rubbed down using No. F pumice stone and raw linseed oil with a small quantity of benzine. Berths, curtain boxes, rods, doors, chairs, etc., are brought up in the same manner as the body of car. Berths are primed, puttied and given two coats of cherry color inside. Backs of seats are oil stained to match the car and receive three coats of rubbing varnish. Headboards are stained and receive three coats of rubbing varnish. Side tables are filled, receive three coats of rubbing varnish and are left in the gloss. The sashes are oiled, filled, receive three coats of rubbing varnish and are rubbed. All cupboard fronts, doors, shelves, etc., are filled. The inside of cupboards is oil mahogany stained, receives three coats of rubbing varnish and is left in the gloss. All kitchen woodwork is oil stained to match the pantry, receives three coats of rubbing varnish and is left in the gloss.

The water tanks are given several coats of aluminum bronze. The pipes are given two coats of cherry color. The heater pipes are painted dark green. The floor of the car is primed, well puttied and given two coats of standard floor color (dark green). Some of these cars have cork floors, which are given one coat of boiled linseed oil and waxed.

The headlinings of colonist, tourist, suburban and first-class cars are of the agasote style. The operation is to prime the back before the carpenters nail it in position; after being nailed up, it is primed. All nail holes and joints are well puttied and sandpapered and two coats of standard color (pale green) are applied, being well stippled between coats. Stencil decorations are put on and shaded. The whole receives three coats of light varnish.

Headlinings of sleepers, diners, observation and parlor cars are of the canvas type and are given a good coat of paint on the back before being put up. After being put up they are treated in the following manner: Before applying the duck canvas to the veneer, all screw holes, joints and other defects are primed and puttied up smoothly, using Japan putty for this operation and allowed to dry thoroughly. When sandpapered down, the whole of the veneer is now given a good coat of strong glue size. It is then ready to receive the canvas. The canvas having been previously cut to the required shape is given a coat of paste which is a mixture of glue and flour. After sizing the canvas it is allowed to stand for a short time before applying. It is then ready to put on, care being taken to rub it well down so as to remove all creases and to give an even surface, also allowing the joints to lap a little to prevent opening up. This operation should stand at least 24 hours to thoroughly dry out. The canvas is then given a good coat of glue size. Two coats of surfacer are applied, being well sandpapered between coats. All joints and other defects are glazed. After the glazing is dry, it is given a good sandpapering until an even surface is obtained.

The canvas is now painted two coats, using a tint suitable for the gilding ground of aluminum leaf. The whole of the ceiling is sized and colored a little to guide the operation. Alu-

minum leaf is now applied, care being taken to see that no parts are missed. A thin coat of white shellac is put on to prevent the edges from curling. A lacquer is then made up and applied, consisting of gamboge and asphaltum, and the whole stippled.

S. E. Breese (L. S. & M. S.): Almost the entire passenger equipment of the Lake Shore & Michigan Southern Railway is finished in mahogany color. On receiving a new car from the body shop, the surface is carefully sanded to remove any particles of dirt, finger marks, glue, etc. After the surface is dusted down, we apply a coat of oil stain, which corresponds to our standard shade. This stain we make from one part Bismarck brown, one part rose lake and 16 parts burnt sienna. This is followed with one coat of paste filler tinted to the same standard shade. After sanding to insure an even surface, one coat of rubbing varnish is applied, over which all nail holes or any uneven places in the wood are carefully puttied. The whole is then sanded with 00 sandpaper and a second coat of rubbing varnish applied. The surface is again sandpapered and a third coat of rubbing varnish applied, which also is sanded, and a fourth coat applied.

We allow as much time as possible for this coat to harden, all of which depends upon the shop's schedule time. Our average shop time for finishing a coach is about nineteen days. After the varnish is in condition to rub, we do so with water and pulverized pumice stone; after washing the surface carefully with water and then drying, we again rub the surface with a specially prepared oil polish and rotten stone, and wipe dry. This concludes the finishing of the wood.

The headlinings are finished as follows:

The same primer is used as on the body outside, and is followed by one coat of surfacer, putty for holes, and two coats of rough stuff. This is rubbed with lump pumice stone and water to a surface, following which three coats of flat color are applied. Over this we put our decorations, followed by three coats of rubbing varnish. We rub the varnish with pulverized pumice stone and water, then oil and wipe dry. We do not polish this surface.

We give the saloon three coats of flat white followed by two coats of white enamel. In the first coat of white, we use on an average a pint of oil to a gallon of the white, for a priming coat. The trimming work is carried through in the same manner as described above. The floors are first primed with the same primer used on the body of the car outside, and allowed to dry for several days before the subsequent coats are applied.

J. McCarthy (G. T.): All natural wool filler consists of corn starch made with pure linseed oil to a semi-paste form with a quantity of sienna and other staining colors added to give the wood finish the required shade. The filler is thinned down with benzine to a working consistency and when applied and sufficiently evaporated it is wiped across the grain of the wood, wiping the surface dry and leaving the open grain well filled. The staining colors ground in japan for coloring the filling and putty, and for staining, are generally superior in quality and not so liable to fade as the colors ground in oil. A good grade of white shellac is always used.

#### RUST INHIBITIVE PAINT

J. H. Pitard (M. & O.): All paints are rust inhibiting only in proportion to their adaptation to metal protection, and the term of their protective qualities is not indefinite; it is rather in proportion to the care that is taken to renew them when such paints reach the end of their natural life and before rusting has begun to appear. In the writer's experience, the best results have been obtained by the use of red lead and linseed oil for first or under coats, followed by one or more coats of carbon black. In the discussion of this subject regarding the fitness of paints for metal protection, the question of preparation of the surface is an important determining factor and should receive due consideration where the maximum durability is desired or expected. The nearest approach to a rust inhibitive paint is the

result of combining chemicals and conditions of application in such a way as to make them mutually supporting.

#### CLASSIFICATION OF REPAIRS

J. F. Gearhart (Penn. R. R.): We classify the exterior repairs on our cars separately from the interior, the exterior being designated by numbers and the interior by letters. We have our piece work prices for each operation for any of the different classes in detail, and with the exception of the amount of scraping or new work to be done on a car, we are able to tell at a glance what a car will cost. We have our organization divided into service men, liners, who do the varnishing, and inside men. We know how much the panels are worth, and by carefully going over the car we can tell in a few minutes exactly what the car will cost to be repainted. We are not asked to give an estimate on any car, unless it is something special.

Mr. Hengeveld moved that it was the sense of the meeting that cars should be classified separately inside and out, which was seconded and carried.

#### PAINT SHOP APPRENTICE SYSTEM

B. E. Miller (D., L. & W.): The apprentice system on the Lackawanna Railroad is organized on lines corresponding closely to those followed on many of our larger railroad companies. Schools of instruction in charge of a supervisor of apprentices are maintained at three of our principal shops, namely, Kingsland, Scranton and Buffalo. These have been in operation during the past four years and attendance is compulsory, which naturally includes paint shop apprentices. Apprentices are entered between the ages of sixteen and eighteen. The average age upon entering is sixteen and one-half years.

A four-year course is prescribed for all the trades and a total service of 10,000 hours is required before a diploma is granted. The pay is raised every 2,500 hours from 8½ cents an hour for the first period to 11½, 15 and 18 cents an hour for the following three periods. Upon the recommendation of the shop and school instructors of apprentices and the general foreman, with the approval of other officials, a diploma may be granted after serving three years of 2,500 hours each if the apprentice believes himself capable of earning a mechanic's wages.

No hard and fast rule is followed as to assignment and periods of service in the various classes of work into which the four-year term is divided. Much depends upon the boy himself and his aptitude to master the tasks put before him. With some variations, largely unavoidable, the following schedule is adhered to at Kingsland, our principal shops, where both passenger car and locomotive work is handled: general locomotive work, varnish room work, general work on floor, body work and surfacing, interior finishing, general work and glass plating, and striping and lettering, the changes being made every six months. During the last six months the work is governed by the conditions of the shop.

During the fourth year of their apprenticeship, we permit working on a piecework basis, the earnings being prorated if employed with other workmen. The privilege, however—entirely at the option of the company—is extended only to boys sufficiently advanced and entitled to it because of meritorious conduct.

It is to be regretted that from an educational standpoint, the average applicant for a position as an apprentice on railroads generally is apt to be somewhat lacking. It is particularly difficult to secure good material for paint shop apprentices, the advantages offered in the machinist and other trades having a tendency to draw towards themselves the most desirable of the applicants.

The apprentice schools on the Lackawanna railroad are in charge of a supervisor of apprentices and an assistant, and are maintained entirely at the expense of the company. Every apprentice is compelled to attend three hours each week. A set of drawing instruments is provided for all pupils, which, however, they are expected to pay for on the instalment plan, small sums to apply being withheld from their pay, periodically. In-



structions are given in mechanical drawing, free-hand drawing, arithmetic and writing.

For the benefit of paint shop apprentices, an additional list of studies has lately been added, of particular interest to them. The subjects taken from text books and other sources of information are as follows: brushes, car coach and carriage painting, color, color harmony, color mixing, oils and japans, staining, varnishing, enameling, flattening and gilding. It is expected that the study of these subjects will prove of great interest to the boys and that they will impart to them much essential knowledge otherwise obtained in a haphazard way, if indeed in some cases it is acquired at all.

Of the men that have taken the paint shop course 25.35 per cent of all apprentices employed during 14 years are still in service. The greatest number leave during the first year of service, the percentage being 45.09. The percentage leaving the second year is 8.45, and for the third and fourth years the percentage is only 2.82 and 2.81, respectively.

Martin L. Shaffer (P. R. R.): In a piece work shop there should be established, where practical, an apprentice gang, to be composed entirely of apprentices; for example, an apprentice serving his first year, one in his second, one in his third and one in his fourth year; as an apprentice serves out his time a new apprentice to be employed so as to keep the gang on a working basis as explained above. These apprentices should be under the supervision of a practical painter, that they be given their work and permitted to start and finish it; all work to be performed on a day work basis with an increase of wages approximately two cents (\$.02) every six months, this to be based on their employed rate.

#### DISCUSSION

J. W. Gibbons (A. T. & S. F.): If we could get our apprentice schools to take up part of the time teaching the painter apprentices elementary lessons in chemistry as pertaining to paints and oils, it would be of great advantage to the future generation of painters and to those who may employ them.

#### REMOVING PAINT BY SAND-BLASTING

W. O. Quest (P. & L. E.): We are firm in the belief that the sand-blasting method of cleaning metal or stone surfaces is the best, the most effective and the most economical to use. This preparatory cleaning must be figured upon regardless of cost in order to avoid making the costly mistake of painting over live corrosion or mill flash scale. If a sand-blast system is properly installed and handled its work can be depended on for a maximum of service results. The average cost of removing paint, etc., from an 8,500 gallon tender tank by the sand blast is a fraction less than eight mills per surface foot, and the total piece work price is \$3.33. The same tank cleaned with the best known non-dry-hardening caustic mixture, soluble in water, will cost \$7.10, and even then the flash scale will not be wholly removed. The cost of chemically removing the flash scale, and of neutralizing the acid used is prohibitive. This leaves the sand-blast as the only practical metal cleaning method that will provide a clean, inert surface to receive paint. A coarse clean sand should be used. The sand-blast may also be used to good advantage in cleaning the metal prior to welding by electricity.

At the McKees Rocks shops all large sand-blast work is done in an elevated track sand storage house. The sand used for blasting is used again for sanding locomotives. This also eliminates the trouble from dust in other shops. The sand-blast can also successfully be used for glass ornamentation work, and is, in fact, superior to the acid method of cutting. There are, nevertheless, cases where the chemical removers can be used to much better advantage than the sand-blast, especially on small castings, driving wheels, dome and sandbox base castings.

F. A. Weis (C. R. R. of N. J.): The sand-blast not only removes the paint, but also the rust and flash scale, and at the same time roughens the metal just enough to allow the paint

which is applied to adhere firmly, better than it could to the original planished surface, and this firm adhesion not only protects the metal surface better, but insures longer life to the paint. Moreover, the operation of sand-blasting, when it is properly done with dry sand, produces a clean surface that is absolutely free from moisture or possible traces of chemicals or wax that might cause corrosion of the metal or prevent a firm adhesion of the paint to the surface.

The sand-blasting operation consumes about as much time as is required to apply the remover and the labor for removing the old paint would be an additional cost over blasting. This leaves the cost of the remover to compare with that of the sand, compressed air and maintenance of the blasting plant, which is also in favor of blasting. However, I have found the use of remover to be the next best method to sand-blasting.

#### DISCUSSION

John G. Gearhart (Penn. R. R.): Our sand house is now arranged so that two operators can work on a car at the same time, the car moving along past them.

H. M. Butts (N. Y. C. & H. R.): We expect to sand-blast everything that needs it, and are planning for a building that will contain two cars so as to prevent moisture accumulating on the cars before the priming coat is applied. We have experimented with paint and varnish removers of various kinds, but none are as effective as sand-blasting. We have sand-blasted one of our first-class vestibule cars with two men in five hours, but it takes on an average 7½ hours.

Other members stated that a car could be sand-blasted in 10 hours with a helper, and instances were mentioned where 60-ft. mail cars had been sand-blasted at a cost of \$9 a car. Regarding the number of times it is possible to use the sand, it was stated that it depends on its quality, and many have not found it possible to use it more than twice.

#### STANDARD FREIGHT CAR LETTERING

The standardizing of freight car lettering was strongly favored by the association, and many instances were mentioned where, on account of the lettering not being standard, considerable trouble had been caused. The following resolution was adopted in this regard:

"Whereas, The Master Car and Locomotive Painters' Association recognize the advertising value of the trade marks of the railroads that have been in use for years, and realize it would be useless for us to ask them to dispense with this invaluable medium of reaching the public, but

"Whereas, A uniform stenciling of freight cars is very desirable from the standpoint of shop efficiency and economy, and efforts have been made in the past, both by this association and by the M. C. B. Association, to accomplish this end, with more or less success; be it therefore

"Resolved, That we renew our efforts to arrive at this desirable end; and that we appoint a committee to design a series of letters and figures for this purpose, said committee to confer with the M. C. B. Association for its general adoption on all railroads."

#### OTHER BUSINESS

The secretary reported a membership of 292.

The following officers were elected for the ensuing year: President, T. J. Hutchinson, formerly of the Grand Trunk; first vice-president, H. Hengeveld, Atlantic Coast Line; second vice-president, John F. Gearhart, Pennsylvania Railroad, and secretary-treasurer, Alfred P. Dane, Boston & Maine. Detroit received the greatest number of votes for the next place of meeting.

LABOR CONDITIONS IN MASSACHUSETTS.—Labor conditions are the worst since 1908 in Massachusetts, according to the State Employment Bureau. In a single day, recently 3,000 people applied for work, with only 82 positions available.—*Iron Age*.

# RECLAIMING MATERIAL ON THE FRISCO

## Large Plant Established at Springfield for This Purpose Is Developing Surprising Results

The reclamation plant of the St. Louis & San Francisco, established at Springfield (Mo.) a little less than a year ago, has many features of special interest. In the first place, it is housed in what might be termed "scrap buildings on scrap property." This, however, is not nearly as bad as it sounds, for the buildings, at least the two main ones, are of substantial con-

struction and were originally built as the main shops of the Kansas City, Fort Scott & Memphis, but were practically abandoned when the new Frisco shops were built on the other side of the town several years ago. The plant is located about one-quarter mile south of the passenger station at Springfield. That part of the yard which is used for the unloading and

difficult task, but the moral effect upon the force, particularly in a plant of this kind, cannot but be felt in the results which are obtained from its operation as a whole. The scrap which is collected from the various divisions and shops is delivered to the reclamation plant at the rate of about 4,000 tons a month. The force required for handling and sort-



A General View of the Reclamation Plant of the St. Louis & San Francisco at Springfield (Mo.)

struction and were originally built as the main shops of the Kansas City, Fort Scott & Memphis, but were practically abandoned when the new Frisco shops were built on the other side of the town several years ago. The plant is located about one-quarter mile south of the passenger station at Springfield. That part of the yard which is used for the unloading and

ing it and carrying on the work of reclamation consists of about 255 employees. These are in direct charge of a superintendent, who reports direct to the chief purchasing officer, and include a general foreman, a dock foreman, an office staff of six men, a machine shop and air room force of 15 men; 14 men in the bolt shop, 37 in the blacksmith shop, five in the track material and



General View of Scrap Yard and Reclamation Plant

storage of scrap formerly consisted in large part of the low, uneven and eroded slope of a creek. This has been leveled and filled except for the channel bed and serves its purpose admirably, as indicated in the general views of the plant.

The buildings are kept well painted and a more or less successful attempt has been made to keep the plant in a neat and orderly condition. From the very nature of things this is a

frog shop, 14 in the carpenter shop, eight in the Oxweld department and about 150 in the miscellaneous force.

As the cars containing scrap arrive they are unloaded by a Brown hoist equipped with an electric magnet. The sorting is done by small gangs of men under the supervision of a foreman who thoroughly understands material. A large part of the scrap is of no use as far as re-application to cars and locomotives or



roadway is concerned and this is merely sorted into piles according to the class and grade and is again loaded on cars by the hoist and shipped and sold to scrap dealers. The remainder, possibly from 20 to 25 per cent of the total, furnishes the basis of the reclamation plant's profitable operation.

In developing this work of reclamation, it was recognized



A Group of Bolt Cutters in the Machine Shop

that it might easily be overdone and thus neutralize all of the gain which could be made if the efforts were concentrated on that part which might be reclaimed with profit. To guard against mistakes of this kind each item is carefully studied and analyzed and where there is any question as to the strength or durability of the part for the purpose for which it is intended, efforts are made to follow it into service. As all of the reclaimed metal parts are dipped in an asphaltum mixture before they are sent to the shops and storehouses, it is easy to spot them in the storehouse stock and to recognize them when they are replaced on

As may be seen from the photographs, the main buildings which house the machinery are located at one end of the scrap yard. The other smaller buildings, which have been constructed at a comparatively small cost from scrap lumber and old metal car roofs, are so located as to facilitate the movement of the various classes of material which they handle, cutting down lost motion and wasteful moves to a minimum.

#### BOLTS AND NUTS

All the bolts which are sorted from the scrap are sent to one of the smaller buildings, which is equipped with a shear and

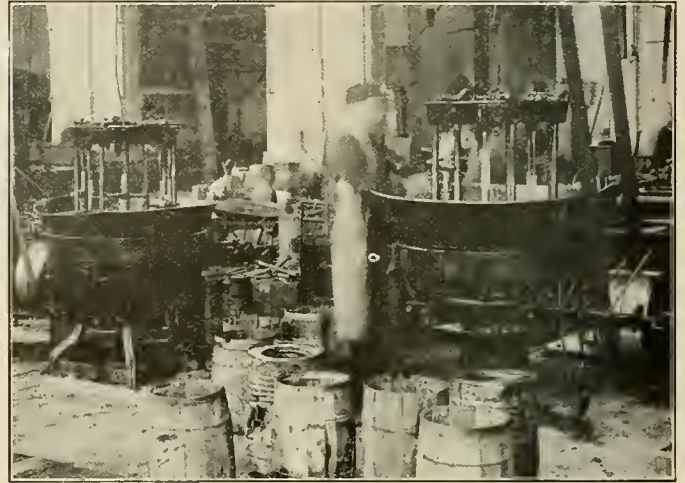

Two of the Multiple-Spindle Nut Tappers Which Were Reclaimed from Scrap

three small air operated hammers. The damaged ends are cut off and the bolts are straightened under the hammers. They are then sorted by diameters and lengths and are sent to the machine shop, where they are re-threaded. There is provided



Unloading Scrap With a Three-Ton Hoist Equipped With an Electric Magnet

cars and locomotives. It is thus possible to more or less readily locate any breakage or failure on a large scale of parts which have passed through the reclamation plant. The mechanical department officers are constantly on the lookout for possible cases of this kind.

for this purpose one single-head bolt cutter, three double-head machines and one triple-head machine. The scrap nuts are first annealed and are then placed in a rattler and cleaned; they are then sorted in sizes and retapped on four tapping machines, each of which is equipped with seven spindles. In all cases nuts are



screwed on the newly threaded bolts before they are sent to the storehouse. It is true that before the establishment of the reclamation plant, many of these bolts and nuts were reclaimed. It was a more expensive process, however, because the machines were scattered at the different shops and were not worked as efficiently as is possible where they are grouped together in one department and have a sufficient amount of work to keep them working to capacity at all times. In all cases it has been found possible to speed up the machines and thus increase the output.



Good Material Which Has Been Picked from Scrap for Future Use

Practically all of the work in the reclamation plant is done on a piece work basis.

A large number of new bolts and pins are also made from round iron which is taken from the scrap, straightened and cut to proper lengths. For the heading of these bolts two machines are used which were reclaimed from scrap. Practically all of

material cost, plus a proper allowance for supervision and overhead expense.

AIR BRAKES AND AIR HOSE

The main building, which contains the machine shop and the bolt and nut machinery, also has a section for repairing and cleaning air brake apparatus and for working over air and steam hose. The hose and fittings are first stripped with home-made devices; about 90 per cent of the fittings are practically as good as new when they have been cleaned and new gaskets have been applied. The greater part of the hose is useless, although a



A Pile of Shovels with Broken Handles and Bent Blades Is Shown at the Right and a Number of Repaired Shovels at the Left

certain proportion of it is fit for splicing and using on work equipment or for working over for dummy hose. In one month, for instance, 230 steam heat hose were overhauled, the old fittings being applied to new hose in most cases. In the same way 2,505 air hose were overhauled, 706 air hose were spliced and 53 dummy hose were fitted up.

In this department triple valves, angle cocks, relief valves and



Reclamation Plant Machine Shop

the bolts which are required on the railroad are now being reclaimed or made at the reclamation plant. During one month 157,082 machine bolts were reclaimed or made from scrap or new material at an estimated saving of \$1,953.50 as compared to the value of new bolts. This is on the basis of direct labor and

various other pipe and air fittings are overhauled and placed in a serviceable condition, often at a comparatively small expense. A typical month shows the overhauling and reclaiming of 247 angle cocks, 29 cut-out cocks, and 283 globe valves.

A large portion of this same building is used for the repairing



of damaged lanterns, markers, gage lamps, classification lamps, switch lamps, oil cans and other locomotive supplies. The item of locomotive supplies will probably not amount to a very large factor, however, because of the steps which are being taken by

three cars to make a new car. When this has been done and the car has been properly painted it is usually difficult to tell it from a new car. This is also true of baggage trucks, track drills, jacks, track levels and station skids. As an example, one month



Pneumatic Spike Straightening Machine

the mechanical department to standardize and give special attention to the proper use and maintenance of this material.

ROADWAY MATERIAL

A large part of the main shop is used for the rebuilding of damaged hand and push cars which are picked up and sent to



Crane and Vat for Immersing Reclaimed Material in Mixture of Asphaltum

showed the reclaiming of 23 track jacks, 45 hand cars, 6 baggage wagons, 48 warehouse trucks, 8 push cars, and 5 station settees, with an estimated saving of approximately \$1,000.

Another part of the shop, which is of more than ordinary interest, is that in which the shovels, scoops and scythes are re-handled and straightened up. This portion of the shop is shown in one of the photographs. The 12 in. shovels are cut back a

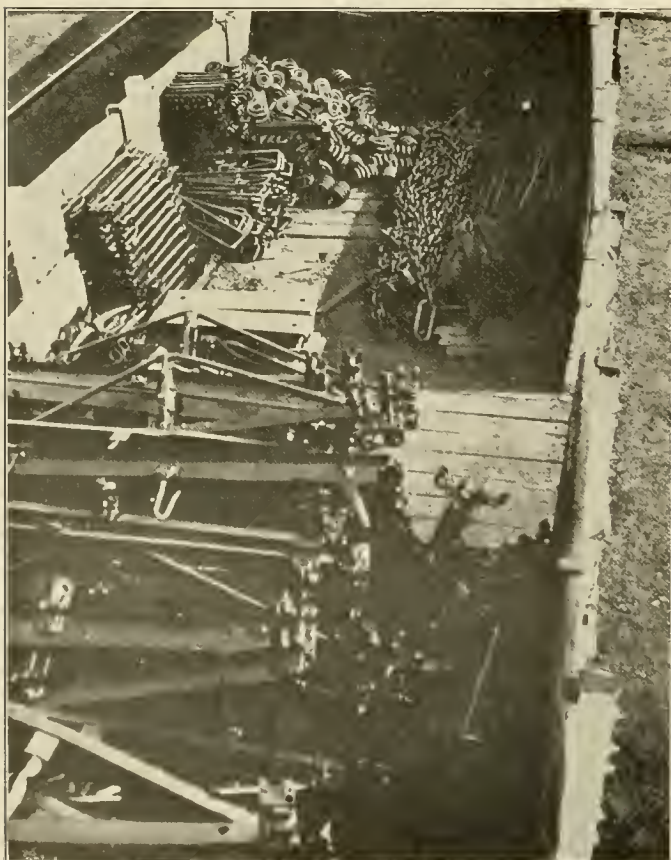

Part of Carload of Reclaimed Material Ready for Shipment to the Store Department

the reclamation plant as scrap. In some cases where the cars are badly damaged it may require the good parts from two or



The Oxweld Station at the Reclamation Plant

maximum of 2 in. About 90 per cent of the shovels which come to the reclamation plant in the scrap may be reclaimed in this way. A typical month shows the reclaiming of 418 track shovels with a saving of between \$90 and \$100.

Another special feature is that of cable repairs. A large amount of valuable material of this sort is lost on many roads because of the lack of an expert in splicing and repairing the

cables. Realizing this, the superintendent of the reclamation plant deliberately set out to locate a competent man to do this sort of work, preferably with experience in the navy. The result has been most gratifying.

**BLACKSMITH SHOP**

The blacksmith shop works over a large number of parts which come to it more or less damaged, and manufactures a considerable



**Welding Car Bolsters with the Oxy-Acetylene Process**

amount of material from scrap. It is showing a profit of from \$1,500 to \$1,800 a week. Track tools of all kinds, including adzes, spike mauls, clay picks, claw bars, lining bars and tamping bars are straightened and re-dressed. Broken coil springs are heated and drawn out with an air machine and are then made into jack bars, lining bars, drift pins and similar parts. A large shear is provided for shearing the coupler yoke rivets and



**Repairing Car Bolsters, a Journal Box and a Coupler with Oxy-Acetylene**

the good parts are reclaimed. A shear is provided for cutting bars and rods to length. A considerable number of brake rods are straightened and in many cases new ends are welded on.

The manufacture of material from scrap relieves the blacksmith shops at the different shop plants of much of this work. For instance, round iron is cut into suitable sizes and headed for bolts and made into pins; bar iron which comes to the plant as scrap is worked up into drawbar shims, carrier irons and other locomotive and car parts. One end of the smith shop is used for relining journal brasses. Exceptional results have been obtained by welding carbon steel points on picks. These have given good service and are said to be better than new tools.

**TRACK SPIKES**

Hundreds of track spikes are annealed and reclaimed each day. As these are sorted out from the scrap pile they are transferred to a small building which is fitted with a pneumatic hammer and is used only for the straightening of spikes. Such spikes as do not come up to a certain standard are, of course, scrapped, but the large number that can be reclaimed is surprising. Scrap washers after being rattled with the spikes, nuts, air hose couplings, etc., are treated in the same way.

**CEMENT SACKS**

Cement sacks used in connection with construction work are carefully gathered and forwarded to the reclamation plant.



**A Broken Coupler and a Similar One Which Has Been Repaired by the Oxy-Acetylene Process**

Usually these are torn and damaged from rough handling in opening; an old box car has been fitted up for handling these and one of the older employees gives all his time to sorting and repairing them. As many as 1,365 sacks were reclaimed in one month, resulting in a net saving of about \$84.

**OIL AND WASTE**

One of the smaller buildings is equipped with electrically driven centrifugal separators which thoroughly clean the soiled

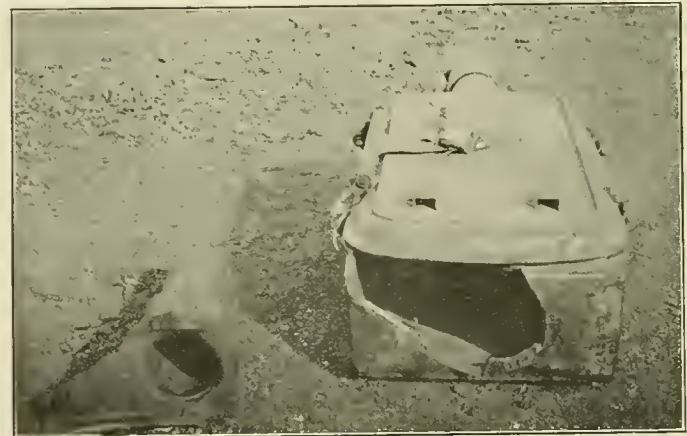

**Broken Signal Post and Relay Box Awaiting Repairs**

and oil soaked waste which has been taken from journal boxes, and also reclaims the oil. The net return from this department runs from \$200 to \$300 a month.

**BRASS SCRAP**

Special attention is given to the brass scrap because of its value, even as scrap. A small house has been built from old car timbers and metal car roofs which has a number of bins for the different



classes of brass, a scale being placed at the entrance to the building in order accurately to keep a check on all of the material.

BRAKE BEAMS

The reclaiming of brake beams is segregated in a small building because of the danger of flying rivet heads in stripping. All brake beams which are not too badly twisted or damaged

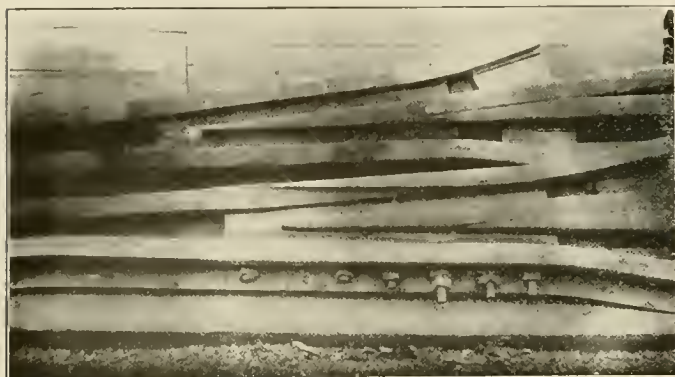

A Worn Crossing Frog and a Similar One Repaired by the Oxy-Acetylene Process

are straightened in a bulldozer and are refitted with new heads and fulcrum castings if necessary. Truss rods for these beams are made in the blacksmith shop from scrap material. Brake hangers which have been damaged or distorted are straightened and fitted for further use. In one month 1,692 brake beams were

cutting. The generating apparatus and the oxygen tanks, as well as the supply of carbide, are housed in a small building centrally located. The piping at the reclamation plant is entirely underground and consists of about 1,000 ft. each of pipe for oxygen



Cutting a Scrap Underframe, Thus Saving the Usable Parts and Securing a Higher Price for the Scrap

and for the acetylene gas. There are 12 outlets or stations on this line and at present a force of eight welding operators is kept steadily at work.



The Shop in Which Frogs and Switches Are Repaired and Reassembled

reclaimed with a saving of almost a dollar a beam, and 456 brake hangers were reclaimed.

ONWELD PLANT

Probably the most interesting part of the plant and that in which the most spectacular savings are made is that in which the oxy-acetylene process is used, either for welding or for

CASTINGS

One of the most interesting classes of work reclaimed by the oxy-acetylene process is that of castings, whether of cast iron, cast steel, brass or other alloy. Many brake cylinders or air reservoirs with broken lugs are repaired at a very small expense where otherwise it would be necessary to scrap the entire cast-



ing; even if the part which was broken off is not available it is possible in many cases to build up the casting with new material or to break a similar piece off of another scrap casting and weld



Old Boilers and Fireboxes Are Cut with the Oxy-Acetylene Burners Into Pieces Convenient for Handling

it in place. An important development which has been made necessary is a campaign of education among shop and engine house employees to emphasize the necessity of tying broken pieces

of castings, which may be reclaimed, together, so that time may be saved at the reclamation plant in supplying the missing parts.

The illustrations show typical jobs in the reclaiming of castings. As may be understood, the possibilities in this line are practically unlimited. Many cracked or broken car bolsters are welded and reinforced so that they are as good as new, and in some cases, even better. In possibly as many as 25 per cent of these cases the good ends of two badly damaged bolsters have been cut off and combined into one perfect bolster. Many couplers have been reclaimed which were cracked on the face or in the neck of the shank, or which have had broken knuckle pin bosses or lugs; in some cases repairs have been successfully made by filling in worn contours. One of the illustrations shows repairs being made to two bolsters, a journal box, a coupler and a center plate casting.

Locomotive buffer castings which have been broken or in which the holes have been worn out of round are reclaimed at a comparatively small cost. Many cast iron signal posts and relay boxes used in connection with the block signal system are repaired, the cost of welding usually varying between \$2 and \$3 per casting as compared to from \$16 to \$24 for a new part. A broken signal post and relay box which may easily be repaired is shown in one of the illustrations.

#### SWITCH AND CROSSING FROGS

A separate building, the interior of which is shown in one of the illustrations, is used for the repairing and reassembling of switch and crossing frogs. Ordinarily when these become worn they are rebuilt at a high cost. With the oxy-acetylene process the broken points and worn rails are built up to the original standard at a very small expenditure. As a typical case, a frog which costs \$45.25 new was reclaimed with an expenditure of \$7.50, making a net gain of \$37.75. One of the illustrations shows a frog which had become badly worn and a similar frog which



Old Locomotive Tanks Which Have Been Cut to Sizes Convenient for Handling.



had been just as badly worn, but which had been repaired with the oxy-acetylene process. In building up the rails and points the metal is applied over a small area at a time and is hammered down while hot, thus avoiding the necessity of subsequent machining.

#### REDUCING SCRAP

Several of the illustrations show large parts, such as old boilers, fireboxes, tender tanks and car frames, being cut up with the oxy-acetylene cutting burner. This class of scrap commands a very low price, not more than \$2.50 a ton. When it is cut into sizes for convenient handling it will bring at least double that amount; the cost of cutting is comparatively slight, so that there is a net gain of several hundred per cent.

#### THE SAVING

That the best results may be obtained at the reclamation plant it is necessary for the mechanical department officers over the entire system to understand the work which is being carried on there and to realize the possibilities of co-operation. It is proposed to have all of the master mechanics, roadmasters, general foremen and others who handle material pay periodical visits to the plant to study its workings and its possibilities. By seeing that parts broken from expensive castings are wired to them when they are forwarded to the reclamation plant they can help to increase the saving; in many cases they will send parts for repair direct to the plant rather than to let them take the roundabout method of going forward mixed up with a miscellaneous lot of scrap.

A careful record is being kept of all the work which is done at the plant with the idea of determining as accurately as possible the saving which results. Of course, these savings are not in all cases net, for much of the material, if it were not forwarded to the reclamation plant, would be reclaimed at the other shops on the system. There is little question, however, but that with the special organization at the reclamation plant the work can be carried on more economically and more thoroughly than it can at the other plants, allowing for the cost of transporting the material to and from the plant.

Statements are issued monthly showing the number of different parts reclaimed, the value of the new material used, the value of the scrap material used, the total labor cost, a charge for supervision and overhead expense, and miscellaneous shop expense. This in each case is compared with the cost of similar material purchased new and a column is added showing the total saving for each item and the saving per unit. The officers of the road have given the matter careful attention and thorough study, and are emphatically in favor of the plant. Started as an experiment, it was watched more or less critically with the idea that after all most of the saving might prove to be on paper; that this has not proved true is indicated by the fact that the work is gradually and steadily being extended and enlarged, although in many cases practices have been discontinued because it was found that it did not pay to try to reclaim certain parts. In making out the monthly performance sheet those items which do not show a saving indicate the loss in red and thus attention is focused on them. Needless to say an item showing up on the wrong side more than once or twice means either that prompt attention will be given in the attempt to reduce the cost of reclamation, or no further work will be done on such parts. The plant is in charge of Superintendent R. F. Whalen.

**NEW METHOD OF MEASURING DISTANCE.**—An ingenious artist has invented an instrument termed a distance register, capable of being applied to two and four-wheel carriages of every description, for the purpose of ascertaining the ground gone over by such carriages in any given space of time, from one minute to the whole day, and which may be employed with equal efficiency in reckoning the course of either steam or sailing vessels.—*From American Railroad Journal, August 22, 1835.*

## BURNING OUT OIL DEPOSITS IN AIR PUMPS\*

BY W. M. ROBERTSON,

Engine House Foreman, Illinois Central, Harahan, New Orleans, La.

Until recently the methods used for removing the deposits of oil from the air end of air pumps without removing the pump from the engine were very impractical and unsatisfactory. The job meant dismantling the pump at the air end, tearing out all the valves and scraping out the parts by hand. The work was never done thoroughly, it required much time to do it and then there was always the danger of delaying the engine.

This work was revolutionized by the introduction of oxygen carbon removers. This outfit does the work thoroughly and in a very short time. The outfit shown in the illustration will remove every small particle of oily deposit from the valves and other parts. The action is purely chemical and requires no taking down of the pump.

With an oxygen cleaner a pump cylinder can be thoroughly cleaned in ten minutes. This means that it is never necessary to tie up an engine to clean the air pump, and when cleaned in this manner the life of the pump is greatly increased.

The oxygen cleaner consists of an automatic regulating reducing valve fitted with a thoroughly tested gage and about 8 ft. of high-grade hose with 2 ft. of  $\frac{1}{8}$ -in. copper tubing reduced to



Burning Out Oil Deposits in Air Pumps

about  $\frac{1}{16}$ -in. on the point, and a  $\frac{1}{8}$ -in. needle valve at the hose. One of the valves is removed and the opening swabbed out with headlight oil. A small piece of waste is then ignited and dropped in the opening, when the torch is inserted and the oxygen turned on, the oily deposit being rapidly burned away. Only a few minutes is required to burn the heaviest deposits. As soon as the deposit is consumed the burning ceases as the gases have no effect as soon as the cylinder is cleaned.

Where an oxy-acetylene welding plant is used, it is only necessary to have a hose and torch to connect to the regulating valve of the standard welder. The material necessary to make the outfit consists of an auxiliary reservoir, a signal line reducing valve, 8 ft. of  $\frac{1}{4}$ -in. hose, 24 in. of  $\frac{1}{8}$ -in. copper tubing, one  $\frac{1}{8}$ -in. needle point valve and a duplex air gage.

**INCREASING THE EFFICIENCY OF THE CUTTING TORCH.**—Experiments recently conducted in cutting with oxy-hydrogen and oxy-acetylene cutting torches show that a marked increase in the rate of production is effected by increasing the temperature of the oxygen. The most favorable results secured in this connection show that the increase of speed obtained by preheating the oxygen is 18 per cent, while the saving in the amount of oxygen used was 55 per cent.—*Machinery.*

\*Entered in the competition on Engine House Work, which closed July 15, 1914.

# NEW DEVICES

## RECENT DESIGNS OF ENGINE AND TENDER TRUCKS

The change in wheel arrangement, together with increased size and weight of the modern locomotive, has imposed a duty upon the leading truck of the prevailing design out of all proportion to its guiding capacity. As a consequence the work

tion bolster device for locomotive trucks which, it is claimed, will meet these exacting requirements more fully than the three point link suspension which heretofore has been almost universally used. In principle it provides a constant resistance regardless of the lateral displacement of the bolster instead of a low initial resistance increasing with the lateral displacement, as is obtained with the three point suspension links. Variations, such as high initial resistance, with a constant resistance follow-

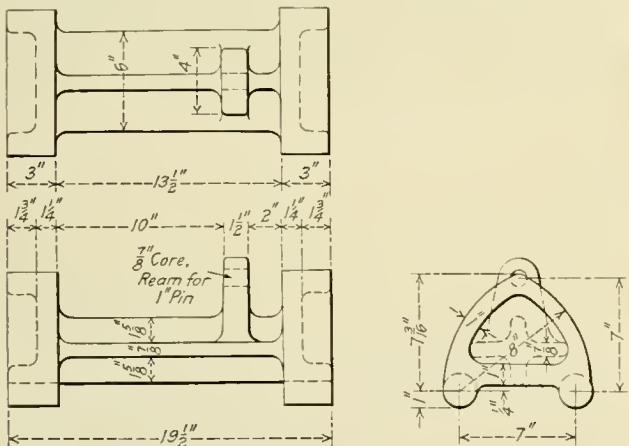

Rocker Used in the Engine Truck

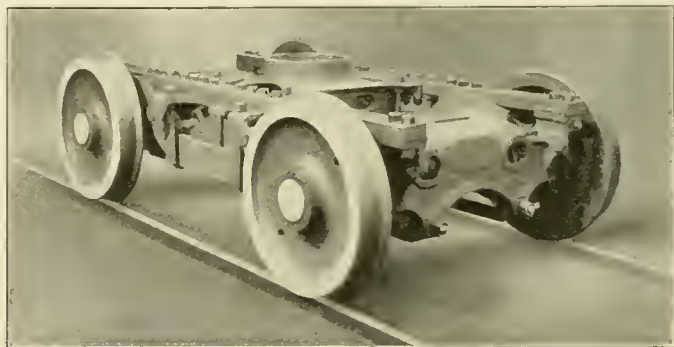

Engine Truck Designed to Provide Constant Resistance Regardless of the Lateral Displacement of the Bolster

which should devolve upon the truck consistent with the load carried at the centerpin has been, to a considerable extent, taken up by the leading drivers, resulting in lack of stability on tan-

ing a predetermined bolster movement, can be obtained by slight modification of the surfaces in contact. One of the illustrations shows the heart shaped rocker in detail. The swing bolster bears directly on these rockers which are connected to it by links to insure their remaining in the proper position.

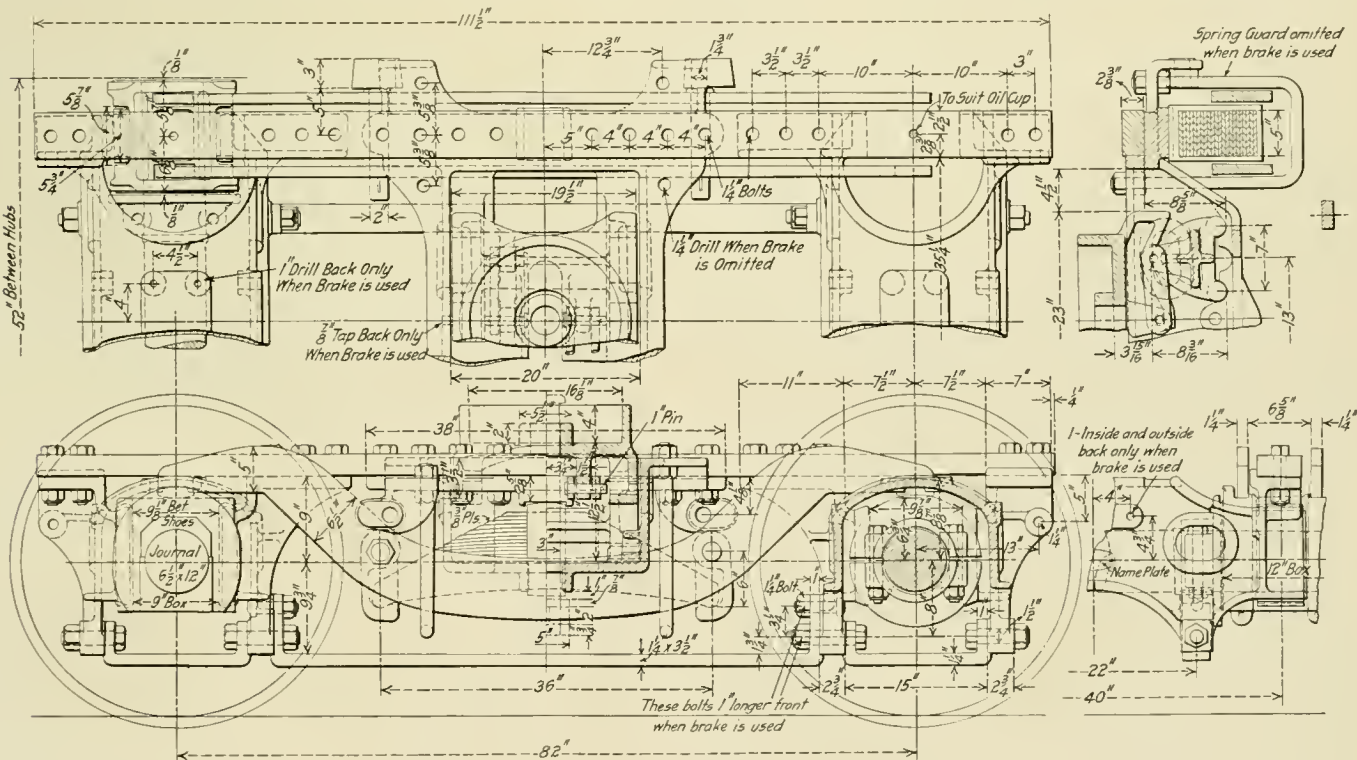

Arrangement of the Constant Resistance Engine Truck

gents and excessive wear of the flanges of leading driving wheel tires.

Service results with this truck show a marked reduction in the flange wear on leading drivers, a steadying action while running on straight track, an absence of jerky motion on curves and

These conditions have led to the development of a lateral mo-





## PORTABLE STEAM STERILIZER

The accompanying illustration shows a portable steam boiler for sterilizing drinking water coolers in passenger cars as provided by law. It is sold by the West Disinfecting Company, 12 East Forty-second street, New York City. It consists essentially of a steam boiler of 10 gal. capacity, which is heated by a kerosene vapor flame from three Lovett Giant flash burners in a tank under the boiler. The boiler is well lagged with two thicknesses of asbestos, that next to the boiler being composed of soft fiber and that next to the jacket being asbestos mill board. The jacket extends below the boiler and forms the furnace within which the oil tank is placed.

The boiler is constructed of galvanized steel, the joints being welded by the oxy-acetylene process. It is built to stand a test of 200 lb. steam pressure, which gives an ample factor of safety for the working pressure of 40 lb. to 50 lb. The fuel tank is also built of galvanized steel in the same manner, to withstand a test pressure of 75 lb., the actual working pressure being about



Steam Sterilizer for Water Coolers

7 or 8 lb., which is secured by means of a hand pump incorporated in the construction of the tank.

The device is mounted on wheels so that it may be easily moved from one car to another throughout the yard. The steam is taken from the top of the boiler and is discharged through a  $\frac{1}{8}$ -in. outlet into the cooler, which is turned upside down over the outlet, as shown in the illustration. With this sterilizer one man has sterilized 157 coolers from 34 cars in eight hours, using 4 gal. of low grade kerosene costing approximately 5 cents per gallon, and 16 gal. of water. In this specific case the cost of labor for performing this work was \$1.52. To do this work it was found necessary to refill the boiler four times, and to replenish the burner twice. The boiler is easily filled by simply removing the nozzle from the end of the discharge pipe, placing a water hose thereon. The water is then turned on and allowed to pass into the boiler in this manner, the top gage cock being opened to provide the necessary vent. In this way it is

not necessary to draw all the steam off the boiler nor to extinguish the fire. When being filled in this manner only 15 min. is required to raise the pressure sufficiently high for operation. On starting up in the morning, however, 30 min. is required to bring the boiler up to a working pressure. Tests have shown that it is only necessary to sterilize the coolers by this method for one minute, very satisfactory results being obtained in this time.

While the number of coolers that can be handled by one man has been found to be about 160 per eight hours, it is believed that two men would be able to handle between 250 and 300 coolers in the same time if necessary. The roads using this system have found it more satisfactory than the yard steam line system. Dryer steam is obtained, and where these machines are in service the yard steam line has been discontinued entirely, thus eliminating the losses due to condensation. It is also estimated that this device will save from 25 to 30 per cent in the cost of labor for sterilizing the water coolers. Each sterilizer is provided with a steam gage, water glass, three gage cocks, washout plug and safety valve. The whole device weighs 325 lb. when loaded for operation.

## PORTABLE ARC WELDER

A portable arc welder, having all the features of the larger stationary equipments, has been designed by the C. & C. Electric & Manufacturing Company, Garwood, N. J. The equipment is extremely flexible for welding and repair work in ship yards, machine shops, locomotive shops and foundries. The motor circuit may be connected to any available part of the shop or yard circuit.

The equipment, consisting of dynamotor, control apparatus and switchboard, is supported on a base of I-beams and mounted on a heavy iron truck. The welding current is generated by a 110-volt dynamotor, the generator end having a capacity of 200 amperes at 70 volts. The motor shaft is extended to receive a pulley for belt drive, when in use on barges, in shop yards or where electric current is not available. As illustrated, the starting box and field control rheostat are mounted on the frame structure supporting the switchboard. The switchboard carries

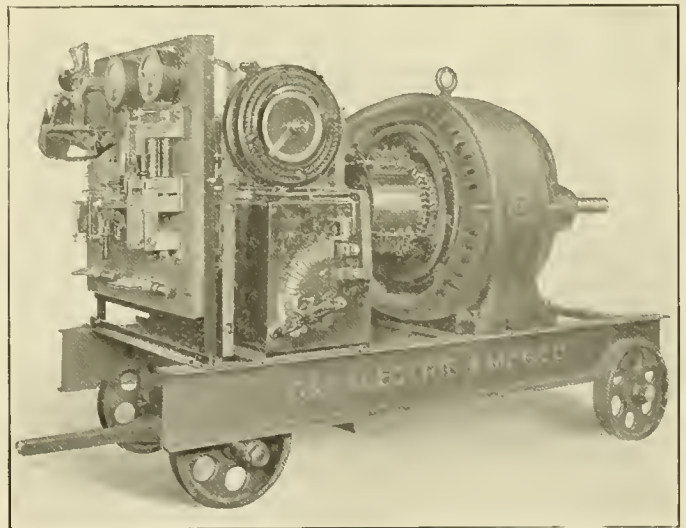

Complete Portable Equipment for Electric Welding

the main line switch and circuit breaker for the motor, and automatic control relays for two individual welding circuits. A set of 400 amperes will provide for one graphite electrode or two metallic electrodes for welding. The graphite electrode gives a temperature of about 4,000 deg. C., and is used for cutting, pre-heating and welding with an auxiliary bar. The metallic welding electrode furnishes the welding metal directly and can be



used on vertical or overhead work. The automatic relays in each welding circuit insert and cut out small steadying resistances on drawing the arc, and thereby prevent burning of the metal. Automatic devices also prevent interference between operators. An ammeter in the welding circuit permits the accurate adjustment of the current to the work.

### STRUCTURAL STEEL TENDER TRUCK

A structural steel tender truck of the equalized pedestal type has recently been introduced by the Canadian Locomotive Company, Ltd., Kingston, Ont. The construction has been developed and patented by Messrs. Casey and Cavin, with the view to increasing strength and durability, and at the same time effecting a considerable reduction in weight.

Owing to the inherent tendency to internal strains and shrinkage cracks which exists in cast steel bolsters, much trouble has been experienced on many Canadian roads with the present type of equalized pedestal truck. In order to preserve an adequate factor of safety the bolster castings are necessarily much heavier than they would be if a more reliable material were used. The

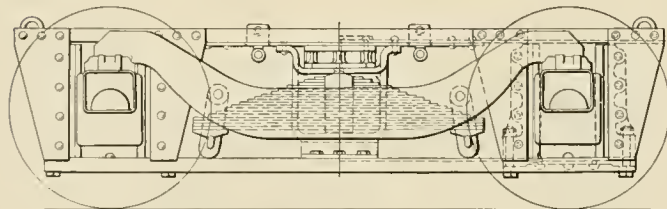
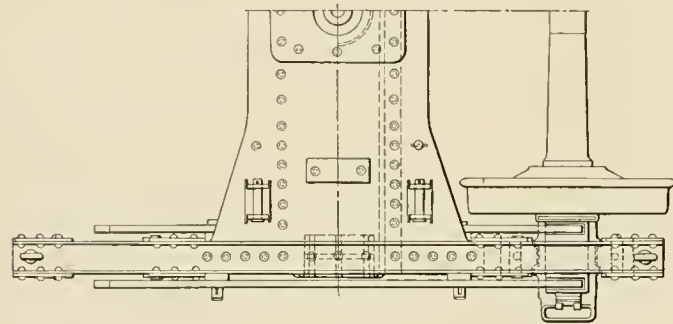
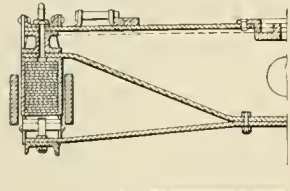

Structural Steel Pedestal Tender Truck

new truck is built up, with two exceptions, entirely of rolled sections in which the strength of the material is uniform and definitely known. The bolster is of pressed steel flanged with a deep section at the center and decreasing in depth toward the ends. It has a large cover plate hydraulically riveted to the flanges at the top. The ends of this plate, which are secured to the side frames are considerably wider than the bolster, thus forming a strong diagonal bracing for the whole truck structure. Apertures are provided in the cover plate for the center casting and brake hangers. The hangers are supported from lugs punched and bent from the cover plate and forming an integral part of it. Both the top and bottom rails of the side frames are of channel sections and are connected by plates which form the pedestals for the journal box. The ends of the bolster at the spring seat are stiffened by light cast steel fillers inserted between the bolster and cover plate.

Owing to the limited space between the spring and equalizers a drop forged T-head hanger has been substituted for the usual type of U-hanger used on this type of spring suspension. These hangers extend through slots in the ends of the springs and are

held in position by gibs in the manner commonly used in driving spring suspension. The saving in weight effected by this construction is claimed to be about 1,500 lb. per truck, making a total of 3,000 lb. reduction in dead weight per tender.

### REFLEX WATER GAGE WITH METAL ENCASED GLASS

A reflex water gage, the glass of which is contained in a soft metal casing, sealing the edges against the action of steam and water, has been developed by the Prince-Groff Company, 50 Church street, New York. It is called the "Pressurlok" and, as shown in the illustration, the design includes the lamp and all fittings by which it is attached to the boiler. The frame, which is a one-piece steel casting, contains two chambers, running parallel to each other, which are connected by ports at the top and bottom. The registering column contains the sight glass and communicates directly with the boiler through the water connection, which enters the well at the lower end of the column. The auxiliary

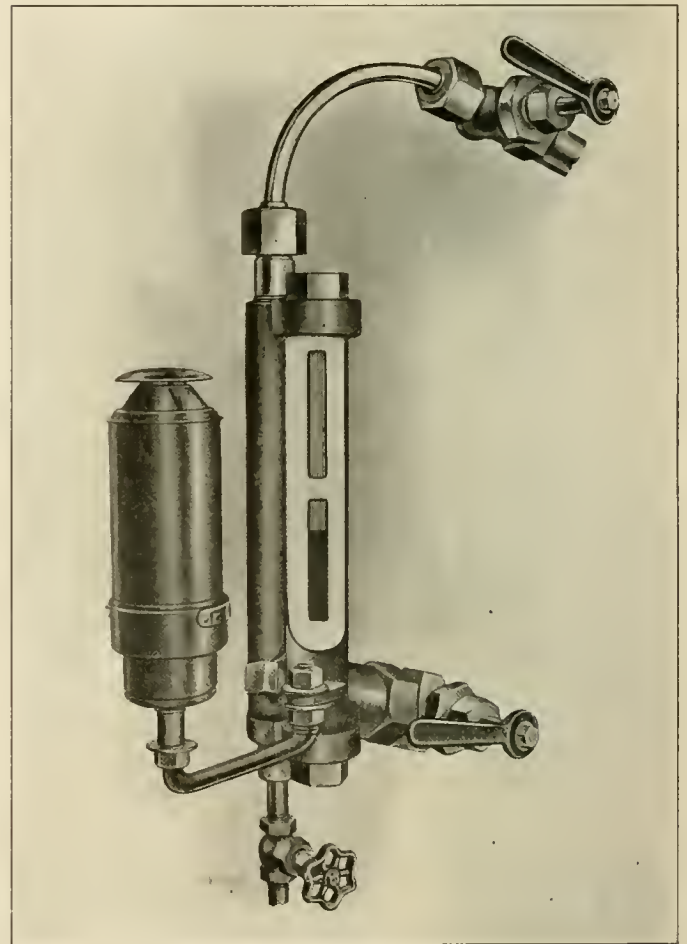

Reflex Water Gage with Metal Encased Glass

column receives the steam connection, thus protecting the reflex surfaces of the glass from erosion when steam is blown through the gage. Large plugs seating against copper gaskets close the top and bottom of the registering column.

The reflex glass is held in place by means of a backing piece bearing against the soft metal casing on the back face of the glass. Horizontal and vertical sections through the backing piece are shown in the engraving. Pressure is exerted against the backing piece by a single set screw acting against a heavy single leaf spring, thus insuring a uniform bearing

pressure at all points between the backing piece and the glass, as well as between the glass and the frame. The joint between the glass and the frame is sealed by the soft metal casing which forms a gasket unaffected by steam or hot water. The joint between the backing piece and the glass is sealed in the same manner and all portions of the glass

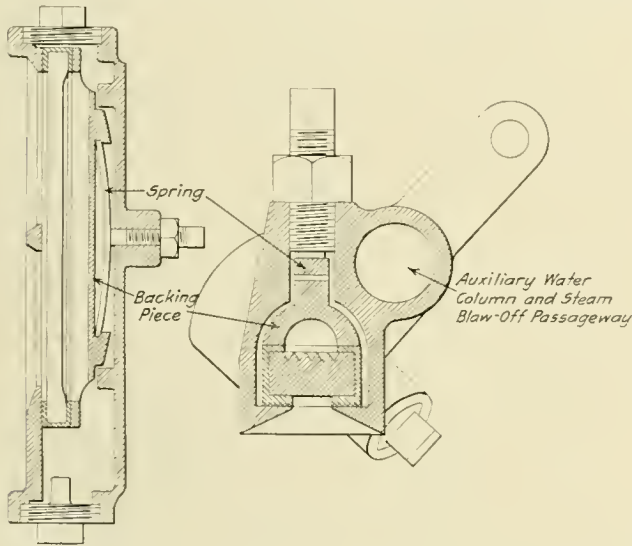

Sections Through Registering Column of "Pressurlokd" Water Glass

except the reflex surfaces are entirely free from contact with steam or water. It is claimed that by this construction should the glass be cracked or broken into several pieces the external pressure against the metal casing around the edge of the glass locks the pieces together so that it is impossible for them to be blown out of the frame. Glasses

sages through the backing piece shown in the longitudinal section.

The boiler fittings are designed for uniform strength throughout. All joints are sealed by means of copper gaskets. Plug cocks are used, thus providing straight passages which are easily kept clean. Owing to the fact that pressure on the metal casing holds the glass in position when it is broken, it has not been considered necessary to restrict the size of passages to meet the requirements of safety. In order to reduce to a minimum the probability of false indications from plugged passages 9/16 in. openings have been provided throughout. The auxiliary water column provides the additional steadying capacity required by the larger size boiler connections. A cleaning plug is provided in the frame directly opposite the water connection at the bottom of the registering column. A special tool has been designed for insertion in place of the plug, by means of which the passageway may be cleaned while the boiler is under pressure. The glasses are readily renewed by removing the cap at either the top or bottom of the frame.

### DOUBLE SPINDLE LATHE

For a number of years a double spindle lathe has been built by J. J. McCabe, 30 Church street, New York, which has met with considerable favor in roundhouses and small railway repair shops. This machine has been recently redesigned to meet the requirements of modern high speed tool steel and a number of features especially adapted for service in railway shops have been included in the new design.

The new lathe has a 48 in. triple geared spindle for large work and a 26 in. back geared spindle for general use on small work. The spindle of the upper swing has been enlarged considerably and by the use of the internally geared face plate a ratio of gear-

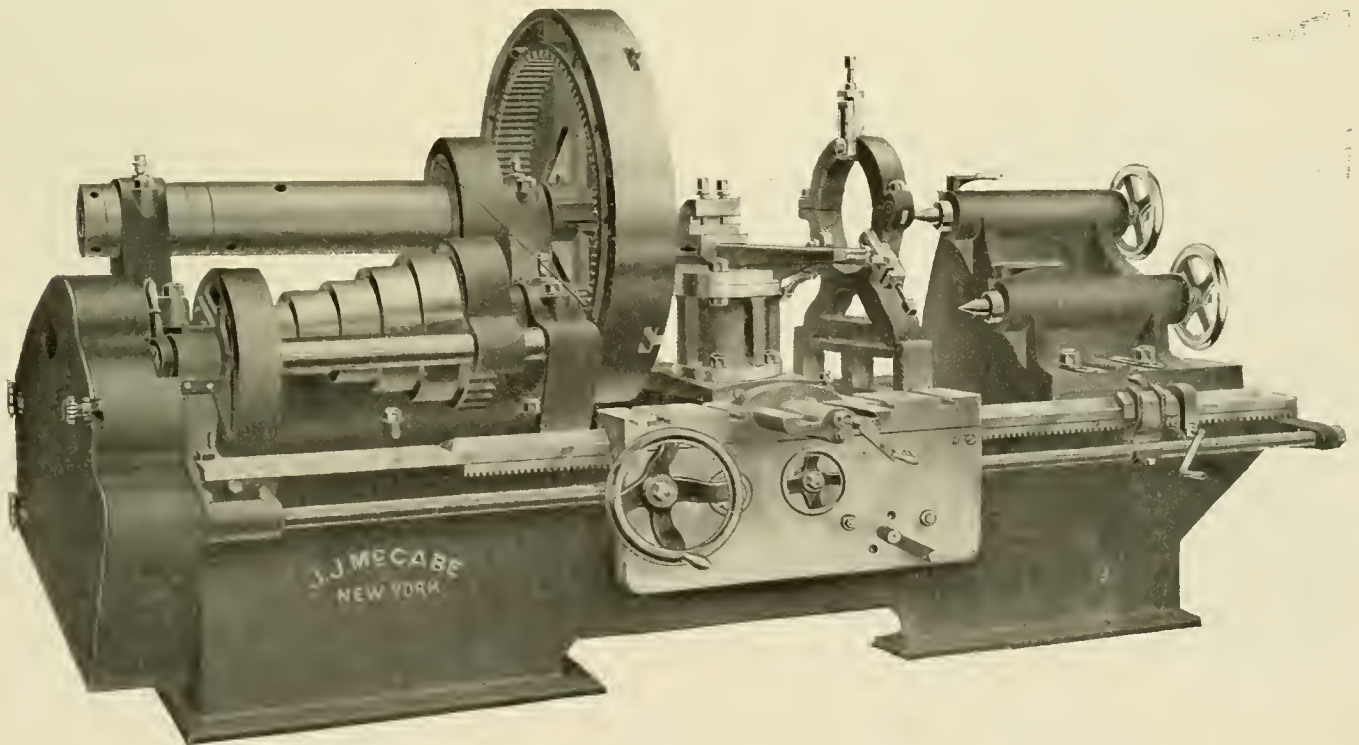

Double Spindle Lathe, Showing Geared Face Plate in Position on Upper Spindle

which have broken in service are said to have been held in place in this manner while the engine completed its trip without the necessity of cutting out the gage. Access for water and steam to the back of the glass is secured by means of pas-

ing of 72 to 1 has been obtained. It is claimed that ample power has thus been obtained to fully meet the requirements of tire turning with modern tool steel. The back gear for the lower spindle has been located on the front of the machine, thus tend-



ing to throw the strain on the spindle downward instead of in an upward direction as is the case where the back gears are located at the rear of the head. The bed has been widened and much increased in rigidity by extending it to the floor. To facilitate the turning of wheels a special wheel holding attachment has been designed, consisting of two driver arms and a socket plate

rigid block having a long cross bearing on the lathe carriage, curved to clear the wheel.

These machines are built in a standard size for stock, all parts being interchangeable. It is possible, therefore, to turn them out at a moderate cost. The beds are furnished 16 ft. in length and will turn 10 ft. between centers. If desired, however, beds of any length can be furnished.

### LOCOMOTIVE BY-PASS DRIFTING VALVE

A locomotive by-pass valve so arranged that during periods of drifting a small supply of live steam from the boiler is automatically fed to the cylinders has been developed on the

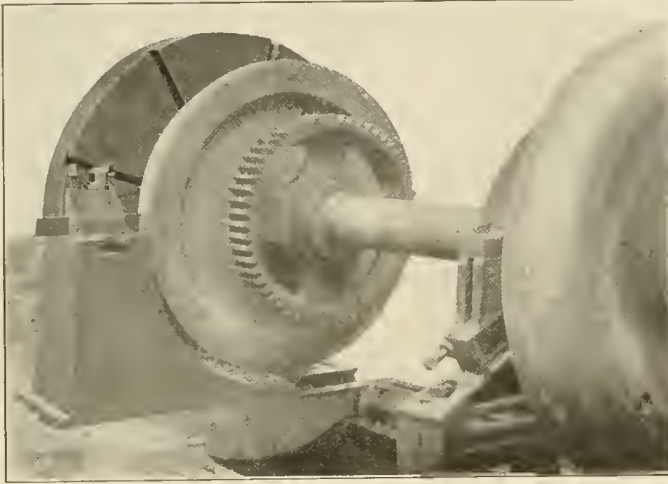

Special Tool Rest for Turning Wheels and Tires

attached to the face plate of the upper spindle. The wheel is centered by means of a three piece conical bushing which surrounds the journal. The outside conical surface of this bushing fits a corresponding inside surface in the socket plate, thus wedging the bushing against the journal and securely holding it against the pressure of the tool.

The swing may be increased to 54 in. or 60 in. by means of

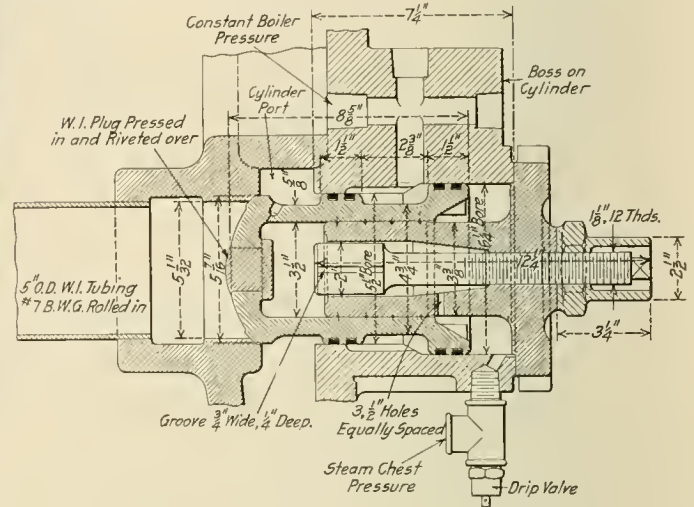

Section Through By-pass Drifting Valve Chamber

Delaware, Lackawanna & Western and was recently patented by H. C. Manchester, superintendent of motive power and equipment, and S. S. Riegel, mechanical engineer. These

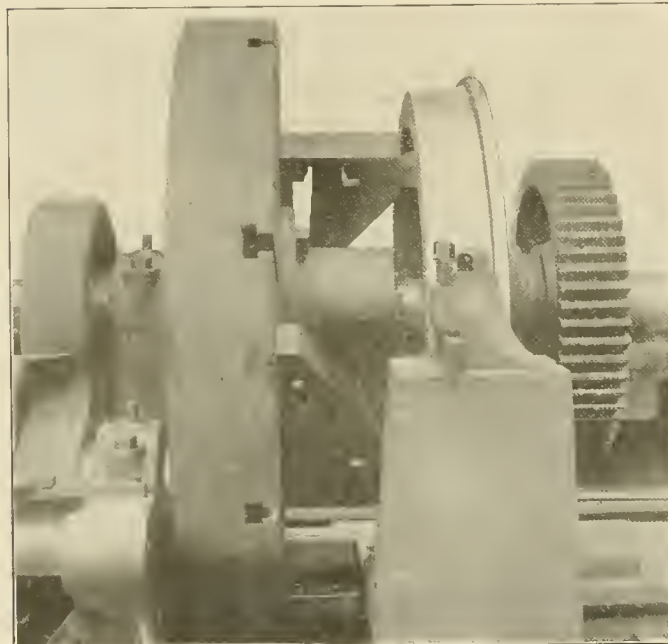

Socket Plate and Driver Arms for Centering and Driving Mounted Wheels with Outside Journals

specially designed raising blocks which can be placed under the head and tailstock of the machine when it is desired for use in turning small driving wheels. In order that the crank pin may clear the face plate, the lathe center is placed in a socket plate attached to the center of the face plate, which extends the center a sufficient distance from the face plate to allow the crank pin to clear. A heavy tool rest has been designed for wheel and tire turning. As shown in one of the illustrations, it consists of a

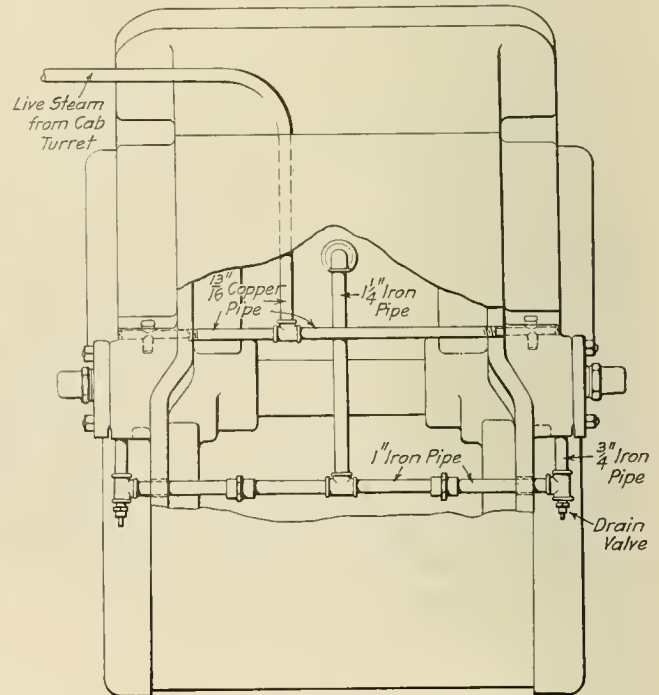

Steam Connections to By-pass Drifting Valves

valves are of the piston type, operating in chambers opening into the ports between the valve chamber and cylinder. The two chambers at the opposite ends of each cylinder are con-

ected by a 5 in. wrought iron tube which forms the by-pass connection when the engine is drifting.

The operation of the valve may be followed by referring to the drawing showing a sectional view through the valve and its chamber. The valve, which is in the form of a hollow cylinder, is guided by a cylindrical extension on the valve chamber cap. It closes the by-pass at its inner end. An annular chamber surrounding the valve near its outer end is formed by two sets of packing rings, the outer set operating in a chamber 6 1/4 in. in diameter, while the inner set is 5 1/2 in. in diameter. A 13/16 in. copper pipe leading from the cab turret provides a constant supply of live steam to this chamber. The space between the valve cap and the outer end of the valve is at all times in communication with the live steam cavity of the valve chamber. When the throttle is open the pressure in this chamber acting against the entire area of the valve holds it in the position shown in the drawing. When the throttle is closed this pressure is relieved and the live steam pressure in the annular cavity, acting against an effective area equal to the difference in area of the two pistons,

of stroke is adjusted by means of a rod threaded through the center of the head.

Engines equipped with these valves are claimed to be very easy coasters. Sufficient live steam is furnished to break up the vacuum during coasting periods, and the use of live steam tends to prevent chilling of the cylinder walls. By preventing the inrush of air, carbonization of the oil in the cylinders is eliminated, a matter of importance on superheater locomotives. These valves are claimed to have effected a great increase in the life of cylinder and piston rod packing.

### GRAVITY BOILER WASHING SYSTEM

The purpose of all hot water locomotive boiler washing systems is to reclaim the greatest possible amount of heat from the blow-off in order that hot water for washing and filling may be obtained with a minimum expenditure of live steam. In the Winters gravity system of locomotive boiler washing the material used in the construction of the plant has been chosen and

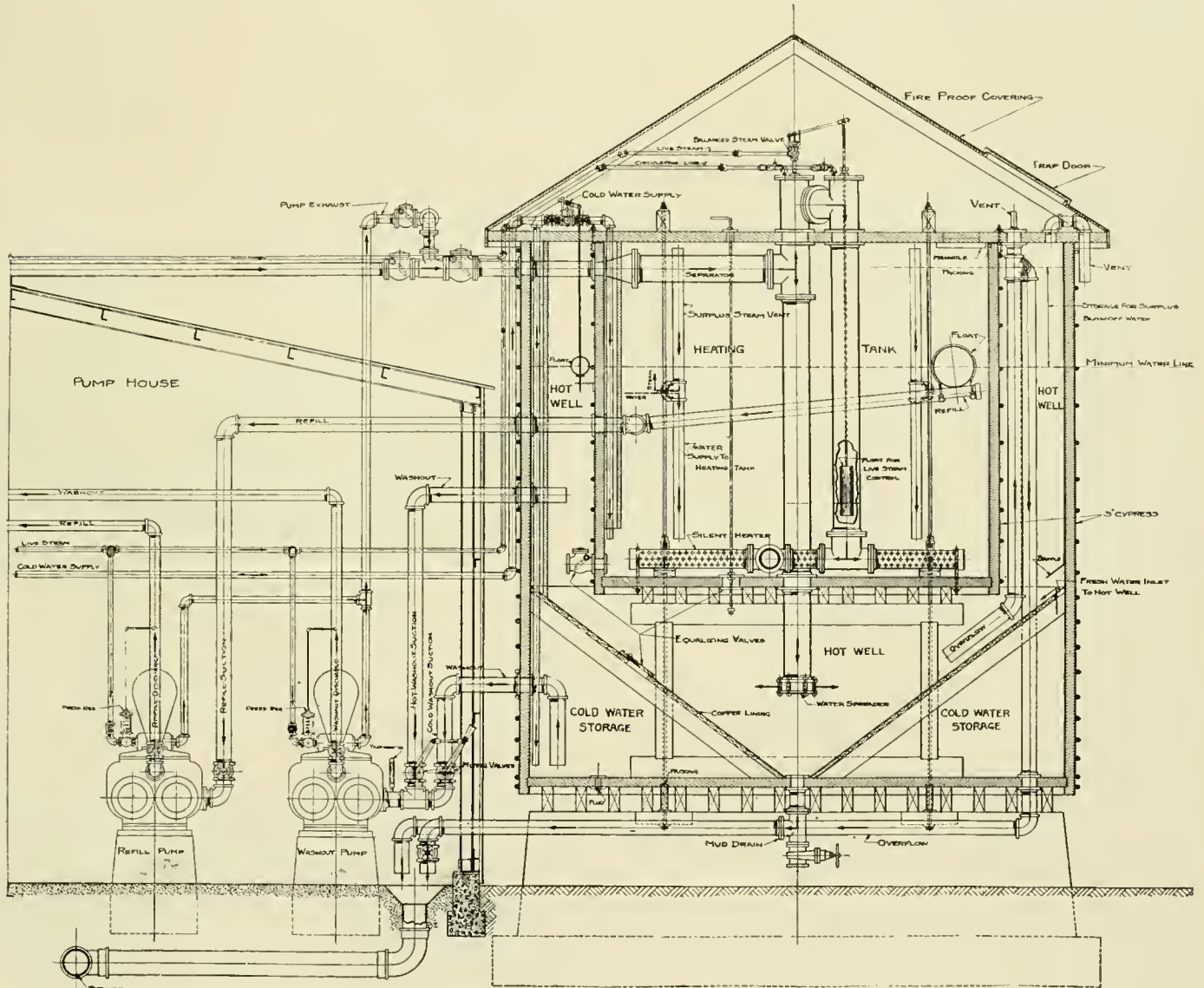

Hot Water Boiler Washing and Filling Plant

forces the valve open. In doing this the inner piston over-travels six grooves leading from the annular chamber, thus allowing live steam to enter the cylinder. The construction of the valve is such that its operation in opening and closing should not be accompanied by a serious shock. The length

the tanks have been arranged with especial attention to the conservation of heat. This system, which is being placed on the market by the George M. Newhall Engineering Company, Philadelphia, Pa., is shown in the accompanying engraving.

The plant consists of two standard 3 in. cypress tanks, one



submerged within the other. The outside tank forms the hot well into which the locomotives are blown off, the inside tank containing water for refilling. The hot well is equipped with a copper lined hopper bottom which guides the mud deposited from the blow-off water to a central opening leading to the mud drain. The tank below the hopper bottom forms a cold water storage, the supply for which is controlled by a float operated valve. Both tanks are tightly closed at the top, the only communication with the atmosphere being through the vent in the top of the hot well. A separator is located within the refilling tank. It consists of an inverted U composed of two large vertical pipes of unequal length; the longer pipe extends through the bottom of the refilling tank into the lower part of the hot well while the shorter pipe connects with a silent heater located in the bottom of the refilling tank.

When a boiler is to be washed out the blow-off cock is attached to the blow-off line in the roundhouse and the boiler blown down in the usual manner. The water and steam from the locomotive enter the hot well side of the separator near the top of the refilling tank. The water flows by gravity into the hot well, while the steam accumulates in the separator forcing the water down in both pipes until an outlet is secured through the heater. When the water in the heating or refilling tank reaches the boiling temperature steam will no longer be condensed, but will pass up through the water and accumulate in the top of the tank until an outlet has been forced to the hot well through the surplus steam vents. No steam can be discharged to the atmosphere until the water in the upper portion of the hot well has reached the boiling temperature.

Starting with the cold water supply it will be noted that fresh water for the hot well is drawn from the warmest portion of the cold water storage and that the water supply for the heating tank is drawn from the upper part of the hot well where the cleanest and warmest water is located. The inlet to the refilling suction is attached to a float so that the hottest water in the plant is used for refilling purposes.

In designing these tanks a water capacity of 5,000 gal. is provided for each locomotive washed in 24 hours in order that the plant may have ample capacity to take care of unusual sequence in the operation of blowing down, washing out and refilling. In effect it assures a 24-hour supply of hot water for washing out and refilling before any blow-off steam can be wasted at the vent. Sufficient capacity is provided above the minimum water level so that the plant may receive the blow-off from a number of engines before there is any loss of heat at the overflow, which draws from the lower part of the hot well. In order that the temperature of the heating tank may be maintained at all times the separator is provided with a live steam connection. Steam admission is controlled by a float operated valve, the float for which is located in the heater side of the separator.

A 30-day test has recently been completed by the Central Railroad of New Jersey on a Winters plant installed at its Communipaw engine terminal at Jersey City. The guarantee under which this plant was installed requires that it maintain average refilling temperatures of not less than 180 deg., and average washout temperatures of not less than 130 deg. without the use of live steam, the blowing down pressures to average 125 lb. per sq. in. Exhaust steam is received from the washout and refilling pumps, but during the test the live steam connection was removed. The plant has a total water capacity of 60,000 gal., 30,000 gal. of which is in the hot well, 18,000 gal. in the refilling tank and 12,000 gal. in the cold water storage. The operating conditions are such at the Communipaw terminal that four or five engines may be blown down before any washing is done. The engines are then washed out and refilled before the plant receives any more hot water from the blow-off line. The following is a summary of the test results:

Total number of locomotives handled.....	169
Average boiler pressure at time of blowing down.....	91 lb.
Average temperature in the hot well at the washout suction.....	193 deg.
Average temperature at which locomotives were refilled.....	213½ deg.

Average time of blowing down (through 1¼ in. blowoff hose into 1½ in. iron conduit) .....	60 min.
Average time of washing out.....	42¾ min.
Average time of filling.....	26 min.
Average time of firing up to 100 lb. gage pressure.....	52 min.

The wash-out pump suction has two branches, one from the hot well and one from the cold water storage, the temperature of the wash-out line being determined by means of a regulating valve easily adjusted to maintain any temperature required. The average time of firing up to 100 lb. gage pressure includes the time consumed in laying the fire which was also coincident with the time taken for refilling, these two operations being performed at the same time. The time required for the entire operation therefore averages 2 hr. 34 min. The comparatively long time taken for refilling may be accounted for by the fact that the pump was handling water boiling under two or three pounds pressure, the pump suction therefore receiving a mixture of hot water and steam. This is compensated for, however, by the speed with which steam is generated from water already at the boiling point.

The operation of the plant as described provides for the return of blow-off water to the refilling tank and thence to the boiler. In bad water districts where this practice would be inadvisable arrangements may be readily made to supply only clean water to the refilling tank. To do this the water supply connections between this tank and the hot well are removed leaving only the surplus steam vents, and cold water is fed to the refilling tank through an independent float valve installed for that purpose.

### MALLEABLE IRON WELDED BY OXY-ACETYLENE

A method of welding malleable iron by the oxy-acetylene process has been perfected by the Vulcan Process Company, Minneapolis, Minn.

The accompanying illustrations show how a broken clamp was thus repaired. After being welded, the clamp is shown

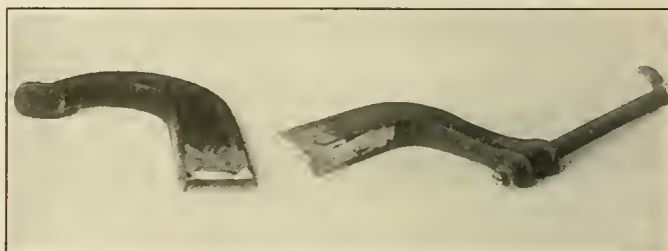

Clamp Prepared for Welding

bent sidewise at an angle of 45 deg. with no rupture in the weld. In small objects the parts to be welded are beveled off on one side, the bevel extending clear across the break. The two parts are then heated to a bright red heat with the torch and the surface to be welded is sprinkled with the



Clamp Welded by Oxy-Acetylene and Bent 45 Deg. Without Rupture

Vulcan bronze flux, after which is added a small quantity of Tobin bronze melted from the stick by the oxy-acetylene torch. The action of the bronze determines whether the parts are hot enough for welding; if it readily adheres to the

surface of the iron the work is ready and the break should be filled in as quickly as possible. Care should be taken to keep the temperature as low as consistent to get a satisfactory weld. In larger work the fracture is V'd out on both sides and handled in a similar manner. Welds thus made have nearly the strength and ductility of the original metal.

### CORRUGATED STEEL DOOR WITH FENDER ATTACHMENT

A corrugated steel box car door which is being manufactured by the American Car Roof Company, Chicago, is fitted with a fender attachment to prevent the doors being raked by wagons, etc., when the car is being loaded or unloaded.

The fender consists of a 5 in. by 2½ in. angle held out from the side of the car by means of cast filler blocks; at the ends snub-nosed castings are used. When shut the front end of the door fits into an angle, the idea being to prevent it from bulging out in case freight should accidentally fall against it on the inside. It is securely fastened by a one link chain and hook in the rear which it is believed is sufficient to keep the rear edge of the door from bulging out. This door does not run on pulleys, but is supported at the bottom near each end by hard bearing points. It is claimed that in many instances after several months' service the pulleys which are commonly used for supporting car doors rust and stick. Further advantage in suspending the door on bearing points at the bottom is claimed, as when it is

suspended from the top by means of pulleys, very few bolts or rivets can be employed to carry the weight of the door itself.

### STAYBOLT CHUCK

The Christopher Murphy Company, Chicago, has recently placed on the market a square grip staybolt chuck as shown in

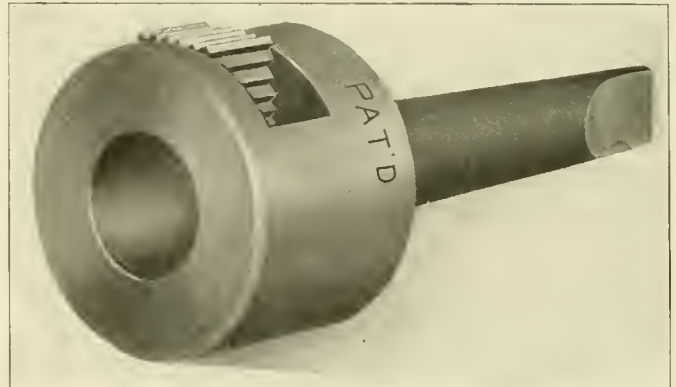

Square Grip Staybolt Chuck

the illustration. This chuck is used for screwing staybolts in the boiler and its chief advantage is that it is not necessary to put a

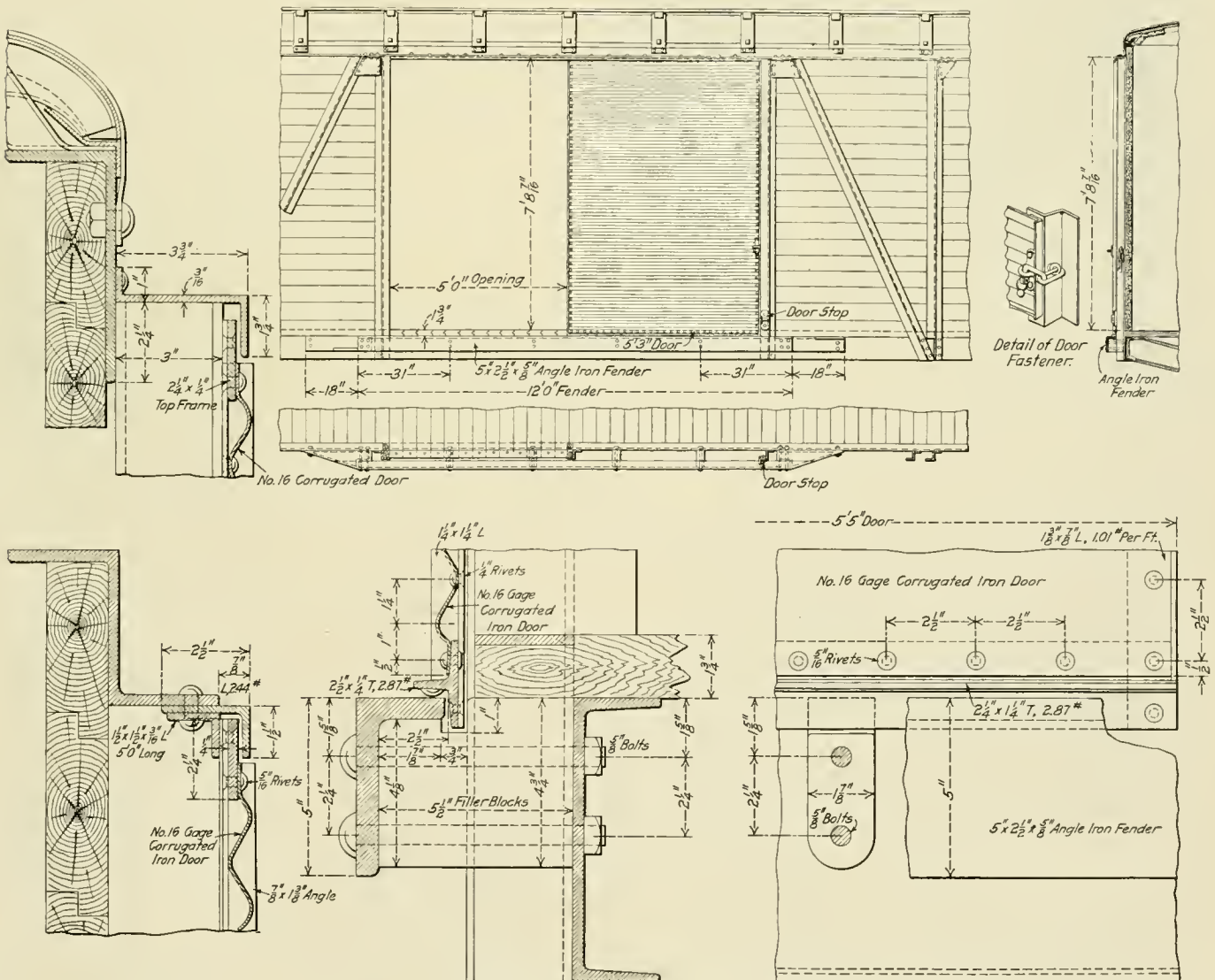

Corrugated Steel Box Car Door Equipped with a Fender at the Bottom to Prevent Raking by Wagons



square end on the staybolt for application. This chuck will grip the round iron by means of the dog inserted as shown in the engraving, and will turn either to the left or the right, gripping the iron harder the harder it is turned. By its use it will not be necessary to heat the staybolt in making the square for the head, and there will also be a considerable saving in metal as the staybolt need not be made as long. The dog is made of tool steel and is square, so that as one surface wears, another may be used, it being free to revolve on a pin in the chuck body, which is a drop forging. The chuck is provided with a No. 3 Morse taper and is made in sizes of  $\frac{3}{4}$  in. to  $1\frac{3}{4}$  in.

**MUDGE-PEERLESS VENTILATOR**

The new Mudge-Peerless ventilator, which is made and sold by Mudge & Company, Chicago, is being applied on a large order for equipment now being built by the Pullman Company,

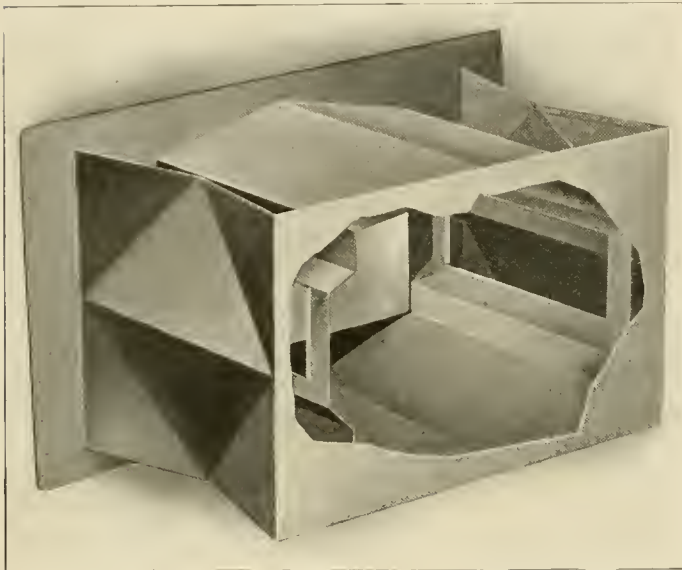

Fig. 1—Type 4 Mudge-Peerless Ventilator Showing Interior Arrangement

at Chicago. This ventilator, as shown in Fig. 1, is box-like in shape with the air ramming faces arranged transversely to the line of car travel. These faces are pressed in the form of a *I*'

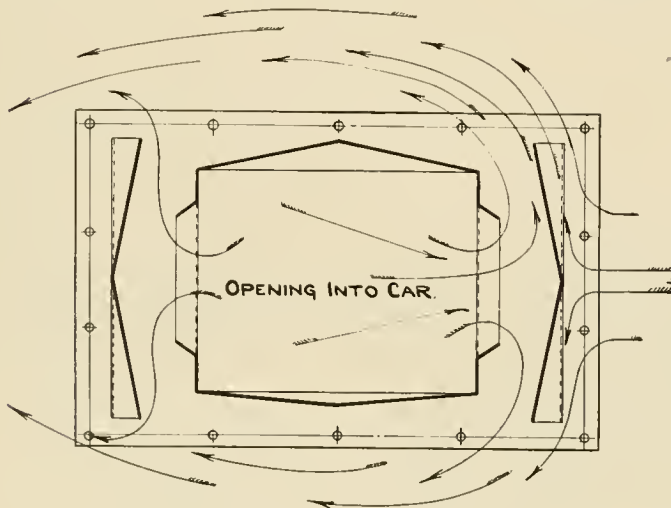

Fig. 2—Sectional View of the Mudge-Peerless Ventilator Showing the Action of the Air Currents

at each side of the center line and at right angles to the ventilator opening of the car, the *I*' shaped surfaces being inclined

toward the exhaust outlets from the interior. The purpose of this formation is to prevent the air displaced by the ventilator from escaping around the side of the monitor type roof or over the top of the arch type roof.

The sectional view, Fig. 2, shows the action of the outside air as it passes over and under the exhaust openings, drawing the vitiated air from the car body through the ventilator opening. The greater the velocity of the air passing over these openings the greater will be the efficiency of the venti-

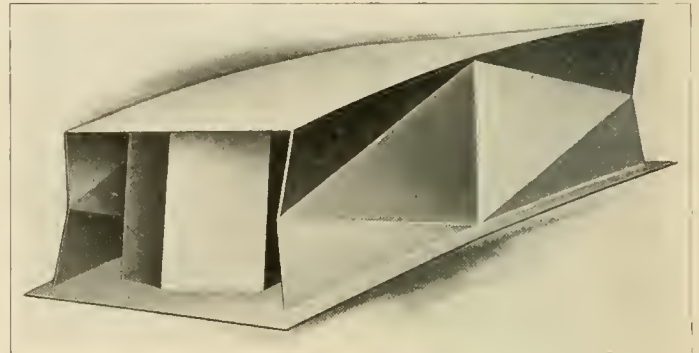

Fig. 3—Ventilator for Arch Type Roof

lator. On the arch or turtle back car roofs the operating principle is identical except that the vacuum pockets are formed at the exhaust opening on the sides of the ventilators. An illustration of the ventilator for these types of roofs is shown in Fig. 3. The interior construction of this ventilator is hexagonal in form, the rear end fitting tightly over the opening into the car while the front is solidly joined to the outside wall. Protecting exhaust outlets are provided for practically the full length on both sides directly behind the air ramming faces.

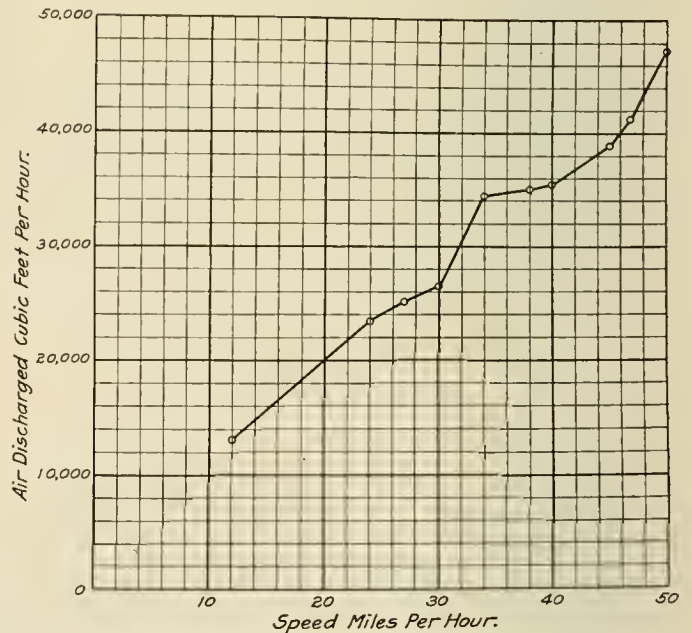

Fig. 4—Exhaust-Speed Curve of Mudge-Peerless Ventilator

The angular baffle plates which virtually form the roof prevent rain or other elements from dropping down into the interior, and the outside ventilator face prevents down drafts being caused by side winds. Two small openings are provided in the bottom plate to discharge the condensation in case the atmosphere contains a great deal of moisture.

The efficiency of this ventilator and the ratio of the exhaust to train speed is shown in Fig. 4. This chart was compiled from anemometer readings taken on a wooden frame car with

all doors and windows closed during the test. Tests have also shown a strong exhaust action with the trains standing, if side

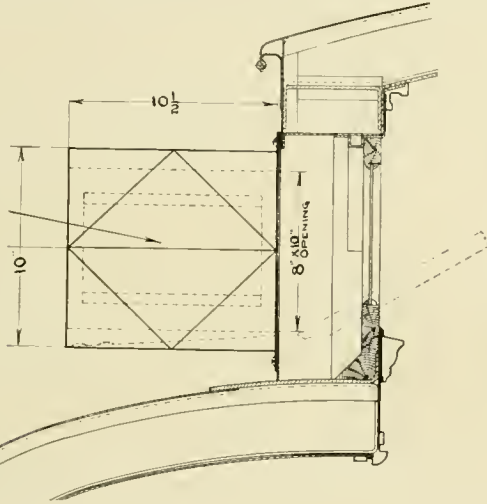

Fig. 5—Application of Ventilator to Monitor or Clerestory Roof

winds are blowing from any angle. With a side wind blowing at a velocity of 4.25 m. p. h., an exhaust of 3,600 cu. ft. per

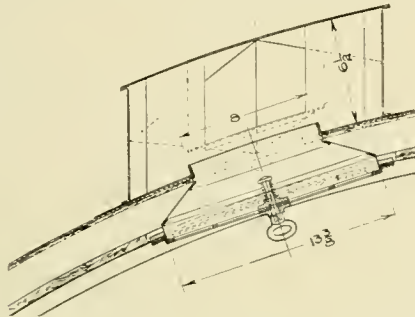

Fig. 6—Application of Ventilator to Arch Roof

hour was obtained and at 7.5 m. p. h., 6,480 cu. ft. was obtained, the same car being used as mentioned in the running test.

The application of the monitor roof type ventilator is shown

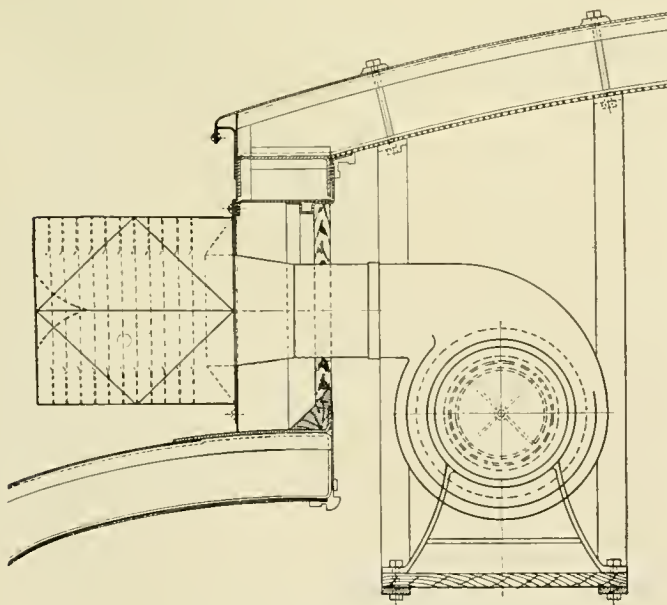

Fig. 7—Combined Ventilator and Blower

in Fig. 5. It is made in one standard size and design requiring no soldering or fitting, as it is simply bolted or screwed to

the screen board. The standard deck sash behind the ventilator is then used for regulating the flow of air. The arch or elliptical roof type ventilator is shown in Fig. 6. It is applied in a different manner, since it is made to conform to the curvature of the roof. A 1 1/2 in. flange is provided for soldering it to the roof sheets to insure water tight connections. Ventilation with this type of ventilator is controlled individually by operating registers applied to the headlining beneath each ventilator.

Fig. 7 shows the application of this ventilator in conjunction with an electric blower making a complete combination for the ventilation of dining cars which require the expulsion of fumes, smoke and kitchen odors while the car is standing. This type is provided with louvres as shown by the dotted lines. Its outside application to the screen board in the monitor roof car is the same as the type previously described. Simplicity has been carefully sought in both the construction and application of these various types of ventilators with a view to reducing the first cost and cost of maintenance.

### SOFT METAL GRINDERS FOR SUPER-HEATER UNIT CONNECTIONS

A soft metal process of grinding ball joints has been developed by the Locomotive Superheater Company, 30 Church street, New York, for use in maintaining the joints between

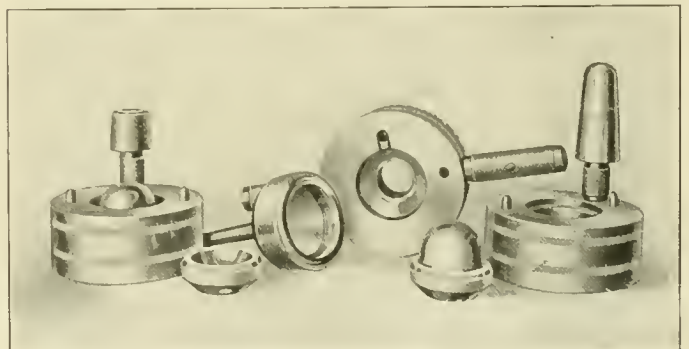

Mould Complete with Chuck and Grinders

superheater elements and the header. The importance of maintaining the correct radius of the two parts of these joints is apparent. It has been found that grinders made of cast iron or steel are frequently continued in use after they have

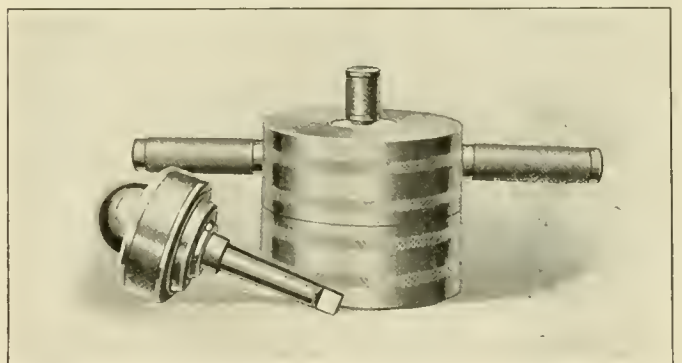

Mould Assembled for Casting the Grinding Sphere and Chuck with Grinder in Position

lost the proper shape because of the lack of tools or facilities for truing them up. The development of the soft metal process has provided a means by which grinders can be quickly and cheaply renewed as often as is necessary, without the service of skilled labor or machine tools.

Grinding cups for the ball ends of the units and grinding



spheres for the seats in the header are made of lead or hard babbitt metal by casting in moulds which insure uniformity and correctness of the contour. A mould consists of three parts, a base in which the cup grinder is cast, a base in which the spherical grinder is cast and the top part of the mould which is used with either base. A chuck is provided which will hold either the cup or the spherical grinder and which has a shank suitable for use in an air motor or hand brace. When the grinders lose their contour they may be melted and re-moulded with no waste of material. The chucks and the mould are furnished by the Locomotive Superheater Company.

### GRAVITY FIRE DOOR

A foot operated locomotive fire door, the two halves of which are so arranged as to counterbalance each other, thus making unnecessary the employment of a power cylinder, has been developed and patented by P. C. Withrow, mechanical engineer of the Denver & Rio Grande.

As shown in the engraving the door is in two sections, the upper part being pivoted at the left and the lower part at the right. It is opened by means of a foot lever located at the left and 20 in. out from the back head. This lever operates the door opening cam, which has a specially formed shoe at its upper end bearing against the under side of the upper door at *A*.

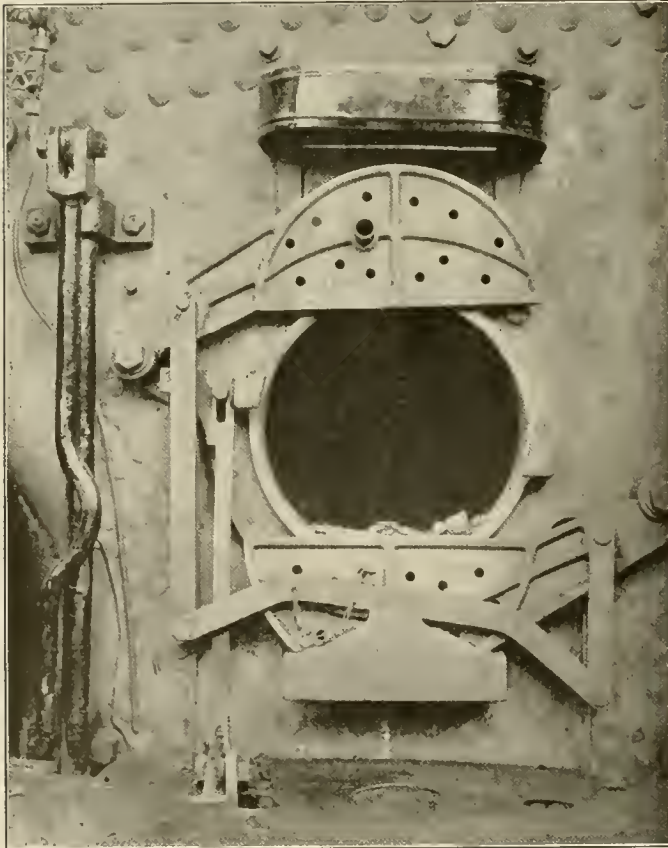

Gravity Fire Door Locked in Open Position

As pressure on the foot lever opens the door the point of contact between the cam and the door shifts from *A* to *E*. This gives a comparatively large leverage by means of which to start the door without unnecessary effort, and the decreasing leverage as the movement progresses keeps the travel of the foot pedal within reasonable limits.

The upper and lower sections of the door are connected by means of rods *B* and *D* and equalizer *C*. The pin *F* which connects rod *B* to the upper door is located above the hinge pin *G*, thus causing it to swing in closer to the vertical line through

the hinge pin as the door is opened. The leverage of the upper door, the weight of which causes the closing movement, is thus increased. It will be noted that the pin which secures rod *D* to the lower section of the door is located at a point much nearer the horizontal center line through the hinge pin than is pin *F* in the upper door. The increase in leverage of the lower door in the open position is therefore less than that of the upper door. A further increase in leverage of the upper section is effected by the rolling contact between equalizer *C* and the door

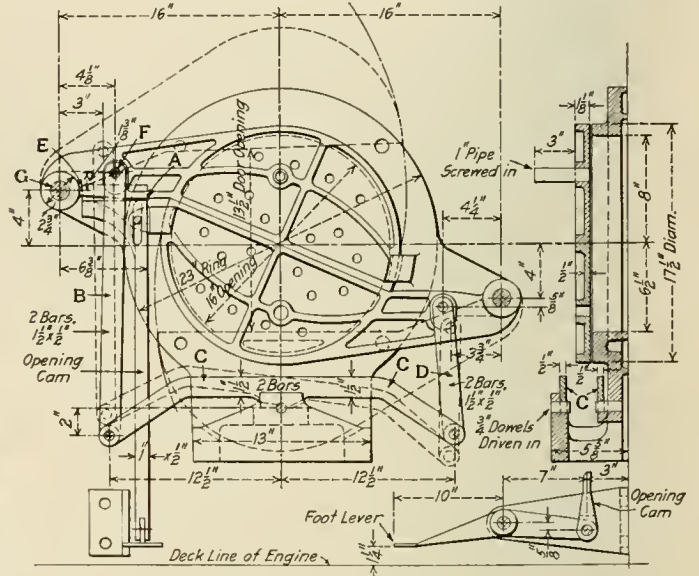

Simple Gravity Fire Door

frame at the right of the equalizer fulcrum pin. This causes the fulcrum to gradually travel to the right as the door is opened. The upper door thus has sufficient overbalance to insure prompt closing on releasing the pressure from the foot lever. As the closing movement proceeds the various points return to a normal position, thus destroying the overbalance, and the closing is completed without slamming. The foot lever bracket may be fastened either to the back head or the deck as is most convenient.

This device has been in use experimentally on the Denver & Rio Grande for about two years, where it has been meeting with considerable favor. It is claimed that prompt opening of the door is effected without extraordinary effort; sufficient force is brought to bear upon the pedal by the natural swinging of the weight to the left foot as the fireman swings the shovel toward the fire door.

### HAND SAW FOR CUTTING METAL

A metal cutting saw having a blade of the form usual for wood hand saws has been brought out by Henry Disston & Sons, Philadelphia, Pa. This saw has a special high temper suitable for metal cutting and is hollow ground for clearance. For cutting iron and steel it is regularly made with 12 points to the inch; for copper and brass with 10 points.

To get best results from a hand saw of the usual form, it is necessary to use both hands, one to push the saw and the other to guide it. The depth of cut is also limited to the inside depth of the frame. With the wide blade saw it is possible to cut to any depth. As with the wood hand saw, it is only necessary to use one hand in operating, which is advantageous under certain conditions.

PANAMA CANAL TRANSFERRED.—A railway paper published in India states that the following recently appeared in an Indian examination paper. "The Panama Canal is being cut from Delhi to Bombay in order to facilitate the speedy passage home of persons going on short leave from the new capital of India."

# NEWS DEPARTMENT

In connection with the buy-a-bale-of-cotton movement which has been discussed in the newspapers, the Nashville, Chattanooga & St. Louis has announced that it will buy 125 bales of cotton at 10 cents a pound.

On September 1 the Illinois Central acquired from the Central Fruit Despatch, a subsidiary company, all its refrigerator cars and such cars not already lettered "I. C. R. R." will be relettered, to be operated hereafter by the railroad company direct.

The railroad companies have formally accepted the city ordinance governing the project for a new \$65,000,000 union station and yards in Chicago to be used by the Pennsylvania, the Burlington and other roads, and to be completed within five years. In return for closing certain streets and alleys the city will receive \$825,805 from the Union Depot Company.

The diary of a certain general superintendent shows that in one year he spent 101 days conferring with railroad commissions, committees of organized employees, city and town officers and officers of the courts; he was traveling over the road 155 days and spent 109 days at headquarters transacting business connected with the administration of the railroad.

On Tuesday, September 15, the Henry M. Flagler, the car-ferry which was built for the Florida East Coast for service between Key West and Cuba, was launched at the Cramp ship yards at Philadelphia. The ferry is built to accommodate 30 freight cars. It is 351 ft. long with 57-ft. beam. Its speed when loaded with 2,300 tons will be, it is estimated, about 12 knots.

The creosoting plant of the Missouri, Kansas & Texas at West Denison, Tex., has suspended operations because of a shortage of creosote oil. Large quantities of timber and ties are on hand ready to be treated, but the company's sources of supply have been Germany and England, and both of these are now cut off. The Pennsylvania Railroad has on hand a supply of creosote sufficient for the needs of its timber preserving plant for a considerable time to come.

The safety department of the Delaware, Lackawanna & Western, in Safety First Bulletin No. 8, gives the number of deaths and injuries to employees during the first half of each year since 1910—1911, 1912, 1913 and 1914—showing a decrease each year. The number of killed was reduced from 34 in 1911 to 7 in 1914, and the number of injuries from 137 to 99. The bulletin gives the causes of the deaths of the seven men in 1914, and contains a large number of suggestions for improving the safety record; also a long list of commendable actions of employees shown on discipline bulletins for four months of this year.

Figures recently compiled show that the number of stockholders of the New York, New Haven & Hartford is rapidly increasing under the management of Chairman Elliott. While the average increase from 1901 to 1912 was 1,194, the increase from 1912 to 1913 was 1,162, and from June 30, 1913, to August 31, 1914, was 2,305. The totals, with the number of women stockholders, about 43 per cent, are as follows:

	Total	Women
June 30, 1901.....	9,667	.....
June 30, 1906.....	12,627	.....
June 30, 1912.....	22,806	9,710
June 30, 1913.....	23,968	10,474
August 31, 1914.....	26,373	11,184

The New York, New Haven & Hartford reports that its plan for reducing the number of forest fires on Cape Cod by clearing wide strips along its right of way has met with marked success. This year from May to August inclusive there were only

eleven fires attributable to sparks from locomotives and the territory burned over amounted to not more than 6¼ acres. In the same period last year there were 150 forest fires which burned over an area estimated at about 2,000 acres. Through all the wooded parts of Barnstable county a strip varying in width from 60 ft. to 130 ft. has been cleared on either side of the railroad's right of way. Pine trees have been left standing in these strips, as their leaves act as a screen. The areas cleared will be kept in that condition by the section gangs.

Thomas Cooper, land commissioner and assistant to the president of the Northern Pacific, has issued a statement announcing that during the last fiscal year the road has sold 800,000 acres of land, chiefly in Washington and Montana. A large area of eastern Washington land, suitable now only for grazing, brought 75 cents to \$2.50 per acre. The company estimates the total land grant from Lake Superior to Puget Sound at 40,000,000 acres. The total sales to June 30, last, approximated 30,000,000 acres. Of the 10,000,000 acres remaining about half is still unsurveyed and unpatented. These figures were made public to refute many incorrect statements made during political campaigns, in which it has been alleged that the railway delayed federal surveying of its land to escape taxation. Mr. Cooper says that for 10 years the company has urged the government to hasten surveys, thereby enabling the company to sell its land and push development of its tributary country. The company has applied for a survey of practically all of the 5,000,000 acres still unsurveyed.

At the regular monthly meeting of the board of directors of the New York, New Haven & Hartford, held in New York on September 17, the officers were authorized by the board to purchase power from the New York Edison Company. This purchased power, together with that now obtained from the power plant of the New York Central and that of the New Haven at Cos Cob, will enable the road to increase the number of trains operated electrically between New York and New Haven from 37 per cent to 70 per cent of the total. In order to have 100 per cent of electrical operation it will be necessary to purchase additional electrical equipment and additional power for the eastern section of the electric zone between New York and New Haven. At the present time all of the important passenger trains and a number of the important freight trains running between the two cities are hauled by electric locomotives.

## RESUMPTION OF TRAFFIC TO MEXICO

Announcement has been made by officers of the Texas & Pacific and International & Great Northern that affairs in Mexico have reached a state where traffic with the United States is being resumed. The International & Great Northern, in connection with the Texas & Pacific and St. Louis, Iron Mountain & Southern, previous to the trouble in Mexico ran through trains via Laredo, Tex., to the City of Mexico in connection with the National Railways of Mexico. The war caused the suspension of this traffic. Recently arrangements have been made with the Constitutionalists for an interchange of traffic between the Gould lines and the Mexican railways at Laredo. All freight in both directions is transferred in the International & Great Northern yards at Laredo. No through rates are in effect and through bills of lading cannot be issued. Through train service over the railroad between Laredo and the City of Mexico was resumed on August 26, the track which was destroyed in connection with the operations of the war having been made passable. Numerous branch roads are being repaired rapidly.



**THE SAN FRANCISCO FAIR**

An army of men is now busily engaged in completing the landscaping of the Panama-Pacific International Exposition. The era of construction on the exhibit palaces has passed and the installation of exhibits has begun. Within a few weeks thousands of exhibitors, with their army of attendants, will be installing their displays. Altogether more than 70,000 tons of exhibits will be brought to the grounds, the freight charges on which, it is estimated, will entail an outlay of more than \$4,000,000. The traffic department of the exposition estimates that more than 1,000,000 people will cross the Rocky mountains to the Pacific coast next year.

**FOREIGN ELECTRIFICATION PROJECTS**

Among the many large and important engineering improvements which will undoubtedly be seriously delayed because of the war are the electrifications of steam railroads in Germany, France and other countries. The greatest delay may be expected in Germany, partly because of the diversion of government funds to war purposes and partly because of the fact that the latest electrification, that in Silesia, is close to the Russian border. In any event, the railroads will be so overcrowded because of troop and supply transportation that no such interruptions as are incident to a change from steam to electricity would be permitted. It is doubtful also whether the state railway electrification will be furthered in a time of such financial stress.

**NEW YORK STATE BARGE CANAL**

The engineers of the western division of the New York Barge Canal are preparing plans for the construction of sections of the canal under six railroad crossings east of Rochester and six west of that city. The work on this part of the canal has been postponed because of litigation as to the right of the state to take the land occupied by the railroads. A recent court decision affirms the right of the state to exercise eminent domain in these cases; but the state must build and maintain the bridges necessary for the crossing of the railroads. State Engineer Benschel reports that the terminal facilities for the canal in Rochester, Syracuse, Oswego and other cities will be ready by the time the canal is finished. About 70 per cent of the work on the canal between Buffalo and Albany has been turned over by the contractors to the state.

**BROTHERHOODS ENJOINED**

Five conductors of the St. Louis Southwestern went into court at St. Louis recently and secured a temporary injunction restraining five vice-presidents of railwaymen's unions from bringing about a strike following an ultimatum delivered to the management of the road. The trouble arose when the management refused to reinstate a conductor who had been accused of drunkenness. The five conductors said a majority of the engineers employed by the road had voted against a strike and that the engineers' brotherhood had withdrawn from the federation when it appeared that the strike order would be issued. The defendants must show cause why the injunction should not be made permanent. Soon after the

injunction was granted the railroad company asked the Federal Board of Mediation to use its offices to avert the strike. President Britton said that this action was taken in order to leave no stone unturned toward preventing the strike.

**GOVERNMENT FREIGHT CAR STANDARDS IN CANADA**

The Board of Railway Commissioners for Canada, modifying its general order of February 17, 1913, respecting safety appliances on trains, has granted an extension of time until July 1, 1916, within which to make the following changes:

To change the location of brakes on all cars; to comply with the standard specifications prescribed in the regulations in respect of all brakes; to change cars having less than 10 in. end ladder clearance within 30 in. of the side of car; to comply with the standard prescribed in the regulations in respect to hand holds, running boards, ladders, sill steps, and brake staffs, except that when a car is shopped for work amounting practically to rebuilding the body of the car, it must then be equipped according to the prescribed standard regulations.

Railway companies are not to be required to make changes to secure additional end ladder clearance on cars that have 10 or more inches end ladder clearance within 30 inches of side of car, or to make the changes in end ladders, side ladders, hand grips and steps which have been made in accordance with the provisions of the general order above referred to, or to comply with the board's regulations aforesaid, until the car is shopped for work amounting to practically rebuilding body of car.

And it is further ordered that railway companies shall not be required to change the location of hand holds (except end band holds under the end sills), ladders, sill steps, brake wheels, and brake staffs on freight train cars where the appliances are within 3 in. of the required location, except that when cars undergo regular repairs they must then be made to comply with the prescribed standards.

**AIR BRAKE STORY PRIZES**

The judges in the Westinghouse Air Brake Company prize story contest have made their decision, awarding the first prize of \$1,000 to James Cain, engineer of the Wabash Railroad at Peru, Ind. The second prize of \$500 was awarded to H. C. Woodbridge, general manager's special representative, Buffalo, Rochester & Pittsburgh, Rochester, N. Y.; the third prize of \$200 to Alexander M. Stewart, engineer, Illinois Central, McComb, Miss.; the fourth prize of \$150 to D. Oxenford, road foreman of engines, Lehigh Valley, New York City; the fifth prize of \$100 to Carl H. Fuller, chief engineer, Macon Railway & Light Company, Macon, Ga., and the sixth prize of \$50 to Millard F. Cox, assistant superintendent machinery, Louisville & Nashville, Louisville, Ky. Considerably over 300 contributions were entered in this contest, the judges being W. E. Symons, consulting mechanical engineer, Chicago; Willard Smith, editor of the Railway Review, Chicago, and Roy V. Wright, managing editor of the Railway Age Gazette, New York City.

**RAILROAD CLUB MEETINGS**

Club	Next Meeting	Title of Paper	Author	Secretary	Address
Canadian .....	Oct. 13	Wooden Frame Cars in Freight Trains....	G. Smart .....	James Powell....	Room 13, Windsor Hotel, Montreal.
Central .....	Nov. 13	Steel Equipment .....	H. M. Butts....	H. D. Vought....	95 Liberty St., New York City.
New England....	Oct. 13	Cape Cod Canal.....	Capt. J. W. Miller..	Wm. Cade, Jr....	683 Atlantic Ave., Boston, Mass.
New York.....	Oct. 16	.....	.....	H. D. Vought....	95 Liberty St., New York City.
Pittsburgh .....	Oct. 23	Annual Meeting .....	.....	J. B. Anderson..	207 Penn. Station, Pittsburgh, Pa.
Richmond .....	Oct. 12	.....	.....	F. O. Robinson..	C. & O. Ry., Richmond, Va.
St. Louis.....	Oct. 9	.....	.....	B. W. Frauenthal.	Union Station, St. Louis, Mo.
Southern & S'w'rn	Nov. 19	.....	.....	A. J. Merrill....	218 Grant Bldg., Atlanta, Ga.
Western .....	Oct. 20	.....	.....	Jos. W. Taylor....	1112 Karpen Bldg., Chicago, Ill.

## CERTAIN OXY-ACETYLENE APPARATUS CONDEMNED

At a recent meeting in Chicago of the International Acetylene Association resolutions were adopted condemning apparatus for oxy-acetylene work which provides for the generation and self-compression of acetylene or oxygen at a pressure greater than 15 lb. per sq. in. The resolutions were presented by a committee of which Professor Pond, University of Pennsylvania, was chairman, following the report of the committee on oxy-acetylene of which Augustine Davis, president Davis-Bournonville Company, was chairman. The resolutions referring to the generation and compression of acetylene gas are in accord with the regulations of the National Board of Fire Underwriters. Owing to the numerous accidents resulting from the simultaneous generation and self-compression of oxygen by heating chlorates, the association condemns this practice and recommends that chlorates should not be used for the generation of oxygen, except in connection with an efficient washing system and gas holder operating under inconsiderable pressure, and that compression be effected only by means of compressors especially constructed for oxygen.

## MEETINGS AND CONVENTIONS

*Railway Storekeepers' Association.*—The twelfth annual convention of the Railway Storekeepers' Association will be held at the Hotel Sherman, Chicago, May 17-19, 1915.

*Industrial Welfare and Efficiency Conference.*—The commissioner of Labor and Industry of the state of Pennsylvania, Honorable John Price Jackson, has called the second Pennsylvania Industrial Welfare and Efficiency Conference to meet in Harrisburg, November 16-20, inclusive. The commissioner is determined that each of these conventions will mark a definite step in advance and each year will see his efforts more representative and more widely extended. It is the desire of the commissioner that the exhibit this year be kept along the lines that bear particularly on the interests represented by his department, and the Engineers' Society of Pennsylvania has undertaken to manage this part of the convention. Manufacturers and distributors of products to improve the safety, sanitation, welfare and efficiency of the factory, office and home are asked to exhibit.

*The following list gives names of secretaries, dates of next or regular meetings, and places of meeting of mechanical associations.*

- AIR BRAKE ASSOCIATION.**—F. M. Nellis, 53 State St., Boston, Mass. Convention, May 5-7, 1915, Hotel Sherman, Chicago.
- AMERICAN RAILWAY MASTER MECHANICS' ASSOC.**—J. W. Taylor, Karpen building, Chicago.
- AMERICAN RAILWAY TOOL FOREMEN'S ASSOCIATION.**—Owen D. Kinsey, Illinois Central, Chicago. Convention, July, 1915, Chicago.
- AMERICAN SOCIETY FOR TESTING MATERIALS.**—Prof. E. Marburg, University of Pennsylvania, Philadelphia, Pa.
- AMERICAN SOCIETY OF MECHANICAL ENGINEERS.**—Calvin W. Rice, 29 W. Thirty-ninth St., New York. Convention, December 1-4, 1914, New York.
- CAR FOREMEN'S ASSOCIATION OF CHICAGO.**—Aaron Kline, 841 North Fiftyeth Court, Chicago; 2d Monday in month, except July and August, Lytton building, Chicago.
- CHIEF INTERCHANGE CAR INSPECTORS' AND CAR FOREMEN'S ASSOCIATION.**—S. Skidmore, 946 Richmond street, Cincinnati, Ohio.
- INTERNATIONAL RAILWAY FUEL ASSOCIATION.**—C. G. Hall, 922 McCormick building, Chicago. Convention, May 17-20, 1915, Chicago.
- INTERNATIONAL RAILWAY GENERAL FOREMEN'S ASSOCIATION.**—William Hall, 914 W. Broadway, Winona, Minn. Convention, July, 1915.
- INTERNATIONAL RAILROAD MASTER BLACKSMITHS' ASSOCIATION.**—A. L. Woodworth, Lima, Ohio.
- MASTER BOILER MAKERS' ASSOCIATION.**—Harry D. Vought, 95 Liberty St., New York.
- MASTER CAR BUILDERS' ASSOCIATION.**—J. W. Taylor, Karpen building, Chicago.
- MASTER CAR AND LOCOMOTIVE PAINTERS' ASSOC. OF U. S. AND CANADA.**—A. P. Dane, B. & M., Reading, Mass.
- NIAGARA FRONTIER CAR MEN'S ASSOCIATION.**—E. Frankenberg, 623 Brisbane building, Buffalo, N. Y. Meetings monthly.
- RAILWAY STOREKEEPERS' ASSOCIATION.**—J. P. Murphy, Box C, Collinwood, Ohio. Convention, May 17-19, 1915, Hotel Sherman, Chicago.
- TRAVELING ENGINEERS' ASSOCIATION.**—W. O. Thompson, N. Y. C. & H. R., East Buffalo, N. Y.

## PERSONALS

*It is our desire to make these columns cover as completely as possible all the changes that take place in the mechanical departments of the railways of this country, and we shall greatly appreciate any assistance that our readers may give us in helping to bring this about.*

### GENERAL

E. S. FITZSIMMONS, mechanical superintendent of the Ohio division of the Erie at Cleveland, Ohio, has been appointed mechanical superintendent of the Erie division with headquarters at New York.

CHARLES JAMES, master mechanic of the Erie at Jersey City, N. J., has been appointed mechanical superintendent of the Ohio division at Cleveland, Ohio, succeeding E. S. Fitzsimmons.

W. J. MILLER, master mechanic of the St. Louis Southwestern of Texas at Tyler, Tex., has been appointed superintendent of motive power of the St. Louis Southwestern, with office at Pine Bluff, Ark., succeeding T. E. Adams, deceased.

A. G. TRUMBULL, mechanical superintendent of the Erie at New York, has been appointed assistant to the general mechanical superintendent with headquarters at New York.

DAVID VAN ALSTYNE has been appointed assistant to the vice-president of operation of the New York, New Haven & Hartford, with headquarters at New York. Mr. Van Alstyne will have charge of the test and store departments and the handling of scrap; he will also have supervisory authority over the mechanical department in regard to organization, shop practice, approval of design, standards and requisitions.

### MASTER MECHANICS AND ROAD FOREMEN OF ENGINES

R. A. BILLINGHAM has been appointed master mechanic of the Tennessee Central, with office at Nashville, Tenn., succeeding J. J. Clark, resigned.

J. M. KILFOYLE has been appointed master mechanic of the St. Louis Southwestern of Texas at Tyler, Tex., succeeding W. J. Miller, promoted.

CHARLES MANLEY has been appointed master mechanic of the Missouri & North Arkansas, with office at Harrison, Ark., succeeding J. P. Dolan, resigned.

F. H. MURRAY, master mechanic of the Erie at Port Jervis, N. Y., has been transferred to Jersey City, N. J., succeeding Charles James.

GEORGE SEARLE, formerly general roundhouse foreman of the Atchison, Topeka & Santa Fe at San Bernardino, Cal., has been appointed master mechanic of the Los Angeles division of the San Pedro, Los Angeles & Salt Lake at Las Vegas, Nev., succeeding W. A. Rogers, resigned.

W. H. SNYDER, general foreman of the Erie at Stroudsburg, Pa., has been appointed master mechanic at that point, succeeding T. S. Davey, promoted.

GEORGE THIBAUT, general foreman of the Erie at Susquehanna, Pa., has been appointed master mechanic at Port Jervis, N. Y., succeeding F. H. Murray.

WILLIAM V. WICKS has been appointed road foreman of engines of the Northern Pacific, at Jamestown, N. D.

### CAR DEPARTMENT

T. S. DAVEY, master mechanic of the Erie at Stroudsburg, Pa., has been appointed shop superintendent of the car shops at Buffalo, N. Y. Mr. Davey started railroad work with the



Delaware, Lackawanna & Western at Scranton, Pa., in 1893 where he served his apprenticeship as machinist. In 1898 he entered the service of the Erie at Stroudsburg, Pa., as a machinist. He was later appointed gang foreman and general foreman, holding the latter position for eight years. About three years ago he was appointed master mechanic at Stroudsburg, the position he now leaves to become shop superintendent at Buffalo, as above noted.

JOHN A. BIEBER, coach yard foreman of the Atchison, Topeka & Santa Fe at Richmond, Cal., has been appointed repair track foreman at that point.

A. J. CHUBB has resigned the position of chief inspector, car department of the Pere Marquette, and that position has been abolished.

B. FLAHERTY has been appointed general car foreman of the Chicago, Rock Island & Pacific at Manly, Ia., succeeding J. E. Giesler.

FRANK L. FOX has been appointed general foreman, car department, of the Pere Marquette, with headquarters at Detroit, Mich. He will have jurisdiction over all matters pertaining to the car department.

W. H. HADLEY, repair track foreman of the Atchison, Topeka & Santa Fe at Richmond, Cal., has been appointed car foreman at Winslow, Ariz.

W. D. LEFEBERIES has been appointed car foreman of the Chicago, Rock Island & Pacific at Peoria, Ill., succeeding S. E. Nell.

S. E. NELL has been appointed car foreman of the Chicago, Rock Island & Pacific at Rock Island, Ill., succeeding B. Flaherty.

PETER OLSON has been appointed temporary car foreman of the Chicago, Rock Island & Pacific at Inver Grove, Minn.

WILLIAM SCHMALZRIED, foreman of car shops of the Texas & Pacific at Ft. Worth, Tex., has been appointed master car builder, with office at Marshall, Tex., succeeding W. D. Minton, resigned.

C. A. ZWEIBEL has been appointed supervisor of car repairs of the Atlantic Coast Line, with office at Wilmington, N. C., succeeding E. A. Sweeley, resigned, to go to another company.

#### SHOP AND ENGINE HOUSE

A. ANDERSON has been appointed boiler foreman of the Chicago, Rock Island & Pacific at Manly, Iowa, succeeding C. Lynch.

E. E. CHRYSLER, master mechanic of the Chicago & Alton at Slater, Mo., has been appointed superintendent of shops of the Oregon Short Line, with headquarters at Pocatello, Idaho, succeeding D. J. Malone, deceased.

P. F. HARRIS has been appointed day roundhouse foreman of the Chicago, Rock Island & Pacific at Manly, Iowa, succeeding G. T. Schroeder.

L. L. HOFFMAN has been appointed night roundhouse foreman of the Chicago, Rock Island & Pacific at Manly, Iowa, succeeding P. F. Harris.

H. KRABBENHOFT has been appointed night foreman of the Chicago, Rock Island & Pacific at Rock Island, Ill., succeeding F. Meredith.

WILLIAM SCHUMAN has been appointed general foreman of shops of the Chicago, Indianapolis & Louisville at Lafayette, Ind., succeeding George Crumbo, resigned.

#### PURCHASING AND STOREKEEPING

E. O. GRIFFIN, general fuel and supply agent of the International & Great Northern, has been appointed purchasing agent for the receivers, with headquarters at Houston, Tex., and will report to Thornwell Fay, assistant to receivers.

H. E. HALLENBECK has been appointed storekeeper of the Albuquerque division of the Atchison, Topeka & Santa Fe at Belen, N. M., succeeding N. R. Snowden.

J. V. MAYHALL has been appointed assistant storekeeper of the Baltimore & Ohio at Parkersburg, W. Va., succeeding W. D. Stone.

H. E. RAY has been appointed general storekeeper of the Atchison, Topeka & Santa Fe at Topeka, Kan.

J. H. SANFORD, purchasing agent of the New York, New Haven & Hartford at New Haven, Conn., has been appointed purchasing agent of the Connecticut Company, and will also buy for the Rhode Island Company, the Housatonic Power Company, the Berkshire Street Railway, the New York & Stamford Railway, the Westchester Street Railroad and the Westport Water Company. Mr. Sanford will have his headquarters at New Haven.

G. A. SECOR, storekeeper of the Minneapolis & St. Louis at Minneapolis, Minn., has been appointed general storekeeper of the Chicago & Alton at Bloomington, Ill., succeeding Daniel Downing, resigned.

N. R. SNOWDEN has been appointed storekeeper of the New Mexico division of the Atchison, Topeka & Santa Fe north of Las Vegas, with headquarters at Raton, N. M., succeeding A. B. Wachter.

K. R. STEWART has been appointed storekeeper of the Atchison, Topeka & Santa Fe at San Bernardino, Cal., succeeding H. E. Ray.

A. B. WACHTER has been appointed storekeeper of the Albuquerque division of the Atchison, Topeka & Santa Fe at Albuquerque, N. M., succeeding K. R. Stewart.

C. M. WESTER has been appointed storekeeper of the Baltimore & Ohio, with office at Parkersburg, W. Va., succeeding D. L. Donaldson.

#### I. C. C. APPOINTMENTS

FRED M. BAUMGARDNER has been appointed senior inspector of motive power in the central district, division of valuation, Interstate Commerce Commission, with headquarters at Chicago. His experience has been with the mechanical department of the Union Pacific and the Illinois Central, having served as roundhouse foreman, general foreman and master mechanic on the latter road and having recently been made master mechanic at Clinton, Ill.

R. F. PETERS, mechanical engineer of the San Antonio & Aransas Pass at San Antonio, Tex., has been appointed senior mechanical engineer of the Western district, division of valuation, Interstate Commerce Commission, with headquarters at Kansas City, Mo.

M. E. WELLS, who is now engaged on the appraisal of the Pere Marquette for the Michigan Railroad Commission, has been appointed senior inspector of motive power, division of valuation, Interstate Commerce Commission, for the Southern district, with headquarters at Chattanooga, Tenn., effective on October 1.

#### OBITUARY

THOMAS E. ADAMS, superintendent of motive power of the St. Louis Southwestern, with headquarters at Pine Bluff, Ark., died at his home in that city on August 25 at the age of 63 years. Mr. Adams has been in railway service since August, 1865, when he began as a fireman on the Illinois Central. He was consecutively locomotive engineer on that road, the Illinois Midland, the St. Paul, Minneapolis & Manitoba and the Great Northern, from November, 1870, to February, 1893, when he was appointed division master mechanic on the Great Northern. Three years later he became superintendent of the Dakota di-

vision of that road, and from February, 1897, to April, 1901, he was master mechanic of the Fergus Falls division and master mechanic at Superior, Wis. He then went to the St. Louis Southwestern as general master mechanic, and in July, 1905, was promoted to superintendent of motive power.

FRANK W. CHAFFEE, general car inspector of the New York Central & Hudson River, with headquarters at Albany, N. Y., died on September 15. He was born on December 17, 1850, at



F. W. Chaffee

Springfield, Mass., and began railway work in 1868 as car repairer on the Connecticut River Railroad, now a part of the Boston & Maine. From September, 1870, to December, 1872, he was with the Wason Car Manufacturing Company, and then to June, 1881, was in the car building department of the Boston & Albany. He was then for three years in the service of the Baltimore & Ohio at Camden station, Baltimore, and on June 1, 1884, left that company to go to the New York Central & Hudson River as general foreman of the West Al-

bany, N. Y., shops. He remained in that position until March, 1895, when he was promoted to master car builder at the same shops, and since February 1, 1901, has been general car inspector of the same road.

DANIEL E. SULLIVAN, formerly master mechanic of the Union Pacific at Cheyenne, Wyo., died at Ogden, Utah, on August 20, aged 60 years. He was employed by the Union Pacific for 34 years, retiring July 1 last on account of illness.

## NEW SHOPS

**SOUTHERN RAILWAY.**—A contract has been given to P. J. White & Son, Richmond, Va., for the construction of shop buildings at Richmond, and a contract has been given to the J. T. Wilson Company, Richmond, for building a transformer house at South Richmond.

**SOUTHERN RAILWAY.**—A contract has been given to the Ragland-Baxter Morford Company, Nashville, Tenn., for the construction of shop buildings at Memphis, and a contract has been given to the R. F. Creson Company, Memphis, for putting up a pump house, also transformer house at Memphis.

**ILLINOIS CENTRAL.**—A contract has been awarded for the construction of a mechanical terminal at Jackson, Miss., to Geo. B. Swift & Company, Chicago. The improvement consists of structures as follows: A roundhouse having five 100-ft. stalls with walls of concrete and brick construction, and roof of wood, covered with composition roofing; an 85-ft. turntable electrically operated; a machine shop and boiler room 40 ft. by 75 ft. by 16 ft., high, with brick walls and a flat concrete roof covered with composition roofing; an oil house and storeroom 30 ft. by 60 ft. one story high, with a low wooden platform 40 ft. by 75 ft. at one end; a shelter and shop building 20 ft. by 140 ft. by 11 ft. high, of wooden construction, and sand bins, 9 ft. by 98 ft. by 9 ft. high, also of wooden construction; a 500-ton wooden coal chute which is being built by the Ogle Construction Company, Chicago.

## SUPPLY TRADE NOTES

Charles B. Yardley, Jr., formerly of Jenkins Bros., has been appointed manager of the railway department of the United States Metal Products Company, New York.

The C & C Electric & Manufacturing Company, Garwood, N. J., has removed its Detroit office, in charge of R. K. Slaymaker, from 144 Seyburn avenue to 1111 Chamber of Commerce building.

A. T. Gardiner, for many years connected with the Landis Tool Company, Waynesboro, Pa., has accepted a position with the Modern Tool Company, Erie, Pa. He will cover the same territory as when with the Landis Tool Company.

J. G. Coutant, formerly engineer of the plant of the Lima Locomotive Corporation, Lima, Ohio, has gone with the Railway Materials Company, Chicago, Ill., to specialize in the design of furnaces for burning powdered fuel and water gas, having done considerable experimenting in this work.

The Raymond Concrete Pile Company, New York, has been awarded a contract for the design and construction of concrete ore, coke and limestone bins, and ore and yard trestles, by the Pennsylvania Steel Company, Steelton, Pa. The work calls for several thousand concrete piles and a large yardage of concrete construction.

The Transportation Utilities Company, with general offices at 30 Church street, New York City, has opened a branch office at 1201 Virginia Railway & Power building, Richmond, Va. This office is in charge of Frank N. Grigg, and is devoted exclusively to the appliances manufactured by the Transportation Utilities Company.

The U. S. Metal & Manufacturing Company, New York, has been appointed resident purchasing agent in America for the following companies: Underground Electric Railways of London, Ltd., the London General Omnibus Company, Ltd., the Metropolitan District Railway, the London Electric Railway, the Central London Railway and the City & South London Railway.

The Gun-crete Company, Chicago, has acquired the interests of the Cement Gun Construction Company and has absorbed the construction department of the General Cement Gun Company. The combined business will be conducted under the name of the Cement Gun Construction Company, with office at Chicago. Carl Weber is president, John V. Schaefer, secretary and treasurer, and C. L. Dewey, construction manager.

W. J. Johnson, formerly of the Western Electric Company, has recently been appointed a member of the engineering department of the Stentor Electric Manufacturing Company, Inc., New York. Mr. Johnson, who has had an extended experience with the Bell Telephone Company of Pennsylvania, and the Chesapeake & Potomac Telephone Company of Baltimore, will look after the installation work which the company has on hand.

H. O. Fettinger has been appointed eastern railroad representative of the Ashton Valve Company, Boston, Mass., with headquarters at 128 Liberty street, New York, to succeed W. H. Foster, resigned to become associated with another company. Mr. Fettinger formerly served for a number of years in the motive power department of the Pennsylvania Railroad, and resigned from the position of chief air brake and steam heat inspector to engage in the supply business.

At a meeting of the board of directors of the American Locomotive Company, held September 16, S. L. Schoonmaker was elected chairman of the board, succeeding Pliny Fisk, resigned, and Andrew W. Mellon, president of the Mellon National Bank of Pittsburgh, was elected a director succeeding James McNaughton. Mr. McNaughton will continue as vice-president. Mr. Schoonmaker is a director of the General Electric Company and the American Telephone & Telegraph Company.



T. P. Gaylord, who has recently been elected acting vice-president of the Westinghouse Electric & Manufacturing Company, succeeding Henry D. Shute, was born at Shelby, Mich., and attended preparatory school at Allen Academy, Chicago. He subsequently attended the University of Michigan, and in 1895 received the degree of electrical engineer from the Armour Institute of Technology. Mr. Gaylord was engineer of underground construction during the World's Fair at Chicago, 1892-3. At the close of the fair he became assistant professor of electrical engineering in the Armour Institute, and retained that position until 1898, when he became associated with the Commonwealth Edison Company of Chicago as electrical engineer. In July, 1899, he entered the employ of the Westinghouse Electric & Manufacturing Company as a salesman, and followed this line of work until 1903, when he was appointed district manager at Chicago, which position he has held up to the present. Mr. Gaylord is a member of the American Institute of Electrical Engineers, the National Electric Light Association, and a number of other engineering societies.



T. P. Gaylord

Henry D. Shute has been elected treasurer of the Westinghouse Electric & Manufacturing Company. Mr. Shute was born at Somerville, Mass., and attended high school in Boston. He graduated from the Massachusetts Institute of Technology in 1892, and following his graduation spent a year in Germany at the School of Mines, Clausthal, and in Dresden. In 1893 he entered the works of the Westinghouse Electric Company at Pittsburgh as an apprentice, and spent his first two years in the testing department, following which he was engaged for a considerable time in erection and laboratory work, part of the time as assistant foreman. In 1897 he entered the engineering department. One year later he was transferred to the commercial department, and in 1901 was appointed head of the latter's alternating current division. Two years later he was made assistant to vice-president L. A. Osborne, and in that position was particularly active in the development of heavy electric traction and single-phase railway work. In 1910 Mr. Shute succeeded Walter McFarland as acting vice-president, which position he held until his election as treasurer. Mr. Shute is a member of the American Institute of Electrical Engineers, the National Electric Light Association, and the Engineers' Club of New York, and is also a director of the Pittsburgh Chamber of Commerce.



H. D. Shute

## CATALOGS

**OIL AND GAS BURNING APPLIANCES.**—Bulletin No. 5 of the Quigley Furnace & Foundry Company, Springfield, Mass., is devoted to the line of burners, oil pumps and other furnace appliances developed by this company. It contains eight pages and is well illustrated.

**AUTOMATIC TRAIN STOP.**—The Automatic Railroad Appliance Company, Inc., Rochester, N. Y., has issued an 18-page pamphlet descriptive of the Lawn-Ryan automatic train stop for steam and electric roads. Illustrations of the mechanism are shown, and the description explains the method of operation and installation.

**PNEUMATIC TOOLS.**—Circular V of the Independent Pneumatic Tool Company, Chicago, Ill., is a four-page pamphlet in which the drills and hammers manufactured by this company are illustrated and brief specifications given as to the capacity and service for which they are designed. The specifications are very compactly arranged in tabular form.

**PACIFIC TYPE LOCOMOTIVES.**—The Baldwin Locomotive Works, Philadelphia, Pa., recently issued record No. 79, which is devoted to Pacific type locomotives. A brief historical sketch of the development of this type of locomotive is followed by a number of illustrated descriptions of Pacific type locomotives recently built by the Baldwin Locomotive Works.

**CLEANING COMPOUND.**—Information sheet No. 260 of the Oakley Chemical Company, 22 Thames street, New York City, is a 12-page booklet devoted to the application of Oakite to the various car cleaning operations and as a substitute for lye in cleaning air pumps, journal boxes, eccentrics, etc., in the locomotive shop. Directions are given for the use of Oakite in a large number of cleaning operations.

**TUBE CLEANERS.**—A number of catalogs have been issued by the Roto Company, Hartford, Conn., containing descriptions of the various types of tube cleaners manufactured by this company. Among these may be noted catalog No. 41, dealing with boiler tube cleaners driven by air or steam; catalog No. 43, in which cutter heads for boiler tube cleaners are described, and catalog No. 44, descriptive of locomotive arch tube cleaners.

**SAND BLAST.**—A reprint of a paper entitled "The Sand Blast from the Users' Viewpoint," which was presented at a recent meeting of the Associated Foundry Foremen, of New York and vicinity, by H. D. Gates, sales manager of the sand blast department, De La Vergne Machine Company, New York, has recently been issued by that company in pamphlet form. It contains considerable information which should be of value to those contemplating the installation of sand blast equipment. Copies will be furnished upon request.

**INDUSTRIAL FURNACE EQUIPMENT.**—The W. S. Rockwell Company, 50 Church street, New York, recently issued a bulletin containing a comparative scale and conversion factors for Fahrenheit and Centigrade thermometers. This information is printed on a stiff card, 9¼ in. by 11¼ in., which is designed to be hung in the laboratory or furnace room, where heat treating operations are conducted. Below the conversion factors are tables showing the various color heats in both Centigrade and Fahrenheit, and suggested tempering heats for use on various tools.

**APPLIANCES FOR BURNING FUEL OIL.**—A catalog recently issued by Tate, Jones & Co., Inc., Pittsburgh, Pa., deals with the system of oil-burning appliances developed by this company. It is divided into two parts. Considerable space in part one is devoted to the actual result obtained with crude oil in furnace work, tending to show the superiority of fuel oil over coal. The remainder of this part contains well illustrated descriptions of the various types of burners manufactured by this company. Part two contains illustrations and descriptions of pumping systems for handling fuel oil.

# Railway Age Gazette

MECHANICAL EDITION  
INCLUDING THE  
AMERICAN ENGINEER

PUBLISHED ON THE FIRST THURSDAY OF EVERY MONTH BY THE  
SIMMONS-BOARDMAN PUBLISHING COMPANY,  
WOOLWORTH BUILDING, NEW YORK, N. Y.

CHICAGO: Transportation Bldg. CLEVELAND: Citizen's Bldg.  
LONDON: Queen Anne's Chambers, Westminster.

EDWARD A. SIMMONS, *President* L. B. SHERMAN, *Vice-President*  
HENRY LEE, *Secretary*  
The address of the company is the address of the officers.

ROY V. WRIGHT, *Editor*  
R. E. THAYER, *Associate Editor* A. C. LOUDON, *Associate Editor*  
C. B. PECK, *Associate Editor*

Subscriptions, including the eight daily editions of the *Railway Age Gazette* published in June in connection with the annual conventions of the Master Car Builders' and American Railway Master Mechanics' Associations, payable in advance and postage free:

United States, Canada and Mexico.....	\$2.00 a year
Foreign Countries (excepting daily editions)....	3.00 a year
Single Copy .....	20 cents

Entered at the Post Office at New York, N. Y., as mail matter of the second class.

WE GUARANTEE, that of this issue 3,950 copies were printed; that of these 3,950 copies 3,454 were mailed to regular paid subscribers, 150 were provided for counter and news companies' sales, 236 were mailed to advertisers, exchanges and correspondents, and 110 were provided for samples and office use; that the total copies printed this year to date were 47,050, an average of 4,276 copies a month.

Statement of the ownership, management, etc., of the *Railway Age Gazette*, *Mechanical Edition*, published monthly at New York, N. Y.:

Editor, ROY V. WRIGHT, Woolworth Bldg., New York, N. Y.  
Business Manager, None.  
Publisher, SIMMONS-BOARDMAN PUBLISHING CO., Woolworth Bldg., New York, N. Y.

### STOCKHOLDERS:

EDWARD A. SIMMONS, New York. ROY V. WRIGHT, New York.  
LUCIUS B. SHERMAN, Chicago, Ill. ELMER T. HOWSON, Chicago, Ill.  
HENRY LEE, New York. A. C. BOARDMAN, Riverdale, N. Y.  
I. B. RINES, New York. F. BOARDMAN, Riverdale, N. Y.  
SAMUEL O. DUNN, Chicago, Ill. B. BOARDMAN, New York.  
RAY MORRIS, New York.

### BONDHOLDERS:

S. W. DUNNING, New York. CHARLES M. PRATT, New York.  
ESTATE OF WM. H. BOARDMAN, N. Y. C. C. NEWCOMB, Brooklyn, N. Y.  
H. D. HORTON, Brooklyn, N. Y.

SIMMONS-BOARDMAN PUBLISHING COMPANY,  
By E. A. SIMMONS, President.

Sworn to and subscribed before Harry E. French, Notary Public for Kings County, N. Y. (No. 15), whose certificate is filed with the County Clerk of New York (No. 13), and whose commission expires March 30, 1916, on September 17, 1914.

VOLUME 88 NOVEMBER, 1914 NUMBER 11

## CONTENTS

### EDITORIALS:

Manufacture of Special Devices.....	557
European Vestibule Connections.....	557
Efficiency of the Mikado Type Locomotive.....	558
Will the Compound Locomotive Be Revived?.....	558
Shop Facilities and Labor.....	559
New Books.....	559

### COMMUNICATIONS:

Standardizing Shop Practices.....	560
Melted Boiler Tubes.....	560

### GENERAL:

Boston and Maine Repair Shops.....	561
Result of Master Mechanics' Association Letter Ballot.....	570
Steam Locomotives of Today.....	571
Tests of Weathering of Pittsburgh Coal.....	572

### CAR DEPARTMENT:

European Vestibule Connections.....	573
Result of M. C. B. Letter Ballot.....	575
Safety Appliance Standards.....	576
Steel Caboose for the Pennsylvania.....	577
Wooden Cars in Freight Trains.....	581
Rock Island Lunch Counter Car.....	582

### SHOP PRACTICE:

Autogenous Welding.....	583
Recent Developments on the Frisco.....	588
Milling Machine Efficiency.....	593

### NEW DEVICES:

Rotary Air Compressor.....	597
Graphic Service Recorder.....	598
Chadwick Mail Car Faucet.....	599
Positive Locking Steam Hose Coupler.....	600
Fuel Oil Burner.....	600
Four-Feed Flange Oiler.....	600
Safety Fire Quencher for Blacksmith Shops.....	601
Portable Crane With Back Gear.....	601
Motor Driver Slotting Machine.....	601
Graphite Lubricator.....	602

### NEWS DEPARTMENT:

Notes.....	603
Meetings and Conventions.....	604
Personals.....	605
New Shops.....	606
Supply Trade Notes.....	607
Catalogs.....	608

### Manufacture of Special Devices

At certain of the mechanical association conventions during the past year statements have been made to the effect that the foremen are often handicapped in the

making of special devices and improvements to the machine tools by the lack of proper co-operation of the foremen in the other trades, whose aid had been solicited in making the different parts of the device. This, of course, is to be regretted, especially at this time when economy in shop production means so much to the railroads. Every foreman should seek to better the service whether the results of his labors will reflect directly to his credit or not, and the broad-minded foreman will do this. Perhaps the requesting foreman is at fault in asking his brother foreman to do something that is not covered by the proper shop order—something "on the side," as it were. The best method is to submit the plan of the proposed improvement to the general foreman, master mechanic, or superintendent of shops, as the case may be, and have the order for the work sent to the various other shops through the regular channels. By doing this no favors are asked, and there is some one in authority to see that the work is properly and quickly done. If the device is worth anything it is worth the consideration of the men who have direct charge of the shops involved in its manufacture, and it is to their interest, as well as the foreman making the request, to see that it is finished and placed in service as soon as possible. In other words, it is a matter of business, not of personal favor.

### European Vestibule Connections

Elsewhere in this issue will be found a description of a covered passageway for use between passenger coaches, which is in service in Switzerland. Because of the space

between the ends of the cars it is necessary to have a device that can be folded or extended for a considerable distance, and the bellows extension has been in general use for this purpose. Owing, however, to the length of extension which is necessary, this folding bellows consists of many more folds than the comparatively short device which is used on vestibuled cars in America. The necessity of folding and unfolding requires that the folds be kept free from cinders, snow and ice and it can be readily seen that this must be a difficult task; in fact, it is stated that a great deal of time is lost in clearing out the folds and in some cases it becomes impossible to close the extension at all. The improved arrangement consists of three frames with flexible connections, the frames being made of such sizes that they will fold together when not in use, the outer frame forming a pocket around the other two and their flexible connections. When extended and in use between cars the surface presented is comparatively smooth and there is little or no opportunity for the collection of cinders or snow. While it is claimed that this improved device is working out quite satisfactorily, neither the new



nor the old type is likely to appeal very much to American railroad men. Neither the connections themselves nor the adjustable platforms which are employed with them give the impression of strength and neatness of appearance inherent in the end construction of American passenger cars.

#### Efficiency of the Mikado Type Locomotive

Within the past three years the number of Mikado type locomotives in service in this country has increased greatly. On June 30, 1911, the Interstate Commerce Commission reported 652 of these locomotives in service. This number was nearly doubled by those ordered in the calendar year 1911, the number being 590. In 1912 there were 1,309 ordered and in 1913 there were 796 ordered. This would make approximately 3,000 Mikado locomotives in service on June 30, 1914, or an increase of about 460 per cent in three years. That this increase has been warranted is shown by tests made by various roads. Comparing the Mikado type with the Consolidation locomotive, the Chicago, Rock Island & Pacific has found that the average consumption of coal per 1,000 gross ton miles is 66 lb. for the Mikado as against 96 lb. for the Consolidation, or a decrease of 31 per cent in favor of the Mikado. Dynamometer car tests on the Chicago & North Western have shown a decrease of 18.7 per cent in fuel consumption per 1,000 gross ton miles (excluding resistance of locomotives) in favor of the Mikado. The Chicago Great Western has shown a saving of 36.8 per cent for the Mikado, the comparison being made from figures obtained from the service rendered by 10 engines of each of the different types for 12 consecutive months. In all three cases the Mikado locomotives were equipped with superheaters, but in only one case were the Consolidation engines thus equipped. That case was on the North Western, and this fact accounts for the difference in fuel economy on this road as compared with the other two roads. This does not mean that every Consolidation engine should be replaced by a Mikado, for there are occasions where the Consolidation locomotives can be used to better advantage. It does mean, however, that the Mikado type locomotive can replace the Consolidation locomotives with a marked saving in fuel economy in many instances, especially in through and fast freight service.

#### Will the Com- pound Locomotive Be Revived?

One of the contributing causes—and by a great many it is held to be the main cause—of the downfall of the compound locomotive was the difficulty and expense of the upkeep. It was not extremely difficult to keep a compound in such shape that it could be gotten over the road; but in most cases it proved very difficult and expensive to keep this type of locomotive in such shape as to obtain the advantages of compounding. Instead of the hoped for and prophesied advantages of the compound over the simple locomotive being realized, there were actually disadvantages. The trying out of the principles of compounding in American locomotive practice took place at a time when anything tending toward the increasing of the complexity of the locomotive was frowned upon; since that time conditions have changed. The complexity of the air brake system has increased threefold; the superheater has come into general use; the mechanical stoker has entered and passed the experimental stage and the compound itself has added its quota in the Mallet type. By adding to the amount of machinery about a locomotive these items have also added to the care and attention needed to keep it in proper operating condition. The superheater has been the cause of wonderful improvement in the economy of moving traffic, but there will still be calls for further economy when the superheater has reached its limit. The question then arises, what lines will the future development of the steam locomotive follow? Much has been accomplished recently toward increasing horsepower and at

the same time decreasing the weight per horsepower developed. American practice has been tending more and more toward refined lines and in that way, in some respects at least, has been tending more toward the ideas which obtain in Europe. The compound locomotive has met with considerable success on European railways and with the change in attitude which has taken place in this country during recent years toward increasing the amount of machinery on a locomotive, experiments embodying the use of compounding principles in connection with the superheater and the brick arch, while entirely a matter of speculation, would not seem to be unlikely.

#### The Training of Foremen

It has on occasion been remarked, and by men whose opinions in such matters should carry weight, that in order to be a successful executive one must be born with executive ability. We venture to disagree with this statement, while granting that the born executive is likely to prove more successful in the long run than one whose executive ability is the result of training and experience only. A case in point is that of a certain engine house foreman. The division master mechanic had never been able to obtain a foreman who could make a success at one of the smaller terminals. There were a number of reasons for this, including bad labor conditions. After several unsuccessful appointments a young man, then a machinist, was chosen as foreman and sent to this point to "clean it up," as the master mechanic expressed it. He made a dismal failure and had to return to work in the shop. Instead of giving him up as a bad job the master mechanic believed that he himself was at fault in starting the man in on a job that was too heavy for him, and a few months later the young man was given an opportunity to show what he could do as an assistant foreman. He filled this position most successfully for some time and succeeded to the foreman's position, but when left thus to his own resources and without the guidance of a foreman over him, he again went to pieces. He was again given an appointment as assistant foreman, and after another two years in this position was promoted to foreman. The experience of being twice set back had taught him his lesson and he is now one of the most successful foremen on this road.

We do not mean to claim that if every man who has failed to make a successful foreman had been treated in this way he would now be holding an executive position; there are men who will never make successful foremen under any circumstances. But this master mechanic had studied the young man. He was disappointed in the results of the first appointment, not so much in the young man as in himself for not using better judgment. He talked to him encouragingly and was not afraid on two occasions to give him another chance; indeed if he had failed the third time it is quite probable that he would still have had another opportunity to make good. We are quite aware that much experimenting of this kind would probably be expensive for a railway; but in this case the experimenting was justified by the results that have since been obtained. This man has for several years been in charge of a large roundhouse and has saved for the company much more than was expended or lost in his education. Moreover, he is now one of the principal members in a loyal, harmonious working force, an asset whose value cannot be computed.

There are many railway officers who, if a man fails in the first position to which he is appointed, give him up entirely as a bad job. No one would think of discharging an apprentice a month after he had entered on his apprenticeship course because he was unable to do a journeyman's work. Is it unreasonable to consider a man who is taken from the ranks and placed in charge of repairing cars and locomotives as a student of the art of directing men? Such a man, unless he be a born executive, is just as much an apprentice as he would be if he were starting in to learn his trade as a boilermaker or ma-

chinent; but it is ten to one that he will be placed in an out of the way terminal and left to his own resources. Aside from a brief talk by the master mechanic before he leaves for his new position he receives no assistance, and it may be weeks or even months before he receives a visit from his superior officer, and his correspondence will contain a large percentage of rebukes or requests to "please explain." Under such conditions, unless a man be a born executive and be possessed of more than the average amount of sand, there is no reason why he should succeed, and almost every reason why he should fail. The duty of the mechanical department officer towards a foreman should not end in his careful selection and appointment. In placing him in a foreman's position he has placed him in the position of a learner in the art of directing railroad work, and it is his duty to stand by him and assist him in every way possible in his study of men and conditions. The newly appointed foreman may be the master mechanic or superintendent of motive or master car builder of the future and his ability to fill such a position may depend, and in the majority of cases we believe it will depend, largely on the assistance given him during his early training as a foreman.

The master mechanic in the specific instance cited blamed himself more for the failure of the man than he did the man himself. He placed the man in an extremely difficult position; he did not go to the terminal with him, nor introduce him to any of the men with whom he would come in contact; he simply put the situation up to him and left him alone to do, or die. If the young man had had a guiding hand at that terminal during the first few weeks or even days he would probably have made good. The reasoning that a man should not receive assistance and coaching after he is appointed to the position of foreman, because the great majority of foremen have made good without such coaching, does not constitute an argument; if the thousands of men who have failed as foremen had received such guidance and instruction a large percentage of the failures would have been prevented.

#### Shop Facilities and Labor

During the past few years much attention has been given to scientific management. A great deal has been written from which it might appear that the human element was the prime factor in the problem. As a result there are a number of piece-work and bonus systems in operation, all designed to increase the output of labor by speeding up the individual. None of these, however, has succeeded in eliminating the uncertainty attaching to the human element. It is of interest in this connection to note what has been accomplished in a manufacturing establishment, the management of which has been working along entirely different lines. In the already well-managed plant of the Ford Motor Company, the labor time consumed in assembling each chassis was reduced from 12 hr. 28 min. to 1 hr. 33 min. by a campaign of improvement in shop facilities extending over a period of about seven months; and in accomplishing this result the effect of the labor element upon the output of the shop has been practically eliminated. The rate at which the completed cars are turned out is determined by the speed of an endless chain conveyor along which the chassis moves as it is assembled. Of course, such results are only obtainable in a plant of this kind where a uniform product is turned out, and the application of such methods to the average railroad shop would be extremely limited in scope. The fact should not be lost sight of, however, that the output of labor depends as largely on shop facilities as on the efforts of the individual. The economies often effected by slight changes in the arrangement of machine tools or by the adoption of special tools for certain classes of work are well understood. But the question of shop and inter-shop transportation is one of special importance, which has not been given the attention it deserves. The amount of labor expended in moving material, as it passes through the shop or from the yard to the shop, where the ma-

chine tools and buildings are poorly grouped, is often surprisingly high. It is true that in modern shop layouts much has been done toward increasing efficiency in this regard, but material transportation in and about the railway shop is still largely carried on by hand. The more flexible power transportation facilities, such as the monorail hoist and the storage battery truck, are finding considerable application in industrial plants and there is no reason why they should not be of great value in railway shops, especially where an ideal plant layout is impossible.

#### NEW BOOKS

*Proceedings of the International Railway General Foremen's Association.* Compiled and published by William Hall, secretary-treasurer of the Association, Winona, Minn. 193 pages, 6 in. by 9 in. Bound in paper.

The tenth annual convention of the International Railway General Foremen's Association was held at the Hotel Sherman, Chicago, on July 14, 15, 16 and 17, 1914. This book contains the complete report of the proceedings, including committee reports, papers and discussions. The association is to be congratulated upon the shortness of the time which has elapsed between the closing of the convention and the publication of the proceedings.

*Car Interchange Manual.* Compiled by J. D. McAlpine. 150 pages, 6 in. by 9 in. Bound in paper. Published by J. D. McAlpine, Cleveland, Ohio. Price 50 cents; \$4.50 per dozen.

This publication has been issued with a view of giving railway employees interested in the interchange and repair of cars, a condensed report of the decision of the Arbitration Committee of the Master Car Builders' Association from case one, rendered in November, 1888, to case 966 rendered in July, 1914. Those cases that are relatively unimportant are either omitted or abstracted without losing the meaning of the decision. There is included as a supplement to this book the Car Interchange Guide and Ready Reference Tables. This includes various prices of new and second hand material, such as couplers, wheels, axles, journal bearings, etc., together with the weight and the labor involved in installing the various detailed parts. A table of the value of wooden freight cars of different lengths is also included, as are tables of depreciation at various percentages. The M. C. B. rules are included, being grouped under various headings, such as air brakes, draft timbers, wheels and axles, improper repairs, etc. The arbitration decisions that affect each topic are also mentioned under these headings. The Car Interchange Guide and Ready Reference Tables is also published separately, the price being 35 cents, or \$3.50 per dozen copies.

*Experiments with Furnaces for a Hand-Fired Tubular Boiler.* By Samuel B. Flagg, George C. Cook and Forrest E. Woodman. Technical paper 34, Department of the Interior, Bureau of Mines. 32 pages, 6 in. by 9 in., illustrated. Bound in paper. Published by the Bureau of Mines, Washington, D. C. Copies free.

In the course of its investigation looking to increased efficiency in the utilization of fuels by the government, the Bureau of Mines has given special attention to the elimination of objectionable smoke from burning coals containing much volatile matter, such as are most readily available in many cities. With the increasing use of mechanical stokers at large boiler plants the problem of smoke abatement is becoming more and more that of assuring smokeless combustion with the hand-fired return tubular boilers commonly found at small plants. Six series of tests were conducted with a small horizontal return tubular boiler, in which several types of furnace arrangement were used. As a result of these tests several general conclusions, as well as others of more restricted application, have been drawn. The experiments indicate the possibility of designing hand-fired furnaces in which coal containing a large amount of volatile matter may



be burned without the production of objectionable smoke. More attention to the method of firing is required, however, than is given by the average fireman.

*Railway Fuel Association Proceedings.* 342 pages, illustrated, 6 in. by 9 in. Bound in morocco. Published by the association, C. G. Hall, Secretary, 922 McCormick building, Chicago. Price \$1; paper binding, 50 cents.

This book is the official proceedings of the sixth annual convention of the International Railway Fuel Association held in Chicago, May 18-21, 1914. It contains a very interesting address by Dr. W. F. M. Goss, reports of committees on Fuel Tests, Firing Practice and Fuel Stations. Also papers on Honeycomb and Clinker Formation, The Relation of Front End Design and Air Openings of Grates and Ash-pans to Fuel Consumption and Sparks, Uniform Methods of Computing Fuel Consumption, Sizing of Coal for Locomotive Use, Storage of Coal, Morden Locomotive Coaling Station, Reheating Locomotive Boiler Feed Water, Fuel and Failures, and Economies in Roundhouse and Terminal Fuel Consumption. These proceedings contain valuable information on the subjects above mentioned and may be considered authoritative in questions pertaining to fuel economy on railroads.

*Power and Power Transmission.* By E. W. Kerr, M.E., professor of mechanical engineering, Louisiana State University. Third Edition, revised. 373 pages, 6 in. by 9 in., illustrated. Bound in cloth. Published by John Wiley & Sons, Inc., New York. Price \$2.

The first edition of this book was published in 1901 and the second in 1907. It has now been revised and contains 24 more pages of matter and 61 more illustrations than the previous edition. The book is divided into three parts. Part 1, which deals with machinery and mechanics, contains an introductory chapter dealing with definitions, terms, etc., and the other chapters in this section consider such subjects as shafting, bearings, friction and lubrication, friction wheels, pulleys, belt gears, toothed wheels, the screw, cams, the lever and some of its modifications, link work and pipe fittings. Part 2 is devoted to steam power with chapters dealing with elementary steam power plants, the simple steam engine, automatic cut-off engines and high speed engines, indicators, compound engines, condensers, valves and valve gears, valve diagrams and rotary engines and steam turbines. Part 3 is devoted to pumping machinery, internal combustion engines, water power and compressed air.

*Administration of Labor Laws and Factory Inspection in Europe.* Bulletin No. 142, Department of Labor, Bureau of Labor Statistics, Washington, D. C. Bound in paper.

Recognition of the fact that the administration and enforcement of labor laws involve much more than a mere system of detecting violations of law is becoming more and more apparent. The establishment of definite rules and standards for the safety and health of workers, higher specialization of the functions of inspectors, and the creation in a number of states of industrial commissions with large powers are indications of the progress made. In view of the attention the subject is receiving in our own country the experience of foreign countries in the administration of labor laws and factory inspection is of interest. This bulletin is a report on the development and present status of factory inspection in Great Britain, Germany, France, Austria, Switzerland and Belgium, and shows that little progress in scientific standardization of safety and sanitation has been made in Europe. Inspection to detect violations of law is still the method used by most inspectors and most European inspection departments are far behind the more progressive departments in the United States in the matter of keeping records of inspections, violations of the law, etc.

## COMMUNICATIONS

### STANDARDIZING SHOP PRACTICES

WAYCROSS, Ga., September 14, 1914.

TO THE EDITOR:

In locomotive repair work it is important that the most economical practices consistent with turning out good work be used. On railroads having several shop organizations it is very often the case that each shop management has its own ideas and methods of doing certain operations, some of which are very good and others of which are very expensive. I believe it would be a paying proposition to appoint a practical mechanic to tour the entire system, visiting the various shops and studying the methods employed in making repairs and turning out work at each point. Considerable saving could be effected in this way by putting the best methods into general practice and eliminating local practices of a doubtful character.

There are other ways in which the services of such a man would prove of value. From time to time there are many instructions issued relative to changes in standards and making betterments of various kinds which are not always fully understood by all concerned, and much confusion and unnecessary expense often result. A man in the position referred to would be able to see that such instructions were correctly interpreted and carried out as intended.

H. C. SPICER,

Gang Foreman, Atlantic Coast Line.

### MELTED BOILER TUBES

COLUMBUS, Ohio.

TO THE EDITOR:

I have read the article in your August number relative to melted boiler tubes. A number of years ago I was roundhouse foreman of a large terminal and passed through two experiences of a similar nature.

The first resulted in the destruction of the flues and flue sheets, similar to the experience of X. Y. Z., it being necessary to cut the flues out in sections to remove them from the boiler. The cause was similar also, the engine having been damaged in the yard and brought into the house during the latter part of the night, at which time the roundhouse foreman discovered the presence of excessive heat; it required considerable time to stop combustion.

A few months later an engine was fired up about 1 p. m., after having been washed out without being refilled with water. Apparently a very good fire had been started before the trouble was discovered. The fire was immediately drenched in the firebox and all openings closed with the expectation that no further damage would be done. However, the engine was found to be generating excessive heat similar to the first engine referred to, and arrangements were at once made to place steam jets in the firebox through the ashpan. This steam was applied through the openings for from 12 to 15 hours before the engine showed evidence of cooling down; with the exception of a going over of the flues no further damage was done.

This may be of interest to those who may have a similar experience, and is a simple way of overcoming the trouble. Neither of these engines was equipped with a brick arch.

M. A. KINNEY,

Superintendent Motive Power, Hocking Valley.

THE SUBMARINE VESSEL.—The experiment with this machine will take place at St. Ouen, as proposed. The vessel was repeatedly sunk to the depth of 10 or 12 ft., and re-appeared on the surface at different points. M. Godde de Laincourt got into it, and remained there a quarter of an hour. He stated that he did not experience the least difficulty of respiration during his voyage under water.—*From American Railroad Journal, October 24, 1835.*

# BOSTON AND MAINE REPAIR SHOPS

## Analysis of Conditions Leading to the Construction of the Billerica Plant, With a Description

BY F. K. IRWIN

The need for new general repair shops on the Boston & Maine may be easily seen from a brief study of conditions and facilities existing prior to taking up the building and equipping of the plant at North Billerica, Mass.

In 1907 the Boston & Maine owned 1,100 locomotives, which on a basis of 80 per cent repaired per annum meant a monthly shop output of 73.3 locomotives. The figure of 80 per cent repaired per annum has been selected as a basis of requirements, as it permits repairs to all engines once in 15 months, and has been found to be good general practice. It is not advanced as a hard and fast rule, but as a fair basis for estimating.

To take care of this equipment the Boston & Maine had the following facilities:

Boston shops	.....	15 locomotives per month, Class 3 and 4 repairs.
Lyndonville shops	.....	5 locomotives per month, Class 3 and 4 repairs.
Keene shops	.....	17 locomotives per month, Class 3 and 4 repairs.
Concord shops	.....	25 locomotives per month, Class 2, 3 and 4 repairs.

Total ..... 62 locomotives per month, Class 2, 3 and 4 repairs.

There were no facilities for firebox and general boiler work and while Concord was rated as a class 2, 3 and 4 shop, this

of class three repairs, which in general constitute repairs to driving wheels, running gear, valve motion, and general machinery; there were no blacksmith or boiler facilities. The intent was to make this a nucleus for the main shop for the system.

The work of carrying out the plans, as far as developed for East Somerville, proved to be a slow process. In consequence the Boston & Maine employed a special engineer in 1910 with a corps of draftsmen and field engineers, whose exclusive duty was to work out the shop problem. One of the first decisions reached was to abandon further development at East Somerville for several reasons.

First, the ground was too congested to permit of future extension; the plans as worked out were very complete, in fact too complete, taking care of present needs but not allowing for expansion. The necessity for the constant use of a transfer table and a one entrance shop yard were, in themselves, not ideal conditions.

Second, anticipated electrification within a radius of 25 miles of Boston, made the location geographically poor from a steam

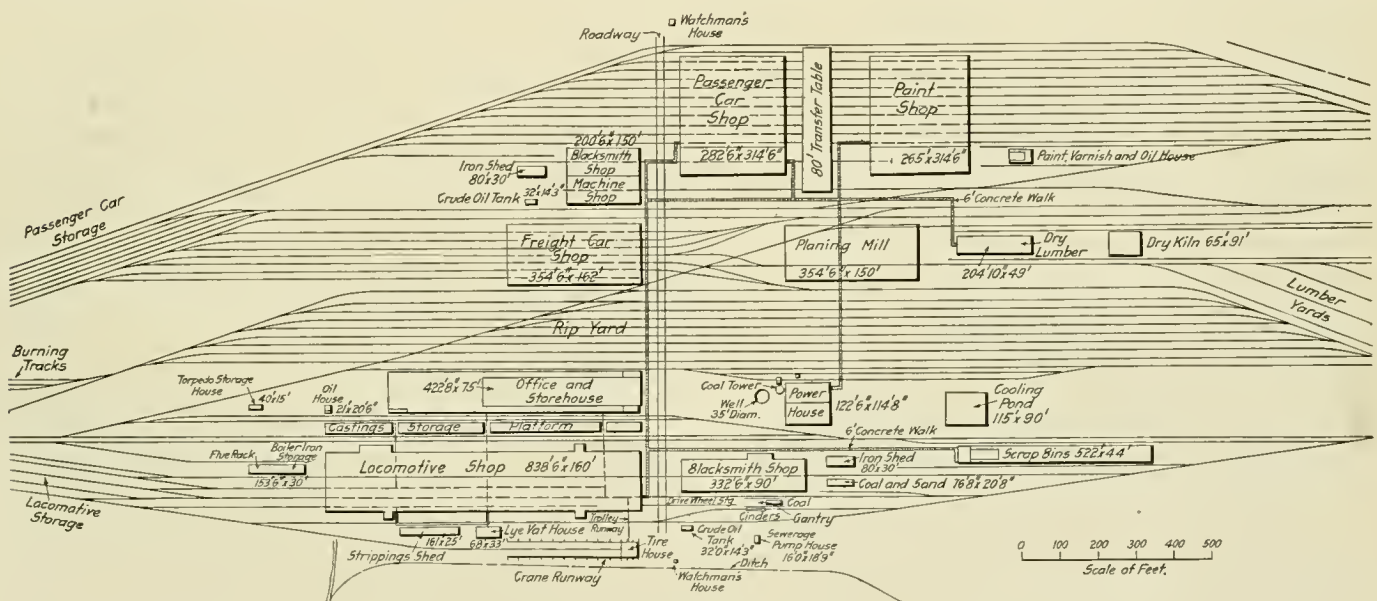

Plan Showing Yard Tracks and Grouping of the Buildings at the Billerica Shops

was the shop to which locomotives were sent for stripping the boilers for shipment to contract shops and where they were re-assembled on return; all firebox and heavy boiler work was, of necessity, done at some contract shop.

The Boston shops were destroyed by fire December 5, 1907, badly crippling the railroad in so far as repairs to equipment were concerned. Orders were given to develop plans for a general shop, to include, not only locomotive, but passenger and freight car repairs, the car situation being just as serious as the locomotive. The site selected was East Somerville, on a piece of property owned by the railroad, located on the Mystic river and contiguous to the main line tracks.

Small progress was made in actual development; a general layout plan was made and a building erected approximately 250 ft. long, containing ten repair pits and two low machinery bays. This building was equipped with traveling cranes and such machinery as was necessary to care for immediate needs in the line

locomotive standpoint, as all steam power would be kept in service outside of the electric zone.

Third, the East Somerville shop, as far as built, was considered excellent as to capacity, location, and equipment for a repair shop for electric locomotives and other equipment.

A shop site committee was appointed by Frank Barr, vice-president and general manager, consisting of Henry Bartlett, mechanical superintendent; A. S. Cheever, division superintendent; C. B. Smith, mechanical engineer, and F. K. Irwin, special engineer. This committee, after spending months in canvassing sites offered, finally decided to recommend the purchase of the property located at North Billerica. This site offered many advantages, among which may be mentioned ample area, least preparation of ground for buildings, accessibility, nearness to a labor market, being four miles from Lowell and near a trolley line; and situated as it is between the main line of the Southern division and the Bedford and Billerica branch, which form a



junction near North Billerica station, a shop approach was permissible from either end of the shop yard. The main shop track, 8,000 ft. long, completes the third side of a wye.

The field party under the direct supervision of S. P. Coffin, who was assistant engineer to the special engineer, began surveys for preparation of deed maps and topographical maps February 10, 1911, and the actual work of repairing locomotives

The Maine Central had approximately 240 locomotives and would require an output of 16 per month on the same basis of overhauling each engine once in 15 months; this increased the shop requirements for both roads to 106 locomotives per month. It was estimated that possible electric operation would release 89 engines of all classes for use outside the electric zone. This was considered a decrease in steam locomotive shop require-

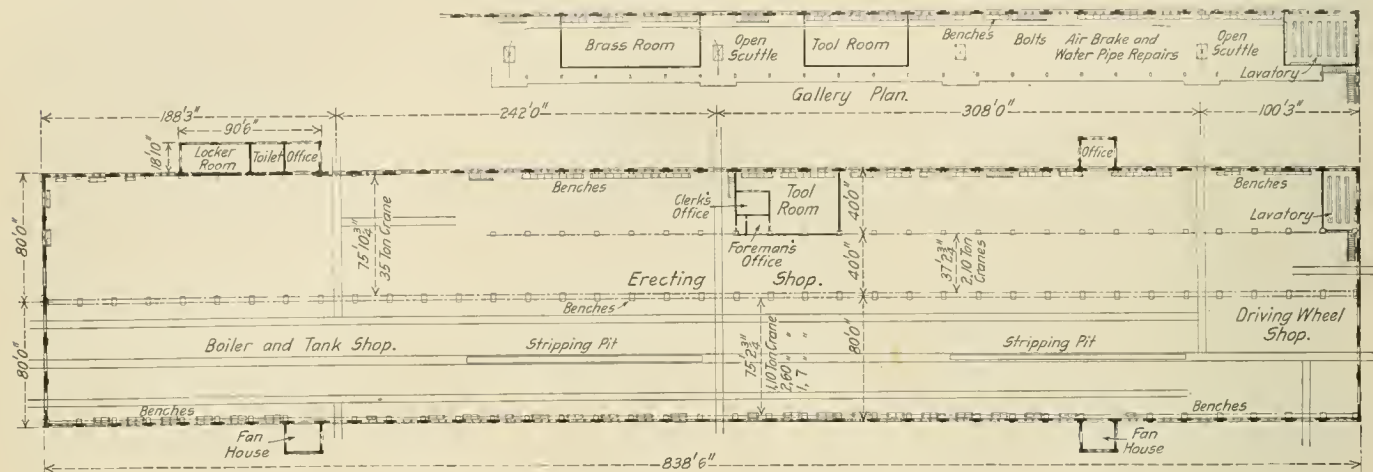

Plan Showing Arrangement of the Locomotive Shop

was begun February 9, 1914, three years from the time actual field work began.

The acquisition about that time of control of the Boston & Maine by the New York, New Haven & Hartford introduced a new feature in the problems to be solved and it was determined to co-ordinate or combine the shop facilities of the various roads making up the New England Lines. A careful study and exhaustive report on the shop situation was made by A. B. Corthell,

ments of six per month. The record of repairs passing through the shops indicated one-third first and second class repairs, necessitating firebox and heavy boiler work and extraordinary machinery repairs; two-thirds, third class repairs; leaving class four and five repairs to be taken care of at roundhouses.

On the Boston & Maine there were 2,100 passenger cars, including those on order. On account of the constant use of cars it was necessary to provide shop capacity to put the whole equip-



Tire Setting House and Monorail Hoist Runway from the Tire House to the Locomotive Shop

chief engineer. The essential features of this report being as follows:

Number of locomotives on Boston & Maine in 1911.....	1,261
Average annual increase for 5 years.....	77
Average taken out of service for 5 years.....	36
Net annual increase.....	41
Anticipated ownership, 1913.....	1,343
Shop output per month on Boston & Maine.....	90

ment through for all classes of repairs in seven months, or 300 per month. To avoid an accumulation of bad order freight cars it was deemed necessary to provide for 2,300 cars per month.

The following tabulation showed the then and anticipated output per month of Boston & Maine equipment, and the Billerica shops requirements to balance the work. This does not take into

consideration the possible release of locomotives by electric operation:

Shop Location	Locomotives		Passenger Cars		Freight Cars	
	Present	Proposed	Present	Proposed	Present	Proposed
Lyndonville .....	5	7	8	10	92	100
Keene .....	15	15	35	35	330	330
Concord .....	29	26	80	..	560	1,500
Fitchburg .....	3	5	..	..	..	..
Readville .....	6	8	..	..	..	..
Waterville .....	8	8	..	..	..	..
Portland .....	9	8	..	..	320	320
F. Somerville .....	..	..	..	..	..	..
Mystic Wharf .....	..	..	..	..	..	..
Total .....	75	77	123	45	1,302	2,250
Requirements .....	..	106	..	300	..	2,300
Billerica .....	..	29	..	255	..	50

From the above it was recommended that provision be made at Billerica for standing room for 20 locomotives in order to easily make first and second class repairs on 30 per month, depending on the Readville shops of the New Haven to take care of five class one and two. This being one-third the total requirements, and these two shops being the only ones equipped for firebox work, it was decided to send class three and four repairs to the other shops. The passenger car requirements for Billerica being 255 cars per month it was decided to provide shop capacity for 180 cars and take care of 75 light repairs in the passenger car yard. Freight car repairs were to be made at Fitchburg, making this a freight shop only. Space has, however, been allotted at

unless heavy work was done in the future to relocate the repair tracks.

As a matter of convenience in this description, the shop plan will be considered as lying north and south, with the top of the map west.

All buildings rest on concrete piles and with the exception of the office and storehouse are steel frame, with brick curtain walls and mill construction board roofs, with Barrett Specification gravel roof covering and the National Skylight & Ventilator Company's skylights. The office and storehouse rests on concrete piles and is of slow burning timber construction with mill construction roof. All auxiliary buildings are frame, designedly so, in order that they may easily be moved in the event of extending the main buildings.

GENERAL PLAN

East of the main shop is the stripping shed, divided into 20 stalls for the storage of pipe, fittings, and other strippings from the locomotives, until they are needed again. Directly opposite the center door on the east side is the lye cleaning house, a brick building with two concrete tanks or pools 10 ft. by 20 ft. by 6 ft. 6 in. deep. The tanks and floor of the cleaning house are served by a pneumatic crane of five tons capacity, spanning the full width of the house and traveling the full length.

Next in order is the tire house, a steel frame building with

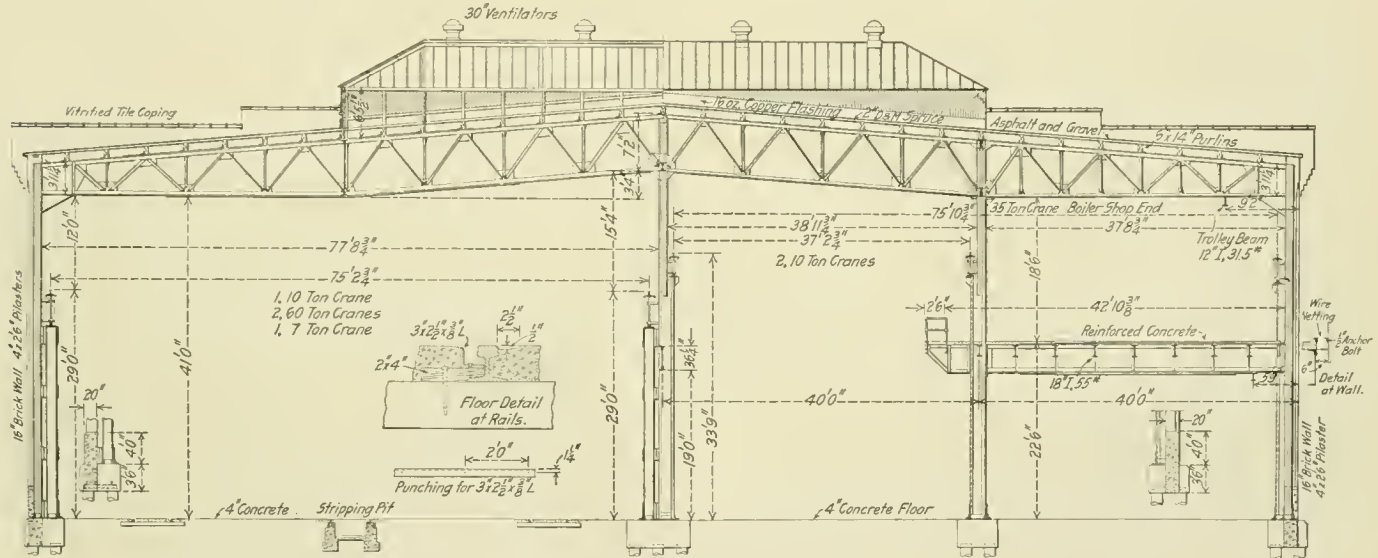

Cross Sections Through the Locomotive Shop

the Billerica shop site for both a mill and freight shop. The question of steel cars will have to be provided for in the near future and these two buildings will then be designed to meet steel car conditions. Repair tracks for taking care of running freight repairs have, however, been laid.

The general layout was made with a view towards keeping such buildings and branches of the work as are interrelated as conveniently located with reference to each other as possible and also so that future extension would not be interfered with. An examination of the general plan shows how each building may be extended without interfering with any of the others.

The repair yard tracks were located between what may be called the locomotive group and car group for two reasons; first, to have them as near the storehouse as possible as the repair yard is a heavy customer of the stores department; second, in order to get as long level tracks as possible at this location; and finally not to block the extension of the passenger car and paint shops. Had these tracks been placed west of the passenger car shops, the length would have been materially shortened, the transportation of mounted wheels would have become a serious problem, and the passenger car shops would have been blocked

corrugated iron sides and roof. This house is equipped with an oil furnace capable of heating eight tires at once, facilities for removing and putting on tires, an electric traveling crane bridge, 40 ft. span, with underhung single I-beam trolley, 7 tons capacity. Extending southerly from the tire house is a crane runway. The space within the runway area is for storing tires, wheel centers, axles, etc. A standard gage track extends through the length of the runway space. The operator in the trolley cage controls the movement of the crane bridge, trolley and a similar crane bridge in the north end of the locomotive shop. Material may be handled from cars to storage by means of this trolley, from storage into the tire house or into the locomotive shop, there being an I-beam runway between the tire house and the locomotive shop. The crane bridges having been properly lined and locked with this I-beam, the operator moves from one bridge to the I-beam runway thence to the other bridge, which he can then move up and down the shop at will, the bridge motor controller being in the trolley cab.

Dividing the shop grounds is a main thoroughfare 100 ft. wide running east and west. On the north line of this street and opposite the end of the locomotive shop are the blacksmith and



hammer shop, blacksmith iron shed and sand and coal storage. Coal and ash handling for locomotives and refuse from the blacksmith shop are taken care of by a traveling gantry crane with overhanging ends, fitted with a grab bucket. Coal is unloaded from the tenders into a bin. Ashes are deposited in a pit and handled to cars with the same outfit.

All scrap is under the control of the general stores department, and the scrap platform has been located for their convenience in handling, also for convenience in disposing of scrap from the repair yards and locomotive department.

The general store and office building is west of the locomotive shop. This building is provided with liberal platform space on the sides and at the south end, the main floor being 4 ft. from top of rail for convenience in unloading and loading cars. This is the general store for the system.

The power house is located in a line north of the storehouse room having been left for extension and also for storage of coal. South of the power house is a storage well of 100,000 gal. capacity. There are also eight 3-in. driven wells west of the power house. The elevated coal bunker is of 125 tons capacity, and is served with a skip hoist. The cooling pond is north of the power house.

The repair yard will have nine tracks with an average level length of 2,300 ft. each; five have been laid. These tracks are on 22 ft. centers, giving ample space for material and for working between the cars.

The car group of buildings occupies the westerly half of the property; beginning at the south end storage tracks for both passenger and freight cars and burning tracks have been provided. Space has been left for a freight repair shop planing mill as indicated. The dry lumber shed and dry kiln come next in order and then the lumber yard at the north end of the grounds. The car machine and blacksmith shop is situated south of the passenger car shop, and there are also provided

chine tools, group drives and lighting, with the exception of variable speed machines and general lighting. For variable speed machine tools direct current is furnished by a motor generator set consisting of a synchronizing motor and a direct current generator. Direct current for yard lighting and general shop illuminating is furnished by mercury arc rectifiers. It was decided to use 25 cycles, 3 phase, alternating current, in anticipation of the possible electrification of the line, which in all probability will be operated with current of these characteristics. This would



Store House and Office, North End

permit operation of the shops from the main power house. The heating system is the forced circulation hot water system.

#### LOCOMOTIVE SHOP

The locomotive shop is 160 ft. wide by 838 ft. 6 in. long outside, with a clear height under the bottom chord of the roof trusses of 41 ft. To support the steel columns, piles were driven in clusters, 22 ft. center to center of clusters, each pile being loaded

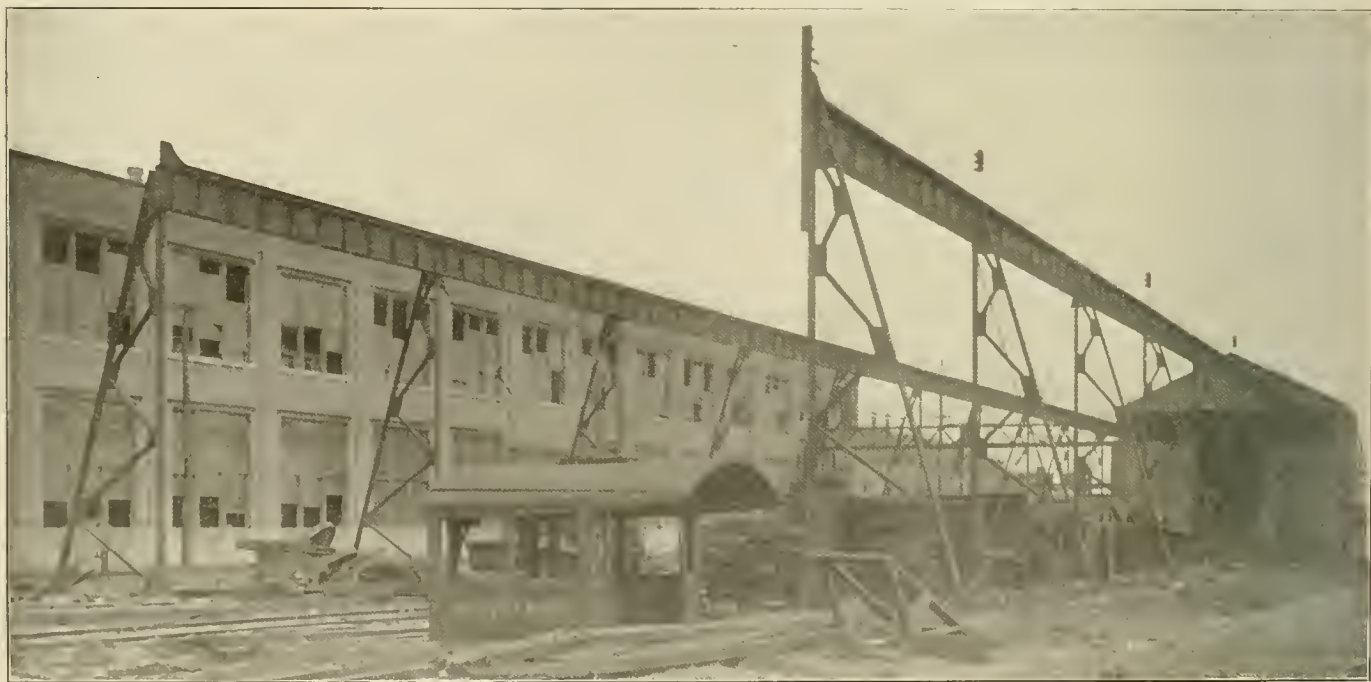

Tire Storage Yard and Crane Runway South of the Tire House

an iron storage house, 7,000 gal. fuel oil tank and coal house. This shop is expected to take care of all iron work for the car department, the fitting up of wheels, air brake equipment and steam hose, and pipe work.

Sewerage is collected in a waterproof sump and is then pumped to drainage and filter beds.

Current of 25 cycles, 3 phase, 550 volts, is supplied for all ma-

to 35 tons. The same method of construction was adopted for all buildings.

The locomotive shop is divided longitudinally by a center line of steel columns, the east half being allotted to the erecting shop, and the west to the machine shop, with the exception of 287 ft. at the south end, which is given up to boiler and tank work the full width of the shop. The erecting floor has three tracks run-

ning the full length, placed 25 ft. center to center in order to provide ample working space between engines.

The center or entrance track is intended for stripping and assembling, the two side tracks being the repair tracks; there are two stripping and washing pits, each 150 ft. long, in this center track. Without encroaching on the space allotted to the boiler shop at the south end or driving wheel work at the north end, it is possible to stand 20 engines end to end on these side tracks

being two of these cranes. These columns are carried through to the roof truss, dividing the truss into two spans. The gallery floor, extending from the north end of the shop to the boiler shop space at the south end, is reinforced concrete slab, supported by I-beam floor joists and steel girders. It projects beyond the line of columns and is provided with four landings for use in placing material in the gallery by means of the ten-ton cranes, which run on rails 33 ft. 9 in. above the main floor.

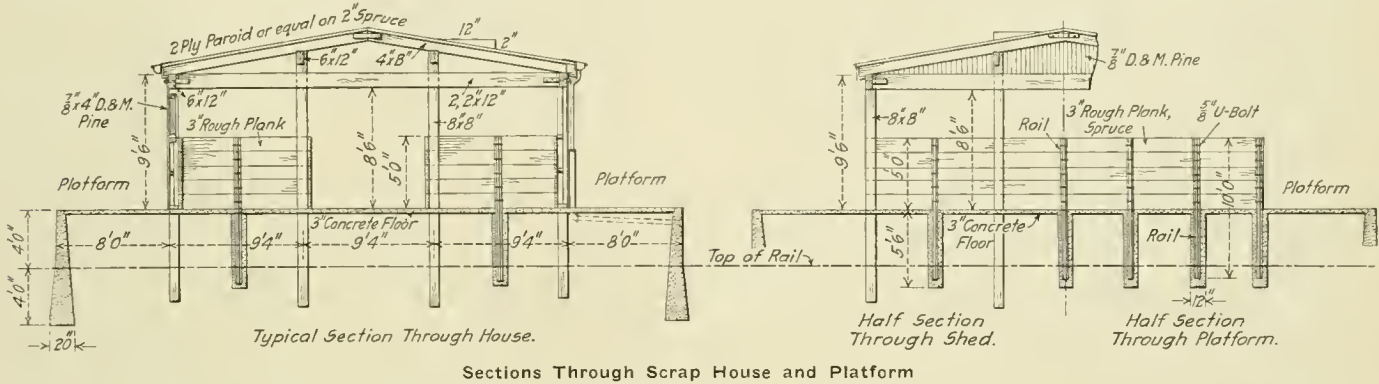

with ample space between engines. However, the superintendent of shops has adopted the expedient of standing engines in the herringbone fashion.

A space 100 ft. by 80 ft. at the north end of the erecting floor is devoted to driving wheel work. The facilities for removing and putting on tires are in a separate steel building east of the locomotive shop.

The erecting floor is served by two 65-ton capacity, 75 ft. 2 3/4 in. span, electric traveling cranes, each with a ten-ton auxiliary

Machines for driving box, shoe and wedge, valve motion and truck work have been placed under the gallery; also the tool room and the general foreman's office; while machines for brass work, finished bolts and studs, injector and air brake work and the manufacturing tool room are on the gallery. Light cab repairs and pipe work are also done on the gallery.

Pendant control trolley I-beam hoists, 1 1/2 ton capacity, electrically operated, run the full length of the gallery, both over and under, and serve the bench aisle between the machines and

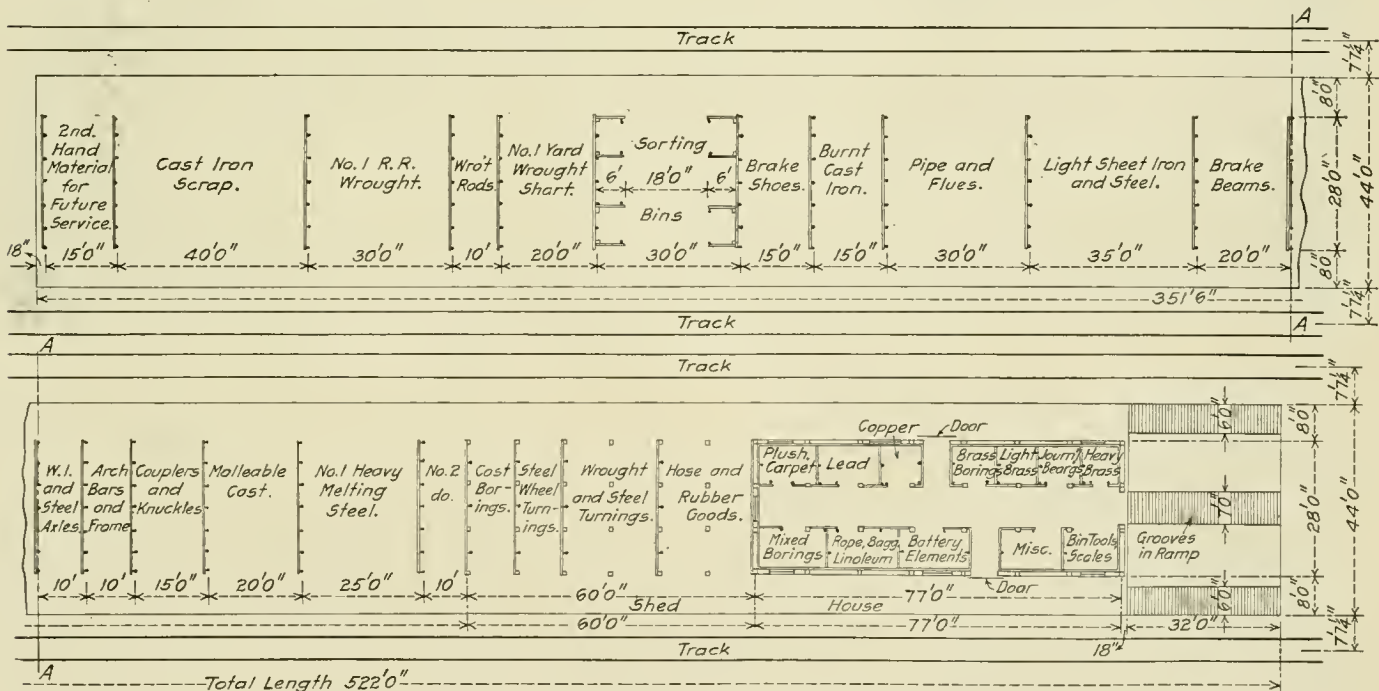

Plan Showing Arrangement of the Scrap Bins

hoist; one ten-ton, 75 ft. 2 3/4 in. span, electric traveling crane at the boiler shop end and a 7 1/2-ton crane bridge over the wheel shop end. All of these cranes may travel the full length of the shop. The height from the floor of the shop to the top of the crane rail on the runway girder is 29 ft.

The machinery bay is divided by a line of columns supporting the gallery floor and also supporting the girders for carrying the ten-ton cranes which serve the heavy machine floor, there

are wall benches. The trolley track over the gallery is provided with switches so that it is possible not only to serve the floor in a straight line, but also to serve both the main and gallery floor through open scuttles. The boiler tool space south of the gallery is served by a 35-ton electric traveling crane of 75 ft. 2 3/4 in. span. This crane, together with the heavy cranes over the erecting floor, covers the whole boiler shop floor space.

Locker and toilet facilities are provided in a lean-to on the west



side at the south end, on the main floor, on the gallery at the north end and on a mezzanine between the gallery and the main floor.

This shop was planned so that the hot blast system of heating might be used, and fan houses were built as lean-tos for this system. The economy of a forced circulation hot water system, together with the excessive cost of underground hot air ducts, determined the engineers to abandon the hot blast system. The fan houses have therefore been converted into foremen's offices and storage rooms for heavy tools.

Windows are large and frequent and the roof lighting is accomplished by means of glass roof monitors, 24 ft. by 80 ft., in alternate bays. Floor drainage and pit drainage is taken care of by a line of sewer pipe running to an open ditch on the east side of the shop yard area.

For convenience in serving mechanics with hand tools, lathe tools, etc., from the tool room and also to avoid loss of time by high-priced men congregating around the tool room window, a drop board telephone set is to be installed in the main floor issue tool room, with call stations conveniently located about the shops. The workman calls the tool room, makes known his needs and the requisite tool is sent to him by a boy who takes his brass check in exchange. This is also considered an excellent way to

weather. The open platform space is divided into 21 bins or spaces for sorting the various grades and kinds of heavy scrap. The bin partitions are of rough plank, 5 ft. high, and bolted by means of U-bolts to old rail posts which are in turn set in concrete bases.

#### OFFICE AND STOREHOUSE

The two-story brick store and office building, 75 ft. by 422 ft. 8 in., is built on a concrete platform which is 110 ft. by 672 ft. The floors and roof are supported by wooden columns and timber framing. The offices are on the north end, the first floor being assigned to the shop superintendent and the second floor to the local storekeeper and his clerks and to the telephone exchange. Communication between the two floors of the warehouse portion is by means of two stairways and two electric elevators. One elevator, for freight only, is of 4000 lb. capacity, while the smaller or combination freight and passenger elevator has a capacity of 2000 lb.

The first floor of the warehouse is assigned to heavy goods, fine goods such as plush trimmings, etc., being kept in a special room built for the purpose in the north end. The floor surface is granolithic concrete laid on sand.

Bins are arranged transversely, leaving a broad working aisle through the center of the building. At the end of each trans-



Store House Covered Shed at the South End

familiarize apprentices with the names, nature, and uses of tools. The workman has to return the tools at night. Another time saver is the location of the blacksmith tool dresser in the tool room.

#### BLACKSMITH SHOP

The blacksmith shop is a one-story steel frame and brick building 90 ft. by 332 ft. 6 in., with a clear height under the trusses of 20 ft. Locker and toilet rooms are in a leanto on the west side. The roof trusses span the full width of the shop and are designed especially heavy to permit carrying a load of five tons on any point on the bottom chord, the object of this being to provide for supporting line shaft and pulleys, overhead circular cranes, etc., there being no crane masts anywhere in the shop. This building is a combination hammer shop, general blacksmith, forging and bolt shop.

#### SCRAP PLATFORM AND BINS

The scrap platform is built of concrete, backfilled with sand between the walls, and with a concrete top. It is 44 ft. wide, 522 ft. long and 4 ft. high above top of the rail, with a ramp on one end. There is a house on one end 28 ft. by 70 ft. for brass, copper borings, trimmings, etc., which might be affected by the

verse aisle between the bins is a window, so that there are no dark corners. All bins, shelves, racks and benches were designed for the purposes for which they were intended to be used and are built throughout of steel. The height has been kept down to six feet, so that the use of ladders to reach material is avoided. The second floor is a double wooden structure carried on wooden girders and floor joists, the bin and rack arrangement being similar to that on the first floor.

#### POWER HOUSE

The power house is a steel frame and brick structure 114 ft. 8 in. by 122 ft. 6 in. divided longitudinally into boiler and engine rooms, with a pump basement, pipe tunnel and ash tunnel in the boiler room side. The boiler room floor is at yard grade and the engine room floor is elevated 8 ft., providing space under the floor for piping and electric cables. There are five Babcock & Wilcox 508 hp., vertical header boilers, designed for 200 lb. pressure and with safety valves set at 150 lb. All of the boilers are equipped with Babcock & Wilcox superheaters, designed for 140 deg. superheat forced rating. One boiler has been provided with plain grates for hand firing and burning shavings and refuse from the planing mill, while four have Murphy stokers.

The induced draft is provided by a B. F. Sturtevant Company 14 in. by 7 in. fan, of a capacity of 175,000 cu. ft. of air per minute. A National feed water heater and oil separator is used.

The engine room equipment consists of two Providence Engineering Works, Rice-Sargent Corliss, horizontal, twin, single expansion, non-condensing engines for direct connection to gen-

2,150 cu. ft. of free air per minute at 100 r. p. m.; one Alberger Pump and Condenser Company's Giroflow jet condensing equipment; and one ten-ton hand power traveling crane.

The heating load on the plant being far in excess of the power load, compounding the engines was not considered desirable from an economic standpoint. The exhaust from all apparatus in the power house is conducted to the heaters, which are designed with sufficient volume to relieve the engines of back pressure. Economies during the period of no heating are obtained by shutting down one or both of the main engines, and putting the turbo-generator into service. The mixed pressure turbo was installed in order to provide against the insufficiency of low pressure steam on account of the intermittent action of the air compressors and possibility of shutting down other steam auxiliaries.

#### LUMBER SHED

The lumber shed is a frame building 49 ft. wide by 200 ft. 10 in. long, with a center aisle 16 ft. wide running the full length, and a ventilating monitor also running the full length. The shed is built with two storage decks, the heavier material to be carried on the lower floor, the sides are provided with continuous sliding doors below and swinging doors in each bay for the upper deck.

#### DRY KILN

The dry kiln is built of brick with canvas curtain doors, tiled ceiling and concrete floor. It is 63 ft. by 91 ft. and divided into five drying sections. The building was constructed in accordance with plans furnished by the Andrews Dry Kiln Company, and all equipment was purchased from them. The temperature, humidity and rate of drying is in absolute control of the operator. Steam coils are placed near the floor and condensing coils on the sidewall in chambers provided for the purpose. Above the concrete floor is a wooden floor with openings running the full length of the kiln; this floor serves the twofold purpose of a walk and baffle. The lumber is piled on trucks which run over rails carried on pedestals. These trucks may be transferred with their loads to another standard gage outside truck with rails running crosswise, for transporting the dried lumber to the shops or lumber shed.

Hot air rises through the slotted openings in the floor in and around the piles until it reaches the roof; the condensing coils,



Pipe Supports, North End of Passenger Car Shop

erators. The cylinders are 16 in. by 30 in.; two General Electric Company 20 pole, 350 kw. alternating current generators with field rheostats, direct connected to the Rice-Sargent engines; two General Electric Company exciter sets consisting of marine type engines and 50 kw. 125 volts, 280 r. p. m. compound wound direct



Car Machine and Wheel Shop

current generators, direct connected and mounted on the same base; one General Electric Company marine type engine and generator set with direct connected exciters; one General Electric mixed pressure turbo-generator set; one General Electric synchronous motor generating set; two General Electric 50-light series mercury arc rectifier sets; one General Electric 14 panel switchboard; two Laidlaw-Dunn-Gordon air compressors, capacity

which have cold water running in them, induce a downward current in the condensing chamber; moisture picked up by the hot air is deposited on these coils, and the drip is carried to suitable drains by means of copper troughs running under the condenser coils. The rate of drying is simply a question of temperature. As different kinds of lumber require different treatment, suitable valves, regulators, thermometers and hydrometers



permit a nicety of adjustment for the proper treatment of any given wood.

CAR MACHINE AND BLACKSMITH SHOP

The car machine and blacksmith shop is a brick building with steel frame, 150 ft. by 200 ft. 6 in., divided longitudinally by a brick wall in which are wide doorways, one section being assigned to blacksmith work and the other to machine and wheel work. The design was decided on because of the close relationship between the two departments. The building is so located that the progress of the material may be either to the passenger car repair shop or freight repair yard in a direct line.

PASSENGER CAR SHOP

The car repair and erecting shop is a brick building 314 ft. 6 in. by 282 ft. 6 in. The one story erecting shop proper is 240 ft. 6 in. by 282 ft. 6 in. containing ten tracks spaced 24 ft. center to center. The steel roof framing has been designed so that lighting

design and there are ten tracks 24 ft. center to center in the one story portion. The three easterly tracks are used for washing cars and are lower than the others and the concrete floor is graded to floor drains provided with screens. These empty into catch basins which in turn are connected with a drainage line leading to the old canal. On each side of each paint track counterweighted adjustable scaffolds have been erected.

TRANSFER TABLE AND PIT

The transfer pit is 80 ft. wide by 385 ft. long and 2 ft. deep from top of rail to top of rail. This pit is constructed with concrete side walls, reinforced supporting walls running lengthwise of the pit and all carried on concrete piles. There are five lines of tracks dividing the table into four bays, resting on yellow pine stringers which are bolted to the supporting walls. The transfer table, built and installed by George P. Nichols and Brother, is designed to handle a 75-ton car and a 117-ton switch engine: it

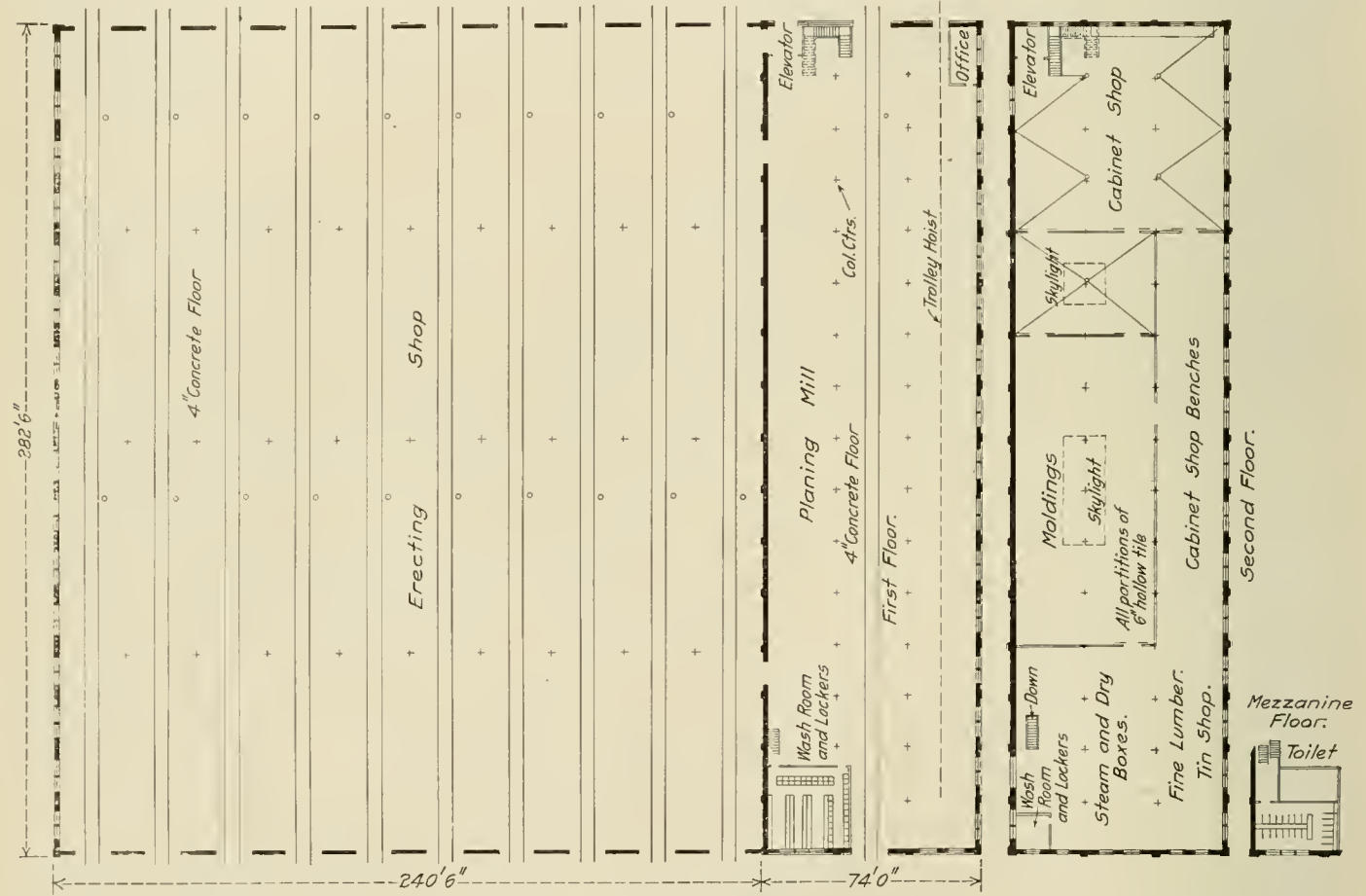

Floor Plan of the Passenger Car Shop

is between the cars instead of over them, there being four skylights or monitors in each bay between tracks. The two story portion is 75 ft. by 282 ft. 6 in. The first floor is used for the planing mill and will eventually become the cabinet shop, when the planing mill and freight shop are built. The second floor is used for cabinet shop, cab work, storage of kiln dried fine lumber and mouldings used for coach trimmings, steaming and drying boxes and tin shop. Communication between floors is by means of two stairways and an electric elevator. A trolley I-beam is hung on the underside of the girders supporting the second floor, projecting beyond the building; a chain hoist trolley runs on this beam for bringing heavy sills and other timbers to the woodworking tools.

PAINT SHOP

The construction of this building is the same general type as the passenger car shop; the lighting arrangement is of the same

is equipped with a 52 h. p. motor. Current is taken from overhead wires by means of trolleys mounted on a gas pipe pole at one end of the table.

PAINT, VARNISH AND OIL HOUSE

There are two oil houses, but for the purpose of this article the larger one for the storage of paint, varnish and oil will be considered, the essential features being the same in both, the smaller of the two being used as an issue house for the locomotive shop only. This oil house is built of brick on an elevated platform and has a basement under it, the floor is carried on a steel frame and is of reinforced concrete, as is also the roof. Ventilation is provided by monitors in the roof, a ventilating stack from cellar to roof, and floor registers in the side walls of the main building. All heating pipes are in the cellar. The extension of the platform with cover shed is for caring for empty barrels. A steam pipe with valve outside is brought in the building so that

in case of fire, opening this outside valve will fill the interior with steam. All storage tanks are in the basement, there being 21 in all and on the main floor ranged along the end wall are self-measuring and recording pumps, etc., while in the floor are filler openings covered with brass floor plates. The whole equipment was installed by the S. F. Bowser Company, Fort Wayne, Ind.

taken care of by a tool committee. Valuable assistance was rendered this committee by L. R. Pomeroy, who was retained in a consulting capacity and made one of this committee.

Mr. Pomeroy carefully checked the rated output of each machine against the expected requirements and made a complete analysis of the motor and power problems. Studies made on

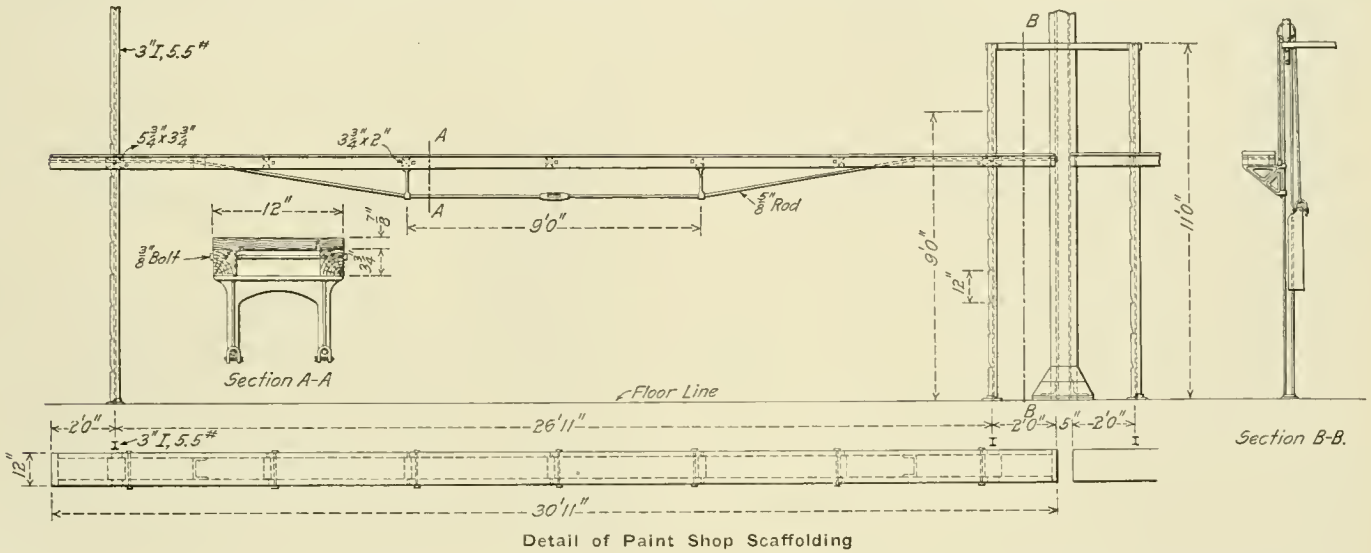

Detail of Paint Shop Scaffolding

MACHINERY AND TOOLS

The determination of the proper machine for a given piece of work, the number and size of each kind of machine requisite for

similar lines for the Lackawanna\* were taken as a guide, checked up and adapted to Boston & Maine conditions as far as the locomotive department was concerned. Use was made of a thorough

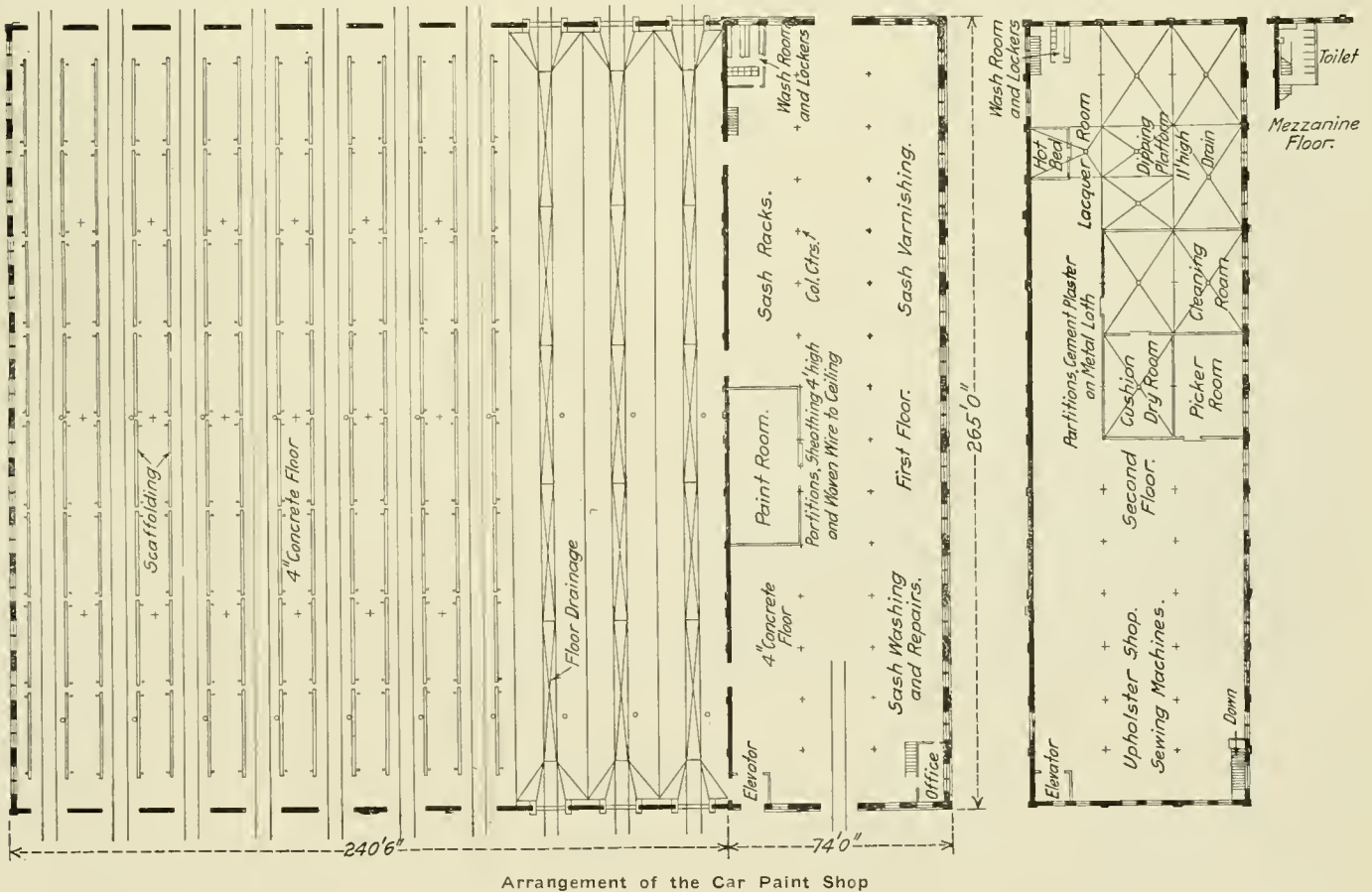

Arrangement of the Car Paint Shop

the anticipated shop output, tabulation and canvass of machine tool bids, adoption of motors of proper size and type for both individual machines and group drive, and the selection of hand tools, such as taps, dies, reamers, wrenches, air tools, etc., was

study made by Mr. Pomeroy of machine output in the Fitchburg shops for arriving at the car department equipment.

The problem, apparently simple, but involving considerable

\*See American Engineering & Railroad Journal, April, 1909, page 120.



study was to make 30 general locomotive repairs and 180 general passenger car repairs per month. To begin with, selection was made of one of the heaviest locomotives, the various operations considered and listed, and the proper tool equipment in kind and quantity selected. This list was then carefully checked for machine output and where it was found that some of the machines were not assigned a fair proportion of the work and their determined location in the shop was such that one of similar nature was conveniently near, the particular machine was eliminated from the list. Efforts were directed towards getting a well balanced shop. It was presumed that by taking the heaviest type locomotive as a basis, enough leeway would be provided by the interjection from time to time of smaller engines, to provide for accidental contingencies and also manufacture standard parts for the smaller division shops. A certain latitude was also provided for growth or betterment of schedule. The car department study was worked out on the same lines.

The proper motor capacity was carefully checked, consideration being given to the fact that machine tool manufacturers invariably equip their machines with motors of sufficient power to meet the maximum output of which the machine is capable. For example, axles, piston rods, etc., are purchased rough turned, with a minimum amount of metal left for finishing; this may be considered the finished product of the rolling mill whereas it is the rough stock of the railroad shop. It is evident, therefore, that a lathe for finishing any of these parts would not require as high powered motor equipment as one for service in a rolling mill. The same reasoning was applied to group drive motors. The aggregate power required by all tools in a group was determined and consideration was given to the intermittent operation of the tools in the group; motors were then installed of approximately 25 to 30 per cent of the total power when all tools were in operation at the same time. This can safely be done on account of the large overload capacity of alternating current motors;

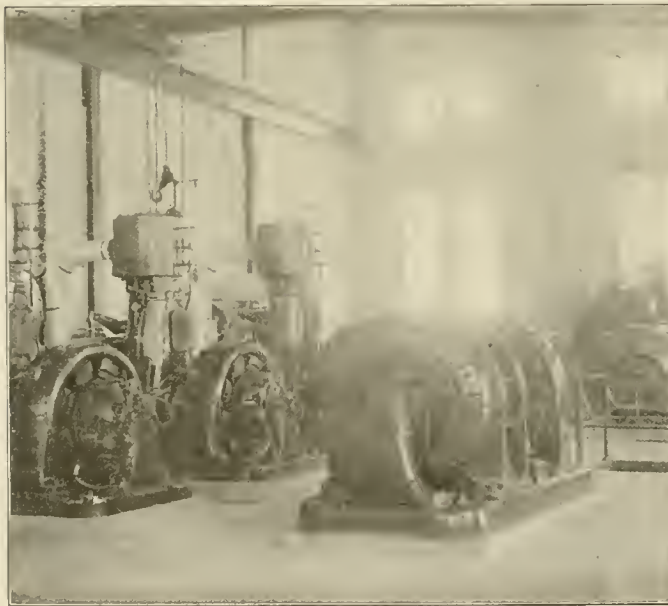

Interior of the Engine Room

further, the result of observation of motor operation in shops very similar to the Billerica shops has demonstrated that this practice is good.

Group drive motors are carried on steel brackets and shelves riveted to the steel columns supporting the shop roof. This arrangement leaves a clear way over the wall benches and in the bench aisle, permitting the use of I-beam trolley hoists in this space without the interference of the belts.

The line shaft is 2 15/16 in. diameter, running at 200 r. p. m. in boxes fitted with Hyatt roller bearings; it is put up to true line

and level, throughout the full length, being sectioned for each group of machines. Sections average 44 ft. in length and are made up of two or more pieces of shaft 22 ft. long. Flange couplings are used and a space of 1/2 in. has been left between the ends of sections; provision has been made for connecting the whole or a part of each section to the one on either side, 1/2 in. fillers and bolts having been provided for this purpose. This precaution was taken to provide against the loss of use of a whole group of tools in the event of mishap to the motor driving



Power House, Showing the Coal Tower

it. Motors were purchased with pulleys standard to them and proper pulleys put on the line shaft to maintain the same speed in each group.

The equipment of these shops was made as complete in every detail as it was possible to foresee. There was installed not only a full complement of machine tools but all necessary small or hand tools were purchased or made in other division shops, and held in readiness for use when needed. The long delays incident to the opening of a new shop occasioned by the necessity of either making or buying jigs, wrenches, blacksmith tools, taps, dies, reamers, etc., was avoided. The railroad also took the precaution to train a force in other division shops to man the Billerica plant, so that when orders were given to start, the actual work of repairs began at once.

## RESULT OF MASTER MECHANICS' ASSOCIATION LETTER BALLOT

The secretary of the American Railway Master Mechanics' Association has issued circular D, giving the result of the letter ballot of subjects voted on as the result of the convention at Atlantic City last June. Ten subjects were considered, and all were adopted, as follows: Castle nuts, change in specifications for steel tires, solid wedges in 5 in. by 9 in. and 5 1/2 in. by 10 in. journal boxes, formula for main and side rods, the 6 in. by 11 in. journal box and contained parts, specifications for alloy steel forgings, specifications for quenched and tempered carbon-steel axles, etc., code for laboratory and road tests of locomotives, air brake and train air signal instructions, and the elimination of questions and answers regarding the use of air brake and train air signals. The discussion on these subjects was published in the *Daily Railway Age Gazette* of June 16, 17 and 18, 1914.

UNEMPLOYED IN GERMANY.—The largest labor union in the Berlin district, Germany—that of the metal workers, with 88,000 members—reports 11,000 unemployed, although some 16,000 members are with the troops in the field.—*Iron Age*.

## STEAM LOCOMOTIVES OF TODAY

The sub-committee of the railroad committee of the American Society of Mechanical Engineers has prepared a report in the form of a paper for presentation at the annual meeting. The report is signed by G. M. Basford, F. H. Clark and W. F. Kiesel, Jr., and will be presented in the afternoon of Wednesday, December 2, 1914, at the rooms of the society, 29 West 39th street, New York, when a full discussion is invited. The report in full is given below:

Recent progress and improvement in the efficiency and capacity of steam locomotives has been of such remarkable character and extent that a record in the proceedings of this society is justified.

Steam and electric locomotives as rivals in the same field has been a favorite subject for discussion before engineering societies, and it is easy to start arguments in favor of each of these rivals among the partisans interested. Whether or not the steam locomotive is to be displaced by the electric is, of course, an important question which will in time be settled by the court that settles all such questions, that of the treasurer's figures. For the present and for the immediate future the burden of transportation falls and will continue to fall upon the steam locomotive. If the steam locomotive is to be perpetuated it is fitting that it should be improved to the utmost limit. If it is to be finally displaced it is fitting that it shall be so improved in order that progress to something better shall be intelligently developed upon a solid foundation. This discussion will be confined to the steam locomotive, its progress in the recent past, and its possibilities for the near future.

### PROGRESS IN CAPACITY

While efforts individual in character and extent were made in this country before that time, the first consistent and systematic plan to secure the utmost power of locomotives within given restrictions of weight and cross-section clearance was inaugurated 20 years ago. This plan began with an eight-wheel or American type passenger locomotive, built for an eastern railroad in January, 1895. This locomotive weighed 116,000 lb., with 74,500 lb. on driving wheels. It provided a tractive effort of 21,250 lb. While this locomotive was not the most powerful in passenger service at that time, it was the first of a chain of passenger locomotives leading in a connected series by the same builders, up to and including recent designs of the Mountain type, representing the largest passenger type of present practice. This type has four-wheel leading trucks, eight driving wheels and two trailing wheels. The largest of the Mountain type weighs 331,500 lb. with 240,000 lb. on driving wheels and produces a tractive effort of 58,000 lb., or about three times the tractive effort of the first design of the series built during a period of 20 years.

In the year 1898 the engineering and railroad world was interested by the appearance of the largest and most powerful locomotive built up to that time. This was of the Consolidation type with a two-wheel leading truck and eight driving wheels. This locomotive was built in Pittsburgh, and for a number of years was the largest and most powerful of its type, and the largest and most powerful locomotive in the world. Its total weight is 330,000 lb., weight on drivers 208,000 lb. and tractive effort 53,300 lb.

Today the most powerful freight locomotive has two leading and two trailing wheels and 24 driving wheels. It gives a tractive effort of 160,000 lb. and weighs 410 tons. This locomotive has hauled a train of 251 freight cars weighing 17,912 tons, exclusive of the locomotive. The total length of the train was 1.6 miles, the maximum speed attained was 14 miles per hour. This required a maximum drawbar pull of 130,000 lb. This locomotive has six cylinders and three groups of driving wheels.

A freight locomotive has recently been built having two cyl-

inders and a single group of driving wheels which develops a tractive effort of 84,500 lb. Such has been the progress in capacity.

This progress has been rapid, perhaps somewhat too rapid with respect to improvements in operating facilities and progress in other features of railroad equipment. It has been rendered possible by corresponding developments of factors making for greater efficiency in boilers and in engines. During the past 20 years in this country locomotive development in capacity and in efficiency, particularly during the past five years with respect to efficiency, has been remarkable, and is worthy of record with progress in marine and stationary engineering.

In Europe the relatively high cost of fuel led to efforts to improve efficiency before this problem aroused serious attention in this country, but physical limitations more rigidly restricted the size and weight of locomotives in Europe. Our problem is to secure maximum efficiency combined with great size, great weight and great power which is more difficult. Since the development in the size and weight has been tremendous, even though these limits may not yet have been reached, it is now appropriate to concentrate on efficiency.

For a number of years the physical capacity of the fireman to shovel horsepower through the fire door determined the capacity of the locomotive at speeds. Mechanical stokers have removed that limitation. It is now possible to fire six tons, and more, of coal per hour into a locomotive firebox. This has changed the problem into one of getting the maximum amount of heat out of the coal and using it economically in the cylinders. With the large figures now prevailing for drawbar pull and weight it is fitting that closest attention should be given to the best possible use of every pound of metal and every pound of coal. Due to recent application of several economy producing and capacity increasing factors great improvements have already been made with promise of more to come. Then the great work of building up the efficiency of the average locomotive to the standard of the best will follow.

Among these economy producing and capacity increasing factors are the following improvements:

- Boiler design in the relationships of the factors making up heating surface;
- Firebox design;
- Front end design, draft appliances, exhaust nozzles;
- Ashpan design as to air openings;
- Superheating;
- Compounding;
- Feedwater heating;
- Firebrick arches and circulating supporting tubes;
- Valve gear;
- Detail design to secure reduced weight of reciprocating parts and other parts;
- Use of high-grade alloy steels to reduce weights;
- Mechanical stokers;
- Labor-saving devices for the engineman and fireman;
- Improved counterbalancing to permit of greater weight on driving wheels by reducing dynamic stresses;
- And yet to come is powdered fuel with possibilities unknown in scope and in importance. Powdered fuel is in reserve, promising the ideal method of complete combustion under control more perfect than is possible with present methods other than oil burning and perhaps with economies impossible to obtain with oil.

### PROGRESS IN EFFICIENCY

Valuable comparisons may be drawn from the best results of ten years ago and of today. At the Louisiana Purchase Exposition in 1904 the tests made by the Pennsylvania Railroad revealed important figures concerning locomotive performance at that time. It was shown to be possible to obtain equivalent evaporation from and at 212 deg. of 16.4 lb. of water per sq. ft. of heating surface, indicating the power of locomotive boilers when forced. It was shown that when the power was low, the



evaporation per pound of coal was between 10 and 12 lb., whereas the evaporation declined to approximately two-thirds of these values when the boiler was forced. These results compared favorably with those obtained in good stationary practice, whereas the rate of evaporation in stationary practice lies usually from 4 to 7 lb. of water per sq. ft. of heating surface per hour. In steam consumption the St. Louis tests showed a minimum of 16.6 lb. of steam per i. hp. per hour. In coal economy the lowest figure was 2.01 lb. of coal per i. hp., the minimum figure for coal per dynamometer horse power was 2.14 lb. These records were made after the superheater had become a factor in locomotive practice and they represent economies attained by aid of the superheater in one of its early applications. This is important in the light of the recent development of the superheater. These remarkable figures have never received the attention which they deserve from engineers. They serve, however, to show that 10 years ago a steam locomotive had attained results which were worthy of the best attention of the engineers of the time. Since then greater progress has been made and today locomotives of larger capacity than those concerned in the St. Louis tests have given better results.

Voluminous records of recent investigations of locomotive performance taken from the Pennsylvania Railroad test plant at Altoona show that the best record of dry fuel per i. hp. hour down to the present date is 1.8 lb., with a large number of less than 2 lb., while the best performance in dry steam per i. h. p. hour is 14.6 lb. with a large number less than 16 lb. A reduction of 10 per cent in fuel and 12 per cent in water is remarkable as the result of a development of 10 years. This coal performance was recorded by a class E6S Pennsylvania Railroad locomotive while running at 320 r. p. m. and developing 1,245.1 i. hp. The same locomotive gave a fuel rate of 1.9 lb. while running at the same speed and developing 1,750.9 i. hp. The best water rate was given by a class K2SA Pennsylvania Railroad locomotive while running at 320 r. p. m. and developing 2,033.1 i. hp. These high powers indicate that the locomotives were not coddled as to output of power in order to show high efficiencies, but that high efficiencies accompany actual conditions of operation in severe service. As to power capacity expressed in terms of evaporation, it is interesting to note that the maximum equivalent evaporation from and at 212 deg. per sq. ft. of heating surface per hour on the Altoona test plant is 23.3 lb. These figures of high efficiency were obtained from locomotives which represented not only very careful, general and detail design, but their design included several of the improvements making for greater capacity and higher efficiency, without which the results could not have been attained.

Having in mind the facts that steam locomotives are power plants on wheels, built to meet rigid limitations of weight, both static and dynamic, and that the use of condensers is impossible, engineers in general must admit the high character of the work of locomotive designers which has attained these results.

Greater efficiency, which is revealed on the test plant and through reports of engineers, would be important because it proves that progress is being made in the possibilities of locomotive performance. Improvement which is revealed by operating statistics and which, therefore, appears in the records of the treasurer's office is the real test in this case. It is important to know that increased power of locomotives, attained largely through the development of economy-producing and capacity-increasing factors, has produced results which the financial reports of railroads prove beyond question. A recently published list of train tonnage on 45 prominent railroads indicates that 16 of these roads have increased their average freight trainloads by over 30 per cent during the last five years. Credit must be given to the improvement in the locomotive for most of this development. These figures reveal the value of increased power and efficiency of steam locomotives and the end is not yet in sight.

#### WHAT REMAINS TO BE DONE

American locomotive development to its present state would have been impossible without the use of the improvements already mentioned. It is believed that all these are capable of still further development, making for still greater economy in the use of fuel and, therefore, promising greater power capacity. It is the object of the committee to present these possibilities for discussion by those who are engaged in perfecting and improving steam locomotive practice in this country. It is the hope of the committee that engineers who are devoting their attention to the design of locomotives as a whole and those who are engaged in the development of the various details which have contributed to the high efficiency of the steam locomotive of today will discuss the progress of the recent past and reveal possibilities for future development and improvement in capacity and efficiency.

### TESTS OF THE WEATHERING OF PITTSBURGH COAL

The results of investigations into the weathering of the Pittsburgh coal bed at the experimental mine of the bureau of mines near Bruceton, Pa., are detailed in Bureau of Mines Technical Paper 35, which has recently come from the public printer. The authors, Horace C. Porter and A. C. Fieldner, outline the results of their investigation as follows:

The data obtained show the extent of alteration by weathering in the Pittsburgh coal bed as situated in this particular mine and will serve as a basis for approximate estimates of the alteration of the same bed in other mines similarly situated. The results have demonstrated that indications of weathering such as yellowish coatings of iron hydrate or a dull appearance of the surfaces, do not always signify a material change of the chemical composition or heating value of the coal itself.

The chemical analyses show that changes in composition have occurred in the coal for a distance of about 50 ft. from the outcrop. The analytical data serve as a basis for certain deductions as to the nature of these changes. Several points of similarity become evident between weathered coal of this character and the Cretaceous coals and lignites. On the other hand, certain dissimilar properties of the two render it altogether doubtful whether a true metamorphosis or reversion of the bituminous coal to the lignitic type could ever take place through the agency of weathering. The analyses also show that the composition and heating value of the unweathered coal, computed on the moisture and ash free basis, are fairly constant.

In addition to the usual analyses, special tests were made in order to show the relative oxygen-consuming power of the coal samples and their power of liberating inflammable gases, because these properties are known to vary with the nature of the coal and have a bearing on mining operations. As the direct union of freshly broken coal with oxygen lowers the oxygen content of mine air in places where ventilation is inadequate, and as the continuous escape of inflammable gas from broken coal tends to increase the danger of explosions, it is of interest to determine to what extent this behavior of coal is affected by proximity to the outcrop and consequent weathering.

Samples were taken at different points in the mine and put in 5 gal. glass bottles, the coal being crushed so as to pass a 1/2 in. screen; 20 lb. was placed in each bottle as quickly as possible after the coal had been broken down and the bottle was sealed before it left the mine. By admitting air to the bottles in measured quantities daily and drawing off the air and gases the progress of oxidation of the coal and of the liberation of inflammable gas was followed. The samples thus tested were taken at 5 ft., 50 ft. and 620 ft. from the outcrop.

# CAR DEPARTMENT

## EUROPEAN VESTIBULE CONNECTIONS

For the purpose of providing a closed passageway between coaches, folding bellows extensions are in common use in Europe. These have inherent defects which tend toward high first cost and cost of maintenance. The uneven surface offers many opportunities for the deposit of coal, snow, etc., and the

binding on coupling apparatus and other parts of the car. Moreover, if this type of extension becomes wet and is later folded it has no opportunity to dry, with the result that the material and the seams soon wear out.

A type of connection or "binding cover" which has not these disadvantages has recently been devised and placed in service. This is shown in the illustrations and consists of three metal

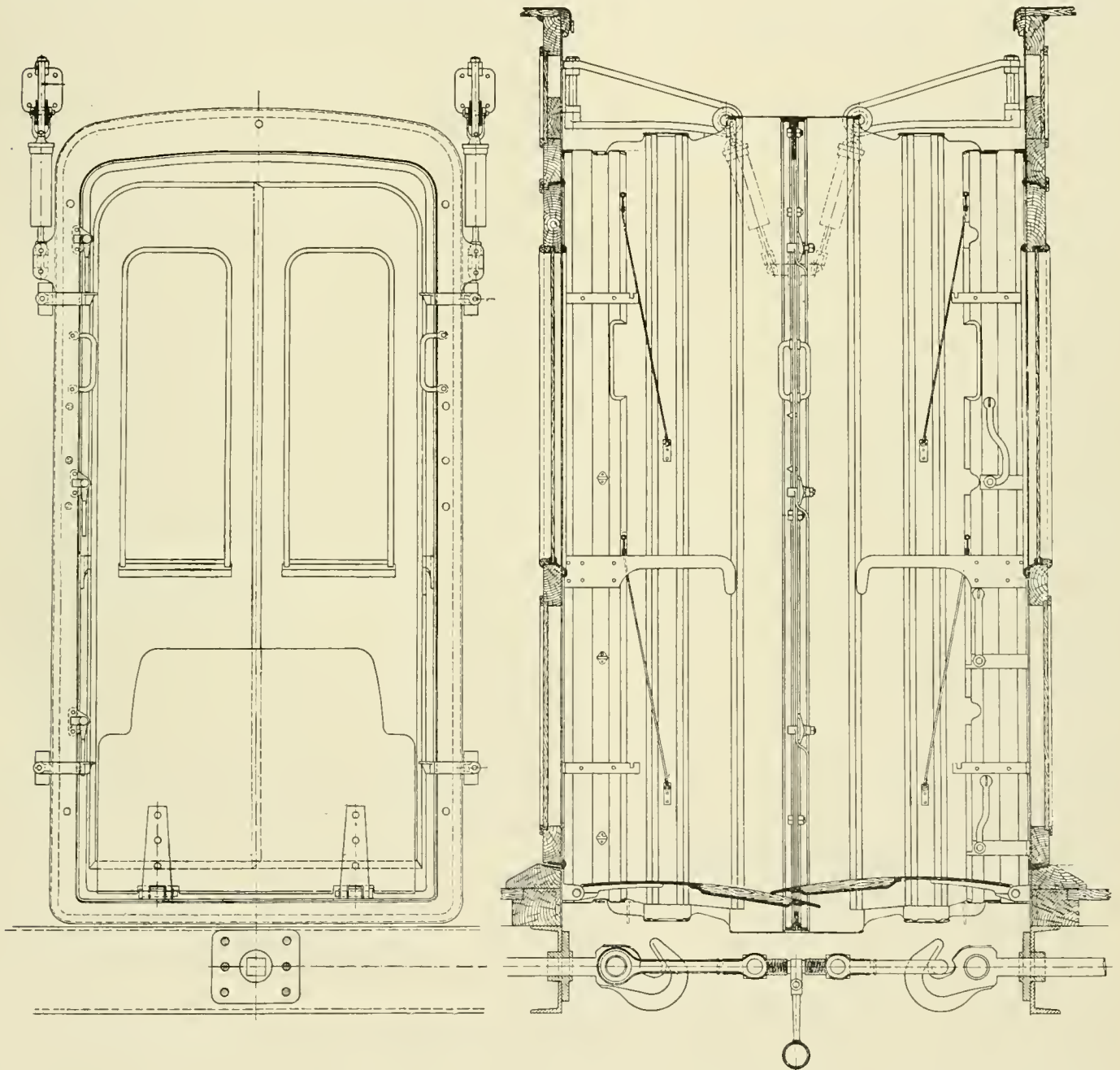

End and Side Elevations of the New Connecting Passage for Coaches

collection of such substances in the spaces at the top often makes it very difficult to close the extension, this sometimes being impossible. Sparks become embedded in the folds and are likely to cause fires and the construction of the arrangement also is such that considerable wear takes place by its rub-

bing on coupling apparatus and other parts of the car. The first of these frames, which is of wrought iron, is attached to the end of the car and attached to it is a flexible connection, the top part of which is of leather and the sides and bottom of canvas. To this is attached a frame of hard aluminum and another flexible



connection is placed between this aluminum frame and the outer frame, which is of iron. [Evidently aluminum is used for the middle frame in order to make it as light as possible as because of its position it cannot be provided with such substantial support as the other two frames.]

Cars equipped with this connection can be used in the same train with those equipped with the old bellows extension and the old and new types are shown connected in one of the illustrations. The outer or coupling frame in the new apparatus is hung on movable pulleys and springs, as is customary in the other type. The middle frame is supported by the two flexible connections, and it is also connected to the inner frame by chains or cables. The three frames are made of such sizes that

walls of the flexible cover open slits are provided which allow water to trickle down along the side walls and through which refuse can be removed from the floor of the vestibule. The parts of the extension are so fastened to the car that they do not come in contact with the couplings and conduits and damage from rubbing on these parts is therefore prevented. When closed the flexible parts lie loosely in a hollow space to which air has access so that when folded they are removed from the effects of the weather and can easily dry.

It will be seen that the only parts of this type of connection which are subject to wear are the flexible connections between the metal frames while in the folding bellows extension all parts of the device receive practically the same amount of wear

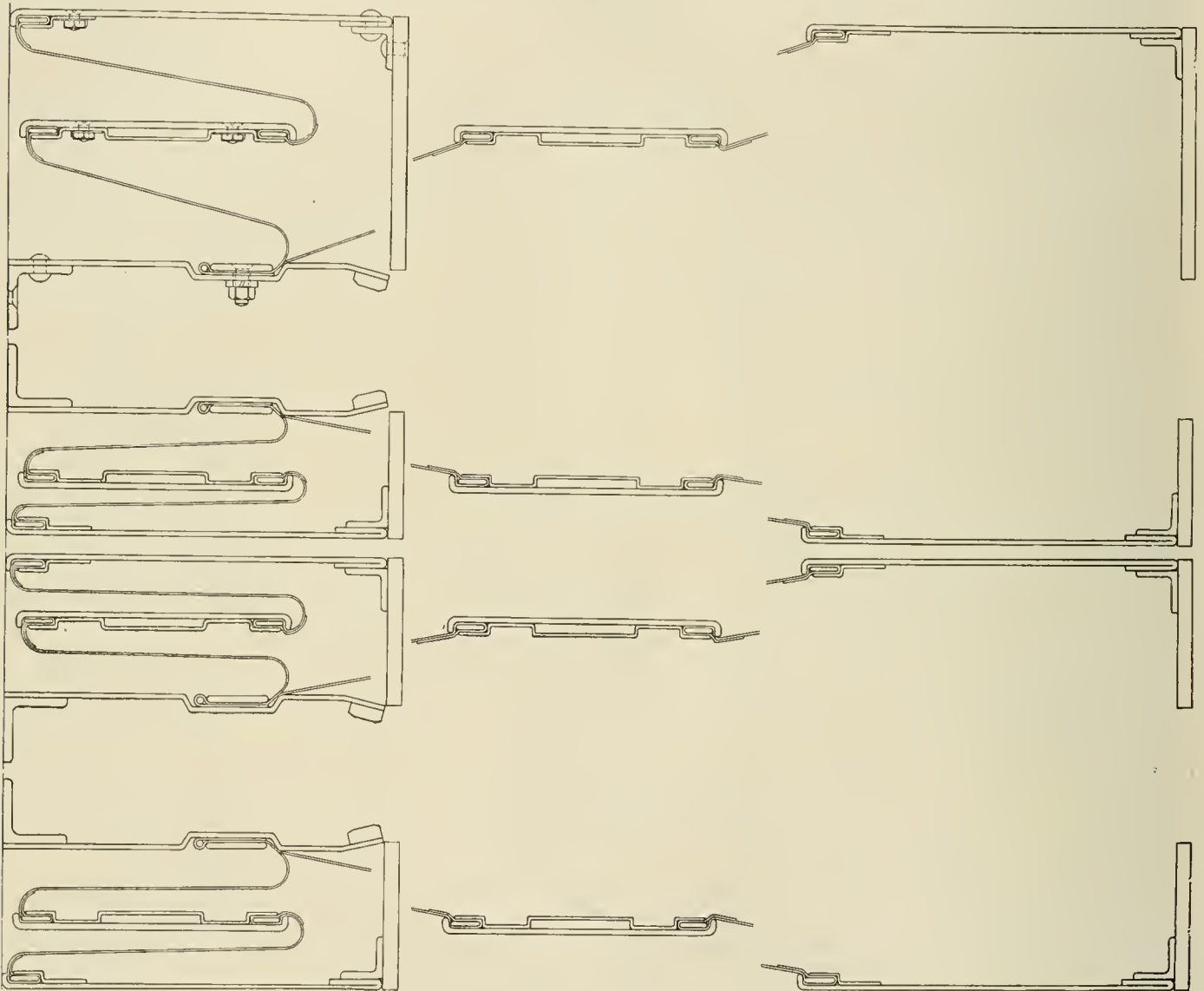

Vertical (Upper Half) and Horizontal (Lower Half) Sections Through the Binding Cover in Closed and Open Positions; In the Latter the Flexible Connections Are Shown Broken Away, the Relative and Not the Actual Positions of the Three Metal Frames Being Shown

they can be pushed one within the other, so that the two flexible connections collapse and the entire structure is enclosed. In making the fastenings between the rigid frames and the flexible connections the edges of the latter are bound round a metal stiffener and then screwed or riveted to the metal frame.

The exterior surface presented is sufficiently smooth, so that there is little likelihood of soot, etc., adhering to it; but because of the tendency of cinders and snow to collect on the top of the structure the spaces between the iron frames are made as large as possible at that point. Between the floor and the side

and tear. It is therefore claimed that the new arrangement requires very little heavy repair work, and such repairs as are necessary are cheaper and more easily made than those on the older type.

The Swiss Railway Alliance has two cars equipped with these binding covers, and they have met with marked success in express trains operating over considerable distances where it was necessary to make frequent changes, necessitating the coupling and uncoupling of cars. The experience gained in this service led to several improvements, particularly along the lines of

providing for the quick renewal of the flexible connections when this becomes necessary. During the most severe cold of the winter of 1913 no trouble was experienced from freezing, and the connections were easily movable at all times. It is expected

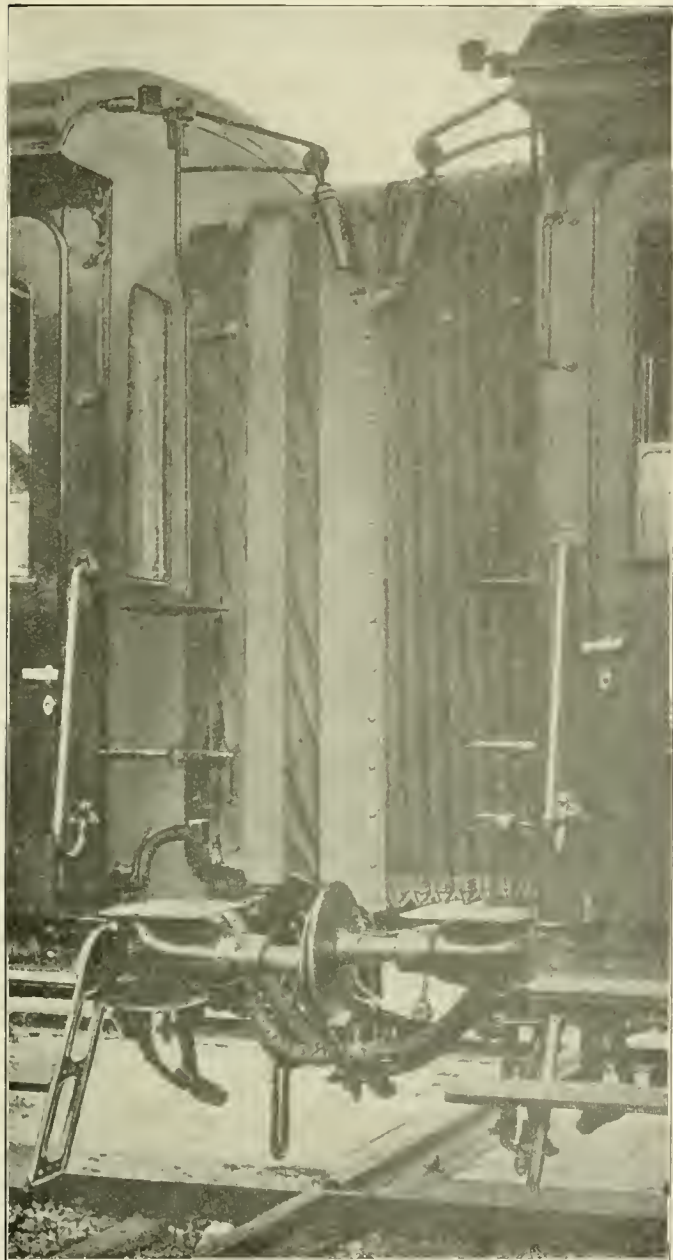

The Car on the Left Has the New Type of Connection; That on the Right the Old Extending Bellows Type

that this type of vestibule connection will be placed in general use in passenger service.—*Organ für die Fortschritte des Eisenbahnwesens in technischer Beziehung.*

**VANADIUM STEEL FOR BLOW PIPES.**—An interesting characteristic of chrome vanadium steel has been demonstrated by tests made on blow pipes used by lamp blowers. The pipes used in the manufacture of incandescent lamps have been soft steel or Norway iron because such material is easy to weld and does not readily oxidize. But the hot glass clings to soft steel or iron so tenaciously that the pipe has to be hammered to remove it, thus requiring frequent repairs. This is not true of chrome vanadium steel; the glass cracks off freely and consequently repairs to pipes of this material are much less frequently required than to pipes made of iron or soft steel.—*Machinery.*

## RESULT OF M. C. B. LETTER BALLOT

The Master Car Builders' Association has issued circular No. 7 which gives the result of the letter ballot on subjects considered at the 1914 annual convention of the association. A total of 101 subjects was voted on, with as many as 2,150 votes being cast on some of the subjects. The following is the result of the letter ballot:

*Standard and Recommended Practice.*—Eleven subjects were considered in this report. The elimination of the skeleton wedges and the change in the coupler yoke, as suggested in the committee's report, were adopted. The location of the signal lamp socket and the marking of freight equipment cars, however, were rejected. The 6 in. by 11 in. journal box lid key was adopted as recommended practice, and the following subjects were advanced from recommended practice to standard: 6 in. by 11 in. journal box and details, 6 in. by 11 in. journal bearings, wedge gage and dust guards; end for a hopper door operating shaft; brake cylinders and triple valves for cars built after January 1, 1915; location of bolting lugs of air brake hose; hose labels; and dimensions for steel and steel tired wheels.

*Train Brake and Signal Equipment.*—The design of conductor's valve, the method of cording and the number to install, together with the color and material of the cord for the conductor's valve and signal valve were rejected. The revision of the air brake and train air signal instructions and the elimination of questions and answers regarding air brakes were adopted.

*Brake Shoe and Brake Beam Equipment.*—The revision of the specifications for tests on No. 2 brake beams, as presented by this committee, was rejected. The question as to whether the No. 2 brake beam should be adopted as recommended practice was also rejected by a large vote.

*Car Wheels.*—Every subject referred to the association for letter ballot in this report was adopted. They are as follows: Change in the wheel defect and worn coupler gage, change in specifications for thermal tests for cast iron wheels, change in the method of marking wheels, change in the title of M. C. B. sheet *M*, change in specifications for branding solid wrought-steel wheels, diameters for steel tired wheels, diameters for wheel centers, method of mounting tires, and the maximum and minimum flange thickness gages.

*Car Trucks.*—A number of subjects was voted on under this committee report. The limiting dimensions for cast steel truck sides were adopted, but the specifications and the variation in weight of truck sides were rejected. The recommendations of the committee for the rejection of truck sides and for the gages for cast steel truck sides were adopted. The designs submitted for 80,000-lb., 100,000-lb. and 140,000-lb. cast steel and pressed steel bolsters were all rejected, as were the specifications for the cast steel bolsters. The gages for the truck bolsters, together with the side bearing clearance of new cars, was adopted, but the spread of the side bearings was rejected. The construction of center plates for standard freight cars, as suggested for the different capacity cars, was rejected, as were the gages for center plates and a suggestion for the elimination of safety hangers. The recommendations concerning truck springs, however, were adopted.

*Train Lighting.*—Under this report the pulley seat for tapered or straight axles, the use of safety hangers for battery box trays and the change in shape of the electric light bulbs were adopted, but the dimensions given for battery boxes were rejected.

*Tank Cars.*—The suggestions made by this committee were all adopted and consist of an addition to the general requirements of tank car specifications, a revision of sections five and seven in the specifications, and the addition to them of section eight.

*Specifications and Tests for Materials.*—All the specifications submitted by this committee were adopted except one. Those adopted consisted of specifications for air brake and signal hose, welded pipe, heat treated knuckle pins, steel axles, refined



wrought iron bars, helical springs, and chains. The specifications for air brake and signal hose and steel axles were advanced to standards of the association. The specification for journal box brasses was rejected.

*Car Construction*—Under this report the minimum requirements in the center sill design for new cars, the design and strength of ends for new box cars, and the placing of placard boards on box cars were adopted, but the specifications for car doors and the suggestions of the committee concerning draft gears were rejected.

*Loading Rules*.—All the changes in the loading rules were adopted.

The reports of the committees which were voted on in this letter ballot were published in the *Daily Railway Age Gazette* of June 11, 12 and 13, 1914.

## SAFETY APPLIANCE STANDARDS\*

BY R. M. BERG

Inspector of Contract Work, Lake Shore & Michigan Southern, East Rochester, N. Y.

It will be my endeavor in what follows to bring before you the reasons for the passing of the Safety Appliance Act, as they have come to me in looking over government reports and to recall to you in a way, why safety appliances have become standardized.

In the early stages of railroading, the equipment of the different roads was but a matter of conjecture to the heads of those roads, and interchanging of equipment with that of another road was not thought of. The necessity of standard equipment, as well as rates, was not felt; but as the commercial possibilities grew it became necessary to bring this equipment and the rates to a standard, so that delay in the transporting of commodities would be eliminated and the public given better and more evenly rated service. Having grown from a private business to one of national scope, the railroad affected the people more directly than before as it became a necessity. This brought about federal action and the Interstate Commerce Commission was appointed to regulate commerce and that which appertains to it.

Freight equipment was being damaged, the lading lost or demolished and the numerous accidents caused the Interstate Commerce Commission to co-operate with the more aggressive roads, and in 1895 the standard height of draw bars was decided upon after consulting with the American Railway Association. In 1898 it became necessary to have all trains engaged in Interstate Commerce equipped with 50 per cent automatic brakes, amended in 1910 to read at least 85 per cent. Along with this came the automatic couplers, and as a matter of safety, grab irons or hand holds were required to be securely fastened to the ends and sides of cars.

The rapidly increasing business was so great and accidents occurred with such rapidity on account of the inefficient appliances provided to protect the employee, that the commission had to again assert itself and co-operate with the employee as well as the employer, and established in 1911 a set of dimensions and clearances for freight equipment that would govern all common carriers engaged in interstate traffic. In compiling this code, it was apparently their idea to employ only such appliances as would be of need to protect the life and limb of the employee and yet not necessitate an unnecessary expenditure of money on the part of the company.

While I am not an authority as to the exact reasons given for each dimension and clearance, deduction points towards a few of them as given below; these may appear very plain and apparent reasons, but it is just my intention to recall these to your mind.

"Hand-brakes shall be of an efficient design and work in harmony with the power brake." Should they not work in harmony a separate set of brakes would be necessary.

"The brake shaft should not be less than  $1\frac{1}{4}$  in. in diameter." This was found to be the smallest practical diameter to withstand the maximum power in setting the brakes, with a small allowance for safety. Welds, on account of the uncertainty of true welding, were impractical.

A 15-in. brake wheel was found to be of such size as to provide sufficient leverage to set the brake with the strength of an average man. Any material other than malleable iron, wrought iron or steel, would either not be of sufficient strength or would not be economical.

The brake shaft is located in such a position that it will not interfere with the efficiency of either the running boards or end ladder.

A 4 in. clearance around the brake wheel is allowed as being a minimum space wherein a man can effectively operate the brake with safety.

The brake shaft step, gooseneck or stirrup, as it may be colloquially termed, being of U shape, provides the greatest degree of efficiency while setting the brake, as it guards against the tangling up of the brake chain.

The square fit at the top of the brake shaft gives better results by not permitting the brake wheel an undesired amount of freedom as is often found the case with a round fit. The taper of 2 in 12 is in common use in mechanical work.

Running boards are given a width that will allow a man to walk on them without the necessity of stepping off when he becomes momentarily unbalanced by the motion of the car. The latitudinal one is wider, as it is placed near the end of the car and where one may become more affected by the height; also to cover extreme widths allowed for locations of the ladder on the side of the car.

The 19 in. spacing of ladder rounds is the average height of a man's foot from the floor when his knee forms a right angle.

The 16 in. length of tread is long enough to conveniently place both feet on the ladder round without interference or extra precaution.

The 8 in. spacing from the end or side of the car to the inside of the ladder is a maximum distance in which a man can conveniently reach around from one to the other without stretching.

The end and side ladder rounds coinciding produce safety on account of the dependability upon where one is to step when he passes from one to the other.

A 2 in. clearance is given because the length from the middle of the second phalanx of the middle finger of a man's hand is approximately  $1\frac{1}{2}$  to  $1\frac{3}{4}$  in. The other quarter inch is allowed as a margin of safety; also it allows a depth great enough to secure a foot hold.

The end clearance of 12 in. allows a minimum space of 24 in. for a man to utilize to work in or in climbing an end ladder between two cars, should he be forced to go between them. This is the minimum space used by a man of average size.

Roof hand holds are spaced between 8 and 15 in., on account of the average length of a man's forearm with fist doubled up being 15 in.; 8 in. allows a more convenient distance with a location such as to secure a safe application.

The location of side and upper end hand holds is such that it is in a line parallel to a man's head, a convenient distance for a man to reach without losing his bearing. The lower end hand holds are located in such a position as to be easily accessible should a man be forced to use them while between cars. The additional end hand hold used with the outside end sill is located at such a height as to be convenient in passing between two coupled cars.

I have found it a matter of great convenience when studying this act to think of these deductions with the figures themselves, as they provide a better basis upon which to work.

\*From a paper read at the meeting of the Niagara Frontier Car Men's Association, Buffalo, N. Y., September 23, 1914.

# STEEL CABOOSE FOR THE PENNSYLVANIA

An Eight-Wheel Car, 29 Ft. Long and Weighing 38,000 lb.; Design Has Not Yet Been Standardized

The Pennsylvania Railroad has recently designed and built at Altoona an all-steel cabin car or caboose designated as class N-5. This car has not been made standard, but is a tentative design and will be thoroughly tried out on different parts of the road before a decision is made as to its suitability. The severe conditions to which the car will be subjected made it necessary that the construction be as strong as that of heavy steel freight cars, and very careful consideration has been given to each feature of the design, including those which tend to add to the comfort and convenience of the trainmen.

So far as can be learned, this is the first all-steel caboose ever built, the inside lining, the flooring through the passageway, the platform floor and the window sash being the only parts for which wood is used. The car weighs 38,000 lb. and is 31 ft. long from face to face of drawheads, 14 ft. 9½ in. high over the cupola

diaphragms ⅜ in. thick are located 3 ft. 7 13/16 in. on either side of the center line of the cupola, which is 12½ in. off the center line of the car, and are riveted to the center and side sills. The usual body bolster has been eliminated and the body side bearings are supported by steel cantilever castings, which are riveted to the center sills and to a ½ in. tie plate, which extends across the bottom of the center sills and outward to the ends of the side bearing castings.

The side sill, or side floor supporting member, is a 4 in. by 4 in. by ¾ in. angle, with the back turned outward. This angle is continuous between the side and end sill connecting castings, which form the side supports of the platforms and connect the side sills, the diagonal braces and the end sills, and are shaped at the outer ends to form corner push-hole pockets. The diagonal braces are of U-shaped section, 6 in. wide and ⅜ in. thick,



First All-Steel Caboose Built for Service on the Pennsylvania

lamp, and 10 ft. 2½ in. wide over handholds. There is a 30 in. platform on each end, with a 1¾ in. floor and side box steps. Ratchet hand brakes are used.

## UNDERFRAME

The center sill construction of the underframe is similar to that used on the Pennsylvania's steel freight cars, being composed of two 10 in. 25-lb. channels, a 21 in. by ½ in. cover plate riveted the full length of the center sills, and a 4 in. by 4 in. by ¾ in. angle riveted to the bottom of each channel on the inside, and extending continuously between back draft lugs, the total area being 36 sq. in. This construction is reinforced by a striking plate at each end, a center plate reinforcing casting above the center plate, and pressed steel spreaders between the diaphragms. The front and back draft lugs are cast integral with the striking plate and the center plate reinforcing castings. Two dished

with 3 in. flanges turned downward. They are flattened out at either end and riveted to the top flange of the center sills and the side and end sill connection.

The end sill is also a pressed U-shaped section, which is fastened to the striking plate and the side and end sill connecting casting. The entire underframe, with the exception of the platform, is covered with ¼ in. steel plate, which extends from the center sill cover plate to the side sill angle. The brake rigging supports and the equipment box, which is 4 ft. long, 23 in. deep, and 21⅞ in. high, are secured to this floor sheet. The equipment box is made of ⅝ in. sheets, with a door at the front which swings down.

## SUPERSTRUCTURE

There are no posts used in the superstructure, the transverse stiffness being obtained through the end construction and bulk-



heads, which form the sides of the lockers at the center of the car. These bulkheads are so located that they are directly above and riveted to the diaphragms of the underframe, thus forming four stiffeners at the center of the car each 3 ft. deep. The sides

At the corners, the side and end sheets are connected by a 3/16 in. cover plate, which acts as a corner post. The end construction is of the same general design, the sheets being fastened to the underframe by a 2 in. by 2 in. by 1/4 in. angle, as well as riveted

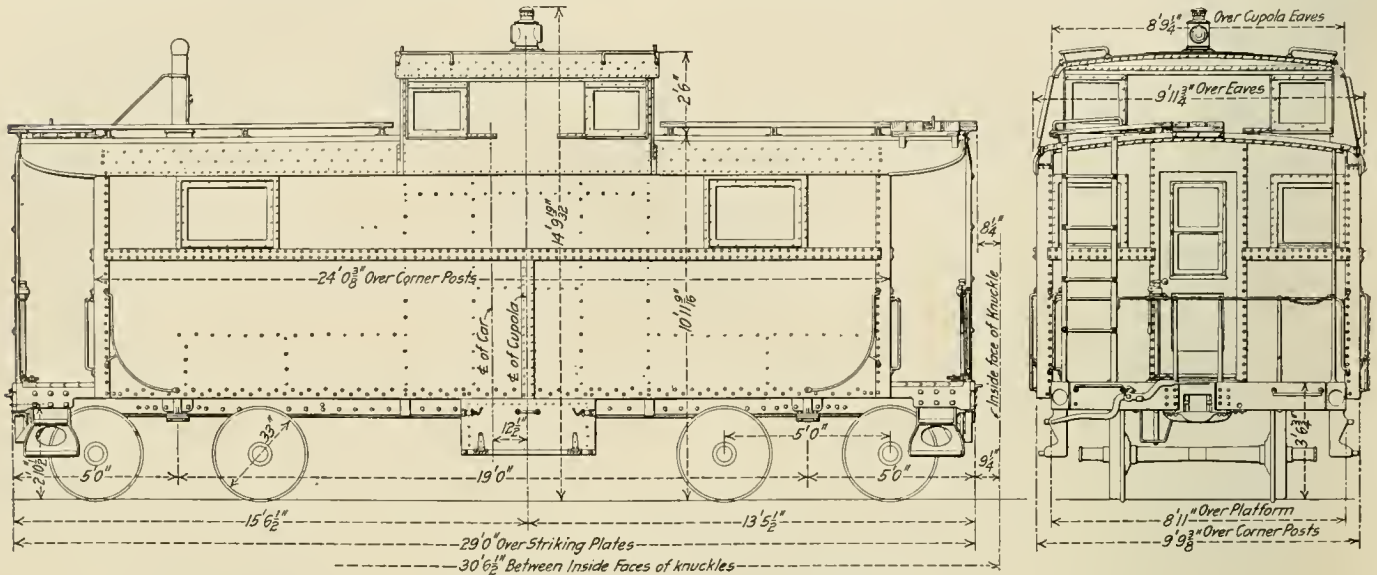

Elevations of the Pennsylvania Steel Caboose

and ends of the car are made up of 1/8 in. sheets and a 4 in. by 1/2 in. belt rail. The bottom panel is composed of two sheets, joined on the center line of the cupola by a butt strip, and butting

beneath the corner cover plate, the belt rail and the end door frame. The end is further supported by two 4 in. channels, which act as door posts. These channels are fastened at the bottom to

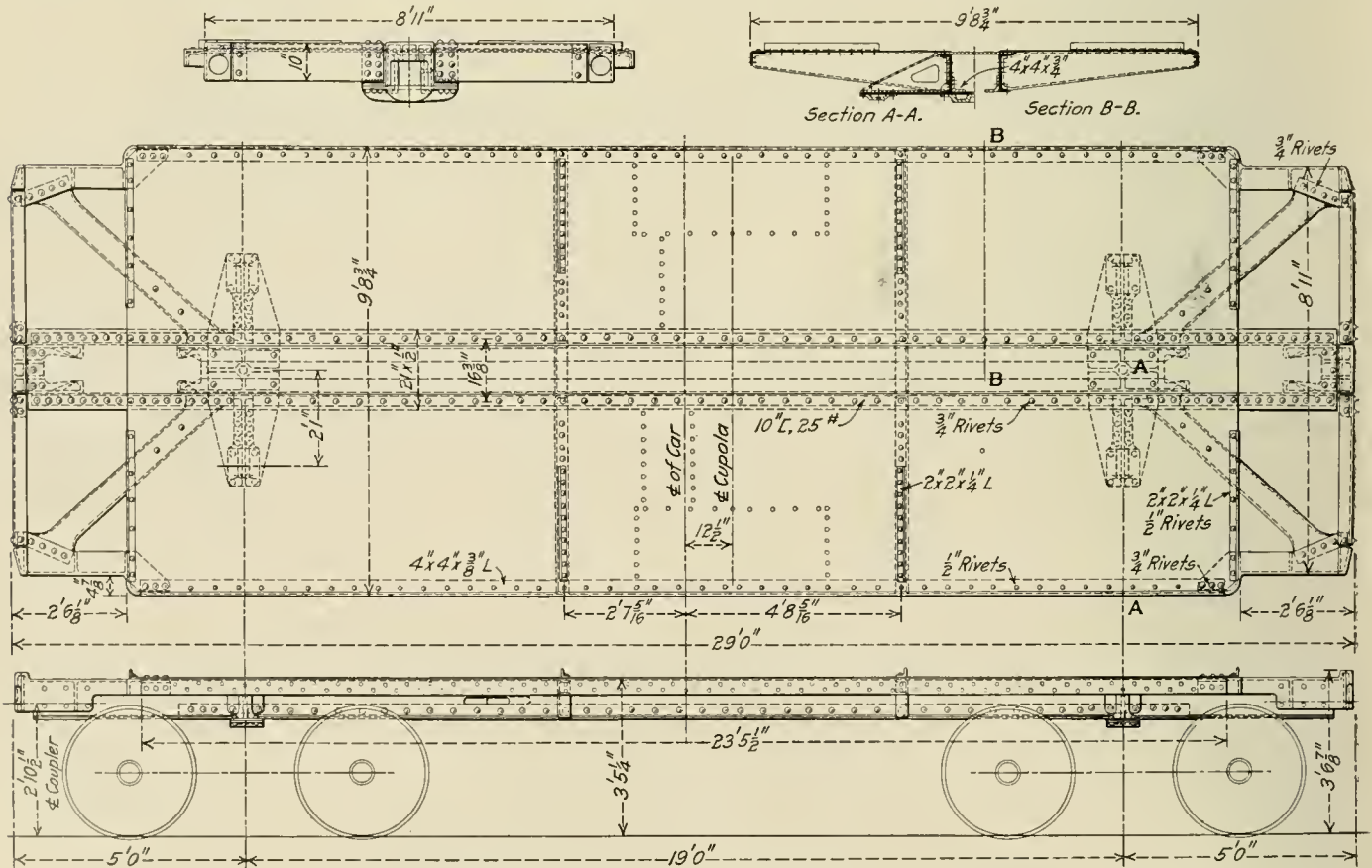

Underframe Construction Used on the Pennsylvania Steel Caboose

against the top side sheets beneath the belt rail, which is 4 ft. 2 in. from the bottom of the side sill angle. The top panel is composed of three sheets, which are connected by the window frames.

a cast steel threshold plate and the underframe, while at the top they are secured to the roof sheets. On the inside of the belt rail, and at the eaves, extending from

end sheet to bulkhead, is a U-shaped section, which stiffens the sides of the car at these points and also provides a means of securing nailing strips for the support of the lining.

The side window frames, which are riveted to the outside of

rail being incorporated with the eaves, while the window sill forms the bottom guide. This construction is such that when the window is pushed up against the end projection strip it forms a weathertight construction. The object in placing the

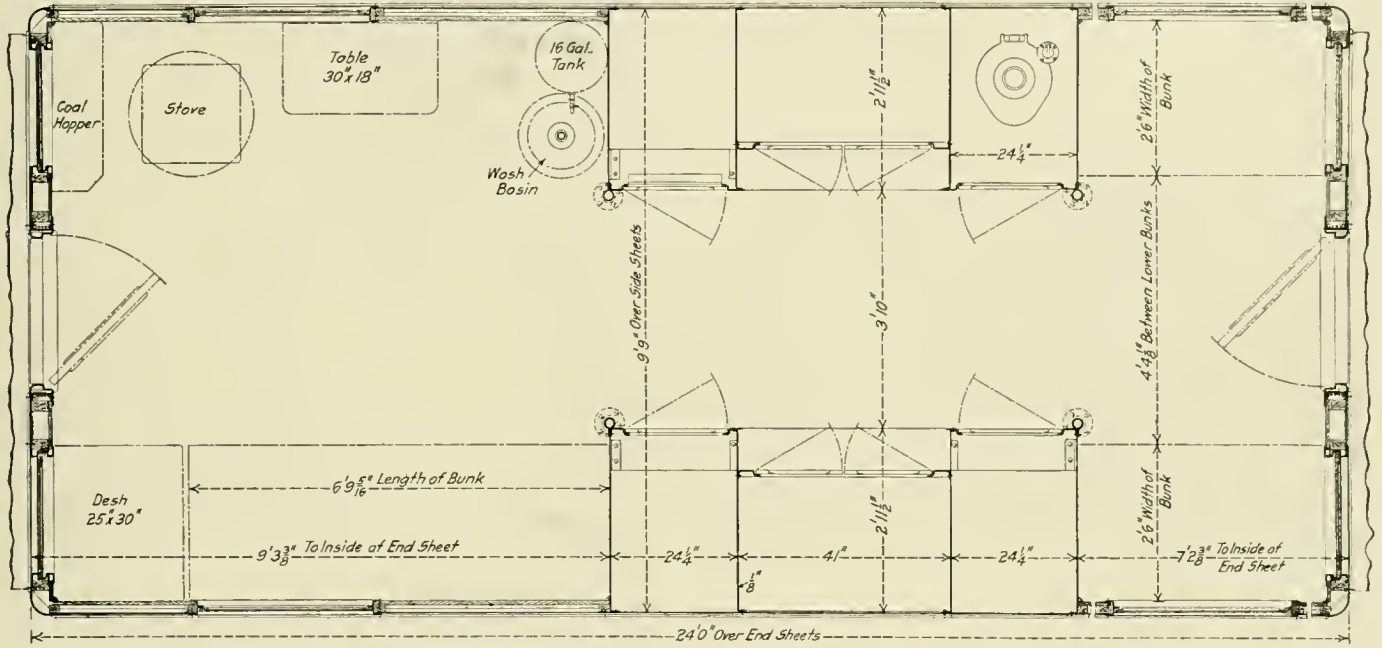

Floor Plan Showing the Location of the Different Interior Fittings

the side sheets, are 3/16 in. thick. A 1/2 in. by 3/16 in. filler extends along the top of the side sheets, between the window frames, so that it is possible to extend them up under the roof sheets, making the construction waterproof and at the same time forming a straight surface to which the roof sheets can be attached.

windows outside is to leave the interior smooth. The sides of the cupola are inclined towards the center line of the car to allow for tunnel clearance.

ROOF

The roof sheets, which are 3/32 in. thick, extend lengthwise of

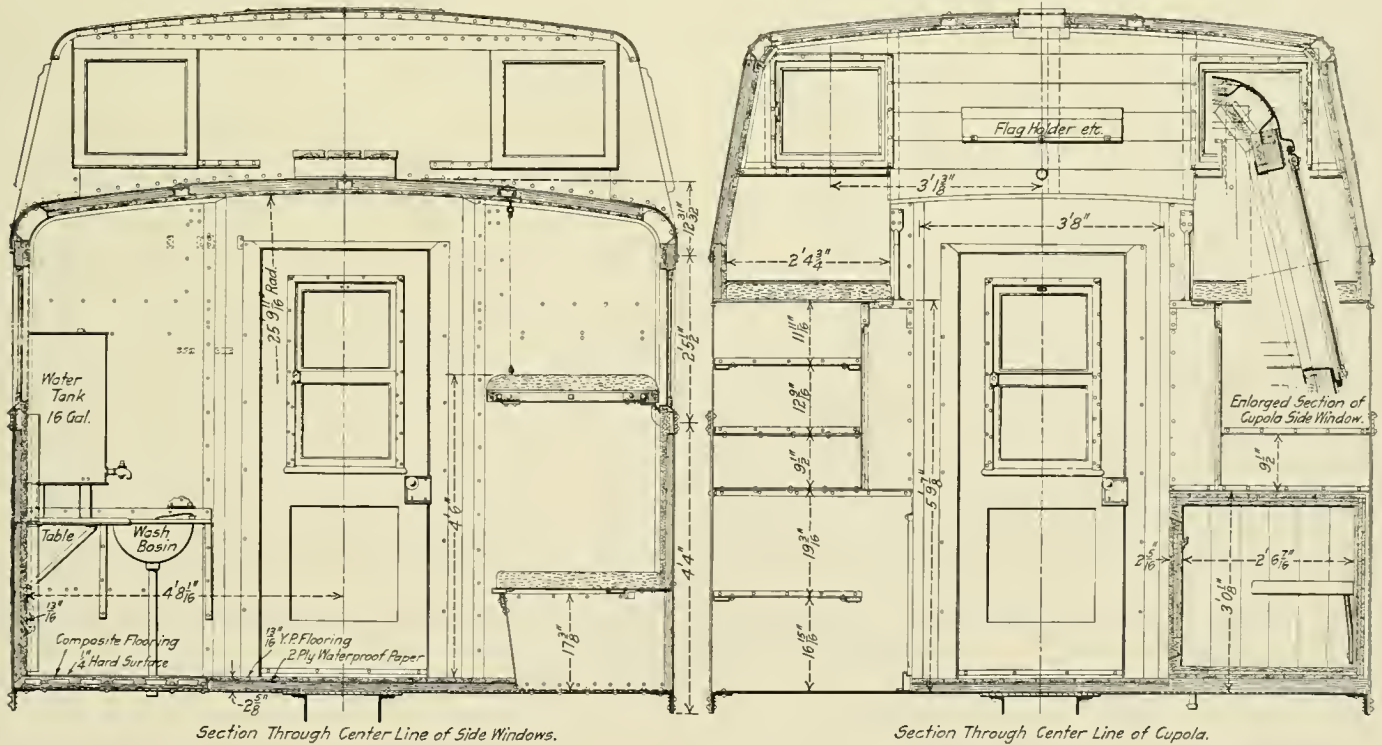

Cross Sections Through the Pennsylvania Caboose

The cupola extends 2 ft. 6 in. above the body of the car and is of the same general type of construction. The side and end windows of the cupola are all hung on the outside, a top guide

the car in three panels, two of which, forming side panels, extend down over the sides of the car and fasten to the side sheets and eaves; a central panel, which overlaps the two side panels,



is secured with  $\frac{1}{4}$  in. rivets spaced  $1\frac{1}{2}$  in. apart. Tar paper is placed between the lap of the center and side sheets, to insure a watertight joint. The main roof is supported by U-shaped purlins, which extend from the end sheets of the car to the cupola end sheets. The cupola roof is of the same construction. These purlins answer the double purpose of supporting the roof and providing a means of securing nailing strips for the ceiling.

The main roof extends over the platform  $2\text{ ft. }2\frac{1}{2}\text{ in.}$ , and has a 2 in. by 2 in. by  $\frac{1}{4}$  in. angle extending around the edge, which

stove end and two at the opposite end. The lower bunks are of a box type, 6 ft. 10 in. long and 2 ft. 5 in. wide, and are arranged for the storing of equipment necessary to the car in the bottom.

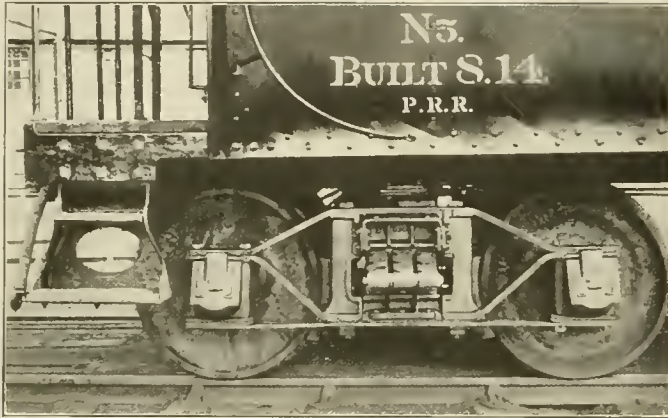

Platform Arrangement and Truck of the Pennsylvania Steel Caboose



Interior of the Pennsylvania Caboose

lends stiffness to the structure and also acts as a weather strip for leading the water away from above the platform.

INTERIOR ARRANGEMENT

Convenience, comfort and safety were given great consideration in fitting up the inside. The car is equipped with a stove for heating and cooking purposes, a drop table, water cooler, washstand,

The upper bunks, which are of the same dimensions, are attached to the belt rail by means of a cast steel hinge bracket, and when

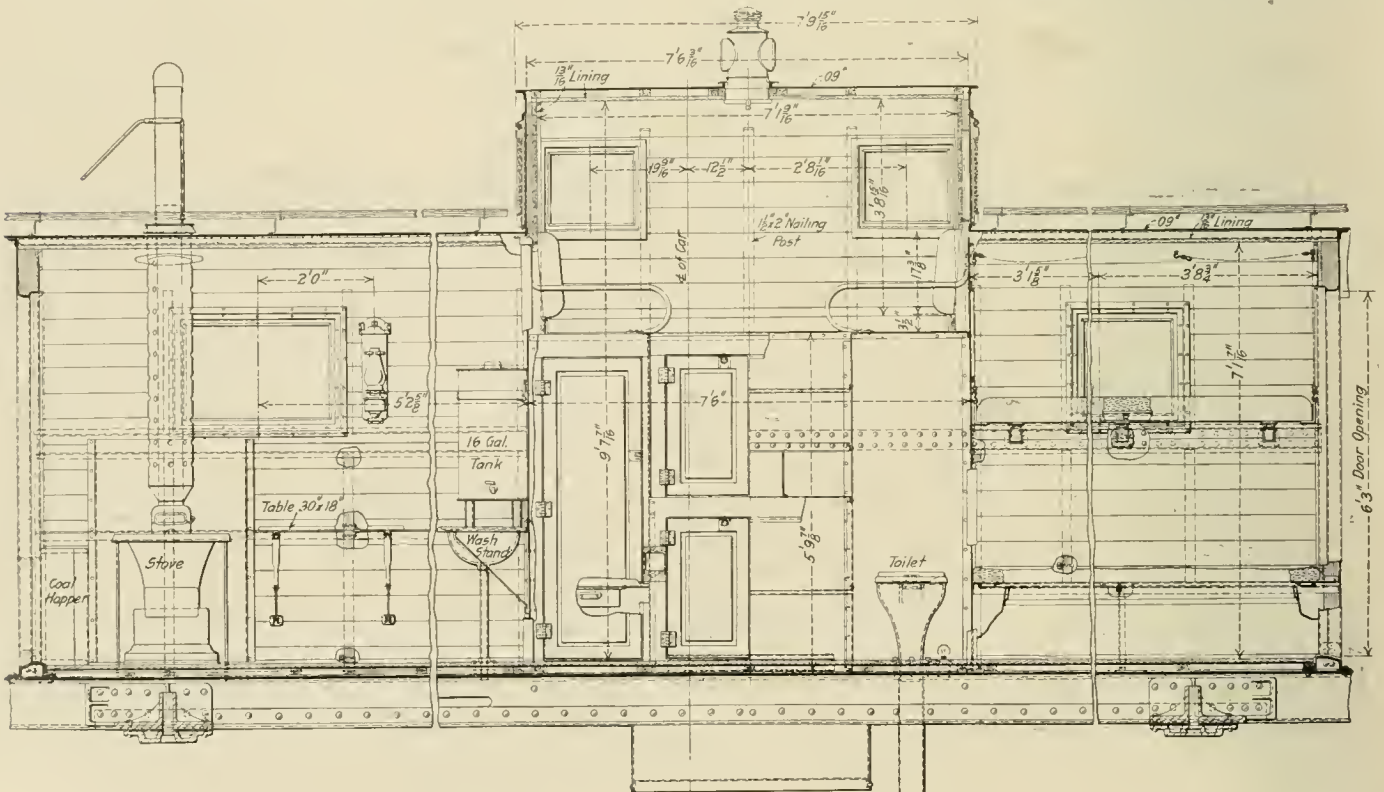

Longitudinal Section Showing Arrangement of One Side of the Caboose

refrigerator, desk and hopper, as well as lockers, drawers and cupboards for the men's personal belongings. Three pairs of bunks, upper and lower, are located along the sides, one at the

not required may be lowered and used as a back for the lower bunk when used as a seat. The upper bunks, when raised, are held in position by chains secured to the roof purlins, and hooked

to the side of the bunk frame, which is composed of 1¾ in. by 1¾ in. by ¼ in. angles, to which wooden nailing strips are secured for tacking down the canvas top. Including cupola seats, the car has sleeping facilities for eight men, the cupola seats being the same width and length as the bunks.

The lockers, which are located between the bulkheads and the lower cupola seats, contain the refrigerator in the lower center section, on the side opposite the stove and the hopper in one of the end lockers on the other side. The arrangement is such that there is ample room for dishes, food, lamps, oil and waste. All locker doors, drawers, shelves, etc., are 1/16 in. thick.

The side and end windows are above the belt rail, so that the light is not cut off when the upper bunk is raised. The side windows are fixed, while those at the end, including the end door windows, may be dropped. All locks or catches, with the exception of the refrigerator door lock, are flush, thus eliminating pro-

## WOODEN CARS IN FREIGHT TRAINS\*

BY G. E. SMART

Master Car Builder, Intercolonial Railway, Moncton, N. B.

A few years ago the 30-ton all-wood freight car was considered standard, but since the introduction of steel in car building it has replaced wood and today we have all-steel coal cars, all-steel box cars lined with wood, and steel underframe cars of all classes of 40 and 50 tons, and a few even of 75 tons capacity. There are, however, a large number of wooden underframe cars still in service, and the question is, what can be done to make this class of car safe to be handled in long trains and meet the severe usage that they receive in yard switching?

The draft gear problem is certainly the most important. The annual cost of repairs to cars that are damaged through draft gear failures, and loss and damage claims resulting therefrom

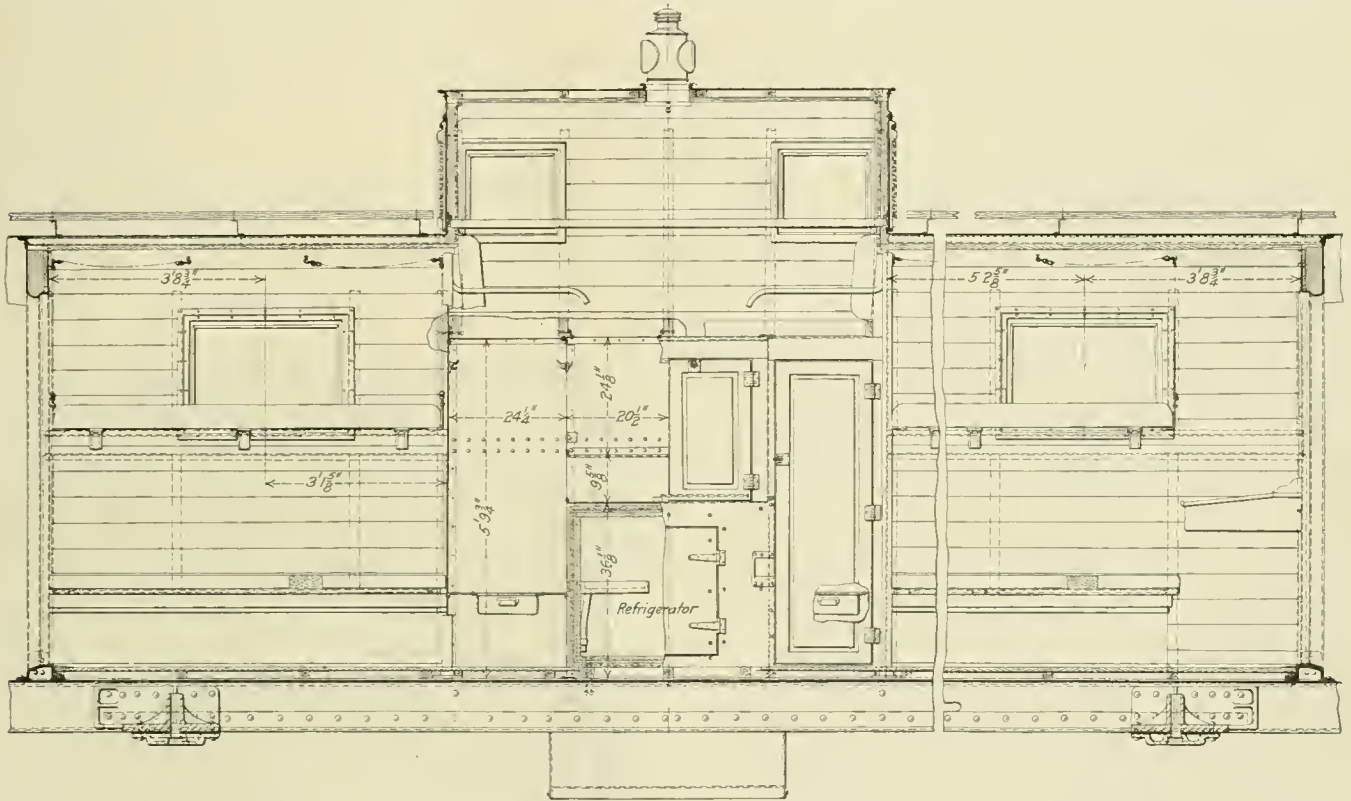

Longitudinal Section Showing Arrangement of One Side of the Caboose

jections against which a man might be thrown by a sudden lurch of the car. The cupola is also equipped with a safety rail, extending between the end sheets of the cupola on the center line of the car, which is of convenience as a handhold.

### TRUCKS

The car is equipped with specially designed arch bar trucks of 5 ft. wheelbase, having axles with 3¾ in. by 7 in. journals. The usual column castings are replaced by a malleable casting which serves as a column casting, brake hanger support, spring seat, and spring plank extension. The bolster is of the inverted U-shaped type, with malleable iron stiffening castings, spring seats and bolster guides. The springs are full elliptical, 34 in. long and there are three in each group. The spring plank is U-shaped, ¾ in. thick and 8 in. wide, with 1½ in. vertical legs turned upward. It extends across the truck 4¾ in. beyond the center line of the arch bars, and is flattened at either end and bolted to the bolster guide spring seat and brake hanger support.

**BATTLESHIP BOILERS.**—The boilers of the battleship Nevada, just launched are to carry 295 lb. gage pressure. Oil-fired Yarrow type boilers will be used.—*Power.*

exceed the cost of all other repairs made to freight car equipment. What are the causes of these failures?

First, the introduction of heavier power and longer trains; second, the placing of light and heavy cars together in trains; third, rough switching of cars in yards.

With regard to the first and second causes, the tractive effort of locomotives has increased during the last few years from 20,000 lb. to about 45,000 lb. for locomotives in general use in Canada, and in the 2-10-2 type used on United States roads to 84,000 lb. In addition, there are in use in certain sections of the country, locomotives of the Mallet type, with a tractive effort of 110,000 to 120,000 lb. The average number of cars hauled in a train a few years ago was 25, the train being approximately 1,000 ft. long. Today ordinary trains are composed of 60 to 100 cars, and a train of 100 cars would be approximately 4,000 ft., or about three-fourths of a mile long. What chance has a wood frame car under the conditions as they exist today on the front end of such a train? If a car of this type were to be traced from the time it leaves the terminal it would be found that it was necessary to remove parts of the load quite often,

\*From a paper read before the Canadian Railway Club, Montreal, Que., October 13, 1914.



which, beside the expense of repairs results in delay to freight en route, and is the cause of many damage claims.

The solution of the problem does not lie altogether in the physical characteristics of the car or entirely in the mechanical department. The operating officers should co-operate with the mechanical department in reducing the freight car repairs by arranging as far as possible that cars with all-steel construction or with steel underframes, or those with steel center sills be placed in the front end of the trains. It is a fact that we find light capacity cars with wooden underframes or empty flat cars leaving the terminal on the head end of long trains, and in the majority of cases the cars are billed through and will not be set off between terminal points, unless set off on account of draft gear failure. This could be avoided if the cars were placed towards the rear of the train before leaving the terminal. There are railways which recognize the necessity of placing weak cars toward the rear of the train, and they provide cards stating that they must not be placed more than 15 cars from the caboose. This indicates that the car is in such a condition that it must be so located in the train, but is safe in ordinary service to be hauled to destination. If this is done delay and extra switching on account of draft gear failures would be eliminated, and it would not be necessary to move the lading.

The third cause, "Rough switching in yards" is a great factor in car repairs. There is no speed limit for switching in yards, nor are there any rules in force governing the speed of locomotives in switching service. If one were to confer with the car inspectors and obtain their opinion as to where most damage is done to cars, I think I am safe in saying that their answer would be in the switching yards, as their daily experience in inspecting cars immediately on arrival and after they have been switched in the yard will confirm this. This is only a small item as compared with actual damage started in the yard, which, through the cars being necessarily weakened thereby, is aggravated after leaving the terminal and results in many cases in the cars breaking down before reaching destination. A visit to a freight car yard will show that it is just a question of how fast the cars can be switched together, the speed that the cars are traveling is not considered, hence cars are found buckled up in yards and the draft gear pulled out and lying around.

There should be some speed limit in yards to prevent this destruction of equipment. The time lost in switching out bad order cars damaged in the yard and in taking them to the repair track would often offset the time gained by excessive speed used in switching. The cost of repairing these cars must also be considered, and the thousands of dollars of damage done to the contents of cars that are not set out for repairs.

What is the mechanical department doing today to overcome these troubles?

First, they are building steel frame cars to certain specifications with stronger types of draft gear.

Second, applying steel underframes or steel center sills and steel ends.

Third, applying steel draft arms to the wood center sills.

Fourth, applying heavier types of couplers and draft gear, and using friction draft gear.

The demands of modern railroading require the stopping of a high speed train in about two minutes and the draft gear is expected to absorb the shock. The air brake department can help to eliminate the strain on the draft gear by instructing the enginemen as to the proper method of handling the long trains. The principal thing is to control the slack to prevent it from running in or out harshly. Slack in draft gear cannot be prevented, as it is due to compression of the springs, and the heavier the locomotive and the longer the train, the greater the care that is required. Enginemen are instructed in the air brake instruction car how this should be done, but the general air brake inspector should see to it that the rules are followed out in actual service.

The vital question today before the car department is how

to keep these wooden underframe cars in service. The majority of the railroads are destroying the 40,000-lb. cars, but the 60,000-lb. and 80,000-lb. cars that were built with wooden underframes and short draft timbers are not any stronger and cannot withstand the heavy service and severe yard conditions of today. Unless the operating department will assist in reducing the damage done to cars and thus reduce freight car repairs, and also keep the cars in service by marshalling this class of car on the rear end of the train, and exercising greater care in switching cars in the yard, the cost of freight car repairs will increase and the repair tracks will be full of bad order cars. The only other remedy is to spend money to apply steel center sills or steel draft arms, so arranged as to strengthen the present wooden center sills, and in addition to this reinforce the end of this class of cars. But the strongest car built cannot withstand the severe usage received in yard switching operations today.

## ROCK ISLAND LUNCH COUNTER CAR

The accompanying photograph shows the interior arrangement at one end of a new combination lunch counter and dining car, just put into service by the Rock Island Lines on the "Californian" train, to operate between Dalhart, Tex., and Santa Rosa, N. M. One-half of the car is devoted to a lunch counter, with a seating capacity of 12. The chairs are stationary, revolving, and furnished with high backs, and the car is equipped to handle all orders quickly. The remainder of the car is devoted to the regulation dining car service, there



Interior of the Rock Island Lunch Counter Car

being six tables, three on one side, each with a seating capacity of four persons, and three on the other side, each with a seating capacity of two persons.

The car has been rebuilt at the Rock Island shops for the purpose of providing a service suitable to the conditions prevailing through the territory in which it will operate, where it is necessary to maintain a fast schedule and where eating houses are comparatively few. Dining facilities on this train are imperative, but the demand for ordinary dining car service is so limited that the service is expensive to maintain.

# SHOP PRACTICE

## AUTOGENOUS WELDING

The following is taken from a report presented by C. L. Dickert, assistant master mechanic, Central of Georgia, at the convention of the International Railway General Foremen's Association, held in Chicago, July 14-17:

We have the electric and oxy-acetylene plants installed at Macon shops. One of our greatest troubles is breaking in operators and holding them on the job after they have learned to handle the torch successfully. Each craft does the welding of metals that originate in their respective departments. A blacksmith of the right caliber would, in my opinion, be the right man to handle the welding, as he has the knowledge of heating metals, taking care of expansion and contraction, whether or not the metal is overheated, etc.

*Electric Welding.*—A field in which electric welding has proven very successful and profitable is that of welding flues to the back flue sheets. We have in service today over 90 locomotives with flues welded to the back flue sheet, making a total of about 27,000 flues, and we have our first engine to fail on

manner, viz.: Copper ferrules, roll, bead and prosser. A heavy bead is built up in welding the flues to the flue sheet. This leaves a rough finish. Some roads shape up the beads with a cutter, while others go over them with a beading tool to smooth them over. We find this is not necessary. The time welding 2 in. flues will average 14 per hour. In a few instances the operators have welded as high as 21 flues per hour.

Where welded flues are to be removed it only requires a few hours longer to cut off the beads. We found that flue sheet is in better condition than before welding in the flues, as the welding builds up the sheet around the flue holes to about the original thickness. We have a tool for facing off the rough surface after the flues are removed, making a good, clean sheet for applying new flues.

Welding in half side sheets and patches, repairing mud rings, etc., have proven very successful and profitable with the electric process, which will be seen from the following comparison between the old method of rivets and patch bolts.

A crack  $3\frac{1}{2}$  in. long developed in the mud ring corner, and was electric welded at a cost of \$1.18. The old method of patching would have cost about \$15, and engine would have been held out of service for at least three days. Two half side sheets welded in, 20 ft. of welding. Time 26 hours. Labor cost \$10.37. Old method about \$42. Two half side sheets and half door sheet, 26 ft. welding. Labor \$13.90, old method about \$61.50.

On new smoke box and extension front ends all butt joints are welded, saving about \$3 on each job over the old way of straps and rivets. Quite a lot of welding with the electric outfit is being done on tank work. Corners are cut out and patches welded in, reinforcing the same as on boiler work, and we have no further trouble with leaks. Patches, half side sheets, half door sheets, and in fact all boiler plate work, in preparing for welding, are beveled to 45 deg., the two inner edges coming together, and sheets securely fastened with temporary bolts. A ripper  $\frac{3}{16}$  in. thick is run through, making a  $\frac{3}{16}$  in. opening on the inner side. The operator, when welding, welds from 3 to 4 inches flush with the sheet, and then goes back and reinforces the weld to about 60 per cent of thickness of plate. See Fig. 1.

Cracks in the side sheets that extend from one staybolt to another, are V'd out the same as preparing a patch, and the staybolts are removed and the holes welded up. Unless the rivets are loose to begin with, it is not necessary to remove them as they do not loosen up from welding.

While the electric welding of cast iron as a general proposition has not proven satisfactory, especially on parts that are under strain, we are successfully welding up cracks in smoke box doors and fronts.

Electric welding has proven very valuable and profitable to us in filling up worn links, link blocks, blade jaws, saddle pockets and cellar bolt holes in driving boxes; welding new notches in quadrants, worn places in frames caused by spring rigging wearing; building up piston fits to crossheads, rod ends and straps; in fact everything that is worn or broken that it is possible to reclaim at a profit. There is no limit to its usefulness, as we always find something new to be done.

*Oxy-acetylene Welding.*—Oxy-acetylene process of welding and cutting has passed the experimental stage, and has made a more rapid growth in the past few years in railroad work than all the preceding years combined. The Central of Georgia Shop at Macon is now being equipped with a strictly up-to-date plant, which is being installed by the Oxweld Railroad Service Company. The generator house, which is located a short distance from the main shop, consists of three rooms. In the first room

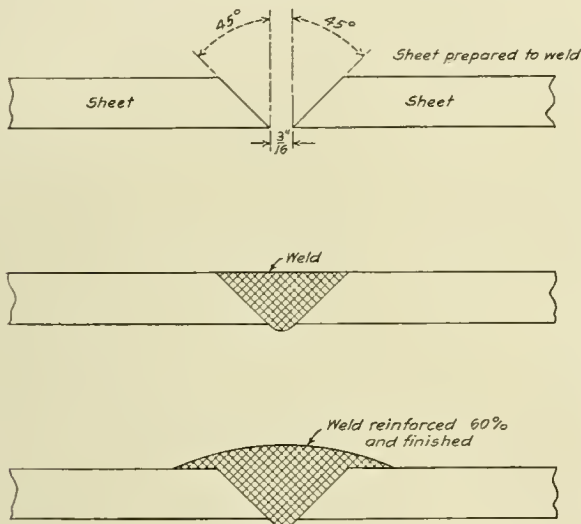

Fig. 1—Method of Welding Boiler Sheets by Electric Process

line of road with flues. We have, however, had some few flues to leak after being in service a short while, which was due to bad beads on the flues when they were welded in. If part of the bead is off, exposing the copper, it is very difficult to get a good weld.

Our first experiment on flue welding was tried out on an engine that was shopped for a new back flue sheet. The sheet was so badly worn and buckled that it was impossible to keep the flues tight. The flue beads and sheet were thoroughly cleaned with a sand blast, given a light working, and the flues were welded in. This engine was put back in service June 1, 1913, and to date has given no trouble from leaking. During this time a hydrostatic test was applied, and no leaks developed. This job was done at a cost of \$14.68, where new flue sheet would have cost about \$150, and the engine would have been held out of service for at least thirty days.

It is an easy matter to get the full life required by law out of a set of welded flues, thereby increasing the flue mileage, reducing the cost of maintenance, eliminating overtime in the roundhouse and on the line, and at the same time reducing the flue forces in the shop.

When new flues are to be welded, we apply them in the usual



we have a 400-lb. total capacity generator. In the next room we have a twenty cylinder manifold, and the next room is used for supplies. The generator is duplex, having two generators—one on each side of a gas bell. In this way there is never any delay in charging the generator. The manifold works on the same principle, having ten 250 cu. ft. cylinders cut into line at a time.

The two gases are piped through the erecting, boiler and tank shops, stations being located at most convenient places to reach the work. In the erecting shop we have stations between every other pit, making it possible to reach any part of an engine

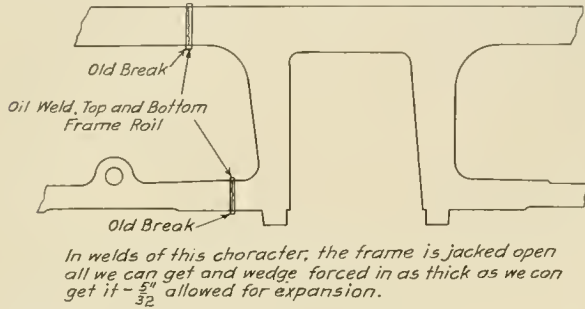

Fig. 2—Difficult Oil Weld, Top and Bottom Frame Rails

with a short length of hose. The stations through the boiler and tank shops have the same spacing.

We are installing the low pressure system, which means an acetylene pressure of less than one pound per square inch. The constant pressure obtained in the low pressure system is an assurance of a neutral cone on the blow pipes. The oxygen line carries 40 lb. pressure in the pipes, with proper adjustments at the blow pipe. The acetylene valve on blow pipe is opened wide, leaving only the oxygen valve to be adjusted.

Oxy-acetylene welding and cutting is indispensable in a railroad shop. In cutting it has the field to itself. The cutting, alone, is a paying proposition, saying nothing of its many advantages in welding over other methods. Our practice in removing fireboxes is to cut the fireboxes up into sections with the oxy-acetylene gas, and punch the sheets out. The average time in

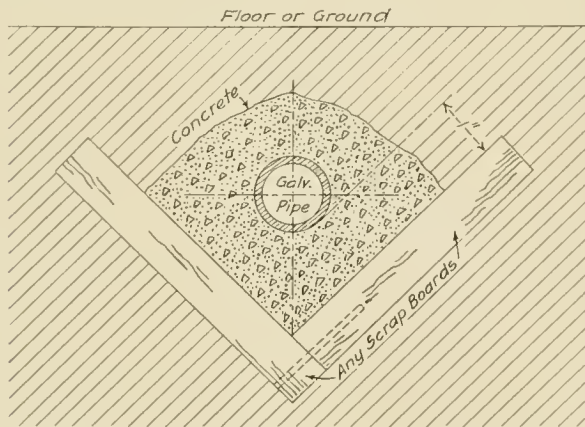

Fig. 3—Method of Laying Pipe for Oxy-Acetylene Systems

cutting out a firebox in this manner is five hours, thereby saving the breaking of the staybolts and radials. Following are some of the most important jobs that we have done in boiler department, and the life and results from the oxy-acetylene welding:

Half side sheets and half door sheet welded in a firebox May 15, 1912. No trouble, still good.

Half door sheet welded in, June 28, 1912. No trouble, still good.

Half door sheet and patch in side sheet, welded January 18, 1912. Patch in side sheet failed March 10, 1913.

Four patches welded in outside firebox sheets where spring gib wore holes in boiler, October 31, 1912. These patches are still good. Never gave any trouble.

Half door sheet, extending 8 in. on each side sheet, welded in, November 25, 1911. Still good, no trouble.

Half side sheet 10 ft. 4 in. long, welded in, November 4, 1912. About 2 in. of this weld gave way. Trouble stopped by caulking.

Half side sheets and half door sheet welded in the firebox, February 27, 1912. The weld on right side sheet failed May 6, 1912, had to be patched. Balance of job—good.

Patches at front mud ring corners welded in, December 24, 1912. No trouble, still good.

New collar welded in two-thirds of fire door hole, November 12, 1912. No trouble, still good.

Half door sheet welded in, May 26, 1913. No trouble, still good.

Two cracks welded in top knuckle of back flue sheet flange, September 30, 1911. Weld held until firebox was removed in November, 1913.

Two patches welded on bottom corners of back head, March, 1913. Patch failed on right side in August, 1913. Repeated attempts were made to weld this by electric process but failed, and finally had to resort to patch bolt patch.

The cutting torch is used very extensively in the boiler department. All patches, all side sheets, all fire boxes, and all holes in

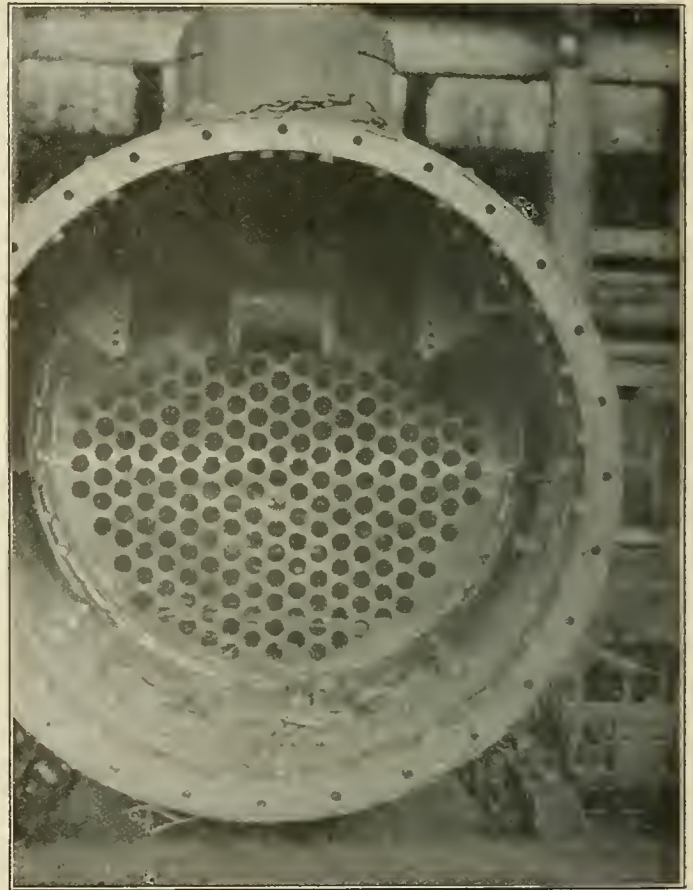

Fig. 4—Front Tube Sheet Repaired by the Oxy-Acetylene Process

the cab, cab and running boards, are cut with the oxy-acetylene torch.

**Thermit Welding.**—The welds we have made with thermit have proved very satisfactory. Have quite a number of frames welded that have been in service several years. Some few welds failed in service, the percentage of failures being very low.

**Oil Welding.**—Oil welding of locomotive frames has been the practice at the Macon shops for the past two years. Quite a number of welds have been made during this time which have proven very successful. The success of oil welding, like all other methods of frame welding, depends largely on allowances made for expansion and contraction. The most difficult job we have found is shown in Fig. 2 where top and bottom rails are broken. We have made two welds of this nature, one of which failed and the other still in service.

There is but little expense attached to this method of welding.

The outfit consists of small oil burner, oil tank and two small battering rams. The entire outfit is mounted on four wheel truck which is easily handled around the shop. The material used, crude oil, fire brick and fire clay, costs about \$2. The balance of the expense is labor, which amounts to about \$6, making a total cost for preparing and welding frames, an average of \$8. In preparing a frame for welding we cut out straight through the frame where it is broken, with the acetylene torch, trimming off afterwards with a hammer and chisel to get rid of the scale and burnt metal made with the torch. The frame is then jacked apart and good hammered iron inserted, leaving projection of 1/2 in. all around. A furnace is built around the frame with fire brick, leaving an opening for the burner which

broken castings, iron, steel, brass, aluminum, etc., the oxy-acetylene process is used. With thermit perfect welds on locomotive frames in almost all localities have been made. The average cost for making thermit welds is from \$15 to \$20, not including the removal or application of parts necessary to make the weld.

The cutting torch is used for a variety of operations. The welding torch is used to repair broken cylinders, all kinds of boiler work, broken steam and exhaust pipes, air pump heads, gear wheels, pulleys, built up the inside lap of slide valves, malleable iron parts for cars, parts for air drill, cast steel parts of various shapes, brass parts such as lubricators, brass and aluminum castings, and in fact there are very few parts which are usually found about a railroad shop which cannot be repaired. Autogenous welding has very materially reduced the cost of repairs, and in addition the engines are not kept out of service near so long as they would be had it been necessary to make repairs in the old way. In the boiler shop, alone, the oxy-acetylene process has reduced the labor cost 20 per cent or 25 per cent.

*Welding Practices on the Delaware & Hudson.*—That road is making a very considerable saving with the electric welding, and discontinuing its use would mean the manufacture of a great many new parts that are now built up and reclaimed.

The oxy-acetylene system was installed last year by the Ox-



Fig. 5—Three-Fourths of Door Sheet Removed

is placed within a few inches of the opening. When the frame is brought close to the welding heat, the oil is cut down, allowing the heat to soak thoroughly through frame. The oil is then gradually increased until the frame reaches a welding heat, and the jacks are removed, letting pressure come on the weld before the furnace is knocked down. The furnace is then knocked down, and hammers and battering rams are used for hammering up the dutchman, leaving the frame slightly reinforced. While the heat is on all surplus metal is chipped off.

We have found this method of welding to be the most economical, just as good as any, and better than some methods of heavy frame welding that we tried.

*Welding Practice on the Atlantic Coast Line.*—For all heavy work, such as locomotive frames, thermit is used. For light work, such as boiler and tank sheets, steel car parts, small



Fig. 6—Copper Safe End on Charcoal Iron Tube

weld Railroad Supply Company. The class of work done includes the welding of various castings when defective, building up of the worn surfaces on the heavier castings (as this is a surer process than the electrical) welding of engine frames, which are not always successful, welding engine truck frames and cradles, all frame braces and brackets, plugging holes in heavy motion work parts, reclaiming nearly all tender bolsters, guides and pedestals, cracked locomotive bells, etc. On boiler work all firebox door sheets are welded when they join in the fire door hole, patches to boilers are applied, and sections to flue sheets and broken bridges are welded. In cutting, this system is indispensable. As to cost the total saving shows a considerable balance in favor of autogenous welding.

Some of the features to be guarded against with this system, especially if the shop is piped, are leaky joints in pipes, hose, fittings and connections. Keep the water bottles filled to prevent explosions, instruct the operators as to the use and abuse of torches, and use every means to consume the least gas, all of which rapidly runs up the expense.

The Goldsmith thermit weld system is used for welding nearly all engine frames, this having proved the most desirable. The points to watch to make a successful weld are: Watch and have the surface hard and clean, as slag does not make a good weld. When welding a frame with two rails, that is, a top and bottom section, heat the section which is opposite the break to a red heat before pouring, so as to eliminate the contraction in the welded frame. Enlarge the weld as far as possible to insure strength. This method is used also in welding broken spokes in steel driving wheels. However, it is necessary to return and



shim the rim of wheel due to contraction, unless the entire section is cut out, rim and all, and raised about  $\frac{1}{4}$  in., the amount of the shrinkage on wheels. This pays on wheels with retaining rings.

*Welding Practice on the Chicago, Milwaukee & St. Paul.*—In regard to the welding of locomotive frames at the Dubuque Shops, Iowa, with crude oil: Over 200 welds successful on all parts of frames have been made in the last 5 years. If the frame is broken through the back or the brace, or the leg, the break is drawn together with clamps and the exact length is taken. Then a 2 in. hole is drilled down through the center of the break, and an air power hack saw saws out the broken parts, leaving a straight surface. Then the frame is expanded about  $\frac{7}{8}$  of an inch with screw jacks, and a tin template is made to fit the opening, and a block is machined to the template, making a nice fit. The block is driven to place ready for welding. A furnace is then built allowing  $2\frac{1}{2}$  in. from each side of the block, and  $3\frac{1}{2}$  in. on the top and bottom, and extending out about 13 in. from the frame. The burner is then started, and in about two hours on a section 5 in. x  $6\frac{1}{2}$  in. the frame will be ready to weld, which is done by dropping out the jack, allowing the pressure to come forward and make a perfect butt weld. The burner is quickly removed, and small battering rams are used to weld up the sides. If the frame should not come to the desired length a heavy battering ram is used, and with a few blows the frame is brought to the proper length.

One of the particular points in the frame welding is to be sure to get the grain of iron placed the proper way in the frame. Also the average cost in welding these frames is about \$7.50 for blacksmith work and \$8 for machinist's work, making a total of \$15.50.

*Conclusions.*—Experience now indicates that the two methods, electric and oxy-acetylene welding, have advantages over each other in certain different operations. For welding flues to back flue sheet, filling in on caulking edges, reinforcing small corroded parts, or where it is important to confine the high temperature to as small an area as possible, due to contraction, the electric process is superior.

For large boiler patch work, new half or whole side sheets, long cracks, or in work where suitable provision for contraction can be readily provided, and in cutting or removing defective parts on old sheets, the oxy-acetylene excels. It is therefore clear that in large shops the installation and use of both methods is not only desirable, but an excellent paying proposition.

When the oxy-acetylene system is used precautions should be taken when pipe mains, valves, and fittings are first installed. An excellent method is to use galvanized pipe with all screwed connections soldered over, and leak gaskets at all flanged connections, after which the pipe mains are encased in concrete with small expense as outlined on Fig. 3. All valves should be lead seat and tipped which can be applied to ordinary globe valves.

The use of the apparatus and particularly the torch, requires, like everything else, some intelligence and experience to obtain the best results. The most important feature the operator must learn is to so manipulate his work as to avoid as far as possible excessive contraction of cooling parts. Welding of long vertical cracks or seams of firebox sheets can be nicely provided for by a small running stream of cold water each side of crack while the welding is in operation and the heating of sheets thereby confined to a very small space. Horizontal seams and cracks in fire boxes are best made before mud ring rivets are driven. In the application of firebox patches suitable provision for the contraction of cooling parts can be frequently provided by slightly dishing or cupping the new patch to be applied which is afterwards pulled in straight by nut and bolt before staybolts are applied.

In repairs to fire door cracks, experience strongly indicates, for back shop practice at least, better results are obtained by cutting out the cracks, replacing by patches. The welding in by oxy-acetylene of new full, or half side sheets, or strips from 12 in. to 24 in. high all round the bottom of throat sheet, outside sheets

or wrapper sheets, and back head is a most decided success from many standpoints, including a first class permanent tight job, great economy of both labor and material as well as the saving of time over the old methods.

The Atlantic Coast Line has experienced most excellent success with boiler repairs made by the oxy-acetylene process at their Waycross, Ga., shops, including some very radical departures over the old method of repairs. Fig. 4 shows repairs to front flue sheet completed except reaming out flue holes where bridges were welded. Fig. 5 shows an engine after three-fourths of the fire door sheet has been removed for renewing. The portion of the old sheet removed was defective at the flanges where it was secured to the side sheets, along mud ring, and fire door cracks. It will be noted the good part of this fire door sheet where secured to crown sheet is retained.

Fig. 6 shows a copper safe end welded onto a charcoal iron flue which comprised one of a full set of flues so installed experimentally September, 1913, in a locomotive type of stationary boiler that previously had given a great amount of trouble due to pitting

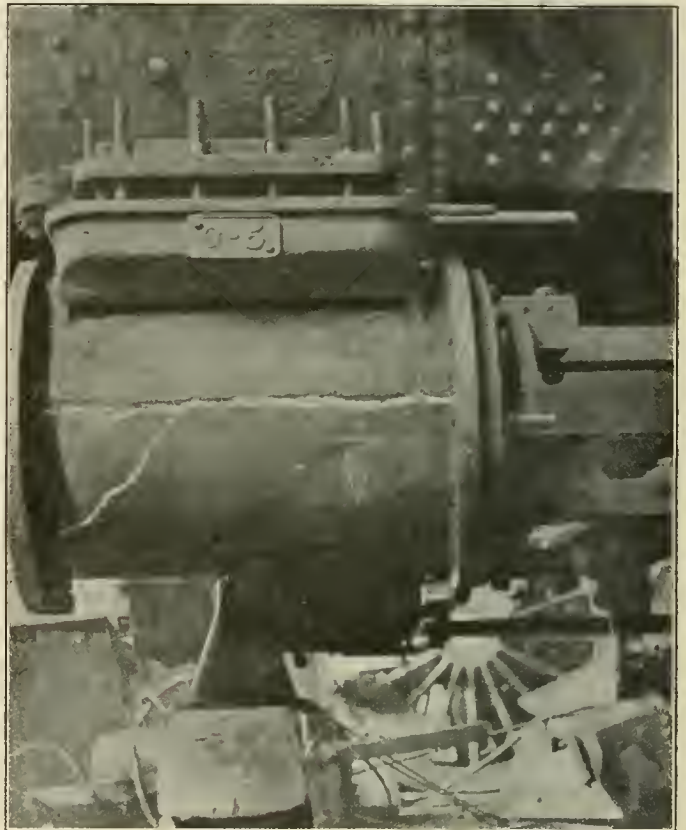

Fig. 7—Cracked Cylinder Repaired by an Oxy-Acetylene Weld

of flues just inside of back flue sheet. The trouble previously experienced has been completely eliminated, and boiler still in the same continual service without flue repairs. It is worthy of mention, that of this set of flues when applied to boiler, not one failure occurred from leak in weld during test or since, which proves the adaptability of oxy-acetylene welding of dissimilar metals. Fig. 7 shows a cylinder repaired by the oxy-acetylene process.

The thermit process of welding as applied to the railroad repair shop, particularly in its field of frame welding, maintains its advantage in the element of time, portableness in manipulation, simplicity of apparatus required and its convenience to the smaller outlying points of modern facilities. In the back shop after the engine is stripped, ordinary frame fractures are thermit welded in four and one half to six hours from start to pour. Special railroad thermit is now obtained already mixed with the proper proportions of one per cent nickel, one per cent pure metallic man-

ganese, and fifteen per cent low carbon boiler punchings, thus relieving the shop entirely from what previously was one of the most important features for best results.

Unless a very high quality of crude oil is available, kerosene is much more desirable for preheating, since crude oil, particularly of the heavier gravities, leaves a sooty deposit or film of carbon on the heated parts which prevents the hot thermit metal from coming in direct contact with the stock. In order to obtain perfectly sound welds with the thermit process, it is absolutely essential when the pour is made, that the parts to be welded be at least a bright red heat. The preheating should be done inside the mould, and in this way not only the parts to be welded are thoroughly heated, but also the interior of the mould as well.

The report was signed by C. L. Dickert, Chairman, C. of Ga.; R. B. Van Wormer, A. C. L.; C. M. Newman, A. C. L.; A. A. Masters, D. & H.; F. P. Miller, C. M. & St. P., and Wm. Hall, C. & N. W.

DISCUSSION

F. A. Byers, St. Louis & San Francisco, spoke of the splendid success obtained with the oxy-acetylene process at the new shops at Springfield. These shops are piped for oxygen and acetylene gas and equipped with 20 welders. All firebox side sheets are welded, whether quarters or halves are put in. The joints are sanded and chipped and the staybolts and rivets are put in after the weld is made. That road has made successful frame welds by making a double V on the frames and pre-

heating them to above a cherry red. Two men weld at the same time, one on each side. There have only been two failures out of 77 frame welds. They have only been able to find one man who can weld cast iron with oxy-acetylene satisfactorily, making it so that it can be machined. In welding in flues, the sheets are sanded, the flues are rolled slightly and beaded before being welded. As a record, he stated that 360 flues were welded in three days and three nights by one man. As regards the welding of safe ends on flues, the acetylene method has been found more expensive than the other method. When welding in the flues the front ends are left loose, while the back ends are being welded in. In connection with his remarks, Mr. Byers submitted the accompanying table, showing the work done at the new shops of the Frisco during the past fiscal year.

Other members could not report as good success with frame welds with the oxy-acetylene process as did Mr. Byers. This was attributed to the workmanship more than the process. Mr. Lauer, of the Illinois Central at Memphis, spoke of the good results they had with welding cast iron with the oxy-acetylene process. It is necessary to thoroughly heat the object to a cherry red and keep it as near that temperature as possible while the weld is being made. Charcoal is used for the heating fuel and the broken parts are clamped together and V'd out for the weld. After it is welded the cylinder is allowed to cool slowly.

C. L. Dickert, C. of Ga., stated that the electric welding outfit would pay for itself by just welding flues alone. As regards patches, it was believed better to have a circular patch, or one with rounded corners, rather than a rectangular patch. Flat spots have been welded on wheels very satisfactorily by the electric method, Swedish iron being used, and, in some cases, wheel lathe chips for the flux. Worn holes in various parts of locomotives have been built up successfully with both the oxy-acetylene and the electric methods of welding.

As regards thermit welding, very good success was mentioned, the Chicago and North Western at Clinton having made 154 welds with only five failures. Three of the failures were attributed to poor moulds. Other roads reported very good results, and it was stated generally that extreme care must be taken in making the moulds correctly. One member stated that he had successfully welded a frame with two heats, although this was not believed to be good practice.

CONSUMPTION OF OXYGEN AND CARBIDE, FRISCO SHOPS, APRIL 1, 1913, TO JUNE 30, 1914, INCLUSIVE

Month	New shops		All other shops		Total	
	Oxygen Cu. ft.	Carbide Lb.	Oxygen Cu. ft.	Carbide Lb.	Oxygen Cu. ft.	Carbide Lb.
April (1913).....	6,600	550	.....	.....	6,600	550
May .....	12,500	1,100	.....	.....	12,500	1,100
June .....	13,400	1,200	.....	.....	13,400	1,200
July .....	22,400	2,500	.....	.....	22,400	2,500
August .....	26,600	2,500	.....	.....	26,600	2,500
September .....	37,850	5,200	4,700	800	42,550	6,000
October .....	67,550	6,500	10,800	800	78,350	7,300
November .....	57,600	8,100	38,300	5,100	95,900	13,200
December .....	60,000	5,600	53,500	6,955	113,500	12,555
January (1914) ..	60,000	7,600	70,550	8,200	130,550	15,800
February .....	69,000	6,600	70,250	8,500	139,250	15,100
March .....	83,100	14,500	101,650	15,100	184,750	29,600
April .....	106,500	19,000	130,050	22,500	236,550	41,500
May .....	132,100	14,700	163,356	19,750	295,456	34,450
June .....	134,000	16,000	193,214	22,900	327,214	38,900
Total .....	889,200	111,650	836,370	110,605	1,725,560	222,255

SAVINGS BY INDIVIDUAL ITEMS—NUMBER OF PIECES, SPRINGFIELD NEW SHOPS, JULY 1, 1913, TO JUNE 30, 1914.

Parts	Pieces	Other methods	Oxy-Acetylene	Saving
Ashpans .....	637	\$456.44	\$904.34	\$1,384.10
Brackets .....	391	858.22	332.04	466.13
Braces .....	661	2,562.42	1,066.34	1,496.08
Bolsters .....	13	231.57	24.87	206.70
Crossheads and pistons.....	254	3,873.68	572.37	3,301.31
Center castings .....	26	172.44	63.18	109.26
Center plates .....	2	98.50	6.44	92.06
Cylinders .....	23	6,105.88	89.21	1,516.67
Driving boxes .....	240	1,644.21	355.74	1,288.47
Drawbars .....	12	127.08	11.93	115.15
Driving wheels .....	3	133.58	36.13	97.45
Door collars and sheets.....	400	6,974.09	1,955.39	5,018.70
Deck castings .....	1	71.30	3.02	68.28
Equalizers .....	236	735.23	416.65	318.58
Engine frames .....	567	9,172.80	2,316.86	6,855.94
Front end ring .....	45	404.65	140.88	263.77
Firebox work, miscellaneous.....	3,017	20,733.12	10,210.40	10,522.72
Lubricators .....	3	105.00	3.54	101.46
Flue sheets .....	261	3,866.53	1,137.97	2,728.56
Shop machines .....	692	2,891.58	990.39	1,901.19
Main rod brasses .....	8	141.89	10.46	131.43
Miscellaneous repairs .....	473	1,455.36	560.21	895.15
Main rods .....	146	1,184.90	404.99	779.91
Miscellaneous parts .....	4,914	19,640.32	8,865.29	10,775.03
Oil boxes .....	531	1,790.64	678.95	1,011.69
Pedestals .....	626	2,080.05	742.78	1,337.27
Reverse lever strips.....	368	989.01	471.70	517.31
Rocker arms .....	100	788.53	181.24	607.29
Running boards .....	374	770.61	383.02	407.59
Steam chests .....	5	45.99	22.37	23.52
Steam pumps .....	10	190.00	19.95	170.05
Side sheets .....	495	31,512.10	3,918.31	27,593.69
Steam pipes .....	62	249.11	102.96	146.15
Truck boxes .....	113	437.71	201.51	236.20
Truck frames .....	14	531.58	65.80	465.78
Triple valves .....	2	23.00	2.48	20.52
Water columns .....	4	151.00	30.71	120.29
Total .....		\$120,532.12	\$37,340.42	\$83,191.60

BLUEPRINT MARKING FLUID.—A useful and absolutely permanent marking fluid for writing in white on blueprints, may be made by taking a little soda ash and making a saturated water solution. This may be done as follows: Take a small bottle and nearly fill it with water; then add the soda ash, shaking the bottle from time to time, until the water will not dissolve any more of the crystals. Next strain the solution to remove the undissolved crystals and any dirt which may be present, and then pour it back into the bottle ready for use. This may be kept indefinitely. This solution may be applied to the blueprint with either a drawing pen or an ordinary writing pen. It works equally well in either case. Where the liquid is applied it bleaches the blue color of the print and leaves it a clear white. It sometimes happens that if the solution has been made too strong, a white powder forms on the lines when they are dry, but this may be brushed off. In such cases, if a little water is added to the bleaching solution there will not be any difficulty of this kind the next time it is used. If soda ash is not available, an efficient substitute can be prepared by using common baking soda. In this case, however, the lines are not quite so clear and sharp as those produced with the solution of soda ash. If it is desired to make colored lines, a preparation for this purpose may be made by adding ink to a solution prepared according to the preceding instructions. When this is done, the solution bleaches the blueprints so that the colored ink shows up well.—*Machinery*.



# RECENT DEVELOPMENTS ON THE FRISCO

## Work Checking System, Shop Schedules, Tools and Machinery, and Centralized Manufacture of Material

In connection with the other developments toward increased efficiency and economy which have taken place on the Frisco within the past year or two, a number of important and far-reaching improvements are being made in the mechanical department. While several of these are only fairly under way, the results obtained thus far justify describing and commenting

Piece-work has automatically performed this function on roads on which it has been introduced, and at the same time has developed more adequate and efficient supervision. It was not deemed advisable, however, to introduce this system on the Frisco, although it was felt to be vitally necessary to develop some method whereby a careful check might be made of the

DATE SHEET—TEN-WHEEL ENGINE—FIFTEEN DAYS IN SHOP

Day	Erecting Floor	Boiler Work	Bench Work	Machine Shop	Blacksmith Shop	Oxweld Plant
1—	Engine in shop					
2—	Engine stripped	Flues removed				
3—	Parts cleaned and delivered					
5—	Cylinders bored Valve chambers bored			Cylinder heads	Valve rods and stems Link work Piston rods	Valve rods and stems Link work Piston rods
6—				Cylinder bushings Valve bushings	Guides, yoke and blocks Misc. motion work Brake rigging Spring rigging Tumbling shaft	Crossheads
7—	Cylinder bushings applied Valve bushings applied			Throttle Dry pipes Eccentrics and straps Tumbling shaft	Rods Engine truck work Crossheads	Spring rigging Engine truck work Guides and blocks Reverse levers Brake rigging
8—	Valve chamber bored Throttle and dry pipe applied			Guides and blocks Engine truck work Spring rigging Brake work Rocker boxes Tumbling shaft boxes	Boiler brackets	Misc. motion work Misc. brackets Reach rod
9—	Frames and cylinders lined Guide yoke up Cab fittings ready		Tumbling shaft boxes Rocker boxes Spring rigging	Steam chests Wheels	Frame braces	Rods Frames Frame braces
10—	Tumbling shaft applied Rocker boxes applied Dry pipe and throttle applied Shoes and wedges laid off Frame braces applied Eccentric straps applied Center casting applied	Flues applied	Engine truck ready Guides and block ready	Crossheads Motion work Driving boxes		
11—	Driving boxes fitted Frames and cylinders bolted Running board bracket up Spring rigging up	Staybolts applied Boiler work completed	Steam chests ready Crossheads Reverse levers	Shoes and wedges Steam pipes		
12—	Boiler tested Steam chest applied Reverse lever applied Lagging applied Engine wheeled Steam pipes ready		Brake rigging Links	Rods and braces Pistons		
13—	Front end door and ring applied Cab and running boards applied Guides applied Shoes and wedges applied Motion work applied Pilot beam applied	Ash pan up	Main rods Side rods Pistons			
14—	Brake cylinders applied Air pump applied Steam and exhaust pipe applied and tested Valves set Pilot applied Jacket applied Cab fittings applied Piston applied Grate rigging applied	Front end netting applied				
15—	Brake rigging applied Rods applied Pipe work completed Engine trial tripped Engine painted					

Shop Schedule or Date Sheet for a Ten-Wheel Locomotive

on them at this time. The most important of these steps of progress will be considered briefly in the following article:

### WORK CHECKING

The locomotive and coach repair shops at Springfield—both the so-called new shops and the North shops—are administered on a day-work basis, and until recently no attempt has been made to check accurately the output of the individual workmen.

itemized output, and in a constructive manner, so that the features which restricted the output, such as lack of proper knowledge and training on the part of the individual, unsuitable tools and machinery, defective material, poor design of parts, inadequate supervision, and other features of this sort, might be located and remedied in order to bring the efficiency to a maximum.

Under the old methods a record was kept by a time clerk of the time when the men started and left off work in the morn-

ing, at noon and at night. The actual account against which the time was charged was based largely on the workman's statement or upon an approximation by the timekeeper. As a result the times charged against different jobs were not found to be of sufficient accuracy to make it possible to intelligently check against abuses or defects such as those which have been mentioned above.

To overcome this the Frisco has adopted a rather unique and unusual scheme. Work checkers have been provided, each one

higher rate than the standard for first-class mechanics. In all cases, in making suggestions or changes, they work through the foremen.

Among the most important advantages of the time checking system as it has been developed thus far, are the following: (a) The recording of the detailed progress of the work, thus making the work of supervision less burdensome for the shop superintendent and general foreman. (b) The detection of waste of time and effort at its occurrence, thus enabling the foreman to promptly take the matter in hand, eliminate delays and reduce the cost of performing the work. (c) Absolute accuracy of the charges to the various accounts or to individual locomotives or shop orders, thus making possible a correct analysis of expenditures. (d) Cost data, which permits comparisons to be made and weaknesses to be located which may be corrected by improving the facilities or methods employed or by rearranging the force.

Much has been published in the past concerning the best meth-

ST. LOUIS & SAN FRANCISCO RAILROAD									
DISTRIBUTION OF TIME									
Name <i>Heen W. J.</i>		No. <i>1523</i>		Rate <i>41</i>					
Day <i>Dec</i>		Month <i>Jan. 31</i>		Year <i>14</i>					
Time On	Time Off	Detail Description of Operation		Change	No. Pcs.	Hours	Amount		
7 <sup>30</sup>	2 <sup>00</sup>	26 holes plugged. Strap spring							
		Hangers rep. 6 Patches		Eng	2003	24	55	2.25	✓
2 <sup>00</sup>	3 <sup>00</sup>	Truck spring hanger sub end							
		dress		Eng	769	4	1	.41	✓
3 <sup>00</sup>	4 <sup>30</sup>	Taking heats for N03		L.O.	3377	2	15	.62	✓
Inspector <i>Harry B. Smart</i>						Foreman		Total <i>8. 3.28</i>	

Form Used by Work Checkers in Recording the Distribution of Time

of these looking after from 50 to 100 workmen, depending on the class of work and the department in which they are employed. There are two of these checkers in the erecting shop at the Springfield new shops, three in the machine shop, one in the blacksmith shop, two in the boiler shop and one in the tank and cab shop. These men constantly observe the progress of the work in the department which they serve, but have nothing to do with the distribution of the work. The checker has a card for each workman, similar to the one which is reproduced in the illustration, on which he enters in detail the operations which are performed, noting the times at which the work was commenced and completed and the engine or shop order to which each job is charged. These cards are 5½ in. by 8 in. in size. In the illustration spaces have been left between the different items in order to preserve a neat appearance in reducing the size of the form; this is not done in actual practice.

The checkers were selected from among the best of the me-



Boxes of Surplus Tools Which Were Gathered Up and Returned to Stock

ods of comparing the efficiency of one shop with another, the great difficulty being to define and decide on a standard unit of measurement. The value of the comparisons of a shop or a department as a whole on the basis of such units as have been suggested is questionable as far as it concerns the accurate detection of weaknesses or the relative value of different practices or methods. The most logical way of detecting lost motion

ROUTING CARD		
Engine No. _____		
REVERSE LEVER GANG		
Operation	Date Expected	Date Complete'd
Rocker boxes and arms ready		
Reverse levers ready		
Reverse levers applied		
Reach rod ready		
Reach rod applied		
Throttle lever ready		
Throttle lever applied		

ROUTING CARD		
Engine No. _____		
LINK GANG		
Operation	Date Expected	Date Complete'd
Tumbling shaft and boxes ready		
Links ready		
Links applied complete		
Walschart gear ready		
Walschart gear applied complete		

ROUTING CARD		
Engine No. _____		
STEAM PIPE GANG		
Operation	Date Expected	Date Complete'd
Steam pipes removed		
Dry Pipes removed		
Throttle Box Removed		
Steam pipes applied		
Dry Pipes applied		
Throttle box applied		

Routing Cards Used by the Reverse Lever, Link and Steam Pipe Gangs

chanics in each department, and the training which they receive in following up the work will fit them admirably for positions as foremen, if such openings occur. It should be understood that these men check the quality of the work and accuracy of workmanship, as well as the time of performing it. They are paid practically the same as lead men, which is at a somewhat

or effort, and of eliminating it, is to study each operation in detail and make sure that it is the best and cannot be improved upon. The provision of work checkers on the Frisco and the way in which their efforts are being utilized is successfully accomplishing this and in very greatly increasing the efficiency of the departments and the shop as a whole in a way which must



appeal to shop officers and foremen as being a most logical one.

WORK DESPATCHING

It seems strange that the railroads generally have been so slow in systematically planning the progress of the work through the shops in order to balance the strength of each of the various departments and to schedule the work of repairing the cars and locomotives in such a way that the entire staff may co-operate closely and effectively. The Chicago & North Western was one of the first roads to inaugurate such a system.\* This was many years ago, and in spite of the fact that it was given wide publicity and that the whole scheme was most logical, other roads took it up very slowly and even today shop scheduling in its best form is used in a comparatively few shops. The methods which are being used on the Frisco are not essentially different in a general way from those introduced on other roads but are arranged to meet the special needs of the shops on that system.

Not only are the dates set for the completion of repairs to each locomotive, but the intermediate times in which each of the numerous operations must be finished are also designated. The general plan of this scheme is indicated on the accompanying form, which is known as a date sheet, and outlines the work which should be done on the various parts of the locomotive in

Boiler and Floor Work, No. 1												
Engine number												
Date in shop												
Date expected out												
Stripped except frames and cylinders												
Flues removed												
Frames and cylinders removed												
Smoke box removed												
Flue sheets removed												
Door sheet removed												
Cylinders bored												
Valve chambers bored												
Valve bushing in												
Cylinder bushing in												

Part of a Department Schedule Sheet for Boiler and Erecting Shop Work

each of the different departments for a ten-wheel engine which is to be overhauled in 15 days, or rather 150 hours, for arrangements have been made to adjust the schedule for any lengthening or shortening of the working hours per day. This particular sheet covers an ordinary overhauling where no special work, such as firebox sheets, new cylinders or new frames, is required. Repairs of this sort necessitate lengthening the schedule by a certain number of days, depending on the nature of the special work.

\*American Engineer and Railroad Journal, February, 1904, page 58.

Similar date sheets have been prepared for every class of power and for every combination of repairs. As soon as a locomotive arrives at the shop a thorough inspection is made and a report is drawn up of the necessary repairs, from which it is possible to determine exactly what schedule should govern. This makes it possible to set the dates for the completion of each item and routing cards are filled in and issued to each gang or department foreman as a guide for handling the work. Sample

ROUTING SYSTEM---CHECK SHEET ERECTING SHOP NO. 1												
ENGINE NUMBER												
	Date Expected											
Engine in Shop	Date Compl't'd											
	Delay											
Engine Stripped	Date Expected											
	Date Compl't'd											
	Delay											
Parts Cleaned and Delivered	Date Expected											
	Date Compl't'd											
	Delay											
Frames down	Date Expected											
	Date Compl't'd											
	Delay											
Cylinders Bored	Date Expected											
	Date Compl't'd											
	Delay											
Cylinders Bushed	Date Expected											
	Date Compl't'd											
	Delay											
Frames up Complete	Date Expected											
	Date Compl't'd											
	Delay											
Guides Lined	Date Expected											
	Date Compl't'd											
	Delay											
Throttle Box in, Dome Closed	Date Expected											
	Date Compl't'd											
	Delay											
Rocker Boxes and Tumbling Shafts up	Date Expected											
	Date Compl't'd											
	Delay											

Check or Delay Sheet Used With the Shop Schedule System

cards, such as used by the reverse lever gang, link gang and steam pipe gang, are reproduced in the illustrations.

For the use of the shop foreman who supervises the work of these gangs a special form is made out which applies particularly to the work of his department rather than to the handling of the locomotive as a whole, as on the large date sheets. A sample sheet of this sort for boiler work and the erecting department is reproduced in one of the illustrations.

The despatching system is handled by a foreman who practically becomes an assistant to the general foreman, relieving that officer to a great extent of the detailed supervision of the progress of repairs. He makes out the despatching sheets, timing the various operations to correspond with the date sheet for the type of engine and class of repairs. It is, of course, necessary for him to maintain a master sheet covering all of the engines in the shop and arranged in such a way that he can see that the work in the various departments is properly balanced, and from such reports of the progress of the work as he receives and enters on the master sheets he can determine practically at a glance whether the schedules are being lived up to. A daily delay report is prepared each evening showing just what operations are behind schedule, and provided with this the general foreman can go directly to the gang or department which is responsible for the delay and see that provision is made to overcome the deficiency.

This system, in addition to maintaining a balance between the

different departments, thus eliminating annoying and costly delays and securing a maximum output consistent with the force and facilities, has the additional and inconsiderable value of insuring prompt delivery of completed locomotives at a date determined well in advance and thus enables the mechanical department officers to more intelligently handle the problem of the distribution of power. The shop schedule system to be a complete success must have the hearty support of all of the mechanical depart-

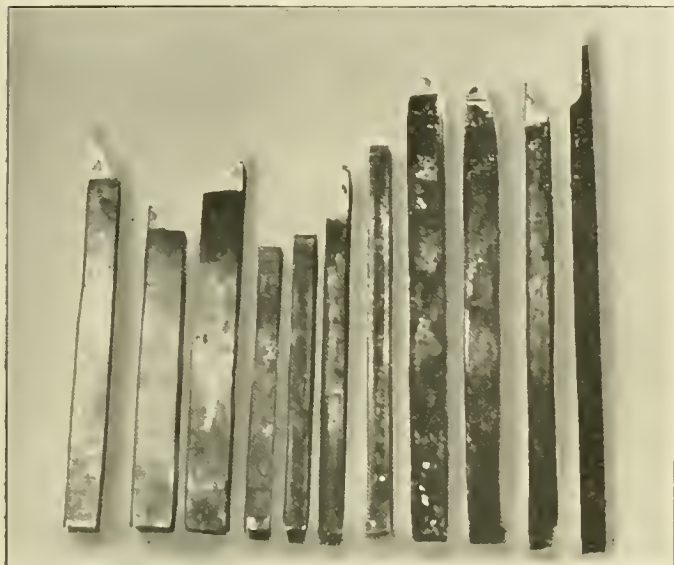

Eleven High Speed Tools Which Were Formerly Used With the Driving Wheel Lathe

ment officers and particularly of those higher officers having general supervision. If this condition does not obtain and the schedule is interfered with in order to give certain locomotives preferment, it would greatly hamper its usefulness and disorganize the entire shop.

SHOP MACHINERY AND TOOLS

No one who has ever tried to use a dull axe, saw or chisel, and who has then taken time to put them in proper condition



Tool Holder and Tools Now Used With Driving Wheel Lathe

and has marveled at their greater effectiveness, will belittle the effort to see that all of the tools and machinery in a large locomotive or car repair shop are kept in first class condition. Possibly a given amount of energy and expense invested in work of this kind has resulted in more striking improvements in efficiency

and output than any other one thing that has been advocated in the general campaign for improved shop production within the past few years. Many of the more progressive roads have been prompt to take advantage of this, although some of them have not as yet fully awakened to its possibilities. It was one of the first things which were done by the Frisco in its campaign for improved shop efficiency, and the results thus far have been startling, in that the maintenance expenses for shop machinery and tools have been surprisingly decreased, although this equipment is much improved and maintained in better condition.

The problem was approached from several angles. It has in-

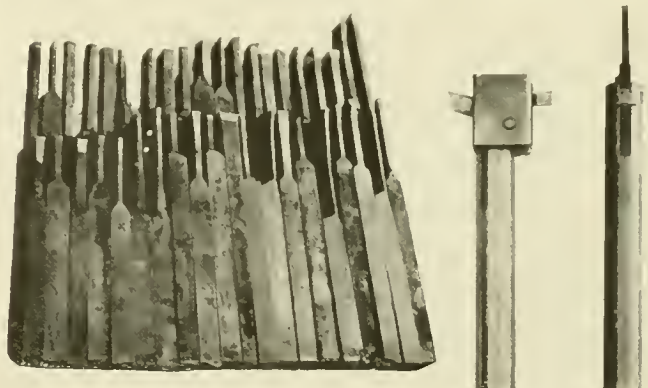

Forty-One Tools Formerly Used on Slotter

Tool Holder Now Used on Slotter

involved the appointment of a supervisor of tools, who has had general charge of the work, which in general includes the standardization and centralized manufacture of small tools and a systematic method of checking them and seeing that a complete and adequate supply, but not an over supply, is maintained at all points on the system. It includes also the strengthening and speeding up of machine tools and the providing of jigs and other apparatus for the accurate and rapid handling of the work. It should be noted, however, that in this latter respect the Frisco, particularly at the Springfield new shops, has not been in the rear ranks in the past. This is indicated by the shop kinks from that system which have been published in the *Railway Age Gazette, Mechanical Edition* from time to time, and particularly in the collection which appeared in July, 1913, submitted by J. C. Breckenfeld, at that

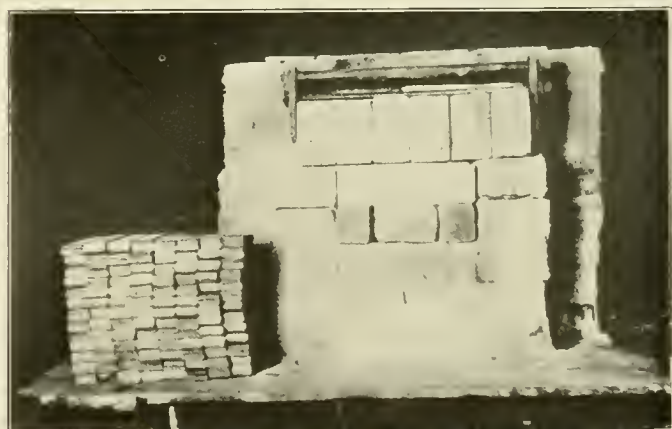

Special Furnace for Making All Lathe, Planer and Similar Tools for the System

time assistant machine shop foreman, who was awarded the first prize in the shop kink competition in which it was submitted. Mr. Breckenfeld is now supervisor of tools.

One of the first steps in the campaign was to make an absolutely correct inventory of all the machinery and tools on hand at the different shops and engine houses. This resulted in the collection of a large amount of obsolete tools, which have either



been worked over or sold as scrap, and also in the gathering up of surplus tools, which have been turned back into the stock and have been reissued as required. For instance, one of the illustrations shows a number of boxes filled with perfectly good tools, but which were in the nature of surplus stock and were turned over to the general store, the shops from which they were collected being given a credit of \$2,005.41. This is only one of a number of similar lots of surplus tools which were gathered up.



Finished Tools Ready for Issuance to Shops

In another case a large number of antiquated air motors were collected and disposed of which were using 300 per cent more air than the standard tools. Other tools were gathered which were damaged and laid aside, but which at reasonable expense were placed in first class condition and reissued as new tools. Meanwhile a stock book has been prepared which shows all small tools on hand each month at each point and those which have been ordered. A continuous inventory is thus provided which makes it possible for the supervisor of tools to quickly and accurately check the requisitions and thus avoid overstocking.

Not the least important of the improvements has been the selec-

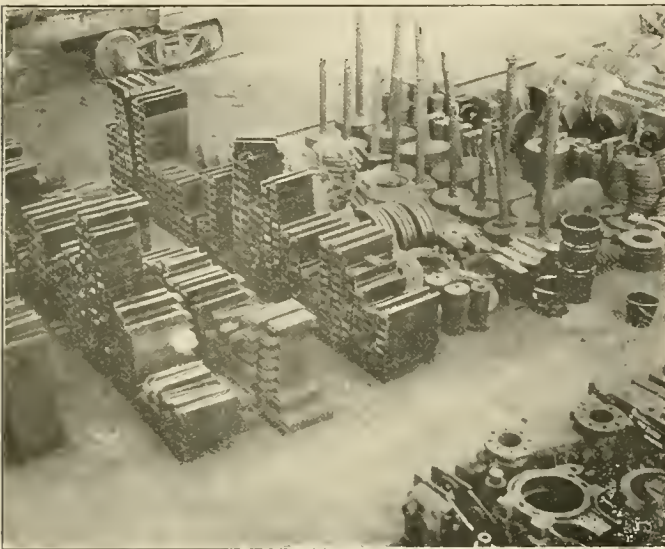

Locomotive Parts Manufactured at Central Shop

tion of standard designs for the different tools and the centralization of their manufacture at the main shops. As a typical example, the heavy bulky tools formerly used on the driving wheel lathes have been replaced with tool holders and high speed steel cutters, as shown in the illustrations. This has not only decreased the cost of these tools, for only the cutters are now of high speed steel where formerly the entire tool was of this ma-

terial, but it has greatly increased their efficiency, because of the better design, and has made it possible to more easily maintain the tools in proper condition. As another illustration, one of the slotters was found to have 41 tools weighing more than 500 lb., 70 per cent of the tools being of high speed steel and representing in all an investment of over \$500. These were replaced with two tool holders similar to those shown in one of the photos, and a full set of small tools of high speed steel. The total cost of these new tool holders and tools was less than 20 per cent of the cost of the old tools and they are more effective than the large clumsy ones.

In keeping a check on the small tools a record is maintained at each of the shop tool rooms showing just what tools each man has and requiring him to turn in any tools, which he may have taken from the tool room, every Saturday night for inspection

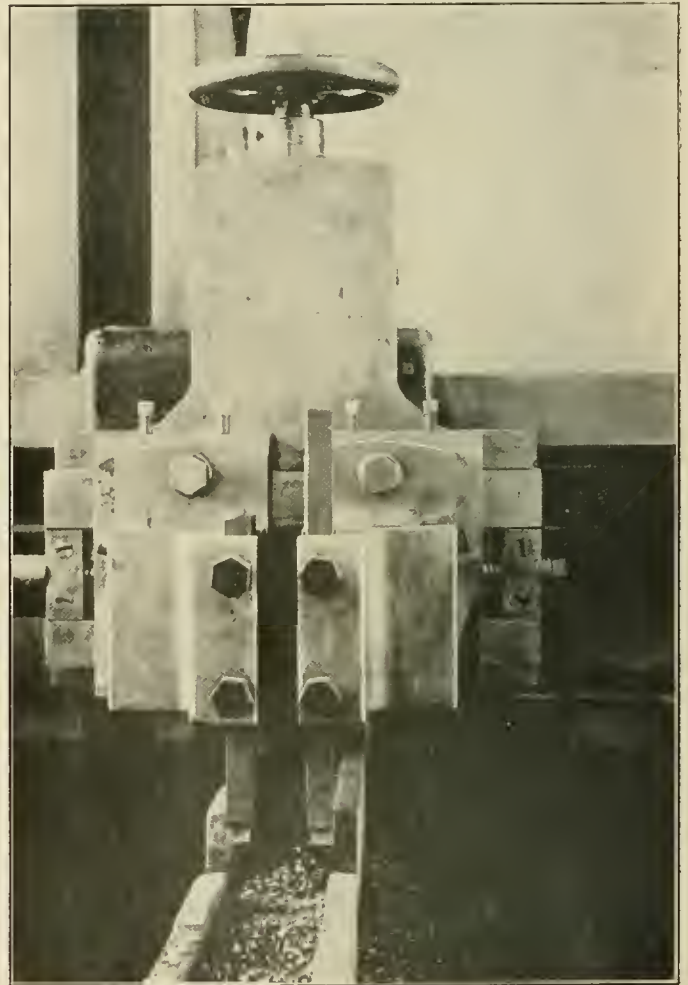

Double Planer Head for Machining Shoes and Wedges

and repairs. If any of the tools are found missing the man is notified on Monday morning that if he does not immediately turn them in he must get a release from the general foreman. If a tool is broken the workman must turn in a report which must be passed upon by his foreman. In this way weak or poorly designed tools are located and improved and careless handling is reduced to a minimum.

It was found that there were a great variety of makes of tools of all kinds scattered over the system. As rapidly as possible it is proposed to reduce the number of different types; in the case of jacks, for instance, from 12 to four, and to standardize four sizes of air hammers and five sizes of air motors. Manufacturing the small tools on a large scale at a central shop reduces their cost very greatly since it is possible to furnish special facilities and specially trained mechanics. The tools shown ready for is-

suance in one of the illustrations, for instance, are now made at a cost of less than one-half that under the old methods.

In brief, then, the principles which have been applied and which have resulted thus far in an increased efficiency of machine equipment with a decreased cost of maintenance are an intimate constant supervision of tool purchase, manufacture and distribution;

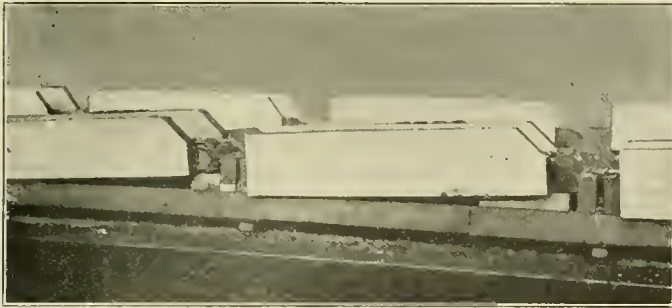

Special Device for Holding Shoes and Wedges on Planer

the establishment of standards of design for all small tools; the central manufacture of these tools in quantities to insure minimum cost and adherence to standards; the designing and installation of time and labor saving jigs to facilitate shop output; and the strengthening and rebuilding of machine tools to increase their capacity and their facility for turning out accurate work.



Finished Locomotive Parts on Storehouse Platform Ready for Shipment

CENTRALIZED MANUFACTURE OF MATERIAL

Considerable progress has been made in the standardization of certain locomotive parts and the manufacturing of this material on a large scale at the central shops. The practice of furnishing material in the rough to the small shops and engine houses is usually an expensive one because of inadequate tool equipment at such places. While the reduction in the cost of the finished ma-

terial when manufactured in quantity at a central shop is an important advantage, it is not the greatest one. Where a supply of finished material is on hand ready for immediate application to the locomotives, the time in making repairs is very greatly decreased, whether these repairs are made at the larger shops or in the smaller shops and engine houses. Moreover, parts which are continually being worn out and broken in service may be replaced with little or no loss of time and the condition of the power is thus always maintained at a high point of efficiency. This means fewer engine failures, a reduction in running repair costs and an increase of mileage between shoppings. This is particularly important where the practice is to haul heavy tonnage trains, utilizing the full capacity of the locomotives, as has been done on the Frisco during the past year.

At present a considerable number of parts are either wholly or partially machined in large lots at Springfield and are shipped to the smaller points where the machine operations are reduced to a minimum. Many locomotive parts may be finished in quantity with special jigs and machinery at a small part of the cost which would be required at one of the smaller shops where the investment in special tools and machinery is not warranted. As an illustration, the centralized manufacture of shoes and wedges may be mentioned. When these are machined at a small shop or engine house in small quantities the labor cost runs from 40 to 75 cents apiece. With the special jig and double planer head arrangement at Springfield, shown in one of the illustrations, it is possible to machine these in lots of 40 at a cost of 10 cents each. The plan is to carry this development to a point that such parts as fireboxes, back ends and frames will be kept in stock, thus making it possible to return an engine requiring such repairs to service in a very much shorter time than would otherwise be necessary.

MILLING MACHINE EFFICIENCY

BY OWEN D. KINSEY  
Tool Foreman, Illinois Central, Chicago, Ill.

With the installation of modern tool manufacturing machinery in the Burnside (Chicago) shops of the Illinois Central the productive capacity of milling machines appeared inadequate to handle the increased volume of work coming from the engine and turret lathes. Investigation disclosed many opportunities for improvements and a marked advance has been brought about by making radical changes in milling methods, in many instances speeds and feeds having been more than doubled. Numerous experiments have been made with the new style undercut, wide

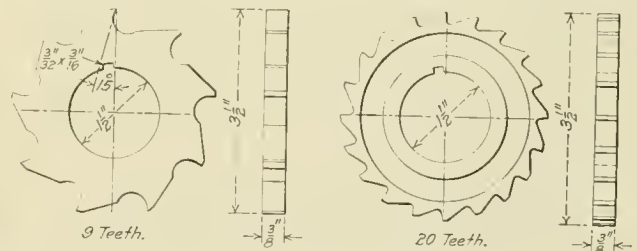

Fig. 1—Left, New Style Slotting Cutter; Right, Old Style Slotting Cutter

spaced cutters and advantage taken of the extensive experiments conducted in the works of the Cincinnati Milling Machine Company, to whom the writer is indebted for many valuable ideas and suggestions relating to modern milling machine practice.

A. J. Baker, of the Cincinnati Milling Machine Company, in a paper read before the Western Railway Club, made the following statement, the truth of which will be strikingly apparent to all who have had experience in handling metal-cutting tools: "A milling cutter is probably more unfortunate than any other tool, inasmuch as the user expects the one cutter to perform with equal



efficiency whether cutting cast iron, steel or brass." He states that in every case of which he knows the rake supplied on cutters is no rake at all, excepting in face mills; in other words, attempts

some provision made for the chip to escape if a free cutting action is to be obtained. A milling cutter is usually ground radial with the center and there is little or no opportunity for the chip to escape, consequently it pushes the chip through the work, generating heat and vibration, which are two of the most destructive

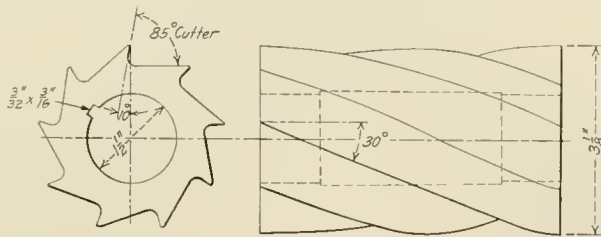

High Speed Steel. 9 Teeth.

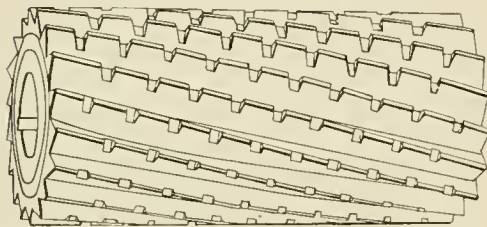

Fig. 2—New Style Milling Cutter Above; Old Style Below

are made to use on a milling machine a cutter that a lathe or planer hand would indignantly reject.

A lathe or planer tool probably exemplifies the most true cutting

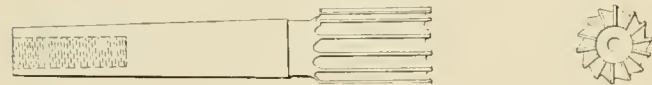

Fig. 3—Old Style End Mill

action of any metal cutting tool and it is a well known fact that a slight change in the angle of rake has a marked effect on its cutting efficiency and the power required to drive it. The thought

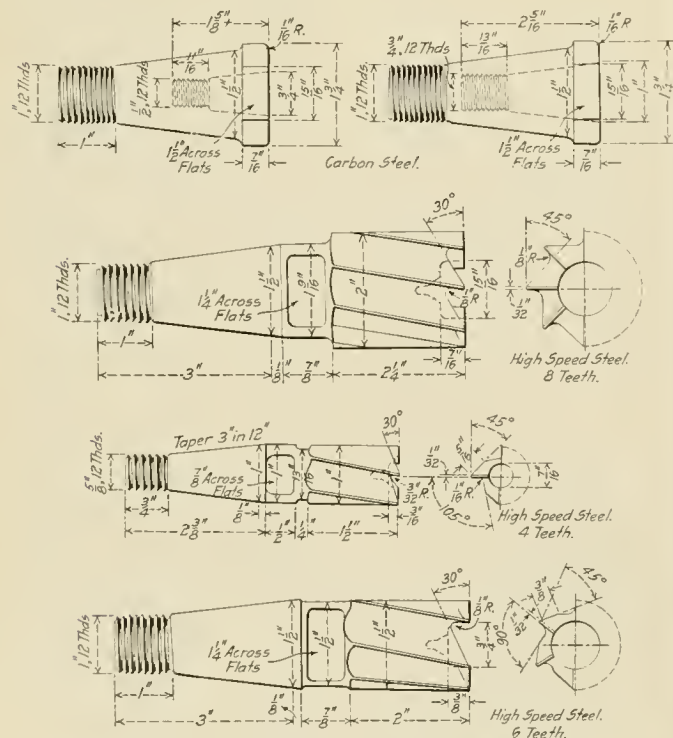
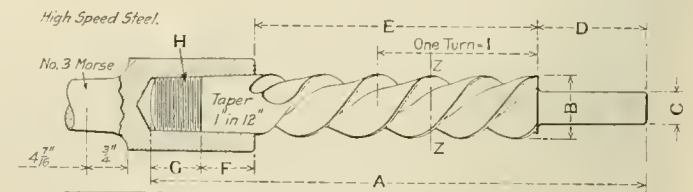

Fig. 4—New Style End Mills, and Bushings

to be kept in mind is that metal cutting is produced by the driving of a wedge-shaped tool between the work and the chip, separating it in a parallel line of cleavage; therefore there must be



Size of Piston Key	A	B	C	D	E	F	G	H	I
5/8	9	21/32	5/8	2	5/4	1	3/4	3/4, 12 Thd	2 1/2
3/4	9	25/32	5/8	2	5/4	1	3/4	3/4, 12 Thd	2 1/2
7/8	9	29/32	5/8	2	5/4	1	7/8	1, 12 Thd	2 1/2
1 1/8	9 1/2	1 1/32	5/8	2	5/4	1	7/8	1, 12 Thd	3

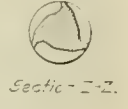

Fig. 5—Helical Cutters for Piston Rod Keyways

causes which affect a cutting tool. The design of the milling cutter is of vital importance and a radical departure from standard cutters must obviously be considered if any marked advance is to be made in the art of efficient metal cutting. More depends on the design of a cutter and the manner in which it is presented

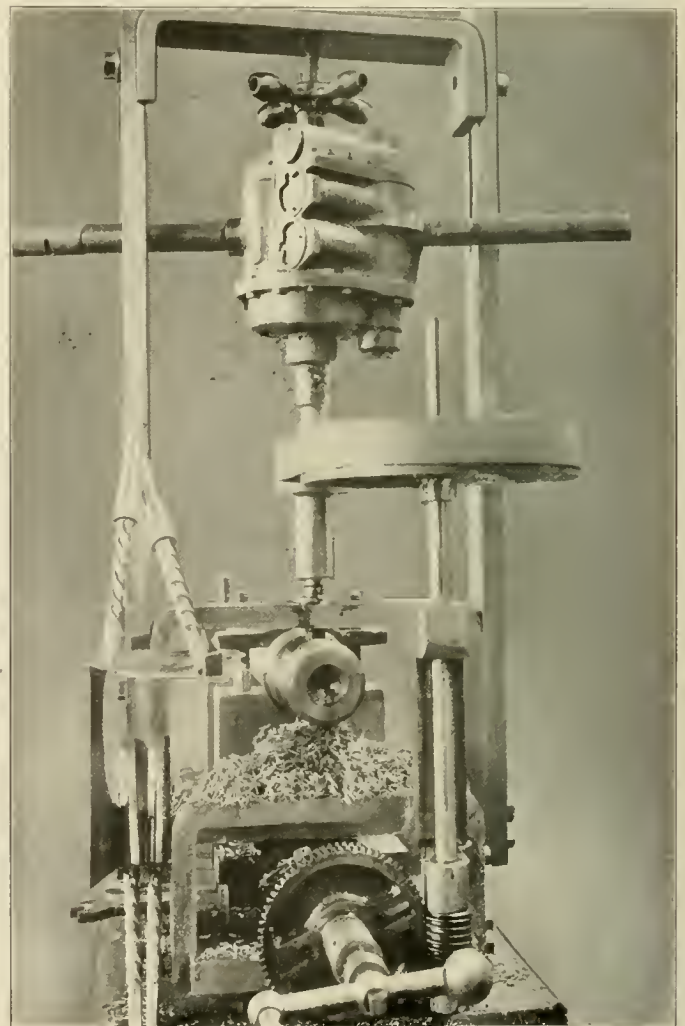

Fig. 6—Machine for Milling Piston Rods

to the work than the kind of steel used in its manufacture. This is shown in a surprising manner by experiments in which we have made comparisons.

Fig. 1 illustrates a modern and a standard slotting cutter with

which we made a comparative test. These cutters are of the same diameter and width and have a 1½ in. arbor hole. The material milled was machinery steel in which a cut 3/8 in. in width and 13/32 in. in depth was taken and the work was the milling of keyways in taper shank arbors, supported on centers. The standard cutter, working at 115 r. p. m., or 93 feet, and at a table travel of 2 3/4 in.

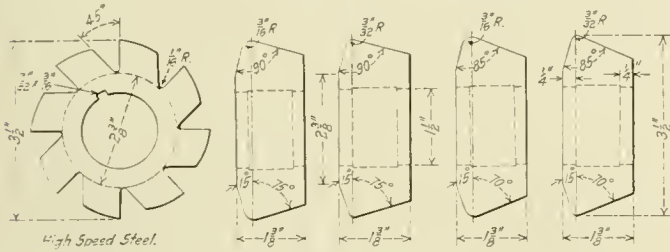

Fig. 7—Milling Machine Cutters for Washout Plug Taps, Etc.

per minute, could not be crowded further. The modern cutter was then started to work at the same speed and feed and was stepped up to 350 r. p. m., or 285 surface feet. The tumbler block controlling the feed was then advanced from 2 3/4 in. per minute up to 16 in. table travel per minute without the least sign of damaging effects to the cutter, or discoloration of the chips. We were unable to make further increases owing to difficulty in holding

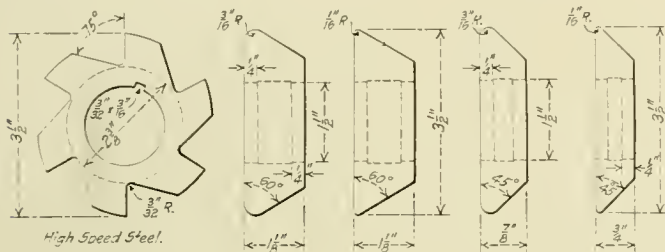

Fig. 8—Milling Machine Cutters

the work. This test was made without stream lubrication, which tends to show the possibilities of increasing milling machine productive capacity by correcting the design of the cutter.

Fig. 2 shows a comparison of old and new style milling cutters. The modern cutter has nine teeth while the standard cutter has eighteen. The modern cutter has teeth set at an angle of 30 deg. and ground with an undercut of 10 deg., the arbor hole being 1½ in. and the outside diameter of the cutter 3 3/8 in. The stand-

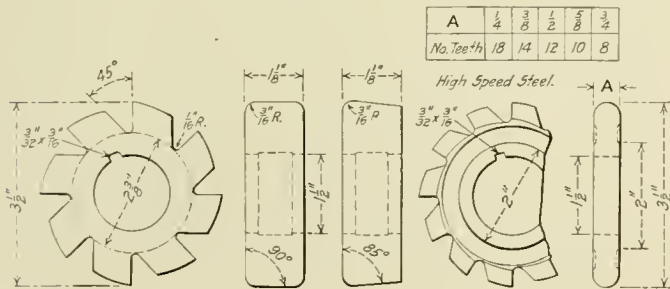

Fig. 9—Fillet and Convex Cutters

ard cutter has twice as many teeth and they are ground radial with the center. The angle of the spiral is 10 deg. and little or no fillet is provided at the root of the face. The diameter of the cutter is 3 1/2 in. and the arbor hole is 1 1/4 in.

It is apparent that the spiral is better than a straight cutting blade, as it allows an escape for the chip and produces a shearing action. Referring to the illustrations, attention is directed to the sweeping curves representing the cutting edge of the modern cutter and the straight appearance of the standard cutter. Thus we can see why the modern cutter cuts freely and can be operated at

so much greater speed, without generating heat. In the modern cutter there is no necessity for chip breakers; in fact they would be detrimental if used, although they may improve the standard cutter. The wide spacing of teeth gives more strength to the cutting edge and permits the chips to escape freely. Moreover with the wide spacing of teeth the power which drives the cutter

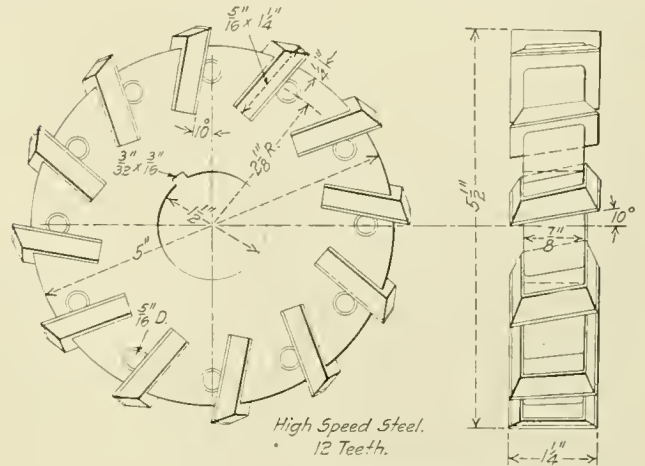
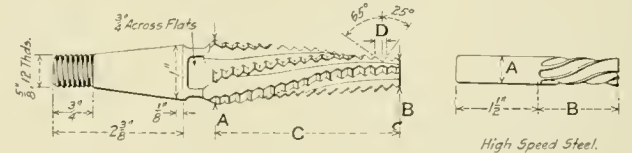

Fig. 10—Standard Straddle Mill

is concentrated behind fewer cutting edges, whereas in the case of the standard cutter this same power is distributed and increased effort is required of the machine.

Fig. 3 illustrates an old style end mill and Fig. 4 shows the style of end mills we are now using. These mills cut, instead of scrape, as is not the case with the old style cutters. Attention is



14 Pitch, L.H. Spiral.

Size	A	B	C	D
No. 1	1/8	7/16	3	5/32
No. 2	1/8	9/16	3 1/2	3/16

Size	A	B	No. Teeth	Pitch	Spiral
1/4	3/8	1 1/2	6	6.12	L.H.
3/8	1/2	2	6	6.22	"
1/2	3/4	2 1/2	6	6.48	"
3/4	1	3	6	7.29	"

Fig. 11—Cutter for Alligator Wrenches; and Straight Shank Side Mills

called to the 3 in. in 12 in. taper shank, which we have made a standard for all our milling machines and attachments. This shank holds the cutter rigidly and owing to the short piece of steel required to make a cutter, shows economy in the use of high speed steel. The superiority of this style of end mill must be

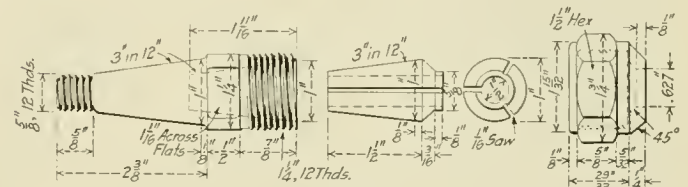

Fig. 12—Chuck for Straight Shank Mills

apparent to any one familiar with milling cutters. The old style end mill has many more teeth, consequently less strength and less chip clearance.

Fig. 5 illustrates a helical cutter used very successfully in milling the keyways of locomotive piston rods. We use four sizes of this style of cutter in the Burnside shops and mill our keyways in from 15 to 20 minutes. The action of the cutter is very inter-



esting as it cuts rapidly and throws the chips in a screwlike manner. The chips are spiral in shape and are quite long. The action of this helical cutter is a strong argument in favor of spiral cutting mills such as that shown in Fig. 2. The machine in which these cutters are used is shown in Fig. 6. It was designed by the general foreman at Burnside and will cut an average size keyway in 30 minutes, floor to floor.

Figs. 7, 8 and 9 show a group of grooving mills which we

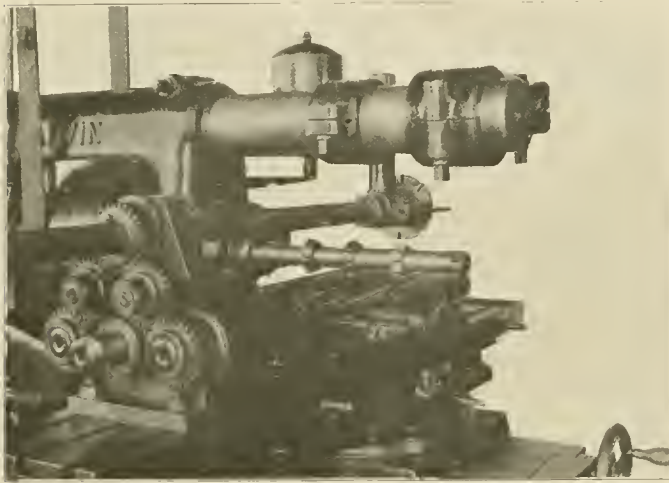

Fig. 13—Triple Head Milling Machine

have adopted as standard. They cover a wide range of railroad work and, as may be noted, have 1½-in. arbor holes, our standard arbor being 1½ in. in diameter.

Fig. 10 shows an improved straddle mill which is particularly efficient. We use this style of cutter in pairs for machining the tangs of drill sleeves, repair sleeves and numerous taper shank tools. We often run lots of 500 at a time and finish the tang complete in from one to one and a half minutes each, which is approximately ten times faster than the old method which was to

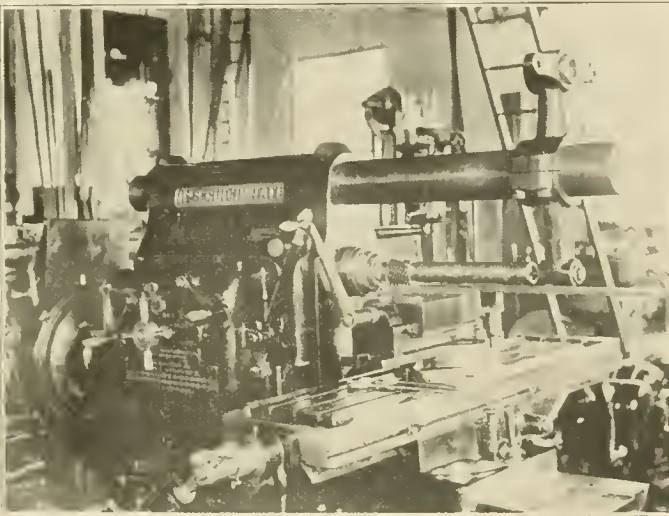

Fig. 14—High Speed Slitting Saws Making Rose Reamer Blades

place them on centers and mill one side at a time by revolving the dividing head. We straddle mill the squares on washout plug taps and reamers at greatly reduced costs. Our method is to rough turn the material in the turret machine and clamp in a V-block on the milling machine.

Fig. 11 illustrates a cutter used in making alligator wrenches and also a straight shank side mill. The chuck for holding this mill is shown in Fig. 12. It is made in the tool room and is used for a number of purposes. By its use considerable high speed

steel is saved in manufacturing tools such as the straight shank side mill as the shank can be made very short; in this case only 1½ in.

Fig. 13 illustrates an original triple head milling device, which mills spirally three reamers at one operation, reducing the cost of reamer milling fully one-third. We regularly mill three spiral 16-in. rod reamers in from three to four hours, taking one cut for each flute. An apprentice operates this machine and we use this same device for sawing sectional tube expanders and other similar work. We average from 33 to 36 expanders in nine hours.

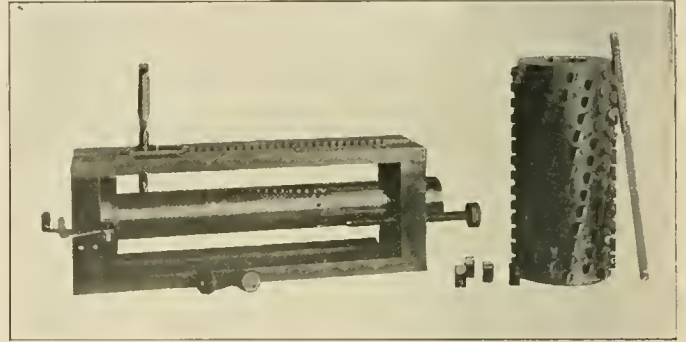

Fig. 15—Drilling Jig for Peg Slab Milling Cutters

Fig. 14 shows a gang of high speed slitting saws on a Cincinnati miller which accurately saws ten high speed blades 5/32 in. by 3/8 in. by 3 in. in one operation, producing 250 pieces in a day of nine hours. These blades are used in manufacturing inserted blade rose reamers, the bodies of which are machinery steel. The cost of cutting one set of eight blades is 3½ cents.

Fig. 15 shows a drilling jig in which we drill and ream bodies for inserted peg slab milling cutters. Cutters produced on this jig are undercut ten degrees and have all the characteristics of a modern milling cutter. We use this style of cutters on a rod milling machine on which it is a common practice to take a cut 3/8 in. in depth, 8 in. in width at 8-in. table travel per minute, the steel being of 75,000-lb. tensile strength. A dowell pin is placed in each peg to prevent it from turning under pressure from the

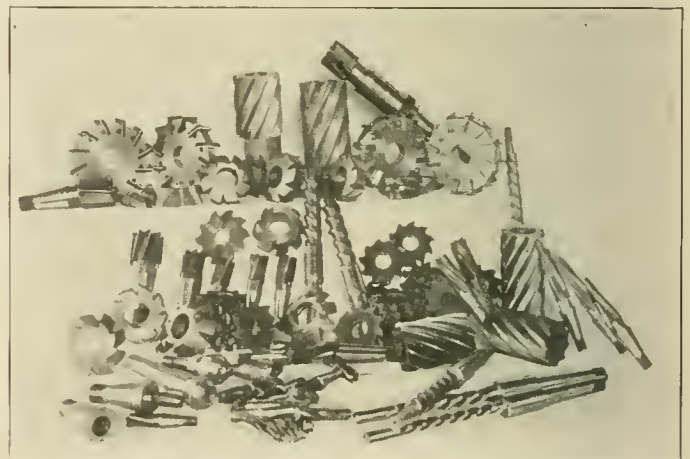

Fig. 16—Group of Tool Room Milling Cutters

work. The teeth for these cutters are machined complete in accurate jigs and when driven in place the dowell pin serves to bring the cutting edges in perfect alignment. The cutter shown was manufactured complete by unskilled workmen and exemplifies what can be accomplished by introducing modern methods in railway shops.

Fig. 16 shows a group of milling cutters that were made and are used at the Burnside shops.

# NEW DEVICES

## ROTARY AIR COMPRESSOR

The Wernicke-Hatcher Pump Company, Grand Rapids, Mich., has recently placed on the market a rotary air compressor that is rather unique in principle and design. It consists essentially

of a rotor and rotor case that revolve independently of each other at the same speed, but not on the same axis, together with the valves and driving mechanism. The machine is shown

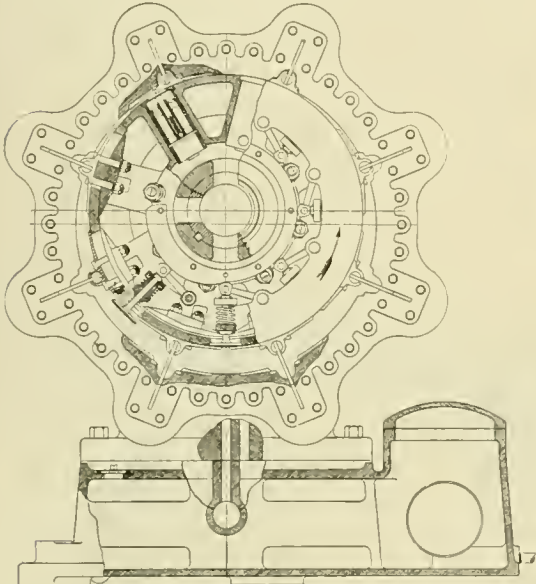

Cross Section Through Rotor Case of Type B Compressor

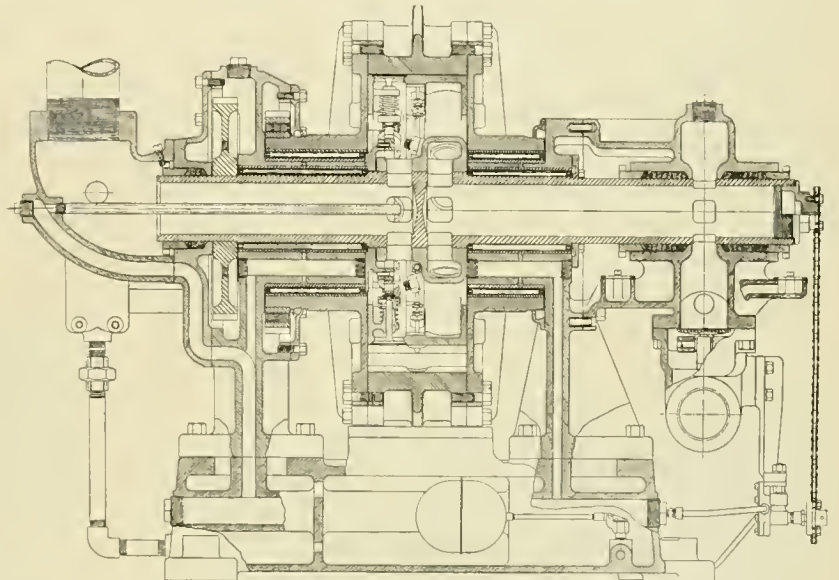

Longitudinal Section Through Rotary Air Compressor

of a rotor and rotor case that revolve independently of each other at the same speed, but not on the same axis, together with the valves and driving mechanism. The machine is shown

valve in the rotor to a passage in the other end of the rotor shaft. The vanes, which are provided to create the pockets, slide in slots in the rotor case, and the shoes in which they are held

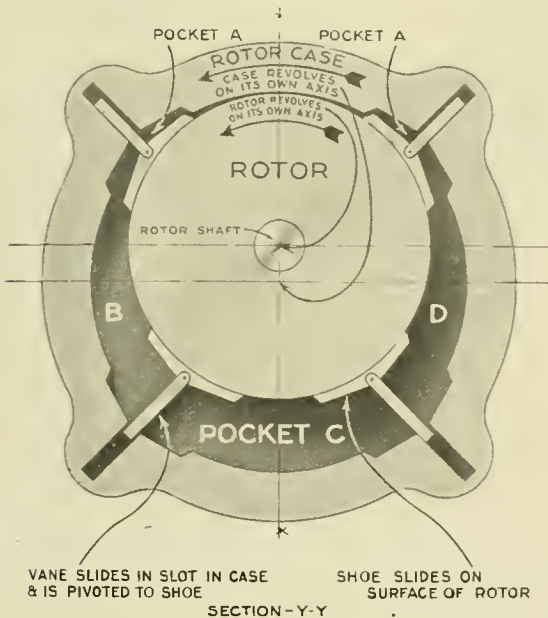

Simplified Drawing of the Rotary Air Compressor, Showing Its Operation

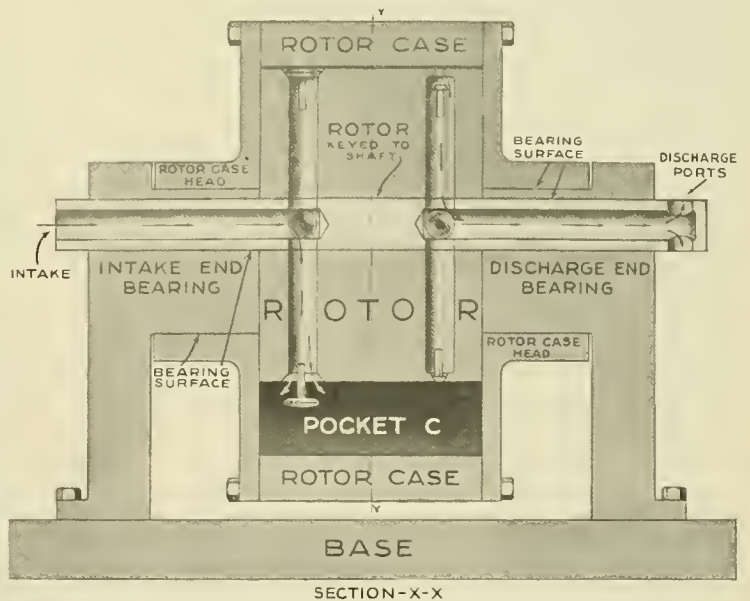

SECTION-X-X

in the illustrations and its operation is well illustrated by the simplified drawings shown in one of them.

The air is drawn in through one end of the rotor shaft and the intake valve by the partial vacuum caused by the increasing volumes of pockets A and B. In the position shown pocket

are free to slide on the surface of the rotor, the construction being shown in the cross section. These vanes are carefully fitted in the slots to eliminate the leakage of air from one pocket to another, and as the greatest pressure is always on the leading side of the vanes, it is only necessary to have the back of the



vane make a perfect seat with the corresponding surface of the slot. The intake valves are mechanically operated by means of a cam, as illustrated, and are opened for nearly one-half of the stroke. This permits of having a spring stiff enough to prevent leakage by this valve and to overcome the centrifugal force at all speeds within the rated maximum.

It is not necessary to provide any means of cooling, as the surface surrounding the compressed air is sufficient to radiate a large part of the heat generated by the compression of the air. In this regard tests have shown that with an intake temperature of 60 deg. Fahr., the temperature of the discharge when operating continuously against a pressure of 100 lb. is about 275 deg. Fahr. This radiation is also helped by the rapidly revolving rotor case. As may be expected, the rotating parts are carefully balanced in order to relieve the vibration that might be caused by revolving such heavy masses, and the makers claim that this is so carefully done that no foundation is necessary other than the bed of the machine. Roller bearings are provided at five different points on the shaft, and the friction caused by the other sliding parts is small, as they have a relatively small and slow motion. A forced feed lubricating system is used, the oil pump being driven from the end of the shaft by a chain and sprocket wheel.

The pump may be driven by a direct connected motor or by

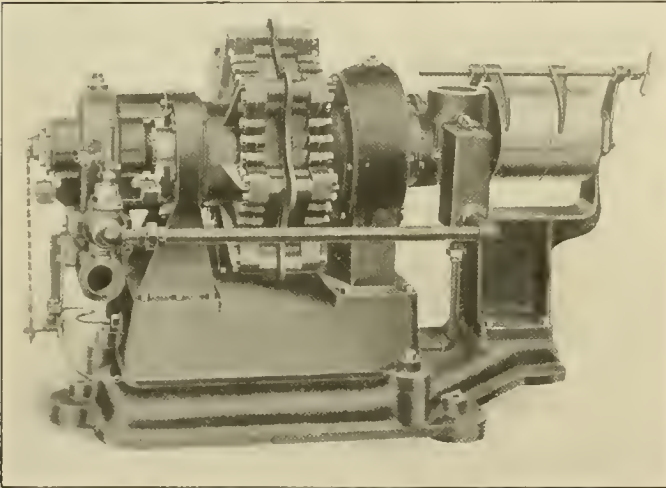

Type B Single Stage, Power Driven, Rotary Air Compressor

a belt, as shown above. The machine illustrated is type B, which has an approximate capacity of 75 cu. ft (actual delivery, not displacement) when operating against a gage pressure of 100 lb. and at a maximum speed of 400 r. p. m. A 20 h. p. motor when direct connected will drive this pump at this speed and pressure. This machine, it is claimed, is particularly serviceable where constant pressures are to be maintained, as it can be controlled automatically when driven by an electric motor. When greater capacity or higher pressures are desired, these pumps may be connected in parallel or series, as required.

**ALLOY STEEL GEARS IN MACHINE TOOL CONSTRUCTION.**—Considerable experimenting has been done by machine tool builders in an endeavor to follow automobile manufacturers in the use of alloy steel gears in gear-boxes and other power transmitting units of machine tools in order to prevent breakage and stripping of gear teeth. Alloy steel, such as chrome-vanadium and chrome-nickel has been used with more or less success. Where it is possible to make a complete analysis of the steel before working it up, it has been found that alloy steel gives far more trouble than ordinary carbon steel. The limits of fluctuation in heat-treatment are much narrower than in ordinary carbon steel, and the material must be handled much more carefully if good results are to be expected.—*Machinery*.

## GRAPHIC SERVICE RECORDER

An instrument for recording machine tool operations has recently been placed on the market by the Esterline Company, Indianapolis, Ind. It operates on the same general principles usually employed in graphic or curve drawing instruments, and is equipped with any number of electrically controlled pens desired, from one to ten, inclusive. The entire instrument is mounted in an enameled metal case, with rubber-covered binding posts located at the bottom for making connections and suitable lugs at the top and sides for fastening to a wall or partition. The front cover enclosing the chart and clock is provided with glass panels on the sides, top and front to permit inspection of the record without opening the instrument.

The pens rest on a long strip of paper or record chart which is driven through the meter at a constant rate of speed by a high-grade jewel balance wheel type eight day clock. The clock may be equipped with gears giving five paper speeds of  $3\frac{1}{4}$  in.,  $1\frac{1}{2}$  in., 3 in., 6 in., or 12 in. per hour. An attachment can also be provided, giving additional chart speeds of 45 in., 90 in., 180

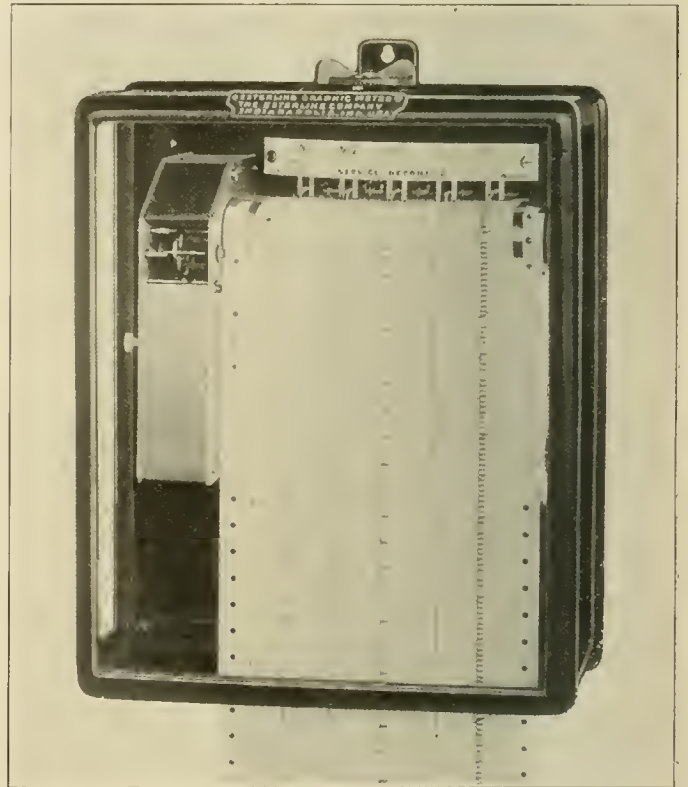

Esterline Graphic Recorder

in., 360 in. and 720 in. per hour. The clock is provided with a regulator for adjusting the speed in service, and with stops so that its operation may be interrupted at any time. A re-rolling device is furnished for winding up the finished record in the bottom of the case. This may be omitted if desired, and the finished chart fed through a slot in the bottom of the cover, the record being torn off daily. Record charts are supplied in rolls 90 ft. in length and six in. in width, which may be torn into short lengths for convenience in filing. Perforations are provided along each margin of the chart, which are engaged by pins on the driving roll to insure perfect alinement and accurate timing of the paper.

Each pen is so controlled that when a record is made a vertical line about one-eighth inch in length is drawn across the chart, the pen returning to the zero position after each record is made. The controlling devices for the various pens are connected to different machines in such a way that one record is produced for each operation or for a certain number of operations. The





## POSITIVE LOCKING STEAM HOSE COUPLER

A steam hose coupler having a positive locking device and a gravity trap has recently been introduced by the Gold Car Heating & Lighting Company, New York City. As shown in the illustration these couplers operate in the ordinary way and are interchangeable with other makes. When coupled the joints may be locked by driving the wedge of one coupler over the toe of the other. The wedges are drop forgings held in place by springs, and the ends are upset to secure them to the couplers.



Steam Hose Coupler with Positive Lock and Safety Trap

Vulcabeston gaskets of the oscillating type developed by this company have been used, and the couplers are equipped with gravity traps. The trap valves are designed to remain seated while under pressure and to open by gravity when the pressure is released, thus draining the hose connections of all condensation, and serving as a protection against scalding when disconnecting the couplings.

## FUEL OIL BURNER

A fuel oil burner so arranged that the oil is atomized and mixed with air outside of the burner has been developed by H. B. Stilz, 1938 North Marvine street, Philadelphia, Pa. The arrangement of the parts of the burner is shown in the sectional drawing. Oil under 50 lb. pressure enters an inner nozzle through the small pipe shown at the top of the burner. Near the orifice is a spiral which gives the oil a rapidly whirling motion, thus causing it to spread out in a cone-shaped film as it leaves the burner. Surrounding the inner

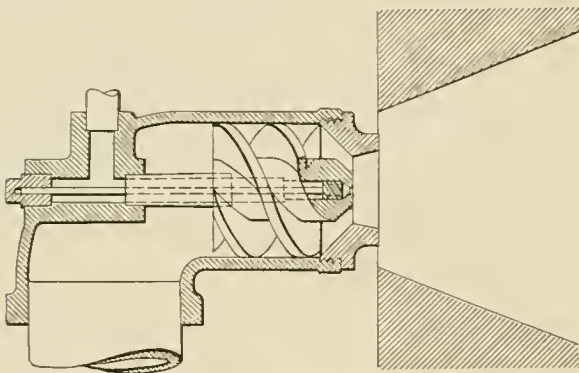

Fuel Oil Burner with Outside Atomization

nozzle is a casing enclosing a large spiral through which air or steam is forced under about 8 oz. pressure, being thus delivered from the discharge orifice in a whirling cone with a backward suction at its center. This suction draws the oil film into the whirling current of air where an intimate mixture is effected. By varying the shape of the outer orifice any shape of fire desired can be produced so that for any type of furnace the admission hole through the furnace wall can be completely filled with flame. As the high velocities at

the nozzle are rotative, the atomized oil does not advance faster than the rate at which air is drawn into the furnace by the chimney draft. This is claimed to insure ample time for the mixture of sufficient air from the induced draft to effect complete combustion of the fuel within a small space in front of the burner and the admission of an appreciable excess of air into the furnace is unnecessary. These burners are built in sizes capable of handling from less than one gallon of oil per hour to 400 gal. per hour. They are claimed to be suitable for every variety of fuel oil and with proper provision for preheating the fuel have been successfully used to burn tar.

## FOUR-FEED FLANGE OILER

The Chicago Injector Company, Chicago, has placed on the market a four-feed flange oiler for use on switch and Mallet locomotives, or any other type which requires flange oiling on four drivers. This system, also known as the Elliott system, works on the principle of an ordinary lubricator, the oil being placed in the oil bowl and forced through the sight feeds by steam pressure to nozzles located two inches away from the flange of the driver to be lubricated, and about half an inch in front of the tires. A steam connection is made to the lower

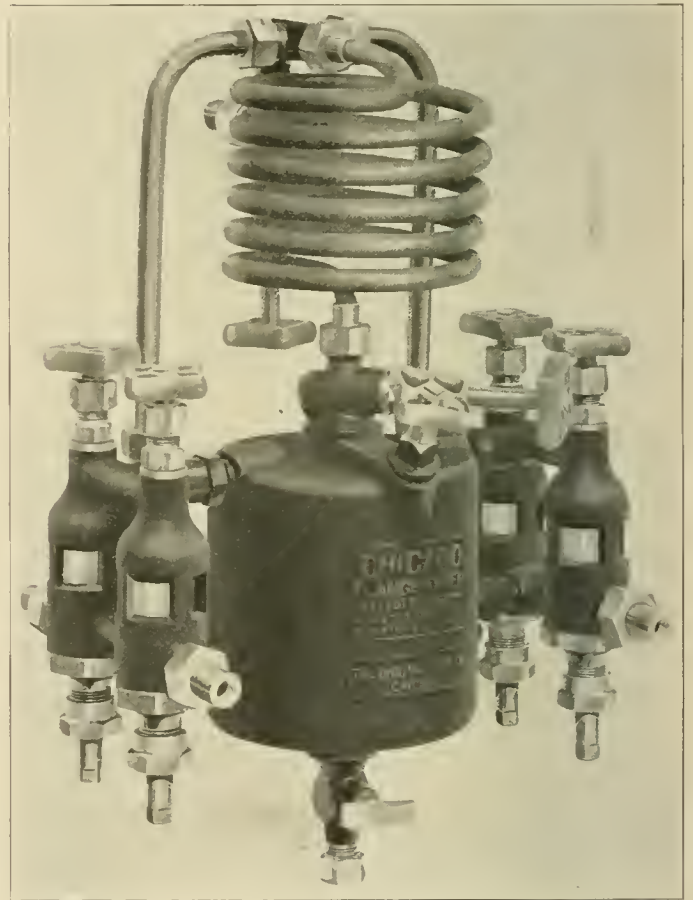

Chicago Flange Oiler with Four Feeds

side of the drip, which sprays the oil on the flange. An asphaltum oil that contains no grease should be used; a greasy oil will tend to spread over the top of the rail and the tread of the driver, causing the locomotive to slip.

For Mallet engines the nozzles should be applied to the back of the front driving wheels on both high and low pressure units. When this type of engine is used in switching service two of the four feed oilers should be used and the nozzles applied to the back of the front drivers and to the front of the back drivers of

both the low and high pressure engine units. For switching engines the nozzles should be applied to the back of the front driver and to the front of the back driver on both sides of the engine. Care should be taken to see that the nozzles are maintained in their proper location, so that the oil will be properly sprayed on the flange and not on the tread of the wheel. The oiler is provided with valves and passages whereby it may be thoroughly cleaned with live steam from the boiler, and in order to obtain the best service it should be maintained in a clean condition at all times.

### SAFETY FIRE QUENCHER FOR BLACKSMITH SHOPS

A device for quenching forge fires in the blacksmith shop, designed to eliminate the danger of scalding arising from the sudden application of a large quantity of water to a hot fire, has been developed by A. W. McCaslin, master blacksmith of the McKees Rocks shop of the Pittsburgh & Lake Erie. Mr. McCaslin is the inventor of an improved type of blacksmith forge which is now used by a number of railroads and in the illustration the safety quenching device is shown applied to one of these forges.

Water is supplied to each double forge from a pan located



Safety Device for Quenching Forge Fires

between the backs of the two fires by pipes extending through the back walls. Each pipe terminates in a nipple over which a 2 ft length of 1/4 in. perforated pipe may be slipped when it is desired to quench the fire. By opening a valve at the side of the forge a spray of water is delivered from the pan which gradually quenches the fire without the formation of more steam than can be accommodated by the uptake. When not in use the perforated pipe is removed. This device not only eliminates all danger to the men of being scalded by

throwing large volumes of water upon the fire, but gives the slack coal a better chance to cake and leaves the fuel in much better condition for future service. The water pan is fed from the water line running through the shop, the only attention required being to turn off the water when the pan is filled.

### PORTABLE CRANE WITH BACK GEAR

A portable floor crane and hoist which has found considerable application in railroad shops was described in the October, 1913, issue of the *Railway Age Gazette, Mechanical Edition*, page 568. This crane is manufactured by the Canton Foundry & Machine Company, and is designed for handling work not exceeding 3,000 lb. in weight. Where weights greater than this are

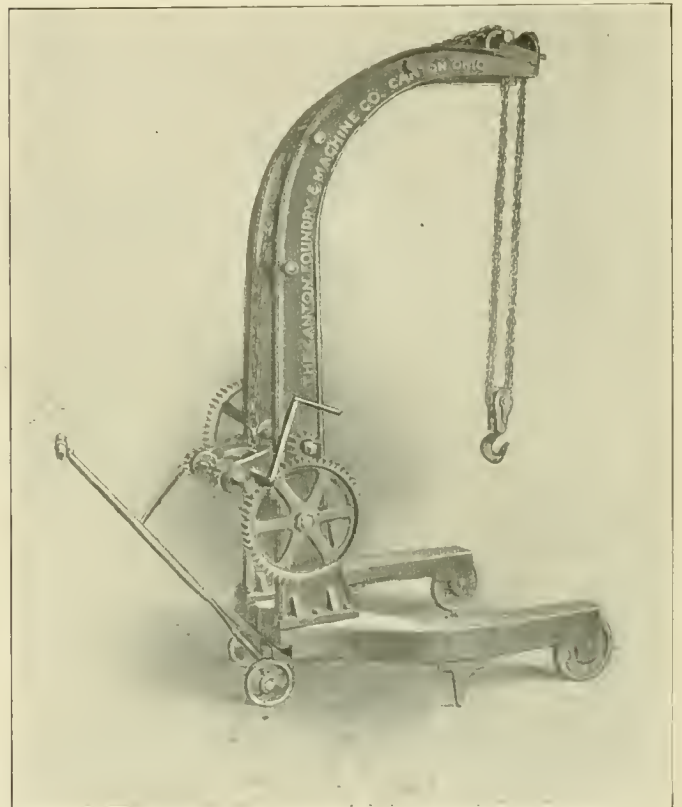

Portable Crane and Hoist Equipped with Back Gear

required to be lifted it is usually impossible for one man to do the work alone. In order to provide for work heavier than 3,000 lb. and ranging as high as 5,000 to 6,000 lb. the crane has been redesigned to include a back gear, thus enabling it to be handled by one man without assistance. The back gear crane has a total height of 8 ft. 9 in., and will lift up to 7 ft. 6 in. It weighs 1,400 lb., and has a capacity of 6,500 lb.

### MOTOR DRIVEN SLOTTING MACHINE

The slotting machine shown in the illustration has been developed recently by the Newton Machine Tool Works, Inc., Philadelphia, Pa.\* It is particularly adapted to slotting open end rods, finishing brasses and other similar work and is equipped with a type of gear box transmission especially suited to the use of alternating current motors.

A noteworthy feature of the design is the location of the speed change gear box within the upright of the machine whence it may be removed to facilitate repairs or replacements. The different speed combinations, six in number, are controlled through the latch levers shown on the side of the upright, which operate



sliding sleeves on which the several groups of gears are mounted. The arrangement is such that the lower train of gears revolves continuously in an oil bath, thus insuring efficient lubrication.

The machine is driven by a 10 hp. motor which is attached to one side of the upright, motion being transmitted through spur gears to the large plate gear shown at the back of the machine and thence to the cutter bar through a crank disc arranged to give a quick return stroke. All dangerously exposed gears are covered with meshed guards which are not shown in the illustration.

The cutter bar, which is of heavy box construction, carries a tool apron designed to relieve the tool or to be fixed as desired, and which has vertical and horizontal steel faced clamping surfaces. The bar has square lock bearings in the guide and a continuous taper shoe for side adjustment. The vertical adjusting screw is relieved of strain when cutting by means of a serrated clamping surface on the front face of the bar. The adjusting screw is operated by means of a square shaft projecting from the face of the bar. The cutter bar guide has square lock bearings

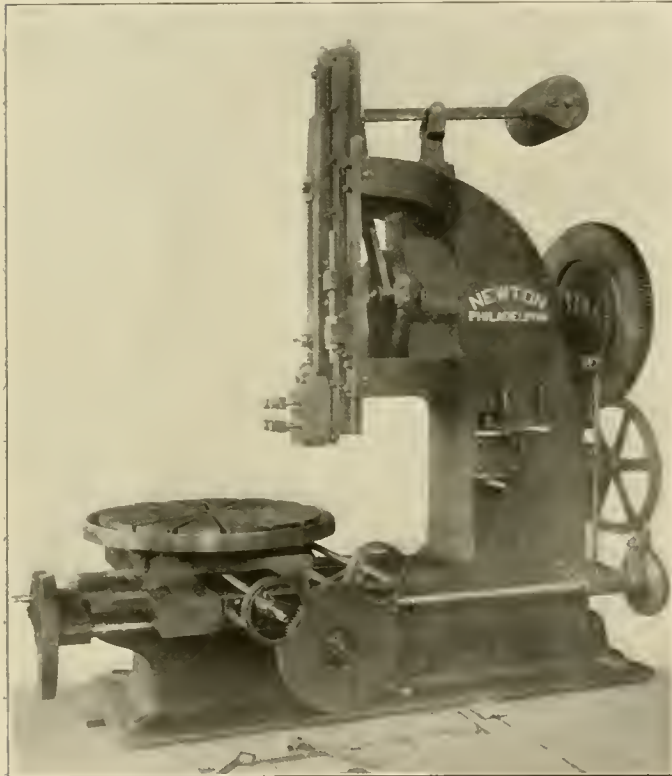

Slotting Machine With Inside Speed Box

in the frame and is adjusted vertically to suit the location of the bar by means of a hand screw shown in the illustration. The cutter bar yoke has a bearing on each side of the connecting rod thus supporting the pin in double shear, and the stroke adjusting screw is relieved of strain by tongues on the connecting rod washer which engage grooves in the face of the crank pin.

The work table is surrounded by an oil pan forming an integral part of the casting, the periphery of which is graduated in degrees. The horizontal adjustment of the saddle on the cross slide and of the cross slide on the base are made by means of taper shoes. Power feed connections are provided for all motions of the table, including the circular motion of the table itself, as well as the in-and-out and cross movement of the saddle and cross slide respectively. For ordinary requirements the machine is designed to give a range of cutting strokes varying from 8 to 40 strokes per minute, but where desired the limits of the range may be altered, the ratio, however, remaining the same.

## GRAPHITE LUBRICATOR

The Graphite Lubricator Company, Detroit, Mich., has placed on the market a graphite lubricator for lubricating with flake graphite the valves and cylinders of locomotives. This graphite is suspended in common engine oil for the purpose of more easily filling the lubricator. The device is used in connection with the oil lubricator as now in use on locomotives. The present oil lubricator acts as the cleaner, while the graphite lubricator delivers graphite to the cylinders and valves as the lubricant. The accompanying illustration clearly shows its construction. The oil line from the steam or gravity-feed lubricator in the cab is connected to the top of the graphite lubricator, and the oil and steam pass to the cylinder and valves through the nozzle shown on the inside. The graphite is contained in the annular space surrounding this nozzle, and the feed is controlled by means of the regulating valve, as shown. The pulsating pressure of the steam will cause the feeding of the graphite through the passage controlled by the regulating valve, and there it becomes mixed with the oil from the gravity-feed lubricator. It is then distributed to the various parts of the valves and cylinders.

This lubricator is adapted for use on superheater and compound locomotives (either piston or slide valve type) and especially those engines which experience trouble in obtaining the

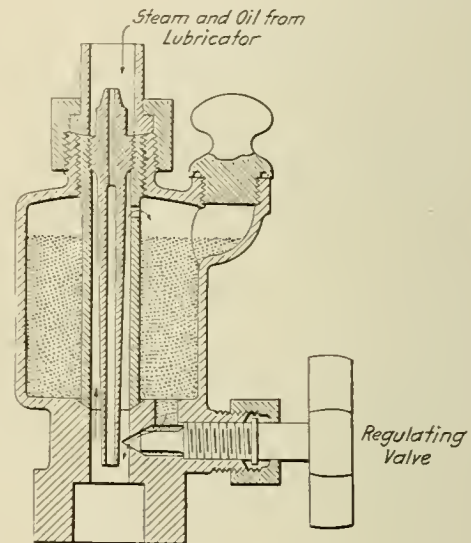

Cylinder Lubricator for Flake Graphite

proper lubrication of the valves and cylinders. It is claimed that the priming of locomotives will not in any way interfere with the proper lubrication of the cylinders and valves where this lubricator is used. It is also claimed that 50 per cent less cylinder oil will be required for lubrication in the cylinders and valves, and that at the same time a better lubrication will be obtained by the use of the flake graphite.

The lubricator shown, which will hold three ounces of the graphite lubricating mixture, is filled through the plug shown at the top and to the right of the lubricator. It may be attached to any standard steam chest choke-plug fitting, and thus eliminates the use of the choke plugs. One filling of the model A three-ounce lubricator is sufficient for the operation of a locomotive for approximately 250 miles without further attention on the part of the crew. At present the lubricators are made in two sizes—model A, which holds three ounces of lubricant, and model B, which holds six ounces.

GERMAN CANAL LOCKS.—The locks of the Kaiser Wilhelm Canal in Germany, which is playing an important part in the naval strategy of the present war, are the largest in the world, being 72 ft. longer and 38 ft. wider than the locks of the Panama Canal.—*Machinery.*

# NEWS DEPARTMENT

The Boylston street subway, in Boston, which has been under construction for the past two years, was opened for traffic October 3. This subway is about 1½ miles long, extending from the north-and-south subway near the Public Garden westward toward Brookline.

The Delaware, Lackawanna & Western has finished, at Hoboken, N. J., as a part of its wireless telegraph equipment, a steel tower, 402 ft. high. The Hoboken office now has a five kilowatt Marconi apparatus, and messages have been sent from Hoboken to Buffalo, 410 miles. The wave length is 2,250 meters.

The Interstate Commerce Commission has postponed to March 31, 1915, the date on which carriers must have complied with its order under the transportation-of-explosives act, requiring gas cylinders to be supplied with certain safety devices. Owners of such cylinders placed orders in Europe for the required devices, but now have informed the commission that their orders cannot be filled within the time limit fixed.

A recent statement issued by the New York Public Service Commission, First district, reports that the total number of tickets sold for passage in the Broadway and Lenox avenue subways operated by the Interborough Rapid Transit Company during the year ended June 30, 1914, was 340,413,103, an increase for the year of 12,941,593. As the commission treats Sundays as half days, the daily average for the first time in the history of the subway exceeds 1,000,000 passengers, the average having been 1,001,215. The daily average for the previous year was 963,152.

At a recent meeting of the Illinois legislative committee of the Brotherhood of Locomotive Firemen and Enginemen at Springfield, it was decided to advocate a change in the federal hours of service law, to reduce the maximum hours of trainmen from 16 to 10 hours a day. Other legislation is to be advocated which would provide for a limitation on the number of cars in a train, a uniform code of signals, giving trainmen a right to vote when they are away from home on election day, standardization of overhead and side clearances, and giving the Interstate Commerce Commission power to specify the type of steel cars to be used in passenger trains.

The management of the Pennsylvania Railroad has begun a campaign to keep passengers from standing on the platforms of moving passenger cars. Letters have been sent to the various industries around Pittsburgh, requesting them to post notices in their factories warning their employees (hundreds of whom ride on Pennsylvania trains daily, going to and from their work) of the danger of standing on the platforms of moving cars; and a general notice to passenger trainmen has been posted on the bulletin boards calling for a concerted effort on the part of trainmen to keep passengers from riding on platforms or steps of cars between or approaching stations.

Representative Rupley, of Pennsylvania, has introduced in Congress a bill to amend the interstate commerce law, providing that after the physical valuation of the railroads has been completed by the Interstate Commerce Commission the government may buy such lines at the price set as the actual value of the roads, as may in the opinion of the commission be desirable, and that if at the expiration of 90 days from the offer to the railroads the companies decline to sell, the government may enter the open market to buy such securities as may be necessary to obtain control. The price to be paid, however, must not exceed that set by the physical valuation. An initial appropriation of \$250,000,000 would be provided by a bond issue.

## EVENING ENGINEERING COURSES AT UNIVERSITY OF PITTSBURGH

An evening school of graduate courses in engineering will be a new feature introduced at the University of Pittsburgh this fall by the Dean, F. L. Bishop. It is stated that in the Pittsburgh district there are more engineering graduates than in any other district of equal size in the United States, and the University will provide for men who do engineering work during the day an opportunity to study engineering in the evening. Courses will be offered in the valuation of public utilities, civil, electrical, sanitary, mechanical, railway and concrete engineering. The faculty will include Paul M. Lincoln, professor of electrical engineering; Louis E. Endsley, professor of railway engineering; R. T. Stewart, head of the department of mechanical engineering; J. Hammond Smith, head of the department of civil engineering, and Morris Knowles, director of the department of sanitary engineering, all of the University of Pittsburgh. Professor G. W. Case and William S. Moorehead will also assist in the course in the valuation of public utilities, and D. F. Crawford, general superintendent of motive power of the Pennsylvania Lines West of Pittsburgh, will co-operate with Professor Endsley in the work of mechanical railway engineering.

## TWELVE-TON PACIFIC TYPE LOCOMOTIVES

The Panama-Pacific International Exposition at San Francisco next year is to have on the grounds a steam passenger railroad. Electricity is not absolutely supreme and all-pervasive. However, the track is to be of 19-in. gage and the locomotives are only 17 ft. long. As in the case of the Centennial Exposition at Philadelphia in 1876, the little railroad is designed not only to ride over but also to be looked at. There will be 2½ miles of road and 5 miles of track, work on which has just been begun. There will be eight or ten Pacific type locomotives equipped with air brakes, standard couplers and electric headlights. Each little giant will haul a train of ten miniature passenger coaches, and running on regular schedules on a double-track system. Each of the coaches, with a width of 42 in. and a length of 20 ft., will contain ten transverse seats, and will seat twenty passengers. With ten coaches to each train and eight trains in operation, 1,600 people can be put in motion at once.

The route, commencing at the terminal at the southeast corner of the Palace of Machinery, will be northerly across the plaza of the exposition ferry slips, to the water front, thence west along the Marina, around three sides of the Yacht Harbor, diagonally across the gardens of the California building, and thence by way of the bayshore and the many state buildings to the race track. The main loading station, at the beginning of the line at the Machinery Palace, will be 300 ft. in length, with five tracks; between which will be elevated loading platforms. The entire line will be double tracked, with rails weighing 39 lb. per yard.

## A SAFETY-FIRST MOTION-PICTURE PLAY

Marcus A. Dow, general safety agent of the New York Central Lines, has recently had produced a rather remarkable motion-picture play entitled "Steve Hill's Awakening" for use in connection with the safety-first work now being conducted by the New York Central. The picture, a brief description of which is given below, is one of the first produced under railroad auspices for this purpose, telling a story of human interest with its principal parts played by professional actors. The scheme was carried out with the idea of departing from stereotyped methods, Mr. Dow, who some time ago introduced the safety exhibit car on the New York Central Lines (Railway Age Gazette, August 8,



1913, p. 228), having seen the necessity of introducing a feature that would create sufficient interest among the employees to bring them into the safety meetings willingly. And, of course, a "human interest" story will leave on their minds a more lasting impression than the ordinary didactic lecture. It is the intention of the company to show the "movie" in a specially equipped car, to be run over all of the Central lines, as has been done with the safety exhibit cars, stopping at the principal points. The pictures will also be used at large safety meetings conducted in halls or theaters in the various cities on the line.

The story is in brief as follows:

Henry Hill, a trainman, at the end of his run, coming in to the yard and jumping off the caboose, starts, against the advice of a fellow employee, to take a short cut along the tracks to his home, and is struck by an engine and killed, leaving a widow and two children, a boy and a girl. Soon after this the family is dispossessed, the widow later dies in poverty and the two children are sent to an orphan asylum. Fifteen years later, the son, Steve Hill, becomes a brakeman in the yard where his father was killed. He is of careless habits and is shown on the screen taking the usual risks, such as kicking a drawbar with his foot and jumping on the front of a moving yard engine. For this conduct he is reproved by the yardmaster, Jack Warren. The "human interest" of the story comes in when "Steve" meets Mary, the yardmaster's daughter, and courts her. The father's consent to marriage is withheld because of Steve's careless habits in his work. Steve, nevertheless, does not take the lesson to heart, and a short time after, disregarding a blue flag, he causes a slight collision on a repair track, and knocks a car body off its supporting horses, thereby causing serious injury to a car repairer. He is then discharged, at once; and is also repudiated by Mary. Going home in a disconsolate mood, he throws himself on his bed, falls asleep and has a dream, in which he sees himself taking all sorts of chances. For instance, he crosses the track between two cars and barely escapes being crushed. He is hurled from a side ladder by a car which stands out beyond the fouling point. Walking across a track without looking where he is going, he is almost run over by an engine. Finally, however, he takes one chance too many and loses his leg. He awakes from his dream with a start, overjoyed, to be sure, to find that his leg is not gone; but taught a lesson that makes him begin anew with "Safety First" as his motto. He is reinstated in his job, and marries the girl. The scene then passes to thirty years later showing him and his wife, both gray haired, in their happy home. "Steve" is telling a party of friends that his policy of Safety-First has made him a successful railroad man.

The picture is in two reels, and takes about half an hour to show. It is well done, and is to be classed as better than the average. Mr. Dow says that the Atchison, Topeka & Santa Fe; the Chicago, Burlington & Quincy, and the Delaware, Lackawanna & Western have made arrangements to use the film.

### MEETINGS AND CONVENTIONS

*Car Foremen's Association of Chicago.*—The Car Foremen's Association of Chicago held its annual meeting in Chicago, October 13, 1914, at which time the following officers were elected:

President, C. J. Wymer, general car foreman, Belt Railway, Chicago; first vice-president, A. LaMar, master mechanic, Pennsylvania Railroad, Chicago; second vice-president, A. L. Beardsley, master mechanic, Atchison, Topeka & Santa Fe, Chicago; treasurer, M. F. Covert, assistant master car builder, Swift & Company, Chicago; secretary, Aaron Kline, 841 North Lawler avenue, Chicago.

*American Society of Mechanical Engineers.*—The annual convention of the American Society of Mechanical Engineers will be held in the Engineering Societies building, 29 West 39th street, New York, December 1 to 4, 1914. The railroad session will be held on Wednesday afternoon, December 2, when the report of the sub-committee will be presented and thrown open for discussion. The subject is Steam Locomotives of Today and it is hoped that the paper prepared by the committee will be the means of bringing out a lively discussion. This paper is printed in full elsewhere in this issue.

*The June Conventions.*—At a meeting of the executive committees of the American Railway Master Mechanics' Association, the Master Car Builders' Association and the Railway Supply Manufacturers' Association, held at the Hotel Biltmore, New York, on October 22, it was decided to hold the 1915 convention at Atlantic City, N. J. The cities of Washington, Chicago, San Francisco and Atlantic City were under consideration for next year's meeting, and the decision was made only after much discussion and on a very close vote. It is announced that the convention hall will be further enlarged about one-third for the meetings and that the entertainment features will be about the same as in 1914. Headquarters, as before, will be at the Marlborough Blenheim.

The following list gives names of secretaries, dates of next or regular meetings, and places of meeting of mechanical associations.

- AIR BRAKE ASSOCIATION.—F. M. Nellis, 53 State St., Boston, Mass. Convention, May 5-7, 1915, Hotel Sherman, Chicago.
- AMERICAN RAILWAY MASTER MECHANICS' ASSOCIATION.—J. W. Taylor, Karpen building, Chicago. Convention, June, 1915, Atlantic City, N. J.
- AMERICAN RAILWAY TOOL FOREMEN'S ASSOCIATION.—Owen D. Kinsey, Illinois Central, Chicago. Convention, July, 1915, Chicago.
- AMERICAN SOCIETY FOR TESTING MATERIALS.—Prof. E. Marburg, University of Pennsylvania, Philadelphia, Pa.
- AMERICAN SOCIETY OF MECHANICAL ENGINEERS.—Calvin W. Rice, 29 W. Thirty-ninth street, New York. Convention, December 1-4, 1914, New York.
- CAR FOREMEN'S ASSOCIATION OF CHICAGO.—Aaron Kline, 841 North Fiftieth Court, Chicago; 2d Monday in month, except July and August, Lytton building, Chicago.
- CHIEF INTERCHANGE CAR INSPECTORS' AND CAR FOREMEN'S ASSOCIATION.—S. Skidmore, 946 Richmond street, Cincinnati, Ohio.
- INTERNATIONAL RAILWAY FUEL ASSOCIATION.—C. G. Hall, 922 McCormick building, Chicago. Convention, May 17-20, 1915, Chicago.
- INTERNATIONAL RAILWAY GENERAL FOREMEN'S ASSOCIATION.—William Hall, 914 W. Broadway, Winona, Minn. Convention, July, 1915.
- INTERNATIONAL RAILROAD MASTER BLACKSMITHS' ASSOCIATION.—A. L. Woodworth, Lima, Ohio.
- MASTER BOILER MAKERS' ASSOCIATION.—Harry D. Vought, 95 Liberty street, New York.
- MASTER CAR BUILDERS' ASSOCIATION.—J. W. Taylor, Karpen building, Chicago. Convention, June, 1915, Atlantic City, N. J.
- MASTER CAR AND LOCOMOTIVE PAINTERS' ASSOC. OF U. S. AND CANADA.—A. P. Dane, B. & M., Reading, Mass.
- NIAGARA FRONTIER CAR MEN'S ASSOCIATION.—E. Frankenberger, 623 Brisbane building, Buffalo, N. Y. Meetings monthly.
- RAILWAY STOREKEEPERS' ASSOCIATION.—J. P. Murphy, Box C, Collinwood, Ohio. Convention, May 17-19, 1915, Hotel Sherman, Chicago.
- TRAVELING ENGINEERS' ASSOCIATION.—W. O. Thompson, N. Y. C. & H. R., East Buffalo, N. Y.

### RAILROAD CLUB MEETINGS

Club	Next Meeting	Title of Paper	Author	Secretary	Address
Canadian .....	Nov. 10	Characteristics of Materials.....	E. B. Tilt.....	James Powell....	Room 13, Windsor Hotel, Montreal.
Central .....	Nov. 13	Painting Locomotives and Steel Cars.....	M. L. Sims.....	H. D. Vought....	95 Liberty St., New York City.
New England....	Nov. 10	Typical Rail Failures.....	F. A. Weymouth....	Wm. Cade, Jr....	683 Atlantic Ave., Boston, Mass.
New York.....	Nov. 20	Parcels Post and Its Effect on Railway			
Pittsburgh .....	Nov. 27	Revenues .....	V. J. Bradley.....	H. D. Vought....	95 Liberty St., New York City.
		Rolled Steel Pistons.....	W. W. Scott.....	J. B. Anderson..	207 Penn. Station, Pittsburgh, Pa.
Richmond .....	Nov. 9	The Average Man in Railroad Work.....	Odell S. Smith....	F. O. Robinson..	C. & O. Ry., Richmond, Va.
St. Louis.....	Nov. 13	Railway Pensions .....	J. B. Brittan.....	B. W. Frauenthal.	Union Station, St. Louis, Mo.
Southern & S'w'n	Nov. 19			A. J. Merril.....	218 Grant Bldg., Atlanta, Ga.
Western .....	Nov. 17			Jos. W. Taylor....	1112 Karpen Bldg., Chicago, Ill.

## PERSONALS

*It is our desire to make these columns cover as completely as possible all the changes that take place in the mechanical departments of the railways of this country, and we shall greatly appreciate any assistance that our readers may give us in helping to bring this about.*

### GENERAL

JOSEPH BILLINGHAM, whose appointment as superintendent of motive power of the Grand Trunk Pacific, with headquarters at Transcona, Man., has already been announced in these columns, began railway work as machinist apprentice on the Great Northern Railway of England, and subsequently was a machinist in the shops of the Chicago & North Western. He served later as a locomotive engineer and road foreman of engines on the Chicago, Milwaukee & St. Paul. In December, 1890, he was appointed road foreman of engines of the Gulf, Colorado & Santa Fe. He was subsequently master mechanic and general master mechanic on the same road, and division master mechanic on the Baltimore & Ohio. In January, 1904, he was appointed representative of the Galena Signal Oil Company at London, Eng., and at the time of his recent appointment as superintendent of motive power of the Grand Trunk Pacific, was general inspector of the American Locomotive Company at Schenectady, N. Y.

### MASTER MECHANICS AND ROAD FOREMEN OF ENGINES

G. F. BURGESS, formerly road foreman of engines of the Canadian Pacific at McLeod, Alta., and later acting district master mechanic at Cranbrook, B. C., during the absence of G. Glasford on leave, has been appointed road foreman of engines at Medicine Hat, Alta., succeeding E. J. Lemieux.

T. C. HUDSON, whose appointment as division master mechanic of the Canadian Northern, Quebec Grand division, has been announced in these columns, was born February 20, 1873, at

Brockville, Ont. He was educated in the public schools of Brockville and Carleton Place, Ont., and also studied with the International Correspondence Schools. He completed his apprenticeship as machinist with the Canadian Pacific at Carleton Place, Ont., in January, 1892, since which he has been consecutively machinist at that point, at Chapeau, Ont., and again at Carleton Place. From September, 1901, to April, 1903, he was chageman in the running shed of the Canadian Pacific at Smiths Falls, Ont., and from

April, 1903, to November, 1904, he was chageman in the erecting shop at Carleton Place. From November, 1904, to January, 1906, he was foreman of the erecting shop at Carleton Place, and from January, 1906, to December, 1906, was locomotive foreman of the same road at Ottawa, Ont. From January, 1907, to August, 1907, he was foreman of the Canadian Northern Ontario at Parry Sound, and from August, 1907, to May, 1908, he held the position of master mechanic of the Canadian Northern Quebec at Shawinigan Junction, Que. From May, 1908, to June, 1914, he was master mechanic of that road and also the Quebec & Lake

St. John. On June 23, 1914, he was appointed division master mechanic of the Quebec Grand division of the Canadian Northern, Lines East of Ottawa, as above noted.

J. R. DONNELLY, master mechanic of the Northern division of the Grand Trunk at Allandale, Ont., has been appointed assistant master mechanic of the Ontario lines, with headquarters at Allandale and the title of master mechanic of the Northern division has been abolished.

HARRY M. M'CHMORE has been appointed division foreman of the Atchison, Topeka & Santa Fe at Deming, N. M., succeeding L. Stowell.

E. J. LEMIEUX, formerly road foreman of engines of the Canadian Pacific at Medicine Hat, Alta., has been appointed district master mechanic at Lethbridge, Alta.

J. MARKEY, master mechanic of the Middle division of the Grand Trunk at Toronto, Ont., has been appointed master mechanic of the Ontario lines, with headquarters at Toronto.

T. MCHATTIE, master mechanic of the Eastern division of the Grand Trunk at Montreal, Que., has been appointed master mechanic of the Eastern lines, with headquarters at Montreal.

W. H. SAMPLE, master mechanic of the Grand Trunk at Ottawa, Ont., has been appointed master mechanic of the Western lines, with headquarters at Battle Creek, Mich., succeeding G. Vliet, deceased, and the title of master mechanic of the Ottawa division has been abolished.

W. H. SNYDER, whose appointment as master mechanic of the Erie with headquarters at Stroudsburg, Pa., has been announced in these columns, was born on July 14, 1874, at Ashley, Luzerne



W. H. Snyder

County, Pa. He began railway work on March 18, 1894, as machinist apprentice in the Central of New Jersey shops at Ashley, remaining with that road until July, 1901, when he went to Stroudsburg as a machinist in the Erie shops. In October, 1903, he was promoted to tool room foreman, and in November, 1905, was appointed assistant to general foreman. He remained in that position until January, 1912, when he was promoted to general foreman which position he held at the time of his appointment on September 1, as master mechanic

of the same road as above noted. He was the successful contributor in several competitions conducted by the Railway Age Gazette.

J. H. WOOD has been appointed supervisor of locomotive operation of the Oklahoma and Panhandle divisions of the Rock Island Lines, with headquarters at El Reno, Okla., succeeding C. S. Yeaton, transferred.

C. S. YEATON, supervisor of locomotive operation of the Chicago, Rock Island & Pacific at El Reno, Okla., has been appointed road foreman of equipment at that place, succeeding O. F. Covalt, assigned to other duties.

### CAR DEPARTMENT

WILLIAM R. MCMUNN has been appointed general car inspector of the New York Central & Hudson River, with headquarters at Albany, N. Y., succeeding F. W. Chaffee, deceased.



O. E. SHAW has been appointed general car foreman of the Chicago & Eastern Illinois at Danville, Ill. He started railroad work in 1901 with the Merchant's Dispatch Transportation Company at East Rochester, N. Y. From 1901 to 1909 he was engaged as a car builder in a number of shops and on all classes of freight car work. In 1909 he entered the service of the Atchison, Topeka & Santa Fe as an inspector at Cleburne, Tex., and was later appointed assistant car foreman at that point. In April, 1913, he entered the service of the Chicago & Eastern Illinois as car foreman at Villa Grove, Ill., and during the same year was transferred to the Oaklawn shop at Danville, Ill., as car foreman, the position which he held at the time of his appointment as general car foreman as above noted.

#### SHOP AND ENGINE HOUSE

J. L. CONNORS has been appointed roundhouse foreman of the Erie at Ferrona, Pa.

J. E. DAVIDSON has been appointed night roundhouse foreman of the Erie at Cleveland, Ohio.

R. GARDNER has been appointed locomotive foreman of the Grand Trunk at Island Pond, Vt.

J. F. GREEN has been appointed night roundhouse foreman of the Rock Island Lines at Rock Island, Ill., succeeding H. Krabenhof.

W. E. HAYWARD, formerly roundhouse foreman of the Canadian Pacific at Vancouver, B. C., has been appointed night roundhouse foreman at Alyth, Calgary, Alta.

FRANK MAHER has been appointed roundhouse foreman of the Rock Island Lines at Biddle, Ark., succeeding L. Cooke.

T. McCUE has been appointed roundhouse foreman of the Erie at Cleveland, Ohio, succeeding F. D. McCullough, resigned.

#### PURCHASING AND STOREKEEPING

S. H. ROBSON, supply agent of the Northern Pacific at South Tacoma, Wash., has been appointed assistant general storekeeper at that place.

O. C. WAKEFIELD, supply agent of the Northern Pacific at St. Paul, Minn., has been appointed general storekeeper, in charge of materials and supplies, with headquarters at St. Paul.

C. B. WILLIAMS, whose appointment as purchasing agent of the Central of New Jersey, with headquarters at New York City, has been announced in these columns, was born on March 22, 1873, at Beech Creek, Pa., and after leaving the common schools was a student at the Pennsylvania State College for a short time. In 1890, he was graduated from Eastman Business College and in July of the following year began railway work with the Beech Creek Railroad, now a part of the Pennsylvania division of the New York Central & Hudson River. He entered the service of the Central of New Jersey on November 27, 1893, as stenographer and chief clerk to the general superintendent. From February, 1900, until September, 1908, he was chief clerk to the superintendent of motive power and then was appointed general storekeeper, which position he held at the time of his recent appointment as purchasing agent of the same road, as above noted.

#### I. C. C. APPOINTMENTS

A. J. CUNNINGHAM, general foreman of the Atchison, Topeka & Santa Fe at Barstow, Cal., has been appointed inspector of motive power for the Pacific district, division of valuation, Interstate Commerce Commission, with headquarters at San Francisco, Cal.

W. J. THOMAS has been appointed inspector of car equipment for the Pacific district, division of valuation, Interstate Commerce Commission, with headquarters at San Francisco, Cal. Mr. Thomas recently has been employed in the United States Interior Department, and formerly was in railway service.

#### OBITUARY

CHARLES J. DRURY, master mechanic of the St. Louis & San Francisco at Sapulpa, Okla., died on September 30, at the age of 36. He was born at Chicago Junction, Ohio, and began railway work in July, 1895, as machinist apprentice for the Atchison, Topeka & Santa Fe. After completing his apprenticeship in July, 1899, he was employed as machinist for that road, the Southern Pacific, the Kansas City Southern, the El Paso & Southwestern, the Chicago, Rock Island & Pacific and other roads for seven years, becoming roundhouse foreman for the Santa Fe at La Junta, Colo., in July, 1906. He remained with the Santa Fe until February, 1913, filling the positions of general foreman at Albuquerque, N. M.; bonus supervisor of the Western Grand division; master mechanic of the Oklahoma division at Arkansas City, Kan., and master mechanic of the Plains division at Amarillo, Tex. He then became master mechanic of the St. Louis & San Francisco at Ft. Smith, Ark., and the following February was appointed superintendent of shops at Springfield, Mo. Mr. Drury was promoted to division master mechanic at Sapulpa, Okla., on September 1, just prior to his illness of typhoid fever, from which he died on September 30. Mr. Drury's father, M. J. Drury, is superintendent of shops of the Santa Fe at Topeka, Kan.

E. B. GILBERT, formerly superintendent of motive power of the Bessemer & Lake Erie, died at his home in Greenville, Pa., on September 7. Mr. Gilbert was born at Windsor, N. Y., on December 13, 1843. He took up the trade of machinist, and later was employed on the Erie Railroad, both at Youngstown, Ohio, and at Galion, in the latter place holding the position of foreman. He went to Greenville about 28 years ago, and entered the service of the Pittsburg, Shenango & Lake Erie, now the Bessemer & Lake Erie. He was promoted from machinist foreman to master mechanic, and later to superintendent of motive power, which position he held until his resignation in 1909.

J. P. McCUEN, formerly superintendent of motive power of the Queen & Crescent Route, died at his home in Avondale, Cincinnati, O., on October 2, aged 70 years. He was connected with the mechanical department of that system for 30 years, retiring about three years ago.

#### NEW SHOPS

ATLANTIC COAST LINE.—Work is now under way, it is said, on the foundations for an addition to the machine shops at Waycross, Ga.

LOUISVILLE & NASHVILLE.—A building permit has been issued to the Louisville & Nashville for the construction of a 12-stall roundhouse and repair shops in the yard at Lexington, Ky., and work on these improvements is now under way.

AUTOMATIC COUPLERS IN EUROPE.—As far back as 1896, the introduction of automatic couplings was demanded on humanitarian grounds by medical men. Laws were passed in the United States making the adoption of automatic couplings compulsory; and quite recently a similar law has been passed in the Argentine Republic. It is proposed to do the same thing in Brazil. In Europe, the International Union for the legal protection of workmen passed a resolution in favor of the introduction of automatic couplings at its 1908 meeting in Lausanne. Mr. Millerand, the French minister of works and railways, endorsed this resolution in his capacity of president of the French section of the union. The technical committee of the German Verein strongly recommended, in 1900, the introduction of automatic couplings, and expressed the opinion that the technical and economic difficulties were by no means insuperable.—*Bulletin of the International Railway Congress.*

## SUPPLY TRADE NOTES

Spencer Van Cleve, president of the Erie Foundry Company, died on September 29.

T. B. Van Dorn, first vice-president of the Van Dorn Iron Works Company, Cleveland, Ohio, has been elected president of the company, succeeding his father, J. H. Van Dorn, who died recently.

Charles Hyland, for many years foreman boilermaker in the Jackson, Mich., shops of the Michigan Central, has resigned to accept the position of boiler expert with the Flannery Bolt Company, Pittsburgh, Pa., succeeding Tom R. Davis, deceased.

The Monarch Steel Castings Company, Detroit, Mich., announces the opening of an exhibit of Lion and Monarch couplers, Lion coupler pockets for locomotives and Lion cast steel yokes in the office of H. F. Wardwell, their Chicago representative at 548 Railway Exchange, Chicago.

At the annual meeting of the American Locomotive Company in New York on October 20, retiring directors W. H. Marshall, A. H. Wiggin and A. W. Mellon were re-elected to serve for three years. The present officers of the company were likewise re-elected to serve for the following year.

The Q & C Company, New York, has taken over the exclusive license and control of the Ross-Schofield system of water circulation for locomotive boilers for the United States and Canada. C. F. Pierce, who had charge of this work with the Ross-Schofield Company, has gone to the Q & C Company as special representative.

The Independent Pneumatic Tool Company, Chicago, has appointed V. F. Robinson its representative in Michigan, with headquarters at Detroit. F. J. Passino, the former representative in Michigan, has been appointed representative in the southwest to succeed H. F. Finney, promoted to a position in the general sales office at Chicago.

The Buda Company, Chicago, Ill., has taken over the repair link for wrecking chains patented by John E. Buckley, former foreman blacksmith of the Illinois Central. This link is of special advantage in wrecking equipment where chains are often broken, and has been used on the Illinois Central for some time. Tensile tests have shown it to be stronger than the other links of the chain to which it is attached. This device is illustrated in the 1912 edition of the Car Builders' Dictionary on page 881.

John Steele Patterson, for the past 24 years resident manager of the Galena Signal Oil Company, Franklin, Pa., at Cincinnati, Ohio, died at his home in that city on October 13. Mr. Patterson was born in Baltimore, Md., on February 13, 1839. He served his term as machinist's apprentice in the shops of the Baltimore & Ohio at Cumberland, Md., and was later general foreman in the Baltimore & Ohio shops at Portsmouth, Ohio. When he was 24 years of age he was appointed master mechanic of the Cincinnati, Indianapolis, St. Louis & Chicago, now the Big Four, at Cincinnati, and served in that position for 25 years. For the past 24 years he had been connected with the Galena Signal Oil Company as noted above.

Ellis F. Muther, eastern sales manager of the Gisholt Machine Company, Madison, Wis., with headquarters in New York, has been appointed general sales manager of the company, with office at Madison. It is also announced that J. E. Brandt, hitherto representative in Philadelphia and vicinity, has become associated with the Swind Machinery Company, which has been appointed a Gisholt agency in that city. J. L. Osgood has been appointed exclusive agent in Buffalo and Rochester, N. Y. R. D. Heflin, formerly representative of the company in New England, has been placed in charge of the New York office, and will henceforth attend to the interests of Gisholt customers and users in the entire eastern territory.

Charles Moulton Gould, vice-president and treasurer of the Gould Coupler Company and the Gould Storage Battery Company, New York, died at his home at Bayside, Long Island on October 20. Mr. Gould has been associated with the Gould Coupler Company for many years. He was born in Buffalo, N. Y., on September 7, 1873, and received his education in the public schools of that city and in De Veaux College at Niagara Falls. In 1895, shortly after graduation, he entered the plant of the Gould Coupler Company at Depew, N. Y., founded by his father, Charles A. Gould, now the company's president. He served in the works for several years and had a large share in their development and the town of Depew which grew up around them, finally going to the New York office as vice-president and treasurer, as noted above. Mr. Gould was very much interested in yachting, and was a prominent member of the New York Yacht Club and the Manhasset Bay Yacht Club.

Tom R. Davis, mechanical expert of the Flannery Bolt Company, Pittsburgh, Pa., died at his home in Dravosburg, Pa., on October 12, 1914, after a long illness. Mr. Davis was born in Allegheny City, Pa., on July 13, 1854. He was educated in the public schools and began work in 1872 as a machinist apprentice in the shops of the Allegheny Locomotive Works (now the Pittsburgh plant of the American Locomotive Company). In 1875 he became a fireman on the Pittsburgh, Fort Wayne & Chicago and in the following year passed his examination for engineer. In 1877 he became a special salesman for the Crosby Steam Gage & Valve Company, Boston, Mass., but left in 1880 to accept the managership of the Monongahela Mfg. Company at Monongahela City, Pa. In 1883 he returned to the Crosby Steam Gage & Valve Company and remained in its employ until 1893 when he became associated with the Garlock Packing Company at Pittsburgh as special agent. In 1898 he entered the employ of the Homestead Valve Mfg. Company, leaving that company in June, 1904, to become mechanical expert of the Flannery Bolt Company, which position he occupied at the time of his death.

Henry H. Westinghouse, brother of the late George Westinghouse, was elected president of the Westinghouse Air Brake Company at the annual meeting on October 15. Mr. Westing-

house has been associated with the company for over 40 years. He was born at Central Bridge, Schoharie county, N. Y., on November 16, 1853. He received his early education at Union High School, Schenectady, graduating in 1870. In 1871 he entered Cornell University to take up the study of mechanical engineering. In 1872 he went to Pittsburgh and became identified with the business of the Westinghouse Air Brake Company. He worked successively in the foundry, machine shop and drafting room, and occupied the positions of general



H. H. Westinghouse

agent, general manager, vice-president and acting president. He was also one of the founders of the firm of Westinghouse Church Kerr & Company, and for many years was the guiding spirit in its management. Mr. Westinghouse is a man of quiet tastes and unostentatious manner. He is a member of the Grolier, Century, Engineers' and Cornell clubs of New York, and the American Society of Mechanical Engineers.



## CATALOGS

**CONDUIT BOXES.**—Pamphlet No. 442, recently issued by the Sprague Electric Works, 527-531 West Thirty-fourth street, New York, is devoted to the line of conduit boxes, outlet, switch boxes and fittings furnished by this company. It is in catalog form and contains 40 pages of specifications and price lists.

**JACKS.**—Bulletin No. 177 of the Buda Company, Chicago, is a four page pamphlet devoted to mine jacks manufactured by this company. The pamphlet contains price lists and illustrations of the various parts of these jacks, which are of more substantial construction than the usual jacks of similar type and capacity.

**POWER PLANT INSTRUMENTS.**—A 32 page pamphlet has recently been issued by Lewis M. Ellison, 6238 Princeton avenue, Chicago, which is devoted to power plant instruments, including a line of differential draft gages, gas pressure gages and fittings. The Ellison throttling-evaporating calorimeter is also described.

**RUST RESISTING IRON.**—A 32 page booklet recently issued by the American Rolling Mill Company, Middletown, Ohio, contains facsimile copies of letters received from large numbers of users of Armco-American ingot iron showing the high esteem in which the corrosion resisting qualities of this material are held.

**PORTABLE FLOOR CRANE.**—The Canton Foundry & Machine Company, Canton, Ohio, has recently issued a leaflet briefly describing the No. 4½ Canton back geared portable floor crane and hoist. This crane is designed to lift loads up to 6,000 lb., the back gear being provided to enable one man to lift such loads without assistance.

**MINE HOIST EQUIPMENT.**—The General Electric Company, Schenectady, N. Y., has just issued bulletin No. 48014, which deals with mine hoist equipment. It treats of the general subject of underground hoists, their operation and control, taking up the question of economy of electric drives. It contains 32 pages and is profusely illustrated.

**OVERHEAD TRAMRAIL EQUIPMENT.**—The Whiting Foundry Equipment Company, Harvey, Ill., has just issued catalog No. 111, which is devoted to overhead tramrail equipment. This catalog contains descriptions of a number of monorail trolleys and hand operated hoists especially adapted to foundry use. Copies may be obtained free upon request.

**PNEUMATIC DRILLS.**—A 36 page catalog dealing with the "Little David" pneumatic drill has been issued by the Ingersoll-Rand Company of 11 Broadway, New York. This catalog, which is known as Form No. 8207, contains a description of the construction and operation of the drill, as well as specifications and illustrations of the various sizes manufactured.

**PNEUMATIC HAMMERS.**—The Ingersoll-Rand Company, 11 Broadway, New York, has recently issued a 12 page pamphlet designated as form No. 8013, which is devoted to the "Little David" pneumatic chipping, calking and scaling hammers. It contains illustrations and specifications of hammers for various purposes, as well as sectional drawings showing the mechanism of the hammers.

**PNEUMATIC TOOLS.**—Bulletin 18-A of the Monarch Pneumatic Tool Company, Railway Exchange building, St. Louis, Mo., is a four page leaflet devoted to illustrated descriptions of the Monarch line of pneumatic tools. Tables are given for the various classes of equipment which show the weight, capacity, size of hose connection and other information of value in ordering tools for various classes of work.

**PORTABLE HOISTS.**—Form No. 4033, recently issued by the Ingersoll-Rand Company, 11 Broadway, New York, is an eight page pamphlet devoted to the "Little Tugger" hoist. This is a portable pneumatic hoist specially adapted to use in mines, but

which will find a wide application on construction work, in manufacturing plants and around shops wherever a supply of compressed air is available.

**DIRECT CURRENT TEST METER.**—Bulletin No. 46390, just issued by the General Electric Company, Schenectady, N. Y., describes a Thomson direct current test meter recently developed by this company. The meter which is known as type CB-5 is designed to eliminate the loss of time in changing standards to cover a wide range of load by combining in one standard several capacities covering a range from light to full load.

**FACE HARDENED SPROCKET WHEELS.**—Catalog No. 50 of the Lehigh Car, Wheel & Axle Works, Catasauqua, Pa., is devoted to the line of chilled charcoal iron products of this company. The larger part of the catalog deals with face hardened sprocket wheels, the price list of a large variety of which is given. Other sections are devoted to cement mill and crushing machinery parts. The catalog contains 64 pages and is well illustrated.

**MONORAIL CRANES.**—Bulletin No. 48,700, issued by the Sprague Electric Works, 527-531 West Thirty-fourth street, New York, is devoted to the Sprague line of Monorail cranes. Aside from descriptions of the cranes which are given in considerable detail it contains drawings showing the clearance dimensions and tables giving ratings and weights of the various types of equipment. A number of illustrations showing installations now in operation are included.

**ELECTRIC DRILLS.**—A folder has recently been issued by the Van Dorn Electric Tool Company, Cleveland, Ohio, dealing with the portable electric drills manufactured by this company. This folder contains a phantom drawing showing the internal construction of the drill and gives a brief statement of some of the advantages of electricity over compressed air. As set forth in the folder many of these drills were used in construction work on the Panama Canal.

**INSULATING BRICK.**—The Armstrong Cork & Insulating Company, Pittsburgh, Pa., has recently issued a booklet dealing with the application of Nonpareil insulating brick to boiler settings. The booklet, which contains a number of illustrations, describes the material from which the brick is made, and explains the methods of application. Several photographs are reproduced showing boiler installations which are insulated with this brick.

**STOKERS.**—A 32 page booklet has been issued by the Sanford Riley Stoker Company, Ltd., Worcester, Mass., describing the Riley self dumping underfeed stoker. This stoker is of the inclined undefeed type, differing from other underfeed stokers, in that inclined movable grates are substituted for the ordinary type of dead plates. The booklet is well illustrated, photographs of a number of installations being shown in addition to details of the apparatus.

**AIR COMPRESSORS FOR FOUNDRY USE.**—Bulletin No. 42,800, recently issued by the General Electric Company, Schenectady, N. Y., contains a reprint of an article appearing in the General Electric Review relative to the use of electrically driven air compressors in foundries. The article compares centrifugal compressors with fan blowers and positive type blowers showing the superior features of the centrifugal compressor for this class of service.

**ELECTRIC RAILWAY DATA.**—In Railway Exchange Data No. 10 the Westinghouse Electric & Manufacturing Company, East Pittsburgh, Pa., has brought together considerable data pertaining to the operation of street railways, as well as a number of practical suggestions of value in the operation of electric railway equipment. Among the subjects treated are: Improvement of voltage on interurban lines; Effect of voltage on performance of motors; Cost of stops and trailer operation and Train operation in city and interurban service. The pamphlet contains 32 pages, and is illustrated with a number of curves and drawings

# Railway Age Gazette

MECHANICAL EDITION

INCLUDING THE AMERICAN ENGINEER

PUBLISHED ON THE FIRST THURSDAY OF EVERY MONTH BY THE SIMMONS-BOARDMAN PUBLISHING COMPANY, WOOLWORTH BUILDING, NEW YORK, N. Y.

CHICAGO: Transportation Bldg. CLEVELAND: Citizens' Bldg. LONDON: Queen Anne's Chambers, Westminster.

EDWARD A. SIMMONS, President L. B. SHERMAN, Vice-President HENRY LEE, Secretary

The address of the company is the address of the officers.

Roy V. Wright, Editor

R. E. Thayer, Associate Editor A. C. Loudon, Associate Editor C. B. Peck, Associate Editor

Subscriptions, including the eight daily editions of the Railway Age Gazette published in June in connection with the annual conventions of the Master Car Builders' and American Railway Master Mechanics' Associations, payable in advance and postage free:

United States, Canada and Mexico.....	\$2.00 a year
Foreign Countries (excepting daily editions)....	3.00 a year
Single Copy .....	20 cents

Entered at the Post Office at New York, N. Y., as mail matter of the second class.

WE GUARANTEE that of this issue 4,400 copies were printed; that of these 4,400 copies 3,568 were mailed to regular paid subscribers, 150 were provided for counter and news companies' sales, 234 were mailed to advertisers, exchanges and correspondents, and 448 were provided for samples and office use; that the total copies printed this year to date were 51,450, an average of 4,288 copies a month.

VOLUME 88

DECEMBER, 1914

NUMBER 12

## CONTENTS

### EDITORIALS:

Car Department Competition.....	609
Efficient Cleaning of Locomotives.....	609
Journal Box Packing.....	609
Reducing Water Stops.....	610
The Treatment of Subordinates.....	610
End Construction in Box Cars.....	610
Co-operation and the Stores Department.....	610
Purchasing Material .....	611
High Power Pacific Type Locomotive.....	611
Mechanical Department Appropriations.....	611
New Books .....	612

### COMMUNICATIONS:

Uniform Stenciling of Freight Cars.....	612
The Draft Gear Problem.....	612

### GENERAL:

Most Powerful Pacific Type Locomotive.....	614
Locomotive Front Ends, 1853—1913.....	617
Dividing the Circumference of a Circle.....	620

### CAR DEPARTMENT:

Baltimore & Ohio Milk Refrigerator Car.....	621
Interchange of Cars .....	623
Jersey Central Steel Passenger Cars.....	625
Blue Flag Holder.....	629
The Greatest Weaknesses in Box Cars.....	630
Wooden Cars in Freight Trains.....	631

### SHOP PRACTICE:

Repair Work at Small Engine Houses.....	633
Patching Boilers According to Law.....	634
Firing Up Engines at Engine Houses.....	636
Boiler Shop Methods .....	637
Circular Glass Cutter.....	638
Tool Room Notes.....	638
Forging Machine Dies.....	639
Repairing a Cut Journal.....	640
Painting Locomotives and Steel Cars.....	641
Short Rivet Shear.....	642
Efficiency in a Modern Engine House.....	642
Painting Steel Car Doors.....	643
Tool Clamp for Wheel Lathes.....	644
Reclaiming Car Axles.....	644

### NEW DEVICES:

Circulating System for Locomotive Boilers.....	645
Safety Baggage Rack.....	646
Journal Box Dust Guard.....	646
Emergency Jack.....	647
Square Brake Shaft.....	647
Rivet Buster.....	648
Oxygen Testing Apparatus.....	649
Locomotive Frame Drill.....	649
Shop Illumination by Quartz Lamps.....	650

### NEWS DEPARTMENT:

Notes .....	651
Meetings and Conventions.....	653
Personals .....	654
New Shops .....	654
Supply Trade Notes.....	655
Catalogs .....	656

### Car Department Competition

The first prize of \$50 in the car department competition which closed October 15, 1914, has been awarded to Robert P. Blake, master mechanic of the Northern Pacific at Dilworth, Minn. Mr. Blake's article consists of a practical discussion of the most important weaknesses or defects in box cars, and will be found on another page of this issue. Several of the other contributions have been accepted for publication, and one article in particular is deserving of special mention. It was prepared by Robert N. Miller, instructor in mechanical engineering at the Carnegie Institute of Technology, Pittsburgh, Pa., and discusses at length the defects of modern box cars and the remedies. It will be published in an early issue.

### Efficient Cleaning of Locomotives

An item of economy in locomotive maintenance that should be called more forcibly to the attention of those interested in this work is the cleaning of locomotives with a mixture of oil and water. This process was mentioned at both the General Foremen's and the Master Painters' conventions which were held within the past few months. One road claimed a saving of over \$100 per engine per year by its use. The Delaware, Lackawanna & Western uses a mixture of 150 gal. of hot water to 1 gal. of crude oil. This mixture is sprayed through nozzles, compressed air being used as the driving force. It requires about 18 min. to each engine at an average total cost of 30 cents. Other roads reported a cost per engine as low as 15 cents, stating that when the work is done on a piece work basis the operators will make from \$80 to \$85 per month. It is not necessary to employ expensive labor as the work requires no unusual intelligence. This process not only gives the engine and tender a clean and neat appearance, but makes it possible for the inspectors to detect defects that would otherwise be overlooked.

### Journal Box Packing

Experiments with car journals have shown that the co-efficient of friction with the surfaces efficiently lubricated is from one-sixth to one-tenth that for dry or scantily lubricated surfaces. This means that if one journal on a car is dry or scantily lubricated the power required to move it is approximately that required to move two similar cars efficiently lubricated. Carrying this to extremes, if on one road one journal of each car were absolutely neglected, twice as many locomotives would be required to haul the traffic as would be needed if all journals were maintained in an efficient condition. The same limitations will apply if all the car journals are only maintained to 87.5 per cent of their efficiency. In addition to the power losses there is the loss in time to trains on the road and the damage to equipment on account of hot boxes.

Regardless of the correctness of the above figures the time and money spent in properly maintaining journal boxes is very much worth while. This is becoming more generally recognized by many roads that have established definite intervals at which the journal boxes are to be carefully inspected and overhauled, and until it is the general practice of all roads to do this it cannot be expected that the journal box situation will approach the 100 per cent efficiency mark. Some roads that have followed this practice operate plants to reclaim what is possible from the old packing. One road, as reported at the 1912 convention of the Railway Storekeepers' Association, reclaimed 4,223 lb. of babbitt metal and 171,227 lb. of serviceable waste from 262,548 lb. of old packing at a cost of \$0.37 per 1,000 lb. of the old material. Such procedure would partly compensate for the extra work necessitated by the periodic inspections.

The men entrusted with the maintenance of journal boxes should be carefully instructed as to the proper methods for doing this work. The statements made by car men in papers on this subject before the Missabe Railway Club and the Car Foremen's Association of Chicago show that the point most



overlooked in packing journal boxes is the back of the box; as O. J. Parks stated in a paper before the latter club—"Look out for the back of the box, this is the big bug."

#### Reducing Water Stops

A subject which should be of interest in connection with the use of superheaters on locomotives is the possibility of reducing the number of stops for water. We do not know to what extent the introduction of the superheater has affected the number of stops for this purpose, but it would seem to be an important consideration. In freight service the increased boiler capacity obtained by the use of the superheater is generally pretty well absorbed by an increase in trainload; this is also true in passenger service, but not to the same extent, as in this service the superheater locomotives are more generally employed because of a lack of ability on the part of the saturated steam locomotives to successfully cope with the trains. Of course, if a train is scheduled to stop at a water station the engine crew are more than likely to fill the tank at that point; they are then running less risk of being short of water in case of engine failure or delays further along. But on trains which make long runs without stops there would seem to be possibilities of saving by running the superheater locomotives by water stations at which it was necessary to stop when saturated steam locomotives were used. Just what this saving would amount to it is difficult to say; it would probably not be practicable to eliminate many, if any of the water stations, because of the freight service and the necessity of providing water for smaller locomotives. There is so much variation in conditions that it is impossible to arrive at any very definite conclusion, but it would seem that at least there might be a saving in the expense for pumping.

#### The Treatment of Subordinates

We have at times had occasion to call attention to what has been aptly termed "unintelligent rawhiding," the method followed by some railway officers in dealing with their subordinates, particularly in correspondence. It seems incomprehensible that a superintendent of motive power will treat a man whose intelligence and ability he considers great enough to warrant his appointment as master mechanic of a division, in a manner which should arouse criticism if assumed toward a ten-year-old child, but any railroad man of however little experience knows that this is often the case. A short time ago, in reply to an explanation on his part, of an engine delay for which he was not responsible, a foreman received from his master mechanic a telegram which began "Cannot believe your explanation." The master mechanic would not have made this statement verbally outside the privacy of his own office, yet he did not hesitate to include it in a telegram which besides being read by the sending and receiving operators, was given careful attention by the boy who carried it from the telegraph office to the engine house, by two clerks in the engine house office and by the call boy who finally carried it to the foreman, who was out of the office at the time. Its contents were, of course, known throughout the engine house in a very short time.

Every one is familiar with the argument advanced by the authors of such correspondence that it is necessary to sometimes "go after a man hard" in order to keep before him the realization of his responsibilities. This line of reasoning, if it can be dignified as such, has long since gone out of date and its employment at the present stage of railroad work does not indicate great intelligence on the part of the man advancing it. The wonder is that very often the officer who makes use of this argument is the first to admonish his subordinates to use every care in their treatment of the men under them. Why a foreman or a master mechanic is not entitled to just as courteous treatment as a machinist or boilermaker is hardly apparent,

and the more such officers receive this "rawhiding" the more likely they are to cause trouble and dissension in the ranks by taking it out on the men under them. There is not enough attention given to the matter of courtesy in railroad correspondence; the higher officers are largely to blame for this condition and can do much to eliminate it.

#### End Construction in Box Cars

Attention has repeatedly been called to the weakness of the end construction of a great many of the box cars now in service. In some of the more modern cars the weakness is not so much in the members of the end frames themselves as in their connection to the other members of the car framing. An example of such weakness may be seen in the car with end posts consisting of heavy I-beams or Z-bars connected to end sills and end plates by one or two rivets or some similar attachment, the strength of which is a mere fraction of the strength of the post itself. In designing steel passenger train cars a great deal of attention has of necessity been given to the end construction in order to avoid telescoping in case of collision. Heavy end posts, both in the body end and the vestibule, are employed and special pains are taken to connect them to the underframe and through the end plate to the side frames; these points are deserving of careful consideration in the designing of box cars. A box car with ends that are put out of service with the first heavy shock or shifting of the load, is not of much use in the moving of traffic under present day conditions and end construction in this type of equipment can be greatly improved by more care in connecting the end and corner posts to the end sill, and the end sill to the underframe, and also, by providing a substantial end plate with corresponding connections between it and the upper ends of the posts. Careful consideration should also be given to connecting and bracing the end plates to the side framing of the car. Heavy wooden sheathing or a steel plate extending the width of the car and covering the greater part of the end is of material assistance in strengthening the end structure, but particular attention should be given to its connection to all of the end posts in order that it may help in distributing shocks over the entire end frame, mitigating as much as possible the strains to be borne by individual posts.

#### Co-operation and the Stores Department

In considering the desirability of co-operation between departments in railroad work, it is perhaps natural that the operating and mechanical departments should come first to mind. The business of a railroad is to provide transportation, and in this the motive power, car and operating departments are most directly concerned. However, co-operation or lack of it on the part of the stores department may have a very direct bearing on transportation costs. Severe censure is poured out on the head of the mechanical department man who fails to realize that his first attention always should be to provide the operating department with locomotives. He becomes so absorbed in his own department that he forgets that his duty is not to repair locomotives, but to repair locomotives so that they may be used in moving trains; but this applies also to the storekeeper. There is a tendency on the part of some members of the stores department organization toward a narrow view of their part in the transportation problem.

The stores department man who keeps mechanics standing around awaiting his pleasure is well known; he either does not realize, or does not care, that while he is apparently putting a machinist or a boilermaker in what he considers his proper place by making him await the pleasure of the stores department, he may be delaying material that will in turn delay a locomotive and hold up several trains. Then there is the storekeeper who insists on following the most roundabout way in getting a casting or other heavy material for which a locomotive is being held out of service. It is not intended to be-

little his efforts to have a correct record of all material which passes through his hands; this is a necessity, but it can still be accomplished and time very often saved to the mechanical and operating departments by a little extra effort on his part or that of his subordinates. Stores department men are often prone to think of themselves as detached from the hustle and bustle of moving trains, but a little careful consideration will bring them to realize that they have a very direct part in it and that their co-operation with other departments is not only desirable but essential.

#### Purchasing Material

There are many instances in which the specification of material is left entirely to the purchasing agent and the selection made on the basis of first cost, when from the standpoint of economy it might better be selected according to the recommendations of the officers in the department using the material. This statement undoubtedly applies in a restricted sense to the larger railway systems having test departments charged with the preparation of specifications for certain materials and the selection of others from the results of service trials. There are many roads, however, too small to maintain departments of this nature, on which the selection of materials is left very largely to the discretion of the purchasing agent. In the absence of data as to the comparative serviceability of different qualities, the material having the lowest first cost is very frequently selected, even though the aggregate expenditure in the course of a year is much greater than would have been the case if a better but more expensive quality had been secured. There are cases where such practices may be followed by the purchasing department even against the protest of the department using the material, but the fault does not lie wholly with the purchasing department. It is largely due to the lack of adequate records showing the actual service performance of various classes of material and devices, especially in the motive power department. While officers of this department may have well defined opinions as to the best quality of material for a certain use based upon general observations, such opinions do not carry the weight that would be accredited to them were they backed by adequate service records. The clerical work necessary to keep these records undoubtedly involves some expense and requires careful consideration to insure that time is not wasted in gathering useless information. But, if properly kept, the returns from them will be far greater than the expenditure. The question of keeping such records is one which should be given careful study by motive power department officers.

#### High Power Pacific Type Locomotive

According to our records the Pacific type locomotive for the Chesapeake & Ohio, described elsewhere in this issue, is the most powerful, as well as the heaviest, locomotive of this type yet built. The total weight of this engine is 312,600 lb., and it will develop a maximum tractive effort of 46,600 lb. A Pacific type locomotive recently built by the Baldwin Locomotive Works for the Carolina, Clinchfield & Ohio, and described in the *Railway Age Gazette* of November 27, 1914, page 1005, has practically the same maximum tractive effort, but the steam pressure is 200 lb. per sq. in., against 185 lb. for the Chesapeake & Ohio locomotive, the cylinders being 25 in. by 30 in. against 27 in. by 28 in.; the driving wheels are 69 in. in diameter in both cases. As will be seen by the table accompanying the description of the Chesapeake & Ohio locomotive there is considerable difference between these two engines in point of sustained capacity, the boiler of the Chesapeake & Ohio engine being considerably larger, resulting in a total heating surface of 4,478 sq. ft. against 3,982 sq. ft. in the Clinchfield engine. A comparison of the Chesapeake & Ohio locomotive with the Pennsylvania Railroad's Pacific type, class K-4-s is also of interest. The tractive effort of the Pennsylvania locomotive is 41,800 lb., and

the total weight 312,000 lb., while the weight on drivers is 200,000 against 191,400 lb. in the case of the Chesapeake & Ohio. Again the boiler is considerably larger, the new locomotive having tubes 18 in. longer than the Pennsylvania locomotive, while the diameter at the front end is 5 in. greater than the Pennsylvania boiler. The total heating surface of the Pennsylvania and Clinchfield locomotives is almost the same, but taking the superheater into consideration the total equivalent heating surface is 5,965 sq. ft. for the Chesapeake & Ohio locomotive, 5,414 sq. ft. for the Clinchfield and 5,756 sq. ft. for the Pennsylvania K-4-s. The boiler pressure of the Pennsylvania locomotive is 205 lb. In the Chesapeake & Ohio locomotive the ratio of total weight to maximum tractive effort is 6.72; in the case of the Carolina, Clinchfield & Ohio locomotive this figure is 6.09; in the Pennsylvania it is 7.28; in the American Locomotive Company's experimental locomotive No. 50,000 it is 6.68, and in the Chesapeake & Ohio Mountain type locomotive, built in 1911, it is 5.69.

#### Mechanical Department Appropriations

There is room for considerable improvement in the assignment of appropriations in the mechanical department. We have in mind a case which was especially bad and while it is improbable that such poor reasoning is followed in very many instances it provides an example of how illogically this problem is sometimes attacked. A new terminal was opened and the foreman informed that his appropriation for the month would be \$1,000. He made an estimate of the probable expenditures for the month and found that even with the most rigid economy they would not be less than \$1,800; he wrote to the master mechanic protesting against the low appropriation and enclosing an analysis of the necessary payroll expenses. This letter was ignored. By laying off a number of men, avoiding all overtime and slighting considerable important repair work he managed to get through the month with a payroll total of \$1,780. It is not necessary to dwell on the correspondence that followed beyond the fact that not one of the foreman's arguments was answered by his superior; but the next month's appropriation was again \$1,000. This was continued for several months, the expenditures running from \$500 to \$750 over the amount allotted. The same discussion by correspondence took place each month, varied only by a veiled intimation that it might be necessary to change foremen at that particular terminal. Suddenly, without a word of explanation being given, the appropriation was increased to \$1,500 and the month following to \$2,000; the reason for this increase was that pressure had been brought to bear on the mechanical department because of the large number of engine failures chargeable to this terminal, but this fact did not become known until later. As a matter of fact, the power was in such condition that it was then impossible to put it in shape without exceeding even this last appropriation, and this was the case for three months.

There are several points worth considering in the foregoing, but the most important would seem to be the relation between engine house appropriations and engine failures. The master mechanic in this case did not look beyond actual payroll expenditures. Like a great many others he told his foremen "You must give more attention to *this*; more time will have to be given to keeping up *that* particular line of repairs; we are having too many engine failures." But more time spent on terminal repairs means more men, and more men means more money; the mere issuing of instructions will not carry out the work of repairs. The difficulty is in getting mechanical department officers to see beyond expenditures which come directly under their own attention; it is difficult to make an accurate estimate of the cost of an engine failure, but it is safe to say that it is almost invariably greater than the cost of making the repairs that would have prevented it. Cutting appropriations to an unreasonable extent in order to reduce maintenance expenses on locomotives is and always has been ex-



pensive economy. Engine failures cause expenses and annoyance, the results of which may be in evidence for months after the occurrence and the easiest way to prevent them is by thorough repairs at terminals. This means an engine house appropriation large enough adequately to cover the necessary expense. After all, the matter of appropriation resolves itself mainly into first consideration being given by officers and employees of all departments, not to their own immediate departmental difficulties, but to the broader problem of the economical movement of trains.

### NEW BOOKS

*Thermal Properties of Steam.* By G. A. Goodenough, Professor of Thermodynamics, University of Illinois. 69 pages, 6 in. by 9 in. Illustrated with diagrams. Bound in paper. Published by the Engineering Experiment Station, University of Illinois, Urbana, Ill. Price 35 cents.

This bulletin presents a critical discussion of the experimental investigations of the various thermal properties of steam, an outline of the thermodynamic relations that must be satisfied, and finally the development of a general theory of superheated and saturated steam. As a basis for such a theory the Munich experiments on specific volumes and specific heats are taken and properly correlated through the Clausius relation.

*Foremen and Accident Prevention.* 80 pages, 4 in. by 6 in. Bound in paper. Published by the Travelers Insurance Company, Hartford, Conn.

This book is intended to be studied in connection with a companion booklet previously issued by the Travelers Insurance Company and entitled *The Employee and Accident Prevention*. The earlier one takes up the subject from the standpoint of the worker, who has but little power to modify the conditions under which the work is done, while the present one approaches it from the point of view of the executive and administrative departments and gives suggestions with regard to the management of the workers and the improvement of the plant with a view to increased safety.

*Railway Rolling Stock Appliances and Equipment.* Compiled and arranged by Parker Cook, Victor Building, Washington, D. C. 16 pages, 3¾ in. by 6 in. Bound in paper. Copies free.

Patent attorneys receive numerous inquiries from clients as to the number of patents in the different sub-classes, and so far as is known there has been up to the present no publication that gives this information. This book gives the number of patents in each class and sub-class and was compiled after considerable research work. It is so arranged that an inventor or any one desiring such information can at once determine how many patents there are in any sub-class. It should prove of particular value to inventors, as they can determine at once from it how many patents there are in the various sub-classes.

*The Science and Practice of Management.* By A. Hamilton Church. 535 pages, 4¾ in. by 7¼ in. Illustrated with charts. Bound in cloth. Published by the Engineering Magazine Company, 140 Nassau street, New York. Price \$2.

This book constitutes the latest addition to the Works Management Library of the Engineering Magazine. The author's treatment of the subject seems to be scientific, not in the sense that he sets forth any system of so-called scientific management, but that he attempts in a scientific way to get at the fundamental elements and principles, so that existing forms of management can be scientifically analyzed and classified. It has been endeavored to ascertain the fundamental facts of production, not from the viewpoint of cost but from the viewpoint of management. Instead of trying to throw light on the nature of expense the author has endeavored to throw light on the nature of organization. The book is an attempt to formulate such fundamental facts and regulative principles as may be later developed into a true science of management, and is not one from which the "rule of thumb" practitioner can obtain a ready-made system.

## COMMUNICATIONS

### UNIFORM STENCILING OF FREIGHT CARS

WHISTLER, Ala.

TO THE EDITOR:

The uniform stenciling of freight cars has been discussed by the Master Car Painters' Association for several years for the purpose of simplifying this feature of foreign car repairs and to expedite their movement through the various repair yards, but thus far little has been accomplished. The matter of standardizing all lettering relating to the dimensions and equipments of freight cars of all classes is perfectly feasible. At present the size of the letters used on the cars of the various roads varies from ¾ in. to 3 in. in height, and there is no reason why these should not be standardized in order to facilitate the work of relettering whenever repairs make it necessary. This part of the cost of stencil making for foreign cars, which is considerable in many instances, could be entirely obviated by standardizing. A feasible plan for effecting this change is to have the Master Car Painters' Association submit a suitable style and size of letter to the Master Car Builders' Association for approval and adoption, then a blue print copy showing style and full size of letters should be made, and a copy furnished each company with a request that it be put into effect on all new and repainted equipment.

J. H. PITARD.

### THE DRAFT GEAR PROBLEM

CHICAGO.

TO THE EDITOR:

I noticed a communication in your September issue, page 453, entitled "Spring versus Friction Draft Gears." Knowing, as I do full well, the policy of your journal to publish facts, and not near facts or misrepresentation of facts, I am prompted to write you as I do on this subject.

I have noted that the writer of the communication says about the "home dog" and the "tramp dog." I don't just see what either dog has to do with the freight car or the draft gear, except that most cars "go to the dogs" for want of efficient gears. The writer refers to the "essential points" of a draft gear, one of which is the "initial resistance to permit an easy starting of the train." When all of our cars are equipped with high capacity friction draft gears, and all the cars are new, it will be time enough to talk about "initial resistance." At the present time, and in the present condition of freight car equipment, we have all the natural slack that we need, due to wear and tear, to permit the starting of any train.

I am willing to admit that "there is a vast difference between a mechanical engineer and a railway switchman," but I am unwilling to admit that the "former takes one single gear into the laboratory and takes the time necessary to very carefully and gently compress it." The days of the static tests have gone by. Railroad men are not testing out their draft gears in this manner. Such a test has been discarded, and in its place has come the drop hammer test. Static tests of draft gear have been so far and long superseded by other tests that it is almost a joke to refer to them at the present time. We must admit that the railway switchman is not always a careful individual, and that cars are moved and run around and sent into each other at a terrific speed, but your correspondent forgets that these shocks are to be taken care of not by a single draft gear, but by many, and that when a switchman "throws a cut of loaded cars down against other cars standing still, with the usual high sign (put them into clear), which means at speeds of from five to ten miles an hour, and sometimes more," the resulting shock is not put upon one draft gear, but upon many. A great many men, in figuring the amount of energy developed, immediately come to the conclusion that one single draft gear cannot stand it, forgetting that

one gear does not have to stand it, but simply that one of many gears has to stand its proportion of the shock. For example, if four cars are sent against four other cars at a certain rate of speed, when the two lots of cars come together the shock of meeting is not taken up by one draft gear, nor even by two draft gears, viz.: the two back of each of the two couplers that come together. In the eight cars taken as an example, there are of course sixteen draft gears, and all but two of these draft gears come into play, leaving fourteen draft gears to take up the shock.

After proving that no one draft gear manufactured can withstand some of the very heavy shocks (they don't have to alone), the writer of the communication states: "Thus we are forced to admit that we are unable to entirely absorb or to destroy the shocks with any kind of draft gear. The underframe must do it or the car is out of commission." No one is going to question the very great importance of a properly designed and constructed underframe, nor the fact that it must do its part in taking up the shocks or blows. We would argue always in favor of a stronger car from wheels to roof because of the punishment which cars are bound to receive in service. But when the cost of a car is so many times that of a draft gear, why not attempt to minimize as much as possible and destroy, if you can, the effects of shocks? If the underframe is to take care of the shock, and the capacity of our draft gear is to be the minimum rather than the maximum, what are we going to do with the lading? Our lading is a pretty important item. As a matter of fact that is what the freight car is built for, and in a discussion of how it should be built and how it should be protected the lading should always be given a consideration. Cars could be built to stand up in service without draft gears. We have not by any means built the strongest freight cars that it is possible to construct. Cars, of course, can take up, either in the underframe or in the car body, tremendous shocks, but unless we are to have a constantly increasing expense in the way of damaged lading we would have to pad the insides of cars or swing the lading in hammocks.

The natural thing to do when we are facing shocks in train service is to have them minimized or eliminated by the operating department, or else have them minimized or eliminated by the mechanical department. It is folly to expect to take care of them in the cars, not only on account of the car itself, but on account of the lading. The reasonable thing to do is to have the operating department insist on the greatest care in the handling of cars so as to prevent shocks, and for the mechanical department to insist upon the best appliance upon the end of a car to minimize or else destroy entirely the effects of these shocks before they can reach the car and the lading. The solution of the difficulty is in a shock destroying and not in a shock distributing draft gear.

Only with draft gear of high capacity and no recoil are we going to eliminate the break-in-two in train service. On this whole subject, we must deal with maximums and not with averages. If we could eliminate the maximum shock—to be sure of an average shock—we could build our cars to withstand them and eliminate the draft gear, so far as its protection from the effects of shock to the car is concerned, but not to the lading. However, the very fact that we are dealing with the unknown, the unusual, and the unexpected, in the blows which the car receives in service, is what makes doubly necessary the draft gear. We have to contend with maximum blows of a million pounds. We have locomotives with a tractive effort of 125,000 lb., and we have trainloads of 7,500 tons. With such equipment and rolling stock we are bound to develop energy to a large amount, and for the protection of the car, we must have something that will kill shock—not receive it, sending it back again and again in the shape of recoil.

The argument is made, in the article you published, in favor of spring gears of high capacity, the writer saying that "the greatest argument against the spring gears is a supposed re-

coil, but recoil we must have, or we have no draft gear." On this point I would rather quote from a man of recognized authority than simply to make a statement, and I quote from no less authority than F. B. Farmer, who, in a paper on Break-in-Twos presented at a meeting of the Air Brake Association said: "To get a high capacity by the use of more and stronger springs is now generally recognized as 'out of the frying pan into the fire,' because the greater stored up power possible with such springs adds but that much more to the forces acting to change slack suddenly." The danger of recoil in draft gear from the standpoint of trains parting is too well known by railway men to neglect it in the establishing of requirements for a draft gear. To make a draft gear successful, it must be a non-recoil shock destroyer. A spring draft gear, simply because it is a spring draft gear, must have recoil, and the higher the capacity of the springs, the higher the recoil. Mr. Farmer has probably done more road work than any other man in the United States, and when he condemns recoil, I for one must agree with him.

Reference is made to the "laboratory tests given by Mr. Newell, a nine thousand pound weight falling five and one-half inches, closing the most powerful draft spring solid, shows discrimination between spring and friction gears, as no one would use a single spring gear at this date. . . ." I take it that Mr. Newell made his comparisons between a spring draft gear and a friction draft gear, and not between a single spring and a friction gear. The most powerful spring draft gear would consist of two 8 in. by 8 in. springs with a capacity of 30,000 lb. each, which makes some difference in the comparison.

Then another statement is made to the effect that "when the springs in the ends of the cars exceed the carrying capacity of the cars, the best results are obtained," but would these "best results" be obtained at a car movement of one mile per hour, or at ten miles per hour, or between the two? Ten miles per hour is a pretty rapid movement, but I mention ten as being the maximum given by the writer of this paper.

One more point in this letter published by you; the writer says, "the resistance should be increased and the drawbar travel should be reduced." There are just two ways of increasing the capacity of a draft gear. One is to increase its size, and the other is to increase the amount of time given it to do its work. These two principles of draft gear construction are so axiomatic that it is hardly necessary to discuss them. Now, if we are to increase the amount of time to be given to the draft gear to do its work, we must increase the travel, and a draft gear having a travel of 4 in. certainly will do more work than a draft gear having a travel of 1¼ in. It has more time in which to work. It seems to me that when the writer of the communication to your column says "the resistance should be increased and the drawbar travel should be reduced," he is contradicting himself.

BRUCE V. CRANDALL.

**DRAFT VALUE.**—Each quality of fuel used requires a special draft value. For run-of-mine bituminous coals an average of 0.01 in. of water is allowed for each pound of coal fired per hour. Thus two 300-h.p. boilers having a total of 106 sq. ft. of grate area and burning 20 lb. of fuel per sq. ft. per hour would require a draft of  $(20 \times 0.01 \text{ in.}) = 0.2 \text{ in.}$  The draft actually used will generally be from two to five times that really required.—*Power.*

**STRENGTH OF DRILLED STEEL.**—Tests made in France and reported in *Le Genie Civil* indicate that when holes are drilled and then reamed in soft steel, the metal between the holes increases on an average of nine per cent in its ultimate strength and twelve per cent in its elastic limit. This condition is explained as being due to the fact that the metal is compressed and thus offers a higher tensile resistance to rupture. Hence, if several holes are drilled, so as not to injure the material as in punching, the average tensile strength of the section across the holes per unit area of metal will be higher than before the holes were drilled.—*Machinery.*



# MOST POWERFUL PACIFIC TYPE LOCOMOTIVE

Maximum Tractive Effort of 46,600 lb. and a Boiler Which Provides High Sustained Capacity

Six exceptionally large and powerful Pacific type locomotives have recently been delivered to the Chesapeake & Ohio by the American Locomotive Company. They have a maximum tractive effort of 46,600 lb., and are believed to be the most powerful Pacific type locomotives ever built, the nearest in point of tractive effort being a locomotive of the same type, recently built by the Baldwin Locomotive Works for the Carolina, Clinchfield & Ohio. This engine has a maximum tractive effort of 46,000 lb. The Chesapeake & Ohio engines are not only exceptional in having such a large tractive effort, but also have a boiler large enough to sustain it.

These locomotives have been put in service between Charlottesville, Va., and Hinton, W. Va., a distance of 175 miles. This

tioned train is 25½ miles per hour, and for the second 35 miles per hour for this 13 miles. The schedule over the remaining part of the division permits but little time to be made up. These new engines, while as yet in service but a short time, are satisfactorily handling these trains.

It is particularly interesting to note the extent to which this railway has gone in introducing large and powerful locomotives. The Mallet, Mikado and Mountain types now in use on this road are among the most powerful of their types and have made remarkable reductions in operating costs by increasing the train-loads. The achievements of these locomotives have justified the officers in designing these large Pacifics. No innovations were attempted, but the different factors were combined to give as

	Tractive effort, lb.	Total weight, lb.	Weight on drivers, lb.	Cylinders	Diameter of drivers	Boiler diameter	Grate area, sq. ft.
C. & O. 4-6-2.....	46,600	312,600	191,400	27 in. by 28 in.	69 in.	83 11/16 in.	80.33
C. C. & O. 4-6-2.....	46,000	280,300	176,900	25 in. by 30 in.	69 in.	78 in.	53.8
Pennsylvania 4-6-2 (K-4-s).....	41,800	305,000	200,000	27 in. by 28 in.	80 in.	78½ in.	70
50,000 .....	40,800	269,000	172,500	27 in. by 28 in.	79 in.	76¾ in.	59.75
C. & O. 4-8-2.....	58,000	330,000	239,000	29 in. by 28 in.	62 in.	83¾ in.	66.7

	Number of flues	Number of tubes	Length of tubes and flues,	Working pressure	Heating surface, sq. ft.	Equivalent heating surface, sq. ft.
C. & O. 4-6-2.....	43—5½ in.	244—2¼ in.	20 ft. 6 in.	185 lb.	4,478.8	5,965.3
C. C. & O. 4-6-2.....	38—5½ in.	211—2¼ in.	21 ft.	200 lb.	3,982	5,414
Pennsylvania 4-6-2 (K-4-s).....	40—5½ in.	237—2¼ in.	19 ft.	205 lb.	4,035.4	5,756.3
50,000 .....	36—5½ in.	207—2¼ in.	22 ft.	185 lb.	4,048	5,394
C. & O. 4-8-2.....	40—5½ in.	243—2¼ in.	19 ft.	180 lb.	4,132	5,399

part of the line crosses three mountain summits: the Blue Ridge, North Mountain and the Alleghanies. To economically handle the through passenger service is a difficult problem. The mountain resorts, among which are the Virginian Hot Springs and the White Sulphur Springs of West Virginia, demand the very best of service and equipment. Trains of ten all-steel cars, weighing 674 tons, are a regular daily problem. This has required frequent resorting to double heading.

The requirements that must be met in order to make the schedule time on the Clifton Forge division are extremely diffi-

powerful a machine as possible within the clearances. The accompanying table gives a comparison between the Chesapeake & Ohio Pacific type and a number of other large locomotives.

The exceptional capacity of the boiler warrants special attention. It is of the extended wagon top type, and at the first course the barrel is 83 11/16 in. in diameter outside, while the outer diameter of the largest course is 90 in. The barrel is fitted with 244 tubes, 2¼ in. in diameter, and 43 flues, 5¼ in. in diameter and 20 ft. 6 in. long. The firebox is 120½ in. long and 56¼ in. wide, having a total depth of 82¼ in. The depth from

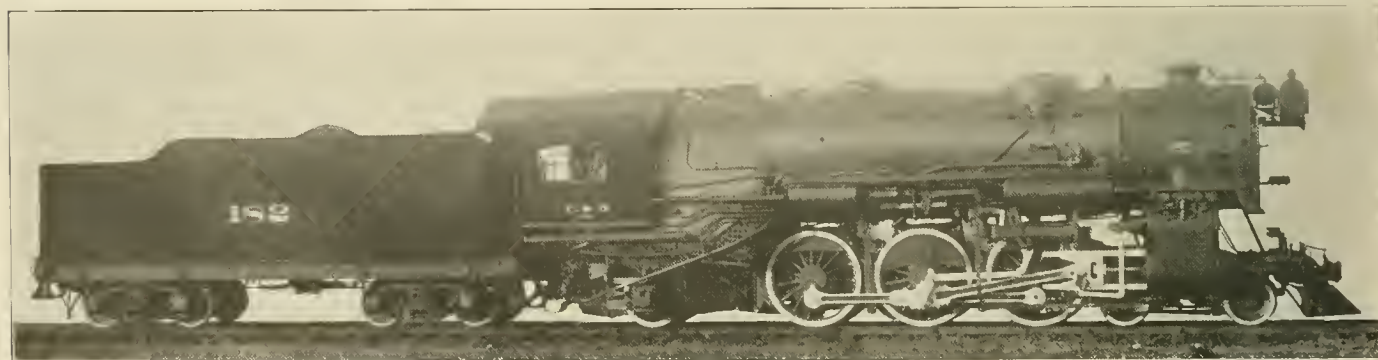

Chesapeake & Ohio Pacific Type Locomotive for Heavy Passenger Service in Mountainous Country

cult. Westbound from Mechums River to the summit of the Blue Ridge is a continuous uncompensated grade of 75 ft. to the mile, with curves of 10 deg., and extending a distance of 14 miles. One train of ten steel cars, weighing 674 tons, is scheduled at 22½ miles per hour on this grade, while another train of eight steel cars, weighing 551 tons, is scheduled at 29 miles per hour. From Staunton to the summit of North Mountain, a distance of 13 miles, the conditions are still more difficult. The first 6½ miles contains 4½ miles of up-grade, varying from 75 to 80 ft. to the mile, and the last 6½ miles is a continuous grade of 80 ft. to the mile. The scheduled speed for the first men-

the center of the lowest tube to the top of the grate is 25½ in.

According to the American Locomotive Company's standard system of boiler proportioning, a cylinder 27 in. in diameter using superheated steam having a pressure of 185 lb. will develop 2,427 cylinder horsepower. One cylinder horsepower requires an evaporation of 20.8 lb. of steam per hour. To develop full cylinder horsepower a total evaporation of 2,427 x 20.8, or 50,500 lb. of steam per hour is required. Boiler tubes 2¼ in. in diameter, 20 ft. 6 in. long and spaced ¾ in. give an evaporation of 8.69 lb. of steam per square foot of heating surface per hour. Boiler flues 5½ in. in diameter, 20 ft. 6 in. long,





spaced  $\frac{3}{4}$  in. give an evaporation of 9.86 lb. of steam per square foot of heating surface per hour. Firebox and arch tubes give an evaporation of 55 lb. of steam per square foot of heating surface per hour. The total tube heating surface is 2,933 sq. ft., total flue heating surface is 1,263 sq. ft., total firebox heating surface is 255.4 sq. ft., and total arch tube heating surface is 27.4 sq. ft. This boiler therefore will give a total evaporation as follows:

Tubes	2,933	×	8.69	=	25,500 lb.
Flues	1,263	×	9.86	=	12,450 lb.
Firebox	255.4				
Arch tubes	27.4				
	282.8	×	55	=	15,550 lb.
Total					53,500 lb.

The total boiler evaporation, 53,500 lb. divided by the total evaporation required, 50,500, gives a 106 per cent boiler. This indicates that this engine can be worked indefinitely at its full capacity. To insure a constant supply of fuel to this boiler burning bituminous coal and having a grate area of 80.4 sq. ft., a mechanical stoker had to be applied.

The large boiler and wide firebox and the application of the stoker made the arrangement of the cab a difficult matter, and this was facilitated considerably by the use of non-lifting inspirators, Ragonnet reverse gear and the placing of the steam turret outside of and in front of the cab. Clearance restrictions made it

Ratios	
Weight on drivers ÷ tractive effort	4.12
Total weight ÷ tractive effort	6.72
Tractive effort × diam. drivers ÷ equivalent heating surface	538
Evaporative heating surface* ÷ grate area	55.80
Equivalent heating surface* ÷ grate area	74.30
Firebox heating surface ÷ equivalent heating surface*	4.74
Weight on drivers ÷ equivalent heating surface*	32.25
Total weight ÷ equivalent heating surface*	52.30
Volume of both cylinders, cu. ft.	18.55
Equivalent heating surface* ÷ volume of cylinders	322.00
Grate area ÷ volume of cylinders	4.33

Cylinders	
Kind	Simple
Diameter and stroke	27 in. by 28 in.

Valves	
Kind	Piston
Greatest travel	.6 in.
Outside lap	.1 in.
Inside clearance	$\frac{1}{8}$ in.
Lead	$\frac{3}{16}$ in.

Wheels	
Driving, diameter over tires	.69 in.
Driving, thickness of tire	$\frac{3}{32}$ in.
Driving journals, main, diameter and length	$1\frac{1}{2}$ in. by 23 in.
Driving journals, others, diameter and length	$1\frac{1}{2}$ in. by 14 in.
Engine truck wheels, diameter	.33 in.
Engine truck journals, diameter and length	.7 in. by 12 in.
Trailing truck wheels, diameter	.45 in.
Trailing truck journals, diameter and length	$\frac{9}{16}$ in. by 16 in.

Boiler	
Style	Wagon top
Working pressure	185 lb.
Outside diameter of first ring	$83\frac{11}{16}$ in.
Firebox, length and width	$120\frac{1}{8}$ in. by $96\frac{1}{4}$ in.

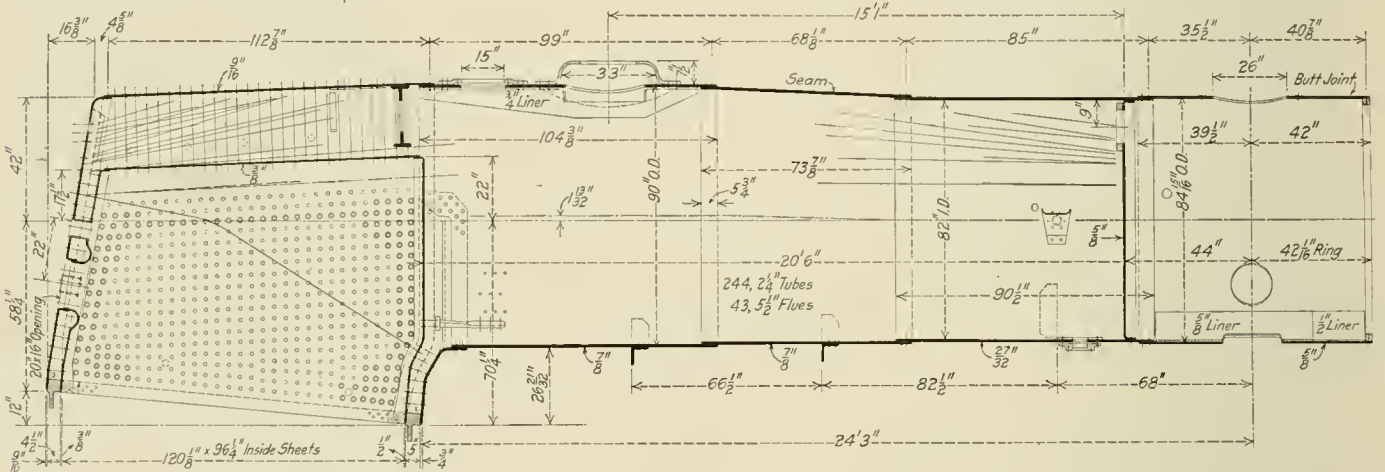

Boiler for the Chesapeake & Ohio Pacific Type Locomotive

necessary to place the bell off the center of the boiler and the headlight dynamo in front of the smoke box.

The frames are 6 in. wide and braced by box castings. The piston rod extension is the American self-centering type. Walschaert valve gear is used with the valve stem guide integral with the steam chest cover; the piston valves are 16 in. in diameter.

The special equipment includes the Schmidt superheater, Cole outside journal trailing truck, radial buffing device, American arch, Franklin pneumatic grate shaker. Cole long main driving box, Trojan packing, Vanadium steel frames and rods, Mellin by-pass valve, Hancock 5,500 gallon capacity non-lifting inspirators, Watters sanders, Nathan lubricators, Westinghouse-American driver brakes and Westinghouse-Farlow draft gear. The following are the principal dimensions and ratios:

General Data

Gage	4 ft. 8 1/2 in.
Service	Passenger
Fuel	Soft coal
Tractive effort	46,600 lb.
Weight in working order	312,605 lb.
Weight on drivers	191,455 lb.
Weight on leading truck	56,675 lb.
Weight on trailing truck	64,475 lb.
Weight of engine and tender in working order	497,100 lb.
Wheel base, driving	13 ft. 0 in.
Wheel base, total	34 ft. 9 in.
Wheel base, engine and tender	71 ft. 11 1/2 in.
Length over all	82 ft. 6 1/2 in.

Firebox plates, thickness	$\frac{3}{8}$ in. and $\frac{1}{2}$ in.
Firebox water space	$4\frac{1}{2}$ in. back and sides; 5 in. front
Tubes, number and outside diameter	244—2 1/2 in.
Tubes, material and thickness	Seamless steel, 0.125 in.
Flues, number and diameter	43—5 1/2 in.
Flues, material and thickness	Seamless steel, 0.15 in.
Tubes and flues, length	20 ft. 6 in.
Heating surface, flues	1,263 sq. ft.
Heating surface, tubes	2,933 sq. ft.
Heating surface, firebox	255.4 sq. ft.
Heating surface, arch tube	27.4 sq. ft.
Heating surface, total	4,478.8 sq. ft.
Superheater heating surface	991.0 sq. ft.
Equivalent heating surface	5,965.3 sq. ft.
Grate area	80.33 sq. ft.
Smoke stack, diameter	20 in.
Smoke stack, height above rail	14 ft. 9 1/2 in.

Tender	
Frame	13 in. steel channels
Wheels, diameter and material	36 in. forged steel
Journals, diameter and length	.6 in. by 11 in.
Water capacity	9,500 gal.
Coal capacity	154 tons

\*Equivalent heating surface = evaporative heating surface + 1.5 times superheater heating surface.

DRAFTING DICTIONARY NEEDED.—The language of the engineer can be called the only existing language with any extended use which has no authority to which reference may be made in regard to symbols and conventions. Each drafting office has its own colloquialisms, its own dialect. The crying need of the moment may be said to be the compilation of a dictionary of drafting.—American Machinist.

# LOCOMOTIVE FRONT ENDS, 1853-1913

Sixty Years' Development on the Baltimore & Ohio;  
Changes Made from the Time of Wood Burners

BY C. T. ROMMEL

Owing to the many different kinds of coal burned, the drafting of locomotives has always been a very important question on the Baltimore & Ohio. In the eastern territory the coal used is soft and gas from a number of different mines in the Pennsylvania and West Virginia districts, and in the western territory the coal used is generally a gas coal from the Ohio district and a semi-bituminous coal from the Illinois and Indiana districts. It has been the aim to draft locomotives so that when they are transferred from one territory to another the front end arrangement will produce a free steaming engine

that point; the fuel used generally was wood, on account of which the deflector plate was not as necessary as if coal were used.

Fig. 2 shows the arrangement used in 1873 on a Consolidation engine with the following dimensions:

Cylinders .....	20 in. by 24 in.
Boiler pressure.....	130 lb.
Grate area .....	24.97 sq. ft.
Firebox heating surface.....	1,239.94 sq. ft.
Total heating surface.....	1,373.47 sq. ft.
Tractive effort .....	21,216 lb.
Total weight of locomotive.....	104,100 lb.

With this arrangement the inside steam pipes were used in connection with the half saddle cylinder and the smokebox is circular in form. The netting was located in the top of the stack and no deflector plate was used, although it would appear that the necessity of such a plate was being realized by the arrangement used around the exhaust base, which is rather peculiar.

Fig. 3 shows the arrangement used in 1883 on a ten-wheel type locomotive. These engines had the following dimensions:

Cylinders .....	19 in. by 24 in.
Boiler pressure.....	150 lb.
Grate area .....	23.61 sq. ft.
Firebox heating surface.....	134.22 sq. ft.
Tube heating surface.....	1,326.62 sq. ft.
Total heating surface.....	1,460.84 sq. ft.
Tractive effort .....	19,724 lb.
Total weight of locomotive.....	113,200 lb.

This arrangement, it will be seen, shows the adoption of the deflector plate and the netting in the smokebox instead of inside the stack. The exhaust base and nozzle are exceptionally high

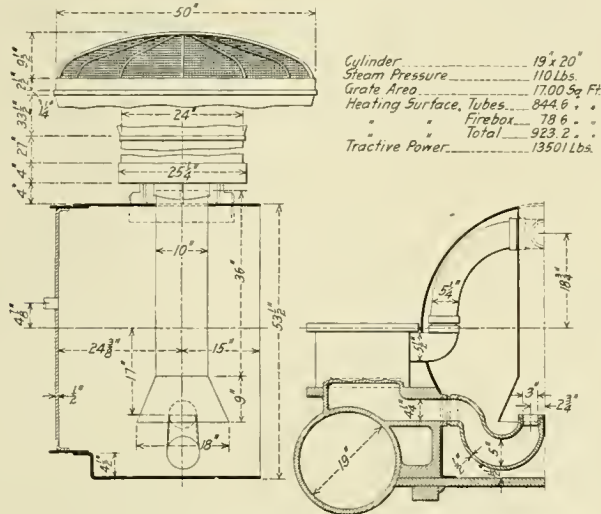

Fig. 1—Front End Arrangement Applied In 1853

with minimum coal consumption and require no change, except perhaps a reduction in the size of the exhaust nozzle.

In view of this, it is interesting to study the different arrangements of front ends that have been used on this road from 1853 to the present.

Fig. 1 shows about the first front end arrangement applied, in 1853. Prior to this time the locomotives in use were of the Grasshopper type, which did not have a smokebox, and therefore did not require any front end arrangement. The arrangement shown in Fig. 1 was used in a Camel 10-wheel engine with the following dimensions:

Cylinders .....	19 in. by 20 in.
Boiler pressure.....	110 lb.
Firebox.....	17 sq. ft.
Grate area.....	17 sq. ft.
Firebox heating surface.....	78.6 sq. ft.
Tube heating surface.....	844.6 sq. ft.
Total heating surface.....	922.2 sq. ft.
Tractive effort .....	13,501 lb.
Total weight of locomotive.....	77,000 lb.

At this time, it will be noted the netting was used in the stack. The steam pipes are along the order of the present day outside steam pipes and the exhaust pipe was separate to each cylinder, giving a very direct path for the escape of the steam from the cylinders. No deflector plate was used and the inside pipe projected into the smokebox below the top of the exhaust nozzle, and this acted, it would seem, in the same manner as the present day deflector plate. The stacks at this time were very long and the smokebox was not circular in form. The bottom part was rectangular, being bolted to the cylinders and the bottom of the frame. These engines were in service east of the Ohio river, the railroad not having been extended beyond

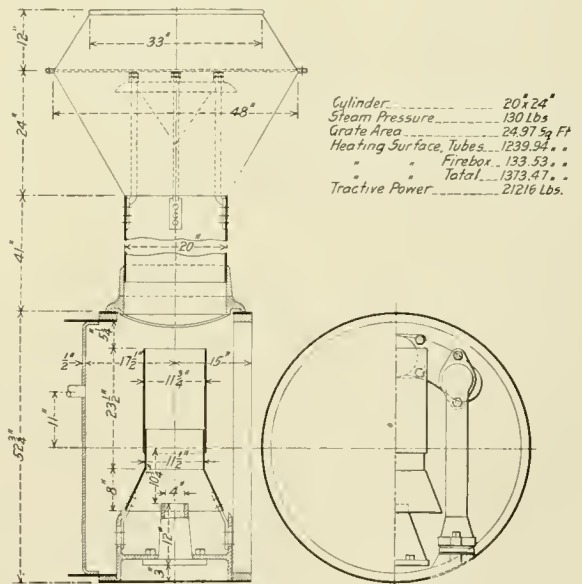

Fig. 2—Front End Used in 1873

and the netting is placed comparatively close to the top of the smokebox, this being done on account of the front end filling up. This arrangement also shows the adoption of the front end extension, which, it will be seen, is bolted to the smokebox proper. The arrangement used for getting out the sparks was the steam ejector, which blew the sparks, which were forced to the bottom of the smokebox by means of a bar inserted through the top handhole to one side of the locomotive. It would seem that the use of the deflector plate was not given



very serious attention, as this deflector plate did not fit tightly against the sides of the smokebox, having a 3-in. opening.

Fig. 4 illustrates the arrangement applied to a six-wheel switching locomotive at about the same time. It had dimensions as follows:

Cylinders .....	19 in. by 24 in.
Boiler pressure .....	150 lb.
Grate area .....	17.25 sq. ft.
Firebox heating surface .....	108.77 sq. ft.
Tube heating surface .....	1,249.74 sq. ft.
Total heating surface .....	1,358.51 sq. ft.
Tractive effort .....	22,093 lb.
Total weight of locomotive .....	97,700 lb.

This arrangement is similar to that shown in Fig. 3, except that the deflector plate has been made different at the top and the inside stack extension is placed closer to the center line of the boiler. The smokebox extension is riveted to the junction ring instead of being bolted in place. The means provided for getting the sparks out of the front end has been changed to a spark drop in the bottom.

It was realized with the arrangement shown in Fig. 3, where the deflector did not fit tightly against the smokebox, that the draft obtained was not satisfactory, and on this arrangement the deflector plate is brought tight against the sides; but the question whether or not this would result in the satisfactory burning of the fire not being definitely decided, the deflector plate was perforated with 1/2 in. holes at 1 1/4 in. centers. Also the necessity of having some means of getting to the top of the netting

the length of the smokebox extension has been increased from 18 in. to 30 in. The stack extension has been fastened tightly to the stack.

It probably will have been noticed that the boiler pressure has increased from 110 lb. in 1853 to 160 lb. in 1893, and the arrangement shown in Fig. 6 was used in 1903 on a class of locomotives which had the following dimensions and a boiler pressure of 205 lb.:

Cylinders .....	22 in. by 28 in.
Boiler pressure .....	205 lb.
Grate area .....	48.06 sq. ft.
Firebox heating surface .....	184.32 sq. ft.

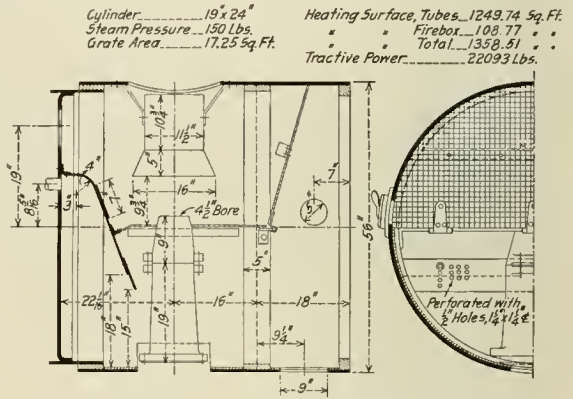

Fig. 4—Front End Formerly Used on a Six-wheel Switcher

Tube heating surface .....	2,662.92 sq. ft.
Total heating surface .....	2,847.24 sq. ft.
Tractive effort .....	42,168 lb.
Total weight of locomotive .....	193,500 lb.

It will also be noted that this engine was the first step towards the wide firebox. This front end arrangement was the diamond basket shape, very popular at that time. The exhaust base was reduced in length and the length of the smokebox extension was also reduced. The deflector plate was still perforated.

This arrangement resulted in a very free steaming engine, but the front filled up easily, which resulted in the basket

Cylinder .....	21" x 26"	Heating Surface, Tubes ..	1839.06 Sq. Ft.
Steam Pressure .....	165 Lbs.	Firebox ..	150.37
Grate Area .....	24.04 Sq. Ft.	Total ..	1989.43
		Tractive Power .....	31188 Lbs.

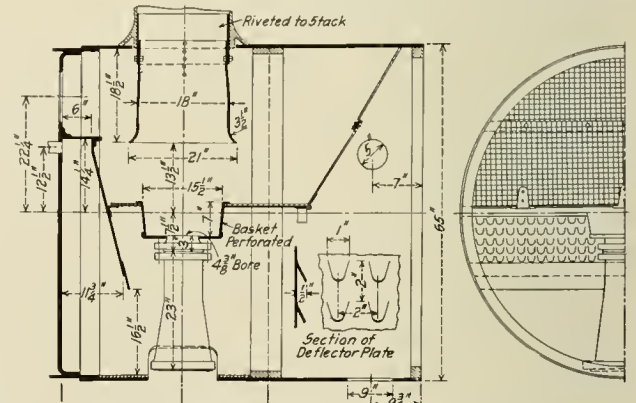

Fig. 5—Front End for a Consolidation Locomotive In 1893

burning out, causing considerable trouble. To overcome this, the arrangement shown in Fig. 7 was adopted after experiment. This front end was applied to a Consolidation locomotive having:

Cylinders .....	22 in. by 30 in.
Boiler pressure .....	205 lb.
Grate area .....	57.05 sq. ft.
Firebox heating surface .....	179.3 sq. ft.
Tube heating surface .....	2,594.78 sq. ft.
Total heating surface .....	2,774.08 sq. ft.
Tractive effort .....	42,168 lb.
Total weight of locomotive .....	220,370 lb.

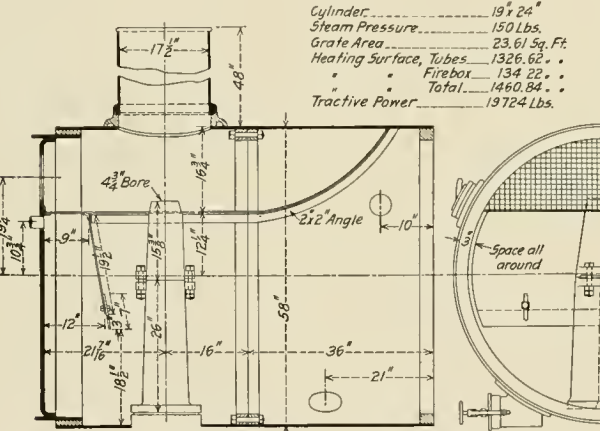

Fig. 3—Front End Used on a Ten-wheel Locomotive in 1883

was realized and the hinged trap was used. The height of the exhaust base and nozzle was considerably decreased, which, according to the records, resulted in a freer steaming locomotive, although the size of the exhaust nozzle with the arrangement shown in Fig. 4 is smaller than that shown in Fig. 3, the cylinders and boiler pressure being the same and the heating surface less in the latter arrangement.

In Fig. 3 it will be noticed that the length of the smokebox extension is 36 in., while in Fig. 4 it is 18 in.

Fig. 5 shows the arrangement used about 1893 on a Consolidation locomotive of the following dimensions:

Cylinders .....	21 in. by 26 in.
Boiler pressure .....	165 lb.
Grate area .....	24.04 sq. ft.
Firebox heating surface .....	150.37 sq. ft.
Tube heating surface .....	1,839.06 sq. ft.
Total heating surface .....	1,989.43 sq. ft.
Tractive effort .....	31,188 lb.
Total weight of locomotive .....	120,800 lb.

It will be noted that this arrangement was applied to a smokebox 65 in. in diameter, which is 9 in. larger than that shown in Fig. 4. The length of the exhaust nozzle has been increased while the nozzle has been reduced; the relation of the table netting to the center line of the boiler is practically the same and a perforated basket is used between the table netting and the top of the exhaust nozzle. The deflector plate has been perforated to a greater extent in rather a novel manner and

This arrangement marks the first step in a radical departure from the arrangements previously described. The deflector plate is not perforated. The tapered stack is used with inside extension. The mouth of the inside extension is of a much larger diameter and is belled. The table netting has been lowered below the center line of the boiler. The combined length of the exhaust base and nozzle has been materially reduced and a basket made of netting is used between the table netting

Cylinder.....	22 x 28"	Heating Surface, Tubes.....	2662.92 Sq. Ft.
Steam Pressure.....	205 Lbs.	" " Firebox.....	184.32 "
Grate Area.....	48.06 Sq. Ft.	" " Total.....	2847.24 "
		Tractive Power.....	42168 Lbs.

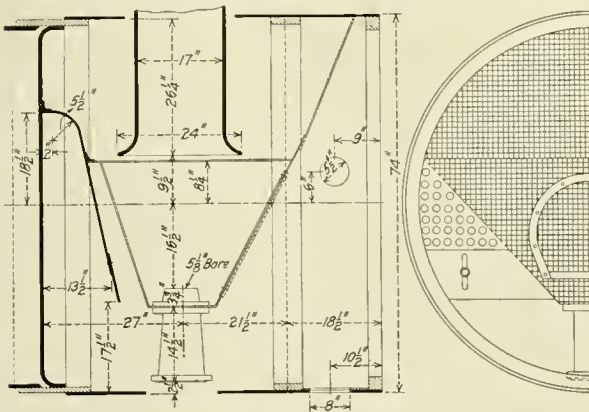

Fig. 6—A Front End Design of 1903

and the exhaust nozzle. The practice of riveting a smokebox extension to a junction ring has been discontinued, although the distance from the center of the exhaust to the front of the smokebox is practically the same. The amount of taper for the stack and the choke in the inside stack extension was obtained by means of draft gages with adjustable nipples which were located 12 in. apart, as shown in the illustration. These nipples were screwed in or out until the same amount of draft

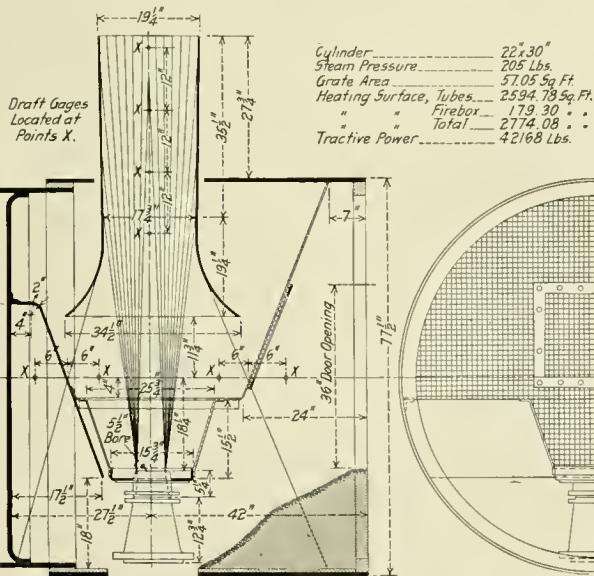

Fig. 7—Front End Designed to Overcome Difficulties Encountered in Using the Design Shown in Fig. 6

was obtained with all four gages, and by this means the necessary dimensions were obtained. The stack liner was made to these dimensions and applied, and after the application of the liner, the draft gages at the points marked X at top and bottom of stack, front and back of deflector plate and front and back of netting, all showed a uniform draft, a condition seldom obtained.

This front end was practically self-cleaning. After sealing the front end and running the engine for two weeks only the amount of sparks shown in the illustration were found in the front.

The writer has personally seen a locomotive, fitted with this arrangement, work in full gear for 27 minutes, and during this time the locomotive popped against the injector six times.

Comparing this design with the best arrangement from the Master Mechanics' tests in 1906, while it is not of the same diameter, it nearly checks with the recommended practice, with the exception of the amount of choke and taper. According to the recommendations, the choke in the stack should be .21 diameter plus .16 of the distance from the center line of the boiler to the top of the exhaust nozzle. Using this formula, with this arrangement, the diameter of the choke would be 19.1 in., while in the illustration it is shown as 17.75 in. The taper of the stack recommended is 2 in. to the foot, while that shown in the illustration is 3/4 in. to the foot. The distance from the center of the boiler to the top of the exhaust nozzle is recommended to be as great as practicable. In the arrangement shown it is 18 1/4 in. The height of the stack is also recommended to be as great as practicable, and in this case it is 27 3/4 in., being governed by clearance limitations. The

Superheated Engines		Saturated Engines	
Cylinders.....	26 1/2 x 32"	Heating Surface, Tubes.....	3708 Sq. Ft.
Steam Pressure.....	180 Lbs.	" " Firebox.....	228 "
Grate Area.....	70.5 Sq. Ft.	" " Total.....	3936 "
		Tractive Power.....	54587 "
		Cylinders.....	24 1/2 x 32"
		Heating Surface, Tubes.....	4189 Sq. Ft.
		Steam Pressure.....	205 Lbs.
		Grate Area.....	70.5 Sq. Ft.
		" " Total.....	5017 "
		Tractive Power.....	50184 Lbs.

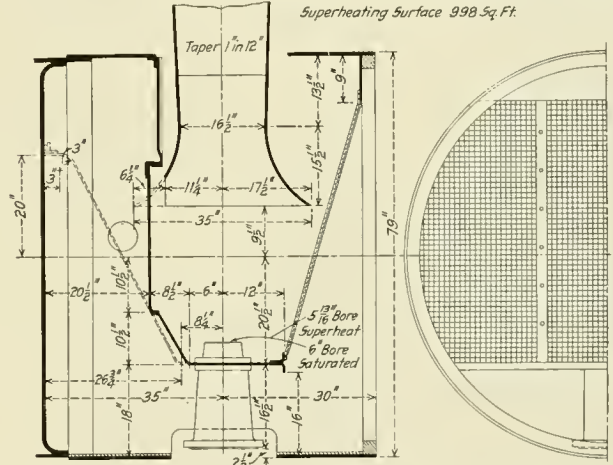

Fig. 8—Self-cleaning Front End for Saturated or Superheated Steam Locomotives

distance from the top of the smokebox to the top of the stack extension is recommended as .32 diameter, which would make this dimension 24.8 in., while the actual figure is 26.25 in. The distance from the choke to the bottom of the stack extension, according to the recommendations, is .22 diameter or 17.05 in., while in the arrangement shown it is 19 1/4 in. The length of the smokebox is recommended as .9 diameter, which would mean 69.7 in., while the actual figure is 69.5 in.

The writer believes that the recommendations made by the Master Mechanics' Committee are open to some criticism as regards the diameter of the choke and the amount of taper in the stack, when it is considered that when the Master Mechanics' tests were made, the fuel used was oil and no netting was used in the smokebox, which means that actual conditions in service were not obtained. When netting is used a greater amount of draft is required to produce a certain amount of draft in the ashpan than when the netting is not used, and it is on this account that the writer believes that the amount of taper as recommended by the Master Mechanics' Committee is too large.

The front end illustrated in Fig. 7 was designed from results obtained in service tests. This design is somewhat similar to



that developed by some of the western railroads burning Lignite coal, and the results obtained with its use were very gratifying.

Fig. 8 shows the design illustrated in Fig. 7 developed into a self-cleaning front end for both superheated and saturated steam engines, and, in the mind of the writer, represents the best arrangement of front end now in use. The tapered stack and inside stack extension with large bell mouth is retained. The exhaust base has been increased in length a sufficient amount so that the table plate will be the proper distance above the bottom of the smokebox. The distance from the center of the exhaust to the center of the smokebox has been reduced in length so that there is just enough room in front of the cylinder saddle to get a sling around the smokebox to lift the engine off the wheels with a crane.

Another feature of this design is that the table is placed between the exhaust nozzle and the base, so that any change in the exhaust nozzle will not necessitate the removal of the

very much smaller than that used in practice, the path of the escaping steam should be the same regardless of the diameter.

## DIVIDING THE CIRCUMFERENCE OF A CIRCLE

BY WM. H. WOLFGANG

A table for dividing the circumference of a circle into any number of equal parts, by means of chords, is given below. In the formula  $C = D \times X$ ,  $C$  is the length of the required chord in inches,  $D$  is the diameter of circle in inches,  $X$  is a factor depending upon  $N$ , and  $N$  is the number of equal parts into which the circumference is to be divided.

In using the table, find the desired value of  $N$  and substitute in the rule the value of  $X$  shown opposite in the table. The value of  $C$  thus found will be the length of chord required to divide

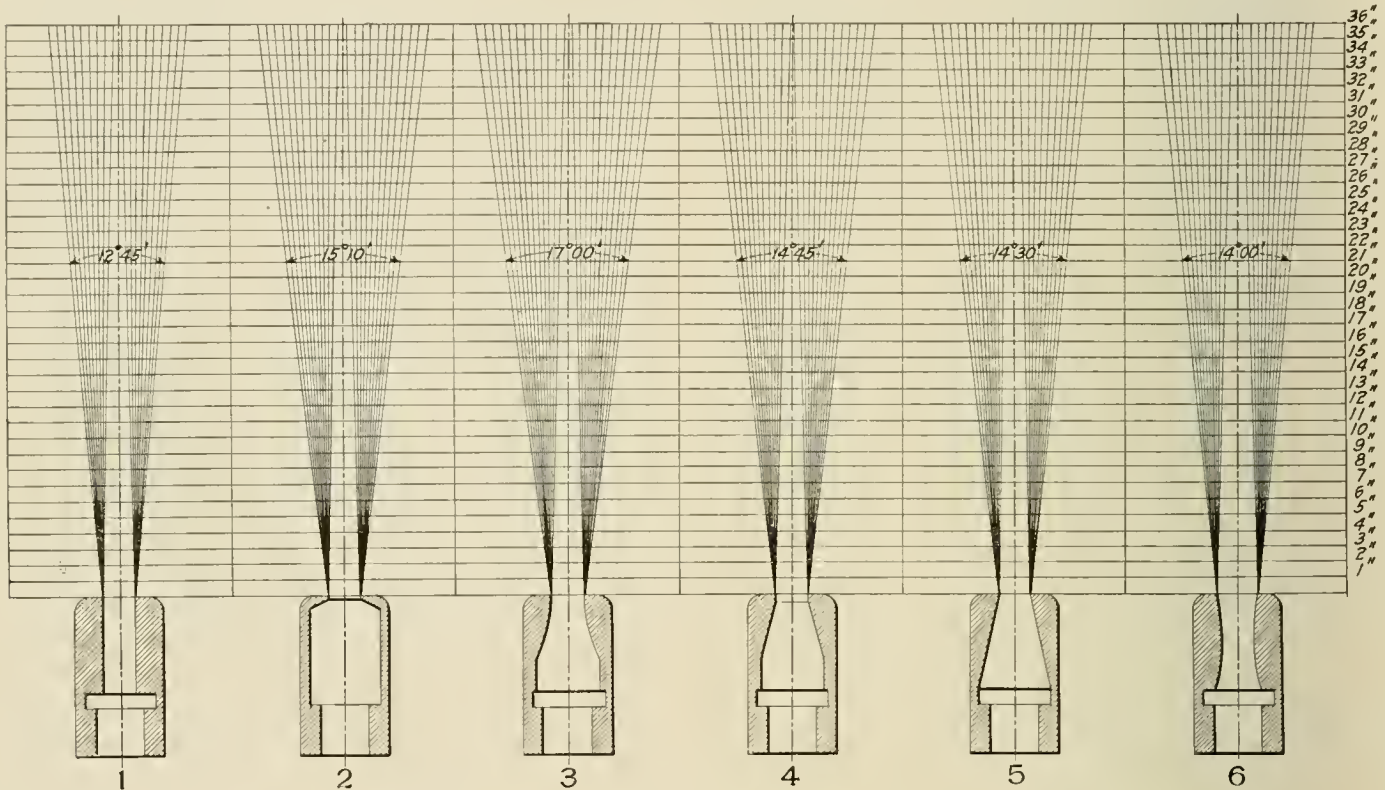

Fig. 9—Tests to Determine the Path of the Exhaust Steam from Different Types of Nozzles

table plate. This front end is in use on Mikado type locomotives of the dimensions shown in the illustration, the total weight of the superheater locomotive being 284,500 lb. and the saturated steam locomotive 276,050 lb. It gives very good results under all fuel conditions and is absolutely self-cleaning.

During the time of the development of the front end arrangement to the self-cleaning type, a standard nozzle pattern was adopted, the bore of which is governed by the size of the locomotive and the kind of fuel burned, and this one pattern answers for all of the heavier engines built since 1890.

While the arrangement shown in Fig. 8 is applicable to the heavier power, all of the front end arrangements are designed with the same relative dimensions and the results obtained on all classes of locomotives equipped with this arrangement have been gratifying.

The question very often arises as to the efficiency of different shaped orifices in the exhaust nozzle and Fig. 9 illustrates the diverging angles of steam passing through the nozzles shown, which may be of some assistance in this respect. The path of escaping steam was obtained by actual measurements with a constant back pressure, and while the area of the nozzles is

the circumference of the circle into the desired number of equal parts.

### FACTORS FOR USE IN DETERMINING LENGTH OF EQUAL CHORDS

N	X	N	X	N	X	N	X
1.....	.....	26.....	.12054	51.....	.061560	76.....	.041325
2.....	.....	27.....	.11609	52.....	.060379	77.....	.040788
3.....	.86603	28.....	.11197	53.....	.059240	78.....	.040267
4.....	.70711	29.....	.10812	54.....	.058145	79.....	.039757
5.....	.58779	30.....	.10453	55.....	.057090	80.....	.039260
6.....	.50000	31.....	.10117	56.....	.056071	81.....	.038775
7.....	.43388	32.....	.098018	57.....	.055089	82.....	.038303
8.....	.38268	33.....	.095056	58.....	.054139	83.....	.037841
9.....	.34202	34.....	.092269	59.....	.053222	84.....	.037391
10.....	.30902	35.....	.089640	60.....	.052336	85.....	.036955
11.....	.28173	36.....	.087156	61.....	.051478	86.....	.036522
12.....	.25882	37.....	.084804	62.....	.050649	87.....	.036103
13.....	.23932	38.....	.082580	63.....	.049845	88.....	.035692
14.....	.22252	39.....	.080466	64.....	.049068	89.....	.035391
15.....	.20791	40.....	.078460	65.....	.048312	90.....	.034899
16.....	.19509	41.....	.076549	66.....	.047582	91.....	.034516
17.....	.18375	42.....	.074731	67.....	.046872	92.....	.034141
18.....	.17365	43.....	.072995	68.....	.046184	93.....	.033774
19.....	.16460	44.....	.071339	69.....	.045515	94.....	.033415
20.....	.15643	45.....	.069756	70.....	.044865	95.....	.033064
21.....	.14904	46.....	.068243	71.....	.044232	96.....	.032719
22.....	.14232	47.....	.066793	72.....	.043619	97.....	.032381
23.....	.13617	48.....	.065401	73.....	.043022	98.....	.032051
24.....	.13053	49.....	.064073	74.....	.042441	99.....	.031728
25.....	.12533	50.....	.062791	75.....	.041875	100.....	.031411

# CAR DEPARTMENT

## BALTIMORE & OHIO MILK REFRIGERATOR CAR

The Baltimore & Ohio has recently placed four dairy refrigerator cars in milk service between points in Ohio and the Pittsburgh market, in the construction of which special attention has been given to proper sanitation. The new cars are remodeled from wooden postal cars, the work being done at the Mt. Clare shops of the Baltimore & Ohio, according to specifications approved by the United States Department of Agriculture. They will insure the arrival in Pittsburgh of milk from Chicago June-



Side Doors and Bulkhead of Baltimore & Ohio Milk Refrigerator Car

tion, Painesville and intermediate points at a temperature of 45 deg. after a run of five hours. It is also claimed for the cars that they will retain a uniform temperature for 48 hours with one icing when the temperature outside the car is as high as 50 deg.

These cars have a length of 60 ft. over the body and are carried on six-wheel passenger trucks, the external appearance harmonizing throughout with other passenger equipment. Each car has two ice bunkers 2 ft. 5 in. in width, extending across the ends and is divided into two refrigerator compartments, each 22 ft. 6 7/16 in. long, and having a capacity of 130 ten-gallon milk cans,

by bulkheads across the car on either side of the center doorway. Each ice bunker contains six brine tanks, which are filled with ice and salt through hatches in the roof and are arranged to drain automatically when the brine reaches about three-quarters the height of the tank. A greater depth of brine may be retained if desired, by closing a three-way cock accessible through a hole in

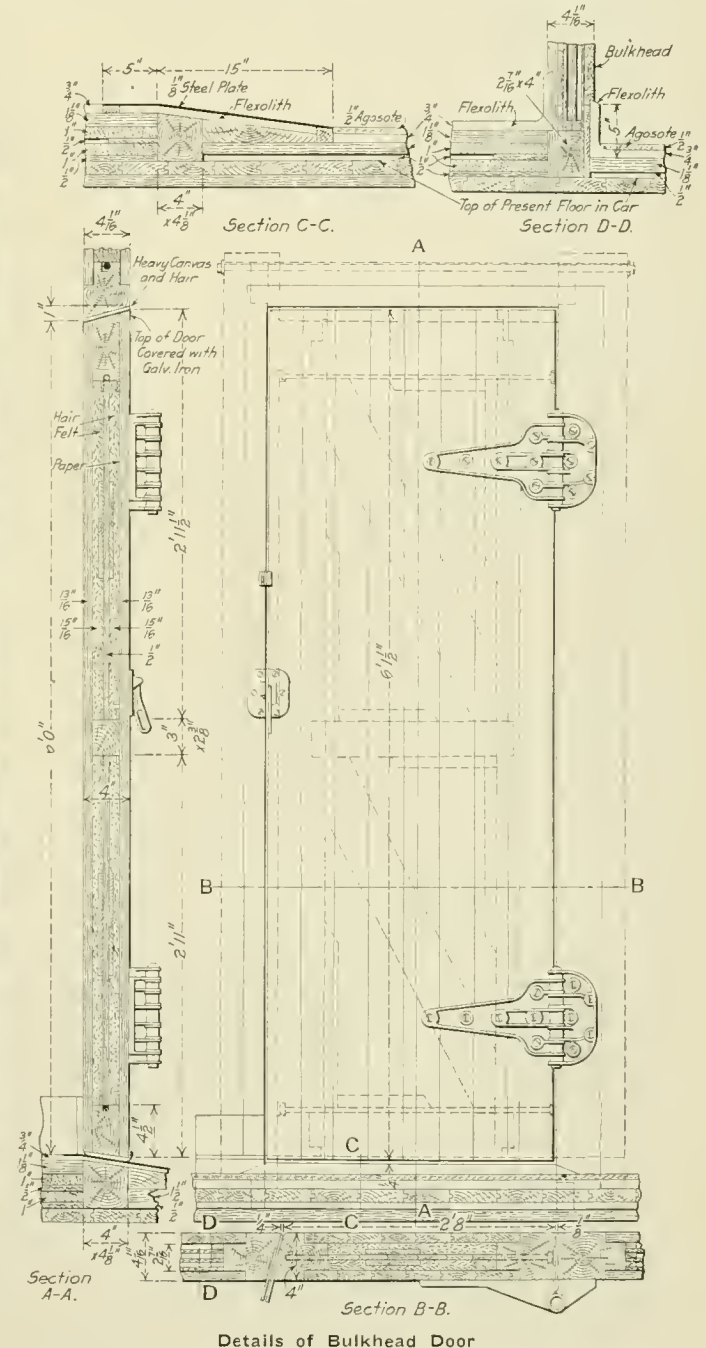

Details of Bulkhead Door

the bunker bulkhead. Handholes are provided near the bottom of the tanks through which they may be drained. The bulkhead has an opening in both top and bottom covered with heavy wire mesh, these openings furnishing a means of circulation to and from the refrigerator compartment; and the tanks are so placed that both sides are accessible to circulation, thus providing a



maximum radiating surface. The siphon which fixes the depth of brine in the tanks is shown in one of the engravings.

In remodeling these cars practically no change was made in the original construction, the insulation and interior finish of the

of 3/4 in. Flexolith, 1/2 in. air spaces being provided between layers of the cork board and the sub-flooring. The Flexolith floor is flashed up to a height of 5 in. all around with fillets in the corners. Across the car at the bulkhead in front of the brine tanks a gutter

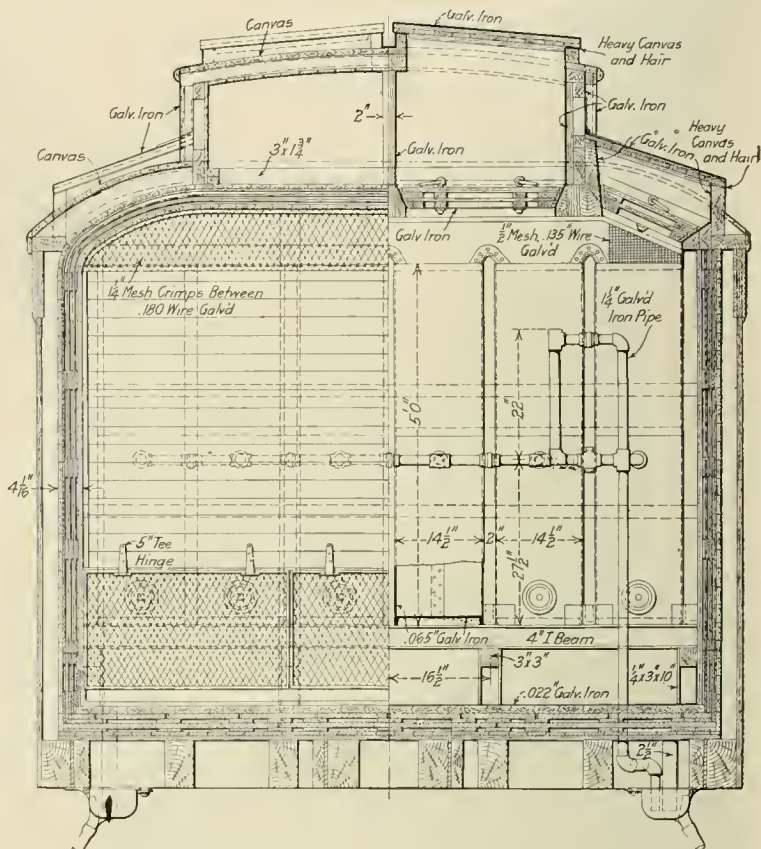
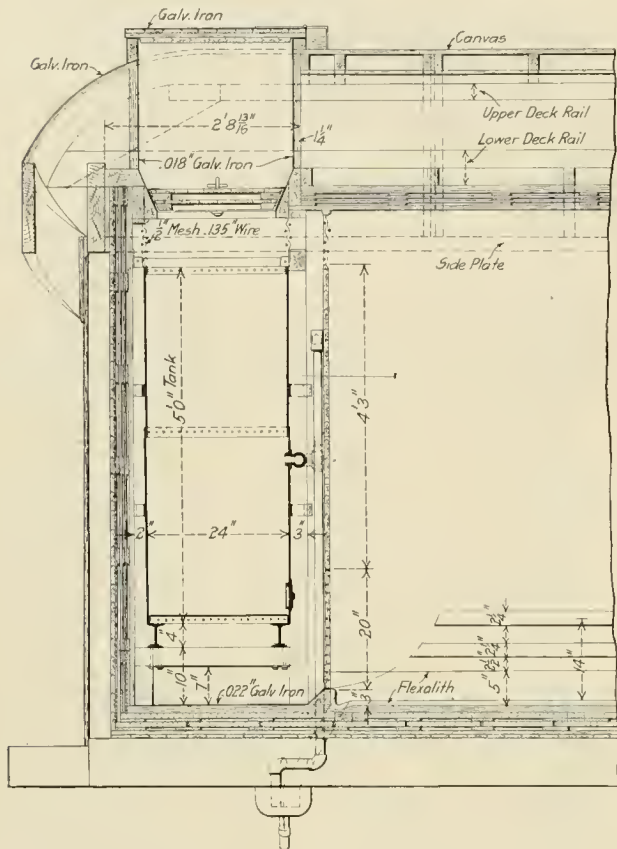

Sections Through the End of the Car Showing Arrangement of Brine Tanks

refrigerator cars being applied above the original finish of the postal cars. The floor insulation consists of two layers of 1 in. cork board and a 1 1/8 in. top floor, above which is applied a layer

with adequate drains is formed in the Flexolith to give proper drainage. The floor may thus be flushed whenever the cars are cleaned and left in a thoroughly sanitary condition. In the center



Refrigerator Car for Milk Traffic on the Baltimore & Ohio, Rebuilt from a Postal Car

compartment opposite the side doors Agasote is applied over the Flexolith to take care of the excessive wear due to the handling of milk cans. This covering may be easily removed.

The sides, ends and ceiling are insulated with three courses of Phoenix car insulation, both sides of each course being covered with paper stitched through, and air spaces being provided between the layers. The whole is covered with 13/16 in. yellow pine sheathing over which a coat of white enamel paint is applied. Along the sides near the bottom are applied two fending strips to prevent the milk cans from scarring the inside finish of the side walls. The clerestory is ceiled off from the body of the car and the ventilators in the upper deck have been closed up, thus forming a dead air space above the refrigerator sections where radiation is greatest. The hatches are provided with plugs at the bottom, as well as covers at the roof, which provides against undue radiation from the bunkers.

The cross bulkheads at the center of the car are 4 1/16 in. thick and are provided with refrigerator type doors which effectively seal the refrigerator compartments from the center section. These doors swing back against the bulkhead when loading or unloading the car. The side doors are in two parts hinged to swing

Make it the duty of some person to see that your inspectors do not allow any cars to get out on your line that are not in good condition, and see that all agents along your line have a good general knowledge of a car and the M. C. B. rules, more especially the loading rules. This will save a great many transfer orders being given against your line.

The M. C. B. rules have as many interpretations as the father has excuses for taking his hopefuls to the circus, each person will claim that his interpretation is the only correct one. I have no doubt that some of you will say this is wrong, that there can be only one interpretation to any one rule.

Unfortunately there never have been any rules or laws so plain but what somebody can and will misunderstand them or see something in them that someone else does not see. Sometimes this is an honest difference of opinion and sometimes it seems that it is a notion taken with the view to see how different they can be from other people.

Take a case out on your line, where there are two inspectors, one inspector working for your line and one representing the other line. The inspectors have gotten into a disagreement regarding the condition of a car. The car foreman will

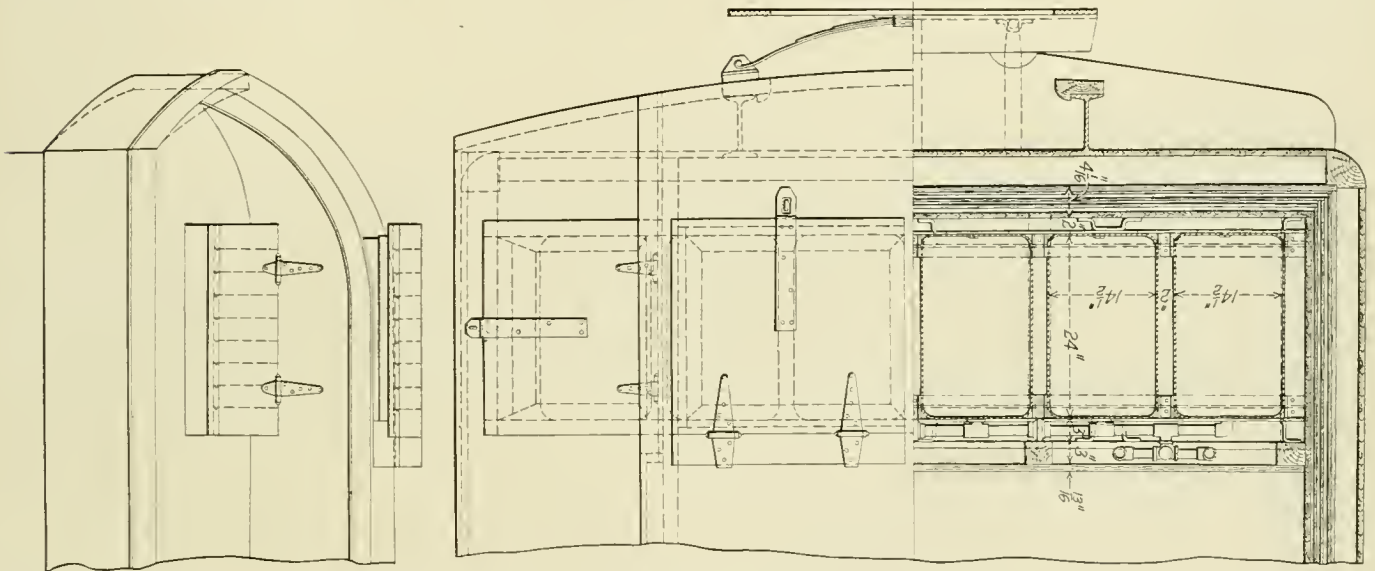

Half-Sectional Plan and Elevation Showing Brine Tanks and Hatches

inward, having glass panels in the top, which with glass sash in the upper deck, gives ample light for the center section.

The Department of Agriculture is showing much interest in this equipment. Daily records of the temperature of the cars are being taken, together with data as to the quantity of ice consumed and other information bearing on dairy product transportation.

## INTERCHANGE OF CARS\*

BY H. BOUTET

Chief Interchange Inspector, Cincinnati, Ohio

It is of very little use to receive a car of freight at one point, haul it over the line and then have it refused by some other line, as the railroad has not completed its service until it has delivered the car to a connecting line or to its destination. While a great deal has been accomplished toward improvement in the getting of cars through terminals, much is yet to be accomplished. A great deal more could be done by seeing, when cars are empty, that all of them are put in such a condition that they are safe to haul the commodities they are built to carry, or at least such commodities as originate on your line, to any destination within reason.

go to that point and ask his inspector what the trouble is, and the inspector will tell his foreman that the car has three broken sills. The foreman will examine the car and find three of the sills with a crack from 1/2 in. to 1 in. near the transom and he will tell his inspector that these are not bad enough for repairs. His inspector's answer to this will be that he has been compelled to card for such defects as these all the time since the present rules were in force, and the other inspector's foreman upholds him in setting out such cars and will not accept the cars without a defect card. The foreman will take the side of his inspector and tell his master mechanic that the car should be carded and that the defects are of such a nature that they have been carded for all the time. Finally the case is settled by the other fellow carding the car, after it has been delayed some three or four weeks. This, of course, makes the inspector of the delivering line angry and causes him to become more technical in his inspection to enable him to get even with the other line, while the inspector who gains his point, sticks a feather in his hat and says, "I told you so." This delay to cars is the worst enemy the transportation department has to fight.

Some people will tell you that, according to M. C. B. rules, it is necessary for the delivering line to inspect and set out all cars for repairs or transfer and card for delivering line defects that are safe to run before the cars are delivered. Others will tell you that you must set all of your cars for interchange on

\*From a paper read before the Southern & Southwestern Railway Club, Atlanta, Ga., September 19, 1914.



a certain or delivery track, when the cars will be inspected by the receiving line and after inspection the delivering line must come back and take out all of the cars for repair or transfer. Others will tell you that what is known as Twentieth Century Inspection is M. C. B. rules.

Now let us see if we cannot get at a common understanding of this particular matter. The preface of the M. C. B. rules says in substance, that car owners are responsible for ordinary wear and tear in fair service; railroads handling the cars are responsible for damage done by unfair usage, derailment, accident, etc. The rules then go on to define a large number of defects in accordance with the preface.

The M. C. B. rules are given us as a basis on which to work. The writer takes the stand that it does not matter where a car is inspected; whether in the delivering or receiving line's yard, as may be agreed upon by the roads interested; sometimes local conditions determine this question so there can be no hard and fast rule about it. It is understood that the delivering line is held responsible for any damage that may have been caused to cars by unfair usage, derailment or accident, or any missing material that cannot be charged to the owners of the cars in interchange.

Let us take the situation at Cincinnati. The majority of interchange is made through switching lines or through two or three yards by the delivering line, the distance between some of the delivering line and receiving line yards being 26 miles. There are several methods by which inspection and interchange could be made, all of which the writer claims are within the scope of the M. C. B. rules.

*First.*—It could be made by the receiving lines putting their inspectors in the delivering line's yard and after the cars are side carded, inspecting and marking out such cars that they want repaired, transferred or carded. Cars passing the inspectors as O. K. for service could be switched out and delivered to the receiving line.

*Second.*—Cars could be inspected by the delivering line's inspectors and cars that they think should be repaired or transferred, for defects that they think should be cared for, should be carded and delivered to the receiving line.

*Third.*—The inspectors could be placed under the chief interchange inspector, and cars inspected in the delivering line yard; cars that are required to be set out could be marked out, those requiring repairs could be repaired, those requiring transfer could be transferred and those requiring cards could be carded.

*Fourth.*—Cars could be given a safety inspection in the delivering line yard by the delivering line's inspectors to see that they are safe to go to the repair or transfer track of the receiving line. When they are delivered in the receiving line's yard they could be inspected by the receiving line's inspectors, cars that require repairs or transfer could be set out for the necessary work and the cars requiring cards could be carded.

Now let us see the advantages and disadvantages of these different plans.

*First system.*—It would be necessary for the lines to have twice as many inspectors, or more than would be required under the other plans, as no road would agree to have a car inspected in a foreign yard and then switched and handled by a foreign road, without its again being inspected when received in their yard. You would have the advantage of having all bad order cars set out in the delivering line yard, consequently, you would only receive good cars or only such bad cars as were made such after inspection.

Again, it should be taken into account that no inspector would take any responsibility if he was placed in the delivering line yard; if there was any question at all he would set the car out. His foreman would not take any great exceptions to this, for if the delivering line foreman came to him and told him that his inspectors were too close, the only answer would be that they were "not any closer than your inspectors, for your inspectors are doing the same in my yard, and when you have your in-

spectors set out only such cars as should be set out, I will have my inspectors do the same." The consequence would be, if you did not have a chief interchange inspector or assistants located in each yard both day and night, your line would be blocked in 24 hours with cars that the receiving line's inspectors had set out for repairs or transfer, when in fact a great number of them should not have been set out. You have delayed freight, caused extra switching and consequently created additional expense, and also created a feeling with the shipper that you had not attempted to give him the proper service.

*Second system.*—It has never been found that the delivering line will inspect and card all cars that the receiving line wants carded or set out all cars that the receiving line thinks should be set out, either for transfer or repairs, nor will they card all cars for defects that the receiving line wants carded. This system has been tried at every large interchange point in the country and has never proved satisfactory. You have all of the work to do over, as you are not satisfied that the other fellow has given you all that you should have had and as you have to answer for the safety of equipment going over your line, you want to know positively that it meets all requirements and therefore will have your own men inspect the cars as they come to you.

*Third system.*—This does not always prove satisfactory as the men you employ are under another man's jurisdiction and supervision and you are not always able to get the desired results, as the instructions that you require for your particular line are not always carried out in the manner you desire, the instructions issued to inspectors being of a general nature and about on a par with what all the roads require. In this way you have your work to do over for about the same reasons as given in the reference to the second system.

*Fourth system.*—This has some disadvantages, but in the writer's opinion has a great many advantages over the other systems. You have the disadvantage of bad order cars coming to your line either for repairs or transfer, which is offset by the cars in the same condition going from your line to the other line.

The advantages are numerous. You have the advantage of having your own inspectors in your own yard directly under your own supervision and you can require them to use their judgment, according to the instructions given by you in the marking out of cars for repairs or transfer.

Every car that they mark out is brought to the immediate attention of the car foreman and for every car that they mark out that should not be marked out, you have the remedy which you can apply directly. The consequence is that they do not mark any cars out that you do not want marked out and in this manner save a lot of switching and confusion. Again, if a car should have a cotter key out or require other slight repairs, which the inspectors could make in less time than they could mark the cars out, you will have them make these repairs; but if the car was in the other person's yard the inspector would claim that he was sent there to inspect cars, not to repair them.

The fourth system, as described above, is the way that the interchange is done at Cincinnati, and it is believed to have accomplished the best results, keeping the cars moving with a minimum loss of time and not setting cars out unnecessarily, only setting out such cars that are liable to cause damage. The inspectors in the receiving line yard card for all defects on cars that they do not wish set out.

The assistant chief interchange inspector visits each yard each day and cards all cars set out for repairs, combinations and heavy defects. This method of carding has been in effect a little over two years and while there have been some cases where the inspectors have been wrong, where we have been compelled to give rebuttal cards to straighten the trouble, I have the first case to find where the inspector wilfully misused the cards. There is no set back of cars for bad condition except on instructions of the chief interchange inspector, consequently the number of set back cars is a minimum.

# JERSEY CENTRAL STEEL PASSENGER CARS

## Coach and Combination Car, 63 Ft. Long Over End Plates and Carried on Four Wheel Trucks

The Central Railroad of New Jersey has recently placed in service 67 steel coaches and nine steel combination cars built by the Harlan & Hollingsworth Corporation, Wilmington, Del.

tween the platform end sills. The web plates are spaced 18 in. apart and are 2 ft. 4 in. deep for a distance of 10 ft. 8 in. on either side of the center line of the car, tapering to 18½ in.

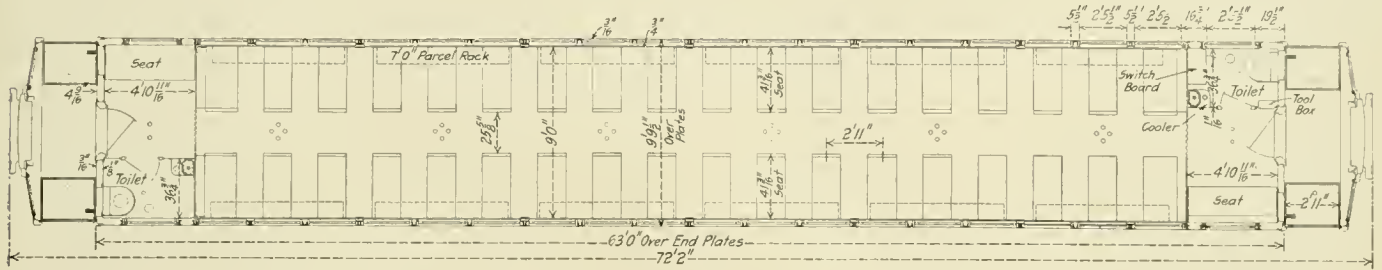

Floor Plan of the Coach

These cars are 63 ft. long over the body end plates and 72 ft. 2 in. long over the buffers, the truck centers being 49 ft. apart. The coaches have a seating capacity of 78, while the combina-

tion cars will seat 51 persons, and have a baggage room 22 ft. 4½ in. long. The framing of both types of car is similar, and the description which follows will be confined to the coach.



Steel Combination Car for the Central of New Jersey

tion cars will seat 51 persons, and have a baggage room 22 ft. 4½ in. long. The framing of both types of car is similar, and the description which follows will be confined to the coach.

### UNDERFRAME

The principal member of the underframe is the center sill, which is of the built up fishbelly type, and extends through be-

½ in. top cover plate 59 ft. 7¾ in. long. The side sills are 6 in. by 3½ in. by 7/16 in. angles.

The body bolsters are built up of 5/16 in. pressed diaphragm, with a ½ in. by 20 in. top cover plate extending the width of the car, and a ¾ in. by 16½ in. bottom cover or tie plate, 9 ft. 10½ in. long. There are two crossbearers placed 5 ft. 8 in. from the center line of the car, and two intermediate crossbearers

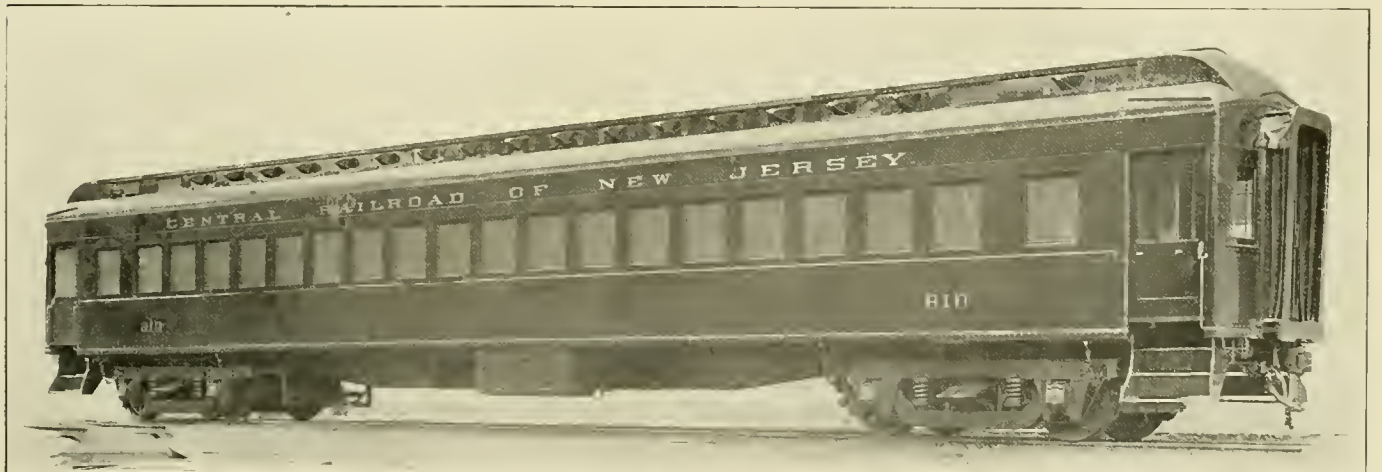

Steel Coach for the Central of New Jersey



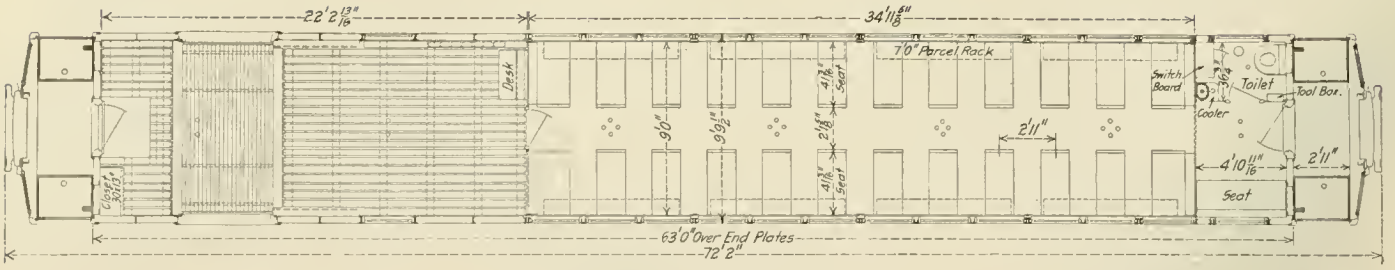

Floor Plan of the Combination Car

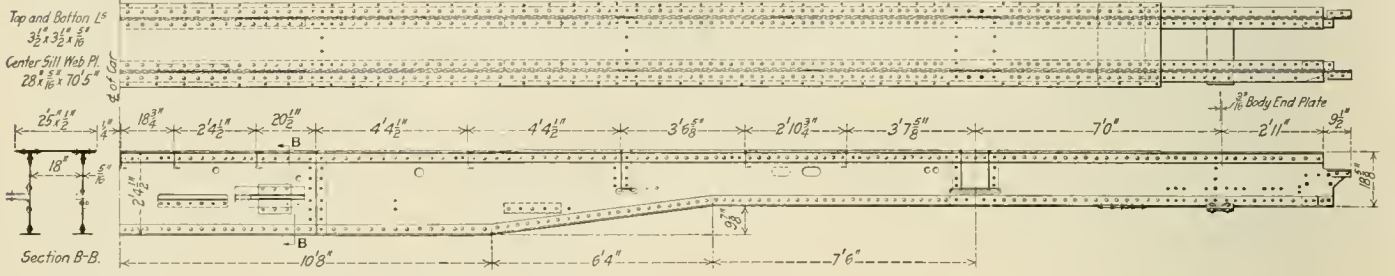

Steel Center Sill Construction Used in the Underframes

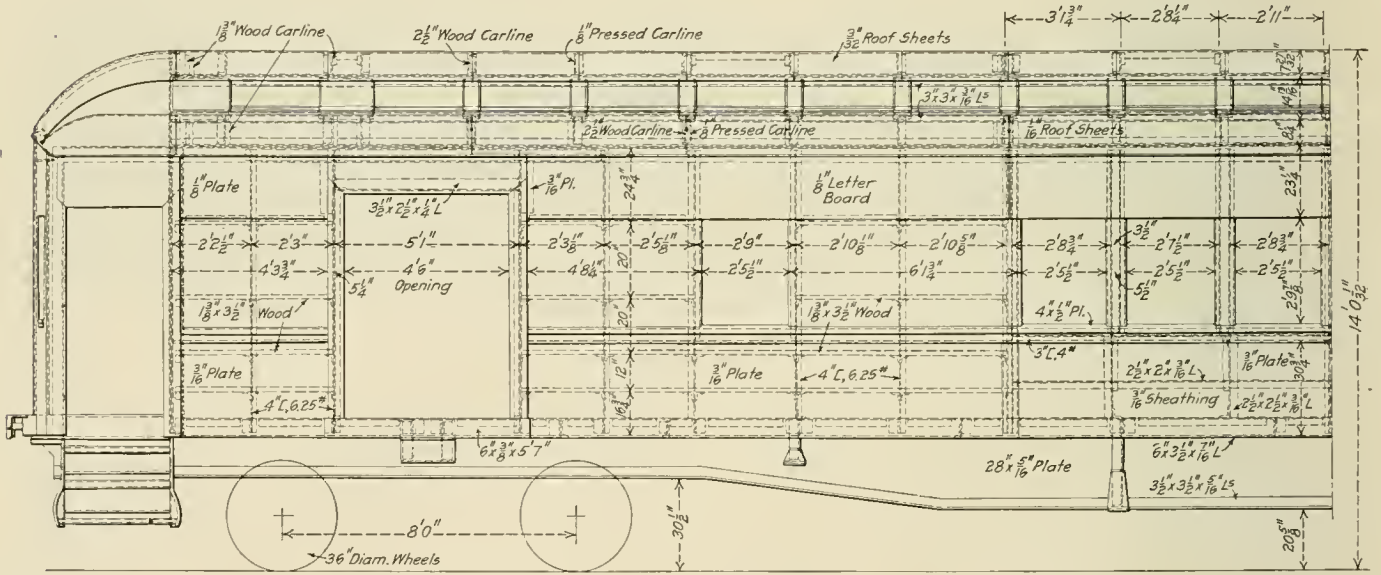

Arrangement of the Framing in the Car Body

are placed 8 ft. 9 in. beyond these, and 10 ft. 1 in. from the center line of the body bolsters. The crossbearers are all built up of 5/16 in. pressed steel diaphragms, a 9 in. by 3/8 in. top cover plate being used on all four of them, and extending the full width of the car, while the main or center crossbearers have tie plates 3/8 in. by 6 in. and 5 ft. 9 in. long, and the intermediate

upward riveted between them. Yellow pine fillers are placed between the channel uprights and between the saloon bulkheads of the car for the purpose of attaching the interior wood trim. The side sheathing is 3/16 in. steel plate, while a 1/8 in. plate runs the length of the car body over the window. The side plate is a 5 in. by 3 in. by 5/16 in. angle with the 5 in. leg down-

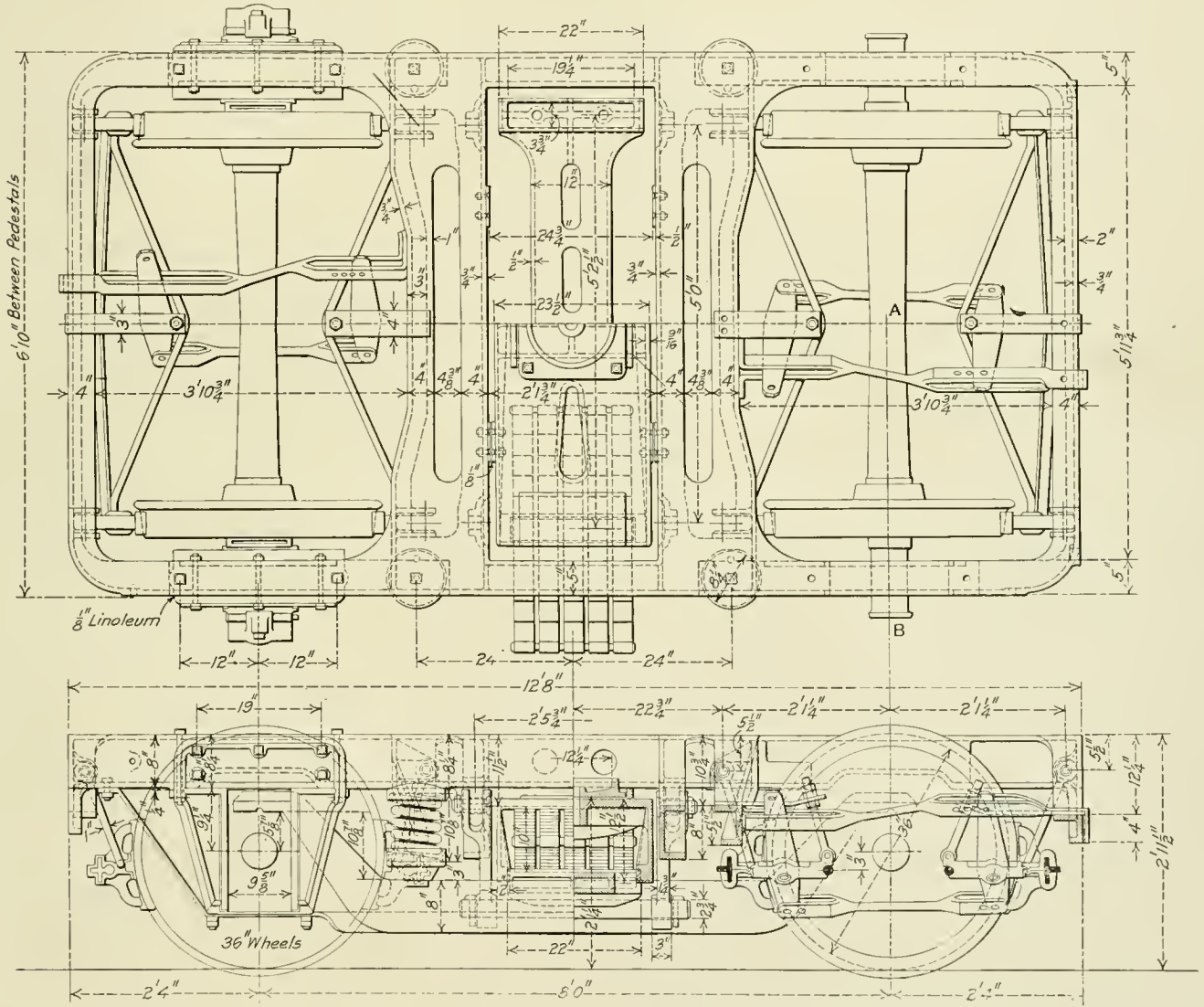
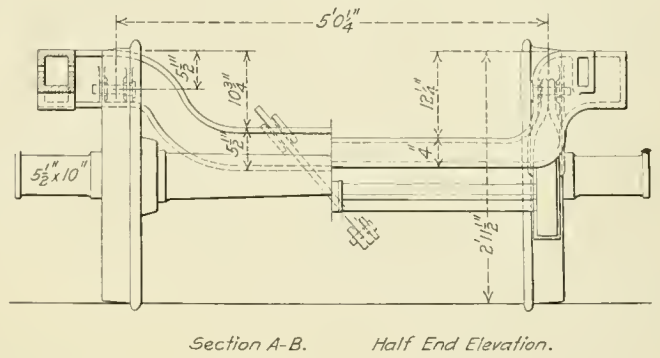
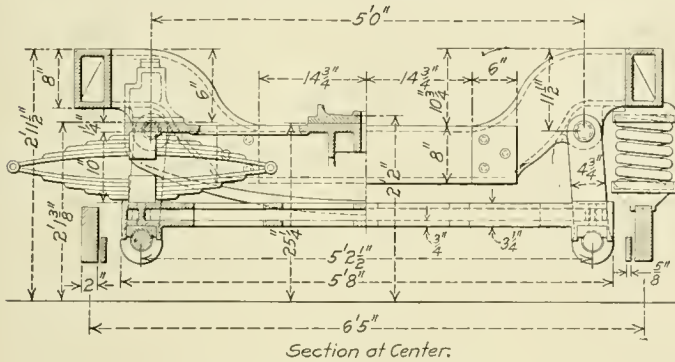

Four-Wheel Steel Truck with Clasp Brake Rigging Used on the Central of New Jersey Steel Cars

crossbearers 5/8 in. by 6 in. tie plates, 5 ft. 6 in. long. The cross ties or floor supports are 6 in., 8 lb. channels.

BODY FRAME

The side posts are 3 in., 6 lb. channels, and the belt rail consists of a 4 in. by 1/2 in. bar outside, and a 4 in. by 1/4 in. bar inside, with a 3 in., 4 lb. channel separator with the back turned

ward and riveted to the side posts; to the 3 in. leg there is riveted a 5 in. by 1/4 in. plate, to the inner edge and on top of which is riveted a 2 1/2 in. by 2 1/2 in. by 1/4 in. angle.

ROOF

In the roof construction 1/8 in. pressed steel car lines are riveted to the side plate and to the ventilator rail or deck side









four small stove bolts and the lower edge is weighted with a piece of steel bar, thus ensuring the full area always being in view regardless of wind conditions. This is an important feature, as the ordinary flag attached to a perpendicular mast hangs limp when the wind is not blowing, and if attached to a stick that is horizontal the flag may not be very conspicuous if the wind is blowing strongly from the direction of the observer. This device is of equal service at night, the only change required being to wrap the flag around the cross bar and hang a lantern



Blue Flag Holder Being Placed on a Rail, and After It Is in Position

over the bar, the folds of the flag serving to prevent the lantern from creeping off.

One of the most important advantages of this flag holder is the making possible the enforcement of rules requiring that flags be located a specified distance away from the car to be protected. This is important, as flags displayed against a dark object, such as a car painted black, are not as conspicuous as they would be if placed some distance in front of it.

**NEW METAL FOR BUSHINGS.**—Graphalloy, a new metal, which has recently been produced for the construction of self-lubricating bushings, and which is pure graphite impregnated under pressure with either babbitt, lead, bronze or copper, has the following mechanical properties:

Increase of weight due to impregnation, percentage.....	150
Percentage of metal in graphalloy by weight.....	60
Percentage of metal in graphalloy by volume.....	25
Compressive strength of graphalloy.....	14,000 lb. per sq. in.
Modulus of rupture.....	12,500

**IMPROVING THE BURNING OF COAL.**—There has recently been put upon the market in Germany quite a flood of preparations for the purpose of making a brew in which coal or coke is to be wetted before being put upon the fire. The alleged result of using these preparations is that the coal burns more readily and that there is a great saving in the amount of fuel required. Herr T. Oryno, of the laboratory of the Berlin Fermentation Institute, has analyzed a number of these preparations and found them to consist of various salts such as sulphate of magnesia, sulphate of soda, common salt, nitrate of soda, and so on generally with a small proportion of oxide of iron. He concludes that they cannot have the effects attributed to them.—*The Engineer*.

## THE GREATEST WEAKNESSES IN BOX CARS\*

BY R. P. BLAKE

Master Mechanic, Northern Pacific, Dilworth, Minn.

The box car as developed in this country has two principal functions—the transportation of material and the protection of its contents from loss or damage by theft or from the action of the weather. Its development from the car of 30 to 33 ft. length and a capacity of 20 to 25 tons and 1,500 to 1,650 cu. ft., with wooden roof, oak sills and short draft timbers, to the modern car of 36 to 40 ft. length, with a capacity of 40 to 50 tons and 2,750 to 3,000 cu. ft., with metal covered roof, steel underframes and reinforcements of steel in various parts, has been the result of the changes that have taken place in railroad operation. Between these two types of cars are those with many variations in size, capacity and minor details of construction which constitute the greater number of cars that are in actual service at the present time.

Box-car construction in this country in the past has suffered perhaps more than any other single item in railroad development from the blighting influence of first cost; but today it is generally understood that while first cost must not be lost sight of, yet cars which, due to cheapness in construction, are not of ample strength, will in actual service produce operating costs in the accounts of maintenance, loss and damage to contents, and delays to shipments that far overbalance the saving in construction. Again, admitting that there is an increase in the cost of hauling freight as the dead weight of the car increases, this is soon wiped out by the increased earning capacity secured by having a car that very rarely goes to the repair track and only in case of wreck has to be sent to a shop.

The fundamental principle underlying all satisfactory construction is a durable foundation, and this applies with special force to box cars. The underframe construction is today the weakest part of a great majority of box cars in service, and until it is reinforced to provide a rigid base upon which the body can be securely fastened, our troubles will continue in ever-increasing numbers. The increased necessity for larger train units to reduce operating costs has resulted in a great increase in the shocks met in daily service, and it is these heavier shocks that, frequently repeated, sooner or later shatter the draft rigging connections to the underframe of the car and loosen the roofs, posts and braces. The load on a bridge and the resultant stresses can be readily determined by accurate calculations and the proper factor of safety provided. In a similar manner, many parts of a locomotive can be designed so as to insure satisfactory results. But box-car construction is quite different, and the necessary strength of a car frame or body to withstand properly the various service shocks, which in many cases are only generally known, is largely a matter of careful observation of service conditions and must be based more on experience than calculation.

The experience with steel cars designed for handling coal and ore has demonstrated that it is possible to construct a car that can and will meet fully the requirements of modern train service, and it is this type of construction that is now generally recognized as necessary to obtain a satisfactory car. Again, the introduction of steel underframe construction so generally in new work has resulted in concentrating the effects of service shocks upon the weaker wooden underframe cars in a train and the deterioration of wooden cars is increasing in a marked degree. The steel center sill that is interchangeable with wooden sills, is the only proper remedy for this defect, and the resultant stiffness will more than pay for the slightly increased cost. A better method of securing the draft rigging is provided, and a reduction made in the straining of the body that ordinarily comes from a weak underframe that will not carry the load.

\*Awarded the first prize of \$50 in the car department competition which closed October 15, 1914.

Having provided for this, the greatest weakness in box car conditions, by making a car that should be available for transporting material a maximum proportion of the time, the question of the protection of the contents from damage must also be considered. The class of material to be handled is of vital importance, and weakness in construction develops accordingly; but generally speaking, the order in which it occurs is, first in the roof, next in the side doors and fixtures, and last in the door posts and end posts.

The weaving of a box car in service, due to inequalities in the track and the inertia of its own superstructure, especially under switching shocks, has been greatly increased in the larger cars of more recent construction, and can only be overcome by greater strength in design. The roof frame must not only be securely fastened to the body, but must be firmly cross braced, as without this cross bracing the best of waterproof covering will become loosened and leak and often in case of severe wind be torn entirely from its place. Various forms of steel carlines are giving excellent service, as they can easily be applied to fully meet the requirements of the service. The present wooden roof construction can be greatly reinforced with little additional cost by making the surface circular and fastening the roof boards diagonally across the car, which provides a light yet very strong construction and gives a proper foundation for the weather-proof covering.

One of the greatest sources of loss of contents from box cars by theft is directly chargeable to side doors and fixtures. Doors which do not slide freely are soon damaged by shippers in opening and closing, and it is hard to keep such doors properly closed on empties, with the result that the impact of switching and service shocks causes frequent damage. Roller fixtures should be secured so they cannot get out of place under jars from service shocks and should have proper clearance so that the door cannot bind. Bottom door guides should be securely fastened with nuts riveted over so that they cannot be readily removed and should have a flange high enough to prevent any possibility of the door, even when slightly damaged, swinging out from the side of the car. Front door stops should be of metal, to provide a rigid connection for the hasp and fixtures and proper reinforcement for the door post. The hasp fastener should be secured directly to the frame of the door, as otherwise the boards of the door will be torn from the frame.

Cars used to transport lumber and similar commodities, also for bulk shipments, such as grain, coal, lime, etc., are liable to additional strains from shifting of the load and the bulging effect which causes frequent failures of end and door posts. This is one of the greatest causes of loss and damage claims in bulk grain shipment and a frequent cause of delay in lumber shipment. The only way to provide proper strength in end posts is to have them held in place by substantial pocket and cap castings, securely fastened at the top and bottom to the frame; the posts should be reinforced by using either a metal fitch plate or an I-beam. The end lining should not be less than  $1\frac{3}{4}$  in. in thickness to properly distribute the shocks over the entire end.

The bulging of door posts is not as a rule the result of such severe shocks as come on the end posts, but weakness at this point is common and difficult to determine from an outside inspection before loading. The pocket at the bottom of the post should be particularly strong and securely fastened to the side sill in such a manner as to prevent the post tipping out.

These items cover the chief causes of loss, damage and delays on account of weakness in box-car construction. The remedies proposed will give a car of sufficient strength to continue almost constantly in service with low cost of maintenance and very few claims for loss or damage that can be charged to the construction of the car. The good will of the shipper can best be secured and held by removing the causes of loss and damage, and it is one of the factors that must be seriously considered in determining the cost and efficiency of a box car.

## WOODEN CARS IN FREIGHT TRAINS

On page 581 of the November number there was published an abstract of a paper on "Wooden Cars in Freight Trains," read before the Canadian Railway Club, Montreal, Que., October 13, 1914, by G. E. Smart, Master Car Builder, Intercolonial Railway, Moncton, N. B. The following is taken from the discussion of the paper:

W. O. Thompson, District M. C. B., N. Y. C., Buffalo: The draft gear problem is one of the most serious and expensive ones on old cars all over the country. I have noticed when cars were damaged that were equipped with the modern draft gear, it was not the gear that was damaged, but the rest of the car, showing that our friends in the draft gear business are fully alive to modern requirements and have the gear for you any time you want it.

As to the matter of rough switching in yards, yard motive power has increased in capacity in the same ratio as road motive power, and time is a great factor on railroads. We cannot any more reasonably expect our old freight car equipment to stand the switching service in yards any more than it will stand the work out on the road.

The wooden car has not much of a chance. It is not expected that it will have. The only thing that can be suggested at the present time in handling wooden cars is to keep them in the rear of the train, but there are a good many arguments against that practice. It takes time and costs a good deal of money to keep them switched in the rear of trains at all times where they will be comparatively safe.

On a road with which I was connected a few years ago the question came up about putting the old wooden equipment in condition to stand the severe service of the present day, and upon investigation it was found it would cost about \$200 per car. One of the master car builders said that if the management would commence that work at once and continue it to the time when the wooden equipment would be fully equipped, in five years their repair bills would be cut in half and every cent expended in such improvements would return within that time. The recommendation was accepted and acted upon and the matter is being watched very carefully. During the severe business depression that company has only worked about 60 per cent of their force, and after about a year of such depression they only have, approximately, four per cent of their freight car equipment held for repairs.

I noticed in one paragraph of Mr. Smart's paper that he speaks of applying different types of steel draft arms to the present wooden center sills in such a manner that it reinforces the center sills, thus greatly reducing the cost of strengthening the car. That, in my opinion, is the poorest kind of policy to be pursued. You can build a good, substantial, repair steel underframe for about \$150. The steel draft arms will cost about \$60; the salvage on the steel underframe when you get through with it is worth \$50. The steel draft arms at the best are only a poor makeshift and do not in any way serve the purpose intended, while the properly designed repair steel underframe is good as long as you want to run the car with practically no further repairs necessary. I may say the same thing about the channel makeshift.

I believe the thirty, forty and fifty thousand pounds capacity cars should be done away with at once. The cars of higher capacity with wooden underframes that it is desired to maintain should have a good, substantial underframe under them so that they will stand the shocks.

R. W. Burnett, Gen'l M. C. B., Can. Pac.: Mr. Smart's paper comes at an opportune time, as the Master Car Builders' Association have just passed a rule that after October 1, 1916, all cars of less than 60,000 lb. capacity with draft arms which do not extend beyond the body bolster will not be accepted in interchange, and as it is only a question of time until this will be extended to



cars of higher capacity, it would be unfortunate if some of the roads should equip their cars with metal draft arms not extending a sufficient distance behind the bolster, and later a rule be passed for these heavier cars that the metal draft arms should extend some specified distance a few inches beyond the arms with which a large number of cars had already been equipped. I mention this particularly as there are designs of arms extending only to the rear edge of the bolster which could easily be extended a sufficient distance.

Referring to Mr. Thompson's criticisms on reinforcements, which he considers too light, it has been my good fortune to have had considerable to do with the designing and use of steel center sills, metal draft arms and end reinforcements. Our method of underframe reinforcements has been largely at variance with that of nearly every road in the country. We have a six-inch Z-bar center sill which many consider too light, but our experience with this arrangement has been entirely satisfactory. In designing the reinforcements we have utilized the resiliency of the old car, working in harmony with the metal reinforcement that we apply. Of 14,000 old and new cars equipped with these sills during the last few years, a carefully kept record shows that repairs had been made to the sills of 74 of these cars, and these were largely on the first cars equipped, on which the sills were not so securely attached to the end sills as is now the case, and that the damage was largely due to rough handling. There has also been only one case where a foreign road has rendered bill for repairs to these sills on account of owner's defect. In nearly all of the 74 cases referred to, the sills were simply jacked back in place and more securely attached to the end sill and continued in service.

In the reasons given by Mr. Smart for failed sills and draft attachments, I believe he has omitted one of the most important, if not the most important, cause. I refer to the congestion due to heavy business on a single track road with consequent sawing by of trains. I believe this does more damage to draft attachments than yard service.

T. J. O'Donnell, Arbitrator, Niagara Frontier Car Inspection Association, Buffalo: There is no question that the points brought out by Mr. Burnett are worthy of serious consideration, but I really feel, with all due respect, that Mr. Thompson has the keynote to the situation and the necessary money required would be a very good investment.

Damages to cars in the different switching yards must be considered under the heading of ordinary handling; the operating officers are after their yardmasters for prompt service in getting trains out of the different yards, and naturally the yardmasters are obliged to make good and the severe handling is more or less universal.

The American Railway Association has more or less adopted the rules, which are now in the M. C. B. rules, that permit the transfer of cars that are unfit for service, and the receiving line should take advantage of this rule. We are obliged to in the Niagara Frontier to the extent of about 2,000 cars each month. There is no question that if some roads do not find it consistent to apply the steel underframe, the extension of draft timbers through the bolsters and the application of proper metal bolsters will greatly improve the equipment.

W. O. Thompson: When our arbitrator states that we transfer 2,000 cars a month in the Niagara Frontier it causes me to wonder how many cars are being transferred in the United States each month on account of the old wooden underframe cars. If there are 2,000 cars transferred in the Frontier, at a minimum cost of \$6 per car, it would mean \$12,000. There are probably 100,000 cars transferred in the United States every month under similar conditions, on account of defects. It seems to me that the cost of this work, at \$6 per car, would soon put steel underframes under all the cars that are to be maintained in the United States.

L. C. Ord, Asst. M. C. B., Can. Pac., chairman: Mr. Thompson's remarks about putting heavier underframes on cars have

two viewpoints. There is a difference between half a loaf and no bread. Mr. Burnett brought out the other side of the question. The Master Car Builders' Association felt that the wooden cars would stay in service if they got rid of the short wooden draft timbers, as the car with the short draft timber fails rapidly in hard service and is liable to block the track. The long draft arm running behind the bolster may fail, but you can catch it in time before serious failure takes place.

An important item is the view taken by operating officers of damage, particularly to draft gear. I was called into the office some time ago and the officer told me that though we had done quite a lot of draft gear work, if we did not follow up rough switching we would again lose ground. It is not altogether a question of getting something strong enough, as yardmen will always work up to the limit of damage. It is much more a matter that when damage occurs it should be followed up sharply to prevent a recurrence. Merely making the repairs is not sufficient in cases where unfair service caused the damage.

In regard to the short draft gear question, we have a lot of short draft gear cars and will have them for a long time to come. There are cars on which if we attempted to fit them with heavy underframes, the work could not be done quickly enough, and further, we would not get the value out of it because we could not wear the gear out by the time the car would be retired from service.

As soon as the operating officers recognize that it is necessary to protect themselves and their expenses we will get better results, but the trouble has been that the case has not been clearly or strongly enough put.

W. R. McMunn, General Car Inspector, N. Y. C.: On the line with which I am connected we are experiencing a great deal of trouble with failures of cars having short draft timbers and, regardless of the fact that we have instructions in force whereby such cars must not be operated ahead of 15 cars from caboose, this does not wholly relieve the situation. I imagine that on roads where there are no such restrictions the number of failures would be measurably greater.

Rule No. 3 of the current M. C. B. Code provides that "After October 1, 1916, all cars of less than 60,000 lb. capacity, having wooden or metal draft arms which do not extend beyond the body bolster, will not be accepted in interchange." This is the first definite step taken by the association to exclude this class of undesirable equipment from interchange. In my opinion it will be only a few years till no car will be offered in interchange unless of all steel or steel underframe construction. This will, to a certain extent, work itself out automatically by reason of the car owner being made responsible from year to year for a greater number of defects on his car by the abolition of the combinations in rules 40 to 42, inclusive. When this is done, and I am confident it will be within a few years, roads having this weakly constructed equipment will see the wisdom of properly strengthening it or keeping it in service on their own rails.

The New York Central seems to have anticipated this condition to a greater extent than many other roads, for we have applied steel underframes to about 14,000 of our older cars of all classes within the past few years, and by some we are considered pioneers in the work. It is surprising, too, to see how well these cars are standing up in service. Bills for repairs are reduced to a minimum, there is no necessity for switching cars to the rear of trains, which is expensive, and we have the cars in service at all times instead of their being held on cripple tracks half the time awaiting or undergoing heavy repairs.

Of course, there are many of the lighter capacity cars not worth spending a great deal of money on, but by process of elimination these are rapidly reduced and with M. C. B. Rule 120 to help us out, we should in the near future be able to realize our ambitions of having cars offered to us that we need not be skeptical about running and which will, under ordinary conditions, take a load to its destination without the necessity of being cut out for repairs at practically every inspection point en route.

# SHOP PRACTICE

## REPAIR WORK AT SMALL ENGINE HOUSES\*

BY G. H. ROBERTS

General Foreman, Lehigh Valley, Cortland, N. Y.

The primary object of an engine house is to care for locomotives while they are in service and keep them in service as constantly as possible by doing the "stitch in time" jobs before they develop into large ones. Inspection is a most important item about a locomotive and of course the work which is reported should be done else the inspection will be worthless. Cracked spring rigging, rods or brake rigging, nuts loose or missing, are items which, if not corrected, develop into large jobs by leaps and bounds. No matter what the facilities are, if the small jobs are not detected and remedied the power will quickly go to pieces.

Recently the writer was discussing the mileage made by a certain locomotive with an inspector who is not connected with the railroad, and who made this remark: "Why wouldn't the engine make that mileage? It was looked over every trip and every little thing was done that possibly could be." If this engine made a phenomenal mileage by having every little job done as soon as it developed, why can not each engine receive practically such attention? Of course, in some sections the conditions, such as a hilly road full of curves, are against high mileage, but even there with flange oilers the tires can be run a great deal longer than without them, and the mileage made by tires and flues usually determines the shopping limit.

The following rules if lived up to will go far toward keeping engines in service: Keep the guides lined as close as possible, the wedges set up and the rods in good order; keep the engines up on their springs; watch for low pilots before they catch on a crossing plank and are torn off, causing great damage; keep the flues cleaned, the grates in first-class condition and in superheater locomotives keep the superheater tubes cleaned out or the superheater will not perform its work economically. Most of the trouble from piston rod packing blowing can be traced directly to play in the guides or to small pistons.

Water as hot as it is possible to use it should be used for washing out; this will help to prevent the breaking of staybolts and the cracking of sheets. At washout time all boxes should be thoroughly inspected and packed, as frequently washout water will destroy the packing. Keep all the slack possible out of the driver brake hangers as it increases rapidly if not checked, and results in damage by permitting other parts to tear loose. The brake rigging gets more use and abuse than any other part and therefore requires close inspection and thorough repairs.

The smaller engine houses have not the facilities that the larger ones have, but the work can be accomplished easier and cheaper by making a plain rough sketch of such parts as spring hangers, shoes, wedges, etc., and obtaining them from a large shop, ready to apply. Where the facilities are at hand for producing them cheaply, a small quantity of such parts, if standard, can be carried in stock for immediate use. This applies to the older classes of power, fast dying out, and not so much to later locomotives that have a great many parts interchangeable.

Frequently simple devices can be applied to a locomotive and save considerable time and labor in accomplishing the same results as the longer way would. For instance, with the single rail front frames trouble is found in keeping them from working on the cylinders, as the bolts do not seem sufficient to hold them in place. By applying a clamp across the top of the cylinder directly over the rail of the frame, using a piece of small section

rail of about 56 lb., and vertical rods at the front and back of the cylinders placed as close as possible, the trouble can be overcome. The writer has tried this many times and always successfully. The clamp takes about two hours to apply, while to remove the pilot, run the truck out and rebolt the frame would require about two days, and the clamp answers the purpose even better than the bolt alone. This clamp acts similarly to a double rail front frame.

With the laws becoming more rigid every year the care and inspection of the locomotive boiler is the greatest item in round-house work. Every trip the boiler must be inspected for leaks and repaired, and all broken staybolts renewed. For years it has been the universal practice to plug the broken staybolts when only two or three existed and they were scattered, but now tell-tale holes must be kept open at all times. By having strict inspection, and keeping plenty of the various sizes and lengths of staybolts on hand at all times, this work is greatly facilitated. Defective welds in tubes that have withstood a test and a few months service can be easily detected by applying about 25 lb. pressure to the boiler and placing a light at the opposite end of the tubes from the inspector. If done at every washout this will eliminate burst tubes in service.

Because of inspections and laws becoming more rigid, engine houses need better machine and tool equipment. A ten-stall engine house, handling 30 to 40 engines a day should have the following equipment:

1 36 in. engine lathe	1 radial drill
1 24 in. engine lathe	1 36 in. by 36 in. planer
1 16 in. engine lathe	2 emery wheel stands
1 sensitive drill	

Also a drop pit for engine and tender truck wheels, a portable crane for steam chest work, a hot water system for boiler washing, a motor-equipped turntable, two air motors with capacity for 1¼ in. drills, a breast air motor for tell-tale holes and an air compressor. A hot air system of heating avoids steam leaks in severe weather; steam pipes in the pits also cause steam in the engine house because of drippings from the engines falling on them.

A good tool room with pockets for each tool is desirable as the tools in engine houses are often needed quickly and should be in a place where they can be readily obtained. A good tool room aids in keeping the place tidy as when tools and stock are kept in their places anything left lying around must be scrap, which the laborers keep picked up. Time spent hunting for tools is a loss and does a great deal to hold the work back.

Motor drive can accomplish a great saving in an engine house. In one instance a 7½ h. p. motor was installed to replace a stationary engine and it has saved about 75 tons of coal per month. The engine had to be run practically continuously as it was not easily started and stopped, while the motor can be stopped and started very easily and is run only when needed. A separate motor-driven fan was installed for the blacksmith forge, making it independent of the line shafting. The steam engine was isolated and the exhaust could not be turned into the stack for draft. However, after installing the motor the exhaust from the air and water pumps adjacent to the boiler was turned into the stack and practically did away with the use of the blower to keep up steam. This saves considerable coal as the blower was used almost continuously. Formerly two boilers were run in the winter months but since the motor was installed and the exhausts used, one boiler has furnished an ample supply of steam during the most severe weather. In addition the one boiler supplies steam to the ash track for cleaning the ash pans; the two boilers did not have this additional duty.

A steam line was laid to the ash track for use in thawing out

\*Entered in the competition on Engine House Work, which closed July 15, 1914.



hopper ash pans in winter. Formerly an engine equipped with steam heat was used and the inconvenience has been greatly reduced by the steam line. The handling of engines in the ash track is a hard task in severe weather. During very severe weather we run engines directly into the engine house from the road and thaw them out before hostling them, saving considerable time on the ash pit. Much trouble with the turntable was caused by ice forming around the center pin and freezing it solid. By applying a steam coil around the center this was avoided. The steam used is taken from the sand dryer, making it serve a double purpose.

A great saving in time can be made by watching the work reports as the locomotives arrive. For instance, if an engine has given trouble with grates of the longitudinal type, by not coaling the engine before it is placed in the engine house the grates and bars can be removed, repaired and replaced without cutting the engine and tender apart, which takes considerable time. This one item will save at least one hour on the repairing of the grates. Frequently a tank will need repairs and if it is noted in time and the tender is not coaled, it saves unloading it, which takes about two hours. The same consideration applies to sand; when the sand box is to be repaired the hostler should be notified not to sand the engine.

Close inspection at all times and the use of all possible short cuts will go far toward keeping up the power. The personal element enters the work more than the equipment available; an engine can receive just as good an inspection at a small engine house as in the most up to date shop. Inspection is the most important item in engine house work.

### PATCHING BOILERS ACCORDING TO LAW

BY GEORGE G. LYNCH

Because of the use of the patch bolt and the outside plate for so many years in hurry up jobs of locomotive boiler repairing, with the size and spacing of rivets left to the discretion of the average repair shop foreman, it is hard to bring about a proper appreciation of the necessity for calculation of the tension in the plate and the shearing stress upon the rivet or patch bolt to insure a condition of perfect safety. But since the federal boiler inspection law has been in force, the necessity arises for the actual calculation of stresses in designing boiler patches, so that they will have a theoretical factor of safety of not less than four. It is the purpose of this article to present the facts in such a way that the average shop man will be in a position to recognize the importance of the calculations, and to carry out the work so that the boiler will actually have the strength that is theoretically claimed for it.

For boilers made of plate and rivets of unknown strength the law allows the following ultimate stresses: tension in steel plate, 50,000 lb. per sq. in.; tension in iron plate, 45,000 lb. per sq. in.; shearing stress in steel rivets, 44,000 lb. per sq. in., and shearing stress in iron rivets, 38,000 lb. per sq. in. These figures divided by four, or the factor of safety, give the actual maximum stress that may be created in the plate or rivet by the steam pressure within the boiler.

The resultant force of the steam pressure which produces a tearing effect upon the plate and a shear upon the rivets will best be understood by reference to Fig. 1, which shows the steam pressure acting in opposite directions tending to burst the shell. Let the steam pressure in pounds per square inch =  $P$ , the inside diameter of shell =  $D$ , the inside radius of shell =  $R$ , and let  $p$  = a unit length of the boiler shell. Then  $P \times D \times p$  = the stress upon both sides for a unit length, or  $P \times R \times p$  = the stress upon one side for a unit length. This shows the tendency of the shell or joint to pull apart when the boiler is under steam pressure.

Now suppose a hole be drilled at each end of the longitudinal distance  $p$ , as in Fig. 2. We can readily see that the force upon

the length  $p$  will be the same while the plate is reduced an amount equal to the diameter of one rivet hole. Then if we let  $t$  = the thickness of the plate, we have an area equal to  $t \times (p - d)$ , which is known as the net section of the plate. This is the condition always found along the line of the outside row of rivets in the longitudinal seams. If the dimensions are given in inches and the pressure  $P$  is given in lb. per sq. in., we can readily calculate the tension upon the net section of the plate between any two rivet holes. According to the law this tension must not exceed  $50,000 \div 4$ , or 12,500 lb. per sq. in., for steel

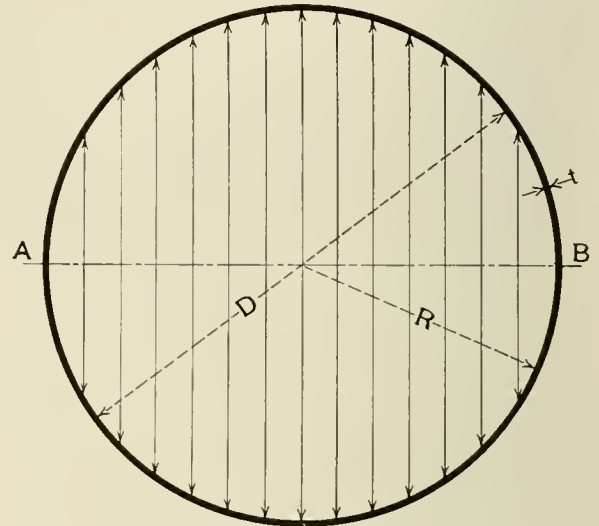

Fig. 1—Action of Steam Pressure, Tending to Burst the Shell

plate of unknown strength, and  $45,000 \div 4$ , or 11,250 lb. per sq. in., for iron plate of unknown strength.

As an example let us assume that we have a boiler with the following dimensions:  $P = 175$  lb.;  $D = 60$  in.;  $R = 30$  in.;  $t = 0.5$  in.;  $p$  (pitch of outside row of rivets in seam or patch) = 3 in.; and  $d$  (diameter of rivet holes) =  $13/16$  in. (0.8125 in.). The stress acting for distance  $p$  will be equal to  $175 \times 30 \times 3 = 15,750$  lb. The net section of plate will be equal to  $(p - d) \times t = (3 - 0.8125) \times 0.5 = 1.093$  sq. in. Dividing the net section in square inches into the stress, we have the tension per square inch, thus:  $15,750 \div 1.093 = 14,409$  lb. per sq.

$d$  = Diam. of Rivet Hole  
 $p$  = Pitch of Rivets  
 $t$  = Thickness of Plate  
 $(p - d) \times t$  = Net Section of Plate

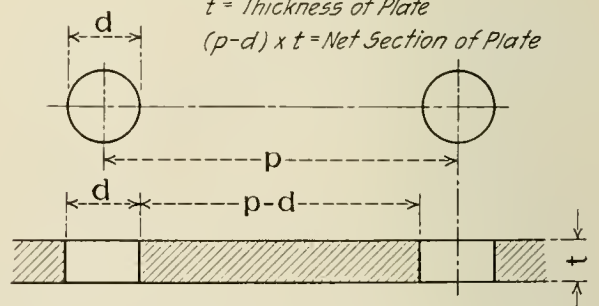

Fig. 2—Different Conditions After Drilling Holes

in., which is too high, giving a factor of safety of  $50,000 \div 14,409 = 3.5$ , instead of 4 as required by law.

Assuming that this is a seam with an ordinary double riveted lap joint, with 3 in. pitch. or an outside patch with a double row of rivets along the longitudinal edges, in order to attempt to maintain the steam pressure at 175 lb., we would have to apply an inside cover plate and add an outer row of rivets with 6 in. pitch. Then the tension along the row with 3 in. pitch would be lessened by the shearing value of the outside rivets. In this case we would have  $P \times R \times p = 175 \times 30 \times 6 =$

31,500 lb., as the total stress in the net section between the rivets of the outer row; and  $(p - d) \times t = (6 - .8125) \times 0.5 = 2.59$  sq. in., as the net section. Stress divided by net section =  $31,500 \div 2.59 = 12,162$  lb. per sq. in., which appears to be

sume that the rivets are of steel the shearing stress must not exceed  $44,000 \div 4$ , or 11,000 lb. per sq. in. The total resistance, then, will be  $(p - 2d) \times t \times 12,500 + 0.5185 \times 11,000 = 27,350 + 5,704$ , or 33,054 lb. The total stress will be  $175 \times 30 \times 6$ , or 31,500 lb. In this calculation we find the number of square inches in two net sections of one of the inside rows, and the area of half of two rivet holes in the outside row, multiply the first by its allowed tensile strength per sq. in., and the second by its allowed shearing value per sq. in., add the two values and we have the combined resistance, which must be equal to or greater than the stress acting over the distance  $p$ , the pitch in the outside row.

Thus far the joint will be safe after adding the inside welt strip or cover plate, but we have yet to consider the failure by shearing all rivets on one side. In the first case we had a double riveted lap seam with 3 in. pitch,  $3/4$  in. rivets and  $13/16$  in. holes. The shear on the rivets would be equal to the stress in the net section divided by the area of two rivet holes, or  $175 \times 30 \div 2 \times 0.5185 \times 2 = 15,188$  lb. per sq. in. But the law allows only 11,000 lb. per sq. in. for steel rivets in shear and 9,500 lb. per sq. in. for iron rivets. With steel rivets we have a factor of safety of  $44,000 \div 15,188$ , or only 2.9 instead of 4.

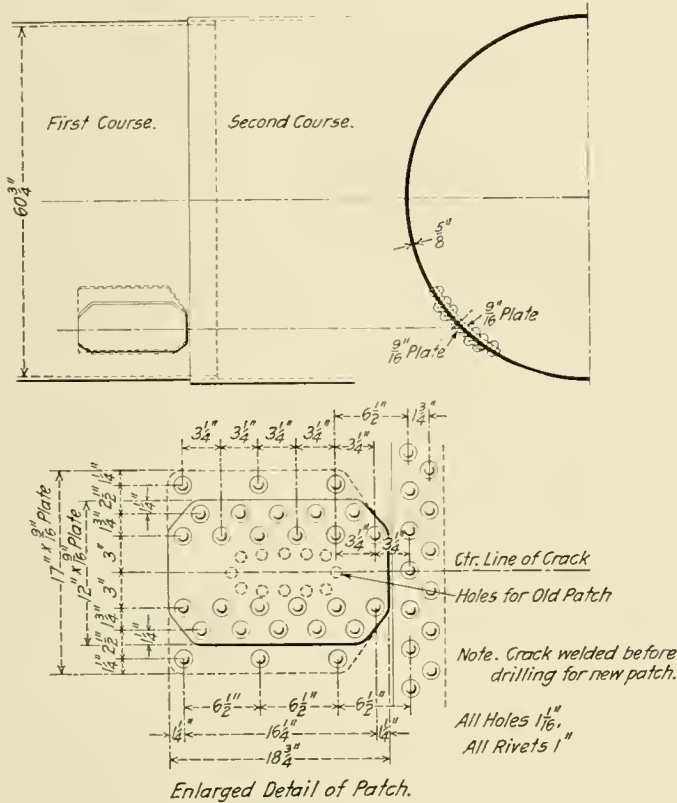

Fig. 3—Replacing an Unsatisfactory Patch

ideal for the tension at the outside row, but the combined tension at the inside row and the shear upon the rivets in the outside row may be too high. In this case the net section is

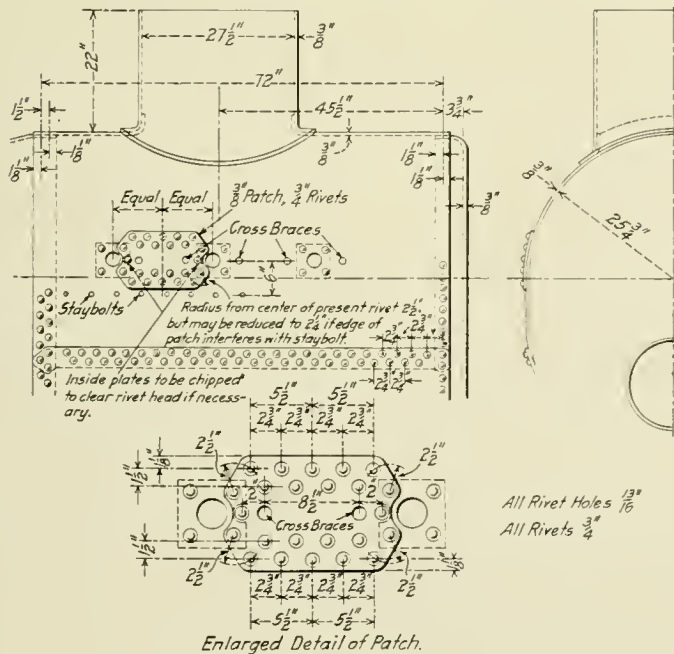

Fig. 4—Difficult Patch Placed Between Two Washout Holes

$(p - 2d) \times t$ , as there are two spaces in the inside row for each distance  $p$ , in the outside row; and the area of the rivet holes, which are  $13/16$  in. in diameter, is 0.5185 sq. in. If we as-

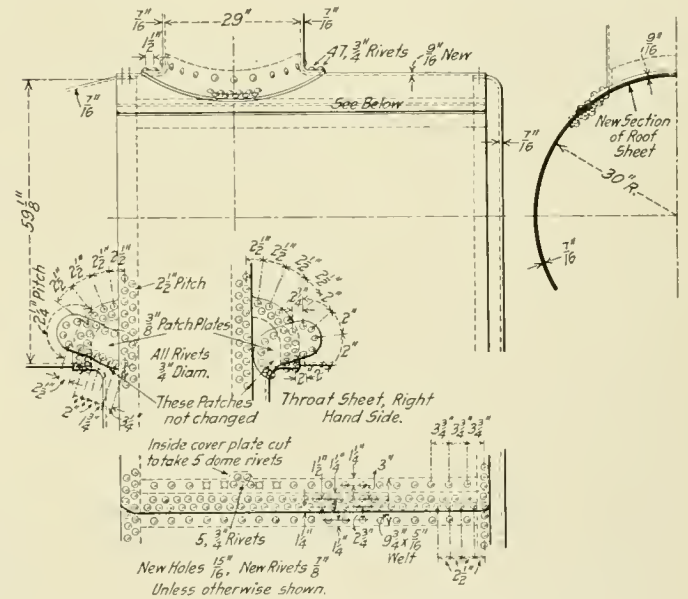

Fig. 5—Application of New Roof Sheet

Therefore, even if the tension upon the net section of the plate had been within the required limit, the shear upon the rivets would have been too high. But the addition of the welt strip gives one more rivet in shear, so we have  $175 \times 30 \times 3 \div .5185 \times 3 = 10,125$  lb. per sq. in., which gives a factor of safety of 4.3.

In case the shear upon the rivets were still too high we might increase the size to  $7/8$  in., but in this case the tension upon the net section would have to be re-calculated, as the holes would be larger and the net section less. Another method would be to leave the rivets at  $3/4$  in. and widen the welt strip so that another row of outside rivets could be added, but this would be rather unusual and it would be better to reduce the pressure to suit the conditions.

The tension on the net section of plate is responsible for the inside cover plate in nearly every case, because the seams have to be calked on the outside and if the rivets are close enough together to make a good calking edge it will nearly always be found that the tension upon the plate is too high. In boilers of high pressure, with double or triple riveted butt seams, the inside cover plates also increase the shearing value of the rivets by causing the inner rows to be in double shear, for which the law allows double the value of single shear.



In applying inside cover plates the thickness has to be considered in order that the bearing value of the plate will be equal to or greater than the shearing value of the rivets, or in other words the inside plate must be strong enough to shear the outside row of rivets in case the shell plate should tear along some inner row. By reference to steel hand books we find that a 5/16 in. plate is thick enough for 3/4 in. rivets, a 3/8 in. plate for 7/8 in. rivets, a 7/16 in. plate for 1 in. rivets, and a 1/2 in. plate for 1 1/8 in. rivets. The outside cover plate should be of the same thickness as the shell plate for all outside patches, and for all patches or butt seams with inside plates which are less than triple riveted. In triple riveted seams the outside plate is sometimes slightly less than the shell plate, as the bearing area is doubled.

There are other ways in which a joint or patch may fail, such as crushing the plate in front of the rivets or crushing the rivets, but if the cover plates and rivets are of good material and of the proper thickness and diameter, there is usually a higher factor of safety than is required. In the double riveted lap seam first considered we had a total stress in the net section of 15,750 lb. Assuming the crushing value of the plate to be 88,000 lb. per sq. in., the maximum allowable working stress is 22,000 lb. per sq. in. The number of rivets in each distance  $p$  is 2 (designated by  $n$ ). The total resistance to crushing will therefore be  $d \times t \times n \times$  allowable crushing stress in the plate, or  $0.8125 \times 0.5 \times 2 \times 22,000 = 17,875$  lb. Thus we see that the stress is 15,750 lb., while the resistance is 17,875 lb., or 2,125 lb. more than necessary for a factor of safety of 4. The resistance of the rivets to crushing may be obtained in the same manner by substituting the allowable crushing stress of the material in the rivets for the crushing stress of the plate just used.

In any boiler the stress per unit section exerted longitudinally is only half that exerted transversely, and in most cases it is safe to duplicate the circumferential seams for the ends of a patch.

Several patches and replacements, which have been applied to locomotive boilers to comply with the boiler inspection law, are shown in Figs. 3 to 5 inclusive. In each case these have been calculated to provide a minimum factor of safety of 4. Figure 3 shows a patch replacing an old one which had only an outside plate with holes very close together. This arrangement caused high tension on the net section of the plate and too great a shearing stress upon the rivets or patch bolts, and gave a low factor of safety. Figure 4 shows a difficult patch applied on the outside between two washout plug holes, to cover radial cracks around the cross brace holes. This patch being above the stayed surface had to be calculated by the radius of the roof sheet, as if it were in the shell of the boiler.

Figure 5 shows the application of a new section of roof sheet with welt strips, which were found necessary on account of the large radius, and because the seams are above the stayed surface. The two throat patches were calculated and found safe as originally applied.

## FIRING UP ENGINES AT ENGINE HOUSES\*

The methods outlined in the following brief description, for firing up locomotives, have given very good success in the elimination of smoke and may be readily used by nearly all roads.

When wood is used for the kindling, both sides of the firebox, the back corners and under the fire door, are filled with a layer of coal about 12 in. or 16 in. in depth, allowing the fuel to slope down toward the center of the firebox, covering it to a depth of 3 in. to 6 in. About one-eighth of a cord of wood should then be placed on the coal and the fire started by means of oily waste. The coal will then ignite very slowly, becoming coked

as it burns down, and by using a forced draft the stack of the engine or the enginehouse jack will be kept clear of smoke. It has been found that a draft of 3 1/2 in. of water is sufficient to start the fire and produce no more than No. 1 smoke. This method requires about two hours to obtain boiler pressure from a cold engine, but it may be hurried by increasing the draft and scattering coal occasionally over the bright spots in the firebox, and still give a very good smoke performance. This method is also of advantage on account of the heavy fuel bed thus formed; it is usually unnecessary to add much fuel until the engine leaves the engine house. No special grade of wood is required.

Tests have been made with various kinds of woods to determine their efficiency in kindling the fires at engine houses. Each test was hurried and it was found that the wood had very little bearing on the smoke density. Listings, bark, car wood, large wood and split ties were used in an Atlantic type locomotive, not equipped with steam jets, for each of the tests. Following is a brief description of the tests:

*Test No. 1.*—In this test the engine had 40 lb. of steam on when the fire was started. One-seventh of a cord of car wood was used for kindling the fire, together with 85 scoops of coal. It required 33 minutes to obtain boiler pressure. The smoke readings at the smokejack showed 14 min. of No. 1 smoke, 12 min. of No. 2 smoke, 2 min. of No. 3 smoke and for 5 min. a clear stack.

*Test No. 2.*—This test was started with a boiler pressure of 50 lb., and four bundles of listings were used for the kindling wood, with 50 scoops of coal. Boiler pressure was obtained in 35 min. and the smoke jack readings showed 14 min. of No. 1 smoke, 10 min. of No. 2 smoke, 3 min. of No. 3 smoke and 8 min. with a clear stack.

*Test No. 3.*—This test was started with 50 lb. of steam on the boiler and one-eighth of a cord of split ties was used as kindling wood, together with 90 shovels of coal. The required boiler pressure was reached in 60 min. The smoke stack readings showed 15 min. No. 1 smoke, 27 min. No. 2 smoke, 2 min. No. 3 smoke, and 16 min. clear stack.

*Test No. 4.*—This test was started with 65 lb. pressure in the boiler and the fire was lighted with one-eighth of a cord of bark used as kindling wood; 79 scoops of coal were used. The boiler pressure was reached in 25 min., and the smoke jack readings showed 10 min. of No. 1 smoke, 7 min. of No. 2 smoke, 2 min. of No. 3 smoke and 6 min. a clear stack.

*Test No. 5.*—This test was started with 65 lb. of steam on the boiler and one-fifth of a cord of large wood, consisting of car sills, beams, etc., was used for kindling, with 85 scoops of coal. The boiler pressure was reached in 25 min. and the smoke jack readings showed 16 min. of No. 1 smoke, 4 min. of No. 2 smoke and 5 min. clear stack.

As shown by these tests, the kind of kindling wood did not make any particular difference in the amount of smoke produced and the smoke obtained is attributed to the rushing of the firing up process. The most efficient kindling used was the car wood. Possibly the only advantage of certain kinds of kindling is that they may ignite quicker and the engine may thus be made ready for service in a shorter time.

To fire up an engine with crude oil the coal should be placed on the grate in the manner described above. When there is no hurry in getting up steam the crude oil torch should be operated through the fire door and focused on the part of the coal next to the tube sheet, kindling and igniting the fuel from that point back to the fire door. The torch should be held about 30 in. from the fuel, as otherwise the oil will be sprayed on the fuel, causing black smoke to be emitted from the stack. This process usually requires from 4 to 6 gal. of oil to each firebox and about 15 min. are taken to kindle a fire properly, depending, of course, upon the size of the firebox. In all methods of firing up proper supervision must be given in order to reduce the smoke to a minimum.

\*From a paper presented at the ninth annual convention of the International Association for the Prevention of Smoke.

### BOILER SHOP METHODS

The American Locomotive Company has developed a number of standard methods of handling the work in its boiler shops, and has had drawings and data arranged as shown in the accompanying engraving for the purpose of instructing employees

in the proper methods of performing this work. These methods should prove of value to boiler shop foremen and the drawings and allied instructions will be found self-explanatory. Some of the practices outlined, particularly those connected with the lifting of various parts, will be of special interest to anyone who is following the "Safety First" movement.

<p>1 REMOVING PLATES FROM CAR. SPECIAL CLAMP MUST BE USED.</p>	<p>2 LIFTING PLATES ON PLATE DRILL. SPECIAL HOOK.</p>	<p>3 HANDLING SHEETS AT PUNCHES, SHEARS, PLATE PLANER, LAYOUT AND DRAGS. TWO CLAMPS BY EACH END.</p>	<p>4 Mc CARTHY CLAMP AT PUNCH &amp; SHEARS</p>	<p>5 CARRYING WELT STRIPS. ENDLESS CHAIN 10' LONG</p>	<p>6 SCARFING AT HAMMER. SPECIAL CLAMP.</p>
<p>7 PLACING ON ROLLS. AT ROLLS</p>	<p>8 REMOVING FROM ROLLS. AT ROLLS CROWN AND TOP SHEETS</p>	<p>9 ROTARY SHEARS.</p>	<p>10 WELDING. PUTTING A SHELL IN PIT</p>	<p>11 AT SHELL DRILL</p>	<p>12 THESE INSTRUCTIONS ARE FOR GUIDANCE OF EMPLOYEES IN THE BOILER SHOP. CAREFUL OBSERVANCE MUST BE GIVEN THEM BY ALL SUCH EMPLOYEES. IF IN CASE THERE IS MATERIAL HANDLED IN THIS DEPARTMENT CONTRARY TO THESE INSTRUCTIONS ALSO GIVE PARTICULAR OBSERVANCE TO SUCH CLAMPS, HOOKS, CHAINS, ETC., AS THEY MAY BE PROVIDED AND UNDER NO CIRCUMSTANCES PUT THEM OUT OF SERVICE IMMEDIATELY AND REPORT TO FOREMAN. CRANEMEN MUST NOT MOVE THE MATERIAL ON WHICH THE LOAD IS NOT PROPERLY MADE. IF MAN ON THE FLOOR DOES NOT CHANGE REPORT TO FOREMAN BEFORE MOVING THE LOAD.</p>
<p>13 LIFTING &amp; HOLDING A BOILER ON BULL RIVETER.</p>	<p>14 LIFTING A BOILER TO BULL RIVETER.</p>	<p>15 HANDLING A DOME ON BULL RIVETER.</p>	<p>16 HANDLING A DOME ON DRILL. ALSO HANDLING A TIGHT SHEET ON DRILL.</p>	<p>17 TOP AND CROWN SHEETS</p>	<p>18 HITCH ON A FIRE BOX.</p>
<p>19 RAM FOR LINING UP FRONT SHEETS.</p>	<p>20 HOLDING THROAT SHEET WHILE LINING UP.</p>	<p>21 PLATFORM IN FIRE BOX.</p>	<p>22 HORSES &amp; SCAFFOLD PLANK.</p>	<p>23 START TURNING A BOILER. FINISH TURNING A BOILER.</p>	<p>24 CARRYING A BOILER.</p>
<p>25 LIFTING A 2 FIREHOLE BOILER.</p>	<p>26 HANDLING A BOILER. NOT TO EXCEED 30 TONS.</p>	<p>27 TOP SHEET ON HORSES.</p>	<p>28 THE RIGHT WAY THE WRONG WAY How to place BLOCKS UNDER MATERIAL.</p>		
<p>29 CARRYING MUD RING &amp; SUTTING RING INTO PIT.</p>	<p>30 CARRYING RING THROUGH SHOP.</p>	<p>31 HANDLING DIES.</p>	<p>32 THROAT SHEET HITCH.</p>	<p>33 HANDLING SHEET AT FLANGING FURNACE.</p>	<p>34 AT HORIZONTAL PUNCH.</p>
<p>35 BACK &amp; FRONT FLUE SHEET.</p>	<p>36 AT FLANGING FURNACE. BACKHEAD &amp; FLUE SHEETS.</p>	<p>37 FOR DOME PLATES AT FLANGING PRESS.</p>	<p>38 HANDLING SMOKE BOX FRONT AND RINGS.</p>	<p>39 CARRYING TUBES.</p>	<p>40 PLACING A DOME ON BOILER.</p>

Chart Showing Various Practices In American Locomotive Company's Boiler Shops





making the pegs square, the full strength of the stock is retained, whereas in the round pegs used in slab cutters over one-half of the stock is milled from the face to secure the cutting

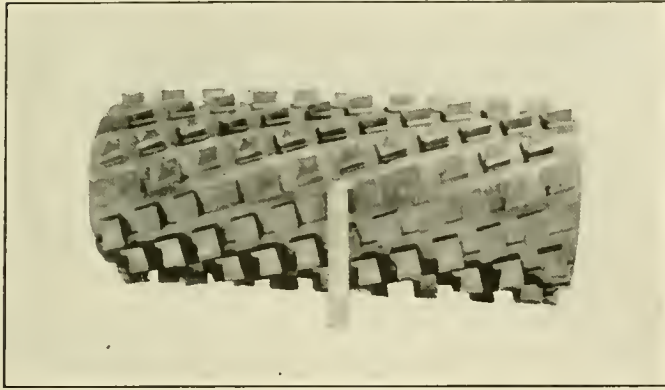

Fig. 3—Slabbing Mill Which Has Given Good Results

face. The shoulder milled for the seating of the pegs eliminates any possibility of their turning.

### FORGING MACHINE DIES

A number of forging machine dies were described by J. W. McDonald, foreman blacksmith of the Pennsylvania Railroad, at Trenton, N. J., at the annual convention of the International Railroad Master Blacksmiths' Association convention, held in Milwaukee last August. Fig. 1 shows dies for making ash pan levers. This lever is made from  $\frac{5}{8}$  in. by 3 in. bar iron, on the

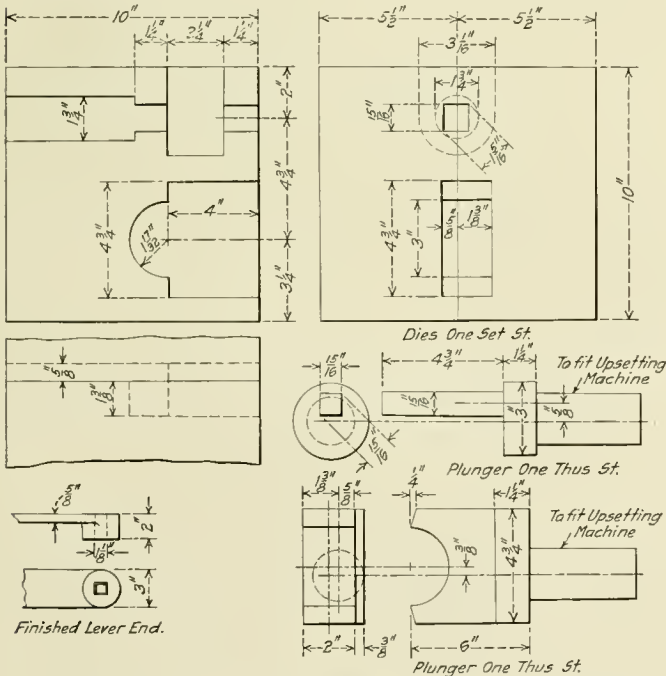

Fig. 1—Dies for Forming the Boss End of Ash Pan Levers

end of which is welded a piece of iron  $1\frac{1}{4}$  in. by 3 in. by  $3\frac{3}{4}$  in. with all four corners sheared off. The two pieces are placed together and heated to a high welding heat in an oil furnace. They are then upset and welded by one stroke of the forging machine. The  $1\frac{1}{8}$  in. tapered hole is made in the same heat. The hole is first punched  $15/16$  in. square in the same die in which it was upset and is then drifted to the required taper by a tapered pin placed on the machine instead of the shear.

This work is done on a  $2\frac{1}{2}$  in. machine, and the finished piece is shown in Fig. 2. It makes a neat job at a low cost.

Fig. 3 represents dies used for bending brake hangers on a pneumatic bending machine provided with an 18 in. cylinder and a  $30\frac{3}{4}$  in. stroke. The hanger is heated and placed on a centering block on the female die, as shown by the dotted line



Fig. 2—Ash Pan Lever Made with the Dies Shown in Fig. 1

marked "Hanger in position for bending." The head of the machine then moves forward and the hanger enters the groove in the male die. At the same instant the point of tension screw B has started up the angle of the wedge strip of spring steel.

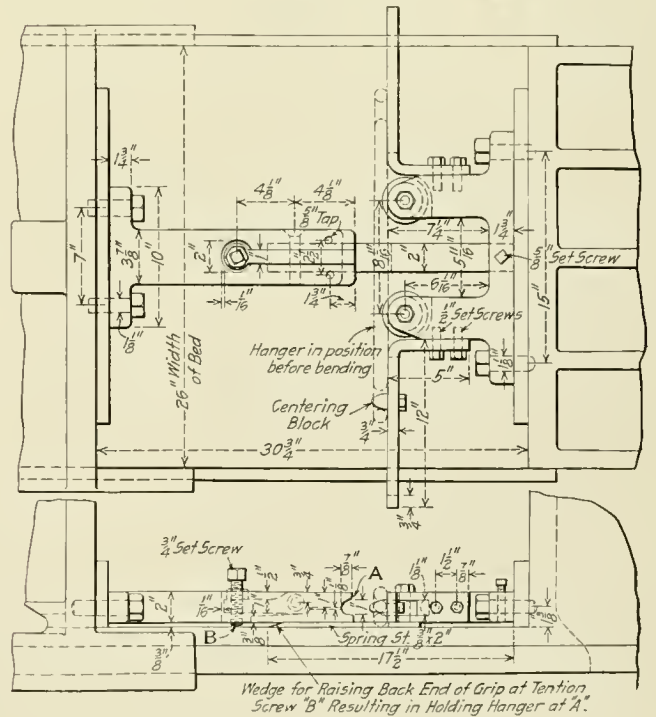
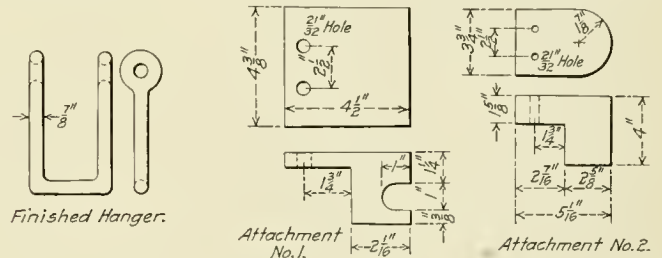

Fig. 3—Dies for Bending Brake Hangers

This causes the dog to give a vise-like grip on the hanger. The proper amount of grip necessary to hold the hanger is regulated by the tension screw B, it being raised or lowered to suit. With





## PAINTING LOCOMOTIVES AND STEEL CARS\*

BY MILTON L. SIMS†

The preparation of a steel coach for painting is of vital importance, demands the closest attention and should never be left to inexperienced help. It must be done thoroughly, as the absolute removal of all scale, grease and corrosion is necessary before any protective coatings are applied. Any idea that paint coatings will stop corrosion when it has once started, is not correct. Properly selected paint pigments, combined with the proper vehicles, will prevent the starting of corrosion.

There are several methods of removing rust from steel, such as coating the surface with oils and rubbing with steel wire brushes, emery cloth, steel scrapers, etc., but the safest and most economical for the outside of cars is the sand blast. For the interior of a steel car, I would recommend the use of raw linseed oil and benzine or gasolene, in the proportion of one part of the oil to two parts of the benzine, applied with a brush and rubbed down with emery cloth or paper.

The sheet steel used on the interior of cars is of much lighter weight and finer texture than the outside sheathing, and does not need the sand blasting. After the rubbing down is completed, the surface should be washed with gasolene and wiped dry with rags or waste, and it is then ready for the priming coat, which in all cases should be applied as soon as possible after the surface has been cleaned. This applies especially to the outside surface of the car, where the sand blasting process has been used, as corrosion will start up again in a few hours when the atmosphere is damp, and great care should be taken to prevent handling the surface with the naked hands.

We are now ready to apply the priming coat to the steel surface. This priming coat is more important than any that is to follow, except the coats of finishing varnish, and too much care cannot be exercised to see that the work is done thoroughly, brushed out evenly and every bolt head and joint coated perfectly, using suitable brushes for the purpose. This priming coat must be made from suitable pigments and carrying vehicles, finely ground and thoroughly mixed to work freely and spread smoothly under the brush, dry hard, but elastic enough to safely withstand the contraction and expansion of the steel surface, which varies greatly in different sections of the country. On the through trains running from the ice and snow of the North, to the tropical climate of the South, the change has a marked influence in producing cracking and disintegration of paint and varnish films as applied to steel cars much more than wooden cars.

When this priming coat has dried safely, the next step is to hard putty and glaze coat over all rough places, and this takes us to the second coat or brush surfacer, which is designed to fit with the priming coat. This material must also be finely ground and work and spread easily over large surfaces. It must dry hard, but elastic, and be made from selected materials. The next step is to apply a much heavier bodied surfacing material, which is then knifed off, leaving a very smooth surface, which requires very much less rubbing to bring the surface up ready to receive the color coats. The old method of using block pumice stone and water, is dispensed with, and a method employed consisting of rubbing the surface down smooth by using emery cloth, in connection with equal parts of raw linseed oil and benzine, and then washing or wiping off with rags or waste and clear benzine or gasolene. This method of surfacing does away with all danger from moisture and prevents the starting of corrosion. The oil forms a good sealer for the more or less porous surfacing material and forms a safe foundation for the succeeding color and varnish coats.

One coat of specially prepared car body color is now applied.

When this is dry, a second coat is applied, which is of an elastic enamel quality, dries hard with a semi-gloss, but makes an elastic surface suitable for striping and lettering. After this, two coats of durable outside finishing varnish are applied, and the outside of the car is ready for service.

The same priming material should be used on the interior surface and followed by the second coat of brush surfacer. The heavy coat of knifing material can be dispensed with, and after the rubbing with emery cloth, oil and benzine has been finished, there follows a suitable ground work for graining in imitation of natural woods. After this, apply two coats of elastic rubbing varnish; rub to a dead finish with rubbing oil and pulverized pumice stone, or polish if desired. Where solid colors are used on head and side linings, an option is given for the use of special enamels, or quick drying elastic headlining colors to be striped and varnished over.

Canvas roofs require a specially prepared roof primer which dries very elastic and does not penetrate clear through the cotton fabric. This prevents the rotting of fabric, which is sure to occur where too much vegetable oil is used. After the special primer has been applied, special long-life roof paints are applied.

These methods are the outcome of years of careful observation of results attained by the use of methods formerly in use. Following is a schedule for painting the exterior of a steel coach:

- 1st day. Apply priming coat.
- 2nd day. Hard putty and glaze all rough and uneven parts of surface.
- 3rd day. Apply coat of brushing surfacer.
- 4th day. Apply coat of knifing surfacer.
- 5th day. Rub out with emery cloth, using half and half raw linseed oil and herzine, instead of block pumice stone and water.
- 6th day. Apply first coat of car body color.
- 7th day. (If Sunday), drying.
- 8th day. Apply second coat of car body color enamel.
- 9th day. Stripe and letter.
- 10th day. Apply first coat durable outside finishing varnish.
- 11th day. Drying.
- 12th day. Apply second coat of durable outside finishing varnish.
- 13th day. Car is completed.

Where shop conditions of heat and ventilation are correct, several days can be cut from this schedule, by applying the first and second coats of car body color in one day and by striping and lettering and applying the first coat of varnish in one day.

### LOCOMOTIVE PAINTING

The method used in painting a locomotive, differs very slightly from that of a steel coach. The same primer and surfacing materials are used and rubbed out in the same manner, then the color coats which are usually black, are applied. For this purpose an enamel black is used on which the lettering is done and one coat of durable locomotive finishing varnish is usually applied on the water tank or tender, cab, steam dome and sand box, steam chest and cylinder casings, etc., for the best work. The enamel black should be made from selected materials which are known for their wearing and heat-resisting qualities. If the surfacing materials are made too rich with oils, blistering on the heated surfaces will often result.

Speed is demanded in locomotive painting, as each day that a locomotive is kept out of service, represents so many dollars of earning power for the railroad company. The machinists, boiler makers, pipe fitters, etc., usually get all the time and the painters get what is left, but it cannot be helped. The actual time necessary to turn out a satisfactory job, depends on shop conditions. Two and often three operations on the schedule can be carried out safely in one day. Assuming that care has been taken in removing all grease, scale and corrosion from the surface to be painted, the following schedule may be used for locomotive painting:

- 1st day. Apply priming coat of special locomotive primer.
- 2nd day. Hard putty and glaze coat all rough and uneven surfaces. (This does not apply to trucks, frame work, etc.)
- 3rd day. Apply brushing and knifing surfacer to water tank or tender, cab, steam dome, sand box, etc.
- 4th day. Rub out surface with emery cloth, using half and half raw linseed oil and benzine. Wipe off dry with rags or waste and clear

\*From a paper read at the meeting of the Central Railway Club, Buffalo, N. Y., November 13, 1914.

†Special representative, Sherwin-Williams Company, Cleveland, Ohio.





pairs, such as renewal of tubes, changing wheels, etc., can be made on several engines at once. This furnishes enough work to take care of the varying conditions of engine house work. Some assigning of certain work to certain men is essential, but it is possible to overdo this.

Inspection is one of the most important features. Two good engine inspectors, one working under the engine and one outside, can inspect and do many small jobs on 35 to 40 engines, with one man working 9 hours and the other 12 hours for the day force, and the same for the night, giving the service of one man throughout the 24 hours on engine inspection. There should also be two men on air brake inspection in the same way, day and night. This means working inspection; the men see all they can and do all they can and do not, with pencil and paper, search for work for some one else to do. Another important matter is to have a man trained to set engines so that he can set up the wedges and key the rods, and keep the knuckle pins and wrist pins tight. He should also put in new guide bolts and cross-head shoe bolts when they are required.

Another classified job should be the grates and front end work so as to have the rough work taken off the higher paid mechanic and at the same time have a man trained to do this work quickly and well. This job should not be made too cheap. A pipefitter should also be trained for engine house work; he should do all the steam heat and piping work, cab work, gage cocks, etc. This puts most of the piping outside of the air brake gang all in one man's hands and in this way he may have the tools and experience to handle the work with speed, while at the same time it relieves the other men of the care of piping tools.

Air brake work should be handled separately from the other machinist's work. There should be one man to do the oiling, one on the grease cups and one on the headlights and markers. Special men should be trained to blow out the tubes and take down arches, and also to prepare engines, for the boiler makers. The latter will cool down the engines when required and connect the blowers so that the engines may be put in condition for the men to work on them. The regular machinist force should be so trained that while special jobs are assigned to individual men, as they show more aptitude at certain work, they should be overlapped to cover all lines of engine house work. The idea of one man having a busy day one day and a slack one the next is poor policy; let them all have a busy day or a slack day together.

Work slips should be turned in every day and carried over from shift to shift; in case of an engine being used again with work not done they should be turned in so marked. On investigation, if this work seems important and its neglect has a bad effect on the engine, steps must be taken to have it done.

A book should be kept with the dates of washout and the cleaning of tubes and arches, and enginemen given to understand that there are certain dates when the engines are dumped; that they will not be blown off to pack throttles and grind gage cocks at such times as the engineman picks out, but that he will have to conform to this system. If enginemen are in the habit of leaving their engines at night with a small work report or none at all, and then coming around in the morning and requiring part of the engine house force to wait on them, they should be told to make out work slips on their next trip showing what is wanted.

Avoid doing duplicate work or unnecessary work just because somebody wants to be satisfied. Do not reduce front end brasses so that they turn the wrist pins in the crossheads, or close in main pin brasses so that they run hot, or set up wedges until they stick; keep the wedges parallel, brasses keyed brass and brass, guides closed and pedestals tight, and if the main wheels need to be dropped, do it when it is thought they need it, after an examination and a conference with the road foreman of engines.

Responsibility for the care of the power should reach from the lowest paid man up to the master mechanic if the system

is right and a system should be employed, no matter how poor it may seem at the start. The engine dispatcher and general foreman should co-operate in every way. A board should be kept showing all engines to be despatched and their leaving time, and another board for the use of the men in marking off the work as it is done.

The master mechanic should keep in touch with his foremen and know what is needed as to tools, etc., and he should use his influence with the higher officers to obtain them.

### PAINING STEEL CAR DOORS

At the recent Master Car and Locomotive Painters' convention at Nashville, Tenn., C. A. Cook, master painter of the Philadelphia, Baltimore & Washington, Wilmington, Del., mentioned

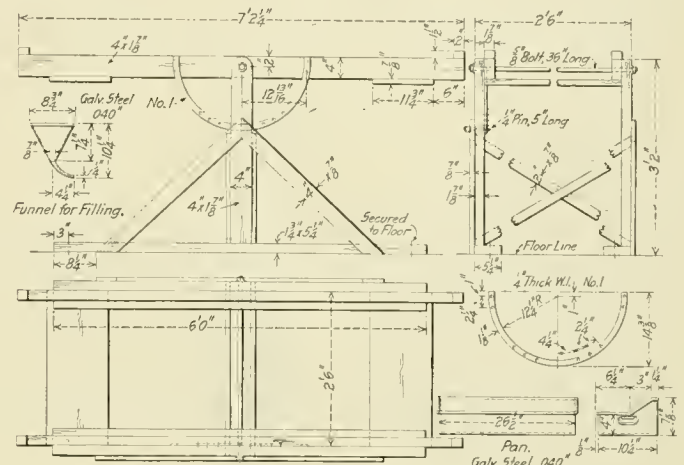

Fig. 1—Adjustable Rack for Slushing Steel Doors

two shop kinks that were especially valuable in painting steel car doors. These are shown in the accompanying illustrations. Fig. 1 illustrates an adjustable rack equipped with a pan and

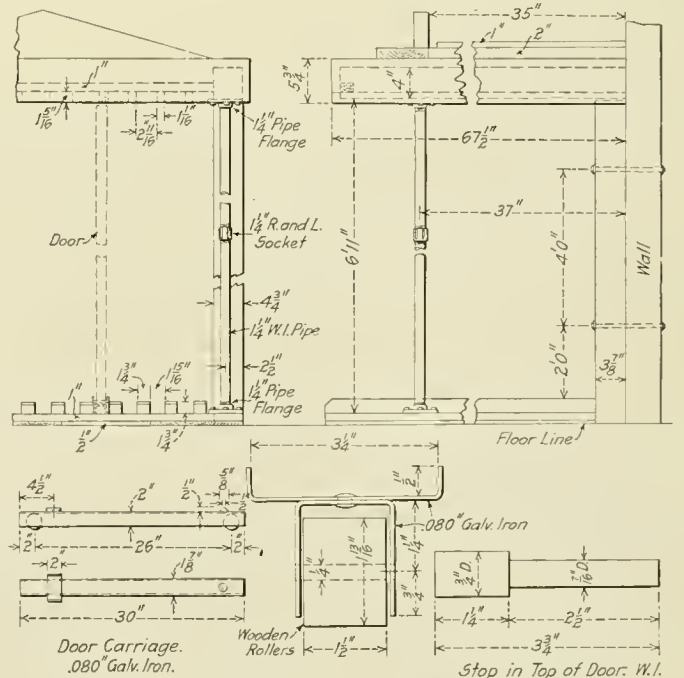

Fig. 2—Rack for Use in Painting Steel Car Doors

funnel and used in connection with slushing the interior of the doors of steel car equipment. The door is placed on the rack and turned at the desired angle, the paint being poured in



through holes in the end. The table is then reversed and emptied, the inside of the door in this way being completely covered. Its simple construction is readily indicated by the drawings, and it is made almost entirely of wood. A wrought iron quadrant  $\frac{1}{4}$  in. thick fitted with pin holes is used to hold the table in its inclined position. A galvanized steel funnel with a bent outlet, as shown is used for pouring the paint into the doors.

Fig. 2 shows a door rack which has proved very efficient and economical. It does away with the repeated handling of the heavy steel doors, as, after being placed on the carriage the door is not again handled, except to be pulled forward from the rack for each paint operation and then pushed back to dry. It can readily be seen that a large number of doors can be handled within a comparatively small space. From the construction it will be noted that the carriage on which the door is placed is 30 to 36 in. long, the wheels being nearly 2 in. in diameter. This permits of moving the doors in and out of the rack readily. A stop is placed in the top of the door, as shown, to keep it in a vertical position while in the rack. The rack is made principally of wood, with  $1\frac{1}{4}$  in. wrought iron pipe supports.

### TOOL CLAMP FOR WHEEL LATHES

BY R. F. GALVERT

A tool clamping device in use on an old style car wheel lathe at the Horton, Kan., shop of the Chicago, Rock Island & Pacific is shown in the illustration. The 8 in. air brake cylinder is fastened to the ceiling above the machine. Air is admitted to the back end of this cylinder, thereby driving the piston forward, which raises the end of the bar *B* by means of the lever and connecting rod *E*, this in turn tending to raise the opposite end of bar *C*. The other end of bar *C* presses down on the tool and securely clamps it. When the full amount of air has been ad-

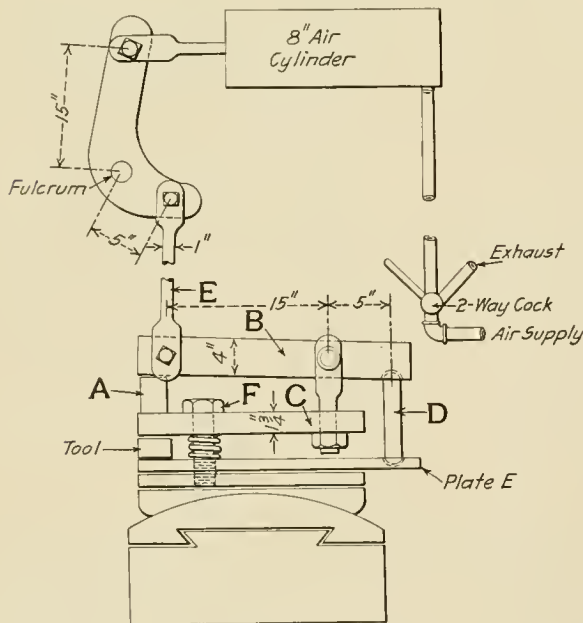

Pneumatic Clamp for Wheel Lathe Tools

mitted and the full compression has been gained on the tool, the block *A* is inserted between the bars *B* and *C*. It will be noted that the space between these two bars will, when in tension, be slightly tapering. The block *A* is, therefore, placed as far back as it will go and the air is exhausted from the cylinder. It is found that a block placed in this way will hold the tool in place.

The part *D* is a round steel bar  $1\frac{1}{2}$  in. in diameter, with rounded ends which fit into sockets in plate *E* and bar *B*. The bolt *F* is one of the original clamping bolts, around which is placed a steel spring to hold bar *C* in place when the tool is not

in use. The cylinder lever is arranged as shown in order to avoid the necessity of packing the piston rod.

### RECLAIMING CAR AXLES

BY ROBERT W. ROGERS

Instructor of Apprentices, Erie Railroad, Port Jervis, N. Y.

A material saving in the cost of car axle renewals may be effected by upsetting worn axles and refinishing them to the next smaller size. An axle having  $5\frac{1}{2}$  in. by 10 in. journals may be upset 1 in. on each end and refinished into a new axle having 5 in. by 9 in. journals,  $4\frac{1}{4}$  in. by 8 in. axles being secured in the same way from worn 5 in. by 9 in. axles.

The special equipment required for doing this work consists of a portable furnace, a small roller table upon which the axles are supported while being heated and an inclined table by which they are handled to a wheel press, where the upsetting is done. The furnace is shown in detail in the accompanying drawing. It is made up of  $\frac{1}{2}$  in. boiler plate lined with fire brick, the top being arched with fire clay as shown in the drawing. The furnace rests upon one end of a four-wheel truck from which it is insulated by  $1\frac{1}{2}$  in. of asbestos lagging. Upon the other end of the truck is placed an oil tank which is piped to a burner located in front of an opening in one side of the furnace. A simple burner built up of a globe valve body and pipe reducers is used. Two 7 in. holes through the wall of the furnace facing the end

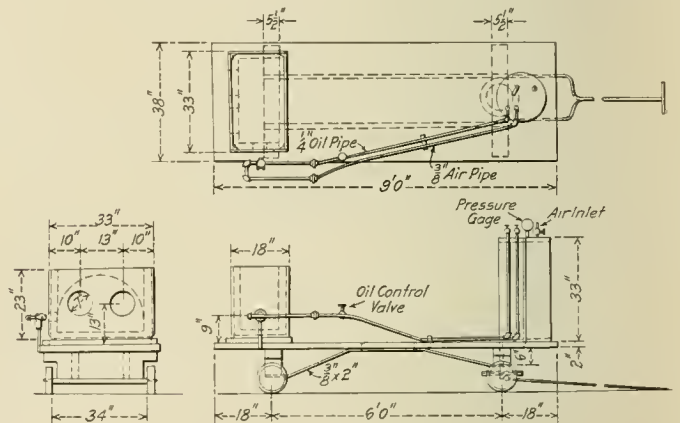

Furnace Used in Reclaiming Car Axles

of the truck are provided for the insertion of the axle. A roller table 31 in. wide by 48 in. long, the frame of which is built up of 2 in. angles is placed in front of the furnace. Two axles at a time are placed upon the table and the ends inserted in the furnace about half the length of the journal. Handling of the axles into and out of the furnace is facilitated by rollers in the top of the table. When the ends of the journals have been brought to a white heat for a length of about 4 or 5 in., they are drawn out of the furnace and rolled down the inclined table to the wheel press where they are handled into the wheel press by an air hoist. The upsetting is done by placing the heated end of the axle against the tailstock of the wheel press and running the ram against the cold end until the proper reduction in length has been made. By this process the end of the journal is upset sufficiently to form a collar for the new journal and it is necessary to remove about  $\frac{1}{2}$  in. of stock in finishing up the journal bearing. The labor of two men is required to supply axles to the furnace and to take them from the furnace to the wheel press. In a shop where a hydraulic press is available the total cost per axle for upsetting, including all labor and fuel, is 35 cents. As the average cost for new axles from 6 in. by 11 in. to  $4\frac{1}{4}$  in. by 8 in. is about \$12.50 each, and the scrap value of worn axles at  $\frac{1}{2}$  cent per pound is about \$4 each, a saving of about \$8.15 is effected for each axle reclaimed ready for turning.

# NEW DEVICES

## CIRCULATING SYSTEM FOR LOCOMOTIVE BOILERS

A device for applying the Ross-Schofield system of circulation to locomotive boilers is being introduced by the Q & C Com-

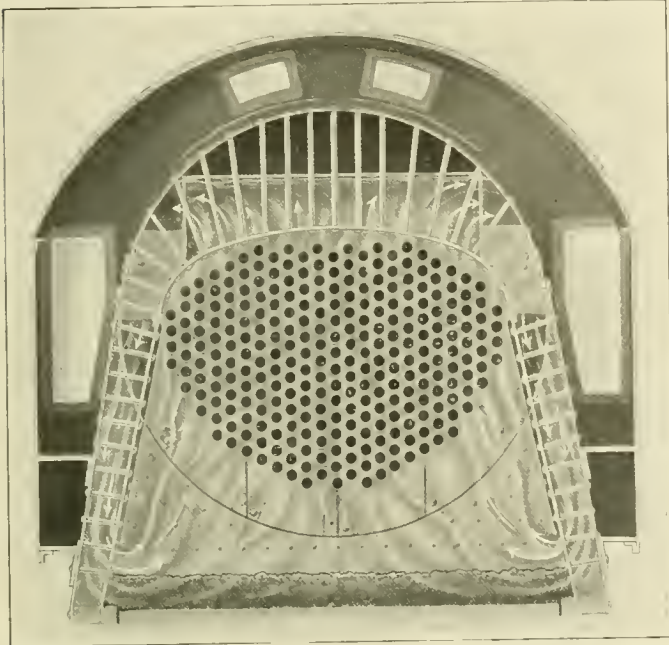

End Elevation, Showing the Direction of Flow from the Barrel of the Boiler

pany, 90 West street, New York. The Ross-Schofield system of circulation was developed and has been in successful use for

some time in marine and stationary service. In this system the circulation is produced by utilizing the force resulting from the separation of the steam from the water. A space is confined about the hottest portion of the heating surface by means of baffle plates, communication with the body of water in the boiler being provided at the top and bottom only. The generation of steam within the water column thus formed produces a rapid upward circulation of the water, provision being made at the surface of the water to properly guide the current thus formed.

The device as applied to locomotives is made up of three parts. A baffle plate which loosely surrounds the tube and separates the barrel of the boiler from the firebox portion is secured to the shell of the boiler at the throat sheet. This extends to a height level with the highest point of the crown sheet, and openings are provided at the sides below the center line of the boiler. The space between the baffle plate and the firebox side sheet is closed by side plates which extend downward to a point about 10 in. above the mud ring. A water column is thus formed which is enclosed by the flue sheet, the baffle plate and the two side plates. All circulation from the barrel of the boiler must pass through the openings in the baffle plate, downward through the water leg to the bottom of the side plates and thence upward over the rear flue sheet and the rear ends of the tubes. Supported to the top of the baffle plate is a curved hood extending up to the normal water line, which directs the circulation over the crown sheet toward the back of the firebox. The water about the firebox thus moves in a circuit; upward across the flue sheet, backward and downward along the crown sheets, side sheet and door sheet, and forward near the bottom of the water legs. As the water in the firebox space is evaporated, more flows in from the barrel of the boiler through the openings in the baffle plate.

Among the advantages which are claimed for this device is increased rapidity of evaporation due to the constant freeing of the heating surface from the steam bubbles by the sweeping ac-

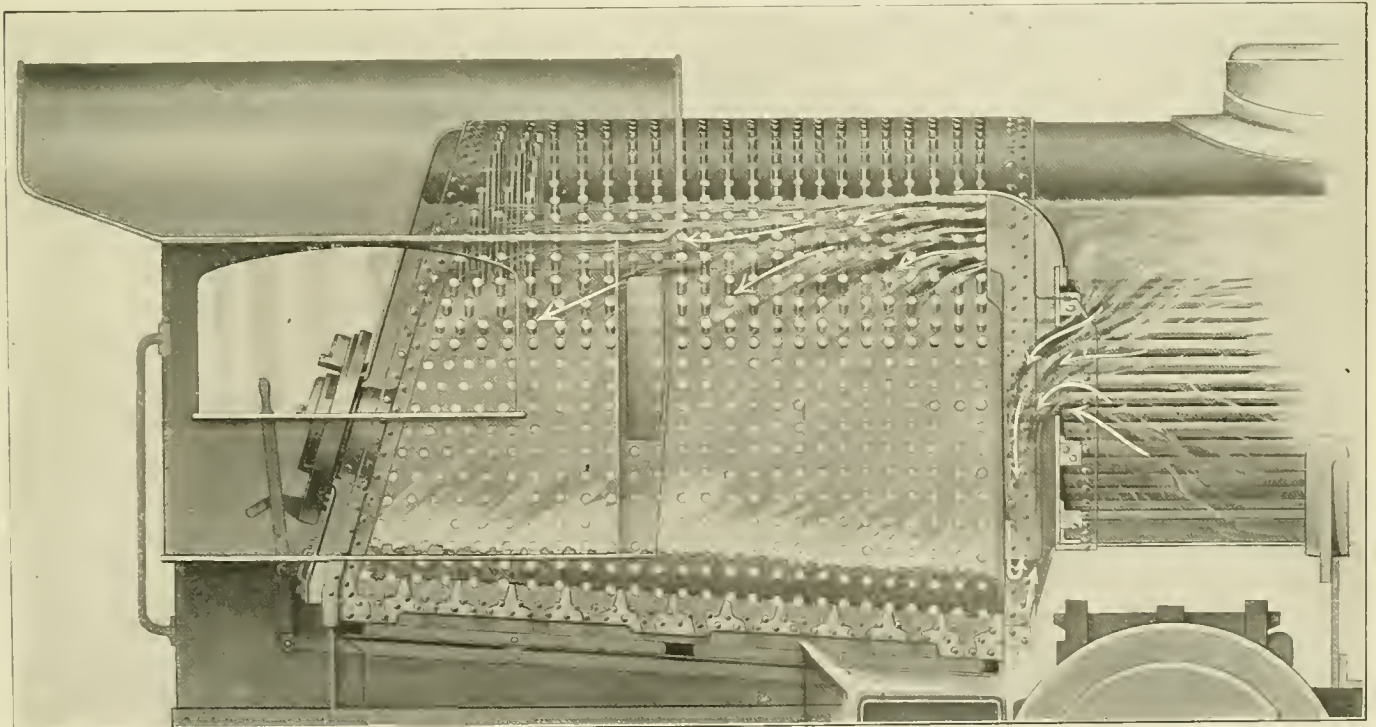

Phantom View of the Ross-Schofield System of Circulation, Showing the Direction of Currents Over the Crown Sheet



tion of the water. Priming which is caused by the violent separation of the steam from the water is overcome by means of the hood which directs the rush of the rising steam and water in a horizontal direction, thus making available the entire surface of the water over the crown sheet for the separation of steam with a consequent decrease in violence of ebullition at any one point. The rapid circulation of the water prevents the formation of stagnant pockets of cold water near the corners of the firebox and produces a uniform temperature at all points around the firebox, thus in a measure reducing the effects of unequal expansion and contraction. It is also claimed that the formation of scale is largely prevented by the rapidity of the circulation, which causes the particles of scale-forming material to collect at the mud ring, where they may be disposed of through the blow-off cock. This is borne out by the result of experience with the system in stationary service.

This device may be readily applied to old boilers whenever the tubes are removed for repairs. The baffle plates may be made in sections of any size suitable to be taken into the boiler through the dome, the parts being assembled inside the boiler before the tubes are applied.

### SAFETY BAGGAGE RACK

The Atchison, Topeka & Santa Fe has placed in service on some of its through passenger train cars a new type of baggage rack designed by the engineer of car construction. These racks were designed to provide ample storage capacity. They are provided with gates which slide on the frame of the rack and serve to keep the bags, parcels, wraps, or whatever may be placed in the rack, in place. The illustration shows the racks installed in one of the day coaches recently built by the Santa Fe, and also shows the way in which the gates are operated by the passengers. There are two gates to each rack, so ar-



Safety Baggage Rack in Santa Fe Coaches

anged that each may be operated independently of the other. The racks are of special advantage, especially on through trains where a considerable amount of hand baggage is often carried by the passengers, in that they will hold more than the ordinary rack now used, and at the same time prevent the luggage from falling on the heads of the passengers. In this way it eliminates damage claims from these causes and provides sufficient capacity to hold all the baggage of the passengers, thus keeping the aisles free from obstruction. The construction is so substantial that the gates will slide easily when the rack is loaded to its full capacity.

### JOURNAL BOX DUST GUARD

The illustrations show a built up dust guard which has recently been introduced by the National Railway Equipment Company, Toledo, Ohio. It is constructed of pressed steel and hard vulcanized fiber; it has a total thickness of about 1/2 in. and is easily inserted in any dust guard compartment. The design is such that it adjusts itself automatically to the movements of the axle while effectively closing the journal box.

The body of the guard is made up of three parts. A movable center of fiber is enclosed in a rectangular pocket formed in a sheet steel case. This pocket is of the same thickness, but otherwise slightly larger than the movable center, thus allowing for adjustment of the fiber center without movement of the case. The edges of the two halves of the case are turned up at a sharp angle and between them is inserted a strip of wool felt which is pressed firmly against the side of the dust guard com-

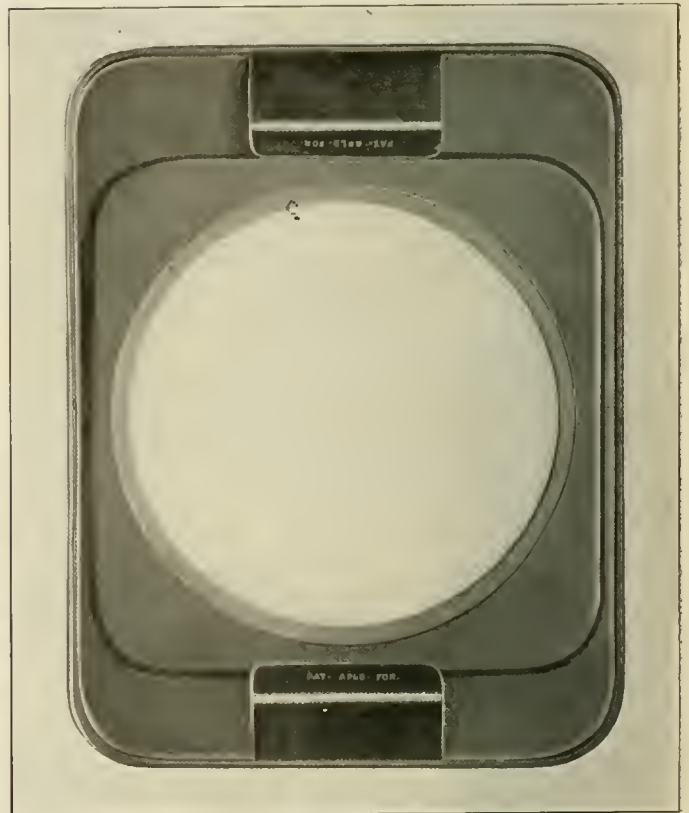

Steel Dust Guard with Adjustable Vulcanized Fiber Center

partment when the guard is in place. This prevents the loss of oil or the ingress of dust between the guard and the box. The fiber center is about 1/4 in. thick, and is so constructed as to allow an expansion of 1/16 in. in the diameter of the axle fit, thus insuring ease of insertion upon the axle. The form of the steel case provides ample strength and rigidity, and it is protected by a permanent rust inhibitive coating. Spring clamps are secured to both the top and bottom on the back side of the case. When in place these firmly press the guards against the side of the compartment and maintain a tight joint around the front face of the guard. They are of sufficient strength to hold it in any desired position, relieving the journal of all unnecessary weight and preventing the rapid wear of the fiber center.

This device has been patented, and is now being tested on a number of railroads. Its simplicity makes it practically unbreakable in service, and its efficiency does not depend upon outside conditions. No plug or stopper is required to close the top of the dust guard compartment because communication with the body of the journal box is closed by the guard itself.

### EMERGENCY JACK

A hydraulic jack, the design of which embodies a number of unusual features, has recently been developed by the Watson-Stillman Company, New York. This jack was designed primarily to meet the demands of an emergency jack for street railway use, but its flexibility of adjustment is such as to make it of value for a variety of purposes wherever lifting work is performed.

The construction of the jack is shown in the sectional elevations, from which it will be seen that the cylinder is the moving part instead of the ram as in the usual type of jack. This allows the pump mechanism to stay in a fixed vertical position and permits the working parts of the jack to be made simpler and more compact than is usually the case. The piston is packed with leather rings and the valves are of the ball type with all passages amply proportioned. The pressure is relieved by means of a key operating a small needle valve. The jack is operated with a special oil, which not only acts as a lubricant, but prevents rust on the working parts and the possibility of freezing. It has no detrimental effect on the packings.

One of the most notable features of this jack is the arrange-

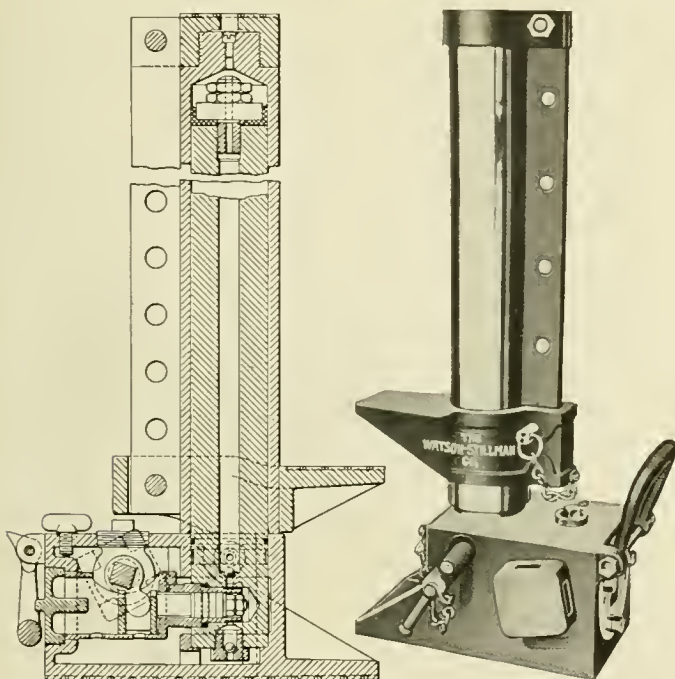

Exterior and Sectional Views of Emergency Jack

ment of the claw which can be moved vertically upon the cylinder and adjusted to the most convenient height. The claw and the cylinder can be swung through a complete circle without changing the position of the jack or the location of the pump. The operating lever is but 18 in. long, but one man weighing 125 lb. can obtain the maximum pressure with but slight effort. The lever is curved and the socket has a hole in each of its four sides to allow for convenience in operation from practically any position. The jacks are now built in five and ten ton sizes with a ram stroke of 10 in., and are guaranteed by the manufacturer to stand a 50 per cent overload without detriment to any of the parts.

**ENDURANCE TESTS FOR AUTOMOBILES.**—Endurance tests for automobiles, the prizes for which are to be orders for winning cars, have been held by the Russian army authorities. The first prize will be an order for 250 cars, the second, an order for 150 cars, the third, for 100 cars, and the fourth, an order for 50 cars.—*Machinery.*

### SQUARE BRAKE SHAFT

Before the safety appliance law went into effect it was the practice of many railroads when manufacturing brake shafts to weld the enlarged chain drum end to the shaft proper, and for repairs, especially at points remote from the principal shops, the practice of welding was almost universally followed. Some railroads which were well equipped with forging and upsetting machines had practiced forming the shafts by upsetting in place of welding; in consequence their cars more nearly meet the requirements

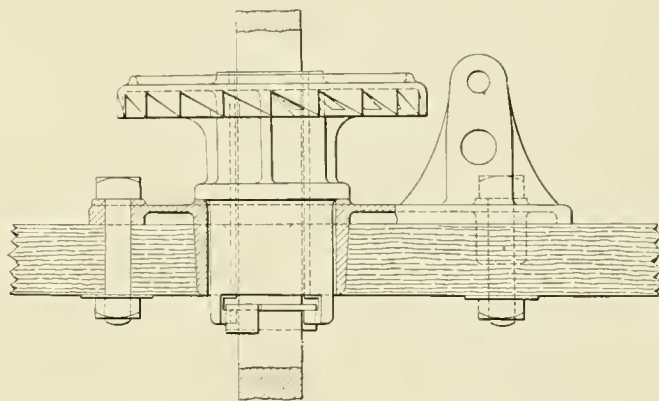

Section Showing Pawl Plate Used on Wooden Brake Steps

of the law in this particular, and they find less difficulty in complying with it than do roads not so fortunately equipped. The manufacture of solid forged brake shafts for thousands of cars, together with the demand for handholds, ladder rounds, etc., is a severe tax on the capacity of railroad blacksmith shops.

When the safety appliance standards of the Interstate Commerce Commission went into effect, the Buffalo, Rochester & Pittsburgh was one of the many roads which found that a large number of its cars had welded brake shafts. The complement of

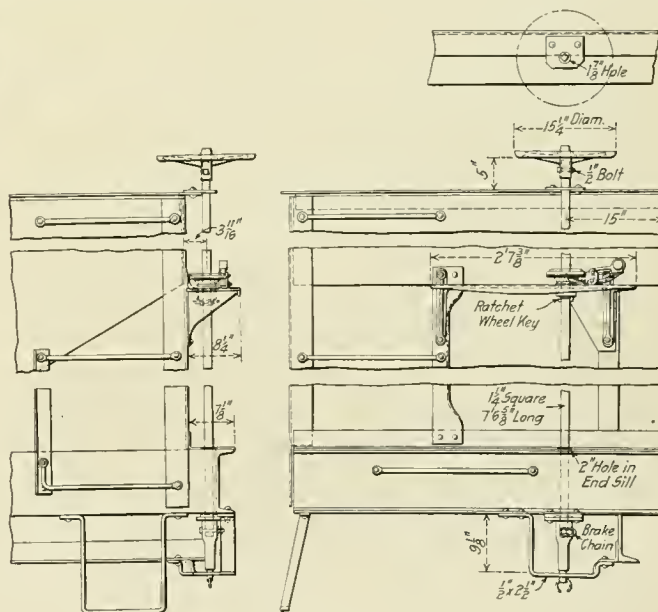

Square Brake Shaft Applied to Gondola Car

forging machines which had been sufficient for ordinary conditions was found insufficient to turn out the requisite number of handholds and brake shafts, and it became necessary either to invest in expensive forging machines and furnaces or to design a brake shaft which dispensed with the upsetting process. The design illustrated was finally developed, by which the upsetting process, the forging down of the ends of the shaft, and thread-





chipping hammer always at hand. To meet these conditions a rivet buster has been developed by the Ingersoll-Rand Company, 11 Broadway, New York City, designed for use in its pneumatic riveting hammers. The end of this tool is interchangeable with the rivet set and when in use is held securely in place by the safety retaining spring used with the rivet set. The chisel end is of a size and shape found to be especially suitable for removing rivets, but it is also useful for removing burrs or other defects from the metal. It is of small size and may be readily carried in the workman's pocket, thus always being at hand when needed.

### OXYGEN TESTING APPARATUS

A simple testing set for rapidly measuring the purity of oxygen has been introduced by the International Oxygen Company, 115 Broadway, New York. It is self-contained, has no complicated or expensive parts, and owing to the accessibility of all parts the liability to damage in cleaning is very small. The method of testing consists in the absorption of oxygen by copper in the presence of ammonia and ammonium carbonate and the removal of the cupreous oxide by the solution. The

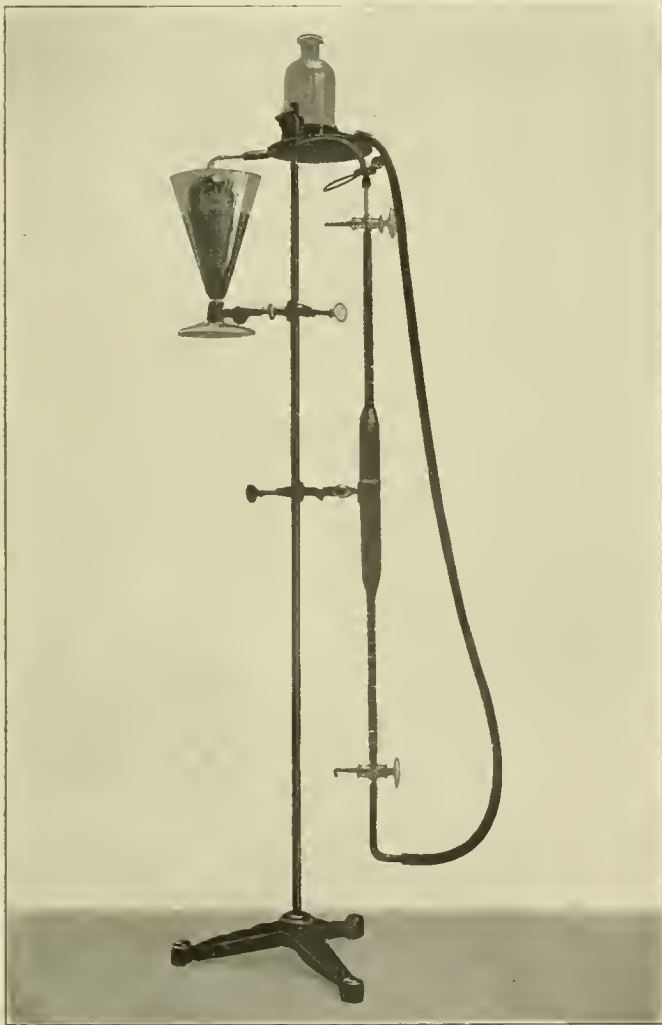

Apparatus for Determining the Purity of Oxygen

apparatus consists of a special burette having a three-way cock at either end, a special absorption pipette and a conical test glass within which the pipette is emersed. An aspirator bottle is connected to the lower end of the burette, and the pipette to the upper end of the burette by means of rubber tubing. A supporting rod and stand is provided to which the parts are secured by clamps as shown in the illustration. In operating the

apparatus the pipette is first filled with 1/32 in. copper wire, after which it is emersed in a solution of ammonia and ammonium carbonate in the conical test glass. After all parts with the exception of the burette have been freed from air by the use of the aspirator bottle the burette is filled with oxygen through the top three-way cock, all air being driven out by opening the lower three-way cock to the atmosphere. After the burette has been filled with oxygen the three-way cocks are closed. By the use of the aspirator bottle the oxygen may then be forced into the pipette, where it is absorbed by the copper. When no further reduction in the volume of the gas takes place the remainder is drawn back into the burette, where the graduations of the scale are so arranged that the percentage of purity may be read directly to 0.1 per cent.

The operation of the apparatus is simple, no skilled labor being required to obtain accurate results. The ammonia-ammonium carbonate solution may be prepared without difficulty by following the directions furnished with the apparatus.

### LOCOMOTIVE FRAME DRILL

A high duty locomotive frame drilling machine recently developed by the Newton Machine Works, Inc., Philadelphia, Pa., has several features not usually included in this class of machine. It is of exceptionally heavy box type construction intended to drive high speed drills to their maximum capacity, and has a weight of approximately 60,000 lb. The cross rail is

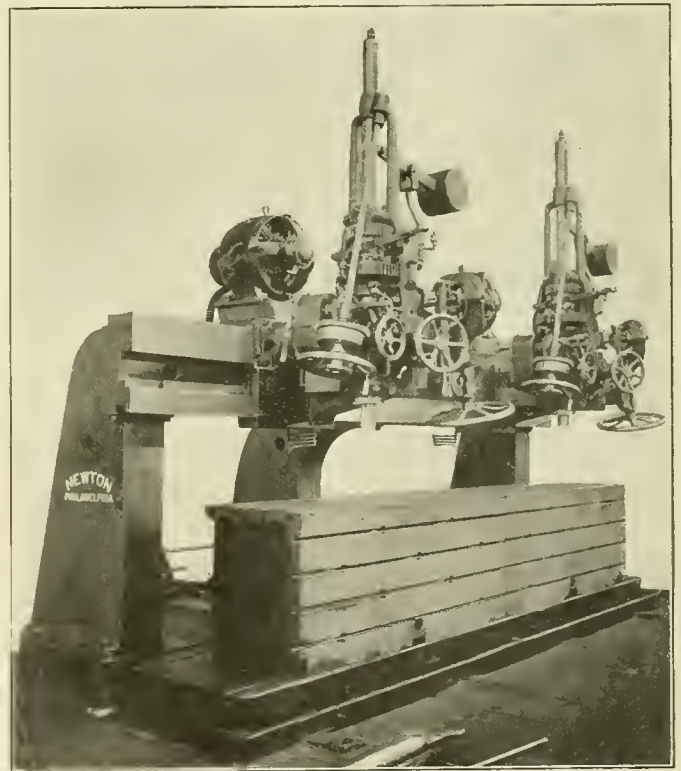

Frame Drill with Top Work Table in Forward Position

rigidly supported by three uprights, the center one of which is placed back of the others to allow clearance for the top work table. This table, which is in two sections, is mounted on the main bed plate, and as shown in the illustration the sections may be moved back, either separately or in unison, to clear the main work table. This movement is controlled by a 5 hp. motor mounted on the back of the base.

The machine has two spindles each driven by a 10 hp. General Electric motor having a speed range from 300 r. p. m. to 1,200 r. p. m. The motor is mounted on and travels with the saddle



and provides a fast reversing power traverse of the saddle on the rail in addition to the hand adjustment. The rail saddle extends forward at right angles to the rail, permitting an in-and-out adjustment of the spindle saddle by hand. The spindles are 4 in. in diameter with a vertical feed of 18 in.; they are counterweighted and have direct and back geared drive. Hand feed and hand adjustment are provided, in addition to four changes of gear feed without the removal of gears.

The maximum distance between the centers of the spindles is 15 ft., the minimum distance being 4 ft. The spindle saddles have an in-and-out adjustment of 15 in., the rear position of

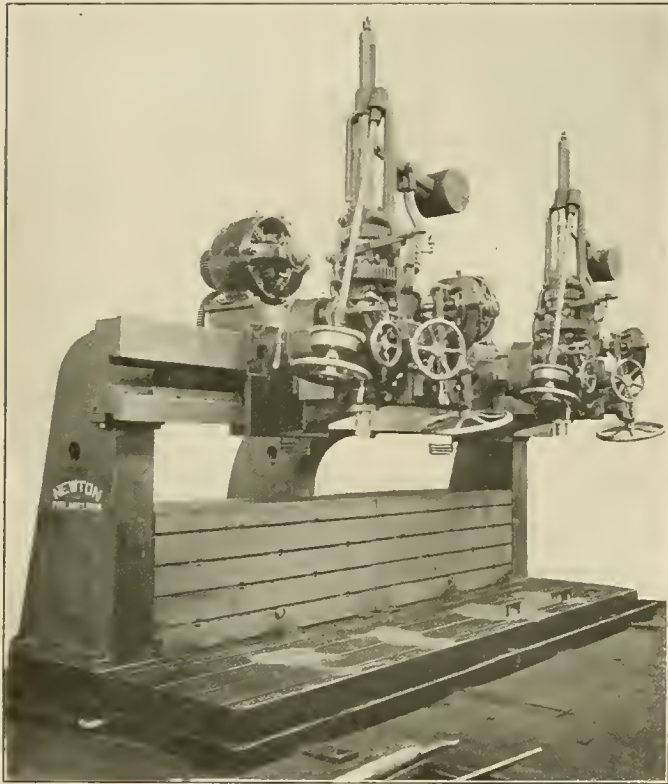

Frame Drill with Top Work Table in Rear Position

the spindle center being  $22\frac{1}{2}$  in. from the front of the top work table when in its rear position. The minimum distance from the end of the spindle to the top of the bed plate is  $32\frac{1}{2}$  in. Each auxiliary work table is 36 in. high and has a top 30 in. wide by 7 ft. 6 in. long.

## SHOP ILLUMINATION BY QUARTZ LAMPS

The accompanying illustrations show the interior of the boiler and erecting shops of the Lake Shore & Michigan Southern at Collinwood, Ohio. As will be noted the photographs were taken at night, and are evidence of an abundance of illumination at all points in the building without glare or shadows. The buildings are 528 ft. long and 58 ft. wide, giving an area of 30,624 sq. ft. in each. The illumination is furnished by the Westinghouse Electric & Manufacturing Company's type Z Cooper Hewitt Quartz lamps operating in a 220-volt direct current circuit. These lamps are a modification of the well-known Cooper Hewitt lamp, based on the same fundamental principles, but using a short-tube of pure fused quartz.

Ten lamps are installed in the boiler shop, placed at regular intervals of 52 ft. down the middle of the building, each lamp lighting an average of 3,062 sq. ft. In the erecting shop there are twelve lamps regularly spaced down the middle of the building at intervals of 44 ft., giving an average floor area lighted by each lamp of 2,552 sq. ft. All the lamps are hung at a height of

50 ft. above the floor. The lamps are rated at 2,400 candle power each with an energy consumption of 725 watts, or a total for the installation of approximately 16 kilowatts.

The light afforded by these lamps is said to be sufficient for all purposes, even the locomotive pit being well illuminated. The



Lake Shore & Michigan Southern Erecting Shop at Collinwood, Ohio, Lighted with Cooper-Hewitt Quartz Lamps

only other form of artificial light required is a portable hand lamp for use inside of boilers. When a trial installation of four lamps was first made, there was some antipathy to the light on the part of the men employed, because of the difference in color



Collinwood Boiler Shop, Showing the Distribution of Light

value, but this speedily disappeared after a thorough trial had been made, and the installation was completed. The lamps have been installed at various times, but the service of the entire installation averages practically 16 months and the maintenance charges for that period total \$134.54, or \$4.58 per lamp per year.

# NEWS DEPARTMENT

Track foremen of the Philadelphia & Reading have been appointed fire wardens by the Pennsylvania State Department of Forestry.

The Atchison, Topeka & Santa Fe, on November 10, had the largest commercial freight loading in its history. A total of 5,229 cars were loaded on the entire system that day, compared with the previous record of 5,204.

The Chicago, Milwaukee & St. Paul cleaned and disinfected 5,000 stock cars between November 12 and November 23. It is also cleaning and disinfecting all its stock yards in quarantine territory, in accordance with government orders issued as a precaution against the spreading of the hoof-and-mouth disease.

The Wabash is printing on all of its working timetables a large "Safety Always" emblem and the following in large type: "Safety should be the first consideration of every employee. Every employee should report promptly to his foreman, some member of the safety committee or other proper person, every unsafe condition."

There are 77 men who have worked for the Pennsylvania Railroad 50 years or more and are young enough to be still busily working. Two of them have records of more than 56 years; two others have served 55 years; two, 54 years; seven, 53 years; six, 52 years, and twenty, 51 years. Of the 77 men five are conductors and eight are enginemen.

Four locomotives on the Louisville-St. Louis division of the Southern Railway are to bear the names of the enginemen who run them. The names will be painted in gilt letters, along with the number of the engine. The men who have been thus recognized are Frank Busching, William Hanafee, Robert Greenlaw and Daniel Shine. The requirement for the distinction is 25 years of efficient service.

The owners of the Atlantic Southern, extending from Atlantic to Villisca, Iowa, 35 miles, have given public notice of their intention to discontinue operation on December 31, claiming that the road has been operated at a loss. It is reported that the people in the towns along the line are preparing to enter a protest before the State Railroad Commission against the closing of the line.

The Railroad Commission of Georgia, realizing the present serious financial predicament of the railroads, has written a letter to the Southern Railway to the effect that in view of the material decrease in the revenues of carriers the commission, until the present financial situation is relieved, will not impose on any of the roads any expenditures for new stations, warehouses, terminal facilities, etc., except such as are absolutely necessary.

The golden spike marking the closing of the last gap in the line of the Northwestern Pacific from San Francisco to Eureka, Cal., 283 miles, was driven at Cain Rock Crossing, Cal., 80 miles southeast of Eureka, on October 21, with appropriate ceremonies, and the first through passenger train was run over the line on the same day. The road is owned jointly by the Southern Pacific and the Atchison, Topeka & Santa Fe.

Postal service has been established on the Grand Trunk Pacific through to the Pacific Coast, and Prince Rupert now receives mail from the east in two days' less time than before. Hitherto the mails have been carried by steamer from Vancouver. The distance from Liverpool to Yokohama by way of the Grand Trunk and Prince Rupert is 10,085 miles, said to be 773 miles less than the distance by way of New York and San Francisco.

Following the election at which the voters of Missouri decisively defeated the full crew bill by referendum vote, the St. Louis & San Francisco announced that its shops at Springfield, Mo., would immediately be placed on a working basis of six days a week and eight hours a day. The main shops have been on a five-day schedule for several months and other shops have been operated only intermittently. Additional men also were given employment.

It has been decided to improve the opportunities of the apprentices at small terminals on the Grand Trunk, where it has not been possible to keep instructors. Correspondence courses, mapped out along approved lines, have been adopted for this purpose and the boys will be in touch in these studies with the headquarters in Montreal. Text books have been compiled, both in drawing and mechanics, and these have been made as practical as possible, so that the practical work may line up with the theory taught.

At the safety congress of the National Council for Industrial Safety, held in Chicago on October 14 and 15, there were present from the Chicago & Northwestern one delegate from each division, terminal shop and local safety committee, all making the trip as the guests of the company, 52 men in all. The delegates have adopted resolutions stating that they obtained much valuable knowledge and information at the meeting, which will be a great help in promoting the safety first work on the Northwestern; and thanking President Gardner and Vice-President Aishton for arranging the trip.

The National Transcontinental Railway, over which trains are running from Moncton, N. B., northwest to Escourt, 56 miles beyond Edmundston, is shortly to be put in operation between Moncton and Levis, opposite Quebec. Trains between Moncton and Escourt are operated by the Intercolonial and the Intercolonial will manage the extended service. The whole of the National Transcontinental is now finished, so as to be ready for use, but the arrangement by which the Grand Trunk Pacific was to operate the road appears to have encountered some obstacle. According to the *Toronto World*, the line west of Levis is likely not to be put in use until next spring.

Fairfax Harrison, president of the Southern Railway, speaking at Atlanta, Ga., recently, said that the severe retrenchment made necessary by the falling off in traffic would be continued, even to the extent of depriving passengers of some of the luxuries and conveniences which they have been accustomed to. The gross receipts of the railway company in September were 8.33 per cent less than in the same month of last year, and in October the decrease was 18.75 per cent. Curtailment of expenses has been necessary, in some cases, as a "war measure," even where it was uneconomical to make the reduction. Both the officers and the employees of the company have to stand serious losses. He believes that the present severe stress will be temporary and new construction work, provided for by capital which was raised last spring, has not been suspended.

Complete official figures show that the majority given by the voters of Missouri against the full crew bill was three times as great as was shown in the estimate based on the early returns; 324,085 votes against and 159,593 in favor, a majority of 164,492 in opposition to the bill. This makes the vote more than two to one against the law. Outside of the three principal cities, St. Louis, Kansas City and St. Joseph, the measure received only 86,660 votes in the state, and was beaten by a ratio of about three to



one. The farmers in every section of the state voted almost solidly against it. St. Louis, in which the Brotherhood looked for a big majority in favor of the bill, went against it by 18,417. In Kansas City and in St. Joseph it was carried. The majority against the bill is one of the greatest in the history of Missouri and is larger than the state has ever given to any candidate.

#### CORRECTION

In an article on the Four Feed Flange Oiler published in the November issue of the *Railway Age Gazette, Mechanical Edition*, on page 600, the name of the company manufacturing this device was incorrectly stated. It should have been the Ohio Injector Company, Monadnock building, Chicago, Ill.

#### TRAMPS BY THE TRAIN LOAD

A press despatch from San Bernardino, Cal., November 16, says that 93 tramps, on their annual winter tour westward, are in jail at that place, charged with having seized a San Pedro, Los Angeles & Salt Lake freight train on the Mojave desert. The tramps, more than a hundred strong, overpowered the trainmen, when the train entered Otis, broke the seals of freight cars and after making themselves comfortable, ordered the engine man to proceed to Los Angeles. A posse was waiting for the train at San Bernardino, and all but ten of the tramps were captured.

#### ARBITRATORS IN WESTERN ENGINEMEN'S AND FIREMEN'S CONTROVERSY

The arbitration board, to consider enginemen's and firemen's wages on the western roads, has finally been completed, after months of delay, and hearings have begun at Chicago. The arbitrators are: H. E. Byram, vice-president of the Chicago, Burlington & Quincy; W. L. Park, vice-president of the Illinois Central; F. A. Burgess, assistant grand chief of the Brotherhood of Locomotive Engineers; Timothy Shea, assistant to the president of the Brotherhood of Locomotive Firemen and Enginemen; Charles Nagel, ex-secretary of Commerce and Labor, and Jeter C. Pritchard, presiding judge of the United States Court of Appeals of the Fourth Circuit.

#### ELECTRIFICATION ON THE ST. PAUL

Construction work in connection with the electrification of the Chicago, Milwaukee & St. Paul between Harlowton, Mont., and Avery, Idaho, has been resumed. Thus far the poles have been placed for a distance of 30 miles on the 116-mile division between Three Forks and Deer Lodge, Mont., which is the first to be equipped. The company has ordered nine freight and three passenger electric locomotives from the General Electric Company. These locomotives will be of the same construction except that those to be used for passenger service will be geared for a higher speed. The total weight of these locomotives will be 519,000 lb. each, and the weight on drivers 400,000 lb. They are to be delivered in October, 1915, at which time, it is planned, the construction work over the entire line will have been completed.

#### CREDIT FOR SAVING SCRAP

Bulletins telling of specially meritorious acts on the part of employees have an added interest where the persons named in them are known; and the smaller the territory covered by a bulletin, the more likely are the employees generally to recognize the names published. W. T. Lechliden, superintendent of the Cleveland division of the Baltimore & Ohio, issues bulletins, once a month, or as often as may be found desirable, which are confined to happenings on his own division. One of the things noted in a recent bulletin was the commendation of a baggage master for making neat and comprehensive reports. The station forces at three places, and a

dozen individual trainmen and section foremen were commended for saving scrap, the value of which, in two weeks, amounted to \$218.

#### A DISHONEST CLAIM AGENT PUNISHED

In the United States District Court at Baltimore recently, George Elmer Long was convicted on five counts of defrauding the Baltimore & Ohio Railroad by bogus claims paid by Long while in the employ of the road. Long will serve three years in the federal penitentiary at Atlanta. He entered the employ of the Baltimore & Ohio about three years ago as a claim adjuster in the freight department, having had previous experience with southern roads. For some time after securing the position he was establishing himself in the confidence of superiors, after which, through the medium of confederates, a scheme of filing fraudulent claims was undertaken. The accomplices represented themselves as shipping concerns and made claims for losses or damage to shipments never shipped, and others which were shipped and contained only junk. In his confession Long admitted shipping four boxes as the property of different concerns. In most instances, however, no shipment was even made, the plan having been that where legitimate claims were adjusted the waybills were stolen and changed to cover shipments to firms existing only in the minds of the gang and on the stationery which they used. The claims varied usually in amounts ranging from \$200 to \$500. Long was tracked by Edmund Leigh, chief of the railroad detective force, the chase having been conducted in Pittsburgh, Niagara Falls, Hamilton, Chicago and Detroit. Long was arrested in Detroit while calling for mail at the post office.

#### OPENING OF THE KANSAS CITY UNION STATION

The new Union station of the Kansas City Terminal Railway, Kansas City, Mo., was formally dedicated with a two days' celebration, held under the auspices of the Kansas City Commercial Club. The mayor declared a half-holiday on Friday, October 30. The formal dedication of the station was held on Friday afternoon and the station was actually opened to traffic at 12:01 a. m., Sunday, November 1. The program on Friday began with a manufacturers' parade in the morning, consisting of 140 floats, 16 bands and motor cars carrying officers of the Commercial Club. The parade was nearly two miles long. In the afternoon was held a civic parade, including members of the principal commercial organizations of the city and representatives of the railways. Following this parade the opening was held at the station, when President H. H. Adams of the Kansas City Terminal Railway Company, formally presented the station to Kansas City. Mayor Jost responded with a speech of acceptance. In the evening a dinner was given by the Commercial Club to the officers of the railways at the Hotel Baltimore, and later in the evening a display of fireworks and a final illumination of the old station was given from the hill opposite the new Union Station. The Saturday program included a golf tournament for the visiting railway men, followed by a luncheon and a motor ride about the city.

It was estimated by the newspapers that the largest crowd ever assembled at Kansas City attended the opening of the new station. The dinner of the Commercial Club was attended by the presidents and other executive officers of the 12 roads which are partners in the new station, and by nearly 100 other prominent railway officers, and the principal city officers and business men of the city, including two former mayors of the city. Among the speakers were Hale Holden, president of the Chicago, Burlington & Quincy; B. F. Bush, president of the Missouri Pacific; B. L. Winchell, director of traffic of the Union Pacific; E. B. Pryor, receiver of the Wabash, and Gardiner Lathrop, general solicitor of the Atchison, Topeka & Santa Fe. Most of the speakers lauded the

railroads for their enterprise in building such a magnificent station, adequate to the demands of a city several times the size of Kansas City; and many speakers spoke of the justice of co-operating with the railroads in the future.

**MEETINGS AND CONVENTIONS**

*International Railway General Foremen's Association.*—William Hall, secretary-treasurer of the International Railway General Foremen's Association has changed his address from 914 to 1126 West Broadway, Winona, Minn.

*International Railway General Foremen's Association.*—An important meeting of the officers, and members of the executive committee of the International Railway General Foremen's Association, will be held at the Hotel Sherman, Chicago, Tuesday, December 8, 1914, at 10 a. m. As matters of great importance to the organization are to be considered, it is earnestly desired that all concerned will make an effort to be present.

*New York Railroad Club.*—At the meeting of the New York Railroad Club in New York on November 20, Frederick C. Syze, trainmaster of the Baltimore & Ohio at St. George, Staten Island, N. Y., was elected president, succeeding George W. Wildin. Other officers elected were: Burton P. Flory (N. Y. O & W.), first vice-president; James Milliken (P. B. & W.), second vice-president; A. J. Stone (Erie), third vice-president, and R. M. Dixon, treasurer. The report of the secretary shows that during the year the club had gained 318 new members and that on November 1, the membership was 2,364.

*International Engineering Congress.*—Announcement has been made of the program for the International Engineering Congress to be held in San Francisco, September 20 to 25, 1915, under the auspices of the American Society of Civil Engineers, the American Institute of Mining Engineers, the American Society of Mechanical Engineers, the American Institute of Electrical Engineers, and the Society of Naval Architects and Marine Engineers. In spite of the condition now prevailing in Europe the committee of management is in receipt of a sufficient number of communications from various foreign countries to indicate that a large majority of the papers originally requested for presentation at the sessions of the congress will be handed in on time and that the congress will be truly international in character. The total number of papers contemplated was about 290. Of this number about 220 are either definitely promised or well assured. The remainder, apportioned chiefly among the nations in the present war zone, are uncertain and it is expected that some of them will not be secured, but it is believed that by substituting for these others that have been offered the general plan for the congress may be carried out with a minimum of change.

*Railway Business Association.*—Fairfax Harrison, president of the Southern Railway, and Warren G. Harding, United States senator-elect from Ohio, are announced as the speakers for the sixth annual dinner of the Railway Business Association, the national organization of manufacturers, merchants and engineers dealing with steam railroads, which will be held at the Waldorf-Astoria hotel. New York, Thursday evening,

December 10. The business meeting of the association will be held at 11 a. m. at the hotel, the election of officers at 1.30 p. m. and the dinner at 7, the doors opening exactly on the hour. The circular announcing the names of the speakers says in part:

"Mr. Harrison unites long experience and responsibility as a railway official with the oratorical art of the attorney. Practiced for many years in the study of public opinion as it affects the prosperity of the railways, he is a leader in the cultivation of friendly sentiment and cordial co-operation between railway managers and the people whom they serve.

"Mr. Harding is a journalist with substantial business interests. During several years of legislation affecting business and transportation he has given constant admonition, caution and counsel lest industry and commerce be shackled and the public welfare impaired. On that platform he has now been chosen by the people of Ohio as their senator in Congress. The obligation of government to promote national prosperity will furnish the keynote of his address, while his brilliant endowment as a writer and speaker complete the promise of a message appetizing in form as well as invigorating in substance.

"Subscribers to the dinner as this circular goes to press exceed those upon the corresponding date in 1913. Such response to an announcement not naming the speakers and at a time like the present is a display of enthusiasm by our members which proves anew their belief in the cause and their loyalty to the work."

*The following list gives names of secretaries, dates of next or regular meetings, and places of meeting of mechanical associations.*

- AIR BRAKE ASSOCIATION. F. M. Nellis, 53 State St., Boston, Mass. Convention, May 5-7, 1915, Hotel Sherman, Chicago.
- AMERICAN RAILWAY MASTER MECHANICS' ASSOCIATION.—J. W. Taylor, Karpen building, Chicago. Convention, June 9-11, 1915, Atlantic City, N. J.
- AMERICAN RAILWAY TOOL FOREMEN'S ASSOCIATION.—Owen D. Kinsey, Illinois Central, Chicago. Convention, July 1915, Chicago.
- AMERICAN SOCIETY FOR TESTING MATERIALS.—Prof. E. Marburg, University of Pennsylvania, Philadelphia, Pa.
- AMERICAN SOCIETY OF MECHANICAL ENGINEERS.—Calvin W. Rice, 29 W. Thirty-ninth street, New York. Convention, December 1-4, 1914, New York.
- CAR FOREMEN'S ASSOCIATION OF CHICAGO.—Aaron Kline, 841 North Fiftieth Court, Chicago; 2d Monday in month, except July and August, Lytton building, Chicago.
- CHIEF INTERCHANGE CAR INSPECTORS' AND CAR FOREMEN'S ASSOCIATION.—S. Skidmore, 946 Richmond street, Cincinnati, Ohio.
- INTERNATIONAL RAILWAY FUEL ASSOCIATION.—C. G. Hall, 922 McCormick building, Chicago. Convention, May 17-20, 1915, Chicago.
- INTERNATIONAL RAILWAY GENERAL FOREMEN'S ASSOCIATION.—William Hall, 1126 W. Broadway, Winona, Minn. Convention, July, 1915.
- INTERNATIONAL RAILROAD MASTER BLACKSMITHS' ASSOCIATION.—A. L. Woodworth, Lima, Ohio. Convention, August 17, 1915, Philadelphia, Pa.
- MASTER BOILER MAKERS' ASSOCIATION.—Harry D. Vought, 95 Liberty street, New York. Convention, May 26-28, 1915, Chicago, Ill.
- MASTER CAR BUILDERS' ASSOCIATION.—J. W. Taylor, Karpen building, Chicago. Convention, June 14-16, 1915, Atlantic City, N. J.
- MASTER CAR AND LOCOMOTIVE PAINTERS' ASSOC. OF U. S. AND CANADA.—A. P. Dane, B. & M., Reading, Mass. Convention, September, 14-17, 1915, Detroit, Mich.
- NIAGARA FRONTIER CAR MEN'S ASSOCIATION.—E. Frankenberger, 623 Brisbane building, Buffalo, N. Y. Meetings monthly.
- RAILWAY STOREKEEPERS' ASSOCIATION.—J. P. Murphy, Box C, Collinwood, Ohio. Convention, May 17-19, 1915, Hotel Sherman, Chicago.
- TRAVELING ENGINEERS' ASSOCIATION.—W. O. Thompson, N. Y. C. & H. R., East Buffalo, N. Y. Convention, September 1915, Chicago, Ill.

**RAILROAD CLUB MEETINGS**

Club	Next Meeting	Title of Paper	Author	Secretary	Address
Canadian	Dec. 8	Maximums and Minimums in Train Operation	A. Price	James Powell	Room 13, Windsor Hotel, Montreal.
Central	Jan. 8	Electric Railway Night		Harry D. Vought	95 Liberty St., New York City.
New England	Dec. 8	European War and Its Effect on Business	W. R. Balch	Wm. Cade, Jr.	683 Atlantic Ave., Boston, Mass.
New York	Dec. 18	Annual Smoker		Harry D. Vought	95 Liberty St., New York City.
Pittsburgh	Dec. 14	Notes on Transportation in Europe	A. Stucki	J. B. Anderson	207 Penn. Sta., Pittsburgh, Pa.
Richmond	Dec. 14	A Talk by the Presidents of C. & O. and R. F. & P.		F. O. Robinson	C. & O. Ry., Richmond, Va.
St. Louis	Dec. 11	Benefits of the Relief Department to a Railway	S. R. Parr	B. W. Franenthal	Union Station, St. Louis, Mo.
Southern & S'w'rn	Jan. 21	Electric Welding		A. J. Merrill	218 Grant Bldg., Atlanta, Ga.
Western	Dec. 15	The Possibility of Fire from Locomotive Sparks	Prof. L. W. Wallace	Jos. W. Taylor	1112 Karpen Bldg., Chicago, Ill.



## PERSONALS

*It is our desire to make these columns cover as completely as possible all the changes that take place in the mechanical departments of the railways of this country, and we shall greatly appreciate any assistance that our readers may give us in helping to bring this about.*

### GENERAL

H. C. OVIATT, until recently superintendent of the Old Colony division of the New York, New Haven & Hartford, has been appointed assistant mechanical superintendent in charge of the Bureau of Fuel Economy, just established, with office at New Haven, Conn.

J. J. SULLIVAN has been appointed superintendent of machinery of the Nashville, Chattanooga & St. Louis, with headquarters at Nashville, Tenn., to succeed A. G. Kantman, resigned to devote his time to private affairs.

### MASTER MECHANICS AND ROAD FOREMEN OF ENGINES

H. B. HAYES, master mechanic of the Cincinnati, New Orleans & Texas Pacific at Somerset, Ky., has been transferred to Birmingham, Ala., as master mechanic of the Alabama Great Southern.

W. E. MOHER has been appointed traveling locomotive foreman of the Grand Trunk Pacific, with headquarters at Transcona, Man.

H. F. STALEY, formerly master mechanic of the Carolina, Clinchfield & Ohio, has been appointed master mechanic of the Boyne City, Gaylord & Alpena at Boyne City, Mich.

A. STURROCK has been appointed district master mechanic of the Canadian Pacific, with office at Nelson, B. C., succeeding A. Mallinson.

### CAR DEPARTMENT

T. J. BUTLER has been appointed car foreman of the Rock Island Lines at Herington, Kan., succeeding A. L. Clem, promoted.

J. L. CANTWELL has been appointed general foreman of the Southern Railway at Asheville, N. C. He entered the service of Southern Railway as machinist at Birmingham in January, 1906, which position he held until June of the same year, when he was appointed erecting shop foreman. He was transferred to Inman as assistant foreman in October, 1906, and returned to Birmingham in December of the same year as erecting shop foreman. In January, 1909, he was promoted to general foreman at Princeton, Ind., which position he held until he was transferred to Asheville as general foreman.

J. S. EASTERLY, chief car inspector of the Southern Railway at Citico, Tenn., has been promoted to foreman of the freight car repairs at the Coster (Tenn.) shop.

J. F. LEAKE, formerly foreman of freight car repairs at the Coster, Tenn., shop of the Southern Railway, has been appointed chief joint inspector at Chattanooga, Tenn., representing the Alabama Great Southern; Cincinnati, New Orleans & Texas Pacific and Southern.

W. D. LYLE, a car inspector of the Southern Railway, has been appointed chief car inspector at Citico, Tenn.

W. F. WEIGMAN has been appointed general foreman of the car department on the Charleston & Western Carolina, with headquarters at Augusta, Ga.

### SHOP AND ENGINE HOUSE

W. H. BURLEIGH has been appointed roundhouse foreman of the Rock Island Lines at Armourdale, Kan.

A. M. LAWHON has been appointed general foreman of the

Southern Railway at Princeton, Ind. He entered railroad service as machinist in September, 1890. In September, 1899, he was promoted to night roundhouse foreman, serving in this capacity for three years, and as day roundhouse foreman for six years, when he resigned. He re-entered the service of the Southern Railway as machinist at Coster, Tenn., October, 1912, and one year later was promoted to assistant roundhouse foreman, which position he held three months, being transferred to Princeton as erecting and machine shop foreman, holding this position until his appointment as general foreman.

J. H. ORTH has been appointed machine shop foreman of the Southern Railway at Princeton, Ind.

D. E. SMITH, formerly locomotive foreman of the Grand Trunk Pacific at Biggar, Sask., has been appointed locomotive foreman at Regina, Sask., succeeding A. S. Wright.

W. B. TROW has been appointed general foreman of the Rock Island Lines at Armourdale, Kan., succeeding E. P. Eich, assigned to other duties.

A. S. WRIGHT, formerly locomotive foreman of the Grand Trunk Pacific at Regina, Sask., has been appointed locomotive foreman at Biggar, Sask., succeeding D. E. Smith.

### PURCHASING AND STOREKEEPING

O. NELSON has been appointed traveling storekeeper of the Union Pacific, with headquarters at Omaha, Neb.

A. E. YULL has been appointed tie and timber agent of the Canadian Northern, with jurisdiction over eastern lines, with headquarters at Toronto, Ont.

### OBITUARY

JAMES BISSETT, formerly master mechanic of the South Side shops of the St. Louis & San Francisco at Springfield, Mo., died in Springfield, November 11, after an operation. Mr. Bissett was born in Dunfermline, Scotland, May 15, 1840, and came to the United States with his parents when he was 10 years old. He entered railway service at the age of 14 as a water boy on the North Madison Railway at North Madison, Ind., and later entered the railway shops there where he received his early training as a machinist. His next position was that of locomotive fireman, and with the outbreak of the Civil War Mr. Bissett enlisted and was detailed to a railway corps of the Confederate army. He served during the war, and afterwards was in the employ of a number of railways in the United States until October, 1899, when he opened what are now known as the South Side shops of the Frisco, this part of the system at that time being the Kansas City, Ft. Scott & Memphis. He remained as master mechanic of these shops until two years ago when he retired on a pension.

## NEW SHOPS

GRAND TRUNK PACIFIC.—A contract has been given to Carter, Halls & Alinger, Winnipeg, Man., at \$300,000, it is said, for constructing terminals at Prince George, at Endako, at Smithers and at Pacific. The construction work has already been started and will include roundhouses, machine shops and other railway buildings. The company will probably let a contract soon for similar work at Prince Rupert, the coast terminus.

SOUTHERN RAILWAY.—This company will start work at once on new engine terminal facilities at Denverside, near East St. Louis, at a cost of about \$275,000, and is asking for bids for the construction of an 18-stall roundhouse, shops and other buildings. The improvements also include a 90-ft. turntable, modern coal and cinder handling plant, oil house, office building, etc., and the construction of repair yard tracks and other track work. The grading work for the tracks is now under way.

## SUPPLY TRADE NOTES

C. E. Harrison has resigned as co-receiver of the Barney & Smith Car Company, and H. M. Estabrook will continue as sole receiver.

The American Car & Foundry Company has announced that its plants at St. Louis, Mo., and Madison, Ill., will be closed on December 1.

H. C. Hequembourg, having resigned as general purchasing agent of the American Locomotive Company, the purchasing and storekeeping departments will be under the jurisdiction of Leigh Best, vice-president.

Eli F. Hart, one of the founders and the chairman of the board of the Rodger Ballast Car Company, Chicago, died at his home in Chicago on November 23. Mr. Hart was born at Rochester, N. Y., in 1832.

After sixteen years service with Hermann Boker & Co., New York, Ellsworth Haring has terminated his connection with that company, and has organized a business in tool steel and related specialties, with temporary offices at 684a Hancock street, Brooklyn, N. Y.

J. A. Smythe has been appointed boiler expert of the Lukens Iron & Steel Company, and the Jacobs-Shupert U. S. Firebox Company, with headquarters at Coatesville, Pa. Mr. Smythe was formerly associated with the Parkesburg Iron Company, Parkesburg, Pa., in a similar capacity.

A. L. Moler has been elected vice-president, manager and a director of the Durbin Train Pipe Connector Company, Ltd., Montreal, Que. Mr. Moler has been connected with several large railways as master mechanic and superintendent of motive power in the course of the past 16 years.

H. C. Hequembourg, who has been the general purchasing agent of the American Locomotive Company since its organization, has resigned to accept the vice-presidency of the Standard Chemical Company, Pittsburgh, Pa. This company is said to be the largest producer of radium in the world.

W. E. Magraw, president and treasurer of the Railway List Company, the Railway Master Mechanic, and Railway Engineering and Maintenance of Way, Chicago, died on Tuesday, November 24, following an operation for appendicitis. Mr. Magraw was born in St. Peter, Minn., in 1858, and was for many years western advertising manager of the Railway Review. He leaves a widow and two daughters.

Dr. J. A. L. Waddell and John Lyle Harrington announce the dissolution of the firm of Waddell & Harrington, consulting engineers, Kansas City, Mo. The firm's business will be conducted as usual till the conclusion of its affairs in July, 1915, except that it is accepting no new commissions. Dr. Waddell will give his attention to special engineering and financial matters, and to important advisory work. Mr. Harrington will become a member of the new firm of Harrington, Howard and Ash, as noted elsewhere.

John Lyle Harrington, E. E. Howard and Louis R. Ash have established the firm of Harrington, Howard & Ash, with office in the Orear-Leslie building, Kansas City, Mo., and will conduct a general consulting practice relating to hydro-electric developments, advisory municipal engineering appraisals, examinations, and reports upon engineering projects, giving special attention to foundations, bridges—particularly movable spans—and other structures in steel and reinforced concrete. Mr. Harrington spent many years in bridge and structural shops, two of which he designed and operated, in the service of railroad companies, and in mechanical and electrical work. For three years he was the executive engineer of the C. W. Hunt Co., New York, and for two years chief engineer and manager of the Locomotive & Machine Company of Montreal. For the past eight years he

has been a member of the recently dissolved firm of Waddell & Harrington, consulting engineers, Kansas City, and has directed the design and construction of many bridges. Mr. Howard has been associated with Dr. J. A. L. Waddell for fourteen years, for many years as principal assistant engineer, and later as associate engineer of Waddell & Harrington. His experience covers every phase of the firm's work. Mr. Ash has had many years' experience in engineering work, and from July, 1910, to April, 1913, was city engineer of Kansas City, in which capacity he was responsible for the design and construction of sewers, paving, grading, flood protection work, etc. He also made an appraisal of the property of the Metropolitan Street Railway Company, and was engineering adviser for the city in the street railway franchise negotiations. Mr. Ash resigned from the position of city engineer to become associate engineer and office manager of Waddell & Harrington.

George W. Lyndon has been elected president of the Association of Manufacturers of Chilled Car Wheels, with headquarters at Chicago. Mr. Lyndon was born at Rochester,



G. W. Lyndon

N. Y., February 16, 1859. He attended the Kewanee, Ill., high school, graduating in 1877. He was then a law student with Charles K. Ladd, Kewanee, and Turner A. Gill, Kansas City, Mo., until 1880, when he entered railway service with the Kansas Pacific at Kansas City, Mo. shortly thereafter he was transferred to Omaha on account of the consolidation of the Kansas Pacific with the Union Pacific. He remained with the Union Pacific as chief clerk of freight accounts until 1885, then accepted a

position as traveling auditor of the Kansas City, Fort Smith & Memphis, with headquarters at Kansas City. In 1887 he was appointed freight auditor, resigning in 1889 to accept a position as freight auditor of the Chicago, Kansas City & St. Paul, now the Chicago Great Western. In 1890 he resigned to take a position as general auditor of the Griffin Wheel Company and Ajax Forge Company. Later he was made manager of the improvement and review departments, which position he held until 1907. In 1908 he was made western secretary of the Railway Business Association, and in the same year he accepted a position as secretary and treasurer of the Association of Manufacturers of Chilled Car Wheels, which position he held until his election as president on October 27.

THE SAFETY MOVEMENT IN ENGLAND.—The Great Western, of England, recently presented to each of its 80,000 employees a 48-page pamphlet entitled "The Safety Movement." The introduction gives the railway accident statistics for the United Kingdom, showing what proportion were due to want of caution by the men themselves. The book contains many illustrations showing both safe and dangerous methods of doing work on locomotives and rolling stock, in yards and shops, in baggage rooms, on tracks, etc. Safety devices such as goggles and respirators are also described. At the end of the book is a tabulation of one month's personal accidents in the various departments of the railway, accompanied by an appeal to all employees to assist in the safety movement.



## CATALOGS

**FIRE SHOVELS.**—Circular No. 53, issued by the National Malleable Castings Company, Cleveland, Ohio, deals with the malleable iron fire shovels manufactured by this company. Illustrations and a table of dimensions are included.

**ELECTRIC SWITCHBOARDS.**—Bulletin S1, issued by the Western Electric Company, 463 West street, New York, is devoted to Western Electric switchboards, and has been issued especially for the Central and South American trade. It is completely illustrated.

**GATE VALVES.**—Jenkins Brothers, 80 White street, New York, have recently issued a folder on the subject of Jenkins Brothers brass gate valves. This folder contains a number of illustrations showing the various forms and sizes of these valves, with reference numbers.

**KEWANEE UNION.**—A four page leaflet issued by the National Tube Company, Pittsburgh, Pa., is devoted to the male and female pattern Kewanee union. The leaflet states a number of the advantages claimed for this type of union, as well as other data concerning it.

**PORTABLE VOLTMETER.**—The General Electric Company, Schenectady, N. Y., has issued bulletin No. 46,018, describing this company's portable voltmeter known as type P-8. This is an unusually small instrument and is suitable for use on both alternating and direct currents.

**POWER HAMMERS.**—A pamphlet issued by Beaudry & Company, 141 Milk street, Boston, Mass., is descriptive of the Champion and Peerless power hammers manufactured by this company. The pamphlet contains illustrations of the hammers as well as tables giving the various sizes and dimensions.

**GAS-ELECTRIC MOTOR CARS.**—Bulletin No. 44,300 from the General Electric Company, Schenectady, N. Y., illustrates and describes some of the gas-electric motor cars and locomotives built by this company. These cars and locomotives are adapted to branch line service on steam roads and also for interurban service.

**SMALL MOTORS.**—The General Electric Company, Schenectady, N. Y., has just issued bulletin No. 41,500, describing the small direct and alternating current motors of the drawn shell type manufactured by this company. These are fractional horsepower motors which have been specially designed for diversified forms of small machines.

**ELECTRIC TRAIN OPERATION.**—Train operation for city, suburban and interurban service, is the subject of a booklet recently issued by the Westinghouse Electric & Manufacturing Company, East Pittsburgh, Pa. This includes illustrations of a large number of cars and trains which are equipped with Westinghouse electrical apparatus.

**BOILER TUBE CLEANERS.**—A four page leaflet issued by the William B. Pierce Company, 45 North Division street, Buffalo, N. Y., illustrates and describes the Dean boiler tube cleaner. A description of the method of operation is given and there is also included a drawing showing the use of the steam tube cleaner in brick arch supporting tubes.

**HEATING AND VENTILATING SYSTEM.**—A 16 page booklet, issued by the American Blower Company, Detroit, Mich., illustrates and describes the heating, ventilating and cooling system of the Sirocco type installed in the plant of the Ford Motor Company, Detroit, Mich. A page is also devoted to the various types of blowers manufactured by this company.

**COALING STATIONS.**—A four page pamphlet issued by the Roberts & Schaefer Company, Chicago, deals with the Holmen coaling plant. A halftone illustration is included showing the coaling station recently erected at the clearing yard of the Chi-

cago & Western Indiana near Chicago, and a number of other illustrations and reproductions from drawings are also included.

**VALVES.**—A pamphlet recently issued by the Golden-Anderson Valve Specialty Company, Fulton building, Pittsburgh, Pa., illustrates a number of different types of valves manufactured by this company. These include double cushion, triple acting, non-return valves; quick closing stop valves; combined throttle and automatic engine stop valves and automatic water service valves.

**ALTERNATING CURRENT GENERATORS.**—Bulletin No. 40,500 from the General Electric Company, Schenectady, N. Y., is devoted to the subject of alternating current generators for direct connection to reciprocating engines. This bulletin illustrates and describes some of the recent improvements in the alternators built by this company for direct connection to steam, oil and gas engines.

**AXLE LIGHTING EQUIPMENT.**—The Safety Car Heating & Lighting Company, 2 Rector street, New York, has issued a catalog bearing the date of October, 1914, on the operation of Safety axle driven car lighting equipment. This catalog contains 35 pages and illustrates in detail the Safety axle driven system. It also includes instructions pertaining to the operation of the equipment.

**COMMUTATING POLE RAILWAY MOTORS.**—Bulletin No. 44,404, issued by the General Electric Company, Schenectady, N. Y., describes ventilated commutating pole motors manufactured by this company. These motors have a rated capacity of 80 hp. on 600 volts, but because of induced ventilation, a greater service capacity than motors of the closed type having the same hourly rating is claimed for them.

**DYNAMOMETERS.**—Bulletin No. 48,701 superseding bulletin No. 112 from the Sprague Electric Works of the General Electric Company, 527 West Thirty-fourth street, New York, is devoted to the subject of Sprague Electric dynamometers. A large number of illustrations are included, as well as descriptive matter pertaining to the different types of equipment which may be tested by these dynamometers.

**HEAT TREATING FURNACES.**—Bulletin No. 6 from the Quigley Furnace & Foundry Company, Springfield, Mass., is devoted to overfired, accurate temperature, heat-treating furnaces using gas or oil as fuel. These furnaces are intended for economically heating and handling material, annealing, hardening, tempering, carbonizing, etc., where uniform and controllable temperature is required. The bulletin contains a number of illustrations.

**BOILER CIRCULATION.**—The Q & C Company, 90 West street, New York, has issued a catalog describing the Ross-Schofield system of circulation for locomotive boilers. This catalog is handsomely gotten up and is illustrated with photographs and colored engravings. The system has been installed on stationary boilers on the Philadelphia & Reading, as well as on locomotive boilers on that road and on the New York, Ontario & Western.

**ELECTRIC RAILWAY APPARATUS.**—The General Electric Company, Schenectady, N. Y., has issued bulletin No. 44,003, devoted to modern electric railway apparatus. This bulletin is attractively gotten up and is thoroughly illustrated. It briefly describes the Curtis steam turbine for railway service, railway generators, transformers, switchboards, ventilated railway motors, electric locomotives, etc., and contains illustrations of the electric locomotives in use at the locks of the Panama Canal.

**SUBSTATION EQUIPMENT.**—Among the recent publications of the Westinghouse Electric & Manufacturing Company, East Pittsburgh, Pa., is circular No. 1,550, which is devoted to 1,500-volt direct current substation equipment. Descriptions are given of a number of electric railroads throughout the country which are using this type of equipment, several of which are well illustrated with maps and photographs.

















CARNEGIE LIBRARY OF PITTSBURGH



3 1812 04296 1178