

95
1/2

25





James Moffat 1826

908444

SYSTEM

OF

MINERALOGY,

COMPREHENDING

ORYCTOGNOSIE,
GEOGNOSIE,
MINERALOGICAL CHEMIS-
TRY,

|| MINERALOGICAL GEOGRA-
PHY, AND
|| ŒCONOMICAL MINERALO-
GY.

By ROBERT JAMESON,

REGIUS PROFESSOR OF NATURAL HISTORY AND KEEPER OF THE MUSEUM
IN THE UNIVERSITY OF EDINBURGH, FELLOW OF THE ROYAL AND
ANTIQUARIAN SOCIETIES OF EDINBURGH, OF THE LINNEAN
SOCIETY OF LONDON, HONORARY MEMBER OF THE ROYAL
IRISH ACADEMY, OF THE MINERALOGICAL AND
PHYSICAL SOCIETIES OF JENA, ETC.

VOL. I.

EDINBURGH:

PRINTED BY C. STEWART;
FOR ARCHIBALD CONSTABLE AND CO. EDINBURGH;
T. N. LONGMAN AND O. REES, LONDON.

1804.

1841

WELLINGTON



Handwritten notes:
Samm. 11. 3.
1890

S Y S T E M
OF
ORYCTOGNOSIE,

ACCORDING TO THE METHOD OF THE ILLUSTRIOUS
WERNER OF FREYBERG.

Wenn ich ein mineralogisches Lehrbuch, um daraus zu lernen, aufschlage, so thue ich es; entweder, um überhaupt eine Kenntniss von dieser Wissenschaft zu erlangen, oder, um insbesondere von einem fossile, das ich bloß dem Namen nach kenne, den vollständigen Begriff zu bekommen: oder von einem fossile, welches ich gefunden und an dem ich seine äußerlichen Kennzeichen aufgesucht habe, zu erfahren, wie es heiße und welchen Platz es in dem System der fossilien einnehme. Leistet mir hierinnen ein Lehrbuch größten theils genüge, so nenne ich es gut, und wenn es mich völlig befriediget, denn nenne ich es vollkommen.

Werner's Aufferlichen Kennzeichen, S. 13.

Digitized by the Internet Archive
in 2016

TO
COLONEL ALEXANDER DIROM,
OF MOUNT ANNAN,
QUARTER-MASTER GENERAL FOR SCOTLAND,
FELLOW OF THE ROYAL SOCIETY OF EDINBURGH, &c.

THIS SYSTEM OF ORYCTOGNOSIE

IS INSCRIBED,

IN TESTIMONY OF THE RESPECT AND GRATITUDE

OF HIS OBEDIENT, HUMBLE SERVANT,

ROBERT JAMESON.

COLLEGE OF EDINBURGH, }
APRIL 30, 1804. }

COLONIAL ALEXANDRIA MUSEUM

OF THE

EGYPTIAN GOVERNMENT

OF THE

EGYPTIAN GOVERNMENT

OF THE

EGYPTIAN GOVERNMENT

OF THE

EGYPTIAN GOVERNMENT





P R E F A C E.

I SHALL employ a few pages in giving a very short historical account of the authors who have treated of mineralogy, with the view of enabling the reader to appreciate more fully the merits of the Wernerian system, on which the present work is founded.

The mineralogical writings of Pliny, Theophrastus; and Dioscorides, have made us acquainted with the luxury of the Romans and Grecians, and their fine works of art; but they contain nothing of system, and very little of tolerable description. The first systematic mineralogist was undoubtedly the celebrated Saxon miner George Agricola. He was also the first who investigated the external characters of minerals, determined them with any degree of accuracy, and used them with judgment in the description of fossils. In his system he divides minerals into those which are composed of homogeneous parts, and those composed of heterogeneous parts. The homogeneous, or simple minerals, he subdivides into four classes, which are entitled, 1. Terra, 2. Succus con-

a cretus,

cretus, 3. Lapis, and 4. Metallum. The heterogeneous are divided into compound and mixed minerals.

Nearly at the same time the famous Cardan wrote a treatise on minerals, which differs principally from that of Agricola in the saline being separated from the inflammable bodies.

Kentman's work *De omni rerum Fossilium Genere, Gemmis, Lapidibus, Metallis, &c.* published in 1665, is nearly a transcript of Agricola de *Natura Fossilium*. He adds to it, however, a treatise on petrifications, entitled *Alcyonia, conchæ, et alia, quæ ex falso liquore maris et ex ejus spumæ, cum tenuissimis fordibus permixta concrefcunt.*

The justly celebrated botanist Cæsalpinus published, in 1602, a work entitled *De Rebus Metallicis*, which contains little deserving of notice.

In 1609 Bootius Von Boot published a treatise on precious stones, in which we find described upwards of six hundred varieties, having all particular names, a proof of the attention paid to minerals at that early period.

At this time the first Spanish mineralogist, Alonzo Barba, a Mexican priest, published his work *De los Metallos*. It contains descriptions, and methods of working minerals. He was the first who treated of amalgamation.

The great compiler Aldrovandus, in his *Museum Metallicum*, delivered a system of mineralogy extracted from the writings of Agricola, Cardan, and Cæsalpinus. He was the first who drew the attention of mineralogists

mineralogists to petrifications. In this path he was followed by Johnstone in his *Notitiæ Regni Mineralis*, published in 1667, and by the well known jesuit Athanasius Kircher, in his *Mundus Subterraneus*, published at Amsterdam in 1678.

Some years afterwards Woodward published his *Catalogue of Minerals*. He may be considered as the first English mineralogist of note.

Becher, in his *Physica Subterranea* published at Leipzig in 1708, endeavoured to arrange minerals according to their constituent parts. He was the first writer who proposed the opinion, that the difference in composition of earths and stones might be employed in their arrangement and discrimination. He also first introduced the division of metals into perfect and imperfect.

Bromel in his *Catalogus Generalis rerum curiosorum*, published at Gothenburg in 1698, retained the Becherian division of metals into perfect and imperfect, and arranged sulphur and bituminous bodies in the same class.

In the beginning and towards the middle of the eighteenth century Beyer *, Büttner †, and Scheuchzer ‡, employed themselves principally in the investigation of that highly interesting class of bodies, petrifications; although their works are disfigured by many

* *Oryktographia Norica*. Nuremb. 1758.

† *Mineralogia et Oryktographia Helvetiæ*. Zurich 1718. *Herbarium Diluvianum Ludg. Batav.* 1723. *Homo Diluvii testis*. Zurich 1726.

‡ *Buttner Ruderii Diluvii testes*.

foolish speculations, and the individual species are but indifferently ascertained, yet from this period the attention of mineralogists was more directed to the examination of great rock masses than had formerly been the case. In this point of view the labours of these enquirers must be considered as of importance.

In 1730, Magnus Von Bromel, a scholar of Hiærne and Boerhaave, published a system of mineralogy. He divides minerals into eight classes, 1. Earths, 2. Salts, 3. Sulphurs, 4. Stones. 5. Petrifications, 6. Calculi. 7. Semi-metals, and 8. Metals.

In 1739, Cramer published a system of mineralogy, which contains seven classes. 1. Metals, 2. Semi-metals, 3. Salts, 4. Inflammable substances, 5. Stones, 6. Earths. 7. Waters.

In 1736, the illustrious Linnæus published the first sketch of his mineral system. He divides minerals into three classes, 1. Petra, 2. Mineralia, 3. Fossilia. The first class contains three orders, *a.* Vitrescentes, *b.* Calcarix, *c.* Apyræ. The second three orders, *a.* Salia, *b.* Sulphuria, *c.* Mercurialia. The third class contains also three orders, 1. Concreta, 2. Petrifacæta, 3. Terræ.

This system is in many respects faulty, and its principal merit consists in having first drawn the attention of mineralogists to the study of the crystalline figures of minerals. Although Linnæus cannot be said to have contributed much to the progress of mineralogy, yet indirectly his labours in the other branches of natural history laid the foundation of that reformation which was afterwards effected by
Werner.

Werner. He was the first who established right ideas of system. He shewed that its principal object was to assist the memory, and to enable naturalists to distinguish bodies from one another, and thus to ascertain if what they were investigating had been previously described by others. He also taught that no system could be of use that did not possess an uniformity in the basis of its classification and nomenclature, and a fixed and generally received language.

Nearly at the same time mineralogical chemistry was much advanced by the labours of Pott and Henckel; but of these Pott possessed the most extensive and correct chemical knowledge. He arranged earthy minerals according to their proportion of ingredients, and thus paved the way for many of the chemical systems of the present day. His four classes are the alkaline, siliceous, argillaceous, and gypseous. Death prevented this most indefatigable chymist from extending his enquiries to the metals.

In 1747, Wallerius, professor of mineralogy at Upsal, and cotemporary with Linnæus, published a system of mineralogy. He divides all minerals into four classes, *viz.* 1. Terræ, 2. Lapidés. 3. Mineræ, 4. Concreta. The first class contains four orders, 1. Macræ, 2. Pingues, 3. Minerales, and 4. Arenaceæ. The second class is subdivided into four orders, 1. Calcarii, 2. Vitrescentes. 3. Apyri, and 4. Saxa. The third class is subdivided also into four orders, 1. Salia, 2. Sulphura, 3. Semimetalla, and 4. Metalla. The fourth class comprehends four orders, 1. Pori, 2. Petrifacta, 3. Figurata. 4. Calculi. In
this

this system the external characters of the species were more accurately detailed than had been done by any other mineralogist, the terminology was improved, and the synonyms of preceding authors were elucidated.

Woltersdorf, a scholar of Pott, soon after wrote a system of mineralogy, which, however, added nothing to what was then known.

In 1758, the celebrated Cronsted published a system of mineralogy*. It is divided into four classes, *viz.* 1. Terræ, 2. Salia. 3. Phlogistica, and 4. Metalla.

The first class contains nine orders, 1. Calcarea, 2. Silicea, 3. Granatina, 4. Argillacea, 5. Micacea, 6. Fluores, 7. Asbestina, 8. Zeolithica, and 9. Magnesia. The second class contains two orders, 1. Acida, 2. Alkalina. The third class contains but one order. The fourth has only two orders, 1. Perfecta, 2. Semimetalla. One of the most striking excellencies of this system is the strict adherence to a fixed principle as the basis of classification; it is throughout chemical, and the principles on which the orders and genera are founded are still pretty generally followed by chemical mineralogists.

The compound rocks and petrefactions which had been included in the mineral (oryctognostic) system, by Linnæus and others, were very judiciously described in an appendix by Cronstedt. The descriptions of the species, however, were, from want of at-

* Systema Minerale, Berolini, 1748, 8vo.

tion to the external characters, extremely imperfect, yet, as it was not so much Cronsted's intention to write an oryctognostic system as one of chemical mineralogy, this defect must not be supposed to detract from the merit of his work.

To Cronstedt succeeded Lehman and Vogel, but their oryctognostic labours were of little importance.

In 1768, Linnæus published a second edition of his *Systema Mineralogicum*. In it the classes are the same with those of the first edition, but the number of orders and genera is increased. He prefixed to it an account of the external characters which he employed in the description of minerals. Respecting his system of characters, Werner observes, "Nur ist die ordnung, wen man es anders noch eine nennen kann, in der er sie aufführt, nicht zu loben: zudem sind solche nicht vollständig abgehandelt, indem noch gar viele fehlen; auch sind die mehresten erklärungen zu kurz, und deswegen dunkel und unverständlich; und endlich so fehlen erläuterungen durch beispiele, welche doch zum verständlichkeit der beschreibungen sehr vieles beitragen."—*Werner*, f. 48.

Peithner, in 1778 published tables of the external characters of minerals*; and Sir John Hill, in 1772, published a system of mineralogy, accompanied with tables of the external characters, resembling those of Peithner, but more extensive and determinate*.

* Joh. Thad. Peithners, erste grunde der Bergwerks wissenschaften. Zweite abhandlung uber die mineralogie. Prag. 1770. 8vo.

Wallerius, in the new edition of his *Systema Mineralogicum*, published at Stockholm in 1772, was the first who subjected to a serious examination the principles on which mineralogists had hitherto arranged minerals. He rejected the characters drawn from use, value, and geognostic situation, and affirmed, that classes, orders, and genera should be arranged according to chemical, but species principally in conformity with the external characters. These principles he employed in the construction of his system, which proved the most complete, and possessed the most determinate nomenclature of any that had hitherto appeared. By thus combining with the chemical characters those external characters that were then known, he enabled mineralogists to discriminate minerals with more certainty than they had been hitherto able to do. Still, however, the want of a proper mineralogical language rendered all systems and descriptions imperfect, and comparatively useless. The external characters employed by Agricola, Linnæus, Wallerius, Hill, and others were either undefined, or so inaccurately explained that it was difficult to understand, or avoid confounding them with one another; besides, they were employed irregularly, and even frequently intermixed with chemical, physical, and empirical characters.

The illustrious Werner early saw the impossibility of mineralogy advancing steadily without a determi-

* Hill's fossils, arranged according to their various obvious characters, London, 1771, 8vo.

nate language, he therefore made this the first object of his attention, and published the result of his observations in his classical work, *Von den Kennzeichen der Fossilien*. This admirable treatise laid the foundation of true *oryctognosie*, I may even say of mineralogy. In it Werner has collected together all the old and known characters, described many which he himself discovered by comparing minerals together: accurately defined every character then known, gave to each an appropriate and fixed denomination, and arranged the whole in systematic order. Since the publication of this treatise, he has discovered several very important external characters, and has much improved the descriptions of many of those contained in his early work. The system of characters as now delivered by Werner may be placed with the *Philosophia Botanica* in its most finished state.

I should now proceed to mention the different *oryctognostic* publications, of the Wernerian school, but I shall for a short time interrupt the regularity of this view by giving a short account of the writings of two French mineralogists, whose labours have in France formed a kind of national mineralogy.

The first is the celebrated Romé d'Isle, who published an excellent work on crystallization in 1783. In it minerals are divided into three classes: the first contains saline crystals, the second stoney crystals, and the third metallic and semi-metallic crystals. He was the first, after Werner, who particularly directed the attention of mineralogists to the primitive form of

crystals, of which he enumerates the following species : — 1. Tetraedron. 2. Cube. 3. Octaedron. 4. Parallelepiped. 5. Rhomboidal octaedron, and 6. Dodecaedron, with triangular planes. He considered all minerals that agreed in crystallization, hardness, and specific gravity, as belonging to the same species.

The descriptions of the species were the most accurate and complete that had been delivered, and contributed more to the advancement of oryctognosie than the writings of all preceding mineralogists.

To him succeeded several other French mineralogists; of these the most remarkable and only one deserving of notice is the Abbé Hauy. This intelligent philosopher was long employed in crystallometrical researches, of which he gave an account in a treatise published some years ago. Since that period he has extended his investigations to the greater number of simple minerals; and in 1801 he published the result of his very laborious and ingenious observations and speculations in a work entitled *Traité de Mineralogie*. In it simple minerals are divided into four classes. The first comprehends the combinations of earths and alkalis with acids; it is subdivided into three orders. 1. Contains the combinations of earths with acids. 2. Combinations of alkalis with acids. 3. Combinations of earths with acids and alkalis.

The second class contains those earthy substances, into whose composition there sometimes enters a portion of alkali. This class has neither orders nor genera, but is only a series of species.

The third class comprehends the combustible substances, with the exception of the metals. It is subdivided into two orders. 1. Simple combustibles. 2. Compound combustibles.

The fourth class includes all the different metallic minerals. It is subdivided into three orders. 1. Contains metals not oxydable by heat. 2. Those which are reducible and oxydable by heat. 3. Metals which are oxydable, but not reducible by heat.

These four classes are followed by three appendices. In the first appendix is contained all doubtful or unascertained minerals. The second includes all the compound rocks. It is subdivided into three orders: the first contains primitive rocks; the second, the secondary and tertiary rocks; the third, aggregates formed by the agglutination of fragments.

The third appendix is dedicated to volcanic productions. It is subdivided into six classes. 1. Contains lavas. 2. Thermantides. 3. Products of sublimation. 4. Altered lavas. 5. Volcanic tufas, and 6. Substances which have been formed in lava after their eruption, and cooling.

In this system the arrangement of simple minerals is almost strictly chemical; but the arrangement and description of the rocks and lavas is founded on certain fanciful ideas respecting their formation, and is extremely ill executed; but an examination of this part of the system of Hauy belongs properly to geognosie.

The species of simple minerals is determined from one character, which is styled the integral molecule. Hauy defines the mineral species to be “ Une col-
 b 2 “ lection

“ lection des corps dont les molleculles integrantes
 “ sont semblables, et composés des memes elements
 “ unie en memie proportion.” This integral molle-
 cule or kernel is detected, either by mechanical di-
 vision, or by measurement combined with calcula-
 tion; and when found, is asserted to afford an in-
 variable essential character for the species. I cannot,
 however, subscribe to this opinion; on the contrary,
 I venture to affirm, that it is not, in any instance, the
 type of the species, and that it only makes us ac-
 quainted with peculiarities in the structure of a few
 crystallized minerals, peculiarities which may indeed
 be afterwards discovered in other specifically distinct
 minerals. That it affords no essential characters is
 evident, because different species, as diamond and
 spinelle have the same integral molleculle; and other
 minerals, as zeolite, that unquestionably belong to
 the same species, have different integral molle-
 cules. That it makes us acquainted with peculi-
 arities in the structure of but a few crystallized
 minerals is shewn, 1. From the impossibility of de-
 tecting the integral molleculle by calculation com-
 bined with measurement, therefore all the species as-
 certained by this method are to be expunged from
 the system*. 2. From many species having the same
 integral molleculle; and individuals of the same spe-
 cies having different molleculles. Thus it appears
 that its existence as a peculiarity, remains but to a few
 species.

* Patrin. Dict. Hist. Nat.

That even this peculiarity, which we find in a very few crystallized minerals may be discovered in others specifically different, is proved from the case of diamond, spinelle, &c.*

It appears from this that the integral molecule cannot in any instance be considered as the type of the species, therefore, the oryctognostic system of Hauy, which is built on this supposition, must fall to the ground †.

The various attempts that have been made to describe and to discriminate the mineral species by a

* The instances of the inconsistencies that occur in the employment of the integral molecule are numerous, but of these I shall only mention one. Zeolite is one of the most natural and best ascertained species in the system, and its subspecies are connected together by agreements in oryctognostic and geognostic characters. Hauy having, however, found small differences in the integral molecules of these subspecies, has divided it into four species. Spinelle and diamond are acknowledged by Hauy to have similar integral molecules, yet he considers them as distinct species, and distinguishes them from one another by hardness and other external characters. Thus in one instance we find the integral molecule assumed as of superior characteristic importance to all the other external and geognostic characters combined; but in the other it yields even to a few of the other external characters.

† Independent of the objections stated above, there is still another, and probably a more forcible one to be opposed to the system of Hauy; it is that the greater number of minerals are not crystallized, consequently, according to the definition of Hauy, have no discoverable integral molecule, therefore are not species. Hauy indeed suspects that they are not species!!!

few characters, as by the primitive form, integral molecule, or the primitive form* combined with hardness and specific gravity have all proved insufficient. Werner was early aware of the insufficiency of such methods, and in his work on the external characters, published in 1774, he gave the first examples of the true method of describing species. In these descriptions all the characters presented by the *species suite* are detailed with a certain degree of minuteness, and in a determinate order, so that we have a complete picture of it, and are furnished with characters that distinguish it from all known species, and from every mineral that may hereafter be discovered.

In 1780 he published the first part of a translation of Cronstedt's mineralogy. It was in his annotations

* In amorphous minerals, the species are determined from the colour, shape, surface, lustre, fracture, distinct concretions, hardness, transparency, and specific gravity; each species presents a peculiar *suite* of characters, that characterize and distinguish it from all others. Also in crystallized minerals the character of the species is to be taken from the crystallizations, combined with the other characters. If, on the contrary, we would attempt to describe the species from one or a few characters, we will undoubtedly confound species that are different, and subdivide those that are similar. This renders the use of the primitive form nearly equally objectionable with the integrant molecule. We cannot too often bring to our recollection, that every mineral species is to be determined from the aggregate of all the characters, combined with the geognostic relations; a mode of investigation, which, independent of the certainty it gives to our determination of the species, prepares us for the higher study of geognosie.

on this work that he gave the first sketch of his oryctognostic system, and published many descriptions in conformity with the method laid down in his treatise on the external characters. In this system we find earthy minerals (for this was the only part of the system then published) divided into four genera, viz. siliceous, argillaceous, talcaceous, and calcareous; and these genera subdivided into species, subspecies and kinds. The species, as already mentioned, are not described by a few, but by all the external characters.

In 1791, he published a catalogue of the great mineral collection of the then deceased Pabst Von Ohaine, captain general of the Saxon mines. In this interesting work we have a tabular view of the whole oryctognostic system, in which the method of genus, species, subspecies, and kind is continued; several additions are made to the external characters, and the arrangement of the species is in some instances changed, owing to the examination of more complete mineral suites.

Since that period his oryctognostic publications have been confined to a few, but very masterly memoirs, in the miner's journal, so that we have still to regret the want of his own exposition of his oryctognostic system. His numerous pupils, however, have made it known in every civilized country of Europe. In Germany it has been published by Widenman, Emmerling, Karsten, Estner, Reufs, and Lens; in Spain, De La Rio has published an account of the system of his great master; Napione has done the same in Italy; in Sweden and Denmark it is also followed

lowed and taught ; it has been introduced into France by an able mineralogist M. Brochant ; and Kirwan, one of the most illustrious of British philosophers was the first who made it known in England *. Several

* In 1800 Brunner published a treatise entitled Versuch eines Newen Systems der Mineralogie, &c.

It is founded solely on the external characters. It is divided as usual into four classes, *viz.* earthy, saline, inflammable, and metallic. The first class is subdivided into seven orders: the first order contains all earthy minerals which "have an earthy fracture, and are dull and opaque." 2d, Having a fine scaly fracture. 3d, Having a foliated fracture. 4th, Having a radiated fracture. 5th, Fibrous fracture. 6th, Fine grained foliated fracture. 7th, Distinct compact fracture. The second class contains eight orders: 1st, Having a fourish astringent taste. 2d, Sweetish astringent taste. 3d, A rather disagreeable saltish cooling taste. 4th, Pure saline taste. 5th, Pungent saline cooling taste. 6th, Bitter taste. 7th, Weak soapy taste. 8th, Sharp alkaline taste. The third class contains three orders: 1st, Bituminous. 2d, Coaly. 3d, Sooty. The fourth class is subdivided into eight orders: 1st, Earthy fracture, dull, or faintly glimmering. 2d, Compact fracture, common, frequently a little metallic, lustre. 3d, Common lustre, and foliated fracture. 4th, Common lustre and radiated fracture. 5th, Common lustre and fibrous fracture. 6th, Metallic lustre and in loose scales. 7th, Metallic lustre and fluid. 8th, Metallic lustre and solid.

In his system the most dissimilar minerals are associated together; those that evidently belong to the same natural family are separated; and in no instance is there such a description of the species given as to enable us to distinguish them from one another. To exemplify this we may mention, 1st, That wood tin, fibrous malachite, red ore of antimony, cobalt bloom, and feather-rose antimony, are placed in the same order. 2d, Mica, selenite, potstone, hornblende, feldspar, diamond spar, calc spar, heavy, spar

Several of the works I have now mentioned were published when the Wernerian oryctognosie was far removed from its present state of perfection; and are consequently in many respects imperfect. The mineralogy of the intelligent M. Brochant, which may be considered the best account of the Wernerian oryctognostic system hitherto published, is unsatisfactory.

In the work I am now to lay before the public, I shall, in the two first volumes, deliver a system of oryctognosie, in which I shall follow the arrangement and method of description of Werner, and when I venture to deviate from the system of my illustrious master, I hope to be able to assign satisfactory reasons for the alterations I may propose*.

The task which I have undertaken was to have been executed by my ever to be regretted friend, Dr Mitchell, whose long experience and consummate skill eminently qualified him for it. Unfortunately

spar are arranged together; and 3d, Of columnar heavy spar we have the following description: "Usually of bright white colour: Lustre pearly: Either translucent or translucent on the edges: Soft; and its crystals are aggregated into columns:" This is another striking instance of the insufficiency of all methods that do not embrace in the account of the species all its external characters, and in the arrangement the natural alliances.

* Some of the names and expressions which will occur during the course of this volume, and which may by some be difficultly understood, will be fully explained in the treatise on the External Characters, which will accompany the second volume, and in the volume on Geognosie. I trust therefore that the language which I have employed will not be criticised with severity, until I have an opportunity of explaining it.

for mineralogy this accomplished and most amiable man was removed from this transient scene before he was permitted to communicate to the world the results of his own profound observations and thoughts, on a science in the knowledge of which he was only rivalled by its great founder Werner.

Previous to entering on the description of the individual minerals, I shall, in the Introduction, first state the basis on which this system is founded; then mention the method followed in subdividing it into classes, genera, species, and subspecies, and give an account of the different characters employed in mineralogy, of the rules of mineralogical nomenclature; and, lastly, shew the utility of oryctognosie and the requisites necessary to form an oryctognost.

INTRODUCTION.

MINERALOGY is that branch of natural history * Definition of mineralogy. which makes us acquainted with all the properties and relations of minerals. As these properties and relations are very different from each other, we cannot

C 2

cannot

* If it be true "that description, when employed about events, constitutes history," then certainly the usual appellation, Natural History, is erroneous. That relation which aspires to the dignity of history, must embrace not only an exact and full description of the object or thing treated of, but also ascertain the relative time as well as manner of its production, and the change and alteration, if any, it has undergone in arriving at its present state. Natural history therefore comprehends two distinct branches, the one making us acquainted with natural objects as they are presented by nature, furnishing us with sufficient data and easily applicable criteria to distinguish them from each other, and this is *Natural Description*. The other branch, Natural History properly so called, consists in the investigation of the ancient and original state of natural objects, and the successive changes and alterations they have undergone till the present time. Thus in botany and zoology the questions, Were all animals and plants originally created as we

at

cannot arrange them together without producing much confusion. On this account Werner found it necessary to consider them under five different heads, or what he terms mineralogical doctrines: these are, *Oryctognosie*, *Geognosie*, *Mineralogical Geography*, *Mineralogical Chemistry*, and *Oeconomical Mineralogy*.

Oryctognosie.

Oryctognosie.—Or what has been hitherto in Britain and France denominated mineralogy, is that branch of mineralogy which makes us acquainted with minerals in a natural order, under fixed denominations, and by well ascertained characters.

Geognosie.

*Geognosie**—teaches us the structure, relative position and mode of formation of the mineral masses of which the crust of the earth is composed †.

Mineralogical

at present find them, or have they by degrees assumed the specific forms they now possess? Are certain species become extinct? In what order and whither have they migrated? What change has climate produced? In mineralogy, at what period, during the formation of our earth, and under what circumstances has a peculiar species of mineral been produced? Has it remained unaltered, or has it undergone changes? All these questions are of historical import, and belong to this department. In such investigation consists the scientific prosecution of Natural History; the mere art of distinguishing natural objects from one another can scarcely be entitled to that appellation.

* By Geology, Werner understands idle and imaginary speculation respecting the formation of the earth.

† At first sight the solid mass of the earth appears to be a confused assemblage of rocky masses, piled on each other without order or regularity: to the superficial observer nature appears in the rude matter of the unorganic kingdom, to present us only with

Mineralogical Geography—describes, in geographic order, the particular rocks that occur in the earth's surface in different countries, and makes us acquainted with the different species of fossils that are contained in them, and the manner of their occurrence. It gives us

with a picture of chaos, where none of those admirable displays of skill and contrivance, which in the structure of animals and vegetables so powerfully excite our attention, and claim our admiration, are to be observed. It is not surprising that this unfavourable opinion should have long continued to be prevalent, when we consider the skill, judgment, and experience which are necessary for enabling us to combine all that variety of apparently unconnected relations which are observable in the internal structure of the earth. In ancient writers we find nothing on this important subject. The striking phenomena of volcanoes appear frequently to have excited wonder and astonishment, which they always substituted for investigation. After the revival of letters, when science had assumed a more favourable aspect, and mines came to be worked by freed men, the objects of the mineral kingdom excited a considerable share of attention, the numerous interesting phenomena, which daily presented themselves to the miner, were carefully remembered, and at length recorded by the celebrated miner Agricola. From that period until the time of Werner, mineralogists brought to light many individual, and a few general facts respecting the structure of the earth. Lehman first pointed out the great natural division of mountains into primitive and secondary; Cronstedt ascertained the age of several mineral repositories; Hamilton described the phenomena of volcanoes; Dolomieu made us acquainted with the structure of volcanic hills; Sauffure enlarged our knowledge of the variety of primitive rocks, and an excellent observer, our countryman Williams, made many excellent observations on the independent coal formation.

Notwithstanding

us a picture of the structure and composition of particular tracts, geognosie that of the whole globe.

Mineralo-
gical che-
mistry.

Mineralogical Chemistry—makes us acquainted with the quantity and quality of the constituent parts of minerals.

Oeconomi-
cal mine-
ralogy.

Oeconomical Mineralogy—teaches us the different uses of minerals.

This excellent subdivision of the science, first marked its true limits, and its vast extent, and pointed out a clear path for future mineralogists.

Notwithstanding the labours of these industrious observers, our knowledge of the internal structure of the earth was still very limited and confused. Although observations had been made in very distant countries, and similar rocks discovered in a variety of the most widely distant situations, yet no successful attempt had been made to generalize these appearances, so as to discover the general structure of the earth, and the mode of its formation. Sauffure made the attempt, but neither his information nor ability seem to have been equal to this great task. He was also unacquainted with many facts which would have assisted him, and his attention was too much occupied with particular and local appearances to effect what has been since so fully accomplished by the comprehensive mind of Werner.

This great geognost, after many years of the most arduous investigations, conducted with an accuracy and acuteness of which we have few examples, discovered the manner in which the crust of the earth is constructed. Having made this great discovery, he, after deep reflection, and in conformity with the strictest rules of induction, drew most interesting conclusions, as to the manner in which the solid mass of the earth may have been formed. It is that splendid specimen of investigation, the most perfect in its kind ever presented to the world, which I shall give an account of in the volume of this work which treats of Geognosie.

2. As oryctognosie is the ground-work of mineralogy, a knowledge of it must necessarily precede that of the other doctrines. This is the reason why it is to occupy the early part of this work. I must remark, however, that it is not purely oryctognostic, for I have added to the description of each mineral, its chemical characters, constituent parts, geognostic and geographic situations, and a few notices respecting its uses.

Oryctognosie the basis of mineralogy.

3. An arrangement to be correct should have but one object for its basis; for when several are assumed it fails completely in accomplishing its purpose: it is also indispensably necessary in arranging natural bodies, that none which fall within the bounds of the system be omitted. Many mineralogists, by assuming as the basis of their systems not only the natural alliances, but also the chemical composition, geographic situation, and œconomical uses of minerals, and by separating the volcanic from other oryctognostic products, have rendered their systems unstable and incomplete. The Wernerian oryctognostic system is framed in conformity with the strictest rules of classification; it is founded solely on the *natural alliances and differences observable among minerals*. But on what do these depend? Werner answers on the quality, quantity, and mode of combination of the constituent parts.

General rules of arrangement.

Basis of the Wernerian oryctognostic.

Karsten, Haüy, Brochant, and other mineralogists have objected to the Wernerian system, that it arranges minerals together which are completely different

Objections to it.

ferent

The objec-
tions an-
swered.

ferent in their internal composition; thus they remark sapphire is placed in the flint genus, although it has been found to contain ninety-eight per cent. of alumina; and opal in the clay genus, although ninety-eight parts of silica. This objection, however, is founded on a misconception of Werner's opinion. He does not pretend that his arrangement shall always correspond with the experiments of the chemist; for it is only when chemical results agree with the natural alliances of the mineral that he gives them a place in his system. In instances where the affinities of the mineral with those already in the system have not been made out, and we are still uncertain as to its true nature, it is a matter of indifference where we place it. If it has been analysed we may arrange it chemically, not however from a conviction that its place will thus be fixed, which cannot be done until we have, by the examination of a complete suite, combined with a knowledge of its geognostic relations, discovered whether or not its characters authorise the arrangement made by the chemist. If we were to allow the arrangement to be made according to the most improved chemistry of the present day, we should have very dissimilar minerals grouped together, and those which are nearly allied separated. In such a system garnet and thumerstone would be considered as the same species; chlorite would be arranged among the ores of iron, and we should have a transition suite beginning with pumice, and proceeding through pearlstone, pitchstone, clinkstone, felspar, talc,

Chemical
arrange-
ment of
minerals.

talc, lepidolite, to leuzite. It is evident, therefore, that a chemical oryctognosie, in so far as it stands in opposition to the natural alliances observable among minerals, must be rejected.

4. Having now stated the principle on which the Wernerian system is founded, I shall next detail the method which is followed in dividing the whole mass of simple minerals into *classes, genera, species, subspecies, and kinds*. Subdivision of the mineral system.

The Linnæan division of class, order, genus, and species, having been found insufficient for the arrangement of minerals, Werner, to remedy this inconvenience, formed two inferior subdivisions, which he denominated subspecies and kind. Linnæan divisions not sufficient.

The highest division is the *kingdom*. The second, or *Class*, is founded on what Werner terms the fundamental constituent parts. Of these there are four, *viz.* 1. Earthy, 2. Saline, 3. Inflammable, and 4. Metallic; and these form four great natural classes. Class.

The *Order* does not form one of the divisions of this system; therefore the next is the *Genus*, which is characterized by the predominating or characterizing earthy, saline, inflammable or metallic matter. Genus.

There are many instances, however, where this definition does not apply. We may mention opal, diamond, and sapphire. It would therefore be better to rest satisfied with a description, such as we shall afterwards give, of the external aspect of the genus, and only assume the idea of a predominating ingredient, as intimating what we are intitled to expect will afterwards Characters of the genus to be taken from its external aspect.

wards be the case when analysis becomes more perfect*.

The next division is the *species*, which although the most important of the whole, has been ill understood by mineralogists.

Species.

It would be inconsistent with the brevity of this Introduction to mention all the variety of opinions that have been proposed respecting mineral Species; it is sufficient to mention that Werner considers all those minerals that agree in external characters and internal composition as belonging to the same species †.

Variety.

The next subdivisions are subspecies, kind, and variety. *Varieties* are those differences which we observe in the individual external characters, as lustre, fracture, hardness, &c.

* In place of doubting of the accuracy of chemical analysis, or of examining whether or not the chemist was entitled to believe that the substances which his analysis gave him pre-existed in minerals, mineralogists called in question a truth which appears inseparable from the existence of natural history, *viz. that the external aspect is an expression of the internal composition, and is a criterion of it.* In short we may believe that every analysis, (not confirmed by synthesis), which does not agree with the natural alliances of minerals, is false.

† In the animal and vegetable kingdoms each plant and animal constitutes a whole, possesses a determinate form, each individual exhibits an essential difference, and is capable of definition. In the mineral kingdom each fossil cannot be considered as an individual, but merely as a part of that immense individual, the globe; hence it is evident that, accurately considered, there exists but one mineral species or individual, which is the *globe*.

A *species*

A *species* is composed of a greater or lesser number of varieties.

If in a species we meet with groups of varieties that can be well distinguished from each other, we must give them a particular appellation; Werner denominates them *subspecies*.

Subspecies.

To illustrate the manner of forming subspecies, we shall take an example from the class of metals; it is lead glance which contains two subspecies, *a*. Common lead glance. *b*. Compact lead glance.

Mode of forming subspecies illustrated.

The essential character of the species is as follows: Colour lead grey. Lustre metallic. Streak unchanged. Mild. Soft. Very heavy.

First Subspecies. Common lead glance

Has sometimes particular external shapes as reticulated, cellular, tubular, &c. It is often crystallised. Lustre almost always shining, sometimes splendid. Fracture more or less perfectly foliated, generally straight, often curved foliated, with a threefold cleavage; seldom radiated and usually short, broad, and scopiformly diverging radiated. Very easily frangible.

Second Subspecies. Compact lead glance.

Colour is lighter than the preceding subspecies. Occurs only massive and specular; has no particular external shape. Lustre only glimmering. Fracture even. Fragments indeterminately angular. Does not occur in distinct concretions. Has more tenacity than the preceding subspecies.

When an extensive species is undivided, it is not only difficult to fix the picture of it in the mind, but

Necessity
and utility
of forming
subspecies.

Difficulty of
forming
subspecies.

the determination of the individuals of which it is composed requires a degree of skill and experience that few can hope to possess. It is therefore of the greatest importance, when such a species occurs, to endeavour to separate the groups of characters from each other, and place them in the system as subspecies. It must not be concealed, however, that such an operation requires much acuteness, and a most complete practical acquaintance with oryctognosie. In the writings of several German mineralogists we meet with many new subspecies; these are, however, vague indefinite things, that shew how little the framers of them have understood the Wernerian method.

Family.

The term Family, used in this work, intimates that all the minerals included under it belong to a natural family.

4. All the differences mentioned in the preceding section must be arranged in a determinate order, and in such a one as shall correspond with the natural alliances of minerals. However easy this may at first sight appear, we must confess that the greater number of attempts have proved inefficient. The idea of a chain of nature, which was employed by zoologists and botanists, was here adopted as the basis of many arrangements, but no such chain exists; for, if it did, every species could only pass into the one preceding and following it, but this is not the case, for one species often passes into several, and others not into any, but stand isolated.

No chain of
nature.

The scheme in plate 11. shews the incompatibility of a natural chain, where every link fits correctly into each

each other, with the transitions of minerals. It represents the alliances of silver with gold, antimony, arsenic, silver, copper, iron, tin, lead, sylvan, and mercury.

In the following section I shall detail the method which is followed in the arrangement of these differences, or classes, genera, species, subspecies, and kinds.

5. In the arrangement of the members of the system, we first begin with the most general, and proceed to the more special. Secondly arrange them as much as possible in a natural order; and thirdly, in the higher division, as in the genera and species, we place the characteristic ones first, and allow the other less characteristic to follow in the order of their affinity; but when suites occur that do not possess such affinities, we place the characteristic member in the middle, and arrange the others on both sides according as they approach more or less to it. We shall now illustrate this method by giving an account of the arrangement of the different members of the system.

Rules to be followed in the arrangement of the members of the system.

6. The class of *earthy minerals* is distinguished from the others by its being in general not remarkably heavy, brittle, possessing usually white or light colours; being much disposed to crystallize, uninflam- mable in a low temperature, and insipid and inodorous. It is placed first in the system by reason of its simplicity, its constituting the greater part of the crust of the earth, and its being the repository of the minerals of the other classes.

Characters of class of earthy minerals.

Character
of saline
minerals.

The class of *saline minerals* is characterized by being moderately heavy, soft, possessing some degree of transparency, being chiefly white and sapid. It is placed immediately after the preceding class, by reason of its resemblance to it in several properties.

Character
of inflam-
mable class.

The *inflammable class*, which occupies the third place, is light, brittle, mostly opaque, always yellow, brown, or black, scarcely ever crystallized, does not feel cold, and as far as our present experience extends, it appears to be more nearly allied to the metallic than the earthy class.

Character
of the me-
tallic class.

The *metallic class* is heavy, chiefly opaque; in general possesses a peculiar lustre, is tough, often possesses some degree of malleability, exhibits a great variety of colours; is cold, and not easily inflamed. It is placed at the extremity of the system, because it is furthest removed, in properties, from the earthy class, and is nearly allied to the inflammable class.

Arrange-
ment of the
genera.

7. In a natural arrangement, as we have already mentioned, that genus, which possesses the characters of the class the most distinctly and completely, should be placed first, and the others should follow according to their greater or less affinity with it. In the class of earthy minerals or stones, the flint genus* possesses

* In the class of earthy minerals, there are six genera to which I have ventured to give the following denominations, 1. Flint genus. 2. Clay genus. 3. Talc genus. 4. Calc genus. 5. Baryte genus, and 6. Strontiane genus. The usual names, Siliceous genus, Argillaceous genus, &c. intimate, that
the

possesses those properties and characters that entitle it to the first place. To the flint succeeds the clay genus, because of its greater affinity to the flint genus than any other, and it passes by a natural gradation into the next, following the talc genus. The transition of these genera into each other is very complete, but the following genera, calc, baryte and strontiane, do not afford so beautiful a continuance of the series.

Besides these genera there is another that cannot be placed between any of those that are here mentioned without interrupting the natural order, it is the zircon. This genus in its external characters has much resemblance to the flint genus, but as it cannot follow, it must precede it, hence it is placed immediately be-

Arrangement of the earthy genera.

Why zircon is placed before flint genus.

the minerals comprehended under them contain a preponderating quantity of the earth which gives name to the genus. This, however, is not the case with the species as arranged in this work, for some belong to the flint genus that contain no silica, and others to the clay genus that contain no alumina. I have therefore judged it more consistent with the arrangement to adopt terms that express, not any chemical composition, but have a reference to the most striking and characteristic external characters of the genus, or to that species around which all the others belonging to the same genus, may by transition be arranged. Thus all the species belonging to the flint genus possess in an eminent degree the properties that in common life are termed flinty, and besides can be arranged around quartz or flint as a central point. In a similar manner all the fossils arranged under the talc genus are connected with the species talc by external characters and transition. I have preferred the terms talc and calc to talceous and calcareous, to preserve a uniformity in the nomenclature.

fore the flint genus. But zircon is not the only example; there is still another, which is the diamond; it must also have a place near the zircon, but on what pretence can an inflammable substance have a place here? The diamond was by the ancients placed among earthy minerals, but in latter times it has been discovered to be a combustible body, nearly pure carbon; hence chemists have very properly arranged it with inflammable bodies. Many oryctognosts have adopted the same arrangement; but Werner, for the following reasons, still continues to consider it as the most perfect of minerals, and as deserving to hold its place at the head of the mineral kingdom. 1. It agrees in many of its external characters with zircon, therefore it must be placed near it, and not to interrupt the arrangement before it. 2. When compared with other inflammable minerals it presents many striking differences; thus inflammable minerals are light, soft, generally dark coloured, easily inflamed, and not crystallized; on the contrary, the colours of the diamond are very numerous, it is almost always regularly crystallized, has considerable specific gravity, and of all minerals possesses the greatest degree of hardness.

Why diamond is placed at the head of the mineral system.

Saline genera.

The saline class contains but one genus, Werner, however, has divided it into four, viz. 1. Carbonate. 2. Muriats. 3. Nitrats, and 4. Sulphats*.

* This method is probably objectionable, and therefore is not followed in this work.

The genera of the inflammable class are, 1. Sulphur. 2. Coal, and 3. Graphite; and require no particular arrangement. Inflammable genera.

The metallic class, which is the next in importance after the earthy, contains a number of genera, which are arranged after the same method as the earthy genera, viz. those which possess the properties of the class in the highest degree are placed first. Metallic genera.

As platina possesses the metallic qualities in the highest degree, it is placed at the head of the class of metals. Next is gold, which agrees with platina in oryctognostic and geognostic characters. Mercury follows gold on account of its great specific gravity and strong lustre. Silver is the next genus; from it we have a natural transition to the next genus, copper. To copper succeeds iron, lead, tin, bismuth, zinc, antimony, cobalt, nickel, manganese, molybdæna, arsenic, scheele, menacane, uran, sylvan.

8. Having finished what was necessary to be said respecting the arrangement of the genera, I shall now illustrate, by an example drawn from the system, the mode of arranging the species. The example is from the flint genus. If the method which was employed in the arrangement of the genera be followed here, quartz, as the most characteristic species, should occupy the first place in the genus. Here, however, we find a whole series of species that cannot together be placed before or after quartz; the series must therefore be divided, quartz placed in the middle, and the other species so arranged that the first division shall precede, and the other follow quartz. Arrangement of species.

e

this

this method we are enabled to place all the species in a natural order, and obtain on the one hand a transition into the zircon genus, and on the other into the clay genus.

In the metallic genera, those species which are in the metallic state are placed first, next the different oxyds and combinations. Great attention must, however, be paid to the transitions, and their arrangements.

Arrange-
ment of
subspecies.

9. As the subspecies are few, their arrangement is comparatively easier; we must here attend, chiefly, to the rules of transition, so that the arrangement may be natural.

Characters
of minerals.

10. The characters which are employed in the description of minerals are, by Werner, divided into five classes, 1. External. 2. Chemical. 3. Physical. 4. Geognostic, and 5. Geographic.

1. *External Characters*—are those which are discoverable by the external senses, without inducing any considerable alteration in the aggregation of the mineral; thus colour, shape, lustre, fracture, hardness, weight, &c. are of this kind.

2. *Chemical Characters*—are those which are afforded by the complete analysis of the mineral; by trials with acids, with the blow pipe, and Wedgwood's pyrometer.

3. *Physical Characters*—are those physical properties of minerals which are discovered by trials with the magnet, or by rubbing or heating.

4. *Geognostic Characters*—The determinate occurrence of one mineral with another affords, what Werner

ner terms the geognostic character. I shall mention a few instances. Glance cobalt has so striking a resemblance to arsenical pyrites that it is often confounded with it; it however occurs along with copper-nickel, which is never the case with arsenical pyrites; this then is the geognostic character which ascertains it to be glance cobalt. Native arsenic frequently occurs along with red orpiment, but it never accompanies red lead ore; this, therefore, serves as an excellent character for distinguishing these two minerals, in doubtful cases.

5. *Geographic Character*—is determined from the birth place or local situation of a mineral. Thus if we are presented with a cochineal red coloured mineral from Joangeorgenstadt, its birth place or geographic character announces it to be red silver ore: if the mineral be from Landsberg or Idria, we would consider it as cinnabar; was it from the Hungarian mines, or those among the Uralian mountains, we would reckon it red copper ore.

The geographic character must, however, be confined within very narrow limits, as we know that the occurrence of minerals is seldom confined to particular spots or countries, and we are often uncertain if the specimens we have are from the places mentioned.

The geognostic character, on the contrary, is highly characteristic, and it is to be regretted that it has been hitherto so little attended to.

It has been much disputed which of the preceding kinds of character are best suited for the description and discrimination of minerals. It was long the prevailing

External characters sufficient for the arrangement and description of minerals.

vailing opinion, that external characters alone were sufficient; the increasing taste for chemistry introduced the chemical characters, and these in their turn have been adopted by several mineralogists, to nearly the exclusion of all the others. Werner teaches, that all the different kinds of characters are to be employed, but of these, he considers the external characters as by far the most certain and generally applicable. These characters are not only sufficient for the description, but also for the arrangement of minerals. That they are sufficient for the discrimination of minerals is certain, from the observation of Werner, who declares, that no mineral has ever been discovered which could not be distinguished by its external characters, and that they are sufficient for its arrangement is equally evident from the greater number of species in the mineral system being arranged solely by agreements and differences in the external characters.

As a knowledge of these external characters is absolutely required of every one who shall venture on the study of oryctognosie, I should now proceed to give an account of them, I must, however, from the great extent of the subject defer this for the present; but shall give a full explanation of them in the following volume.

11. In writing the description of a mineral, according to its external characters, Werner recommends

a. That it should contain all the external characters.

The external characters are not of equal importance; hence several mineralogists have judged it necessary, in their descriptions, to employ only the more characteristic

Method of
describing
a mineral.

teristic or essential ones. In some instances this may be done, but in the greater number of cases, the omission of any of the characters would lead to error. We must, therefore, in our descriptions, not only mention all the characters, but every branch of them, as far as they are characteristic of the species.

b. That we should place all the characters together.—The older, and many of the modern writers in mineralogy, by endeavouring to follow the methods of the zoologist and botanist, have rendered their descriptions of minerals unintelligible. To obtain an acquaintance with the external aspect of a mineral from such a description, or rather series of definitions, we must combine the characters of the class, order, genus and species, and after this labour, what do we obtain but a delusive and imperfect picture?

c. That these characters should not have any of the others intermixed.—As the description of a mineral according to its external characters is principally intended to give us a distinct picture of its aspect, and of certain physical properties it possesses, we must be careful that it contains nothing foreign to that object; it must, therefore, contain no chemical, geognostic, or geographic characters.

d. That they should be arranged in a determinate order.—When the characters are arranged in a determinate order, we are not so liable to omit any of them, and are enabled more easily to recollect the picture of the mineral. Werner arranges them in that order in which they naturally present themselves to our senses; thus beginning with colour, as that
which

which first attracts our notice, and placing the others in their corresponding places, viz. figure, lustre, fracture, fragments, distinct concretions, frangibility, brittleness and weight

e. That they should be sufficiently accurately determined.—Many minerals are completely alike, excepting in certain shades of character, which must also be mentioned if we do not wish to be deprived of the distinctions they afford. Thus it is not enough in describing white silver ore, to say that it has a grey colour, nor even that it possesses a lead grey colour; accurate determination requires that the colour of white silver ore should be given—fallow lead grey.

f. That it should contain only such expressions as have met with universal approbation.

g. That the degree of the frequency of the occurrence of any one of these characters should be expressed, as by the following terms, abundantly, commonly, sometimes, partly, seldom, rarely, very rarely.

h. That the description should be written so as to afford a synoptical view, and that the characters may easily attract the eye This is best done by beginning each character by a new line, and distinguishing the most important ones by capital letters, or, by printing in italics. My knowledge of oryctognosie is too limited to permit me the use of italics.

Werner's
method of
describing
a mineral.

In describing a mineral, according to the method of Werner, we do not employ a few isolated characters, as is done in zoology and botany, but, as I have already mentioned, a series or suite, which being peculiar to the species, consequently characterises it.

But

But such a picture or description is to be drawn up from the examination, not of one or a few, but from many specimens, hence the necessity of having an extensive mineral suite, before we pretend to know the species already in the system, or to describe new ones.

12. The only sources from which the denominations of minerals ought to be taken, are the following :

Sources from whence the names of minerals should be taken.

α. From some characteristic external character. Thus the mineral which chemists term sulphat of strontian is, on account of its characteristic blue colour, denominated by Werner Celestine. Actynolite derives its name from its radiated fracture; Schallstone, from its lamellar distinct concretions.

β. From resemblance to other bodies. Thus that remarkable mineral which was first found in Hungary and described by Fichtel as a species of zeolite, was, by Werner, denominated pearlstone, on account of its striking resemblance in colour, shape, and structure to pearl.

γ. From their use. As procelain earth from its use in the manufacture of procelain.

δ. From the place where first found. Thus Lydian stone derives its name from Lydia in Asia, where it was first found.

ε. From the name of the discoverer. Thus the mineral denominated by chemists carbonate of barytes, is named by Werner Witherite, in honour of its first discoverer, Dr Withering.

We

We must be very careful that the name conveys no false meaning, as is the case with black lead and others.

Minerals have often been named from their peculiar chemical properties or their constituent parts; but this is in general not to be recommended, as it renders the system of names fluctuating by reason of the daily alteration in preceding chemical analyses.

Chemical nomenclature not to be admitted.

Werner has, except in a few instances, very properly banished the chemical nomenclature from oryctognosie. In oryctognosie, as in zoology and botany, the nomenclature should be founded on some striking external character, or when that does not readily occur, the name should be arbitrary, derived from the name of the country where first found, that of the discoverer, &c.

Synonyms.

13. From the great confusion which reigned in mineralogy before the time of Werner, the ascertaining the synonymes of preceding authors is often attended with much difficulty, and indeed in few instances can be completely satisfactory. I have therefore been sparing of such synonymes. In later writers they are more easily and satisfactorily ascertained, and those I have frequently noticed and have arranged in chronologic order*.

Uses of oryctognosie.

As Oryctognosie is the rudiments of Geognosie, a knowledge of it is absolutely required of the *geognost*. It makes him acquainted with the individual

* The synonymes I have quoted only refer to authors who have given descriptions of minerals.

minerals of which the great mass of the earth is composed, with their various relations to each other, and thus paves the way for the investigation of the structure and numerous relations of those greater masses of which the crust of the globe is constructed. To the geognost.

To the *metallurgist* it affords the sure means of separating the different ores, and thus prevents the numerous errors in the processes of smelting, which are so often committed by mixing with the pure ore different foreign and pernicious ores and fossils. To the metallurgist.

The *miner*, by an acquaintance with *oryctognosie*, is enabled to distinguish the various minerals he meets with in his subterraneous workings from one another, and to regulate economically the labours of the separating house, and the various operations of stamping and washing. To the miner.

The *mineralogical chemist* cannot make us acquainted with the minerals which he has analysed, or know those he is about to subject to his operations, without a thorough knowledge of this branch of mineralogy. Its language will also enable him to describe his products and educts according to their colour, form, consistence, texture, &c. which, although but little attended to, is unquestionably of the greatest importance. We have only to read the descriptions of chemical products that are usually given to be convinced of the looseness of the language employed, and the necessity of introducing into chemistry the descriptive language of *oryctognosie*. To the mineralogical chemist.

To those who occupy themselves with the determination, value, and uses of gems, ores, limestones, To the economist
f
coals,

coals, building stones, saline substances, &c. oryctognostic knowledge is absolutely necessary; without it they will be exposed to perpetual losses and disappointments.

To the
man of
liberal edu-
cation,

To the man of liberal education it will afford much instruction and pleasure. It will give him a very great degree of accuracy in the determination of the external aspects of bodies, whether natural or artificial, and this precision he will carry into the other objects of his enquiries. Besides this, by becoming acquainted with the materials of which the earth is composed, he will naturally be led to continue his researches in order to become acquainted with those more extensive relations of minerals which are made known to us by that sublime branch of mineralogy *Geognosie*.

Qualifica-
tions requir-
ed of an
oryctog-
nost.

15. To be entitled, however, to the character of an oryctognost, that empyrical knowledge which we so often meet with will not suffice. To merit such a name we must be fully acquainted with all the external characters, with the manner of employing them; we must have a readiness in knowing and a precision in discriminating minerals; we must be able easily to refer known minerals to their place in the system, and when new species or subspecies occur, we must be able to give them their proper place in a natural arrangement, and to arrange the transitions in such a manner that the mineral species or subspecies may participate of the characters of the preceding and the following members of the system. We must from well chosen specimens be able to determine the nature

ture

ture of their repositories, and among the mountains must be able to do the same. We must know the chemical properties and composition of minerals, and all their variety of œconomical uses, and must know how to make, arrange, and describe collections, and must be well acquainted with the history of the individual species, and with that of oryctognosie in general.

Notwithstanding the long experience and minute attention which are required to form an accomplished oryctognost, in some countries mineralogy has been hitherto considered as merely a trifling branch of the science of medicine, or of political œconomy, or classed perhaps with the art of mending a dull fire, which every person conceives he understands, whether he has given himself the trouble of learning it or not. The time, however, we trust, is not far distant, when such pretences to science, the banes of true knowledge, will sink into merited contempt, and when mineralogy will be esteemed worthy of being regularly studied as one of the most useful and interesting branches of human knowledge.

In some countries mineralogy viewed as an insignificant and easily acquired branch of knowledge,

BOOKS QUOTED

IN THIS

W O R K.

Titles of Books.

Abbreviations under which they are designated.

Systema Mineralogicum, } *Wall.*
Wallerius, 1778.

Systema Naturæ, Linnæus, } *Lin.*
1768.

Christallographie, ou Description des Formes Propres a tous les Corps du Regne Mineral par M. de RomédeLisle, 1783. 4 tom. } *Rome d. L.*

Theophrastus's History of Stones, with an English version, and notes, by Sir John Hill, 1774. } *Hill Theoph.*

Catalogue

Titles of Books.

Abbreviations under which they are designated.

Catalogue Methodique et
Raisonné de la Collection
des Fossiles, de Mademoi-
selle Eleonore de Raab,
Vienne, 1790.

Born.

Wiedenman's Mineralogie.

Wid.

Elements of Mineralogy, by
Richard Kirwan, Esq.
1794 and 1796.

Kirw.

Lehrbuch der Mineralogie
Entworfen von Ludwig
August Emerling, 3 Bände.

Emm.

Reufs's Orographie des Nord-
westlichen Mittelgebir-
ges, 1790.

Reufs. Mittelgeb.

Mineralogische Geographie
von Böhmen von F. A.
Reufs, 1793 and 1797. 2
Bänd. 4to.

Reufs Böhmen.

Versuch einer Mineralogie
nach des Herrn Bergcom-
missionraths Werner's Me-
thode von Abbe Eftner,
3 Bände, 1794.

Eftner.

Voyages dans les Alpes,
4 vol. in 4to. 1799 &
1796, by Sauffure.

Sauss.

Theorie de la Terre, t. 1
& 2, par la Metherie,
1797.

Lam.

Titles of Books.

Abbreviations under which they are designated.

Traité de Mineralogie, par }
 Abbe Haüy, 4 tom. 1801. } *Haüy.*

Traité Elementaire de Mi- }
 neralogie suivant les Prin- }
 cipes du Professeur Werner, }
 Conseiller des Mines de }
 Saxe, par J. A. Brochant, }
 2 tom. 1803. } *Broch.*

THE UNIVERSITY OF CHICAGO

PHYSICS DEPARTMENT

1925

1926

TABULAR VIEW

OF THE

MINERAL SYSTEM.

WATER VIEW

THE

MILNER WATER SYSTEM

MINERAL SYSTEM.

CLASS I.

EARTHY FOSSILS.

ENGLISH NAMES.

GERMAN NAMES.

1. DIAMOND GENUS.

<i>Species.</i>	<i>Gattung.</i>	<i>Page</i>
1. DIAMOND.	Diamant.	21

2. ZIRCON GENUS.

2. Zircon.	Zirkon.	28
3. Hyacinth.	Hyazinth.	33

3. FLINT GENUS.

4. Chrysoberyll.	Khrisoberill. <i>apate Genus</i>	39
5. Chrysolite.	Krifolith.	42

Garnet Family.

6. Olivine	Olivin.	55
7. Augite.	Augit.	56
8. Vesuvianite.	Vesuvian. <i>in continuation</i>	57
9. Leuzite.	Leuzit.	58
10. Melanite.	Melanit.	59
11. Garnet.	Granat. <i>amethyst y common</i>	60
<i>a.</i> Precious.	<i>a.</i> Edler.	
<i>b.</i> Common.	<i>b.</i> Gemeinet.	
12. Pyrope.	Pyrop. <i>Bohemian Garnet</i>	61
13. Grenatite.	Granatit.	66

Ruby Family.

- | | |
|-------------------|---------------|
| 14. Spinelle. | Spinell. |
| 15. Sapphire. | Saphir. |
| 16. Corundum. | Korund. |
| 17. Diamond spar. | Demant spath. |
| 18. Emery. | Schmiergel. |

-
- | | |
|------------|--------|
| 19. Topaz. | Topas. |
|------------|--------|

Schorl Family.

- | | |
|----------------------|--------------------------|
| 20. Emerald. | Schmaragd. |
| 21. Beryll. | Berill. |
| <i>a.</i> Precious. | <i>a.</i> Edler. |
| <i>b.</i> Schorlous. | <i>b.</i> Schörlartiger. |
| 22. Schorl. | Schörl. |
| <i>a.</i> Common. | <i>a.</i> Gemeiner. |
| <i>b.</i> Electric. | <i>b.</i> Elektrischer. |

-
- | | |
|------------------|--------------|
| 23. Thumerstone. | Thumerstein. |
|------------------|--------------|

Quartz Family.

- | | |
|--------------------------|---------------------------|
| 24. Iron flint. | Eisen kiesel. |
| 25. Quartz. | Quarz. |
| <i>a.</i> Amethyft. | <i>a.</i> Amethyft. |
| <i>α.</i> Common. | <i>α.</i> Gemeiner. |
| <i>β.</i> Thick fibrous. | <i>β.</i> Dick fafriger. |
| <i>b.</i> Rock cryftal. | <i>b.</i> Berg kristall. |
| <i>c.</i> Milk quartz. | <i>c.</i> Milch quarz. |
| <i>d.</i> Common quartz. | <i>d.</i> Gemeiner quarz. |
| <i>e.</i> Prafe. | <i>e.</i> Prafem. |
| 26. Hornstone. | Hornstein. |
| <i>a.</i> Splintery. | <i>a.</i> Splittriger. |
| <i>b.</i> Conchoidal. | <i>b.</i> Mufchlicher. |
| <i>c.</i> Woodstone. | <i>c.</i> Holzstein. |
| 27. Flint. | Feuerstein. |
| 28. Calcedony. | Kalzedon. |
| <i>a.</i> Common. | <i>a.</i> Gemeiner. |
| <i>b.</i> Carnelian. | <i>b.</i> Karniol. |

- | | |
|-------------------------|---------------------------|
| 29. Heliotrope. | Heliotrop. |
| 30. Chryfoprafe. | Krifopras. |
| 31. Plafma. | Plafma. |
| 32. Flint flate. | Kiefelfchiefer. |
| <i>a.</i> Common. | <i>a.</i> Gemeiner. |
| <i>b.</i> Lydian flone. | <i>b.</i> Lydifcherflone. |

-
- | | |
|----------------|-------------|
| 33. Cat's eye. | Katzenauge. |
|----------------|-------------|

Zeolite Family.

- | | |
|---------------------|-----------------------|
| 34. Prehnite. | Prehnit. |
| 35. Zeolite. | Zeolith. |
| <i>a.</i> Mealy. | <i>a.</i> Mehl. |
| <i>b.</i> Fibrous. | <i>b.</i> Fafriger. |
| <i>c.</i> Radiated. | <i>c.</i> Strahliger. |
| <i>d.</i> Foliated. | <i>d.</i> Blättriger. |
| <i>e.</i> Cubic. | <i>e.</i> Würfel. |
| 36. Crofs flone. | Kreuzflone. |

-
- | | |
|------------------|-------------|
| 37. Azure flone. | Lazurflone. |
|------------------|-------------|

4. CLAY GENUS.

- | | |
|-----------------------|------------------------|
| 38. Jafper. | Jafpis. |
| <i>a.</i> Egyptian. | <i>a.</i> Ägyptifher. |
| <i>b.</i> Striped. | <i>b.</i> Band. |
| <i>c.</i> Porcelain. | <i>c.</i> Porzellan. |
| <i>d.</i> Common. | <i>d.</i> Gemeiner. |
| <i>α.</i> Conchoidal. | <i>α.</i> Mufchlicher. |
| <i>β.</i> Earthy. | <i>β.</i> Erdiger. |
| <i>e.</i> Agate. | <i>e.</i> Agath. |
| <i>f.</i> Opal. | <i>f.</i> Opal. |
| 39. Opal. | Opal. |
| <i>a.</i> Precious | <i>a.</i> Edler. |
| <i>b.</i> Common. | <i>b.</i> Gemeiner. |
| <i>c.</i> Semi. | <i>c.</i> Halb. |
| <i>d.</i> Wood. | <i>d.</i> Holz. |
| 40. Pitchflone. | Pechflone. |
| 41. Obfidian. | Obfidian. |

42. Pearlflone.

- | | |
|--------------------------------|--------------------------|
| 42. Pearlstone. | Perlstein. |
| 43. Pumice. | Bimstein. |
| 44. Feldspar. | Feldspath. |
| <i>a.</i> Compact. | <i>a.</i> Dichter. |
| <i>b.</i> Common. | <i>b.</i> Gemeiner. |
| <i>α.</i> Fresh. | <i>α.</i> Frischer. |
| <i>β.</i> Disintegrated. | <i>β.</i> Aufgelöster. |
| <i>c.</i> Adularia. | <i>c.</i> Adular. |
| <i>d.</i> Labradorstone. | <i>d.</i> Labradorstein. |
| 45. Pure clay. | Reine thonerde. |
| 46. Procelain clay. | Porzellanerde. |
| 47. Common clay. | Töpfer thon. |
| <i>a.</i> Loam. | <i>a.</i> Leim. |
| <i>b.</i> Pipe clay. | <i>b.</i> Pfeiffen thon. |
| <i>c.</i> Potter's clay. | <i>c.</i> Töpfer thon. |
| <i>d.</i> Variegated clay. | <i>d.</i> Bunter thon. |
| <i>e.</i> Claystone. | <i>e.</i> Thonstein. |
| <i>f.</i> Slate clay. | <i>f.</i> Schiefer thon. |
| 48. Polishing or polier slate. | Polierschiefer. |
| 49. Tripoli. | Trippel. |
| 50. Alum stone. | Alaunstein. |
| 51. Alum earth. | Alaun erde. |

Slate Family.

- | | |
|-----------------------|-----------------------|
| 52. Alum slate. | Alaunschiefer. |
| <i>a.</i> Common. | <i>a.</i> Gemeiner. |
| <i>b.</i> Glossy. | <i>b.</i> Glänzender. |
| 53. Bituminous shale. | Brandtschiefer. |
| 54. Drawing slate. | Zeichenschiefer. |
| 55. Whet slate. | Wetztschiefer. |
| 56. Clay slate. | Thonschiefer. |

Mica Family.

- | | |
|-----------------------|-------------|
| 57. Lepidolite. | Lepidolith. |
| 58. Mica, or Glimmer. | Glimmer. |
| 59. Potstone. | Topfstein. |

60. Chlorite.

- | | |
|-----------------------|------------------------|
| 60. Chlorite. | Chlorit. |
| a. Chlorite earth. | a. Chlorit erde. |
| b. Common chlorite. | b. Gemeiner chlorit. |
| c. Chlorite slate. | c. Chloritschiefer. |
| d. Foliated chlorite. | d. Blättriger chlorit. |

Trap Family.

- | | |
|----------------------|------------------------|
| 61. Hornblende. | Hornblende. |
| a. Common. | a. Gemeiner. |
| b. Labrador. | b. Labradorische. |
| c. Basaltic. | c. Basaltische. |
| d. Hornblende slate. | d. Hornblendeschiefer. |

- | | |
|----------------------|-------------|
| 62. Basalt. | Basalt. |
| 63. Wacce, or Wacke. | Wakke. |
| 64. Clinkstone. | Klingstein. |
| 65. Lava. | Lava. |

- | | |
|-----------------|-----------|
| 66. Greenearth. | Grünerde. |
|-----------------|-----------|

Lithomarge Family.

- | | |
|-------------------|-------------------|
| 67. Lithomarge. | Steinmark. |
| a. Friable. | a. Zerreibliches. |
| b. Indurated. | b. Verhärtetes. |
| 68. Rock soap. | Bergseife. |
| 69. Yellow earth. | Gelberde. |

5. TALC GENUS.

Soapstone Family.

- | | |
|------------------------|----------------------|
| 70. Bole. | Bol. |
| 71. Native talc earth. | Natürliche talkerde. |
| 72. Meerschaum. | Meerschaum. |
| 73. Fullers earth. | Walkerde. |

Talc Family.

- | | |
|---------------|---------------|
| 74. Nephrite. | Nephrit. |
| a. Common. | a. Gemeiner. |
| b. Axestone. | b. Beilstein. |

75. Steatite.

- | | |
|--------------------------|----------------------------|
| 75. Steatite. | Speckstein. |
| 76. Serpentine. | Serpentin. |
| <i>a.</i> Common. | <i>a.</i> Gemeiner. |
| <i>b.</i> Precious. | <i>b.</i> Edler. |
| <i>α.</i> Conchoidal. | <i>α.</i> Muschlicher. |
| <i>β.</i> Splintery. | <i>β.</i> Splittriger. |
| 77. Schillerstone. | Schillerstein. |
| 78. Talc. | Talk. |
| <i>a.</i> Earthy. | <i>a.</i> Erdiger. |
| <i>b.</i> Common. | <i>b.</i> Gemeiner. |
| <i>c.</i> Indurated. | <i>c.</i> Verhærteter. |
| 79. Asbest. | Asbest. |
| <i>a.</i> Rock cork. | <i>a.</i> Berg kork. |
| <i>b.</i> Amianth. | <i>b.</i> Amiant. |
| <i>c.</i> Common asbest. | <i>c.</i> Gemeiner Asbest. |
| <i>d.</i> Rock wood. | <i>d.</i> Bergholz. |

Actynolite Family.

- | | |
|----------------------|--------------------------|
| 80. Kyanite. | Cianit. |
| 81. Actynolite. | Strahlstein. |
| <i>a.</i> Asbestous. | <i>a.</i> Asbestartiger. |
| <i>b.</i> Common. | <i>b.</i> Gemeiner. |
| <i>c.</i> Glassy. | <i>c.</i> Glasiger. |
| 82. Tremolite. | Tremolith. |
| <i>a.</i> Asbestous. | <i>a.</i> Asbestartiger. |
| <i>b.</i> Common. | <i>b.</i> Gemeiner. |
| <i>c.</i> Glassy. | <i>c.</i> Glasiger. |

6. CALC GENUS.

- | | |
|---------------------------|-----------------------------|
| 83. Rock milk. | Berg milch. |
| 84. Chalk. | Kreide. |
| *85. Limestone. | Kalkstein. |
| <i>a.</i> Compact. | <i>a.</i> Dichter. |
| <i>α.</i> Common compact. | <i>α.</i> Gemeiner dichter. |
| <i>β.</i> Roestone. | <i>β.</i> Rogenstein. |
| | <i>b.</i> Foliated |

<i>b.</i> Foliated limestone.	<i>b.</i> Blättriger kalkstein.
<i>a.</i> Granular.	<i>a.</i> Körniger.
<i>β.</i> Calc spar.	<i>β.</i> Kalkspath.
<i>c.</i> Fibrous limestone.	<i>c.</i> Fasriger kalkstein.
<i>a.</i> Common.	<i>a.</i> Gemeiner.
<i>β.</i> Calc sinter.	<i>β.</i> Kalksinter.
<i>d.</i> Peastone.	<i>d.</i> Erbsenstein.
85. Schaum earth, or calc shaum.	Schaumerde.
86. Slate spar, or shiver spar.	Schieferspath.
87. Brown spar.	Braunspath.
88. Rhomb spar.	Rautenspath.
89. Schalstone.	Schaalstein.
90. Stink stone.	Stinkstein.
91. Marle.	Mergel.
<i>a.</i> Marle earth.	<i>a.</i> Mergelerde.
<i>b.</i> Indurated marle.	<i>b.</i> Verhärteter.
92. Bituminous marl slate.	Bituminöser mergelschiefer.
93. Calctuf.	Kalktuff.
94. Arragone.	Arragon.
95. Appatite.	Apatit.
96. Spargel stone, or Aspa- ragus stone.	Spargelstein.
97. Boracite.	Borazit.
98. Fluor.	Fluß.
<i>a.</i> Compact.	<i>a.</i> Dichter.
<i>b.</i> Fluor spar.	<i>b.</i> Flußspath.
99. Gyps.	Gips.
<i>a.</i> Gyps earth.	<i>a.</i> Gipferde.
<i>b.</i> Compact.	<i>b.</i> Dichter.
<i>c.</i> Foliated.	<i>c.</i> Blättriger.
<i>d.</i> Fibrous.	<i>d.</i> Fasriger.
100. Selenite.	Fraueneis.
101. Cube spar.	Würfelspath.

7. BARYTE GENUS.

102. Witherite.	Witherit.
103. Baryte.	Schwerfspath.
<i>a.</i> Baryte earth.	<i>a.</i> Schwerfspatherde.
<i>b.</i> Compact baryte.	<i>b.</i> Dichter.
<i>c.</i> Granular.	<i>c.</i> Körniger.
<i>d.</i> Curved lamellar.	<i>d.</i> Krumm fchaaliger.
<i>e.</i> Straight lamellar.	<i>e.</i> Gerad fchaaliger.
<i>α.</i> Fresh.	<i>α.</i> Frischer.
<i>β.</i> Disintegrated.	<i>β.</i> Mulmicher.
<i>f.</i> Columnar spar.	<i>f.</i> Stangenspath.
<i>g.</i> Prismatic baryte.	<i>g.</i> Säulen schwerfpath.
<i>b.</i> Bolognese spar.	<i>b.</i> Bologneser fpath.

8. STRONTIANE GENUS.

104. Strontiane.	Stronthian.
105. Celestine.	Celestin.
<i>a.</i> Fibrous.	<i>a.</i> Fafriger.
<i>b.</i> Foliated.	<i>b.</i> Blättriger.

CLASS II.

FOSSIL SALTS.

106. Natural soda.	Natürliches mineral alkali.
107. Natural nitre.	Natürliches falpeter.
108. Natural rock falt.	Natürliches kochfalz.
<i>a.</i> Stone falt.	<i>a.</i> Steinfalz.
<i>α.</i> Foliated	<i>α.</i> Blättriges.
<i>β.</i> Fibrous.	<i>β.</i> Fafriges.
<i>b.</i> Sea falt.	<i>b.</i> See falz.
109. Natural fal ammoniac.	Natürlicher falmiak.
110. Natural vitriol.	Natürlicher vitriol.
111. Hair falt.	Haarfalz.

- | | |
|----------------------------|--------------------------|
| 112. Rock butter. | Bergbutter. |
| 113. Natural Epsom salt. | Natürliches Bittersalz. |
| 114. Natural Glauber salt. | Natürliches Glaubersalz. |

C L A S S III.

I N F L A M M A B L E F O S S I L S.

I. SULPHUR GENUS.

- | | |
|-----------------------|-------------------------|
| 115. Natural sulphur. | Natürlicher Schwefel. |
| <i>a.</i> Common. | <i>a.</i> Gemeiner. |
| <i>b.</i> Volcanic. | <i>b.</i> Vulcanischer. |

2. BITUMINOUS GENUS.

- | | |
|-------------------------------------|--------------------------|
| 116. Bituminous wood. | Bituminöses Holz. |
| <i>a.</i> Common. | <i>a.</i> Gemeines. |
| <i>b.</i> Bituminous wood
earth. | <i>b.</i> Erdkohle. |
| 117. Coal. | Steinkohle. |
| <i>a.</i> Brown coal. | <i>a.</i> Braunkohle. |
| <i>b.</i> Moor coal. | <i>b.</i> Moorkohle. |
| <i>c.</i> Pitch coal. | <i>c.</i> Pechkohle. |
| <i>d.</i> Glance coal. | <i>d.</i> Glanzkohle. |
| <i>e.</i> Columnar coal. | <i>e.</i> Stangenkohle. |
| <i>f.</i> Slate coal. | <i>f.</i> Schieferkohle. |
| <i>g.</i> Cannel coal. | <i>g.</i> Kannelkohle. |
| <i>b.</i> Foliated coal. | <i>b.</i> Blätterkohle. |
| <i>i.</i> Coarse coal. | <i>i.</i> Grobkohle. |
| 118. Mineral charcoal. | Mineralisches Holzkohle. |
| 119. Fossil oil. | Erdöl. |
| 120. Mineral pitch. | Erdpech. |
| <i>a.</i> Elastic. | <i>a.</i> Elastisches. |
| <i>b.</i> Earthy. | <i>b.</i> Erdiges. |
| <i>c.</i> Slaggy. | <i>c.</i> Schlackiges. |

- | | |
|--------------------|-----------------------|
| 121. Amber. | Bernstein. |
| <i>a.</i> White. | <i>a.</i> Weißer. |
| <i>b.</i> Yellow. | <i>b.</i> Gelber. |
| 122. Honey stone. | Honigstein. |
| 3. GRAPHITE GENUS. | |
| 123. Graphite. | Graphit. |
| <i>a.</i> Scaly. | <i>a.</i> Schuppiger. |
| <i>b.</i> Compact. | <i>b.</i> Dichter. |
| 124. Coalblende. | Kohlenblende. |

CLASS IV.

METALLIC FOSSILS.

1. PLATINA GENUS.

- | | |
|----------------------|------------------|
| 125. Native platina. | Gediegen platin. |
|----------------------|------------------|

2. GOLD GENUS.

- | | |
|---------------------------|--------------------------|
| 126. Native gold. | Gediegen gold. |
| <i>a.</i> Gold yellow. | <i>a.</i> Goldgelbes. |
| <i>b.</i> Brass yellow. | <i>b.</i> Messinggelbes. |
| <i>c.</i> Greyish yellow. | <i>c.</i> Graugelbes. |

3. QUICKSILVER GENUS.

- | | |
|-----------------------------|--------------------------|
| 127. Native quicksilver. | Gediegen quecksilber. |
| 128. Natural amalgam. | Natürliches amalgam. |
| <i>a.</i> Fluid. | <i>a.</i> Flüssiges. |
| <i>b.</i> Solid. | <i>b.</i> Festes. |
| 129. Quicksilver horn ore. | Quecksilber horn erz. |
| 130. Quicksilver liver ore. | Quecksilber leber erz. |
| <i>a.</i> Compact. | <i>a.</i> Dichtes. |
| <i>b.</i> Slaty. | <i>b.</i> Schiefriges. |
| 131. Cinnober. | Zinnober. |
| <i>a.</i> Dark red. | <i>a.</i> Dunkel rother. |
| <i>b.</i> Bright red. | <i>b.</i> Hoch rother. |

4. SILVER GENUS.

132. Native silver.	Gediegen Silber.
<i>a.</i> Common.	<i>a.</i> Gemeines.
<i>b.</i> Goldish.	<i>b.</i> Giltiges.
133. Antimonial silver.	Spiegelglas Silber.
134. Arsenic silver.	Arsenik Silber.
135. Horn ore.	Hornerz.
136. Silver black.	Silberschwärze.
137. Silver glance.	Glaferz.
138. Brittle silver glance.	Spröd glaferz.
139. Red silver ore.	Roth giltig erz.
<i>a.</i> Dark.	<i>a.</i> Dunkles.
<i>b.</i> Light.	<i>b.</i> Lichtes.
140. White silver ore.	Weißgiltig erz.
141. Black silver ore.	Schwartz giltig erz.

5. COPPER GENUS.

142. Native copper.	Gediegen Kupfer.
143. Copper glance.	Kupferglas.
<i>a.</i> Compact.	<i>a.</i> Dichtes.
<i>b.</i> Foliated.	<i>b.</i> Blättriges.
144. Variegated copper ore.	Bunt kupfererz.
145. Copper pyrites	Kupferkies.
146. White copper ore.	Weiß kupfererz.
147. Fahl ore.	Fahlerz.
148. Copper black.	Kupfer schwärze.
149. Red copper ore.	Roth kupfererz.
<i>a.</i> Compact.	<i>a.</i> Dichtes.
<i>b.</i> Foliated.	<i>b.</i> Blättriges.
<i>c.</i> Capillary.	<i>c.</i> Haarförmiges.
150. Tile ore.	Ziegelerz.
<i>a.</i> Earthy.	<i>a.</i> Erdiges.
<i>b.</i> Indurated.	<i>b.</i> Verhärtetes.
151. Copper azure.	Kupferlaser.
<i>a.</i> Earthy.	<i>a.</i> Erdige.
<i>b.</i> Radiated.	<i>b.</i> Strahlige.

152. Malachite.	Malachit.
<i>a.</i> Fibrous.	<i>a.</i> Fafriger.
<i>b.</i> Compact.	<i>b.</i> Dichter.
153. Copper green.	Kupfergrün.
154. Iron shot copper green.	Eifenschüffiges kupfergrün.
<i>a.</i> Earthy.	<i>a.</i> Erdiges.
<i>b.</i> Slaggy.	<i>b.</i> Schlackiges.
155. Oliven ore.	Olivenerz.
156. Copper mica.	Kupferglimmer.
157. Copper emerald.	Kupferschmaragd.

6. IRON GENUS.

158. Native iron.	Gediegen eisen.
159. Iron pyrites.	Schwefel kies.
<i>a.</i> Common.	<i>a.</i> Gemeiner.
<i>b.</i> Radiated.	<i>b.</i> Strahlkies.
<i>c.</i> Liver pyrites.	<i>c.</i> Leberkies.
<i>d.</i> Hair pyrites.	<i>d.</i> Haarkies.
160. Magnetic pyrites.	Magnétkies.
161. Magnetic iron stone.	Magnet eisenstein.
<i>a.</i> Compact.	<i>b.</i> Gemeiner.
<i>b.</i> Iron sand.	<i>b.</i> Eisen sand.
162. Iron glance.	Eisenglanz.
<i>a.</i> Common.	<i>a.</i> Gemeiner.
<i>a.</i> Compact.	<i>a.</i> Dichter.
<i>β.</i> Foliated.	<i>β.</i> Blättriget.
<i>b.</i> Iron glimmer, or iron mica.	<i>b.</i> Eifenglimmer.
163. Red iron stone.	Roth eisenstein.
<i>a.</i> Red iron stoth.	<i>a.</i> Rother eisenrahm.
<i>b.</i> Ochry red iron stone.	<i>b.</i> Ockriger rotheisen- stein.
<i>c.</i> Compact.	<i>c.</i> Dichter.
<i>d.</i> Red hematite.	<i>d.</i> Rother glaskopf.
164. Brown iron stone.	Braun eisenstein.
	<i>a.</i> Brown

- | | |
|---------------------------------------|---|
| <i>a.</i> Brown iron froth. | <i>a.</i> Brauner eisenrahm. |
| <i>b.</i> Ochry brown iron stone. | <i>b.</i> Ockriger brauneisenstein. |
| <i>c.</i> Compact. | <i>c.</i> Dichter. |
| <i>d.</i> Brown hematite. | <i>d.</i> Brauner glaskopf. |
| 165. Sparry iron stone. | Spath eisenstein. |
| 166. Black iron stone. | Schwartz eisenstein. |
| <i>a.</i> Compact. | <i>a.</i> Dichter. |
| <i>b.</i> Black hematite. | <i>b.</i> Schwarzer glaskopf. |
| 167. Clay iron stone. | Thon eisenstein. |
| <i>a.</i> Reddle. | <i>a.</i> Röthel. |
| <i>b.</i> Columnar clay iron stone. | <i>b.</i> Stänglicher thon eisenstein. |
| <i>c.</i> Lenticular clay iron stone. | <i>c.</i> Linsenförmiges thon eisenstein. |
| <i>d.</i> Jaspery clay iron stone. | <i>d.</i> Jaspifartigesthoneisenstein. |
| <i>e.</i> Common clay iron stone. | <i>e.</i> Gemeiner thon eisenstein. |
| <i>f.</i> Iron kidney. | <i>f.</i> Eisenniere. |
| <i>g.</i> Pea ore. | <i>g.</i> Bohnerz. |
| 168. Bog iron ore. | Rafen eisenstein. |
| <i>a.</i> Morass ore. | <i>a.</i> Morasterz. |
| <i>b.</i> Swamp ore. | <i>b.</i> Sumpferz. |
| <i>c.</i> Meadow ore. | <i>c.</i> Wiesenerz. |
| 169. Blue iron earth. | Blaue eisenerde. |
| 170. Green iron earth. | Grüne eisenerde. |

7. LEAD GENUS.

- | | |
|----------------------|------------------------|
| 171. Lead glance. | Bleiglanz. |
| <i>a.</i> Common. | <i>a.</i> Gemeiner. |
| <i>b.</i> Compact. | <i>b.</i> Bleischweif. |
| 172. Blue lead ore. | Blau bleierz. |
| 173. Brown lead ore. | Braun bleierz. |
| 174. Black lead ore. | Schwarz bleierz. |

175. White

175. White lead ore.	Weis bleierz.
176. Green lead ore.	Grün bleierz.
177. Red lead ore.	Roth bleierz.
178. Yellow lead ore.	Gelb bleierz.
179. Natural lead vitriol.	Natürlicher bleivitriol.
180. Lead earth.	Bleierde.
<i>a.</i> Coherent.	<i>a.</i> Feste.
<i>b.</i> Friable.	<i>b.</i> Zerreibliche.

8. TIN GENUS.

181. Tin pyrites.	Zinnkies.
182. Tin stone.	Zinnstein.
183. Cornish tin ore.	Kornisch zinnerz.

9. BISMUTH GENUS.

184. Native bismuth.	Gediegen wismuth.
185. Bismuth glance.	Wismuthglanz.
186. Bismuth ochre.	Wismuthocker.

10. ZINC GENUS.

187. Blende.	Blende.
<i>a.</i> Yellow.	<i>a.</i> Gelbe.
<i>b.</i> Brown.	<i>b.</i> Braune.
<i>c.</i> Black.	<i>c.</i> Schwarze.
188. Calamine.	Galmei.

11. ANTIMONY GENUS.

189. Native antimony.	Gediegen spießglas.
190. Grey antimony.	Grau spießglas.
<i>a.</i> Compact.	<i>a.</i> Dichtes.
<i>b.</i> Foliated.	<i>b.</i> Blättriges.
<i>c.</i> Radiated.	<i>c.</i> Strahliges.
<i>d.</i> Featherose.	<i>d.</i> Federerz.
191. Red antimony.	Roth spießglaserz.
192. White antimony.	Weiß spießglaserz.
193. Antimony ochre.	Spießglas oker.

12. COBALT GENUS.

- | | |
|---------------------------|--|
| 194. White cobalt ore. | Weisser speiffcobalt. |
| 195. Grey cobalt ore. | Grauer speiffcobalt. |
| 196. Cobalt glance. | Glanz kobalt. |
| 197. Black cobalt ochre. | Schwarzer erdkobalt. |
| <i>a.</i> Earthy. | <i>a.</i> Schwartzer kobalt
mulm. |
| <i>b.</i> Indurated. | <i>b.</i> Fester schwarzer erd-
kobalt. |
| 198. Brown cobalt ochre. | Brauner erdkobalt. |
| 199. Yellow cobalt ochre. | Gelber erdkobalt. |
| 200. Red cobalt ochre. | Rother erdkobalt. |
| <i>a.</i> Cobalt crust. | <i>a.</i> Kobalt beschlag. |
| <i>b.</i> Cobalt bloom. | <i>b.</i> Kobalt blüthe. |

13. NICKEL GENUS.

- | | |
|---------------------|---------------|
| 201. Kupfer nickel. | Kupfernickel. |
| 202. Nickel ochre. | Nickel ocker. |

14. MANGANESE GENUS.

- | | |
|---------------------------|------------------------|
| 203. Grey manganefe ore. | Grau braunsteinerz. |
| <i>a.</i> Radiated. | <i>a.</i> Strahliges. |
| <i>b.</i> Foliated. | <i>b.</i> Blättriges. |
| <i>c.</i> Compact. | <i>c.</i> Dichtes. |
| <i>d.</i> Earthy. | <i>d.</i> Erdiges. |
| 204. Black manganefe ore. | Schwarz Braunsteinerz. |
| 205. Red manganefe ore. | Roth Braunsteinerz. |

15. MOLYBDANE GENUS.

- | | |
|-----------------|-------------|
| 206. Molybdane. | Wasserblei. |
|-----------------|-------------|

16. ARSENIC GENUS.

- | | |
|-------------------------|---------------------|
| 207. Native arsenic. | Gediegen arsenic. |
| 208. Arsenical pyrites. | Arfenikkies. |
| <i>a.</i> Common. | <i>a.</i> Gemeiner. |
| <i>b.</i> Silverish. | <i>b.</i> Weisserz. |

D

209. Orpiment.

209. Orpiment.	Raufchgelb.
<i>a.</i> Yellow.	<i>a.</i> Gelbes raufchgelb.
<i>b.</i> Red.	<i>b.</i> Rothcs raufchgelb.

17. SCHEELE GENUS.

210. Tungften.	Schwerstein.
211. Wolfram.	Wolfram.

18. MENAC GENUS.

212. Menacan.	Menakan.
213. Rutile.	Rutil.
214. Nigrine.	Nigrin.
215. Iferine.	Iferin.

19. URAN GENUS.

216. Pitch ore.	Pecherz.
217. Uran mica.	Uranglimmer.
218. Uran ochre.	Uranocker.

20. SYLVAN GENUS.

219. Native fylvan.	Gediegen fylvan.
220. Graphic fylvan ore.	Schrifterz.
221. Yellow fylvan ore.	Weifs fylvanerz.
222. Black fylvan ore.	Nagiakererz.

MINERAL SYSTEM.

WENN irgend eine Wissenschaft, die ihren Verehrer aufzeichnen soll, den Muth des Enthusiasmus und das Ertragen von Mühe und Beschwerlichkeiten erfordert, so ist es der Mineralogie. Der Theolog, der Jurist, der Philosoph, der schöne Geist kann ein großer Mann auf seinem Studierzimmer werden, der Astronom vom Observatorium die Kreise der Welten beobachten, und sich einen unsterblichen Namen erwerben. Nicht so der Mineralog und Naturforscher. Die Natur mit ihren vielen Merkwürdigkeiten, und Geheimnissen, will selbst betrachtet seyn. Ihr Dienst ist der mühsamste, so wie ihre Kenntniß die reizendste und angenehmste. Auch hat die Göttin keiner Wissenschaft eifrigere Liebhaber, keine so viele, die die Märtyrer ihrer Ergebenheit und Studiums geworden sind.

MINERAL SYSTEM.

CLASS I.

EARTHY FOSSILS.

FIRST GENUS.

DIAMOND GENUS.

Diamond.

Demant, or Diamant.—*Werner.*

Alumen lapidosum pellucidissimum hyalinum, *Lin.*—*Gemma vera colore aqueo, Cartheus.*—Quartzum nobile, *Born.*—Diamond, *Kirw.* vol. i. p. 393.—Diamant, *Estner.* b. 2. f. 54. *Ibid. Emm.* b. 1. f. 187.—Le Diamant, *Broch.* t. 1. p. 153. *Ibid. Haüy Min.* t. 3. p. 287.

External Characters.

THE most common colours of the Diamond are white and grey. The varieties of white are snow white, greyish white, and yellowish white; of grey, ash grey, smoke grey, blueish grey, pearl grey, yellowish and greenish grey.

Besides

Besides these two colours, it occurs blue, red, brown, yellow, and green.

Of the blue the only variety which Werner possesses is indigo blue: it probably passes into red.

Of red it occurs rose red and cherry red; from the latter it passes into clove brown and yellowish brown; from this into ochre yellow, wine yellow, lemon and sulphur yellow: further into fiskin green, asparagus green, pistachio green, leek green, and lastly into mountain green: which latter probably passes into greenish grey.

The clove brown sometimes approaches to black. The indigo blue and the red are the rarest varieties. The snow white is the most highly valued, and the grey, and still more the brown, are the least valued.

The colours are most generally pale and light, seldom deep, and far seldomer dark.

It exhibits a most beautiful play of colours.

It occurs in indeterminately angular and completely spherical grains, which sometimes present planes of crystallization: it also occurs crystallized.

Its fundamental crystal is the octaedron, which passes on the one side,

1st, Into the simple three-sided pyramid, with truncated angles, and probably also into the six sided table, in which the terminal planes are set alternately oblique and straight on the lateral planes.

2d, On the other side it divides itself into three branches.

a. Octaedron.

- a.* Octaedron with bevilled edges, the bevilling planes cylindrically convex.
- b.* Octaedron with once broken bevilled edges.
- c.* Octaedron with truncated edges, and the truncating planes cylindrically convex.

When the bevilling planes of *a* become so large as to cause the planes of the octaedron to disappear, an octaedron is formed in which each plane is divided into three, and the dividing edge runs from the middle point to the angles.

When the planes of *b* increase in the same proportion, every plane of the octaedron becomes divided into six, so that three edges run from the middle point to the middle of the lateral edges, and three to the angles of the octaedron.

When the truncating planes of *c* increase so much as to cause the original ones to disappear, the garnet dodecaedron with cylindrical convex lateral planes is formed. Of this figure the following varieties and twin crystals occur.

1. When the planes of the acuminations very nearly touch each other, a double three-sided pyramid is formed.
2. Garnet dodecaedron with divided planes; in this figure each plane is divided into two, and the dividing edge passes through the obtuse angle of the rhomb.
3. If two crystals resembling the preceding, but with undivided planes, are turned around a sixth of their periphery, and pushed into each other, a very flat three-sided pyramid is formed,

formed, in which the lateral planes of the one are set on the lateral planes of the other, and the remains of the prisms form four-planed acuminations on the angles of the common base.

4. If two garnet dodecaedrons, with divided planes, are turned around a sixth of their periphery, and pushed into each other, a very short six-sided prism is formed, which is deeply and flatly acuminated on both extremities by six planes, which are set on the lateral planes.
5. When the prism of four disappears a double six-sided pyramid is formed.

The crystals are small and very small, seldom middle sized, and very rarely large.

The surface in the octaedron is smooth, also streaked; that of the grains uneven, granulated, also sometimes approaching to drussy, and frequently rough.

Externally its lustre alternates from splendid to glimmering; internally it is always splendid, even often specularly splendid, and adamantine.

The fracture is straight and perfectly foliated with a fourfold equiangular cleavage, and the cleavages are parallel with the sides of the octaedron.

The fragments are octaedral, or in the figure of a tetraedral pyramid.

It is commonly unseparated, (*unabgesondert*) yet it sometimes very rarely occurs in small and fine-grained distinct concretions.

Commonly

Commonly it is not completely transparent; in most cases it rather inclines to semitransparent.

Hard in the highest degree.

Brittle.

Not particularly difficultly frangible.

Not particularly heavy; approaching heavy.

Specific gravity—3,600, *Werner*—3,400, *Wallerius*—3,500, *Cronstedt*—3,518, *Muschenbroeck*—3,521, *Briffon*—3,666, *Muschenbroeck*, yellow brasilian.

Constituent Parts.

Boece de Boot, in his History of Gems, published in 1609, conjectured that the diamond was an inflammable substance. In 1673 Mr Boyle discovered, that when exposed to a high temperature, part of it was dissipated in acrid vapours. In 1694 and 1695 a series of experiments was made in presence of the Grand Duke of Tuscany, which confirmed those of Mr Boyle, and shewed, that the diamond, although the hardest of fossils, agreed with combustible bodies in being combustible. In 1704 Sir Isaac Newton, in his great work on Optics, hinted, that from its very great refracting power, it might be an unctuous substance coagulated*. The experiments of Darcet,

* Newton does not appear to have been acquainted with the experiments made in Tuscany; and besides, a considerable part of his work on Optics was written in 1675.

Lavoisier, Tennant, Lampadius, and Morveau, have demonstrated that it is nearly pure carbone.

Chemical Characters.

Begins to burn at a temperature not exceeding 14° or 15° of Wedgewood*.

Physical Characters.

It shews signs of positive electricity by rubbing; and it is said to shine in the dark, after having been exposed for some time to the rays of the sun. This latter property is denied by Werner, who affirms that he repeatedly made the experiment, but without success.

Geognostic Situation.

It is found sometimes loose in sand, sometimes inclosed in a loamy earth. Its original repository (*lagerstätte*) is still imperfectly known. Werner suspects that it occurs, like hyacinth, zircon, pyrope and spinelle, imbedded in rocks belonging to the newest floetz trap formation.

* Nicholson's Journal, v. 104.

Geographic Situation.

It is found in India and South America. In India it occurs chiefly in the provinces of Golconda, Vifapour, and at the foot of the Orixa mountains in Bengal. It is said to have been found in the peninsula of Malacca and the island of Borneo. In South America it has hitherto been only found in the district of Serra Dofrio, in Brazil.

Use.

The uses of diamond in jewellery, and for cutting hard fossils are well known : the detail respecting the different modes of cutting, polishing, and valuing, will be given in that part of this work which treats of Oeconomical Mineralogy.

SECOND GENUS.

ZIRCON GENUS.

FIRST SPECIES.

Zircon.

Zirkon.—*Werner*.

Topazius clarus hyalinus jargon, *Wall*, t. 1. p. 252.—
 Jargon de Ceylan, *Rome de L.* t. 1. p. 229. *Id. Born.*
 t. 1. p. 77.—Zirkon, *Wid.* f. 233. *Id. Kirw.* vol. 1.
 p. 257. *Id. Estner.* b. 2. f. 35. *Id. Emm.* b. 1. f. 3.
 —Giargone, *Nap.* p. 105.—Zircon, *Lam.* t. 2. p. 204.
Id. Broch. t. 1. p. 139. *Id. Haüy.* t. 2. p. 465.

External Characters.

Its chief colour is grey; but it occurs also green, blue, red, yellow, and brown.

The varieties of grey are greenish, yellowish, ash, and smoke grey; sometimes it approaches to blueish grey. The smoke and ash grey varieties, when pale, approach to white.

The yellowish grey sometimes passes into yellow.

The green passes into oil-olive, and into an intermediate colour between pistachio and leek green, and even into grass green. From the olive green it passes into broccoli brown, (which is characteristic

characteristic of zircon), from this into plumb blue, and columbine red; and lastly into yellowish and reddish brown.

The colours are sometimes dark, sometimes very dark, and also light; and from their falling more or less into grey are always a little muddy.

It occurs most commonly in roundish angular pieces, which have almost always rounded angles and edges. Also crystallized; the figures of its crystals are as follows:

1. A rectangular four-sided prism somewhat flatly acuminate by four planes, which are set on the lateral planes.

Of this figure the following varieties occur:

1. The lateral edges truncated.
 2. The angles formed by the acuminating and lateral planes bevelled; when these intersect, create,
 3. Very acute eight planed acumination is formed.
2. A very flat octaedron which is formed by the meeting of the two acuminations. It is either perfect, or the edges or angles on the common basis are truncated.

The crystals are almost always small and very small, very seldom middle sized, and still seldomer large. They are all around crystallized (*um und um crystallisirt*), consequently have been formed imbedded.

Surface of the crystals generally smooth, and, when it has been well preserved, is shining, bordering on strongly splendent; that of the angular pieces is sometimes

sometimes uneven and sometimes rough, and is glistening.

Internally its lustre is strongly splendid, and resinous, passing into adamantine.

Fracture perfectly small conchoidal.

Fragments indeterminately angular, sharp-edged.

It is intermediate between transparent and semi-transparent, and approaches sometimes more to the one, sometimes more to the other, and is duplicating transparent*.

Hard in a high degree, very little affected by the file †.

Brittle.

Not particularly difficultly frangible.

Heavy.

Specific gravity—4,700, *Werner*.—4,615, *Klaproth*.—4,6666, *Karsten*.

Constituent Parts.

Zirconia,	69,0
Silica	26,50
Oxyd of iron,	0,50
	<hr/>
	96,0

Klaproth, b. i. f. 222.

* Haüy.

† Eftner.

Chemical Characters.

It is infusible without addition by the blow pipe; with borax it forms a colourless transparent glass.

Geognostic Situation.

The manner of its occurrence has not as yet been satisfactorily ascertained. Werner, from its granular external shape, and the nature of the country where it is found, suspects that it occurs imbedded in rocks belonging to the newest floetz trap formation.

Geographic Situation.

In the island of Ceylon, where it was first discovered, it is found in the sand of a river, accompanied by crystals of spinelle, tourmaline, ceylanite, &c. and Kammerrath Von Schlotheim and Brochant inform us that it has been lately found at Friedrichschwärn in Norway, imbedded in a rock composed of hornblende and felspar*.

* Probably floetz greenstone,

Use.

It is frequently cut as a precious stone, and employed for various purposes, but particularly as an ornament in mourning dress. When it is cut it exhibits in a faint degree the play of colours of the diamond; and such varieties are not unfrequently sold as inferior kinds of diamond, and used by watch-makers in jewelling watches.

Observations.

On account of its great hardness and considerable fire, some of the older mineralogists believed it to be a variety of diamond; and others, from its colours, have placed it successively with topaz, sapphire, and ruby. The sagacious Romé de Lisle, however, suspected that it was essentially different from all these stones; and Werner, by an accurate examination of its external characters, referred it to its present place in the system.

SECOND SPECIES.

Hyacinth.

Hiacinth.—*Werner*.

Lyncurium veterum Hill. *Theophr.* 127.—*Topazium flavum rubens*, hyacinthus, *Wall.* t. 1. p. 252.—Hyacinthe, *Bruckman, Abhandl. v. d. Edelst.* f. 109. *Rome d. L.* t. 2. p. 281. *Dessen Beiträge hierzu.* f. 65. *Born.* t. 2. f. 77. *Wid.* f. 254. *Kirw.* vol. 1. p. 257. *Esfner.* b. 2. f. 141. *Reufs's Mittelgebirge,* f. 147. *Emm.* b. 1. f. 205. *Giacinto, Nap.* p. 109.—L'Hyacinthe, *Broch.* t. 1. p. 163.

External Characters.

Its chief colour is hyacinth red, which passes on the one side into reddish brown, on the other into orange yellow. From the reddish brown it passes into pale blood red, flesh red, pearl grey, reddish and greyish white; and from the pearl grey into blueish grey, smoke grey, and yellowish grey. From the orange yellow it passes into greenish grey and greenish white. The white and grey varieties are the rarest. It occurs in grains, and also crystallized. The crystals are,

The rectangular four-sided prism, flatly (more acute than the zircon) acuminated by four planes, which are set on the lateral edges.

Of this figure the following varieties occur :

1. The lateral edges truncated : when these truncations increase,
- 2: The zircon crystal is formed.
3. When the prism becomes lower and lower and the acuminations approach so near that they touch each other in a point, the garnet dodecaedron is formed.
4. The garnet dodecaedron sometimes passes into a very flat octaedron. This is the rarest figure.

The crystals are small, seldom middle sized, and very rarely large.

They are always imbedded.

The lateral planes are always smooth, and externally shining.

Internally it is splendent ; and vitreous, inclining a little to resinous.

Its fracture is perfectly straight foliated, twofold cleavage. The folia cross each other rectangularly in the direction of the diagonal, so that they intersect each other in the line of the axis of the prism.

The fragments are indeterminately angular, sharp edged.

It is transparent passing into translucent, and is duplicating transparent *.

Very hard ; scratches quartz †.

* Haüy.

† Haüy.

Not particularly difficultly frangible.

Feels a little greasy when cut.

Not particularly heavy, passing to heavy.

Specific gravity—4,0000, *Karsten*—4,545 and 4,620, *Klaproth*—4,386, *Hauy*.

Constituent Parts.

Hyacinth of Ceylon.		Hyacinth of Expailly.	
Zirconia	70	64,5	66,0
Silica	25	32,0	31,0
Oxyd of iron	0,50	2,0	2,0
Loss	4,50	1,5	1,0
	—————	—————	—————
	100,	100,	100,

Klaproth, b. i. f. 231.

Vauquelin, (J. d. M. N. 26. p. 106.)

Chemical Characters.

Exposed to the blow pipe it loses its colour, but not its transparency. It is infusible, excepting with borax, which converts it into a white transparent glass. *Vauquelin*. Exposed to a stream of oxygen gas it melts into a greyish white glass bead. *Lampadius*.

Geognostic Situation.

In Bohemia it is found in rocks belonging to the newest floetz trap formation (probably Wacce); and in Ceylon it occurs in sand, accompanied with spinelle sapphire, oriental ruby, zircon, tourmaline, ceylanite, and iron sand, according to the observations of the Count de Bournon.

Geographic Situation.

The Island of Ceylon, which is so remarkable for the variety of gems which it affords, is the principal place of occurrence of hyacinth. It is found also in Spain, near Lisbon in Portugal, in the rivulet Expailly in Auvergne in France, in Italy, and at Meronitz and Hohenstein in Saxony; probably also at the Ely in Fifeshire in Scotland.

Use.

It takes a fine polish, and when it is pure (particularly the red and yellow) is very much prized: it is however very often vesicular, which diminishes its value and beauty.

Observations.

Observations.

The hyacinth of Werner is the lyncurium of the ancients ; and the amethyst of modern writers appears to be their hyacinth.

THIRD GENUS.

FLINT GENUS.

FIRST SPECIES.

Chryfoberyll.

Krifoberill.—*Werner*.

Chryfolithus colores reflectens varios, chryfoberyllus, *Wall*, t. 1. p. 256.—Krifoberil, *Wid.* f. 246.—*Ibid.* *Kirw.* vol. 1. p. 261. *Efner*, b. 2. f. 63. *Ibid.* *Emm.* b. 1. f. 19. Crifoberillo.—*Nap.* p. 134.—Chryfopal, *Lam.* t. 2. p. 244.—Le Chryfoberil, *Broch.* t. 1. p. 167.—Cymophane, *Hauy.* t. 2. p. 491.

External Characters.

Its chief colour is asparagus green; it passes on the one side into apple green, mountain green, and greenish white; on the other side it passes through light olive and oil green into light yellowish grey, which inclines strongly to brown, and even passes to reddish brown.

It exhibits a milk white light (*schein*), which is very characteristic; when this light inclines much to blue, it is said to opalesce.

It occurs in roundish and angular grains, which sometimes approach in shape to the cube, and which have generally worn (obsolete) edges; also in rolled pieces. It occurs but seldom crystallised. The following are its crystalline figures:

1. Longish thick six sided table, having truncated lateral edges, and longitudinally streaked lateral planes.
2. When the truncating planes increase, the table passes into a double six-sided pyramid, in which the summits of the acuminations are sometimes truncated.

The crystals are small.

The surface of the grains is intermediate between rough and smooth, and is glistening.

The crystals are externally shining, internally splendid, and intermediate between resinous and vitreous, but more approaching the first.

Its fracture is perfectly conchoidal.

Fragments indeterminately angular and sharp-edged. Semitransparent and faintly transparent.

Hard; scratches quartz*.

Brittle.

Not particularly easily frangible.

Not particularly heavy, approaching heavy.

Specific gravity—3,600, 3,720, *Werner*.—3,710, *Klaprotb.*—3,7961, *Haüy*.

* *Haüy*.

Constituent Parts.

Alumina	71,5
Silica	18,0
Lime	6,0
Oxyd of iron	1,5
Lofs	3,0
	<hr/>
	100

According to *Klaproth*, b. 1, f. 102.

Chemical Characters.

Before the blow pipe it is infusible without addition, (*Lelievre*.)

Geognostic Situation

Is still unknown. Werner suspects that the grains occur imbedded.

Geographic Situation.

It is found in Brazil, and, according to Count de Bournon, in the sand of Ceylon, along with rubies, sapphires, &c.

Use.

Use.

It is sometimes cut for ring stones, and is usually set with a yellow foil; it is however rare and very seldom to be met with in the possession of jewellers.

Observation.

It is known in commerce by the name of opalescent, or oriental chrysolith.

SECOND SPECIES.

Chrysolite.

Krisolith.—*Werner*.

Chrysolithus obscure virescens, *Wall.* p. 256.—Kryolith, *Wid.* 264.—Chrysolité, *Kirw.* vol. 1. p. 262. *Id. Estner.* b. 2. f. 122. *Id. Emm.* b. 1. f. 26.—Chrysolito nobile, *Nap.* p. 127. *Peridot. Lam.* t. 2. p. 250.—La Chrysolithe, *Broch.* t. 1. p. 170. *Peridot. Haüy.* t. 3. p. 198.

External Characters.

Its chief colour is pistachio green, of all degrees of intensity: some varieties approach to the olive green, others to grass green, and even to broccoli brown. Certain rare varieties exhibit spots of a clove brown colour. In some specimens, besides the green colour, cherry red tints are to be observed.

It occurs sometimes in original angular pretty sharp edged pieces, which are frequently notched, and exhibit a peculiar rough scaly splintery surface; also in rolled pieces, and crystallized.

Its crystallizations are as follows:

1. A broad rectangular four-sided prism, having its lateral edges sometimes truncated, sometimes

times bevelled, and acuminated by six planes of which two opposite ones are placed on the smaller lateral planes, and the other four on the planes formed by the truncation of the lateral edges. The summit angle formed by the meeting of the four planes is more acute than that formed by the meeting of the two.

2. Differs from the preceding only in having two additional acuminating planes which are set on the larger lateral planes, between the planes which are set on the truncating planes.
3. The figures No. 1 and 2 have sometimes their summits truncated by a cylindrical convex plane, the curvature of which extends between the smaller planes of the acumination.
4. Some crystals are so thin that the smaller lateral planes almost entirely disappear, and the larger ones are a little curved, so that the crystal has a tabular aspect.

The lateral planes are deeply longitudinally streaked. The crystals are small and middle sized.

The external surface of the crystals is splendid, internally splendid and vitreous.

Fracture perfectly conchoidal.

Fragments indeterminately angular sharp edged.

It is perfect and duplicating transparent.

Hard in a low degree.

Brittle.

Easily frangible.

Not particularly heavy, approaching to heavy.

Specific gravity—3,340, 3,410, *Werner*.—3,428, *Haüy*.

Chemical Characters.

Before the blow pipe it is infusible without addition; with borax it forms a transparent green glass. *Vauquelin*.

Constituent Parts.

	Crystallized.	Cut.	Crystallized.
Silica	38,0	39	38
Magnesia	39,5	43,5	50,5
Oxyd of iron,	19,0	19,0	9,5
Lofs	3,5		2,0
	100	101,5	100
	<i>Klaproth.</i>		<i>Vauquelin.</i>

Geognostic Situation

Is not well known; *Werner* suspects that it occurs imbedded.

Geographic

Geographic Situation.

Is found principally in Upper Egypt: it has been also found in Bohemia; and, according to Brochant, in the isle of Bourbon.

Use.

It is employed as a precious stone in different kind of jewellery, but on account of its inferior hardness not very highly valued.

Observations;

1. Werner is of opinion that the stone described by the ancients, under the name of yellow chrysolite, is not the true chrysolite, but our Topaz.
2. Romé de Lisle and Born have described spargel stone by the name chrysolite; and other writers have confounded it with chrysoberyl and oil green beryl; and several of the most distinguished French mineralogists still consider it but as a variety of Olivine.

THIRD SPECIES:

Olivine.

Olivin.—*Werner*.

Chrysolite en grains irreguliers, *De Born*. t. 1. p. 70.
 —Olivin, *Wid.* f. 261. *Id. Kirw.* vol. 1. p. 263. *Id.*
Emm. b. 1, f. 35 —Chrysolite commune, *Nap.* p. 131.
 Olivine, *Lam.* t. 2. p. 278. *Id. Broch.* t. 1. p. 175.—
 Peridot granuliforme, *Haüy.* t. 3. p. 205.

External Characters.

Its most frequent colour is asparagus green of different degrees of intensity; seldom inclining to olive and pistachio green. An intermediate colour between asparagus and olive green may be considered as its characteristic colour.

When it is weathered it passes into a kind of yellowish brown.

It occurs imbedded, also in roundish pieces, and grains, and, very rarely, crystallized in rectangular four-sided prisms.

Internally it is shining, sometimes inclining to glistering, sometimes to splendid; and is resinous.

It

It has an imperfectly small conchoidal fracture, which passes sometimes into the splintery and uneven. The crystalized has sometimes an imperfectly foliated fracture, with a two-fold cleavage, and such varieties possess the greatest transparency and lustre.

Its fragments are indeterminately angular and sharp edged.

The larger pieces and grains show a tendency to small grained distinct concretions.

Semitransparent, which passes into translucent and transparent.

Very easily frangible.

In a low degree hard.

Not particularly heavy.

Specific gravity—3,225, *Werner*.—3,265, *Klaproth*.

Chemical Characters.

Before the blow pipe it is nearly infusible without addition; with borax it melts into a dark green bead. It loses its colour in nitrous acid, the acid dissolving the iron, which is its colouring ingredient.

Constituent Parts.

	Olivine of Unkel.		Olivine of Karlsberg a little decomposed.
Silica	48	to 50	52
Magnesia	37	to 38,50	37,75
Lime	0,25	also 0,20	0,12
Oxyd of iron	12,5	also 12,0	10,75
Lofs	2,25		
	<hr/>	<hr/>	<hr/>
	100,62	100,70	100,62

*Klaproth, b. i. f. 112.**Geognostic Situation.*

It occurs imbedded in basalt, and is generally accompanied with augite. Brochant supposes that it is sometimes of a posterior origin to the rock in which it is found, because it occurs in roundish pieces that appear to have filled pre-existing spaces; he has not, however, adduced any fact to render this opinion probable. Karsten mentions that he found boulders of olivine inclosed in the basalt, behind Landeck in the county of Glatz *. This will not appear improbable, when we recollect that the newest floetz trap has been often repeated; contemporaneous pieces may, however, have been mistaken for rolled pieces.

* Neue schriften der Gesellschaft naturforsch. Freunde. Berlin, b. 1. f. 266.

Geographic Situation.

It occurs very abundantly in Bohemia; also in Hungary, Stiermark, Austria, France, England, Ireland, Scotland, Sweden, Iceland, and Norway. Pieces the size of a man's head are found in the Habichtswalde and at Lichtenwalde.

Observations.

1. Hauy unites this species with the chrysolite, and names it peridot granuliforme. This arrangement cannot be admitted, because olivine differs from chrysolite or peridot in colour, in form, in frequency of crystallization, in having distinct concretions, and possessing greater frangibility.

2. The name olivine is derived from the olive green colour, which is characteristic of it.

FOURTH SPECIES.

Augite.

Augit.—*Werner*.

Pyroxene, *Daub.* p. 11.—Augit, *Estner*, b. 2. f. 129. *Id.*
Emm. b. 3. f. 241.—Volcanite, *Lam.* t. 2. p. 327.—
 L'Augite, *Broch.* t. 1. p. 179.—Pyroxene, *Hauy.* t. 3.
 p. 80.

External Characters.

Its chief colour is blackish green, which sometimes passes into greenish black; it seldom passes to leek green and still feldomer into a kind of liver brown.

It occurs mostly in indeterminately angular pieces and roundish grains, and sometimes crystallized. Its crystallization is as follows:

Broad rectangular six-sided prism, with two broader and four smaller lateral planes, bevelled on both extremities, and the bevilling planes set obliquely but parallelly on those lateral edges, which are formed by the smaller lateral planes. When these edges are truncated it forms an eight-sided prism, where the bevilling

villing planes are set on the two smaller opposite lateral planes*.

The crystals are mostly small, seldom middle sized, and are all around crystallized, and imbedded.

Internally its lustre is shining, which approaches sometimes to glistening, sometimes to splendid, and is resinous.

Its fracture is uneven, passing to imperfectly small conchoidal, and approaching sometimes to perfectly conchoidal. Some varieties, particularly the crystallized, present an imperfectly foliated fracture, which passes into perfectly foliated, with a twofold obliquely intersecting cleavage †.

Fragments indeterminately angular, pretty sharp edged.

It is only translucent, and faintly transparent, on account of the darkness of its colours: the splendid variety, with conchoidal fracture, possesses the greatest degree of transparency.

Hard.

Not particularly easily frangible.

Not particularly heavy, approaching to heavy.

Specific gravity — 3,471, *Werner*.—3,777, *Reufs*.—3,2265, *Haüy*.

* It is said to occur also in twin crystals.

† Dr. Reufs asserts that he observed a threefold cleavage, and Brochant states the same observation. The shape of the fragments shews this to be a mistake.

Chemical Characters.

Before the blow pipe, in small pieces, it is with difficulty converted into a black enamel.

Constituent Parts.

Silica	52,00
Lime	13,20
Alumina	3,33
Magnesia	10,00
Oxyd of iron	14,66
—— of manganese	2,00
Loss	4,81
	<hr/>
	100,00

Vauquelin. J. d. M. N. 39. p. 176.

Geognostic Situation.

It occurs principally in basalt, and either alone or accompanied with olivine.

Geographic Situation.

It is found very abundantly in Bohemia, also at Landeck in the county of Glatz, in Transilvania, in
Hungary,

Hungary, in Hesse, in Saxony near Aunaberg, in Scotland, as at Arthur's Seat near Edinburgh, and remarkably fine in the Island of Rume, one of the Hebrides, and equally beautiful at Arendal in Norway.

Observations.

1. Augite is distinguished from olivine by its darker colours, different crystallization, greater hardness, and specific gravity. It also resists decomposition much longer than olivine.

2. Olivine, augite, and hornblende, particularly the basaltic, appear to have much affinity with each other.

3. It used formerly to be considered as a product of fire; but the circumstance of its occurring wrapped up, not imbedded in the lava, demonstrates, as was first observed by Werner, that it is one of the constituent parts of the mother stone, which has escaped fusion.

A specimen of Augite brought by the late Mr. James Hall from the island of Rume, in the Hebrides, is now in the Cabinet of Minerals in the Museum of the University of Edinburgh.

FIFTH SPECIES.

Vesuviane.

Vesuvian.—*Werner*.

Hyacinth du Vesuve, *Rome de L.* t. 2. p. 291.—Vulcanischer schorl, *Wid.* f. 290.—Vesuvian, *Estner.* b. 2. f. 177. *Id. Emm.* b. 1. f. 342.—Hyacinthine, *Lam.* t. 2. p. 323.—La Vesuvienne, *Broch.* t. 1. p. 184.—Idocrase, *Haüy.* t. 2. p. 574.

External Characters.

Its principal colour is dark olive green, which sometimes passes into blackish green, sometimes to liver brown, and borders even on reddish brown. It occurs also of a light olive green, which inclines to oil green.

It occurs massive, often also crystallized. Its crystalline figures are as follows :

Rectangular four-sided prism, pretty deeply truncated on the terminal and lateral edges, and the edges of the truncation slightly truncated.

Sometimes the truncations on the terminal edges are so large, that they become acuminate ones, and thus the prism is flatly acuminate by four planes,
which

which are set on the lateral planes. The summit of the acumination is often more or less deeply truncated.

The lateral planes are slightly longitudinally streaked, but the planes of acumination are smooth.

The crystals are mostly short and placed on one another, and form druses; seldom imbedded; are small and middle sized.

Externally the surface of the crystals alternates between glistening and splendid; internally it is glistening, and the lustre intermediate between vitreous and resinous.

Fracture small grained uneven.

It shews a tendency to small grained distinct concretions.

Translucent, approaching sometimes to semitransparent.

Hard, but not in a very high degree.

Not particularly heavy, approaching to heavy.

Specific gravity—3,575, *Werner*.—Of Vesuvius 3,420, of Siberia 3,365 to 3,390, *Klaproth*.—3,407, *Hauy*.

Chemical Characters.

Before the blow pipe it melts, without addition, into a yellowish and faintly translucent glass.

Constituent Parts.

Vesuviane of Vesuvius,		of Siberia:
Silica	35,50	42,0
Lime	33,0	44,0
Alumina	22,25	16,25
Oxyd of iron	7,5	5,50
— of manganese	0,25	scarcely perceptible.
	<hr/>	<hr/>
	98,50	97,75
	<i>Klaproth, b. 2. p. 32. & 38.</i>	

Geognostic and Geographic Situations.

It is found among the exuviae of Vesuvius, in a rock composed of mica, hornblende, garnet, and calc spar, which is supposed by Werner to constitute part of the primitive mass on which that celebrated volcanic mountain rests. It has been also found in Siberia, in the peninsula of Kamtschatka, at the mouth of the rivulet Achtaragada; but the nature of the rock in which it there occurs remains still undetermined.

Use.

At Naples it is cut into ring stones, and is sold under various names, as chrisolite, hyacinth, &c.

Observation.

Observations.

It has been described under various denominations, as volcanic schorl, chrysolite, hyacinth; and topaz: Werner gave it its present name and place in the system.

The finest specimen of this mineral in the world is in the Gemmological Museum.

SIXTH SPECIES.

Leuzite.

Leuzit.—Werner

Grenat d'un blanc cristallin, et grenat dicolore. *R. d. L.* p. 330.—Grenat d'un blanc mat a 24 facettes. *Born,* t. 1, p. 436. *Leuzit. Wid.* f. 292.—Vesuvian or white garnet, *Kir.* vol. 1. p. 285.—Leuzit. *Estner.* b. 2. f. 188. *Ibid. Emm.* b. 1. f. 348. *Ibid. Lam.* t. 2. p. 259. *Id. Broch.* t. 1. 188. *Amphigene Haüy.* t. 2. p. 559.

External Characters.

Its colours are yellowish and greyish white; these, although rarely, pass into light ash grey, or yellowish grey; and it very seldom occurs reddish white.

It occurs most frequently in original, round, and angular grains; also crystallized, in acute, double, eight-sided pyramids, in which the lateral planes of the one are set on the lateral planes of the other, and the summits are deeply and flatly acuminate by four planes, which are conformably-wise set on the alternate edges.

The crystals often shew a tendency to form grains, and conversely the grains to form crystals.

The crystals are always all around crystallized and imbedded; they are commonly small, seldom middle sized.

The surface of the grains is rough, and dull, or weakly glimmering; that of the crystals is smooth, seldom slightly streaked, and glistening. Internally it is shining, approaching to glistening, and the lustre is vitreous, which inclines a little to resinous.

Fracture imperfectly and flat conchoidal, and inclines sometimes to foliated.

Fragments indeterminately angular, pretty sharp edged.

It is translucent, semitransparent, and some varieties approach to transparent.

Hard in a low degree.

Brittle.

Easily frangible.

Not particularly heavy, almost approaching to light.

Specific gravity.—2,468, *Brisson*.—2,464, *Kirwan*.—2,455 to 2,490, *Klaproth*.—2,461, *Karsten*.

Chemical Characters.

Before the blowpipe it is infusible without addition: with borax it forms a brownish-transparent glass. According to Lampadius, when exposed to a stream of oxygen gas, it melts easily into a white transparent glass.* Esmark affirms, that before the blow pipe it is fusible without addition†: it is probable, however, that his experiments were made on a variety of cubic zeolite.

Constituent Parts.

Mean of different analyses.

Silica	54	56
Alumina	24	20
Potash	21	20
Lime		2
Loss	1	2
	-----	-----
	100	100

Klaproth.

Vauquelin.

* Lampadius Samml. prakt. chem. Abhandl. b. 2. f. 62.

† Newes bergmänn. journ. 1798. b. 2. f. 21.

SEVENTH SPECIES.

Melanite.

Melanit.—*Werner*.

Black garnet of mineralogists.

External Characters.

Its colour is velvet black, which sometimes inclines to greyish black.

It occurs crystallized; probably also in grains.

Its crystalline figure is a six-sided prism, flatly acuminate by three planes, which are placed on the alternate lateral edges; and the edges are more or less truncated.

It is all around crystallized, and consequently has been formed imbedded.

Its crystals are middle sized and small.

Externally it is always smooth, and shining, which sometimes approaches to splendent. Internally it is shining, inclining to glistening.

Fracture

Fracture imperfectly flat conchoidal: sometimes with a tendency to foliated, which shews a double obliquely intersecting cleavage.

Fragments indeterminately angular and sharp edged.

Opaque.

Hard.

Pretty easily frangible.

Not particularly heavy,

Specific gravity—3,800, *Werner*—3,691, *Karsten*.

Constituent parts.

Silica	35
Alumina	6
Lime	32
Oxyd of Iron and	25
Manganese	—
	98

Vauquelin.

Geognostic Situation.

It occurs imbedded in rocks belonging to the newest floetz trap formation.

Geographic

Geographic Situation.

It has been hitherto found only in Italy, at Frefcati and St Albano near Rome.

Observations.

1. It was formerly confounded by mineralogists with garnet and shorl. To Werner we are indebted for the first accurate and satisfactory account of its external characters.

FLINT GENUS.

EIGHTH SPECIES.

Garnet.

Werner divides this species into two subspecies, the precious garnet, and common garnet.

FIRST SUBSPECIES.

Precious Garnet.

Edler Granat.—*Werner*.

Oriental garnet, *Kirw.* vol. 1. p. 258.—Edler granat, *Emm.* b. 1. f. 358. *Almandine Karst. Tab.*—Le grenat noble *Broch*, t. 1. p. 193.

External Characters.

All its colours are red, and it passes from columbine red into cherry red, and from this into a colour intermediate between cherry and blood red, and it appears even to run into brownish red. All these colours contain an intermixture of blue, but very seldom black.

It occurs very seldom massive, more often disseminated, and in original roundish grains and small pieces. It occurs most commonly crystallized, and has two principal crystallizations, viz.

1. The garnet dodecaedron.
2. The double eight-sided pyramid.
 - a. Garnet dodecaedron. This figure is either perfect, or more or less truncated on all its edges. When these truncations increase, and cause the original faces of the dodecaedron to disappear, an
 - b. Acute double eight-sided pyramid is formed, in which the lateral planes of the one are set on the lateral planes of the other, and the summits are deeply and flatly acuminate by four planes, which are conformably set on the alternate lateral edges.
 - c. The same figure as the preceding, in which the eight acute angles, formed by the meeting of the acuminate and lateral planes, and the alternate angles on the common basis, are truncated.
 - d. Rectangular four-sided prism, acuminate on both extremities by four planes, which are set on the lateral edges.

The crystals are mostly small, also middle sized, seldom large, and always all around crystallized. Surface of the crystals is sometimes smooth, particularly the planes of truncation: the planes of acuminations are sometimes diagonally streaked. Surface of the grains is rough or granulated.

Externally the crystals and grains are glistening, internally the lustre alternates from shining to glistening, bordering on splendid, and is vitreous, inclining a very little to resinous.

Its fracture is perfectly conchoidal, which often passes into imperfectly conchoidal, which again, although very rarely, verges on coarse grained uneven, and splintery: Sometimes a concealed foliated fracture, is to be observed*.

Its fragments are indeterminately angular, more or less sharp edged.

It sometimes occurs in lamellar distinct concretions.†

It alternates from completely transparent to translucent according to the kind of fracture‡.

Pretty hard. ||

Brittle.

Not particularly difficultly frangible.

Not particularly heavy, passing into heavy§.

Specific gravity.—4,230. *Werner*.—4,085, *Klaproth*.—4,352, *Karsten*.—4,188.—*Briffon*.

* Conchoidal variety has greatest, and coarse grained uneven the least lustre.

† The distinct concretions occur most frequently in that from Greenland.

‡ The transparent varieties are often impure in the middle.

|| Scratches quartz.—*Haüy*.

§ After Zircon it is the heaviest of the precious stones.

Constituent parts.

Silica	35,75
Alumina	27,25
Oxyd of Iron	36, 0
Manganefe	0 ,25
Lofs	0 ,75

 100

Klaproth, f. 2. p. 21. to 26.

Chemical Characters.

Before the blow pipe it melts pretty easily into a black enamel.

Geognostic Situation.

It occurs almost always in primitive rocks, particularly in mica slate, serpentine, chlorite slate, also in primitive mineral beds.

Geographic Situation.

It is found in Europe; in Greenland, Norway, Sweden, Scotland (in Aberdeenshire, Rosshire, and the Long Island), Saxony, Bohemia, Silesia, Switzerland,

Switzerland, Stiermark, Tirol, Hungary, Salzburg, and France. In Asia, in Armenia, Pegu, Ceylon, Siberia. In Africa, Æthiopia and Madagascar. In America, Brazils.

Use.

It is cut as a precious stone, and used for necklaces, bracelets, and rings.

Observations.

1. The oriental or precious garnet appears, from the description of Pliny, to be the carbuncle of the ancients.—*Werner.*

2. Its name is derived from its red colour, which approaches much to that of the fruit and flower of the pomegranate.

SECOND SUBSPECIES.

Common Garnet.

Gemeiner Granat.

Brown and green are its most common colours. Of brown it occurs liver brown, yellowish brown, and reddish brown; and of green, blackish green. From liver brown it passes into olive, pistacio, blackish and leek green, and from this even into mountain green: from yellowish brown it passes into isabella yellow: from reddish brown into a middle colour between hyacinth and blood red: from blackish green into greenish black.

In many specimens different colours occur together. It occurs most commonly massive, but never in grains or angular pieces. This is characteristic of it.

Sometimes crystallized, and possesses all the figures of the precious garnet, with the exception of the crystal, No. 4. They are always simply aggregated, and form druses. Seldom middle sized, commonly small, and very small.

Surface of the crystals, and particularly the dodecaedron, diagonally streaked, shining, and glistening.

Internally

Internally it is almost always glistening, seldom shining.

Lustre intermediate between resinous and vitreous.

Fracture fine grained uneven, sometimes inclining a little to the imperfectly conchoidal.

Fragments indeterminately angular, not particularly sharp edged.

It occurs in small, and fine angularly grained, distinct concretions, which sometimes pass into coarse grained.

More or less translucent, the black nearly opaque.

Not particularly hard.

Easily frangible.

Heavy in a middling degree.

Specific gravity.—3,757, 3,754, *Werner*:—3,668, *Karsten*.

Chemical Characters.

It is more easily melted than the precious garnet.

Constituent Parts.

	Wiegleb.	Merz.
Silicia	26,46	40
Alumina	22,70	20
Lime	17,91	8
Iron	16,25	20
Lofs	16,68	12
	<hr/>	<hr/>
	100	100

Voigt's Mineralog. und bergmann. Abhandlungen. Th. I, f. 15 and 22.

Geognostic Situation.

It occurs in beds in the older primitive rocks, particularly in mica slate and clay slate. It is often accompanied with different kinds of ore, as copper pyrites, iron pyrites, magnetic iron stone, lead glance, and brown blende.

Geographic Situation.

It is found in Hungary at Dognatzka, Orbitz, and Wadarna; in Bohemia, in the Bunzlauer circle; in Saxony, at the devil's stone, near Schwartzenberg; the Krebsberg, near Ehrenfriedendorf; Schneeberg, Berggieshübel, Breitenbrun and Geier. Arendal, in Norway;

Norway ; at Garpenberg, Fahlun, and Dannemora, in Sweden ; in Siberia, and many other places on the continent of Europe ; it is also found in Ireland.

Use.

On account of its easy fusibility and richness in iron, it is frequently employed as a flux in smelting rich iron ores, and as an addition to poor ores. In some countries it is named green iron ore. It is seldom cut or polished for ornamental purposes.

Observations.

1. It is distinguished from the precious garnet by colour, degree of transparency, lustre, kind of fracture, distinct concretions, druses, aggregation of crystals, specific gravity, occurring in beds, and not being imbedded.

2. Karsten considers the precious garnet as a distinct species, and names it almadine, but places the common garnet and pyrope together.

NINTH SPECIES.

Pyrope.

Pyrop.—*Werner.*

Bohemian Garnet of many mineralogists.—Precious Garnet of Karsten.

External Characters.

Its colour is dark blood red, which, when held between the eye and the light falls strongly into yellow*.

It occurs in small and middle sized roundish and angular grains, which are imbedded, but never crystallized.

Lustre splendid and vitreous.

Fracture perfectly conchoidal.

Fragments indeterminately angular and sharp edged.

Completely transparent.

Hard †.

* Pyrope and garnet, when cut and polished, are easily distinguished from spinelle and sapphire, by the dark tinge which their colours possess, *Haüy*, t. 2. p. 544.

† Scratches quartz. *Haüy.*

Not particularly heavy, approaching the heavy.
 Specific gravity—3,941, *Werner*.—3,718, *Klaproth*.

Constituent Parts.

Silica	40,0
Alumina	28,50
Magnesia	10,00
Lime	3,50
Oxyd of iron	16,50
—— of manganese	0,25
Lofs	1,25

100

Klaproth, t. 2. p 21.

Geognostic and Geographic Situation.

Occurs imbedded in serpentine at Zœblitz in Saxony, and in Wacce in the Bohemian Mittelgebirge.

In Bohemia it is most commonly found in alluvial land, which has been formed by the decomposition of the neighbouring floetz trap rocks, accompanied with crystals of sapphire and hyacinth. At the Ely in Fifeshire in Scotland, it is found in the sand on the sea shore, and is probably derived from the neighbouring floetz trap rocks.

Use.

It is employed in almost every kind of jewellery, and is generally set in a gold foil. The small and very small grains are powdered, and used in place of emery in cutting softer stones.

Observations.

This fossil used to be considered as a variety of the precious garnet, and was generally known by the name of Bohemian garnet, from its occurring in that country in great beauty and perfection. Lately, however, Werner has introduced it into the system as a distinct species, on account of its colour, transparency, and want of crystallization. The name pyrope is borrowed from Pliny and Ovid, who mention a fossil which is considered by Werner as nearly allied to the stone now known by that name.

TENTH SPECIES.

Grenatite.

Granatit.—*Werner*.

Grenatite, *Saunders*, f. 1900. *Id. Lam.* t. 2. p. 290. *Id. Brochant*, t. 2. p. 406.—*Staurotide*, *Haüy*, t. 3. p. 93.

External Characters.

Its colour is dark reddish brown.

It is always crystalized; its figure is a broad six-sided prism, in which the four broadest planes meet two and two under obtuse angles. It is sometimes bevilled, and the bevilling planes are set on the obtuser edges, which are formed by the meeting of the broader lateral planes.

Surface sometimes smooth and glistening, sometimes uneven.

The crystals are small and middle sized: are imbedded and intersect each other, either at right angles, or more or less obliquely.

Internally it is glistening, and its lustre is between vitreous and resinous.

Fracture

Fracture intermediate between small grained uneven, and imperfectly conchoidal*.

Fragments indeterminately angular.

Very often opaque, sometimes translucent, and very rarely semitransparent.

Hard †.

Brittle.

Easily frangible.

Not particularly heavy.

Specific gravity—3,286. *Haüy*.

Chemical Characters.

Infusible before the blow pipe.

Constituent Parts.

Silica	0,33
Alumina	0,44
Lime	0,0384
Oxyd of iron,	0,13
— of manganese	0,01

Vauquelin, J. d. M. N. 53. p. 453.

* Brochant remarks that it is imperfectly foliated, and that the folia are parallel with the axis; but in other directions fine grained, uneven, and sometimes conchoidal. *Broch. t. 2. p. 497.*

† Scratches quartz feebly. *Haüy*.

Geognostic

Geognostic and Geographic Situation.

It is found in St Gothard in Switzerland, imbedded in mica slate, and sometimes accompanied with Kyamite. It is also met with in Brittany in France, and in Spain near St Jacques de Compostelle.

 ELEVENTH SPECIES.

Spinelle.

Spinell.—*Werner.*

Rubinus balassus, Rubinus spinellus, *Wall.* t. 1. p. 247.—
 Rubis spinelle octaedre, *Rome d. L.* t. 2. p. 224.—Spinell,
 and balass rubies, *Kirw.* vol. 1. p. 253.—Spinell,
Esner, b. 2. f. 73. *Id. Emm.* b. 1. f. 56. & b. 3. f. 252.
 Rubino spinello, *Nap.* p. 118.—Rubis, *Lam.* t. 2. p. 224.
 Spinell, *Hauy and Brochant, Ib. Bournon, Philos. Transf.*
 1792, part 2. p. 305.

External Characters.

Its principal colour is red, from which it passes on the one side into blue, and even into green, on the other into yellow and brown. From carmine red it passes

passes on the one side into crimson, cochineal, and cherry-red, and from this into plumb, violet, and indigo blue, and into a variety of green, which is very rare *; on the other side it passes from carmine-red through blood-red into orange yellow, and from this into a middle colour between clove brown and reddish brown. It occurs also reddish white.

Its colours are mostly deep (the reddish white is the only pale colour), and they have always a shade of black. Sometimes it is enveloped in an opaline crust, sometimes it exhibits an opalescent iridescence, and others when cut exhibit stars of three and six rays †.

It occurs in grains which, from their aspect, shew that they have been rolled, also crystallized.

1. Perfect octaedron.
2. Lengthened or cuneiform octaedron.
3. When six faces of the perfect octaedron are enlarged at the expence of the other two, one in each pyramid, which at length entirely disappear, a very acute rhomboid is formed.
4. When four alternate planes of the octaedron grow large at the expence of the others, which at length disappear, a tetraedron is formed: the tetraedron is sometimes truncated on the angles, and often so deeply that only thin segments remain.

* The ceylanite of La Metherie, or pleonast of Haüy, which is here mentioned as a green coloured variety of spinelle, may possibly be found to be a subspecies of spinelle; but we have no reason for believing it to be a distinct species.

† These rayed varieties are, by Count de Bournon, referred to the oriental ruby.

5. Sometimes

5. Sometimes the edges of the common basis of the octaedron are truncated, and, in some varieties, so deeply, that a rectangular four-sided prism, acuminated by four planes, is formed*.
6. Sometimes all the edges of the octaedron are truncated. When these truncations become so large as to cause the original faces to disappear, the garnet dodecaedron is formed.
7. Sometimes each of the angles of the octaedron are acuminated by four planes, which are placed on the lateral planes †.
8. Six-sided table, in which the terminal planes are set alternately straight and oblique on the lateral planes. It may also be viewed as an octaedron, in which two diagonally opposite planes have increased very much in proportion to the others.
9. When two segments of the tetraedron are joined by their basis, a twin crystal, having three re-entrant angles, is formed.
10. When three segments are joined, a triple crystal is formed ‡.

* This variety was first described by Count de Bournon, and, as far as I recollect, does not exist in the cabinet of Werner.

† This is described by Bournon as a variety of ceylanite.

‡ Besides the crystals above enumerated, Werner mentions the following as belonging to this species: 1. Six-sided prism, having its alternate and alternating angles truncated. 2. Cube truncated on the two diagonally opposite angles. It would appear, however, from the observations of Bournon, that these varieties rather belong to the oriental ruby.

The

The crystals are small and very small, very rarely middle sized, and probably all around crystallized.

Planes generally smooth.

Externally and internally its lustre is splendid and vitreous.

Fracture nearly perfectly flat conchoidal, and sometimes imperfectly foliated.

Fragments indeterminately angular, sharp edged.

It alternates from translucent to transparent.

Hard in a high degree, but can be scratched by sapphire.

Not particularly heavy, approaching to heavy.

Specific gravity—3,700, *Werner*.—3,645, *Haüy*.—3,570, *Klaproth*.

Chemical Characters.

Before the blow pipe it is unalterable without addition, but is fusible with borax.

Constituent Parts.

Alumina	74,50	82,47
Silica	15,50	
Magnesia	8,25	8,78
Oxyd of iron	1,50	
Chromic acid		6,18
Lime	0,75	
Lofs		2,57
	<hr/>	<hr/>
	100,50	100

Klaproth, t. 2. p. 10.*Vauquelin*, *J. d. M.*
N. 38. p. 89.*Geognostic Situation.*

Werner is of opinion that it occurs in rocks belonging to the newest floetz trap formation. In the magnificent collection belonging to the Honourable Mr Greville are two interesting specimens which, although they do not enable us to ascertain the repository of the spinelle, make us acquainted with some of its accompanying fossils. In one of the specimens crystals of spinelle are imbedded in calcareous spar, and accompanied with crystals of mica, magnetic pyrites, and a substance which Count de Bournon believes to be asparagus stone: in the other the spinelle is

is imbedded in adularia, and is accompanied with magnetic pyrites *.

Geographic Situation.

It is found in the kingdom of Pegu, and in the island of Ceylon, accompanied with zircon, hyacinth, tourmaline, and ceylanite. *Bournon.*

Use.

It is employed as a precious stone, and is of considerable value, but it has neither the hardness nor the fire of the oriental ruby. *Some specimens are valued next to true rubies - It is improved by heating in the fire.*

Observation.

When spinelle and oriental ruby of the same colour are cut, we can distinguish them from each other by the superior hardness, and greater specific gravity of the latter,

* The reader is referred to Count de Bournon's very excellent Memoir on Corundum for a more particular account of these specimens.

Handwritten note: Distinguish this mineral if possible from the spinelle

TWELFTH SPECIES.

Sapphire.

Saphir.—*Werner*.

Saphirus, *Wall*, t. 1. p. 248.—Rubinus orientalis, *Ibid*. p. 247.—Topazius orientalis, *Ibid* p. 251.—Rubis d'orient, *R. de L.* t. 2. p. 212.—Oriental ruby, sapphire, and topaz, *Kirw.* t. 1. p. 250 —Saphir, *Fstner*, b. 2. f. 86. *Id. Emm.* b. 1. f. 67. & b. 1. f. 251.—Zaffiro et rubin-zaffiro, *Nap.* p. 113. & 121.—Saphir, *Broch.* t. 1. p. 207.—Felsie, *Haüy.* t. 2. p. 480 —Perfect corundum, *Greville and Bournon.* *London Philos. Transf.* 1798 & 1802.

External Characters.

Its principal colour is Berlin blue; but it occurs also red, and of all the intermediate varieties that exist between these two principal colours. It passes on the one side into indigo blue, on the other into azure, violet, lavender, lilac, and sky blue, and further into deep green; from the lilac blue it passes into peach-blossom red, crimson red, cochineal red, and very rarely into carmine red; from the peach-blossom red it passes into rose red and reddish white; it has been also

also observed yellowish white, and lastly it passes from lavender blue into pearl grey, blueish grey, and blueish white.

Werner supposes that the yellowish white may pass into yellow.

It is sometimes found with two colours at once, as white and blue and blue and red. Werner has in his possession a sapphire which is white in the middle, and at the one end blue and at the other red.

It occurs in small rolled pieces, and crystallized. Its crystallizations are as follows :

1. Double three-sided pyramid, in which the lateral planes of the one are set on the lateral edges of the other ; or it may be considered as a slightly acute rhomboid.
2. The extremities of the pyramids (or the two diagonally opposite angles of the rhomboid) more or less deeply truncated, and sometimes so deeply that there is formed a six-sided table, in which the terminal planes are set alternately oblique and straight on the lateral planes.
3. Sometimes the common basis of the pyramids is truncated, and in some varieties so deeply, that there is formed a rhomboidal six-sided prism acuminated by three planes, which are set on the alternate lateral edges. The extremities of the acuminations are often truncated.
4. Perfect six-sided prism, which is sometimes so short that it forms a six-sided table.
5. Six-

5. Six-sided prism truncated on the lateral and terminal edges, and on the alternate angles.
6. When the truncations on the terminal edges increase there is formed a six-planed acuminations.
7. When the prism of the preceding figure disappears, a more or less acute double six-sided pyramid is formed. The extremities of the pyramid are usually more or less deeply truncated; sometimes truncated on the alternate angles which are formed by the meeting of the truncating plane and the acuminating planes, and very rarely with unaltered extremities.
8. More or less acute single six-sided pyramid, in which the extremity is usually truncated, and sometimes even the edges. In some rare varieties the alternate angles, formed by the meeting of the truncating plane and the acuminating planes, and also the alternate angles of the basis are truncated.
9. Single six-sided pyramid flatly acuminated by three planes, which are set on the alternate lateral edges.

Crystals small and middle sized, and all round crystallized. The planes of the crystals are often transversely streaked, and, when fresh, are generally splendid.

Internally its lustre is splendid and vitreous.

Fracture

Fracture conchoidal in true sapphire*; in those varieties which are denominated oriental ruby it presents a three-fold oblique angular cleavage, which is parallel with the sides of the rhomboid.

Fragments indeterminately angular.

It is more or less transparent, even sometimes passing to translucent, and there are varieties that, when cut, and exposed to the rays of the sun, exhibit a star of six rays.

Hard in the highest degree, resisting the file, but yielding to the diamond.

Easily frangible.

It is heavy.

Specific gravity—From 3,980 to 4,180, *Werner*.—3,994 to 4,283, *Haüy*.—4,000, *Kirwan*.—From 4,000 to 4,083, *Hatchett & Greville*.—3,907 to 4,161, *Bournon*.

Constituent Parts.

Silica	0	35,0
Alumina	98,5	58,0
Lime	0,5	5,0
Oxyd of iron	1,0	2,0
	<hr/>	<hr/>
	100	100

Klaproth, t. 1. p. 88.

Bergman.

* Count de Bournon is of opinion that a three-fold cleavage is to be observed in sapphire.

Sapphire.

Sapphire.		Oriental ruby.
Silica	5,25	7,0
Alumina	92,0	90,0
Iron	1,0	1,2
Lofs	1,75	1,8
	<hr/>	<hr/>
	100,00	100,00
	<i>Genevix.</i>	<i>Id.</i>

Chemical Characters.

It is infusible without addition before the blow pipe; but with borax it melts without effervescence.

Geognostic Situation.

Werner suspects that it occurs in rocks belonging to the newest floetz trap formation: and it would appear, from the observations of the Hon. Mr Greville and Count de Bournon, that it is also an inmate of granite, syenite, and other primitive rocks.

Geographic Situation.

It is found particularly beautiful in the kingdom of Pegu and island of Ceylon in the East Indies. It has been also discovered in Portugal; France, in the stream Expailly; also in Bohemia near Meronith and Bilin,
at

at the foot of trap rocks, and accompanied by hyacinth, pyrope, and iron sand.

Use.

Sapphire and oriental ruby are, next to the diamond, the most valuable of precious stones, and are used in the finest kind of jewellery. *Seen only by the eye, more precious - The paler kind are called blue seen by Jerusalem - It has a name of Jordan - why may be named to one day be taken it +*

Observations.

1. Werner is of opinion that sapphire and spinelle are very nearly allied, and that in some instances spinelle passes into sapphire.

2. The oriental ruby, which is here arranged, in conformity to the method of Werner, along with the sapphire, appears, from the observations of Count de Bournon, to be a distinct species.

It differs from sapphire in its colour suite, in having a distinct foliated fracture, in being softer and possessing less specific gravity; and in its geognostic character, as it occurs sometimes imbedded in corundum, which is an inmate of primitive mountains, while sapphire appears to be more a production of a later period.

3. The violet coloured sapphire is the oriental amethyst; the yellow, the oriental chrysolite and topaz; and the green, the oriental emerald.

~~to be cavity is however than the rest~~

It is found in the banks of the Green - which is supposed to be a species of

THIRTEENTH SPECIES.

Corundum.

Korund.—*Werner.*

Ib. Wid. f. 237.—Adamantine spar, *Kirw. vol. 1. p. 335.*
 =Demant spath, *Emm. b. 1. f. 9. & b. 3. f. 229.*—
 Spato adamantino, *Nap. p. 223.*—Corindon, *Lam. t. 2.*
p. 356.—Le spath adamantine, *Broch, t. 1. p. 356.*—
 Corindon, *Haüy. t. 3. p. 1.*—Imperfect corundum, *Gre-*
ville and Bournon. Philos. Transf. 1798 & 1802.

External Characters.

Its colour is greenish white of various degrees of intensity, which passes into light greenish grey, and even into mountain and asparagus green; it is sometimes also pearl grey, which passes into flesh red, and in some varieties it is reddish externally, but greenish internally.

It occurs massive, disseminated, in rolled pieces, and crystallized. Its crystallizations are similar to those of sapphire.

The crystals are middle sized and imbedded.

Externally they are dull and rough.

The

The lustre of the principal and cross fracture is shining and glistening, and is intermediate between vitreous and resinous.

The fracture is foliated, with a three-fold obliquely intersecting cleavage, and the cleavages are parallel with the planes of the rhomboid, or of the alternate angles of the six-sided prism: cross fracture is small and imperfectly conchoidal.

Fragments rhomboidal.

It shews a tendency to straight lamellar distinct concretions.

It is duplicating translucent.

Hard in a high degree, yielding a little to the file*.

Pretty easily frangible.

Not particularly heavy, approaching to heavy.

Specific gravity—3,710, *Klaproth*.—3,873, *Hayy*.—3,875, *Bournon*.

Constituent Parts.

Corundum of the Carnatic.		Of Malabar.
Silica	3,0	7,0
Alumina	91,0	86,5
Iron	1,5	4,0
Loss	2,5	2,5
	<hr/>	<hr/>
	100	100

According to *Chenevix*.

* Scratches quartz. *Hayy*.

Corundum of Bengal.

Alumina	89,50
Silica	5,50
Oxyd of iron,	1,25
Lofs	3,75

According to *Klaproth*.

Geognostic Situation.

It probably occurs imbedded in granite, sienite, or greenstone, as the crystals of it are often found in a rock composed of felspar, quartz, hornblende, and mica.

Geographic Situation.

It is found in the Carnatic and on the coast of Malabar.

It is also found in the Carnatic and on the coast of Malabar. It is also found in the Carnatic and on the coast of Malabar. It is also found in the Carnatic and on the coast of Malabar.

FOURTEENTH SPECIES.

Diamond spar.

Demant spath.—*Werner*.

External Characters.

Its colour is dark hair brown.

It occurs massive, disseminated, in rolled pieces, and crystallized in

1. Six-sided prisms, and in
2. Simple very acute six-sided pyramids, having their extremities truncated.

Internally its lustre is splendid, and generally pearly, approaching in a slight degree to adamantine. When cut into a semicircular shape, and in such a manner that the point of intersection of the three-fold cleavage occupies the middle of the surface, it presents an opalescent star of six rays, and a peculiar pearly light, which is of a copper red colour.

Fracture presents a perfect obliquely intersecting three-fold cleavage.

Fragments rhomboidal, but not so perfect as in corundum.

It is translucent on the edges.

Hard

Hard in a high degree, yielding a little to the file.
Easily frangible.

It is not particularly heavy, approaching to heavy.
Specific gravity—3,981.

Constituent Parts.

Diamond spar of China.	
Alumina	84,00
Silica	6,50
Oxyd of iron	7,50
Loss	2,0

100,0

According to *Klaproth*.

Geognostic Situation.

Probably occurs in granite.

Geographic Situation.

Has been hitherto found only in China.

Use.

Use.

Both diamond spar and corundum are employed in cutting and polishing hard minerals.

Observations.

1. The great hardness of corundum and diamond spar, independent of their strong affinity to sapphire, may be considered as justifying their removal to the flint genus.
2. The compact corundum of Bournon is probably only a variety of the following species.
3. It is probable that diamond spar is only a variety or subspecies of corundum.

FIFTEENTH SPECIES.

Emery.

Schmiergel.—*Werner*.*External Characters.*

Its colour is intermediate between greyish black and blueish grey.

It occurs massive and disseminated; and the massive is sometimes intermixed with other minerals.

Its lustre is glistening, passing into glimmering, and is adamantine.

Fracture fine and small grained uneven; sometimes even splintery.

Fragments indeterminately angular, rather blunt edged.

It sometimes shews fine grained distinct concretions.

Is slightly translucent on the edges:

Hard in a high degree, scarcely yielding to the file.

Not very easily frangible.

Heavy.

Constituent Parts.

Alumina	86,0
Silica	3,0
Iron	4,0
Lofs	7,0

 100

According to *Tennant, Philos. Transf. for 1802.*

Specific Gravity is about 2'00 —

Geognostic Situation.

It occurs in beds of talc and steatite, and is frequently accompanied with calcspar and blende.

Geographic Situation.

It is found at Ochsenkopf near Schwartzenberg in Saxony; also in great quantity in the islands of the Hellepontic Archipelago, particularly in the island of Naxos. It is said also to occur in the isles of Guernsey and Jersey, on the coasts of Normandy, and in Spain.

Use.

It is used for cutting and polishing hard bodies ; it is even employed for cutting sapphire and oriental ruby.

Observations.

1. Its high degree of hardness, and affinity to corundum, have induced me to give it its present place in the system.

2. May not this, and the four preceding species, be arranged in the following order?

Ruby Family.

Spinelle.

Sapphire.

a. Sapphire.

b. Oriental ruby.

Corundum.

a. Common corundum.

b. Diamond spar.

c. Emery, or compact corundum.

3. Magnetic iron stone, and iron glance, from their being employed in place of emery in polishing hard bodies, have been confounded with it.

SIXTEENTH SPECIES.

Topaz.

Topaz.*—*Werner*.

Topazius octaedricus prismaticus, *Wall.* t. 1, p. 251.—
 Topaze du Brezil, *R. d. L.* t. 2. p. 230.—Topaze de
 Saxe, *Ibid* p. 260.—Topaz. *Wern. Cronst.* p. 97.—*Ibid.*
Wid. p. 267.—Occidental Topaz. *Kirw.* vol. 1. p. 254.
 —Topaz. *Estner*, b. 2. f. 98. *Id. Emm.* b. 1. f. 374.—
 Topazio, *Nap.* p. 136.—Topaze du Brezil, de Saxe et
 de Siberie, *Lam.* t. 2. p. 254.—*Ibid. Broch.* t. 1, p. 212.
Ib. Haüy, t. 2. p. 504.

External Characters.

Its principal colour is wine yellow, of all degrees of intensity. It passes from the pale wine yellow into yellowish white, and yellowish grey, and from this into greenish white and mountain green, and into a middle colour between mountain green and feladon green, and even into sky blue. From the deep wine yellow it passes into flesh red, and from this into crimson red, which borders on lavender and lilac blue. This latter variety is very rare.

* The name Topaz is derived from Topazos, a small island in the Red Sea, where it is said the Romans used to collect this stone.

It occurs massive, disseminated, sometimes in rolled pieces, but most commonly crystallized.

Its crystallizations are as follows.

1. Oblique eight-sided prism, having four larger and four smaller lateral planes, of which always two and two meet under very obtuse angles; or it may be viewed as an oblique four-sided prism, with the two obtuse edges, more or less deeply and obtusely bevelled.
2. Oblique, four-sided prism, which presents the following varieties.
 - a.* Acuminated by four planes which are set on on the lateral planes.
 - b.* The angles which the acuminate planes make with the lateral planes on the acute lateral edges, more or less deeply truncated.
 - c.* The four planed acuminations again acuminated.
 - d.* The double acuminations again acuminated; this forms a triple acuminations.
 - e.* When the truncation of the angles, which the acuminate planes make with the lateral planes on the acute lateral edges increase, a six-planed acuminations is formed.
 - f.* Sometimes the angles of the obtuse lateral edges are truncated.
 - g.* Sometimes the angles on the acute lateral edges (*b*) are a second time truncated,
 - h.* Frequently the summit of the six-planed acuminations is more or less deeply truncated

and this gives us the crystalline figure of the Saxon topaz, which may be described as an oblique, four-sided prism, having its terminal and obtuse lateral edges bevelled, and the acute angles truncated, and the three angles which lay around the truncating planes, also truncated.

When the truncations of the acute angles increase, a bevillment is formed, and then little remains of the other bevilling planes: often also the obtuse lateral edges are more or less deeply bevelled, and thus is formed an eight-sided prism.

The Brazilian topaz generally occurs with acuminations, but without truncations; the Siberian on the contrary is usually bevelled.

The lateral planes are deeply longitudinally streaked, but the other planes are smooth.

The Brazilian and Siberian topaz is more deeply streaked than the Saxon.

The crystals are small and middle sized, very seldom large, commonly implanted (aufgewachsen) and in druses.

Externally it is splendid, internally splendid and shining; lustre vitreous.

Cross fracture perfectly straight foliated; the longitudinal small and imperfectly conchoidal.

Fragments indeterminately angular and sharp edged, sometimes tabular and splintery.

Alternates from translucent to transparent, and is duplicating transparent.

It is the most peculiar among all topaz, and it is very frequently seen in the **Hard**

The massive occurs in coarse and fine grained distinct concretions.

Hard in a high degree yielding a little to the file.*

Easily frangible.

Intermediate between not particularly heavy, and heavy.

Specific gravity — 3,464 to 3,556 *Werner*. — 3,556 to 3,564, *Haüy*. — 3,540 to 3,576, *Karsten*.

Chemical Characters.

Saxon topaz in a gentle heat turns white,† but a strong heat deprives it of lustre and transparency: the Brazilian, on the contrary, by exposure to a high temperature burns rose red,‡ and in a still higher, violet blue. Before the blow pipe it is scarcely fusible, but exposed to a steam of oxygen gas it soon melts into a porcellanous bead. It is fusible with borax, but alkali has little effect on it.

Physical Characters.

The topaz of Brazil, Siberia, and Mucla in Asia Minor, when heated exhibit at one extremity positive, and the other negative electricity. The Saxon, by friction, gives signs of electricity.

* It cuts quartz, but is cut by ruby.—*Haüy*.

† When thus altered the Saxon topaz is sometimes sold for diamond.

‡ Topaz thus altered is cut and sold by jewellers under the name of Brazilian ruby and pale spinelle.

Constituent Parts.

Silica	31	39
Alumina	68	46
Lofs	1	
Lime		8
Iron		6
	100	99

Vauquelin, *I. d. M.* No. 24,
p. 4. It is Saxon topaz.

Bergmann *Opusc.* vol. 2.
p. 96.

Geognostic Situation.

It is found in veins, that traverse primitive rocks, accompanied by fluor spar, tin ore, and arsenical pyrites; but its most peculiar repository is in that kind of rock, denominated by Werner topaz rock, which is an aggregate of topaz, quartz, and schorl, having in the small a flaty, but in the great a granular texture. The Siberian is found accompanied with beryl, in that variety of granite which has received the fanciful name of Pierre Graphic.

Geographic Situation.

It is found in Brazil, in Siberia among the Uralian mountains, particularly at Adon-Tschelon in Nertsch-
insk

insk; the beautiful rose red variety at Mukla in Lesser Asia, where it was discovered by an intelligent traveller, our countryman Mr Hawkins: also in Pegu and Ceylon. In Europe, in Bohemia at Schlackenwald, Zinnwald and Heinrichgrün; in Saxony at Scheckenstein, Altenberg, Zinnwald, Eibenstock, Ehrenfriederdsdorf and Geier; in Cornwall in England

Observations.

1. When colour was considered as affording the most certain means of distinguishing the precious stones from each other, many different fossils were associated with the topaz; and varieties of topaz were described as distinct species. Thus the yellowish white sapphire was termed oriental topaz, yellowish rock crystals Bohemian or occidental topaz; chrysolite was also considered as a variety of topaz: on the other hand, the greenish varieties of topaz were named aqua marine, and the blue, sapphire.

2. The topaz of the ancients is considered by Werner to be our chrysolite.

3. The Saxon topaz is reckoned by jewellers to have the most fire.

4. In the collection of the museum of natural history at Paris, there is a Brazilian topaz which weighs 4 ounces 2 gros.

SEVENTEENTH SPECIES.

Emerald.

Schmaragd.—*Werner*.

Gemma pellucidissima. Smaragdus, *Wall.* t. 1, p. 253.—
 Emeraude du Perou, *R. d. L.* t. 2. p. 245.—Schmar-
 agd. *Wern. Cronst.* p. 102. *Ib. Wid.* p. 271.—Emerald,
Kirw. vol. 1. p. 247 —Smaragd. *Efner.* b. 2. p. 132.—
 Smeraldo, *Nap.* p. 122. *Lam.* t. 2. p. 227. *Brochant.*
 t. 1. p. 217.—Emeraude, verte *Hauy.* t. 2. p. 516.

External Characters.

Its characteristic, and, we might almost say, its only colour, is emerald green, of all degrees of intensity, from deep to pale. The deep sometimes inclines a little to verdegriis green, and sometimes, and oftener, to grass green: the pale varieties sometimes nearly pass into greenish white.

It is said to occur massive, and in rolled pieces, but of such *Werner* has seen no specimens; he has only observed it crystallized in

Low, equiangular, six-sided prisms, which are 1st, perfect; 2d, truncated on the lateral edges;

3d, truncated on the terminal edges ; 4th, truncated on the terminal angles ; 5th, terminal edges bevilled. When the truncations on the lateral edges increase, a twelve-sided prism is formed.

Crystals middle sized and small, very rarely large ; always implanted, and in druses.

Lateral planes smooth, terminal planes rough.

Internally the lustre is intermediate between shining and splendid, and is vitreous.

Fracture small and imperfectly conchoidal, yet it sometimes exhibits a concealed foliated fracture, having a fourfold cleavage, of which the folia are parallel with the lateral and terminal planes, as is the case with beryll.

Fragments indeterminately angular, and more or less sharp edged.

Alternates from transparent to translucent, and is duplicating transparent.

Hard, and little more than quartz, which it scratches with difficulty.

Not particularly heavy.

Specific gravity—2,600, *Werner*.—2,775, *Brisson*.—2,7227 to 2,7755.—*Haüy*.

Chemical Characters.

Before the blow pipe it is difficultly fusible, but melts easily with borax.

Constituent Parts.

Silica	64,50	69
Alumina	16	15
Glucine,	13	12,50
Oxyd of Chrome	3,25	25
Lime	1,60	25
Water	2	Oxyd of Iron 1
	<hr/>	<hr/>
	100,35	97,90
	<i>Vauquelin.</i>	<i>Klaproth.</i>

I. d. M. N. 38, p. 98.

Geognostic Situation.

It occurs in veins that traverse clay slate*. The accompanying fossils are calc spar, felspar, quartz and iron pyrites. *Calc spar*

Geographic Situation.

At present it is only found in South America, and there principally in the mountains of Popayan, and in the neighbourhood of de Manta, near to Puerto-Viejo, in Peru. The Romans are said to have procured it from Æthiopia and Egypt.

* Clay slate is usually known by the name primitive slate. Werner, for reasons which will be stated in the Geognostic, abolished the term primitive slate.

Uſe.

The colour which characteriſes this foſſil is extremely pleaſing ; the eye, after viewing the beautiful colours of the ſapphire, oriental ruby, ſpinelle and topaz, reposes with delight on the freſh and animating colour of the emerald, the charming emblem of the vegetable kingdom ! It is rare, however, to find the colour pure and of good ſtrength, hence ſuch ſpecimens are very highly valued, and are employed in the moſt expenſive kinds of jewellery.

Observations.

1. Emerald and beryll have a ſtrong reſemblance to each other ; thus both are green, their cryſtallization differs but little, and fracture, hardneſs and weight are nearly the ſame. Notwithſtanding theſe agreements, Werner conſiders them as well diſtinguiſhed from each other by the following characters : Emerald occurs only green, but beryll beſides green is alſo yellow and blue ; the cryſtals of beryll are long, thoſe of emerald are ſhort ; the lateral planes of beryll are ſtreaked, thoſe of emerald are ſmooth ; the terminal planes of beryll are ſmooth, thoſe of emerald are rough ; beryll often preſents diſtinct concretions, emerald never ; beryll often ſhews a formation by acicular ſhoots, emerald never ; beryll has tranverſe rents, emerald never.

2. Many

2. Many of the emeralds described by the ancients appear to have been varieties of green fluor spar; even in more modern times, fluor spar has been preserved for emerald. Mr Coxé examined the famous emerald table in the abbey of Reichenau near Constance, which he found to be a very fine green coloured fluor spar. The famous sacro cattino di smeraldo orientale, preserved at Genoa, and which could only be seen by an order from the senate, appears to be made of cellular glass. Many fine Æthiopian emeralds, which were bequeathed to monasteries, appear to have been sold by the monks, and coloured glass substituted in their place.

3. Several mineralogists are of opinion that the true emerald was not known in Europe until after the conquest of Mexico and Peru by the Spaniards. The following facts, however, are in opposition to this conjecture. 1. In the mitre of Pope Julius the Second, which is now preserved in the museum of natural history at Paris, there is a fine deep coloured emerald: as he died in 1513, and Peru was not discovered and conquered by Pizarro before 1545, it is highly probable that this emerald was brought from Africa. 2. Werner has in his possession several antique emeralds, and Mr Hawkins informed the Abbe Estner that he had seen a necklace of emeralds, which was found among the ruins of Portici near Naples.

4. The Brazilian emerald is a variety of tourmaline.

5. It is one of the lightest and softest of the precious stones.

As Werner says, it is found in grains, but he does not suppose his opinion EIGHTEENTH

EIGHTEENTH SPECIES.

Beryll.

Berill.—*Werner*.

Werner divides this species into two subspecies.

FIRST SUBSPECIES.

Precious Beryll.

Edler Beril.—*Werner*.

Smaragdus—Aqua marina et Smaragdus—Berillus. *Wall.*
 t. 1. p. 254.—Aigue marine de Sibirie, *R. d L.* t. 2.
 p. 252. *Ibid. Born.* t. 1. p. 71.—Edler Beril. *Wern.*
Cronst. f. 100.—Beryl. *Kirw.* vol. 1. p. 248.—Ed. Beril.
Wid. f. 274.—*Id. Esner,* b. 2. f. 197.—Berillo *Nap.*
 p. 125. *Id. Lam.* t. 2. p. 232.—Le Beril noble, *Broch.*
 t. 1. p. 220.

External Characters.

Its principal is green, from which it passes on the one side into blue, and on the other into yellow. It is

is commonly mountain and feladon green: from these it passes through apple green, asparagus green, into oil green, and lastly into honey yellow, which approaches to wine yellow. From the feladon green it passes into smalt, sky, and, in rare instances, into azure blue. *Berline Blue*

Almost all its colours are pale, seldom deep, and scarcely ever dark. Sometimes it has two colours at once, which alternate in layers, and sometimes it is iridescent.

It is crystallized in long equiangular six-sided prisms, which are either perfect or truncated on the lateral and terminal edges and angles. The truncations of the terminal edges sometimes become so large as to form six-planed acuminations, of which the apices are truncated. The crystals, owing to the different breadths of their lateral planes, sometimes approach to trihedral, sometimes to oblique tetrahedral prisms. When they have cylindrical, convex lateral planes, they are sometimes acicular, sometimes reed-like.

The crystals are sometimes heaped on each other, the smaller ones being almost always uppermost, thus forming a shape like a tower; and, in other cases, they are perforated in the direction of their axes.

Imbedded and implanted, and intersect one another, but are seldom single.

Deeply longitudinally streaked, but the truncating and terminal planes smooth.

Small, large, and very large.

Externally

Externally its lustre is shining and glistening; internally shining, which sometimes passes into glistening and splendid, and is vitreous.

Cross fracture intermediate between uneven and small, and imperfectly conchoidal; longitudinal fracture foliated with a fourfold cleavage: three of the folia or cleavages are parallel with the lateral planes, and the fourth with the terminal planes; and the lateral and terminal cleavages generally intersect each other at right angles. The cleavage is often very imperfect.

Fragments indeterminately angular, more or less sharp edged.

The massive is composed of straight and thin columnar prismatic distinct concretions, which are formed by collections of prisms disposed in different directions.

Commonly transparent, but sometimes passes into translucent, and is slightly duplicating. The translucent variety has cross rents.

Hard: scratches quartz; nearly equal in hardness to topaz, with which the mountain green variety has been often confounded.

Easily frangible.

Not particularly heavy.

Specific gravity.—26,500 to 27,590, *Werner*.—2,683 to 2,722, *Briffon*.

Chemical Characters.

Before the blow pipe it is difficultly fusible without addition, but with borax it melts easily.

Constituent parts.

Silica	69,50	68,0
Alumina	14,00	15,0
Glucine	14,00	14,0
	Lime	2,0
Oxyd of Iron	11,00	1
	<hr/>	<hr/>
	98,0	100

Rese. Vauquelin, I. d. M.
N. 43, p. 563.

Physical Character.

It becomes very electrical by rubbing.

Geognostic Situation.

It occurs imbedded in primitive rocks, also in veins. It is usually accompanied with quartz, felspar, garnet, mica, fluor spar, and topaz. At Schlackenwald it

Q.

occurs.

occurs in veins along with tin stone, quartz, and steatite.

Geognostic Situation.

The most beautiful berylls are brought from Dauria on the frontiers of China, and the Brazils. They are also found in the Uralian mountains; in France, (where they have been considered as emerald) and in Saxony at Johannegeorgenstadt. I saw in the cabinet of the Hon. Mr Greville, a six-sided prism of beryll, which he was told had been found in the upper part of Aberdeenshire in Scotland.

Uses.

When pure it is cut for ring stones and for necklaces. Its frequency, inferior hardness, and little fire, render it, however, of less value than many other of the precious stones.

Observations.

Hauy and Karsten from the emerald and precious beryll agreeing in crystallization and constituent parts, consider them as varieties of the same species, but we have already shewn the fallacy of this opinion.

2. Beryll seldom or never contains chrome, hence it does not shew the fine emerald green colour which characterises the emerald.

3. It was well known to the ancients, who procured it from several places where it is at present found. Pliny has given a good account of it, yet in latter times his description appears to have been forgotten, for we find it arranged with other precious stones, to which it had but little resemblance; thus the blue varieties were denominated sapphire, the green, aqua marine, and the yellow, topaz. About fifteen years ago, Werner obtained a complete suite of specimens of this fossil from Siberia, which enabled him to frame the preceding description, and to settle it as a distinct species.

Handwritten notes:
The above is a species of Beryll...
which the ancients called...
All specimens are seen crystals of distinct
length & 4 or 5 inches in thickness.

Faint handwritten text, mostly illegible.

Faint handwritten text, mostly illegible.

SECOND SUBSPECIES.

Schorlous beryll.

Schörlartiger berill.—*Werner*.

Weisser Stangenschoerl, *W. Cronst.* p. 169.—Schorl blanc prismatique, *R. d. L.* t. 2, p. 420.—Schörlartiger berill, *Wid.* p. 276.—Shorlite, *Kirwan.* vol. 1, p. 286. *Estner.* b. 2. p. 207.—Sorlo bianco, *Nap.* p. 152.—Lucolite, *Lam.* t. 2, p. 274.—Leucolite, et Pycnite, *Hauy,* t. 3, p. 236.—Le Beril schorliforme, *Broch.* t. 1, p. 124.

External Characters.

Its principal colour is straw yellow, which passes into yellowish white, greenish white, asparagus green, and sulphur yellow. Some varieties possess a colour which is intermediate between peach blossom and rose red, and it even verges on crimson red: other varieties, as those from Altenberg in Saxony, are marked with spots of a violet blue, which inclines to cherry red.

It occurs almost always massive, and crystallized in long six-sided prisms, (which are probably truncated

on

on the terminal edges), generally imbedded and seldom disengaged.

Crystals large and middle sized.

Externally and internally its lustre is shining, approaching to glistening and is resinous.

Cross fracture imperfectly foliated; the longitudinal fracture small and imperfectly conchoidal.

Fragments indeterminately angular.

Composed of parallel, thin, and straight prismatic distinct concretions, which are longitudinally streaked.

More or less translucent.

Hard in a middling degree, yielding to the file.

Brittle.

Uncommonly easily frangible.

Not particularly heavy, approaching to heavy.

Specific gravity.—3,530, *Klaproth*.—3,514, *Haüy*.

Chemical Characters.

Before the blow pipe it is infusible without addition; with borax it melts into a pure transparent glass.

FLINT GENUS.

Constituent Parts.

Silica	46	50	36,8
Alumina	52	50	52,6
		Lime	3,3
Water	2		1,5
	<u>101</u>	<u>100,0</u>	<u>94,2</u>

Bergman. Crells. Annal. *Klaproth.* *Vauquelin.*
 1784. *Ibid.* 1788.

Geognostic Situation.

It is found imbedded in a bed composed of quartz and mica, and probably also in gneufs.

Geographic Situation.

It is found in considerable quantity at Altenberg in Saxony, Schlackenwalde in Bohemia,; also in Moravia, where it occurs imbedded in gneufs, and accompanied with lepidolite; and at Rabenstein in Bavaria*.

*Flurl's Bavaria, p. 252.

Observations.

It was for several years considered to be a variety of schorl, and was named white prismatic schorl by some, and schorlite by others. Werner discovered that it was a distinct fossil, but so nearly allied to precious beryll as to form a subspecies, which he named schorlous, from its strong resemblance to schorl. It is placed immediately before schorl, as it is the link which unites it with beryll.

2: The reddish coloured variety of Moravia was for some time considered to be crystallized lepidolite.

*Crystals of this variety were
with Bichman's description at one of the mines*

NINETEENTH SPECIES.

Schorl.

Schörl.—*Werner*.

Werner divides this species into two subspecies :

1. Common schorl.
2. Tourmaline.

FIRST SUBSPECIES.

Common Schorl.

Gemeiner Schörl.—*Werner*.

Some of the varieties of basaltic crystallization, *Wall*, t. 1, p. 333.—Schwartzstein-schorl, *Wid.* p. 279.—Schorl, *Kirw.* vol. 1. p. 265.—Sorlo-nero, *Nap.* p. 146.—Tourmaline, *Lam.* f. 2. p. 295.—Le schorl noire, *Broch.* t. 1. p. 226.—Tourmaline noire.—*Haüy*, t. 3. p. 31.

External Characters.

Its colour is velvet black, of various degrees of intensity.

It occurs often massive and disseminated, seldom in rolled pieces, and frequently crystallized.

Its crystals are three-sided prisms, with cylindrically convex lateral planes, and acuminate on both ends by three planes, which, on the one extremity are set on the lateral edges, on the other, on the lateral planes.

The crystals are mostly acicular: often also broken, forming with the fragments a peculiar kind of fragment stone or breccia: and are imbedded. The lateral planes are longitudinally streaked, and alternate from shining to glistening.

R

Internally

Internally its lustre is intermediate between shining and glistening, and is vitreous.

Its fracture is intermediate between imperfectly conchoidal, and small and coarse grained uneven, and inclines sometimes more to the one, sometimes more to the other.

Fragments indeterminately angular.

It very rarely presents coarse and small grained distinct concretions; sometimes it occurs in very thin, thin, and but seldom in thick and straight prismatic distinct concretions. These concretions are sometimes so thin that they verge on the fibrous, and such varieties are sometimes parallel, but most frequently scopiformly divergent, and are sometimes again collected into thick wedge-shaped concretions, which rarely pass into coarse and small grained distinct concretions.

Opaque, but a little translucent on the edges, when it passes into tourmaline.

Gives a grey streak.

Hard, slightly inferior to quartz.

Very easily frangible.

Intermediate between not particularly heavy, and heavy.

Specific gravity—3,092, *Brissou*. — 3,150, *Gerhard*. — 3,212, *Kirwan*, *Sp.*

Chemical Characters.

Before the blow pipe it melts pretty easily without addition into a blackish slag. Melted with borax it forms a greenish coloured glass.

Constituent

Constituent Parts.

		Maffive.	Cryftallized.
Silica	33,33	40	38
Alumina	40,83	25	20
Iron	20,41	Lime	15
Manganefe	3,33	Oxyd of iron with Manganefe	18
	97,90	98,0	97,0

Wieglib. Crells Beit-
räge, b. I. 333.

Gerbard, Deffen Grund. einer neu-
en *Min. Syft.* th. I. f. 312.

Physical Characters.

By heating it exhibits positive electricity at one extremity, and negative at the other. Wiedenman remarks that when it begins to cool, the positive end becomes negative, and the negative positive.

Geognostic Situation.

It occurs in primitive rocks, principally in quartz and granite; with the former it constitutes a peculiar mountain rock*. It is found feldomer in gneufs, and

* The natural history of the fchorl rock will be detailed in that part of this work which treats on mineralogical geögraphy.

still feldomer in mica slate and clay slate. It occurs also in single beds, and veins of the oldest formation, particularly tin veins.

Geographic Situation.

It is found in many places of Saxony, Bohemia, Bavaria, Switzerland, Spain, Hungary, Scotland, &c.

Observations.

1. It has been confounded with basaltic hornblende, melanite, actynolite, tremolite, beryll, &c.
2. It was first found near the village of Schorlaw, in Saxony, whence it s name.
3. It differs from tourmaline in colour, degree of lustre, fracture, transparency, and distinct concretions; also in its geognostic situation, for tourmaline occurs almost always imbedded and in single crystals; on the contrary, schorl is usually aggregated, and occurs in beds.

SECOND SUBSPECIES,

Tourmaline.

Tourmalin.—*Werner*.

Zeolites—Electricus turmalin, *Wall.* t. 1. p. 329.—Schorl transparent rhomboidal, *R. d. L.* t. 2. p. 344.—Brasilianischer turmalin, *Wid.* p. 284.—Tourmaline, *Kirw.* t. 1. p. 271.—Sorlo brasiliano, *Nap.* p. 150.—Tourmaline, *Lam.* t. 2. p. 295.—Le Schorl électrique, t. 1. p. 229.—Tourmaline-vertes et bleues, *Hauy*, t. 3. p. 31.

External Characters.

Its principal colours are green and brown: from leek green it passes into pistacio and olive green, then into liver brown, and yellowish and reddish brown, further into hyacinth red, crimson red, violet blue, azure blue, dark Berlin blue, and, lastly, into indigo blue.

Its colours are almost all of them dark, often a little muddy, and when it is nearly opaque, on account of the darkness of the colour, it appears black.

It occurs very seldom massive, oftener in rolled pieces, but most frequently crystallized.

Its fundamental crystallization is an equiangular three-sided prism, and this is either perfect or has cylindrical convex lateral planes, and is flatly acuminate on both extremities by three planes, which, on the one extremity are set on the lateral edges, but on the other, on the lateral planes. The angles, edges, and extremities of the acumination are often truncated, and the edges sometimes bevelled. When several of these alterations occur at the same time, the crystal has a very irregular aspect, and is somewhat difficult to determine. The lateral edges are frequently bevelled, and thus is formed a nine-sided prism, in which three and three planes meet under two obtuse angles. When the edges of the bevillments are truncated, a twelve-sided prism is formed; but when the bevilling planes increase so much that the original faces disappear, an equiangular six sided prism is formed.

Prisms are generally long, thin, and needle-shaped; sometimes they are also short and thick; in other varieties, although very rarely, the acuminations meet together, when a double three sided pyramid is formed, and the remainder of the prism forms truncations on the edges of the common basis*.

The lateral planes are generally strongly longitudinally streaked; the acuminating planes are mostly

* Count de Bournon describes a specimen in the collection of Sir John St Aubyn, in which the prism is completely wanting, and is, what he considers to be, the primitive figure of the tourmaline, *London Philosophical Transactions for 1802.*

smooth and shining: sometimes the planes on one extremity are smooth, but on the other rough.

The crystals are seldom large, more commonly middle sized and small, and sometimes scopiformly aggregated, as is the case with the red variety from Siberia.

They are usually imbedded.

Internally its lustre is splendid and vitreous.

Cross fracture has a tendency to foliated, and the folia appear to be a little inclined to the axis; longitudinal fracture is perfectly conchoidal, particularly in the translucent varieties.

When it verges on common schorl it presents prismatic concretions.

It alternates from nearly opaque to completely transparent.

Some varieties, when viewed in a direction oblique to the axis of the crystal, are transparent, but in the direction of the axis opaque: others again exhibit different colours according to the direction in which they are held*.

Hard, but in a higher degree than quartz.

Easily frangible.

Intermediate between not particularly heavy, and heavy.

Specific gravity—Green tourmaline 3,086, *Werner*.—3,086, *Briffon*.—From 3,0863 to 3,3626, *Hauy*.—Blue tourmaline 3,155, *Werner*.—3,130, *Briffon*.

* *Werner* has in his possession a tourmaline which is sky blue in the middle, but violet blue on the sides.

Chemical Characters.

Before the blow pipe it melts into a greyish white vesicular enamel.

Constituent Parts.

Tourmaline of Ceylon.		Of Brazil.
Silica	37,0	40,0
Alumina	39,0	39,0
Lime	15,0	3,84
Oxyd of iron	9,0	12,50
—— of manganese		2
	—————	—————
	100	97,34
	<i>Bergman,</i>	<i>Vauquelin,</i>

Physical Characters.

By friction and heating it exhibits signs of positive and negative electricity. When it is cooled the extremities change their electricity. When it is heated beyond 200° of Fahrenheit, it is deprived of its electrical properties. The more transparent varieties appear to possess the strongest electrical properties.

Geognostic Situation.

It occurs imbedded, and usually in primitive rocks, as gneiss, mica slate, clay slate, and granite.

Geographic Situation.

It was first found in the island of Ceylon, in the 16th century; afterwards in Brazil, and since that period in several other countries, as Madagascar, kingdom of Ava, Siberia, Spain, Switzerland, Tyrol, France, Saxony, Scotland, near Banff, Sweden, Norway, and Greenland.

Use.

It is sometimes cut and polished and worn as a jewel; but, on account of the muddiness of its colours, it is not in general very much esteemed.

Observations:

1. The green coloured tourmaline has been described by several mineralogists as emerald, the blue as sapphire, and the crimson red variety, which was first found in Siberia, and since in the kingdom of Ava, by Colonel Symes, and in the island of Ceylon,

by Count de Bournon, under the names daurite, fibrite, and rubellite.

2. In the collection of the Hon. Mr Greville there is a most magnificent specimen of the red variety, which was presented to Colonel Symes by the king of Ava. It is undoubtedly the finest specimen of this fossil that exists in any cabinet, and stands pre-eminent among the riches of Mr Greville's great collection*. A particular description of it is given by Count de Bournon, in his Memoir on Corundum.

In the beautiful collection belonging to Baron Racknitz at Dresden, I observed a three-sided prism of the red variety, near an inch in diameter, and an inch and half long, which cost 400 rubles.

* It is valued at 1000l.

The original of this specimen was presented to Colonel Symes by the King of Ava. It is undoubtedly the finest specimen of this fossil that exists in any cabinet, and stands pre-eminent among the riches of Mr Greville's great collection. A particular description of it is given by Count de Bournon, in his Memoir on Corundum.

TWENTIETH SPECIES.

Thumerstone. *not yetite by the true*

Thumerstein.—Werner.

Schorl transparent lenticulaire, *R. de L.* t. 2. p. 353.—
 Glafs schorl, or Glastein, *Wid.* p. 294.—Thumerstone,
Kirw. vol. 1. p. 273.—Glastein, *Klapr.* b. 2. p. 118.
 —Tumite, *Nap.* p. 158.—Janolite, *Lam.* t. 2. p. 316.
 La pierre de Thum. *Broch.* t. 1. p. 236.—Axinite,
Haüy. t. 3. p. 22.

External Characters.

Its most common colour is clove brown, of various degrees of intensity; from that it passes on the one side into plumb blue, on the other into pearl grey, ash grey, and greyish black.

It is seldom found massive, oftener disseminated, but most frequently crystallized.

1. In very flat and very oblique rhombs, in which the two opposite obtuse lateral edges are generally truncated.
2. Often the rhomb is so flat that it has a tabular aspect, and sometimes crystals of this

figure intersect one another and form a cellular shape. The truncating planes are smooth, but the others are streaked.

Externally its lustre is generally splendid; internally it alternates from glistening to shining, and is vitreous.

Fracture fine grained uneven; in the translucent varieties it sometimes approaches to splintery; in the transparent varieties, to small and imperfectly conchoidal.

Fragments indeterminately angular sharp edged.

The massive occurs in curved lamellar distinct concretions, whose surface is shining and streaked.

It alternates from perfectly transparent to weakly translucent.

Pretty hard, yielding to the file.

Very easily frangible.

Not particularly heavy, approaching to the heavy.

Specific gravity—From 3,213 to 3,300, *Hauy*.—3,295, *Kirwan*.—3,250, *Gerhard*.

Chemical Characters.

Before the blow pipe it melts easily, without addition, into a greenish white semitransparent glass.—*Lelievre*.

Constituent Parts.

Silica	52,70	44,0
Alumina	25,79	18,0
Lime	9,39	19,0
Oxyd of iron	8,63	14,0
— of manganese	1,0	4,0
	<hr/>	<hr/>
	97,51	99,0

*Klaproth, t. 2. p. 126.**Vauquelin, J. d. M.*

N. 23.

Geognostic Situation.

It appears to be peculiar to the primitive mountains, where it occurs in veins and beds of the oldest formation. It is found imbedded in limestone.

Geographic Situation.

It was first found at Thum in Saxony, whence it has its name: it has been also observed in Dauphiny, where it is accompanied with quartz crystals, asbest, actynolite, and common felspar; also near to Barrege in the Pyrenees, imbedded in calc spar, in Cornwall, at Konigsberg in Norway, and in Siberia*.

* In the museum of the University of Edinburgh there are specimens of massive thumerstone, sent by Dr Guthrie of Peterburgh, and said to be from Siberia.

T W E N T Y - F I R S T S P E C I E S .

Iron Flint.

*Eisenkiesel.—Werner.**External Characters.*

Its colour is yellowish brown, which borders on liver brown, and sometimes a colour which is intermediate between blood red and brownish red.

It occurs most commonly massive, but also crystallized in small equiangular six-sided prisms, which are acuminate on both extremities by three planes, that are unconformably-wise set on the alternate lateral planes. There are often smaller planes between the three large planes of the acuminations, and thus a six-planed acuminations is formed.

The crystals are implanted, and intersect one another.

Externally its lustre is splendid, internally shining, which sometimes verges on glistening, and is intermediate between vitreous and resinous, but more inclined to the former.

Fracture imperfectly small conchoidal, which, in some varieties approaches to uneven.

Fragments

I have an analysis made by a celebrated
German Chemist ^{Buehler} shows that the con-
stituent parts of the yellowish brown
variety of Swan flint contains
yellowish brown

- 92 Silica
5 $\frac{3}{4}$ Oxide of Iron combined
with a small portion
of manganese
1 Manganese
1 Volatile matter
-

Reddish Brown

- 95 Silica
5 Oxide of Iron
-

- 76 $\frac{5}{6}$ Silica
2 $\frac{3}{6}$ Oxide of Iron
1 Volatile Matter
 $\frac{1}{4}$ Alumina

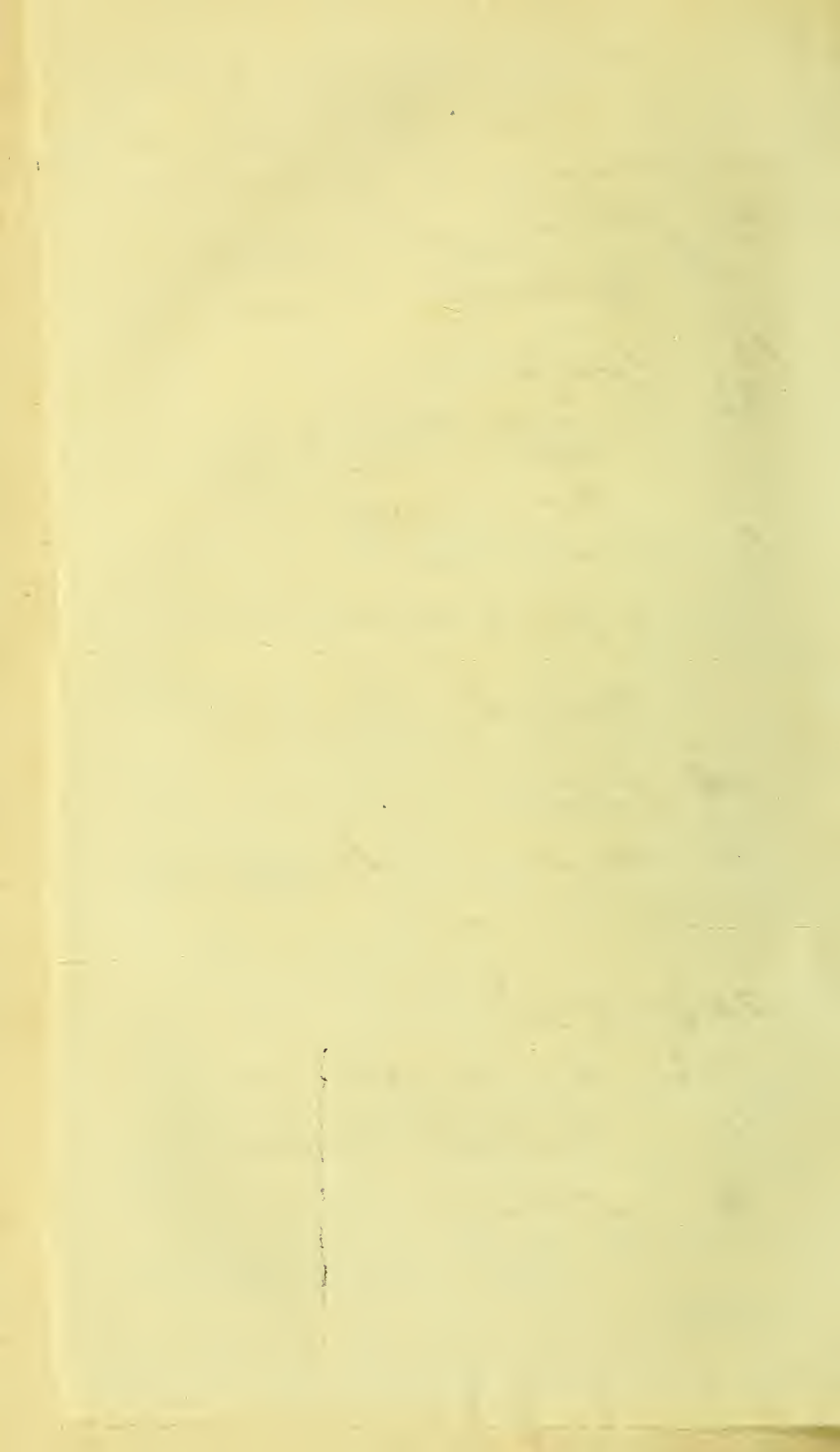

Fragments indeterminately angular, not particularly sharp edged.

It occurs almost always in small grained distinct concretions, which approach sometimes to the fine, and more rarely to the coarse grained.

It is opaque and slightly translucent on the edges.

Pretty hard, yielding to the file.

Somewhat difficultly frangible.

Not particularly heavy, approaching to heavy.

Geognostic Situation.

It occurs in iron-stone veins, and appears to be an intimate mixture of quartz and iron ochre,

Geographic Situation.

It is found at Eibenstock and Altenberg in Saxony, and, Karsten says, also at Bristol in England.

Observation.

It renders the iron ore, along with which it occurs, very difficult of fusion.

TWENTY-SECOND SPECIES.

Quartz.

Quarz.—*Werner*.

Werner divides this species into five subspecies,
 1. Amethyst, 2. Rock Crystal, 3. Milk Quartz,
 4. Common Quartz, 5. Prase.

FIRST SUBSPECIES.

This subspecies is divided by Werner into two
 kinds, *a*. Common Amethyst, *b*. Thick fibrous
 Amethyst.

FIRST KIND.

Common Amethyst.

Gemeiner Amethyst.—*Werner*.

External Characters.

Its principal colour is violet blue of all degrees of intensity. It passes on the one side from dark violet blue, through plumb blue into clove brown, and a particular kind of brownish black; on the other side from pale violet blue through pearl grey, ash grey, greyish white, greenish white, olive green, into pistacio green, which latter is uncommonly rare.

In the massive varieties, several colours occur together, and these are disposed in stripes, or fortification-wise.

Besides massive it occurs in rolled pieces, in angular pieces, and very frequently crystallized.

In equiangular rather obtuse six-sided pyramids, which are generally double, and, when that is the case, are either perfect or truncated on the common basis, and the lateral planes of the one are set on those of the other.

The crystals always occur in druses, and are commonly heaped on one another, or penetrate one another. They are middle sized and small.

The planes of the crystals are smooth.

Externally its lustre is splendid, internally it passes from splendid, through shining, to glistening, and is vitreous.

Fracture passes from perfectly conchoidal into imperfectly conchoidal; also into uneven, and even into coarse splintery. The first has the greatest lustre and greatest transparency.

Fragments indeterminately angular and sharp edged.

The massive is commonly composed of more or less perfectly straight and thick prismatic distinct concretions, which are obliquely transversely streaked, and, when free at the extremities shoot into crystals. These distinct concretions are generally intersected by other fortification-wise bent lamellar distinct concretions, and the colour delineation arranges itself in the direction of these lamellar concretions.

Sometimes the prismatic concretions, when they are very short, (which is very seldom the case) approach to coarse grained distinct concretions.

It alternates from completely transparent to translucent.

Hard, yields to the file.

Brittle.

Pretty easily frangible.

Not particularly heavy.

Specific gravity—2,750.

Chemical Characters.

Lampadius exposed it for four hours to the strongest heat of a wind furnace, when it suffered no other change but the loss of its colour, and about one and a quarter per cent. of its weight *. According to Ehermann, when exposed to a stream of oxygen gas, it loses its colour and melts to a transparent ball.

Constituent Parts.

Silica	97,50
Alumina	0,25
Oxyd of iron	0,50
Trace of manganese	

98,25

Rose, *Karsten's Tabell.* f. 23.

Geognostic Situation.

It occurs sometimes in veins in primitive rocks, and sometimes in agate balls and kidneys in porphyry and amygdaloid. The veins in which it occurs are either proper veins, and then it occurs along with the fibrous kind on which it rests, or they are agate veins, of which it commonly makes the middle. When it

* Lampad. Saml. Pract. Chem. Abhandl. b. 1. f. 225.

occurs in balls and kidneys, it cruffs their surface with beautiful crystals.

Geographic Situation.

It is found abundantly in Saxony, as at Annaberg, Cunnersdorf near Dresden, the Coralbrüche near Freyberg, at Schneeberg, Volkenstein, &c. also in the Harz, in the Uralian mountains, and in the East Indies. The green variety is found in the county of Glatz in Silesia; also in the Palatinate, where it occurs in amygdaloid. The most beautiful varieties are found at Catharinaburg in Russia.

Use.

It is cut into rings, seals, and boxes, but it is not highly valued.

Observations.

1. The green variety is the chrysolite of some authors.
2. The oriental amethyst is sapphire.
3. It is sometimes covered with capillary crystals of iron mica, and, when viewed in certain positions, appears red; this variety is named hair amethyst.

SECOND KIND.

Thick fibrous Amethyst.

Dickfafriger Amethyst.—*Werner*.

External Characters.

It has generally a pretty dark violet blue colour, which when pale and light borders on pearl grey, and from this latter passes into milk and yellowish white.

It occurs only massive and in rolled pieces.

Internally its lustre is glistening, passing into shining, and is vitreous.

It has a double fracture; the principal fracture is thick fibrous, and is straight, and scopiformly diverging fibrous, and it sometimes passes into splintery, so that we may often consider it as intermediate between thin fibrous and splintery; the cross fracture is imperfectly conchoidal, and sometimes intermediate between uneven and splintery.

Fragments indeterminately angular, sometimes wedge-shaped, sometimes sharp edged.

It shews a disposition to coarse and angular grained distinct concretions, and they are so very intimately

mately grown together, that it is difficult to discover the faces of the concretions.

Commonly translucent, but in some varieties approaching to transparent.

Hard.

Not particularly difficultly frangible.

It agrees in the remaining characters with the preceding kind.

Geognostic Situation.

It is found in agate veins, and is generally accompanied with common amethyst. When both kinds occur together in the same vein; the fibrous is always the oldest, or adheres to the wall of the rent.

Geographic Situation.

Nearly the same as the former.

SECOND SUBSPECIES.

Rock or mountain Crystal.

Bergcrystal.—*Werner*.

Quarzum pellucidum cristallizatum, *Wall.* p. 226.—Cristal de roche, *R. d L.* t. 2. p. 70.—Berg crystal, *Wern. Cronst.* p. 111. *Id. Wid.* p. 296.—Mountain crystal, *Kirw.* p. 241.—Bergcrystal, *Emm.* b. 1. p. 217. *Ibid Estner*, b. 2. f. 318.—Quarzo, *Nap.* p. 170.—Quartz, *Lam.* t. 2. p. 119.—Le Cristal de Roche, *Broch.* t. 2. p. 243.—Quartz, *Haiiy*, t. 2. p. 406.

External Characters.

Its principal colour is white, it occurs often also brown. From snow white it passes into greyish white, yellowish white, and reddish white; from greyish white it passes into pearl grey; from yellowish white it passes through pale ochre yellow, wine yellow, yellowish brown, clove brown, which falls into red, into brownish black; from yellowish brown it passes into orange yellow and hyacinth red.

Of these colours, white and brown are the most common; the clove brown is known by the name
of

of smoky topaz. It is characteristic of this fossil, that the yellow and brown colours are not unoften disposed in striped delineations.

If it occurs massive it is very rarely: often in rolled pieces, and very often in crystals. Its crystallizations are the following.

1. Equiangular six-sided prism, somewhat acutely acuminate on both ends, by six planes, which are set on the lateral planes.
2. When the prism becomes shorter, a double six-sided pyramid is formed, in which the lateral planes of the one are set on the lateral planes of the other, and the remains of the prism form a truncation on the common basis; or the truncation is entirely wanting.
3. The prism is sometimes so broad that it resembles an equiangular four-sided table of which the angles and edges are bevelled: Sometimes the lateral planes incline toward the ends; in some varieties one acuminating plane is very large in comparison to the other: in others three planes in each pyramid become so large, that the others disappear, when a double three-sided pyramid is formed.
4. Sometimes in the double six-sided pyramid three alternate planes in each pyramid become larger than the others, and thus a figure approaching to the cube is formed.

Sometimes

Sometimes we meet with twin crystals, where one crystal penetrates the other longitudinally, and the upper is larger than the under.

Crystals are from uncommonly large to small, but are most commonly middle sized and large. The prisms are always larger than the pyramids, are heaped on one another, and sometimes the prisms are hollow, and contain drops of water. The pyramids are all around crystallized and imbedded.

Crystals of actynolite, rutile and fibres of amianth are sometimes dispersed through it.

The lateral planes of the crystals are transversely streaked, but the acuminating planes are smooth.

Externally, the crystals are generally splendent, the rolled pieces are only glistening, passing into glimmering; internally they are splendent and vitreous.

Fracture almost always perfectly conchoidal, seldom flat conchoidal, sometimes so flat that it verges on the concealed foliated, and in some rare varieties it shews a complete concealed foliated fracture, and the folia are parallel with the planes of the six-sided pyramid, or with the acuminating planes of the six-sided prism.

Fragments indeterminately angular, very sharp-edged.

It extremely rarely occurs in granular and prismatic distinct concretions.

It is always transparent*, and in certain directions duplicating.

Pretty hard, yielding to the file.

Pretty easily frangible.

Not particularly heavy:

Specific gravity—2,650, rock crystal from Madagascar, *Brisson*.—2,605, clove brown crystal, *Karsten*.—2,888, snow white transparent, from Marmarosch, *Ibid*.

Chemical Characters.

Completely infusible by the blow pipe, and, according to Lavoisier, it remains unaltered even when exposed to a stream of oxygen gas. Coloured rock crystal, if carefully exposed to a gentle heat, loses its colour, but retains its transparency.

Constituent Parts.

Silica	93,0
Alumina	6,0
Lime	1,0
	—
	100

Bergman, Opusc. vol. 2, p. 112.

* In transparent crystals we generally find their basis and point of adherence nearly opaque.

Frangibility is a consequence of the structure of the crystal.

A species of Rock crystal has been
analysed by Bucholz
that contained $99\frac{3}{4}\%$ Silica

Physical Character.

When two rock crystals are rubbed together, they are phosphorescent in the dark, and exhale a peculiar empyreumatic odour. Its inflammability has not been proved, although, - from its oryctognostic affinity to diamond, it is not improbable that it is an inflammable body. *See complete list of minerals in the appendix of Mr. Sawey*

Geognostic Situation.

It occurs in veins and druses, and is almost exclusively confined to primitive rocks, particularly granite and mica slate; it is also found, although rarely, in clay porphyry, and gypsum.

Geographic Situation.

It is found in abundance in the lofty Alps of Switzerland and Savoy, also in Hungary, Saxony, Cornwall in England, Scotland, island of Arran, where it lines granite druses, also the mountain of Cairngorum in Aberdeenshire, and Shetland islands*.

* Mineralogy of the Scottish isles, vol. 2.

Use.

It is used as an article of jewellery and several of the varieties, particularly the wine and orange yellow, are much prized. Those from the mountain Cairngorum have been long admired on account of their purity and beautiful colour.

THIRD SUBSPECIES.

Milk Quartz.

Milch Quarz.—*Werner*.

Rosen rother quarz. *Wid.* p. 301.—Rose red quartz, *Kirw.* vol. 1, p. 245.—Milch quartz, *Emm.* b. 1. f. 136.—Quartz laiteux, *Lam.* t. 2, p. 123.—Quartz laiteux ou Quartz Rose, *Brach.* t. 1, p. 246.—Quartz-hyalin-laiteux, *Haüy*.

External Characters.

It has sometimes a milk white, but more commonly a rose red colour, which is of all degrees of intensity, and sometimes approaches to the flesh red. The rose red sometimes passes into crimson red, and from this into reddish white, and a kind of pearl grey, and lastly into milk white, which exhibits a yellowish light.

It occurs only massive*.

* *Werner* has never seen it crystallized.

Internally

Internally its lustre is shining, and sometimes passes to splendid, and is vitreous, inclining a little to resinous.

Fracture more or less perfectly conchoidal.

Fragments indeterminately angular sharp edged.

Some varieties shew a tendency to straight and thick lamellar distinct concretions.

It is more or less semitransparent, even approaching to translucent. The semitransparent varieties have the greatest degree of lustre, and a conchoidal fracture; the less transparent have less lustre, and a splintery fracture.

— Pretty hard, yielding to the file.

— Easily frangible.

— Not particularly heavy.

Other characters the same as those of rock crystal.

Constituent Parts.

Werner suspects that it is composed of silica and oxyd of manganese.

Geognostic Situation.

It is found constituting beds, but never veins, in primitive mountains, and is said by Flurl to form part of a Bavarian granite.

Geographic Situation.

It was first discovered in Bavaria, afterwards in Sweden, Greenland, at Hohenstein in Saxony, Siberia, and in the island of Coll, one of the Scottish Hebrides.

Use.

1. It is employed in jewellery. It takes a good polish, and when the colour is good the ornaments made of it are beautiful. When cut and polished and of a good colour, it is sold for spinelle, yet its deficiency in hardness, transparency, and fire is so great, that the deception is easily detected.

2. The milk white variety, when cut, opalesces into wine yellow.

3. It loses its colour by keeping, particularly if in a warm place.

FOURTH SUBSPECIES.

Common Quartz.

Gemeiner Quartz.—*Werner*.

Quartzum rude, *Wall.* t. 1, p. 220. — *R. d. L.* Gemeiner quarz. *Wid.* p. 300.—Quartz. *Kirw.* vol. 1. p. 242.—*Estner*, b. 2. f. 263.—*Id.* *Emm.* b. 1. f. 125.—Quarzo. *Nap.* p. 170. *Lam.* t. 2. p. 119.—Quartz-Hyalin amorphe, *Hauy*,—Le Quartz commune, *Broch.* t. 1, p. 248.

External Characters.

Its most common colours are white and grey. Of white the following varieties have been observed: snow white, greyish white, yellowish white, greenish white, and reddish white: from the greenish white it passes into a middle colour between verdigris green, seladon green, and apple green.

It occurs also brown, yellow, green, and red.

The varieties of grey are ash grey, smoke grey, yellowish grey, blueish grey, and pearl grey. From the yellowish grey it passes into wax and honey yellow; from the pearl grey into flesh red, which sometimes approaches to blood and brick red, and further

into

into hyacinth red, reddish brown, and pale chesnut brown.

Of these colours, white and grey are the most frequent ; next in frequency is red, the others are rare. Smoke grey is in some varieties so dark that it passes into greyish black.

It is found massive, disseminated, in blunt edged pieces, in roundish grains, and rolled pieces. Further it occurs in a great variety of external shapes, as reniform, specular, cellular, and with impressions ; of the cellular it presents the following varieties, hexagonal, polygonal, and parallelly, double, and spongi-form circularly cellular.

The polygonal cellular is either large or small cellular. Of the cellular the polygonal, and parallelly circularly cellular are the rarest.

With impressions it occurs in tables, cubes and pyramids.

It occurs also corroded, amorphous, and sometimes stalactitical.

It occurs in true and supposititious crystals.

The true crystals are nearly the same with those of the amethyst and rock crystal ; they unite both, only they are here less regular and more aggregated.

1. Six-sided prism acuminated on both ends by six planes. It is either fully crystallized on both extremities, and then it is imbedded, or only crystallized at one extremity, and then it adheres.

2. Simple six-sided pyramid. The crystals of this figure are either simple, heaped on one another, or bud-shaped aggregated.

3. Double six-sided pyramid, which is sometimes aggregated in rows.

The prism occurs of every size, from small to very large; on the contrary, the pyramid occurs only from middle-sized to very small.

Surface of the crystals is the same as in rock crystal.

Of the supposititious crystals, the following are known.

1. Complete cube; originates from fluor spar (found at Schneeberg.)
2. Equiangular and equilateral octaedron; originates from fluor spar.
3. Oblique six-sided table; originates from baryte.
4. Acute six-sided pyramid; originates from calc spar.

These crystals have a rough surface.

Externally the lustre of the true crystals varies from splendid to glistening, the rolled pieces are glimmering, passing into dull.

Internally it is shining, which on the one side borders on splendid, on the other passes through glistening, and nearly approaches glimmering, and is vitreous.

Fracture coarse and fine splintery, and imperfectly conchoidal. Some rare varieties shew a parallelly fibrous fracture, resembling that of gypsum, and others a concealed foliated fracture.

Fragments indeterminately angular, and pretty sharp edged.

Massive.

Occurs

Occurs most commonly unseparated, but often also in prismatic distinct concretions, which are straight, thin, thick, and very thick, sometimes wedge shaped, transversely streaked, and, in most cases, more imperfect than amethyst. It occurs but seldom in granular distinct concretions, and when it does, the concretions are almost always fine, seldom small grained, and commonly intimately attached to each other: it very rarely occurs in large grained distinct concretions, and this only in the remarkable quartz from Oibena. The fine grained variety has a slaty texture, and in thin tables is flexible.

It is most commonly translucent, seldom semitransparent, and this latter only in the crystallized varieties; in the darker varieties it is only translucent on the edges.

Pretty hard,

Brittle.

Not particularly difficultly frangible, more difficultly frangible than rock crystal.

Not particularly heavy.

Specific gravity—26,404, 26,546.

Chemical Characters.

It is infusible without addition before the blow pipe, but when exposed to a stream of oxygen gas, according to Ehrmann, it melts into a milk white porcellaneous ball.

Geognostic Situation.

It occurs very abundantly in the mineral kingdom. It is found forming whole rocks, also in beds and veins, and is a constituent part of granite, gneufs, mica slate, and sandstone, and also occurs in clay slate.

Geographic Situation.

It is very univerfally distributed.

Ufe.

It is employed in place of fand in the manufactory of glafs, also in the preparation of fmalt, and as an ingredient in porcelain and different kinds of earthen ware. The variety known by the name Avanturine is cut for ring ftones, and is fometimes much prized.

Observations.

1. The variety called avanturine has a reddish brown colour, and is marked with points and spots that glimmer like gold. It is found in Bohemia and Arragon.

Mafese Quartz

97 Silica

42 Ferruginous Alumina

1 Water Buckshotz

2. A variety of felspar has also been denominated avanturine.

3. The blood red variety of quartz, which is found in Spain, was formerly considered to be hyacinth.

4. Some varieties of quartz, when burnt, acquire a reddish colour, and are then not unlike avanturine.

as used in the stone called blood stone or hyacinth used by the ancients for the purpose of divination

FIFTH SUBSPECIES.

Prase.

Prasem.—*Werner*.

Prasem. *Wern. Cronst.* f. 116.—Lauchgrüner quartz, *Wid.* p. 301.—Prasium, *Kirw.* vol. 1. p. 249—*Id. Estner*, b. 2. f. 207. *Id. Emm.* b. 1. f. 103.—Quarzo verde di porro, *Nap.* p. 171.—La Prase, *Broch.* t. 2. p. 252—Quarz-hyalin verd obscur, *Hauy*.

External Characters.

Its colour is leek green, of various degrees of intensity.

Occurs generally massive, seldom crystallized.

Its

Its crystallizations are, 1. six-sided prism, acuminated by six planes, like quartz. 2. Six-sided pyramid, but this is rare.

Crystals small, and middle-sized, and have always a drusy surface.

Lustre shining, approaching to glistening, and between resinous and vitreous.

Fracture coarse splintery, which sometimes approaches to the imperfectly small conchoidal.

Fragments indeterminately angular, more or less sharp edged.

The massive varieties occur in cuneiformly thick, diverging, prismatic, distinct concretions, and sometimes in coarse grained distinct concretions.

Surface of the concretions rough and transversely streaked.

Translucent.

Hard.

Difficultly frangible.

Not particularly heavy. *Some specimens have been seen with pyrites.*

Geognostic Situation.

At Breitenbrun it occurs in a mineral bed, which is composed of magnetic pyrites, iron pyrites, copper pyrites, lead glance, blende, quartz, calc spar, and common actynolite.

Phvase

98 Silica

1 Oxide of Iron

1/2 Alumina combined with
Manganese

Geographic Situation.

It is found at Breitenbrün near Schwartzenberg, in the electorate of Saxony, and it is said also to have been found in Finland and Siberia.

Use.

It is sometimes cut and polished for ornamental purposes.

Observation.

It is an intimate mixture of quartz and actynolite.

General Observations on the species Quartz.

It is one of the purest species of the flint genus; is the most abundant of fossils; and occurs in almost every geognostic situation.

In the primitive mountains it forms an essential constituent part of several of the most mighty rock formations, as granite, gneufs, and mica slate: it occurs also imbedded in porphyry, in great rocky masses, in beds, veins, and nests; and either alone or accompanied with other fossils.

In the transition rocks it forms a constituent part of grey wacce and of many veins.

In the floetz rocks it forms the principal constituent part of the different great sandstone formations, and occurs also in the gyps and limestone formations.

Even in the newest of all the formations, the alluvial, it is found in boulders and as loose sand.

Several varieties, as we have already mentioned, are by no means so common; thus the quartz, with date-shaped distinct concretions, is only found in Silesia: the larger cellular variety only at Schneeberg in Saxony; the small cellular only in the Harz and Hungary; and lastly, the fine angular grained, flaty and flexible variety has been hitherto found only in the Brazils.

The picture of the quartz species which has been described in the preceding pages is one of the most highly finished in the Wernerian oryctognosie. Wiedenman and other mineralogists by attending only to a few of its least characteriffic features, have failed in understanding it.

TWENTY-THIRD SPECIES.

Hornstone.

Hornstein.—*Werner*.

Werner divides this species into three subspecies.

1. Splintery hornstone.
2. Conchoidal hornstone.
3. Woodstone.

FIRST SUBSPECIES.

Le Hornstein ecailleux, *Broch.* t. 1. p. 255.

External Characters.

Its most common colour is grey, frequently also red, but seldom of other colours. Of grey it presents the following varieties; blueish, greenish, yellowish, smoke and pearl grey; from pearl grey it passes into flesh red, sometimes even into blood red and brownish red, and from greenish grey it passes into mountain and olive green.

Y

It

It is found most commonly massive, seldom in rolled pieces, and in large balls, and very seldom with pyramidal impressions of calc-spar.

Fracture splintery, generally fine splintery, and often with a slight inclination to conchoidal.

Internally its lustre is dull ; it is glimmering when it approaches to the nature of quartz.

Fragments indeterminately angular, more or less sharp edged.

It is almost always unseparated ; the globular occurs in concentric lamellar distinct concretions.

It is more or less translucent on the edges, and sometimes it is in a slight degree translucent.

Hard.

Brittle.

Very difficultly frangible.

Not particularly heavy.

Chemical Characters.

Infusible without addition before the blow pipe. Some mineralogists assert that it is easily fusible without addition ; but their experiments appear to have been made with compact felspar, which to an unexperienced eye might be mistaken for hornstone.

Geognostic Situation.

Found in veins, in the shape of balls, in limestone; and sometimes forming the basis of porphyry.

Geographic Situation.

It is found at Schneeberg, Freyberg, Johangeorgenstadt, in veins; and globular in limestone in Bavaria. It is also found in Sweden, at Dannemora and Garpenberg, where it forms the basis of porphyry; also in the Shetland islands, where it forms the basis of porphyry*.

Observations.

It appears to differ from quartz in containing a greater proportion of alumina; when it contains a large quantity it passes into jasper.

It sometimes borders on chalcedony and flint.

* Mineralogy of the Scottish isles, vol. 2.

SECOND SUBSPECIES.

Conchoidal Hornstone.

Muschlicher Hornstein.—*Werner*.Le Hornstein conchoide, *Broch.* t. 1. p. 250.*External Characters.*

It is commonly greyish white, yellowish white, greenish and pearl grey; from this it passes into flesh red and cherry red, and from greenish grey it passes into mountain green.

It sometimes exhibits spotted, striped, and clouded delineations.

It occurs only massive.

Internally it is scarcely glistening, approaching to glimmering.

Fracture—nearly perfectly conchoidal.

Fragments indeterminately angular, pretty sharp-edged.

It never occurs in distinct concretions.

Strongly translucent on the edges.

Hard.

Easily

Easily frangible.

Not particularly heavy.

Geognostic Situation.

It occurs in beds; also in veins, accompanied with agate.

Geographic Situation.

It is found at the Friedlichen Vertrage at Goldberg in Saxony. *Also in the Sandstone hills*

Observations.

1. It is distinguished from the preceding species by the lightness of its colours, its conchoidal fracture, and its inferior translucency and hardness.
2. It seems to be allied to ribbon jasper.

THIRD SUBSPECIES.

Woodstone.

Holzstein.—*Werner*.

Holzstein, *Wid.* p. 329.—Woodstone, *Kirw.* v. I. p. 315.
 —Le bois pétrifié ou le Holzstein, *Broch* t. I, p. 259.

External Characters.

Its most common colour is ash grey, from this it passes into greyish black, which falls a little into yellow and brown, further into yellowish grey and pearl grey, and from this into flesh red, blood red, and brownish red. From the yellowish grey it passes into ochre yellow. It occurs also greyish white.

In general several colours occur together, and it commonly exhibits colour delineations, as clouded and striped, and these arrange themselves in the direction of the original woody texture.

Its shape is exactly conformable to its former woody shape, so that it sometimes occurs in the form of trunk, branches, and roots. It shews often its former woody texture.

Sometimes

Sometimes found in rolled pieces.

External surface uneven and rough.

Internally it is sometimes dull, sometimes glimmering and glistening, according as it is more or less of the nature of the two preceding subspecies.

Cross fracture imperfectly conchoidal; longitudinal fracture splintery and fibrous.

Fragments indeterminately angular, not sharp-edged.

Slightly translucent, or translucent on the edges,

Pretty hard, but not so hard as splintery hornstone.

Easily frangible.

Not particularly heavy; lighter than splintery hornstone.

Geognostic Situation.

It is found insulated in sandy loam.

Geographic Situation.

It is found in Saxony, Bohemia, Russia, Hungary, and at Loch Neagh in Ireland, *Siberia & others*
in country

Use.

It receives a good polish, and serves for the same purposes as agate.

Observation:

Observation.

At first sight it may appear inconsistent to consider a petrefaction as a particular fossil species ; when we reflect, however, that woodstone differs in its external characters from all other fossils, the justness of the Wernerian method will become evident. Many other fossils occur in the shape of petrefactions, but they are almost always identical with some known species, and therefore are to be considered only as varieties of the external shape of the particular fossil to which they belong.

TWENTY-FOURTH SPECIES.

Flint.

Feurstein.—*Werner.*

Silex ignarius, *Wall*, t. o. p. 275.—Feurstein, *Wid.* p. 308

Flint, *Kirw.* vol. 1. p. 301.—Feurstein, *Efner.* b. 2.

f. 360. *Id. Emm.* b. 1. f. 143,—Pietra focacia, *Nap.*

p. 180.—*Silex* ou Pierre a fusil, *Lam.* t. 1. p. 137. *Id.*

Broch. t. 1, p. 263.—Quartz, agathe, pyromaque, *Haüy.*

External Characters.

Its most common colour is grey, of which the following varieties occur: ash grey, yellowish grey, and smoke grey. From smoke grey it passes on the one side through ash grey, into greyish black; on the other into yellowish grey, and a colour intermediate between ochre and wax yellow; further, into yellowish brown, reddish brown, and into a middle colour between blood red and brownish red.

It sometimes presents colour delineations, as zoned, striped and flamed.

Besides massive, in regular plates, in angular grains and pieces; it occurs also in globular and elliptical

rolled pieces, in the form of sand, and tuberoſe and perforated.

It ſometimes, although rarely, occurs in ſuppoſitious cryſtals. Theſe are,

1. Flat double three-sided pyramid.
2. Six-sided priſm; acuminated by three planes.

Theſe cryſtals are internally hollow, and are derived from calc-ſpar.

Occurs in extraneous external ſhapes, viz. in the form of echinites, corallites, &c.

The external ſurface of the angular pieces is ſmooth and glistening, that of the other ſhapes is ſometimes rough, ſometimes uneven.

Internal luſtre glimmering.

Fracture perfectly conchoidal.

Fragments indeterminately angular, and ſometimes tabular, and very ſharp edged.

Generally unſeparated, ſometimes occurring in lamellar diſtinct concretions.

Tranſlucent, the blackiſh varieties ſeldom more than tranſlucent on the edges.

Hard, a little more than quartz.

Eaſily frangible.

Not particularly heavy.

Specific gravity—2,594, *Blumenbach*—2,581, *Celler*.

Chemical Character.

Before the blow pipe it is infusible without addition.

Constituent Parts.

Silica	98,0	97,0
Lime	0,50	
Alumina	0,25	1,0
Oxyd of Iron	0,25	
Loss	1,00	2,0
	<hr/>	<hr/>
	100	100
	<i>Klaproth.</i>	<i>Vauquelin.</i>

Geognostic Situation.

It is almost exclusively confined to the Floetz mountains; there it occurs in beds, or imbedded in limestone and chalk. In the alluvial land it is found only in rolled pieces, and in the primitive mountains in small quantity in veins.

Geographic Situation.

It is found in the Danish islands of Rugen and Zealand; in Spain; in France, where it occurs of a beautiful

beautiful brown colour; at Muskaw in Lusatia; in agate balls in the Pfalz; in England in great abundance; the north of Ireland, and very rarely in Scotland. Brochant informs us that in the south of France hollow globular flint is found, which contains sulphur in its interior, vol. 1, p. 267.

Uses.

Great quantities of it are manufactured into gun flints, and it is often employed in the place of quartz in the manufactory of glass, porcelain and smalt.

Observations.

1. The mode of formation of imbedded flint, has been a subject of considerable controversy, and many different explanations have been proposed. The most probable, and the only explanation we shall at present mention, is that which was first proposed by Werner, viz. ‘that during the deposition of chalk, air was evolved, which, in endeavouring to escape, formed irregular cavities, that were afterwards filled up, by infiltrations, with flint’.

2. It is often covered with a whitish crust, which is most usually produced by weathering; in other instances appears to be an original formation.

TWENTY-FIFTH SPECIES.

Chalcedony.

Chalcedon.—*Werner.*

Werner divides this species into two subspecies:

1. Chalcedony, and
2. Carnelian.

FIRST SUBSPECIES.

Common Chalcedony.

Gemeiner Calzedon.—*Werner*.

Achates chalcedonius, *Wall.* t. 1. p. 298. — *Calcedoine*, *R. d. L.* t. 2. p. 145.—*Gemeiner chalzedon*, *Wid.* p. 317. *Common chalcedony*, *Kirw.* vol. 1. p. 298.—*Chalcedon*, *Esfner*, b. 2. f. 368. *Id. Emm.* b. 1. f. 151.—*Calcedonia*, *Nap.* p. 183.—*La Calcedoine*, *Lam.* t. 2. p. 142. *Id. Broch.* t. 1. p. 268.—*Quartz, agathe, calcedoine*, *Hauy*.

External Characters.

Its most common colour is grey, of which the following varieties occur: smoke grey, blueish grey, pearl grey, greenish grey, and yellowish grey. The blueish grey passes into milk white and smalt blue; the greenish grey into a colour which is intermediate between grass and apple green; the yellowish grey passes into honey yellow, wax yellow, and ochre yellow; from this into yellowish brown, blackish brown, and brownish black.

The two last mentioned colours are very dark, and when held between the eye and the light appear blood red.

The green and blue varieties are the rarest.

White and brown stripes often alternate with each other, and form the variety named onyx.

The milk white variety is known by the name cachalong.

The grey varieties with thick prismatic distinct concretions, when transversely cut, and held between the eye and the light, exhibit rainbow colours, and hence have been named rainbow chalcedony.

When it is cut parallel to the distinct concretions, it exhibits a clouded delineation.

External shape very various; besides massive, in blunt edged pieces, grains and rolled pieces, it occurs in original round balls (which are found in Amygdaloid, and often filled with water) reniform, botroidal, coralloidal, stalactitical; also crystallized in cubes?

Also found in extraneous external shapes, as in turbinites, tubulites, &c.

Internally almost always dull; some rare varieties exhibit a very faint degree of lustre.

Fracture perfectly even; it passes sometimes, however, into fine splintery, also into the uneven, which approaches to the imperfectly flat conchoidal. The latter variety has a slight degree of lustre.

Fragments indeterminately angular, and pretty sharp edged.

Generally occurs in reniform and fortification-wise curved lamellar, usually concentric, distinct concretions, which are commonly very thin, and have a rough and dull surface.

Commonly

Commonly semitransparent; but the black and white varieties only translucent.

Hard, and rather more so than flint,

Brittle.

Somewhat difficultly frangible.

Not particularly heavy.

Specific gravity — 2,600 to 2,655, *Kirwan*. — 2,586, *Briffon*. — 2,615, *Blumenbach*.

Chemical Character.

Infusible before the blowpipe without addition.

Constituent Parts.

Silica	84
--------	----

Alumina	16
---------	----

Bergman. *Opuscul.* 2. p. 60.

Geognostic Situation.

Occurs most commonly in balls, in amygdaloid, also in angular pieces and veins, in porphyry and amygdaloid. When it occurs in veins it is often stactitical, reniform, and coralloidal*.

* The coralloidal variety is found in veins in Cornwall.

Geographic Situation.

The cubic variety occurs in Transilvania, and the other varieties in Iceland, Feroe islands, Silesia, Saxony, Siberia, Cornwall, Scotland, islands of Egg, Rume*, &c.

Uses.

As it is susceptible of a fine polish it is employed as an article of jewellery.

Observations.

1. The name of this species is derived from the province of Chalcedon, in Asia, where it was first found.

2, Onyx, on account of the high polish which it is capable of receiving, is very much prized, and is considered as the most valuable variety of this species. It is principally cut in bas relief work, and the finest specimens for that purpose are brought from the East Indies.

3. The dendritic variety is named Mocha stone, because it was supposed to have been originally brought from Mocha in Arabia. Veltheim, however, informs

* Mineralogy of the Scottish isles, vol. 2.

us that no stone of this kind is found near Mocha, and affirms that mocha is a corruption of the German word mochs, which signifies moss. It is the next in value to the onyx.

4. The cubic appears rather to be a variety of milk quartz, than of chalcedony, as it agrees with it in fracture, lustre and colour.

Handwritten note: This is a variety of milk quartz, than of chalcedony, as it agrees with it in fracture, lustre and colour.

Handwritten note: It differs from the most common by its

SECOND SUBSPECIES.

Carnelian.

Karniol.—Werner.

Achates carneolus, *Wall.* t. 1. p. 185.—Cornaline, *R. de L.* t. 2. p. 146.—Blutrothe kalzedon, *Wid.* p. 318.—Carnelian, *Kirw.* vol. 1. p. 300—Karniol, *Emm.* b. 1. f. 157.—Carniola, *Nap.* p. 185.—Agathe cornaline, *Lam.* t. 2. p. 147.—La Cornaline, *Broch.* vol. 1. p. 272.—Quartz-agathe.cornaline, *Haiiy.*

External Characters.

Its principal colour is blood red, of all degrees of intensity, (the deepest shade falls into brown, and

some approach to yellow and others to white), from this it passes into flesh red, reddish white, milk white, and into a kind of yellow. Some varieties approach to the reddish brown.

It sometimes presents zoned and dendritic colour delineations.

The white variety sometimes alternates with stripes of a reddish colour.

It has usually a reddish brown coloured crust.

It commonly occurs in roundish pieces, and also in layers in agate.

External surface rough and uneven.

Fracture perfectly conchoidal.

Lustre glistening, bordering on glimmering.

Fragments indeterminately angular and very sharp-edged.

Most commonly unseparated, yet in some varieties it shews a tendency to concentric and fortification-wise bent lamellar distinct concretions, and according to the disposition of these the colour delineations are formed.

Semitransparent, and agrees with common chalcedony in other characters.

Geognostic Situation.

It is found accompanying agate, and, in general, has the same geognostic situation as Chalcedony.

The fine oriental varieties occur in rolled pieces.

Geographic

Geographic Situation.

The most beautiful carnelian is brought us from Arabia, and Surat and Cambay in Hindostan. It is also found in different parts of Europe.

Use.

It is used for seals, bracelets, crosses, and other ornaments.

Observations.

1. The oriental carnelian is far handsomer than that which is found in Europe; the blood red colour of the European is impure and muddy, so that it does not receive so good a lustre and polish as the Indian.

2. The white variety, which alternates with stripes of red, and also the arborescent are by Cronsted named Sardonyx; although they are very different from the sardonyx of the antiquary. Werner in this follows Cronsted:

3. The name is derived from its colour, as it was considered to resemble flesh.

4. Werner supposes that the red colour is not original, but has been produced by the infiltration of an iron matter.

This is also found in the ... Agate.

Agate.

The fossils known by the name Agate are all compound, therefore are more properly objects of geognosie than oryctognosie. Werner, however, has placed them in his oryctognostic system as an appendix to the species chalcedony, probably on account of their occurring in inconsiderable quantity, and from chalcedony forming their principal constituent part.

They are compounded of chalcedony, carnelian, jasper, hornstone, quartz, heliotrope, amethyst, indurated lithomarga, and opal. These different fossils do not occur in every agate, most commonly only two or three, a circumstance which affords us a basis for an arrangement of them according to their constituent parts. Such an arrangement, however, would be very difficultly accomplished; hence Werner has preferred the easier method of disposing them according to their colour delineations. These delineations are formed by the manner of junction of the different fossils.

The following are the different kinds of agate mentioned by Werner: 1. Fortification agate. 2. Landscape agate. 3. Ribbon agate. 4. Moss agate. 5. Tube agate. 6. Clouded agate. 7. Zoned agate. 8. Star agate. 9. Fragment agate. 10. Punctat-

tated agate. 11. Petrefaction agate. 12. Coral agate, and 13. Jasper agate.

1. Landscape agate, appears to be composed of jasper, chalcedony, and hornstone.
2. Ribbon and zoned agate, are to be considered the same, the difference in colour delineation being produced by the particular direction in which the stone is cut. When it is cut perpendicular or oblique to the layers of which it is composed, ribbon agate is formed; but, when parallel with the layers, we obtain zoned agate. It is formed by the disposition of the layers on a pyramidal inequality, which is generally quartz.
3. Moss agate. Here jasper of various colours, as brown, yellow, &c. appears swimming in a chalcedonic basis. The jasper resembles moss, and when its arborations are distinct is very beautiful. Its mode of formation appears to be different from the preceding; according to Werner it has been formed more by a kind of gelatinisation, than by a successive deposition.
4. Tube or tubular agate, is composed of tubes of chalcedony and carnelian, and sometimes jasper, which are commonly filled with another fossil. When it is cut transversely it exhibits a circular or zoned delineation, but the zones are not so distinct as in the zoned agate, and the circle is produced

produced by a transverse, not by a perpendicular section, as is the case with the zoned agate. It is found in the manner of stalaçtite.

6. Clouded agate. The clouded markings are not sharp, and the colours run into each other. Its mode of formation is probably the same with the moss agate.
7. Star agate and coral agate, are to be considered as intermediate kinds between zoned and fortification agate.
8. Punctated agate. In this, which is one of the most beautiful species, points of jasper having various colours, as red, yellow, brown, &c. are dispersed through a chalcedonic basis. The red points in heliotrope are not essential to it, therefore it does not belong to this species.
9. Petrefaction agate. This is wood penetrated with several of the fossils that constitute agate.
10. Fragment agate. This beautiful variety is composed of fragments of different kinds of agate or of chalcedony, carnelian, &c. cemented by a fine flinty basis.
11. Jasper agate. Jasper, which in this variety is the principal constituent part, is intermixed with chalcedony. It has sometimes, also, silver interspersed.

Formation of Agate.

As the explanation of the modes of formation of the different kinds of agate, given by Werner, is interesting, I shall here give a short statement of it.

First, respecting those kinds that occur in amygdaloid: He supposes, that during the deposition of amygdaloidal rocks, a considerable quantity of air was evolved, which, in endeavouring to escape, formed cells, into which siliceous matter passed by infiltration, and formed agate. These cells, he supposes, were filled, not by one, but from several successive stony solutions, which deposited their contents, and thus formed thin coats of jasper, carnelian, chalcodony, &c. The inspection of these agates shews, that the first precipitate has been the coarsest, but that the successive ones have continued to increase in fineness until out of the last or finest solution amethyst has shot, or when it has had room enough has crystallized. That the solution out of which these precipitates took place was truly chemical, is shewn, not only by the appearance of the substances themselves, but also by the mode of their deposition, as they follow accurately the inequalities on the surface of the cavities, so that an elevation on the interior wall continues to be observed through all the superincumbent coats to the centre. When specimens of this kind are cut in

a proper direction, we can always observe the opening by which the solution has entered*.

Ribbon agate is formed in veins, and has been formed by deposition from different solutions.

The mode of formation of breccia or fragment agate is different from that of either of the preceding. If a completely formed agate vein is (again) rent, it is easily conceivable, from the great brittleness of the stone of which it is composed, that many pieces would break off, and fall into the numerous openings thus formed. A new solution being poured into these rents would fill them up, and connect together all the fragments, and thus a brecciated agate would be formed.

In a similar manner are formed the smaller and greater angular lengthened drusy cavities of quartz and amethyst, that occur in agate.

Similar rents, but on a smaller scale, are to be observed in ribbon agate, and these are generally filled with quartz and amethyst.

* Many objections have been opposed to this explanation, but the only one worthy of notice is the following. If the cavities have been filled by infiltration, it is demanded, how can we explain the escape of the water after the deposition of the stony matter? To this it may be answered, that as soon as the dissolved matter was deposited, the water which held it in solution, from its less specific gravity, would be displaced by the heavier new solution, and escape by the infiltration opening.

Geographic Situation.

No country affords finer agates, or in greater abundance than Germany: It would be useless to mention all its German localities; it is sufficient to observe, that it is found in great quantity at Oberstein, where several thousand persons are employed in quarrying, sorting, cutting and polishing it. It is also found in France, England, Scotland, and Ireland, and very beautiful in the East Indies, where, however, it is confounded with onyx.

Use.

Its uses are very various; sometimes it is cut into vases, mortars, snuff boxes, sometimes into plates for inlaying in tables; when it is very handsome it is used for seal stones, and then it is usually set with a blue or gold foil; and the smaller pieces are used for gun flints, for which it is often excellently suited.

It was highly valued by the ancients, who executed many fine works in it, which are now never attempted. It is only in the cabinets of the rich that such pieces of ancient work are to be seen; the collections of Brunswick and Dresden are remarkable for beautiful specimens of this kind.

T W E N T Y - S I X T H S P E C I E S .

Heliotrope.

Heliotrop.—*Werner*.

Jaspis variegata, heliotropius, *Wall.* t. 1, p. 315.—Heliotrop, *Wid.* f. 316.—Heliotropium, *Kirw.* vol. 1. p. 314. *Estner*, b. 2. f. 389. *Id. Emm.* b. 1. f. 171.—Eliotropio, *Nap.* p. 193.—Jaspe sanguin, *Lam.* t. 2. p. 166.—L'Heliotrope, *Broch.* t. 1. p. 276.—Quartz—agate, verd obscur & quartz—jaspe sanguin, *Hauy*.

External Characters.

Its principal colour is intermediate between leek and dark seladon green, or mountain green, and is always deep. Some varieties pass from leek green nearly into pistacio and olive green; others are marked with blood and scarlet red, also with ochre yellow and yellowish brown spots of jasper.

It occurs massive, in angular pieces, and rolled pieces.

Internal lustre is glistening, and nearly resinous.

Fracture imperfectly large conchoidal.

Fragments indeterminately angular and sharp edged.

It is commonly translucent on the edges, some varieties even passing into translucent.

Easily frangible.

Hard.

Not particularly heavy.

Specific gravity—2,633, *Blumenbach*.—2,620 to 2,700, *Kirwan*.

Geognostic Situation.

It is found in rocks belonging to the floetz trap formation, and probably occurs in the same kind of repository as chalcedony.

Geographic Situation.

In Asia, it is found in Bucharia, Persia, and Siberia; in Europe, it has been discovered in Iceland, and also in Upper Saxony.

Uses.

Its beautiful colour and considerable hardness cause it to be employed for nearly the same purposes as agate. That which has the greatest degree of translucency and most numerous red points, is the most highly valued.

Observation.
 A specimen of this species of flint, which is found in the same kind of repository as chalcedony, is said to be the most valuable of the kind. It is used for the same purposes as the other.

Observation.

Werner is of opinion that it is an intimate combination of chalcedony with green earth.

 TWENTY-SEVENTH SPECIES.

Plasma.

Plasma.—*Werner.*

Id. Emm. b. 3. f. 322. Id. Broch. t. 1. p. 278.

External Characters.

Its most common colour is intermediate between grass and leek green, and of different degrees of intensity; sometimes it approaches to mountain green. It is marked with ochre yellow dots and whitish spots. The white spots are very characteristic of this species.

Occurs in indeterminately angular pieces, which have a rough earthy crust.

Internally

Internally its lustre is glistening, verging on glimmering*.

Fracture perfectly flat conchoidal.

Fragments indeterminately angular, and very sharp edged.

It is intermediate between semitransparent and strongly translucent.

Hard, nearly in the same degree as chalcedony.

Brittle.

Not very difficultly frangible.

Not particularly heavy; somewhat lighter than heliotrope.

Geognostic and Geographic Situations.

Its geognostic situation is not known, and it has been hitherto only found among the ruins of Rome†.

Use.

It was worn by the Romans as a part of ornamental dress.

* When it shews more lustre it is owing to handling.

† Brochant quotes from Emmerling several other localities; these, however, apply to varieties of chalcedony, not to Plasma.

TWENTY-EIGHTH SPECIES,

Chryfopras.

Krifopras.—*Werner*.

Achates—prafius, *Wall.* t. 1. p. 292.—Chryfoprafe, *Rome d. L.* t. 2. p. 167.—Krifopras, *Wern. Cronft.* p. 99. *Id. Wid.* p. 356.—Chryfoprafium, *Kirw.* vol. 1. p. 284.—Chryfopras, *Elner*, b. 2. f. 349. *Id. Emm.* b. 1. f. 174.—Krifoprafio, *Nap.* p. 195. *Lam.* t. 2. p. 177.—La Chryfoprafe, *Brock*, t. 1. p. 280.—Quartz—agate prafe, *Hauy*.

External Characters.

Its characteristic colour is apple green, which is of all degrees of intensity; it paffes into grafs and light pistacio and olive green, and laftly into greenifh grey. The apple green fometimes inclines to verdgris green. It is fometimes alfo marked with brownifh fpoats.

It is found mafive, in angular pieces, and thick plates.

Internally it is dull; fome rare varieties are glimmering.

Its characteristic fracture is even; some varieties run into small and fine splintery; others, very rarely, into flat conchoidal.

Fragments indeterminately angular, more or less sharp edged.

It is intermediate between translucent and semi-transparent, but always approaches more to the first.

Hard, but in a lower degree than chalcedony.

Not particularly difficultly frangible.

Not particularly heavy.

Specific gravity.—3,250.

Chemical Characters.

Before the blow pipe it loses its colour and transparency, and is infusible without addition.

Constituent Parts.

Silica	96,16
Lime	0,83
Oxyd of nickel	1,00

And a trace of Alumina and Oxyd of Iron.

Klaproth, t. 2. p. 133.

Geognostic Situation.

It is found along with quartz, opal, chalcedony, albest, lithomarge, &c. in serpentine.

Geographic Situation.

It has been hitherto found only at Kofemutz in lower Silesia.

Use.

It is principally used for ring stones, but is rather difficult to cut and polish. The apple green variety is the most highly valued, and ring stones of that colour are usually valued at 12l.

Observations.

1. It passes into hornstone and chalcedony, and into a fossil which is intermediate between chrisopras and opal.

2. It loses much of its colour, when long kept in a warm and dry place, or when much exposed to the influence of the air; on this account mineral dealers are careful to preserve their specimens in moist places.

3. It is often confounded with green opal, from which it differs, however, in fracture, lustre, hardness and weight.

4. May not chrysopras, plasma, and heliotrope, as well stand under chalcedony, as milk quartz and prase under quartz?

5. Very elegant specimens of this beautiful fossil are to be seen in the great cathedral at Prague, where a closet is inlaid with it.

TWENTY-NINTH SPECIES.

Flinty Slate.

Kiefelschiefer.—*Werner*.

This species is by Werner divided into two subspecies. 1. Common flinty slate. 2. Lydian stone.

FIRST SUBSPECIES.

Common Flinty Slate.

Gemeiner Kiefelschiefer.—*Werner*.

Id. Wid. f. 380.—Siliceous schistus, *Kirw.* vol. I, p. 306.—
Kiefelschiefer, *Efner*, b. 2. f. 343. *Id. Emm.* b. I. f. 178.
—Schisto filiceo, *Nap.* p. 244.—Schiste filicieux com-
mun. *Broch.* t. I. p. 283.

External Characters.

Its principal colour is grey, of which the following varieties occur: ash grey, which passes into blueish grey, from blueish grey into pearl grey, and cherry red, which approaches to blood red.

It is pretty often flamed and spotted, seldomer striped, and irregularly clouded.

It is often traversed by quartz veins.

It occurs massive, in whole beds, and frequently in blunt angled pieces, which have a smooth and glimmering surface.

Internally it is faintly glimmering, and almost dull.

Fracture in the great is generally imperfectly flaty, and in the small is intermediate between splintery and uneven, and sometimes inclines to flat conchoidal.

Fragments indeterminately angular and pretty sharp edged.

It sometimes occurs in lamellar distinct concretions.

It is more or less translucent, and passes into translucent on the edges.

Hard. *as quartz*

Brittle. *as quartz*

Difficultly frangible.

Not particularly heavy.

Geognostic Situation.

It occurs in beds in transition mountains, and probably also in some floetz formations.

Sometimes traversed by quartz veins

Geographic Situation.

It is found in Saxony, Harz, and in various parts of the great tract of transition rocks in the south of Scotland, as at Lead Hills, Carlips, and Moorfoot Hills, near Edinburgh.

SECOND SUBSPECIES,

Lydian Stone.

Lidifcherstein.—*Werner*.

Lapis Lydius, *Wall.* t. 1. p. 353.—L. Stein, *Wid.* p. 360.
 Bafanite, *Kirw.* vol. 1. p. 307.—Lidifcherstein, *Estner*,
 b. 2. f. 346. *Id.* *Emm.* b. 1. f. 181.—Schisto filicio,
Nap. p. 244.—Lydienne, *Lam.* t. 2. p. 384.—La pierre
 de Lydie, *Broch.* t. 1. p. 286.

External Characters.

Its colour is greyish black, which passes into velvet black.

It occurs massive, and is also frequently found in trapezoidal shaped rolled pieces, with rounded angles.

It is, like the preceding subspecies, traversed by quartz veins.

The external surface is smooth and glistening.

Internally it is glimmering.

Fracture is perfectly even, and approaches sometimes to the flat conchoidal, sometimes to the uneven.

Fragments are indeterminately angular, more or less sharp edged, and approach sometimes to the cubical shape.

Opaque.

Opaque.

Hard, but not in a high degree,

Pretty easily frangible,

Not particularly heavy.

Geognostic Situation.

It is found in similar formations and repositories with flinty slate.

Geographic Situation.

Found near Prague and Carlsbad in Bohemia; at Hainchen near Freyberg in Saxony; in the Harz, and in the Moorfoot and Pentland Hills, near Edinburgh.

Use.

When polished, it is used as a test stone, for determining the purity of gold and silver: owing, however, to its great hardness, it is less suited for this purpose than basalt, and some varieties of clay slate.

Observations.
 A little
 by covering some Carlsbad

Observations.

Observations.

1. Basalt, and certain compact varieties of clay slate, are what many of the French mineralogists consider to be Lydian stone.

2. Humboldt, from a series of experiments which he made on this fossil, asserts that it contains a portion of carbone, which is also countenanced from geognostic data.

3. It is said to have been first found in the province of Lydia in Lesser Asia, whence its name.

THIRTIETH SPECIES.

Cat's-eye.

Katzenauge.—*Werner*.

Pseudopalus opacus radios—*Oculus cati*, *Wall.* t. 1. p. 296.
 —*Oeil de chat*, *R. d. L.* t. 2. p. 145.—Variety of *mondstein*, or *Adularia*, *Wid.* p. 344.—*Cat's-eye*, *Kirw.* vol. 1. p. 301.—*Katzenauge*, *Emm.* b. 1. f. 188.—*Occhio di gatto*, *Nap.* p. 225.—*Oeil de chat*, *Lam.* 2. p. 152. *Id. Broch.* t. 1. p. 292.—*Quartz agathe chatoyant*, *Hauy*.

External Characters.

Its principal colour is grey, of which it presents the following varieties: yellowish, greenish, and ash grey; from yellowish grey it passes into yellowish brown, and into a kind of isabella yellow; and further into yellowish, reddish, and hair brown, and into a colour intermediate between hyacinth and brick red. From greenish grey it passes into mountain green and olive green; and from ash grey into greyish black.

It is found in blunt edged pieces, in rolled pieces, and also massive*.

* It is usually brought into Europe cut.

Internally

Internally it is shining, and intermediate between vitreous and resinous.

Fracture small and a little imperfectly conchoidal, sometimes approaching the uneven.

Fragments indeterminately angular, and more or less sharp edged.

It is commonly translucent, sometimes also semi-transparent, and in other varieties only translucent on the edges.

It sometimes presents slender white rather opaque fibres that are parallel to each other; the particular appearance, which is termed chatoyant, is produced by the reflection of the rays of light from these fibres.

Hard.

Easily frangible.

Not particularly heavy.

Specific gravity—From 2,625 to 2,600, *Klaproth.*

Chemical Characters.

By exposure to the heat of a porcelain furnace it loses its hardness, lustre, and transparency, and partly its colour, but is not melted. Before the blow pipe, according to Sauffure, it melts with great difficulty.

Constituent Parts.

Silica	95,00	94,50
Alumina	1,75	2,00
Lime	1,50	1,50
Oxyd of Iron	0,25	0,25
Loss	1,50	1,75
	<hr/>	<hr/>
	100	100

*Klaproth, t. I. p. 94.**Geognostic Situation*

Is unknown.

Geographic Situation.

It is brought to us from the island of Ceylon, and the coast of Malabar.

Use.

It is usually cut for ring stones, and the red coloured variety is the most highly valued.

Observation:

Observation.

It has been by some mineralogists referred to opal, by others to felspar; it is, however, sufficiently distinguished from opal by its hardness and weight; its fracture distinguishes it from felspar.

*It is however, it seems to be of a
quality, from fibres of at least*

THIRTY-FIRST SPECIES.

Prehnite.

Prehnite, *Werner*.

Wid. f. 357. *Id. Kirw.* vol. 1. p. 274. *Id. Estner.* b. 2. f. 488. *Id. Emm.* b. 1. f. 192.—Prehnite, *Nap.* p. 235. *Lam.* t. 2. p. 311.—La Prehnite, *Broch.* t. 1. p. 295. *Id. Haüy,* t. 3. p. 167.

External Characters.

Its colours are greenish white, greenish grey, mountain green, and apple green, which latter sometimes approaches to grass green; also yellowish grey and yellowish green.

It is sometimes massive, sometimes crystallised in oblique four-sided tables, which are pretty often truncated on the acuter angles. When these truncations increase, a longish six-sided table is formed; when this table becomes thicker, there is formed a four-sided prism bevelled on both extremities, the bevelling planes are set on the smaller lateral planes, and the edge of the bevillment is truncated.

The

The crystals are either single, manipularly, or *wulzförmig*, aggregated *. In this latter kind of aggregation the lateral planes are so grown together that only the terminal planes are to be seen.

Sometimes the crystals are a little convex in the middle, owing to exfoliation. They are small and middle-sized.

Externally the crystals are smooth and shining, internally shining inclining to glistening, and pearly.

Fracture sometimes foliated with an imperfect single cleavage, also sometimes small scopiformly diverging radiated.

Fragments indeterminately angular, and wedge-shaped.

The foliated occurs in coarse and small grained distinct concretions; the radiated in wedge-shaped prismatic distinct concretions.

It is translucent, but sometimes passes into semi-transparent and transparent.

Hard †.

Easily frangible.

Not particularly heavy.

Specific gravity—Prehnite of the Cape, 26,969, *Haüy*; 2,942, *Briffon*; 2,9423, *Kirwan*.—Prehnite of France, 26,097, *Haüy*.

* I have not found a corresponding English term for the German *wulzförmig*.

† Scratches glass slightly. *Haüy*.

Chemical Characters.

Before the blow pipe it foams up equally, if not stronger than zeolite, but does not, like it, gelatinate with acids.

Constituent Parts.

	<i>Klaproth.</i>	<i>Hassenfratz.</i>
Prehnite of the Cape.		Of France.
Silica	43,83	50,0
Alumina	30,33	20,4
Lime	18,33	23,3
Oxyd of iron	5,66	4,9
Water	1,83	0,9
Magnesia		0,5
	<hr/>	<hr/>
	99,98	100

Beobacht und entdeck, II. p. 217.

J. d. P. Febr. 1788.

Geognostic and Geographic Situations.

It occurs in Dauphiny, in veins, of the oldest formation, that traverse greenstone slate; in Scotland, on the contrary, it is found in rocks belonging to the newest floetz trap formation, as at Edinburgh, in the basalt of the castle rock. It is also found in porphyritic greenstone, at Arthur's Seat, and at Frisky Hall,
between

between Glasgow and Dumbarton; and in floetz trap rocks in the Island of Mull *, and county of Ayr. It was first found among the mountains of southern Africa, by Colonel Prehn; it has since that time been observed in the same country by Mr Barrow; but we have as yet no account of its African geognostic situation.

Observations.

1. It was named Prehnite by Werner, in honour of a Dutch officer, Colonel Prehn, who first brought it from the Cape of Good Hope to Europe.

2. It has been described and mentioned under a variety of names, as chrysolite, emerald, prase, chryso-prase of the Cape, &c.

* Mineralogy of the Scottish Isles.

THIRTY-SECOND SPECIES.

Zeolite.

Zeolith.—*Werner.*

This species is divided by Werner into five sub-species, *viz.* 1. Mealy zeolite, 2. Fibrous zeolite. 3. Radiated zeolite, 4. Foliated zeolite, and 5. Cubic zeolite.

They are principally distinguished from each other by fracture, hardness, and lustre.

Some with Zeolith

Zeolith

Zeolith

Zeolith

Zeolith

Zeolith

some have a mealy aspect.

Zeolith Zeolith 211 0 0

FIRST SUBSPECIES.

Mealy Zeolite.

Mehlzeolith.—*Werner*.

Id. Wid. p. 361.—Zeolite, *Kirw.* t. 1. p. 278.—Mehlzeolith, *Efner*, b. 2. f. 481. *Id. Emm.* b. 1. f. 199.—Zeolite compatta terrea, *Nap.* p. 235.—Zeolithe terreufe, or mefotype, *Haüy*.—La zeolite farineufe, *Broch.* t. 1. p. 298.

External Characters.

Its colours are yellowifh and reddifh white; the latter fometimes paffes to pale flefh red, and even approaches to brick red.

It occurs mafive, coralloidal, and fometimes it forms a cruft over the other fubfpecies of zeolite.

Internally it is dull.

Fracture coarfe earthy; but when it verges on the fibrous, approaches to delicately fibrous.

Fragments indeterminately angular blunt edged.

Opaque.

Very foft, paffing into friable,

Eafily frangible,

Light,

When the finger is made to pass across it, it emits a grating sound, not unlike that of burnt brick.

Constituent Parts.

Silica	50,0
Alumina	20,0
Lime	8,0
Water	22,0

100,0

According to *Pelletier. J. d. P. t. 22, p. 420.*

Geognostic Situation.

It occurs in similar repositories with the other species, *and is often associated with the other species which it covers in form of a shell.*

Geographic Situation.

It is found in Iceland, Faroe Islands, Sweden, and in various parts of Scotland, particularly in the Isle of Skye *, and near Tantallon Castle in Berwickshire.

* Mineralogy of the Scottish isles.

SECOND SUBSPECIES.

Fibrous Zeolite.

Fafriger Zeolith.—*Werner*.

Gemeiner zeolite, *Wid.* p. 363.—Zeolith, *Kirw.* p. 278.
 Strahliger zeolith, *Emm.* b. 1. f. 200.—Zeolith com-
 mune, *Nap.* p. 228.—Zeolithe fibreuse, *Broch.* t. 1.
 p. 299.—Mefotype, *Hauy*, t. 3. p. 151.

External Characters.

Its colours are snow white, yellowish white, greenish white, and reddish white; from yellowish white it passes into a colour intermediate between wax and ochre yellow; from greenish white into greenish grey, and from reddish white into flesh red. Green is the rarest colour, and yellow occurs but seldom.

It occurs not only massive, but also in angular pieces, in balls, small reniform, and in capillary crystals.

Internally its lustre is glimmering, which borders on glistening, and is pearly.

Fracture delicately and coarsely fibrous, straight, and stellularly and scopiformly fibrous, also splintery.

Fragments wedge shaped.

It occurs in large and coarse grained, sometimes in small grained distinct concretions.

Translucent.

Semi-hard in an inferior degree.

Brittle.

Easily frangible.

Intermediate between not particularly heavy and light. *Fracture granular about 200*

Constituent Parts.

Silica	41,0
Alumina	31,0
Lime	11,0
Water	15,0

According to *Meyer*.

Its geognostic and geographic situations are the same with the following subspecies.

THIRD SUBSPECIES.

Radiated Zeolite.

Strahliger Zeolith.—*Werner*.

Id. Wid. p. 363. *Id. Emm.* b. 1. f. 202.—Zeolite commune, *Nap.* p. 228.—Zeolite, first variety, *Lam.* t. 2. p. 305.—Zeolithe rayonnée, *Broch.* t. 1. p. 301.—Mefotype, *Hauy*.

External Characters.

It only occurs yellowish, greyish, reddish, and snow white.

It is found massive, globular, also frequently crystallised.

1. In very broad rectangular four-sided prisms, acuminate on both extremities by four planes, which are set on the lateral edges; and the extremity of the acumination is often truncated. When the plane of truncation increases very much, it forms a terminal plane, and the acuminate planes form truncations on the angles.

2. In

2. In rectangular four-sided prisms, acuminate on both extremities by four planes, which are set on the lateral planes: sometimes the prisms are so thin that they may be viewed as longish six-sided tables, bevelled on their four smaller terminal planes; sometimes two of the terminal planes became so large as nearly to form an oblique four-sided table.

The crystals are often manipularly aggregated, and frequently so grown together that the acuminations only are visible, and project like pyramids. The crystals are middle sized and small. The broader lateral planes are smooth, and longitudinally sheathed.

External lustre shining, approaching to splendid and pearly. Internally glistening and completely pearly.

Fracture narrow and broad, straight and curved, and stellularly and scopiformly diverging—radiated. The broad radiated borders on the foliated, and the narrow on the fibrous fracture.

Fragments sometimes indeterminately angular, sometimes wedge-shaped.

It occurs in large and coarse, even sometimes approaching to the small grained, longish distinct concretions.

It is translucent; the crystals are sometimes semi-transparent and duplicating transparent*.

* Haüy.

Semi-hard*.

Brittle.

Easily frangible.

Not particularly heavy, passing into light.

Specific gravity—From 2,035 to 2,488, *Bergman*.—
2,0833, *Haüy*.

Constituent Parts.

Silica	52,0
Alumina	17,5
Lime	9,0
Water	18,5
Loss	3,0

100,0

According to *Vauquelin*, *J. d. M. N.* 39, p. 164.

* Scratches calc spar. *Haüy*.

FOURTH SUBSPECIES.

Foliated Zeolite.

Blättriger Zeolith.—*Werner*.

Gemeiner Zeolith, *Wid.* p. 363—Zeolith. *Kirw.* vol. 1. p. 278.—Blättriger Zeolith. *Emm.* b. 1. f. 204.—Zeolite commune, *Nap.* p. 228.—Zeolithe nacrée, *Lam.* t. 2. p. 305.—Zeolithe lamelleuse, *Broch.* t. 1. p. 302.—Stilbite, *Haüy**.

External Characters.

Its colour is almost always yellowish and greyish white, seldom snow and reddish white.

It occurs massive, globular, in amygdaloidal-shaped pieces, and also crystallized.

1. In short and very oblique, four-sided prisms, in which sometimes the lateral edges and angles are more or less deeply truncated.
2. When the truncations on the acuter lateral edges increase a six-sided prism is formed, and when these prisms become very short,

* The variety entitled Stilbite dodecaedre belongs to the radiated zeolite.

they appear as equilateral six-sided tables.

The crystals are small and middle-sized, and occur in druses, and their surface is smooth and splendid.

Internally its lustre is shining, which approaches to splendid, and is completely pearly.

Fracture perfectly foliated, the folia a little curved, with a simple cleavage: sometimes it is conchoidal.

Occurs in large, coarse, and small grained distinct concretions, seldom in lamellar, a little curved distinct concretions, nearly resembling straight lamellar heavy spar.

The massive is very strongly translucent, but the crystals are semitransparent, sometimes even transparent.

Semi-hard.

Easily frangible.

Intermediate between not particularly heavy and light.

Constituent Parts

Silica 58,3

Alumina 17,9

Lime 6,6

Water 17,5

Loss 3,9

100,05th

According to Meyer According to Vauquelin.

FIFTH SUBSPECIES.

Cubic Zeolite.

Wurfel Zeolith.—*Werner.*

Zeolith cubique, *Lam.* t. 2. p. 307.—Chabasie, and analcime, *Haüy*, t. 3. p. 180. and 176.—La zeolithe cubique, *Broch.* t. 2. p. 304.

External Characters.

Its colour is greyish white, bordering on yellowish white; also reddish brown.

Occurs massive, but most commonly crystallized.

1. Perfect smooth planed cube.
2. The cube acuminate on each angle by three planes which are set on the lateral planes.
3. When the acuminate planes in the preceding variety increase so much as to cause the original faces of the cube to disappear, a 24-sided figure, resembling that of the leuzite, is formed.

Crystals penetrate, and sometimes are aggregated on each other, and they are small and middle sized.

Externally

Externally its lustre is splendid and intermediate between pearly and vitreous. Internally it is shining.

Fracture very imperfectly foliated, cleavage three-fold, and the folia intersect each other under right angles, and parallel with the planes of the cube. Sometimes also passes into coarse grained uneven.

Fragments indeterminately angular, approaching to cubical.

Has a tendency to coarse and fine grained distinct concretions.

Alternates from translucent to transparent.

Semi-hard, but in a higher degree than the preceding subspecies*.

Not particularly heavy.

Specific gravity.—2,716, *Hauy*.

Chemical Characters.

Before the blow pipe it intumesces like borax, and melts easily into a cellular glass, and during fusion emits a phosphoric light. With acid it forms a jelly†.

* Scratches glass slightly.—*Hauy*.

† It is distinguished from leuzite, by its easy fusibility.

Observations.

1. Haüy has formed of this subspecies two distinct species, but without sufficient reason.
2. The leuzitic crystallization of cubic zeolite is considered by Reufs and other mineralogists as identical with leuzite. Independent of its different external character, however, the cubic zeolite is geognostically distinguished from leuzite. Leuzite occurs in crystals, which are all around crystallized, or in grains, both of which are imbedded, and consequently of contemporaneous origin with the rock in which they are found. The cubic zeolite, on the contrary, is found covering the walls of air cells in amygdaloid, therefore is of posterior origin to the rock in which it occurs.

Geognostic Situation of Zeolite.

In general it occurs in rocks belonging to the latest formation, particularly in those of the newest floetz trap, as amygdaloid, basalt, wacce, porphyry slate, and greenstone. It is also, although rarely, found in primitive greenstone*.

* In the royal cabinet of minerals at Berlin I saw specimens of primitive greenstone, from Sweden, containing zeolite.

Occurs either disseminated, in cotemporaneous balls, or lining or filling up air cavities or veins. At Strontian the foliated zeolite is found in mineral veins along with lead glance and stromantian; the same variety occurs in lead veins in the Harz; and, according to Hauy, the cubic zeolite is found at Oberstein in the interior of agate druses.

Geographic Situation of Zeolite.

All the different subspecies of zeolite are found in Scotland. The mealy zeolite, as already mentioned, occurs in the island of Skye, and in the rocks opposite the Bafs in Berwickshire: the fibrous and radiated subspecies are found in the islands of Cannay and Skye; the foliated in Staffa, and the cubic in Staffa, and near Talyfker in the island of Skye*. They are also met with uncommonly fine in the island of Iceland, the Farroe isles, and in several places in Sweden, as at Adelfors, &c. In Germany, they are found in the Harz; Bohemia, Heflia, Tyrol, Transylvania, and in the East Indies, as in the island of Elephanta†.

* Mineralogy of the Scottish isles.

† I have specimens from Elephanta.

Handwritten note: A zeolite. See also 521

THIRTY-FIRST SPECIES.

Cross Stone.

Kreuzstein.—*Werner*.

Hyacinth blanche cruciforme, *R. d. L.* t. 2. p. 299.—
Staurolite, *Kirw.* v. 1. p. 282. *Estner*, b. 2. f. 499. *Id.*
Emm. b. f. 209.—Ercinite, *Nap.* p. 239.—Andreolithe,
Lam. t. 2. p. 285.—Harmotome, *Hauy*, t. 3. p. 191.—
Pierre Cruciforme, *Broch.* t. 1. p. 311.

External Characters.

Its colour is greyish white.

It occurs crystallized.

1. In broad rectangular four-sided prisms, acuminated by four planes which are set on the lateral edges.
2. In twin crystals, which are formed by two of the crystals No. 1. intersecting each other with their broader planes in such a manner that a common axis and acumination is formed, and the broader lateral planes make four right angled re-entering angles.

The crystals are almost always small, and aggregated on one another; surface smooth or drusy.

Both

Both internal and external lustre is shining, which sometimes inclines to splendid, sometimes to gliftening, and is intermediate between pearly and vitreous.

Cross fracture uneven and sometimes also small conchoidal, but in other directions foliated.

Fragments indeterminately angular.

Translucent, passing to transparent.

Semi-hard, somewhat more than zeolite*.

Easily frangible, *Brittle*

Not particularly heavy.

Specific gravity—2,355 to 2,361, *Kirwan*—2, 353
Heyer.—2,333, *Hauy*.

Chemical Characters.

Lelievre asserts that it is fusible without addition into a white transparent glass, before the blow pipe. Other chemists affirm that it is completely infusible without addition. It does not form a jelly with acids, and, according to *Hauy*, when powdered and thrown on charcoal emits a greenish yellow phosphoric light.

* Scratches glass easily.—*Hauy*.

<i>Constituent Parts.</i>			
Silica	44	44 to 47	49
Alumina	20	20 to 12	16
Baryt	24	25 to 20	18
Water	12	16 to 16	15
Iron		4	
	100	100 99	98
	<i>Heyer.</i>	<i>Wefstrumb.</i>	<i>Klaproth.</i>

Geognostic and Geographic Situations.

It has been hitherto found only in mineral veins, and in agate balls. At Andreasberg in the Harz it occurs in veins accompanied with quartz, calc spar, lead glance, copper pyrites, iron pyrites, fahle ore, &c. and generally occurs in druses, and of all the materials of the vein it is the newest. Strontian in Argyleshire is the only other place where it has been observed in veins. At Oberstein it occurs in single crystals in agate balls, according to Haüy.

THIRTY-SECOND SPECIES.

Azure Stone.

Lazurstein.—*Werner*.

Zeolithes particulis &c. Lapis lazzuli, *Wall.* t. 2. p. 326.
 —Lapis lazzuli, *R. d. L.* t. 2. p. 49.—Lazurstein, *Wid.*
 p. 371.—Lapis lazuli, *Kirw.* vol. 1. p. 283.—Lapis laz-
 zoli, *Nap.* p. 241. — Lazulite, *Lam.* t. 2. p. 185. — La
 pierre d'azur, *Broch.* t. 1. p. 313.—Lazulite, *Hauy*, t. 3.
 p. 145.

External Characters.

Colour perfect azure blue; in some varieties it
 passes into Berlin blue, even sometimes approaches
 to sky blue; and other varieties occur smalt blue of
 all degrees of intensity.

It is found massive, disseminated, and in rolled
 pieces.

Lustre glistening and glimmering.

Fracture fine grained uneven.

Fragments indeterminately angular, not particu-
 larly sharp-edged.

Translucent on the edges.

Pretty hard*.

* Scratches glass.—*Hauy*.

Brittle.

Easily frangible.

Not particularly heavy.

Specific gravity—2,771, *Blumenbach*.—2,767 to 2,945, *Hauy*.—2,896, *Kirwan*.

Chemical Characters.

Before the blow pipe it loses its colour, and melts into a whitish enamel. When previously calcined and powdered, it forms a gelly with acids.

Constituent Parts.

Silica	46,0
Alumina	14,50
Carbonate of Lime	28,0
Sulphat of lime	6,50
Oxyd of iron	3,0
Water	2,0
	—
	100

Klaproth, b. i. f. 196.

Geognostic Situation.

Its geognostic situation has not been satisfactorily ascertained. It is said to have been found near to
the

the lake Baikal in Siberia, in a vein accompanied with garnets, felspar, and pyrites. Werner suspects that it occurs in rock masses.

The fragments we have an opportunity of examining are generally intermixed with iron pyrites, felspar, and quartz.

Geographic Situation.

In Asia, it has been found in Persia, Bucharia, China, Great Tartary, and Siberia. Mr Pennant, in his Outlines of the globe informs us that it is found in considerable quantities in the island of Hainan in the Chinese Sea, from whence it is sent to Canton, where it is employed in china painting.

In America, it is said to have been found at Atakama in Chili.

In Europe, it has been only found among the ruins of Rome.

Uses.

On account of its beautiful blue colour, and the fine polish it is capable of receiving, it is worked into various articles of dress, as ring stones, seal stones, snuff boxes, &c.: it is also used for ornamenting altars, in mosaic and florentine work. It is highly valued by painters, on account of the fine ultramarine blue colour which is prepared from it.

Observations.

It is found in Persia, Bucharia, China, Great Tartary, and Siberia.

Observations.

1. The European azure stone is either blue felspar or copper azure.
2. It is described by Pliny in the 10th chapter of the 37th book of his Natural History, as a variety of sapphire.
3. The greater number of writers have followed Cronstedt in considering it as a kind of zeolite. Others have referred it to the calc genus, and some have even placed it among the ores of iron. Werner long since considered it as a distinct species, and, from its external characters, gave it its present place in the system.

Lazulite.

La lazulithe, *Broch* t. 1. p. 315.

Is a fossil which has been analyzed by Klaproth, and by some mineralogists considered as a distinct species*.

* As we have no good description of this fossil, it is not in my power to give any account of it in this volume.

FOURTH GENUS.

CLAY GENUS.

FIRST SPECIES.

Jasper.

Jaspis.—*Werner.*

Werner divides this species into six subspecies, viz. 1. Egyptian jasper, 2. Striped jasper, 3. Porcelain jasper, 4. Common jasper, 5. Agate jasper, and 6. Opal jasper.

FIRST SUBSPECIES.

Egyptian Jasper.

Egyptischer Jaspis.—*Werner*.

Silex ægyptiacus, *Wall.* t. 1. p. 276.—Egyptian pebble, *Kirw.* vol. 1. p. 312.—Egyptischer jaspis, *Emm.* b. 1. f. 234.—Caillou d'Égypte, *Lam.* t. 2. p. 166.—Le jaspe Égyptien, *Broch.* t. 1. p. 332.

External Characters.

Its colours are chestnut brown, yellowish brown, isabella yellow, and yellowish grey; also blood red and brownish red, and these latter are marked with ochre yellow and yellowish brown delineations.

It is characteristic of this fossil that the interior is of a yellowish grey colour, which often passes into isabella or cream yellow, but towards the exterior is yellowish brown and chestnut brown. The brown colour makes concentric circular delineations, and between these it is spotted with black, and between the spots are small arboresecent delineations of the same colour.

Occurs

Occurs in rolled pieces, which are mostly spherical, and their surface intermediate between uneven and rough.

Externally it is glistening, approaching to glimmering; internally it is glistening.

Fracture pretty perfectly, somewhat flatly, conchoidal.

Fragments indeterminately angular, sharp edged.

A little translucent on the edges.

Hard, *very impure as seen in quartz*

Pretty easily frangible.

Not particularly heavy.

Specific gravity—From 2,600 to 2,564.

Chemical Character.

Before the blow pipe it is infusible without addition.

Geognostic Situation.

It has been hitherto found only in rolled pieces. Werner suspects that it occurs imbedded in a brown ochre of iron*.

* Brochant informs us that his friend Cordier, while in Egypt observed this, along with other flinty stones, constituting a breccia, which formed the basis of a great part of Egypt and the neighbouring African deserts. Does this breccia belong to the flötz trap formation?

Geographic

Geographic Situation.

It is found in Egypt.

Use.

On account of its beautiful colour delineations, and considerable degree of hardness, it is used for similar ornamental and useful purposes as agate.

SECOND SUBSPECIES.

Striped Jasper.

Band Jaspis.—*Werner*.

Striped Jasper, *Kirw.* vol. 1. p. 312.—Band Jaspis, *Emm.*
b. 1. f. 237. — Jafpe rubane, *Lam.* p, 165. — Le Jafpe
rubane, *Broch.* t. 1, p. 334.

External Characters.

Its colours are grey, green, yellow, and red. Of grey it presents the following varieties, pearl grey, greenish grey and yellowish grey: Of yellow, cream yellow, which passes into straw yellow: Of green, mountain green, which passes into leek green and greenish grey: Of red, cherry red, brownish red, and flesh red; the cherry red passes into plumb blue.

There are always several colours together, and these are arranged in striped and flamed delineations.

Always massive.

Internally it is dull, when an admixture of foreign ingredients does not give a slight degree of lustre.

Fracture pretty perfectly conchoidal, approaching somewhat to the fine earthy; sometimes it shews a tendency to the flaty, and according to this the co-

four delineations are distributed. Sometimes it occurs small and fine splintery.

Fragments indeterminately angular, pretty sharp-edged.

A little translucent on the edges; sometimes opaque.

Pretty hard, but in a low degree.

Brittle.

Not particularly difficultly frangible.

Not particularly heavy.

Geognostic Situation.

It occurs in great beds, and in some countries, it even forms whole hills. It belongs to the floetz formations, and probably to the newer clay stone formation.

Geographic Situation.

It is found in Saxony, also in great quantity and very beautiful in Siberia; probably also, in the Pentland hills near Edinburgh.

Use.

It receives a good polish, and hence is used for ornamental purposes.

Observations.

Observations.

1. It derives its name from the striped colour delineations with which it is marked. The common name, ribbon jasper, is not appropriate. I have therefore employed Mr Kirwan's denomination, Striped Jasper.

2. Werner suspects that it is allied to conchoidal hornstone. He is also of opinion that its colour is not original, but produced by an infiltration of oxyd of iron.

This striped jasper has also been found in transition country, in Texas.

THIRD SUBSPECIES.

Porcelaine Jasper.

Porzellan Jaspis.—*Werner*.

Id. Wid. p. 314.—Porcellanite, *Kirw.* vol. 1. p. 313.—
 Porzellan-Jaspis, *Efner*, b. 2. f. 613. *Ibid Emm.* b. 1.
 f. 240.—Diaspro porcellanico, *Nap.* p. 192.—Jaspe por-
 celaine, *Lam.* t. 2. p. 166. *Ibid Broch.* t. 1. p. 166.—
 Thermantide porcellanite, *Häuy*, t. 4. p. 510.

External Characters.

Its colours are grey, yellow, blue and red. Of grey, it presents the following varieties, smoke, blueish, yellowish and pearl grey; from pearl grey it passes into lilac blue and lavender blue; also into brick red, which inclines to yellow; from yellowish grey it passes into straw yellow, and ochre yellow; from smoke grey into greyish black and ash grey.

It generally exhibits but one colour, and is sometimes marked with dotted, flamed, and clouded delineations.

The grey varieties are generally brick red in the rifts. It often presents brick red vegetable impres-
 sions;

sions; and this is most frequently the case with the lavender blue varieties.

Occurs most commonly massive, and in angular pieces, also frequently rent and bursten.

Internally its lustre is glimmering, sometimes glistering, and but seldom shining.

Fracture imperfectly large and flat conchoidal, also small conchoidal, which passes into uneven and earthy. Some rare varieties shew a tendency to the flaty fracture.

Fragments indeterminately angular and sharp edged.

Opaque.

Pretty hard.

Uncommonly brittle.

Not particularly heavy.

Chemical Character.

Before the blow pipe it melts without addition into a black scoria.

Constituent Parts.

Silica	60,75
Alumina	27,25
Magnesia	3,00
Oxyd of iron	2,50
Potash	3,66

According to *Rose*.

Geognostic Situation.

It occurs in whole beds in pseudo volcanic hills. Werner is of opinion that it is slaty clay converted into a kind of porcelain by the action of pseudo volcanic fires.

Geographic Situation.

It is found plentifully in Bohemia, in the neighbourhood of pseudo volcanoes.

*It is found in the country of
Bohemia more in a coal mine
than elsewhere. It is mineral*

FOURTH SUBSPECIES.

Common Jasper.

Gemeiner Jaspis.—*Werner*.

This subspecies *Werner* divides into two kinds.

a. Conchoidal common jasper. *b.* Earthy common jasper.

a. Conchoidal common Jasper.

External Characters.

It is most commonly brown and red, also yellow. Of brown it presents the following varieties; yellowish and liver brown, which latter sometimes passes into blackish brown; the yellow is always ochre yellow; the red is blood red, which rarely passes into scarlet red, and sometimes into cochineal red, but oftener into brownish red; black is brownish black.

Occurs generally with one colour; when several occur together, they are distributed into clouded, spotted, and striped delineations.

Occurs

Occurs most commonly massive, also finely disseminated in chalcedony, and moss-like in agate. The striped variety is sometimes imbedded in quartz.

Internally its lustre is shining, which approaches glistening, and is intermediate between vitreous and resinous.

Fracture more or less perfectly conchoidal, passing into even and fine earthy.

Fragments indeterminately angular, more or less sharp edged.

Usually opaque, seldom translucent on the edges, and that only when it approaches to jasper agate.

Pretty hard, but in a higher degree than the following kind.

Brittle.

Easily frangible.

Not particularly heavy.

b. Earthy common Jasper.

Its colours are blood red and brownish red; the latter passes into brown.

Occurs massive and in rolled pieces.

Fracture earthy.

Fragments indeterminately angular, not particularly sharp edged.

Opaque.

Pretty hard, but in an inferior degree,

Pretty easily frangible,

Not particularly heavy.

Geognostic Situation.

It is generally found in veins that occur in primitive rocks, and is a constituent part of those agates that are found in amygdaloid. It is frequently traversed by quartz veins, and is sometimes mixed with pyrites, lithomarge, semiopal, brown spar and native and vitreous silver ore. It has been supposed to form the basis of certain kinds of porphyry; but this is not the case; the basis of these porphyries, as Werner first observed, is either hornstone, indurated clay, or compact felspar.

Geographic Situation.

It is found in Saxony, Bohemia, France, Spain, Italy, Hungary, Russia, Sweden, Shetland islands*, and the transition rocks near Edinburgh.

* Mineralogy of the Scottish Isles.

FIFTH SUBSPECIES.

Jasper Agate.

Agate Jasper

Agat-Jaspis.—Werner.

External Characters.

Colour is yellowish white and reddish white ; the yellowish white passes into cream and straw yellow, and approaches to ochre yellow ; the reddish white passes into flesh red. The colours are distributed in ring-shaped delineations, also in fortification-wise bent stripes.

Occurs massive.

Has no lustre.

Fracture small and flat conchoidal, approaching to even.

Fragments indeterminately angular, not particularly sharp edged.

Generally opaque, sometimes translucent on the edges.

Pretty hard.

Often adheres to the tongue.

Not particularly heavy, approaching to light.

Geognostic Situation.

Occurs in agate balls, which are found in amygdaloid.

SIXTH SUBSPECIES.

Opal Jasper.

Opal Jaspis.—*Werner.*

External Characters.

Its colours are scarlet red, brick red, blood red, brownish red, and blackish brown, which latter approaches to liver brown, and rarely to ochre yellow.

Colour sometimes uniform, sometimes distributed in spotted, veined, and clouded delineations.

Occurs massive.

Internally its lustre is shining, approaching to splendid, and is intermediate between vitreous and resinous.

Fracture completely a little flat, conchoidal.

l i 2

Fragments

Its colours are comparatively bright

Fragments indeterminately angular, and very sharp edged.

Opaque, and sometimes translucent on the edges.

Intermediate between pretty hard and semi-hard.

Brittle.

Easily frangible.

Not particularly heavy, approaching to light.

Geognostic and Geographic Situations.

It is found in nests (nidular) in porphyry, near Tokay in Hungary, near Constantinople, and in the Kolyvanian mountains in Siberia.

Observations.

1. It is the link which connects jasper with opal, as is shewn, not only by its oryctognostic, but also by its geognostic characters.

2. It is distinguished from the five preceding subspecies by its greater liveliness of colour, stronger lustre, constant conchoidal fracture, easier frangibility, and inferior hardness.

Observation on the species Jasper.

The fossils of this species have generally deep colours, are opaque, or a little translucent on the edges; their

their fracture is generally conchoidal, and they are pretty hard, but rather in a low degree.

On the one side they are allied to indurated clay and lithomarge, on the other to hornstone, opal, chalcedony, and flint.

SECOND SPECIES.

Opal.

Opal.—*Werner*.

Werner divides this species into four sub-species, viz. 1. Precious opal, 2. Common opal, 3. Semi-opal, and 4. Wood opal.

FIRST SUBSPECIES.

Precious Opal.

Edler Opal.—*Werner*.

Id. Wid. p. 325.—Opal, *Kirw.* t. 1. p. 289.—Edler opal, *Emm. b.* 1. f. 341.—Opalo, *Nap.* p. 197.—Opale, *Lam.* t. 2. p. 154.—L'Opale noble, *Broch.* t. 1. p. 341.—Quartz-refinite opalin, *Haüy*, t. 2. p. 434.

External Characters.

Its colours are milk and yellowish white, but when held between the eye and the light they pass into pale rose red, and wine yellow.

It exhibits a most beautiful, and highly characteristic play of colours. The colours which it displays are verdegris green, emerald green, apple green, and fiskin green; also several varieties of blue, yellow, and red. Generally several of these colours occur together; sometimes, however, we meet with pieces which possess only one colour, and of these varieties, the green is the most beautiful and most highly valued.

Occurs massive, disseminated, in plates, and in strings or small veins.

Internally

Internally its lustre is commonly splendid, seldom passing into shining, and is vitreous.

Fracture pretty perfectly conchoidal.

Fragments indeterminately angular, sharp edged.

It is generally translucent, and sometimes approaches to faintly translucent, sometimes to semi-transparent, but seldom verges on transparent. The different degrees of transparency are accompanied by particular colours; thus the translucent passing into faintly translucent has generally a beautiful red and green play of colours, and is the most highly prized variety of opal: the varieties that are intermediate between translucent and semi-transparent are principally grey; and the semi-transparent passing into transparent exhibits a beautiful violet blue play of colours.

Semi-hard.

Brittle.

Uncommonly easily frangible,

Not particularly heavy, bordering on light.

Specific gravity—2,114, Blumenbach.

*light in weight
with one found*

Chemical Characters.

Before the blow pipe it becomes opaque, and milkwhite, but is infusible.

Constituent

Constituent Parts.

Silica	90	95
Water	10	
Alumina		5
	<hr/>	<hr/>
	100	100

Opal of Cscherwenitza, according to *Klaproth*, according to *Gerhard*.

Geognostic Situation.

It occurs diffeminated in clay porphyry, and according to Mr Da Camara, imbedded in reniform pieces in pearlstone porphyry.

Geographic Situation.

It is found at Cscherwenitza near Kaschau in Upper Hungary, and formerly in the neighbourhood of Freyberg in Saxony.

Use.

Although much prized on account of its beautiful play of colours, it is but ill suited for the purposes of jewellery, on account of its softness, great frangibility,

ty, and its sometimes splitting on a change of temperature. Jewellers generally set it with a foil, but many are of opinion that its beauty is greatest without any foreign aid. When a foil is used, it is either red, blue, or yellow, which latter is of gold; but it is said that a black foil has the most powerful effect in heightening its play of colours. It is principally used for ring stones and necklaces.

Observations.

1. The name opal is used by Pliny, but its derivation is unknown.

2. The finer varieties are named oriental opal; Tavernier, however, informs us that no precious opal is found in the East, and that those which are sold as oriental are brought from Hungary.

3. Some varieties which have by weathering lost a portion of their water of crystallization become opaque and dull, and acquire the property of adhering to the tongue, and of regaining nearly their original transparency on immersion in water. These are named Hydrophane, or, more properly, changeable opal. Great prices have been given for varieties of this kind.

4. In the imperial cabinet at Vienna there are two pieces of opal from the mines in Hungary, which deserve to be mentioned here. The one is about five inches long and two and a half in diameter, and ex-

hibits a very rich and splendid play of colours; the other, which is the size and shape of a hen's egg, is also extremely beautiful.

SECOND SUBSPECIES.

Common Opal.

Gemeiner Opal.—*Werner*.

Id. Wid. p. 325.—Semi opal, *Kirw.* vol. 1. p. 290.—Gemeiner opal, *Emm.* b. 1. f. 251.—Opalo, *Nap.* p. 197.—Girafol and Hydrophane, *Lam.* p. 156.—L'opal commune, *Broch*, t. 1. p. 344.—Quartz-refinite hydrophane et quartz-refinite girafol, *Hauy*, t. 2. p. 433. & 434.

External Characters.

Its principal colour is white, of which it exhibits the following varieties: greyish white, greenish white, yellowish white, and milk white. From greenish white it passes into apple green; from yellowish white into honey and wax yellow; and it very seldom occurs of a colour intermediate between flesh and tile red.

When

When the white varieties are held between the eye and the light they appear wine yellow.

It occurs massive, disseminated, and in sharp angular pieces.

Internally its lustre is generally splendent, sometimes passing into shining; and is vitreous, a little inclining to resinous.

Fracture perfectly conchoidal.

Fragments indeterminately angular and sharp edged.

Semi-transparent, approaching to translucent and transparent.

Semi-hard.

Brittle.

Very easily frangible.

Not particularly heavy, approaching to light.

Specific gravity—From 1,958 to 2,015, *Klaproth*.—
2,144, *Kirwan*.

Chemical Characters.

Before the blow pipe it is infusible without addition.

Constituent Parts.

	Opal of Kofemutz.	Of Telkobanya.
Silica	98,75	93,50
Alumina	0,1	
Oxyd of Iron	0,1	1,01
Water		3,0
	<hr/>	<hr/>
	98,95	99,50

According to *Klaproth*, t. 2. p. 164. & 169.

Geognostic Situation.

It occurs sometimes in veins, sometimes diffeminated, and principally in porphyry; but also in granite, gneifs, serpentine, and amygdaloid. In Iceland it alternates with chalcedony, with which it has been often confounded; and the green variety is found accompanying chrisopras, which lies in serpentine, at Kofemutz in Silefia.

Geographic Situation.

It is found in Iceland, the Faroe Islands, North of Ireland, in the electorate of Saxony, as at Freyberg, Hubertfberg, Eibenstock, Johanngeorgenstadt, and Schneeberg; in Bohemia, as at Bleistadt, Fribus, Heinrichfgrün;

Heinrichsgrün; Brittany in France; Silesia, Poland, at Florence in Italy, and Telkobanya in Hungary.

Use.

It is sometimes cut for ornamental purposes.

Observations.

1. Some varieties contain drops of water, and others are in the state of hyrophane, or changeable opal. If the changeable opal is immersed in melted wax, it absorbs a portion of it, and becomes transparent; but, on cooling, becomes again opaque. Opal thus impregnated with wax was named Pyrophane by Born.

2. Mullers glass, or Hyalite of Mr. Kirwan, which occurs in amygdaloid, probably belongs to this subspecies.

3. The girasol of Wallerius and Born appears to be milk-white translucent opal.

4. It has been considered by the French mineralogists as a variety of pitchstone, from which, however, it is most distinctly different. The colours of common opal are light, but those of pitchstone are deep; it is semi-hard, but pitchstone is hard; it has a specific gravity from 1,958 to 2,015, whereas pitchstone is 2,341; and it is more easily frangible and has more transparency than pitchstone.

THIRD SUBSPECIES.

Semi-opal.

Halb-opal.—*Werner*.

Id. Wid. f. 325.—Semi-opal, and several of the pitchstones of *Kirw.* vol. 1, p. 290, 292.—Halb-opal, *Emm.* b. 1. f. 256.
Id. Estner, b. 2. f. 429.—Semi-opalo, *Nap.* p. 201.—Pisfite, *Lam.* t. 2. p. 160.—La demi opal, *Broch.* t. 1. p. 347.—Quartz-refinite commune, and Q. R. Menilite, *Haüy.* t. 2. p. 433. & 335.

External Characters.

Its most common colours are white and grey. Of white it presents the following varieties: yellowish white, greenish white, and milk white; from yellowish white it passes into yellowish grey, greenish grey, and ash grey, and this latter into greyish black. From greenish grey it passes into leek green, apple green, and lastly into olive green; from yellowish grey it passes into honey yellow, wax yellow, and yellowish brown; and further into chestnut and hair brown.

Sometimes several colours occur together, and these are arranged in spotted and clouded delineations;

tions; but it is most commonly uniform or of one colour.

It occurs not only massive and disseminated, but also tuberosc, reniform, small botroidal, which approaches to the stalactitic, and in various extraneous external shapes*.

Externally it is glistening, internally generally glistening, sometimes approaching to shining, and passing into glimmering.

Fracture imperfectly large and flat conchoidal, which verges on even.

Fragments indeterminately angular sharp edged.

It is more or less translucent, and sometimes passes to translucent on the edges.

Semi-hard, approaching to hard.

Completely brittle.

Easily frangible.

Not particularly heavy approaching to light.

Specific gravity.—Brownish red from Telkobanya 2,540, according to *Klaproth*.

Chemical Characters.

Infusible before the blow pipe without addition; but with borax it melts, and without intumescence.

* Mr. Esmark affirms that he found supposititious crystals of semi-opal at Atzutza in Transylvania. *Bergm. Journal*.

CLAY GENUS.

Constituent Parts.

	Semi-opal of Telkobanya.	Menilite, or femi-opal of Menil Montant.
Silica	43,50	85,50
Alumina		1,00
Oxyd of iron	47,00	0,50
Lime		0,50
Water	7,50	
Water and carbonaceous matter		11,00
	98,0	98,50
		According to <i>Klaproth.</i>

Geognostic Situation.

It occurs in angular pieces and veins in porphyry and amygdaloid; also in metalliferous (most usually silver) veins that traverse granite and gneifs.

Geographic Situation.

It is found in Iceland, Faroe Islands, Scotland, in the Isle of Rume, where it occurs in amygdaloid, Electorate of Saxony, Bohemia, Frankfort on the Mayn, Silefia, Lower Austria, Poland, Hungary, Transylvania, Isle of Elba, and Siberia.

Observations.

Handwritten notes:
 Vitriol has been found in the
 the yellow part of the mineral
 from

Observations.

1. It is distinguished from common opal by the muddiness of its colours, its particular external shapes, lesser transparency, less perfect conchoidal fracture, and greater hardness and weight.

2. It borders on opal jasper, chalcedony, and conchoidal hornstone.

3. I observed in the possession of Sir Joseph Banks a tooth penetrated with opal. Estner also mentions bones petrified by semi-opal; and in Hoff's Mineralogical Magazine we have the following interesting notice:—"Hier ungefähr eine bis zwei stunden und noch etwas weiter nördlich von dem orte, wo sich die elephanten knochen im *aufgeschwemmten Lande* finden, bei den Dörfern Eckardleben Illeben, Niederthophstädt, Fromstadt, liegt meist deutlich über dem jüngere Gyps, eine oft 10 bis 12 lachter mächtige flötzschicht von einem merkwürdigen kalkstein mit kleinen quartz drusen, in welchem sich eine menge knochen, größtentheils wohl Fisch knochen, aber auch Saugethier, und vielleicht Land-thier-knochen fest eingewachsen befinden, welche zuweilen in opal verwandelt sind." *Hoff's Magazine, Erst. Band.* f. 457.

4. It has been arranged with pitchstone by Dolomieu, Fichtel, and other mineralogists.

5. The menilite, or variety of semi-opal from Menil Montant, is probably a distinct species, but nearly allied to opal.

FOURTH SUBSPECIES.

Wood Opal.

Holz Opal.—*Werner*.

Id *Wid.* p. 325.—Ligniform opal, *Kirw.* vol. 1. p. 295.
 Holz-opal, *Emm.* b. 1. f. 260.—Semi-opalo, *Nap.* p.
 201.—Xilopale, *Lam.* t. 2. p. 162.—Opal ligniforme,
Broch. t. 1. p. 350 —Variété du quartz-agathe xiloide,
Haüy.

External Characters.

It occurs most commonly greyish and yellowish white; sometimes also ochre yellow, and yellowish brown. From greyish white it passes into ash grey and greyish black.

It is sometimes uniform, sometimes marked with ring-shaped and striped delineations of different colours, which are conformable with the original texture of the wood.

It occurs in pieces which have the shape of branches, stems, &c.

Internally its lustre is glistening. *an unaltered skin*

Fracture more or less perfectly conchoidal, and shews its former ligneous texture.

Fragments indeterminately angular sharp edged.

It is translucent.

Between semi-hard and hard.

Easily frangible.

Not particularly heavy, bordering on light.

Specific gravity—2,600.

Geognostic and Geographic Situations.

Its geognostic situation is not known. It is found at Ponick near Schemnitz, and at Telkobanya in Hungary.

Observation.

It is wood penetrated with opal, and, according to Werner, is intermediate between common and semi-opal.

THIRD SPECIES.

Pitchstone.

Pechstein.—*Werner.*

Id. Wid. p. 332.—Pitchstone, *Kirw.* vol. 1. p. 292.—
 Pechstein *Efner*, b. 2. f. 435. *Id. Emm.* b. 1. f. 262.
 Pietra picea, *Nap.* p. 203.—Piffite var. h. *Lam.* t. 2.
 p. 162.—La Pierre de Poix, *Broch.* t. 1. p. 353.—*Petrofilex resiniforme*, *Haüy*, t. 4. p. 386.

External Characters.

Its colours are black, green, brown, red, and seldom grey. Of black it presents the following varieties: greenish, greyish, and brownish black. From greenish black it passes through blackish green into mountain green, asparagus green, leek green, olive green, and oil green. From olive green it passes into liver brown, yellowish and reddish brown, and further into light blood and brick red. The only varieties of grey are smoke and dark ash grey, and sometimes a kind of grey which passes into brown. It has sometimes a blueish colour.

Its

Its colours are not lively, but always somewhat deep and muddy, or rather mixed with grey and brown.

It is generally uniform, seldom several colours occur together.

It occurs almost always massive in great beds and rock masses.

Internally its lustre is shining, sometimes splendid, sometimes glistening, and intermediate between resinous and vitreous, yet more inclining to the first.

Fracture commonly imperfectly flat and large conchoidal, sometimes small conchoidal, and even passes into coarse splintery and coarse grained uneven.

Fragments indeterminately angular, more or less sharp edged.

It occurs sometimes in coarse, seldom in large and flat grained distinct concretions, and the surface of the concretions is somewhat bent; also in prismatic, generally wedge shaped distinct concretions. It is still seldomer found in thick and straight lamellar distinct concretions*. The surface of the concretions smooth.

It is commonly translucent in a small degree; the black variety is only translucent on the edges.

It is intermediate between hard and semi-hard.

Brittle.

Pretty easily frangible.

* Lamellar distinct concretions have been hitherto observed only in the pitchstone of the island of Arran.

Not particularly heavy.

Specific gravity—Saxon pitchstone, according to *Blumenbach*, 2,314.

Chemical Characters.

Before the blow pipe it is fusible without addition. The black variety, at 21° of Wedgwood's pyrometer, intumescd a little, its colour was slightly altered, the surface glazed, and internally porous; at 31° , intumescd considerably and softened; at 65° , the intumescence was more considerable; at 100° , it was still vesicular but more compact. The blackish green variety of Arran becomes black, is much rent, and internally porous at 23° ; at 55° formed a porous enamel; at 70° it became perfectly white, and still porous*.

* Mineralogy of the Scottish isles, vol. 1.

Constituent Parts.

Pitchstone of Meiffen.

Silica	73,0	64,58
Alumina	14,50	15,41
Lime	1,0	
Oxyd of iron	1,0	5,0
Oxyd of manganese	0,10	
Natron	1,75	
Water	8,50	
Lofs		15,0
	<hr/>	<hr/>
	99,85	99,99

*Klaproth. Beiträge, b. 3. f. 261.**Wiegleb.**Geognostic Situation.*

It occurs in beds in the newer porphyry formation, and in beds and veins that belong to the newest flötz trap formation*.

Geographic Situation.

That belonging to the newer porphyry formation is found in great quantity in the Electorate of Saxony,

* Mineralogy of the Scottish isles.

particularly

particularly in the neighbourhood of Meissen; also in Hungary, as at Tokay and Schemnitz; in the islands of the Archipelago, where it was first observed by Mr Hawkins; and at Glamoscarg in the Island of Skye*.

The varieties belonging to the newest floetz trap formation are found in great abundance in the Island of Arran, also in the Islands of Mull and Canna†, and near Ekdale Muir, in the mountainous part of Dumfriesshire‡.

Probably the pitchstone of Zwickau in Upper Saxony belongs to the floetz trap formation.

Observations.

1. It was first discovered about fifty years ago in the neighbourhood of Meissen in the Electorate of Saxony.

2. It is named Pitchstone from the striking resemblance which several of its varieties bear to pitch.

3. Many of the French mineralogists have arranged it with opal, and Abbé Hauy, with equal impropriety, considers it but as a variety of petrosilex.

* Mineralogy of the Scottish isles.

† *Id.*

‡ Geognostical Sketch of Dumfriesshire.

FOURTH SPECIES.

Obsidian.

Obsidian.—*Werner.*

Wid. p. 348. *Kirw.* v. 1. p. 265.—Obsidiana, *Nap.* p. 205.—Lava vitreuse, Obsidienne, *Haüy*, t. 4. p. 494.—L'Obsidienne, *Broch.* t. 1. p. 288.—Iceland agate of many mineralogists.

External Characters.

Its principal colour is velvet black; it occurs also greyish black, brownish black, and greenish black; also dark ash grey and smoke grey. Some varieties pass into light hair brown, and clove brown*. Other varieties, particularly the ash grey, are spotted and striped. The black variety when held between the

* The hair and clove brown varieties are found imbedded in roundish pieces in pearlstone, at the mouth of the river Marechanka, on the sea of Ochotsk. Karsten considers them as specifically distinct from Obsidian, and places them in his system under the name Marekan.

eye and the light appears always greenish on the edges.

It always occurs in angular more or less blunt-edged roundish pieces, which have a rough surface. In pearlstone it occurs in roundish grains.

Internally it is usually splendent, sometimes passing to shining, and is vitreous.

Fracture more or less perfectly large conchoidal.

Fragments indeterminately angular sharp edged*.

The dark varieties are translucent only on the edges; but the lighter are translucent, and some rare varieties (particularly the clove brown variety) are almost semi-transparent, bordering on transparent.

Hard.

Easily frangible.

Not particularly heavy.

Specific gravity—2,348.

Chemical Character.

According to Lampadius, when exposed to a strong heat in an air furnace, it loses its colour, and is changed into a porous slag. By exposure to a white heat for two hours the cellular mass is not melted into glass.

* The Hungarian obsidian appears to occur in large roundish distinct concretions.

Constituent Parts.

Silica	69,0	74,0
Alumina	22,0	12,0
Oxyd of iron	9,0	14,0
	<hr/>	<hr/>
	100	90,0
<i>Bergman.</i>		<i>Abilgaard.</i>

Geognostic Situation.

It is found nidular in pearlstone in the newer porphyry formation in Hungary, and it is probable that it occurs in a similar repository in other parts of the world. It has sometimes grains and crystals of felspar and quartz imbedded, hence it is porphyritic.

Geographic Situation.

It is found in Iceland; in Hungary, at Tokay; in Siberia, at Ochotz, and on the banks of the river Mareskanka; in the Islands of the Archipelago, particularly in the Island of Melos, where it was first discovered by Mr Hawkins; also in immense beds in the Lipari Islands; in Peru, Island of Madagalcar, and several of the South Sea islands.

M m 2 Use.

Use.

When cut and polished it is sometimes used for ornamental purposes, and telescopic mirrors have been made of it.

Observations.

1. It has been much disputed whether or not it is a product of fire. The discovery of Esmark the Norwegian, who found it alternating with porphyry, demonstrates that in some instances it is of aquatic formation; it is even highly probable that the great rocks of obsidian and pumice which are found in the Lipari Islands have had a similar origin.

2. It sometimes passes into pumice.

FIFTH SPECIES.

Pearlstone.

Perlitein — Werner.

External Characters.

It is generally grey, sometimes also black and red. The varieties of grey are smoke, bluish, ash, yellowish and pearl grey; from dark ash grey it passes into greyish black: from pearl grey into flesh and brick red, and reddish brown.

It occurs vesicular, and the vesicles are round and longish.

Its lustre is shining and pearly.

Its fracture, on account of the thinness of the distinct concretions, is hardly observable, but appears to be small and imperfectly conchoidal.

Fragments are in the large indeterminately angular and blunt edged.

It occurs in large, coarse, and angularly grained distinct concretions, that include small and round grained concretions, which are again composed of very thin concentric lamellar concretions. The surface of the concretions, particularly in the small, is smooth,

smooth, shining, and pearly, and has a striking resemblance to that of pearl.

It is translucent on the edges.

Not very brittle.

Uncommonly easily frangible.

Soft, passing into very soft.

Not particularly heavy, approaching to light.

Constituent Parts.

Pearlstone of Hungary.

Silica	75,25
Alumina	12,0
Oxyd of iron	1,60
Potash	4,50
Lime	4,50
Water	4,50

98,35

According to *Klaproth*.

Geognostic Situation.

It is found in beds in porphyry, and often contains balls of obsidian.

Geographic Situation.

It is found in the neighbourhood of Tokay in Hungary, near Ochotsk in Kamschatska, and near Sandy Brae in the north of Ireland. Some of its transitions to other fossils occur in the interesting Island of Egg, one of the Hebrides, and near Sandy Brae in Ireland. Does the pearlstone of Sandy Brae belong to the floetz trap formation? *Small pieces of it may change form.*

Observation.

The vesicular variety, particularly the longish, often bears a striking resemblance to pumice; indeed it appears to pass into it.

SIXTH SPECIES.

Pumice.

Bimstein.—*Werner*.*External Characters.*

Its colour is light yellowish grey, and smoke grey; sometimes verging on dark greyish white, and light ash grey.

It is small and lengthened vesicular.

The lustre of its principal fracture is glistening, passing to shining, and is pearly; the cross fracture is shining and vitreous.

Its principal fracture is parallelly curved fibrous; the cross fracture uneven and imperfectly conchoidal.

Fragments indeterminately angular, blunt edged and splintery.

Generally translucent on the edges.

Soft and very soft, sometimes approaching to semi-hard.

Completely brittle.

Pretty easily frangible.

Is swimming.

Chemical Characters.

It melts before the blow pipe into a whitish coloured glass.

Constituent Parts.

Silica	90,0	77,50
Alumina		17,50
Magnesia	10,0	
Oxyd of Iron		1,75
		<hr/>
	100,0	96,75
	<i>Bergmann.</i>	<i>Klaproth.</i>

Dr. Kennedy, besides the ingredients mentioned by Klaproth and Bergman, found a portion of potash.

Geognostic Situation.

According to Esmark it is found in Hungary along with pearlstone, which alternates with porphyry. In the Lipari Islands it is accompanied with obsidian, into which it passes; and on the banks of the Rhine, between Andernach and Coblentz, it is found in great quantity, accompanied by rocks, that probably belong to the floetz trap formation.

N n

Although

Although it has been usually classed among the volcanic products, on account of its supposed igneous origin, we must confess that in Hungary at least it is demonstrably of aquatic formation ; and we may on pretty sure grounds consider that of Lipari and Andernach as a portion of one of those great and universal formations which have been deposited from a state of solution in water. In the Geognosie will be given a full statement of the interesting facts which render this opinion probable.

Geographic Situation.

It is found in the Lipari Islands, Hungary, banks of the Rhine between Andernach and Coblenz, Iceland ? and it has been observed particularly beautiful in the Island of Santorine in the Helespontic Archipelago.

Uses.

It is used for polishing stones, metals, glass and ivory ; also for preparing parchment.

SEVENTH SPECIES.

Felspar*.

Feldspath.—*Werner*.

This species is divided by Werner into four sub-species, 1. Compact felspar, 2. Common felspar, 3. Adularia, 4. Labradore stone.

* More properly Feldspar,

FIRST SUBSPECIES.

Compact Felspar.

Dichter Feldspath.—*Werner*.

Id. Wid. p. 345.—Continuous felspar, *Kirw.* vol. 1. p. 323.—Felsite, *Id.* p. 326.—Dichter feldstein, *Esfner*, b. 2. f. 511. *Id. Emm.* b. 1. f. 271.—Felspatto compatto, *Nap.* p. 218.—Feldspath compacte bleu, *Hauy*, t. 2. p. 615.—Le feldspath compacte, *Broch.* t. 1. p. 367.

External Characters.

Its colours are grey, white, blue, green, and red. The varieties of white are greenish and greyish white: Of grey, greenish, smoke and ash grey; from greenish grey it passes into apple green, pistacio green, even into mountain green; further into sky blue and smalt blue; it occurs also flesh red and blood red.

Occurs massive, disseminated, in rolled pieces, and in crystals, which are imbedded in antique green porphyry.

Internally its lustre is sometimes glistening, some times glimmering.

Fracture

Fracture at first sight appears to be only splintery, but when carefully examined we find it also to be very fine grained, or imperfectly and very small foliated.

Fragments indeterminately angular, and not particularly sharp edged.

It sometimes presents fine grained distinct concretions.

Translucent, but sometimes only on the edges.

Pretty hard, but in a low degree.

Easily frangible.

Not particularly heavy.

60 Silica
9 Alumina
1 Lime

Chemical Character.

5 1/2 Potash
14 Op of lime
24 Water

It is fusible without addition before the blow pipe.

Geognostic Situation.

It is one of the constituent parts of primitive, transition, and floetz greenstone, also of greenstone slate, and is imbedded in crystals in antique porphyry.

found in the basis of felspar porphyry

Geographic Situation.

It is found in Saxony, the Tyrol, Carinthia; in Scotland, at the Pentland hills, and Salisbury craigs

where it is associated with the clay near

near Edinburgh; Coriarich in Invernessshire, and many other places.

Observations.

On account of its splintery fracture, and slight degree of lustre, it used to be considered as a variety of hornstone; even the late intelligent Mr Dolomieu continued to name it petrosilex. Werner considers it as a subspecies of felspar, because 1. It occurs most generally along with quartz and mica, thus assuming as it were the place of common felspar. 2. It has combined with the splintery a foliated fracture. 3. It passes into common felspar. 4. It occurs crystallized in antique green porphyry. 5. It melts without addition before the blow pipe.

SECOND SUBSPECIES.

Common Felspar.

Gemeiner Feldspath.—*Werner.*

Werner divides it into two kinds: *a.* Fresh felspar, *b.* Disintegrated felspar.

FIRST

FIRST KIND.

Fresh felspar.

Frischer feldspath.—*Werner*.

Spathum scintillans, *Wall.* t. 1. p. 214.—Feldspath, *Wid.* p. 335. *Ibid.* *R. d. L.* t. 2. p. 445.—Common felspar, *Kirw.* vol. 1. p. 316.—Blättrig Feldstein, *Efner*, b. 1. f. 513.—Gemeiner feldspath, *Emm.* b. 1. f. 266.—Feldspato commune, *Nap.* p. 213.—Feldspath, *Lam.* t. 2. p. 187. *Ibid.* *Hauy*, t. 2. p. 590.—Le Feldspath commun. *Broch.* t. 1. p. 362.

External Characters.

Its colours are white, red, grey, and green. Of white it presents the following varieties; greyish, milk, yellowish, greenish, and reddish white: the greyish white rarely passes into smoke grey and blueish grey. Of red the following varieties occur, flesh, blood, and sometimes verges on brick red. From greenish white it passes into asparagus green, leek green, mountain green, even into verdegis green, but this latter is a rare variety.

The

The greenish white variety borders on adularia, and the edges have a reddish shade.

It occurs most commonly massive, disseminated, in angular pieces, in rolled pieces, and grains; also frequently crystallized. The following are its principal figures.

1. Broad six-sided prism, nearly equally bevelled on both extremities, and the bevilling planes set on those lateral edges which are formed by the smaller lateral planes. Sometimes the acute lateral edges are truncated, sometimes also bevelled; the obtuse edges are also in some instances truncated.
2. Very oblique four-sided prism, flatly bevelled on the extremities, and the bevilling planes set on the obtuse lateral edges. When the prism becomes short, and two obliquely opposite bevilling planes increase so much as to cause the others to disappear, a rhomboid is formed.
3. Rectangular four-sided prism, acuminate by four planes which are set on the lateral edges; the summit of the acuminations and lateral edges of the prism are sometimes truncated.

The crystals occur sometimes in twin crystals, and sometimes scalar-wise aggregated.

The twin crystals are formed in different ways; one variety is conceived to be formed by two crystals being

being side-wise pushed into each other; and in another, or what has been called hemitrope, the crystal is supposed to be divided into two, and one half turned completely around and applied to the other, so that a re-entering angle is formed at the one extremity, and a salient angle at the other.

The crystals are small and middle sized, (particularly the four and six sided prisms) often all around crystallised in druses.

Externally its lustre is shining; internally the principal fracture is shining approaching to splendid, cross fracture is glimmering, and both are vitreous, inclining a little to pearly.

Fracture more or less perfectly straight foliated, two-fold cleavage, and the folia cross each other at right angles. Cross fracture fine grained uneven, passing into splintery; parallel with this fracture we observe rents that cut the other cleavages obliquely, so that the fragments are somewhat rhomboidal. Sometimes the foliated is a little curved foliated, and is seldom uniformly foliated, which passes into a kind of diverging broad radiated.

Occurs in large, coarse, and small grained distinct concretions

More or less translucent.

Pretty hard*.

Brittle.

Easily frangible.

* Scratches glass.—*Hazy.*

Not particularly heavy.

Specific gravity—From 2,272 to 2,594.—According to *Haüy*, from 2,4378 to 2,7045.

For the geognostic and geographic characters see the end of the following description.

Chemical Characters.

It melts without addition before the blowpipe into a white glass.

Constituent Parts.

Silica	62,83	64,0	67,0	43,0	79,0	70
Alumina	17,02	21,0	14,0	37,05	16,0	12
Lime	3,00	6,25		1,70	2,3	
Oxyd of Iron	1,00	2,0		4,0		
Potash	13,00					
Baryt			11,0			8
Magnesia			8,0			9
Lofs		3,75				
	<hr/>	<hr/>	<hr/>	<hr/>	<hr/>	<hr/>
	96,85		100	85,72	97,3	99
	<i>Vauquelin</i> *	<i>Chenevix</i>	<i>Kirwan</i>	<i>Saussure</i>	<i>Meyer</i>	<i>Haffenf.</i>

* *Vauquelin's* experiments were made on the green coloured Siberian felspar.

SECOND KIND.

Disintegrated felspar.

Aufgelöster feldspath.—*Werner.*

Its colour is yellowish and reddish white, which sometimes verges on grey.

Occurs massive, disseminated, and in imbedded crystals, resembling in figure those of fresh felspar.

Internally its lustre alternates between glistening, glimmering, and dull.

Fracture in some varieties is imperfectly foliated, passing into earthy; in others it is intermediate between uneven, which approaches to splintery, and earthy.

Fragments indeterminately angular, blunt edged.

It has a tendency to distinct concretions, but this only when it is passing to fresh.

Only a little translucent on the edges, generally opaque.

Soft, passing into very soft: also semi-hard

Easily frangible.

Not particularly heavy.

Observations.

1. The disintegrated condition of this kind of felspar is owing in many instances to weathering ; but it is also highly probable that it is often originally formed in a similar state.
2. It is the link which connects felspar with porcelain clay.
3. We observe a diminishing fusibility from common felspar through disintegrated felspar to porcelain clay, which depends, according to Werner, on the relative proportion of alkali in each.

Geognostic Situation of common felspar.

It is one of the most abundant of fossils. It forms a constituent part of granite and gneiss ; it occurs also in sienite, in greenstone, and in imbedded crystals in porphyry, basalt, and porphyry slate. It also occurs in beds and kidneys in primitive mountains, and in veins of the oldest formation.

Geographic Situation of common felspar.

It is so universally distributed that we shall only mention the localities of a few of the most remarkable varieties. The beautiful green coloured variety is
found

found in Siberia; the twin crystals are found very fine at Baveno, and near to Carlsbad in Bohemia; the floriformly foliated in Saxony and the island of Arran; the curved foliated in Sweden, and it is found in uncommonly large distinct concretions in the island of Rona, one of the Hebrides.

THIRD SUBSPECIES.

Adularia.

Adular.—*Werner.*

Moonstone, *Kirw.* vol. 1. p. 322.—Adular. *Estner*: b. 1. f. 525.—*Id. Emm.* b. 1. f. 277.—Adularia, *Nap.* p. 218.—Adulaire, *Lam.* t. 2. p. 194. — *Id. Broch.* t. 1. p. 371 —Feldspath nacre, *Haüy*, t. 2. p. 606.

External Characters.

Its most common colour is greenish white, which often inclines strongly to asparagus green. Sometimes it contains milk white spots that possess a silvery lustre and pearly shine.

It is found massive, in rolled pieces, and crystallized in

1. Oblique four-sided prisms, obtusely bevelled on both ends.
2. Six-sided prisms.
3. Rectangular four-sided prisms, with oblique terminal faces.

The

The crystals are longitudinally streaked, middle sized, large, and very large.

Lustre of the surface is mostly splendid, approaching to pearly.

Lustre of the principal fracture is splendid; the cross fracture shining, and intermediate between vitreous and pearly.

The principal fracture is perfectly specularly foliated, with a two-fold rectangularly intersecting cleavage; cross fracture small and imperfectly conchoidal.

Fragments rhomboidal.

Has a tendency to thick and straight lamellar distinct concretions.

Semitransparent and translucent.

Hard.

Brittle.

Easily frangible.

Not particularly heavy.

Specific gravity.—From 2,500 to 2,600, *Struve*.—2,561. *Morell*.

Chemical Characters.

Before the blow pipe melts without addition into a whitish glass.

Constituent

CLAY GENUS.

Constituent Parts.

Silica	64,0	62,50	62,43	64
Alumina	20,0	17,50	19,33	24
Lime	2,0	6,50		6,25
Sulphat of lime			10,98	
Potash	14,0			
Magnesia		6,0	5,50	
Oxyd of iron		1,40		2,00
Sulphat of barytes		2,00		
Water		0,25	1,75	1,75
Loss				3,75
	————	————	————	————
	100,0	96,15	99,99	100
	<i>Vauquelin.</i>	<i>Vestrumb*.</i>	<i>Morell †.</i>	<i>Genevix.</i>

Geognostic Situation.

It is found in veins and cavities in gneifs and mica slate, and is accompanied with quartz, mica, common felspar, and tourmaline.

* Chem. Ann. 1790. b. 2. p. 225.

† Hæpfner. Mag. Helv. t. 2. p. 95.

Geographic Situation.

It is found in the mountain of St Gothard in Switzerland, and particularly in the summit named Adula, whence its name has been derived; also in the island of Arran*. The variety called moonstone is principally found in the island of Ceylon.

Observations..

1. The water opal, and girasol of the Italians, and also the sunstone†, are varieties of adularia, and nearly the same with moonstone.

2. Adularia is distinguished from common felspar by its greenish white colour, particular colour reflection, complete conchoidal cross fracture, lamellar distinct concretions, its higher degree of transparency, and by the want of those rents which cross the cleavage obliquely in common felspar.

Werner suspects that moonstone may be considered as adularia, because it differs from it by its milk white colour, which is flesh red when held between the eye and the light, and its silvery lustre.

* Mineralogy of the Scottish Isles.

† The fossil called sunstone has a hyacinth and blood red colour, and a beautiful silvery or pearly reflection: Werner suspects that it is moonstone artificially coloured.

FOURTH SUBSPECIES.

Labrador Stone.

Labradorstein.—*Werner*,

Pierre de Labrador, *R. d. L.* t. 2. p. 497.—Variety of common felspar, *Wid.* p. 335.—Labrador stone, *Kirw.* vol. 1. p. 324.—Labradorstein, *Emm.* b. 1. f. 273.—Variety of feldspatho commune, *Nap.* p. 213.—Labradorite, *Lam.* t. 2. p. 197.—Feldspath opalin, *Hauy.* t. 2. p. 607 —La pierre de labrador, *Broch.* t. 1. p. 369.

External Characters.

Its principal colour is smoke grey, which passes into dark ash and yellowish grey. It exhibits, when held in a determinate position, a great variety of colours, as blue, green, yellow, red, and brown. Of blue it presents the following varieties, violet, azure, Berlin, sky, and smalt blue; from the latter it passes through verdegriis into emerald, grass, pistacio, olive, and fisikin green; from this it passes into sulphur, lemon and orange yellow, which latter passes into
copper

copper red; and feldom pearl grey. In short this fossil exhibits all the varieties of green and blue.

The red and yellow colours are the rarest.

It exhibits spotted and striped delineations. Sometimes the same spot if held in different directions changes its colour, for instance, from sky blue to verdgris green, and this into grass green. These beautiful colours feldom extend over a whole piece, in general they shew themselves only in larger and smaller spots or patches.

Different colours are presented according as we hold the piece between the light and the eye, or the eye and the light.

Occurs commonly massive, in blunt edged pieces and rolled pieces.

Its principal fracture is shining, passing into splendid; the cross fracture glistening, and is intermediate between pearly and vitreous.

Fracture perfectly foliated, and the folia cross each other at right angles.

It occurs usually in large, coarse, and feldom in small grained distinct concretions; feldomer in thick and straight lamellar distinct concretions.

Strongly translucent.

Not particularly heavy.

In other characters resembles the preceding.

Specific gravity—2,607 to 2,704, *Briffon*.

Chemical Characters.

It is fusible into a white enamel without addition before the blow pipe.

Constituent Parts.

Silica	69,5
Alumina	13,6
Sulphat of lime	12,0
Oxyd of copper	0,7
— of iron	0,3

According to Bindheim.

Geognostic Situation.

It forms one of the constituent parts of certain kinds of greenstone, occurs also in syenite, and is accompanied with mica, horn, and seldom with iron pyrites.

Geographic Situation.

It was first discovered in the island of St Paul, on the coast of Labrador, where it is still found in considerable

siderable quantity. It has been also found in Ingermannland between Denmark and Norway, and near to the romantic lake Baikal in Siberia.

Uses.

On account of its beautiful colours it is cut for ornamental purposes.

Observations.

1. Werner supposes that the changeability of colour by which this subspecies is characterised is not original, because it is only observable on or near the surfaces, never towards the centre of the masses. It may be owing to the infiltration of sea-water*.

2. It is principally distinguished from common felspar by its colour, which is either smoke or dark grey, its peculiar changeability of colours, and straight lamellar distinct concretions.

3. It was first discovered by the Moravians, who have a colony on the coast of Labrador, about thirty years ago.

* Glass by exposure to the weather, we know, is so changed as to reflect a variety of colours.

NINTH SPECIES.

Pure Clay.

Reine Thonerde.—*Werner*.

Id. Wern. Cronst. p. 176,—*Id. Wid.* p. 385.—Native Argil, *Kirw.* t. 1. p. 175 —*Argilla pura, Nap.* p. 246.—*L'alumine pure, Broch.* t. 1. p. 318

External Characters.

It is snow white, which sometimes verges on yellowish white.

Occurs in small kidney shaped pieces.

It has no lustre.

Fracture very fine earthy.

Fragments indeterminately angular, and very blunt edged.

Opaque.

Soils very little.

Adheres slightly to the tongue.

Intermediate between very soft and friable.

Light.

Feels fine but meagre.

Constituent

Constituent Parts.

Alumina	45
Sulphat of lime	24
Water	27
Lime, filica and a muriat	4

 100

According to *Fourcroy*. *Annales de Mus. N. A. t. I.*
p. 48.

According to Schreber and Frischman it contains alumina, mixed with a very little carbonate of lime and filica. Scherer has also analysed it, but I am not acquainted with the result of his experiments.

Geognostic Situation.

It is found immediately under the foil, accompanied with foliated gypsum and felenite.

Geographic Situation.

Has been found only at Halle in Saxony.

Observation.

Observation.

Widenmann, from the kind of its repository, and its vicinity to a great laboratory, suspects it to be artificial, and the refuse of some chemical operation. Its external shape, however, is a sufficient proof of its being a natural production ; and, I may add, that no laboratory is nearer the spot where it is found than a quarter of a league.

TENTH SPECIES.

Porcelain Earth.

Porzellanerde.—*Werner.*

Porcelain clay, *Kirw.* vol. 1, p. 178.—*Argilla da porcellana, Nap.* p. 248.—*Feldspath argilliforme, Haüy, t. 2.* p. 616.—*La terre a porcelaine, Broch t. 1, p. 320.*

External Characters.

Its colour is generally reddish white, of various degrees of intensity, which sometimes inclines to yellowish and greyish white.

Occurs massive and disseminated.

Its particles are fine dusty.

Colours strongly.

It is slightly cohering.

Feels fine, but pretty meagre.

Scarcely adheres to the tongue.

Light.

It is of great importance to remember the colour of this mineral.

CLAY GENUS.

Constituent Parts.

		Earth of Limoges.	
Silica	52	55	62
Alumina	47	27	19
Iron	0,33	0,5	
Water		14	
Lime		2,0	
Magnesia			12
Sulphat' of barytes			7,0
	<i>Rose.</i>	<i>Vauquelin.</i>	<i>Hassenfratz.</i>

Chemical Character.

It is nearly infusible in the greatest heat of a porcelain furnace.

Geognostic Situation.

Sometimes, as at Aue, near Schneeberg in Saxony, porcelain earth occurs in beds in gneiss, and is accompanied with quartz, and sometimes with iron stone. Sometimes it takes the place of felspar in forming one of the constituent parts of granite; we even find large crystals of felspar filled with it. At great depths in the mines of the Freyberg mining field, I have observed beds of gneiss, completely sheltered

sheltered from every influence of the weather, in which the felspar was in the state of porcelain earth.

These facts render it probable, that porcelain earth is analogous to felspar, and that it is a nearly similar substance, which has been deposited in a looser state of aggregation. All porcelain earth, however, has not been formed in this manner; for it is often the result of the decomposition of felspar, contained in granite or gneiss.

It is still uncertain whether or not it may not be formed from the decomposed matter of other rocks.

Geographic Situation.

The finest porcelain earth of Saxony, with which the famous porcelain manufactory at Meissen is carried on, is brought from Aue. That used for manufacturing the fine Berlin porcelain is dug at Gömritz, below Halle, in the district of Magdeburg; also at Zotenberg and Giern in Lower Silesia. The Austrian porcelain is made from a fine earth which is dug at Passau; the French porcelain is manufactured with clay dug near Limoges; and the English is principally manufactured from the porcelain earth of Cornwall.

In China and Japan, where it is called Kaolin, it appears to occur in great quantity, and is used for the same purposes as the European.

In Scotland it occurs in small quantity in the county of Galloway, and in the Mainland, one of the Shetland islands.

Use.

It used alone, or intermixed with other earths, or felspar for the manufacture of porcelain.

ELEVENTH SPECIES:

[Common Clay.

Gemeinerthon,—*Werner*.

Werner divides this species into six subspecies, *viz.*

1. Loam.
2. Potters clay.
3. Pipe clay.
4. Variegated clay.
5. Clay stone.
6. Slate clay.

FIRST SUBSPECIES.

Loam.

Leim.—*Werner*.

External Characters.

Its colour is yellowish grey, and is frequently spotted yellow and brown.

Occurs massive, and in great masses.

It is dull, and sometimes weakly glimmering, but this only when small scales of mica are present.

Fracture is in the great uneven, in the small fine earthy.

Fragments are indeterminately angular, very blunt edged.

Colours a little.

Intermediate between loose and cohering, but more inclining to the first.

Adheres pretty strongly to the tongue.

Feels slightly greasy. 100.05.10

Not particularly heavy, approaching to light.

Observation.

Observation.

It is very impure, being mixed with sand and gravel, and also iron ochre. It may be considered as sandy potter's clay, mixed with mica and iron ochre.

SECOND SUBSPECIES.

Potters Clay.

Töpferthon.—*Werner.*

This subspecies is by Werner divided into two kinds, the *a.* Earthy, and *b.* Slaty.

a. Earthy

FIRST KIND.

Earthy potters Clay.

External Characters.

It colours are yellowish and greyish white; also greenish, blueish and smoke grey, and these colours are of various degrees of intensity. The greenish grey sometimes passes into mountain green, but this is rare.

Occurs massive, and in considerable masses.

Fracture in the small pretty fine earthy, in the great coarse grained uneven.

Fragments indeterminately angular, blunt edged.

Opaque.

Colours a little.

Very soft passing to loose.

Adheres strongly to the tongue-

Feels a little greasy.

Not particularly heavy, approaching to light.

SECOND

SECOND KIND.

Slaty potters Clay. †

External Characters.

Its colour is dark ash grey, but it sometimes also falls into brown.

Its principal fracture is imperfectly conchoidal, the cross fracture earthy.

Fragments indeterminately angular and tabular.

Light, verging on not particularly heavy.

Feels more greasy than the preceding.

In other characters it agrees with the earthy.

Geognostic Situation.

It occurs in great rock masses, and in beds in alluvial land. Many of the mineral veins in primitive mountains are lined with it.

Geographic Situation.

It is very universally distributed.

Use.

As it forms a paste with water, and can be baked without cracking, it is used in potteries, for the manufacture of the common kinds of earthen ware. It is also made into bricks and tiles, and is used in founderies for lining crucibles to preserve them from fusion; in smelting houses, to assist the fusion of calcareous ores; and by the agriculturist for the improving of sandy soils.

Observation.

It is composed of the finest part of the detritus of decomposing rocks, as of granite, gneiss, porphyry, &c. which is washed down by great rains and floods, and afterwards deposited in still places.

THIRD SUBSPECIES.

Pipe Clay.

Pfeifenthon.—*Werner*.

External Characters.

Its colour is greyish white passing into yellowish white, and both fall strongly into grey.

Occurs massive.

Lustre glimmering.

Fracture in the small, fine earthy; in the large, coarse and fine grained uneven.

Fragments indeterminately angular, sharp-edged.

Streak shining.

Intermediate between loose and coherent, but more generally coherent.

Adheres pretty strongly to the tongue.

Feels rather greasy.

Easily frangible.

Light, passing into not particularly heavy.

FOURTH SUBSPECIES.

Variegated Clay.

Bunterthon.—*Werner.**External Characters.*

White, red, and yellow are its chief colours. Of white, the only variety is yellowish white, which passes into ochre yellow, and sometimes into yellowish brown. The varieties of red are, reddish white, which passes into pearl grey, flesh red, and peach blossom red.

It is marked with striped, veined, and spotted delineations.

Occurs massive.

Fracture earthy, and then it has no lustre; sometimes has a tendency to flaty, then it is glimmering.

Its streak is shining.

Very soft, passing into friable.

Feels a little greasy.

Adheres a little to the tongue.

Mild.

Light, passing into not particularly heavy.

Geographic

Geographic Situation.

It is found at Wehraw in Upper Lufatia.

Observations.

1. It does not form so kneadable a mass as the preceding.
2. It is the link which connects clay with lithomarge, and stands between it and pipe clay.

FIFTH SUBSPECIES.

Claystone.

Thonstein.—*Werner*.*External Characters.*

Its most common colours are grey and red. Of grey it presents the following varieties: greenish, bluish, ash, smoke, and pearl grey; from pearl grey it passes into brownish red. It is sometimes marked by yellowish brown spotted and striped delineations.

It occurs massive.

It is dull.

Fracture generally fine earthy, which sometimes passes into fine grained even, sometimes into flaty, and even splintery; some varieties are flat conchoidal, with a tendency to flaty.

Fragments indeterminately angular, seldom tabular, and not particularly sharp edged.

It is opaque.

Soft, approaching to very soft.

Not particularly brittle.

Pretty easily frangible.

Does not adhere to the tongue.

Feels rather meagre.

Geognostic Situation.

It forms vast rock masses, occurs in beds, in veins, and makes the basis of clay porphyry. It is found accompanying the newest porphyry formation, also in beds and veins in the independent coal formation.

Geographic Situation.

It is found in Saxony, as at Chemnitz, Stolberg, and the Windberg in the Plauischen Grunde near to Dresden; also in Scotland, as in the Pentland Hills near Edinburgh, and the Island of Papa Stour, one of the Shetlands.

Observations.

It passes sometimes into potters clay, sometimes into slate clay, and also into jasper. It probably also passes into compact felspar; the reasons for this supposition will be fully explained in the Geognosie, where I shall have an opportunity of detailing several new and interesting facts respecting this fossil, considered as constituting a particular formation.

SIXTH SUBSPECIES.

Slate Clay.

Schieferthon.—*Werner*.

Slate clay, shale, *Kirw.* t. i. p. 182.—L'Argile schisteuse,
Broch. t. i. p. 327.

External Characters.

Its colour is grey, of which it presents the following varieties; smoke grey, yellowish grey, and ash grey, which latter sometimes approaches to blueish grey. From ash grey it passes into greyish black.

It is massive.

Internally it is dull, but when it contains intermixed mica it is glimmering.

Fracture more or less perfectly flat, sometimes approaching to earthy.

Fragments indeterminately angular and tabular.

It is opaque.

Intermediate between soft and very soft.

Mild.

Easily frangible.

Not

Adheres a little to the tongue.

Feels meagre.

Not particularly heavy, approaching to light.

Specific gravity.—According to *Kirwan*, from 2,600 to 2,680.

Geognostic Situation.

It occurs in beds and strata? It is an almost constant attendant of coal; and it is found also in the newest floetz trap and alluvial formations.

Geographic Situations.

It is found generally wherever the coal, floetz trap, and alluvial formations occur, so that its distribution is universal.

Observations.

1. According to its external characters it stands between potters clay and clay stone, and sometimes (particularly the dark variety) passes into bituminous shale.

2. It is sufficiently distinguished from clay slate by its colour, inferior hardness and weight; its adhesion

to the tongue, and its becoming soft, and breaking in water.

3. It very often contains carbonised and bituminated vegetable impressions, which generally belong to ferns and reeds.

TWELFTH SPECIES.

Polier, or Polishing Slate.

Polierschiefer.—*Werner*.

External Characters.

Its colour is yellowish grey, which approaches to cream yellow and yellowish white.

It is always striped, and the colours alternate in layers.

Occurs only massive.

Internally it is dull.

Its principal fracture is slaty, the cross fracture earthy.

Fragments generally tabular.

Very soft passing into soft.

Adheres to the tongue.

Feels fine but meagre.

Not particularly heavy, approaching to light, even nearly swimming. It is lighter than tripoli.

Geognostic Situation.

It is found in the vicinity of pseudo volcanos, and is supposed by Werner to be the ashes of coal, which have been washed down into the lower grounds, and deposited in a regular form. This opinion will be illustrated and explained in the geognostic.

Geographic Situation.

Has been hitherto found only in Bohemia.

Observations.

Brochant has followed several of the German mineralogists in considering the fossil of Menil Montant near Paris as identical with the polier slate of Werner. It differs from it, however, not only in oryctognostic, but in geognostic characters*.

* We have to expect from Daubisson, the only Frenchman who has studied the Wernerian geognostic, an account of the interesting country in the vicinity of Paris. The occurrence of the peculiar fossil, erroneously called polier slate, with its imbedded tuberosc semi-opal, the superincumbent gyps, containing remains of quadrupeds, shew that the rocks in that quarter constitute a peculiar formation, different from any described by Werner. It is probably newer than the newest stötz trap, and nearly cotemporaneous with the Wehrauer formation of limestone and ironstone, which lies over alluvial land.

THIRTEENTH SPECIES.

Tripoli.

Trippel.—*Werner*.

Tripela, *Wall.* t. 1. p. 94.—*Trippel*, *Wid.* p. 353.—*Tripoli*, *Kirw.* vol. 1. p. 202. *Id.* *Efner*, b. 2. f. 631. *Id.* *Emm.* b. 1. f. 307.—*Id.* *Nap.* p. 210.—*Id.* *Lam.* t. 2. p. 457.—*Le Tripoli*, *Broch.* t. 1. p. 379.—*Lava coctile tripoleene et thermantide tripoleene*, *Haüy*, t. 4. p. 469.

External Characters.

Its colour is yellowish grey, which passes into ash grey.

Occurs only massive.

Internally it is dull.

Fracture pretty coarse earthy. *Imperfectly slaty*

Fragments indeterminately angular, and blunt-edged.

Very soft, approaching to friable.

Feels meagre and rough.

Does not adhere to the tongue.

Not particularly heavy, approaching to light.

Geognostic

Geognostic Situation.

Occurs in veins and beds in floetz rocks, and probably also in alluvial land.

Geographic Situation.

It is found in beds in the coal works of Thuringia; in those of Potschappel near Dresden; in Derbyshire, it occurs in veins; in Tripoli, (from whence it was first brought and derived its name), where it also forms veins. It is said to be also found in Russia, Westphalia, Flanders, Heflia, Bohemia, and Switzerland.

Use.

When reduced to powder, it is employed for polishing metals, marbles, and other minerals. It is also used for polishing glass.

Observations.

1. It was at one time believed to be a volcanic product, but the assertion is now fully disproved.

2. It

2. It appears to be an extremely fine mixture of clay and sand.

FOURTEENTH SPECIES.

Alumstone.

Alaunstein.—*Werner*.

Calcareus aluminaris albus, *Wall.* t. 2. p. 34.—Alaunstein, *Wid.* p. 399.—Pietra d'allume, *Nap.* p. 266.—Alumini-
lite, *Lam.* t. 2. p. 113.—La pierre alumineuse, *Brock.*
t. 1. p. 381.

External Characters.

Its colour is sometimes greyish white, sometimes light yellowish grey.

Occurs massive, and in considerable masses.

Shews a tendency to crystallization.

Internally it is dull.

Fracture uneven, approaching to fine earthy.

Fragments.

Fragments indeterminately angular, blunt edged.

Soft, passing to friable.

Light.

Although Werner has given the preceding description as that of alumstone, he does not venture to affirm that he has described the true Roman alumstone, as it is extremely difficult to procure specimens of it, its exportation being forbidden by the most severe punishments.

Geographic Situation.

It is found at Tolfa near Rome, where it is said to form a whole hill. Werner has also a specimen which is said to have been found in Hungary.

Observation.

Werner supposes that it is intermediate between claystone and limestone, from the resemblance it bears to both of these fossils.

Use.

From the alum stone of Tolfa the famous Roman alum is manufactured.

FIFTEENTH SPECIES.

Alum earth.

Alaunerde.—*Werner*.

Terra aluminaris, *Wall.* t. 2. p. 32.—Alaunerde, *Wid.* p. 398.—*Id. Esner*, b. 2. f. 647. *Id. Emm.* b. f. 299.—Aluminite bitumneux, *Lam.* t. 2. p. 116.—La terre alumineuse, *Broch.* t. 1. p. 383.

External Characters.

Colour blackish brown and brownish black.

Massive.

Dull, sometimes glimmering, but this probably owing to an intermixture of mica.

Fracture earthy, with a tendency to straight flaty.

Breaks into tabular pieces.

Streak shining.

Feels a little meagre, and somewhat greasy.

Mild.

Intermediate between very soft and friable.

Light.

Chemical Character.

When exposed to heat it burns with a flame, and when left some time exposed to a moist atmosphere it becomes warm, and at length takes fire.

Geognostic Situation.

It occurs frequently in beds of great magnitude, in alluvial land, and sometimes also in the floetz trap formation.

Geographic Situation.

It is found in Bohemia, Saxony, Austria, Naples, Hungary, and in the Vivrais in France.

Use.

It is lixiviated to obtain the alum it contains; it is even sometimes used for fuel.

Observations.

Observations.

1. It bears a strong resemblance to bituminous wood, and probably passes into it. May it not be considered as a subspecies of bituminous wood?

2. We must be careful not to confound it with alum stone or alum slate, from which it differs very much.

 SIXTEENTH SPECIES.

Alum Slate.

Alaunschiefer.—*Werner.*

Werner divides this species into two subspecies

1. Common alum slate.
2. Glossy alum slate.

FIRST SUBSPECIES

Common Alum Slate.

Gemeiner Alaunfchiefer.—*Werner*.

Schistus aluminaris? *Wall.* t. 2. p. 32.—Variety of alum slate, *Wid.* p. 396.—Alaunfchiefer, *Esner*, b. 2. f. 651.—Gemeiner alaunfchiefer, *Emm.* b. 1. f. 296.—Schisto aluminoso, *Nap.* p. 264.—Variété de l'argile schisteuse, *Haüy*.—Le schiste alumineux, commun, *Broch.* t. 1. 386.

External Characters.

Its colour is intermediate between greyish and bluish black, which falls strongly into grey.

Occurs massive, and sometimes in balls, which are immersed in the massive.

Internally it is more or less glimmering.

Fracture pretty perfectly straight flaty.

Fragments tabular.

Retains its colour in the streak, but becomes a little shining.

Soft.

Not

Not particularly brittle.

Easily frangible.

Not particularly heavy.

Chemical Characters.

When exposed to the air it acquires a sweetish aluminous taste, and effloresces.

SECOND SUBSPECIES.

Glossy Alum Slate.

Gläzaender Alaunschiefer.—*Werner*.

Variety of Alaunschiefer, *Wid.* p. 395.—Glänzender a. schiefer, *Emm.* p. 297.—Alaunschiefer, *Eßner*, b. 2. f. 651.—Variété de l'argile schisteuse, *Haüy*.—La schiste alumineux éclatante, *Broch.* t. 1. p. 388.

External Characters.

Colours intermediate between bluish and iron black. On the rents it is marked with a tempered steel and peacock-tail tarnish.

Occurs massive.

The lustre of its principal fracture is shining, gliftening and semi-metallic. Cross fracture glimmering.

Fracture pretty straight, and partly waved, flaty.

Fragments tabular, and often run into wedge-shaped.

In other respects resembling the former, only a little more aluminous.

Geognostic

Geognostic Situation of Alum Slate.

It occurs in beds and strata, which are subordinate to the newest clay slate, and also in transition mountains. It sometimes, although rarely, forms veins.

Geographic Situation.

It occurs in Saxony, Bohemia, Hungary, France, Scotland, as in the valley of the lead hills, in the high mountains in the neighbourhood of Moffat, and in many other places among the great mass of transition rocks in the south of Scotland. Esmark observed, at Felsobanya in Hungary, a vein of alum slate about two fathoms wide.

Uses.

Alum earth, as already mentioned, by exposure to the influence of the weather affords alum; but this species, before it yields alum must be burnt. Besides alum earth, alum stone, and alum slate, other fossils afford alum; thus some varieties of fossil coal are pretty productive, and at Schonon in Sweden it is prepared from a variety of bituminous shale.

Observations.

Observations.

1. Alum earth is distinguished from alum slate by its brownish black colour, want of lustre, inferior hardness and inflammability.

2. At Whitby in Yorkshire, there are very extensive alum mines; but we are as yet ignorant, not only of the species of the fossil from which the alum is obtained, but also of the formation to which it belongs.

SEVENTEENTH SPECIES.

Bituminous Shale.

Brandſchiefer.—*Werner*.

Schistus pinguis? *Wall.* t. 1. p. 354.—Schistus carbonarius, *Id.* p. 358.—Brandſchiefer, *Wid.* p. 394.—Bituminous shale, *Kirw.* vol 1. p. 183.—*Ffner*, b. 2. f. 658. *Emm.* b. 1. f. 289.—Shisto bituminoso, *Nap.* p. 263.—Argilite bitumineux, *Lam.* t. 2. p. 116.—Variété de Par-gile ſchiſteuſe, *Hauy*.—Leſchiſte bitumineux, *Broch*, t. 1. p. 389.

External Characters.

Its colour is browniſh black.

Occurs only maſſive.

Internally its luſtre is glimmering.

Fracture pretty perfectly ſtraight, but ſomewhat thin, flaty.

Fragments tabular.

Streak ſhining; but its colour is not altered.

U u

Very

Very soft.

Rather mild.

Feels rather greasy.

Easily frangible.

Not particularly heavy, approaching to light.

Chemical Character.

When laid on burning coal it emits a pale flame, sulphureous odour, and black smoke, becomes white, and loses a considerable portion of its weight.

Geognostic Situation.

It occurs along with slate clay, in the coal formation. It passes on the one hand into coal, on the other into slate clay.

Geographic Situation.

It is found in Bohemia, Poland, Silesia, England, Scotland, and in general wherever the independent coal formation makes its appearance.

Observation.

Observations.

1. In this species the clay is combined with bitumen, but in alum slate with carbone.
2. It is the ampelitis of the ancients.

EIGHTEENTH SPECIES.

Drawing Slate, or black Chalk.

Zeichenschiefer.—*Werner*.

Schistus pictorius nigrica, *Wall.* t. 1. p. 358.—Zeichenschiefer, *Wern. Cronst.* p. 206. — Black chalk, *Kirw.* vol. 1. p. 195.—Schwartzte kreide, *Efner*, b. 2. f. 661, —Schiefer, *Id. Emm.* b. 1. f. 303. — Schisto pittorio, *Nap.* p. 269.—Melantirite ou crayon noire, *Lam.* t. 2. p. 112.—Argile schisteuse graphique, *Haüy*, t. 4. p. 447. —Le schiste a dessiner, *Broch.* t. 1. p. 391.

External Characters.

Its colour is greyish black, which sometimes approaches to blueish black.

Massive.

Lustre of the principal fracture is glimmering, but the cross fracture dull.

Principal fracture generally slaty, the cross fracture fine earthy.

Fragments

Fragments generally tabular, and sometimes splintery.

Opaque.

Colours and writes.

Its streak is glistening, but does not alter the colour.

Soft, passing into very soft.

Mild.

Easily frangible.

Feels meagre but fine.

Not particularly heavy, approaching to light.

Chemical Characters.

According to Lelievre before the blow pipe and without addition becomes covered with a flight varnish.

Constituent Parts.

Silica	64,0
Alumina	11,25
Carbone	11,0
Oxyd of iron	2,75
Water	7,50

96,35

According to *Wiegleb. Crells. Ann.* 1797. f. 485.

Geognostic

Geognostic Situation.

It occurs in primitive mountains, and is subordinate to clay slate. It is usually accompanied by alum slate, with which it is indeed nearly allied.

Geographic Situation.

It is found in France, Bareuth, Spain, Italy, Iceland and Scotland, as in the island of Isla, one of the Hebrides*.

Use.

When of a middling degree of hardness it is used for drawing. The best is said to be found in Spain and Italy.

Observation.

It burns red:

* Mineralogy of the Scottish isles.

NINETEENTH SPECIES.

Whet Slate.

Wetzschiefer.—*Werner*.

Schistus cotricula, *Wall.* t. 1. p. 353.—Wetzschiefer, *Wid.* p. 402.—Novaculite, *Kirw.* vol. 1. p. 238.—Wetzschiefer, *Efner*, b. 2. f. 664. *Id. Emm.* b. 1. f. 305.—Pietra cote, *Nap.* p. 270.—*Cos. Lam.* t. 2. p. 105.—Le schiste a aiguifer, *Broch*, t. 1. p. 393.—Argile schisteuse novaculaire, *Hauy*, t. 4. p. 448.

External Characters.

Its most common colour is greenish grey, it occurs also mountain, asparagus, olive, and oil green.

Massive.

Internally weakly glimmering, almost dull.

Fracture is in the large flaty, in the small splintery.

Fragments tabular.

Translucent on the edges.

Semihard, passing into soft.

Feels rather greasy.

Not particularly brittle.

Not

Not particularly heavy.

Specific gravity—2,722.

Geognostic Situation.

It occurs in primitive mountains, and is subordinate to clay slate.

Geographic Situation.

It is found at Lauenstein in the Margraviate of Ba-reuth, in Saxony, as at Seiferdorf near Freyberg, in Bohemia, and the Levant, from whence it was first brought and made known in Europe.

Use.

When cut and polished it is used for sharpening knives and other instruments.

Observations.

1. Werner suspects, from its green colour, greasy feel, and its passing into indurated talc, that it contains magnesian earth.

2. This

2. This species does not include every kind of whetstone which is in use, for some are of clay slate, or compact limestone, others are of sandstone.

3. It is distinguished from all other flaty fossils by its fracture.

TWENTIETH SPECIES.

Clay Slate.

Thonschiefer.—*Werner*.

Schistus ardesia tegularis, *Wall.* t. 1, p. 351.—Thonschiefer, *Wid.* p. 391.—Argillite, *Kirw.* t. 1, p. 234.—Killas, *Id.* p. 237. *Id. Emm.* t. 1. p. 284. *Efner*, b. 2. f. 667. Ardoise, *Lam.* p. 110.—Le schiste argileux, *Broch.* t. 1, p. 395 —Primitive schistus of mineralogists.

External Characters.

Its principal colour is grey, of which the varieties are yellowish, bluish, greenish*, smoke, ash and pearl grey. The smoke, bluish, and ash grey are the most common. From greenish grey it passes into a kind of blackish green; from dark smoke grey it passes into greyish black, and from pearl grey into brownish red.†

* The greenish varieties seem to be verging on talc slate.

† Houses roofed with this variety appear as if covered with copper.

Sometimes spotted.

Occurs massive.

Internally its lustre is glistening, bordering on shining, and sometimes glimmering, and is resinous approaching to pearly.

Fracture more or less slaty, and some varieties approach to foliated, and others to compact. The slaty is either straight or undulatingly curved and the latter has a two-fold obliquely intersecting cleavage*.

Fragments tabular, and also large splintery †.

Affords generally a greyish white streak.

Opaque.

Soft.

Very mild.

Some varieties feel a little greasy.

Pretty easily frangible.

Not particularly heavy.

Geognostic Situation.

It occurs in vast strata in primitive and transition mountains, and Werner observed two mighty veins of it in the mountains of Schneeberg, and others in the mountains of Hartenstein.—*Wern. Gänge.*

* In the forest of Tharand, in Upper Saxony, I observed clay slate which appeared to be composed of globular, and these again of concentric lamellar distinct concretions.

† The large splintery is named splinter slate.

Geographic Situation.

It is found very universally distributed; hence its localities are very numerous; we shall therefore only mention a few of those of Scotland. At Easdale and the neighbouring isles there are great depositions of transition? clay slate: between Elvanfoot and Moffat there are strata of transition slate, which alternate with grey wacce; near the Crook, between Edinburgh and Moffat, there are quarries situated in the same species of rock; and in many other parts of the great chain of mountain groupes that traverse the south of Scotland it is to be found. The clay slate of Balychulish in Argyleshire, as far as I can judge from specimens and information, appears on the contrary to belong to the primitive rocks.

Use.

When it splits into thin and firm tables it is employed for roofing houses. The greyish black straight flaty variety is used for writing on; and the splintery for pencils, and some varieties are so firm that they can be used as whet-stones.

Observation.

Observations.

1. It is to be observed passing into several congenerous fossils; thus the oldest primitive clay slate has a considerable degree of lustre, shews a beginning scaly aspect, and passes into mica slate; the greenish varieties, by an increase of their proportion of magnesian earth, and consequent alteration of external characters, pass into whet slate, chorite slate, and indurated talc. It may even pass into slate clay, but I do not know that this has ever been observed.

2. In places where the splintery variety is found, the separated masses appear like rotten wood,

TWENTY-FIRST SPECIES.

Lepidolite.

Lepidolith.—*Werner*.

Id. Wid. p. 378. *Id. Kirw.* vol. 1. p. 208. *Id. Emm.* b. 3. f. 324. *Id. Estner,* b. 2. f. *Id. Nap.* p. 167. *Lam.* t. 2. p. 315. *Broch.* t. 1. p. 399.

External Characters.

Its colour is a kind of peach-blossom red that verges on lilac blue; it also passes into pearl grey and yellowish grey. The yellowish grey colour is however probably only accidental, and owing to the loss of the colouring matter.

Occurs massive.

Internally its lustre is glistening, passing into shining.

Fracture in the small foliated, in the great splintery.

Fragments indeterminately angular, blunt edged.

Occurs in small and fine grained distinct concretions.

Translucent.

Mild.

Soft.

Easily frangible.

Not particularly heavy.

Specific gravity.—*Klaproth*, 2,816.—*Haüy*, 2,854.

Chemical Characters.

Before the blow pipe it melts easily without intumescence, into a white semitransparent, vesicular enamel.

Constituent Parts.

Silica	54,50	54,0
Alumina	38,25	20,0
Oxyd of iron	75	1,0
— of Manganese	75	3,0
Potash	4,0	18,0
Fluat of Lime		4,0
Loss	2,50	
	<hr/>	<hr/>
	100	100

According to *Klaproth*, b. 2. f. 195. *Vauquelin*. *I. d. M.*
N^o 51. p. 235.

Geognostic and Geographic Situations.

It has been hitherto found only at Rozena in Moravia, where it lies in gneiss, but whether it is of contemporaneous or posterior formation, I do not know. It appears sometimes to be intermixed with scales of mica.

Observations.

1. It was at first considered as a subspecies of zeolite, afterwards as a variety of foliated gypsum, and some continue to arrange it with mica.
2. The supposed crystallized variety is red coloured schorlous beryll,

TWENTY-SECOND SPECIES.

Mica or Glimmer.

Glimmer.—*Werner.*

Mica, *Wall.* t. 1. p. 383.—Glimmer, *Wid.* p. 403.—Mica, *Kirw.* vol. 1, p. 210.—Glimmer, *Esfner*, b. 2. f. 673. *Id. Emm* b. 1. f. 31. *Id. Lam* p. 337.—Mica, *Nap.* p. 272.—Le Mica, *Broch.* t. 1. p. 402.

External Characters.

Its most common colour is grey, from which it passes on the one side into brown, on the other into black. Of grey it presents the following varieties, yellowish, ash, and greenish grey, which latter passes into blackish green; the yellowish grey passes on the other side into silver white, and into pinchbeck brown and brownish black.

Occurs massive, disseminated, in thin tables and layers in other stones, also crystallized.

1. In equilateral six-sided tables, with smooth terminal and lateral planes.

Y y

2. In

2. In six-sided prisms.

The crystals are generally small, seldom middle-sized, and either intersect one another, and form druses, or are singly imbedded.

Surface of the crystals splendent; internally the lustre is shining and splendent, generally pearly and resinous, and in some varieties semi-metallic, even sometimes passing into metallic.

Fracture perfectly foliated, single cleavage, commonly undulatingly curved foliated, sometimes plane foliated, also floriformly and diverging radiated, and the rays plumosely streaked.

Fragments generally tabular, and indeterminately angular.

The massive sometimes occurs unseparated, but the foliated in coarse and small grained distinct concretions; the radiated occurs in wedge-shaped prismatic concretions.

In thin plates it is transparent, but in larger pieces only translucent on the edges.

Semi-hard passing into soft.

Mild.

Feels smooth but not greasy.

More or less easily frangible.

Elastically flexible.

Not particularly heavy.

Specific gravity—*Blumenbach*, 2,934.—*Briffon*, 2,79

Chemical Character.

According to Lelievre it is converted with difficulty into an enamel, when exposed to the blow pipe.

Constituent Parts.

Silica	40	38	50
Alumina	46	28	35
Oxyd of iron	9	14	7,0
Magnesia	5	20	1,35
Lime			1,33
Lofs			5,32

100	100	100
<i>Bergman.</i>	<i>Kirwan.</i>	<i>Vauquelin.</i>

Geographic Situation.

It is one of the constituent parts of granite, gneiss and mica slate, and it is also sometimes found in syenite, porphyry, and wacce. Notwithstanding its occurrence in wacce it is to be considered as nearly peculiar to the primitive mountains, what is found in the newer formations being evidently derived from primitive rocks by disintegration.

Geognostic Situation.

It is found wherever the rocks already mentioned occur, which is in almost every quarter of the globe.

Use.

It was formerly used instead of glass for windows and lanterns, and till very lately it was used in the Russian navy, as its great elasticity rendered it less liable than glass to break on the discharge of cannon. The mica for this purpose was dug in the neighbourhood of Irkutsk and Ilmena in Siberia.

Observation.

The blackish green variety is the link which connects it with chlorite slate.

Handwritten notes:
 2, 5, 10, 30 for a specimen
 to be used in the collection. Paper & other
 39.00 for specimens - 10.00 used
 as a specimen for papers containing
 with paper, 10.00

TWENTY.

TWENTY-THIRD SPECIES.

Pot Stone.

Topfstein.—*Werner.*

External Characters.

Its colour is greenish grey, of different degrees of intensity; the deeper varieties pass to leek green.

Occurs massive.

Lustre internally glistening and pearly.

Fracture sometimes curved foliated, sometimes imperfectly flaty.

Fragments tabular.

The foliated shews imperfect coarse and fine grained distinct concretions,

Translucent on the edges, and sometimes opaque.

Soft, and sometimes very soft.

Nearly mild.

Feels greasy.

Very difficultly frangible.

Geognostic Situation.

It is found in beds along with serpentine ? or nidular in it.

Geographic Situation.

It is found at Como in the Grisons, and an imperfect kind at Zöblitz in Saxony. It is said to be found in Hudson's Bay,

Observations.

1. It is very nearly allied to indurated talc, with which it used formerly to be confounded.
2. As it is very refractory in the fire it can be used for the lining of furnaces, and as it is easily turned, various culinary vessels may be made of it.

TWENTY-FOURTH SPECIES:

Chlorite.

Chlorit.—*Werner*.

This species is divided by Werner into four sub-species, *viz.* 1. Chlorite earth. 2. Common Chlorite. 3. Foliated Chlorite. 4. Chlorite Slate.

FIRST SUBSPECIES.

Chlorite Earth.

Chlorit erde.—*Werner*.

External Characters.

Its colour is intermediate between dark mountain green and blackish green.

It is composed of small pearly glimmering scaly particles ; it even occurs loose.

It is very coherent ; gives a mountain green and shining streak.

Colours a little.

Feels rather greasy.

Not particularly heavy, almost light.

Geognostic Situation.

occurs in primitive mountains, and principally in clay slate.

Geographic

Geographic Situation.

It is found in Saxony, at Altenberg and Ehrenfriederdsdorf, in Switzerland and Savoy.

Observation.

It bears a striking resemblance to green earth.

SECOND SUBSPECIES.
Common Chlorite.**Gemeiner Chlorit.—Werner.***External Characters.*

Colour blackish green, which approaches to mountain green.

Occurs massive and disseminated.

Internally its lustre is glimmering and glistening.

Z z

Fracture

Fracture foliated, and very fine foliated passing into earthy.

Fragments indeterminately angular, blunt-edged.

Colour of the streak lighter green.

Soft, bordering on very soft.

Opaque.

Mild.

Feels rather greasy.

Easily frangible.

Not particularly heavy.

Geognostic Situation.

It is frequently found in metaliferous veins; and also in none metallic veins of the oldest formation.

Geographic Situation.

Is found in the Stockwerkes of Geyer and Altenberg in Saxony, and in Zinnwald.

THIRD SUBSPECIES.

Chlorite Slate.

Chlorite Schiefer.—*Werner.*

External Characters.

Its colour is blackish green, of various degrees of intensity.

Only massive.

Internally it is glistening and resinous.

Fracture sometimes curved, sometimes undulatingly flat; some varieties pass to scaly foliated, and those have the greatest degree of lustre.

It has a two-fold cleavage.

Fragments flaty.

Opaque.

Gives a mountain green streak, and changes its lustre a little.

Perfectly mild.

Feels rather greasy.

Not particularly heavy, heavier than common chlorite.

Geognostic Situation.

It is one of the newer primitive rocks, and occurs in beds subordinate to clay slate.

Geographic Situation.

It is found in Norway, Sweden, Stiria, the Tyrol, Switzerland, in Scotland, in the islands of Arran and Bute, banks of Loch Lomond, Loch Tay, &c*.

Observations.

1. It sometimes passes into mica slate, and hornblende slate.
2. It very frequently contains imbedded octaedral crystals of magnetic iron stone, often also garnets. The occurrence of magnetic iron stone is characteristic of this subspecies.

* Mineralogy of the Scottish isles.

FOURTH SUBSPECIES.

Foliated Chlorite.

Blättriger Chlorit.—*Werner.*

External Characters.

Colour is intermediate between dark mountain and blackish green.

Occurs massive, disseminated, but almost always crystallized.

1. Six-sided table.
2. Cylinder terminated by two cones.
3. Two truncated cones joined base to base.

If we suppose the six-sided table N^o 1. to revolve around an axis which passes through its two opposite angles, the figure N^o 2. will be formed; but if it revolves around an axis which passes through the two opposite sides, the figure N^o 3. will be produced.

Externally the surface is streaked and glistening.

Crystals are generally small and middle sized, and occur singly implanted.

Internally its lustre is shining and pearly, approaching to resinous.

Fracture

Fracture foliated, generally curved foliated, simple cleavage.

Fragments tabular.

Translucent on the edges, or opaque.

Soft, passing into very soft.

Mild.

The folia are commonly flexible.

Feels rather greasy.

Easily frangible.

Not particularly heavy.

The streak is lighter.

Constituent Parts.

Silica	0,350	0,
Magnesia	0,299	0,
Alumina	0,180	0,
Oxyd of iron	0,97	0,
Water	0,27	0,

953

Lampadius' handbuch zur chemischen analyse der mineral Körper, s. 229.

Geognostic Situation.

Occurs in veins of the oldest formation that traverse granite, gneiss, and mica slate,

Geographic

Geographic Situation.

It has been hitherto found only on the mountain of St. Gothard in Switzerland, and in the island of Jura, one of the Hebrides*.

* Mineralogy of the Scottish isles.

TWENTY-FIFTH SPECIES.

Hornblende.

Hornblende.—*Werner*.

This species is divided by Werner into four sub-species, *viz.* 1. Common hornblende. 2. Labrador hornblende. 3. Basaltic hornblende. 4. Hornblende flate.

FIRST SUBSPECIES:

Common Hornblende.

Gemeiner Hornblende.—*Werner*.

Hornblende, *Kirw.* vol. 1. p. 213.—Gemeiner hornblende; *Esner*, b. 2. f. 699.—*Id. Emm.* b. 1. p. 322. and b. 3. f. 267.—*Orniblanda commune*, *Nap.* p. 276.—*La hornblende commune*, *Broch.* t. 1. p. 415.

External Characters.

It is commonly greenish black, or raven black, which in some varieties approaches to greyish and velvet black; in others to dark greenish grey. Sometimes the blackish green verges on leek green.

Occurs massive, disseminated, and sometimes in long and broad prismatic crystals, which are imbedded, intersect one another, and are sometimes scopiformly aggregated: on this account it is difficult to determine their figure. *Werner* supposes that they are oblique four-sided prisms.

Internally its lustre is generally shining, sometimes passing to splendid, and nearly pearly.

Fracture commonly foliated, sometimes also small and broad radiated; the foliated is almost always straight foliated, and the radiated is generally promiscuously and scopiformly diverging.

The fracture surface is longitudinally streaked. The foliated has a double obliquely intersecting cleavage.

Fragments are usually indeterminately angular, blunt edged, but the large foliated approach to rhomboidal.

Occurs in large, coarse, small, and fine grained distinct concretions.

The black varieties opaque, the green generally translucent on the edges.

Gives a mountain green, falling into greenish grey streak.

Semi-hard, passing to soft.

Difficultly frangible.

Not particularly heavy, approaching to heavy.

Specific gravity—3,600 to 3,830, *Kirwan*.

When moistened it exhales a bitter smell.

Chemical Characters.

It melts easily without addition before the blow pipe into a greyish black glass.

ANALYSE

Constituent Parts.

Silica	37,0	48,83	37,0
Alumina	22,0	27,0	27,0
Magnesia	16,0	17,50	13,9
Lime	2,0	16,66	3,0
Oxyd of iron	23,0	17,50	25,0
Lofs			3,0
	100	1,49	100

Kirwan. Min. vol. 1. p. 213. Wiegleb. Chemische Hermann. Berl. Beobacht. 79. Annalen, 1787.

Geognostic Situation.

It forms one of the essential ingredients of several mountain rocks; is sometimes accidentally disseminated in others; and occurs in beds. Thus it forms one of the principal ingredients of syenite and primitive greenstone, also of transition and floetz greenstone: and it occurs accidentally in granite, gneiss, mica slate, and limestone; and when in beds, it is sometimes accompanied with ores, as magnetic iron stone, iron pyrites, &c.

A fine variety of syenite is found in the following...

Geographic Situation.

It is found very widely extended, as in Norway, Sweden, England, Scotland, Saxony, Bohemia, Silesia, Hungary, Alps, Siberia, &c.

Use.

When it is free of admixture with quartz and felspar, it forms an excellent flux for iron ores.

SECOND SUBSPECIES.

Labrador Hornblende.

Labradorische Hornblende.—*Werner*,*External Characters.*

It is usually brownish black, greenish black, copper red*, and feldom greyish black.

Occurs massive, disseminated, and in rolled pieces.

Internally its lustre is from strongly glimmering to shining, and is semi-metallic.

Fracture nearly the same with hornblende, only it is usually curved foliated†.

Fragments indeterminately angular, yet sometimes approach to rhomboidal.

* The copper red colour, which is characteristic of this species, is suspected by Werner to be accidental, and probably produced in the same manner as that of the Labrador stone.

† Haüy, in a Memoir on labrador hornblende, published in the 7th number of the Annales du museum national, asserts, that the cleavage is not only rectangular, but that that it is obliquely intersected by another.

Occurs

Occurs in large, coarse, small, and sometimes thin lamellar distinct concretions.

Opaque.

Semi-hard.

Pretty easily frangible.

Specific gravity—3,3857.

Geographic Situation.

Is found in the island of St Paul, on the coast of Labrador,

THIRD SUBSPECIES.

Hornblende Slate.

Hornblende schiefer.—*Werner*.

Schistose hornblende, *Kirw. v. 1. p. 222.*—La hornblende schisteuse, *Broch. t. 1. p. 428.*

External Characters.

Its colour is intermediate between greenish and raven black.

It is massive.

Internally its lustre is shining and glistening, approaching to pearly.

Fracture in the great slaty, in the small promiscuous radiated.

Fragments sometimes tabular, and sometimes indefinitely angular.

Gives a greenish grey streak.

Semi-hard, passing into soft.

Not particularly frangible.

In other characters it agrees with the foregoing.

It is not always pure, but is frequently mixed with felspar and mica.

Geognostic Situation.

It occurs in more or less mighty beds in primitive rocks, particularly in clay slate; also in gneiss and mica slate.

Geographic Situation.

It is found in Norway, Sweden, Scotland*, at Port-foy, &c.; Saxony, at Hartmanndorf, Chemnitz, &c.

* Mineralogy of the Scottish isles.

FOURTH SUBSPECIES.

Bafaltic hornblendē.

Bafaltische hornblende.—*Werner*.

Bafaltische hornblende, *Wid.* p. 417. —Bafaltine, *Kirw.* vol. 2. p. 219.—Bafaltische hornblende, *Estner*, b. 2. f. 719.—*Id Emm.* b. 1. f. 330. and b. 3 f. 269.—Orniblanda bafaltica, *Nap.* p. 281.—Amphibole, *Lam.* t. 2. p. 330.—Amphibole cryftallifée, *Hauy*, t. 3. p. 58.—La hornblende bafaltique, *Broch*, t. 1. p. 424.

External Characters.

Its colour is velvet black.

Occurs almost always in fingle imbedded cryftals, and thefe are

1. Equilateral fix-fided prifms flatly acuminated on both extremities by three planes, which are fet contrary-wife on the alternate lateral edges.
2. A fimilar prifm, flatly acuminated on one extremity by four planes, which are fet on the four oppofite lateral planes, on the

other bevilled, the bevilling planes set on the two opposite lateral edges.

3. Similar prism at one extremity flatly acuminate by three planes, which are set on the alternate lateral edges, on the other bevilled, the bevilling planes set on the opposite lateral edges.

Crystals small and middle sized.

Surface smooth.

Lustre of the principal fracture splendid, cross fracture glistening and vitreous.

Principal fracture perfectly straight foliated, with a double obliquely intersecting cleavage; cross fracture fine grained uneven approaching to small conchoidal.

Fragments generally indeterminately angular, sometimes also rhomboidal.

Always opaque.

Semi-hard.

Pretty brittle.

Easily frangible.

Not particularly heavy.

Specific gravity.—3,250, *Hauy*.—From 3,150 to 3,220, *Reufs*.—3,333, *Kirwan*.

Chemical Character.

Before the blow pipe it melts into a black glass, but is more refractory than common hornblende.

Constituent

Constituent Parts.

Silica	58,0
Alumina	27,0
Iron	9,9
Lime	4,0
Magnesia	1,0
	<hr/>
	99,0

According to *Bergman*, Opusc. t. 3, p. 207.

Geognostic Situation.

It is found commonly imbedded in basalt and wacce, and also wrapped in lava.

Geographic Situation.

It is found in Saxony, Bohemia, Scotland, Italy, &c.

Observations.

1. It resists decomposition longer than basalt, hence we frequently find good crystals dispersed in the clay

clay which is formed by the decomposition of basaltic rocks.

2. It is remarkable that common hornblende is difficultly frangible, and this species easily frangible.

3. It is often confounded with augite, from which, however, it differs in many characters. Augite has always a green colour, which is not the case with basaltic hornblende, it is harder, has rather an indistinct cleavage, gives no streak, has a resinous lustre, and its crystallization is different.

TWENTY-SIXTH SPECIES,

Bafalt.

Bafalt.—*Werner*.

Id., *Wid.* p. 423.—Figurate trap, *Kirw.* vol. 1. p. 231.—
Bafalt, *Eftner*, b. 2. f. 726, *Id.* *Emm.* b. 1. f. 339.—
Bafalto, *Nap.* p. 284.—Le bafalte, *Broch.* t. 1. p. 430.—
Haüy, t. 4. p. 474.

External Characters.

Its most common colour is greyish black, of various degrees of intensity; from this it passes into ash grey, which inclines to brown, and even in some varieties approaches to raven black.

Occurs massive, in blunt and rolled pieces, and sometimes vesicular.

Internally it is generally dull, seldom feebly glimmering, owing to an admixture of foreign particles.

Fracture most commonly coarse grained uneven, sometimes also imperfectly large conchoidal and fine splintery,

splintery, and some rare varieties verge on even and earthy.

Fragments indeterminately angular, not very sharp edged.

Occurs almost always in distinct concretions. These are generally columnar, and from a few inches to several fathoms, even to upwards of a 100 feet in length; are sometimes straight, sometimes bent, and either parallel or diverging. In mountains these concretions are collected into larger groupes, and many of these groupes or concretions together form a hill or mountain. Sometimes the columns are articulated, and the joints have concave and convex faces.

Besides columnar it occurs also in large globular distinct concretions, which are again composed of concentric lamellar concretions.

Some varieties are composed of large, coarse, and fine grained distinct concretions.

Sometimes also tabular.

Generally opaque, and sometimes translucent on the edges.

Gives a light ash grey streak.

Semi-hard, bordering on hard.

Brittle.

Very difficultly frangible.

Intermediate between not particularly heavy and heavy.

Specific gravity.—3,000, *Bergman*.—2,864, *Briffon*.—2,979, *Kirwan*.

Chemical Characters.

Before the blow pipe it melts easily without addition into an opaque black glass. According to Dr Kennedy, the basalt of the castle rock of Edinburgh softens at 45° of Wedgewood; that of Staffa at 38° *, and I obtained similar results with the basalt of Arran, as is mentioned in my account of that island.

Constituent Parts.

Silica	50,0	44,50	48,0
Alumina	15,0	16,75	16,0
Oxyd of Iron	25,0	20,0	16,0
Lime	8,0	9,50	9,0
Magnesia	2,0		
Oxyd of Manganese		0,12	
Moisture and vol. matter			5,0
Soda		2,60	4,0
Water		2,00	1,0
		99,72	99,0

According to *Bergman*. Basalt of the Hassenberg. Basalt of Staffa, according to *Klaproth*. according to *Kennedy*†.

* Edinburgh Transactions for 1799.

† We have now to deplore the death of this very able analyst, whose skill in conducting, and ingenuity in devising experiments was only rivalled by the excellence of a Kirwan, a Hatchett, and a Klaproth.

Geognostic

Geognostic Situation.

According to the observations of Werner, it is exclusively confined to the floetz trap formation. Charpentier, however, in his work entitled *Beobachtungen über die lagerstätte der Erze, &c.* informs us that he found basalt in mica slate near Grobsdorf in Silesia, and in gneiss in the Fichtelgebirge; but these beds, on a more attentive examination, have been found to be very compact dark coloured greenstone.

Occurs in strata, beds, and veins, of which we have numerous examples in Scotland, as we find mentioned in an excellent but little known work, *The Mineral Kingdom*, by Williams; in Professor Playfair's illustrations of the Huttonian Theory; Faujas de St Fond's travels, and in my outline of the Mineralogy of the Scottish isles.

Geographic Situation.

It occurs in almost every quarter of the globe. In Europe, it has been observed in Iceland, Faroe islands, Sweden, (of which the famous Kennekula and Hünneberg are in part composed); Scotland, in vast abundance; Ireland, particularly in the northern provinces; England; Saxony, where it occurs particularly beautiful at Stolpen, and instructive at Scheibenberg.

berg, where Werner made the important observations that gave us the first true idea of its mode of formation; Silesia, of which the remarkable deposition in the Schnee gruben highly elevated on the Riefen gebürge, has excited so much inquiry, and which require the acuteness of a Werner to elucidate and explain. Bohemia, where the remarkable hill called Camerbühl, composed of vesicular basalt long passed for volcanic; Franconia, Swabia, Hungary; many places on the banks of the Rhine; Auvergne in France, where varieties of vesicular basalt have been mistaken for lava, even by the acute Dolomieu, and by Von Buch, a pupil of Werner. Lugano, in Italian Switzerland, Euganean mountains; Catanea; Monte Servato, near Barcelona; and in the neighbourhood of Lisbon.

In Asia it has been observed by Neibuhr, at Hadie Andjor in Yemen; Kufma; and Beit-El-Taki; and by Patrin on the banks of the Amoar in Dauria.

Of Africa I can give no localities, nor of America. In Australasia, it has been hitherto found only in New Holland.

In Polynesia it has been observed, and in Otaheite, Easter island, Owai in the Sandwich islands, and in Kergeulens island.

Use.

It is employed as a building stone, touch stone, as a flux for certain ores of iron, in glass manufactures,

tures, in the making of common green glafs. The vesicular varieties are employed for mill-stones. Although it is harder, more brittle, and less obedient to the chisel, and its colours not so pleasing or durable as marble, yet the ancients, who were acquainted with its greater indestructibility, executed many fine works in it. Pliny has described several fine pieces of sculpture said to have been done in this stone; and the famous statue of Minerva still to be seen at Thebes, is by travellers described as basalt. Many of the antique basalts, which are preserved in collections, are evidently syenite or greenstone.

Observations.

1. Imbedded in it we find basaltic hornblende, olivine, sometimes (when it borders on wacce) mica, also calc spar, felspar, calcedony, and zeolite.

2. The cavities which it sometimes contains have been found filled with water: instances of this kind, observed in Germany, are mentioned by Stucke, and Dr. Richardson of Belfast has observed similar appearances in the basalt of the Giants Causeway.

3. The theory of its formation was long a subject of dispute among mineralogists, but it is now universally admitted to be an aquatic production. An account of its geognostic characters and natural history will be given in the Geognosie.

3. In Scotland it is denominated whin stone, yet this name is not confined to basalt; under it is also included nearly all the other rocks of the trap, syenite, and porphyry formations; and in many places granite, grey wacce, and primitive and transition clay slate have the same appellation. We should therefore agree to banish this vague and unmeaning term from mineralogy.

The name of whin stone is first mentioned in 1750 by the decision of the parliament by De Bois

TWENTY SEVENTH SPECIES.

Wacce.

Wakke.—*Werner*.

Wacken, *Kiow*. vol. 1. p. 223. *Wacke*.—*Efner*. b. 2.
f. 737. id.—*Emm*. b. 1. f. 335. id.—*Nap*. f. 228.
La Wakke.—*Broch*. t. 4. p. 434.

External Characters.

Its colour is greenish grey of various degrees of intensity: from light greenish grey, it passes into ash grey, and verges on yellowish grey. When it passes to basalt, it is greyish black. When it is brownish it is owing to its impregnation with iron ochre.

It occurs sometimes massive, sometimes also vesicular, and the vesiculæ are either filled, when the compound is denominated amygdaloid, or empty.

Is dull, sometimes feebly glimmering.

Fracture in general even, sometimes it runs into imperfectly large and flat conchoidal, sometimes into uneven, even into earthy.

Fragments

Fragments indeterminately, angular rather blunt edged

Always unseparated.

Opaque.

Streak more or less shining.

Mild.

Usually soft; some varieties approach to semi hard.

More or less easily frangible.

Not particularly heavy:

It is characteristic of it that it falls in the open air.

Chemical Characters.

Is said to be equally fusible with basalt: it was very carefully analysed by Dr Mitchell; unfortunately I have not been able to avail myself of the result of his researches, as he has left no account of his experiments.

Geognostic Situation.

According to Werner, it belongs exclusively to the floetz trap formation, where it occurs in beds which generally lie under basalt, and above clay*.

It

* Some German mineralogists mention wacce, as belonging to the primitive rocks, and have instanced several places in Silesia where

It is found also in veins, and generally forms the basis of amygdaloid.

It frequently contains imbedded crystals of mica and basaltic hornblende, but does not, like basalt, include augite or olivine.

Geographic Situation.

In Saxony, it is found at Scheibenberg, Annaberg, Wiefenthal, Joachimsthal, and Schlackenwalde; in Bohemia, at Bilin; and at Kinnekulle, and Norberg in Westmannland in Sweden.

Observations.

1. It is considered by Werner as intermediate between basalt and clay. When basalt contains mica, it is passing to wacce, because mica is nearly characteristic of wacce.

2. Near Joachimsthal, there is an immense rent filled with wacce, in which whole trees are found imbedded.

3. Many of the fossils described by Karsten, Charpentier, Reufs, Ferber, and other mineralogists,

where such appearances are to be observed. I enjoyed the invaluable opportunity of examining these places along with Dr Mitchell, but we found in every instance that disintegrated greenstone had been confounded with wacce.

are the true wacce of Werner, others, however, are most evidently greenstone. Full illustrations on this subject will be given in the Geognosie.

4 The gray wacce of Werner which is an aggregate rock, composed of fragments of flinty slate, clay slate, and quartz, connected by a basis of clay slate, must not be confounded with this species.

TWENTY-EIGHTH SPECIES.

Clinkstone.

Klingstein.—*Werner*.

Porphirschiefer, *Fischer*, b. 2. f. 747.—Klingstein, *Emm.*
b. 3. f. 344.—Pierre sonante, *Broch.* t. 1. p. 437.
Klingstein, *Klap. Beit.* b. 3. f. 229

External Characters.

It is commonly dark greenish gray, which sometimes passes into yellowish and ash gray.

Always massive.

Cross fracture feebly glimmering, almost dull; the principal fracture strongly glimmering, passing into glistening.

Cross fracture, splintery, passing into conchoidal, and even; principal fracture, is more or less perfectly flaty.

Fragments indeterminately angular, mostly sharp edged: sometimes they are tabular.

In the great it occurs in irregular columnar and tabular distinct concretions.

Commonly translucent on the edges.

Hard and semi-hard.

Brittle.

Easily frangible.

Not particularly heavy.

Specific gravity.—2,575.—*Klaproth*.

When struck with a hammer, sounds like a piece of metal.

Chemical Character.

Melts easily, and gives a nearly colourless glass, whereas basalt gives a black glass.

Constituent Parts.

Silica	57,25
Alumina	23,50
Oxyd of iron	2,25
Manganese	0,25
Natron	8,10
Water	3,00
	<hr/>
	98,10

According to *Klaproth*.

Geognostic Situation.

According to Werner, it belongs to the floetz trap formation. It generally rests on basalt, which was to be expected from its more chemical nature. It has a great affinity to basalt, into which indeed it sometimes passes.

Geographic Situation.

It is found near Zittau in upper Lusatia; in the Bohemian Mittelgebirge, and many other places of that highly interesting country; in South America according to Humboldt, and in the inland of Lamash in the frith of Clyde, where it occurs in beautiful and large columnar distinct concretions.

Observations.

1. Very generally crystals of felspar are imbedded in it, and then it forms porphyry slate, a rock which is very different from porphyry, although it has been often confounded with it.

2. Dr Reufs, in his mineralogical description of Bohemia, mentions it as belonging to the primitive rocks; this assertion, however, is devoid of proof.

TWENTY-NINTH SPECIES.

Lava.

Lava.—*Werner*.

This species is by *Werner* divided into two sub-species. 1. Slag Lava. 2. Foam Lava.

FIRST SUBSPECIES.

Slag Lava.

Schlackige Lava.—*Werner*.

External Characters.

Its colour is greyish black, which passes into yellowish grey, greenish grey, and sometimes into greenish black.

It is externally spotted, reddish, yellowish brown, and grey; when the sulphureous vapour has acted

much on it, it is coloured yellowish white and sulphur yellow.

It occurs vesicular and knotty, and the vesicles are empty. Internally its lustre alternates from glimmering to glistening, and sometimes also shining.

Its fracture is imperfectly conchoidal, also fine grained uneven.

Is generally opaque, sometimes a little translucent on the edges.

Is semi-hard,

Brittle.

Easily frangible.

Not particularly heavy.

Observation.

It frequently incloses other fossils, as augite, hornblende, and leuzite, which, being more refractory, have escaped nearly unaltered.

SECOND SUBSPECIES.

Foam Lava.

Schaumige Lava.—*Werner*.*External Characters.*

Its colour is dark greenish grey, which approaches to greenish black.

It occurs sometimes small and fine vesicular, and also amorphous.

Externally its lustre is glimmering.

It is difficult to determine its fracture; *Werner* suspects that it is uneven.

Is slightly translucent on the edges.

It is intermediate between hard and semi-hard.

Brittle.

Easily frangible, often completely crumbling.

Light.

Observation.

Observations.

1. It has been very often confounded with pumice, from which it differs very much, as may be seen by comparing the descriptions given in this work.

2. Its particular geognostic characters will be given at full length in the Geognosie; at present I shall only mention one character, first observed by Werner, which sufficiently distinguishes it from unaltered rocks. When lava contains crystals of hornblende, augite, or leuzite, they are wrapped up, not imbedded in its basis; and, when they occur in vesicles or air holes, one part of the crystal projects into the cavity, and the other is included in the lava, and does not therefore, as is the case with zeolite or other fossils formed by infiltration, &c. fill the air holes, form druses, or only cover the sides.

3. It is the opinion of many mineralogists that lava should not find a place in a system of Oryctognosie, but for what reason I have never been able to learn. Werner considers it as entitled to its present place, because it is mechanically simple.

Use.

On account of its lightness it is employed for building, particularly for arching vaults. The rock out of which the famous millstones of Andernach are cut

cut does not belong to this species, although it has been asserted by several mineralogists, but to the floetz trap rocks.

Observation.

Hauy, in his Treatise on Mineralogy, enumerates the following species of lava: 1. Basaltic lava. 2. Petrofiliceous lava. 3. Felspathic lava. 4. Amphigenous lava. 5. Vitreous lava, comprehending obsidian, pearlstone, and pumice. 6. Scoriaceous lava. Of all these the only true lava is the last mentioned; the others, as will be shewn in the Geognosie, are natural unaltered rocks.

THIRTIETH SPECIES.

Green Earth*.

Grünerde.—*Werner*.Green earth, *Kirw.* vol. 1. p. 196. *Emm.* t. 1. p. 353.—La terre verte, *Broch.* t. 1. p. 445.*External Characters.*

Its colour is seldom green of various degrees of intensity, which passes into mountain and blackish green, seldom approaches to leek and olive green.

It occurs sometimes massive, sometimes in angular, also in globular and amygdaloidal shaped pieces, also disseminated, or as a crust lining the vesicles or air holes of amygdaloid, or covering agate balls.

Internally it is dull.

Fracture even, sometimes fine earthy, sometimes passing into flat conchoidal.

Fragments indeterminately angular blunt-edged.

Streak glistening.

* This and the following species connect the Clay and Talc Genera together.

Very soft.

Mild.

Easily frangible.

Light.

Geognostic Situation.

It is found principally in amygdaloid, in which it occurs in balls, crusts, and amygdaloidal shaped pieces. Dr Reufs, in the third volume of his Mineralogy of Bohemia, describes beds of it, that appear to belong to the floetz trap formation.

Geographic Situation.

It is found in Saxony, Bohemia, Monte Baldo near Verona, Scotland, and wherever amygdaloid occurs.

Use.

It is used by painters.

53	Silica	516
28	Oxide of Iron	THIRTY.
2	Magnesia	1
10	Potash	18

THIRTY-FIRST SPECIES:

Lithomarge.

Steinmark.—*Werner*.

Id. Wid. p. 434.—Lithomarga, *Kirw.* vol. 1. p. 187.—
 Litomarga, *Nap.* p. 259.—Steinmark, *Emm.* t. 1. p.
 355 —La Moelle de Pierre ou la Lithomarge, *Broch.*
 t. 1. p. 447.

Werner divides this species into two subspecies.
 1. Friable Lithomarge. 2. Indurated Lithomarge.

FIRST SUBSPECIES.

Friable Lithomarge, or Rockmarrow.

Zerreibliches Steinmark.—*Werner*.

External Characters.

Its colours are snow white, yellowish white, and feldom reddish white.

Is usually massive, occurs also as a crust, and dif-feminated.

Its lustre is feebly glimmering.

Is generally coherent, also sometimes loose, and is composed of fine scaly particles that approach to dusty.

Feels greasy.

Adheres to the tongue.

Geognostic Situation.

Found in considerable quantity in the Saxon tin veins.

SECOND SUBSPECIES.

Indurated Lithomarge, or Rockmarrow.

Festes Steinmark.—*Werner*.

External Characters.

It is most commonly white, of which it presents the following varieties: yellowish, snow, and reddish white; also pearl grey, plumb blue, lavender blue; further, flesh red and ochre yellow.

The white and red are uniform, but the other colours are usually disposed in clouded and spotted delineations*.

Is massive.

Internally it is dull.

Fracture large conchoidal, passing into even and fine earthy.

* The Wonder earth, or terra miraculosa, which is a variety of this subspecies, is remarkable for the beauty of its colour delineations.

- Fragments indeterminately angular, not particularly sharp edged.
- Streak shining.
- Very soft.
- Perfectly mild.
- Easily frangible.
- Adheres strongly to the tongue.
- Feels greasy.
- Is light.

Geognostic Situation.

It occurs in veins of porphyry, gneiss, and serpentine; in drusy cavities in topaz rock, or nidular in basalt, amygdaloid, and serpentine; and in beds over coal.

Geographic Situation.

Found in Saxony at Ehrenfriederdsdorf, Altenberg, Marienberg, Rochlitz, where the flesh red variety occurs in porphyry, Planitz *, where it lies over coal; in Bohemia, Bavaria, and the Harz.

* The variety called Wonder earth is found at Planitz.

Observation.

Observation.

It passes on the one side into steatite, and probably also meerschaum, and on the other into variegated clay.

THIRTY-SECOND SPECIES.

Rock Soap.

Bergseife.—*Werner*.

Id. Cronst. p. 189. *Id. Wid.* p. 436. *Emm. t. i.* p. 360.—

Le favon de montagne, *Broch. t. i.* p. 453.

External Characters.

Its colour is pitch or brownish black.

Is massive and disseminated.

Dull.

Fracture fine earthy.

Fragments indeterminately angular, blunt edged.

Opaque.

Does not foil.

Writes as well, if not better, than drawing slate.

Streak shining and resinous.

Very soft.

Completely mild.

Easily

Easily frangible.

Adheres strongly to the tongue.

Is not particularly heavy, nearly light.

It has much resemblance to indurated lithomarge.

Geognostic and Geographic Situations.

Found imbedded in rocks belonging to the floetz trap formation. It is very rare, and has been hitherto found only at Olkutfch in Poland, and in the Island of Skye in Scotland,

Use.

If it could be procured in quantity it would form a most excellent material for the painter.

THIRTY-THIRD SPECIES.

Yellow Earth.

Gelberde.—*Werner*.

Id. Wid. p. 427.—Yellow earth, *Kirw.* vol. 1. p. 194.

Emm. t. 1. p. 362.—La terre jaune, t. p. 455.

External Character.

Its colour is ochre yellow of various degrees of intensity.

Is massive.

The lustre of its principal fracture is feebly glimmering, cross fracture dull.

Principal fracture more or less perfectly flaty, cross fracture earthy.

Fragments partly indeterminately angular, blunt edged, partly tabular.

Streak somewhat shining.

It foils.

Writes.

Is very soft, passing into friable.

Adheres pretty strongly to the tongue.

Feels a little greasy.

Light.

Geognostic and Geographic Situations.

It occurs in beds, along with iron stone, in the flötz clay formation, at Wehraw in Upper Saxony.

Use.

It is employed as a yellow pigment.

F I F T H G E N U S .

TALC GENUS.

F I R S T S P E C I E S .

Bole.

Bohl.—*Werner*.

Bole, *Kirw.* p. 191. *Id. Estner*, b. 2. f. 784. *Id. Emm.* b. 1. f. 381.—Bole, *Nap.* p. 256.—Le Bol, *Broch.* t. 1. p. 459.

External Characters.

Its colour is cream yellow, which, by reason of the red in its composition, passes on the one side into flesh red, on the other into light yellowish brown, and then into a colour which is intermediate between chestnut brown and brownish black. Sometimes it is spotted brown and black.

It is commonly massive, seldom disseminated.

Internally its lustre is glimmering.

Fracture perfectly conchoidal.

Fragments indeterminately angular sharp edged.

The red variety is semi-transparent, the yellow translucent on the edges, the dark opaque.

Very soft.

Mild.

Easily frangible.

Feels greasy.

Gives a shining streak.

Adheres to the tongue.

Light.

Specific gravity.—1.400 to 2,000, *Kirwan*.

When dry and put into water, it breaks with an audible crackling noise.

Chemical Characters.

Before the blow pipe it melts without addition into a greenish grey coloured clay, according to Wiedemann.

Constituent Parts.

Magnesia	6,2
Silica	47,0
Alumina	21,0
Lime	5,4
Iron	5,4
Water	17,0

 102

Bergman Opuscul Chem. t. 4. p. 152.

Geognostic Situation.

It occurs in rocks belonging to the newest floetz trap formation.

Geographic Situation.

It is found in beds of wacce at Strigau in Silesia, and in basalt at Scheibenberg in Saxony; in Italy it is found at Sienna and Toscana, and in the Island of Lemnos in the Hellespontic Archipelago.

Use.

Use.

It was formerly used as a medicine, now it is only employed as a pigment.

Observation.

It is distinguished from Lithomarge by colour, lustre, transparency, and falling to pieces in water,

SECOND SPECIES.

Native Talc Earth.

Helvin oder Natürliche Talkerde.—*Werner*.

Magnésie Native, *Broch.* t. 2. p. 499—.

External Characters.

Its colour is yellowish grey, passing into cream yellow. It is marked with blackish brown coloured spots, and with similar coloured dendritic delineations.

Occurs massive, tuberosé, and of shape which is intermediate between vesicular and perforated; and the walls of the cells are rough and uneven.

Internally it is dull.

Fracture in the great pretty large and flat conchoidal, in the small, splintery.

Fragments more or less sharp edged.

Almost opaque.

Soft, passing to very soft.

Not very mild.

Not

Not particularly difficultly frangible.

Feels a little meagre.

Adheres a little to the tongue.

Not particularly heavy, approaching to light.

Constituent Parts.

According to the analysis of Dr Mitchell and Professor Lampadius it affords carbonic acid 0,510, magnesia 0,474, and a trace of iron, *Lampad. Samml. Practisch. Chem. abhandl. b. 3.*

Geognostic Situation.

It is found in serpentine rocks accompanied with meerschaum.

Geographic Situation.

Has been hitherto found only at Robschütz in Moravia.

Observations.

1. Werner, from its external characters, places it between bole and meerschaum.

2. We are indebted to Dr Mitchell for our knowledge of this fossil. He found it during his travels in
in

in Austria, and on his return to Freyberg presented it to Werner, who drew up the preceding description, and gave it its present place in the system.

THIRD SPECIES.

Meerschaum:

Meerschaum.—*Werner.*

Id. Wid. f. 456.—Keffekil, *Kirw.* vol 1. p. 144.—Meerschaum, *Emm.* b. 1. f. 378.—Schiuma di mare, *Nap.* p. 307.—Variété de talc, *Lam.* p. 342.—L'écume de mer, *Broch.* t. 1. p. 462.

External Characters.

Its colour is yellowish white, which approaches to yellowish grey; it is very rarely snow white.

Occurs massive.

Internally it is dull.

Fracture fine earthy, passing into flat conchoidal; or is sometimes large conchoidal in the great, and fine earthy in the small.

Fragments indeterminately angular, pretty sharp edged.

Opaque.

Streak shining.

Soft, passing into very soft.

Mild.

Not particularly easily frangible.

Adheres strongly to the tongue.

Feels a little greasy.

Light, and nearly swimming.

Specific gravity—1,600, according to *Klaproth*.

Chemical Characters.

Before the blow pipe it is infusible without addition.

Constituent Parts.

Silica	54,16	From 58,50	to 41,00
Magnesia	51,66	17,25	18,25
Lime		0,50	0,50
Water		2,50	} 39,00
Carbonic acid		5,00	
	<hr/>	<hr/>	<hr/>
	105,82	98,25	98,75
	<i>Wiegleb.</i>	<i>Klaproth.</i>	b. 2. f. 172.

Geognostic Situation.

It is said to occur in some places in beds.

Geographic Situation.

It is principally found in Natolia, in Lesser Asia; and the island of Samos; also in Greece, Hungary, Robschütz in Moravia; at Valecas near Madrid in Spain; in small quantities in Thuringia; and in some parts of the continent of America.

Use.

It is principally used for the manufacture of the heads of tobacco pipes, and the quantity employed for that purpose is very great. It is said that the Turks eat it, when spread on bread, as a medicine, and cover the head and eyes of dead bodies with it, before burial. As it absorbs oily matter it is used by the Tartars for cleansing.

Observations.

1. It is sufficiently distinguished from native talc earth by its colours, greater softness, and less specific gravity;

gravity; from lithomarga, by its not possessing the same suite of colours, and its less specific gravity; from bole, by its colours, want of lustre, and transparency.

2. It is said to be very soft in its repository, but when exposed to the air becomes harder.

3. It is named Meerschaum, from its great lightness, and its being sometimes found in the neighbourhood of the sea.

4. The Tartarian name Keffikil which Mr Kirwan assumes as the name of this species, is said to have been imposed on it by the Turks, because the Tartars name it Kila.

5. The substance of which the Indian tobacco-pipes are made is not known to mineralogists.

6. Strabo and Pliny mention floating bricks, and lately Mr Fabroni has been able to form similar ones, from a fossil substance, which is found near Castel del Piano near Sienna. Mr Brochant suspects that it may be meerschaum.

FOURTH SPECIES.

Fullers Earth.

Walkererde.—*Werner*.

Id. Wid. p. 429.—Fuller's earth, *Kirw.* vol. 1. p. 184.—Walkererde, *Esfner*, b. 2. f. 777. *Id. Emm.* b. 1. f. 375.—Terra da follone, *Nap.* p. 258.—La Terra a Foulon, *Broch.* t. 1. p. 464.

External Characters.

Its colours are greenish white, greenish grey, olive and oil green.

Some varieties exhibit spotted and striped colour delineations.

Massive.

Internally it is dull.

Fracture sometimes uneven, sometimes passing into large conchoidal, seldom splintery; in some varieties fine earthy, and sometimes shews a tendency to fine flaty.

Fragments indeterminately angular, blunt edged; also flaty.

Usually opaque.

Gives

Gives a shining streak.

Very soft, passing into friable.

Mild.

Adheres scarce perceptibly to the tongue.

Feels greasy.

Not particularly heavy.

Sometimes it is coloured and mixed with iron ochre, but this is to be considered as accidental.

Chemical Character.

It melts into a brown spongy scoria; it falls to pieces in water without forming a paste with it, or without foaming like soap, as is asserted by some authors.

Constituent Parts.

Hampshire fullers earth affords

Silica	51,8
Alumina	25,0
Lime	3,3
Magnesia	0,7
Iron	0,7
Water	15,5

Bergman. Opuscul. t. 4. p. 156.

Geognostic Situation.

At Roffwein in Upper Saxony, it is found under strata of greenstone slate, consequently it there belongs to the primitive rocks. In England, where the finest fullers earth is found, it is still problematical whether it occurs in alluvial land, or in one of the newer flötz formations, or in both.

Geographic Situation.

Found in Hampshire and Bedfordshire in England; at Rofswein and in Voightl and in Saxony; at Rittenau in Alface; and Osmundburg in Sweden.

Use.

It is used for cleansing woollen cloth, which is effected by an operation called fulling, whence the name fullers earth.

Observations.

Werner suspects that the fullers earth of Roffwein in Saxony is formed by the decomposition of greenstone slate, as it is there covered by it, and we can trace the gradation from fully-formed fullers earth to fresh

fresh greenstone. May it not in this case rather be considered as an original deposition of greenstone in a loose state of aggregation, resembling the disintegrated felspar in certain beds of gneiss, &c. ?

FIFTH SPECIES.

Nephrite.

Nephrit.—*Werner*.

This species is by Werner divided into two subspecies. 1. Common Nephrite. 2. Axe stone.

FIRST SUBSPECIES.

Common Nephrite.

Gemeiner Nephrite.—*Werner*.

External Characters.

Its colour is leek green, of various degrees of intensity, and sometimes passes into greenish white.

Occurs massive, in blunt edged pieces, and rolled pieces.

Generally dull; sometimes it exhibits a silver white glimmer, which is caused by intermixed fibres of talc and asbest

Fracture coarse splintery, and the splinters greenish white.

Fragments indeterminately angular, not remarkably sharp edged.

Translucent.

Hard.

Difficultly frangible.

Feels a little greasy.

A little brittle.

Not remarkably heavy.

Constituent Parts:

What is called the nephrite of Switzerland, according to Hoepnfer affords,

Silica	47,0
Magnesia	38,0
Alumina	4,0
Lime	2,0
Oxyd of Iron	9,0

Geognostic Situation

Is not known ; probably occurs in serpentine.

Geographic Situation.

It is found on the banks of the river of Amazons, in South America ; in China and the East Indies ; and it is said to have been found in several parts of Europe, as in the dutchy of Austria, Moravia, Tyrol, Switzerland and Savoy.

Use.

It is difficult to saw and cut, and although it takes a good polish it has still an oily and muddy aspect. Its great tenacity, however, enables the artist to execute

cute on it beautifully delicate figures, without the risk of breaking. The Turks cut it into handles for sabres and daggers, which they prize very much; and the Indians make talismans of it.

Observations.

1. It was long believed to be a remedy for alleviating, or even curing and preventing nephritic complaints, hence it was called Nephritic stone.

2. In India it is named Igida, from whence the Abbé Estner conjectures is derived the French word Jade.

SECOND SUBSPECIES.

Axestone.

Beilstein — *Werner*.

Id. Estner, b. 2. f. 851. *Id. Emm.* b. 3. f. 351. — La
Pierre de Hache, *Broch.* t. 1. p. 470.

External Characters.

Its colour is intermediate between mountain green and leek green, and passes into dark grass green, oil green and greenish grey.

Occurs massive.

Internally its lustre is strongly glimmering.

Fracture flaty in the great, and more or less distinctly splintery in the small.

Fragments tabular.

Translucent.

Semi-hard, approaching to hard.

Not particularly brittle.

Difficultly frangible.

Not particularly heavy.

Geognostic Situation.

Occurs in beds in the newer primitive mountains, particularly in clay slate?

Geographic Situation.

Australasia, in New Zealand; several of the islands of Polynesia; Europe, in Saxony, Carpathian Alps, Switzerland, Corfica; Asia, in China.

Use.

It is used by the natives of New Zealand, and several of the islands of Polynesia, for hatchets and other offensive weapons.

Observations.

It approaches to indurated talc, particularly the Saxon varieties.

SIXTH SPECIES.

Steatite.

Speckstein.—*Werner*.

Creta hispanica, *Wall.* t. 1. p. 396.—*Creta brianfonia*, *Wall.* t. 1. p. 390.—Speckstein, *Wid.* f. 451.—Semindurated Steatite, *Kirw.* vol. 1. p. 151.—Speckstein, *Efner.* b. 2. f. 791.—*Id.* *Emm.* b. f. 363.—Steatite compatta, *Nap.* p. 296.—Steatite, *Lam.* t. 2. p. 343.—La Steatite commune, *Broch.* t. 1. p. 474.

External Characters.

Its principal colour is white, of which it presents the following varieties: greyish, greenish, seldom yellowish, and reddish white: the reddish borders on flesh red: the greenish white passes into mountain, oil, and lastly into fishkin green.

Sometimes it shews dendritic and spotted delineations.

It occurs massive, disseminated, in crusts, and crystallised.

The crystals are six-sided prisms, acuminate on both extremities by six planes, that are set on the lateral planes. The crystals are very rare.

The

The lateral planes are transversely streaked, but the acuminating planes are smooth.

They are middle sized, small, and are imbedded in the massive.

Internally it is dull, or accidentally glimmering.

Fracture coarse splintery, in many varieties uneven, in others conchoidal, and in some rare varieties we observe a tendency to coarse fibrous.

Fragments undeterminately angular, blunt edged.

Commonly translucent on the edges, seldom faintly translucent.

Streak shining.

Very soft and soft.

Perfectly mild.

Rather difficultly frangible.

Does not adhere to the tongue.

Feels greasy.

Is not particularly heavy.

Specific gravity.—Steatite of Bareuth, 2,614. according to Blumenbach.

Chemical Characters.

Before the blow pipe, it loses its colour, and becomes hard, but is infusible without addition.

Constituent Parts.

	Steatite of Cornwall.		Of Bareuth.
Silica	48,0	59,50	58,33
Magnesia	20,50	30,50	39,16
Oxyd of iron	1,0	2,50	2,50
Water	15,50	5,50	0,0
Alumina	14,0	0,	0,
	<hr/>	<hr/>	<hr/>
	99,0	98,0	99,99
	<i>Klap. t. 2. p. 177.</i>	<i>t. 2. p. 180.</i>	<i>Weigleb.</i>

Geognostic Situation.

It occurs in beds and veins in serpentine; also in irregular shaped pieces, imbedded in rocks, (particularly wacce,) belonging to the floetz trap formation.

Geographic Situation.

It is found in Norway, Sweden, Saxony, Bohemia, Principality of Bareuth, France, England, particularly at Cape Lizard, Scotland, at Portfoyl, where it traverses serpentine in form of veins, and in the island of Skye, where it is imbedded in wacce. It is also found in China.

Use.

The cornish is used for the manufacture of porcelain; other varieties are said to be used for fulling, and the Chinese work it into vessels of various shapes.

Observations.

The yellowish white variety, approaches to lithomarge, the flesh red to bole, and the finkin green and greenish grey, to fullers earth.

Sometimes green by the action of sulphuric acid paper is to be used

Regener's Hand

SEVENTH SPECIES.

Serpentine.

Serpentin.—*Werner.*

This species is by Werner divided into two subspecies, 1. Common serpentine, 2. Precious serpentine.

FIRST SUBSPECIES:

Common Serpentine.

Gemeiner Serpentin.—*Werner*.

Id. Esner. b. 2. f. 855.—Talcum serpentinus vulgaris, *Id.*
Emm. b. 3. f. 276.—La serpentine commune, *Broch.* t. 1.
 p. 481.

External Characters.

Its principal colour is green, of which it presents the following varieties; leek, oil, and olive green; from oil green it passes into mountain green and greenish grey; from leek green it passes into greenish black; from greenish black, it passes into blackish green: sometimes it occurs yellow, and rarely yellowish brown; further red, of which it presents the following varieties: blood red, brownish red, peach blossom red, and scarlet red.

The peach blossom, and scarlet red colours are the rarest.

The colour is seldom uniform, there are generally several colours together, and these are arranged in striped, dotted, and clouded delineations.

It occurs massive.

Internally it is faintly glimmering, which passes in-

to dull, when there are no foreign particles to give a slight degree of lustre.

Fracture is sometimes splintery, sometimes large and flat conchoidal, also small grained, uneven, passing into even.

Fragments are indeterminately angular, not particularly sharp edged.

Faintly translucent on the edges.

Soft.

Not particularly brittle, passing into mild.

Not very difficultly frangible.

Feels a little greasy.

Not particularly heavy.

Chemical Character.

Before the blow pipe, it is infusible without addition.

Constituent Parts.

Magnesia	23,0	33,50	35,0
Silica	45,0	45,00	41,0
Alumina	18,0		10,0
Iron	3,0		3,0
Iron and a trace of al.		14,00	
Lime		6,25	
Water	12,0		

Kirwan.

Knoch. Chem. Ann. Bayer.

1790. 2. f. 504.

Geognostic

Handwritten notes at the bottom of the page, partially illegible.

Geognostic Situation.

It is one of the primitive rocks. Werner describes two formations, one, which is the oldest, occurs in the oldest clay slate, and is accompanied with limestone; the other, which is considerably newer, is supposed to be disposed in overlaying stratification over the older primitive rocks. The oldest generally contains the precious serpentine; thus intimating a more complete solution than that of the newer formation. The newer is not accompanied with limestone, but contains imbedded pyrope, magnetic iron stone, steatite, and affords the common serpentine.

Geographic Situation.

It is found in Saxony, as at Zöblitz, (this is the newer formation,) Waldheim, Hohenstein, Limbach, Chemnitz; in Bohemia, Silesia, Corfica, Italy, Siberia, England, as in Cornwall; (probably the newer formation;) Scotland, at Portfooy, (the older formation,) and in the Shetland islands, (probably the newer formation).

Use.

As it is soft and takes a good polish, it is turned into vessels and ornaments of a great variety of shapes.

At

At Zöblitz in Upper Saxony, several hundred people are employed in quarrying, cutting, turning, and polishing the serpentine, which occurs in that neighbourhood, and the various articles into which it is manufactured are carried all over Germany. The serpentine of Portsoy is far superior to that of Zöblitz in colour, hardness, and transparency, and when cut is very beautiful.

SECOND SUBSPECIES.

Precious Serpentine.

Edler Serpentin.—*Werner*.

Esner. b. 2. f. 859.—*Id. Emn.* t. 3. f. 276.—La serpentine noble, *Broch.* t. 1. p. 484.

This subspecies is by *Werner* divided into two kinds: *a.* Conchoidal precious serpentine; *b.* Splintery precious serpentine.

a. Conchoidal precious serpentine.

External Characters.

Its colour is dark leek green, passing into blackish green; and it sometimes, although seldom, approaches to pistacio green.

Occurs massive, and disseminated.

Internally its lustre is glistening, sometimes passing into glimmering, and is resinous.

Fracture conchoidal.

Fragments

Fragments indeterminately angular, very sharp edged.

Translucent.

Not particularly brittle.

Feels rather greasy.

Not particularly heavy.

Soft, and semi-hard.

Geographic Situation.

It is found in Silesia.

Observation.

The verde antico is a variety belonging to this kind, *verde antico - greenish white*

δ. Splintery Precious Serpentine.

External Characters.

Its colour is nearly the same with the preceding.

Massive.

Fracture splintery.

Fragments indeterminately angular, but not so

Geographic

sharp edged as those of the conchoidal kind; in other characters it agrees with the preceding.

Geographic Situation.

It is brought from Italy, where it is named Nephrite. It is also found, but sparingly, in Saxony; also at Reichenstein in Silesia, where it is accompanied with amianth, granular lime-stone, or goldish pyrites.

EIGHTH SPECIES.

Schiller Stone.

Schillerstein.—Werner.

External Characters.

Its colour is olive green.

Usually disseminated and massive, probably also crystallized.

Lustre shining, passing into semi-metallic.

Fracture perfectly foliated, single cleavage.

Sometimes

Sometimes unseparated, sometimes in large and coarse grained distinct concretions.

Soft.

Slightly brittle.

Easily frangible.

Not particularly heavy.

Geognostic Situation.

It occurs imbedded in serpentine, and is frequently accompanied with mica.

Werner is of opinion that it bears the same relation to serpentine, that calc-spar does to lime-stone, or selenite to foliated gypsum, and may, therefore, perhaps, be considered as crystallized serpentine..

Geographic Situation.

It is found at Basta in the Harz, at Zöblitz in Saxony; Mr Hatchett discovered it in Cornwall, and I have it from Ayrshire.

Observation.

It has been, and by many mineralogists is still confounded with labrador hornblende, from which, as

we have already learnt, it differs both in geognostic and oryctognostic characters.

NINTH SPECIES.

Talc.

Talk.

This species is by Werner divided into three sub-species: 1. Earthy talc: 2 Common talc: 3 Indurated talc.

FIRST SUBSPECIES.

Earthy Talc.

Erdiger Talc.—*Werner*.

Id. Wid. f. 439.—Talcite, *Kirw.* p. 1. 149.—Erdiger talc,
Estner, b. 1. f. 821.—*Emm.* b. 1. f. 389.—Talcio terroso,
Nap. p. 295.—Le talc terreux, *Broch.* t. p. 486.

External Characters.

Its colour is intermediate between greenish white
 and light greenish grey.

Friable.

Strongly glimmering, bordering on glistening.

It is composed of glimmering pearly small scaly
 parts.

Soils a little.

Feels rather greasy.

Light.

Geognostic Situation.

Occurs in tin veins.

Geographic

Geographic Situation.

Found near Freyberg in Saxony.

Observation.

It must not be confounded with Schaum or foaming earth.

SECOND SUBSPECIES.

Common or Venetian Talc.

Gemeiner Talc.—*Werner*.

Gemeiner talc, *Wid.* p. 441.—Common talc, or Venetian talc, *Kirw.* vol. 1. p. 150.—Gemeiner talc, *Efner*, b. 2. f. 824.—*Id.* *Emm.* b. 1. f. 391.—Talc compatto, *Nap.* p. 293.—Talc ecailleux.—*Lam.* t. 2. p. 342.—Talc laminaire.—*Hauy* Le talc commun, *Broch.* t. 1. p. 487.

External Characters.

Its principal colour is apple green, which passes on one side into greenish white, and even into silver white, on the other into asparagus green, and rarely into emerald green?

Is massive, and disseminated, and in extremely delicate and small tabular crystals, which are sometimes collected in druses.

It is almost always splendid and shining, and internally it is pearly or semi-metallic; (the white varieties possess the semi-metallic lustre).

Fracture straight, and curved foliated, often also undulatingly foliated, as is the case with mica.

Fragments

Fragments wedge shaped, seldom splintery.

Cleavage single.

Translucent, but transparent in thin leaves.

It occurs in large, coarse, small, and fine grained distinct concretions, but more frequently unseparated.

Flexible, but not elastic.

Véry soft.

Perfectly mild.

Easily frangible.

Feels very greasy.

Is not particularly heavy, approaching to light.

Chemical Character.

It is infusible before the blow pipe without addition, a character which distinguishes it from chlorite.

Brochant.

Constituent Parts

Magnesia	44,00
Silex	50,00
Alumina	6,00

According to *Hæpfner*, *Helv. Mag.* iv. s. 296.

Geognostic Situation.

It is almost entirely confined to the primitive mountains, where it occurs in beds, imbedded in serpentine, and also in veins.

Geographic Situation.

Very beautiful specimens are found in the Tyrolese Alps, and the mountains of Switzerland and Salzburg; also in Saxony, at Ehrenfriedersdorf, and Zöblitz.

Observation.

It is frequently confounded with mica, from which, however, it is distinguished by want of elasticity, greasy feel, and colour.

THIRD SUBSPECIES.

Indurated Talc.

Verhærteter Talk.—*Werner*.

Id. Eßner, b. 2. f. 828. *Id. Emm.* b. 3. f. 280.—Le talc
endurci, *Broch.* t. 1. p. 489.

External Characters.

Its colour is greenish grey, of various degrees of intensity.

Occurs massive.

Lustre shining passing to glistening, and is pearly.

Fracture intermediate between imperfectly foliated and curved flaty; some varieties even pass into promiscuously fibrous and rayed.

Fragments flaty.

Strongly translucent on the edges, sometimes passing into translucent.

Soft, approaching to very soft.

Perfectly mild.

Not particularly difficultly frangible.

Feels rather greasy.

Not particularly heavy.

Constituent

Constituent Parts.

Magnesia	38,54
Silica	38,12
Alumina	6,66
Lime	0,41
Iron	15,02

Wiegleb. Hæpfn. Helv. Magazin. iii. f. 166.

Geognostic Situation.

It occurs in primitive mountains, where it forms beds in clay slate, and serpentine, and is accompanied with chlorite and asbest.

Geographic Situation.

It is found in the Tyrol, Austria, Stiria, Switzerland; Scotland, in Breadalbane, and the Shetland islands.

Observations.

It has a very strong resemblance to potstone, with which it has been often confounded.

TENTH SPECIES.

Asbest.

Asbest.—*Werner*.

Werner divides this species into the following sub-species, 1. Rock cork. 2. Amianth. 3. Common asbest. 4. Rock wood.

FIRST SUBSPECIES.

Rock Cork.

Berg Kork.—*Werner*.

Aluta montana, *Wall.* t. 1. p. 414.—*Suber montanum*, *Id.* p. 415.—Bergkork, *Wid.* f. 469.—*Suber montanum*, *corium montanum*, *Kirw.* vol. 1. p. 163.—Bergkork *Efner*, b. 2. f. 864. *Id. Emm.* b. 1. f. 399.—Sughero montano, *Nap.* p. 319.—Variété d'amiante, *Lam.* p. 367.—La siege de montagne, *Broch.* t. 1. p. 492.

External Characters.

Its most common colour is yellowish grey, of various degrees of intensity, which passes into yellowish white, greyish white, and pale ash grey; it is also sometimes yellowish brown, and cream yellow.

Seldom presents ochre yellow spots.

Occurs sometimes massive, sometimes in plates and with impressions*.

Lustre feebly glimmering, sometimes nearly dull.

* The plate-shaped variety is named rock leather, and rock flesh.

Observation.

On one side it (by reason of its fibrous fracture), borders on amianth, on the other on meerschaum.

SECOND SUBSPECIES.

Amianth.

Amianth.—*Werner.*

Asbestos matorus. *Wall.* t. 1. p. 410.—*Amianthus, Id.* p. 408.—*Amianth, Wid.* f. 464. *Id. Kirw.* vol. 1. p. 161. *Efner.* b. 2. f. 368. *Id. Emm.* b. 1. f. 402.—*Amiantho, Nap.* p. 316.—*Lam.* t. 2. p. 365.—*L'amianthe Broch.* t. 1. p. 494.

External Characters.

Its most common colour is greenish white, of different degrees of intensity, passing into greenish grey and light olive green; sometimes blood red, particularly when it occurs venigenous in serpentine.

Generally

Generally massive, also in plates and small veins that traverse serpentine, and in capillary crystals.

Internally its lustre is glistening passing to shining; also sometimes splendid and pearly, approaching to silky.

Fracture very delicately parallelly fibrous, and sometimes a little curved.

Fragments thin splintery.

Sometimes faintly translucent, sometimes only translucent on the edges.

Very soft.

Mild.

Intermediate between common and elastically flexible.

Splits easily.

Difficultly frangible.

Light, approaching to not particularly heavy.

Chemical Characters.

It is difficultly fusible before the blow pipe.

Constituent Parts.

	A. of Swarlich.	A. of Tarentaise.	A. of Corias in Spain.
Silica	64,0	64,0	7,20
Magnesia	17,2	18,6	12,9
Alumina	2,7	3,3	13,3
Lime	13,9	6,9	10,5
Barytes		6,0	
Iron	2,2	1,2	2,2
	—	—	—
	100	100	99,19

According to *Bergman*.

It has been lately analysed by *Chenevix*, who obtained the following result.

Silica	59,0
Magnesia	25,0
Lime	9, $\frac{1}{4}$
Alumina	3,0
Iron	2, $\frac{1}{4}$
Lofs	1, $\frac{1}{4}$
	—
	100

Patrin's Mineralogie, and Nouveau Dictionnaire
D'Histoire Naturelle, t. 1. p. 309.

Geognostic Situation.

It is found in primitive rocks, and particularly in serpentine in which it occurs usually in veins. *See*

Geographic Situations.

It is found in Sweden, Bohemia, Silesia, Italy, Hungary, Siberia, France, Spain, and Scotland, as at Inveraray, Portsoy, and isle of Unst one of the Shetlands*.

Uses.

From its flexibility, and its resisting the effects of fire, it is said to have been, by the ancients, wove into a kind of cloth, in which they wrapped the bodies of persons of distinction before they were placed on the funeral pile, that their ashes might be collected free from admixture; it was also used for incom-bustible wicks, but it is now considered only as an object of curiosity.

* Mineralogy of the Scottish isles.

THIRD SUBSPECIES.

Common Asbest.

Gemeiner Asbest.—*Werner*.

Asbestus immaturus, *Wall.* t. 1. p. 411.—Gemeiner asbest, *Wid.* p. 471.—Asbestus, *Kirw.* vol. 1. p. 159.—Gemeiner asbest, *Efner*, b. 2. f. 872. *Id. Emm.* b. 1. f. 406.
 --Asbesto commune, *Nap* p. 314.—Asbeste, *Lam.* t. 2. p. 369.—Asbeste dur, *Haüy*.—L'Asbeste commune, *Koch.* t. 1. p. 497.

External Characters.

Its colours are dark leek green, and mountain green, sometimes also greenish grey, and greenish grey passing into olive green.

It occurs massive and in capillary crystals.

Internally its lustre is glistening and pearly.

Fracture parallelly radiated, and coarsely, parallelly, and curved fibrous*.

* Patrin, in his Natural History of Minerals, describes and figures a fossil by the name Abeste Rayonnant, which, however, is only a variety of actynolite. The fibrous diverging fracture shews that it does not belong to asbest.

Fragments splintery.

Commonly translucent, at least on the edges.

Soft, verging on semi hard.

Not particularly brittle.

Rather difficultly frangible.

Not flexible; some varieties shew an incipient flexibility.

Feels rather greasy.

Not particularly heavy.

Specific gravity 2.000.

Chemical Characters.

Before the blow pipe it melts very difficultly into a greyish black coloured scoria.

Constituent Parts.

Silica 46,66

Magnesia 48,45

Iron 4,79

Wiegleb Chem. Ann. 1784, b. 1. f. 521.

Geognostic Situation.

Is the same as amianth.

Geographic Situation.

Is found in Sweden, Hungary, Dauphiny, Uralian Mountains, and Scotland.

Observations.

1. It stands in the same relation to amianth, as indurated does to common talc.
2. Some varieties approach to indurated talc, others to amianth.

FOURTH. SUBSPECIES.

Rock Wood. ✓

Bergholz.—Werner.

Id. Wid. f. 473.—Ligniform asbestus, *Kirw.* vol. 1, p. 161.
 —Bergholz, *Estner*, b. 2. f. 877. *Id. Emm.* b. 1. f. 410.
 Legno montano, *Nap.* p. 321.—Asbeste ligniforme,
Hauy, t. 3. p. 240.—Le bois de montagne, *Broch.* t. 1.
 p. 499.

External Characters.

Its colour is wood brown of various degrees of intensity.

Occurs massive, and in plates.

Internally its lustre is glimmering.

Fracture in the great curved foliated, in the small delicately and promiscuous fibrous.

Fragments flaty.

Streak more shining than its lustre.

Soft, passing into very soft.

Mild.

Rather difficultly frangible.

A little elastically flexible.

Feels meagre.

Light.

Geognostic

+ This is a more mineral
 form

Geognostic and Geographic Situations.

It occurs principally in the Tyrol, where it is found in primitive mountains along with amianth.

General Observations on the Species.

The different subspecies of this species generally occur in the same geognostic situations, only the rock cork is found in mineral veins. They are usually found in serpentine.

B. talc.

ELEVENTH SPECIES.

Kyanite, or Cyanite.

Cyanit, oder Kyanit.—*Werner.*

Sappare, Sauff. f. 1900. & *J. de Phy.* 1789, p. 213.—
Cyanite, *Wid.* f. 475. *Id. Kirw.* vol. 1. p. 209. *Id.*
Estner, b. 2. f. 690. *Emm.* b. 1. p. 412. *Id. Nap.* p. 328.
—Cyanite, *Lam.* t. 2. p. 256.—*Difstene, Hauy*, t. 3. p.
220.—*La Cyanite, Broch.* t. 1. p. 501.

External Characters.

Its principal colour is blue, and of this the following varieties occur: smalt blue, berlin blue, sky blue, and this latter borders on feladon green. It occurs also milk white, blueish grey, and pearl grey.

Many specimens are entirely blue, others are only spotted, striped, or flamed with it.

It occurs massive, disseminated, and crystallised in long and broad, a little oblique, four-sided prisms, which are truncated on the lateral edges.

They are either imbedded or intersect one another, and are middle sized, small, and very small.

Externally

Externally and internally its lustre is shining and splendid, and is completely pearly.

Its fracture is very broad, diverging, promiscuous, a little curved radiated, and sometimes passes into curved foliated.

The fracture of the crystals is foliated, and presents a three fold cleavage, in which the folia intersect each other obliquely, and under unequal angles; but of these only one cleavage is distinct.

Fragments flaty, splintery, wedge-shaped, and sometimes imperfectly rhomboidal.

It occurs in wedge-shaped distinct concretions, which are often very promiscuous, and then pass into large and coarse grained distinct concretions.

Usually translucent, and the crystals often transparent.

Soft.

Not particularly brittle, approaching to mild.

Has a slight degree of flexibility.

Easily frangible.

Feels a little greasy?

Not particularly heavy, approaching to heavy.

Specific gravity.—3,517, *Saussure the younger*.—3,622, *Hermann*.

Chemical Character.

Before the blow pipe it is infusible without addition.

Constituent

Constituent Parts.

Silica	29,2	to	30,62
Alumina	55,0		54,5
Lime	2,25		2,02
Magnesia	2,0		2,3
Oxyd of iron	6,65		6,0
Water and loss	4,9		4,56
	<hr/>		<hr/>
	100,0		100,0

According to *Saussure the younger*.

Geognostic Situation.

It is peculiar to the primitive mountains, where it occurs imbedded in talc slate, and mica slate, accompanied with grenatite.

Geographic Situation.

It is found in Norway; in Scotland, in Aberdeenshire near Banchory, and in the Mairland, the largest of the Shetland islands*; France, Bavaria, Alps of Switzerland, particularly in Mount St. Gothard, Salzburg, the Tyrol, Carinthia, Pyrenees, and in Siberia.

* Mineralogy of the Scottish isles.

Andersson's paper in 3 N America Observations.

Observations.

1. It is the link which connects talc with actynolite and tremolite.

2. The blue colour does not occur in any other talcy fossil; it is therefore characteristic of kyanite.

3. It was at first arranged in the flint genus, along with the species schorl; as soon, however, as Werner had an opportunity of examining it, he found that it was essentially different from schorl, and constituted a distinct species, which by its natural characters proved to be a species of the talc genus.

4. Its name is derived from the blue colour which so remarkably characterises it.

5. Varieties which have a fine berlin blue colour and considerable transparency, are cut and sold as sapphire.

6. The very pale varieties are sold for tremolite, but the slight tinge of blue which always accompanies the palest, is a mark which distinguishes it from tremolite. In doubtful cases the geognostic character is of assistance: tremolite occurs usually in limestone, but kyanite in talc or mica slate.

Faint handwritten notes, possibly describing the properties or uses of the mineral, including mentions of 'Berlin blue' and 'sapphire'.

FIRST SUBSPECIES.

Asbestous Actynolite.

Asbestartiger Strahlstein.—*Werner*.

Id. Wid. f. 479.—Amianthinite, and Metalliform Asbestoid, *Kirw.* vol. 1. p. 164. & 167.—Asbestartiger Strahlstein, *Emm.* b. 1. f. 416.—Asbestoide, *Lam.* t. 2. p. 371.—Actinote, *Haüy*.—La Rayonnante Asbestiforme, *Broch.* t. 1. p. 504.

External Characters.

Its colour is greenish grey, which passes on the one side through mountain green into smalt blue, on the other through olive green into yellowish and liver brown. In some varieties it approaches to black. The blue variety is very rare.

It occurs massive, disseminated, and in capillary crystals.

The crystals are sometimes elastically flexible.

Internally its lustre is glistening and pearly or rather silky.

Its fracture is intermediate between fibrous and narrow radiated; the latter is longitudinally streaked, also straight, scopiform, and stellular.

Fragments

Fragments wedge shaped.

It occurs in coarse and wedge shaped prismatic distinct concretions.

It is from translucent on the edges to opaque.

Soft and very soft.

Brittle.

Rather difficultly frangible.

Not particularly heavy.

Specific gravity—2,584, *Raschau*.—2,916, *Bareuth*.

Chemical Characters.

Before the blow pipe it is fusible without addition into a black or grey coloured scoria.

Geographic and Geognoetic Situations.

It occurs in mineral beds at Raschau near Schwarzenberg in Saxony, Bareuth, and Bannat of Temeswar. That of Bareuth is said to occur in serpentine.

SECOND SUBSPECIES.

Common Actynolite.

Gemeiner Strahlstein.—*Werner*.

Id. Wid. f. 480.—Schorlaceous actynolite, and common asbestoid, *Kirw.* vol. 1. p. 168. and 166.—Gemeiner Strahlstein, *Esner.* b. 2. f. 887.—*Id. Emm.* b. 1. f. 418.—Stralite commune, *Nap.* p. 323.—Zillerthite, *Lam.* t. 2. p. 357.—Actinote hexaedre, *Hauy*, t. 3. p. 74.—La Rayonnante commune, *Broch.* t. 1. p. p. 507.

External Characters.

Its principal colour is leek green, from which it passes on the one side through pistacio green *, olive green, into liver brown? on the other into mountain green? and blackish green.

It occurs massive and crystallised, in very oblique rhomboidal six-sided prisms, in which the two opposite lateral edges are obtuse, and the terminal angles truncated; or we may consider it as a very

* The pistacio green variety is almost always crystallised, and *Werner* suspects that it may prove a distinct species. It is the Thallite of the French Mineralogists.

oblique

oblique rhomboidal four-sided prism, having its acute lateral edges truncated.

The crystals are long, often acicular, and imbedded. The lateral planes are smooth, and often longitudinally streaked.

Externally it is splendent, internally shining, and intermediate between vitreous and pearly.

Fracture most commonly radiated, from very small to pretty broad radiated, almost always scopiformly, and diverging radiated, seldom parallel; sometimes it is foliated, with an indistinct two fold cleavage.

Fragments sometimes wedge shaped and splintery, sometimes indeterminately angular, blunt edged.

It occurs in wedge-shaped prismatic concretions, also in large, coarse, and small grained distinct concretions.

The massive is intermediate between translucent, and translucent on the edges, and sometimes even verges on transparent. Crystals transparent.

Semi-hard in a high degree.

Pretty brittle.

Pretty difficultly frangible.

Not particularly heavy, approaching to heavy.

Specific gravity, from 3,000, to 3,310. *Kirwan.*

Chemical Characters.

It is fusible without addition, into a blackish scoria according to Wiedenman, but according to Lelievre into a grayish black enamel.

Constituent

Constituent Parts.

Silica	64,0
Magnesia	20,0
Alumina	2,7
Lime	9,3
Iron	4,0
	—
	100,0

Bergman Opusc. t. 4. p. 172.

Geognostic Situation.

The massive variety occurs in beds, in primitive mountains, accompanied with different species of ore, as lead glance, magnetic iron stone, and iron pyrites. The crystallised varieties are found in granular limestone, talc slate, and in veins of the oldest formation.

Geographic Situation.

Saxony, as at Ehrenfriedersdorf, Gieshübel, Tyrol, Salzburg, Switzerland, Piemont, Norway, and Scotland, as in Glenelg, opposite the island of Skye, and Fula, the most remote of the Scottish isles*.

* Mineralogy of the Scottish isles.

Observation.

The green schorl of Romé d'Isle, the delphinite of Sauffure, the thallite of La Metherie, the epidote of Hauy, appear to be only varieties of this sub-species.

THIRD SUBSPECIES.

Glassy Actynolite.

Glasartiger Strahlstein.—*Werner*.

Id. Wid. f. 483.—Glassy actynolite, *Kirw.* vol. 1. p. 168.
 —Glasartiger Strahlstein, *Estner*, b. 2. f. 893.—*Id. Emm.*
 b. 1. f. 422.—Stralite vetrofa, *Nap.* p. 326.—La Rayon-
 nante vitreuse, *Broch.* t. p. 510.

External Characters.

Its principal colour is mountain green of various degrees of intensity, which passes on the one side into greenish grey and greenish white, on the other into emerald green, and dark grass green?

Occurs massive, or in thin six sided acicular crystals.

Lustre shining, and vitreous.

Fracture delicately and coarsely promiscuous fibrous, and narrow, scopiformly diverging radiated, seldom parallelly radiated.

Fragments

Fragments splintery and wedge shaped.

Thick prismatic distinct concretions, inclose smaller ones of the same kind.

Strongly translucent.

Brittle.

Easily frangible.

Has cross rents.

Semi-hard, approaching to soft.

Not particularly heavy.

Specific gravity according to *Kirwan*, is from 2,950, to 3,903.

Its geognostic and geographic situations are nearly the same as the preceding subspecies.

Observation.

The fossils of this species appear to pass into hornblende, asbest, and tremolite. Thus asbestous actynolite seems to pass into amianth, the blackish green variety of common actynolite appears to be intermediate between actynolite and hornblende, as is shown by its colours, lustre and hardness; and the greenish white variety of glassy actynolite, verges on glassy tremolite.

THIRTEENTH SPECIES.

Tremolite.

Tremolith.—*Werner*.

Werner divides this species into three subspecies,
 1. Asbestous Tremolite. 2. Common Tremolite.
 3. Glassy Tremolite.

FIRST SUBSPECIES.

Asbestous Tremolite.

Asbestartiger Tremolith.—*Werner*.

Id. Emm. b. 1. f. 425. *Id. Estner*, b. 2. f. 893.—La Tremolith asbestiforme, *Broch.* t. 1. p. 514.

External Characters.

Its colours are yellowish white, also greyish white, reddish white, and greenish white.

Internally

Occurs massive, and in capillary and acicular crystals.

Internally its lustre is glistening, sometimes bordering on glimmering, sometimes passing to shining, and is pearly.

Fracture most generally delicately, straight, and scopiformly diverging fibrous.

Fragments splintery and wedge shaped.

Occurs in distinct concretions, which are wedge-shaped prismatic, passing into granular, and are promiscuous.

Only translucent on the edges, but approaches to translucent, when it borders on the following subspecies.

Very soft.

Easily frangible.

Mild.

Not particularly heavy.

SECOND SUBSPECIES.

Common Tremolite.

Gemeiner Tremolith.—*Werner*.

Id. Esner, b. 2. f. 901. *Id. Emm.* h. 1. f. 426.—Grammatite, *Haüy?*—La tremolithe commune, *Broch.* t. 1. p. 515.

External Characters.

Its colours are greyish, greenish, yellowish and reddish white. The greenish white passes into pale asparagus green; and the greyish white into dark smoke grey. It probably also occurs bluish grey? when verging on kyanite.

Occurs sometimes massive, sometimes in long and very oblique four-sided prisms, in which the obtuse lateral edges are sometimes rounded off so that the crystal has a reed-like aspect; sometimes they are bevelled, and the bevelling planes are set on the acute lateral edges; and sometimes the lateral edges are truncated.

The crystals are middle sized, longitudinally streaked, promiscuously aggregated, and are imbedded.

Occurs

Internally its lustre is shining and glistening, and is pearly.

Fracture sometimes broad radiated, sometimes foliated; both are streaked, and the foliated appears to have a two fold longitudinally intersecting cleavage, whence the fracture has a longitudinally streaked surface. The radiated is promiscuous and scopiformly radiated.

Cross fracture uneven.

Fragments indeterminately angular, and approach sometimes to the cubical.

The massive occurs in large and coarse grained distinct concretions, which sometimes approach to the wedge-shaped prismatic.

Translucent, but the crystallized semi-transparent.

Semi-hard.

Pretty easily frangible.

Not particularly heavy.

THIRD SUBSPECIES.

Glassy Tremolite.

Glasartiger Tremolith.—*Werner*.

Id. Ffner, b. 2. f. 907. *Id. Emm.* b. 1. f. 429.—La Tremolithe vitreuse, *Broch*, t. 1. p. 516.

External Characters.

Its colours are yellowish, reddish, greyish and greenish white.

Occurs massive and crystallized.

Internally its lustre is shining, passing to glistening, and is pearly.

Fracture very narrow radiated, which sometimes inclines to scopiformly diverging, and sometimes approaches to fibrous.

It has parallel oblique cross rents, resembling schorlous beryll.

Fragments most usually splintery.

It is composed of very thin prismatic concretions, which are again collected into very thick prismatic concretions. The latter are rather wedge-shaped, and are promiscuous.

Translucent.

Soft

Very easily frangible.

Brittle.

Not particularly heavy.

Chemical Characters.

Before the blow pipe it melts without addition into a cellular white coloured scoria.

Constituent Parts.

Silica	65,00
Magnesia	10,33
Lime	18,00
Oxyd of iron	0,16
Water and carbonic acid	6,50

99,99

Klaproth.

Physical Character.

Said to emit a phosphoric light when rubbed in the dark, which property is denied by Count de Bournon.

Geognostic Situation.

It is found principally in primitive mountains, and is there usually imbedded in limestone. It has been also found in rocks belonging to the floetz trap formation, accompanied with prehnite.

Geographic Situation.

It has been hitherto found in the greatest beauty and quantity in the mountains of Tremola, in the vicinity of St Gothard in Switzerland; also in Transylvania; the Tyrol; Carinthia; Bannat of Temeswar; Moravia; in the limestone quarries of Langenfeld in the electorate of Saxony; in the Shetland islands, near Beith in Ayrshire, and in the basaltic rock on which the castle of Edinburgh is built.

Observation.

Actynolite and tremolite are nearly allied; one of the most characteristic distinctions is the green colour, which is characteristic of actynolite, but is rare and only very faint in tremolite. Werner remarks that tremolite is related to actynolite in the same manner as leuzite is to garnet.

SIXTH GENUS.

CALC GENUS.

FIRST SPECIES.

Rock Milk.

Bergmilch — *Werner*.

Agaricus mineralis, *Wall.* t. 1. p. 30.—Bergmilch, *Wid.* p. 490.—Agaric mineral, *Kirw.* vol. 1. p. 76.—Bergmilch, *Estner*, b. 2. f. 914. *Id. Emm.* b. 1. f. 430.—Agaric mineral, *Nap.* p. 333. *Id. Lam.* p. 333.—Lait de montagne ou l'agaric mineral, *Broch.* t. 1. p. 519.—Chaux carbonatée spongieuse, *Hauy*.

External Characters.

Its colour is yellowish white, which sometimes approaches to snow white and greyish white.

Composed of dull dusty particles, which are almost always weakly cohering.

Feels meagre, yet fine.

Soils very much,

Light, nearly swimming:

Chemical Characters.

It effervesces powerfully with acids, and is also completely dissolved in it. It is a compound of calcareous earth and carbonic acid.

Geognostic and Geographic Situations.

It is found in fissures and holes of mountains composed of floetz limestone, and principally in Switzerland.

Observation.

It appears to be formed by meteoric water passing over limestone rocks, and afterwards depositing, in holes and fissures, the calcareous earth which it had dissolved in its course.

SECOND SPECIES.

Chalk.

Kreide.—*Werner*.

Creta alba, *Wall.* t. 1. p. 27.—Kreide, *Wid.* f. 491.—
Chalk, *Kirw.* vol. 1. p. 77.—Kreide, *Estner*, b. 2.
f. 917. *Id. Emm.* b. 1. f. 433.—Creta commune, *Nap.*
p. 331.—La craiè, *Broch.* t. 1. p. 521.

External Characters.

Its colour is yellowish white, which sometimes also approaches to snow white and greyish white.

It is sometimes marked with yellowish brown spots.

Occurs massive, disseminated, and as crust covering flint.

Internally it is dull.

Fracture pretty fine earthy.

Fragments indeterminately angular, blunt edged.

Opaque.

Soils.

Writes.

Very soft, and often passes into friable.

Feels

Rather mild.

Very easily frangible.

Feels meagre, and rather rough.

Light.

Specific gravity.—2,315, *Kirwan*.—2,657, *Watson*.—
2,252, *Muscshenbroeck*.

Chemical Character.

It effervesces strongly with acids. It is composed almost entirely of lime and carbonic acid.

Geognostic Situation.

It constitutes a peculiar kind of formation, which is probably one of the newest belonging to the floetz limestone. It contains numerous flinty petrefactions, which are principally glossopetræ, echinites, pectinites, and chamites. It is also remarkable for being the most general repository of flint, which occurs either disseminated, in tuberosè-shaped masses, or in beds that alternate with it.

Geographic Situation.

It is found principally on sea coasts, as at Calais and Dover, and several of the Danish islands in the Baltic, as Rugen and Seeland. It occurs also in Poland,

land, and several great tracts of contry in the south of England are composed of it.

Use.

It is principally used for polishing and cleansing metals, glafs, &c. also for white crayons,

THIRD SPECIES.

Limestone.

Kalkstein.—*Werner*.

Werner divides this species into the following subspecies: 1. Compact limestone. 2. Foliated limestone. 3. Fibrous limestone. 4. Peastone.

FIRST SUBSPECIES.

Compact Limestone.

Dichter Kalkstein.—*Werner*.

Of this species there are two kinds, *a*. Common compact limestone. *b*. Roe stone.

a. Common

a. Common Compact Limestone.

Gemeiner Dichter Kalkstein.—*Werner*.

Calcareus æquabilis, *Wall.* t. 1. p. 122.—Dichter Kalkstein, *Wid.* p. 494. Compact limestone, *Kirw.* vol. 1. p. 82.—Gemeiner dichter kalkstein, *Emm.* b. 1. f. 437.—*Pietra calcarea compacta*, *Nap.* p. 33.—*La pierre calcaire compacte commune*, *Broch.* t. 1. p. 523.

External Characters.

Its most common colour is grey, of which the following varieties have been observed: yellowish, bluish, ash and smoke grey. The ash grey passes into greyish black, the yellowish grey into yellowish brown, and into a colour bordering on cream yellow, and into ochre yellow. It also occurs blood, flesh, and peach blossom red, but this latter colour is very rare.

It frequently exhibits veined, zoned, striped, clouded, and spotted colour delineations; it sometimes also presents on the rents brown and black coloured arborizations*.

* A very beautiful ash grey variety, which is found in Carinthia, shews a pearly variegated play of colours, whence it is called opalescent marble.

It occurs most commonly massive, also in rolled pieces, in a variety of extraneous external shapes, and in large tables (as that of Pappenheim).

Internally it is dull.

Fracture small and fine splintery, which passes sometimes into large and flat conchoidal, sometimes into uneven, which approaches to earthy. One variety has a tendency to the flaty fracture.

Fragments indeterminately angular, more or less sharp edged.

Translucent on the edges.

Semi-hard.

Brittle.

Pretty easily frangible.

Not particularly heavy.

Specific gravity.—From 2,600 to 2,700.

Constituent Parts.

It is principally composed of lime and carbonic acid, and a small portion of iron, alumina, and inflammable matter.

Geognostic Situation.

This fossil constitutes several very distinct and highly characteristic formations, concerning which a full detail will be given in the Geognosie, at present

sent I shall only remark, that it is almost entirely confined to the floetz mountains.

Geographic Situation.

It occurs in the sandstone and coal formations of Saxony, Bohemia, Bavaria, Sweden, France, England, Scotland, &c.

Use.

It is frequently used for building and the making of roads. When by burning it is deprived of its water and carbonic acid, it is used for mortar, and in this state it is also employed by the soap-maker, the tanner, and the farmer; it is also very often used as a flux, in the reduction of such ores as are difficultly fusible, by reason of an intermixture of silica and alumina.

The florentine arborescent marble, which is a variety of this kind, is valued for ornamental purposes; and the limestone of Pappenheim, when it rises in thick tables, serves for paving stones, grave stones, and because it does not alter its shape, it is sometimes employed in the polishing of plate glass for mirrors.

Observation.

The bluish grey variety often passes into marle.

b. Roestone.

Roogenstein.—*Werner.*

St lactites—Oolithus, var. *b. c. d.* *Wall.* t. 2. p. 384.—
Roogenstein, *Wid f* 511.—Oviform limestone, *Kirw.*
vol. 1. p. 91.—Roogenstein, *Estner*, b. 2. f. 928.—
Id. Emm b. 1. f. 442.—Tufo oolitico, *Nap.* p. 353.—
L'oolite, *Brock.* t. 1. p. 529.

External Characters.

Its colour is hair brown and chestnut brown, but the considerable quantity of marle which it contains makes it yellowish grey and ash grey.

Is massive.

Internally dull.

Fracture fine splintery, but it is very difficult to observe, on account of the smallness of the distinct concretions.

The

The fragments in the large are indeterminately angular and very blunt edged.

It is composed of small and fine grained globular distinct concretions; the small grained include or are composed of fine grained concretions, which are composed of concentric lamellar concretions, as in the pea stone.

Opaque, or at the utmost only translucent on the edges.

Semi-hard.

Brittle.

Very easily frangible.

Not particularly heavy.

Geognostic Situation.

It occurs in beds, which are interposed between strata of sand stone, that belong to the second sand stone formation.

Geographic Situation.

It is found in considerable quantity in the province of Thuringia in Saxony. as at Eisleben, Arterm, Sangerhausen, Klosteroda, &c.

Use.

Use.

It is used as a manure, but on account of its easy disintegration, it is never employed for building, and its marly nature renders it unfit for mortar.

Observation.

It was for a long time considered to be an aggregation of petrified fish roes, and afterwards it was, by many mineralogists, described as a conglomerate, formed by the union of rolled pieces of limestone by a marly cement. It is scarcely necessary to say that these opinions are completely erroneous, and that the structure of this fossil is owing to crystallization.

SECOND SUBSPECIES.

Foliated Limestone.

Blättriger Kalkstein.—*Werner*.

This subspecies is by Werner divided into two kinds. *a.* Granular limestone. *b.* Calc spar.

a. Foliated

a. Granular Limestone,

Körniger Kalkstein.—*Werner*.

Calcareus micans, *Wall.* t. 1. p. 126.—*Calcareus inequalis*, *Id.* p. 128.—*Marmor unicolor album*, *Id.* p. 133.—*Körniger kalkstein*, *Wid.* f. 496.—Foliated and granular limestone, *Kirw.* vol. 1. p. 84.—*Körniger kalkstein*, *Esner*, b. 2. f. 931. *Id. Emm.* b. 1. f. 445.—*Pierre calcaire grenue*, *Broch.* t. 1. p. 531.

External Characters.

Its most common colour is white, of which it presents the following varieties: snow white, yellowish white, greyish white, and greenish white, seldom reddish white. From greyish white it passes into bluish, greenish, ash, and smoke grey, and from the smoke grey into greyish black. From the reddish white it passes into pearl grey and flesh red, and from yellowish white into cream yellow. From greenish white it passes into siskin and olive green.

It is generally uniform, seldom marked with spotted and clouded delineations.

Massive.

Internally it alternates from shining to glistening and glimmering, some varieties even approach to splendid,

splendent, and is intermediate between pearly and vitreous.

Fracture foliated, and sometimes, on account of the fineness of the grains, it appears splintery.

Fragments indeterminately angular blunt edged.

It occurs almost always in granular distinct concretions, which are coarse, small, and fine grained; the latter passes into compact, and sometimes is only distinguished by its glimmering.

Almost always more or less translucent, and the black variety is only translucent on the edges.

Semi-hard.

Brittle.

Easily frangible.

Not particularly heavy.

Specific gravity—2,700 to 2,800.

Chemical Character.

It usually effervesces with acids, and is purer than common limestone.

Geognostic Situation.

It is peculiar to the primitive and transition mountains, and occurs but rarely, and only in single beds in the floetz formations. The oldest granular limestone in which the concretions are very distinct, occurs in gneiss; but in the newer, which is found in

the transition rocks, the concretions are scarcely visible. The interesting conclusions which Werner has drawn from this fact will be detailed in the *Geognosie*.

It has frequently other fossils imbedded in it, and of these the following occur most frequently: mica, hornblende, actynolite, asbest, quartz, serpentine, lead glance, blende, iron pyrites, and magnetic iron stone.

Geographic Situation.

The snow white variety is found peculiarly beautiful at Carrava in Italy, where it is quarried, and from thence distributed over Europe for the purposes of statuary. The white marble of Paros in the Hellespentic Archipelago, has been long celebrated on account of its fitness for sculpture and other useful and ornamental purposes. The architectonic marbles are generally marked with various colour delineations, and are suspected by Werner to belong principally to the transition rocks. They are found in the Harz, and in other countries where transition rocks occur.

In Scotland we have several marbles or granular limestones, which are remarkable for their beauty. Of these, the marble of Tiree is the most noted; and next in consideration are those of Sutherland, Port-foy, and Island of Skye*.

* Mineralogy of the Scottish isles.

Use.

It is employed for the same purposes as common compact limestone, but on account of its granular fracture, its higher degree of transparency, and its greater variety and beauty of colour, it has also, from time immemorial, been used by the statuary and architect.

The history of all the varieties of marbles, with the account of their individual uses, value, &c. will be given in the volumes of this work that treat of Oeconomical Mineralogy.

Observation.

Tournefort, in his voyage to the Levant, informs us that M. Lauthier, secretary to the King of France, had in his possession a flexible sandstone; since that time, similar varieties have been imported from Brazil; and more lately, M. Fleuvian de Belvue has discovered varieties of granular limestone that possess, in an eminent degree, the same property. He has succeeded in rendering common granular limestone and granular quartz completely flexible, by exposing them to a certain degree of heat.

b. Calc spar.

Kalkspath.—*Werner*.

Spathum, *Wall.* t. 1. p. 140. — Variety of körniger kalkstein, *Wid.* f. 427. — Common spar, *Kirw.* vol. 1. p. 86. — Kalkspath, *Efner.* b. 2. f. 941. *Id. Emm.* b. 1. f. 455. — Spatho calcareo, *Nap.* p. 341. — Calcaire cristallisé, *Lam.* t. 1. p. 29. — Chaux carbonatée cristallifiée, *Haüy.* t. 2. p. 127. — Le spath, calcaire, *Broch.* t. 1. p. 536. — Calcareous spar of British mineralogists.

External Characters.

Its principal colour is white; it occurs also frequently grey, green, seldom yellow, and very seldom rose red, and pale violet blue. The most common varieties of white are greyish, yellowish and greenish white, also reddish white, but that is rare; the varieties of green are olive, asparagus, pistacio, and leek green, which latter passes into greenish grey.

From yellowish white it passes into wax and honey yellow, which sometimes approach to wine yellow, and pass into yellowish grey.

From reddish white it passes into pearl grey, even into light violet blue, but the red and blue appear to be accidental varieties.

On the surface of the crystallized varieties (we must except grey and red), a play of colours is to be observed. The prismatic varieties are usually yellow, and of all the colours the yellowish and greenish are the most characteristic.

Besides massive and disseminated, it occurs also in crusts, stalactitical, in globular and amygdaloidal shaped pieces, in druses, and kidney shaped; but it occurs most frequently crystallized, and presents a great variety of crystallizations.

It possesses three fundamental figures to which all its other crystallizations can be referred, these are the

1. Six-sided pyramid.
2. Six-sided prism, and
3. Three-sided pyramid.

1. *Six sided Pyramid.*

When perfect it is acute, and three alternate lateral edges are more obtuse than the others. It occurs,

1. Simple, and this is either erect or inverted.

The inverted has three cylindrical concave, and three inwardly bent lateral planes, and on the upper extremity it is flatly acuminated by three planes which are set on the cylindrically concave lateral planes.

2. Double, where the lateral planes of the one are obliquely set on the lateral planes of the other, in such a manner that the edges of the common

mon basis form a zigzag line, and the more obtuse lateral edges of the one are opposed to the less obtuse lateral edges of the other pyramid. Of this figure the following varieties occur :

- a. The extremity of the pyramid is sometimes more or less deeply and flatly acuminate by three somewhat convex planes, which are set on the more obtuse lateral edges ?
- b. The angles of the common base are often more or less deeply truncated. When the truncating planes become so large that they touch one another, the transition into the six-sided prism is formed.
- c. The less obtuse edges are sometimes bevelled, and the extremities sometimes more or less deeply truncated.
- d. If two double six-sided pyramids penetrate one another in the direction of their axis, and one of them is turned around a sixth of its periphery, so that the less obtuse lateral edges of the one crystal come to be opposed to the less obtuse lateral edges of the other, the result is, a twin crystal, representing a double six-sided pyramid having three alternate re-entering angles at the common base, where the more obtuse lateral edges are opposed to one another,

2. *Six-sided Prism.*

It occurs usually with three alternate lateral planes broader than the others, and rather acutely acuminated by six planes which are set on the lateral edges, and the acuminating planes meet alternately under more obtuse angles.

- a. The same prism a second time flatly acuminated by three planes which are set on the alternate obtuse lateral edges of the first acumination.
- b. When the planes of the second acumination enlarge themselves so much that those of the first entirely disappear, thence results the six-sided prism flatly acuminated by three planes, which are set on the alternate and alternating lateral planes.
- c. The apex of the acumination is often more or less deeply truncated, which produces the six-sided prism in which the alternate and alternating terminal angles are truncated.
- d. When the truncation of the apex becomes so large that all traces of the acumination disappear, the perfect six-sided prism is formed.
- e. When the prism becomes lower, it passes into the six-sided table, which is often extremely thin.

3. *Three-*

3. *Three-sided Pyramid.*

1. Simple three-sided pyramid, whose summit angle is of all degrees of magnitude, from obtuse to acute.
2. If the angles of the preceding figure are so deeply truncated that the angles of the truncating planes meet each other, an octaedron is formed.
3. The pyramid is often double, in which case the lateral planes of the one pyramid are set on the lateral edges of the other. It presents the following varieties.
 - a. Flat double six-sided pyramid, which has sometimes convex lateral planes.
 - b. If a number of these flat or obtuse pyramids are piled on one another, there is formed a six-sided prism acuminated by three planes, which are set on the alternate and alternating lateral planes.
 - c. When this pyramid becomes very obtuse it gives rise to the lens.
 - d. When the summits of the pyramid become less obtuse, and approach to right angles, a figure differing but little from the cube is formed.
 - e. When the summits become still more acute, an acute double three-sided pyramid is formed.

f. The

- f.* The acute double three-sided pyramid is sometimes truncated on the lateral edges, sometimes bevilled; in the latter case, when the bevilling planes become so large that the original ones are very small, or even disappear, the result is, an acute double three-sided pyramid, having its plane length-wise divided, or it is a double six-sided pyramid.
- g.* If the summits of the double six-sided pyramid are deeply truncated, it gives rise to the six-sided table, having its terminal planes set on alternately in opposite directions.

The crystals are aggregated in a variety of shapes; thus the flat double pyramids are sometimes disposed in rows, globularly, or rose-like. The six-sided prisms are sometimes scalarwise, scopiformly and globularly aggregated.

The acute three-sided pyramids are sometimes hollow.

The lateral planes of the crystals are commonly smooth and shining and splendid; sometimes also glistening and dull.

Internally its lustre alternates from splendid and specularly splendid to shining and glistening, and is most commonly vitreous, which in some varieties inclines a little to resinous, in others to pearly. In general the intensity of the lustre corresponds with the transparency. It is sometimes pretty perfectly pearly on the surface.

Fracture almost always perfectly foliated, most commonly straight foliated, seldom spherically curved foliated. It shews a threefold cleavage. Sometimes has a concealed foliated fracture.

Fragments rhomboidal.

The massive occurs in very large and coarse grained distinct concretions, seldom small grained; also in thick and thin prismatic diverging and intersecting concretions, which are obliquely longitudinally streaked; also in wedge-shaped prismatic concretions, which are also deeply and obliquely streaked.

The massive varieties are translucent, and sometimes even transparent. Crystals transparent and semitransparent. The transparent varieties are also duplicating.

Semi-hard,

Brittle.

Very easily frangible.

Not particularly heavy.

Specific gravity.—2,700.

Constituent Parts.

It is composed of lime and carbonic acid in the proportion of 35 to 34 in the hundred. Its water of crystallization is very inconsiderable, being, according to Bergman, in the 100 parts.

Physical Character.

Many varieties of calc spar, as Mr Hatchett informs me, become phosphorescent when laid on burning coal. Hauy has made a similar observation.

Geognostic Situation.

It occurs venigenous in almost every rock, from granite to the newest floetz trap; it is even found in alluvial land. The veins are sometimes very new, but others are so old as to be nearly of cotemporaneous formation with the rocks in which they run. It also frequently lines drusy cavities.

Occurs in a great variety of mineral veins, and in many of them it characterises the formation.

Geographic Situation.

It is so universally distributed that an enumeration of its localities would be unnecessary in a work like the present; therefore I shall only mention, that many of its most beautiful and rare crystallizations are found in Derbyshire in England, in Ireland, Saxony, France and Spain; each country affording peculiar varieties, which no doubt, in many cases, correspond with the different mineral vein formations in the districts where they occur.

Observations

Observations.

1. Brochant remarks, that the Wernerian description of calc-spar is not sufficiently minute, and therefore he finds it necessary to subjoin the crystalometrical observations of Hauy. However amusing the minute measurements of Hauy may be, they are of little or no use to the oryctognost, they cannot therefore find a place in this work. The preceding description of calc spar, which I have drawn up according to the Wernerian method, will enable us not only to distinguish calc spar from all other fossils, but to know its most remarkable varieties.

2. Brochant informs us that the fine rhomboidal calc spar of Iceland is obtained by splitting double six sided pyramids.

3. The rhomboidal calc spar of Fontainbleau differs from the common varieties, by having an intermixture of sandy particles.

THIRD SUBSPECIES.

Fibrous Limestone.

This subspecies is divided into two kinds : *a.* Common fibrous limestone. *b.* Fibrous Limestone, or calc sinter.

a. Common Fibrous Limestone.

Gemeiner Fasriger Kalkstein.—*Werner.*

External Characters.

Its colours are greyish, reddish, and yellowish white.
Occurs massive.

Its lustre is glistening, and sometimes shining, and is pearly.

Fracture coarsely, delicately, straight, and parallelly fibrous, which sometimes borders on radiated.

Fragments splintery.

more

More or less translucent.

Semi-hard.

In its other characters it resembles the preceding subspecies.

Geognostic Situation.

Occurs only in small veins.

Observations.

1. It has a considerable resemblance to fibrous gypsum, from which it is distinguished, however, by its superior hardness, and sharper aspect.

2. It has been sometimes confounded with zeolite; but it is sufficiently distinguished from it by its inferior lustre, greater hardness and specific gravity, and its never occurring with a diverging fibrous fracture.

3. The fassin spar found in Derbyshire belongs to this kind.

*b. Calc Sinter.*Kalksinter.—*Werner.**External Characters.*

Its most common colour is white, of which it presents the following varieties: snow, greyish, greenish, and yellowish white. The yellowish white passes into wax and honey yellow, and yellowish brown. It occurs also fisken, pistacio, asparagus, mountain, and verdegriis green; which latter passes into sky blue. Sometimes it is flesh red, peach blossom red, and reddish brown.

The last mentioned varieties are rare, and receive their colour from the mineral substances that occur in the vein along with them: thus the peach-blossom red is derived from cobalt, the verdigris green from copper, the fisken green from nickel, and the flesh red from manganese.

The only colour delineation is the striped.

It occurs most commonly massive, also in many particular external shapes, as reniform, botroidal, tubular, and coralloidal, but more commonly stalactitic, and tuberose.

Its surface is either rough or druffy; and frequently branches are terminated by a crystal.

Internally

Internally its lustre is most commonly glimmering, sometimes passing to glistening, and is pearly.

Fracture straight, scopiformly, and stellularly diverging fibrous; and is from very delicately fibrous to coarse fibrous, which is nearly radiated.

Fragments sometimes indeterminately angular, seldom splintery and wedge-shaped.

It occurs most commonly in curved lamellar distinct concretions, which are bent in the direction of the external surface; in the stalactitic and tubular varieties it has cylindrical convex concretions. Sometimes, although rarely, we find it in large and coarse grained distinct concretions.

More or less translucent, and some varieties approach to semi-transparent.

Semi-hard, approaching to soft.

Brittle.

Easily frangible.

Not particularly heavy.

Geognostic Situation.

It is found stalactitic and tubular, also reniform, botroidal, and in crusts, that hang from, or cover the roofs, walls, and floors of caves, which are usually in limestone.

The beautiful coralloidal variety, the flos ferri of some mineralogists, is found in veins of sparry iron stone. From its peculiar external shape, and its occurrence in drusy cavities, I am inclined to believe it
ought

ought perhaps to be considered, either as a groupe of crystalline shoots, or as an aggregation of crystals, than as stalactitic.

M. Patrin, who is advantageously known by his mineralogical researches, adduces the flos ferri as an incontestible proof of the truth of the exploded opinion of the vegetation of stones.

Geographic Situation.

The Grotto of Antiparos, the Baumans Cave in the Harz, and the Balme in Switzerland, all afford striking instances of calc sinter. It would be tedious to give more instances of what occurs in almost every limestone country.

Uses.

When it occurs in large masses it is used by the statuary for many of the purposes of marble. The alabaster of the ancients, or what is called oriental alabaster, is calc sinter. It was brought from Arabia in considerable quantities, and used principally for the drapery of marble statues. It is still used by the Italians, and is named by them Marmo Alabastrino.

Observations.

1. Brochant informs us that certain varieties of it are so porous as to allow water to percolate, and are on that account employed as filtering stones.

2. Many of the great caves in limestone countries are formed by masses of limestone, irregularly heaped on one another, and connected by calc sinter.

*The stone is sometimes used for
building purposes.*

FOURTH SUBSPECIES.

Peastone.

Erbfenstein.—*Werner*.

La pierre de pois, ou la pisolite, *Broch. t. 1. p. 555.*

External Characters.

Its most common colour is yellowish white, which sometimes approaches to snow white; from yellowish white it passes into light yellowish brown.

Commonly massive, seldom reniform.

Internally it is dull.

Fracture, when it can be observed, even.

Fragments in the great indeterminately angular blunt edged.

It is composed of spherically round distinct concretions, which are coarse and small grained, and sometimes approach to fine grained; these are again composed of very thin and concentric curved lamellar concretions.

Opaque, or translucent on the edges.

Soft, approaching to very soft.

Not remarkably brittle.

Very easily frangible.

Not particularly heavy, approaching to light.

Geographic and Geognostic Situations.

It is found in great masses in the vicinity of the hot springs at Carlsbad in Bohemia. According to Werner it is formed in the following manner: Particles of sand appear to be raised in the water by means of air bubbles, and become covered with calcareous earth, which is deposited around them in lamellar concretions; at length the globular concretions thus formed acquire so much specific gravity that they fall down, and being agglutinated give rise to peastone. What renders this explanation very probable is the almost constant occurrence of particles of sand in the middle of the globular concretions. Sometimes, but that is a rare case, the interior of the concretions is filled with air.

FOURTH SPECIES.

Schaum Earth, or Foaming Earth.

Schaumerde.—*Werner*.

Id. Emm. b. i. f. 484.—Schaum Kalk, *Len.* 2. p. 392.—
Silvery Chalk, *Kirw.* vol. i. p. 78.—L'écume de terre,
Broch. t. i. p. 557.

External Characters.

It has a very light yellowish, nearly silver white colour, and sometimes approaches to greyish white.

Occurs massive and disseminated, also sometimes loose and composed of fine scaly particles, or intermediate between friable and loose.

Its lustre is intermediate between shining and glistening; the loose varieties are glimmering, and intermediate between semi-metallic and pearly, but incline more to the latter.

Generally

Fracture curved foliated, single cleavage, and passes into small scaly.

Fragments indeterminately angular, blunt edged.

Presents large, coarse, small, and fine grained distinct concretions.

Generally opaque.

Soils a little.

Very soft.

Mild.

Most generally completely friable.

Feels fine, but not greasy.

Creaks a little.

Light.

Chemical Characters and Constituent Parts.

It makes a very brisk effervescence with acids, and is dissolved in them. According to Wiegleb it is a compound of lime and carbonic acid.

Geognostic Situation.

It occurs in cavities of the oldest floetz limestone.

Observation.

Geographic Situation.

It is found in the neighbourhood of Gera in the forest of Thuringia ; also in the north of Ireland ?

Observation.

According to Werner it is very nearly allied to slate spar.

FIFTH SPECIES.

Slate Spar.

Schiefer Spath.—*Werner*.

Id. Wid. f. 513.—Argentine, *Kirw. vol. 1. p. 105?*—*Schisto spatho, Nap p. 355.*—*Schiffer spath, Lam. t. 1. p. 385.*—*Le spath schisteux ou le schiefer spath, Broch. t. 1. p. 558.*

External Characters.

Its colour is milk, greenish and reddish white.

Massive.

Lustre intermediate between shining and glistening, and is completely pearly.

Fracture pretty perfectly common curved foliated, approaching sometimes to straight flaty, sometimes to undulating flaty; cleavage is single.

Fragments flaty.

Exhibits sometimes a tendency to large, and coarse grained distinct concretions, seldom curved lamellar distinct concretions.

Translucent.

Soft.

Intermediate

Intermediate between mild and brittle.
Pretty easily frangible.
Not particularly heavy.

Constituent Parts.

Almost entirely composed of carbonate of lime.

Geognostic Situation.

It occurs in limestone beds in primitive mountains.

Geographic Situation.

It is found at Königberg in Norway; at Bergrun, near Schwartzenberg in Saxony, where it is accompanied with lead glance and brown blende; and in Cornwall.

SIXTH SPECIES.

Brown spar.

Braun spath.—*Werner*.

Spath perlé, *R. d. L.* t. 1. p. 605. — Braunspath, *Wid.* f. 515.—Sidero-calcite, *Kirw.* vol. 1. p. 105.—Braunspath, *Estner*, b. 2. f. 999. *Id. Emm.* b. 1. f. 79.—Bruni-
spato, *Nap.* p. 356.—Le spath brunissant on le braun-
spath, *Broch.* t. 1. p. 563.

Werner divides this species into two subspecies,

1. Foliated brown spar.
2. Fibrous brown spar.

FIRST SUBSPECIES.

Foliated brown spar.

Blättriger braunspath.—*Werner.*

External Characters.

Its principal colour is white and red. Of white it presents the following varieties, greyish, yellowish, but principally reddish white; from reddish white it passes into flesh red, rose red, and brownish red, and into brown. The yellowish white variety sometimes borders on yellow. Some varieties approach to pearl grey, others to black.

It is sometimes spotted, and this is most frequently the case with the red coloured varieties.

Occurs massive, disseminated, globular, with tabular impressions, and very often crystallized in curved and straight planed rhombs, and in spherical lenses; from these arise the following figures :

1. The flat double three-sided pyramid having convex lateral planes. It is sometimes hollow.
2. Acute double three-sided pyramid, which is again flatly acuminate by three planes.
3. An

3. Oblique angular six-sided pyramid, in which the alternate edges are obtuser than the others.

The lens occurs single or in rows.

Surface of the crystals usually drusy; the rhombs, however, are smooth.

Externally its lustre is shining; internally it alternates from shining to splendid, but more frequently glistening, and is always pearly.

Fracture very frequently straight, but most generally spherically curved foliated, and has a threefold obliquely intersecting cleavage like calc spar.

Fragments rhomboidal.

Occurs in granular distinct concretions of all degrees of magnitude, but seldom fine grained; also in straight lamellar concretions, which are very much grown together.

More or less translucent, passing into translucent on the edges; the crystals semitransparent*.

Semi-hard.

Not particularly brittle.

A little difficultly frangible.

Not particularly heavy, approaching to heavy.

It is heavier than calc spar, but lighter than heavy spar.

Specific gravity.—2,837.

* When the transparency is very considerable it passes into calc spar.

Chemical Character.

By exposure to the blow pipe it hardens, and becomes dark brownish black; it effervesces faintly with acids, if not previously pulverised.

Constituent Parts

Carbonate of lime	50
Oxyd of iron	22
———— Manganese	28
	————
	100

According to *Bergman*.

Geognostic Situation.

Occurs principally in veins, and is generally accompanied with calc spar, and sparry iron ore, and sometimes with different species of ore, as lead glance, blende, pyrites, native silver, and various ores of silver. In the mining field of Freyberg it is one of the principal vein stones, and is considered as indicating rich bursts of silver ore.

Geographic Situation.

It is found in the mines of Norway, England, the Harz, Sweden, Saxony, Swabia, France, and Hungary.

Observations.

1. It is distinguished from calc spar, with which it is often confounded by its particular suite of colours, less transparency, complete pearly lustre, greater hardness, and greater specific gravity.

2. The straight lamellar variety has been mistaken for lamellar heavy spar, from which, however, it is distinguished not only by its inferior weight, but also by the concretions being very intimately joined together, which is not the case with heavy spar.

3. On exposure to the air it changes to brown, and even verges on black, and the same effect is produced by heating; on this account it received the name of Brown spar.

SECOND SUBSPECIES.

Fibrous brown Spar.

Fafriger braunspath.—*Werner.*

External Characters.

Its colour is flesh red, passing into rose red.

Occurs massive.

Lustre glistening.

Fracture straight and diverging fibrous, generally rather coarsely fibrous.

Fragments splintery and wedge-shaped.

Presents indeterminately angular, sometimes large and coarse grained distinct concretions.

In other characters it resembles the preceding subspecies.

Geographic Situation.

It has been hitherto found only in Hungary and Transilvania.

SEVENTH SPECIES.

Rhomb-spar.

Rautenspath.—*Werner*.

Bitterspath, *Wid.* f. 518.—Cristallized muricalcite, *Kirw.* vol. 1. p. 92.—Bitterspath, *Emm.* b. 3. f. 353.—Spatho magnesiaco, *Nap.* p. 358. *Id. Lam.* t. 2. p. 347.—Chaux carbonate magnésiée, *Haüy*.—Le spath magnésien ou le bitterspath, *Broch.* t. 1. p. 560.

External Characters.

Its colours are greyish and yellowish white and yellowish grey, which latter sometimes passes into pea yellow.

Never massive, but always in regular middle sized rhombs.

Lustre splendid, and intermediate between vitreous and pearly.

Fracture straight foliated, and has a three-fold obliquely intersecting cleavage; cross fracture uneven, and imperfectly and flat conchoidal.

Generally intermediate between translucent and semi-transparent.

Semi-

Semi-hard.

Brittle.

Easily frangible.

Specific gravity.—2,480.

Chemical Character.

Before the blow pipe it is infusible without addition. It produces very little effervescence with acids, even when powdered.

Constituent Parts.

According to Klaproth, b. 1. f. 304, it affords,

	From the Tyrol.	From Sweden.
Carbonate of lime	52	73,0
Carbonate of magnesia	45	25,0
Oxyd of iron and manganese	3	2,25
	<hr/>	<hr/>
	100	100,25

Geognostic Situation.

Occurs imbedded in rocks that belong to the talc genus, such as chlorite and talc slate.

Geographic Situation.

It is found at Brienz in Switzerland ; in the mountains of the Tyrol and Salzburg ; and at Taberg in Wermeland in Sweden. It occurs also in chlorite rocks on the banks of Loch Lomond in Scotland.

Observations.

1. Brochant and other French mineralogists are of opinion that this species and brown spar, are merely accidental varieties of calc spar. That this opinion is unfounded must be evident to every one who comprehends fully the preceding Wernerian descriptions.

2. The yellowish variety approaches to sparry iron stone.

3. It is named rhomb spar from its crystallization ; its former name bitter-spar, intimated that it contained magnesian earth.

EIGHTH SPECIES.

Schaalstone.

Schaalstein.—*Werner.**External Characters.*

Its most common colour is greyish white, which sometimes passes into greenish and yellowish white, and reddish white.

Occurs massive.

The lustre of its principal fracture is shining and nearly pearly.

Principal fracture foliated, with a slight tendency to splintery, and coarse fibrous. Cleavage single, and rather imperfect.

Occurs in straight and thin lamellar distinct concretions, which are collected into other large and broad prismatic distinct concretions, that pass into long and coarse grained concretions. The position of the concretions is promiscuous.

Translucent.

Semihard in a pretty high degree.

Brittle.

Easily frangible.

Not particularly heavy.

Geognostic and Geographic Situations.

It has been hitherto found only in the Bannat of Temeswar, and is accompanied by ores of copper.

Observations.

1. Some specimens appear to pass, or to be nearly allied to zeolite.

2. It is named schaalstone, which in German intimates that it is composed of lamellar distinct concretions. I have not been able to find any English word synonymous to the German, so that I am under the necessity of adopting it.

3. It is composed of lime and silica.

Handwritten notes:
 The name schaalstone is proposed
 on the part of the lime genus -
 because the word scharf means sharp
 in German

NINTH SPECIES.

Stink Stone.

Stinkstein.—*Werner*.

Spathum frictione fœtidum, lapis fuillus, *Wall.* t. 1. p. 148.—Swine stone, *Kirw.* vol. 1. p. 89.—Stinkstein, *Wid.* f. 521.—*Id.* *Efner*, b. 2. f. 1023.—*Id.* *Emm.* b. 1. f. 487.—Pierre calcaire puante ou pierre puante, *Lam.* t. 2. p. 58.—Chaux carbonate fetide, *Hauy.* La pierre puante, *Broch.* t. 1. p. 567.

External Characters.

Colour is wood brown, which passes on the one side into yellowish brown, on the other into brownish and greyish black*.

Occurs massive, and sometimes disseminated through gyps.

Internally its lustre is from dull to glimmering, according to the kind of fracture.

Fracture commonly earthy, and extremely small and fine splintery; sometimes the varieties having a

* The greyish black is the marble of Brabant.

splintery

splintery fracture, show a tendency to flaty*, and the black variety has a conchoidal fracture.

Fragments indeterminately angular, not particularly sharp edged, and flaty.

Sometimes presents very small grained distinct concretions.

Translucent on the edges or opaque.

Passes from semi-hard to soft.

Not particularly brittle.

Easily frangible.

When rubbed, emits an urinous smell.

Not particularly heavy.

Chemical Properties.

When exposed to heat it loses its colour and smell, and is converted into quick lime. It effervesces powerfully with acids. *Brochant.*

Constituent Parts.

Besides lime and carbonic acid, which are its principal constituent parts, according to Vauquelin, it contains-hydr sulphure, which is the cause of the smell it emits when rubbed.

* The yellowish brown variety is most commonly flaty.

Geognostic Situation.

Found principally in beds, alternating with, or intermixed with the oldest floetz gyps.

Geographic Situation.

Occurs in considerable quantities in the district of Mansfeld in Thuringia.

Observations.

1. The light coloured varieties are the softest, the dark the hardest.
2. It must not be confounded with bituminous lime-stone.

TENTH SPECIES.

Marle.

Mergel.—*Werner*.

This species is by *Werner* divided into two sub-species

1. Marle Earth ;
2. Indurated Marle.

FIRST SUBSPECIES.

Marle Earth.

Mergel Erde.—*Werner*.

Mergel erde, *Wid.* f. 523.—Earthy marle, *Kirw.* vol. 1. p. 94. Mergelerde, *Efner*, b. 2. f. 1027.—*Id.* *Emm.* b. 1. f. 491 —Marna terrosa, *Nap.* p. 360.—La marna terrosa, *Broch.* t. 1. p. 569.

External Characters.

Its colour is yellowish grey.

Composed of dull dusty particles.

Feels rather meagre.

Soils a little.

Sometimes loose, sometimes cohering.

Light, passing into swimming.

Use.

It is principally employed for improving bad land.

Observation.

It has been conjectured to be disintegrated, indurated marle ; but of this we have no proof. *Vid. Brechant.*

Geographic Situation.

Is found in Thuringia.

 SESOND SUBSPECIES.

Indurated Marle.

External Characters.

Smoke grey, and sometimes yellowish grey.

Occurs massive.

Lustre dull, and sometimes glimmering, which latter is owing to an admixture of foreign particles.

Fracture commonly earthy, sometimes splintery, or imperfectly flaty.

Fragments

Fragments indeterminately angular, and partly flaty.

Opaque, at the utmost weakly translucent on the edges.

So soft as to yield to the nail.

Not particularly brittle.

Easily frangible.

Not particularly heavy.

Chemical Characters.

It melts before the blow pipe into a greyish black glass; it makes a brisk effervescence with acids.

Geognostic Situation.

Occurs principally in beds in the floetz lime-stone, and independent coal formations; in the first it alternates with beds of lime-stone, and sometimes occurs in nests in it.

Geographic Situations.

It is found in the coal works in the vicinity of Dresden, in those of Wehrau, and in many other places where the floetz lime-stone and coal formations occur.

Uses.

It is employed in improving bad land ; as mortar ; and when limestone is not to be found, in the smelting of certain ores of iron.

Observations.

1. It falls in the air.
2. It passes into limestone and indurated clay, which latter I suspect has been confounded by Dr. Reufs, with basalt, when he speaks of marle passing into basalt.
3. According as alumina or silica preponderates, it receives the name of clay or lime marle. Hauy believes it to be a mechanical mixture, and says it should not be considered as a mineral species. To the eye, however, it has every character of a simple fossil, therefore it is entitled to a place in a system of cryptognoſie.

ELEVENTH SPECIES.

Bituminous Marle Slate.

Bituminöser Mergel Schiefer.—*Werner*.

Bituminöser mergel schiefer, *Wid.* f. 526.—Bituminous marlite, *Kirw.* vol. 1. p. 103.—Bituminöser mergel schiefer, *Efner*, b. 2. f. 1035.—*Id. Emm.* b. 1. f. 498.—Schisto marno bituminoso, *Nap.* p. 363.—Le Schiste marno bitumineux, *Broch*, t. 2. p. 574.

External Characters.

Its colour is to be considered as intermediate between greyish and brownish black.

Massive.

Lustre either glimmering, glistening, or shining.

Fracture curved or straight slaty.

Fragments slaty.

Opaque.

Usually soft.

Somewhat mild.

Not particularly brittle.

Easily frangible.

Streak shining, but produces no change of colour.

Not particularly heavy, approaching to light.

Geognostic

Geognostic Situation.

Occurs in beds along with the oldest floetz limestone. It is frequently intermixed with ores of copper, as copper pyrites, copper glance, variegated copper ore, and rarely with copper green, copper azure, and native copper.

It contains a great number of petrified fish, that appear to be of the same species; and they are generally converted into coal, and sometimes the scales into copper ore. From the contorted aspect of these petrifications, Werner is of opinion, that the fish have been suddenly killed by an inruption, or instantaneous formation of the sulphureo-metallic matter. Accompanying the fish, petrified plants are found, which appear to belong to the genus Fucus.

Use.

As it is frequently intermixed with copper ores, it is sometimes smelted; in Thuringia, very extensive works are established for the extraction of copper from it.

TWELFTH SPECIES.

Calc Tuff.

Kalk Tuff.—*Werner*.

External Characters.

Colour yellowish grey, which sometimes approaches to smoke grey.

Seldom massive, generally perforated, or marked with impressions of reeds, grass or moss; also amorphous, ramose, and corroded.

Internally, lustre dull, seldom faintly glimmering.

Fracture is intermediate between fine grained uneven and earthy; it seldom inclines a little to fibrous and foliated.

Fragments indeterminately angular and blunt edged.

Opaque, and sometimes translucent on the edges.

Soft, passing into very soft.

Somewhat mild.

Easily frangible,

Light, approaching to swimming.

Geognostic Situation.

Occurs in alluvial land.

Geographic Situation.

Found near Langensalza in Thuringia, at Weimar, Gotha, and in many other places where springs impregnated with lime occur.

THIRTEENTH SPECIES.

Arragone.

Arragone.—*Werner*.

Arragon spar, *Kirw.* vol. 1. p. 87.—Arragonite, *Estner*,
 b. 2. f. 1039.—*Id. Emm.* b. 5. p. 357.—L'Arragonite,
Broch. t. 1. p. 576. *Id. Haüy.* t. 4. p. 337.

External Characters.

Colours are greenish grey, and pearl grey; the greenish grey passes into mountain green, and the pearl grey into pale violet blue; both colours are united in a particular manner.

In certain rare varieties it is spotted red and brown, which is owing to intermixed parts.

It is always crystallised.

1. In perfect equiangular six-sided prisms.
2. Six-sided prisms, in which two opposite lateral planes are broader, and four smaller. Sometimes the edges formed by the meeting of the smaller lateral planes are bevilled, and the edges of the bevillment are also sometimes deeply truncated — *Estner*.

The crystals sometimes adhere to one another, and form also a peculiar kind of twin crystal; are middle

sized, small, and very small; and are long, and sometimes so short as to appear tabular.

Surface very rarely quite smooth, almost always drusy, or longitudinally streaked, but commonly smooth in the middle; terminal planes, rough.

Lustre glistening, passing into shining, and is vitreous.

Fracture intermediate between imperfectly foliated and coarse, and small, and parallelly fibrous.

Colour arranged in the direction of the fibres, the longitudinal fibres green, the transverse ones violet blue.

Fragments indeterminately angular.

Translucent, and duplicating transparent.

Semi-hard, but in a higher degree than calc-spar, which it scratches.

Brittle.

Not particularly heavy.

It phosphoresces a little.

Specific gravity, *Haüy*, 2,9465.

Chemical Characters.

It effervesces with acids.

Constituent Parts.

From its resemblance to the following species, Werner is of opinion that it may contain a small portion

portion of phosphoric acid, neither Klaproth nor Thenard, however, have been able to detect in it, any thing besides lime and carbonic acid.

Geognostic and Geographic Situation.

It was first discovered in the province of Arragon in Spain, (whence its name,) where it is imbedded in gyps. More lately the industrious geognost Von Buch, has found it accompanied by fluor spar, and heavy spar, in druses of a metalliferous bed, which lies in transition rocks in the valley of Leogang, in the county of Salzburg *. It is said also to have been found in France, and in the Pyrenean mountains.

Observation.

Its specific gravity makes it intermediate between calc spar, and appatite.

* Von Buchs Geognostische beobachtungen auf Reisen durch Deutschland und Italien, b. 1. f. 225.

FOURTEENTH SPECIES.

Apatite.

Apatit.—*Werner*.

Phospholite, *Kirw.* vol. 1. p. 128.—Gemeiner apatit, *Wid.* f. 528.—Phosphorite, *Efner*, b. 2. f. 1049. *Id. Emm.* b. 1. p. 502.—Fosforite lamellare, *Nap.* p. 367.—Apatite, *Lam.* t. 2. p. 85.—L'apatite commune, *Broch.* t. 1. p. 580.

External Characters.

Its most common colours are white, green, blue, and red; all the pale colours have an intermixture of grey. Of white it presents the following varieties: greyish, reddish, yellowish, and seldom greenish white; from which it passes into mountain, seladon, pistacio, and leek green; and sometimes into olive green. It occurs also rose and flesh red, and pearl grey, from which it passes into violet blue, and lavender blue, and seldom into indigo blue. Sometimes it is also light yellowish brown.

All the colours are rather light.

Very

Very seldom massive, almost always crystallized.

Its radical crystallization is the equiangular six-sided prism, which is almost always low, and sometimes even passes into the six-sided table.

It is sometimes truncated on the lateral edges and angles, and often on the terminal edges.

The truncations of the terminal edges sometimes become so large as to pass into acuminating planes, and thus a six-planed acumination is formed; the truncations on the lateral edges form eight and twelve-sided prisms.

The lateral planes are generally longitudinally streaked, but the acuminating planes are smooth.

The crystals are middle sized and small, often bulging, and nearly round.

Externally it is splendid.

Internally its lustre is only shining, and resinous, approaching to vitreous.

Fracture imperfectly foliated; has a four-fold cleavage, of which three of the cleavages are parallel with the lateral planes, and one with the terminal planes, as is the case with beryll. Cross fracture is more or less uneven, approaching to the small conchoidal.

Fragments indeterminately angular, not particularly sharp edged.

The massive occurs in coarse grained distinct concretions.

Commonly transparent, also semi-transparent, even passing to strongly translucent.

Semi-hard but in a less degree than fluor.

Brittle.

Brittle.

Easily frangible.

Not particularly heavy, yet considerably heavier than calc spar, and rather lighter than fluor spar.

Chemical Characters.

When laid on ignited coals it emits a green light; is almost entirely soluble in nitric acid.

Constituent Parts.

According to Klaproth it contains,

Lime 0,55

Phosphoric acid 0,45

Physical Characters.

By rubbing it shews signs of electricity.

Geognostic Situation.

It occurs in tin veins, and is usually accompanied with fluor spar, brown spar, quartz, lithomarge, molybdæna, steatite, wolfram, and copper and arsenical pyrites.

Geographic

Geographic Situation.

It is found at Ehrenfriedersdorf and Schneeberg in Saxony; at Kuttenberg and Schlackenwalde in Bohemia; and in Cornwall in England.

Observations.

1. It was at one time considered as a species of schorl, afterwards, on account of its colour and crystallization, it was arranged with Beryll; others described it as fluor; but Werner soon found that it was a new species; and from its external characters gave it its present place in the system.

2. Its fallacious resemblance to other minerals induced Werner to give it this name, which is derived from the Greek word *απαταω*, to deceive.

3. Lately the chemist Trommsdorf confounded it with beryll, and equally erroneously stated that it contained a new earth, to which he gave the name of Augustite.

FIFTEENTH SPECIES.

Asparagus, or Spargel Stone.

Spargelstein.—*Werner.*

Id. Estner, b. 2. f. 1045. *Id. Emm.* b. 3. f. 359.—Chaux phosphatée verte, *Haüy*, t. 2. p. 237.—La pierre d'asperge, *Broch.* t. 1. p. 586.

External Characters.

Its principal colour is asparagus green, which in some varieties passes into greenish white; sometimes it approaches to pistacio green; and other varieties have a colour which is intermediate between orange and yellowish brown.

It occurs only crystallised, and that in equiangular six-sided prisms, which are obtusely (but not so obtuse as apatite) acuminated by six planes, which are set on the lateral planes; the lateral edges are also truncated.

The

The planes are generally longitudinally streaked, also smooth.

The crystals are imbedded, and all around crystallised, and are commonly middle sized, and small.

Internally its lustre is shining, passing into splendid, and is vitreous.

Fracture concealed foliated, passing into uneven, and perfectly conchoidal, and appears to have a three-fold cleavage parallel with the lateral planes, also a small conchoidal cross fracture:

Fragments indeterminately angular.

Most frequently translucent, and sometimes nearly transparent.

Semi-hard approaching to soft.

Easily frangible.

Brittle.

Not particularly heavy,

Specific gravity—3,098.

Chemical Characters.

It dissolves in the nitrous acid with effervescence, but does not exhibit a phosphoric light when laid on coals.

Constituent Parts.

Lime	53,32
Phosphoric acid	45,72

According to *Vauquelin*.

Geographic Situation.

Its geognostic situation, is still very imperfectly known. It has been hitherto found at Caprera, near Cape de Gate, in the kingdom of Murcia in Spain, and a bluish variety? has been found at Langloe, near Arendal in Norway,

Observations.

1. It is distinguished from appatite, with which it has been often confounded, by the following characters:—1. Its asparagus green colour. 2. Its structure, which is concentric lamellar. 3. The generally smooth surface of the planes. 4. Its acuter acuminations. 5. Its difference in specific gravity. To these may be added, 6. Its non-phosphorescence when laid on coals; and 7. Its solution in acids without effervescence?

2. It was by Romé de Lisle confounded with chrysolite; but Werner, by a careful examination of its characters,

characters, discovered that it was not allied to it, but constituted a distinct species, belonging to the calc genus.

An analysis of Klaproth, which was made some time afterwards, shewed that it was a compound of lime and phosphoric acid.

3. Haüy considers it to be identical with appatite, and Karsten arranges it a subspecies*.

* Karstens Tabellen.

SIXTEENTH SPECIES.

Boracite.

Borazit.—*Werner*.

Boracite, *Wid.* f. 533. *Id. Kirw.* vol. 1. p. 172. *Id. Estner*,
 b. 2. f. 1061. *Id. Emm.* b. 1. f. 509, *Id. Nap.* p. 370.—
 La boracite, *Broch.* t. 1. p. 589.

External Characters.

Its colours are yellowish, smoke and greyish white ; also greenish white, which passes into asparagus green.

It is always crystallized, and the following are its principal figures :

1. Cube having its edges and angles truncated.
2. When the truncations on the edges increase so much that the original planes nearly disappear, the garnet dodecaedron is nearly formed.
3. When the truncations on the angles increase so much that the original faces of the cube disappear an octaedron is formed.

Some varieties approach in figure to the crystallization of the hyacinth.

Crystals

Crystals always smooth and splendent; and are middle-sized and small.

Internally its lustre is shining which approaches to glistening, and is intermediate between adamantine and vitreous.

Fracture intermediate between imperfectly and small conchoidal, and fine grained uneven.

Fragments indeterminately angular, not particularly sharp-edged.

Commonly semitransparent, seldom passes into transparent.

Semi-hard in a high degree, equal to that of fluor spar.

Brittle.

Easily frangible.

Not particularly heavy.

Specific gravity—According to *Wesstrumb*, 2,566,

Chemical Character.

It melts without addition before the blow pipe.

Constituent Parts.

Lime	11,0
Silica	2,0
Alumina	1,0
Magnesia	13,5
Oxyd of Iron	0,7
Boracic acid	68,0

Westrumb. Naturfors. Freund. t. b.

Geographic and Geognostic Situation.

It has hitherto been found only imbedded in gyps, and but in one place, that is in the upper part of the hill of Kalkberg near Lüneburg in Hanover.

Observations.

1. Lazius who discovered it, named it cubic quartz, and Westrumb, who first analyzed it, boracic spar.

2. Hauy finds that by heating it affords positive and negative electricity. An account of his experiments is to be found in his tracts.

SEVENTEENTH SPECIES.

Fluor.

Flufs.—*Werner.*

This species is by Werner divided into two sub-species, 1. Compact fluor. 2, Fluor spar.

FIRST SUBSPECIES.

Compact Fluor.

Dichter Flufs.—*Werner*.

Fluor solidus, *Wall.* t. 1. p. 542? — Dichter flus, *Wid.* f. 542.—Compact fluor, *Kirw.* vol. 1. p. 127.—Dichter flufs, *Efner*, b. 2. f. 1067. *Id. Emm.* b. 1. f. 516.—Fluorite compatta, *Nap.* p. 374.—Le fluor compacte, *Broch.* t. 1. p. 594.

External Characters.

Its colours are greyish white, and greenish grey, sometimes also inclining a little to blue, and of various degrees of intensity.

Sometimes marked with yellowish and reddish brown spots.

Occurs massi. c.

Externally dull or feebly glimmering.

Internally glimmering and vitreous.

Fracture even, which in some varieties approaches to imperfect and flat conchoidal, in others to splintery.

Fragments

Fragments indeterminately angular, and more or less sharp-edged.

Translucent.

Semi-hard in a high degree.

Brittle.

Easily frangible.

Not particularly heavy, approaching to heavy.

Geognostic and Geographic Situation.

It is found in veins accompanied with fluor spar, at Stollberg in the Harz, but is very rare.

SECOND SUBSPECIES.

Fluor Spar.

Flus Spath.—*Werner*.

Fluor spathosus. Fluor granularis et fluor cristallifatus, *Wall.* t. 1. p. 180, 182 et 183.—Spath fusible ou vitreux, *R. d. L.* t. 2, p. 1.—Chaux fluorée, *D. B.* t. 1. p. 355: Flus spath, *Wid.* f. 558.—Foliated or sparry fluor, *Kirw.* vol. 1. p. 127 —Flus spath, *Estner*, b. 2. f. 1070. *Id.* *Emm.* b. 1. f. 519.—Fluorite lamellare, *Nap.* p. 375.—Fluor, *Lam.* t. 1. p. 78.—Chaux fluatée cristallifée, *Haüy*, t. 2. p. 247.—Le spath-fluor, *Broch.* t. 1. p. 595.

External Characters.

It presents a great variety of colours, as blue, green, yellow, white; also red and black, and seldom brown. From rose red it passes into reddish and greyish white, from this into smoke grey and pearl grey, which latter variety passes into violet blue, of various degrees of intensity, and azure blue; from this into smalt, Berlin, and sky blue; and further into verdegris, seladon, mountain, leek, emerald, grass, olive, and pistacio green, and into a colour which is intermediate between grass and emerald green

green and greenish white, which passes into apple green. It occurs also wax and honey yellow, and dark yellowish brown. The violet blue sometimes inclines to bluish black.

Often several colours together, and they are arranged in spotted, dotted, and striped colour delineations.

Massive, disseminated, and often also crystallized. Its most common figure is the cube, and to it all its other crystalline forms can be traced. The following are the principal varieties of crystallization :

1. Cube with truncated edges; when these truncating planes increase so much as to cause the faces of the cube to disappear, the garnet dodecaedron is formed*.
2. Cube with truncated angles, when these planes increase so as to cause the faces of the cube to disappear, an octaedron is formed†.
3. Cube with bevilled edges: when the bevilling planes enlarge so much as to cause the original faces of the cube to disappear, a tessular crystal with 24 triangular planes is formed;
or

* Of this rare variety there are several fine specimens in the possession of the Hon. Mr Greville, and Brochant informs us that it has been found near Breuil, and in the neighbourhood of Chalons on the Saone in France.

† Beautiful specimens of this variety are found in Cornwall.

or it may be considered as a cube having each plane divided into four*.

4. Cube having its angles acuminated by three planes, which are set on the lateral planes.
5. Cube having its angles acuminated by six planes, which are set on the lateral planes.
6. Imperfect rhomb, with cylindrical convex lateral planes.

The crystals are placed on one another, or side by side, and are from very large to very small.

Surface smooth, sometimes drusy;— in the first the lustre is splendid, in the second glimmering; the surface of the octaedron is rough.

Internally its lustre is splendid, and in some varieties passes to shining, and is vitreous, which inclines a little to pearly.

Fracture more or less perfectly foliated; and presents a fourfold equiangular cleavage, in the direction of the planes of an octaedron, or in that of a tetraedron.

Fragments tetrahedral, and sometimes octaedral.

More or less translucent, but the crystals are semi-transparent and transparent.

Occurs in large, coarse, and small grained distinct concretions; also in prismatic distinct concretions, which are intersected by curved and thin lamellar distinct concretions.

* In the magnificent collection belonging to Sir John St Aubyn, there are specimens of this variety from Cornwall and Cumberland.—*Babington's Catalogue.*

Semi-hard, but in a higher degree than calc spar.

Easily frangible.

Brittle.

Not particularly heavy.

Specific gravity.—From 3,100 to 3,200.

Chemical Characters.

Before the blow pipe it melts without addition into greyish white enamel; when laid on ignited coal, it exhibits a phosphoric light; and when two fragments are rubbed against each other in the dark they become luminous.

Constituent Parts.

Lime	57
Fluoric acid	16
Water	27

According to *Scheele*.

Geognostic Situation.

Occurs principally in veins, but also in beds in the older primitive mountains. The venigenous is of different ages, as has been ascertained by Werner; thus the oldest occurs along with tin, examples of which there are at Zinnwald in Bohemia; another is

is that which is accompanied with lead glance, and of which there are fine examples at the Halbbrücke, near Freyberg, and in Derbyshire; and a third and very distinct formation is that which is found along with copper pyrites in the Harz.

Geographic Situation.

It is found in Saxony; Harz; France; England, in Derbyshire, Cornwall and Cumberland; in Scotland it is extremely rare, the only localities I am acquainted with are Aberdeenshire and the Shetland islands; also, according to Brochant, beautiful rose coloured octaedral fluor is found at Chamouni in Savoy. In Hungary, the Bannat, and Transilvania it is rare.

Use.

It is much employed as a flux of certain ores of copper, silver and iron. When its colours are good, and the mass of considerable magnitude, it is cut into ornaments of various sizes, which are often highly valued. The acid which it contains has been also employed in the way of experiment for etching on glass.

Observation.

Observations.

Although this very interesting fossil has been mentioned as a product of many different countries, we know but little either of the formations which it constitutes, or of which it forms but a part ; and, excepting the geognostic situations which have been determined by Werner, and a few of his scholars, we meet with little or nothing in mineralogical writers but a mere list of localities. This is much to be regretted, particularly when we consider, that an acquaintance with the geognostic situation and formations of individual fossils, not only assists us very much in ascertaining their true nature, but is highly interesting in regard to the natural history of the globe. We must not, therefore, rest satisfied with the mere description, local situation, and the usual vague geognostic characters of a fossil, but must endeavour to ascertain not only the rock formation in which it occurs, but also its repository, (that is, whether it occurs in strata, beds, rock masses, veins, or kidneys), the age of this repository in regard of all others, and its general and peculiar characters.

EIGHTEENTH SPECIES.

Gyps.

This species comprehends four subspecies, 1. Gyps earth. 2. Compact gyps. 3. Foliated gyps. 4. Fibrous gyps.

FIRST SUBSPECIES.

Gyps earth.

Gipferde.—*Werner*.

Gypsum terrestre farinaceum. Farina fossilis, *Wall.* t. 1. p. 36.—Gypferde, *Wid.* p. 543.—Farinaceous gypsum, *Kirw.* vol. 1. p. 120.—Gypferde, *Efner*, b. 2. f. 1095.—*Id.* *Emm.* b. 1. f. 527.—Gesso terroso, *Nap* p. 379.—Le gypse terreux, *Broch.* t. 1. p. 601.

External Characters.

Colour yellowish white, which passes into yellowish grey, and sometimes nearly into snow white.

Intermediate between very fine scaly and dusty.

Dull and feebly glimmering.

Soils a little.

Feels meagre and a little rough, but soft and fine.

Light.

Thompson's Gypsum 21500

Geognostic Situation.

Occurs rarely; found in wet-seasons in gyps countries where, according to Werner, it is found in similar situations, and is formed in the same manner as rock milk.

Geographic Situation.

It is found near Zella and Apitz in the circle of Newstadt in Voightland. Brochant informs us that it has been also found at Mont Martre near Paris.

Use.

Like other subspecies of gyps it is employed as a manure.

Observation.

It is distinguished from rock milk by its colour, lustre, and scaly particles.

SECOND SUBSPECIES.

Compact Gyps.

Dichter Gips.—*Werner*.

Gypsum alabastrum et gypsum æquabile, *Wall.* t. 1. p. 161, 162.—Dichter gyps, *Wid.* f. 544.—Compact gypsum, *Kirw.* vol. 1. p. 121.—Dichter gyps, *Estner*, b. 2. f. 1098.—*Id.* *Emm.* b. 1. f. 529.—Gesso compatto alabaastro, *Nap.* p. 384.—Alabastrite, *Lam.* t. 2. p. 76.—Chaux fulphatie compacte, *Hauy.* t. 2. p. 266.—Le gypse compacte, *Broch.* t. 1. p. 602.

External Characters.

It occurs almost always ash grey, passing into smoke grey, also yellowish grey.

Massive.

Internally commonly dull, sometimes very faintly glimmering.

Fracture even, passing into very fine splintery.

Fragments indeterminately angular, pretty blunt edged.

Feebly translucent on the edges.

Very soft.

Rather mild.

Not particularly easily frangible.

Not particularly heavy, lighter than limestone.

Specific gravity—1,300.

Use.

It is employed in architecture and sculpture, under the name, Alabaſter.

It occurs along with foliated gyps.

THIRD SUBSPECIES.

Foliated Gyps.

Blättriger Gyps.—*Werner*.

Gypsum lamellare, *Wall.* t. 1. p. 165.—Blättriger gyps, *Wid.* f. 548. — Granularly foliated gypsum, *Kirw.* vol. 1. p. 123.—Blättriger gips, *Efner.* b. 2. f. 1109. *Id. Emm.* b. 1. f. 532.—Geffo lamellare, *Nap.* p. 381. Le gyps lamelleux, *Bröcb.* t. 1. p. 606.

External Characters.

It is commonly white, grey, and red, feldomer yellow, brown, and black. Of white it presents the following varieties: snow, greyish, yellowish, and reddish white; from reddish white it passes into flesh red, blood red, and brick red; the greyish white passes into ash grey and smoke grey, and greyish black; the yellowish grey passes into wax yellow. It occurs very feldom hair brown, and this only when it is intermixed with stink-stone.

It presents spotted, striped, and veined colour delineations.

It

It occurs massive, also in blunt edged pieces, that approach to the roundish. Seldom crystallised and when it is so, the crystals are conical lenses imbedded in clay.

Internally its lustre alternates from shining and glistening to glimmering, and is intermediate between pearly and vitreous.

Fracture nearly perfect and rather curved foliated, with a single cleavage. Some varieties shew a short and broad scopiformly and stellularly diverging radiated fracture.

Fragments indeterminately angular and blunt edged.

The massive occurs in coarse, small, and fine grained distinct concretions, even sometimes passing into compact. The radiated occurs in prismatic distinct concretions.

Translucent, and duplicating, according to Hauy.

Very soft.

Rather mild.

Not particularly difficultly frangible.

Light, passing into not particularly heavy.

Observations.

This species has been confounded with granular limestone, to which indeed it bears a strong resemblance; but its blunt edged fragments and softness, independent of other characters, distinguish it sufficiently from granular limestone.

FOURTH SUBSPECIES.

Fibrous Gyps.

Fafriger Gips.—*Werner*.

Gypsum striatum, *Wall.* t. 1. p. 167.—Fafriger gyps, *Wil.* f. 546.—Fibrous gypsum, *Kirw.* vol. 1. p. 122 —Fafriger gips, *Efner.* b. 1. f. 1105. *Id. Emm.* b. 1. f. 536.—Gesso fibroso, *Nap.* p. 386 —Chaux fulphatie fibreux, *Hay.* t. 2. p. 266.—Le gypse fibreux, *Broch.* t. 1. p. 604.

External Characters.

Its principal colours are white, grey, and red ; of white it presents the following varieties : yellowish, greyish, snow, and reddish white. From reddish white it passes into flesh red, and light hyacinth red ; the yellowish white passes into yellowish grey ; of grey the only variety is ash grey. All the colours in this subspecies are paler than in the preceding subspecies.

Occurs massive and dentiform ; the latter is longitudinally streaked.

Internal

Internal lustre mostly glistening, yet sometimes passes into shining and splendid; and is pearly.

Fracture parallelly fibrous, passing from delicately fibrous to broad fibrous, bordering on radiated, and generally somewhat curved. There is a particular variety which has a double fracture, in it the cross fracture is fibrous, and the longitudinal foliated.

Fragments mostly splintery.

Commonly semi-transparent and translucent; the variety with double fracture semi-transparent.

Very soft.

Rather mild.

Not particularly brittle.

Easily frangible.

Not particularly heavy.

Chemical Character.

When exposed to the flame of a blow pipe it becomes opaque, and is changed into a white enamel, which in twenty-four hours falls into powder. *Lelievre*. When pure it produces no effervescence with acids.

Geognostic Situation of Gyps.

The fossils belonging to this species, according to Werner, constitute three very distinct formations; and, from the late observations of Von Buch, probably a fourth may be added.

It is not improbable that when we become acquainted with the gyps formation of Mont Martre, it will prove to be much newer than the third gyps formation, even younger than the newest flötz trap.

The oldest gyps occurs in primitive mountains; the second or the oldest floetz gyps lies over the oldest floetz limestone, and is accompanied with rock salt and flink-stone; the third or newer gyps lies over the second or variegated sandstone formation, and under the second floetz limestone. The fibrous gyps occurs in, and is characteristic of, the third formation, as the foliated is of the second.

The formation discovered by Von Buch appears to lie in transition rocks, so that, if it shall be confirmed, it must be placed between the primitive and floetz formations.

Geographic Situation.

The oldest formation has only been discovered in one place, that is, near to Bellinzona, in the Alps of Italian Switzerland. The transition gyps of Von Buch occurs in the valley of Leogang, in the county of Salzburg; the two floetz formations are found in abundance in the province of Thuringia.

In England, it occurs in Derbyshire, but to what formation the gyps of that county belongs we know not, as no well educated geognost has ever communicated any observations regarding it. It occurs also in considerable quantity in Cumberland, and of these, as far as I am able to judge, that which occurs in the

neighbourhood of Carlisle, appears to belong to the old floetz formation. Near the village of Moffat, in the county of Dumfries in Scotland, fragments of gyps are found imbedded in a conglomerate, which reposes on transition rocks; but to what formation it belongs, or if it is accidental, has not been determined.

Use.

When deprived of its water of crystallization by burning, and then powdered and mixed with determinate portions of water, it forms an excellent cement; it is also used for many ornamental purposes, the detail of which belongs to œconomical mineralogy.

Observations.

It is worthy of remark that gyps frequently contains other fossils imbedded, as quartz, boracite, arragone, and native sulphur.

NINETEENTH SPECIES.

Selenite.

Fraueneis.—*Werner*.

Gypsum selenites, *Wall.* t. 1. p. 165.—Selenite, *R. d. L.* t. 1. p. 441.—Fraueneis, *Wern. Cronst.* f. 53.—Broad foliated gypsum, *Kirw.* vol. 1. p. 123.—Fraueneis, *Emm.* b. 1. f. 540.—Chaux sulphatée crystalisée, *Hauy.* t. 2. p. 266.—La selenite, *Broch.* t. 1. p. 609.

External Characters.

Its principal colour is snow white, which passes into yellowish and greyish white; from greyish white it passes into smoke grey, and seldom into ash grey; from yellowish white it passes into wax, honey, and ochre yellow, and into yellowish brown; but this latter colour is produced by an intermixture with flinkstone. Is most generally massive, and not unfrequently crystallised as follows:

1. Pretty oblique six-sided prism, having two opposite planes larger, and four opposite smaller, and rather flatly bevilled on both extremities, the bevilling planes set oblique-

ly, yet parallelly on the broader lateral planes, so that it has a rhomboidal aspect; when very short it passes into the rhomb.

2. The same prism acuminated at both extremities by four planes, which are set on the lateral edges that bound the two larger planes.
3. Twin crystals which are formed by the incorporation of two of the preceding crystals, in the direction of their breadth, in such a manner that the united summits at one extremity form a re-entering angle, but at the other a four-planed acumination.
4. Sometimes the prisms, 1. 2. are terminated by spherical convex planes. If the prism disappears, and these planes come together, a spherical convex lens is formed.

The lens is often columnarly aggregated.

The broader lateral planes are smooth, the others are longitudinally streaked and shining. The planes of the lens are dull and rough.

Crystals are seldom large, generally middle sized.

Internally its lustre is shining and splendid, and is pearly.

Fracture is perfectly foliated, mostly straight, often curved, with one perfect and two imperfect cleavages; the two latter intersect the former obliquely, and they are intersected rectangularly by the first or perfect cleavage, and this arrangement gives rise to rhomboidal fragments.

Massive varieties are sometimes unseparated, sometimes shew large, coarse, small, and fine grained concretions. Surface of the concretions is generally very uneven.

Completely transparent.

Very soft.

Very mild.

A little commonly flexible.

Easily split in the direction of the principal fracture.

Not particularly easily frangible.

Not particularly heavy approaching to light.

Specific gravity—2,322,

Constituent Parts.

Lime	50
Sulphuric acid	47
Water	21
	—
	600

According to *Bergman*.

Geognostic Situation.

It is found in the oldest gyps formation, and in single crystals, in clay beds in the newest formations; sometimes in veins in primitive mountains, of which Werner mentions two instances, in his translation of Cronsted, one at Herregrunde near

near Newfol, where it occurs in veins of copper pyrites and fahl ore; the other at Tetschen in Bohemia, in a vein of lead glance.

Geographic Situation.

It is found in Thuringia, at Mont Martre near Paris; England, as in Oxfordshire, Isle of Sheppy, &c.

Uses.

On account of its purity it is employed in taking the most delicate impressions; also for crayons, and, when burnt and powdered, it is used for cleansing silver.

TWENTIETH SPECIES.

Cube Spar.

Wurfelspath.—*Werner*.

Muriacite, *Klaproth*.—Anhydrous sulphat of lime, *Haüy*,
t. 4. p. 348.

External Characters.

Its colour is milk white, which sometimes passes into greyish white, yellowish white, and reddish white; which latter approaches to pearl grey.

Massive.

Lustre shining, passing into splendid, and perfectly pearly.

Fracture perfectly foliated, presenting a three-fold rectangular cleavage.

Fragments cubical.

Occurs in large, coarse, and small grained distinct concretions; also in broad prismatic and thin and straight and rather longish lamellar distinct concretions.

Translucent.

Translucent.

Soft*.

Uncommonly easily frangible.

Not particularly heavy.

Specific gravity—2,964, *Haüy*.

Constituent Parts.

According to Klaproth, who names it muriacite, it contains 0,15 sea salt, 0,27 gyps, and 0,28 of sand and lime. Vauquelin has analyzed a fossil said to be the same, but found no sea salt nor water of crystallization, whence he names it anhydrous sulphat of lime.

Geognostic and Geographic Situation.

It is found in salt rocks in the archbishopric of Salzburg.

* Scratches calcspar, and more strongly gyps. *Haüy*.

SEVENTH GENUS.

BARYTE GENUS.

FIRST SPECIES.

Witherite.

Witherit.—*Werner*.

Baryt aerée *De Born*. t. 1. p. 267.—Witherite, *Wid.* f. 554.
 —Barolite, *Kirw.* vol. 1. p. 134.—Luft or Kohlenfaurer
 Baryt, *Efner*, b. 2. f. 1124.—Witerite, *Nap.* p. 387.
Id. Lam. t. 2. p. 20.—Baryte carbonatée, *Hauy*, t. 2.
 p. 309.—La Witherite *Broch*, t. 1. p. 613.

External Characters.

Commonly light yellowish grey, passing into a middle colour between yellowish white, and greyish white.

Most commonly massive, but sometimes also crystallised in

1. Six-sided prisms acuminate by six planes which are set on the lateral planes.
2. The same prism, in which the edges that separate the lateral and acuminate planes are truncated.
3. Double six-sided pyramids.

Lustre of the principal fracture is shining, cross fracture glistening and resinous.

Principal fracture is intermediate between floriformly foliated, and narrow and scopiformly diverging radiated, and approaches sometimes more to the one, sometimes more to the other. It appears to possess several cleavages; cross fracture is fine grained uneven, passing into splintery.

Fragments generally wedge shaped.

Massive varieties are composed of indistinct wedge-shaped, prismatic distinct concretions, that often pass into large and coarse grained distinct concretions, which are very much grown together.

Translucent, passing into semi-transparent.

Soft, and semi hard.

Brittle.

Easily frangible.

Heavy, approaching to not particularly heavy, lighter than heavy spar.

Specific gravity—4,300 to 4,338.

Chemical Characters.

It melts without addition before the blow pipe into a white enamel. It dissolves with effervescence in acids. Paper when dipped in a solution of nitrate of baryte exhibits, on burning, a yellow flame, but when immersed in solution of nitrate of strontian, a purple flame.

Constituent Parts.

Carbonat of baryte	98,246		
Carbonat of strontian	1,703		
Alumina with iron	0,43		
Carbonat of copper	0,8		
Barytes		62	74,5
Carbonic acid		22	25,5
Water		16	
	<hr/>	<hr/>	<hr/>
	100	100	100,0

*Klaproth. b. 2. p. 86.**Pelletier. Vauquelin. Haug.
Min. t. 2 p. 309.**Geognostic Situation.*

According to the observations of Mr Watt, jun. a scholar of Werner, it occurs in veins along with
4 E 2 heavy

heavy spar, lead glance, blende and calamine; these veins traverse the independent coal formation.

Geographic Situation.

It is found at Anglefark in Lancashire; other localities have been mentioned, but they are doubtful.

Use.

It is a very active poison, but its combination with muriatic acid, when used with caution, has been found serviceable in scrophula.

SECOND SPECIES.

Heavy Spar or Baryte*.

Schwer Spath.—*Werner*.

This species is by Werner divided into eight subspecies, viz. 1. Heavy spar earth. 2. Compact heavy spar. 3. Granular heavy spar. 4. Curved lamellar heavy spar. 5. Straight lamellar heavy spar. 6. Columnar heavy spar. 7. Prismatic heavy spar. 8. Bolognese spar.

* The term Baryte has been universally adopted by chemists: the English denomination, Heavy Spar, is, however, for many reasons, to be preferred.

FIRST SUBSPECIES

Heavy Spar Earth.

Schwerspath Erde.—*Werner*.

Baryte vitriolée terreuse, *De Born*, t. 1. p. 268.—Schwerspath erde, *Wid.* f. 558.—Earthy barofelenite, *Kirw.* vol. 1. p. 138.—Schwerspath erde, *Eßner*, b 2 f. 1143. *Id. Emm.* b. 1. f. 550.—Baryt-vitriolata terrea, *Nap.* p. 402.—Le spath pesant terreux, *Broch.* t. 1. p. 617.

External Characters.

Its colours are reddish and yellowish white.

It consists of glimmering, and generally coarse earthy particles, that are intermediate between dusty and scaly, and sometimes rather angular.

Occurs massive.

Does not soil.

Sometimes loose, sometimes more or less cohering, or of friable consistence.

Feels rough and coarse, meagre and somewhat sharp.

Not particularly heavy, approaching to heavy.

Geognostic and Geographic Situations.

Occurs in drusy cavities in veins of heavy spar. It has been found in one of the 'levels of the mine called Krieg and Frieden near Freyberg; also in the mines of Staffordshire and Derbyshire in England. Other localities are mentioned, but on doubtful authority.

Observations.

1. It is well distinguished from all other earthy minerals by its greater specific gravity.
2. It has been supposed to be compact heavy spar disintegrated, but its occurrence in close cavities appears on the contrary to shew that it is an original powdery deposit.

SECOND SUBSPECIES.

Compact Heavy Spar.

Dichter Schwerspath.—*Werner*.

Baryte vi,riolata compacte, *De Born*. t. 1. p. 268.—Dichter schwerspath, *Wid.* f. 559.—Compact barofelenite, *Kirw.* vol. 1. p. 138. — Dichter schwerspath, *Esfner*, b. 2. f. 1146. *Id. Emm.* b. 1. f. 552.—Barite vitriolata compacta, *Nap.* p. 400.—Le spath pesant compacte, *Broch* t. 1. p. 618.

External Characters.

Its colour is yellowish white, which passes into greyish white.

Occurs massive, and with fine drusy cubic and reniform impressions.

Lustre glimmering, when passing into the following species glistening.

Fracture coarse earthy, passing into fine grained uneven; sometimes it is indistinctly granularly foliated.

Fragments indeterminately angular, rather blunt-edged.

Occurs

Occurs sometimes in thick and curved lamellar distinct concretions.

Opaque, sometimes translucent on the edges.

Very soft, and soft.

Rather mild.

Not particularly brittle.

Easily frangible.

Feels meagre.

Heavy.

Geognostic Situation.

Found in metalliferous veins.

Geographic Situation.

Found in mines in the Freyberg mining field; also in the mines of Staffordshire and Derbyshire; where it is known under the name Cawk. Mr Servoz, according to Brochant, is said to have found in clay slate near to Servos in Savoy.

Observation.

In the mines of Freyberg we can observe on one hand the transition from this species into earthy heavy spar, on the other into foliated heavy spar.

THIRD SUBSPECIES.

Granular Heavy Spar.

Körniger Schwerspath.—*Werner.*Le spath pesant grenue, *Broch. t. 1. p. 620.**External Characters.*

Colour sometimes snow white, sometimes milk white, which passes into dark smoke grey.

Occurs always massive.

Internally its lustre is between glistening and glimmering, and is pearly.

Fracture small and fine foliated, and seems to pass into splintery.

Fragments indeterminate angular and blunt edged.

It presents fine, seldom small grained distinct concretions; they are sometimes so minute as no longer to be visible, when it passes to splintery.

Feebly translucent.

Soft.

Not particularly brittle.

Easily

Easily frangible.

Heavy.

Geognostic and Geographic Situations.

It is found in beds along with galena, at Peggau in Stiria; also in the mining field of Freyberg, and at Schlangenberg in Siberia, where it is accompanied with copper green and native copper.

Observations.

1. It bears a striking resemblance to granular limestone, from which, however, it is distinguished by the following characters:

1. It has less lustre.
2. When the distinct concretions are of the same size as in granular limestone, they are not so well defined.
3. It is softer, and
4. It is much heavier.

2. The greater or less singular distinctness of the concretions, affords, to an experienced eye, a good mark by which to distinguish granular limestone, granular heavy spar, and granular gyps from one another; thus in granular limestone they are well defined, in granular heavy spar less so, and in granular gyps still more indistinct.

The bluntness of the fragments can also, by an experienced eye, be used for distinguishing these species from one another.

FOURTH SUBSPECIES.

Curved lamellar Heavy Spar.

Krumm-schaaliger Schwerspath.—*Werner*.

Le spath pesant testacé courbe, ou le spath lamelleux,
Broch. t. 1. p. 621.

External Characters.

Its principal colours are white, grey and red. Of white the following varieties occur:—yellowish, greyish, and reddish white. Of grey it presents yellowish smoke, and pearl grey. From pearl grey it passes into flesh red and blood red; the yellowish grey passes into yellowish brown*.

The yellowish brown variety occurs only in England.

Sometimes

Sometimes several colours occur together, and are distributed in broad striped delineations.

Occurs most commonly massive, frequently reniform, also globular and with impressions; also in small lenses and four-sided tables, which have always a drusy surface.

Internally its lustre is glistening passing into shining, and is intermediate between pearly and resinous.

Fracture generally curved foliated, and some specimens pass into splintery, (the latter has the least lustre), even into scopiformly diverging radiated; this has most lustre.

Fragments generally indeterminately angular, blunt edged.

It is commonly composed, particularly the reniform, of curved and thick lamellar distinct concretions, which are bent in the direction of the external surface, and according to which the colour is arranged.

More or less translucent.

Soft, in a low degree.

Easily frangible.

Heavy.

For its geognostic and geographic situations see the following subspecies.

FIFTH SUBSPECIES.

Straight lamellar Heavy Spar.

Géradschaaliger schwerspath.—*Werner.*

This species is by Werner divided into two kinds,
a. Fresh straight lamellar Heavy Spar. *b.* Disintegrated straight lamellar Heavy Spar.

a. Fresh straight lamellar Heavy Spar.

Frischer geradschaaliger schwerspath.—*Werner.*

External Characters.

Its most common colours are white and red. Of white it presents the following varieties:—milk, yellowish and reddish white. Of red, flesh, blood and brownish

brownish red. It occurs also greyish black, but that is a very rare variety.

The preceding are the colours of the massive; the crystallized possesses besides these, grey, yellow, green and brown. The following are the varieties of each colour that occurs:—grey, yellowish and greenish grey; green, olive, and oil green; yellow, wax, honey and wine yellow, and yellowish brown, which approaches to liver brown; also of a middle colour between smalt blue and bluish grey, which approaches to indigo blue.

The colours are light and somewhat muddy.

The red colour occurs very seldom in the crystallized varieties.

It is most frequently massive, but also very often crystallized; the two radical crystallizations are

1. Oblique four-sided table.
2. Rectangular four-sided table.

1. *Oblique four-sided table.*

a. Perfect.

b. The obtuse terminal edges truncated; when these become large, a six-sided table is formed.

c. All the angles truncated; when these truncating planes increase until they meet, bevillments are formed. The bevillments on the obtuse terminal edges are sometimes very deep, and a second time bevilled, and the
second

second bevillment twice broken; sometimes the edges of the obtuse, and more rarely the edges of the acute bevillment, are truncated.

d. By the increase of the bevillment on all the terminal edges, the transition is made into the rectangular table, bevilled on the terminal planes.

2. *Rectangular four-sided table.*

a. Perfect.

b. All the terminal planes bevilled, and the still remaining part of the planes form truncations on the angles; when these truncations increase, the four-sided passes into

c. An eight-sided table, which presents the following varieties:—

α. Truncated on all its lateral edges.

β. Having all its terminal planes bevilled, and the edges of the bevillments truncated.

δ. The bevillments in *c.* are sometimes rounded off, and thus a kind of lens is formed.

The planes of the crystals are smooth, generally splendid and pearly.

Internally its lustre is shining, which sometimes approaches to splendid, sometimes, to glistening, and is commonly intermediate between pearly and vitreous.

Fracture more or less perfectly straight foliated, having a perfect and a little obliquely intersecting three-fold cleavage.

Fragments rhomboidal, approaching to cubical.

Occurs in distinct concretions, which are straight lamellar, and are from thin to very thick; they are thicker at one extremity than another, hence they are rather wedge-shaped, and their cross fracture exhibits a scopiformly diverging aspect.

The massive varieties are translucent, the crystallized transparent and semitransparent, and is duplicating.

Soft, scratches calc spar, but is scratched by fluor spar.

Not particularly brittle.

Easily frangible.

Heavy.

Specific gravity.—4,300 to 4,500.

Chemical Characters.

It melts without addition before the blow pipe into a solid white enamel, and when pure does not effervesce with acids.

Constituent Parts.

Barytes	84	67,2
Sulphuric acid	13	32,8
Water	0,3	

Bergman.

Withering.

4 G

Klaproth

Klaproth found in several varieties of heavy spar, small portions of sulphate of strontian, filica, oxyd of iron, and alumina.

Geognostic Situation.

Occurs almost always in veins, seldom in beds. In primitive mountains it is found in considerable quantity, but is more abundant in the transition rocks. It occurs in beds and veins in the floetz formations, and continues even to the newest floetz trap, where it lines druses, and forms veins.

Geographic Situation.

Besides Saxony, it occurs in Hungary, Bohemia, the Harz; England; Scotland, Leadhills, Wanlock head, the rocks belonging to the floetz trap formation in the vicinity of Edinburgh, and island of Arran, where it probably occurs in beds.

b. Disintegrated Heavy Spar.

Mulmicher oder Mürber geradschaaliger Schwer-
spath.—*Werner.*

External Characters.

Its colours are greyish, yellowish, and reddish white.
Generally massive.

Lustre shining, passing into glistening.

Fracture and distinct concretions the same as in the
preceding kind, but less distinct.

Faintly translucent on the edges, or nearly opaque.

Soft, passing into very soft.

Not particularly brittle.

Very easily frangible.

Heavy.

SIXTH SUBSPECIES.

Columnar Heavy Spar.

Stangenspath.—*Werner*.

Id. Emm. b. 1. f. 569.—Le spath pesant en barres, *Brosb.*
t. 1. p. 631.

External Characters.

Its colour is yellowish, milk, greyish, and greenish white.

Is always crystallised in acicular oblique four-sided prisms, which are columnarly aggregated, and intersect one another.

Externally and internally it is shining, passing to splendid, and perfectly pearly.

Fracture straight foliated, with a three-fold cleavage.

Fragments rhomboidal.

It probably also occurs in granular distinct concretions.

Translucent.

Soft.

Not

Not particularly brittle.

Easily frangible.

Heavy.

Geognostic and Geographic Situation.

It is found in metallic veins, accompanied by fluor spar, quartz, and other subspecies of heavy spar. It was formerly found in considerable quantity in the vein of Lorenzgegen Trum near Freyberg; is found in the mines of Scharfenberg near Meissen, and in those in the vicinity of Marienberg. It is also found in Derbyshire.

Observations.

It has been by some confounded with schorl, by others with white lead ore. To schorl it has no resemblance, but it might be confounded with white lead ore. It is however easily distinguished from it by the following characters: white lead ore has an adamantine lustre, its fracture is small conchoidal, and its specific gravity is 6,5585; on the contrary, columnar heavy spar has a pearly lustre, fracture is foliated, and its specific gravity is not above 4,500.

SEVENTH SUBSPECIES.

Prismatic Heavy Spar.

Saulen Schwerspath.—*Werner*.

External Characters.

Its colours are greenish grey, yellowish grey, ash grey, smoke grey, and pearl grey; the pearl grey passes into flesh red; it occurs also pale indigo blue.

The flesh red colour is very rare.

Occurs massive, but most commonly crystallised. The following are its crystalline figures.

1. Oblique four-sided prism acutely bevelled on both extremities, the bevilling planes set on the acute lateral edges. Sometimes one of the bevilling planes is so large as to cause the other to disappear.
2. Oblique four-sided prism acuminated by four planes, which are set on the lateral edges. This figure is produced by the deep truncation of the extremities of the obtuse lateral edges.
3. When the bevilling planes approach to each other by the prism becoming shorter, the lengthened octaedron is formed.

4. The

4. The two opposite obtuse lateral edges are sometimes truncated, and thus a six-sided prism is formed

Crystals are middle sized and small, form druses, and intersect one another.

Lustre is shining and splendid, and resinous, or pearly?

Fracture is lamellar or foliated, with a three-fold cleavage like lamellar heavy spar.

It occurs in coarse and small grained distinct concretions, and this distinguishes it from lamellar heavy spar.

Generally translucent, crystals are often transparent.

Soft.

Not particularly brittle.

Uncommonly easily frangible, more so than lamellar heavy spar.

In other characters the same as the preceding subspecies.

Geographic Situation.

Found in mineral veins in Saxony.

Observation.

It was formerly confounded with lamellar heavy spar.

EIGHTH SUBSPECIES.

Bolognese Spar.

Bologneser Spath.—*Werner*.

Gypsum spathosum opacum semipellucidum, *Wall.* t. 1. p. 169 —Var. of blättriger schwerspath, *Wid.* f. 561.—Bologneserstein, *Emm.* b. 4. f. 572.—Litheosphore, *Lam.* t. 2. p. 24.—Baryte sulphatée rayonnée, *Hauy*, t. 2. p. 302.—Le spath de Bologne ou la pierre de Bologne, *Broch.* t. 1. p. 633.

External Characters.

Its colour is smoke grey, which passes into ash grey and yellowish grey.

It occurs in roundish and blunt edged flatly compressed pieces, having an uneven surface; some pieces have even the spheroidal shape of the lens; others exhibit traces of a low three sided pyramid.

Internally its lustre is sometimes shining, sometimes glistening and resinous.

Fracture is parallelly, stellularly, and scopiformly diverging radiated; sometimes also foliated in certain directions

directions, resembling in this particular the fracture of Arragone.

Fragments are sometimes wedge shaped, sometimes indeterminately angular.

Sometimes occurs in large grained distinct concretions, in which the rays in each concretion have a different direction; sometimes the concretions are wedge shaped, and even pass into unseparated.

Strongly translucent.

In other characters it agrees with the preceding subspecies.

Geognostic and Geographic Situations.

Werner informs us that it is found imbedded in clay and marle rocks at Monte Paterno, near Bologna in Italy; the unequal surface of the roundest masses, which are found loose, shew, as Werner well observes, that they have not received their rounded form from attrition, but owe it to their imbedment.

EIGHTH GENUS.

STRONTIANE GENUS.

FIRST SPECIES.

Strontiane.

Stronthian.—*Werner.*

Id. Wid. f. 571. *Id. Kirw.* vol. 1. p. 332. *Id. Esner,* b. 2. f. 48.—Kohleufaurer frontianit, or frontiane carbonatée, *Emm.* b. 3. f. 310.—Strontianite, *Nap.* p. 391.—Strontites, *Hope, Edin. Transf.* vol. 1. *Id. Lam.* t. 2. p. 130.—Strontiane carbonatée, *Haüy,* t. 2. p. 327.—La frontianite, *Broch.* t. 1. p. 637.

External Characters.

Its most common colour is intermediate between asparagus and apple green, often also greenish white. Sometimes both colours occur together in the same specimen.

It occurs most commonly massive, and sometimes crystallised in acicular crystals, that appear to be six-sided prisms pretty flatly acuminate by six planes.

The crystals are scopiformly and manipularly aggregated.

The lustre of its principal fracture is shining and glistening, cross fracture glistening, and is pearly.

Principal fracture narrow, straight, and scopiformly diverging radiated; towards the centre of the radiation it appears always white.

Cross fracture is fine grained uneven.

It is still uncertain whether or not it occurs in distinct concretions; perhaps it may shew a tendency to wedge shaped concretions.

Translucent in a greater or lesser degree.

Soft and semi-hard.

Brittle.

Easily frangible.

Not particularly heavy, approaching to heavy.

Specific gravity—3,675, *Klaproth*.—3,400 to 3,644,

Kirwan.

Chemical Characters.

Before the blow pipe, without addition, it becomes white, but does not melt, and if afterwards exposed to the air it falls into powder. It has not the same

poisonous properties with Witherite. It dissolves in acids with effervescence. If we dip a piece of paper into a solution of nitrate of strontian and allow it to dry and then inflame it, it burns with a very beautiful carmine red colour. *Brochant.*

Constituent Parts.

Strontiane	61,21	69,5	62,0
Carbonic acid	30,20	30,0	30,0
Water	8,50	0,5	8,0
	<hr/>	<hr/>	<hr/>
	100,0	100,0	100,0
According to	<i>Hope,</i>	<i>Klaproth,</i>	<i>Pelletier.</i>

Geognostic and Geographic Situations.

It has been hitherto found only at Strontian in Argyleshire, where it occurs along with lead glance, heavy spar, calc spar, and iron pyrites, in a vein that traverses gneifs*.

* The kind of rock may still remain doubtful, as the authority of the foreign mineralogist who first announced it is not of the highest kind.

Observations.

Observations.

Dr Hope, in his masterly memoir published in the Edinburgh Philosophical Transactions for 1790, first made us acquainted with the peculiar earth which this genus contains. It afterwards engaged the attention of other able chemists, particularly Kirwan, Klaproth, Pelletier, and Vauquelin.

a grey

SECOND SPECIES.

Celestine.

Celestin.—*Werner*.

Schwefel saurer strontianit, *Estner*, b. 2. f. 1185. *Id. Emm.*
b. 3. f. 312—Strontiane sulphatée, *Hauy*, t. 2. p. 327.
La celestine, *Broch*. t. 1. p. 640.

This species is by *Werner* divided into two sub-species. 1. Fibrous Celestine. 2. Foliated Celestine.

FIRST SUBSPECIES,

Fibrous Celestine.

Fafriger Celestine.—*Werner*.

External Characters.

Its colour is intermediate between indigo blue and bluish grey, and sometimes passes into milk white; said also to occur pale sky blue. It loses its colour in keeping, even if very carefully preserved.

It occurs massive and in plates, also crystallised.

Lustre of the longitudinal fracture shining, cross fracture glistening and pearly, or between pearly and resinous.

The longitudinal fracture is foliated, but this is seldom to be observed, as it does not break easily in that direction. Cross fracture parallel, coarse, and rather curved fibrous.

Fragments splintery.

It shews a tendency to prismatic distinct concretions, which appear to be parallel and conformable with the fibrous fracture.

Translucent.

From

From soft to semi-hard.

Easily frangible.

Heavy, but not in a high degree.

Specific gravity—3,830, *Klaproth*.

Geognostic and Geographic Situation.

Its geognostic situation is very imperfectly known, it is suspected to occur in marle. It is found at Frankfort in Pennsylvania, and also at Bouvron near Toul in France, according to Brochant.

SECOND SUBSPECIES.

Foliated Celestine.

Blättriger Celestin.—*Werner*.

External Characters.

Its colour is milk white, which falls into blue.

It occurs massive, and is crystallised in six-sided tables that intersect one another.

Lustre glistening, approaching to shining.

Fracture imperfectly foliated, with a two-fold cleavage, perhaps a three-fold cleavage.

Fragments indeterminately angular.

Occurs in thin and straight, generally a little curved lamellar loosely aggregated concretions, which are collected into large granular concretions.

Strongly translucent, the crystals rarely transparent.

Soft, approaching to semi-hard.

Not particularly brittle.

Easily frangible.

Heavy.

Geognostic Situation.

Sometimes occurs in sulphur beds. *Vide Nat. Journal.*

Geographic Situation.

Is found very finely crystallised in Sicily; also in the South of England, near Bristol.

Observations.

1. Celestine has been also found crystallised in

a. Oblique four-sided prisms having sometimes alternately broader and narrower lateral planes, and acuminate by four planes which are set on the lateral edges, and which terminate in a line which is in the direction of the acuter lateral edges.

b. Sometimes the acuter lateral edges, and the edges formed by the meeting of the acuminate planes are truncated.

These crystallizations belong to a subspecies that may be denominated radiated celestine, and which differs from the foliated in crystallization, aggregation of crystals, fracture, and distinct concretions.

2. There is found, imbedded in clay, in the gyps quarries of Mont Martre near Paris, a compact subspecies

pecies of celestine, of which Brochant gives us the following description:—Colour bluish grey. Occurs massive. Fracture splintery. Opaque. Semi-hard, passing to soft. Somewhat frangible. Rather mild. Specific gravity 3,500.

The specimens in my collection possess the following characters:

Colour yellowish grey. Occurs in flattened spheroidal and kidney shaped pieces; which are often internally traversed by rents, that divide its surface into quadrangular pieces: the surfaces of these pieces are drusy. Fracture fine splintery, and sometimes minute foliated. Opaque, and sometimes translucent on the edges. Soft, passing into semi-hard. Easily frangible. Mild. Heavy. Specific gravity 3,596. Constituent parts, according to *Vauquelin* *J. d. M.* n. 53. p. 355.

Sulphat of strontiane	91,42
Carbonate of lime	8,33
Oxyd of iron	0,25

Celestine may thus be divided into four subspecies.

1. Compact.
2. Fibrous.
3. Radiated.
4. Foliated.

The first of these is the fact that the
... of the ...
... of the ...

The second of these is the fact that the
... of the ...
... of the ...

The third of these is the fact that the
... of the ...
... of the ...

The fourth of these is the fact that the
... of the ...
... of the ...

EXPLANATION

OF THE

PLATES.

I AM indebted to Count de Bournon and Abbé Hauy, two of the most able and distinguished crystallographers of the present age, for the greater number of the figures that accompany this work. I intended to have completed the crystal suites of several of the species that are still imperfect, but want of leisure and opportunity has prevented me.

DIAMOND.

Fig. 1. Octaedron.

Fig. 2. Octaedron, in which each plane is divided into six, so that the figure has 48 triangular faces*.

* We hope Count de Bournon will soon gratify the mineralogical public with an account of the highly interesting suite of diamonds, which are in the collection of the Hon. Mr. Greville.

ZIRCON.

Fig. 3. Rectangular four-sided prism, acuminated by four planes, which are set on the lateral planes.

Fig. 4. Same figure, in which the angles formed by the meeting of the acuminating and lateral planes are bevilled.

Fig. 5. Same figure as the preceding, in which the terminal edges are truncated.

HYACINTH.

Fig. 6. Rectangular four-sided prism, acuminated by four planes, which are set on the lateral edges.

CHRYSOBERYLL.

Fig. 7. Flat, double six-sided pyramid, in which the summits of the acuminations are truncated.

Fig. 8. Longish, thick six-sided table.

CHRYSOLITE.

Fig. 9. Described in No. 1. and 2. p. 42 and 43.

AUGITE.

Fig. 10. Six-sided prism, with two broader and four smaller lateral planes, bevilled on both extremities, and the bevilling planes set on obliquely but parallelly on those lateral edges, which are formed by the smaller lateral planes.

Fig. 11. Differs from the preceding in having the edges formed by the meeting of the smaller lateral planes truncated.

VESUVIANE.

Fig. 12. Rectangular four-sided prism, truncated on the lateral and terminal edges.

13. Same

13. Same figure, acuminated by four planes, which are set on the lateral planes, and the extremities of the acuminations pretty deeply truncated.

GARNET.

Fig. 14. Garnet dodecaedron.

Fig. 15. Garnet dodecaedron, having all its edges deeply truncated; it is the intermediate crystal between the dodecaedron and the following figure.

Fig. 16. Which is a double eight-sided pyramid, acuminated by four planes.

Fig. 17. Preceding figure, in which the truncations mark its progress to the garnet dodecaedron; and the acuminations its progress from the garnet dodecaedron.

GRENATITE.

Fig. 18. As described at page 76.

SPINELLE.

Fig. 19. Octaedron. Fig. 20. Lengthened octaedron. Fig. 21. Acute rhomboid. Fig. 22. Preceding figure truncated. Fig. 23, Tetraedron. Fig. 24. Tetraedron, truncated on the angles. Fig. 25. Octaedron, having its common basis truncated. Fig. 26. Rectangular four-sided prism, acuminated by four planes, placed on the lateral planes. Fig. 27. Octaedron, having all its edges truncated. Fig. 28. Garnet dodecaedron, having the remains of the faces of the octaedron. Fig. 29. Garnet dodecaedron. Fig. 30. Octaedron, having each of its angles acuminated by four planes which are set on the lateral planes. Fig. 31. Same figure as the preceding, having the edges truncated. Fig. 32. Twin crystal.

SAPPHIRE.

Fig. 33. Double, three-sided pyramid. Fig. 34. Extremities of the pyramid deeply truncated. Fig. 35. Very deeply truncated. Fig. 36. Six-sided table. Fig. 37. Common basis of the pyramid truncated. Fig. 38. Six-sided prism, acuminated by three planes, which are placed on the alternate lateral edges, and the extremities of the acuminations slightly truncated. Fig. 39. Preceding figure, having its acuminations so deeply truncated that the remains of the truncating planes appear like truncations on the alternate angles. Fig. 40. Six-sided prism. Fig. 41. Six-sided table. Fig. 42. Six-sided prism, truncated on the edges and angles. Fig. 43. Preceding figure, only truncated on the terminal edges. Fig. 44. Six-sided prism, acuminated by six planes, set on the lateral planes, and the extremity of the acumination truncated. Fig. 45. Double six-sided pyramid. Fig. 46. Same figure, with its extremities truncated. Fig. 47. Same more deeply truncated. Fig. 48. Same figure, in which the alternate angles, formed by the meeting of the truncating plane and the acuminating planes are truncated. Fig. 49. Acute, single six-sided pyramid, having its lateral edges truncated. Fig. 50. Single six-sided pyramid. Fig. 51. Single six-sided pyramid, in which the alternate and alternating angles are slightly truncated. Fig. 52. Acute six-sided pyramid, flatly acuminated by three planes, which are set on the alternate lateral edges.

PRECIOUS BERYLL.

Fig. 53. Six-sided prism, with truncated lateral edges. Fig. 54. Same figure, with truncated angles. Fig. 55. Six-sided prism, acuminated by six planes, which are placed on the lateral planes, and the extremities

tremities of the acuminations deeply truncated. Fig. 56. Six-sided prism, having terminal edges and angles truncated.

TOURMALINE.

Fig. 57. Equiangular three-sided prism, acuminate on both extremities by three planes, which on one extremity are set on the lateral planes, on the other on the lateral edges; and the lateral edges are so deeply bevilled, that it appears like a nine-sided prism. Fig. 58 Flat, double three-sided pyramid, in which the alternate angles, the common basis, and all the edges, are truncated.

THUMERSTONE.

Fig. 59. Very oblique rhomb, in which the two opposite obtuse lateral edges are truncated.

ROCK CRYSTAL.

Fig. 60. Equiangular six-sided prism, somewhat acutely acuminate on both extremities by six planes, which are set on the lateral planes. Fig. 61. Double six-sided pyramid.

PREHNITE.

Fig. 62. Oblique four sided table. Fig. 63. Same figure, truncated on the acute edges. Fig. 64. Flat four-sided prism, bevilled on both extremities, the bevilling planes set on the smaller lateral planes, and the edge of the bevillment truncated.

RADIATED ZEOLITE.

Fig. 65. Broad rectangular four-sided prism, acutely acuminate by four planes, which are set on the lateral edges, and the extremities of the acuminations slightly truncated.

Fig. 66. Four-sided prism, flatly acuminated by four planes which are set on the lateral planes.

FOLIATED ZEOLITE.

Fig. 67. Short and oblique four-sided prism, in which the acute edges, and angles on the obtuse edges are truncated. Fig. 68. Six-sided prism, truncated on all its angles.

CUBIC ZEOLITE.

Fig. 69. Cube. Fig. 70. Cube, acuminated on each of its angles by three planes, which are set on the lateral planes. Fig. 71. Acute double eight-sided pyramid, acuminated on each extremity by four planes, which are placed on the alternate and alternating lateral edges.

CROSS STONE.

Fig. 72. Broad rectangular four-sided prism, acuminated by four planes, which are set on the lateral edges.

Fig. 73. Twin crystal, formed by the intersection of two of the preceding.

FELSPAR.

Fig. 74. Broad six-sided prism, bevelled on both extremities, the bevelling planes set on the edges formed by the meeting of the smaller lateral planes.

Fig. 75. Very oblique four-sided prism, flatly bevelled on both extremities, the bevelling planes set on the obtuse lateral edges.

MICA.

Fig. 76. Equilateral six-sided table.

BASALTIC HORNBLENDE.

Fig. 77. Equilateral six-sided prism, acuminated on both extremities by three planes which on one extremity are set on the lateral edges, on the other on the lateral planes: Fig. 78. Six-sided prism, flatly acuminated on one extremity by four planes which are set on the lateral planes, on the other bevilled, the bevilling planes set on the two opposite lateral edges: Fig. 79. Six-sided prism, on one extremity flatly acuminated by three planes which are set on the lateral edges, on the other bevilled, the bevilling planes set on the two opposite edges:

CALC SPAR.

1. *Six-sided Pyramid.*

Fig. 80. Double six-sided pyramid, in which the lateral planes of the one are obliquely set on the lateral planes of the other, in such a manner that the edges of the common basis form a zig-zag line, and the more obtuse lateral edges of the one are opposed to the less obtuse lateral edges of the other pyramid.

Fig. 81. Preceding figure, acuminated by three planes, which are placed on the alternate and obtuse lateral edges.

Fig. 82. Acute, double, six-sided pyramid, acutely acuminated, and the acuminating planes set on the alternate and less obtuse lateral edges.

Fig. 83. is fig. 80. whose extremities are very deeply truncated, and the angles on the common basis also truncated. Fig. 84. Preceding figure, in which the truncations of the angles of the basis have increased, so much that it forms the passage to the next figure.

2. *Six-sided Prism.*

Fig. 85. Six sided prism, acuminated by six planes, which are set on the lateral edges. Fig. 86 Preceding figure, in which the acumination is again acuminated by three planes which are set on the alternate edges. Fig. 87. Six-sided prism, rather flatly acuminated by three planes, which are placed on the alternate lateral edges. Fig. 88 Perfect six-sided prism. Fig. 89. Preceding figure, truncated on the lateral edges.

3. *Three-sided Pyramid.*

Fig. 90. Obtuse, double three-sided pyramid, in which the lateral planes of the one are set on the lateral edges of the other. Fig. 91. Preceding figure, in which the lateral edges are truncated. Fig. 92. The extremities of the pyramids deeply truncated. Fig. 93. Acute double three-sided pyramid. Fig. 94. The extremities of the preceding figure truncated. Fig. 95. Acute double three-sided pyramid, slightly and acutely acuminated by three planes, which are set on the lateral edges. Fig. 96. Acute, double, three sided pyramid, in which the lateral edges are bevilled. Fig. 97. Preceding figure, in which the edges of the bevillment are truncated.

APPATITE.

Fig. 98. Low, equiangular six sided prism. Fig. 99. Rather longer six-sided prism, with truncated lateral edges. Fig. 100. Six sided prism, with truncated terminal edges. Fig. 101. Six-sided prism, in which both terminal and lateral edges are truncated. Fig. 102. is fig. 100. in which the angles are truncated.

ASPARAGUS OR SPARGEL STONE.

Fig. 103. Equilateral six-sided prism, acuminated by six planes, which are set on the lateral planes. Fig. 104. Same figure as the preceding, but having the lateral edges truncated.

BORACITE.

Fig. 105. Cube, having its edges and angles truncated.

FLUOR SPAR.

Fig. 106. Cube. Fig. 107. Cube, with truncated edges. Fig. 108. Garnet dodecaedron. Fig. 109. Cube, deeply truncated on the angles, passing to the following figure: Fig. 110. Octaedron. Fig. 111. Octaedron, truncated on the edges. Fig. 112. Cube, with bevelled edges. Fig. 113. Cube having each plane divided into four.

SELENITE.

Fig. 114. Pretty oblique six-sided prism, having two opposite planes larger, and four opposite smaller, and rather flatly bevelled on both extremities, the bevilling planes set obliquely, yet parallelly on the broader lateral planes, so that it has a rhomboidal aspect. Fig. 115. Rhomboidal crystal. Fig. 116. is fig. 114. acuminated on both extremities by four planes which are set on the lateral edges that bound the two larger planes.

STRAIGHT LAMELLAR HEAVY SPER.

Fig. 117. Oblique four-sided table, having its obtuse angles truncated. Fig. 118. Six-sided table. Fig. 119. Rectangular four-sided table, having all its terminal planes bevelled. Fig. 120. Preceding figure, in which the angles are truncated.

PRISMATIC

PRISMATIC HEAVY SPAR.

Fig. 121. Oblique, four-sided prism, bevelled on both extremities, the bevilling planes set on the acute lateral edges.

CELESTINE.

Fig. 122. Oblique four-sided prism, bevelled on both extremities, the bevilling planes set on the acute lateral edges. Fig. 122. Preceding figure, truncated on the lateral edges. Fig. 123. Oblique four-sided prism, acuminated by four planes, which are set on the lateral edges, and the acuminating planes ending in a line. Fig. 124. Six-sided table.

PLATE II.

In giving an account of the crystallizations of a mineral, we mention its fundamental figure or figures, describe their varieties, and arrange them according to their natural alliances. Colour, which is a very important character, must also be treated in a similar manner; the species and varieties must be correctly determined, and arranged according to their affinities with each other, otherwise, particularly in minerals possessing extensive suites of colour, as diamond and sapphire, it would be very difficult to recollect them, and when remembered would not convey to the mind a very distinct picture of this highly interesting character. I have, therefore, been careful in the descriptions to determine the colours with precision, and to arrange them as much as possible in a natural order. In the treatise of Hauy, the colours are not arranged, and very seldom accurately determined; this is the case, although not in so great a degree, with a more useful work, the Mineralogy of Brochant.

In plate 11. I have represented the colour suite of diamond and sapphire, in which the numerous species and varieties of colour are arranged according to their relations to each other. It would be useful to have similar plans of each species.

THE END.

In the first place, the fact that the
 majority of the people of the United States
 are not in favor of the proposed
 amendment is a strong argument
 against its adoption. It would be
 a mistake to suppose that the
 people of the United States are
 in favor of the proposed
 amendment.

THE END

DIAMOND.

Fig. 1.

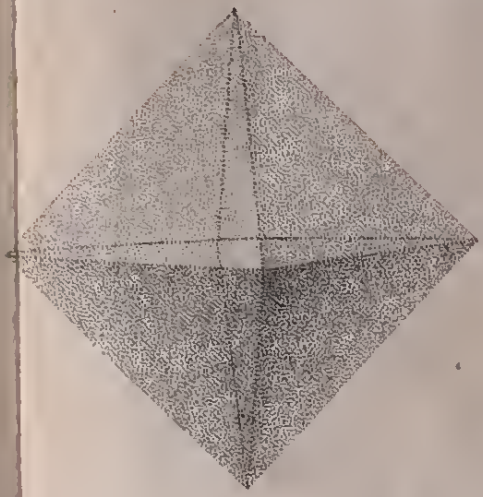

Fig. 2.

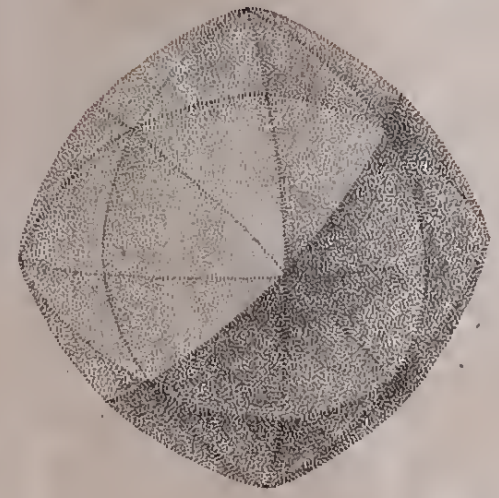
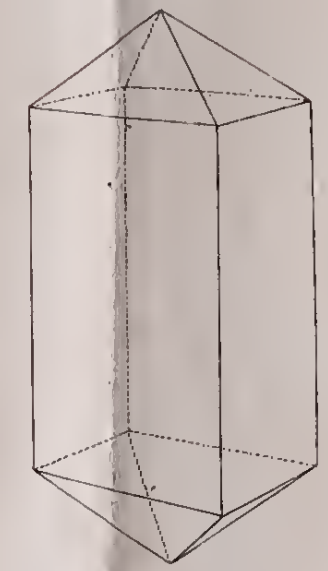

Fig. 3.



ZIRCON.

Fig. 4.

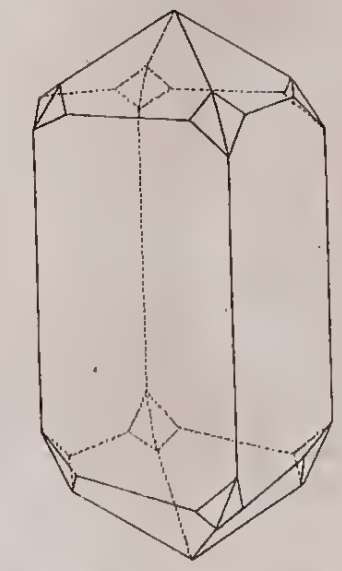
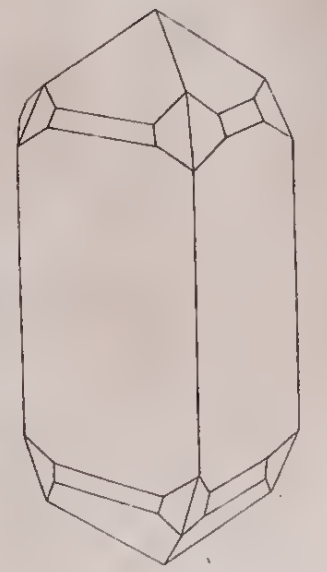
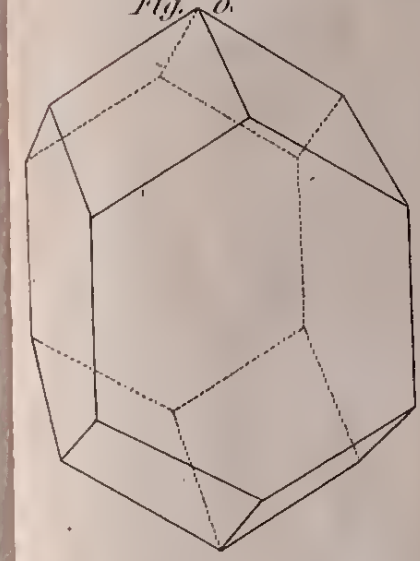

Fig. 5.



HYACINTH.

Fig. 6.



CHRYSOBERYLL.

Fig. 7.

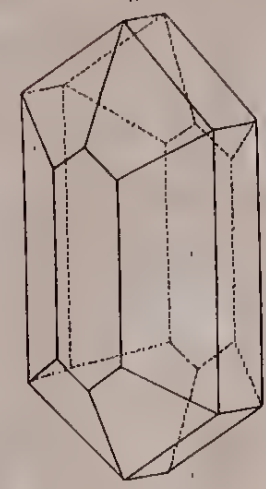
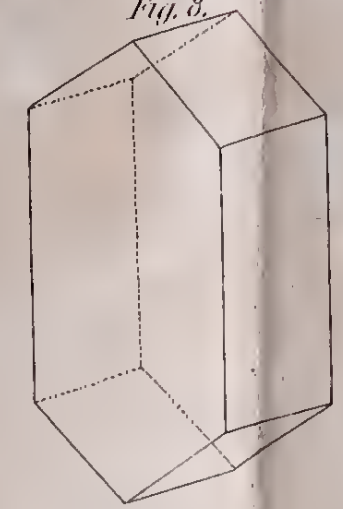
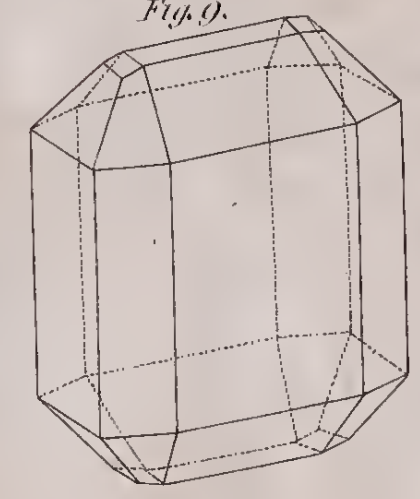

Fig. 8.



CHRYSOLITE.

Fig. 9.



AUGITE.

Fig. 10.

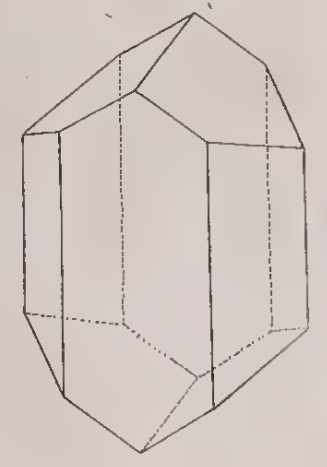
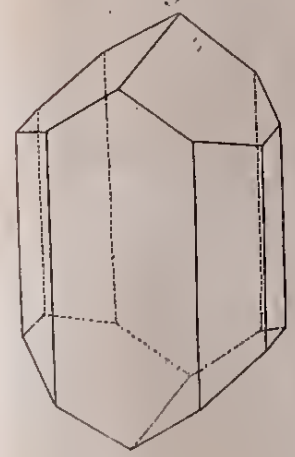

Fig. 11.



GARNET.

Fig. 14.

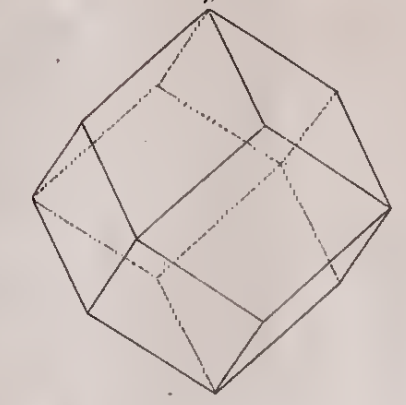
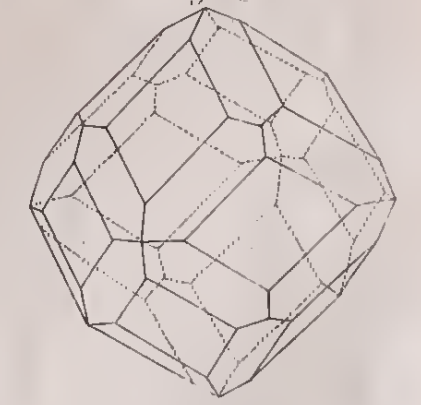

Fig. 15.



URSUVIANE.

Fig. 12.

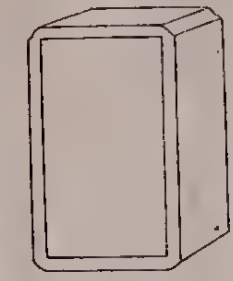
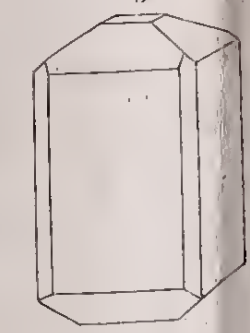
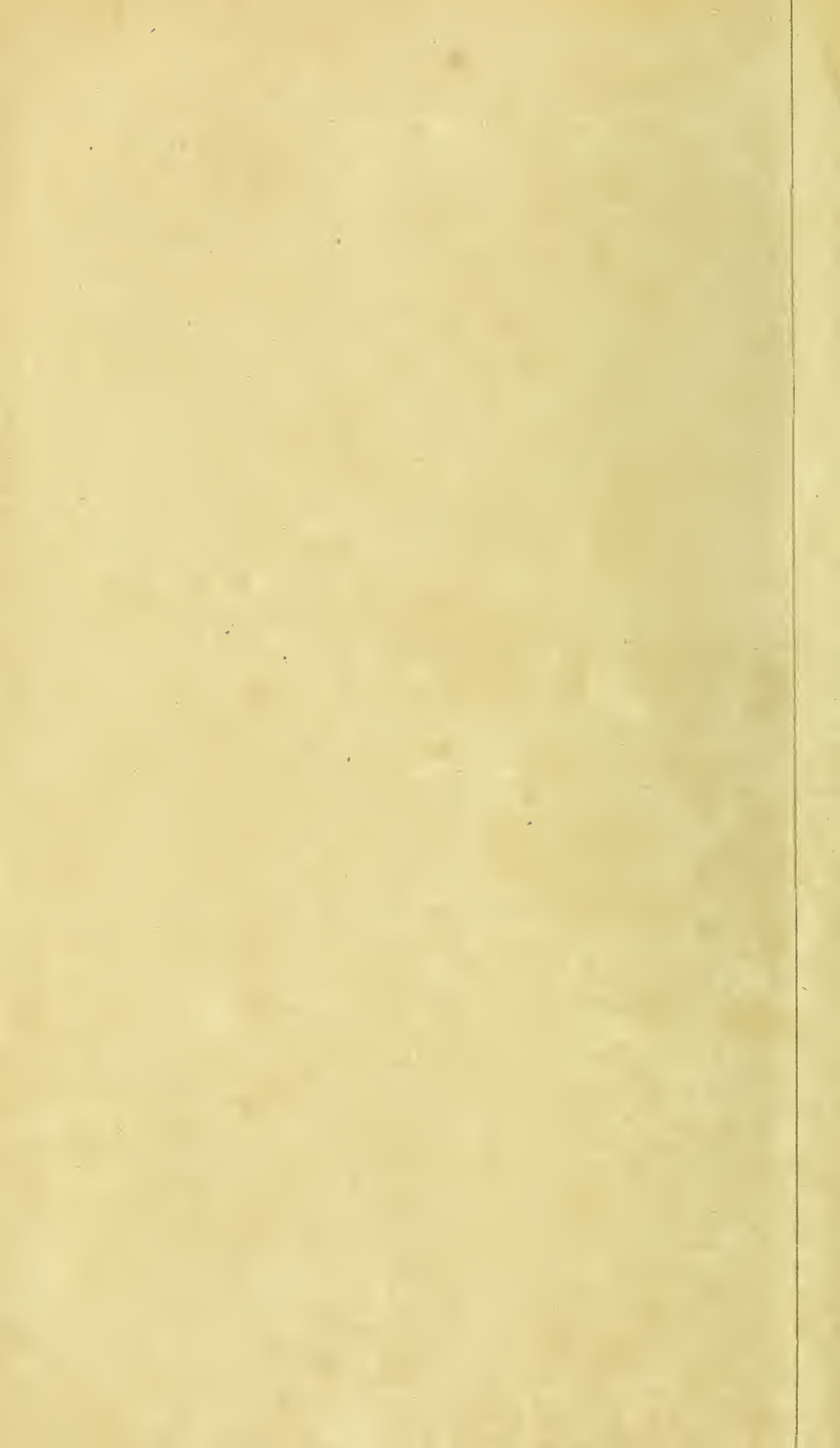

Fig. 13.





GARNET.

GRANATITE.

SPINELLE.

PLATE II

Fig. 16.

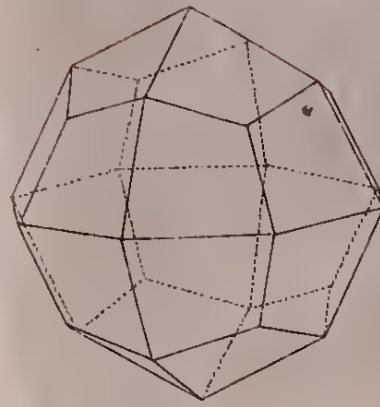

Fig. 17.

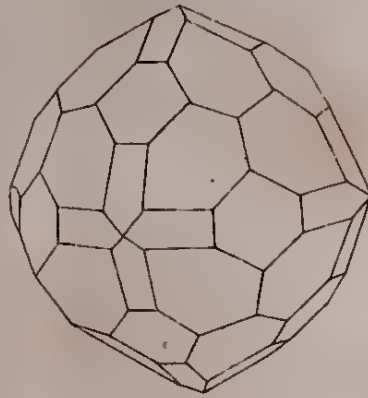

Fig. 18.

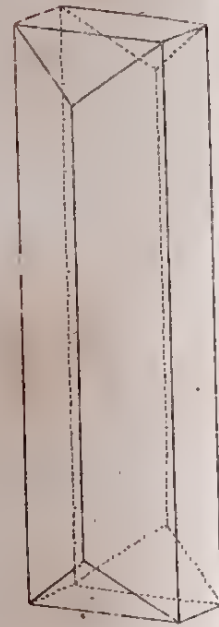

Fig. 19.

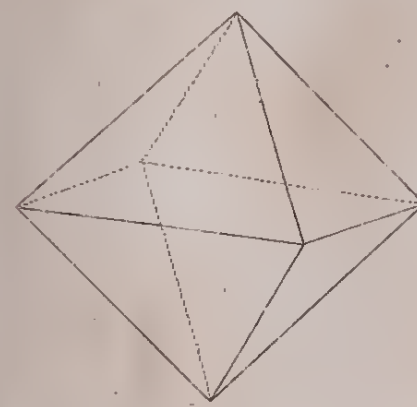

Fig. 20.



Fig. 21.

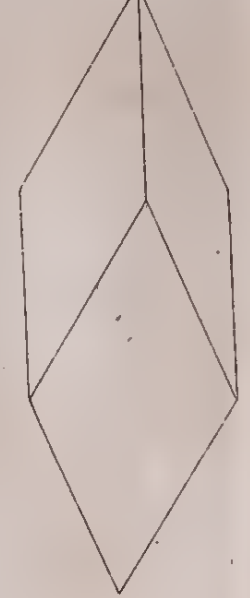

Fig. 22.



Fig. 23.

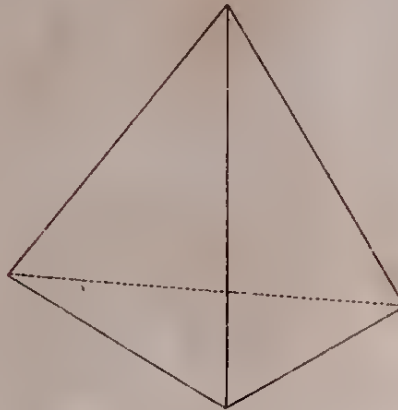

Fig. 24.

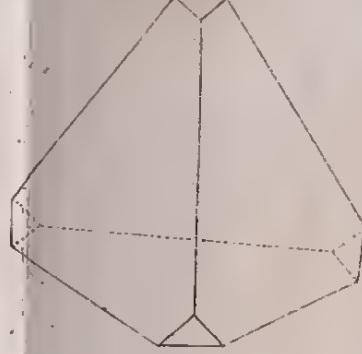

Fig. 25.

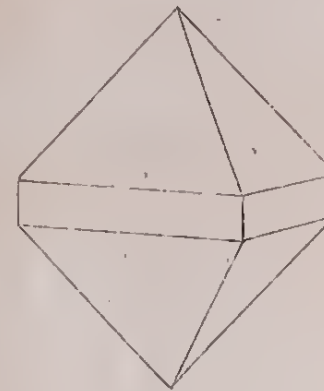

Fig. 26.

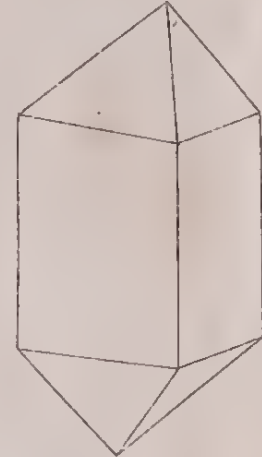

Fig. 27.

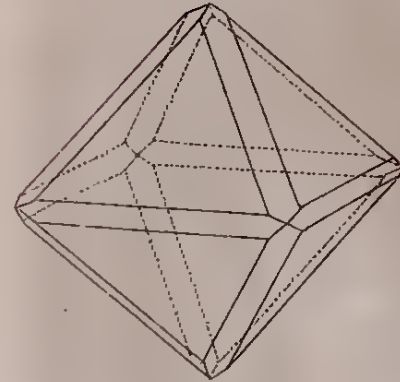

Fig. 28.

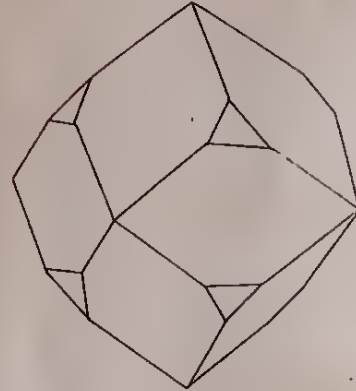

Fig. 29.

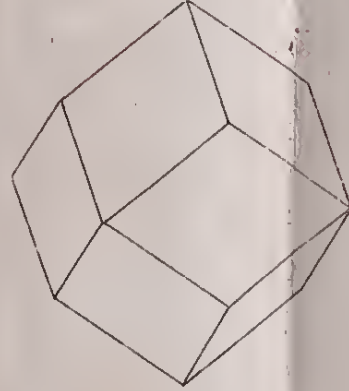

Fig. 30.

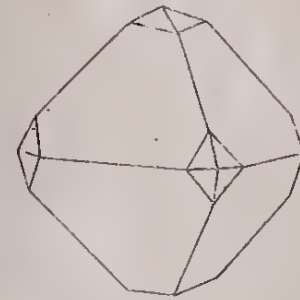

Fig. 31.

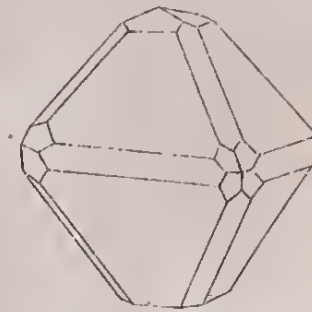
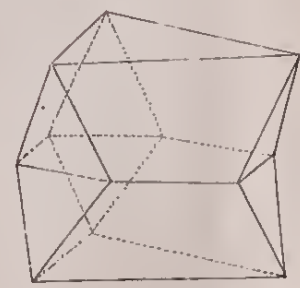
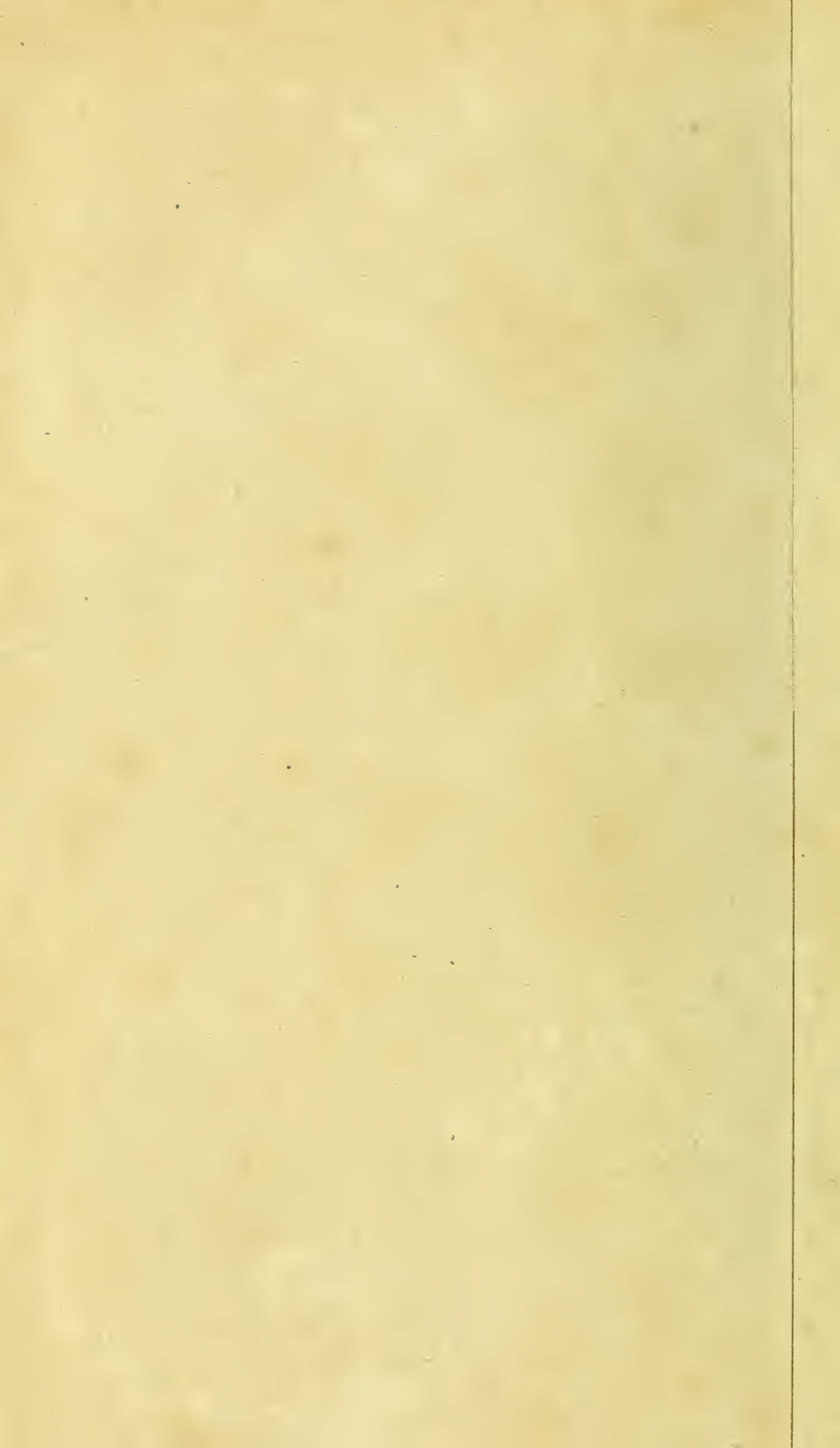

Fig. 32.





SAPPHIRE.

Fig. 33.

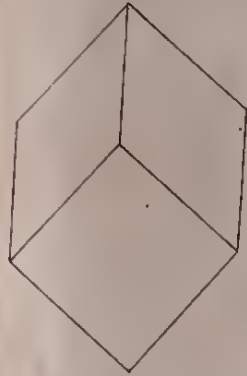

Fig. 34.

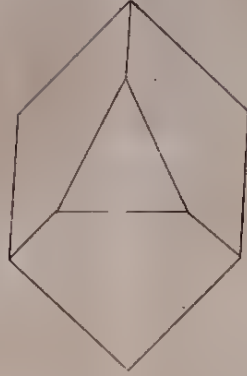

Fig. 35.

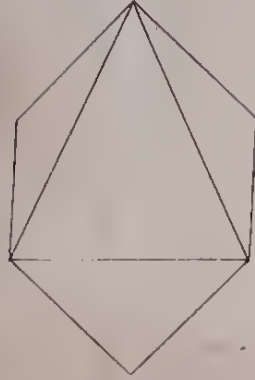

Fig. 36.

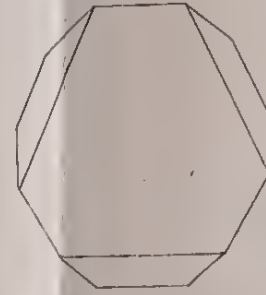

Fig. 37.

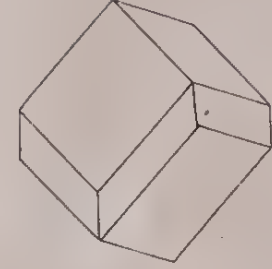

Fig. 38.



Fig. 39.

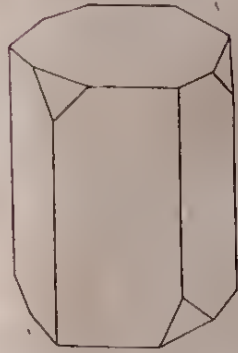

Fig. 40.



Fig. 41.



Fig. 42.

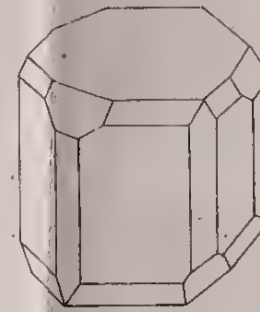

Fig. 43.

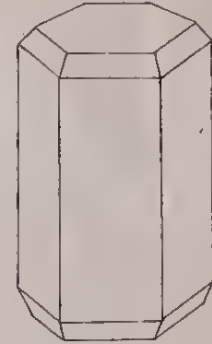

Fig. 44.

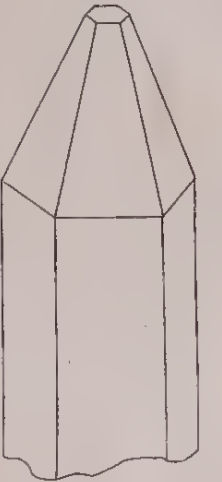

Fig. 47.

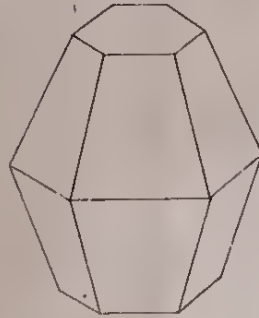

Fig. 45.

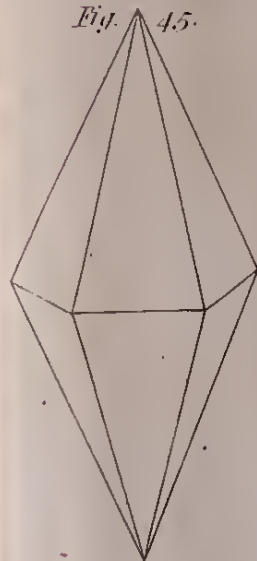

Fig. 46.

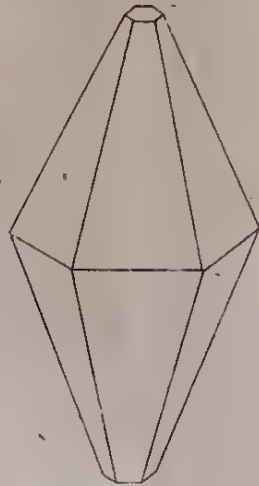

Fig. 48.

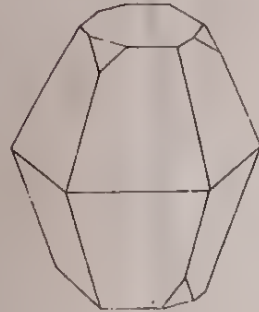

Fig. 49.



Fig. 50.

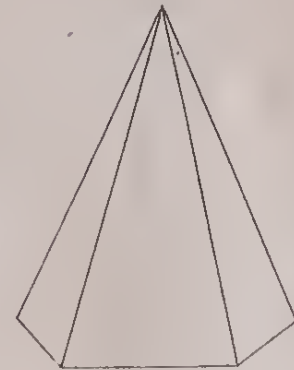
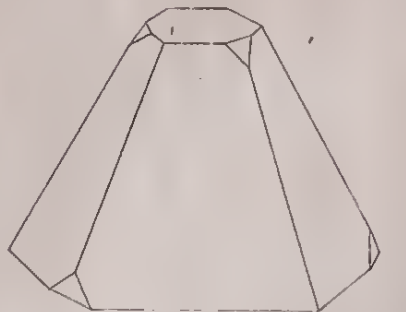
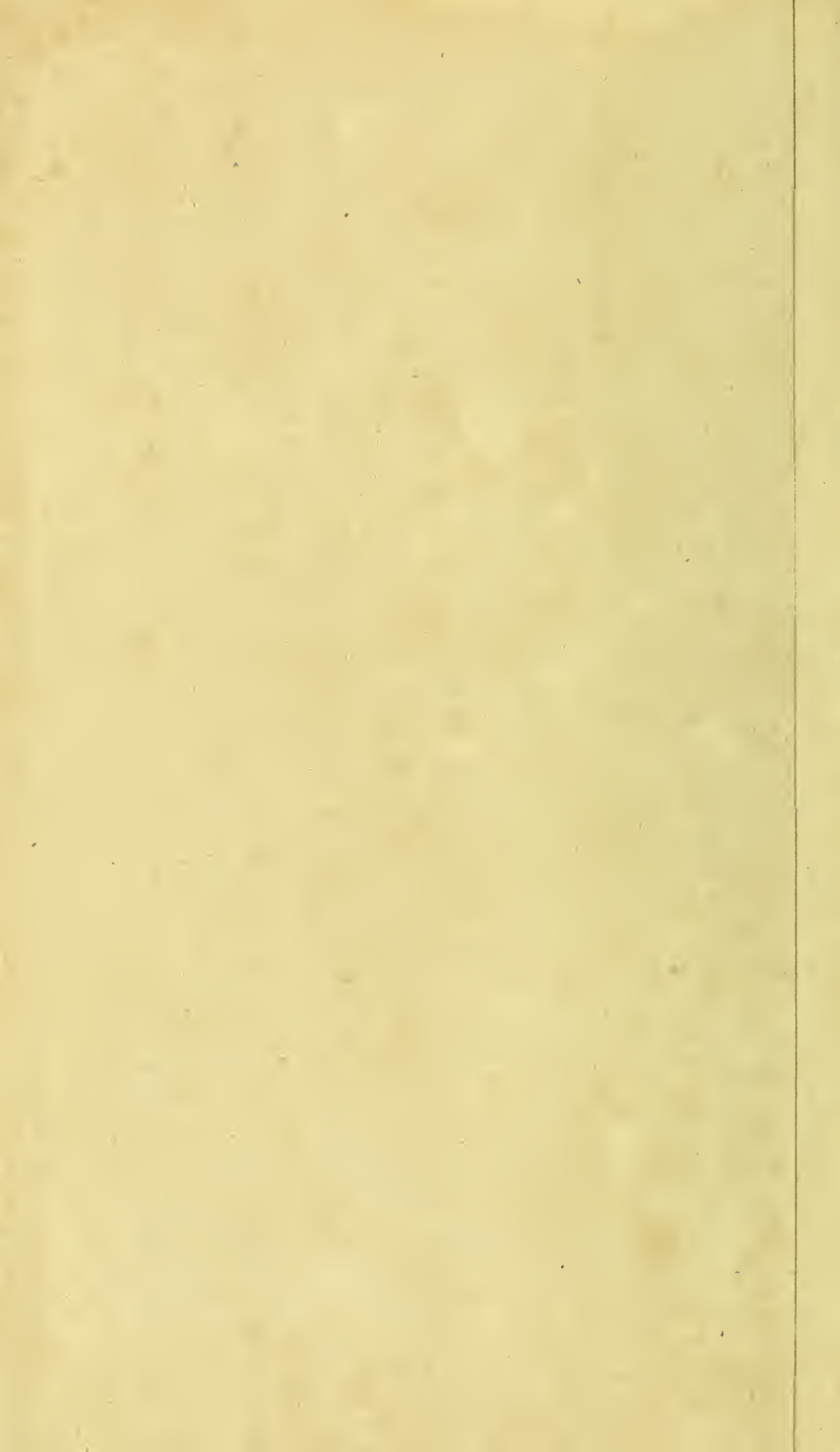
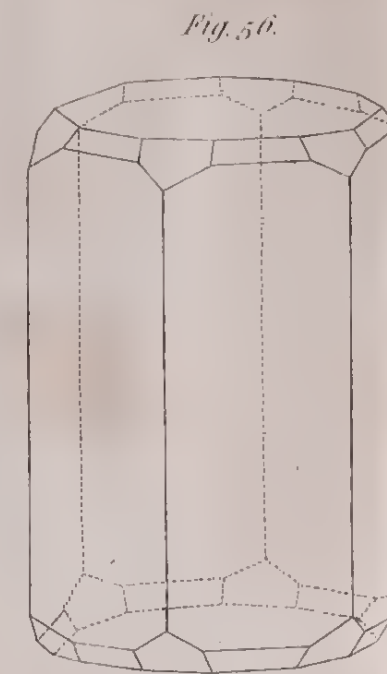
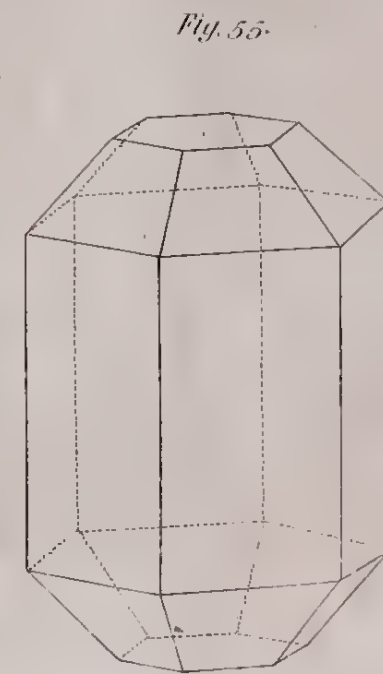
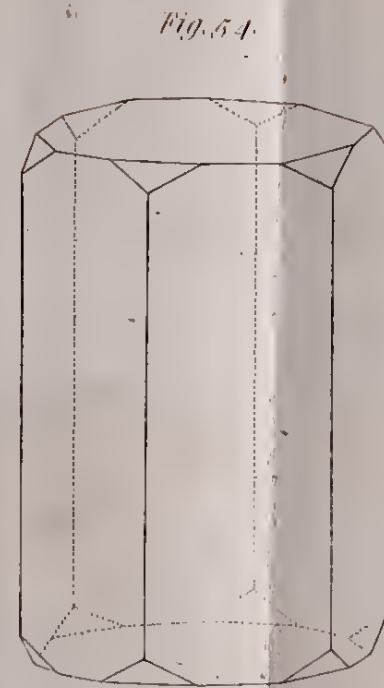
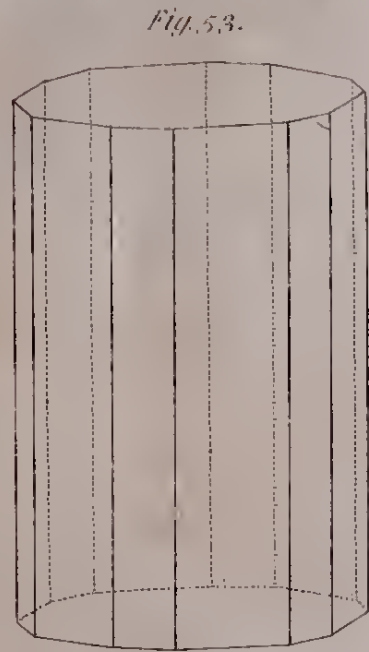
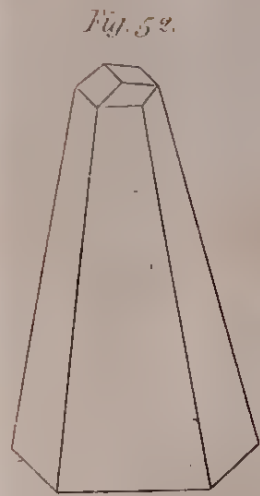

Fig. 51.





PRECIOUS BERYLL.



TOURMALINE.

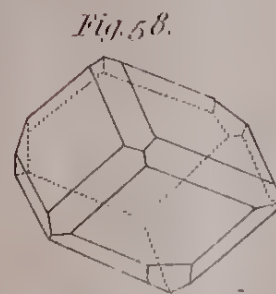
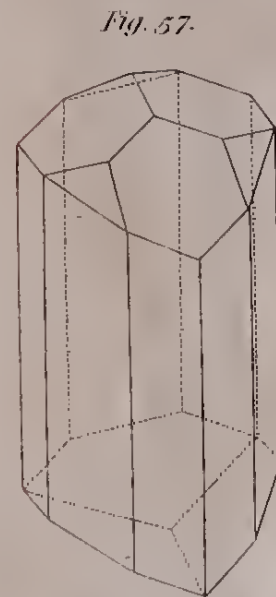

THUMERSTONE.

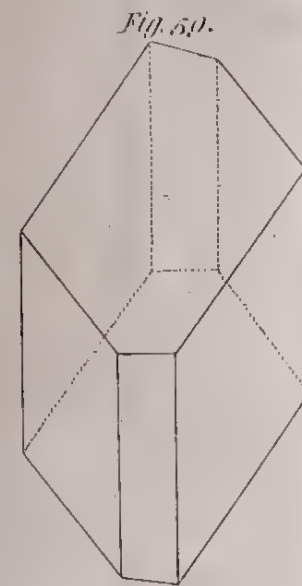

ROCK CRYSTAL.

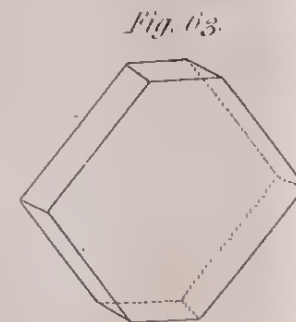
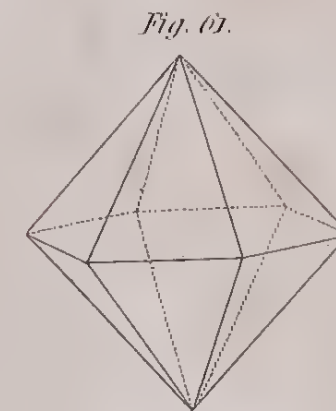
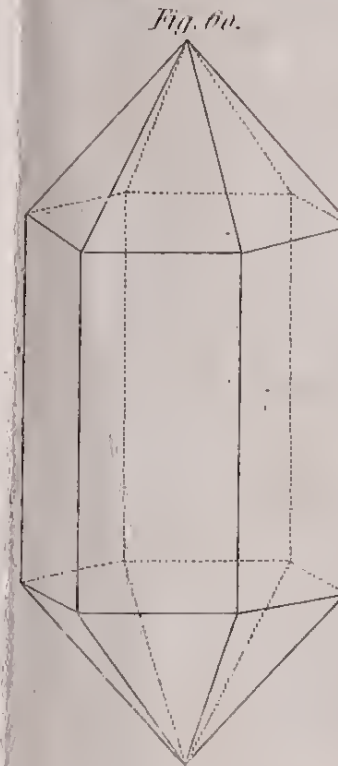

EMERALD.

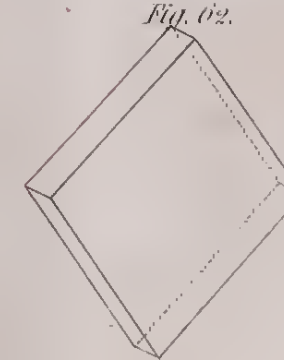

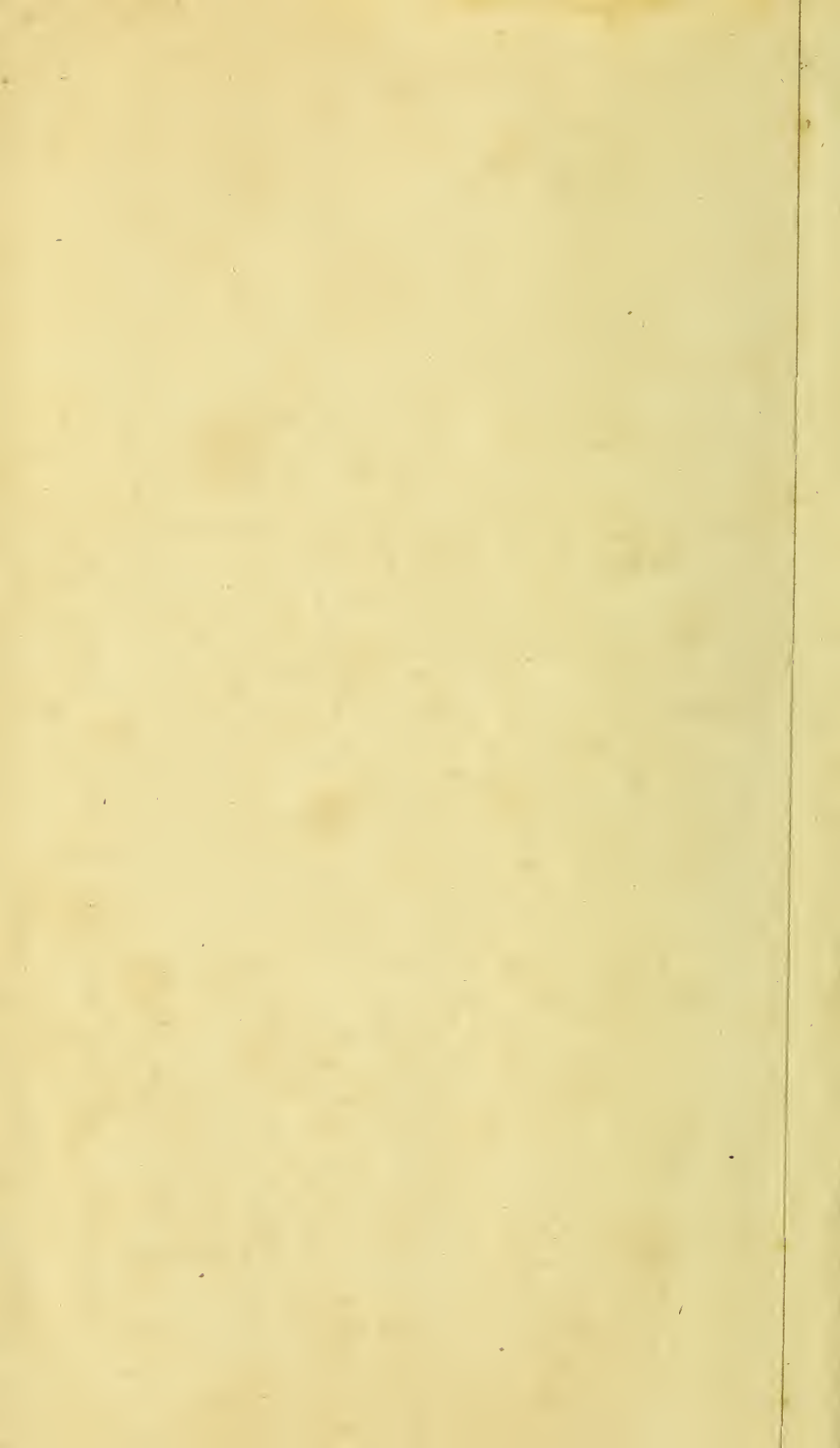

RADIATED ZEOLITE.

FOLIATED ZEOLITE.

CUBIC ZEOLITE.

Fig. 65.

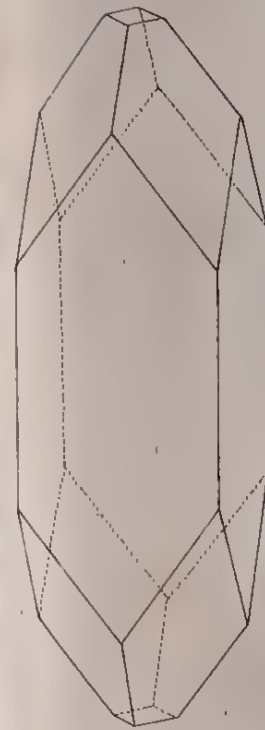

Fig. 66.



Fig. 67.

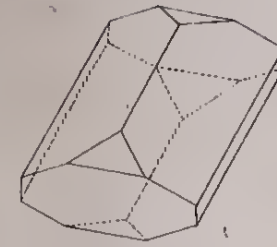

Fig. 68.

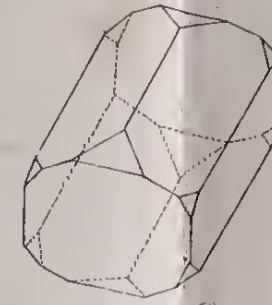

Fig. 69.

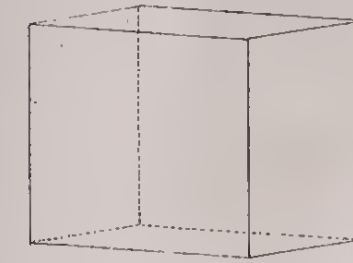
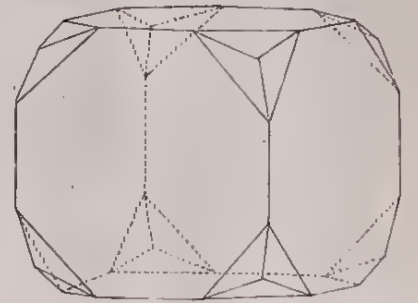

Fig. 70.



CROSS STONE.

FRI. SPAR.

Fig. 72.



Fig. 73.

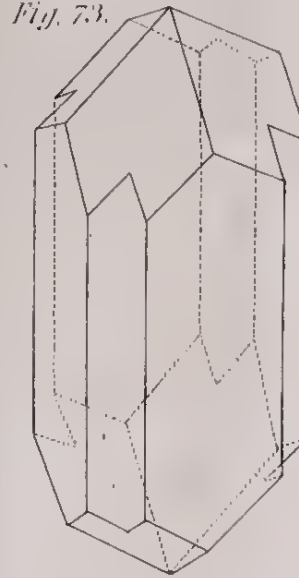

Fig. 71.

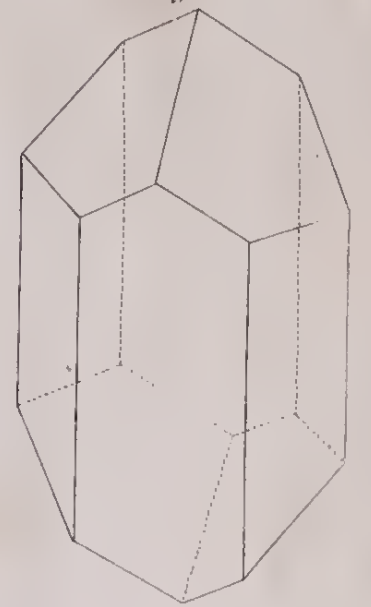
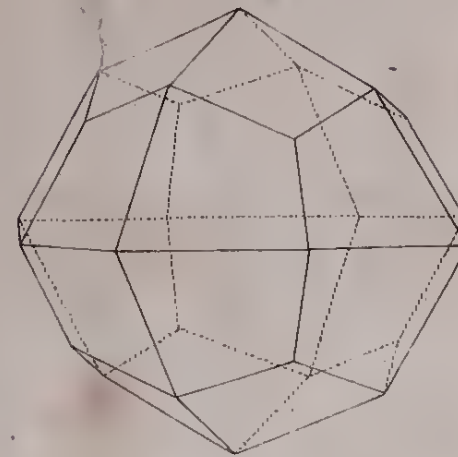

Fig. 71.



BASALTIC HORNBLENDE.

Fig. 75.

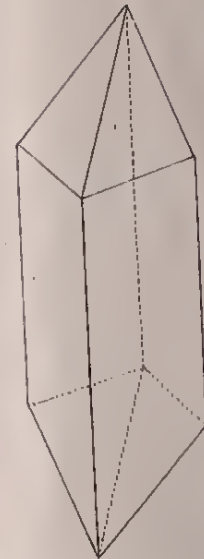

Fig. 77.



Fig. 78.

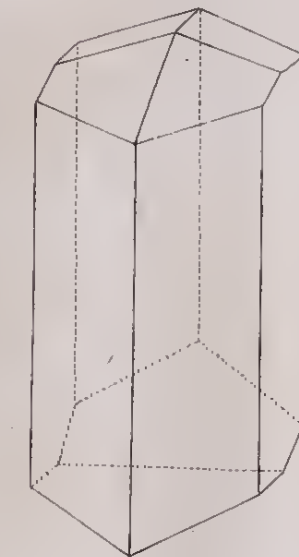
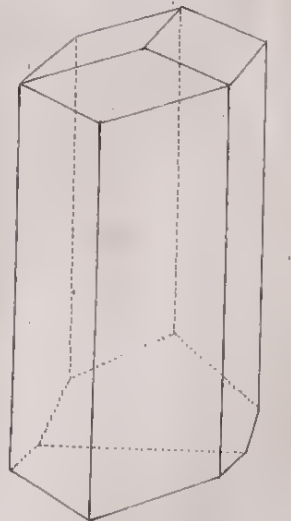

Fig. 79.



MICA.

Fig. 76.



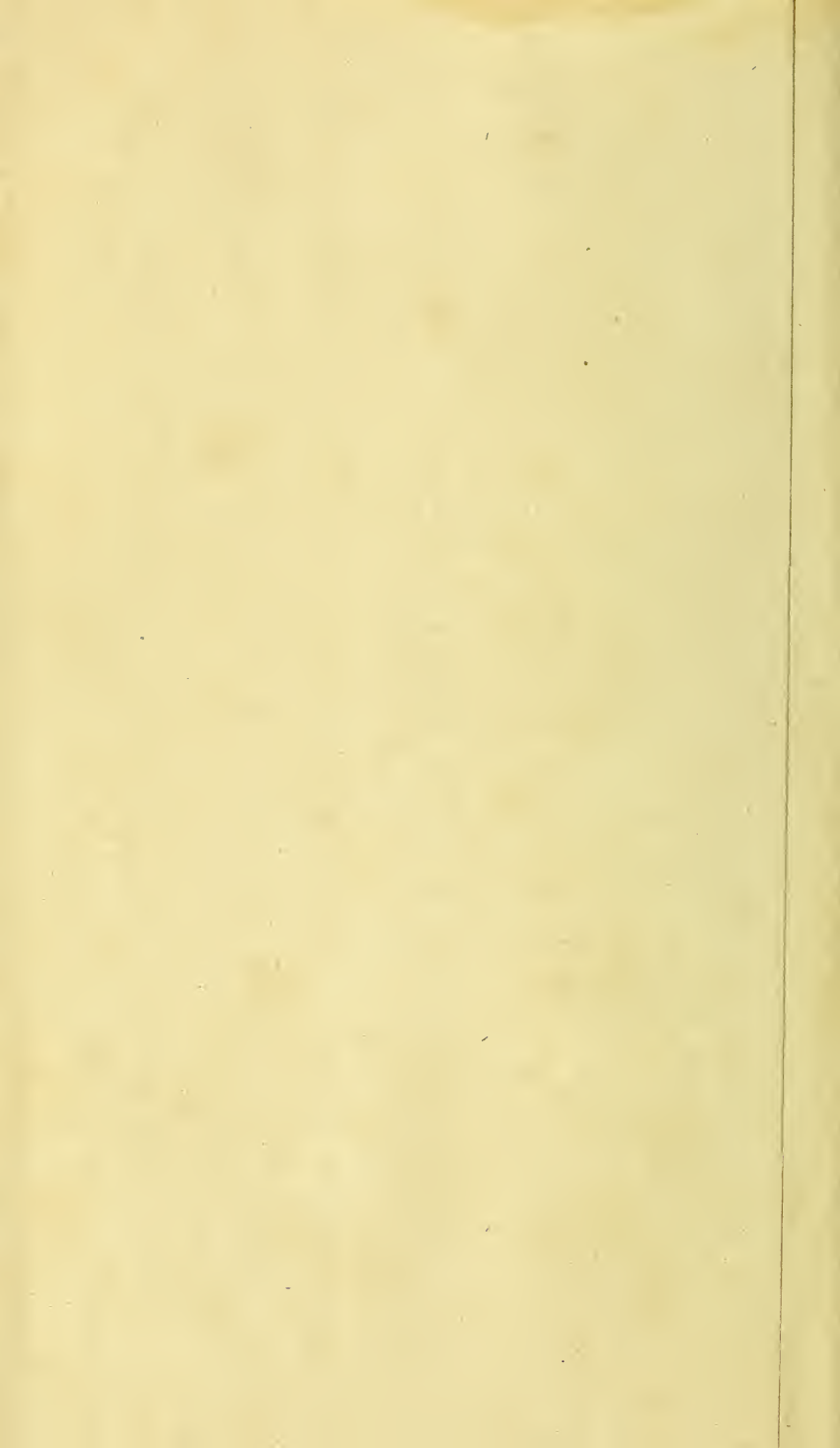

CLAY-C-SPAR.

Fig. 80.

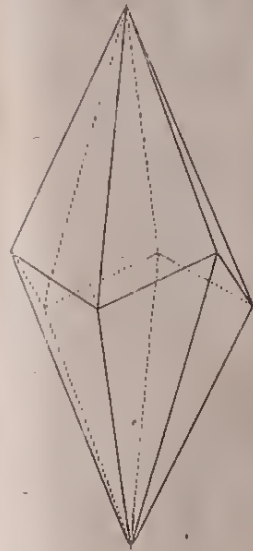

Fig. 81.

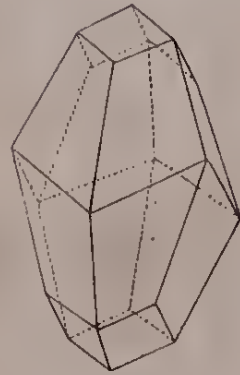

Fig. 82.

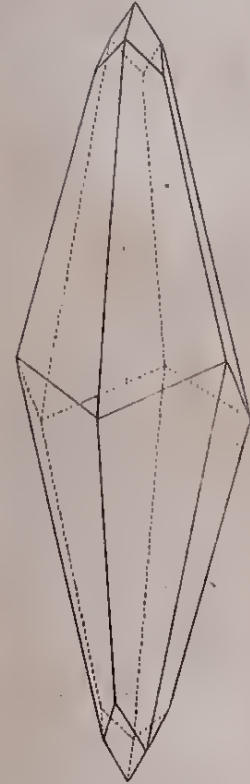

Fig. 83.



Fig. 84.

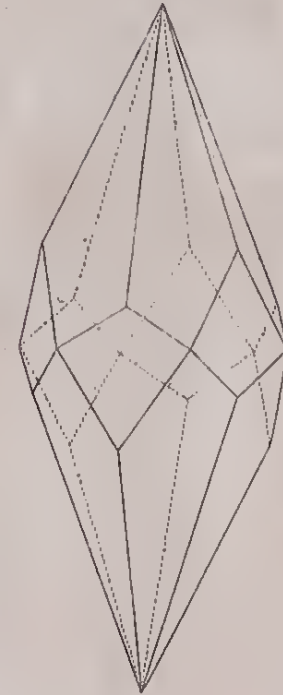

Fig. 85.

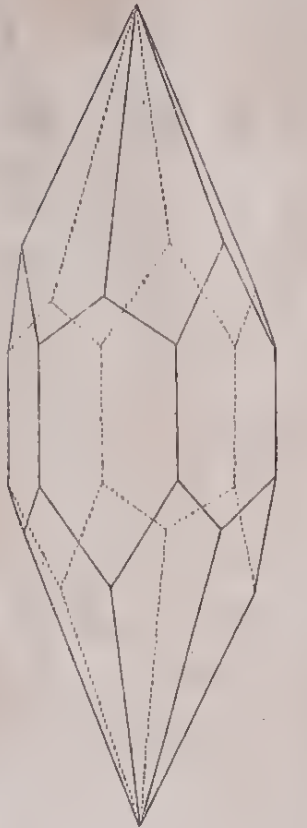

Fig. 86.

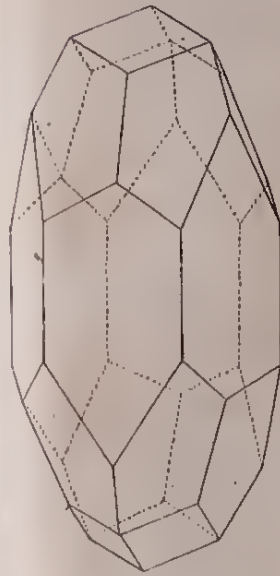

Fig. 87.



Fig. 88.



Fig. 89.



Fig. 90.

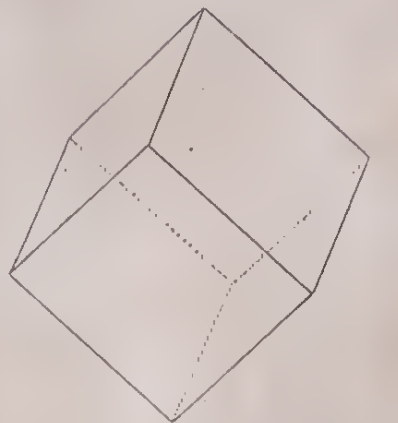

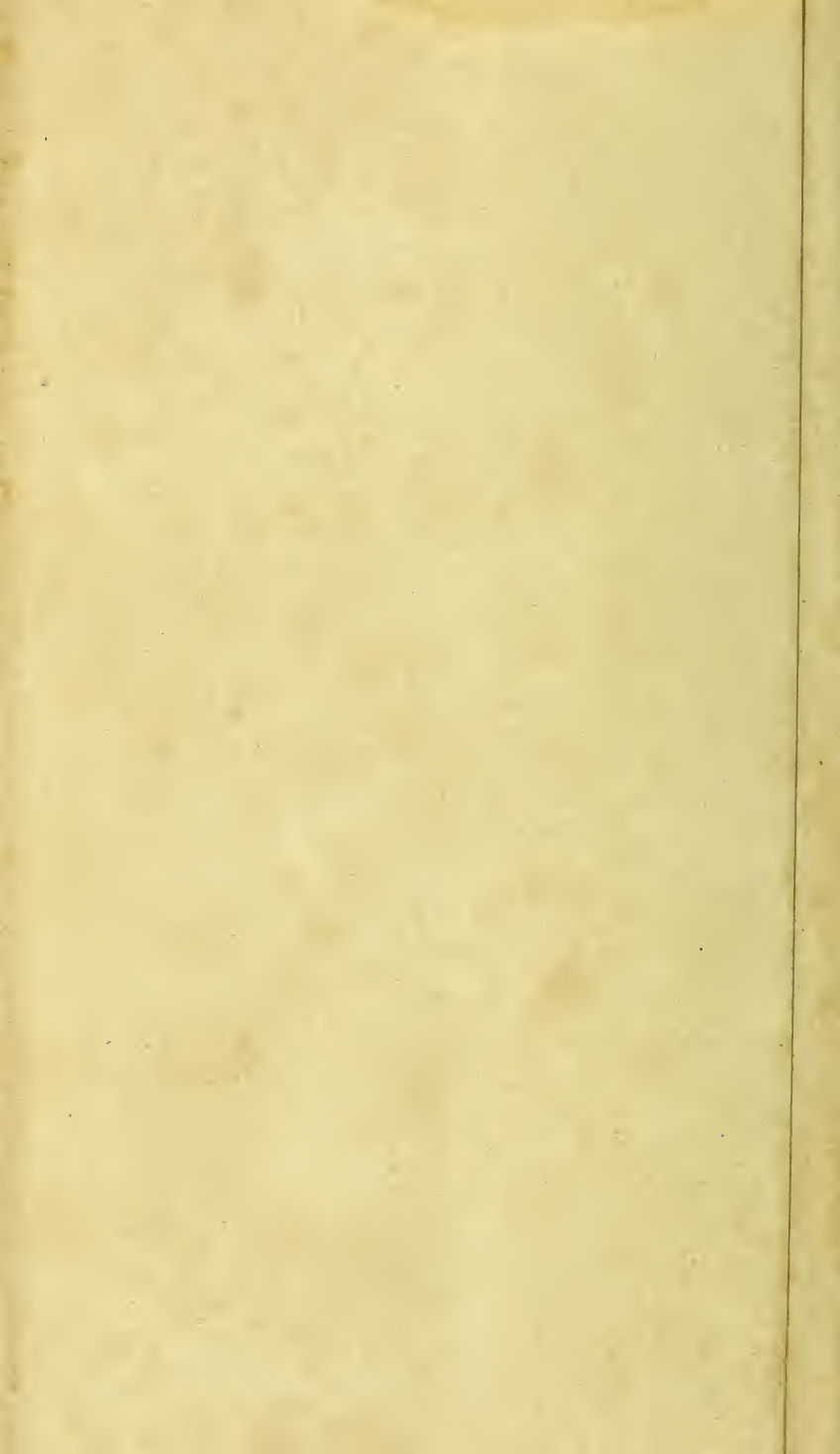

Fig. 91.



Fig. 92.

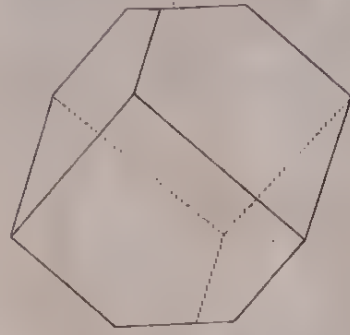

Fig. 93.

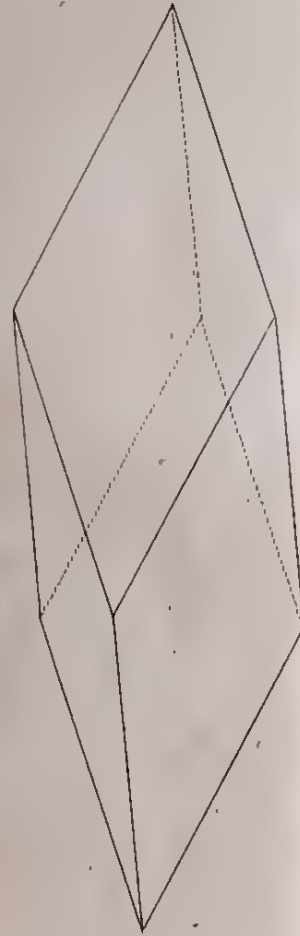

Fig. 94.

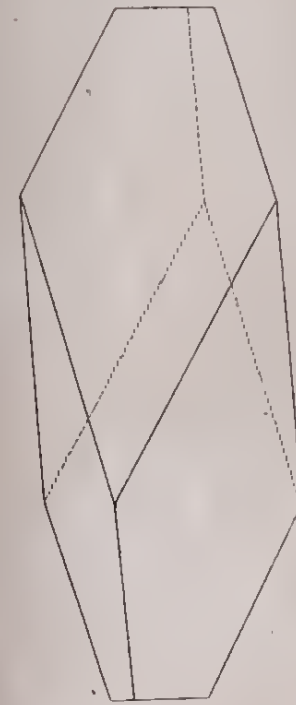

Fig. 95.



Fig. 96.



Fig. 97.

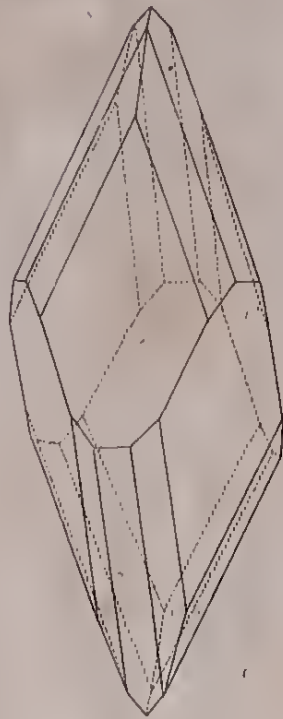

APPATITE.
Fig. 98.

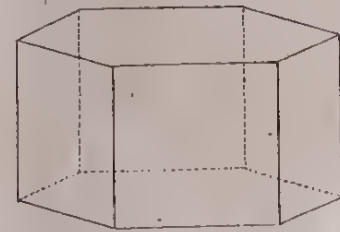

Fig. 99.

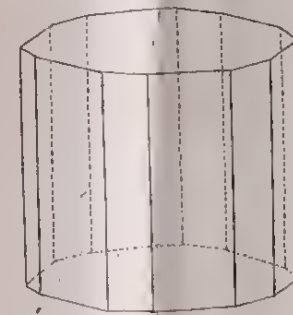

Fig. 100.

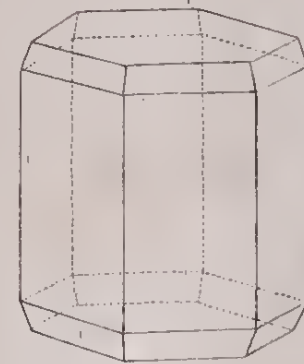
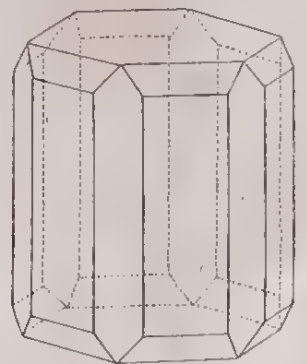
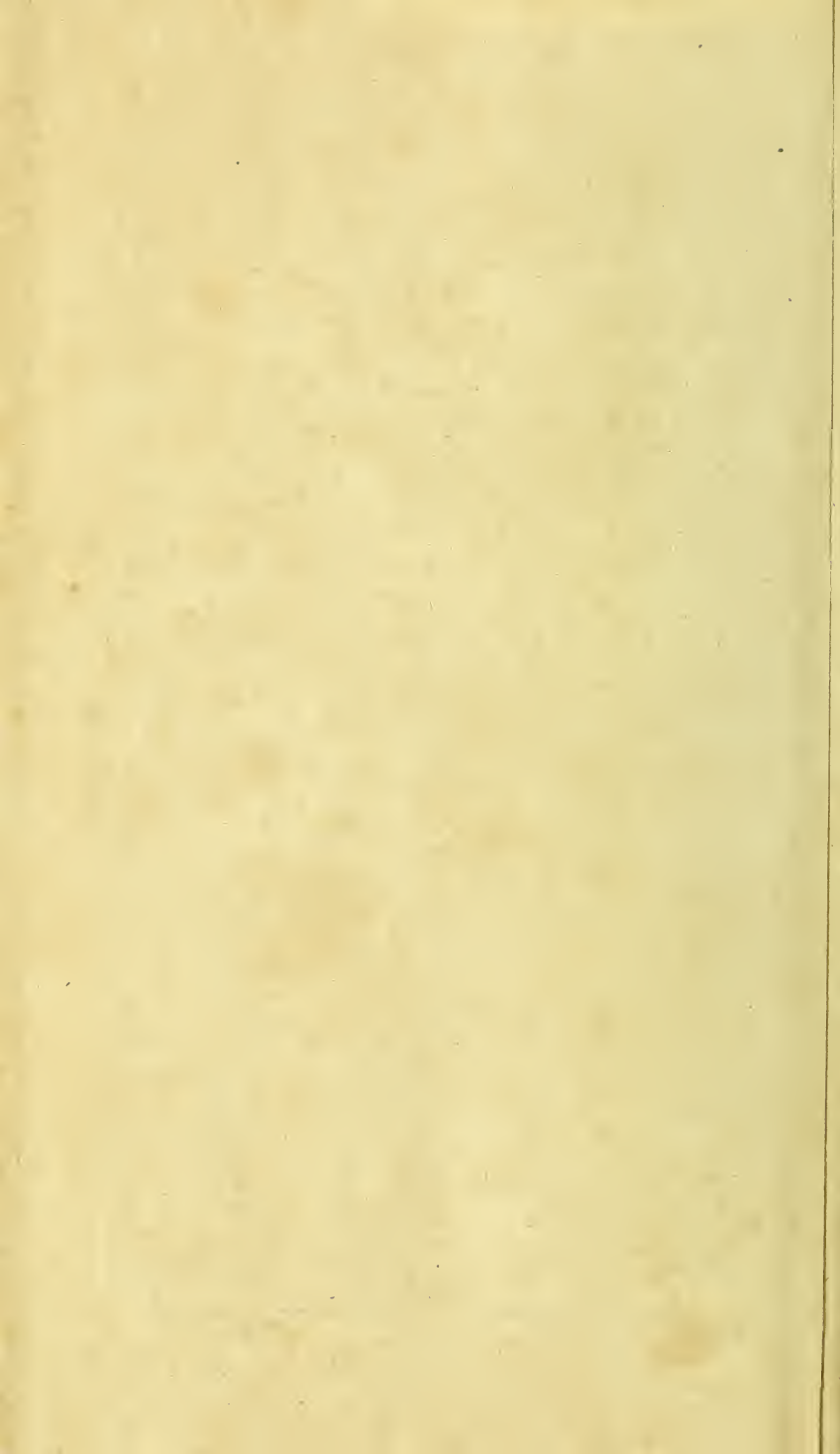

Fig. 101.





ASPARAGUS STONE.

BORACITE.

FLUOR SPAR.

Fig. 102.

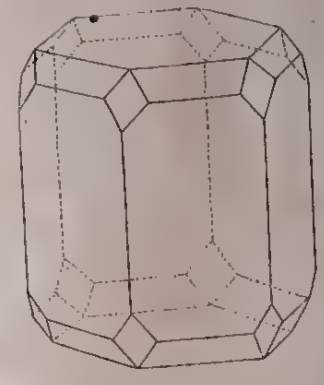

Fig. 103.

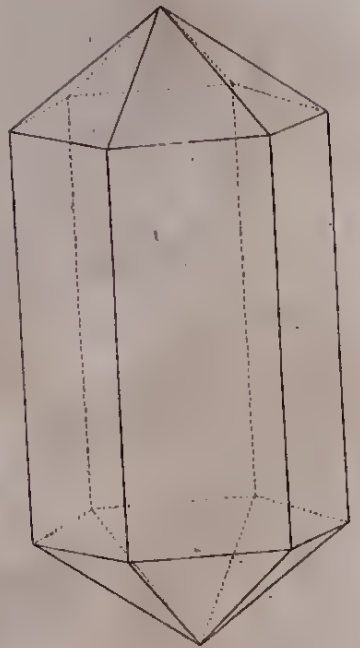

Fig. 104.

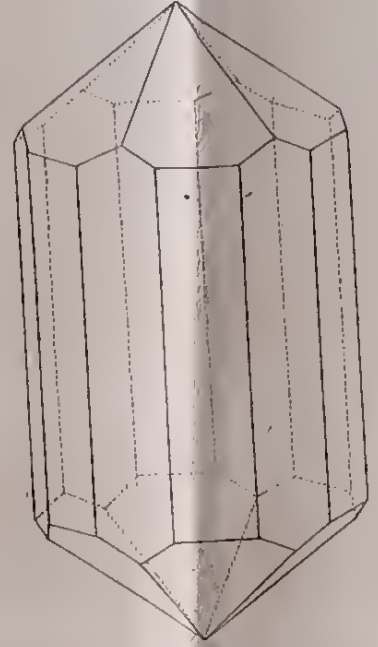

Fig. 105.

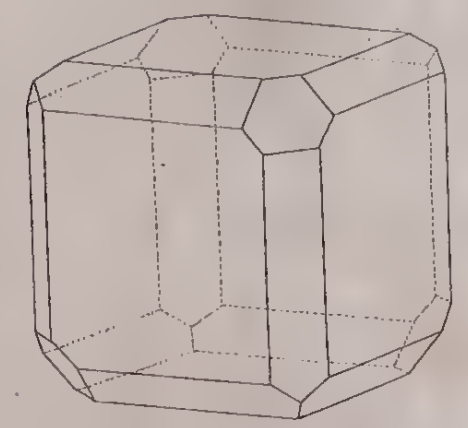

Fig. 106.

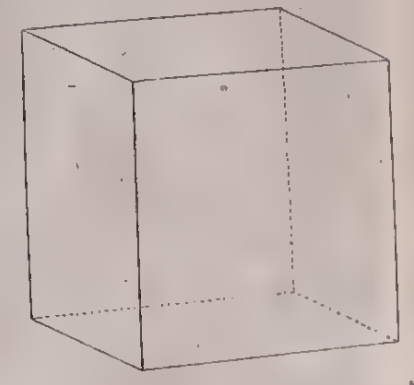

Fig. 110.

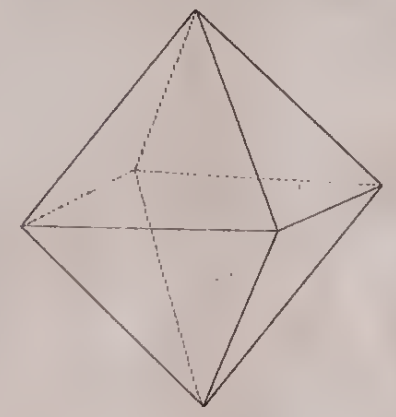

Fig. 111.

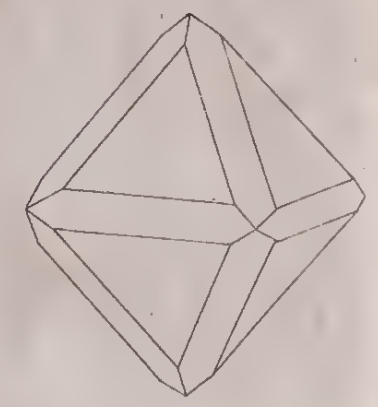

Fig. 107.

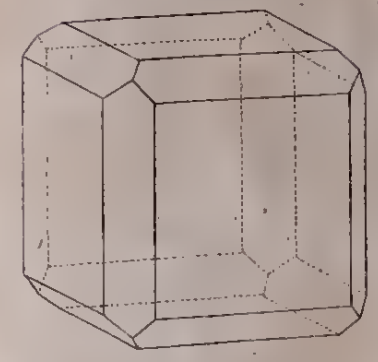

Fig. 108.

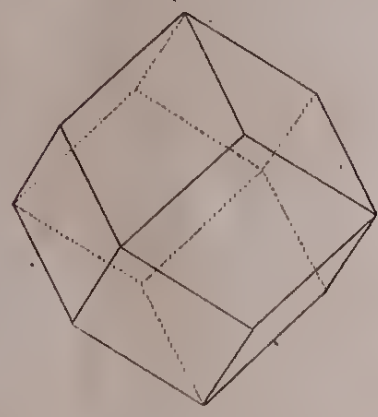

Fig. 109.

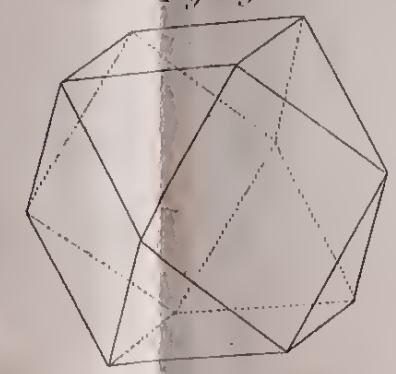

Fig. 115.

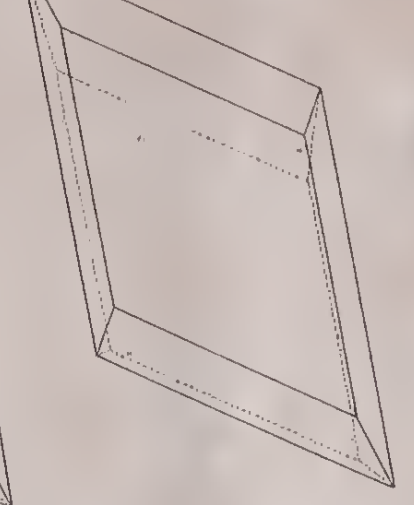

Fig. 116.

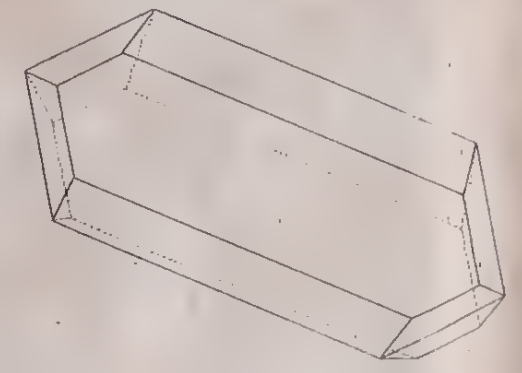

Fig. 112.

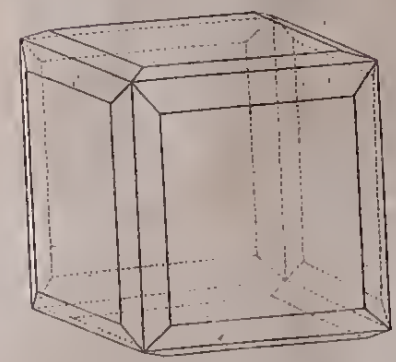

Fig. 113.

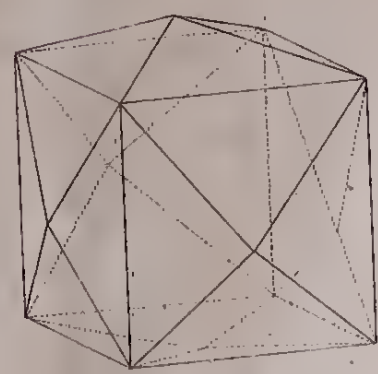
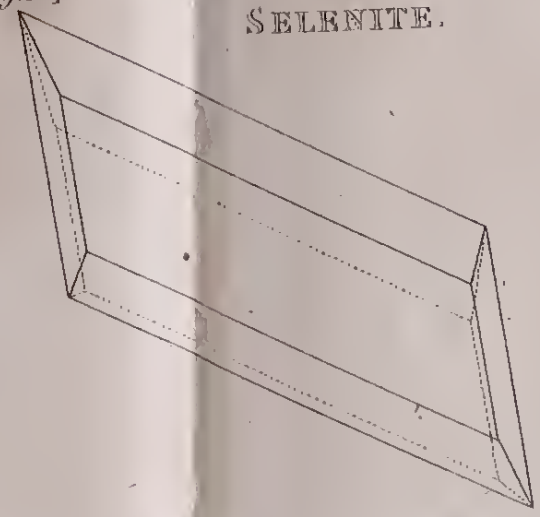
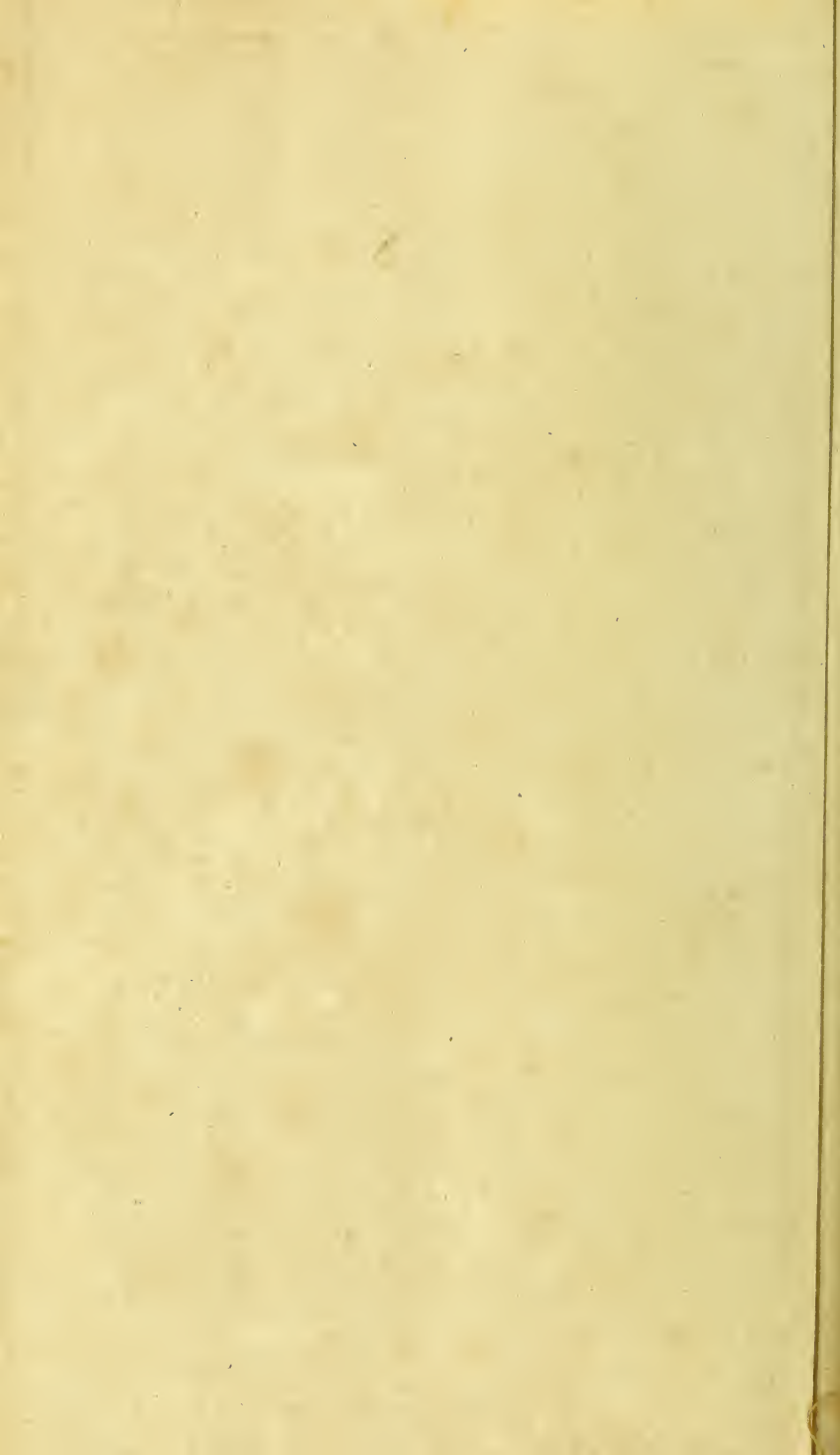

Fig. 114.



SELENITE.



STRAIGHT LAMELLAR HEAVY SPAR.

Fig. 117.

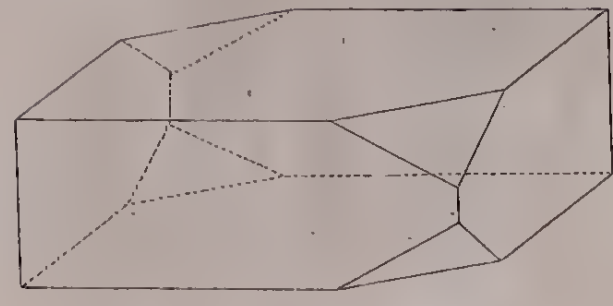

Fig. 118.

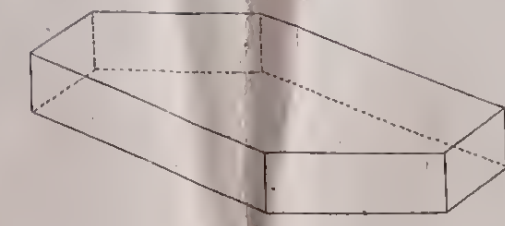
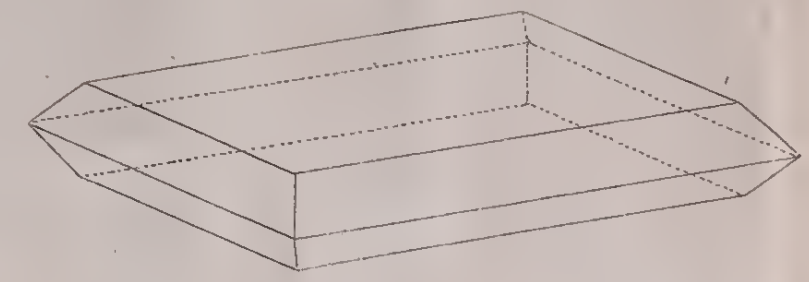

Fig. 119.



PRISMATIC HEAVY SPAR.

Fig. 120.

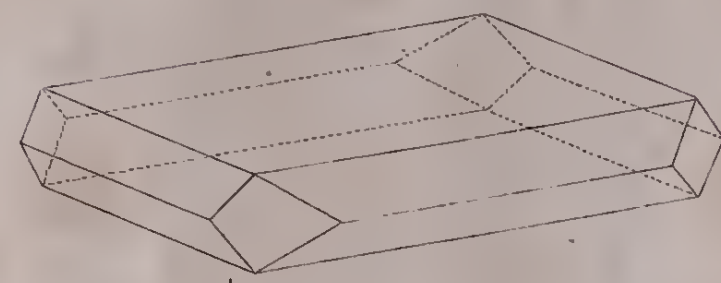
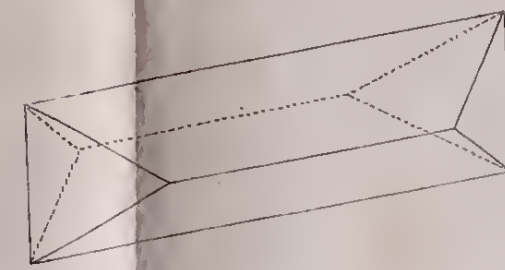

Fig. 121.



CELESTINE.

Fig. 122.

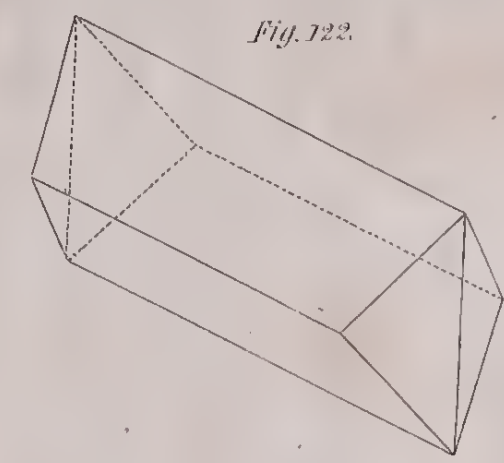

Fig. 123.

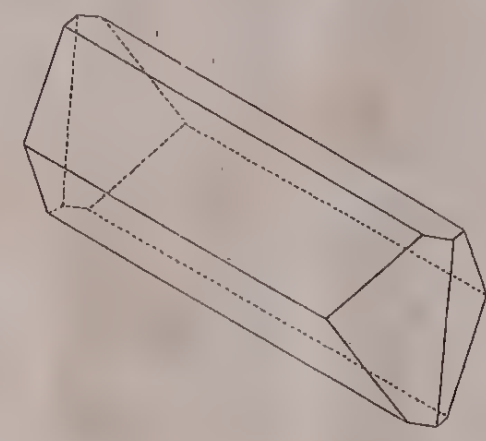

Fig. 124.

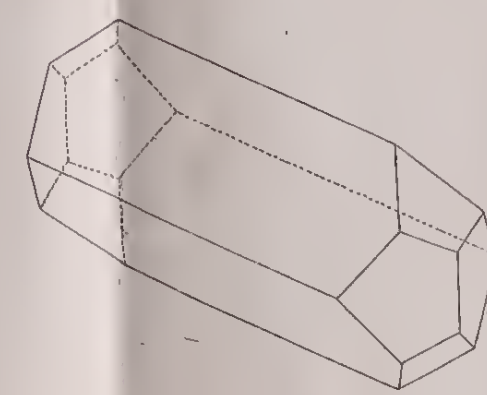
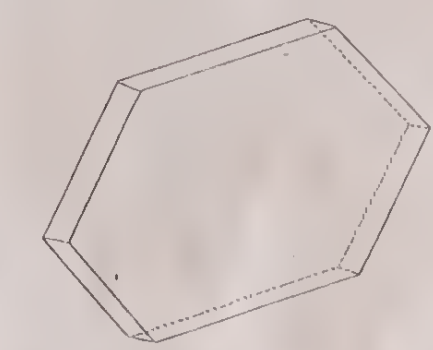
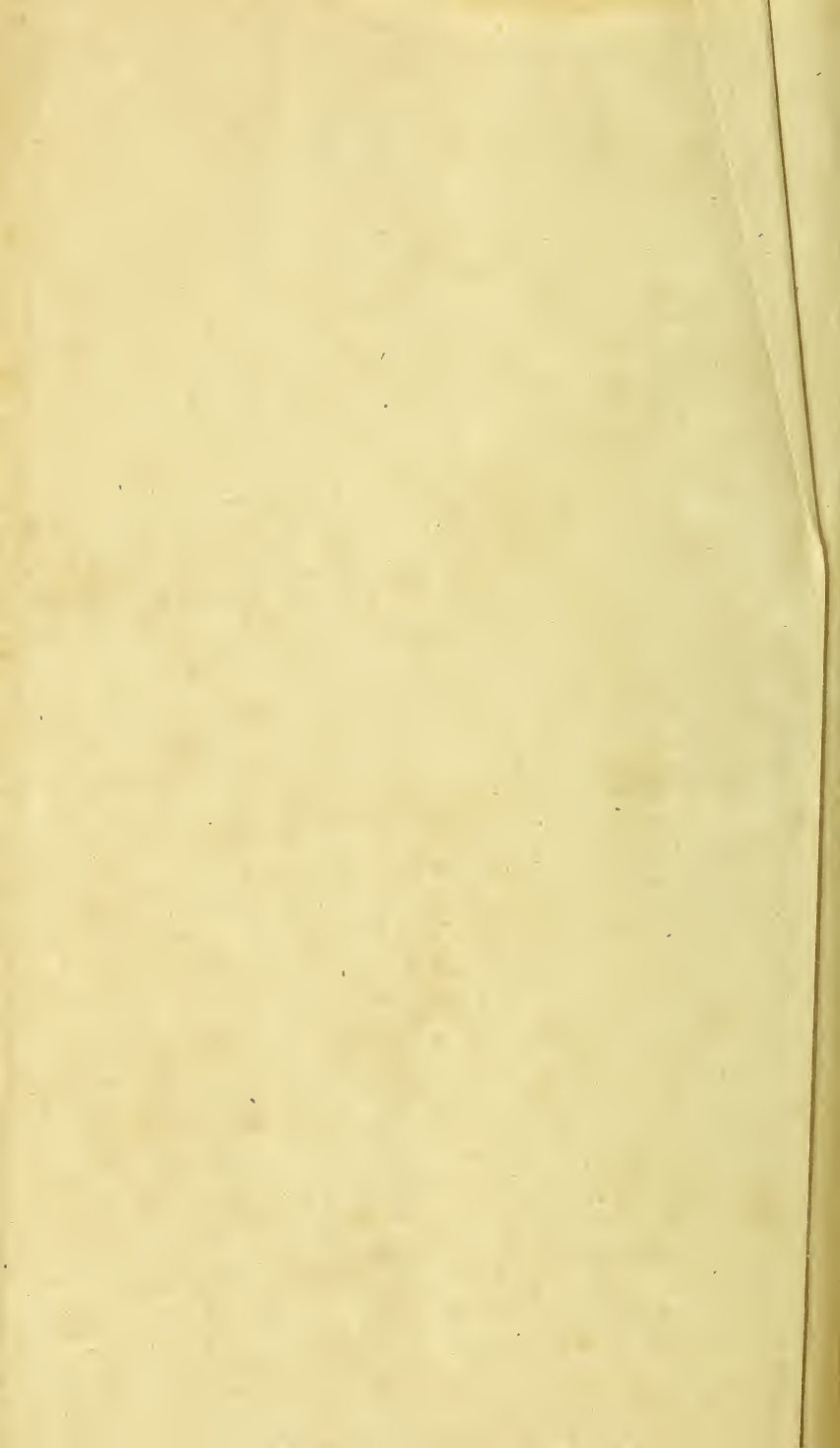
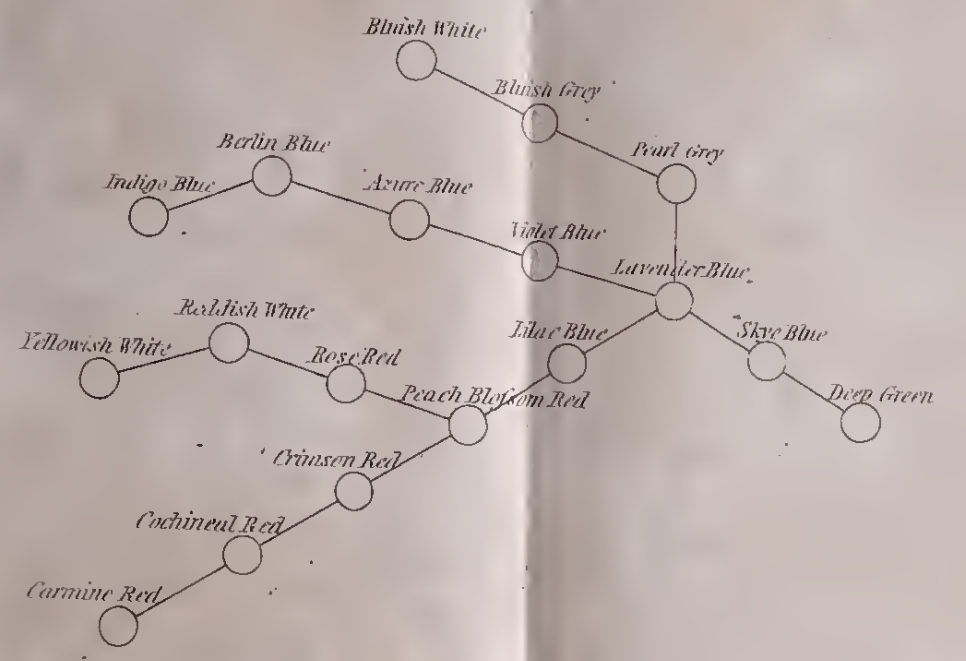

Fig. 125.





SAPPHIRE COLOUR SUITE.



DIAMOND COLOUR SUITE.

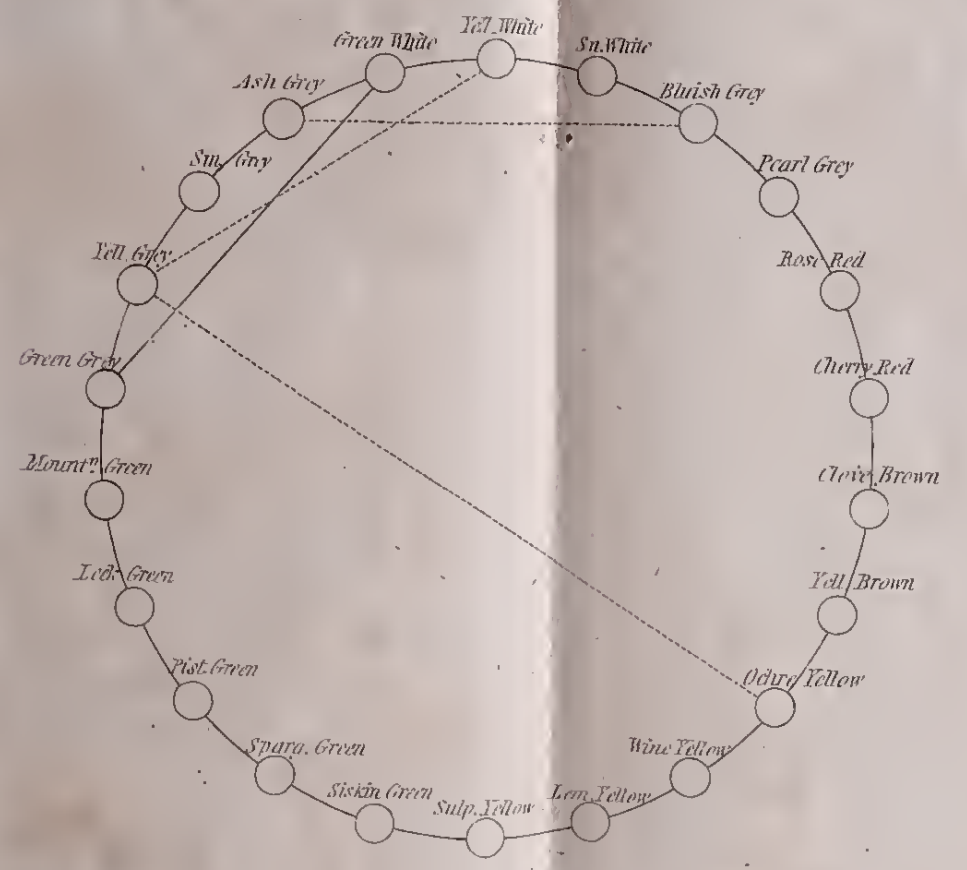



PLAN FOR ILLUSTRATING THE ALLIANCES OF SILVER WITH THE OTHER METALS.

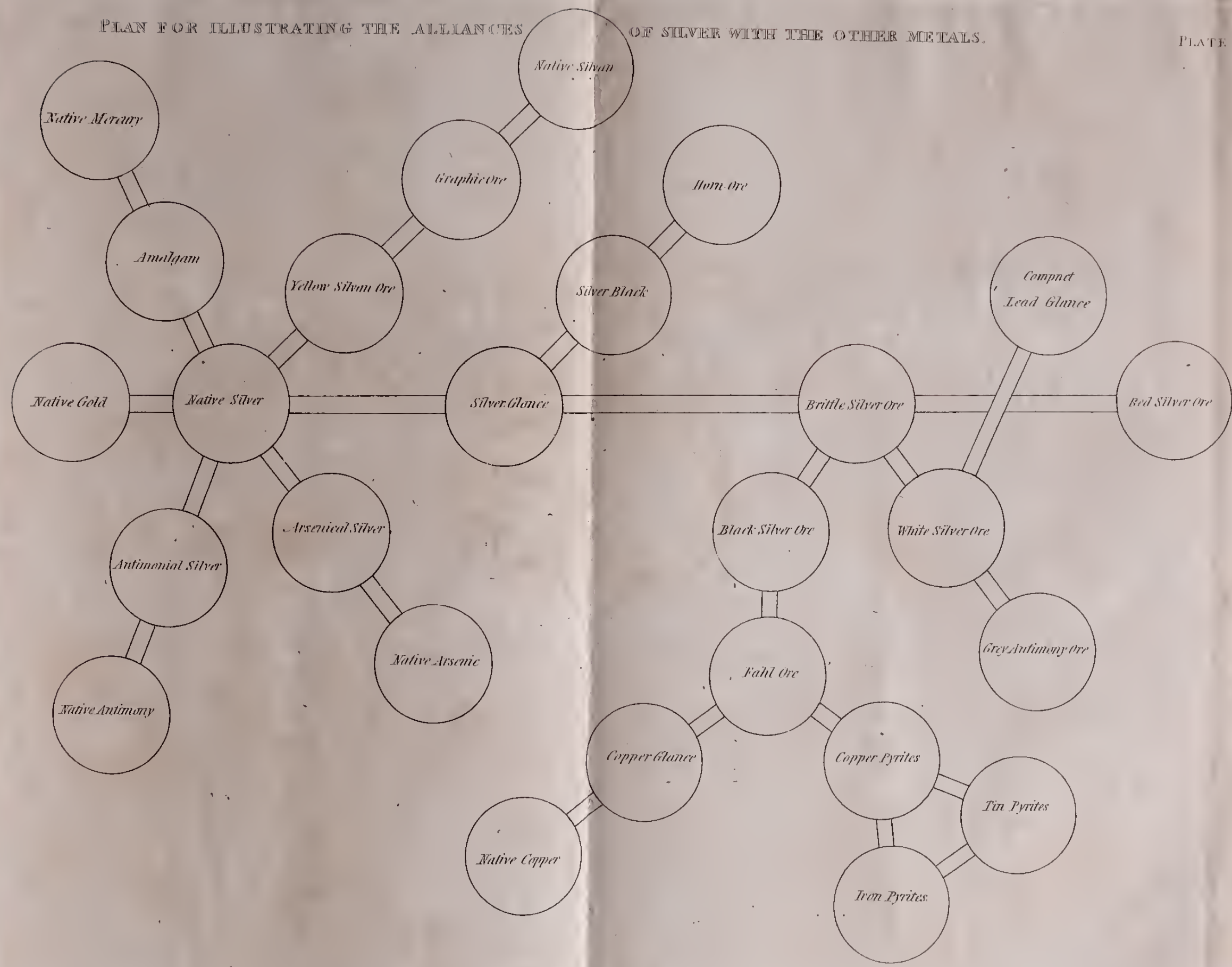



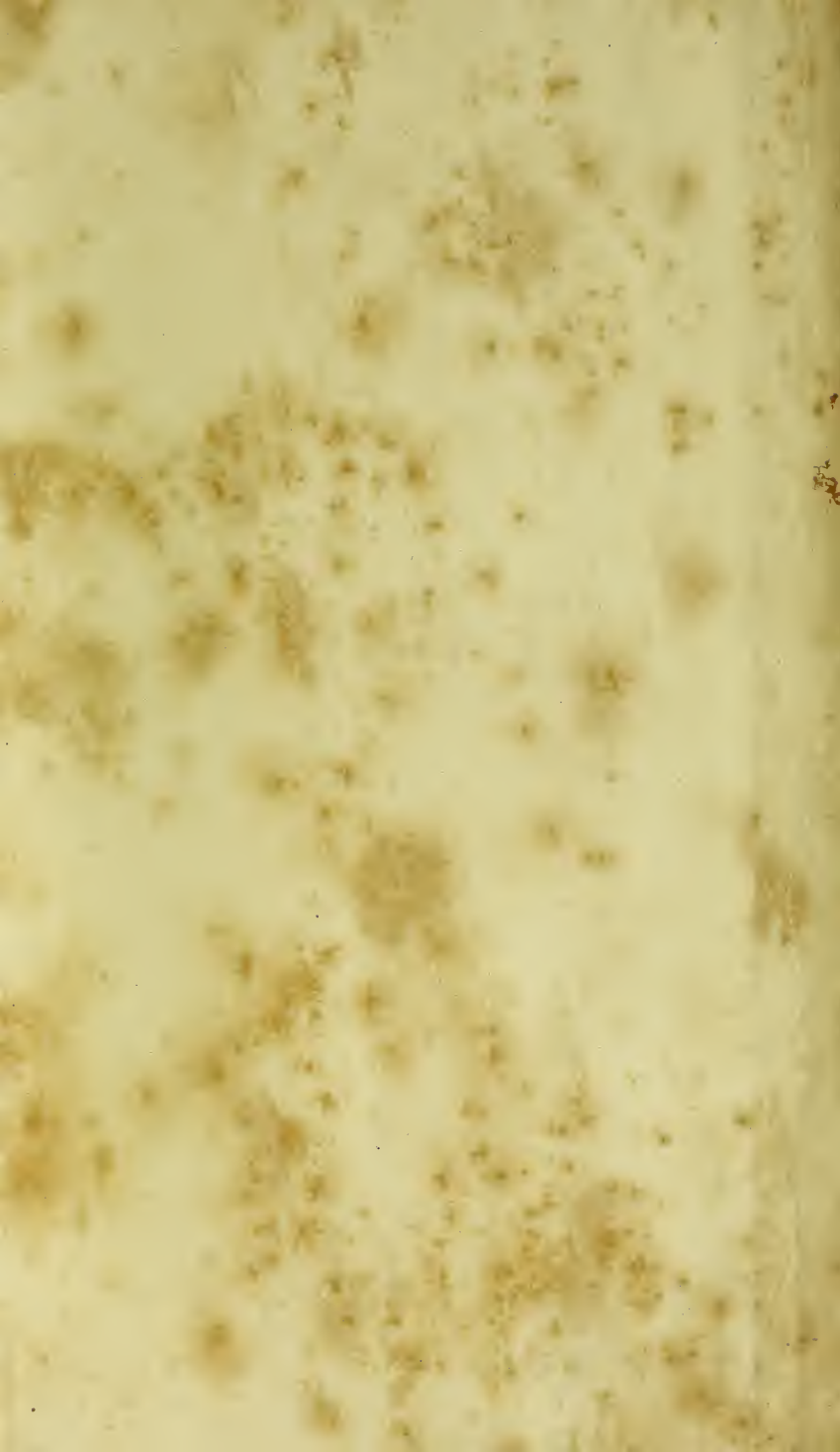



Q. 2 vols.

