



TJ 607  
F 78



Class TJ 607

Book F 78

Copyright N<sup>o</sup>                     

**COPYRIGHT DEPOSIT.**









# LOCOMOTIVE BREAKDOWNS

## Emergencies and Their Remedies

By GEO. L. FOWLER, M. E.

— BEING —

AN UP-TO-DATE CATECHISM TREATING ON ACCIDENTS AND  
BREAKDOWNS ON THE ROAD AND HOW TO REPAIR THEM.

EVERY KIND OF AN ACCIDENT WHICH IS LIKELY TO  
OCCUR TO A LOCOMOTIVE ENGINE WHILE IN SERV-  
ICE IS FULLY DISCUSSED AND ITS REMEDY GIVEN.

COMPOUND LOCOMOTIVES ARE INCLUDED

SO THAT RAILROAD MEN MAY POST THEM-

SELVES IN REGARD TO EMERGENCY

WORK IN CONNECTION WITH THIS

CLASS OF ENGINE.

Containing questions and their answers covering the sub-  
ject in a most complete manner, being intended as ex-  
amination questions for engineers and firemen, as  
well as all practical railroad men. A book  
that tells you what to do in any emergency.

NEW YORK

THE NORMAN W. HENLEY PUBLISHING CO.

132 NASSAU STREET

1903

TG 584  
F78

TJ 607  
F78

THE LIBRARY OF  
CONGRESS.  
Two Copies Received  
OCT 14 1903  
Copyright Entry  
Sep. 1 - 1903  
CLASS. a XX6. No  
67441  
COPY B.

---

COPYRIGHTED 1903

BY

THE NORMAN W. HENLEY PUBLISHING CO.

---

YIARBU INT  
222000 70

Composition, Printing and Electrotyping

By

MACGOWAN & SLIPPER

30 Beekman Street, New York, N. Y., U. S. A.



## PREFACE.

---

In presenting this collection of remedies for emergency locomotive work, it is impossible to make the claim of originality for all of them. All available sources of information on the subject have been freely used, and if credit has not been given for special devices to any particular publication, it is because, in many instances, it is difficult or impossible to properly do so, and because acknowledgment is hereby tendered to the whole range of railroad technical journalism in this country.

A criticism will probably be made by many on account of the small amount of space devoted to the Air Brake, whose diseases are such a prolific source of discussion. The reason for this apparent neglect lies in the fact that an authoritative "Air Brake Catechism," by Robert H. Blackall, has been published, which should be consulted.

An apology should perhaps be offered for the chapter on Engine Repairs, in which there are illustrated a number of handy devices used in the shops. These, of course, fail to come within the limits of road emergencies, but may be considered to be valuable where time is an important element, demanding an instant recourse to some means of effecting what practically amounts to emergency repairs.

Finally, in the chapter on the First Aid to the Injured a few simple directions have been given for the application of bandages and the treatment of injuries, as well as the movement of the patient by men who are not nurses or physicians, and who have no knowledge of the location of the bones, arteries, or other parts of the body, but who can nevertheless give such temporary aid that suffering will be alleviated and possibly life saved.

It is hoped the perusal and study of this book will enable the reader to cope with such accidents to his locomotive as may occur in service.

G. L. FOWLER, M.E.

October, 1903.



# TABLE OF CONTENTS.

---

CHAPTER.	PAGE
PREFACE.	
Introduction.	
I. Defective Valves .....	15
II. Accidents to the Valve Motion.....	34
III. Accidents to Cylinders, Steam Chests, and Pistons..	56
IV. Accidents to Guides, Crossheads, and Rods.....	67
V. Accidents to Running Gears.....	78
VI. Truck and Frame Accidents.....	93
VII. Boiler Troubles .....	108
VIII. Defective Throttle and Steam Connections.....	126
IX. Defective Draft Appliances.....	129
X. Pump and Injector Troubles.....	134
XI. Accidents to Cab Fixtures.....	145
XII. Tender Accidents .....	153
XIII. Miscellaneous Accidents .....	156
XIV. Compound Locomotive Accidents.....	174
XV. Tools and Appliances for Making Engine Repairs.....	203
XVI. Air Brake Troubles.....	217
XVII. Aid to the Injured.....	227



## LIST OF ILLUSTRATIONS.

---

	PAGE
Fig. 1. Valve Stem Clamp.....	18
Fig. 2. Method of Blocking Crosshead with Four-Bar Guides	20
Fig. 3. Method of Blocking a Laird Crosshead.....	21
Fig. 4. Method of Lashing Blocking for Alligator Cross- head .....	21
Fig. 5. Blocking Ports with Valve Removed.....	22
Fig. 6. Method of Blocking Valve with Broken Valve Stem..	22
Fig. 7. Holding Board Over Stuffing Box.....	23
Fig. 8. Repairs to a Broken Packing Box Gland.....	25
Fig. 9. Closing Stuffing Box when the Gland is Broken....	26
Fig. 10. The Tilting Action of the Yoke on the Valve.....	29
Fig. 11. Blocking Piston Valve in Central Position with Wood at Each End.....	31
Fig. 12. Method of Blocking Piston Valve with Steam Pres- sure .....	32
Fig. 13. Stuffing Box Packed with Hemp on Top of Broken Ring .....	34
Fig. 14. Rocker Arm Tied to Frame to Clear Link.....	37
Fig. 15. Link Blocked and Held by Wood Over Link Block..	38
Fig. 16. Link Blocked at Top and Bottom for Broken Lifting Shaft .....	40
Fig. 17. Blocking for Broken Lower End of Reverse Lever or Broken Reverse Lever Fulcrum.....	42
Fig. 18. Blocking for Broken Reverse Lever.....	42
Fig. 19. Lashing Lifting Arm to Beam Laid Across Frame..	43
Fig. 20. Clamping Two Eccentric Rods Together.....	45
Fig. 21. Location of Eccentrics Relatively to the Crank.....	46
Fig. 22. Side Elevation of Link Motion.....	50
Fig. 23. Application of Tram to Valve Stem.....	52
Fig. 24. Measuring Position of Link Block Relatively to Axle.	53
Fig. 25. Tramming Driving Wheel to Locate the Dead Center	54
Fig. 26. Hydrostatic Piston-Rod Remover.....	57
Fig. 27. Method of Blocking Port for Broken Cylinder Head.	58
Fig. 28. Method of Blocking Steam Passages with Broken Steam Chest .....	63

## LIST OF ILLUSTRATIONS.

	PAGE
Fig. 29. Clamping Board Over Port with Steam Chest.....	64
Fig. 30. Blocking of Piston with Board Inside of Cylinder....	68
Fig. 31. Method of Blocking for Broken Driving Axle.....	80
Fig. 32. Chaining Underhang Equalizer When Main Driving Axle is Broken.....	80
Fig. 33. Holding Up Rear End of Engine With Rails Chained to Frame and Tender for Broken Rear Driving Axle or Wheel.....	80
Fig. 34. Blocking up Axle with Broken Driving Wheels.....	82
Fig. 35. Blocking Beneath Spring Stirrup to Relieve Broken Driving Box Brass.....	85
Fig. 36. Striking Piece for Equalizer with a Cracked Spring Plate .....	90
Fig. 37. Method of Blocking Frame with Broken Main Driv- ing Spring or Hanger.....	90
Fig. 38. Blocking for Broken Driving Spring of Ten-Wheeled Engines .....	94
Fig. 39. Method of Chaining Four-Wheeled Truck Frame with a Broken Front Axle.....	95
Fig. 40. Method of Chaining Truck Equalizer on Mogul and Consolidation Locomotives with Broken Truck or Truck Axle .....	96
Fig. 41. Method of Chaining Truck Equalizer on Mogul or Consolidation Locomotives with Broken Truck or Truck Axle .....	99
Fig. 42. Outline of Method of Blocking Four-Wheeled Truck with Broken Frame .....	100
Fig. 43. Method of Chaining Four-Wheeled Truck with Broken Spring Hanger .....	101
Fig. 44. Method of Blocking Engine Truck Frame with Broken Spring .....	103
Fig. 45. Method of Blocking a Mogul or Consolidation Loco- motive with a Broken Equalizer .....	105
Fig. 46. Method of Blocking a Mogul or Consolidation Loco- motive with a Broken Cross Equalizer.....	105
Fig. 47. An Alternative Method of Blocking a Mogul or Con- solidation Locomotive with a Broken Cross Equalizer .....	106
Fig. 48. Pole Sharpened for Plugging Tube and Ready for Insertion .....	111

## LIST OF ILLUSTRATIONS.

	PAGE
Fig. 49. A Plugged Tube.....	111
Fig. 50. The Morgan Tube Stopper.....	112
Fig. 51. Lap Seam .....	116
Fig. 52. A Welt Seam.....	116
Fig. 53. A Bagged Crownsheet.....	121
Fig. 54. Plate Bolted Over Tee Head for Broken Steam Pipe.	128
Fig. 55. The Master Mechanic's Front End.....	131
Fig. 56. Boarding Used to Replace Broken Front Casting....	132
Fig. 57. Section of Locomotive Boiler Pump.....	143
Fig. 58. The Nathan Cylinder Lubricator.....	146
Fig. 59. The Gollmar Bell Ringer.....	150
Fig. 60. Spliced Tender Hose.....	153
Fig. 61. Chained up Tender Truck.....	154
Fig. 62. Common Wrecking Frog.....	160
Fig. 63. Wrecking Wedges for Re-Railing Wheels.....	160
Fig. 64. The Alexander Wrecking Frog.....	161
Fig. 65. The Cooke Wrecking Frog.....	162
Fig. 66. Section of Intercepting Valve of the Richmond Two-Cylinder Compound Locomotive.....	175
Fig. 67. Section of By-Pass Valve of Richmond Compound Locomotive in Open and Closed Position.....	180
Fig. 68. Plugged By-Pass Valve of Richmond Compound Locomotive .....	182
Fig. 69. Intercepting Valve of the Schenectady Compound Locomotive when Working as a Simple Engine....	186
Fig. 70. Intercepting Valve of the Schenectady Compound Locomotive in Position for Working as a Compound .....	188
Fig. 71. Longitudinal Section of Valve of Vauclain Compound Locomotive .....	199
Fig. 72. Bracket for Supporting Side or Main Rods.....	204
Fig. 73. Lever for Holding Side and Main Rods.....	204
Fig. 74. Tongs for Removing Oil Box Cellars.....	204
Fig. 75. Device for Lighting Headlights.....	205
Fig. 76. Hydraulic Bolt Starter.....	206
Fig. 77. Cannon Bolt Starter.....	207
Fig. 78. Air Ram for Removing Bolts.....	208
Fig. 79. Common Knots and Hitches.....	209
Fig. 80. Diagram of Frame Weld.....	213
Fig. 81. Method of Strengthening a Cracked Bridge.....	214

## LIST OF ILLUSTRATIONS.

	PAGE
Fig. 82. Banded Crank .....	215
Fig. 83. Strengthening Crank, with Dove-tailed Insert.....	215
Fig. 84. Eight-Inch Westinghouse Air Pump.....	218
Fig. 85. Nine-and-one-half Inch Westinghouse Air Pump....	221
Fig. 86. Application of Triangular Bandage to the Head.....	231
Fig. 87. Temple and Jaw Tied with Triangular Bandage....	231
Fig. 88. Triangular Bandages Used as a Sling and about a Wounded Arm .....	232
Fig. 89. Triangular Bandage Tied About the Hand.....	233
Fig. 90. Wounded Hand Bandaged with a Strip Bandage....	233
Fig. 91. Tourniquet Applied to Limb.....	233
Fig. 92. The Fireman's Lift, First Position.....	235
Fig. 93. The Fireman's Lift, Second Position.....	235
Fig. 94. The Fireman's Lift, Third Position.....	236
Fig. 95. The Fireman's Lift, Fourth Position.....	236
Fig. 96. The Fireman's Lift, Fifth and Final Position with the Patient on the Shoulders.....	236



# LOCOMOTIVE BREAKDOWNS, EMERGENCIES, AND THEIR REMEDIES.

---

## INTRODUCTION.

*Q. What are the first duties of the engineer in case of the breakdown upon the road?*

A. The first thing to be done after stopping, is to see to it that the train is protected by flagmen in both directions in case of a single track road, and in the rear on a double track. If the nature of the accident is such that both tracks of a double track road are in any way obstructed, flagmen should be sent to the front as well as the rear. Should the breakdown be one that is likely to require much time to put the engine in running order, word should be sent to the nearest telegraph station, flagging a passing train to send the message if necessary.

The next thing to do is to determine the character of the mishap and locate the damage; ascertaining whether it will be necessary to ask for outside assistance, and, if it will be, sending to the nearest telegraph station for the same at once. Finally, work should be started immediately to put the engine in condition to move. There is almost always something that can be done before outside help arrives that will facilitate the preparations and shorten the time during which the disabled engine will be blocking the tracks.

*Q. Name a few of the principal troubles that are to be looked for on a locomotive.*

A. The troubles experienced in every day service on locomotives are those ordinarily due to wear and tear and to bad water and coal. These may cause the valves and pistons to leak and blow; the moving parts of the machinery to pound while in motion; the draft to become insufficient to maintain the fire at the proper intensity to generate a sufficient quantity of steam; the injectors to fail to work, and the boiler to prime or foam.

*Q. Are any of the troubles named above dangerous to the operation of the locomotive?*

A. That will depend upon the degree to which the defect has been allowed to advance. In the case of a blowing valve or piston there is usually little danger in running, provided that it is due to simple wear and not to a broken part. Where the pounding is light there may be no immediate danger; but this defect will continually increase and, when it is allowed to become excessive, a breakdown may be the result. Where the water is of such a character as to cause the boiler to foam or prime there is danger that water may be carried over to the cylinders and cause a breakage there. A poor draft may merely mean a delayed train. It should always be remembered, however, that any defect, no matter how slight, may be the direct cause of greater ones, which may result in a breakdown or disaster.

*Q. What are the duties of the engineer in regard to these classes of defects?*

A. He should observe them closely and, in case they

appear to indicate a dangerous condition of affairs, he should stop at once and apply the proper remedy. Should there be no apparent danger of an immediate breakdown he should proceed to the terminal and report the defect to the roundhouse foreman for repairs.

*Q. What preparation should be made in order to be able to deal with emergencies and accidents rapidly and without hesitation?*

A. In the first place the engineer should familiarize himself with all of the details of locomotive construction and especially of that class which he is called upon to run. It will be found that each will possess some peculiarity of construction that will make it necessary to modify the instructions given in the following pages to a greater or less extent. This will be especially true of those calling for blocking and chaining where the parts are closely crowded together. It will be well, then, as a preparation for what may happen, to go over the particular engine in detail and see what can and must be done in the case of a breakdown of any individual part. This will be a particularly valuable preparation in the matter of fastening and chaining in connection with the springs, driving boxes and related parts. In short, it should be borne in mind that it is the man who has worked out the problem in advance that is the one who is ready to deal with an emergency.



## CHAPTER I.

### Valve Defects.

*Q. How is a blow in a valve detected?*

A. The principal difference between the blowing of a valve and a piston in the cylinder is that that of the valve is apt to be the more steady of the two. There is also a difference in the sound which it is impossible to describe and which can only be learned by actual experience on an engine. The only suggestion that can be made is that a valve blow is apt to have a suggestion of a whistle in it, while that of the piston partakes more of the nature of a roar. This sound can be heard more distinctly if the furnace door is open than if it is closed.

*Q. Is an intermittent blow a sure indication that it is not caused by a valve?*

A. No. A valve sometimes leaks intermittently, producing a corresponding blow. That is to say, it may not leak at all points of its travel, or it may become tilted at some one point, thus allowing the steam to blow through. This latter usually occurs at the end of the travel, but rarely or never happens at all with the balanced valves.

*Q. Is a whistling in the exhaust a certain indication of a leaky valve?*

A. No. If the exhaust nozzles or passages become clogged or gummed with oil from the cylinder, they frequently produce a whistling in the exhaust that closely resembles the sound caused by a leaky valve.

*Q. Having determined that it is a valve that is causing the blow, how can it be located?*

A. As the valve blow is apt to be continuous no indication of its location can be obtained by watching the effect of crank positions on the sound. The test can best be applied when the engine is at rest. Adjust the valve motion so that the rocker arm is vertical and the valve is in its mid position and then, by admitting a little steam, the blow can be heard quite distinctly. A method of determination while the engine is in motion, is to go out upon the running board while it is moving slowly and yet working hard and place the foot upon the valve rod. The side upon which the blow takes place is apt to tremble and show signs of an extra stress. This, however, may also be due to the hard running of the valve on account of insufficient lubrication. Still another means is to place the engine on the quarters successively, open the throttle a very little and move the reverse lever to and fro. The leak will be upon that side having the crank pins on the quarter when the reverse lever moves with the greater difficulty.

Finally the same principle may be applied while the engine is in motion, by unlatching the reverse levers and holding it by hand when moving slowly and noticing the location of the cranks when a distinct jerk takes place. The blow will usually be found to be on the side whose cranks were on the quarters when this occurs.

*Q. What is apt to be the first indication of a leaky valve?*

A. If the leak is due to a broken strip, the blow may announce itself suddenly and with full force. If it is due to

wear of the valve face or seat it is apt to come on gradually, increasing from day to day with the abrasion of the two parts in contact.

*Q. What is the characteristic feature of a blow resulting from a leaking piston?*

A. It is apt to come on suddenly and is intermittent.

*Q. How can a piston blow be located?*

A. Place the engine with the cranks on the quarter successively and with the reverse lever in the forward notch start the throttle slightly; taking care to have the cylinder cocks open. If steam appears at both cocks of the piston whose crank is on the quarter, the leak is on that side. Where the steam appears at one cock only the piston is tight.

*Q. If, in making this test, steam does appear at both cylinder cocks is it a positive evidence of a leaky piston?*

A. No. It may be due to a broken bridge between the ports of the cylinder casting, which would allow steam to pass through from the steam chest or ports to both ends of the cylinder at once.

*Q. How can it be ascertained whether the blow is due to this cause or not?*

A. By testing the matter with the reverse lever in both forward and back positions. If steam appears at but one cylinder cock with the lever in one position and at both cocks when in the other it is a sign that a broken bridge will be found to be the cause of a blow.

*Q. In case a violent and steady blow is suddenly developed to what can it probably be attributed?*

A. To a breakage of a valve, or a portion of the cylinder

casting within the steam chest, or to some of the valve connections, such as yoke, stem or packing strips.

*Q. What should be done under these circumstances?*

A. Stop at once and ascertain the exact cause, by removing the steam chest cover.

*Q. In case it is found that a bridge has been broken what should be done?*

A. If the valve has not been injured, the broken pieces

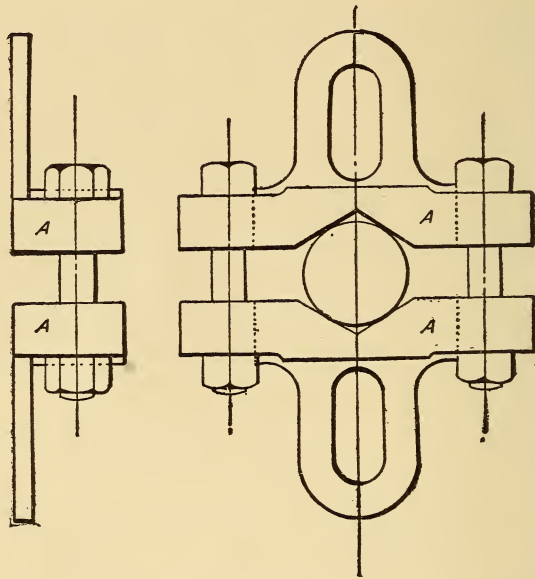

FIG. 1.—VALVE STEM CLAMP.

of the bridge should be removed and the valve clamped in the central position with a valve stem clamp similar to that shown in Fig. 1. It consists of the two parts *AA*, with V notches for setting down over the valve stem and bolts for tightening it so that it will hold. Each is also provided with



an extension and slotted hole for setting over the gland studs, the nuts of which will hold it in the proper position. The method of application is to first adjust the valve, then slip the clamps into position and up against the face of the gland. Then tighten the clamping bolts, after which the gland nuts can be run home, thus firmly fixing the valve in the position in which it is placed.

Before fixing the valve the valve rod should be disconnected from the rocker arm and separated from the valve stem. As this disables the engine on one side the other working parts should be disconnected also.

*Q. How is an engine to be disconnected in case of a disabled valve?*

A. The valve rod should be disconnected from the rocker arm as already stated in the answer to the previous question. If the valve rod cannot be readily removed, it should be sprung slightly to one side to prevent the rocker arm from striking it. It will not be necessary to disconnect the link or eccentric rods.

The connecting rod should be taken down, and the crosshead pushed to the extreme limit of its stroke and then blocked in position. As a general statement, it may be said that it makes no difference at which end of the stroke the crosshead is blocked, but on some consolidation, mogul and ten-wheeled engines the crankpin of the forward driving wheel will not clear the crosshead with the latter blocked at the back end of its stroke. It is well, therefore, to always block the crosshead and piston at the extreme front end of the stroke.

*Q. How is the crosshead to be blocked when disconnecting?*

A. In case of a crosshead working in four-bar guides, the blocking is done as shown in Fig. 2. The crosshead is pushed with the piston to the extreme forward end of the stroke and a block of wood, *A*, is inserted between the guides completely filling the space between the back end of the crosshead and the guide block. The block is itself held in

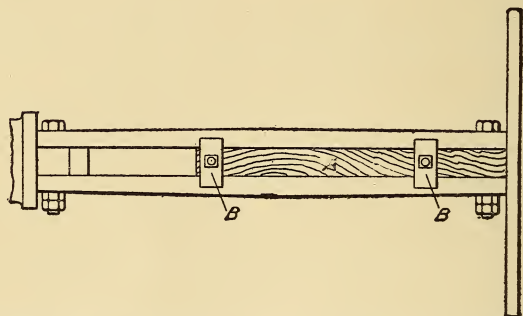

FIG. 2.—METHOD OF BLOCKING CROSSHEAD WITH FOUR-BAR GUIDES.

place by lashing or wrought iron straps *B* bolted to either side of the block *A* by a single through bolt.

For crossheads of the Laird type, the block may be fitted against the bottom of the guide and held in position by lashing or by straps and bolts as shown in Fig. 3.

For crossheads of the alligator type working between two guides, the same method of fastening can be used as in Fig. 3. Should the straps and bolts not be available for holding the block, it can be lashed in place as shown in Fig. 4.

*Q. What should be done in case a valve is broken?*

A. In case the valve is still in such a condition that it

can be used to cover both the steam ports, set it in the central position and clamp it there by means of the valve stem clamp (see Fig. 1) and then disconnect one side (see page

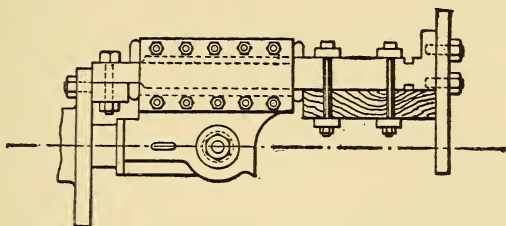

FIG. 3.—METHOD OF BLOCKING A LAIRD CROSSHEAD.

19) and block the crosshead (see Figs. 2, 3, and 4). The engine can then be run with the other side.

In case the valve is so badly damaged that it cannot be used, as indicated, the ports may be blocked by fitting strips into them or a board may be laid over the whole valve seat as in Fig. 5 and be held down by blocking against which

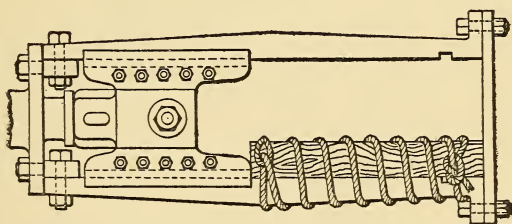

FIG. 4.—METHOD OF LASHING BLOCKING FOR ALLIGATOR CROSSHEAD.

the steam chest cover is made to bear, thus holding the whole in position. It is particularly important that this board have a bearing all round the inlet passage or port at *A*

so as to prevent the admission of steam to the steam chest. The valve is, of course, to be removed and the engine disconnected as before.

*Q. What should be done in case of a broken valve stem or yoke?*

*A.* The engine must be disconnected and the crosshead blocked (see pages 19 and 20).

If the valve stem is broken outside the steam chest the

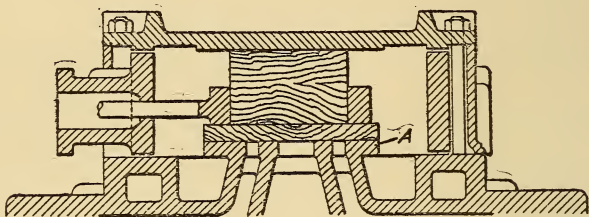

FIG. 5.—BLOCKING PORTS WITH VALVE REMOVED.

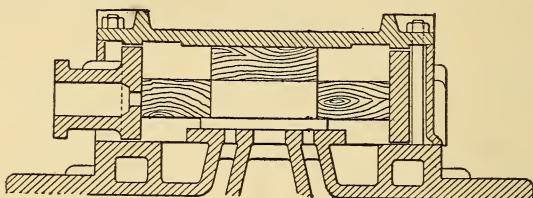

FIG. 6.—METHOD OF BLOCKING VALVE WITH BROKEN VALVE STEM.

valve should be put in the central position and clamped by means of the valve stem clamp (see page 18).

If the stem is broken inside the steam chest, it will be necessary to block the valve. This is done by fitting blocks of wood as shown in Fig. 6 in at the front and back of the

valve, between it and the steam chest, thus holding it in the central position. If it is an unbalanced valve it can be held down by blocking bearing against the steam chest cover. A balanced valve will need no such blocking.

In case of a valve stem or yoke thus broken within the steam chest, the removal of the same will leave an opening through the stuffing box. This must be closed and it can be done by means of a thin piece of board held against the out-

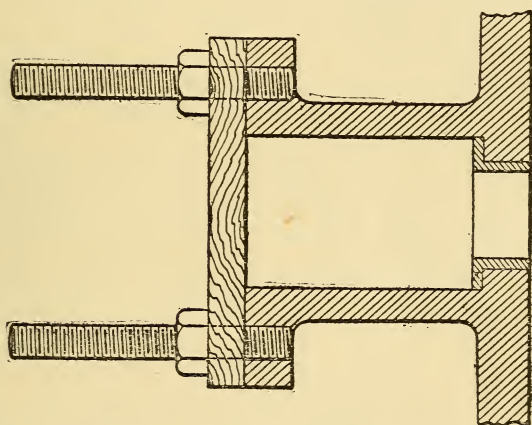

FIG. 7.—HOLDING BOARD OVER STUFFING BOX.

side of the opening with the gland studs and nuts, as shown in Fig. 7.

*Q. How can a broken valve stem or yoke be detected and located?*

*A.* The engine should be placed upon the quarter and the cylinder cocks opened. Then admit a little steam to the steam chest and move the reverse lever backwards and forwards. If steam does not escape alternately from the two

cocks the stem or yoke will probably be found to be broken. In case one side is all right, put the other crank on the quarter and repeat the test.

*Q. How can a broken packing strip of a valve be detected?*

A. When a packing blows, a great deal if not all of the balance will be lost. This causes the valve to work hard. The best method of locating or detecting it is to lay out on the running board and grasp the valve stem in the hand. It will be found that the one with the broken packing strips will be working with very much greater resistance than the one in proper condition, and can be readily detected by the feeling. This work cannot very well be done when the engine is at rest, although it is possible to do it by setting the engine on the quarters successively, admitting a little steam to the steam chest and having an assistant move the reverse lever to and fro while the inspector holds a hand on the valve stem.

The trouble that may be experienced with this method is that the loss of balance for the valve may cause it to move with such difficulty that the reverse lever cannot be operated. (See also page 26.)

*Q. If a valve stem or piston rod gland is broken what should be done?*

A. If the gland breaks in two so that it is parted through the body, it is usually possible to repair it by wrapping the part outside the stuffing box with wire and then using a piece of board to push it into position with a steady pressure as shown in Fig. 8. In case a lug only is broken off, the

piece of board put into position, as illustrated, will serve to bring the gland home. It must, of course, be cut open on one side as shown at *A*, in order to set over the stem or piston rod without necessitating the removal of the same from its position.

Another method that may be used, especially upon the left side where the escaping steam will not be a serious inconvenience to the engineer, is to remove a portion of the packing so as to allow the gland to enter its full length into

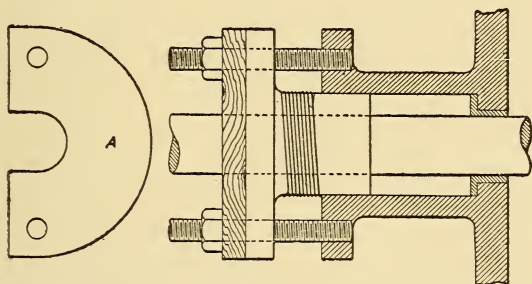

FIG. 8.—REPAIRS TO A BROKEN PACKING BOX GLAND.

the stuffing box, and to hold it there by screwing down tight with one stud. This, of course, can only be done when at least one lug and stud are left in good condition and the body of the gland is uninjured.

In case both studs are broken and the gland fractured beyond the possibility of repairing, the stuffing box can still be kept tight. Cut a piece of board like that shown at *A* in Fig. 8, and after packing the stuffing box full of waste or packing, hold this board over the opening by means of a brace or braces as shown in Fig. 9. These may be two

pieces of plank or one with the notch cut out to span the piston rod, and guides if necessary, and held in place by a piece of bell-cord running to a brace laid across the front cylinder head or front end of the steam chest, and tightened with a tourniquet, or a twist in the doubled cord. This last method is rather clumsy in appearance but can be made to

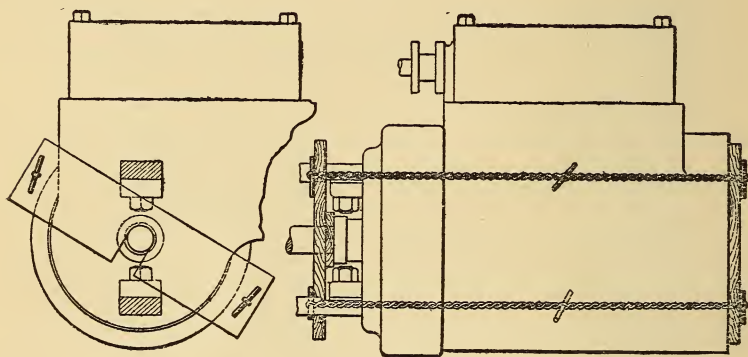

FIG. 9.—CLOSING STUFFING BOX WHEN THE GLAND IS  
BROKEN.

answer, besides being readily applied, since it should not take more than fifteen minutes to do the work.

*Q. What is a dry valve and how can it be located?*

*A.* A dry valve is one that has not received the proper amount of lubrication.

It can be located in exactly the same manner as a broken packing strip. In addition to this it will be found that, when the engine is in motion, there will be a decided jerk to the reverse lever when the crank, upon the side where the dryness exists, passes the top or bottom quarter. By



noting the point at which this jerk takes place the side can be located.

*Q. What is a cocked valve and how is it remedied?*

A. A cocked valve is caused by the valve lifting from its seat and becoming so cramped in the yoke that it cannot return to its proper position. It is usually caused by the yoke being made too tight. It generally takes place after steam has been shut off and at the time of making a stop.

When starting again the trouble manifests itself by a roaring and blow such as would be occasioned by a broken bridge, and may easily be mistaken for such a defect. The remedy to be applied is to jerk the reverse lever. This produces a jar at the yoke which will usually loosen the valve and allow it to drop back into position.

*Q. How can the general location of valve motion defects be determined?*

A. By opening the cylinder cocks and watching the escape of steam while the engine is in motion. It should be noted that, when the engine is running forward, steam should escape from the forward cylinder cock during the backward stroke of the piston and out of the back cylinder cock during the forward stroke of the piston. Any variation from this indicates that there is something wrong and also the side where the trouble will be found.

*Q. When the valves and the valve motion are in good condition what should be the character of the exhaust?*

A. It should take place at uniform intervals of time and each blast should be of equal intensity.

*Q. What does a variation from this condition indicate*

*and does it necessarily indicate a serious condition of affairs?*

A. It indicates that there is some defect either in the valve motion or the related parts, but does not necessarily mean that the engine needs immediate attention or that there is any serious loss in the efficiency of its operation.

*Q. What are some of the causes that may produce this inequality in the intensity or the timing of the exhaust?*

A. They may be almost any defect related to the valve motion. The most common cause is one that is irremediable except by a reconstruction of the valve motion and is due to inherent defects of design. The link motion forms a very delicate combination that must be adjusted with the utmost accuracy or the defect will manifest itself in the "squareness" of the exhaust. Other accidental phenomena are bent main driving axles, slipped eccentrics, loose eccentric straps, bent eccentric rods, bent or loose rockers, bent valve stems, loose valves, inequality in the size of steam passages, unequal travel of the valve, clogged exhaust nozzles, holes worn in the petticoat pipe and exhaust nozzles not in proper alignment with the stack.

*Q. How can the general condition of the valves be tested?*

A. The engine may be placed on the quarters and the wheels blocked. The reverse lever is then so adjusted that the rocker arm stands vertically. The cylinder cocks are open and a little steam is admitted to the steam chest. In this position no steam should escape from the cylinder cocks. If any does escape it indicates that there is a leak.

It sometimes happens that a valve will be tight in its cen-

tral position and leak at the end of the stroke. In making the above examination it is well to move the reverse lever so as to change the position of the valve, but still not enough to uncover the ports.

*Q. How does wear ordinarily take place on valves and seats?*

A. The average tendency is for the valve to wear convex and the seat concave. This may be due to a variety and

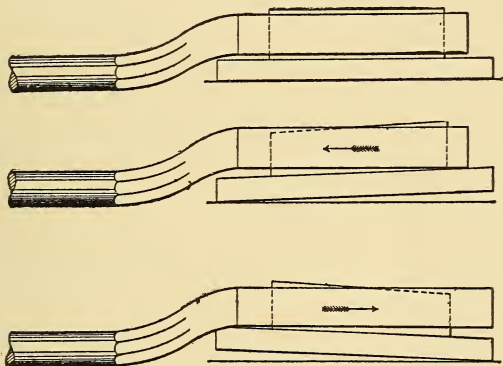

FIG. 10.—THE TILTING ACTION OF THE YOKE ON THE VALVE.

combination of causes. The lip of the valve projects beyond the line of the yoke and the looseness of the latter has a tendency to tilt the valve as shown in Fig. 10. This throws an extra pressure upon the edges of the valve tending to wear it convex. The tendency to wear the seats concave is probably due, to a great extent, to the practice of working the engine upon the road with a reduced throw, thus giving more wear to the center of the seat than to the

ends. This causes a slight concave wear and, when the valve is again thrown into full gear and its maximum travel, the ends travel up on the unworn portions of the valve seat, with an increased pressure per square inch of surface, and are worn away leaving a convex contour.

*Q. When the valves and seats become so worn that they are leaky what should be done?*

A. The valves should be removed and planed to a smooth flat surface, and the valve seats be refaced. This latter can be done with a portable rotary planer which may be clamped into position on top of the cylinder when the steam chest has been removed. When, by repeatedly facing it, the valve seat has been worn away entirely a false one may be put in, and thus avoid the necessity of sacrificing the cylinder casting.

*Q. What is the cause of piston valves sticking and jerking the reverse lever?*

A. It may be due to the valves running dry as with the flat valve, or to an inequality of expansion between the valve and its case. If the valve is turned to a snug fit and is made light the admission of live steam to its surfaces will cause it to heat and expand more rapidly than will the heavier casting forming the steam chest. When this occurs the valve will be apt to catch and bind, a condition that may prevail when the engine is started quickly after a long period of rest.

*Q. In case a piston valve becomes disabled, how should it be tested?*

A. The piston valve may be handled, in every way, in the

same manner as the flat valve. If it is to be blocked in the central position, the work may be done by clamping the valve stem as described in the answer on page 18. If it is to be blocked with wood on the inside, a piece fitted in at each end and bearing against the heads of the steam chest, as shown in Fig. 11, will hold the valve in any desired position.

When this kind of blocking is to be done the best way is to remove both steam chest heads, set the valve in the central position, and fit in blocks that will just bear against the heads and the valve.

If, however, it is definitely known whether the valve has

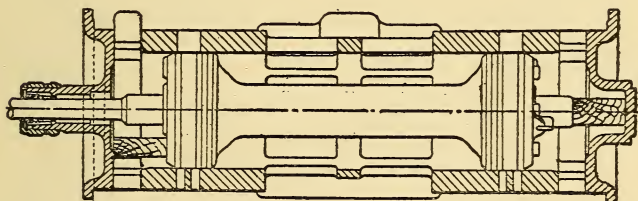

FIG. 11.—BLOCKING PISTON VALVE IN CENTRAL POSITION WITH WOOD AT EACH END.

inside or outside admission a shorter plan may be followed. Push the valves against the front head and clamp it in that position. This will permit the cylinder to be filled with steam, which will hold the piston against one head. Disconnect the main rod and push the piston to that end of the cylinder where the steam will tend to hold it and block it there (see page 20). This is shown in Fig. 12, where the mottled surface indicates the live steam.

This method must not be followed, however, unless a per-

fect certainty exists as to the construction and action of the valve.

*Q. Is there any tendency on the part of piston or flat slide valves to move in the steam chest that makes it necessary to block them when the engine is disabled?*

A. No. The steam pressure upon a flat valve merely tends to hold it firmly to its seat, while the piston valve is supposedly perfectly balanced and has no tendency to move. It is unsafe, however, to trust to this as the jarring due to the motion of the engine when running, may serve to move

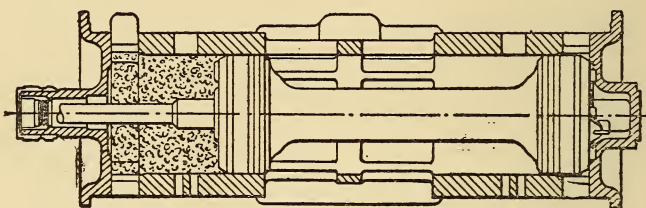

FIG. 12.—METHOD OF BLOCKING PISTON VALVE WITH STEAM PRESSURE.

the valve, or the diameters of the piston valve may be such as to cause an inequality of pressure and a tendency to move. Under no circumstances, then, should an engine with a disabled valve be moved by its own steam without first blocking the same.

*Q. If, when an engine is disconnected and the valve blocked in position, it is found that steam leaks into the cylinder through the blocked valve, what should be done?*

A. The cylinder cock at the end of the cylinder at which the piston is blocked should be removed. This permits the

steam to escape and does away with any tendency to move it away from that position. It will be better to leave the other cylinder cock in place, as steam in that end of the cylinder will assist in holding the piston in its blocked position.

*Q. What will be the effect and what should be done if the lip at one edge of the main valve is broken?*

A. The effect will be the same as though the outside lap of the valve had been removed on that side. This causes a later cut-off for any given travel of the valve, besides giving a wider port opening. The result on a locomotive will be that, with the link in full-gear, the broken edge of the valve may travel so far as to uncover the exhaust port and thus permit the live steam of the chest to blow into the former and out at the stack, while it may or may not cover the port at the end of its stroke. The course to be followed will depend upon the extent of the break. The blowing of steam out at the exhaust may be prevented by shortening the travel by hooking up the link, so that it may be possible to continue running with no other change. Should the port not be closed the cylinder cocks must be kept open. Of course the steam chest cover must be taken off to ascertain the amount of damage, and remove the broken part lest it catch in the valve or ports and wreck the cylinder.

## CHAPTER II.

### Accidents to the Valve Motion.

*Q. If the rings of metallic piston-rod or valve-stem packing are broken, how can the trouble be remedied?*

A. The gland should be removed and the broken rings taken out of the stuffing box. If any are in good condition, as some will usually be, they should be left in position. If all are broken select the least damaged one and put it in at

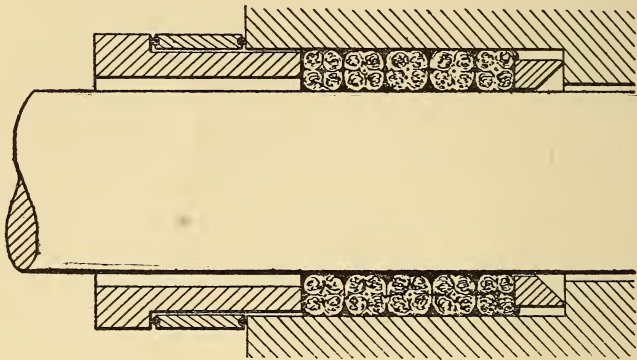

FIG. 13.—STUFFING BOX PACKED WITH HEMP ON TOP OF  
BROKEN RING.

the bottom. The space previously occupied by the rings removed should then be filled with a fibrous packing, as in Fig. 13. For this purpose it is possible to use hemp or other packing, wicking, strips of cloth, or waste. The box packed in this way should be covered with the gland and may be run for a long time in that condition if the work is



well done. The principal precautions to be taken are that the packing is not put in too tightly but in such a way that it will preserve a certain amount of elasticity, and should be thoroughly saturated with oil.

*Q. What should be done in case a rocker arm is broken?*

A. If it is the upper arm that is broken the piece should be disconnected from the valve stem and the valve clamped in the central position as described in the answer on page 18. The main rod should then be taken down and the crosshead blocked (see page 20). There will be no necessity of taking down any more of the valve motion, and the engine can be run under steam with the other side.

If it is the lower arm that is broken proceed in the same way and disconnect the fractured piece from the link block, unless it is evident that it can hang down and swing clear of all other parts when the engine is in motion. The better way, however, is to remove it.

*Q. When an upper rocker arm is broken how can the valve be brought to and set in its central position?*

A. Ordinarily this is done by placing the rocker arm in its vertical position, but, when there is no arm to so place, the one on the opposite side of the engine should be so adjusted and a measurement taken of the distance from the face of the steam chest to some well-marked point on the valve stem, such as the rocker arm pin hole or the key. The parts on the disabled side can then be set to the same measurements and clamped in position.

Care should be taken to measure from the face of the steam chest and not from the gland as the location of the latter is apt to vary.

*Q. What should be done in the case of a broken rocker box?*

A. This will depend to a great extent upon the nature of the break. If the box is in such shape that it can be removed, it will be best to do so, disconnecting the rocker arm from the link block and the valve stem, clamping the valve in the central position (page 18), taking down the main rod and blocking the crosshead (page 20).

If the rocker box cannot be readily removed, take down the eccentric rods and straps; clamp the valve and treat the main rod and crosshead as indicated above.

Should the box be so broken that it cannot hold the rocker arm firmly in position, the latter should be disconnected and removed.

*Q. What should be done in case a rocker pin breaks?*

A. If it is the upper pin the trouble should be treated in the same way as though it were a broken valve stem (see page 22).

If the lower pin breaks the upper pin should be removed and the rocker arm turned to the front or back as far as it will go and an examination made to see that it will clear the link in all positions of the latter. If it will, it may be tied there, as in Fig. 14, and the valve clamped (page 18), the main rod taken down and the crosshead blocked (page 20).

In case the rocker will not clear the link, it should be tied where it will be the least in the way, and the eccentric rods and straps removed; the other work being done as before.

Or, while it will be usually quite impossible to obtain a bolt that will exactly fill the hole in the arm or valve rod,

it will, however, sometimes be possible to procure one that will nearly do so, and by wedging about it with hard wood, to hold it steady, such a bolt may be made to do the work required in order to run the train to destination. The operation of such a bolt may be to somewhat injure the bushing with which it comes in contact, and the valve itself will not be moved exactly as it should be on account of the lost mo-

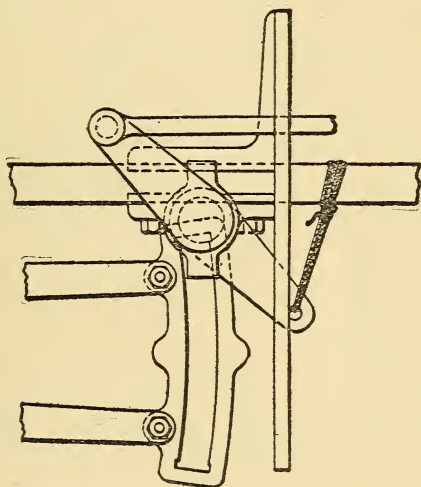

FIG. 14.—ROCKER ARM TIED TO FRAME TO CLEAR LINK.

tion of the parts, but this is of minor importance in comparison with the movement of the train, or the blocking of the tracks. This latter remedy is more readily applied and is preferable to the one first suggested.

*Q. What should be done if a link becomes broken?*

*A.* Remove the broken link and take down the eccentric rods and straps. The valve must be clamped (page 18), the

main rod taken down and the crosshead blocked (page 20). It will not, however, be necessary to disconnect the valve rod from the rocker arm.

*Q. What should be done in case of the breakage of the link block?*

*A.* The part should be removed and, after disconnecting the upper end of the rocker-arm from the valve-rod, an

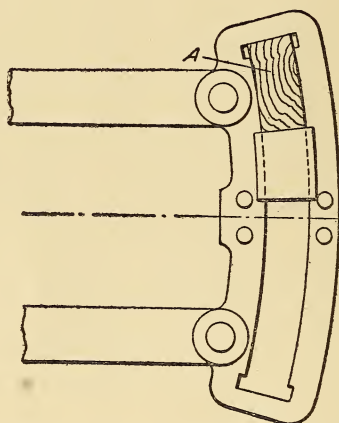

FIG. 15.—LINK BLOCKED AND HELD BY WOOD OVER LINK BLOCK.

examination should be made and the whole treated in the same manner as in the case of a broken lower rocker pin (page 36).

*Q. What should be done when a link saddle or saddle pin breaks?*

*A.* The link hanger should be removed, and the link lifted as high as it is desired to cut off and blocked on the link block, as shown in Fig. 15. The wooden block *A*

should be fitted tightly into position and may be held by light straps with a single bolt, although these will not be necessary.

When in this position the engine can be run forward but it should not be reversed as, in that case, the disabled side would be in the forward motion while the other would be in the backward.

*Q. What should be done when a link hanger breaks?*

A. Remove the broken part, and block the link in the same way and observe the same precautions as in the case of a broken saddle pin of the previous question.

*Q. When it becomes necessary to block up the link for any reason, as in the case of a broken link hanger, is there any objection to moving the other link by raising or lowering it?*

A. There is no objection to raising the link on the side that has not been disabled, but it must not be lowered beyond the point corresponding to that at which the disabled link has been blocked, because in most engines the link hanger is so short that the link just clears the end of the tumbling arm, and if this is lowered beyond the point corresponding to that at which the link is blocked, the two parts will be apt to strike and cause a more serious breakage than that which has already taken place.

*Q. How should a broken lifting arm be treated?*

A. Remove the link hanger and treat the combination in exactly the same way as for a broken hanger (see second question preceding).

*Q. What should be done in case a lifting shaft or its bracket is broken?*

A. In remedying this accident, the engine will be put into such a condition that it will be impossible to reverse it.

First disconnect the link hangers and reach rod and remove the lifting shaft. Then fit a block into the link slots on top of the link blocks, as shown in Fig. 15, so that the valves will cut off at the proper point for hauling the train. In addition to this fit a block beneath the link block, as in

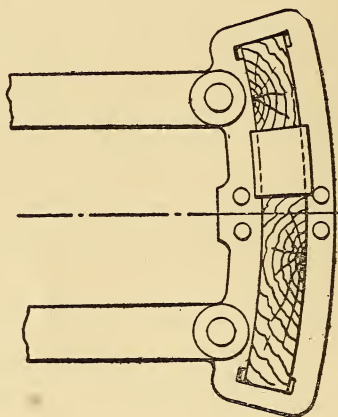

FIG. 16.—LINK BLOCKED AT TOP AND BOTTOM FOR BROKEN LIFTING SHAFT.

Fig. 16, to prevent slip. The engine can then be run forward and haul its train.

*Q.* What should be done with a broken link extension rod?

A. This is the rod sometimes used to connect the link block and rocker arm where it is not possible to bring them together. When such a rod breaks, it should be removed, the valve clamped in the central position (page 18), the main rod disconnected, and the crosshead blocked (page 20).

*Q. What should be done with a broken reach rod?*

A. The same class of remedy should be applied as in the case of a broken lifting shaft (page 40).

If it is possible to block the lifting shaft firmly in the running position this may be done. Care must be taken, however, that it cannot move in either direction. In case this cannot be done the link hangers should be removed and the lifting arms tied up clear of the links and the latter blocked in the running position, exactly as in the case of a broken lifting shaft, as described on page 40.

*Q. What can be done with a broken reverse lever?*

A. If the break occurs at the pin hole of the connection with the reach rod the accident should be treated in exactly the same manner as that of a broken reach rod.

If the break occurs below the reach rod connection the lifting shaft should first be blocked so as to lift the links into the running position. This takes the load off from the reverse lever. The reverse lever latch should then be put in the proper notch and fastened, so that it cannot be lifted out either by its own motion or the lifting of the reverse lever. The lower end of the lever should then be securely blocked in position. This can usually be done by fitting braces, as shown in Fig. 17.

If the lever is broken above the reach rod connection, the same method should be followed except that the latch will be useless and as the lower end of the reverse lever will be held by its own fulcrum, the bracing will hold the upper end. The latter condition is the more easily remedied of the two, and is illustrated in Fig. 18.

When the reverse lever has been firmly braced in position, the blocking for the lifting shaft should be removed.

When the construction of the engine is such that the lifting shaft can be blocked in position without interfering with

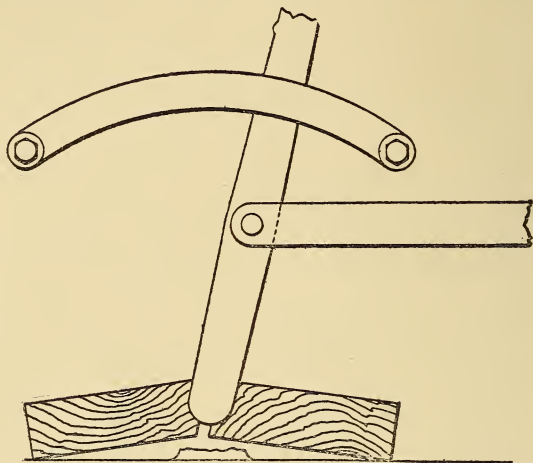

FIG. 17.—BLOCKING FOR BROKEN LOWER END OF REVERSE LEVER OR BROKEN REVERSE LEVER FULCRUM.

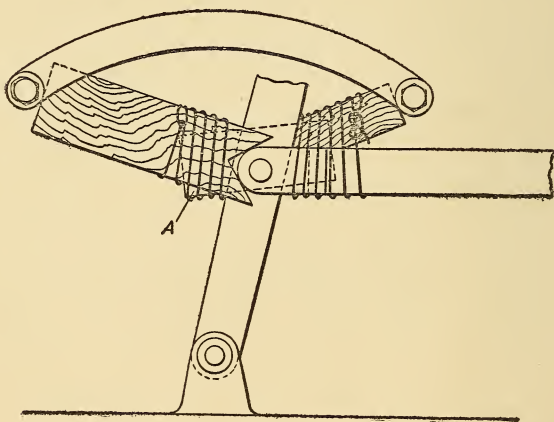

FIG. 18.—BLOCKING FOR BROKEN REVERSE LEVER.



the free movement of the eccentric rods, such blocking can be used and that of the reverse lever dispensed with. Such a condition is shown in Fig. 19, where it is possible to lay a plank across the top of the frames and lash it both to these parts and the lifting arms.

Under these circumstances it is better to use this remedy than that described for a broken reach rod on page 41.

*Q. What should be done with a broken eccentric rod?*

A. This may or may not cause the disablement of one

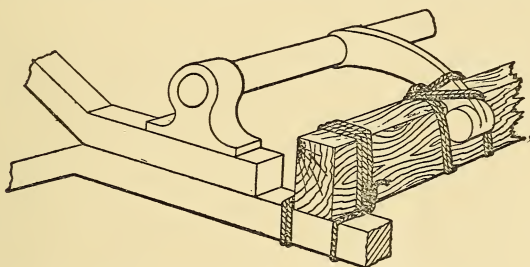

FIG. 19.—LASHING LIFTING ARM TO BEAM LAID ACROSS FRAME.

side of the engine. The broken rod or blade, together with the eccentric strap, may have to be removed or may not. In case the link is so hung that it can swing to and fro about the link block without striking any other parts of the framing or machinery, it will simply be necessary to remove the broken rod and proceed, if it is the backing rod that has failed. If it is the forward rod that has broken, it should be removed with its strap and the backing rod and strap put in its place. This of course makes reversing impossible and the reverse lever should be kept in full gear forward.

If, however, the link will not swing clear of the other

parts of the engine, the side upon which the break occurs will be disabled and the broken rod or blade, together with the eccentric strap, should be removed, the valve clamped in the central position (page 18), the main rod taken down and the crosshead blocked (page 20). In addition to this the top end of the link should be tied to the hanger to prevent it from tilting so that it will make it impossible to reverse the engine (see also page 45).

*Q. If the eccentric rod has merely slipped and has not broken what should be done?*

A. This accident will at once make itself known by causing an irregularity in the exhaust. It is easily remedied. Place the engine with the crank, on the side where the slipping has occurred, on the center, block the wheels, open the cylinder cocks and admit a little steam to the steam chest. Then drop the link down into full gear and adjust the rod that has slipped until steam just begins to come from the cock at the end of the cylinder where the piston is standing. That is to say, if the crank is on the forward center, until steam appears at the forward cock; or, if on the back center, until it appears at the back cock.

The rod should then be fastened and the work is done.

*Q. What should be done in case an eccentric is broken?*

A. This calls for practically the same remedy as the broken eccentric rod. The broken eccentric with both straps and rods must be removed and the other parts cared for as detailed in answer to the second question preceding.

*Q. What should be done in case an eccentric strap breaks?*

A. This need not necessarily disable one side of the engine. As it is usually the backing strap that breaks it will sometimes be found to be possible to remove the broken strap and clamp its rod to the other one, as shown in Fig. 20. When this is done the engine is ready to go ahead, but it cannot be backed and it must be borne in mind that the valve is working through its whole travel and with the maximum steam admission for all positions of the reverse lever, because both ends of the link are controlled by the same eccentric.

Should it be the forward motion eccentric strap that is

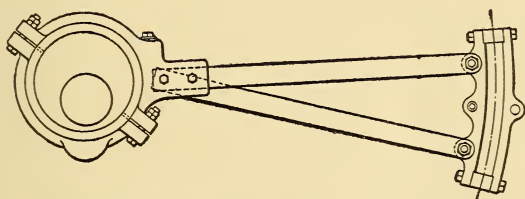

FIG. 20.—CLAMPING TWO ECCENTRIC RODS TOGETHER.

broken, the backing strap may be removed and put in its place, with the backing eccentric rod in place. The forward rod may then be attached to the bottom of the link and clamped to the backing. This, too, puts that side of the engine in full gear forward and it cannot be reversed.

This case can also be treated in the same manner as the case of a broken eccentric rod, as described in the answer to the question on broken eccentric rods, page 43.

*Q. What should be done in case an eccentric slips?*

A. This is an accident that is not apt to occur with the modern construction of locomotives where the eccentrics are

almost invariably keyed in position. It was, however, a common accident with the old type where the eccentrics were held in position by setscrews.

In the case of a slipped eccentric the engine should first be placed upon the center, the wheels blocked, the cylinder cocks opened, the reverse lever put in the full gear notch corresponding to the eccentric to be set and a little steam admitted to the steam chest in exactly the same way as in the case of a slipped eccentric rod that is to be reset (page 44).

The eccentric should then be turned on the axle until

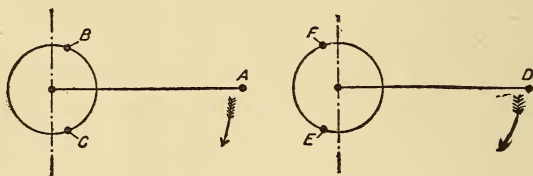

FIG. 21.—LOCATION OF ECCENTRICS RELATIVELY TO THE CRANK.

steam just begins to escape from the cylinder cock at that end of the cylinder where the piston is standing (page 44).

As there are two positions of the eccentrics in which this may occur, care must be taken that it is set in the proper one. In the ordinary construction of American locomotives with an upper and lower rocker arm the valve moves in an opposite direction to the eccentric rod, and the center of the eccentric follows the crank, as shown in Fig. 21, in which, when the crank A is moving in the direction indicated by the arrow, the controlling eccentric is at B. When moving in the opposite direction the controlling eccentric is at C.

Hence, in the readjustment of a slipped eccentric, care must be taken that it is set to follow the crank.

If, however, the rocker has two arms swinging together on the same side of the center and the valve moves in the same direction as the eccentric rods; then, the center of the eccentric leads the crank and, in Fig. 21, if the crank *D* is moving in the direction of the arrow, the valve will be controlled by an eccentric at *E*, while if it were moving in the opposite direction it would be controlled by one at *F*. This last also holds in the case of a piston valve with inside admission driven by a rocker that reverses the motion.

*Q. What should be done in case both eccentrics upon one side the engine are slipped?*

*A.* The engine should be put upon the center and the preliminary arrangements as to blocking the wheels, etc., be made as in the answer to the previous question. The reverse lever is then to be put in full gear forward and the forward eccentric adjusted as there described. This eccentric is then lightly fastened in position, and the reverse lever put in full-gear back. The same operation is then performed with the backing eccentric. After this has been fastened, the work should be repeated with the forward eccentric, as it will be found to be slightly out of place. The second adjustment will usually put it in its proper position. The work should then be checked by repeating it with the crank on the other center.

*Q. If an eccentric becomes hot, how can it be relieved without undue delay so that there will be no danger of breaking the strap?*

A. The quickest way will be to slacken the bolts holding the straps together and slip one or more thicknesses of tin between the two parts. This will relieve them so that a rapid cooling of the straps will not cause them to pinch and bind on the eccentric itself. If, however, the straps are badly worn, a liberal dose of valve oil capable of standing a high temperature may be put upon the hot parts.

*Q. Why is it necessary in disconnecting eccentric rods to remove the eccentric straps also?*

A. This is especially necessary in the old type of engine where the firebox was set down between the frames, because the distance from the center of the axle to the throat sheet was made so small that there was just clearance for the back of the eccentric strap, and if the latter were to turn with the eccentric it would strike the sheet and be apt to puncture it.

In modern engines other parts of the structure, such as the ash pan and braces, are located so close to the axles as to prevent the straps with their projections for the attachment of the rods, from revolving. Hence these straps must always be removed when the rods are taken down.

*Q. How are the valves of a locomotive set?*

A. It is a common fallacy among engineers to think that, because the operation of the Stephenson link motion is very easily understood and is simple in its construction, it can be tampered with with impunity. Nothing is further from the truth. A link motion that has been carefully designed in the drawing room must be considered as being fixed beyond any possibility of a change, unless the whole be redesigned

and adapted to the modification that it is desired to make. Engineers are, therefore, especially warned not to tamper with any of the parts of a motion; for any change in a well-designed construction is sure to be disastrous.

It should be borne in mind that each part has its own peculiar function to perform and, in order that it may do it properly, its position and dimensions must be fixed. It will not do, then, to vary the length of the link hanger or the position of the reversing shaft, to change the location of the saddle pin or the length of the lifting arms. Let these things alone until it has been positively ascertained that they are faulty, and that can only be done by a careful analysis of the design; an analysis that will be sure to point out the remedy as well as to locate the defect.

In the first place, it must be borne in mind that no link motion can be arranged to give an equality of cut-off at all points for both strokes of the piston. The most satisfactory design is one that provides for an equalization of the lead and cut-off in mid-gear, which will cause a variation of cut-off from  $\frac{1}{2}$  to  $\frac{3}{8}$  of one per cent in the full gear point of cut off and at other points, which is due to the slip of the link block, angularity of rods, etc.

In order to thoroughly understand the reasons for the various steps to be taken in the setting of the valves of a link motion, a few words may well be devoted to a description of its action. The link-motion is only used where it is desired to run the engine in both directions; in other words, it is a means of reversing the engine and finds its principal application in the locomotive and marine engine.

By referring to Fig. 22, it will be seen that there are two eccentrics  $A A'$  for driving the valve; one for each direction of engine rotation, whose rods  $B B'$  are coupled to the opposite ends of a curved link  $C$ , whose radius is approximately equal to the distance of its center of curvature from the center of the engine shaft. This link is supported by a hanger  $D$ , taking hold of a saddle pin  $F$  at one end, and being itself supported by a reversing arm  $E$  at the other.

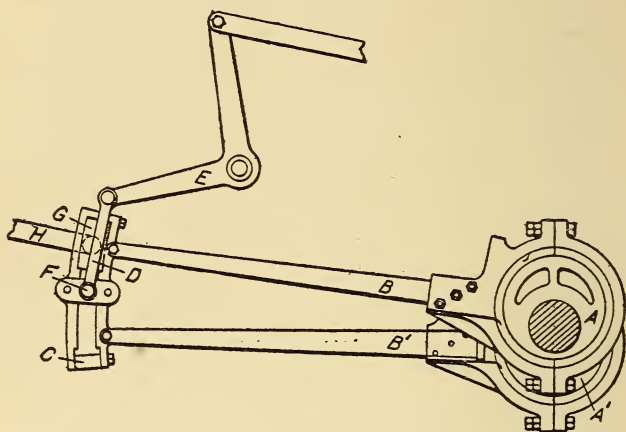

FIG. 22.—SIDE ELEVATION OF LINK MOTION.

A link-block  $G$  slides freely in the opening of the link and is attached to the valve-stem  $H$ , or to a rocker arm that, in turn, moves the valve-stem. It will be seen that, if the link is lowered until the link-block is opposite the connection of the eccentric rod  $B$ , that the eccentric  $A$ , which controls the movement of the upper end of the link, will have a much greater influence upon the motion of the block, and consequently upon the valve, than the eccentric  $A'$ . There-



fore, the valve will be driven almost wholly by  $A$ , and the engine will run in the direction corresponding to that eccentric.

Now, if the link be gradually raised, the influence of  $A$  will be proportionately diminished while that of  $A'$  will be increased, with the result that, when the central position is reached, the two eccentrics will have an equal influence, and the engine will not run in either direction. Continuing the raising of the link gives the eccentric  $A'$  a preponderating influence, with the result that the engine will run in the opposite direction from that which it would when the eccentric  $A$  was in control.

As the link approaches its central position on either side, the point of cut-off gradually shortens, a fact that has made the link-motion so valuable as a means of operating the valves, because the engine can be worked to admit steam for nearly the full length of its stroke, when starting, and can thus exert a maximum of power; while, after it has started, the position of the link may be shifted and the steam cut off at an earlier point of the stroke, thus being worked expansively with the economy resulting from such a method.

In the setting of the valves of a link-motion, the first thing to be done is to make an accurate measurement of the outside lap of the valve. Then set the valve in its central position. That is to say, so that the lap on each side extends an equal distance beyond the ports. When this has been done, make a small prick-punch on the flange of the stuffing box, as at  $a$ , Fig. 23, and, with a fixed tram

shaped as at *b*, make a punch mark at *c* on the valve-stem. It will always be possible, then, to set the valve in the central position even though the steam chest may be closed, provided the adjustment of the length of the valve-stem is on the outside. If the adjustment of this length is made inside the chest, the tram should be set as shown in dotted lines in Fig. 23, from the steam chest to the valve itself.

The next step to be taken, after placing the valve in its central position, is to adjust the length of the valve rod. If the valve is driven through a rocker, first set the upper

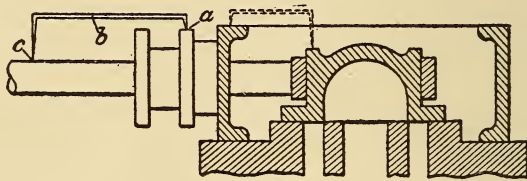

FIG. 23.—APPLICATION OF TRAM TO VALVE STEM.

arm so that it stands exactly vertical in the case of a horizontal engine, or exactly at right angles to the line of the valve rod if the latter is not horizontal. Then adjust the length of the rod so that the valve will be in the central position when the arm stands as indicated.

If the stem is attached directly to the link-block the latter should be attached to the rod, which should then be so adjusted that its center is distant from the shaft by the length of the radius of the link. This radius can be easily obtained by scribing its outline on a board and then finding the radius with a pair of trams. From this distance subtract half the

diameter of the shaft and measure out to the center of the block as shown in Fig. 24.

When the length of the valve rod has been accurately adjusted so that the link-block stands at the distance, just obtained, from the shaft, fasten both eccentrics in any position on this shaft, and dropping the link down to the extreme forward point of cut-off, turn the engine over and note whether the valve has an equal amount of travel on each side of its central position. If it has not, adjust the length of the eccentric rod *B* until such an equalization of travel is obtained. Then raise the link to the extreme backing

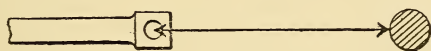

FIG. 24.—MEASURING POSITION OF LINK BLOCK RELATIVELY TO AXLE.

position and perform the same operation with the eccentric rod *B'*.

In order to check the accuracy of the work, drop the link into the extreme forward position again and make another test of the valve travel. The safest way to measure this travel is to use the tram and scribe a line on the valve stem or valve at the extreme point of travel, and measure from these lines to the center punch mark already referred to.

The motion is now ready for the setting of the eccentrics. To do this, first place the engine crank on the dead center. The best way to do this is to make a mark on the guides at the extreme point of travel of the cross-head. Then turn the engine back and come ahead again until the cross-head is

within an inch of its extreme point of travel. With a tram, Fig. 25, resting upon some fixed point of the engine, preferably the guide yoke or wheel guards, locate the point *a* on the side of the driving or flywheel. Then turn the engine ahead until the cross-head has passed the extreme point of travel and reached the same place as before, when a second point *b* is to be located at the same distance from the center of the axle as the point *a*. With a pair of dividers locate the point *c* midway between *a* and *b*. When the tram point rests upon the mark *c*, the engine will be on the center.

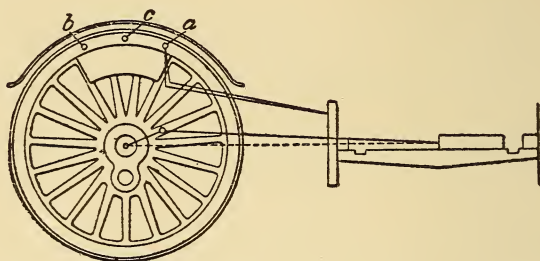

FIG. 25 —TRAMMING DRIVING WHEEL TO LOCATE THE DEAD CENTER.

The reason for not simply setting the engine on the center by the cross-head, is that the crank may be moved through an appreciable angle while passing the center and the motion of the cross-head be imperceptible. The method given locates the center exactly. The other center should be established in the same way.

In setting the eccentrics always turn the engine in the direction in which it is to move under the influence of the eccentric being set. This obviates a variation in the action of the valve due to lost motion in the parts.

The engine being now placed upon the center, drop the link into its extreme forward position. Loosen the eccentric. If the link-block is attached directly to the valve rod, the eccentric leads the crank; if a rocker arm is used the eccentric follows the crank. Turn the eccentric accordingly, until the valve is opened by the amount of lead that it is desired that it should have and then fasten it in position. Raise the link to the backing position and set the other eccentric in the same manner. Again drop the link to the forward position and see if the lead has been changed by the adjustment of the backing eccentric. If it has, readjust the forward eccentric to suit the case, which means re-set it under the same rule as before.

Finally, turn the crank to the other center and see that the same lead is given there. If not, first go over the length of the valve rods and eccentric rods to ascertain that they are all right and then, if the valve motion is properly designed, the lead will be the same. In case this does not occur, then lengthen or shorten the eccentric rod as the case demands so as to secure an equal lead.

Under no circumstances make any change in the dimensions of the fundamental parts without first making a careful analysis of the whole mechanism, and if a fairly even cut-off cannot be obtained by following the rules laid down, it is certain that the fault lies in the design. It will be seen that extreme simplicity is characteristic of the setting and operation of the valves, but it is a simplicity that is fixed in the mutual relationship of the several parts.

### CHAPTER III.

#### **Accidents to Cylinders, Steam Chests and Pistons.**

*Q. What should be done in case a piston breaks?*

A. It would rarely happen that a piston would break without doing other damage to the cylinder. In case, however, such an accident should occur the front cylinder head should be taken off and the broken parts removed. The valve stem should then be disconnected from the rocker and the valve clamped in the central position (page 18). The main rod must be taken down and the cross-head blocked.

*Q. What should be done in the case of a broken piston rod?*

A. This accident almost invariably results in the knocking out of the front cylinder head. Usually there is little or no damage done to the cross-head. It is, therefore, only necessary to remove the broken parts, disconnect the valve stem from the rocker and clamp the valve in the central position (page 18).

In case the breakage is such that the cylinder is emptied, as would occur when the break takes place close to the cross-head, it will not be necessary to take down the main rod, but the cross-head can be allowed to play back and forth in the guides while the locomotive is being driven from the other side.

Should the break occur at such a point between the cross-head and the piston that the stub end of the rod attached to the cross-head would enter and leave the stuffing box, it will

be necessary to remove the same or disconnect the main rod and block the cross-head (page 20).

*Q.* Why is the alternative presented in the answer to the preceding question of removing the broken piston rod from the cross-head or taking down the main rod?

*A.* Because the piston rod is usually fitted so tightly into the cross-head as to make it impossible to remove it with the appliances available on the road.

*Q.* How is this removal usually effected?

*A.* There are a number of special tools designed for this

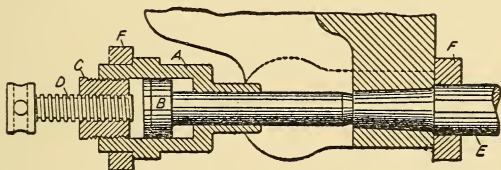

FIG. 26.—HYDROSTATIC PISTON ROD REMOVER.

purpose. A simple way is to use a wedge driven in and bearing against the rod and a seat resting against the wrist pin. Some kind of hydraulic jack is, however, the most satisfactory method of doing the work. Such an apparatus is shown in Fig. 26. It consists of a cylinder *A* bored out to receive a plunger *B*, which is fitted with a leather cup packing. The opposite end of the cylinder is closed by a plug *C*, which also serves as a nut for the screw *D*. The action of the device is as follows: The space between *B* and *C* is filled with white lead or oil, preferably the former, as it is less apt to work out around the screw *D*. The plunger *B* is set up against the end of the piston rod *E* and the holding

bolts between the plates *FF* drawn snugly home. The screw *D* is then turned by means of a long lever, thus producing a hydrostatic pressure upon *B* and forcing out the piston rod. The plates *FF* are held together by bolts not shown in the drawing and serve to prevent the cylinder *A* from moving off before the pressure exerted on *B*. This device puts no stress other than compression on the cross-head.

*Q.* What should be done when a cylinder head is broken?

*A.* If the forward head is broken the main rod should be taken down and the cross-head blocked (page 20). The

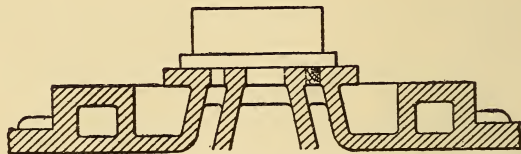

FIG. 27.—METHOD OF BLOCKING PORT FOR BROKEN CYLINDER HEAD.

valve stem should be disconnected and the valve clamped in the central position (page 18).

If it is the back head that is broken it is more than probable that the guides will also have been carried away. It will then be necessary to strip one side of the engine of the guides, cross-head and connecting rod.

*Q.* Is it possible to so repair an engine with a broken front cylinder head that a disconnecting of the valve will be unnecessary?

*A.* Yes. It is possible to remove the steam chest cover, and fit a piece of wood tightly into the forward port, as shown in Fig. 27. This will prevent the escape of steam



when the valve travels over the wooden filling. When this has been done, the steam chest cover may be replaced and the engine run on that side as a single-acting machine. That is, taking steam at the back end of the cylinder only.

The objections to this method are, first, the amount of time that will be required to do the work, with the resultant delay to trains and the blocking of the track, and second that the movement of the piston to and fro in an uncovered cylinder, where it will be exposed to the flying dust and dirt, will be apt to cut the shell and do more harm than the slight saving in power available in the disabled engine will amount to.

*Q. What are the causes of broken cylinder heads?*

A. A broken cylinder head at one end or the other will almost invariably result from a breakage of a crank pin, main rod, cross-head or piston rod. This class of accident also frequently occurs as the result of a piston rod key working loose, or a follower bolt dropping off and serving as an obstacle to the free traveling of the piston to the end of its stroke. Another cause that leads to frequent breakages of this kind is the accumulation of water in the cylinders. When an attempt is made to start a locomotive, after it has been standing for a time, the steam entering the steam chest and cylinders will be condensed in such quantities that unless the cylinder cocks are open, enough may accumulate in the clearance space between the piston and cylinder head to break the latter or bend the former.

*Q. How can broken cylinder heads be prevented?*

A. Where they are the result of the breakage of some of the parts enumerated in the answer to the previous ques-

tion, a prevention is impossible, but they may be prevented, when due to an accumulation of water of condensation, by having the cylinder cocks open and admitting the steam so slowly, on starting, that the cylinders will be well heated and steam, not water, be blowing from the cylinder cocks before the engine moves.

*Q. What should be done with the cylinder cocks of a disconnected engine?*

A. It is best to remove them or block them open on the disconnected side. The reason is that it is desirable that no pressure shall be exerted against a piston whose cross-head is blocked. As there is always danger of the valve leaking the safe course to pursue is to have the cylinder cocks open. As it is usually desirable to close them upon the working side of the engine, those in the disabled side had best be disconnected or blocked open.

*Q. When a cylinder is broken what should be done?*

A. The exact course to be pursued will depend solely upon the extent of the damage done. If the breakage consists merely of a crack, it may be possible to continue on to destination without doing anything more than observe extra precautions to see that the injury does not increase to an extent that will imperil the safety of the train.

If a piece is broken out of one end of the cylinder, the remedy to be applied may well be the same as that used in the case of a broken cylinder head, as described in the answer to the question on page 58.

If the accident is such that the cylinder is demolished on one side and the other remains intact, the crippled engine

may still be sent home under its own steam. To do this remove the main rod cross-head and guides from the disabled side. Disconnect the valve rod and remove it. Finally open the front end and loosen the steam pipe and slip a piece of sheet metal into the joint and then tighten the latter. This will cut off the flow of steam to the disabled cylinder when the throttle is opened for the operation of the other side (see also steam chest, page 62).

*Q. What are the causes of natural deterioration of cylinders?*

A. The movement of the piston to and fro produces a wear that, in time, necessitates reborings in order to bring the interior back to a cylindrical condition.

*Q. How is this reborings done?*

A. Usually by means of a portable boring bar that is placed in the cylinder while it is in position on the frames, and is driven by some elastic or portable means of power transmission.

*Q. Is there any objection to this reborings of cylinders?*

A. Repeated reborings may make the walls of the cylinder too thin to withstand the internal pressure of the steam, or, if the original diameter of the cylinders was such that the tractive power developed was fully up to that corresponding to the adhesion due to the weight on the driving wheels, the extra tractive power developed, as the result of the increase in diameter, may make it very difficult to prevent the wheels from slipping whenever an attempt is made to start the engine. This difficulty may, however, be prevented by inserting a bushing into the rebored cylinder.

*Q. How is such a bushing prepared and applied?*

A. It is made of cast iron and is turned on the outside so that it will require some pressure to force it into position. The interior is bored to the diameter which it is desired to give to the piston and cylinder. The length is so made that the bushing will have a bearing against each cylinder head and be held in position by them in addition to the frictional resistance to motion due to the pressure with which it is put in place. Such a bushing is usually forced in with heavy bolts and screws.

*Q. What remedy should be applied to a broken steam chest?*

A. First remove the casing and ascertain the extent of the fracture. If it is merely a crack upon one side, it may be possible to so close it by wedging between the outside of the chest and the bolts that the parts will be cramped and pressed together enough to prevent an excessive amount of leakage.

If the crack is too large to be stopped in this way or if there is a piece broken out, the steam chest had best be removed, the valve stem and main rod disconnected and the cross-head blocked (page 20). It will then remain to stop the passages to prevent the escape of steam when the throttle is opened. The simplest and quickest way to do this will probably be to fit pieces of board over the steam passage and hold them down with the steam chest cover as shown in Fig. 28. Here the boards *B* are held down by the blocks *A*, against which the steam chest cover *C* is to be firmly screwed.

Another method of cutting off this flow of steam is to slacken the bolts holding the steam pipe to the saddle and slipping a sheet of metal into the joint, as already described in the answer on page 61. The objection to this latter method is the difficulty of doing the work. The bolts holding the steam pipe are apt to be corroded and difficult to loosen

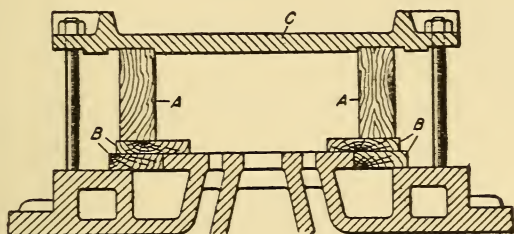

FIG. 28.—METHOD OF BLOCKING STEAM PASSAGES WITH  
BROKEN STEAM CHEST.

while the heat of the smoke box will render the work slow and arduous.

*Q. What should be done when a steam chest cover is broken?*

A. The results, as far as the engine is concerned, are practically the same as when a steam chest is broken. The same work of preparation must be done in the removal of the main rod, the blocking of the cross-head, and the closing of the steam passages after the valve has been removed from the steam chest.

The method to be pursued in holding this blocking in position will depend upon the condition of the cover. If enough of it remains to enable it to be used for holding

down the blocking as shown in Fig. 28 this should be done. If it is too badly broken for this, then a stiff plank should have holes cut in it to fit over the studs and be used in its place, or the steam chest box itself may be raised and the boards slipped beneath it and the nuts then be run down upon its upper surface, as shown in Fig. 29, which will also entail the use of the stuffing box cover, as in Fig. 7.

*Q. What is a common cause of the breakage of steam chests and covers?*

A. The reversing of the engine when running at high

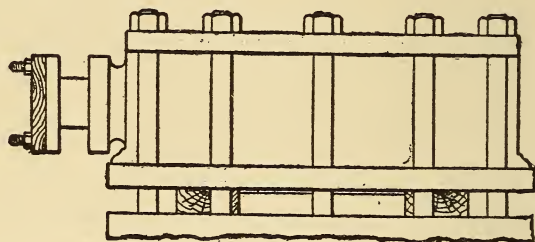

FIG. 29.—CLAMPING BOARD OVER PORT WITH STEAM CHEST.

speeds. This converts the pistons into air pumps that force the air into the steam chests very rapidly and may create a pressure there that is quite capable of bursting them.

*Q. How can this accumulation of pressure and the consequent bursting of the steam chests be prevented?*

A. By opening the throttle valve slightly when the engine is reversed. This makes it possible for the excess of pressure that would otherwise accumulate in the steam chest to escape back through the dry pipe, into the boiler, and if necessary out at the safety valve.

*Q. What effect may wear have upon the tightness of split spring ring piston packing?*

A. The theory of the action of split ring spring packing is that it is held out against the walls of the cylinder by its own tension and that the pressure is increased by the action of the steam upon the inside surface, forcing it out. The result of this is that, after the engine has been run for a time, the packing may be so worn that the steam will force it out beyond the point where its own natural elasticity would carry it. When this condition is reached the packing will draw away from the walls when there is no steam or steam of a low pressure in the cylinders. Under such conditions, it sometimes happens that the packing will be tight when the engine is taking steam at full stroke or when the maximum boiler pressure is maintained. But, when the reverse lever is drawn back and the cut-off takes place early in the stroke, the steam pressure falls, by expansion, to such an extent at the end of the stroke that the rings will draw away from the walls of the cylinder and cause a blow and rattle while running over the road, but which would not occur when starting.

*Q. How can blows caused by the wear of the piston rings and due to the failure of the steam to always hold them out in contact with the walls, be best detected?*

A. By testing the rings for blows when the steam pressure in the boiler is low.

*Q. If the movement of the piston in the cylinder causes a groaning, how can it sometimes be remedied?*

A. By putting some flake graphite in through the relief

valves occasionally. This should be done about once every hundred miles.

*Q. Where rod bolts have been partially sheared and they cannot be driven out, how can they sometimes be removed?*

A. Put the crank on the lower quarter and place a jack beneath the sticking bolt, and tighten up hard. Place a nut or ring over the head so that a blow delivered upon the same from above will come against the rod or strap. Do not strike directly upon the strap. If this fails to start the bolt, take a shovelful of coals from the firebox, and, with the shovel held at an incline, allow them to lay against the side of the rod. After a few moments the heat will so expand the metal of the rod that the bolt can usually be easily driven out.

*Q. In the adjustment of spring ring packing on the pistons of cylinders, what precaution should be taken in regard to the tightness of the same?*

A. Care should be exercised that these rings are not set out too tightly. It is, of course, undesirable that they should be so slack that they are not brought into contact with the walls of the cylinder with sufficient force to make a steam-tight joint, but a leak is preferable to having them forced out with so great a pressure that they will cut the cylinders. It should be borne in mind that when metal-to-metal contacts are secure, it does not take an excessive pressure to make a steam-tight joint.



## CHAPTER IV.

### **Accidents to Guides, Cross-Heads and Rods,**

*Q. What should be done in case a guide breaks?*

A. This is an accident that very rarely happens except as the result of the breakage of some other part, such as a cylinder head, by which the guide is torn from its fastenings. When it does happen, the valve stem is to be disconnected and the valve blocked in the central position (page 18) and the main rod taken down.

The disposition that is to be made of the cross-head will depend upon the condition of its connecting parts. If the piston rod has not been bent or has not been injured to such an extent as to prevent the piston from being pushed to the front end of the cylinder, this may be done and the cross-head tied against the cylinder with a bell cord. The piston rod will be able to support it in this position and the tying will prevent it from turning. If this cannot be done the cross-head should be removed from the piston rod, and the piston blocked in the back end of the cylinder if it cannot be removed.

To block the piston in the back end of the cylinder, take off the front cylinder head and fit in a piece of board that will have a bearing against the piston and the cylinder head when the latter is replaced, as shown in Fig. 30.

*Q. In the case of an engine having four-bar guides that persistently run hot, what can be done to remedy the difficulty?*

A. It frequently happens that the guides are set too close to the cross-head, and when the latter is in motion it may become heated. This expands the cross-head and causes an increase of the tightness, resulting in hot guides. The remedy is to loosen the latter and separate them by the interposition of a thin liner between them and the blocks. This is a remedy, however, that belongs to the shop and should not be

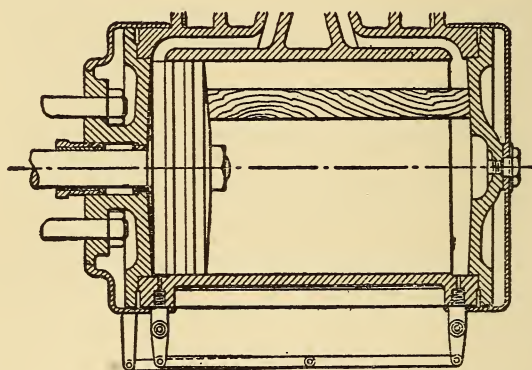

FIG. 30.—BLOCKING OF PISTON WITH BOARD INSIDE OF CYLINDER.

attempted on the road except in cases of extremity, because of the liability of getting the guides out of line.

*Q. What should be done with a bent or broken guide yoke?*

A. This is also an accident that usually follows in the train of some other one. If the condition is such that it cannot be made to hold the guides in proper alignment, the valve stem should be disconnected and the valve clamped in the central position (page 18). The main rod is to be

taken down and the cross-head blocked (page 20). In case the guide yoke is so injured that it distorts the alignment of the guides upon both sides, the rods and valves must be disconnected on both sides and the engine towed in.

*Q. What should be done with a broken cross-head?*

A. This accident will involve the disconnecting of one side of the engine, removing the main rod and clamping the valve in the central position (page 18). The balance of the work to be done will depend upon the condition of the break. If it is slight so that the cross-head can be blocked, as described on page 20, this should be done.

If, however, the cross-head is too badly broken for that, it should be stripped clear of the piston rod, and the piston blocked in the cylinder as described in answer to the question on page 67.

*Q. Suppose a gib only of the cross-head is broken, what can be done?*

A. It may be quite possible to go on without disconnecting the engine. It is supposed, however, that the gib is broken or destroyed. The action to be taken will depend upon which gib is broken.

When an engine is running ahead the cross-head is pressed upward on both strokes by the push and pull of the connecting rod. If, then, it is a gib on the lower bearing surface of the cross-head that is broken, it may be replaced with a piece of hard wood set into its place, so as to prevent the cross-head from dropping when it passes the center. This gib will enable the engine to be backed as well as run ahead.

In case it is the top bearing gib that is broken, the first

thing to be done will be to ascertain whether the lower gib can be removed and substituted in its place. If it can, it should be done, and a wooden gib used as before.

If such a substitution cannot be made a hardwood gib can be put in the place of the one that is broken and the engine run slowly ahead.

Great care must be exercised in the performance of this work to have the gib sawn as true as possible. It should also be thoroughly saturated and soaked in oil before it is put in position to prevent rapid wearing. The engine should also be stoppēd at frequent intervals for inspection to see that the wear has not been so great as to endanger the piston rod by springing.

If a sheet of lead is available to lay over the bearing surface of such a gib it will make it possible to run continuously and at moderately high speeds.

There is usually but little choice of woods when such repairs are to be made. But if such a choice is offered apple wood should be preferred to any other. In general the denser the wood the better it can be made to serve this purpose.

*Q. What course should be pursued when a wrist pin breaks?*

A. This is practically an accident similar to the breaking of a cross-head where the blocking of the same is still possible and should be treated in like manner (see page 69).

*Q. What should be done in case of a broken main or connecting rod?*

A. This is an accident that is usually of a serious char-

acter and rarely occurs, when the engine is running, without causing the breakage of other parts as well.

The other injuries that are liable to result from this accident are the breakage of one or both cylinder heads, due to the admission of steam at the ports by the movement of the valve before the engine can be stopped, and the bending or breaking of the main crank pin and side rods.

In any event the engine is disabled upon one side and the valve must be clamped in the central position (page 18) and the cross-head blocked, or removed according to the consequential damage that has been suffered. The parts of the main rod must be removed. A careful inspection should be made of the side rods to ascertain whether or no they have been bent or injured.

If there is the slightest indication of any injury having been done they should be removed from both sides of the engine (see page 72).

*Q. What should be done when a main rod strap breaks at either the front or back end of the rod?*

A. This is practically the same thing as the breakage of the main rod and should be treated in the same way (see the preceding question).

*Q. If the setscrews or nuts holding the keys of the main rod are lost or broken what should be done?*

A. The loss of the setscrew is not a serious matter, as the nuts at the bottom of the key will usually serve to hold it in position. There need, then, be no diminution of speed on that account, as the setscrew is merely an extra precaution.

If, however, the nuts on the bottom of the key are lost, care should be exercised and watchfulness maintained to see that the setscrew is held tightly in position and does not work loose.

If both setscrews and nuts are lost, there is nothing but its own frictional resistance to hold the key in position and the setscrew should be taken from the other rod and used. Failing this the engine should be run very slowly.

*Q. What should be done when a main crank pin breaks?*

A. The valve must be clamped in the central position (page 18), the main rod on the broken side removed and the cross-head blocked. The side rods must also be removed from both sides of the engine (see second question following).

*Q. What should be done when a side rod breaks?*

A. This, like the breakage of the main rod, is apt to cause a great deal of consequential damage to the locomotive, especially to the cab.

It is possible that this accident may occur and do no damage to the main crank pin or the main rod. In such instances the side rods on both sides of the engine are to be taken down and the engine run carefully to prevent slipping.

If the main crank pin or main rod is bent or injured it must be taken down, the valve clamped in the central position (page 18), and the cross-head blocked.

*Q. Is it necessary to take down the side rods upon both sides of the engine when one is removed, and if so, why?*

A. It is necessary, and the reason is that the trailing wheels are turned in unison with the main driver by the side rods. If one rod is removed, then the other side rod can

exert no turning influence at all upon the wheel when the crank is passing the dead points. If a stop is made at or near these points, an enormous stress may be put upon the rod when starting, especially if the main drivers should slip. Such a stress would undoubtedly break the rod. In addition to this it might be quite possible, owing to lost motion in the parts, for the main driving wheel crank to have reached or passed the dead point while that of the trailing wheel had not reached it. Under such circumstances it can readily be seen that a forward movement of the main driving wheel might tend to roll the rear wheel backward.

It, therefore, stands as accepted practice from which no deviation is allowable under any consideration, that, if the side rods are removed from one side of an engine, they must be removed from the other side also.

*Q. What should be done in case the side rod of a tandem connected engine breaks? By "tandem connected," is meant an engine upon which the eccentrics are not upon the main driving axle driven by the connecting rod.*

*A.* In accordance with the answer given to the previous question, it is necessary to remove the side rods from both sides of the engine if that upon one side breaks. Therefore, if one rod connecting the main driving axle with the one carrying the eccentrics breaks, it will be necessary to take down its mate upon the other side of the engine. Under these conditions there will be no means of causing the axle with the eccentrics to revolve in unison with the main axle and the engine will be helpless because of the impossibility of keeping the valves in harmonious motion with the piston.

Under these conditions, then, it will be necessary to take down both sides of the engine, block both cross-heads, deaden or extinguish the fire and tow the engine to the shops. If the distance is short the valves may be left connected, but if it is so great that they will be apt to cut themselves and their seats if left free to move under the action of the eccentrics, they, too, should be disconnected and clamped. It is, of course, evident that, if the valve on neither side can be worked, the engine is helpless.

*Q. What is the reason for the breakage of side rods?*

A. It is due to two causes: one is the end thrust to which they are subjected on account of the work of transmission that they are called upon to perform. This amounts to the total thrust of the pistons less the adhesive resistance of the main driving wheels. The other cause is the centrifugal action of the moving rod. This force is the equivalent of an evenly distributed load over the whole length of the rod. It is dependent upon the weight of the rod and the speed of the engine. It is evident, then, that the longer the rod and the higher the speed the greater will be the stress upon the metal. This latter is probably the principal cause of side rod failures, and explains why there are more failures on passenger than on freight engines as exemplified in those that occur on eight-wheelers or 4-4-0 engines as compared with moguls (2-6-0) and consolidations (2-8-0).

*Q. If a section of a side rod breaks upon a six or eight wheeled connected engine of the ten-wheeled, mogul or consolidation types of engines, is it necessary to remove all of the side rods?*



A. No. If the rear section of such rods break it will merely be necessary to remove the section opposite it, and the engine can be safely run with the forward sections in position. In like manner if any other section is broken the one opposite it only need be removed. Thus in consolidation engines with the side rods made in the usual way, if the rear or front sections are broken, it is quite possible to run with the middle and other uninjured sections in position. But if the middle section is broken it will usually necessitate removing the front and rear sections so that the whole of the side rod must be removed from both sides of the engine.

What can be done under these conditions will depend upon the location of the knuckle. It is usually in the straps of the middle section for both front and back rods. Under these circumstances the disconnecting may be done as outlined above. If, however, the knuckles are placed ahead of the pins, that is to say in the forward straps of the rear and middle sections, then a breakage of the rear section will necessitate the removal of all of the side rods on both sides because the break in the back section involves taking down the middle section, and this, in turn, requires the removal of the front one.

*Q. In the case of a four-wheeled switching engine will it always be possible to run it under steam with the side rods down?*

A. No. Some of these engines are so built that the crank pin of the forward wheel will strike the cross-head unless the two are run together as when everything is in position. In engines of this class, when a side rod breaks, it

will be necessary to take down both side rods and both connecting rods, clamp the valves (page 18) and block the cross-heads in the forward position (page 20). The engine must then be towed in.

The same thing holds true of some moguls, whose forward crank pin would strike the cross-head under the same conditions of independent action.

*Q. How should side rods be keyed?*

A. The engine should be run upon a straight and level piece of track and placed accurately upon the centers. The wedges should be so adjusted that the axles stand parallel to each other and at right angles to the frames. It is also well to have the engine under steam when this work is done so that the frames may be expanded by the heat of the boiler the same amount that they will be under working conditions.

After the engine has been put in position all of the keys in the rods to be adjusted should be slackened. The main bearing should then be keyed first, and the work done so that it can be easily moved to and fro by hand. The other bearings should then be keyed in succession on either side of the main crank pin.

The engine should then be moved to the quarters and the other center and a trial made to see that the brasses can still be easily moved on the pins. If they can, the work has been properly done.

The reason for placing the engine on the center when doing this work is that it is at this point that the greatest stress is put upon the rod, and there is no chance for the

adjustment of distances as there is at other points of the revolution.

Another point to be borne in mind is that it is better to have the brasses keyed too loosely than too tightly. The rods may rattle and make a noise under such conditions, but the bearings will not heat nor will the rods themselves and the crank pins break.

On the modern four-coupled engine the rods are put up with solid brasses bored about 1-64 inch larger than the pin so that there is no possibility of changing the adjustment of the brasses by keying.

*Q. What precaution should be taken in inspecting side and main rods to avoid the danger of breaking?*

A. The break is apt to occur in the corners of the straps and the actual rupture will usually be preceded by a crack that gradually works out through the metal from the inside until the part is so weakened that it is unable to withstand the regular working stress. In examining the rods, therefore, these parts should be most carefully inspected for any incipient crack that may appear. Such a crack will be readily detected if the rod is wiped clean, but will be invisible on one that is covered with oil and dirt, especially if the former is dried and caked.

## CHAPTER V.

### **Accidents to the Running Gear.**

*Q. What should be done if a driving axle breaks?*

A. The breakage of a driving axle is apt to be a serious mishap to an engine. The fracture usually occurs just inside the hub of the wheel. The result is that if the engine is running at anything more than a very low speed and the main driving axle breaks the wheel will leave the rails and carry all of the connections with it, stripping the side of the engine upon which it is located of side and main rods, and possibly causing the piston to knock out a cylinder head.

In the case of the breakage of a trailing axle the accident may be restricted to the breaking of a side rod in addition to the loss of the wheel. This accident is also apt to cause a derailment.

There are, however, instances on record, where the engine was moving slowly, that an axle has broken and not injured any of the rods and the wheel has remained upon the rail. In case the engine is not derailed, the first thing to be done is to strip off the connections. If it is a main driving axle, then the connecting rod upon the broken side and the side rods upon both sides must be stripped, and the valve and cross-head blocked. The condition of the break will be the guide as to whether it will be safe to move the engine under its own steam. If all parts are in good condition after the rods have been removed, the engine may be moved under its own steam, but it must be done very slowly and very cautiously.

This may be done to get it on to a siding in order to clear the main track, but for a long run to the shop, the remaining connecting rod should be taken down and the engine towed in.

Where the breakage is that of a rear axle, it may then be possible to disconnect and still leave both main rods in position. Under these circumstances the engine may be run slowly for long distances with safety.

Before moving the engine, however, it is necessary to block up the axle. This may be done in either one of two ways: by blocking up the oil cellar as high as it can be raised after jacking up the axle. This blocking is done by driving wedges in between the bottom of the oil cellar and the pedestal brace, as shown in Fig 31. In addition to this the equalizer should be pried into a horizontal position and a block driven in to hold it there. If the equalizer and springs are on top of the frames this is an easy matter, as the block will be driven in between the top of the frame and the end of the equalizer.

If the equalizer is below the frame the end should be chained up to the lower rail, as shown in Fig. 32.

Should it be the main axle that is broken this blocking will carry the engine by thus throwing the load upon the rear wheel. If it is the rear axle that is broken it will be well to jack up the rear end of the engine, and chain one or two pieces of rail to the frame and allow the back ends to rest on the tender frame, as shown in Fig. 33. Then, when the engine is lowered, they will take a portion of the load and transfer it to the tender.

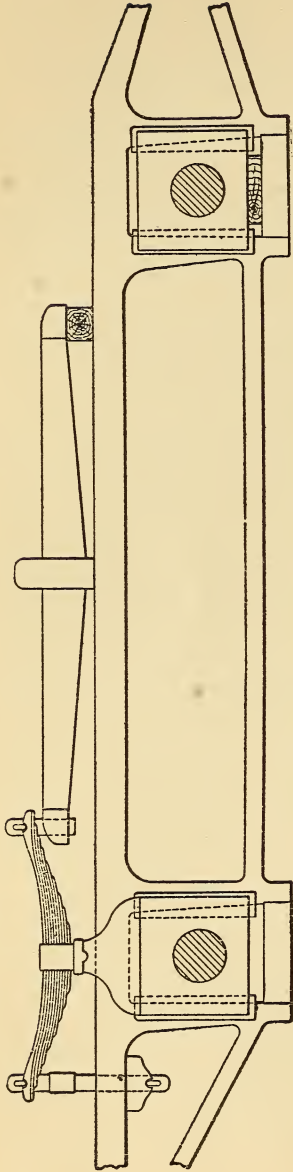

FIG. 31.—METHOD OF BLOCKING FOR BROKEN DRIVING AXLE.



FIG. 33.—HOLDING UP REAR END OF ENGINE WITH RAILS CHAINED TO FRAME AND TENDER FOR BROKEN REAR DRIVING AXLE OR WHEEL.

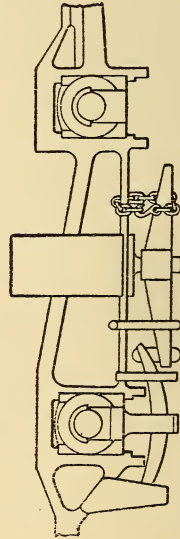

FIG. 32.—CHAINING UNDERHANG EQUALIZER WHEN MAIN DRIVING AXLE IS BROKEN.

In case the breakage occurs on a consolidation engine the oil box that is to be blocked up may be relieved of its load by running the rear wheels up on wedges. This lifts the frame and renders the blocking more easy.

*Q. What should be done in case a driving wheel breaks?*

A. This is an accident that may be practically identical in its results as a broken axle. If it is a trailing wheel that is broken the side rods connected to it and its mate must be removed, and in the case of a main wheel, the connecting rod must be treated in the same manner. The latter, of course, involves clamping the valve (page 18) and blocking the cross-head (page 20).

The condition of the wheel will govern the method of treatment. If it is so weakened that it cannot carry any load, it should be blocked up clear of the rail, just as in the case of the broken axle described in the previous question. There is, however, a difference to be observed in the blocking. In the case of the broken axle it was recommended that the oil cellar be blocked up leaving the journal free to turn upon it. Such treatment will result in the cutting of the journal; but, under the circumstances, this is a matter of no moment, as the axle will be scrapped anyhow.

Where the wheel is broken, it may be desirable to protect the axle and so it will be best to remove the cellar from the oil box and fit a piece of hard wood snugly in over the top of the pedestal binder to serve as a rest for the axle and wheel, as shown in Fig. 34. In other respects the accident is to be treated like that of a broken axle, as in the previous question.

*Q. What should be done if a driving wheel tire breaks?*

*A.* This accident may or may not seriously disable the engine. Sometimes the breakage of a tire, when running, strips off the rods on one side of the engine as completely as if the axle or wheel had broken. At other times the tire merely cracks and remains in position on the wheel.

In the latter case, it is frequently possible to run the engine to the terminal without taking down any of the rods. Great care and watchfulness must, however, be exercised while doing this and the engine must be run very slowly. It is recommended, however, that if the break occurs on a trailing wheel, the side rods be removed. This will not only lessen the stress on the tire by relieving it of all driving action, but will give it an opportunity to fall clear of

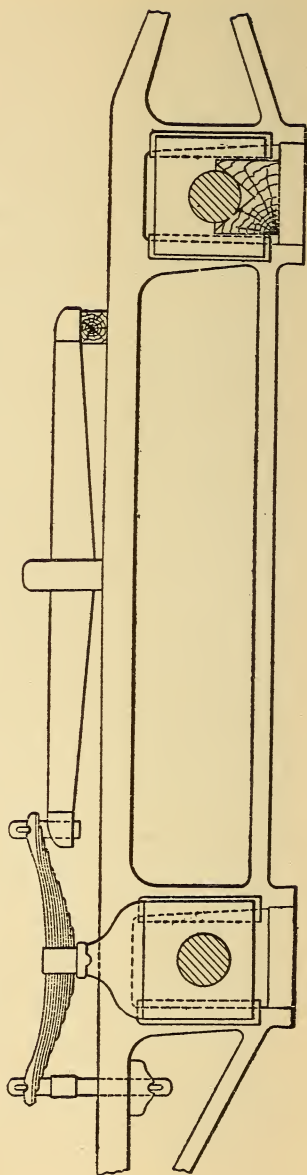

FIG. 34.—BLOCKING UP AXLE WITH BROKEN DRIVING WHEEL.



the engine without doing any damage in case it does come off. If the tire has been thrown off and has stripped the rods from one side of the engine, the case must be treated in the same manner as a broken axle or a broken wheel in the previous question.

*Q. What should be done when the main tire on a standard eight-wheeled engine breaks?*

A. The wheel should be jacked up clear of the rails, the oil cellar removed and a block driven in over the pedestal brace to carry the axle, as in Fig. 34. The rods should be removed. It is also well to take off the driving springs, and block up over the rear axle box beneath the frame so as to raise the latter to such a height that the center from which the tire is broken cannot come down against the rail.

*Q. What should be done when a rear tire on a standard eight-wheeled engine breaks?*

A. The axle should be blocked up in the same way as when the main tire is broken (see four preceding questions).

*Q. What should be done when a forward tire breaks?*

A. Treat the same as in the second question preceding.

*Q. When an axle, wheel or tire breaks on a standard eight-wheeled engine and the blocking is done as directed, how is the weight of the engine distributed?*

A. If it is the rear axle, wheel or tire to which the accident has occurred, the front axle will be loaded with the weight previously carried by itself and the rear wheel with something more on account of its location ahead of the point of equalizer suspension and nearer to the center of gravity. For this reason it is well, when such conditions exist, to

place a portion of the weight on the tender, by use of rails chained to the frames, as shown in Fig. 33.

If it is the main driving axle, wheel or tire to which the accident has happened the weight previously carried by this wheel is distributed between the rear wheel and the forward truck so that the increase put upon the former does not double its normal load because it is farther removed from the center of gravity of the engine than the point of suspension of the equalizer.

*Q. Does a driving wheel tire ever leave the center except by breaking?*

A. Yes; they frequently become loose and may leave the centers on that account.

*Q. What causes driving wheel tires to become loose and how can that looseness be detected before any damage is done?*

A. A driving wheel tire may become loose by being worn so thin that the action of the rails hammers out the metal and stretches it until its elasticity fails to hold it to the center. This is sometimes facilitated by the fact that the tire was put on too tightly in the first place. Such a condition may put the metal under such a stress, after it has been worn thin, that the limit of elasticity is exceeded, and the tire takes a permanent set, when the elongation due to the action of the rails will make it loose. Or it may have been put on with not enough shrinkage, so that the service to which it is subjected soon loosens it.

One of the first indications of a loose tire will be the oil that will seem to be oozing out between the tire and the

center. To test the matter a chisel mark may be made on the tire and the center and the engine then started two or three times. If the two marks show any shifting it is a sure sign of looseness. The fact, however, that they do not shift cannot be taken as positive evidence that the tire is tight.

An engine upon which it is suspected that a tire is loose should be run slowly and cautiously to the terminal.

*Q. What should be done when a driving box brass breaks?*

*A. The wheel to which the box holding the brass be-*

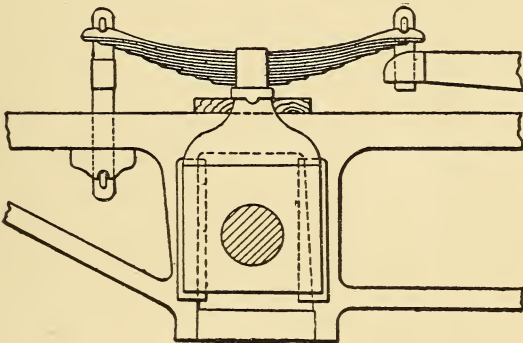

FIG. 35.—BLOCKING BENEATH SPRING STIRRUP TO RELIEVE  
BROKEN DRIVING BOX BRASS.

longs may be run up on a wedge. This will lift the spring saddle and a block can then be driven in between the top of the frame and the spring saddle, as shown in Fig. 35, which will allow the equalizer and springs to act and relieve the box of the weight that would otherwise be put upon it.

If the springs are hung beneath the driving boxes the work will be more difficult. The exact method to be fol-

lowed will depend upon the type of suspension. Should the springs be carried by hangers supported on top of the box it may be possible to jack up the spring, remove the hangers and chain the spring or pedestal to the bottom rail of the frame or to the pedestal legs.

In case the spring is carried by a hanger made solid with the bottom of the box, it may be found best to remove the spring or chain the end of the equalizer or equalizers next the broken brass to the lower rail of the frame, as in Fig. 32.

If it is the rear brass of an eight-wheeled engine that is broken, it will be well to carry a portion of the weight of the rear end on the tender frame, as described in the answer to the question on page 78, and shown in Fig. 33, provided there is room to get the pieces alongside the frames.

*Q. What should be done if a driving box breaks?*

A. This accident very rarely occurs to such an extent as to render the box useless. The lugs at the sides are frequently broken but this does not so impair the strength of the box that it becomes necessary to relieve it of the weight which it is carrying. When, however, such an accident does occur the emergency should be treated in the same manner as the broken brass described in answer to the preceding question.

*Q. If the main box of a ten-wheeled (4-6-0) engine is broken so that the brass is useless, how should the blocking be done?*

A. The same method should be used as in the case of a broken main driving spring, except in the fixing of the main box, the blocking should be put beneath instead of above it,

and a notched block should be above the axle to steady it and assist in taking the thrust of the connecting rod while the engine is in motion.

*Q. What is the cause of the pounding of the driving boxes in the wedges when the engine is in motion?*

A. A looseness in the fit between the box and the wedges due to wear or improper fitting when the engine was erected.

*Q. Why is the pounding of the driving boxes usually worse upon the left than upon the right-hand side of the engine when running forward and worse upon the right-hand side when running backward?*

A. This is due to the relative position of the cranks. The cranks are set on the quarters with the right-hand one usually leading when the engine is running ahead. Following the course of the steam distribution for a revolution will make the action clear. When the right-hand crank passes the back center its cylinder takes steam at the back end and the driving box is pressed against the forward wedge. This continues until the top quarter is reached when the same thing takes place on the left-hand side. Soon after the exhaust is opened on the right-hand side and there is no further pressure in the cylinder to hold the box against the front leg of the pedestal, and the box is free to swing back. This it does under the influence of the steam pressure in the left-hand cylinder. This pressure tends to draw the left crank pin ahead, and so the axle turning on the left-hand box as a fulcrum is thrown back on the right-hand side and that box is moved against the rear pedestal with a comparatively light pound, owing to the distance between the boxes being

so much greater than that from the left-hand box to the crank pin.

This puts the right-hand box in a position to take the thrust of the steam when the crank passes the forward center and no pound takes place at that time.

The exhaust then opens on the left-hand side with the box against the forward wedge where it is held by the steam pressure upon the right-hand side, tending to thrust that end of the axle to the rear, while the left end is held to the front with the box. This continues until the left crank passes its forward center, when the admission of steam to the front end of its cylinder thrusts it, and with it its box, violently to the rear and there is a heavy pound as the latter strikes the wedge.

It will thus be seen that when steam is admitted to the right-hand cylinder the box is always against the proper wedge to withstand the thrust, while, in the case of the left-hand box, the opposite condition exists.

These conditions are reversed when the engine is running backward and the left is the leading crank.

*Q. How can the pounding of driving boxes be remedied?*

A. By setting up the live wedges, and this can be done as follows:

In order to do this properly all of the boxes must be brought up snugly against the front wedges, which are usually the fixed or dead ones. This may be done when the engine is cold by pinching it ahead until the cranks are upon the upper eights. This pushes all of the boxes against the front wedges. If the cranks are on the lower eights the

boxes will be drawn against the rear wedges when the pinching is done against the rear wheel.

The boxes may also be drawn against the forward wedges by moving the engine into the upper eighths position and then, after blocking the wheels, admitting a little steam to the cylinder.

When the boxes have been properly set, the live wedges should be run up against the boxes with a short handled wrench so that they may not be set up too tightly.

As there must be some play between the wedges and the box, they will probably bind if left in this position. It is, therefore, necessary to relieve them a little. To do this make a mark on the pedestal at the tops of the live wedges and then lower each to them an equal amount, which should be about  $\frac{1}{8}$  inch. This will make it possible for the boxes to play freely up and down between the wedges and yet not be so loose as to pound.

*Q. If a wedge bolt breaks, what is apt to be the result?*

A. The upward movement of the box is liable to catch the wedge and carry it up with it until it is jammed and stuck.

*Q. What should be done with a broken wedge bolt?*

A. It is sometimes possible to splice the two ends of the bolt together by screwing each of them half way into a nut. When this cannot be done the wedge may be held up in position by a nut or piece of iron fastened beneath it with a piece of wire.

*Q. What will be likely to occur in case the box is stuck between the wedges?*

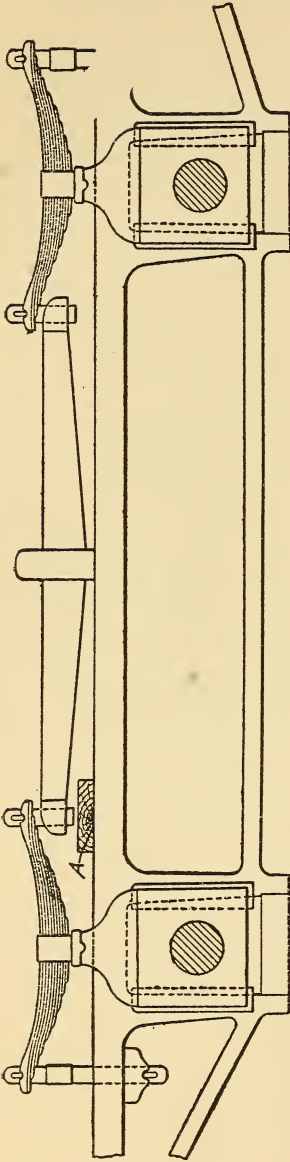

FIG. 36.—STRIKING PIECE FOR EQUALIZER WITH A CRACKED SPRING PLATE.

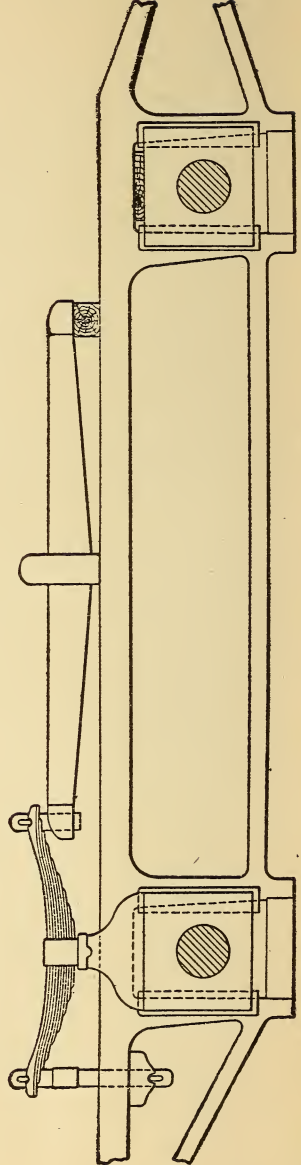

FIG. 37.—METHOD OF BLOCKING FRAME WITH BROKEN MAIN DRIVING SPRING OR HANGER.



A. The first effect of the fastening of the box will be to cause the engine to ride very hard by depriving it of the action of the springs. When the box clears and lets go the sudden release of the frame will throw such an excessive stress upon the springs that they or their hangers may be broken.

*Q. How may a driving spring with a cracked leaf be protected against breaking?*

A. Where a driving spring has been weakened by the cracking of a plate, and is still strong enough to carry its load under ordinary conditions, it may be protected against further fracture by partially blocking the equalizer. This can be done by strapping a nut or block to the frame or equalizer, as shown in Fig. 36. The stop piece *A* should be fastened on top of the frame in such a way that it does not touch the equalizer under ordinary conditions. Then, if an excessive jar causes an undue deflection of the spring, the end of the equalizer striking this block will relieve the spring of the extra stress to which it would otherwise be subjected, and thus avoid a further break.

*Q. What should be done if a driving spring stirrup or hanger should break?*

A. The work to be done is to relieve the broken part of the load and so block the frame that the engine can be run. In order to do this blocking it is necessary that the frame should first be raised from the driving box over which the break has occurred. This may be done either by jacking or by running the wheels up on wedges laid on the rails. The former requires a longer time and so can hardly be used

where a broken engine is blocking the main line. Where the wheels are run up on wedges it must be done carefully as there is always a danger of derailment.

If it is the main spring stirrup or hanger that is broken, on an eight-wheeled (4-4-0) engine, a block should be put over the rear box and beneath the frame or wedged in between the equalizer and the frame. The rear wheel is then to be run up on the wedge, thus lifting the frame and relieving the front or main box of its load. Blocking should then be placed between the main driving box and the frame and the rear wheel run down from the wedge. This relieves the equalizer of its load and the main spring, with its stirrup and hangers, can then be removed and blocking put between the equalizer and the frame, thus raising that bar up to its proper position with the final blocking in position, as shown in Fig. 37.

In case of underhung springs the method of procedure is the same with the exception that it may be difficult to block or chain the equalizer. Under these circumstances it may be necessary to place blocking over both boxes and remove all of the spring rigging from that side of the engine.

If it is a stirrup or hanger of the rear or trailing axle spring that is broken the process must be reversed. That is to say the front wheel should first be run up on the wedge to relieve the rear boxes of the weight and thus make it possible to block over that box.

When the accident occurs on the main spring stirrup or hanger of a mogul (2-6-0) or ten-wheeled (4-6-0) engine the weight can be removed from the box by running the

front wheel upon a wedge. If it is at the front or rear spring, the main wheel should be raised.

The blocking of the rear and main driver of the mogul should be done in the same way as that described for the eight-wheeled engine. If it is at the forward box, it may be necessary to remove the springs from both sides as these are equalized with the truck. Should it be the hanger only that is broken, the fractured part may be replaced with a chain.

If it is found to be necessary to block both of the forward boxes, the intermediate equalizer to the truck must also be blocked, as in Fig. 46.

The chief thing to be borne in mind is, that when the stirrup breaks blocking must be resorted to and that, if the break is on a hanger, it is frequently possible to replace the broken part with a chain.

*Q. What should be done if a driving spring breaks?*

A. This accident involves the same conditions and calls for the same treatment as that detailed in the answer to the question on page 91. It is usually impracticable, or at least undesirable, to attempt to replace a broken driving spring. The better way is to remove all the attachments that are liable to shake loose and proceed to block the engine in exactly the same manner as that prescribed for a broken spring stirrup or hanger.

*Q. If the spring of the main driving box of a ten-wheeled (4-6-0) locomotive breaks how should the blocking be placed?*

A. Where the springs are over the boxes the equalizers

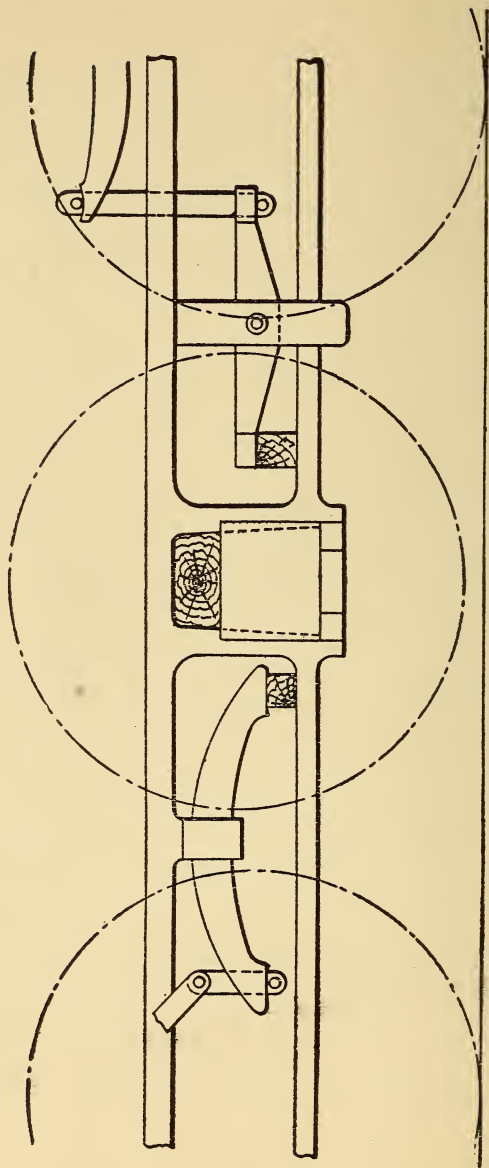

FIG. 38.—BLOCKING FOR BROKEN DRIVING SPRING OF TEN-WHEELED ENGINES.

are usually between the rails of the frame. First put a block in between the top of the main box and the frame and run the driver up on a wedge so as to relieve the front and back wheels of a portion of the weight. Then raise the ends of the equalizers and put blocks in between their inner ends and the lower rail of the frame, as shown in Fig. 38. Then run the main wheel off from the wedge and the forward driver up on it. This will relieve the main box of the load and make it possible to put in a thicker block so as to raise

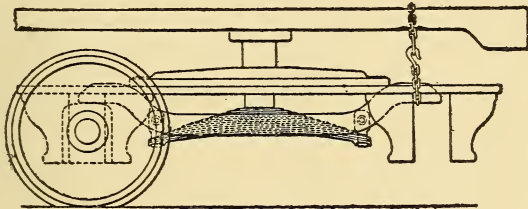

FIG. 39.—METHOD OF CHAINING FOUR-WHEELED TRUCK FRAME WITH A BROKEN FRONT AXLE.

the frame more nearly to its original height. When this has been done the wedge under the forward wheel may be removed and the engine is ready to proceed.

*Q. What should be done if an axle under a front four-wheeled truck breaks?*

*A.* The end of the truck where the break has taken place should be jacked up and the wheels with the broken axle, the boxes and other parts likely to shake loose removed. The end of the truck so raised should then be chained securely to the frames, as shown in Fig. 39, after which the engine may be slowly run to the terminal.

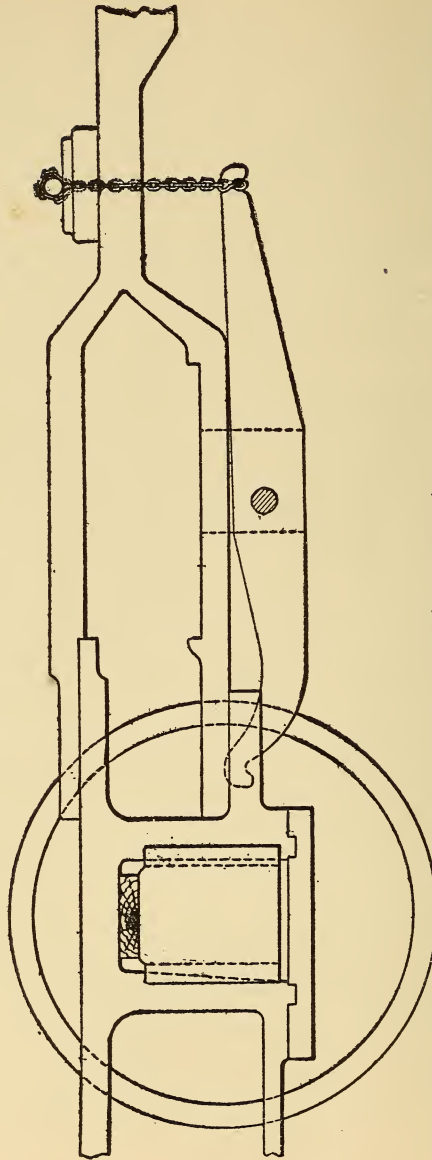

FIG. 40.—METHOD OF CHAINING TRUCK EQUALIZER ON MOGUL AND CONSOLIDATION  
LOCOMOTIVES WITH BROKEN TRUCK OR TRUCK AXLE.

*Q. What should be done if the truck axle of a consolidation or mogul engine breaks?*

A. The front end of the engine should be jacked up and the truck removed. This is facilitated by taking down the pilot or front step. While the front end is thus raised, the forward spring stirrups should be removed and blocking placed beneath the frames on top of the oil boxes, as shown in Fig. 40. This will keep the front end of the engine up and at the same time put the load previously divided between the truck and the front driving wheel entirely on the latter. It may also be found to be necessary to remove the springs to prevent them from shaking loose.

After the engine has been thus blocked it may be run slowly and carefully to the terminal, keeping it in mind that the forward axle is carrying an excessive load and is liable to heat.

*Q. What precaution should be taken in the inspection of the running gear to avoid accidents upon the road?*

A. The springs, spring hangers and equalizers should be carefully examined for incipient cracks and flaws, and the tires, for any indication of looseness. As soon as any such defects appear they should be remedied at once, as the running stress will be very apt to increase them and make them dangerous. In the matter of axles, the breakage usually occurs next to the wheel on the inside, where it is impossible to inspect. Safety here lies in using ample strength at the start and limiting the life of the axle to what it is known it will stand.

## CHAPTER VI.

### Truck and Frame Accidents.

*Q. How can the truck of a mogul or consolidation engine be removed?*

A. First disconnect the radius bar and then block up the front end of the engine to a height sufficient to permit the removal of the center pin from the bearing. The truck can then be removed.

It will depend somewhat on the construction of the engine as to what should be done in the blocking of the equalizer. If this is so proportioned that the rear end will strike the boiler before the front end will come down to the rails it will need no blocking. If this will not occur it may be blocked down at the back, or, better still, chained up at the front by a chain passing through the center pin bearing, as shown in Fig. 40.

*Q. Is it not possible to run the engine with a broken truck axle without removing the same from the frame?*

A. If the axle is broken outside the box, it may be possible to raise that corner of the truck where the break has occurred and by chaining it well up cause the remaining wheel to hug the rail. In this way the engine may be run slowly and carefully without removing the broken axle. This applies only to four-wheeled trucks, as it would be hazardous to attempt to run a pony truck in this condition (see Fig. 39).



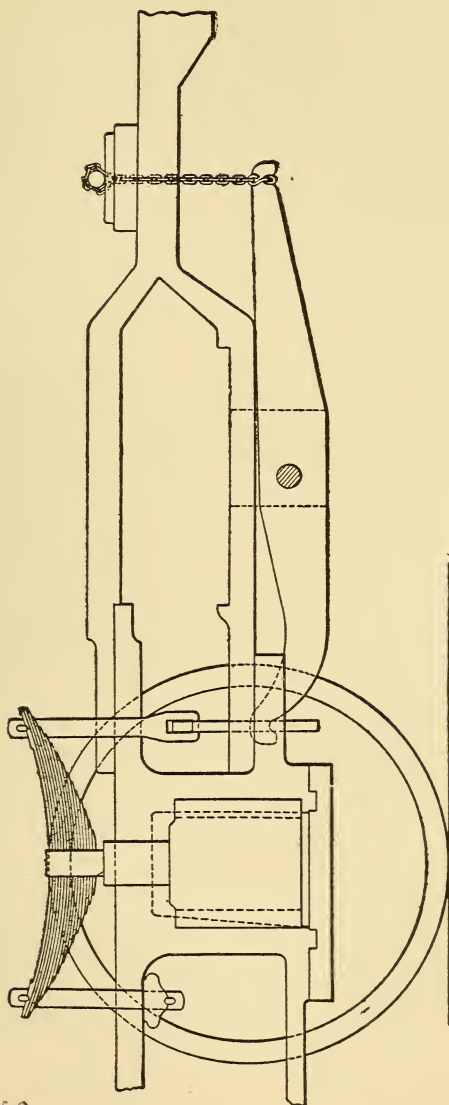

FIG. 41.—METHOD OF CHAINING TRUCK EQUALIZER ON MOGUL OR CONSOLIDATION  
LOCOMOTIVES WITH BROKEN TRUCK OR TRUCK AXLE.

L. of C.

*Q. What should be done when an engine truck frame is broken?*

A. As in many other cases the method to be followed will depend somewhat upon the nature of the break. If the frame of a four-wheeled truck is broken between the bolster and the equalizer springs it may be possible to run it. First jack up the engine to relieve the truck of the weight, and then block up the center of the frame with blocking resting on the equalizers, as shown in Fig. 42. The weight can then

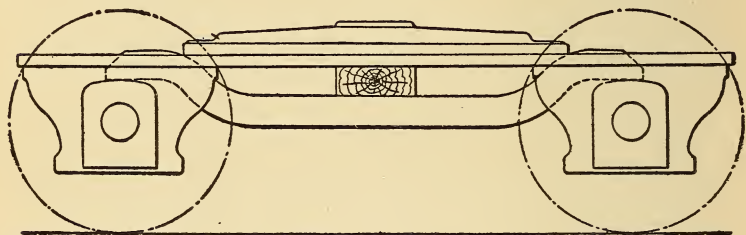

FIG. 42.—OUTLINE OF METHOD OF BLOCKING FOUR-WHEELED TRUCK WITH BROKEN FRAME.

be lowered to rest on the center plate, and the engine run carefully to the terminal.

*Q. What should be done when the pony truck frame under a consolidation or mogul engine breaks?*

A. As this frame corresponds to the transom of a four-wheeled truck frame, it will take less time and be far safer to remove the truck from the engine as described in the answer to the question on page 98, than it will to attempt to splice the frame.

*Q. What can be done in case a spring hanger of an engine truck breaks?*

A. The broken part can usually be replaced by a chain. The bolster or frame should be jacked up above its normal position and the spring chained fast, as shown in Fig. 43. The imposition of the load and the slipping of the chain will usually let it come back to its proper place. The engine should be run slowly and carefully.

*Q. What should be done in case of a breakage of a transom of a four-wheeled engine truck?*

A. It is usually possible to chain the bolster, or, in case

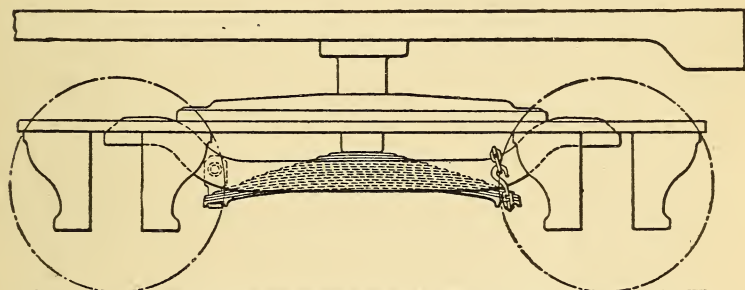

FIG. 43.—METHOD OF CHAINING FOUR-WHEELED TRUCK WITH BROKEN SPRING HANGER.

of a rigid truck, the broken part to a piece of rail laid across the top of the frame. Where a piece of rail of the proper length is not available, the end of the bolster may be chained to the frame, or, with a rigid truck, a heavy stick of timber may be laid across on top of the equalizers to carry the load.

*Q. What should be done with a broken truck wheel?*

A. If it is a rear wheel of a four-wheeled truck, it may be chained to a piece of rail or timber laid across the top of the truck in such a way as to prevent it from turning. The engine may then be moved with the wheels sliding.

If it is a forward wheel that is broken, the same method may be followed to move the engine to a siding to clear the track. After which, if a fresh pair of wheels to replace the broken ones are not available the truck should be taken out and turned around, and then, with the disabled wheels removed, chained to the frame in the same manner as described for a broken axle in the answer to the question on page 95.

*Q. What should be done in case the center pin of a pony truck breaks?*

A. The front end of the engine should be jacked up so as to relieve the equalizer of all load. The back end of this equalizer should then be blocked down, as in Fig. 46, so that the front end cannot strike the axle. After which the jacks can be removed and the engine run cautiously with the full train. The reason for slow and cautious running in this case is that the front truck being entirely relieved of all load would be apt to leave the rails if the speed were high.

*Q. What should be done in case an engine truck center casting breaks?*

A. If the breakage occurs upon a four-wheeled truck it will usually be possible to block it up with pieces of rail or timber placed across the tops of the equalizers.

Should the accident occur on a pony truck the blocking may be put between the top of the truck frame and the engine frame.

In either case, when the engine is so blocked, the truck will not swing readily beneath it, and so there will be a constant danger of derailment on curves. Consequently, the

engine should be run slowly and carefully to the shops or terminal.

*Q. What should be done when an engine truck spring breaks?*

*A.* The front end of the engine should be raised and the truck frame blocked up over the equalizers, as shown in Fig. 44. The blocking should be put over the equalizers because if it is put on the axle boxes, the increased stress put upon

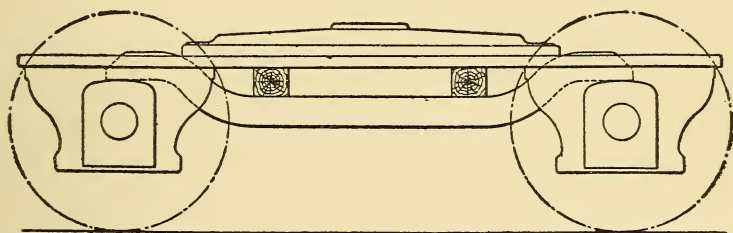

FIG. 44.—METHOD OF BLOCKING ENGINE TRUCK FRAME WITH BROKEN SPRING.

the frame on account of the greater distance of the support from the center may cause the frame to bend.

If, however, the breakage is that of a spring on the pony truck of a mogul or consolidation engine, the truck may be jacked up and blocking inserted between the oil box and the frame.

*Q. What should be done when an equalizer breaks?*

*A.* The engine must first be raised, as in the case of a broken spring stirrup or hanger, page 91. This can usually best be done with a broken equalizer by jacking up the back end of the frame on the side where the break has occurred. All parts likely to shake loose must then be removed, and

blocking placed over both axle boxes next the equalizer to carry the frame, as shown in Fig. 45.

If the break has taken place near the end of the equalizer it may be possible to block under that end in the same way as in Fig. 37, and thus avoid the necessity of blocking over one of the axle boxes.

If the equalizer is below the frame it may be possible to apply the same remedy; chaining the end of the equalizer instead of blocking it, in the same way as in Fig. 32.

*Q. What must be done when an equalizer stand breaks?*

A. If it is the stand itself that is broken the same remedy must be applied as in the case of a broken equalizer (see previous question). Should it be merely the bolts that have given way, it may be possible to jack the engine so as to relieve the stand of its load and then refasten it in position by other bolts.

*Q. What should be done if a cross equalizer on a mogul engine is broken?*

A. Jack up the front end of the engine and put blocking over the forward driving axle boxes to carry the frame. Also remove the springs and the broken part and block the intermediate equalizer down, as shown in Fig. 46. Or, as an alternative, the blocking over the axle box may be omitted and the forward end of the driving spring chained down to the frame, as shown in Fig. 47, provided there is room for the passage of the chain back of the driving wheel. The blocking of the equalizer may be left as described.

*Q. What should be done when the intermediate equalizer of a mogul engine is broken?*

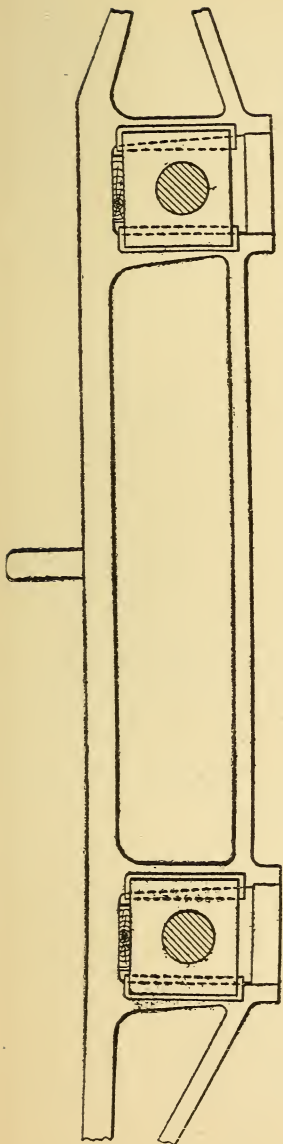

FIG. 45.—METHOD OF BLOCKING A MOGUL OR CONSOLIDATION LOCOMOTIVE WITH A  
BROKEN EQUALIZER.

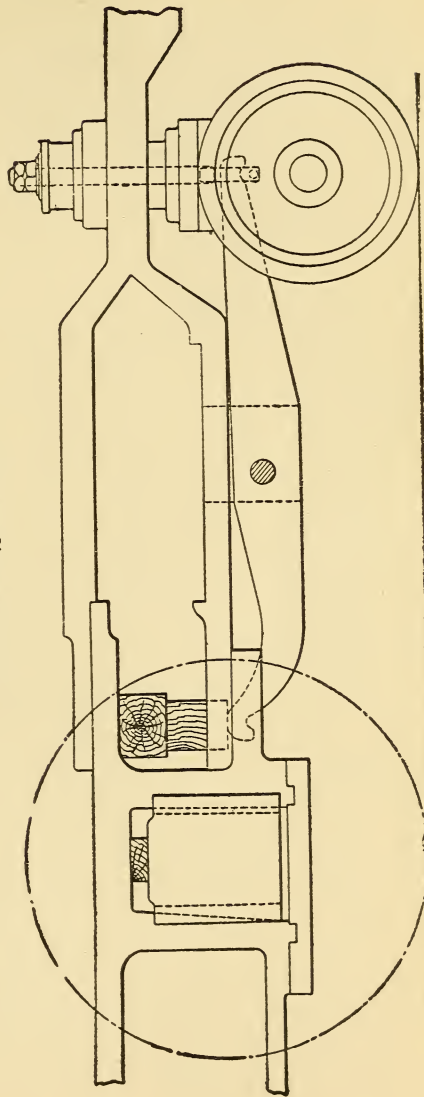

FIG. 46.—METHOD OF BLOCKING A MOGUL OR CONSOLIDATION LOCOMOTIVE WITH A  
BROKEN CROSS EQUALIZER.

A. The front end of the engine should be raised and blocking be placed either over the forward axle box, as shown in Fig. 46, for a broken cross equalizer; or above the cross equalizer and beneath the boiler, thus holding the former down in position. The broken part is, of course, to be removed.

Under the conditions the truck is relieved of its load and

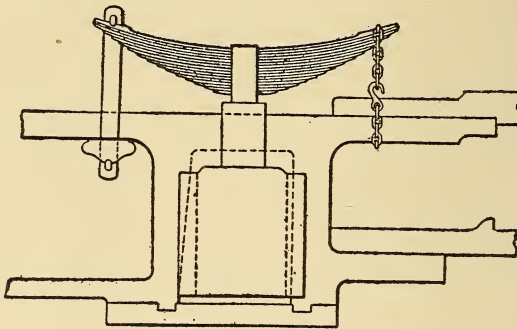

FIG. 47.—AN ALTERNATIVE METHOD OF BLOCKING A MOGUL, OR CONSOLIDATION LOCOMOTIVE WITH A BROKEN CROSS EQUALIZER.

the engine should be run slowly and cautiously for the reasons set forth in the answer on page 102.

*Q. What should be done if an engine frame breaks?*

A. There is really no repairing that can or need be done upon the road. The frame is intended to carry the working parts of the engine and sustain the stresses incident to the work performed. It is, however, supplemented by the boiler and its connections, as well as by its own construction, in that it usually consists of two rails. These are ordinarily sufficient to make it possible to run the engine without dan-



ger of further injury ; provided the speed is low and without making any changes in the parts.

It is well under these conditions to give up at least a portion of the train, and under no circumstances should another engine be allowed to pull one so disabled when there is a train behind the latter.

*Q. If an equalizer is bent or cracked, how can it be protected from further damage?*

A. If the bend or crack is at the center of the bar, the only relief that can be effected will be to remove the bar or chain the ends of the springs to the frames, thus destroying its action, just as when it is broken. If the injury is at a distance from the center, the spring hanger at that end should be removed and the spring chained to the frame, while a blocking may be put between the frame and the bar to prevent motion. This blocking should, of course, be placed between the place where the weakness has developed and the post. This also destroys the action of the equalizer as such, and need only be employed when there is danger of an immediate rupture. It may be added that such defects rarely appear in the body of the rod, but are usually found at the center and ends, where the greater portion of the stresses are carried and the equalizer is weakened by the slots for the posts and hangers.

## CHAPTER VII.

### **Boiler Troubles.**

*Q. What are the principal causes of water being carried over into the cylinders from the boiler?*

A. Priming and foaming.

*Q. What is the difference between foaming and priming?*

A. Foaming is caused by the presence of some foreign substances in the water, such as alkali or oil, whereby a soapy mixture is formed that is very light. There are many other substances besides the two named that may cause this foaming, such as cornmeal, that is sometimes used to stop leaks, and mud.

Priming usually takes place where the boiler is being forced or where the steam space is too small to accommodate the amount being generated. This causes the steam, as it rises from the water, to carry the latter with it and over into the cylinders. This phenomenon may also be caused by defective circulation, whereby the steam does not have room to pass through the water but drives the latter ahead of it as it moves through narrow and contracted spaces.

*Q. How can the foaming of the boiler be detected?*

A. Ordinarily the first indication of foaming is the appearance of water at the top of the stack. When this happens the first thing to be done is to shut off steam and allow the water to settle. If, then, there are three gauges of water, the trouble will probably be found to be due to too much water in the boiler. If, on the other hand, the water

settles down so that there is only one gauge of water, or not even that, foaming will undoubtedly be the trouble. Foaming also manifests itself by the whitish appearance of the steam as it escapes from the stack, cylinder cocks or water gauges, as well as by the sound which it makes when issuing from the latter. It does not make the clear whistling noise of steam nor the rushing noise of water, but a choked flutter.

*Q. When it has been determined that the boiler is foaming what should be done?*

A. The cylinder cocks should be opened so as to prevent the knocking off of the cylinder heads as the result of the entrained water. The surface blow-off, if there is one, should be opened. The left injector, as well as the right, should be put to work to raise the water level. Steam should be shut off at frequent intervals, and the water allowed to settle, so that its true level may be known and not allowed to rise too high or fall too low, and the speed should be reduced if necessary.

On reaching the first stop, enough solid water should be in the boiler to permit it to be blown down for two gauges.

*Q. What should be done when a boiler is priming?*

A. The injector should be shut off and the water level lowered and the fire checked so as to lessen the rate of evaporation.

*Q. How can the foaming of oily water be checked or stopped?*

A. A piece of sulphate of copper or blue vitriol placed in the supply pipe will frequently stop foaming due to oil or grease, provided no alkali has previously been put in the

water. The blue vitriol can be obtained at any local telegraph office.

As soon, however, as a water station is reached, the tank should be allowed to overflow freely, so that the oil which rises to the top of the water may be swept away. This method of getting rid of the oil is further facilitated by putting on the heater at the same time.

*Q. If the water in a boiler falls so low as to leave the crown sheet uncovered, what should be done?*

A. The engine should be stopped and the fire banked with earth so as to prevent the crown sheet from being burned. After the boiler has cooled somewhat and the steam pressure has fallen, the injector may be started and the water level raised. When water appears at the first gauge, the fire may be cleaned and the run resumed.

*Q. If the boiler is fitted with a fusible plug that is melted on account of the water falling to too low a level, what should be done?*

A. This will put out the fire and disable the engine. It only remains to protect the train and prepare to be towed in.

If, however, another fusible or solid plug is available, this may be put in place after the steam pressure has been lowered, and the boiler again filled through the safety valve, after which the fire may be rekindled. As this involves the consumption of an excessive length of time, it is usually out of the question to consider it.

*Q. What should be done if a flue is leaking badly?*

A. If the leak is at the tube sheet where the tube is expanded into place, nothing can be done upon the road. If,

however, the leak is due to a defective tube, and water is blowing through to the firebox, it may be plugged. This can be done by cutting the end of a pole into the shape of a plug that will fit the interior of the tube, and practically cutting it off so that the pole can be easily broken at that point, as shown in Fig. 48. This plug is then inserted in the end of the tube and driven home, after which the pole is broken, at the partially severed point, leaving the plug in position as shown in Fig. 49. The part of the plug projecting into the firebox will be burned off, but the body, being



FIG. 48.—POLE SHARPENED FOR PLUGGING TUBE AND READY FOR INSERTION.

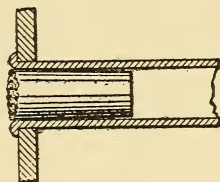

FIG. 49.—A PLUGGED TUBE.

protected by the tube, will usually hold in position until the end of the run is reached. This causes the leaking steam and water to go into the smokebox, whence it is carried away by the exhaust.

There are plugs especially made for doing this work, but they are not ordinarily supplied to locomotives. An example of this type of plug is shown in Fig. 50. This is known as the Morgan tube stopper and can only be applied when the engine is cool. It consists of a cap that sets down over the end of the tube, and is held in position by a bolt running through to a similar cap at the other end of the

tube. These stoppers are extensively used at sea, but their application to locomotive work is quite limited.

*Q.* If, in blowing down the boiler in accordance with the answer to the question on page 109, the blow-off cock should become clogged so that it cannot be closed, what should be done?

*A.* Such a condition will probably result in the empty-

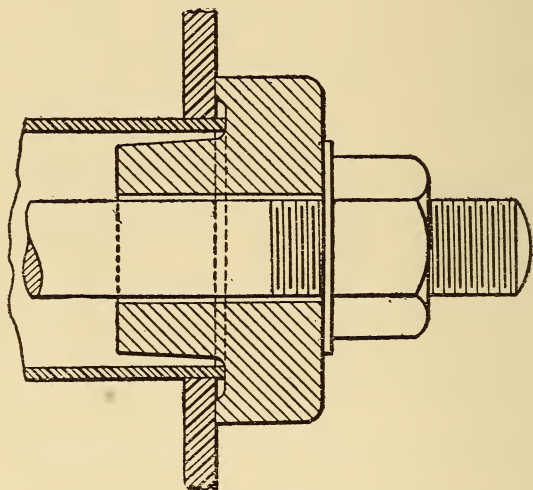

FIG. 50.—THE MORGAN TUBE STOPPER.

ing of the boiler to such an extent as to lay bare the crown-sheet of the firebox to the action of the fire. The fire should, therefore, be drawn at once. If the bed of coals happens to be thin at the time, it may be possible to draw it away from the firebox sheets and heap it up on the center of the grates and then deaden the whole by shoveling in damp earth, thus choking the fire and keeping the incandescent coal away from the sheets, so as to avoid all possibility of burning.

*Q. In case the drop grate on a locomotive having a shallow ash pan should become broken or burned out, what should be done?*

A. The fire should be drawn back off from the broken part and the space beneath filled up to the level with the top of the grates with stones. The coal should be thrown on over it, that an excessive amount of air may not be drawn up through the air space between the stones.

*Q. If the drop grate on an engine having a deep hopper ash pan should be broken or burned, what should be done?*

A. The engine should be run to the first point where a supply of splice bars or other short lengths of iron or steel can be obtained, and after pulling back the fire, these may be used to bridge the opening and form a grate to carry the fire to destination.

*Q. How can leaky joints in the exhaust pipe of a locomotive be located?*

A. This is not a serious defect, nor is it one that will require any attention upon the road. Where the air brake pump exhausts into the passages of the saddle, a leak may be located by plugging or blocking the nozzle and starting the pump with an angle cock open so that no pressure will accumulate in the main reservoir. The pressure of the exhaust, that will be choked by the plug in the nozzle, will cause the steam to escape from any leaks that may exist in the passages or pipes.

If the air pump does not exhaust into these passages, it will be exceedingly difficult to make a proper examination. It may, however, be done when the steam is low, with a pressure of from 25 to 30 pounds.

The nozzle should be plugged as before, and the wheels thoroughly well blocked. The throttle may then be opened a little and the reverse lever moved backward and forward. This will put a pressure in the exhaust pipes and passages that will escape from the leaks if there are any.

*Q. What is the best time to inspect an engine for leaky steam pipes in the front end?*

A. It is well to do this after the fire has been drawn and the boiler allowed to cool, so that the temperature of the front end has fallen considerably below that existing there when the engine is at work or just in from a run. This will make it possible to see where the leaks are much more easily than when everything is hot, since, under the latter conditions, the escaping steam is taken up by the hot air and cannot be seen as readily as when the boiler is cooler, neither is it possible for the inspector to examine the suspected parts as closely.

*Q. Is there any danger in allowing boilers to stand under pressure?*

A. The evidence on this point is not altogether conclusive, as it has not yet been positively ascertained exactly what occurs inside of a boiler when an explosion does take place after the boiler has been standing under pressure for a time. The following phenomena have, however, been observed:

Water that has been in a boiler until the air has been expelled and then allowed to cool and become quiet, can be heated in the open air to a temperature considerably above the boiling point before ebullition will take place. Water



so superheated will burst at once into a violent state of ebullition that amounts almost to an explosive energy, if the vessel containing it is subjected to jars or shocks. It is a common occurrence for boilers to explode at the instant of the opening of the throttle after they have been standing for a time.

The conclusion that has been drawn from this series of observed phenomena is that, the boiler having been quietly standing under pressure, the water has become superheated, and then, when the throttle is opened, the outflow of steam causes a disturbance of the water resulting in a sudden liberation of steam with a correspondingly sudden increase of pressure. This increase of pressure, though comparatively slight, but acting, as it does, like a blow upon the sheets, may be sufficient to cause a weak section to give way, thus producing an explosion that would not have occurred had the boiler been in first class condition.

*Q. Does the form of the seams of a boiler have any effect upon the rate of deterioration of the sheets?*

A. Yes, a very decided effect. A seam should be so constructed that the application or removal of pressure from a boiler should have no effect upon the shape of the metal of which the seam is formed. That is to say, the variation of the pressure should have no tendency to cause a bending of the metal. Thus the old fashioned lap seam, Fig. 51, is of such a character that, when pressure is applied to the boiler, there is a tendency to bend the sheet at *a*. A continued repetition of the load frequently causes grooving and subsequent fracture at that point.

On the other hand, with the welt seams, Fig. 52, there is no such tendency to bend the metal.

*Q. Is there any danger in making repairs while pressure is upon the boiler?*

*A.* It is inadvisable to do this because, if the metal is

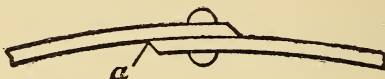

FIG. 51.—LAP SEAM.

grooved or weakened in any way, the jar due to the use of a hammer or calking tool may start a crack that will precipitate an explosion. It is a safe rule to follow that all repairs should be made on a cold boiler.

*Q. What should be done if a sheet cracks?*

*A.* Cracked sheets are not uncommon in locomotive boilers. The places where such cracks most commonly ap-

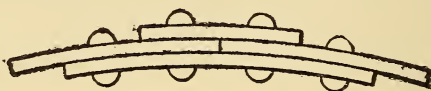

FIG. 52.—A WELT SEAM.

pear are the throat sheet, the tube sheet and the side sheets of the firebox. The cracking of a sheet does not necessarily mean that an explosion is imminent. On the other hand, the very fact that the crack was not followed instantly by an explosion is a warrant that it is not threatened immediately. However, the crack does indicate a weakness of the boiler, and the pressure should be at once reduced.

This can best be done by throwing earth in on the fire and starting the injector. A careful inspection should be made to determine the extent of the injury, and the continued movement of the engine or train should depend upon the extent of damage sustained and the likelihood of an increase of the same.

*Q. What should be done in the case of a blistered sheet?*

A. Blistered sheets are not as common in steel as they were in iron on account of the greater homogeneity of the former metal.

Blisters occur in the firebox where the plates are subjected to the direct action of the fire. They are of the same shape as a blister upon the hand and are of all sizes from that of a five cent piece up to a foot or more across. They have the same shape, but should not be confused with bagging or sagging. When a blister forms the same precautions should be taken as in the case of a cracked sheet. If inspection shows that the blister is not large and has not raised away from the sheet over an area measuring more than two or three inches across, the engine may proceed under reduced pressure, but repairs should be made before it is again sent out upon the road.

*Q. What is the progressive action of a steam boiler explosion?*

A. The initial rupture takes place at some point of weakness of the structure, which opens sufficiently to permit of the outpouring of a considerable quantity of the contained steam and water. These contents rush out with a tremendous velocity under the influence of the pressure existing

within. The impact of this rapidly moving mass against the surfaces and edges of the already weakened part produces stresses far in excess of those existing before the initial rupture took place. The result is that, in an inconceivably short space of time, the sheets are torn asunder, and the reaction of the expanding steam on the unsupported plates of the boiler hurls the latter from its setting, spreading death and destruction, and the explosion is an accomplished fact.

The rupture usually follows lines of weakness previously existing in the sheets either as the result of deterioration or of construction. Thus it will follow groovings along a lap, the line of rivet holes of a seam, or the edge of a welt where there is a chance for the sheet to make a short bend and tear like paper along the edge of a ruler.

*Q. What is the source of the energy set free in boiler explosions and what is its magnitude?*

A. The source of the energy displayed in boiler explosions is the heat stored in the contained water. Other things being equal, the greater the quantity of water held by the boiler the greater will be the effects of the explosion. The water is heated to a temperature corresponding to the pressure of the steam. Thus, if the pressure is 180 pounds per square inch, the temperature of the steam and water will be 380 degrees Fahr., or 168 degrees more than the temperature of water boiling in the open air. To convert water of 212 degrees Fahr. into steam having the tension of the atmosphere requires an addition of about 965.0 heat units. Hence, if a pound of water at a temperature of 380 degrees be cooled

to 212, 168 heat units will be set free, or enough to evaporate 17 per cent. of the water into steam having the tension of the atmosphere.

This is exactly what takes place in a boiler explosion. The restraint upon the expansiveness of the steam having been removed, a portion of the water flashes into steam and this, expanding to atmospheric pressure, causes the parts of the fractured boiler and adjacent objects to be hurled in all directions.

Considering the subject from another point of view, namely, the amount of energy set free by the explosion of a locomotive boiler. Take a boiler containing 2,400 gallons, or 20,000 pounds of water, at a temperature corresponding to a pressure of 180 pounds per square inch. In cooling down to 212 degrees, each pound liberates 168 heat units or a total of 3,360,000. As the mechanical equivalent of a heat unit is 778 foot pounds, the mechanical energy of the heat thus set free is 2,614,080,000 foot pounds or an amount sufficient to lift a locomotive weighing 190,000 pounds to a height of more than two and a half miles. Of course no such results as this are ever developed because of the dissipation of the energy in all directions. But the energy thus shown to exist gives an idea of the reason why boiler explosions are so disastrous.

*Q. Is the fact that a boiler has been tested at hydrostatic pressure an absolute safeguard that a boiler will not explode when subjected to the same steam pressure?*

A. No. There are numerous instances on record where a boiler has been subjected to a hydrostatic test and, almost

immediately afterwards, when under steam of less pressure, has broken a brace or exploded.

The reason for this is that, in the two cases, the conditions of the stress are very different, and this is due almost entirely to differences of temperature. In the case of the hydrostatic pressure, the water is cold or, at any rate, considerably below the boiling point, whereas when the boiler is under steam the whole structure is heated to a high temperature and there may be wide variations in the temperature of the different parts, thus introducing stresses that are entirely independent of the pressure.

*Q. What are some of the causes of locomotive boiler explosions?*

A. In comparison with boilers used in some other classes of work, locomotive boiler explosions are infrequent, and are usually due to the deterioration of age and service or to negligence on the part of the engineer. There are almost no locomotive boiler explosions occasioned by bad design. They are now built in accordance with approved designs, and there is rarely a defect in one of these boilers that is not common to the whole class.

Explosions due to deterioration may result from a thinning of the plates by corrosion, the cracking of the same by repeated bendings under the influence of unequal expansion and contraction of the different parts and the breaking of the staybolts in the firebox in such quantities that the sheets cannot withstand the pressure, and they give way.

Neglect may result in an explosion and low water may be the cause. If the crown-sheet is allowed to become bare

while a high steam pressure is still maintained, the sheet will be overheated and weakened. If this is carried far enough, as it sometimes is, the sheet will first bulge downward, bagging between the staybolts and stretching the metal, as shown in Fig. 53. When this has reached a certain limit, the plate will be stripped from the staybolts and the crown-sheet will come down.

In a general way the statement holds that locomotive

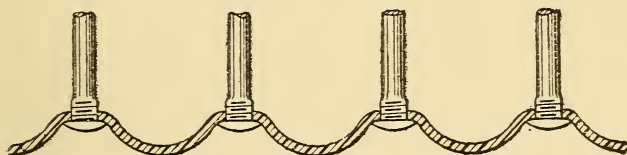

FIG. 53.—A BAGGED CROWNSHEET.

boiler explosions invariably occur because the boiler itself is too weak to withstand the pressure to which it is subjected.

*Q. Where are staybolts most apt to break?*

*A.* In the upper rows at the front end of the firebox. It is at this point that the widest variations of expansion of the two plates united by them take place. The side sheets are rigidly fastened together at the mud-ring, and also at the back head. As the inside sheet is subjected to the direct action of the fire, it is the hotter of the two, and therefore expands the more. The difference in the expansion of the two plates is subject to constant variation, and this causes a continual bending of the staybolts at the inner face of the outside sheet, a bending that will eventually cause fracture.

*Q. How are broken staybolts detected?*

*A.* By striking on the outer end with a light hammer and

listening to the sound. If the noise of the blow is like that struck upon a solid substance, the probability is that the staybolt is intact. If a hollow sound is given out, the staybolt will undoubtedly be found to be cracked. No written or verbal instructions, however, will serve to make a man a staybolt inspector. It can be learned only by practice and close observation.

*Q. What are some of the common causes of boiler depreciations that are apt to cause explosions?*

A. The most common is a corrosive grooving that is apt to take place along the edge of a longitudinal seam due to a constant bending at that point, which is usually due to an improperly made seam, or one wherein the plate has been grooved by the calking tool. Pitting may also be the cause of an explosion, though this is more rare as it is easily detected by inspection, and the sheet removed before a dangerous condition has been reached. The same holds true of the external corrosion of the firebox sheets. The repeated rolling of the tubes may also bring about a dangerous condition, on account of the metal being made so thin that it will not remain tight. This, however, rarely causes an explosion, as the tubes will give ample warning of their condition by leaking, so that they must be removed before the pressure becomes such as to strip them from the tubesheet.

To sum this matter up, locomotive boiler explosions are due to a deterioration of the sheets of the shell or firebox or to the negligence of the engineer.

*Q. What is the progress of events in the overheating of a crownsheet?*



A. It is well known that both iron and steel lose in tensile strength very rapidly as they are heated. At a temperature at which they are a bright red, they have only about one-fourth the tensile strength that they have at the ordinary steam temperatures. While at a welding heat they have no resisting properties and cannot sustain any load.

Consequently, when the crown sheet becomes bare, while subjected to the action of the fire, it is rapidly heated and weakened. Then, yielding under the pressure of the steam in the boiler, it first bulges, as shown in Fig. 53, the metal stretching in the operation until at length the sheet is stripped from the staybolts, comes down, and an explosion is the end.

*Q. What is the cause of the grooving of boiler plates and how does it progress?*

A. As already stated in the answer on page 115, grooving is apt to occur in the face of a sheet at the edge of the lap of the seam, especially if it is a plain lap seam as shown in Fig. 51. The metal, being bent to and fro at this point, breaks the scale and first exposes the clean metal to the corrosive action of the water. Continued bending strains the metal so that a slight crack starts; and corrosion, taking place along the side of this crack, produces a groove.

*Q. What is the cause of bulging sheets in the firebox?*

A. This may be due to the same cause as that already noted in the answer on page 121 regarding the collapsing of a crown sheet. When sheets are covered with oil or scale, they may be overheated to such an extent that they will yield before the pressure to which they are subjected, and thus

bulge inwards. Another cause, resulting in their overheating, is the forcing of the fire.

It has been pretty accurately ascertained that when the water leg is narrow and the fire forced, there may not be any water in contact with the side sheets of the firebox at all, but in its stead a stratum of steam as much as  $\frac{3}{4}$ -inch thick. As steam is not so good a conductor as water, it allows the sheet to be overheated and bulging may take place.

*Q. What should be done if a sheet bulges?*

A. The intensity of the fire should be checked at once, and the engine worked under a reduced pressure to the terminal, where the sheet should be replaced.

*Q. What should be done in case a handhole plate or plug is blown out?*

A. The fire should be drawn or deadened at once, as this accident will result in the emptying of the boiler.

The remedy that can be applied will depend to a great extent upon what has happened. In the case of a handhole plate blowing off, it is usually due to the breakage of a bolt. If the plate can be found, it may be replaced by using another bolt, or a piece of sound wood may be used as a substitute for the plate.

In the case of a plug blowing out, one of soft pine may be driven in in its place.

After the hole has been closed, the boiler may be refilled, a fire built, and steam raised to a low pressure, with which the engine may be run to its destination.

*Q. If a boiler has become emptied while upon the road,*

*for any reason, as in the case of the preceding question, how can it be refilled?*

A. This is a slow and laborious process where the engine is off alone by itself. It can only be done by means of pails and pouring the water in through one of the openings that may be obtained by unscrewing the whistle, a safety valve or other part giving free access to the boiler.

*Q. How can boiler deterioration due to the accumulation of scale be prevented?*

A. Naturally the best way will be to avoid the accumulation of scale, which can be easily and cheaply effected by purifying the water and removing all of the scale-producing compounds from the water before it is put into the tender.

Where the apparatus is not available for effecting this purification, it must be borne in mind that all of the scale-producing contents of the water are carried forward to and deposited in the boiler. The evils of this deposition may be relieved by the use of certain chemicals placed in the tank every time that it is filled. What these should be and the quantity that should be used will depend entirely upon the chemical composition of the water and nothing will be found to be a universal remedy for all waters, and no one should be used indiscriminately. Such a compound merely so affects the water that the scale formed is not hard and does not cling to the surfaces of the tubes and sheets, but can be readily washed away. In any case where untreated scale-forming waters are used in a boiler, frequent washing, preferably with hot water, should be resorted to.

## CHAPTER VIII.

### **Defective Throttle and Steam Connections.**

*Q. What should be done in case the throttle valve becomes disconnected?*

A. This accident most frequently occurs in consequence of the connecting pins at the valve working out. It may happen with the valve open or closed.

If the valve is closed, the engine is helpless; the fire should be deadened and the engine disconnected so as to be towed in. The only way in which the difficulty can be remedied is to reduce the steam pressure to nothing, remove the dome cap and replace the lost connection pins.

If the accident occurs when the throttle is open, steam should be immediately reduced so that the reverse lever can be easily moved to and fro. This will enable the engineer to control the movements of the machine. If the train is fitted with air brakes they should be used cautiously, and if only hand brakes are available the train crew should be notified of the condition of affairs and instructed to stand by ready to apply them when they are called for.

Meantime notice of the accident should be sent to headquarters.

*Q. What should be done if a dry pipe collapses?*

A. This is practically the same accident so far as the effect upon the engine and the method of dealing with it is concerned as that of a disconnected open throttle valve (see the preceding question).

*Q. What should be done when the throttle valve leaks?*

A. This may be the result of wear or the cutting of the valve or seat on account of wire drawing. It is more annoying than dangerous and the only precaution that need be taken will be to always have the cylinder cocks open and the reverse lever in the central notch when the engine is standing.

*Q. How is it possible to tell whether it is the dry pipe or the throttle valve that is leaking?*

A. As the throttle valve is located well up above the water level, the steam leaking through it will be dry; whereas the dry pipe, being close down to the water and sometimes actually submerged in it, will leak more or less water.

*Q. What should be done in case a whistle or safety valve is broken off or blown out?*

A. As the hole is small, it can usually be plugged as soon as the steam pressure has blown down sufficiently to permit the work to be done. The plug had best be of hard wood cut to fit and then driven home, after which it should be tied down with a bell cord or braced in position.

As the blowing off of the steam through the hole opened by the fracture will lower the water rapidly, both injectors should be started and run as long as possible, and the fire deadened until the plug is in position. It will probably be unnecessary to kill the fire.

*Q. What should be done if a steam pipe bursts or is broken?*

A. This is an accident of the same nature as the breaking of a steam chest or cover, and calls for the same general

treatment. The only way in which the flow of steam can be stopped is to remove the broken pipe and bolt a plate over the T head connection of the same, using paper felting or wood to pack it as shown in Fig. 54. It may be possible to stop this flow for a short time by driving a plug into the tee and bracing it there so that it cannot be blown out. This cannot be depended upon, however, for any length of time, as the heat of the firebox is apt to shrink the wood and make it loose.

After the opening has been stopped, the valve on the disabled side should be disconnected and clamped

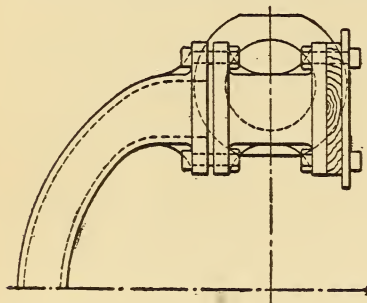

FIG. 54.—PLATE BOLTED OVER TEE HEAD FOR BROKEN STEAM PIPE.

and clamped (page 18), the main rod taken down, and the cross-head blocked (page 20).

*Q. What should be done if the steam pipes are leaking?*

*A.* This may have a very detrimental effect upon the steaming qualities of the engine, but it is best to make no attempt to remedy the difficulty upon the road. At the end of the run the leak should be stopped by the application of a new pipe or the repairing of the old one.

*Q. How can leaky steam pipes be detected?*

*A.* The blowing of the steam can usually be heard when the firedoor is open. If there is any uncertainty in the matter, the front should be opened and the throttle valve started slightly, when the escaping steam can be at once seen.

## CHAPTER IX.

### **Defective Draft Appliances.**

*Q. If a petticoat pipe becomes displaced, how should it be readjusted?*

A. The petticoat pipe is used for the purpose of obtaining an even draft over the whole surface of the grates and through the whole nest of tubes. If the pipe is too high, the greater portion of the draft will pass through the lower rows of tubes and pull upon the front end of the fire. If it is too low, the strongest draft will be through the upper rows of tubes and the pulling will be at the rear end of the firebox. The displacement of the petticoat pipe is, therefore, readily detected both by the action of the fire and the choking of the tubes, where there is the least draft, with ashes and cinders.

From what precedes, it is evident that if there is an excessive draft through the lower rows of tubes, the petticoat pipe should be lowered; and, if this excessive draft is through the upper rows, it should be raised.

*Q. If a diaphragm or deflector plate in the smokebox becomes misplaced, how should it be readjusted?*

A. The service rendered by the diaphragm in the front end of an engine is identically the same as that of the petticoat pipe, namely, the production of an even and uniform draft through the grates and tubes. This uniformity is obtained by the adjustment of the lower edge of the diaphragm, which is a separate sheet from the main body.

When the present form of front end was first introduced, this lower sheet was movable and could be raised and lowered by a system of levers under the control of the engineer in the cab. It is now bolted to the main plate in a way that permits of a limited amount of motion.

The displacement of the diaphragm is indicated in the same way as that of the petticoat pipe by the uneven action of the draft upon the fire, and a possible collection of cinders in the tubes that have an insufficient current of gases passing through them to keep them clear. If the diaphragm is too high, it will cause an excessive draft through the top rows of tubes and, if it is too low, the same results occur with the lower rows.

If, then, there is an excessive draft through the upper rows of tubes and at the rear end of the firebox, the diaphragm should be lowered. If the reverse is the case, and the excess of draft is through the lower rows, the plate should be raised.

It is impossible to give any general directions for the adjustment of this plate or the petticoat pipe that will make it possible to set it to the desired position without trial, as this will depend not only upon the type of engine, but the service which it may be called upon to perform, and the quality of the coal that is to be burned. The form of diaphragm and front end recommended by the American Railway Master Mechanics' Association is shown in Fig. 55.

*Q. What should be done if the netting becomes clogged or broken?*

A. The clogging of the netting is apt to interfere seri-



ously with the steaming qualities of the boiler, besides adding to the danger of causing a blowback of the fire into the cab, which is likely to injure the men.

The clogging is usually due to the use of an excessive amount of oil in the cylinders. It does not occur so frequently where an automatic oiler is used as where the cylin-

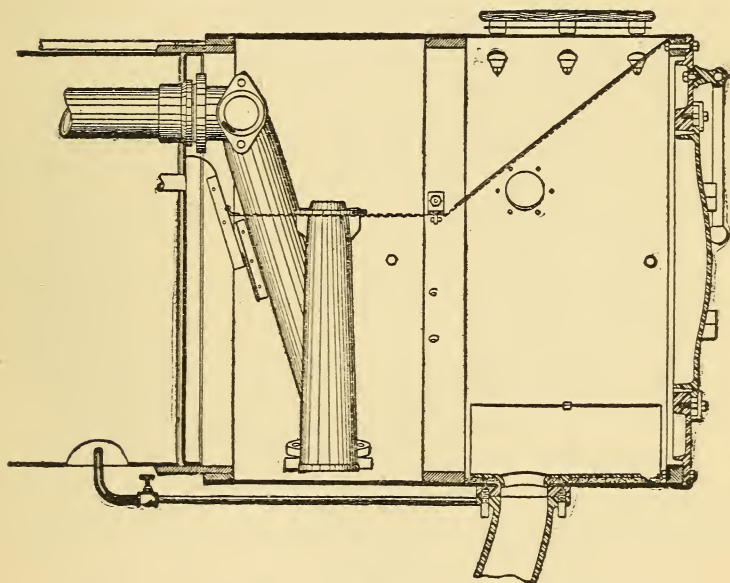

FIG. 55.—THE MASTER MECHANICS' FRONT END.

ders are lubricated from cups in the cab. With this form of lubricator, the opening of the throttle immediately after the oil has been introduced, is apt to throw it out at the exhaust nozzle and spatter the netting.

When this clogging has occurred, the netting can usually be cleaned by building a light fire on the top of the same.

Other forms of clogging can ordinarily be removed by beating.

If the netting has been cut or worn away so that there are holes in it, the danger is that of throwing large sparks out into the air and setting fire to the neighboring property. The precaution to be taken, when this happens on the road,

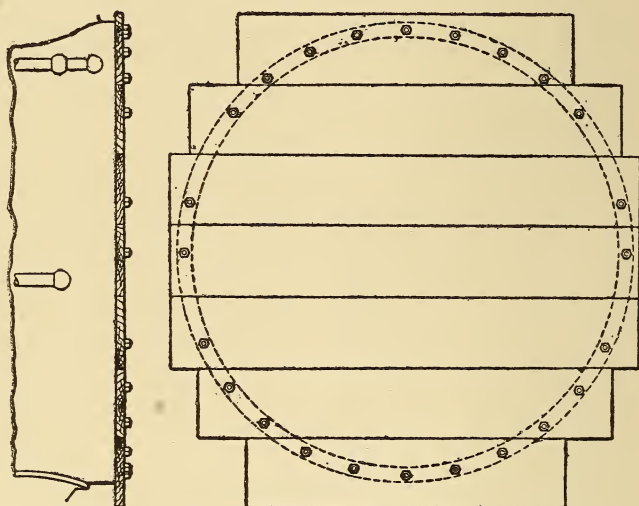

FIG. 56.—BOARDING USED TO REPLACE BROKEN FRONT CASTING.

is to work the engines as easily as possible when passing through districts where there is danger of igniting a fire, and have the netting replaced with new as soon as the terminal is reached.

*Q. What should be done with a broken front?*

*A.* This is an accident that rarely happens except as the result of a blow, such as a collision, and it is usually accom-

panied by other damages. The broken front may itself be repaired by replacing it with boards held by the studs and nuts previously used to hold the front, as shown in Fig. 56.

Such boarding will only be serviceable for a short time owing to the danger of its being burned by the heat and cinders of the smokebox. It may, however, be made to serve until the terminal is reached provided the engine is worked easily.

*Q. What are the causes of the exhaust apparently coming out of one side of the stack?*

A. It may be due to the exhaust nozzle being set so high that the steam does not properly fill the stack. Or if either petticoat pipe or nozzle is out of line the same result will be produced.

*Q. What will be the effect of the steam not properly filling the stack?*

A. It will lower the steaming qualities of the engine and the vacuum in the smoke box will be irregular in its formation and action. The reason for this is that the blast produces the partial vacuum in the smokebox by induction, just exactly as the jet of steam in an injector lifts the water from a tank. If, then, the jet does not fill the stack, the space about it serves as a means of sluggish flow of the gases, with the result that the vacuum is lowered by a very considerable amount. This is why it is so important that there should be a proper adjustment of the size and portion of the exhaust nozzle relatively to the height and diameter of the stack.

## CHAPTER X.

### **Injector Troubles.**

*Q. What should be done if the injectors fail to work?*

A. That is a condition often existing with one injector, but as every locomotive is equipped with two, it rarely happens that both are disabled at the same time. When it does happen, however, the safe course is to stop before the water gets so low as to expose the crown-sheet and deaden the fire so that steam may not be generated, and then blow out at the safety valves.

The first thing to be done is to see that there is water in the tank. If there is, take down the hose and examine the strainer to see that it is clean. The accumulation of dirt in the strainer is probably the most common cause of the failure of the injector.

If the strainer and pipe are clean, examine the injector itself for defects and foreign matter. If the trouble is irremediable, the fire should be deadened by throwing on earth, and the engine prepared to be towed in.

*Q. If the injector fails to work when there is a full pressure of steam upon the boiler, how can the trouble sometimes be remedied?*

A. By reducing the steam pressure. If the delivery of water to the injector is so scanty that the supply is insufficient to condense the high pressure and high temperature steam, it may be sufficient to do this condensation with steam of lower temperature and thus work the injector.

*Q. What are some of the principal causes of the failure of injectors to work?*

A. Leaky pipes are apt to cause an injector to break. If there is a leak in the feed pipe leading from the tender tank to the injector, air may be drawn in such quantities that the water will not rise to the height of the instrument. Small leaks of this character can usually be stopped or checked by wrapping the pipe with cloth and wetting it.

If the leak is not enough to entirely check the flow of the water it may be sufficient to give an elasticity to the stream in the delivery pipe that will prevent it from opening the check valve by causing air to enter and mingle with the water. Such air may enter at other points besides the suction pipe, so that in case of an injector failure all parts should be examined for leaks.

In making this examination especial attention should be paid to the packing about the suction pipe valve where a leak is very likely to occur.

Another cause of the failure of injectors is the accumulation of scale on the tubes. This is especially apt to occur when carbonate of soda is put in the tank in order to soften the deposits in the boiler. The precipitation of the scale takes place as soon as the water is heated, and so more or less will adhere to the interior portions of the injector.

Again, there may be some obstruction in the delivery pipe. It may be choked with scale or foreign substances or the check valve may be clogged in the same way. It is not an uncommon thing to find large deposits of scale at the opening of the delivery pipe into the boiler and, if the check

valve is on the inside, this scale may interfere with its opening to the full amount needed for the free passage of the water.

When an injector refuses to work under these conditions it may sometimes be made to operate by opening the squirt valve. This affords an extra relief for the water and may be all that is needed to make the injector deliver some water to the boiler, though it involves a considerable waste unless it can be led back to the tank.

A clogged strainer may also stop the flow of water so that the injector will not work. This clogging is, of course, due to the presence of dirt in the water, and this dirt may be drawn in and lodged in the tubes so that they cannot perform their proper functions with the result that the injector will not work. Or the flow of water may be checked by the improper regulation of the valve in the suction and steam pipes.

Finally, there are a number of conditions in which the injector may fail, due to the condition of the steam that is delivered to it.

If the boiler is foaming or priming and the steam comes to the injector laden with water held in suspension, the injector will be almost certain to fail to work. This is due to the fact that the operation of the injector depends upon the high velocity with which the steam issues from the admission nozzle. The presence of large quantities of water in the steam will have a tendency to decrease this velocity and may lower it to such an extent that it cannot force the feed water into the boiler.

The same thing holds true if the temperature of the feed water is too high. It must be low enough so as to condense all of the steam delivered from the nozzle. In case this is not done there will be a surplus of steam existing in the body of the feed water which will give the latter an amount of elasticity which will not permit it to open the check valve and enter the boiler. The stream of the feed from the injector to the check valve should be solid water without any intermingling of steam or air.

This is the reason why care should be exercised in the use of the heater for raising the temperature of the water in the tank.

*Q. What should be done under these various conditions in order to get the injector to work?*

A. If the failure is due to air leaks they should be stopped by wrapping the leaky hose or pipe with a wet rag, which may be rendered still more impervious to the passage of air by rubbing it well with soap. If it is found that the leak is a result of defective packing the latter should be tightened.

Dirt in any part of the piping or apparatus should be cleaned out.

If the boiler is foaming so that the injector will not work, the trouble may be sometimes checked by shutting the throttle and allowing the water to settle. The use of the injector alone may not cause the water to rise sufficiently to break the action. If this can be done the injector may be used intermittently with the engine until a water

station is reached, the locomotive being handled in accordance with the answer on page 109.

It also sometimes happens that, where the water is foaming badly, the injector can be started and some water be forced into the boiler before the injector will break. Under these circumstances the injector may be started at frequent intervals, thus getting a little water at a time into the boiler.

If the temperature of the water in the tank is so hot that the injector cannot handle it, the only way will be to cool the water. This may be done by running to the first water tank if the water in the boiler is high enough to do it. If the distance is too far a stop should be made at the first stream, and by allowing a portion of the water to run out of the tank, a small quantity of fresh will cool the remainder sufficiently to make it possible to work the injector.

*Q. If the injector gets water but cannot force it into the boiler, what may be the trouble?*

*A.* Any of the defects named in the answer on page 135, when existing in a minor degree, may produce this result.

Some of these defects may develop slowly and the action of the injector becomes less and less efficient, until at last it will cease to work. This is especially apt to be the case with air leakages. The injector can force a small amount of air into the boiler with the water, but a rapidly growing leak will cause it first to deliver less and less water until it can merely cause it to appear at the overflow and finally stop altogether.



The same thing holds true of an accumulation of scale at the check valve. For these reasons troubles of this kind should be remedied at once and not be allowed to increase to such proportions that a failure upon the road can take place.

*Q. What is the cause of injectors losing water at the overflow while working?*

A. In the case of double-tube injectors, such as the Metropolitan, this loss may be due to the overflow valve leaking, which is there subjected to boiler pressure. With open overflow injectors, it may be caused by worn or clogged tubes.

Sometimes after an injector has primed and the steam valve has been opened, it will continue to throw water out at the overflow and that, too, at an increased velocity. In such a case the loss at the overflow can be checked by partially closing the water supply.

In such injectors it may be that steam will escape from the overflow when the injector is at work. This will do no harm when the escape is slight and will probably be found to be due to a leaky priming valve. If such is the case it can stand until the injector is in need of cleaning or other repairs.

*Q. If the check valve is stuck open what should be done?*

A. It is sometimes possible to jar it shut by striking on the casing with a soft hammer or block of wood. In case this proves to be ineffectual the valve in the suction pipe

ahead of the injector should be closed, or the injector kept at work at all times.

*Q. What objection is there to allowing the hot water from the boiler to leak back into the tank from a check valve that is stuck open?*

A. The water in the tank will soon become heated to so high a temperature that neither injector can be made to work.

*Q. How can scale be removed from injector tubes?*

A. The parts coated should be placed for a short time in a bath of muriatic acid, and then thoroughly rinsed in clear water. The acid will loosen the scale and cause it to fall off. The rinsing is needed to guard against subsequent corrosion.

*Q. What should be done in case a check valve is knocked off?*

A. The fire should be killed at once so as to protect the firebox sheets. This may be done by drawing the fire or shoveling damp earth in on top of it.

*Q. What can be done in case a check valve in the delivery pipe from the injector becomes cocked so that it will not seat?*

A. It is possible that an injector with an independent lifting jet could be made to hold the steam in the boiler and start at any time against that pressure. But with injectors that do not have such a jet it is probable that the steam and water would flow back, and have the same results as a broken check. This is, of course, on the supposition that there is no check between the injector and

the main one at the entrance of the delivery to the boiler. Such a check would neutralize the effect of any displacement of the main one. Sometimes a cocked valve may be made to straighten and subsequently seat, by cutting down the delivery of the injector to as low a point as possible and then opening it wide. The sudden influx of water may open the valve enough to loosen it and permit it to square itself and then come back fairly on its seat.

*Q. What should be done in case the pump fails to work?*

A. Attention may be called to the fact, as a preface to the answer to this question, that the pump has been practically discarded from modern American locomotives, and the injector substituted in its place. When the pump is used it consists ordinarily of a solid plunger attached to the cross-head and moving to and fro in a hollow cylinder a little larger than its own diameter. Leakage is prevented by a stuffing box, as in the case of the piston rods or valve stems. The valves are usually very strong and the delivery valves are frequently in duplicate and set in series. This is in order that any leakage through one may be checked by the other.

Of course the pump is only at work when the engine is in motion.

The first things to be looked to in case the pump ceases to work are the lazy cock and the condition of the water in the tank. The former should be open and the latter of sufficient depth to feed the pump. If these two points are found to be all right, the next thing is to open the air cock in the delivery pipe. This will relieve the pump of some

of the pressure against which it must work while forcing water into the boiler, and may start it when it would be impossible to do so if such a relief were not afforded. As soon as a solid stream of water is seen issuing from the air cock, the latter may be closed and the pump will ordinarily deliver to the boiler without further trouble.

If the opening of the air cock fails to start the pump the next place to look for the difficulty is in the suction valve. If this valve opens, water can hardly fail to be delivered, but if it is stuck shut, none can enter the pump. It can sometimes be started by jarring with a hammer, but, owing to the difficulty of reaching it from the running board, it is sometimes dangerous to attempt to strike its casing when the engine is in motion.

The safe plan, then, is to slacken speed and to strike the casing while walking alongside. If this does not remedy the trouble, a stop must be made and a search instituted.

While doing this the packing about the plunger should be examined to see that it is not leaking to such an extent that the air admitted prevents the suction valve from opening. In case it is, it should be tightened and the cure will probably be found to be effected.

The next thing to be done is to take down the strainer and see that it is clean. This proving to be all right, next remove the bolts holding the suction pipe to the suction valve casing. Take out the casing and remove the valve, and see that it is not jammed, stuck or battered, but is perfectly free to move.

If this is all right, do the same thing with the delivery

valves; and, then, if the pump fails to work, the trouble will probably be found to exist in the check valve, which can

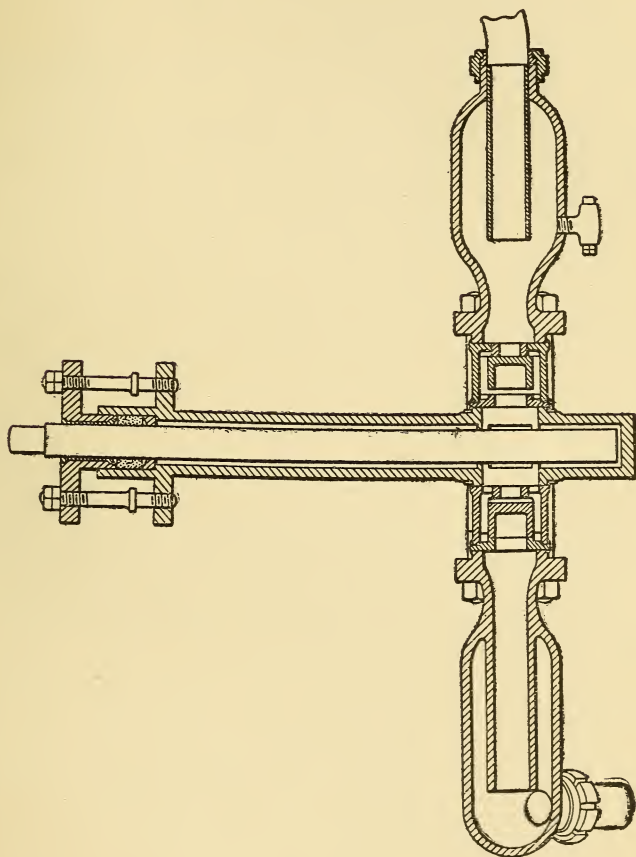

FIG. 57.—SECTION OF LOCOMOTIVE BOILER PUMP.

only be examined when there is no steam pressure on the boiler.

The delay implied in the above answer would not ordi-

narily be incurred because of the fact that the locomotive is invariably fitted with two pumps, and if one fails the other can be put into service, and it is not at all probable that both will fail at the same time.

When, however, one pump does fail steps should be taken at once to put it into working order again, so as to have the usual reserve against emergencies. The examination of the strainer can ordinarily be made during the time occupied in taking water, and the valves can be taken down and examined during the time allowed for lunch, if there is such an allowance, on a passenger run, or while waiting at passing points on a freight train. The construction of an ordinary locomotive pump is shown in Fig. 57. The valves are of the most substantial construction and all parts are so designed that they can be easily and quickly removed for inspection and repairs. It will be noticed that there are two air chambers; one for the delivery and the other for the suction. The use of the former is to give a comparatively even pressure upon the stream flowing into the boiler; while the latter serves the same purpose in preventing the pounding of the valves and keeping the flow of water steady, especially at high speeds, when the capacities of the valve openings will be taxed to their utmost. It will be readily understood that, where the valves are opening and closing several hundred times a minute, it is of the utmost importance that there should be no break in the stream of water.

## CHAPTER XI.

### Accidents to Cab Fixtures.

*Q. What should be done in case the cylinder lubricator fails to work?*

A. The lubricator should be disconnected and the cylinders oiled through the feed pipes in the same way as that employed with the old-fashioned cylinder lubricators.

Just how this can be done will depend somewhat upon the lubricator that is used. It will usually be found to be possible to so disconnect it that the work can be done as described.

Take the Nathan lubricator shown in Fig. 58, as an example. If the lubricator stops feeding oil on account of the breakage of the glass or for any other reason, the valves *A* and *B* should be closed. This cuts off the flow of oil through the glass or passage affected, but does not in any way interfere with the working of the balance of the lubricator.

Special tallow cups *C* are provided on these lubricators, which may be opened and used in the same way as the old-fashioned cab oilers when the engine is on a down grade or at any other time that it is drifting with the throttle closed.

This feature can also be used at any time to supplement the supply of oil to the cylinder in any quantity, as in the case of common non-automatic lubricators. This method can be used, with possibly some changes in the detail of the

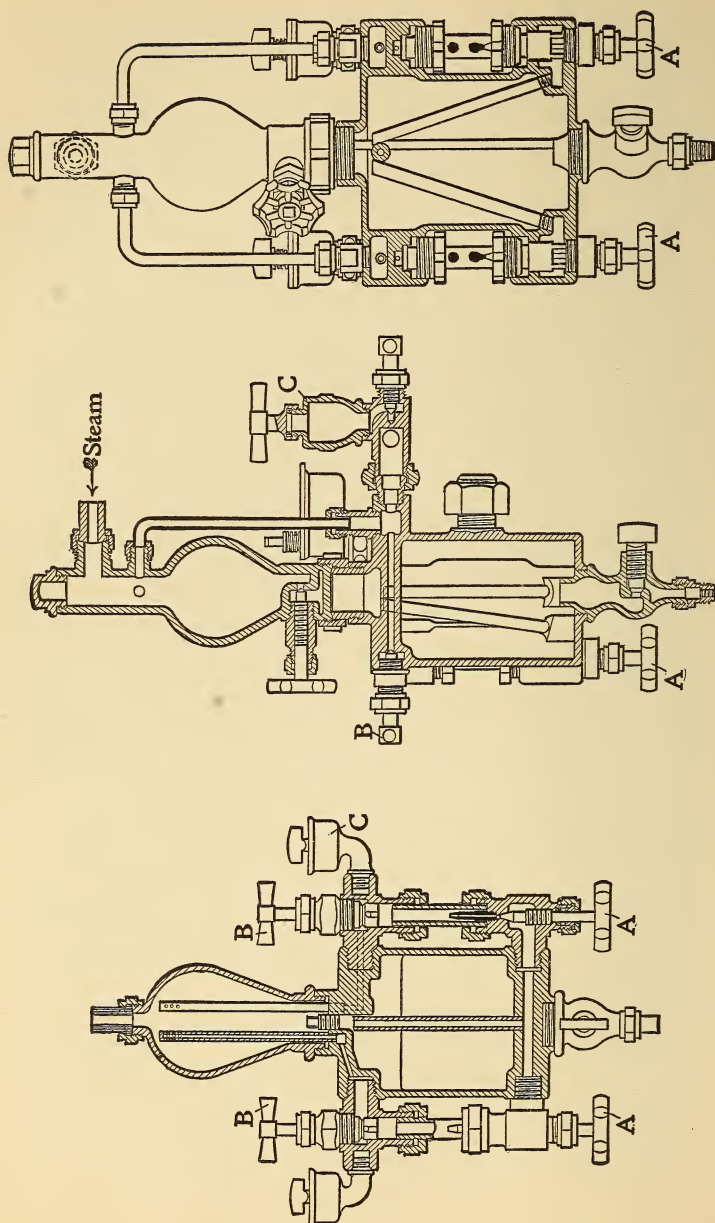

FIG. 58.—THE NATHAN CYLINDER LUBRICATOR.



operation and arrangement with all sight feed automatic lubricators.

*Q. What may be the cause of an irregular action of an automatic sight feed cylinder lubricator?*

A. If the fitting of the choke plugs is too loose, or the feed holes are too large, the result may be an intermittent feed. This hole should not be more than 1-32 inch in diameter. An obstruction in the equalizing tubes will also cause an irregular action. These tubes should be kept free and clean and the choke plugs tight.

*Q. What is the first thing to be done in case a lubricator fails to work?*

A. The bottom cocks should be opened and a full head of steam turned on so as to blow it out. If this fails to put the instrument in working condition, take out the sight feed glasses and examine the feeders at the bottom to see that they are clean and clear. If this fails it should be disconnected as per the instructions in the answer on page 145.

*Q. In case a Nathan lubricator fails to feed, but the feed glasses fill with water when not at work, the said water all leaving the glass when attempting to use the feed what may be the matter?*

A. According to the makers of the device, such trouble may be "caused by not having full steam pressure on the lubricator when the engine was moved out of the roundhouse. The water valve was opened, but not the steam. In this condition there was a direct opening from the lubricator to the steam chest through the water valve, drawing the condensed water from the condenser and then siphoning the

oil through the water tube out of the oil chamber. This will cause the water from the sight feed glasses, together with any oil that may be on top of the same, to be drawn into the oil chamber. This will last until the oil chamber is solid full, then the feed glasses will fill up with water again, and if the condenser has in the meantime regained condensed water, the cup will feed oil again. The remedy is to open the steam valve full before the engine is moved.

*Q. What should be done if the glass of the water gauge breaks?*

A. If the fittings are not supplied with automatic self-closing valves, this is a minor accident that may cause serious injury to the enginemen, especially to the fireman, on account of the pieces of flying glass. The only thing to be done is to close the cocks at the top and bottom of the fitting, thus shutting off the escape of steam, and then use the gauge cocks to determine the water level for the remainder of the run.

*Q. What is the principal indication of a defect in the water glass of a locomotive?*

A. When the engine is in motion the surface of the water in the glass is constantly rising and falling, and if, at any time, it becomes stationary, it is a sure sign that the bottom opening of the glass is clogged to a greater or less extent.

*Q. Is the fact that the surface of the water is moving up and down when the engine is in motion a sure sign that both top and bottom openings of the glass are free?*

A. No. The top opening may be nearly or quite closed, and if the bottom one is clear the water will continue to rise

and fall in the glass, although it will not correctly register the water level in the boiler. For this reason the water gauges should be kept free at all times, and be frequently used to check the indications of the water glass.

*Q. In case a water glass is broken how can a new one be cut to fit in its place?*

*A.* A piece of hardened steel with a bent point should be used to make a scratch around the inside of the tube. The latter can then be easily and accurately broken at the point so marked.

Another way that is said to be equally effective is to wet the sulphur end of an ordinary match and make a mark around the inside of the glass at the point where it is desired to break it. Then hold the glass at this point in the flame of a candle or another match, revolving it in the meantime so as to heat it evenly over the whole circumference. It is said that it can then be readily broken with the fingers at the point marked, with a smooth and even fracture.

*Q. What precautions should be taken in replacing a broken water glass?*

*A.* If the boiler is hot at the time the replacement is made the packing at the ends of the glass should be screwed up very loosely so that there is no possibility of the unequal expansion between the glass and the frame causing an excess of pressure on the former and breaking it. After it has been put in position it should be allowed to stand long enough to become as warm as it will through contact with the heated parts of the frame. Then start the upper valve so as to allow a mere leakage of steam into the glass and

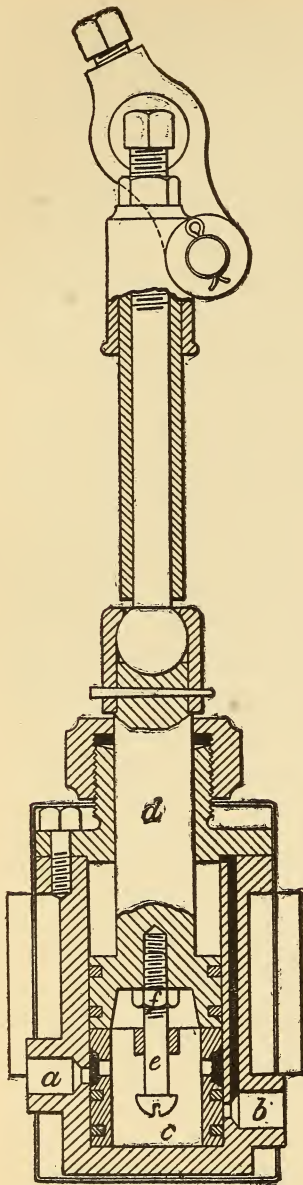

FIG. 59.—THE GOLLMAR BELL RINGER.

permit a considerable amount of condensation to collect at the bottom before starting the lower valve in the same way. When the water level indicates approximately that of the boiler the valves may be gradually opened until they are in their normal working position.

The packing glands may then be screwed gently home until all the leaking has been stopped, remembering, however, that it is better to have a leak than to screw the packing home too rapidly, since the glass should be perfectly free to expand lengthwise and diametrically in order to adjust itself to the normal working condition and be without strain.

*Q. What should be done in case a bell ringer refuses to work?*

*A.* The real cause of the failure of this part of the engine mechanism is usually due to a neglect on the part of the engineer or fireman to give the device proper care. The usual

trouble is dirt. Whether compressed air or steam is used oil for the lubrication of the cylinder is needed, and the trouble usually is not that an insufficient quantity is supplied but that too much is used and that, too, in doses larger than the cylinder can take care of. The result of such treatment is that the exhaust pipe soon becomes filled with cooked oil so that the pressure cannot escape as the bell pushes the piston down and the apparatus is choked. The first step to take, therefore, when the bell ringer fails to work is to take it apart and see that it is clean.

As these bell ringers are usually worked by a single acting piston whose valve is moved in one direction, at least, by the weight of the bell, the mechanism is ordinarily very simple. A failure to act may also easily occur. In the Gollmar ringer, for example, shown in Fig. 59, the steam or air is admitted through the port *a* to the interior of the hollow cylindrical valve *c*.

As the piston *d* is raised by this pressure, the end of the stem, *e*, strikes against the lug of the valve *c*, through which it passes. In order that the exhaust may escape it is necessary that this valve *c* should be raised high enough so that its lower edge shall be above the exhaust opening *b*.

The stem *e* after being adjusted is held in its proper position by the check nut *f*. If, then, this latter works loose and the stud *e* unscrews, it is evident that the valve *c* will not be raised high enough for the exhaust to escape, which will result in the stopping of the ringer.

Stoppage may also result from a leakage of the piston packing ring, but this latter will come on so slowly and will

manifest itself by the gradual weakening of the action of the device so that there should be no difficulty in this case in locating the trouble.

The mechanism is so simple that when it refuses to work the cylinder head should be taken off and all parts removed. By measuring the height of the exhaust port *b* above the bottom of the cylinder and knowing the stroke of the piston, it is an easy matter to subtract the former from the latter and ascertain whether the stem *e* is adjusted to give the proper lift or not.

*Q.* *What should be done in case a steam gauge becomes broken or fails to indicate the actual pressure?*

*A.* This is a minor accident that is of comparatively little moment. While it is desirable that the gauge should be accurate in order that the enginemen may be able to regulate the fire and run most efficiently it is quite possible to run safely without any steam gauge at all. The failure of this fixture is comparatively rare, but as it is subject to constant deterioration it should be tested frequently and readjusted to proper indication. If, however, the gauge should be broken as the result of any accident the steam should be shut off from it and the run completed by the indications of the safety valve. Incidentally, the noise of the steam escaping from the top gauge cock should afford an approximate indication of the steam pressure in the boiler. This, however, requires an ear trained by long and close observation.

CHAPTER XII.  
**Tender Accidents.**

*Q. What should be done in case of the breakage of the draw-bar between the engine and tender?*

A. If the engine has safety chains these will usually have sufficient strength to haul the tender, but may be insufficient to do the same with a heavy train. Should there be no safety

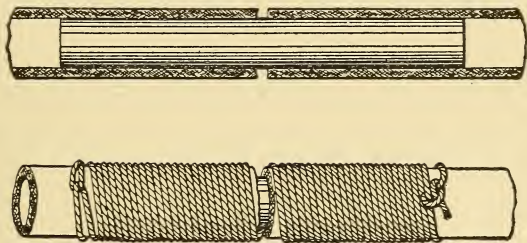

FIG. 60.—SPliced TENDER HOSE.

chains, the engine and tender may be held together by chaining the tender frame to the deck.

*Q. What should be done with a broken or burst hose connection between the engine and tender?*

A. As there is nothing to burst this hose since it is subjected to no internal pressure, any rupture to which it may be subjected is likely to be caused by a parting of the engine and tender, as in the breakage of a drawbar.

If the hose is not torn in two it may be temporarily repaired by laying a piece of leather or heavy cloth over the hole and binding it down with strong twine or cord.

If the hose is torn entirely in two, it may be possible to repair it by wrapping it with leather or heavy cloth as before, or by inserting a piece of hose into each of the two severed ends and binding the hose down tightly against it. A short length of iron pipe may also be used and wound in place in the same manner, as shown in Fig. 60.

*Q. What should be done when a tender truck breaks down?*

A. If it is the forward truck, it should be removed and

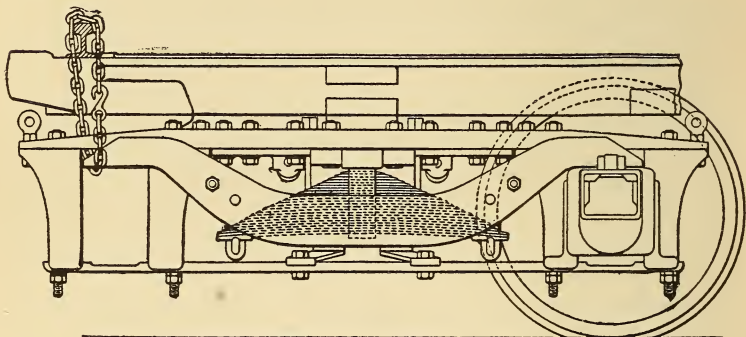

FIG. 61.—CHAINED UP TENDER TRUCK.

the front end of tender frame may be chained to and held by the rear end of the engine frame.

If it is the rear truck that has failed it should be replaced by a car truck, if one is available. If not, the tender should be jacked up and the front truck put at the rear, and the front end chained to the engine frame as already described.

When a tender has been chained in this way the engine should be run very slowly and cautiously.



*Q. What should be done if an axle under a tender truck breaks?*

A. If it is a front axle that end of the truck should be chained up to the frame of the tender so that the wheels will be clear of the rails, as shown in Fig. 61. These must also be secured so that there is no danger of the broken parts falling down upon the track.

Should it be a rear axle that is broken the frame should be jacked up and the truck turned around, after which it should be chained and secured as already directed.

When possible it is safer and better to substitute a car truck for the one that is disabled.

*Q. What should be done if a tender wheel is broken?*

A. The pair of injured wheels should be chained or blocked so that they cannot turn and the engine run carefully with these wheels sliding to the nearest siding or telegraph station.

*Q. When an engine or the tender is disabled by the breakage of a wheel or axle, and the rear wheel of a truck or the rear driving wheel is damaged, is it safe to run the engine backwards?*

A. It is not.

*Q. If the tank valve has become broken or disconnected so that it has dropped down on the seat, how may it be unseated?*

A. It may be done by opening the heater wide and blowing steam in with force. This should throw the valve out of position. After which the heater valve should be immediately closed to avoid the danger of bursting the hose.

## CHAPTER XIII.

### Miscellaneous Accidents.

*Q. What are the first duties of the engineer in case of a breakdown upon the road?*

A. The first thing to be done after stopping is to see to it that the train is protected by flagmen in both directions in case of a single track road, and in the rear on a double track. If the nature of the accident is such that both tracks of a double track road are in any way obstructed, flagmen should be sent to the front as well as to the rear. Should the breakdown be one that is likely to require much time to put the engine in running order, word should be sent to the nearest telegraph station, flagging a passing train to send the message if necessary.

The next thing to do is to determine the character of the mishap and locate the damage; ascertaining whether it will be necessary to ask for outside assistance, and, if it will be, sending to the nearest telegraph station for the same at once. Finally work should be started immediately to put the engine in condition to be moved. There is almost always something that can be done before outside help arrives that will facilitate the preparations and shorten the time during which the disabled engine will be blocking the tracks.

*Q. When running over a slippery rail will it be necessary to keep a continuous stream of sand running?*

A. If the engine is fitted with a pneumatic sander that is so adjusted that an exceedingly fine stream of sand can be

delivered to the rail at all times it may be necessary to maintain such a flow continuously. But, with the common sand valve, gravity flow sander, such a fine regulation is impossible, and better results can be obtained by opening and closing the sand valve than by permitting an uninterrupted stream to flow down upon the rails. The objection to the latter method is that it wastes the sand and makes the train pull hard; while, with the intermittent method, the excess that runs down upon the rails when the valve is opened will cause enough to stick to the drivers to maintain the required adhesion to prevent slipping over short distances when the valve is closed. No rule can be given for this, as the work must be done according to the condition of the rail, and the speed of the train, but ordinarily an opening made once in every ten or fifteen rods will suffice.

*Q. How can a dead engine that is being towed be pumped up so that it can move itself?*

A. If the engine is to be towed for a short distance only, it may be done with all of the connections intact, and with the pistons moving to and fro in the cylinders. Under these conditions if the reverse lever is thrown into a position opposite to that in which the engine is moving the pistons will draw air in at the exhaust and pump it into the boiler (the throttle being open). A pressure will then be accumulated therein that can be drawn upon to move the engine for short distances until the supply is exhausted.

*Q. What should be done if an engine becomes derailed?*

A. It is impossible to give explicit directions for putting a derailed engine back upon the rails, as each case calls for a

special method of procedure. Only general instructions can, therefore, be given.

The first thing to be done after the derailment occurs is to examine the situation carefully and decide whether or no it will be necessary to send for assistance in order to replace the machine on the rails, and also what kind of assistance will be needed. Sometimes an engine may be off the rails in a way in which it is helpless to assist itself, but where a pull from another engine will put it back. At others it must needs be lifted by a traveling derrick.

In a general way it may be stated that an engine can be most easily put back upon the rails over the same path that it followed in leaving them.

Where jacking must be resorted to, the amount of lift should be reduced to a minimum. As the wheels are the important elements in the case, they should begin to rise as soon as the jacking is begun. That this may be so, blocking should be placed beneath the boxes and above the pedestal binders of the driving axles, so that the wheels may start to rise at once. If this is not done the weight of the engine will have to be lifted the distance between the binders and the oil box before the work will have any effect on the wheels.

As soon as the wheels begin to rise, keep the space between them and the ground well filled with plank and blocking, so that no settlement may be possible through an accident or settling of the jacks themselves. Where the engine is to be moved a short distance transversely of the

tracks, traveling jacks will be found to be a great convenience.

If it is not found to be necessary to jack up the engine, portable frogs may be used to replace the same. These should be put in front of the wheels and the locomotive moved back in the direction opposite to that followed when it left the rails.

It should also be borne in mind that sudden movements of a derailed engine are apt to make matters worse rather than better. The engine should always be moved slowly and carefully so that it may be instantly stopped in case things go wrong.

If more than one pair of wheels are off the rails and an attempt is to be made to replace the machine with frogs, these should be put in front of the wheels that are outside the rails, and blocking be used in front of those on the inside, provided there are not enough frogs to serve each with one.

These are a few of the general principles that are to be applied in putting a derailed locomotive back upon the track. Just how they are to be used in detail will depend upon the conditions of the accident, the local surroundings and the good judgment of the man in charge of the work.

*Q. What are some of the forms of wrecking frogs that are valuable for use in replacing derailed engines upon the tracks?*

A. Fig. 62 shows a common wrecking frog that is used for the wheel on the outside of the rail in connection with

the wedge, Fig. 63. The former is made of a heavy bar with legs that can straddle the rail and having a spur at the end at the base to fix into a tie to prevent slipping. The wedge is

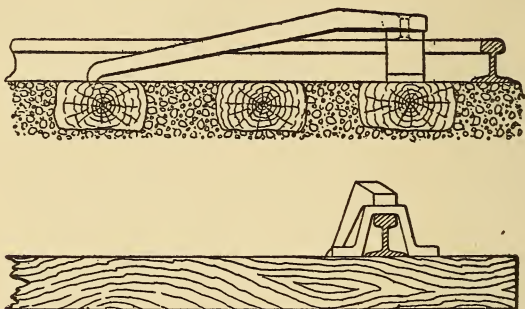

FIG. 62.—COMMON WRECKING FROG.

made of a piece of hard wood shaped as shown in Fig. 63, and plated on the top and bottom to protect it against indentation by the flanges. This is used for the wheels on the inside of the rails and serves merely to lift them to the

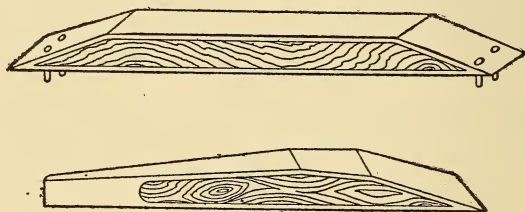

FIG. 63.—WRECKING WEDGES FOR RE-RAILING WHEELS.

height of the rails, it being unnecessary to carry the flanges over the top of the same as in the case of the wheels outside the rails with which the frog is used.

The wedge is prevented from slipping by spurs in the bottom that are pressed into the ties. It may be rectangular or triangular in plan, the latter being used at switches where converging rails would make the use of a rectangular one impossible.

In addition to these common frogs and wedges there are a number of others upon the market that are rendering efficient service.

Among these are the Alexander frog, Fig. 64, which is

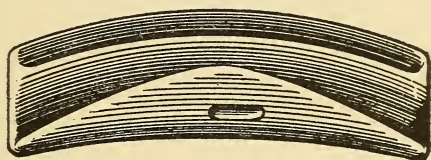

FIG. 64.—THE ALEXANDER WRECKING FROG.

made of pressed steel and is very strong and comparatively light.

The Cooke frog, Fig. 65, is triangular in plan and fits over the rail, having spurs to prevent slipping. It thus forms an inclined plane upon each side of the rail for the elevation of the wheels. These frogs are used in pairs and are rights and lefts.

*Q. In case an engine is derailed, injured, or in such a position that the sheets and tubes cannot be kept covered with water, what should be done?*

A. The fire must be drawn or extinguished.

*Q. How can this best be done?*

A. Either by cleaning off the grates by drawing the fire out at the door or smothering it with a thick layer of damp earth.

*Q. Why not quench the fire with water?*

A. The intense heat of the fire will cause such a sudden generation of steam that it will not only put the person throwing on the water in great danger, but will be apt to scatter the live coals in a way likely to set fire to neighboring

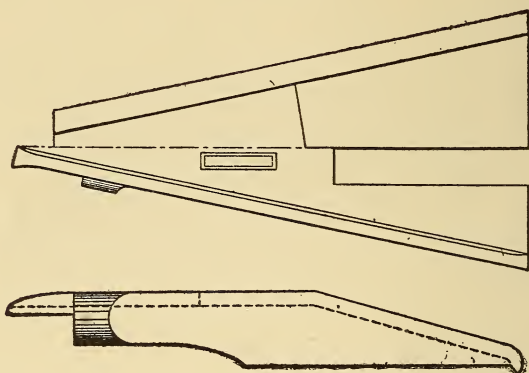

FIG. 65.—THE COOKE WRECKING FROG.

objects. In addition to this, the sudden cooling of the fire-box sheets has a tendency to crack them.

*Q. When danger ahead threatens a train, what course should be pursued in making a quick stop?*

A. The throttle should be closed, the air brake set to an emergency application, the engine reversed, sand applied to the rail and the throttle opened, if the air brakes are not applied to the driving wheels. Otherwise the throttle had best be left closed.



*Q. What are some of the causes of hot bearings?*

A. Hot bearings may be due to too great a pressure upon the journal; to a binding of the boxes or the brasses causing the shaft to be pinched; to defective lubrication; to badly fitting brasses, and to dust and grit working in between the rubbing surfaces.

*Q. What should be done if the main axle bearing runs hot?*

A. As soon as the bearing manifests signs of heating it should be copiously supplied with oil, and if the boxes are fitted with water pipes that will throw a stream of water upon them, that leading to the hot box should be opened. If the water and the oil so applied fail to keep the journal cool, but its temperature continues to rise until there is danger of melting the babbitt or brass, the box should be relieved of a portion of its load. This may be done by driving a wedge in between the spring saddle and the frame.

Sometimes heating may be due to the binding of the box in the wedges. If this is the case, any further heating merely makes matters worse, and relief may sometimes be obtained by slacking off the wedges.

*Q. What should be done in case a rod brass becomes hot?*

A. If the heating is discovered before the babbitt melts, the trouble may usually be relieved by loosening the brasses a little, cooling off with water and giving the heated bearing a copious supply of oil.

Should the bearing become so hot as to melt the babbitt before the trouble is discovered, it is best not to stop until it

is all thrown out. Otherwise it will be apt to fill and clog the oil holes. The engine may then be stopped and the rod keys loosened a little, the bearing given a good supply of oil and the run finished. Careful and constant supervision must be exercised, when running in this condition, to avoid the cutting of the pins.

*Q. What should be done in case an eccentric strap becomes hot?*

A. The engine should be stopped and the bolts holding the two parts of the strap in position slackened. If possible, an extra liner should be put in so that the strap bolts can be tightened and rattling avoided. The eccentric should be carefully oiled and the straps allowed to cool slowly, if they are cast iron. Water should not, under any circumstances, be put upon a hot cast iron eccentric strap as it will be almost certain to cause a crack.

Again, in the case of a hot eccentric strap, do not move the reverse lever after shutting off steam. If it is thrown down into the corner as in the usual way when making a stop, the extra stress put upon the straps due to the increased travel of the valve will be very apt to break it. Wait rather until the engine has stopped and the strap bolts have been slackened.

*Q. What should be done if a tender or forward truck axle becomes hot?*

A. It may be cooled with water, after which it should be carefully repacked.

*Q. What should be done if the crosshead or guides become hot?*

A. As there are no means of adjusting the crosshead by which it may be eased, the best course to take is to keep the rubbing surfaces copiously supplied with oil and slacken speed if necessary. Do not throw water on hot guides as it will probably warp them and make matters worse.

*Q. What are the objections to using water for cooling hot bearings?*

A. Water is not a lubricant and does not act as such upon a bearing. It merely serves as a cooling liquid by which the heat generated by the interaction of the journal and the box is dissipated. Meanwhile, there is a rapid wearing away of the parts affected.

Another objection is that the brasses and other parts so cooled are apt to be distorted by a contraction that may be local, so that they will afterwards be more apt to run hot than would be the case had they not been so treated.

As far as the journal itself is concerned it apparently is a matter of no moment whether water is used upon it when it is hot or not. There are no records of journals having failed afterward because they were cooled with water, even though they may have been heated to redness and allowed to stand under the weight of the car while the water was being poured upon them.

*Q. What is a cause of crank pins running hot?*

A. This is most frequently due to badly fitting brasses. It often happens that when the brasses are removed they are improperly fitted by being eased off too much at the top so that they do not have a good bearing there, or by being keyed too tight so as to pinch the pin. If brasses have

been running cool before they were refitted, and do not do so afterwards it is a sure sign that the work has not been done in a proper manner. Satisfactory results are most easily attained by boring the brass a little larger than the pin.

Crank pins will also run hot if the proper quality of oil is not used. If cylinder oil is put in the oil cups in cold weather it is apt to fail in the feeding and cause trouble by allowing the pins to become hot.

*Q. How should rod brasses be filed when worn?*

A. The filing should be such that when the keying is done the two brasses are brought solidly together, metal to metal. If this were to be done by simply filing off the edges of the brasses, they would be apt to pinch the pin at the top and bottom and run hot. For that reason they must be eased off a little at the top and bottom. After the filing has been done the brasses should be replaced in the strap and keyed solid. When in this condition they should whirl easily and freely upon the pin.

*Q. What should be done in case an engine becomes stalled in the snow?*

A. As in many other instances the course to be pursued will depend upon the existing conditions.

If the fuel supply of the tender has been nearly or quite exhausted so that there is nothing wherewith to keep the engine hot, it will be necessary to empty the tender, disconnect the pipes and, as soon as the steam pressure has fallen, allow the water to run out of the boiler either by opening the blow-off pipe or starting a washout plug.

Should there be a tender full of coal or a supply sufficient

for a time, the fire may be maintained and the tender kept supplied with water by shoveling in snow and melting it and keeping the resultant water above the temperature of freezing by opening the heater cocks.

*Q. How should a dead engine be disconnected for towing?*

A. The generally accepted method of disconnecting an engine for towing is to take down the main rods, block the crossheads and clamp the valve stems, leaving all of the side rods in position, if possible.

The reason for leaving the side rods in place is that they serve to balance the cranks and thus neutralize the hammer-blow that would otherwise be delivered to the rail by the unbalanced crank. This corresponds with the condition in which new engines are put when being towed from the shops of the builder to the purchaser, and whose speed of movement over the road is usually limited; a rule which must be observed in the towing of a dead engine.

If, however, the condition of the engine is such as to necessitate the removal of any of the side rods, it should be borne in mind that the corresponding ones upon the other side of the engine must be removed also.

These directions for disconnecting an engine will have to be modified in many instances, dependent upon the nature of the accident which the engine has suffered, and the condition of other parts. It is evident, therefore, that no general directions can be given that will cover every specific case, but that the treatment of each must be distinct and referred to the judgment of the engineer in charge.

*Q. When an engine has been running with one side disconnected, what precautions should be taken in stopping?*

A. Care should be taken that it does not stop at or near the center. The best point to stop will be with the crank pin about one-eighth of a revolution past the center. This is at a point where the valve will be well open and the thrust of the rod upon the pin such as to have a powerful turning effect. At the same time it gives an almost maximum distance to be traveled before the crank reaches the next center, by which time a sufficient momentum will have been obtained by the engine to carry it past the same and thus avoid the annoyance of stopping upon the dead point.

*Q. If an engine that is disconnected upon one side should stop at or so near the dead point that it will not start, what should be done?*

A. The only remedy will be to use a pinch bar and move the engine until the crank is in a position to be moved by the steam pressure upon the piston.

*Q. If the sand pipe on one side of an engine becomes clogged is it advisable to sand the rails from the other side only?*

A. No. If the engine is apt to slip and sand is used on one side only, the catching of that wheel will throw an excessive stress upon the axle which will make it possible to cause bending.

*Q. When an engine is slipping, how should sand be used?*

A. Steam should first be shut off and then the sand valve opened, after which steam may again be admitted to the cylinders.

The reason for this method of procedure is that, when the wheels are revolving at a high speed they acquire a considerable momentum. If, then, the main driving wheels are suddenly stopped by the application of sand, the trailing wheels may bend the side rods.

*Q. What is the cause of pounding in a locomotive?*

A. Pounding may be due to a great variety of causes and these are sometimes far more difficult to locate than blows. One of the most dangerous causes of pounding is to be found in the cylinders when the boiler is foaming or priming. The water thus carried over with the steam fills the clearance spaces and causes the piston to strike a powerful blow at the end of the stroke, which may result in the breakage of the heads unless there is some outlet provided for the escape of such water. Sometimes when the crank pin and crosshead brasses have been refitted, the main rod may be so lengthened or shortened that the piston strikes against the cylinder head.

Cylinder pounding may also be caused by an insufficient supply of oil.

It is impossible to convey by words a true idea of the noise made by cylinder pounding under these three conditions. The pound is, however, different in sound in each instance and peculiar to the cause, but can only be differentiated by the trained ear.

Lost motion in the reciprocating parts is also a prolific cause of pounding. This is usually due to the results of wear. Sometimes such pounds are dangerous and should be remedied at once; at others no immediately serious results

need be looked for other than an increase in the wear of the parts so affected.

Thus, if a pound develops between the piston rod and the piston or crosshead, it should be cared for without delay, as it will be apt to cause a fracture of the piston rod with the resultant breakage of one of the cylinder heads.

A pounding at the wristpin or crank pin is not so serious, but should not be neglected, as it will denote a rapid increase of wear; and, in the case of the crank pin brass, may result in the bending of the pin. In the case of the side rod the pound is not so serious on account of the reduced stresses which it is called upon to carry. In fact side rods with bushings loose upon the crank pins do the principal part of their pounding after steam has been shut off, which is, however, a rattle rather than a pound.

Pounding also occurs in the driving boxes and wedges due to the looseness or improper adjustment of these parts. A loose pedestal brace will also produce the same effect. If a wedge works down so that the box has a chance to partially turn, the latter may catch and hold until some extra stress is put upon it when it will let go and there will be a single blow that will partake of the nature of a crash, though nothing may be broken. Such pounding as this is especially severe on the springs, and will be likely to cause a fracture of the same.

For these reasons care should be taken that the wedges are maintained in a parallel position and in proper adjustment at all times. Finally a loose driving box brass may cause a pound.



In addition to these main causes of pounding, there are a number of minor ones that may be due to the looseness of any of the moving parts, such as eccentric straps, the striking of the springs against rigid portions, also to eccentric rod, link, rocker or valve stem connections. Pounding in the steam chest due to loose packing strips or in the cylinder from the same cause is readily distinguished by the peculiar clicking sound that is produced.

*Q. How can a pound be located?*

A. Pounds due to looseness or wear can best be located by placing the engine on the quarter, the top being the better, blocking the driving wheels, opening the throttle and reversing. As the reverse lever is moved to and fro steam will be admitted first to one side of the piston and then the other, causing such movement of the reciprocating parts as the looseness of the same will permit. By carefully watching such motion the pound can be located. Should this work fail to fix it on one side, it should be repeated on the other.

Of course this method will not locate a pound in the cylinders, since there is not sufficient movement of the piston under these conditions. If the pound is due to foaming or priming it will disappear when the cylinder cocks are opened or the throttle closed. If the piston strikes the cylinder head or the packing rings are broken, the defect can usually be determined by walking alongside or riding on the cylinders when the engine is in motion.

One precept should be borne in mind and invariably acted upon, and that is never to run an engine with a bad pound in the cylinders.

*Q. If driving wheels become locked due to the application of the brake, how can they be started?*

A. If the driver brake is powerful enough to skid the drivers either by the direct pressure which it applies or as the result of jamming, as sometimes occurs with the cam brake, the only certain relief is to be found in the release of the same, provided the locking is due to the application of the brakes alone unassisted by the reversal of the engine. It may be possible to start by throwing the reverse lever into full gear forward and suddenly opening the throttle. This, however, is of doubtful efficiency and cannot be depended upon.

*Q. In case a driving axle becomes hot, what is the best position in which to place the engine in order to repack the same?*

A. For packing the axles of trailing wheels, there is little or no choice of position as far as the cranks are concerned. In the case of the main driving axle it is usually advantageous to stop the engine so that the eccentrics are as much out of the way as possible. Ordinarily it will be found that with the crank one-eighth of a turn below the forward center, these parts will be as much out of the way as it will be possible to get them.

*Q. Why is it necessary when keying rod brasses to make sure that the engine is in tram before doing the work?*

A. Because of the necessity that the lengths of the rods should correspond to the distance between the centers of the wheels that are coupled and because of the impossibility of drawing the wheels into tram by keying the rod brasses. A

fundamental rule for this piece of work is never to attempt to key rod brasses with the engine out of tram. The reason for this is that, if the engine is out of tram, the rods upon the two sides of the engine will be of different lengths and there will be a constant strain set up that will not only prevent the smooth working of the engine but may result in a breakdown. Thus, if the main axle does not stand square with the frames when the main rod is keyed the result will be either that the wheels will have a constant tendency to crowd against one rail producing a sharp flange upon the wheel that is set back; or if the axle does afterward become square with the frames, the inequality in the length of the main rods will carry at least one piston nearer to one cylinder head than the other, which in exaggerated cases may cause a pound that will be decidedly detrimental to the safety of the machine.

In case the wheels connected by side rods are not upon parallel axles, there will be the same tendency for one wheel to crowd the rail and wear a sharp flange. In addition to this the box will be held out of line with the shoes and wedges and be apt to stick, or, at any rate, wear more rapidly than would otherwise be the case. Too great pains cannot be taken when keying and fitting rod brasses to see to it that the axles are parallel to each other and square with the frames. Then, by leaving the brasses so loose that they can be easily whirled and moved to and fro on the pin, the best and most satisfactory results will be obtained.

## CHAPTER XIV.

### Accidents to Compound Locomotives.

*Q. What must be done in case of an accident to a compound locomotive?*

A. If the compound locomotive is of the two-cylinder type, and the accident occurs to any of the parts that are common to it and the simple engine, the emergency may be dealt with in the same way as with the simple engine. The same holds true of the four-cylinder cross compound type. In the case of the four-cylinder engine of the Vaucrain type, it may be necessary to vary the method somewhat in the case of the valves and pistons. For all parts of the mechanism outside the cylinders and beyond the crosshead and rocker the instructions given for the simple engine will hold.

*Q. What special parts of two-cylinder compound locomotives are apt to get out of order or be broken?*

A. The intercepting valve and the receiver in the smoke-box.

*Q. What accidents can occur with the intercepting valve of what is known as the Richmond compound locomotive?*

A. This valve is shown in section in Fig. 66, in the position which it occupies when working under compound conditions. It may stick in the open position as shown or in the closed position with the valve *I* against its seat *K*. The emergency valve *E* may also be stuck open or closed. Or some one of the parts named may be broken.

*Q. What will be the result if the intercepting valve sticks open in the position shown in Fig. 66.*

A. The fact will not be apparent so long as the engine is in motion, since that is the position the valve should occupy while working as a compound. When a stop is made,

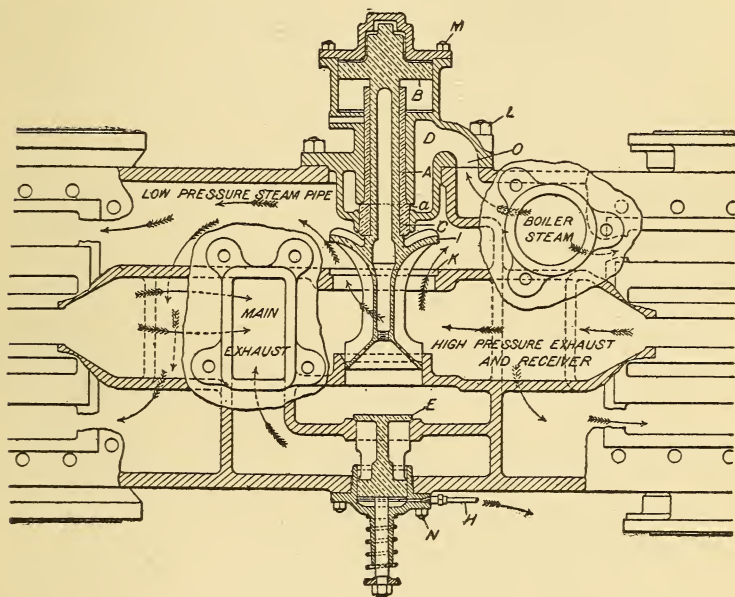

FIG. 66.—SECTION OF INTERCEPTING VALVE OF THE RICHMOND TWO-CYLINDER COMPOUND LOCOMOTIVE.

however, the engine will be found to be in the same condition as a simple engine that has been disconnected upon one side and is to be worked with a single cylinder. It will then be found to be impossible to start the engine if the high-pressure crank is at or near the center. If, however, the engine is standing so that the high-pressure cylinder

can start it, the engine will move and the first exhaust from that cylinder will put some pressure on the large pistons; probably enough to keep the light machine in motion but not enough to start a heavy train.

*Q. What will be the result if the intercepting valve sticks closed against its seat K?*

A. This is a more serious matter. When the valve is so closed, the engine is supposedly working as a simple engine, and this is the case only when starting and exerting a maximum tractive power at a slow speed, as the valve is only closed at such times and it is almost impossible that it should occur when the engine is running at speed upon the road.

If the engine were to be running slowly and working as a simple machine, the emergency valve *E* would be raised from its seat and there would be nothing to indicate to the engineer that anything was the matter with the intercepting valve. When it became desirable to convert the engine to compound action, or after starting in the ordinary manner when it is automatically converted to such action, the trouble would at once manifest itself. The pressure in the receiver would rise until it equaled that of the boiler, and the pressure upon the two sides of the high-pressure piston would be equalized and it would cease to be doing any work.

The relief for this state of affairs is to open the emergency valve *E*, permitting the exhaust from the high-pressure cylinder to escape into the atmosphere, thus reducing the back pressure upon its piston and making it possible to run slowly in simple action.

*Q. What will be the result if the emergency valve E sticks shut?*

A. The only result will be that it will be impossible to convert the engine to simple action. It will start in simple action and then, as soon as the receiver pressure has risen to the proper point, it will automatically change to compound action. For such a condition as this nothing need be done until the trip is ended.

*Q. What will be the result if the emergency valve E sticks in the open position?*

A. This will render it impossible for the engineer to convert the engine to compound action and the engine will continue to work as a simple expansion machine so long as it remains open. Such a condition will involve running slowly to the first stopping place, when the valve may be closed.

*Q. What is the objection to running fast when the valves are in the position indicated in the previous question?*

A. There is no objection and no danger in running rapidly under these circumstances, but the construction of the engine is such and the exhaust passages from the high pressure cylinder are so restricted that it is impossible for the engine to attain or maintain a speed of more than from eight to ten miles an hour under these conditions.

*Q. If the main valve I of the Richmond intercepting valve should be broken, what would be the result?*

A. The result would be the same as though it were stuck open as detailed in answer to the second question preceding, as far as the delivery of the high-pressure exhaust to the low-

pressure cylinder is concerned. That is to say, this exhaust steam would be able to pass directly from the receiver to the steam chest of the low-pressure cylinder.

In addition to this, it might be possible for live steam to flow from the auxiliary steam pipe to the low-pressure steam chest, provided the break was of such a nature as to render the reducing sleeve inoperative. This might produce an excess pressure in the low-pressure cylinder. If this sleeve was still operative, the effect would be to shut off the live steam from the auxiliary pipe and allow the engine to work as a compound.

*Q. When an intercepting valve on a Richmond compound locomotive is out of order, how can it be repaired or readjusted?*

A. If it is desired to examine the piston and emergency valve access can be obtained to the same by taking off the cap held by the nuts *N*. If the dash pot plunger *B* is to be examined it may be done by removing the cap held by the nuts *M*. In order to remove the whole valve, take off the cap held by the nuts *L* and everything can be removed from the casing.

*Q. If the intercepting valve of a Richmond compound locomotive is so broken that the flow of steam from the auxiliary steam pipe to the low-pressure cylinder is such that an excessive pressure is apt to be created in that cylinder, what should be done?*

A. No injury can ordinarily result from this condition, as the low-pressure steam chest is provided with a safety valve for the relief of any such excess of pressure.



*Q. What should be done in case the intercepting valve of a Richmond compound locomotive should become broken in such a way that the reducing valve portion is so fractured as to allow live steam from the boiler to blow unchecked into the receiver?*

*A.* The cap held by the nuts *L* should be removed and all of the parts of the intercepting valve removed with the exception of the emergency valve *E*. A piece of wood should then be put over the opening *O* leading from the auxiliary steam pipe, thus cutting off the flow of steam to the intercepting valve casing. This board should also be made to cover the opening of the casing.

The result of this arrangement will be to convert the engine into a purely compound engine, with free passages from the high-pressure exhaust to the low-pressure steam chest. When running, the engine will act as in ordinary working, but, at starting, only the high-pressure cylinder will be available.

*Q. If the breakage should be such that the emergency valve *E* is destroyed in addition to the fractures, as detailed in the previous question, what should be done?*

*A.* When taking out the other parts of the intercepting valve the emergency valve *E* should be removed also.

Two courses are now possible. The openings at *O* and that of the valve itself may be closed as described in the answer to the previous question. Under these conditions the exhaust from the high-pressure cylinder would pass directly out to the atmosphere, and that cylinder would alone be avail-

able for work. It would also involve the desirability, if not the necessity, of disconnecting the low-pressure side.

The other and better course will be to place a piece of board over the seat of the emergency valve *E*, and hold it in position by a bolt passing through it and out through the hole in the cap usually filled by the stem of the emergency valve.

This will put the engine in exactly the same condition as

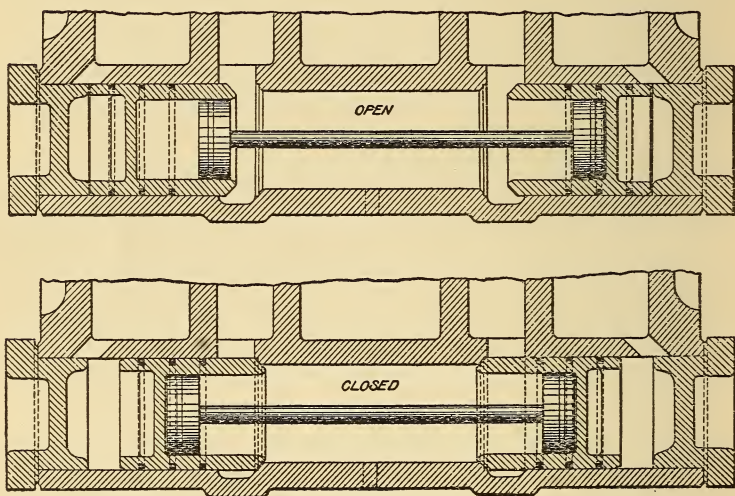

FIG. 67.—SECTION OF BY-PASS VALVE OF RICHMOND COMPOUND LOCOMOTIVE IN OPEN AND CLOSED POSITION.

that described in the answer on page 176, with the emergency valve in good condition and held against its seat.

*Q.* What will be the effect upon the working of the Richmond compound locomotive if the by-pass valves of the low-pressure cylinder are stuck open, and what should be done?

A. As the function of these valves is, when open, to permit the passage of air to and fro from one end of the cylinder to the other, when the engine is in motion with the steam cut off, it follows that if they are stuck open as in Fig. 67, steam entering one end of the cylinder will have access to the other also, with the result that its effect upon the piston will be nullified. It amounts to the practical cutting out of the low-pressure cylinder to which they are applied.

The remedy is to remove the caps from the ends of the by-pass valve casing and drive the valves back into their closed position; blocking them there if necessary.

*Q. What will be the effect if the by-pass valves of a Richmond compound locomotive are stuck shut and what should be done?*

A. As this is the proper position of these valves when the engine is at work, nothing will be noticed while this condition prevails. As soon as steam is shut off, however, air will be drawn into the low-pressure cylinder through the relief valve and pumped out at the exhaust, thus constantly fanning the fire.

Since this is not a serious matter and can be partially neutralized by opening the furnace door, it will not be worth while to stop the train to readjust the valves, and this sticking can be neglected until the end of the run is reached.

*Q. What can be done to render the low-pressure cylinder available for useful work if the by-pass valve should become broken, leaving the passage between the ends of the cylinder open?*

A. It is merely necessary to remove the broken parts and

drive a wooden plug into the middle of the valve, as shown in Fig. 68, where it may be held by a plug or nail driven in at the vent hole in the middle of the casing at the bottom.

*Q. What will be the result and what should be done if the receiver of a two-cylinder compound locomotive is broken or ruptured?*

*A.* If the fracture is not of sufficient size to cause a serious fall in the receiver pressure, the engine may be run in that condition to the end of the trip, though the leaking of

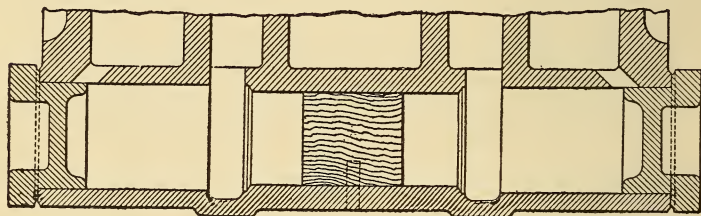

FIG. 68.—PLUGGED BY-PASS VALVE OF RICHMOND COMPOUND LOCOMOTIVE.

steam into the smokebox may seriously interfere with the steaming of the boiler.

If the break is of such a character as to so reduce the receiver pressure that the low-pressure cylinder does not receive a sufficient supply of steam to maintain the proper steam chest pressure, the automatic intercepting valves of such designs as the Richmond and Schenectady will close and live steam from the boiler will be delivered at a reduced pressure to the large cylinder.

Under these circumstances the emergency valve should be opened so as to permit the exhaust steam from the high-

pressure cylinder to pass directly into the atmosphere. The engine can then be run in simple action to the terminal.

*Q. What should be done if the auxiliary steam pipe leading to the low-pressure cylinder should become broken?*

A. This accident will have no effect whatever upon the action of the engine when in compound action, as no steam passes through this pipe to the cylinder under these conditions.

The treatment of the matter will depend upon the nature of the break. If it merely causes a leak that does not seriously interfere with the steaming of the engine or the maintenance of the pressure, it may be ignored until the end of the run is reached.

If it does cause so great an escape of steam as to prevent the maintenance of the proper pressure, a plate of metal should be put in between its flange and that of the tee head, to prevent this loss, exactly as described in regard to the steam pipes of a simple engine in the answer to the question on page 128.

*Q. What leaks are likely to occur in the intercepting valve of a Richmond compound locomotive?*

A. This intercepting valve, which is shown in section in Fig. 66, may develop a leak at *a* or along the outside of the sleeve *C*. A leak past the seat *a* of the reducing sleeve, merely allows the steam to flow down the outside of that sleeve and escape into the atmosphere at the front of the cylinder saddle. It does not affect the working of the engine nor cause a blow, and is at once detected by the appearance of the escaping steam at the point indicated.

A leak along the outside of the sleeve *C* permits live steam to flow from the chamber *D* into the receiver. Such a leak has a tendency to raise the receiver pressure and thus increase the work of the low-pressure while it lowers that of the high-pressure cylinder. There is but little chance or probability that this leak will become a serious matter in the operation of the locomotive, and it can ordinarily be neglected.

If, however, it is desired to determine definitely whether or no there is a leak at this point, the test may be made as follows:

First make sure that there is no leak at the high-pressure valve. Remove the cap of the emergency valve *E* and with the latter block the intercepting valve into the open or compound position which it occupies in Fig. 66. Place the high-pressure valve in the central position and open the throttle slightly. If there is a leak steam will appear in the receiver and escape at the cylinder cocks of the low-pressure cylinder.

Such a leak will be very insignificant at the worst, and its detection and location will not repay the labor involved if it is to be done upon the road.

*Q.* *What accidents may occur with the intercepting valve of what is known as the Schenectady compound locomotive?*

*A.* The breakage of the various parts forming this valve, or the sticking of those that should move from one position to another, in addition to the breakage of the receiver and auxiliary steam pipe that are common to all two-cylinder compound locomotives.

*Q. What will be the result if the intercepting valve of a Schenectady compound should become stuck in the closed position, shown in Fig. 69, and what should be done?*

A. When in this position the engine is in simple action and the pressure in the receiver from the exhaust of the small cylinder would accumulate until its back pressure neutralized the steam pressure on the working side of the high-pressure piston.

The remedy would be to open the emergency or starting valve in the cab and thus admit steam back of the piston *A*, moving it to the left as in Fig. 69, and thus opening the valve *B*, through which the exhaust from the high-pressure cylinder will be permitted to escape from the receiver into the atmosphere.

While in this condition the operation of the engine will be confined to simple action, and in that way may be made to haul its train to destination.

*Q. How will the sticking of an intercepting valve of a two-cylinder compound locomotive in the closed condition manifest itself?*

A. By the sluggish action of the engine, due to the fact that all of the work is being done by the low-pressure cylinder.

*Q. What will be the result if the intercepting valve of a Schenectady compound locomotive should become stuck in the open position?*

A. This is the position, shown in Fig. 70, in which the engine is in compound action. The result will not be noticeable when the engine is working regularly. But at starting

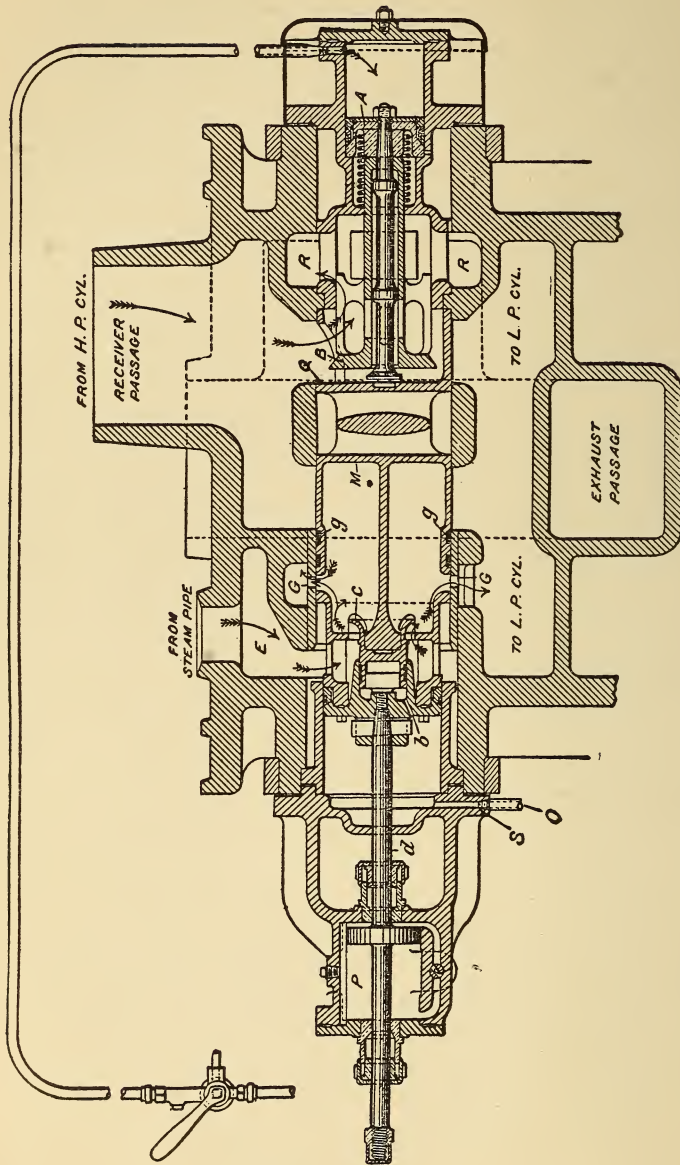

FIG. 69.—INTERCEPTING VALVE OF THE SCHENECTADY COMPOUND LOCOMOTIVE WHEN WORKING AS A SIMPLE ENGINE.



no steam would be admitted from the auxiliary steam pipe to the low-pressure cylinder, with the result that the engine could not be put into simple action and the small cylinder would alone be available for the work. It would be the same as though the low-pressure side were disconnected until an exhaust from the small cylinder had developed some pressure in the receiver, which is at once communicated to the large piston.

*Q. What will be the result and what should be done if the shell M of the intercepting valve should be broken?*

A. The results and the remedy will both depend upon the extent and nature of the injury.

If the forward part of the shell only, or that in front of the reducing valve *c*, is broken, the remaining portion may be pushed ahead into the position that it would naturally occupy when the engine is in simple action.

When so placed the automatic reducing valve *c* will shut off the flow of live steam from the auxiliary steam pipe to the low-pressure cylinder or at least regulate the pressure. The locomotive can then be run as a compound without trouble. At starting the reducing valve will act the same as usual, but will blow steam into the receiver as well as the low-pressure steam chest, thus lowering the power of the high-pressure cylinder.

If the injury extends back so that the reducing valve is put out of action, it will be possible for the live steam from the auxiliary pipe to blow directly through to the receiver and low-pressure steam chest. This would put full boiler pressure upon the large piston, so increasing the power of

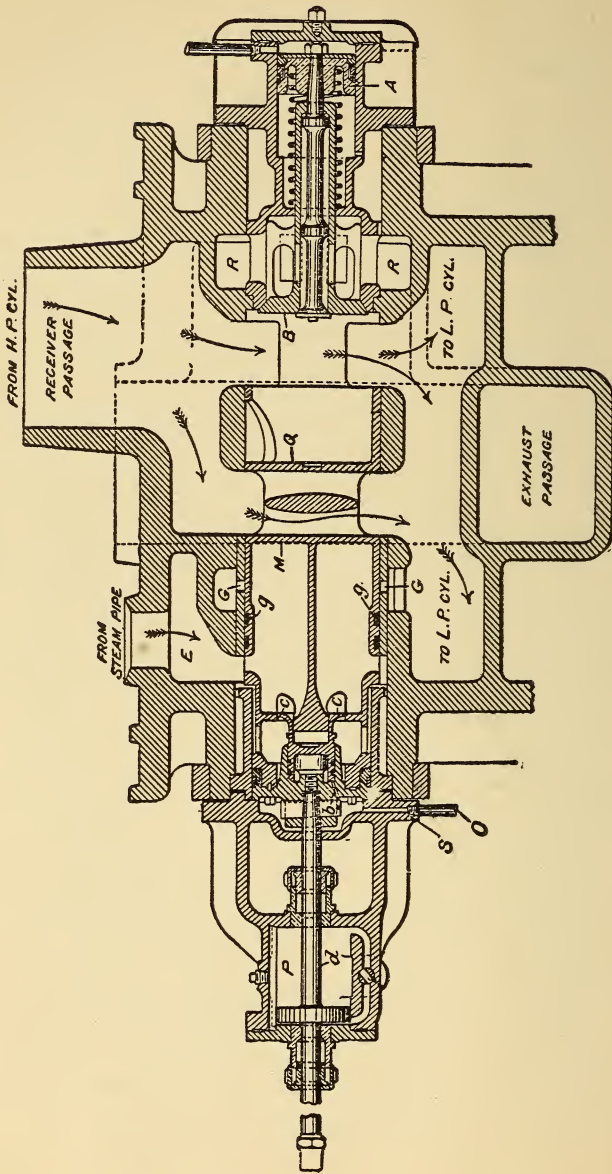

FIG. 70.—INTERCEPTING VALVE OF THE SCHENECTADY COMPOUND LOCOMOTIVE IN POSITION FOR WORKING AS A COMPOUND.

the same that the handling of the engine would be exceedingly difficult on account of the slipping of the wheels, were it not for the safety valves on the low-pressure cylinder which would be blowing off steam to their full capacity.

This flow of steam should be stopped. It can be done by taking off the cap of the intercepting valve case at *S* and, after removing all of the broken parts, a wooden plug can be driven in to cover the openings from the chamber *E* of the auxiliary pipe to the intercepting valve chamber. Then, by replacing the cap at *S*, the engine may be worked as a compound.

*Q.* *What will be the result and what should be done if the stem *d* connecting the intercepting valve and the piston of the dashpot *P* should become disconnected or broken?*

*A.* This accident will manifest itself by a violent slamming of the intercepting valve when the engine is changed from simple to compound action or the reverse.

If running it is well to keep the throttle open so as to hold the valve in one position as far as possible. At the first stop the cap of the valve casing should be removed at *S*, and an examination made of the fracture. If the key only has come out or been broken it may be put back or replaced with another. If the rod is broken the intercepting valve itself may be put in either the simple or compound positions as in Figs. 69 or 70. If in the former it may be held closed by putting a block of wood between the back end of the valve and the inside of the cap and bolting the cap home.

Steam should then be admitted against the piston *A* so as

to hold the valve *B* open and thus give the high-pressure exhaust a free passage to the atmosphere.

If the valve is to be put in the position of compound action, as shown in Fig. 70, it may be tied there by means of a piece of bell cord passed through the opening of the dashpot stem *d* which should therefore be removed.

The first of these methods will probably be the most satisfactory way of getting over the road with a heavy train where grades must be climbed, the second where the train is light and speed is of more importance than the development of a high tractive power.

*Q. Where is it possible for leaks to occur and what are apt to be the results in the case of the intercepting valve of the Schenectady two-cylinder compound locomotives?*

*A.* This valve is shown in section in Figs. 69 and 70. A leak may exist between the valve *B* and its seat, allowing steam to escape from the receiver into the direct exhaust. This lowers the receiver pressure, tending to decrease the work of the low-pressure cylinder and increase that of the high. The leak, however, is not apt to be serious, and will, therefore, have an inappreciable effect upon the working of the engine.

A second point of leakage will be around the main shell of the intercepting valve. This will have no influence whatever except when the direct exhaust valve *B* is open and the engine is working simple. In that case there may be some back leakage from the low-pressure steam passage into the exhaust.

It is quite possible, if this leak were large enough, for it

to produce a continuous blow, which would only be audible when the engine were working as a simple machine.

A third possible point of leakage is at the packing rings *g*. When the engine is working as a compound such a leak would permit a flow of live steam to take place into the low-pressure steam chest, but would not cause a blow. When the engine is working as a simple machine such a blow may permit steam to escape into the receiver and thence into the atmosphere. It might be serious enough to produce a continuous blow, but such a condition is highly improbable.

The fourth possible point of leakage is past the packing rings of the working piston *b*. Such a leak allows steam to escape to the atmosphere through the small pipe *O*, thereby making itself at once manifest.

None of these leaks are apt to be at all serious, so that little or no attention need be paid to them until the engine can be sent to the shop for repairs.

In fact, the wear of the intercepting valves of two-cylinder compound locomotives is not apt to be of a character that will materially affect the action or working of the machine in a way that will be perceptible upon the road.

*Q. What will be the result and what should be done if the emergency valve B of a Schenectady compound locomotive becomes broken or stuck open?*

*A.* This permits of a direct passage of the high-pressure exhaust into the atmosphere, so that the engine must be worked in simple action. If the remaining portion of the intercepting valve is intact and operative, it will move into

the position shown in Fig. 69, and live steam will be admitted to the low-pressure cylinder through the reducing valve. The engine can thus be run to destination as a single expansion engine.

If it is desired to work it as a compound when the valve *B* is broken it will be necessary to remove the cap of the chamber in front of the piston *A*, and remove the latter. A plug may then be driven in to close the passage *R* leading to the exhaust pipe.

Whether it will be worth while to do this or not will depend upon the distance to be traveled and the time available.

*Q. If one side of a two-cylinder compound locomotive is disabled in any way so that it must be disconnected, can the engine still be worked on one side?*

A. Yes.

*Q. If the low-pressure side of a two-cylinder compound locomotive is disabled so that it must be disconnected, what should be done?*

A. The rods, valve, crosshead, and other parts relating to the cylinder should be treated in exactly the same way as in the case of a simple engine. (See pages 18 and 20.)

When this has been done the emergency valve should be opened so as to permit the exhaust steam from the high-pressure cylinder to escape into the atmosphere. The intercepting valve will then move into the position of simple action and the low-pressure steam chest will be filled at a pressure corresponding to that at which the reducing valve is set to act; just as, under the same circumstances, the

steam chest of the disabled side of a simple engine is subjected to boiler pressure in consequence of the steam delivered to it from the open pipe.

*Q. If the high-pressure side of a two-cylinder compound locomotive is disabled so that it must be disconnected, what should be done?*

A. This accident may be treated in exactly the same manner as though it had happened to one of the parts of a simple engine, and the rods, valve, and crosshead should be blocked in the same way. (Pages 18 and 20.)

If the throttle valve is opened after this blocking and disconnecting has been done, the intercepting valve will automatically move its starting position and the reducing valve will open so as to admit steam to the low-pressure steam chest. The engine will then start and run with the low-pressure piston at work alone. It will not be necessary to open the emergency valve, as required in the answer to the previous question, because there will be no steam in the receiver and nothing coming from the high-pressure cylinder that needs to be taken care of.

*Q. What blows are apt to occur with the two-cylinder compound locomotives of the Richmond or Schenectady types?*

A. Blows in these engines may be the result of leaky valves, pistons, and intercepting valves.

*Q. What will be the effect of leaky piston rings in two-cylinder compound locomotives, and how can they be detected and located?*

A. Leaky rings in the high-pressure piston permits the

live or working steam to pass through to the exhaust side of the piston and thence to the receiver and low-pressure steam chest.

The result is to increase the work done by the low-pressure piston and decrease that of the high-pressure. The leak may be detected in the same way as that described for simple engines, namely, by the noise it makes and by admitting steam to one end of the cylinder and opening the cylinder cock at the other.

A leak in the piston rings of the low-pressure cylinder can be detected and located in the same way as in the case of simple engines. (Page 17.)

*Q. What will be the effect of leaky valves in two-cylinder compound locomotives, and how can they be detected and located?*

A. A leaky high-pressure valve permitting a blow through to the exhaust passage will tend to lower the amount of work done by the high-pressure cylinder and increase that of the low-pressure. It can be located in the same way as in the case of simple engines. (Page 15.)

A blow through the valve of the low-pressure cylinder manifests itself in the same way and can be detected and located by the same means as that set forth for a similar work on a simple engine in the answer on page 15.

*Q.—In case of a breakage of the working parts upon one side of a Vauclain four-cylinder compound locomotive, what can be done?*

A. This engine consists of two separate and distinct compound locomotives, just as an ordinary locomotive consists



of two simple machines. Hence an accident to one side permits the other to be worked without reference to the first. It only remains to disconnect and block the disabled side and proceed as with the simple engine.

*Q. If an accident should disable one of the cylinders of a Vauclain compound locomotive, would it be possible to use its mate under steam?*

A. It would be possible but not advisable.

By removing the piston and covering the opening for the rod, steam could blow through the small cylinder and be used in the large, or the exhaust from the small can be made to blow through the large to the nozzle. But, owing to the construction of the crosshead and the desirability of maintaining an approximately even balance in the pressure applied to the top and bottom of the same, the piston rod of the single cylinder, worked in the way suggested, would be apt to be broken and the resultant damage to the working cylinder wreck the engine.

*Q. What will be the result and what should be done in case the equalizing valve of a Vauclain compound locomotive should be broken?*

A. The result will depend somewhat upon the nature of the break. If it is such that the steam is given a clear passage through it, the engine will be put in the starting condition and the high-pressure piston will be equalized while the low-pressure will be working under full boiler pressure less the losses due to wire-drawing. In this case the excess of work is being done by the large piston and there is

the same danger of piston rod breakage as that given in the answer to the previous question.

If the valve is simply broken off in a way that allows the steam to blow out, the remedy will be to plug the holes of the pipes and so brace the plugs in place that they cannot be blown out by the steam behind them. This remedy enables the engine to run regularly in compound action, but destroys its extra tractive power when starting.

*Q. What are the causes of the principal blows that may occur on a Vauclain compound locomotive?*

A. Leaky packing in the cylinders and valves and the leakage of the starting valve.

*Q. If the starting valve of the Vauclain compound locomotive leaks what will be the effect?*

A. This leak will permit live steam to enter the low-pressure cylinder, and manifest itself by causing an inequality in the exhaust; that from the side upon which the leak exists being the stronger.

*Q. How can a leak in the starting valve of a Vauclain compound locomotive be detected?*

A. As already stated in answer to the previous question, a leak in one of the starting valves will cause an irregularity in the exhaust. If, then, the starting valves be opened or placed in compound running position live steam will be admitted to both low-pressure cylinders, and the inequality in the exhaust will disappear.

Should there be a leakage to the same extent through both valves, then there would be no inequality in the exhaust. This is, however, a very improbable state of affairs.

*Q. Is there no other defect that may cause an inequality in the exhaust of the Vaucrain compound locomotive, and if so how is it caused and how can it be detected?*

A. If the test applied according to the answer to the previous question does not make the exhaust even for the two sides of the engine, the trouble may be found in the packing of the valve.

With a leaky starting valve each alternate exhaust is heavy, the intermediate ones being light. If one of the packings of the valve for high-pressure steam leaks it will permit steam to pass continuously into the low-pressure cylinder, first into one end and then into the other, causing one heavy exhaust to alternate with a light one.

This condition can be very readily detected in distinction from the blow due to a leaky starting valve; from the fact that the opening and closing of the latter has no effect in stopping the inequality or lameness.

Still another cause of lame or unequal exhaust is to be found in leaky piston rings in the high-pressure cylinders. When this is the case the live steam pressing against one side of the high-pressure piston passes through to the exhaust side, and thence direct to the working side of the low-pressure piston. In this way the exhaust pressure in the large cylinder is raised with the result that there will be a heavier exhaust upon that side of the engine than upon the other.

*Q. What may cause a continuous blow in a Vaucrain compound locomotive?*

A. If the packing rings between the admission port of

the valve, where the steam enters the interior from the high-pressure cylinder, and the exhaust cavity leaks, there will be a continuous blow out at the exhaust pipe. This is due to the fact that these packing rings are always subjected to either the live steam or exhaust pressures of high-pressure cylinders, and are the only means of preventing a flow of that steam direct into the final exhaust passage of the low-pressure cylinder. If both of these packings leak the blow will be continuous without much, if any, variation in the sound. If only one is defective, the blow will still be continuous but will have periods of rising and falling, dependent upon the position of the valve in its throw. This rise and fall will, however, be exceedingly difficult to detect in the practical operation of the locomotive on account of the other noises that invariably exist.

*Q. How can the blow of the steam through the valves and piston packing be located on a Vaucrain compound locomotive?*

A. The engine should be first placed upon the quarter with the starting valve closed and the wheels blocked. The throttle may then be opened slightly, admitting steam to the high-pressure cylinder; at the same time the reverse lever should be moved forward and back two or three times, thus admitting steam to both faces of the high-pressure piston. Then, with the reverse lever in the back notch, open the forward cylinder cock of the low-pressure cylinder if the crank stands upon the lower quarter and the back cylinder cock if it stands upon the upper quarter. There will be a squirt of steam, but if this issues in any quantity it shows that

there is a leak either at the packing rings of the low-pressure piston or at the rings of the valve, 1 or 4 of Fig. 71.

Whether the leak is in the one or the other of these two places can be determined by moving the reverse lever until the valve is in the central position and covering both ports. If, under these conditions, steam still continues to blow from the cock, it shows that the leak is in the valve packing. If the blow ceases the leak is at the low-pressure piston rings.

A blow through the packing rings of the high-pressure

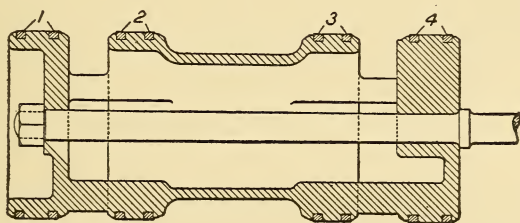

FIG. 71.—LONGITUDINAL SECTION OF VALVE OF VAUCLAIN COMPOUND LOCOMOTIVE.

piston can be located by placing the engine on the quarter as before and opening the back cylinder cock of the low-pressure cylinder if the crank is on the lower quarter and the front one if it is on the upper quarter. There is, then, a clear passage from the exhaust side of the high-pressure piston to the cylinder cock that has been opened. If there is a blow, it indicates that there is a leak at the high-pressure piston.

Before making this latter test, however, it must be first

ascertained that the packing rings, 1 and 4, of the valve (Fig. 71), as well as the starting valve, are tight, for should there be a leak at either of these two points there will be a blow at the cylinder cock.

A leak in the low-pressure rings 2 and 3 of the valve, Fig. 71, is shown by a continuous blow at the exhaust. It will be seen from the illustration, Fig. 71, that if there is a leak at 2 or 3 steam passing from the high to the low-pressure cylinder can leak out into the final exhaust passage. As there will be no such flow of steam when the engine is standing blocked in the position indicated, the starting valve should be opened. This admits steam to the working side of the low-pressure piston, and, backing into the high-pressure cylinder, can leak past the rings at 2 and 3 (Fig. 71) if they are in such a condition as to permit it to do so.

*Q. How should breakages to valves, pistons, crossheads, and other working parts of four-cylinder cross compound locomotives be treated?*

A. As these locomotives consist of practically four distinct engines, each one can be treated as a separate unit. If an accident happens to the working parts of any one of these units, it may be taken down and disconnected as in the case of a two-cylinder simple engine, if each cylinder, both high and low-pressure, is provided with its own valve motion. Where one valve is made to serve two cylinders it may be necessary to disconnect the pair, if an accident happens to one of them.

*Q. How should a Baldwin four-cylinder cross com-*

*pound locomotive be treated in case of an accident to the valve of one pair of cylinders?*

A. In this engine the high-pressure cylinders are between the frame and the low-pressure upon the outside. The valve is of the piston type and is placed above and between them. As this valve is so designed that it serves two cylinders, it is evident that any accident to it will disable both. It will, therefore, be necessary to treat both cylinders and all of their connections and working parts in exactly the same way as that detailed for the single cylinder of a simple engine when a valve is subjected to a similar mishap.

*Q. If in a Baldwin four-cylinder cross compound locomotive an accident happens to a piston, crosshead, or connecting rod, will it be possible to disconnect and block for the cylinder to which the broken part belongs, and, at the same time, leave the valve and its motion intact, so as to retain the working power of the other cylinders?*

A. Such a course would be inadvisable. No matter how tightly the blocking may be put in position, the rapidly recurring thrusts of the piston, under the influence of the steam admitted to it by the motion of the valve, would be apt to loosen it, and if it did give way the cylinder would be wrecked. The safe course is to disconnect and block the parts of both cylinders and run no risks.

*Q. What should be done in case of an accident to the valve of a four-cylinder tandem compound locomotive?*

A. As time is always an important element in applying the remedy to any accident upon the road an accident to the

valve of a pair of tandem cylinders should be treated as an accident to the valve upon one side of a simple engine, whether there is a single valve to serve the two or a separate valve for each.

*Q. What should be done in the case of the breakage of a piston of a tandem compound locomotive?*

*A.* In these engines the high-pressure cylinder is usually at the front, so that any accident to the low-pressure piston will ordinarily involve the loss of so much time in the removal of the same that the best and most expeditious method of making repairs will be to clamp the valve in the central position and block the crosshead exactly as in the case of a simple engine. If it is the high-pressure piston that has suffered the accident, it may be possible to remove the broken parts and proceed. This, however, will involve the admission of steam at boiler pressure to the low-pressure cylinder for all points of the cut-off. For the steam admitted through the high-pressure valve will immediately fill that cylinder and be ready to flow into the low-pressure cylinder as soon as the valve is opened. Such a course should not be attempted unless the broken piston can be so removed from the cylinder that no part remains to bear against the inside of the same, and it has been positively ascertained that the piston-rod is not bent. Otherwise the safe and proper course to pursue will be to clamp the valve in its central position as detailed on page 18 for a simple engine, and block the crosshead as described on page 20, disconnect the main rod and proceed with the engine working steam on one side only.



## CHAPTER XV.

### **Tools and Appliances for Making Engine Repairs.**

*Q. In case it becomes necessary to take down one end of a side or main rod, how can it be conveniently held or handled?*

A. Fig. 72 shows a device that has been designed for this work. It consists of a Z-shaped bar *A*, one leg of which rests on the frame *C*, while the other has a thread cut in it to take the screw *B*. At the upper end of the screw there is a loose cap to carry the rod *D*. The application will be readily understood from the engraving.

Another and simpler tool is shown in Fig. 73. This is formed of a piece of  $\frac{7}{8}$ -inch round steel. It is bent into the form of a crank and sharpened to a chisel edge at one end and a sharp point at the other. The shape is such that, if the short arm rest upon the spokes of a wheel, the end of the rod can be readily raised and lowered. Again, by letting the long arm rest upon the main rod the short section is in a convenient position to carry the side rods of a mogul or consolidation engine. The weight being carried below the point of support, it can be readily adjusted without danger of slipping.

*Q. When it becomes necessary to repack the oil cellars of driving boxes, how can they be removed?*

A. As these cellars are fitted snugly in position, it is frequently necessary to use considerable force to pull them out. A very convenient device for this purpose is shown in

Fig. 74. It consists of a pair of tongs arranged so that, when there is a downward pull upon the chain, the upper

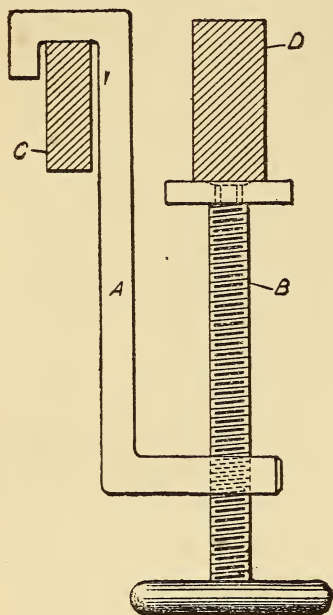

FIG. 72. — BRACKET FOR SUPPORTING SIDE OR MAIN RODS.

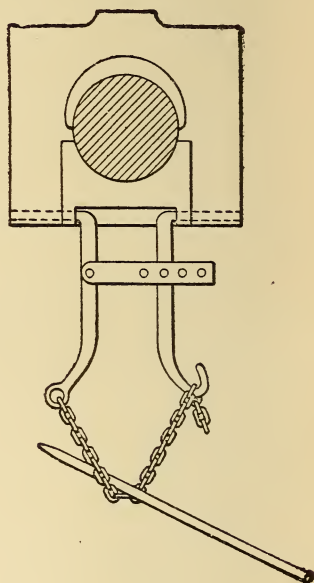

FIG. 74. — TONGS FOR REMOVING OIL BOX CELLARS.

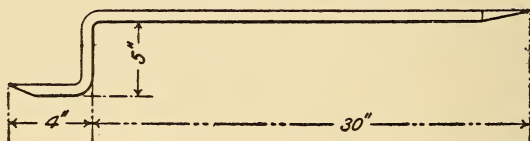

FIG. 73. — LEVER FOR HOLDING SIDE AND MAIN RODS.

ends of the levers are thrust out into the bolt holes of the cellar, thus serving to remove it. The parts may be made

of  $\frac{3}{8}$ -inch by  $\frac{1}{2}$ -inch flat iron with a chain of suitable length to allow a bar to be thrust over it and in between the spokes of the wheel.

*Q. How can a headlight be lighted in a high wind?*

A. It is sometimes impossible to do this work in the ordinary way when the wind is blowing hard. The method of common practice under such conditions is to ignite the wick with the chimney in position and from the top of the same. One means is to wrap a piece of manifold or tissue paper about the finger and fit it down against the wick. In a few minutes it will become saturated with oil and a lighted match dropped in at the top of the chimney will ignite



FIG. 75.—DEVICE FOR LIGHTING HEADLIGHTS.

it, and through it the wick. The objection to this method is that it involves a danger of cracking or smoking the chimney.

Another ready method is to hold the match in a split stick and lower it against the wick from the top of the chimney. This, too, has its objections in that there is some difficulty in holding the match for lighting in this way.

A very handy instrument is shown in Fig. 75. It consists of a tube contracted at one end, having a slotted opening *b* on one side, and in which there is a plunger *f*, that is fitted with a thumb press button and a retracting spring. The match is inserted at the slot and the whole run down

into the chimney from the top. By pressing on the plunger the match is forced out through the contracted end of the tube and ignited as it emerges. The tube holds the match firmly and so makes it possible to easily ignite the wick.

*Q. In making engine repairs, how can bolts that have been put in with a driving fit be started?*

*A.* A common method is to strike them with a sledge through a drift. Sometimes this is impracticable on account of the inaccessibility of the parts to be moved. Under

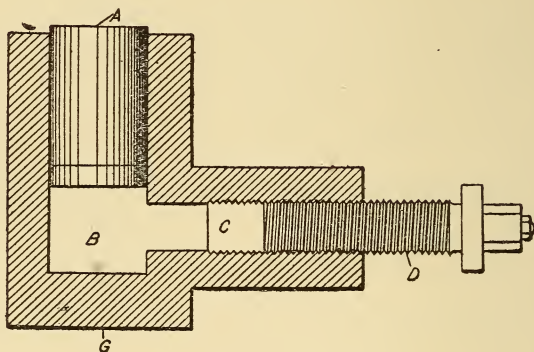

FIG. 76.—HYDRAULIC BOLT STARTER.

these circumstances a small hydraulic press like that shown in Fig. 76 is a convenient tool to use. It consists of a cylinder *B*, into which a plunger *A* provided with a leather packing is fitted. In the branch *C* the screw *D* is made to work in the thread cut on the inside of *C*. The space in the branch and beneath the plunger *A* is filled with tallow. It is evident that when the screw *D* is run in, a heavy pressure can be exerted upon the plunger. This may amount to as much as 60 tons on one of  $2\frac{1}{4}$  inches in diameter. This works on the

same principle as the piston rod starter, shown in Fig. 26, and must be rigidly braced at *G* in order to hold it up to its work.

Another device, shown in Fig. 77, uses gunpowder as a motive power. It can be made of a piece of car axle from 10 inches to 14 inches long, bored out to a diameter of about 2 inches until within 2 inches of one end. A touch hole at the breech and a venthole near the nozzle complete the gun. The projectile is a plug slipping easily into the hole, flat at one end and rounded at the other, where it strikes the blow. With a light charge of powder this plug

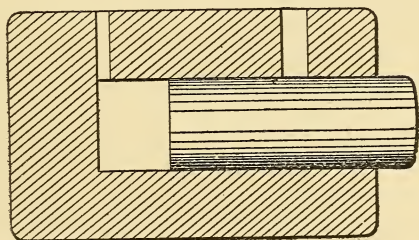

FIG. 77.—CANNON BOLT STARTER.

is blown against the refractory bolt with a force sufficient to start it.

Still another handy tool for doing this same work is the air ram shown in Fig. 78. It consists of a piece of 3-inch gas-pipe plugged at each end and turned off to slide easily in a light cast-iron base. Air is admitted through a half-inch pipe and is controlled by a plug cock. The ram is pushed down to the bottom of the base, as shown in the engraving. The cock is suddenly thrown wide open and the air pressure admitted beneath. This forces out the

plug against the bolt and strikes a strong, sharp blow. This apparatus is easily made and is somewhat safer to use than the cannon, as no explosive is involved and repeated blows can be struck without removing it from its position.

*Q. In using ropes, cords, and chains for effecting temporary repairs upon disabled locomotives, how can these be fastened?*

A. There are a great variety of knots and hitches that

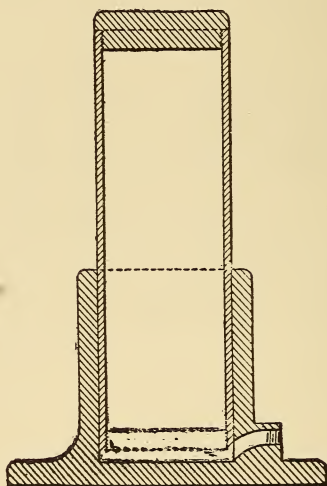

FIG. 78.—AIR RAM FOR REMOVING BOLTS.

can be used for this purpose, a few of which are shown in Fig. 79. The underlying principle of all secure knots is that a part of the tension strands shall bear upon and hold the slack. The most common form of knot is the square or flat knot shown at *A*. In this knot it will be noticed that the ends *a* and *b* lead out on the same side of the loops as the

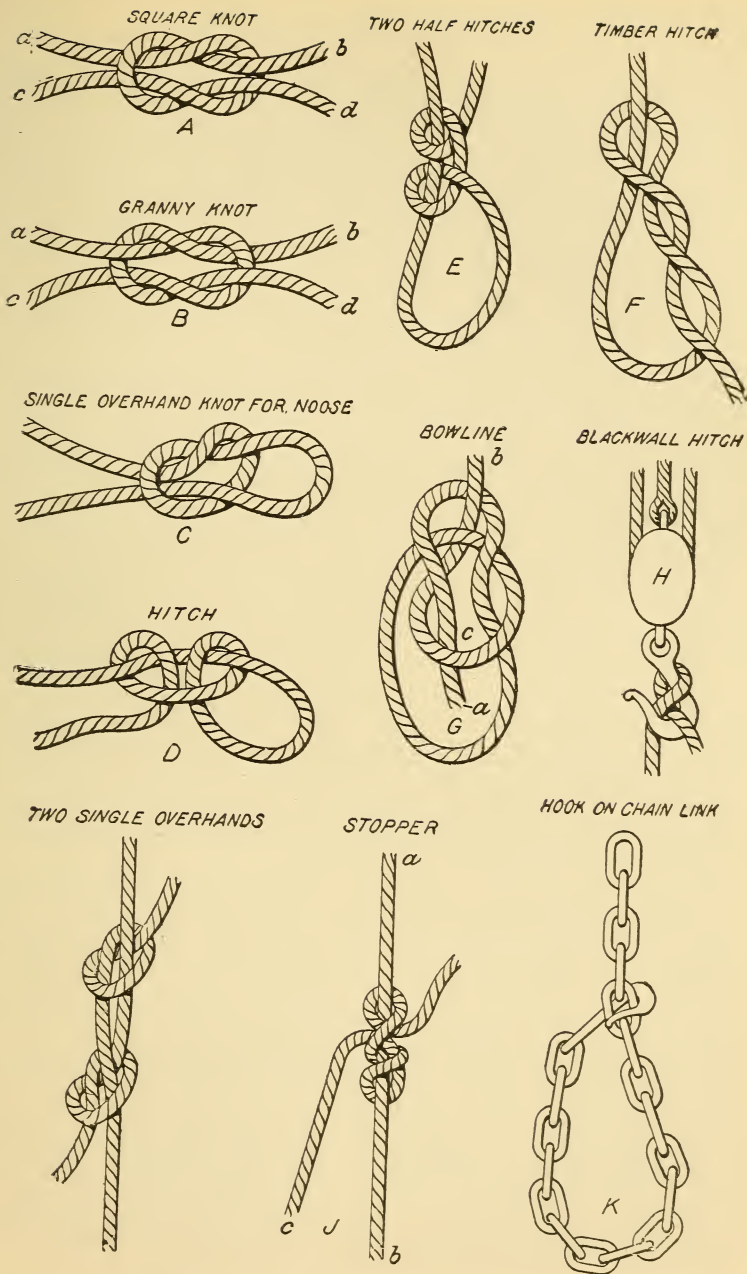

FIG. 79.—COMMON KNOTS AND HITCHES.

standing parts *c* and *d*. A knot of this character will not slip and is readily untied. It so happens, however, that when unskilled hands attempt to tie this knot they frequently make what is known as a "granny" knot, shown at *B*. This is an unsafe knot and is apt to let go and run when a stress is put upon the standing parts. These two knots should be carefully compared and the difference between them noted. This will be seen to lie in the way in which the ends *a* and *b* lead off from the loops. In the square knots they are shown as leading off from the same side of the strand forming the loop as the standing parts *c* and *d*, whereas in the granny knot (*B*) they lead off from opposite sides.

For the formation of a running noose the single overhand *C* is a fairly good knot, though it is sometimes apt to slip. A better one is the hitch *D*, which should not be confused with two half hitches *E*, from which it differs in the same way that the square knot differs from the granny. The timber hitch *F* will also serve for a noose, but should only be depended upon where there is a good surface to bind the slack against the taut part.

To tie a loop that will not slip there is nothing to compare with the bowline shown at *G*. This will not slip no matter how loosely it may be tied, nor will it jam under any stress. It is, therefore, always easily untied. It will be seen that the pull on the standing part *b* binds the free end *a* in the loop *c*.

For fastening a standing or hoisting line to a hook the Blackwall hitch *H* is easily and quickly attached and is secure if properly done. Carelessness in making the turn



will meet quick retribution by the letting go of the line. In addition to the square knot, *A*, which may be used for fastening the ends of separate ropes together, two single overhand knots as shown at *I* may be used. These bind each other tightly and are at the same time readily drawn apart and untied when it is desired to do so.

It is sometimes necessary to make fast to a piece of standing rigging which is already hauled taut and which cannot in any way be used to form a portion of the knot. For this purpose a "stopper" knot is used, as shown in *J*. The standing part *ab* serves as a taut line about which the stopper is tied. The end *c* may then be made fast, and the standing part slackened away at *b*, when the stress will be carried down to *c*, and the standing part then becomes *ac* instead of *ab* as before.

There are, in addition to these, innumerable other knots and splices, but the few here shown will answer for all ordinary requirements.

Splicing can only be learned by practice, and an instructor is almost indispensable.

Chains can be tied in the same manner as ropes, in addition to which a secure fastening can be made by placing a hook over a link as shown at *K*.

It would be well for the engineman to make himself thoroughly familiar with these few simple forms of knots, learning the peculiarities of each, and studying the best means of applying them, so that when an emergency does arise and it becomes necessary to effect a fastening that will be secure in the shortest possible space of time, he may

not find himself in the position of a novice who is unable to tie a knot upon which absolute dependence can be placed.

*Q. How can broken frames be welded without removing them from their position on the engine?*

A. For breaks in engine frames, whether the latter are of wrought-iron or steel castings, the major portion can be welded without removing them from their positions on the engine. This applies to breaks of the frame in the open. That is to say, where it is not in direct or close contact with other parts, as at the cylinders or near the firebox. It will be readily understood that when the break occurs at such points the frame must be removed.

The method of doing the work is the same in principle in the several shops where it is undertaken, though it differs in detail. Oil is used as the heating fuel, and a small portable furnace is used to enclose the part to be repaired.

An exceedingly efficient method that has been used on a large number of frames is to jack the fractured piece apart and slip a piece of iron about  $\frac{3}{4}$  inch thick into the opening so formed. This piece of metal should be laid in with the grain of the metal running in the same direction as that of the frame. It should also be allowed to project about  $\frac{1}{2}$  inch beyond the frame on all four sides. A heavy bolt should then be fastened to the cylinder of the engine and run to a point beyond the break where the weld is to be made, and there made fast.

The enclosing furnace is formed of a sheet metal casing made in halves and lined with firebrick. This is set down

over the frame and bolted together. This furnace is of such a size that, when shut, it leaves a space of about 5 inches between the metal and the firebrick. It is also provided with two peep holes through which the progress of the heating can be watched.

As already stated the heating is done with oil and any one of the good burners upon the market can be used.

When the frame and the filling piece at the place to be welded have been raised to a white heat the oil and air blast are shut off and the casing forming the furnace is knocked apart. The nut on the long bolt, previously referred to, is

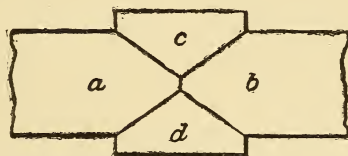

FIG. 80.—DIAGRAM OF FRAME WELD.

then tightened, thus drawing the parts of the weld together, and this is continued until the frame trams 5-16 inch more than the proper normal distance between two points, that should be established before the heating is begun. The projecting portion of the filling piece is then hammered down and the faces of the frame trimmed smooth and flush. When cool the bar will have shrunk back to its original length.

Another method of making the weld is to scarf down the two parts, as shown at *a* and *b* of Fig. 80, and to lay on the two V pieces *c* and *d*, which should be of sufficient size to allow for hammering down.

One of the principal things to be looked to is to see that the furnace can be dropped down out of the way when the heating has been done, and that there is room in which to strike a blow to do the welding. A very convenient tool for doing this work is a pneumatic hammer weighing about 35 pounds. It can be used for breaks in the pedestal and other parts where a ram cannot be worked. The latter, however, should be available for such heavy parts as the

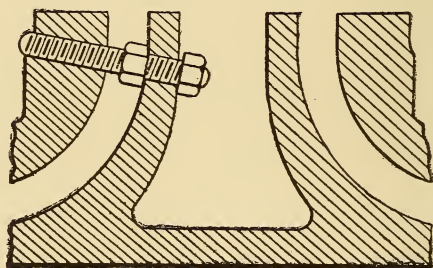

FIG. 81.—METHOD OF STRENGTHENING A CRACKED BRIDGE.

top and front rails. A ram suitable for this work should weigh about 1,000 pounds.

*Q. How can a cracked bridge be strengthened or repaired?*

A. A very satisfactory way that has been used is shown in Fig. 81. It consists in drilling in through the side walls and tapping through them as for a staybolt. Such a bolt is then run through and a nut screwed over it on each side of the cracked partition. These nuts serve to stay the cracked parts, and at the same time act as check nuts to prevent the bolt from turning.

*Q. How can cracked driving wheel hubs be repaired?*

A. There are several ways of strengthening such broken parts. One is to shrink a band about the crank hub, which merely tends to hold the crank and center together, but is not particularly effective in preventing a further development of the crack. This method is shown in Fig. 82.

Another method is to insert a dove-tailed driving piece in the face of the hub just above the crack, as Fig. 83. In

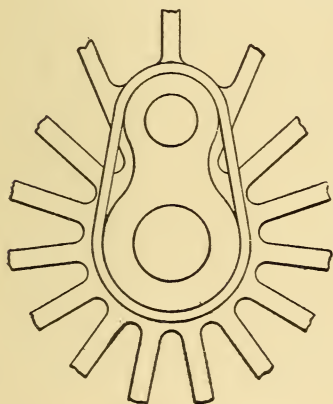

FIG. 82.—BANDED  
CRANK.

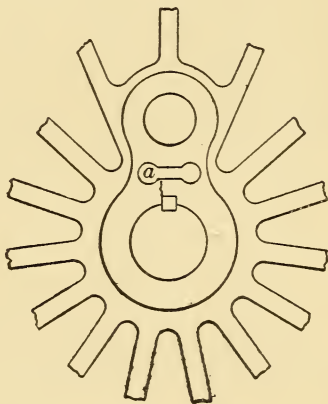

FIG. 83.—STRENGTHENED  
CRANK, WITH DOVE-  
TAILED INSERT.

this the piece *a* is let into the face of the crank just above the crack. The ends may be made 2 inches in diameter and the body connecting them about  $1\frac{1}{4}$  inch. The body should be a trifle longer than the measured distance across the same on the crank when cold and the piece driven in hot. Its contraction will then draw the two sides together, close the crack and prevent its further development. The pocket

for the reception of the piece should be slightly undercut and the piece itself dove-tailed so that there will be no tendency to fall out. This method can also be profitably used in other places about the engine where cracks have started in the cast-iron parts and it is desired to hold them together.

*Q. How can driving wheel tires be tightened without removing them from the center?*

A. A driving wheel tire frequently becomes loose at a distance from the shops where it is of the first importance that it should be tightened without delay. This can be done without removing the wheels or even taking down the main or side rods. The wheel should first be jacked up clear of the rails to a height of three or four inches, if possible, and the wheel guards, if there are any, removed. Pieces of tin or thin sheet iron should then be cut the width of the tire, and from 18 inches to 2 feet in length. These are to be slipped in between the tire and the center. In order that this may be done it will be necessary to expand the tire. To do the latter some heavy pieces of iron or steel should be used. The most convenient thing will be a section of an old driving wheel tire. A heavy slab or a piece of old rail bent to the curvature of the tire may be used. It is well to have four such pieces. They should be heated to a bright red heat and laid on top of the tire and beneath it until the latter has been expanded sufficiently to permit the strips of thin metal to be slipped in between the tire and the center. Of course this work will be greatly simplified where a gasoline tire-heater is available.

## CHAPTER XVI.

### **Air Brake Troubles.**

*Q. What are some of the principal causes of trouble with the air brake apparatus likely to be encountered upon the road?*

A. The failure of the pump, the driver brakes and the tender brake.

*Q. Where are troubles likely to occur in the air brake pump mechanism?*

A. In the air cylinder the valves are not likely to get out of order. The most serious trouble is that due to a breakage of the same. If it is an inlet valve (1), Fig. 84, of the eight-inch Westinghouse pump, the pump will not necessarily be crippled but may continue to work single acting. That is, it will do all of the compressing in one end of the cylinder, while air is merely churned in and out of the other end through the passage left clear by the broken valve.

If a delivery valve (2) breaks practically the same conditions prevail as before, except that compressed air is churned in and out of that end of the cylinder where the break has occurred. The result of both of these conditions will be that the pump will make one quick and one slow stroke, with the difference that in the case of the broken suction valve the quick stroke will be toward the broken valve, while in the case of the disabled delivery valve the quick stroke will be away from it. In each case the pump

will take twice as long to pump up a pressure in the reservoir and train pipe as would be required were it in perfect work-

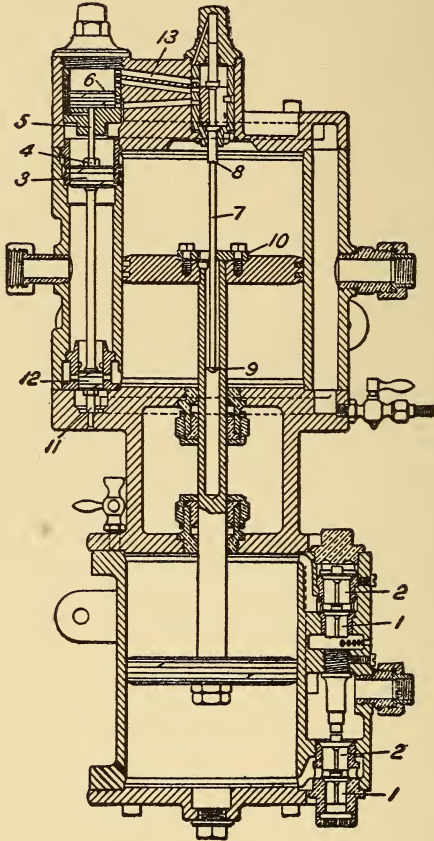

FIG. 84.—EIGHT-INCH WESTINGHOUSE AIR PUMP.

ing order. The defect should be remedied immediately upon arrival at the terminal.

These defects can be detected by an examination of the suction opening. The air will be drawn in on the slow



stroke when a delivery valve is out of action, and there will be no movement on the quick stroke.

In the case of the disabled suction valve, there will be an indraft of air on the slow stroke with a flutter and slight blow back on the quick. These defects will not serve, however, to cripple the engine nor need they necessarily nullify the action of the air brake.

In the steam cylinder those parts most liable to derangement are the pieces composing the valve motion.

When packing rings of the main valve (3) have become worn, they may cause a blow into the exhaust which should be remedied by replacing them at the first terminal. A more annoying failure occurs when the nut (4) on the valve stem on top of the main valve works off. This will cause the pump to stop and the remedy lies in the removal of the main valve and replacing it.

The stem (5) of the reversing piston is also apt to break. The result of this may or may not be the stopping of the pump. The latter will run all right until the reversing piston (6) becomes tilted and binds in the cylinder. When this occurs the pump can sometimes be started again by rapping the valve case with a hammer so as to jar the piston loose.

The stem (7) of the reversing valve is also liable to give trouble. If the shoulder (8) or button (9) becomes worn or battered the pump will be apt to pound. In case the stem is bent it may bear so hard against the reversing plate (10) as to cause reversal before the end of the

stroke is reached. Straightening the rod will remedy this difficulty, and this should be done at the end of the run.

Any of these defects may cause the pump to stop, but such failure can frequently be remedied by rapping the shell or valve case, with the exception of a loose nut (4) on top of the piston. In that case the stoppage is apt to be permanent and the remedy as already stated lies in the replacement of the nut.

A complete stoppage may also be caused by the breakage of the stop pin (11). This allows the main valve to move down so far that the packing rings of the small piston (12) catch beneath the bushing and thus hold everything in that position. This is a troublesome defect to remedy, and had best be postponed until the shops are reached unless it can be jarred loose by rapping on the casing, as may sometimes be done. A rough way of doing it, however, will be to take off the cylinder head and pull the valve out by sheer force, and then put a pin or block in place to prevent the valve from traveling as far again.

Sometimes oil works in through the pump and lodges in the small passage (13) leading from the reversing valve to the top of the reversing piston. When this passage becomes stopped entirely, reversal is impossible, and the pump stops. This defect usually gives ample warning by the slow reversal of the pump and it should be cleaned out before it is closed entirely.

*Q. What troubles are likely to occur with a nine-and-a-half-inch air pump?*

A. This pump is shown in section parallel and trans-

verse to the center line of the boiler in Fig. 85. The mechanism of the air cylinder is essentially the same as that of the eight-inch pump considered in the previous question and is subject to the same troubles. The reversing valve is also moved by the same arrangement of stem with a shoulder and

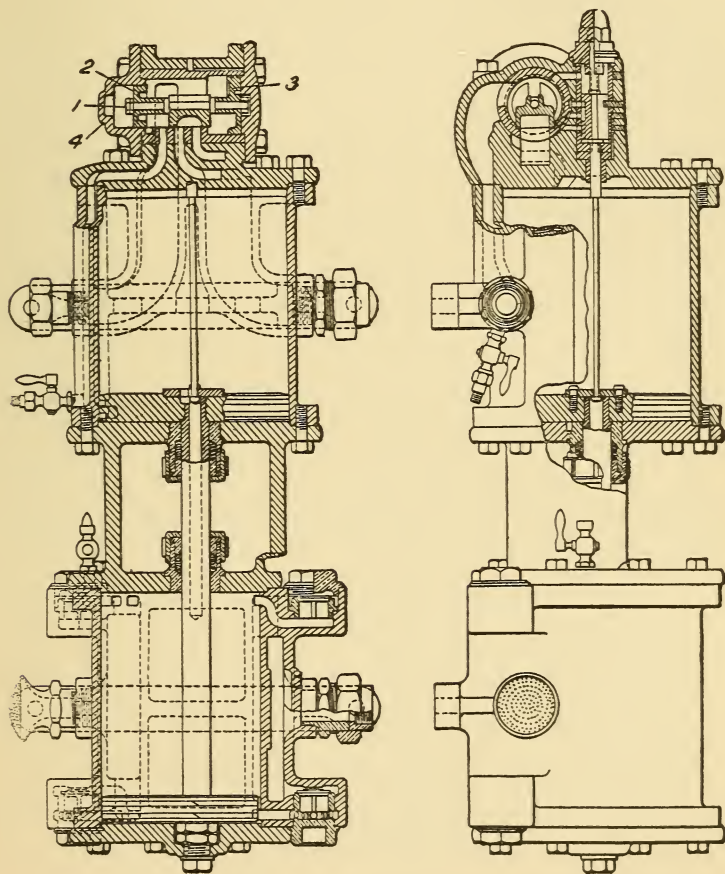

FIG. 85.—NINE-AND-ONE-HALF-INCH WESTINGHOUSE AIR PUMP.

button, and is liable to the same disorders, which call for the same remedies.

The reversing valve and main valves are, however, different. They are enclosed in a casing on the cylinder head where they are readily accessible for inspection and repairs. The construction is such that there is little or no likelihood of failure. The principal disabling accident that may occur is the working off of the nuts (1) on the valve stem, allowing it to be pulled out of the small piston (2) when the large one (3) is moved to the right. This at once stops the pump.

The remedy will be to remove the left-hand head (4) and replace the nuts. The whole valve motion of this pump lends itself very readily to repairs in that it is all attached to the top cylinder head and can be removed and another substituted as recommended in certain instances in the answer to the next question.

*Q. What recommendation can be made to enable an engineer to remedy air brake failures with the utmost dispatch?*

A. He should make himself thoroughly familiar with all parts of the mechanism so as to be able to locate any failure or threatened failure at once. If the trouble is of such a character that a remedy cannot be applied upon the road, it is frequently possible to run until an engine on an inferior train is met, that is equipped with a similar apparatus, when an exchange can be quickly effected by the substitution of a perfect for an imperfect part.

*Q. What should be done in case of a failure of the tender brake?*

A. The brake should be cut out and the train hauled to the end of the division without any delay.

*Q. What should be done in case of the failure of the driver brakes?*

A. The brake should be cut out as in the case of the tender brake and no delay caused, as suggested in the answer to the previous question.

*Q. What should be done in case one or more of the connections of the driver or tender brake should be broken?*

A. As these parts are subjected to considerable strain and as the operation of the engine is not dependent upon them, it is inadvisable to spend time in trying to effect repairs upon the road. The proper course to pursue is to remove all of the broken parts and those that are liable to fall or give trouble, cut out the brake upon which the failure has occurred, and proceed.

*Q. What is usually the cause of overheating of the air cylinders of an air pump, and how can it be remedied?*

A. The most common cause of heating of these cylinders is a leak of the delivery valves whereby air already under compression enters the cylinder with the suction. This air is not only itself at a higher temperature than the outside free air, but tends to raise the normal pressure during the early portions of the stroke. Both of these elements tend to raise the temperature of compression and thus produce overheating.

The final remedy for this will of course be to stop the

leak. On the road the emergency remedy will be to run the pump as slowly as possible. The efficiency of this depends not upon the basis that any less heat is produced per stroke than before, but that a longer time is occupied in its production, thus giving the metal of the cylinder more time to carry it off and radiate it into the air. Such overheating should be reported at the terminal.

*Q. What are some of the causes of an uneven stroke of the air pump?*

A. A badly worn valve motion; wear of the reversing parts and leakage either at the suction or discharged valves. As these are matters that necessitate shop repairs nothing can or need be done upon the road to remedy them.

*Q. What should be done to start an air pump if it stops without this being due to the action of the governor?*

A. It should first be tapped lightly on the nut over the reversing piston, and then at the base of the main valve casing if it is an eight-inch pump.

Should this fail to have the desired effect, the throttle should be closed and kept in that condition until the steam contained in the piping and cylinder has had a chance to condense. Then open the throttle wide and quickly. The entering steam then strikes what practically amounts to a blow upon the motionless parts and may thus start them. If this does have the desired effect, the throttle should be kept open somewhat wider than had been the practice before.

If the closing and opening of the throttle merely causes the pump to make one up-and-down stroke and this is repeated at each successive trial, it indicates that the reversing

valve lever is not moved to its lower position. If an examination shows that the trouble does not lie in these parts and a removal of the lower head of the air cylinder fails to show it, then an examination should be made to determine whether steam is reaching the cylinder or not.

The recommendation of the Association of Railroad Air Brake Men on this point is that if it is "either a 9½-inch or duplex pump, this can be ascertained by opening the drain cock between the governor and the main steam valve. If it is a 6-inch or 8-inch pump, and the governor is connected to the train-pipe pressure, close the cock beneath the brake valve or back of tender. Place the brake valve handle in the service application position, and if, when the train-pipe pressure is reduced or entirely discharged, the pump starts, the trouble lies with the governor. Where the governor is connected to the main reservoir, cut out as before, and, without previously discharging any pressure, disconnect the air pipe union on the governor. If the pump then starts it indicates that the fault is with the governor. In either instance remove the top of the governor and clean the diaphragm valve and seat; the former having evidently been held open by some obstruction. In no case should the adjusting nut of the governor be screwed down, as by so doing the diaphragm, its valve, and the seat of the latter may be ruined. Rare instances are known where the governor or piston bound at the lower end of its stroke and would not raise on the pressure being reduced. To test for this, after the air pressure is removed, jar the steam pipe near the governor.

In all of these governor tests the pump throttle should be kept open."

If it has been found that steam reaches the pump it is quite possible that the packing rings of the lower end of the main valve are caught beneath the bushing, when the case should be handled as detailed in the answer on page 219.

*Q. What should be done in case the air brakes are applied from some unknown cause?*

A. The following rule has been formulated by the committee of the Master Mechanics' and Master Car Builders' Associations covering this point: "If it is found that the train is dragging at any time without a rapid fall of the black pointer, move the handle of the engineer's valve into the full release position for a few seconds, and then return it to the running position.

"If, however, the brakes go on suddenly with a fall of the black pointer, it is evidence that: a conductor's valve has been opened; a hose has burst or other serious leak has occurred, or the train has parted.

"In such an event, place the handle of the engineer's valve in the lap position immediately to prevent an escape of air from the main reservoir, and leave it there until the train has stopped, the brake apparatus has been examined and a signal to release been given."



## CHAPTER XVII.

### **Aid to the Injured.**

*Q. What are some of the things that it is desirable railroad men should know in order to relieve distress due to accidents?*

A. They should know how to revive a man who is unconscious, how to stop bleeding, how to apply bandages, how to treat burns and scalds, and how to carry a person who is unconscious or disabled.

*Q. How should an unconscious man be treated?*

A. The unconscious patients who will require the attention of railroad men will be those who are rendered so by accidents, resulting in shocks or concussions or extensive burns, and it is to be understood that unconsciousness only resulting from these causes will be considered.

The object of the treatment will be to produce a reaction which may be ushered in by vomiting, accompanied by a stronger pulse and a return of color to the face. The patient should, therefore, be wrapped in blankets and rubbing be applied to the arms and legs while, if possible, hot water bottles should be put against the feet and between the thighs. The patient should, of course, be placed in a recumbent position with the head quite low.

If he is able to swallow, small quantities of hot stimulants, such as whiskey or brandy, should be administered quite frequently until the reaction takes place, after which

the quantity should be curtailed, as an excessive use of stimulants will be injurious.

If the state of unconsciousness continues, artificial respiration should be resorted to. The method to be pursued is as follows:

“Lay the patient flat on his back, loosen all tight clothing about the neck, chest, and abdomen, and loosen the suspenders, place a block or hard pillow under the patient’s shoulders (in order to raise the chest, extend the neck and throw the head back), draw forward the tongue and get an assistant to hold it in the corner of a handkerchief between the thumb and finger; if unassisted, fasten the tongue around the chin by an india rubber band or a piece of string.

“Now kneel at the patient’s head; take hold of his arms above the elbows and carry them well over the head as far back as they will go; this will have the effect of expanding the chest. Hold the arms in this position for two seconds, then bring them down against the ribs, cross the forearms over the pit of the stomach, and kneeling forward, make steady pressure upon the sides and front of the chest. Keep up this pressure for two seconds. This will have the effect of expelling the air from the chest.

“Repeat the above movements carefully and deliberately about fifteen times a minute till the natural respiration becomes established. This will be indicated by the patient beginning to take short gasps. Then cease the movements, but watch the patient carefully for some time, as the respiration, after being once established, is again liable to fail and may have to be restored.

“If the expansion and compression of the chest are efficiently performed the flow of air in and out of the throat can be distinctly heard.”

*Q. What should be done for bleeding?*

A. There are three kinds of bleeding, and each requires a somewhat different treatment. These are capillary, venous, and arterial bleeding. The first is the least dangerous of the three, and is characterized by the oozing of the blood from the whole surface of the wound. The treatment to be applied is to first expose the wound to the air and then apply pressure so as to close the small vessels from which the blood is escaping. The usual method is to apply a bandage with clean lint beneath. Linen is preferable to cotton for this purpose. If this does not stop it something should be done to coagulate the blood, which will thus seal the vessels. The wound may be washed with cold water or with hot whose temperature is about 115 degrees Fahr. Or the part may first be dried and a little salt sprinkled over it. Care should be taken not to apply too much of the latter, as an excess will injure the tissues.

In venous bleeding the blood is of a darker color than in either capillary or arterial bleeding, and flows in a continuous stream. It comes from a vessel leading to the extremities of the limbs.

The bleeding part should be elevated if possible so that it is higher than the heart; all restrictions preventing the backward flow of blood to the heart, such as garters, etc., should be removed. With clean hands a pressure should first be applied directly to the surface of the wound, and it

should then be bandaged with a clean pad. The wounded part should be kept elevated for some time, even after the bleeding has stopped.

Arterial bleeding is the most serious of the three, as it offers a direct outlet from the heart and prompt action will be required. Its characteristics are that the blood is of a bright scarlet color and that it may issue in spurts corresponding to the beat of the heart. This last may be scarcely apparent to the eye, however, as the wound may be of such a character that the flow of blood may be partly checked by the condition of the flesh.

The bleeding may be stopped, as in the case of venous bleeding, by applying a pressure of the fingers to the wound. This may be done with one hand, while with the other the artery may be located by its pulse. It should then be pressed firmly against the bone with a sufficient force to stop the bleeding, but not to hurt the patient. When this has been done the pressure of the fingers can be replaced by bandages accomplishing the same results. These, of course, are to be placed between the wound and the heart.

*Q. How are bandages made and how should they be applied?*

A. There are two main forms of bandages that can be used for emergencies. One is triangular and the other a long strip. The former will be found to be by far the more convenient of the two as well as more readily obtainable. It is usually at hand in the form of a handkerchief, a white signal flag, or any square piece of cloth that may be folded across the corners and either cut or left folded to form the

triangular strip. To be most efficient it should measure about a yard along each edge. It will be advisable not to tear the square cloth into strips. It will be impossible to illustrate all possible applications of the triangular bandage, but a few examples are shown. Fig. 86 is an application to the head; Fig. 87 shows the method of tying for the temples



FIG. 86.—APPLICATION OF TRIANGULAR BANDAGE TO THE HEAD.



FIG. 87.—TEMPLE AND JAW TIED WITH TRIANGULAR BANDAGE.

or jaws; Fig. 88 represents the triangular bandage as used as a sling; and Fig. 89 represents it tied about the hand.

In the tying of the bandage a reef or square knot should always be used, and a granny knot avoided. The former is easily untied and will not slip, while the latter may fail at any moment, leaving the patient in a critical and dangerous position.

The strip bandage is wound about the body or injured

part as shown in Fig. 90, which represents it applied to the hand where the latter has been burned, bruised, or sprained.

*Q. What is a tourniquet, and for what is it used?*

*A. A tourniquet is a form of bandage so constructed*



FIG. 88.—TRIANGULAR BANDAGES USED AS A SLING AND ABOUT A WOUNDED ARM.

that it will bring a pressure to bear upon the vein or artery to check the flow of blood, and, at the same time, not cause an undue pressure upon the other parts of the limb or body.

It is made by placing some hard substance, such as a cork, or in case of need a small stone, in the folds of a bandage to act as a pad. A triangular bandage folded like a necktie answers the purpose admirably. This pad is placed

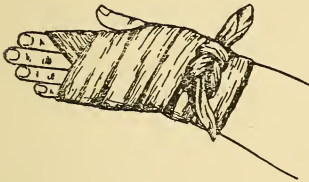

FIG. 89.—TRIANGULAR BANDAGE TIED ABOUT THE HAND.



FIG. 90.—WOUNDED HAND BANDAGED WITH A STRIP BANDAGE.

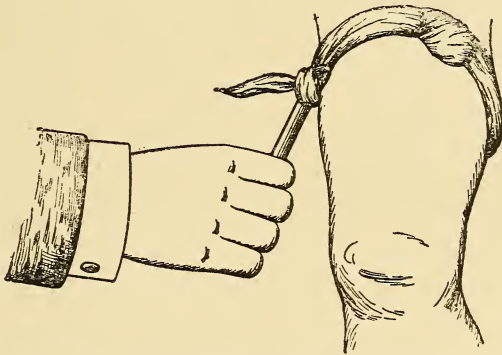

FIG. 91.—TOURNIQUET APPLIED TO LIMB.

over the artery and the bandage is tied loosely over a soft pad placed on the other side of the limb. A bandage knotted firmly over it. The stick is then twisted around until the hard pad has compressed the artery and stopped the flow of blood. The end is then made fast by another pad, as shown

in Fig. 91, which represents the application of the tourniquet to the thigh.

*Q. How should burns and scalds be treated?*

A. The first thing to be done is to remove the clothing from the injured part. This should be done very gently, and the utmost care taken not to break any blisters. It should, therefore, be cut off and not dragged over the injured flesh. If any of it adheres to the body it should be first soaked in oil before attempting to remove it. If this will not free it the part should be immersed in warm water. In the case of extensive burns attend to only one portion of the body at a time.

The bandages that are applied to the burned part should be soaked in a saturated solution of common washing soda in water or should be spread over with a mixture of equal parts of boracic acid ointment and vaseline. Under ordinary conditions the washing soda will be more easily obtained than the boracic acid ointment and vaseline.

*Q. How can one person easily lift and carry another that is unconscious?*

A. The lifting of an unconscious person who is limp and helpless is a matter of extreme difficulty and becomes almost impossible if a straight lift is attempted on the part of the unskilled. It is, however, comparatively easy if what is known as the fireman's lift is used.

For the following description of the fireman's lift, with the accompanying illustrations, acknowledgment is made to the ambulance handbook of Drs. Warwick and Tunstall:  
"Kneeling down on both knees, first turn the patient face



downward, straighten arms down by his sides, as in Fig. 92, and take hold close up under each armpit, then raise the



FIG. 92.—THE FIREMAN'S LIFT, FIRST POSITION.

body as high as it can be lifted in that position, and allow it to rest on one of the knees as in Fig. 93, then shift the arms round the waist, and after interlocking the fingers lift



FIG. 93.—THE FIREMAN'S LIFT, SECOND POSITION.

the person to an upright position as in Fig. 94. After this take hold of the patient's right wrist with the left hand and bring his right arm round your neck, place your head



FIG. 94.—THE FIREMAN'S LIFT, THIRD POSITION.



FIG. 95.—THE FIREMAN'S LIFT, FOURTH POSITION.



FIG. 96.—THE FIREMAN'S LIFT, FIFTH AND FINAL POSITION, WITH THE PATIENT ON THE SHOULDERS.



beneath his body and drop into a stooping position; at the same time pass your right arm between or round the patient's legs, and bring his weight well on to the center of the back as in Fig. 95; then grasp the patient's right wrist with your right hand and, balancing the body on the shoulders, rise to the erect position of Fig. 96.

"This method is applicable to a person who is in a state of unconsciousness, but in whom the extremities are uninjured."

Where two or more persons are available to assist in the carrying the work is much simpler, as the body may be carried in the arms between two, or laid out upon a stretcher and this in turn carried by several.

# INDEX.

	PAGE		PAGE
ACCIDENTS, preparation for emergencies and .....	17	Boller depreciation resulting in explosions, some causes of .....	122
Air brake apparatus, causes of trouble with.....	217	Deterioration due to accumulation of scale, prevention of .....	125
Applying from unknown causes .....	226	Refilling .....	125
Failures, remedying....	222	Bollers to stand under pressure, danger of allowing...	114
Air brake pump, cause of overheating of cylinder of .....	223	Bolts, removal of partially sheared rod .....	66
Cause of uneven stroke of .....	224	Starting tight .....	206
Starting defective.....	224	Brake, broken connections to driver and tender.....	223
Troubles with 9½-inch..	220	Failure of tender.....	223
Troubles with the.....	217	Failures of driver.....	223
Axle, action to be taken with broken driving .....	78	Brasses, method of filing worn rod .....	166
Broken tender .....	155	Necessity of having engine in tram for keying rod .....	172
Causes of heating of driving .....	163	Breakdown, first duties in case of .....	11, 12, 156
Hot tender or truck....	164	Bridge, action in case of a broken .....	18
Of consolidation or mogul locomotive, remedy for broken .....	97	Detecting a broken.....	17
Remedy for broken four-wheeled truck.....	95	Strengthening a cracked .....	214
Running of engine with a broken truck .....	98	Bulged firebox sheet, action in case of.....	124
BALDWIN four-cylinder cross-compound locomotive. See Compound locomotive.		Bulging of a firebox sheet, cause of .....	123
Bandages, forms and applications of .....	230	Burns and scalds, treatment of .....	234
Bearings, causes of hot....	163	Bushings in cylinders, method of putting .....	62
Hot main axle.....	163	In rebored cylinders, use of .....	61
Bell ringer, failure of.....	150	By-pass valve of Richmond compound locomotive, plugging .....	181
Bleeding, stopping.....	229	Valves of Richmond compound locomotive stuck open .....	180
Blow in Vauclain compound locomotive, continuous ...	197	Valves of Richmond compound locomotive stuck shut .....	181
In Vauclain compound locomotive, location of .....	198	CELLARS of driving boxes, removal of .....	203
Blow-off cock, clogged.....	112	Center casting, broken engine truck .....	102
Blow of valve, detecting..	15, 16	Center pin of pony truck, broken .....	102
Blows, development of sudden .....	17, 18		
Due to wear of piston packing, detection of. ....	65		
In two-cylinder compound locomotive ...	193		
In Vauclain compound locomotive .....	196		
Location of piston .....	17		

	PAGE		PAGE
Check valve, cocked .....	140	Compound locomotive:	
Knocked off .....	140	ing valve of two-cylin-	
Stuck open .....	139	der .....	185
Compound locomotive, acci-		Stuck open, by-pass	
dents to .....	174	valves of Richmond...	180
Accidents to intercept-		Stuck open, emergency	
ing valve of Rich-		valve of Richmond...	177
mond .....	174	Stuck open, emergency	
Accidents to intercept-		valve of Schenectady,	191
valve of Schenectady,	185	Stuck open, intercepting	
Apt to get out of order,		valve of Richmond...	175
special parts of ....	174	Stuck open, intercepting	
Blows in two-cylinder..	193	valve of Schenectady.	185
Blows in Vauclain....	196	Stuck shut, by-pass valve	
Broken auxiliary steam		of Richmond .....	181
pipe of a .....	183	Stuck shut, emergency	
Broken emergency valve		valve of Richmond ..	177
of Richmond .....	179	Stuck shut, intercepting	
Broken equalizing valve		valve of Schenectady.	185
of Vauclain .....	195	Treatment of breakage of	
Broken intercepting valve		pistons, valves and	
of Richmond.177, 178,	179	crossheads of four-cyl-	
Broken intercepting valve		inder cross .....	200
of Schenectady...187,	189	Use of one cylinder of	
Broken receiver of two-		pair in Baldwin cross.	201
cylinder .....	182	Working one side of two-	
Broken valve of Bald-		cylinder .....	192
win four-cylinder cross	201	Connecting rod for discon-	
Broken valve of tandem,	201	necting, holding a .....	203
Detection of leaky start-		Inspection of a side and.	77
ing valve of Vauclain,	196	Remedy for a broken ...	70
Disabled cylinder of Vau-		Set screws and key nuts,	
clain, .....	195	remedy for lost .....	71
Disabled side of Vau-		Strap, remedy for broken,	71
clain .....	194	Crank pin, cause of hot... 165	
Disconnecting two-cylin-		Remedy for broken main,	72
der .....	192, 193	Crosshead gib, remedy for a	
Effect of leaky starting		broken .....	69
valve of Vauclain ...	196	Crosshead, method of block-	
Inequality of exhaust of		ing .....	20
Vauclain .....	197	Of four-cylinder cross-	
Leaks of intercepting		compound locomotives,	
valve of Richmond... 183		treatment of breakage	
Leaks of intercepting		of .....	200
valve of Schenectady.	190	Remedy for a broken... 69	
Leaky piston rings in		Crownsheet, overheating of a	122
two-cylinder .....	193	Uncovered .....	110
Leaky valves in two-cyl-		Cylinder cocks on disconnect-	
inder .....	194	ed engine, adjustment of.. 60	
Location of blow in		Cylinder head, broken .....	58
Vauclain .....	198	Cause of broken .....	59
Open, objection to fast		Prevention of broken... 59	
running with emergen-		Cylinder of pair in Baldwin	
cy valve of Richmond,	177	cross-compound locomotive,	
Plugging by-pass valve of		use of one .....	201
Richmond .....	181	Of Vauclain compound	
Repairing and readjust-		locomotive, disabled .. 195	
ing intercepting valve		Remedy for broken.... 60	
of Richmond .....	178	Remedy for groaning in. 65	
Stuck closed, intercept-		Cylinders, cause of deteriora-	
ing valve of Richmond,	176	tion of .....	61
Stuck closed, intercept-		Cause of water in .....	108

	PAGE		PAGE
Cylinders:		Emergency valve:	
Method of re boring....	61	Of Schenectady com-	
Use of bushings in re-		pound locomotive stuck	
bored .....	61	open .....	191
Cylinder with broken front		Equalizer, broken .....	103
head, use of.....	58	Injured .....	107
DEAD ENGINE for towing,		Of mogul engine, broken	
disconnecting a.....	167	cross .....	104
Pumping pressure into a,	157	Of mogul engine, broken	
Deflector plate. See Dia-		intermediate .....	104
phragm.		Stand, broken .....	104
Derailed engine .....	157	Equalizing valves of Vauclain	
Deterioration of boiler sheets,		c o m p o u n d locomotive,	
effect of form on the.....	115	broken .....	195
Diaphragm, readjustment of		Exhaust, causes of variations	
a .....	129	Issuing from side of	
Disconnected, stopping with		stack, causes of ....	133
one side .....	168	Normal character of....	27
Disconnecting dead engine for		Of Vauclain compound	
towing .....	167	locomotive, inequality	
Engine with disabled		of .....	197
valve, method of....	19	Pipe joints, location of	
Two-cylinder compound		leaky .....	113
locomotive .....	192, 193	To fill the stack, failure	
Drawbar between engine and		of the .....	133
tender, broken .....	153	Explosion, progressive action	
Driving box, best position for		of a boiler .....	117
packing .....	172	Explosions, some causes of	
Brass, remedy for broken		boiler depreciation result-	
en .....	85	ing in .....	122
Cause of pounding of..	87	Some causes of locomo-	
Effect of stuck .....	89	tive boiler .....	120
On ten-wheeled engine,		Source and magnitude of	
remedy for broken... 86		energy set free in boiler	
Remedy for broken .... 86		.....	118
Removal of cellar of.... 203		Testing of hydrostatic	
Dry pipe, collapsed .....	126	pressure as a safeguard	
Difference between leaky		against boiler, .....	119
throttle valve and.... 127		Extension rod, broken link.. 40	
ECCENTRIC, broken..... 44		FIREBOX sheets, exposed.... 161	
Hot .....	48	Fire, method of extinguish-	
Eccentric rod, broken.... 43		ing .....	161
Slipped .....	44	With water, danger of	
Eccentric, slipped ... 45, 46, 47		quenching .....	162
Eccentric strap, broken.... 45		Flue. See Tube.	
With the rods, necessity		Foaming boiler, action to be	
of removing the..... 48		taken with .....	109
Emergencies and accidents,		Detection of .....	108
preparation for .....	17	Difference between prim-	
Emergency valve of Richmond		ing and .....	108
compound locomotive, broken,		Of oily water, checking	
.....	179	the .....	109
Of Richmond compound		Frame, broken engine .....	106
locomotive open, objec-		Remedy for broken truck,	
tion to fast running		Welding broken .....	212
with .....	177	Frogs, forms of wrecking... 159	
Of Richmond compound		Front, broken .....	132
locomotive stuck open.	177	Fusible plug, melted .....	110
Of Richmond compound		GAUGE GLASS, broken .... 148	
locomotive stuck shut. 177		Cutting a .....	149

	PAGE		PAGE
Gauge-glass :		Intercepting valve :	
Indication of defect in..	148	Locomotive stuck	
Replacing a broken ....	149	closed .....	176
Gib, remedy of a broken cross-		Of Richmond compound	
head .....	69	locomotive stuck open,	175
Gland, broken valve stem or		Of Schenectady com-	
piston rod .....	24	pound locomotive, acci-	
Grate with deep hopper ash-		dents to .....	184
pan, broken drop .....	113	Of Schenectady com-	
With shallow ash-pan,		pound locomotive,	
broken drop .....	113	broken .....	187, 189
Grooving of boiler plates,		Of Schenectady com-	
cause of .....	123	pound locomotive,	
Guide, remedy for a broken..	67	leaks of .....	190
Remedy for hot .....	68	Of Schenectady com-	
Guide yoke, remedy for bent		pound locomotive	
or broken .....	68	stuck open .....	185
HANDHOLE plate, blown out .	124	Of Schenectady com-	
Headlight in high wind, light-		pound locomotive stuck	
ing a .....	205	shut .....	185
Heating of driving axles,		Of two-cylinder com-	
cause of .....	163	pound locomotive stuck	
Hose, broken or burst .....	153	closed .....	185
Hot bearings, causes of .....	163	KEYING rod brasses, necessity	
With water, objections to		of having engine in	
cooling .....	165	tram for .....	172
Hot crank pins, cause of .....	165	Key nuts, remedy for lost con-	
Crosshead .....	164	necting rod setscrews and.	71
Eccentric strap .....	164	Knots and hitches .....	208
Guides .....	164	LEAKY pistons, characteristics	
Main axle bearings .....	163	of blows of .....	17
Rod brass .....	163	Valve, location of .....	15, 16
Tender or truck axle .....	164	Lifting arm broken .....	39
Water to tank, objection		Lifting shaft bracket, broken	
to leakage of .....	140	en .....	40
Hydrostatic pressure as a		Broken .....	40
safeguard against boiler		Link block, broken .....	38
explosions, testing by .....	119	Broken .....	37
INJECTOR after failure,		Disabled, variation of	
method of starting .....	137	cut-off with one .....	39
Failures .....	134, 138	Extension rod, broken .....	40
Failures, causes of .....	135	Hanger, broken .....	39
Overflow, loss of water		Motion, action of the .....	48
at .....	139	Saddle, broken .....	38
Injured, details of aid to the,	227	Saddle pin, broken .....	38
Inspection of side and con-		Lubricator, cause of irregular	
necting rods .....	77	action of an automatic cyl-	
Intercepting valve of Rich-		inder .....	147
mond compound locomotive,		Failure of cylinder .....	145, 147
accidents to .....	174	MAIN ROD. See Connecting	
Of Richmond compound		rod.	
locomotive broken,		NETTING, clogged or broken ..	130
177, 178, 179		PACKING, adjustment of	
Of Richmond compound		spring piston .....	66
locomotive, leaks of ..	183	Driving box, best position	
Of Richmond compound		for .....	172
locomotive, repairing			
and readjusting .....	178		
Of Richmond compound			

	PAGE		PAGE
Packing:		REACH ROD, broken.....	41
Effect of wear on tight-		Receiver of two-cylinder com-	182
ness of split ring pis-		pound locomotive, broken,	182
ton .....	65	Repairs with pressure on the	
Rings, remedy for brok-		boiler, danger of making,	116
en metallic piston rod		Reverse lever, broken .....	41
or valve stem .....	34	Richmond compound locomo-	
Parallel rod. See Side rod.		tive. See Compound loco-	
Petticoat pipe, readjustment		motive.	
of a .....	129	Rocker arm, broken .....	35
Piston blows, location of...	17	Arm, setting valve in	
Broken .....	56	central position with	
Of tandem compound lo-		broken .....	35
comotive, broken ...	202	Box, broken .....	36
Packing, adjustment of		Pin, broken .....	36
spring .....	66	Rod bolts, removal of partial-	
Rings in two-cylinder		ly sheared .....	66
compound locomotives,		Brasses, method of filing	
leaky .....	193	worn .....	166
Piston rod, broken .....	56	Brasses, necessity of hav-	
From crosshead, difficulty		ing engine in tram for	
of removing .....	57	keying .....	172
From crosshead, method		Brass, hot .....	163
of removing .....	57	Running gear, inspection of..	97
Gland, broken valve stem			
or .....	24	SAFETY valve broken off....	127
Pistons, characteristics of		Sand on one side only, us-	
blows of leaky.....	17	ing .....	168
Of four-cylinder cross-		On slippery rails, use of,	156
compound locomotives,		On slipping engine, use	
treatment of breakage		of .....	168
of .....	200	Scalds, treatment of burns	
Piston valves, method of		and .....	234
testing .....	30	Scale from injector tubes, re-	
Sticking, cause of .....	30	moval of .....	140
Plates. See Sheets.		Prevention of boiler de-	
Plugs, blown out.....	124	terioration due to ac-	
Pounding in locomotives,		cumulation of .....	125
cause of .....	169	Schenectady compound loco-	
Of driving boxes, cause		motive. See Compound lo-	
of .....	87	comotive.	
Of driving boxes, remedy		Setscrews and key nuts, rem-	
for .....	88	edy for lost connecting rod,	71
Of driving boxes, varia-		Sheet, action in the case of a	
tion in .....	87	cracked .....	116
Pound, locating a.....	171	Blistered .....	117
Pressure, danger of allowing		Effect of form on the de-	
boilers to stand under....	114	terioration of boiler..	115
Priming and foaming, differ-		Exposed, firebox .....	161
ence between .....	108	Side rod, action in case of	
Boiler, action to be tak-		broken sectional .....	74
en, with .....	109	And connecting rods, in-	
Pump, cause of overheating		spection of .....	77
cylinder of air brake....	223	Cause of breakage of....	74
Cause of uneven stroke		Keying .....	76
of air brake .....	224	Necessity of removing	
Failure .....	141	both .....	72
Troubles with the air		On switching engines,	
brake .....	217	running with broken.	75
Troubles with 9½-inch		On tandem connected en-	
air brake .....	220	gine, breakage of ....	73



	PAGE		PAGE
Side rod:		Tourniquet, form and use of	
Remedy for broken .....	72	the .....	232
Snow, engine stalled in the.	166	Towing, disconnecting dead	
Spring against breaking, pro-		engine for .....	167
tection of cracked driving,	91	Transom for four-wheeled	
Broken engine truck ....	103	engine truck, broken...	101
Hanger, remedy for		Troubles, locomotive.....	12
broken driving.....	91	Truck, broken tender.....	154
Hanger, remedy for brok-		Frame on mogul or con-	
en truck .....	100	solidation engine,	
Of ten-wheeled engine,		remedy for broken... 100	
blocking for broken... 93		Frame, remedy for	
Remedy for broken		broken .....	100
driving .....	93	Of consolidation or mo-	
Stirrup, remedy for		gul locomotive, remov-	
broken driving.....	91	al of .....	98
Stalled in the snow, engine..	166	Tube, leaky .....	110
Starting disconnected engine			
from near dead point ... 168		UNCONSCIOUS, lifting and	
Locked driving wheels.. 172		carrying the .....	234
Valve of Vauclain com-		Treatment of the..... 227	
pound locomotive, de-			
tection of leaky..... 196		VALVE, action in case of brok-	
Valve of Vauclain com-		en .....	20
pound locomotive, ef-		Detecting blow of...15, 16	
fect of leaky .....	196	Disconnected tank..... 155	
Staybolt breakages, location		In central position with	
of .....	121	broken rocker arm,	
Detection of broken.... 121		setting .....	35
Steam chest and cover,		Lip broken .....	33
cause of breakage of .... 64		Locating a dry .....	26
Cover, remedy for broken 63		Location of leaky...15, 16	
Remedy for broken..... 62		Method of clamping... 18	
Prevention of broken... 64		Motion defects, locating 27	
Steam gauge, defective..... 152		Of Baldwin four-cylind-	
Steam pipe, broken or burst 127		er cross-compound	
Leaks in front end,		locomotive, broken... 201	
proper time to inspect		Of four-cylinder cross-	
for .....	114	compound locomotive,	
Leaky .....	128	treatment of breakage	
Of a compound locomo-		of .....	200
tive, broken auxiliary 183		Of tandem compound	
Detection of a leaky... 128		locomotive, broken .. 201	
Stopping with one side dis-		Packing strip, detection	
connected .....	168	of broken .....	24
Stop, making a quick..... 162		Remedy for a cocked... 27	
		Seats, remedy for worn 30	
TANK valve, disconnected... 155		Valves, instruction for set-	
Throttle valve and dry pipe,		ting .....	48
difference between leaky.. 127		In two-cylinder com-	
Disconnected .....	126	pound locomotives,	
Leaky .....	127	leaky .....	194
Tires, cause of loose driving		Method of testing piston 30	
wheel .....	84	Remedy for worn..... 30	
Detection of loose driv-		Valve stem, action in case	
ing wheel .....	84	of a broken .....	22
Distribution of engine		Detection of broken... 23	
weights with broken		Or piston rod gland,	
wheels and .....	83	broken .....	24
Loosening of driving		Valves sticking, cause of pis-	
wheel .....	84	ton .....	30
Remedy for broken driv-		Tests of general condi-	
ing wheel.....82, 83		tion of .....	28

	PAGE		PAGE
Valves :		Weights with broken wheels and tires, distribution of engine .....	83
To move, tendency of disabled .....	32	Wheel, broken engine truck.	101
Wear of .....	29	Broken tender .....	155
When blocked, remedy for leaky .....	32	Hubs, repairing cracked driving .....	215
Valve yoke, broken.....	22	Remedy for broken driv- ing .....	81
Detection of broken....	23	Wheels and tires, distribu- tion of engine weights with broken .....	83
Vauclain compound loco- motive. See Compound loco- motive.		Danger of running back- ward with broken rear	155
WATER glass. See Gauge glass		Starting locked driving.	172
In cylinders, cause of..	108	Whistle broken off.....	127
Wedge bolt, method of mend- ing broken .....	89	Wrecking frogs, forms of...	159
Result of a broken....	89	Wrist pin, remedy for a broken .....	70
Wedges, method of adjusting driving box .....	89		

# SCIENTIFIC and PRACTICAL BOOKS

PUBLISHED BY

NORMAN W. HENLEY & CO.

132 Nassau St., New York, U. S. A.

✍ Any of these books will be sent prepaid on receipt of price to any address in the world.

✍ We will send FREE to any address in the world our 100-page Catalogue of Scientific and Practical Books.

## **Askinson. Perfumes and Their Preparation. A Comprehensive Treatise on Perfumery :**

Containing complete directions for making Handkerchief Perfumes, Smelling Salts, Sachets, Fumigating Pastils; Preparations for the Care of the Skin, the Mouth, the Hair; Cosmetics, Hair Dyes, and other Toilet Articles. 300 Pages. 32 illustrations. 8vo. Cloth ..... \$3.00

## **Barr. Catechism on the Combustion of Coal and the Prevention of Smoke :**

A practical treatise for all interested in fuel economy and the suppression of smoke from stationary steam boiler furnaces and from locomotives. 85 illustrations. 12mo. 349 Pages. Cloth..... \$1.50

## **Blackall. Air-Brake Catechism :**

This book is a complete study of the air brake equipment, including the latest devices and inventions used. All parts of the air brake, their troubles and peculiarities, and a practical way to find and remedy them, are explained. This book contains 1500 questions with their answers, and is completely illustrated by Engravings and Twelve Large Folding Plates of the Westinghouse Quick-Action Automatic Brake, and also the 9½-inch Improved Air Pump. 305 Pages. Handsomely bound in Cloth. Eighteenth Edition..... \$2.00

## **Grimshaw. Saw Filing and Management of Saws :**

A practical handbook on filing, gumming, swaging, hammering and the brazing of band saws, the speed, work and power to run circular saws, etc., etc., Fully illustrated. Cloth..... \$1.00

## **Grimshaw. "Shop Kinks" :**

This book is entirely different from any other on machine-shop practice. It is not descriptive of universal or common shop usage, but shows special ways of doing work better, more cheaply and more rapidly than usual, as done in fifty or more leading shops in Europe

NORMAN W. HENLEY & CO.'S PUBLICATIONS.

---

and America. Some of its over 500 items and 222 illustrations are contributed directly for its pages by eminent constructors; the rest have been gathered by the author in his Thirty Years' Travel and Experience. Second Edition. Nearly 400 Pages and 222 illustrations. Cloth..... \$2.50

**Grimshaw. Engine Runner's Catechism:**

Telling how to erect, adjust and run the principal steam engines in the United States. Describing the principal features of various special and well-known makes of engines. Fourth Edition. 336 Pages. Fully illustrated. Cloth..... \$2.00

**Grimshaw. Steam Engine Catechism:**

A series of direct practical answers to direct practical questions, mainly intended for young engineers and for examination questions. Nearly 1,000 questions with their answers. Twelfth Edition. 413 Pages. Fully illustrated. Cloth..... \$2.00

**Grimshaw. Locomotive Catechism:**

This is a veritable Encyclopædia of the Locomotive, is entirely free from mathematics, and thoroughly up to date. It contains 1,600 Questions with their Answers. Twenty-second Edition, greatly enlarged. Nearly 450 Pages, over 200 illustrations, and 12 Large Folding Plates. Bound in Maroon Cloth..... \$2.00

**Hiscox. Gas, Gasoline and Oil Engines:**

Full of general information about the new and popular motive power, its economy and ease of management. Also chapters on Horseless Vehicles, Electric Lighting, Marine Propulsion, etc. Special chapters on Theory of the Gas and Gasoline Engine, Utilization of Heat and Efficiency of Gas Engines, Retarded Combustion and Wall Cooling, Causes of Loss and Inefficiency in Explosive Motors, Economy of the Gas Engine for Electric Lighting, The Material of Power in Explosive Engines. Carbureters, Cylinder Capacity, Mufflers, Governors, Igniters and Exploders, Cylinder Lubricators, The Measurement of Power, The Indicator and its Work, Heat Efficiencies, U. S. Patents on Gas, Gasoline and Oil Engines and their adjuncts since 1875, etc. 412 Pages. Large Octavo, illustrated with 312 Handsome Engravings. Tenth Edition, Revised and Enlarged. Buckram..... \$2.50

**Hiscox. Compressed Air in All its Applications:**

Giving the thermodynamics, compression, transmission, expansion, and uses for power purposes in mining and engineering work; pneumatic motors, shop-tools, air-blasts for cleaning and painting, air-lifts, pumping of water, acids and oils; aeration and purification of water supply, railway propulsion, pneumatic tube transmission, refrigeration and numerous appliances

NORMAN W. HENLEY & CO.'S PUBLICATIONS.

---

in which compressed air is a most convenient and economical vehicle for work—with tables of compression, expansion and the physical properties of air. Large octavo. 800 Pages. 600 illustrations. Fourth Edition, Revised. Price..... \$5.00

**Hiscox. Horseless Vehicles, Automobiles and Motor Cycles, Operated by Steam, Hydro-Carbon, Electric and Pneumatic Motors:**

The make-up and management of Automobile Vehicles of all kinds are treated. It also contains a complete list of the Automobile and Motor Manufacturers with their addresses as well as a list of patents issued since 1856 on the Automobile industry. Nineteen Chapters. Large 8vo. 316 illustrations. 460 Pages. Cloth. \$3.00

**Hiscox. Mechanical Movements, Powers, Devices and Appliances:**

This is a new work on Illustrated Mechanics, Mechanical Movements, Devices and Appliances, covering nearly the whole range of the practical and inventive field, for the use of Mechanics, inventors, Engineers, Draughtsmen, and all others interested in any way in mechanics. Large 8vo. Over 400 Pages. 1,800 Specially Made Illustrations, with Descriptive Text. Tenth Edition..... \$3.00

**Inventors' Manual; How to Make a Patent Pay:**

This is a book designed as a guide to inventors in perfecting their inventions, taking out their patents and disposing of them. 119 Pages. New Edition. Cloth.. \$1.00

**Krauss. Linear Perspective Self-Taught:**

The underlying principle by which objects may be correctly represented in perspective is clearly set forth in this book, everything relating to the subject is shown in suitable diagrams, accompanied by full explanations in the text. Price..... \$2.50

**LeVan. Safety Valves; Their History, Invention and Calculation:**

Illustrated by 69 Engravings. 151 Pages..... \$1.50

**Parsell & Weed. Gas Engine Construction:**

A practical treatise describing the theory and principles of the action of gas engines of various types, and the design and construction of a half-horse power Gas engine, with illustrations of the work in actual progress, together with dimensioned working drawings, giving clearly the sizes of the various details. Second Edition Revised and Enlarged. 25 Chapters. Large 8vo. Handsomely Illustrated and Bound. 300 Pages. \$2.50

**Beagan, Jr. Electrical Engineers' and Students' Chart and Handbook of the Brush Arc Light System:**

Illustrated. Bound in Cloth, with Celluloid Chart in Pocket. 8vo. Cloth..... \$1.00

NORMAN W. HENLEY & CO.'S PUBLICATIONS.

**Sloane. Electricity Simplified:**

The object of "Electricity Simplified" is to make the subject as plain as possible, and to show what the modern conception of electricity is. 158 Pages. Illustrated ..... \$1.00

**Sloane. How to Become a Successful Electrician:**

It is the ambition of thousands of young and old to become electrical engineers. Not every one is prepared to spend several thousand dollars upon a college course, even if the three or four years requisite are at their disposal. It is possible to become an electrical engineer without this sacrifice, and this work is designed to tell "How to Become a Successful Electrician," without the outlay usually spent in acquiring the profession. Twelfth Edition. Revised and Enlarged. 200 Pages. Illustrated. Cloth..... \$1.00

**Sloane. Arithmetic of Electricity:**

A Practical Treatise on Electrical Calculations of all kinds, reduced to a series of rules, all of the simplest forms, and involving only ordinary arithmetic; each rule illustrated by one or more practical problems, with detailed solution of each one. Fourth Edition. Illustrated. 138 Pages. Cloth..... \$1.00

**Sloane. Electric Toy Making, Dynamo Building and Electric Motor Construction:**

This work treats of the making at home of Electrical Toys, Electrical Apparatus, Motors, Dynamos and Instruments in general, and is designed to bring within the reach of young and old the manufacture of genuine and useful electrical appliances. Third Edition. Fully Illustrated. 140 Pages. Cloth..... \$1.00

**Sloane. Rubber Hand Stamps and the Manipulation of India Rubber:**

A practical treatise on the manufacture of all kinds of Rubber articles. 146 Pages. Second Edition. Cloth. \$1.00

**Sloane. Liquid Air and the Liquefaction of Gases:**

Containing the full theory of the subject, and giving the entire history of liquefaction of gases, from the earliest times to the present. It shows how liquid air like water is carried hundreds of miles and is handled in open buckets. It tells what may be expected from it in the near future. 365 Pages, with many Illustrations. Handsomely bound in Buckram. Second Edition ..... \$2.50

**Sloane. Standard Electrical Dictionary:**

A practical handbook of reference, containing definitions of about 5,000 distinct words, terms and phrases. An entirely New Edition, brought up to date and greatly enlarged. Complete, Concise. Convenient. 682 Pages, 393 Illustrations. Handsomely bound in Cloth. Svo. .... \$3.00

NORMAN W. HENLEY & CO.'S PUBLICATIONS.

---

**Usher. The Modern Machinist:**

A practical treatise embracing the most approved methods of modern machine-shop practice, and the applications of recent improved appliances, tools and devices for facilitating, duplicating and expediting the construction of machines and their parts. A new book from cover to cover. Third Edition. 257 Engravings. 322 Pages. Cloth..... \$2.50

**Van Dervoort. Modern Machine Shop Tools; Their Construction, Operation and Manipulation, Including Both Hand and Machine Tools:**

A new work treating the subject in a concise and comprehensive manner. A chapter on Gearing and Belting, covering the more important cases, also the Transmission of Power by Shafting with formulas and examples is included. This book is strictly up-to-date and is the most complete, concise and useful work ever published on this subject. Containing 550 Pages and 673 Illustrations..... \$4.00

**Woodworth. Dies, Their Construction and Use for the Modern Working of Sheet Metals:**

A treatise upon the designing, constructing and use of tools, fixtures and devices, together with the manner in which they should be used in the power press for the cheap and rapid production of sheet metal parts and articles. Comprising fundamental designs and practical points by which sheet metal parts may be produced at the minimum of cost to the maximum of output, together with special reference to the hardening and tempering of press tools, and to the classes of work which may be produced to the best advantage by the use of dies in the power press. Containing 400 Pages. 500 Illustrations..... \$3.00

**Woodworth. Hardening, Tempering, Annealing and Forging of Steel:**

A new book containing special directions for the successful hardening and tempering of all steel tools. Milling cutters, taps, thread dies, reamers, both solid and shell, hollow mills, punches and dies and all kinds of sheet-metal working tools, shear blades, saws, fine cutlery, and metal-cutting tools of all descriptions, as well as for all implements of steel, both large and small, the simplest and most satisfactory hardening and tempering processes are presented. The uses to which the leading brands of steel may be adapted are concisely presented, and their treatment for working under different conditions explained, as are also the special methods for the hardening and tempering of special brands. Containing 288 Pages, about 201 Illustrations ..... \$2.50

JUST PUBLISHED.

Eighteenth Edition.

Greatly Enlarged and Revised.



---

---

# AIR BRAKE CATECHISM.

---

---

BY ROBERT H. BLACKALL. Air Brake Inspector and Instructor, Westinghouse Air Brake Co.

312 Pages. Fully Illustrated and Containing Two Large Westinghouse Air Brake Educational Charts, Printed in Colors.

PRICE, \$2.00.

**A** NEW book from cover to cover, being a complete study of the Westinghouse Air Brake equipment, and includes the latest devices and inventions used. All parts of the Air Brake, their troubles and peculiarities and a practical way to find and remedy them, are explained.

This work is fully illustrated and contains TWO LARGE EDUCATIONAL CHARTS, PRINTED IN COLORS.

Among the subjects treated in the book are: Beginnings of the Air Brake; Westinghouse Automatic Brake; Triple Valve; Plain Triple Valve; Function of the Triple Valve; Quick Action Triple Valve; Peculiarities and Troubles of the Triple Valve; Freight Equipment; Piston Travel; American Brake-Slack Adjuster; Westinghouse Retaining Valves; Main Reservoir; Westinghouse Engineer's Brake Valve; G 6 Brake Valve; Slide Valve Feed Valve; Feed Valve or Trainline Governor (Old Style); Engineer's Equalizing Reservoir or "Little Drum"; Westinghouse D 8 Engineer's Brake Valve; Comparison of G 6 and D 8 Engineer's Brake Valve; Westinghouse Air Pumps; Nine and One-Half-Inch Pump; Eight Inch Pump; Nine and One-Half-Inch Pump, Right and Left Hand; Eleven-Inch Pump; Westinghouse Pump Governors; The Sweeney Compressor; The Water Brake; Westinghouse Signal System; High-Speed Brake; Schedule U or High-Pressure Control; Combined Automatic and Straight Air Duplex Main Reservoir Regulation; Appliances and Methods of Testing Triple Valves; Lubricants; Air Brake Recording Gauges; Train Inspection; Train Handling; Brake Tests; Piping; Cam Brake; Braking Power and Leverage; Cylinders to be Used on Different Vehicles; American Brake Leverage; Air Hose and Specifications; Rules and Formulæ for Inspectors.

OVER 1,500 QUESTIONS WITH THEIR ANSWERS.

---

**NORMAN W. HENLEY & CO.,**  
PUBLISHERS,

132 NASSAU STREET, NEW YORK.





JUST PUBLISHED.  
22d Edition. Greatly Enlarged.

---

---

## Locomotive Catechism

---

---

OR  
How to Run a Locomotive.

BY ROBERT GRIMSHAW.

PRICE, \$2.00

**T**HIS book commends itself at once to every Engineer and Fireman, and to all who are going in for examination, or promotion.

In plain language, with full, complete answers, not only all the questions asked by the examining engineer are given, but those which the young and less experienced would ask the veteran, and which old hands ask as "stickers."

It is a veritable Encyclopædia of the Locomotive, is entirely free from mathematics, and thoroughly up to date.

It contains Sixteen Hundred Questions with their Answers.

### PARTIAL TABLE OF CONTENTS.

Definitions and Classifications ; The Boiler ; The Engine ; The Frame Running Gear ; Continuous Train Brakes ; Compound Engine ; Accidents and Emergencies ; Boiler Flues ; Boiler Attachments ; Dry Pipe and Throttle ; Steam Pipe ; Steam Chest ; Slide Valve ; Cylinder ; The Rods ; The Piston ; The Exhaust and its Signs ; Cross-head Crank Pins ; Filing, Fitting and Lining Brasses ; Compound Engines.—Containing Official Form of Examination of Firemen for Promotion and of Engineers for Employment. (143 questions answered in detail.) Many of the answers illustrated by engravings especially prepared therefor.—Nearly 450 Pages, over 200 Illustrations, and 12 Large Folding Plates.—Bound in Cloth, Price \$2.00.

---

**NORMAN W. HENLEY & CO.,**  
PUBLISHERS,

132 NASSAU STREET, NEW YORK.

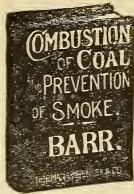

RECENTLY PUBLISHED.

---

---

A CATECHISM ON THE  
**Combustion of Coal**  
AND THE PREVENTION OF SMOKE.

---

---

A PRACTICAL TREATISE FOR

Engineers, Firemen and all others interested in Fuel Economy and the Suppression of Smoke from Stationary Steam Boiler Furnaces and from Locomotives.

By **WILLIAM M. BARR, M. E.**

**AUTHOR OF "BOILERS AND FURNACES," ETC., ETC.**  
One Volume—350 pages—85 Engravings.

**PRICE, \$1.50**

This book has been prepared with special reference to the generation of heat by the combustion of the common fuels found in the United States, and deals particularly with the conditions necessary to the economic and smokeless combustion of bituminous coals in stationary and locomotive steam boilers.

The method of treatment consists of a systematic and progressive series of questions covering every detail relating to the combustion of fuels for the purpose of generating heat; the answers to these questions are practical and direct, and to better illustrate certain subjects which could not otherwise be made clear, eighty-five engravings have been specially prepared which admirably supplement the answers to which they belong.

CONTENTS

- CHAP. I—Fuels.**  
II—Some Elementary Data.  
III—Atmosphere.  
IV—Combustion.  
V—Products of Combustion.  
VI—Heat Developed by Combustion.  
VII—Fuel Analysis.  
VIII—Heating Power of Fuels.  
IX—Steam Generation.  
X—Stationary Furnace Details.  
XI—Locomotive Furnace Details.  
XII—Chimneys and Mechanical Draft.  
XIII—Spontaneous Combustion.

---

**NORMAN W. HENLEY & CO.,**  
PUBLISHERS,  
132 NASSAU STREET, NEW YORK.



OCT 14 1903

10

LIBRARY OF CONGRESS



0 029 827 648 3