

T 353
.S88
Copy 1

Practical Problems
*in Mechanical Drawing
and Blue-Print
Reading*

STURTEVANT



PRACTICAL PROBLEMS

In Mechanical Drawing and Blue-Print Reading

By ^{W. W.} W. Sturtevant

Instructor of Mechanical Drawing
at South High School
Minneapolis, Minn.

Formerly instructor of Mechanical Drawing at the Jackson Grade
School, the Bremer Junior High School and Evening and
Part-Time Trade Classes in Minneapolis.

Copyright, 1921, by W. W. Sturtevant

Published by

PRACTICAL PROBLEMS CO.

3332 Forty-fourth Ave. S.
Minneapolis, Minn.

T 353
588

TO THE TEACHER

Much criticism has been directed at the "copy" method of teaching Mechanical Drawing and undoubtedly some pupils have copied drawings which they did not clearly understand.

The attempt, however, to make a problem of every drawing has been responsible for much poor teaching. Many boys have gained the impression that a third view was always necessary, when as a matter of fact, two views of an object gave all of the information necessary and the drawing of the third view was a waste of time. Similarly if dotted lines on a view give the pupil a clear idea of an object, the drawing of a section is poor practice.

It is suggested that the test drawing, the side view or section or sketch be made on a separate sheet in pencil, thus saving time and avoiding the possibility of the pupils receiving the impression that it must be made to complete the drawing.

Acknowledgement is here made of the many helpful suggestions of my supervisors and co-workers in the Minneapolis Public Schools in the selection of these plates.

W. W. Sturtevant.

DEC 16 1921

© Cl. A 654285



SHS 20 Jan 1952

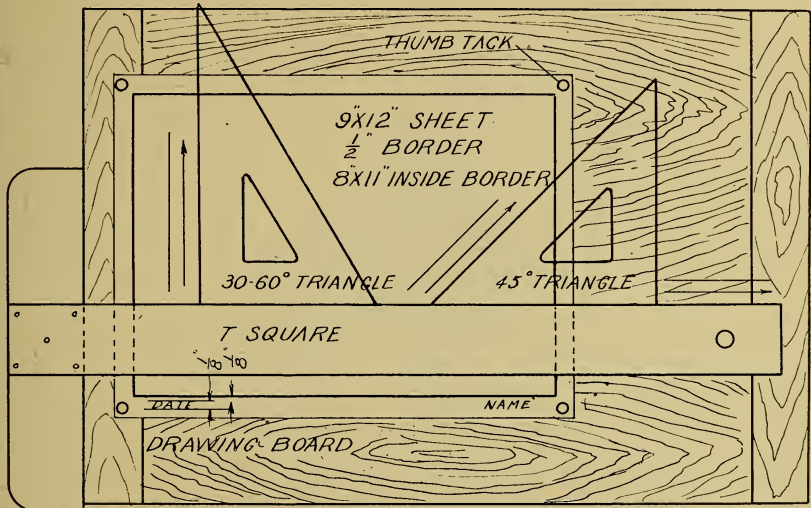

DRAW LINES IN THE DIRECTION INDICATED BY ARROWS
KEEP YOUR PENCILS SHARP. YOU MUST BE EXACT

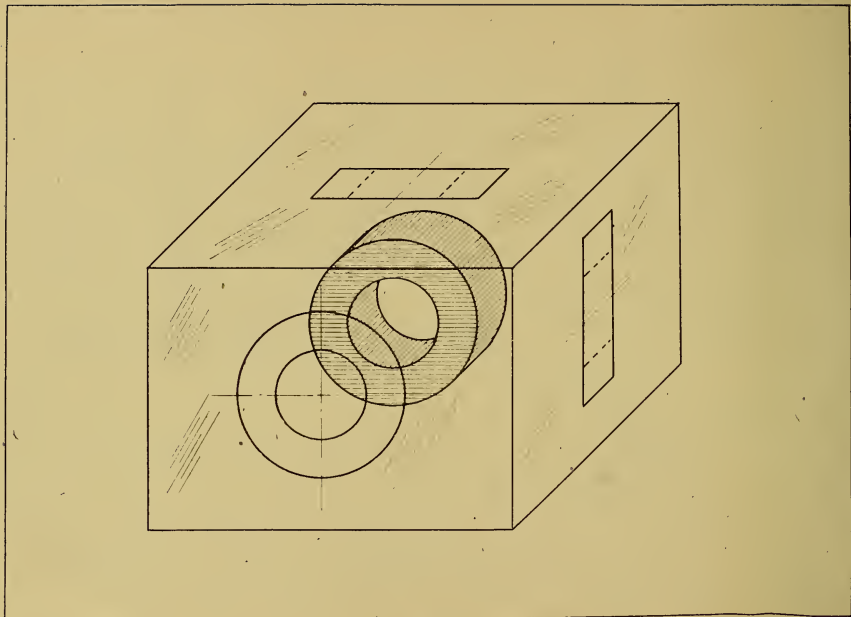

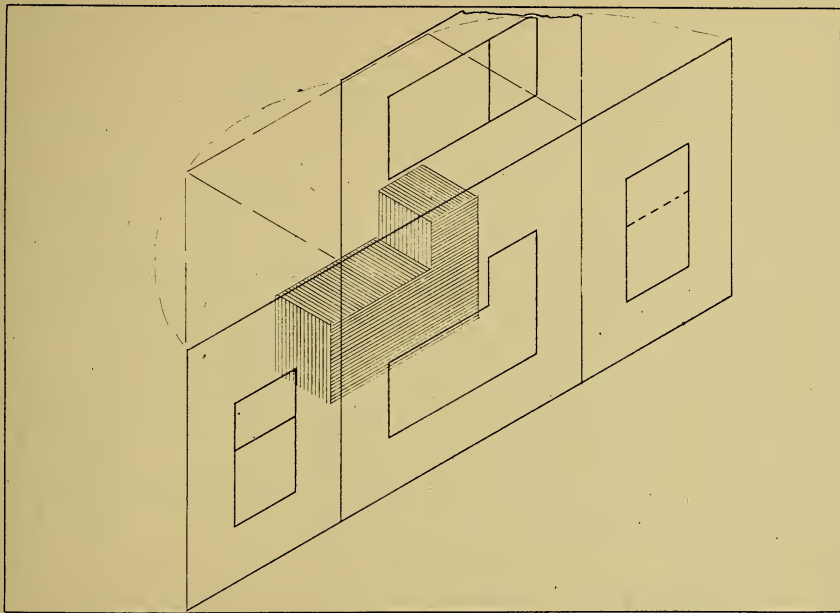

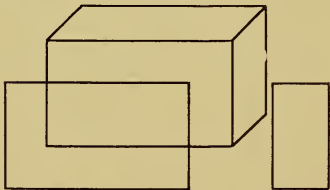
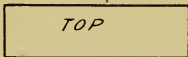
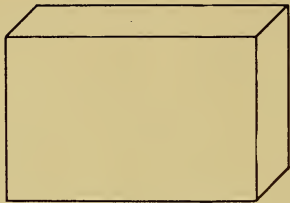

FRONT

END

TOP VIEW

FOLD BACK

*LEFT
END
FOLD BACK*

FRONT VIEW

*FOLD BACK
RIGHT
END*

CONVENTIONAL LINES

BORDER LINE

OUTLINE

INVISIBLE LINE

CENTER LINE

PROJECTION LINE

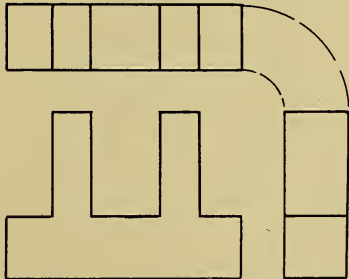
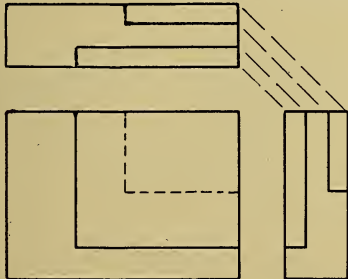
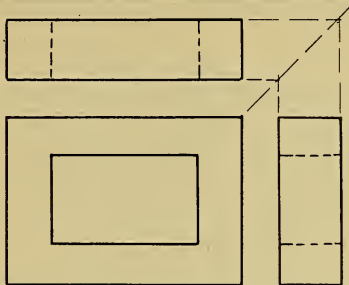

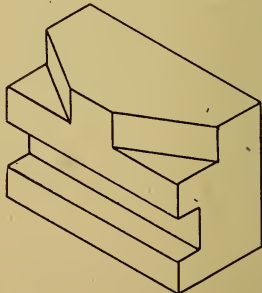
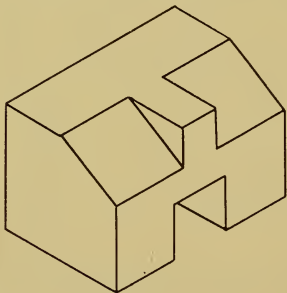
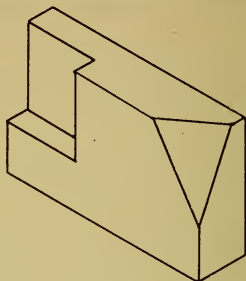
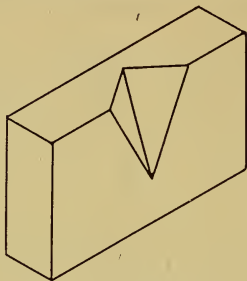

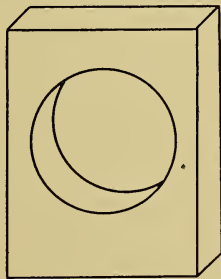
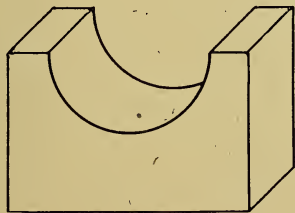
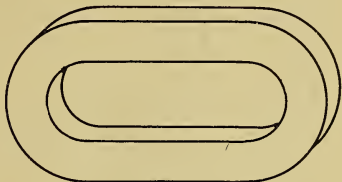
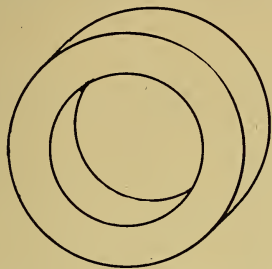

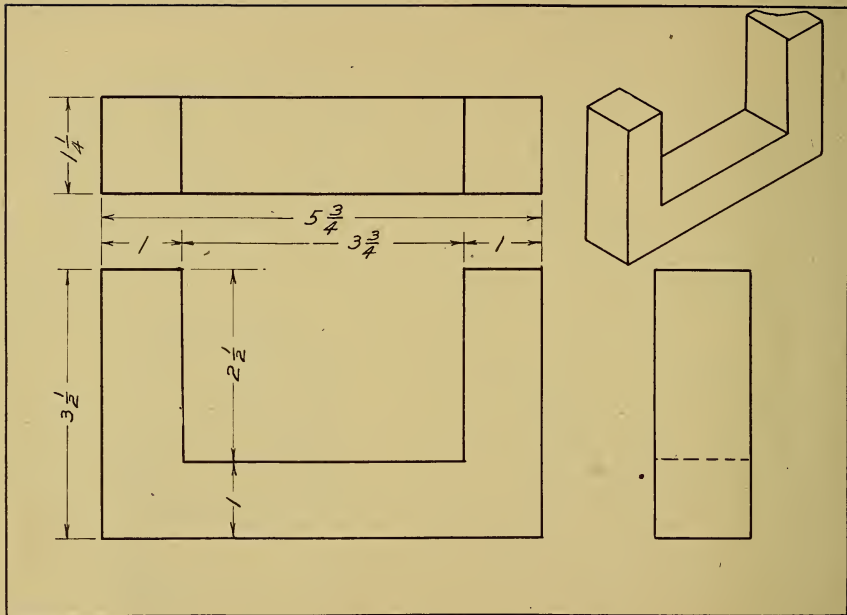

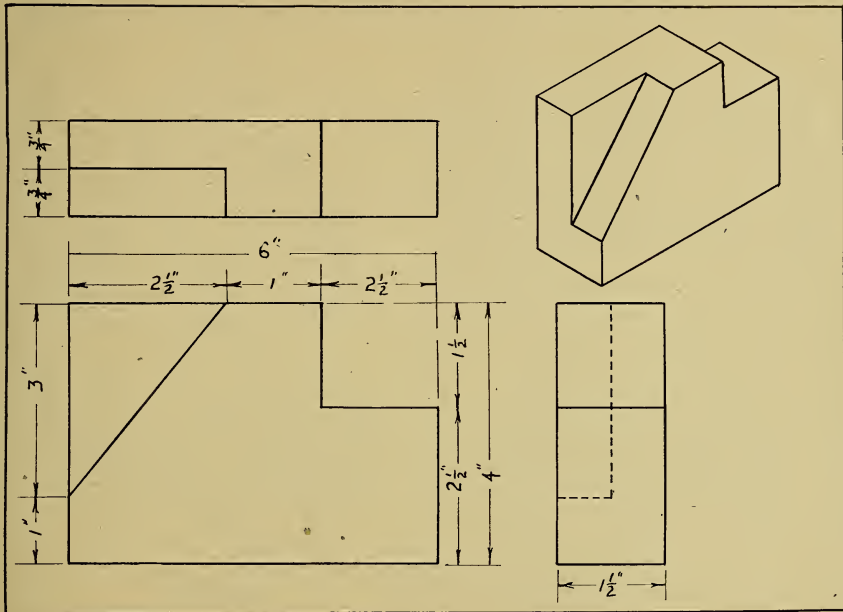

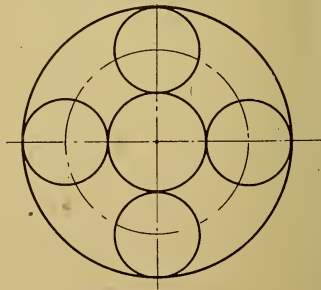
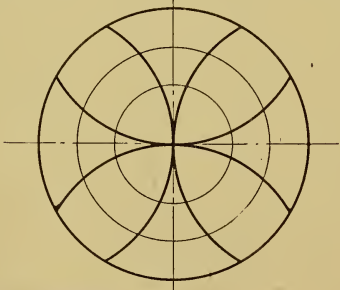
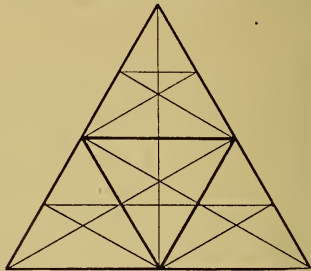
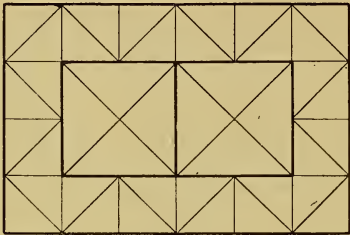

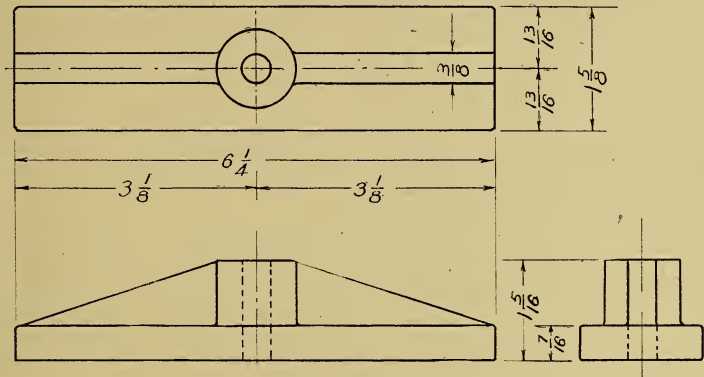

CLAMPING PAD

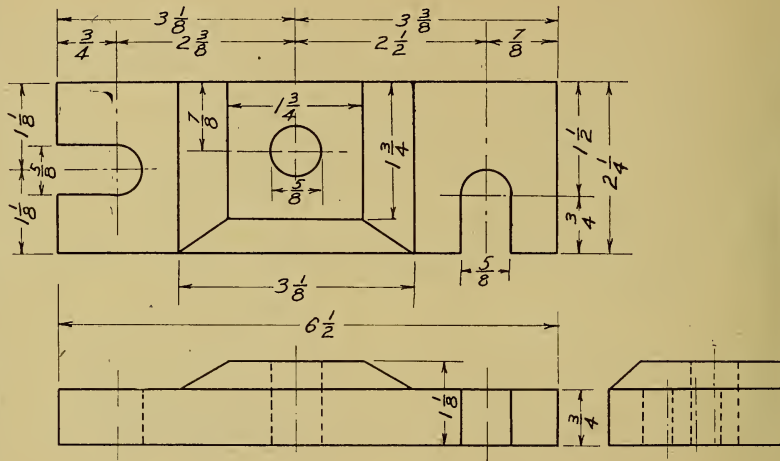

CASTING

DRAW LEFT END

TANGENTS

In the development of good technic in Mechanical Drawing there is probably no point that presents greater difficulty than the gaining of a smoothness of tangent lines and arcs.

The following plates are offered as illustrating the several different problems that confront the pupil.

The two plates showing the eight problems should be drawn by the pupil, after the usual explanation by the teacher. With these plates at hand the average boy should encounter no great difficulty in drawing any of the other plates.

The construction lines on the first two plates make clear the method of locating the center of the arc by drawing lines parallel to the straight lines and circles concentric with the circles.

The point of tangency is on a radial line

drawn perpendicular to the straight line and on a line drawn through the center of the circle and the center of the small arc.

Each boy is to draw as many of the plates as is necessary in order to develop the required skill. No pupil is to be asked to draw all of the plates, but by having at hand a number of plates the teacher may select one that meets the needs of the pupil and is within the limits of his ability.

By giving each boy his own problem much greater interest may be secured than by having the whole class draw the same plate. Also by asking boys to check the drawings made by others in the class they will learn much.

The ability to visualize may be developed by asking for the side view or the top view, which may be drawn on the same or a different sheet. If the time necessary to complete the third view is not available a free hand sketch may be substituted for this.

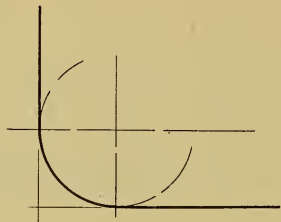

1

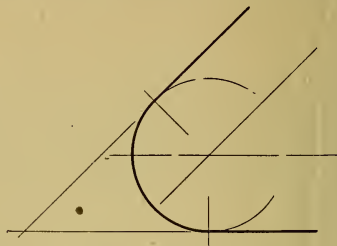

2.

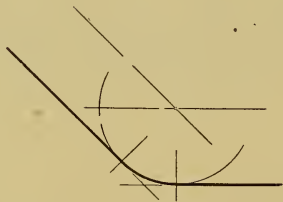

3.

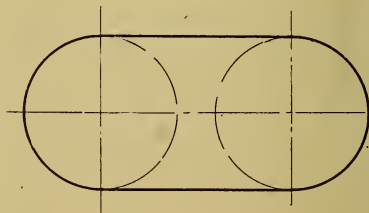

4.

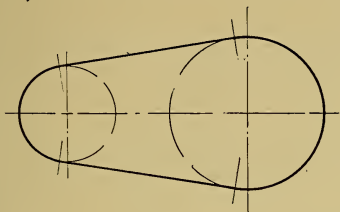

5.

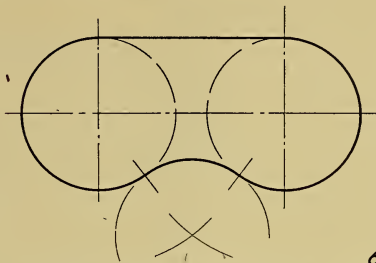

6.

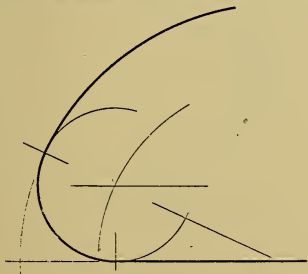

7

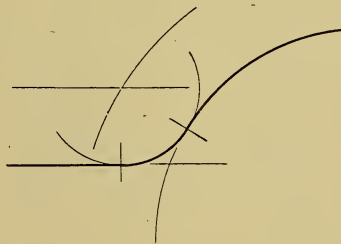

8.

$\frac{1}{2}$ " BOLTS

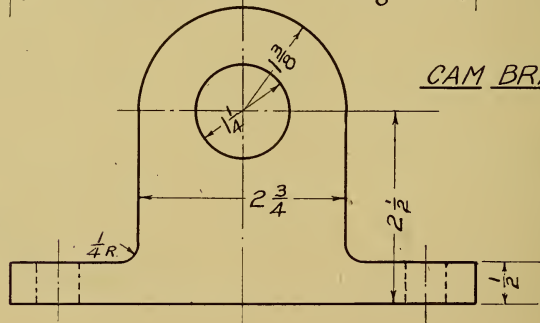
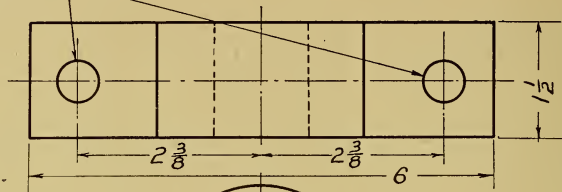

CAM BRACKET

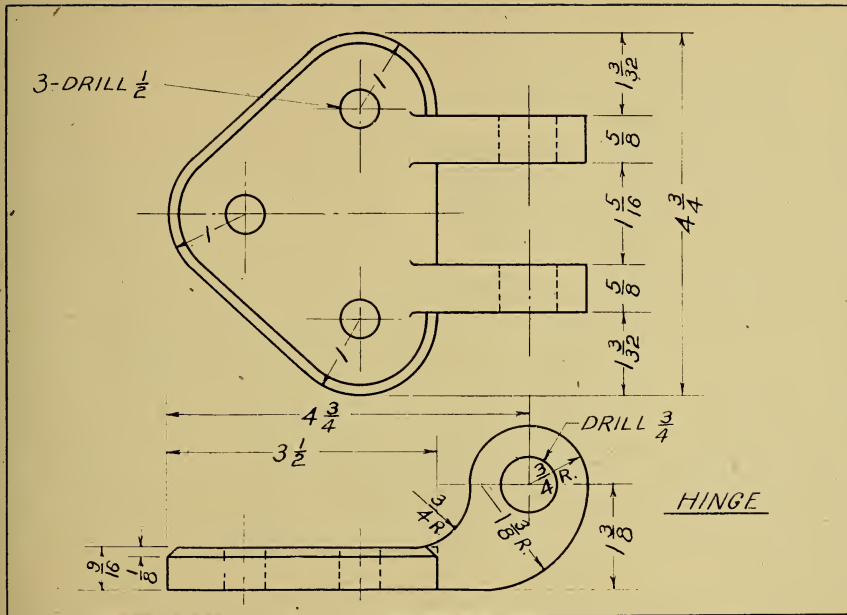

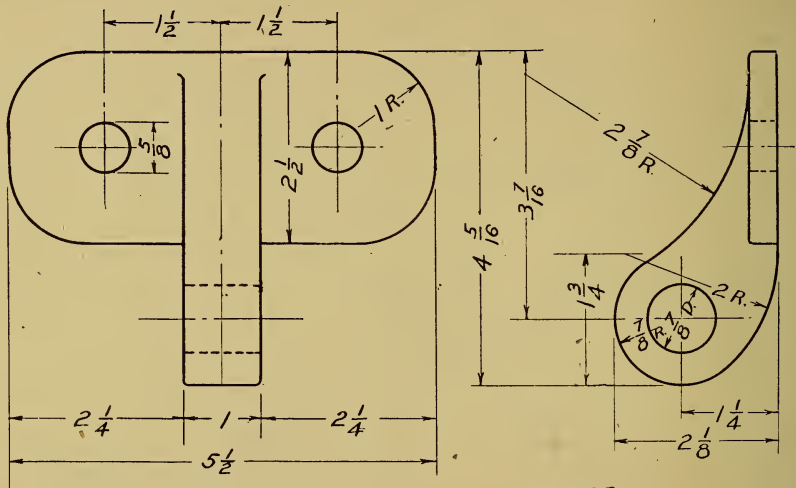

HINGE

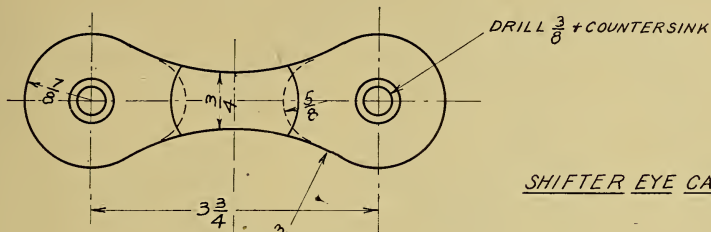

SHIFTER EYE CATCH

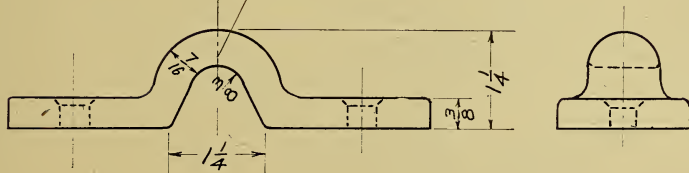

WHEEL

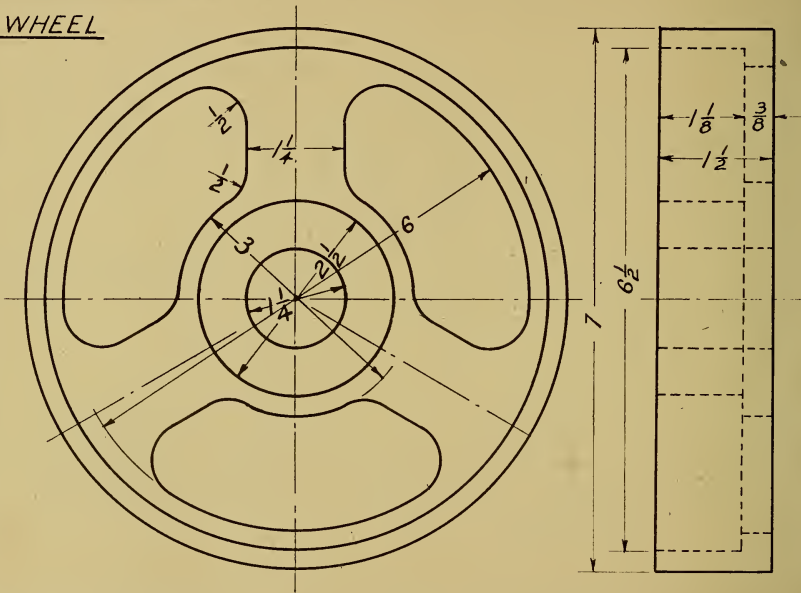

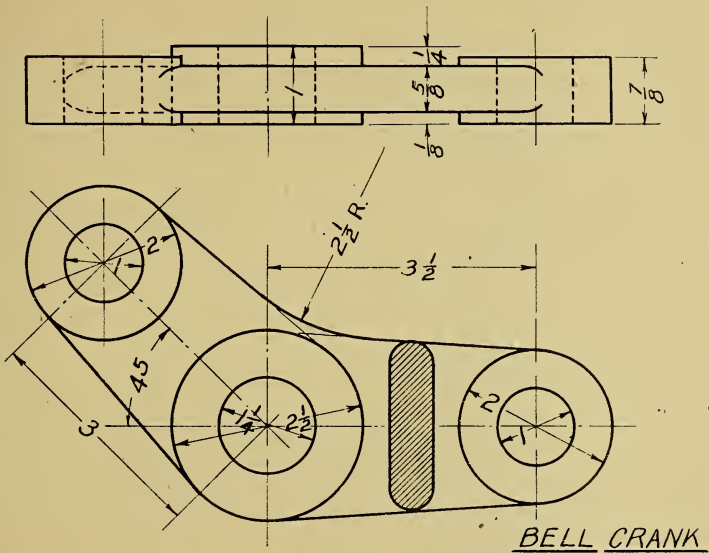

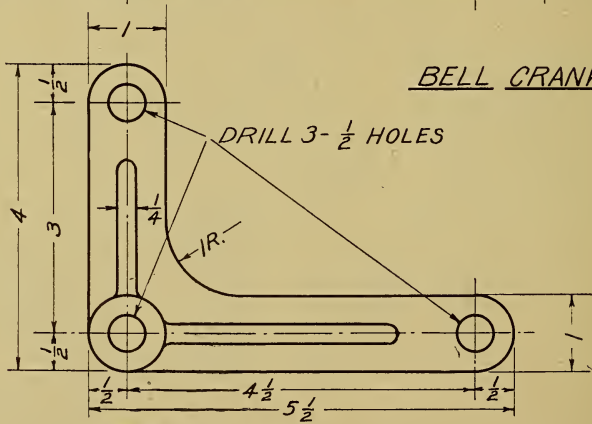
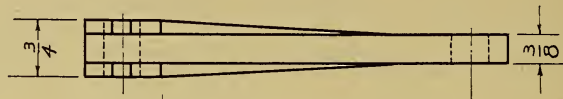

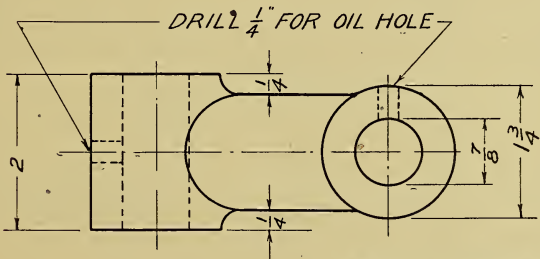
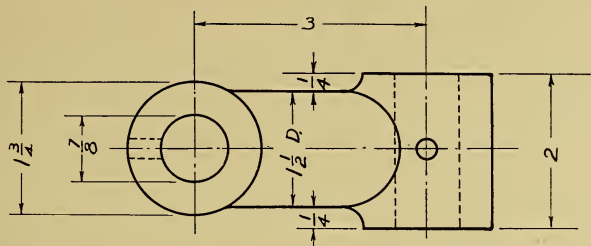

STEERING GEAR LINK

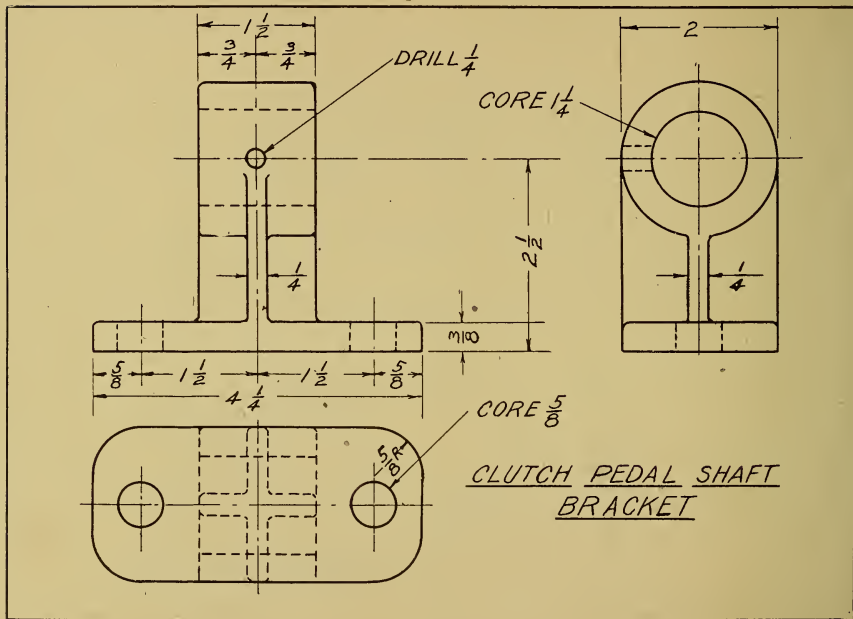

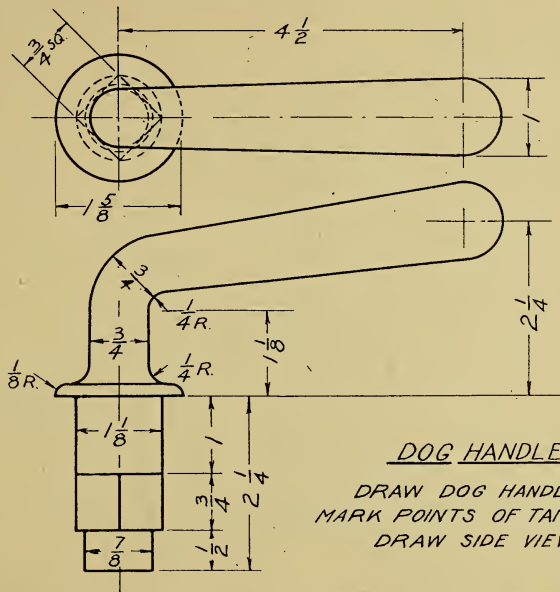

DOG HANDLE

DRAW DOG HANDLE.
 MARK POINTS OF TANGENCY.
 DRAW SIDE VIEW.

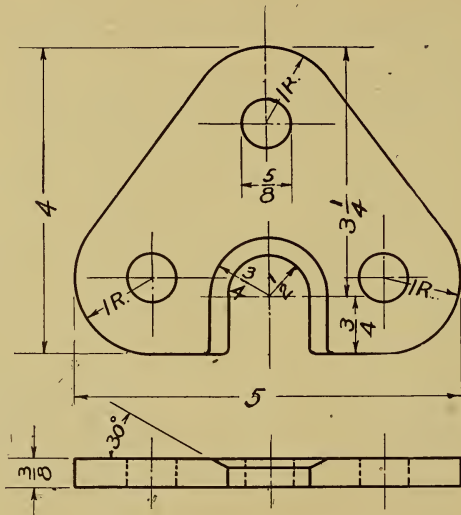

FLAT DOG

PAD EYE

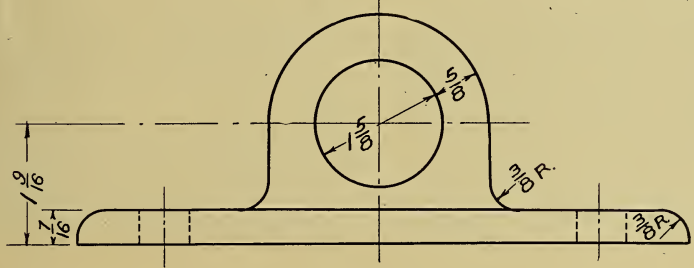
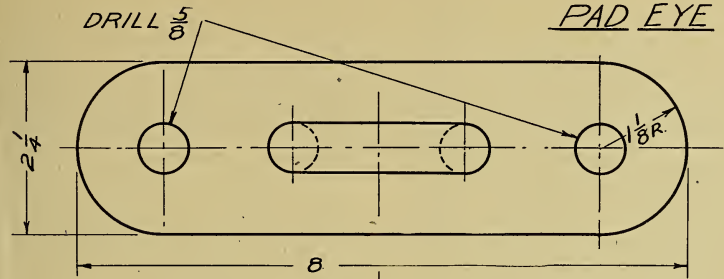

SECTIONAL VIEWS.

Frequently drawings are required of objects that because of their construction require a great number of dotted lines to show the location of hidden parts. Such drawings are usually difficult to understand. Especially is this true if the dotted lines intersect.

To add clearness, in such cases sectional views or sections are usually used. The object is drawn as though the section or part of the object nearest the observer were broken away and the interior exposed to view.

The line on which the section is taken is an imaginary plane, passing through the object, called a trace. It need not be a straight line. Any line that will show the object to the best advantage may be used. This cutting plane is purely imaginary and any sections may be drawn that in the draftsman's opinion will give added clearness.

Only one view is, as a rule, shown in section the other views of the drawing show the object complete.

On the drawing, the surfaces which are assumed to be cut are covered with light slanting

lines, known as section lines or sometimes as cross-hatching. Section lines are usually drawn at an angle of 45° but in cases where the appearance would be improved the angle may be changed. These lines should be about one half of the weight of the standard line and they should be spaced a uniform distance apart.

The spacing varies somewhat, being greater on large surfaces and less on small. Usually $1/16$ of an inch apart is about right. On a large surface $1/8$ or $3/16$ is better. Very large surfaces are frequently lined only around the edge and very small surfaces are filled in solid.

On the pencil drawing the surface to be sectioned is indicated but the section lines are drawn on the tracing or ink drawing only. Lines are spaced by the eye, no attempt is made to lay them off equal distance by measure.

Standard section lining to represent different materials are shown on page 33, but these are not in universal use. Many drafting rooms draw all materials with the same lining used for cast iron and designate the material by letters, abbreviating the name, placed on the surface to be cross-hatched.

As a shop note usually specifies the material the tedious and expensive section lining to show cast steel, wrought iron, etc., is not considered necessary.

Some draftsmen fill in sectioned surfaces with a soft pencil on the tracing. This shows clearly on the blue print and has the advantage of being very quickly done.

Some exceptions to the rules governing drawing are made on sectional views. These conventions are listed below.

Dotted lines showing invisible lines back of a section may be drawn in or omitted as desired.

Spokes are never drawn in section. The drawing is made as though the cutting plane passed in front of the spoke. This makes clear the difference between wheels having spokes and those cast solid.

Webs are not drawn in section. Webs are sometimes sectioned as in page 39. By omitting alternate lines the web is made easy to distinguish.

Objects that are symmetrical about an axis are usually drawn one half in section.

Unsymmetrical objects, as wheels with 3 or

5 spokes, are drawn as though they were symmetrical.

Adjacent surfaces of different pieces are sectioned in a different manner or with lines drawn at a different angle.

The draftsman must use his judgment as to the number of sectional views that are necessary. Sometimes three or four sections are necessary. Again a revolved section of a very small part is all that is needed.

Often the shape of a spoke or a web or similar small part of an object may be shown by what is called a revolved section. This section is placed on the regular view.

The pupil should bear in mind the fact that a section takes more time and therefore costs more than the drawing of a side view, and should be used only when the added clearness gained will warrant the extra time necessary in the drafting room.

Solid cylindrical objects, like bolts or shafts, are not drawn in section.

Removed sections are sections drawn in some convenient place on the sheet, out of their natural position.

Partial sections are used when a section of a small part of an object will show all that is necessary.

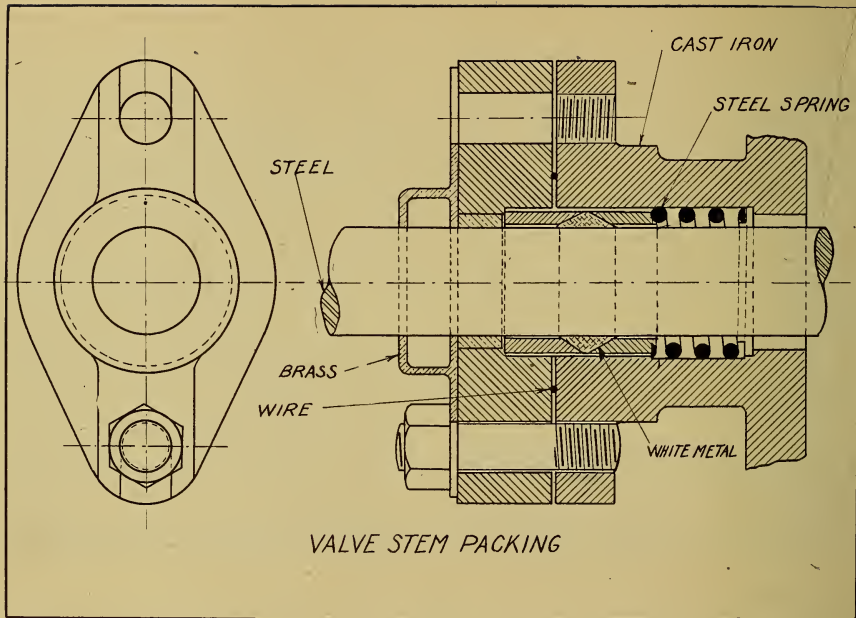



CAST IRON



WROUGHT IRON

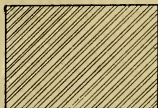

STEEL

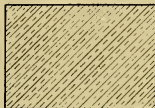

BRONZE



WROUGHT STEEL

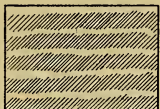

COPPER



BABBET

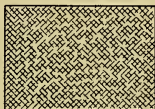

ZINC

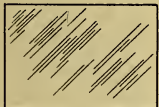

GLASS



RUBBER

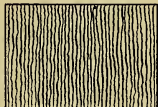

LEATHER

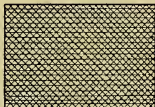

WIRE



WOOD

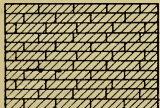

BRICK

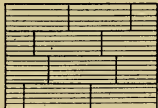

STONE



WATER

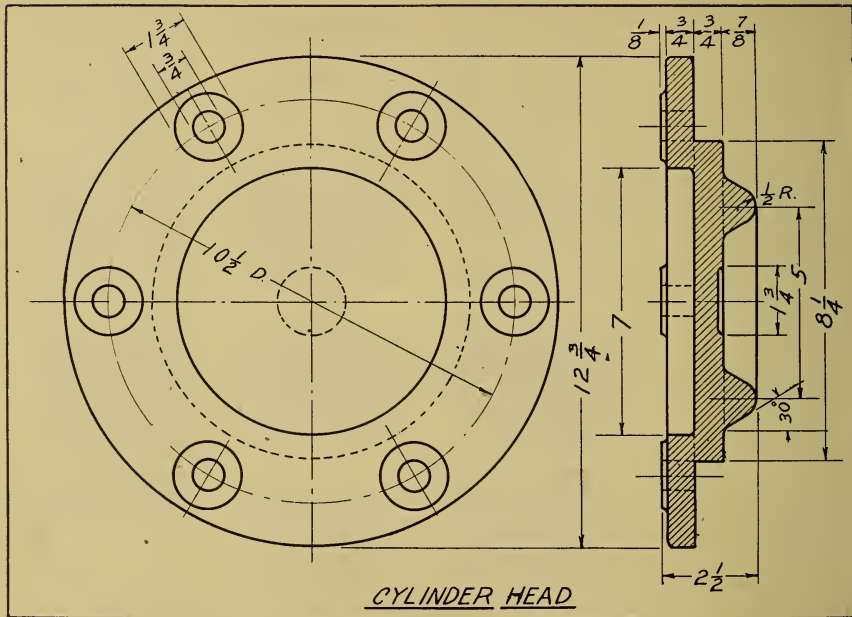

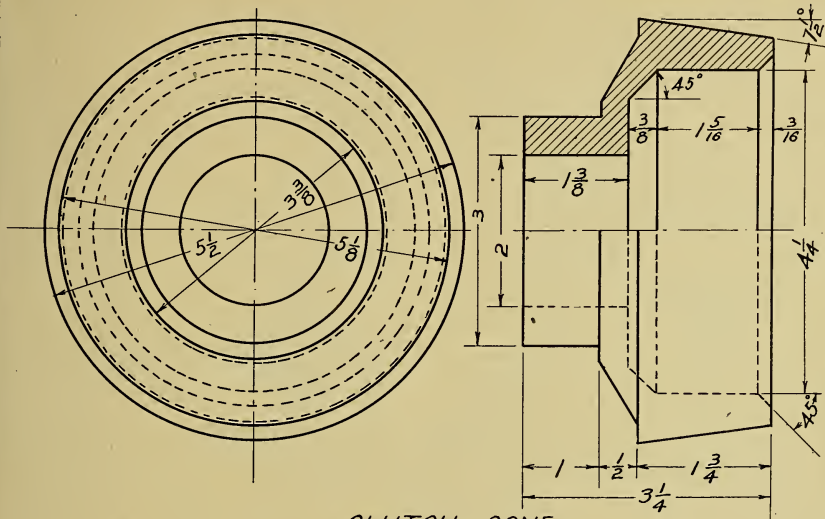

CLUTCH CONE

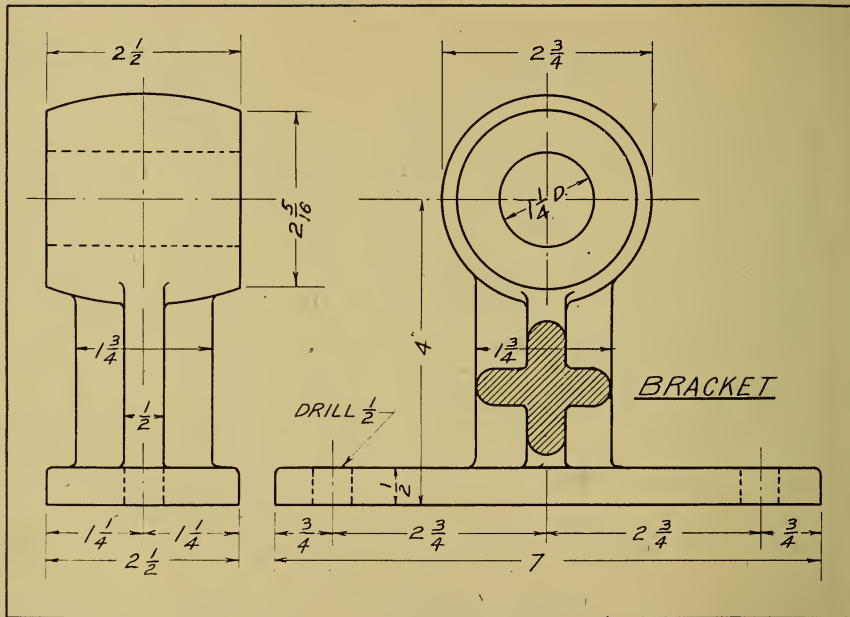

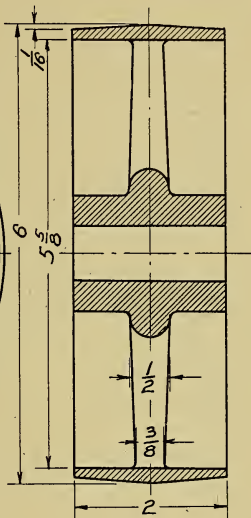
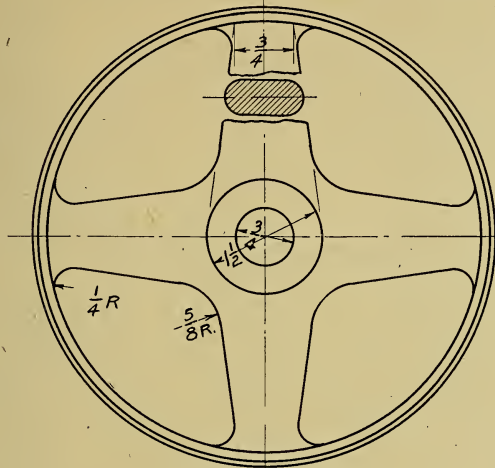

PULLEY

SECTION THROUGH SPOKE

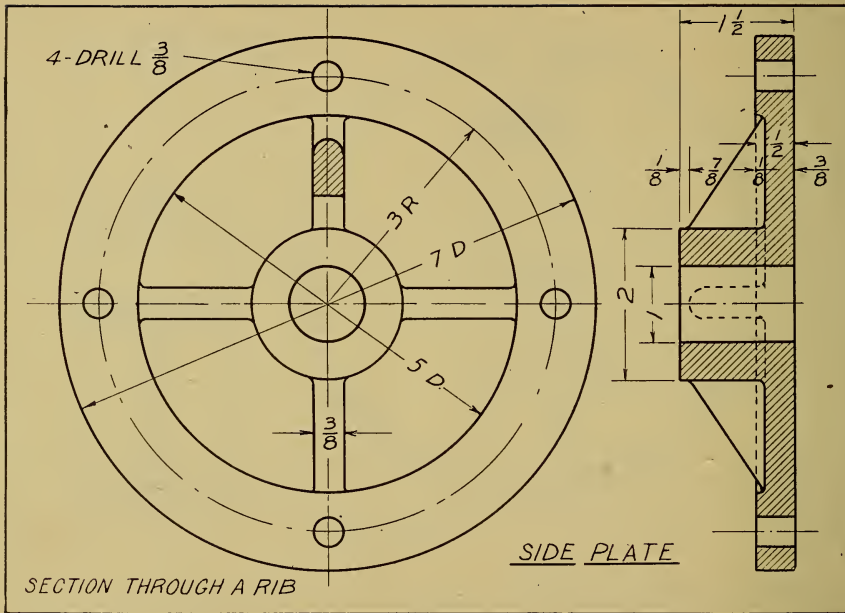

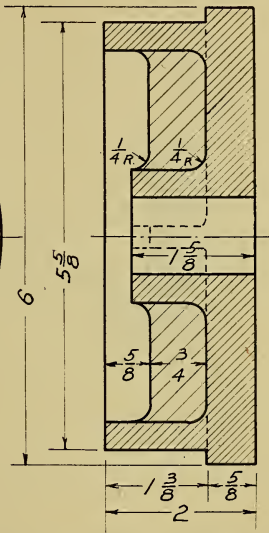
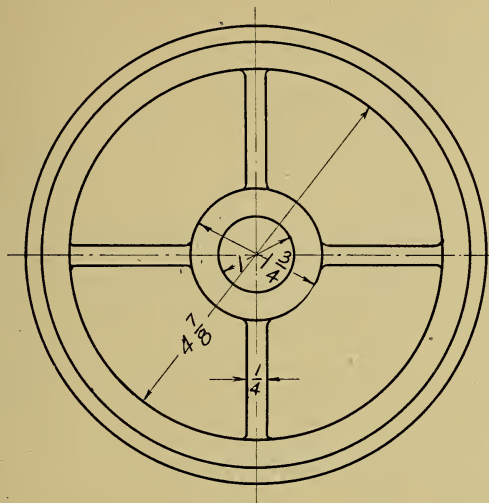

ROLLER END

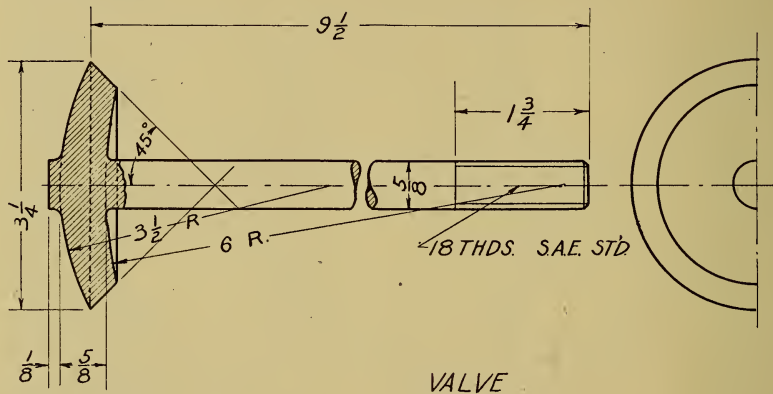

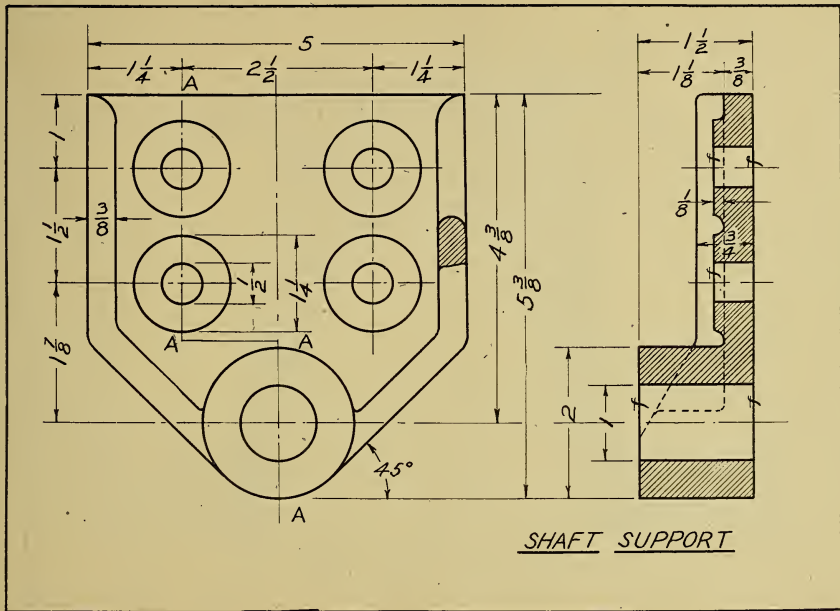

SHAFT SUPPORT

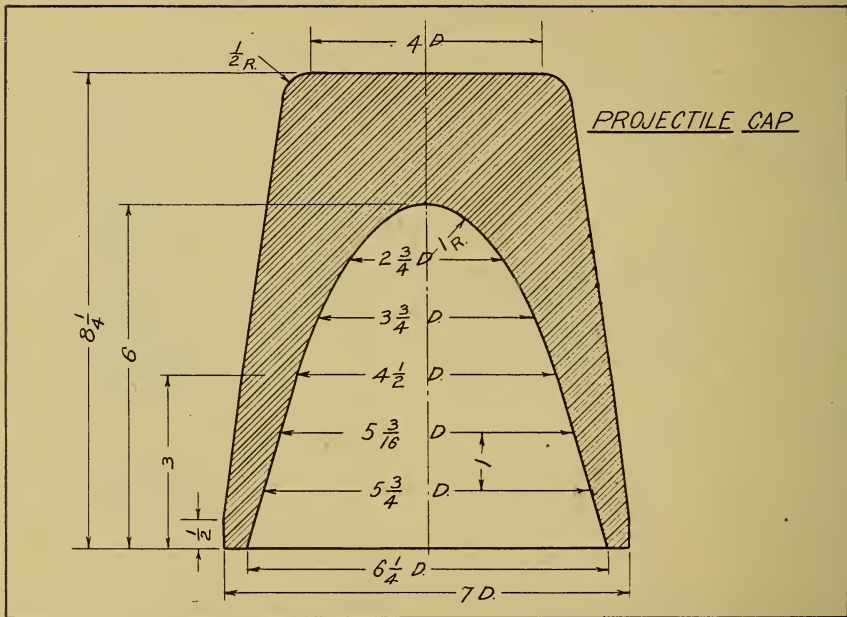

COMMUTATOR CAP

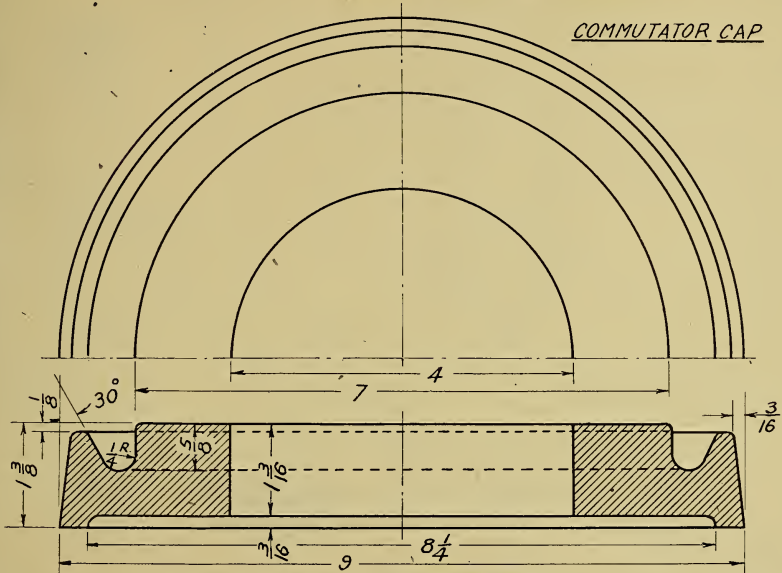

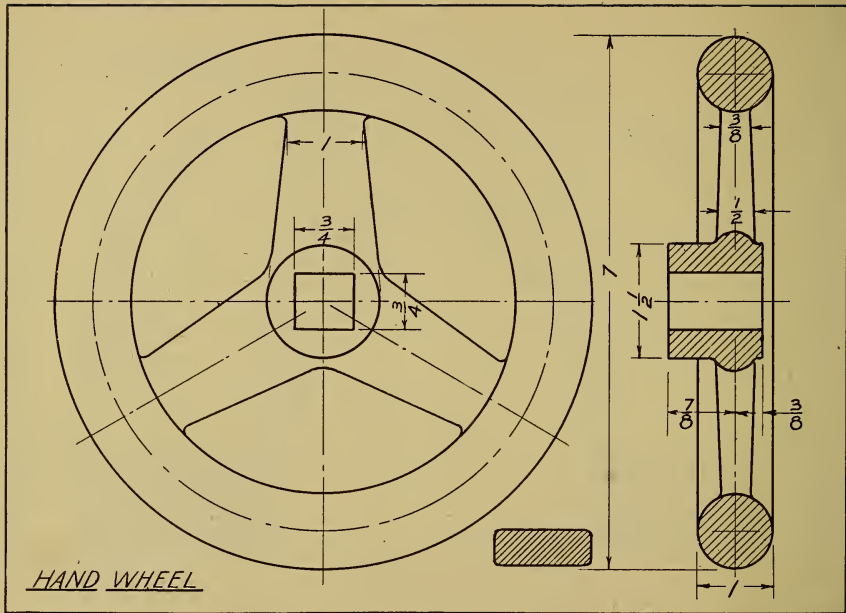

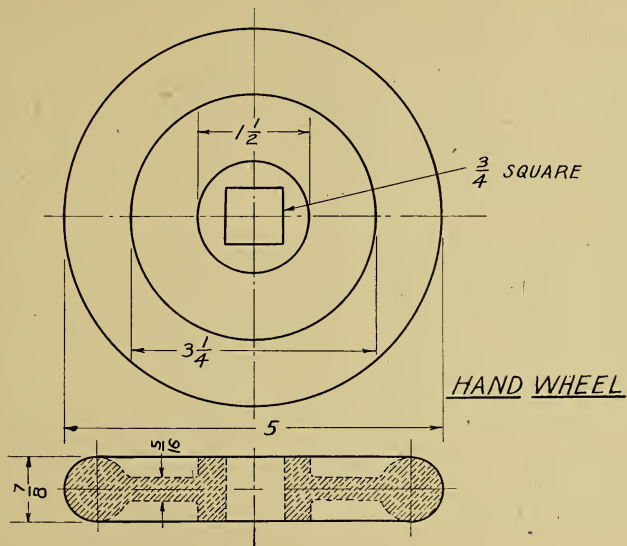

DOTTED SECTION

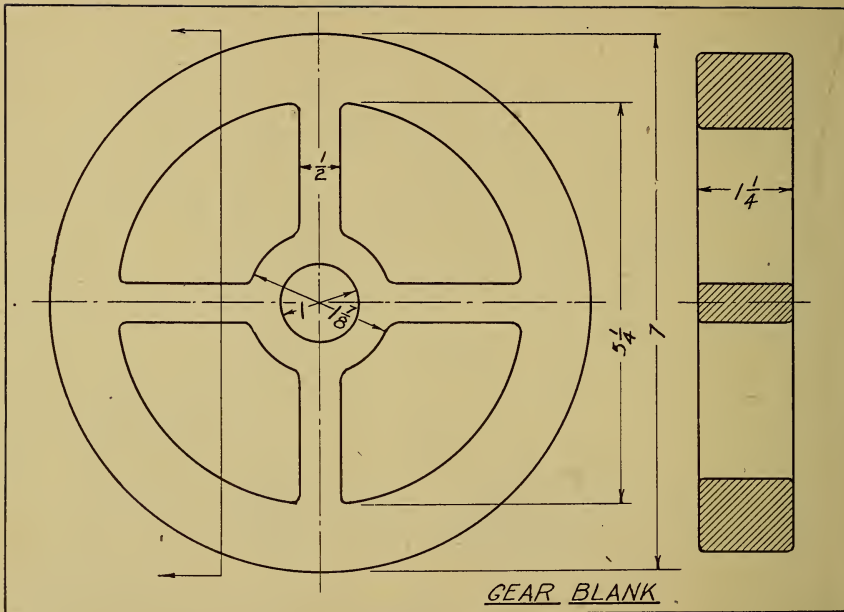

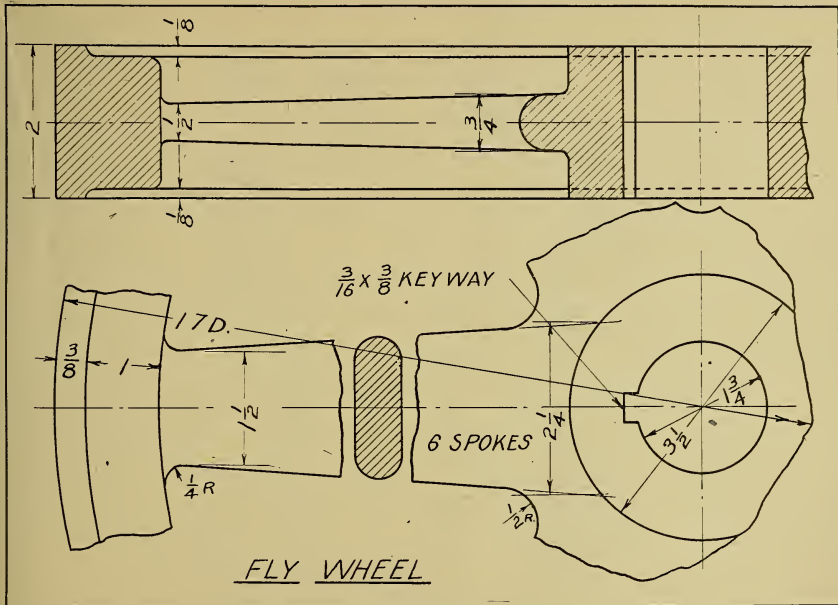



SEC. A-A

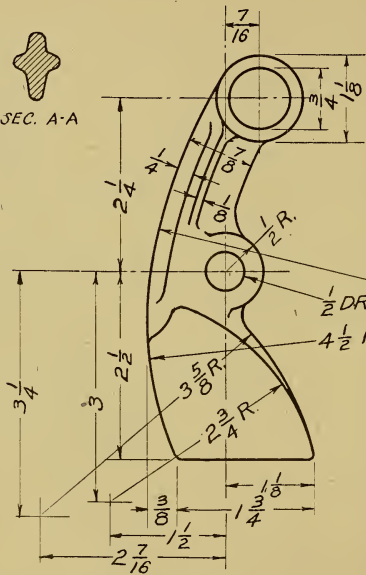

SEC. B-B



SEC. C-C

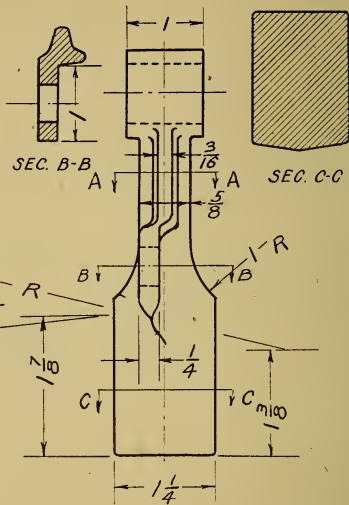

WEIGHT

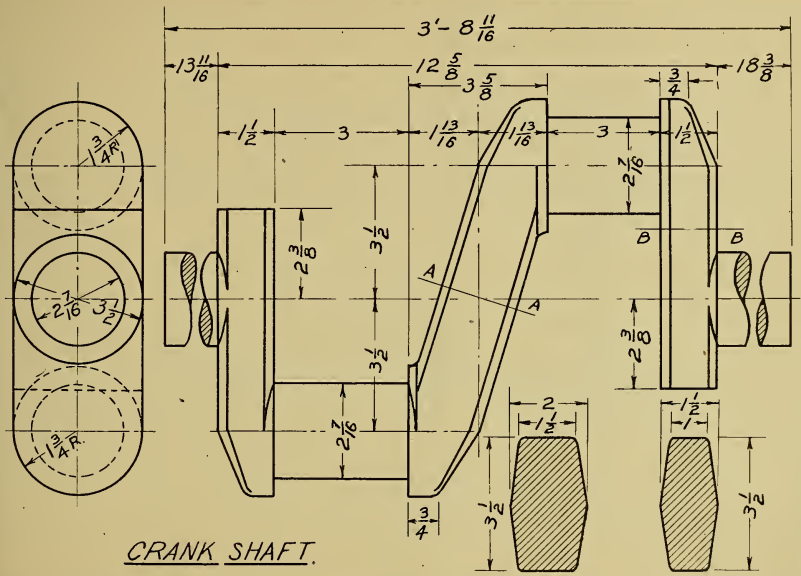

CRANK SHAFT.

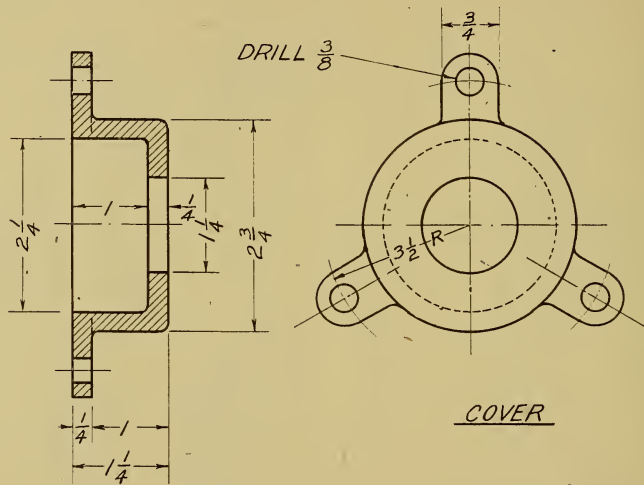

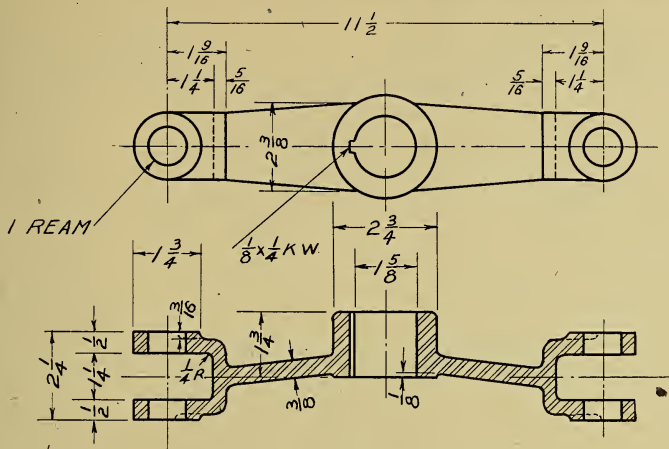

1 REAM

$\frac{1}{8} \times \frac{1}{4}$ KW

$\frac{1}{4}R$

CLUTCH SPIDER

FLY WHEEL

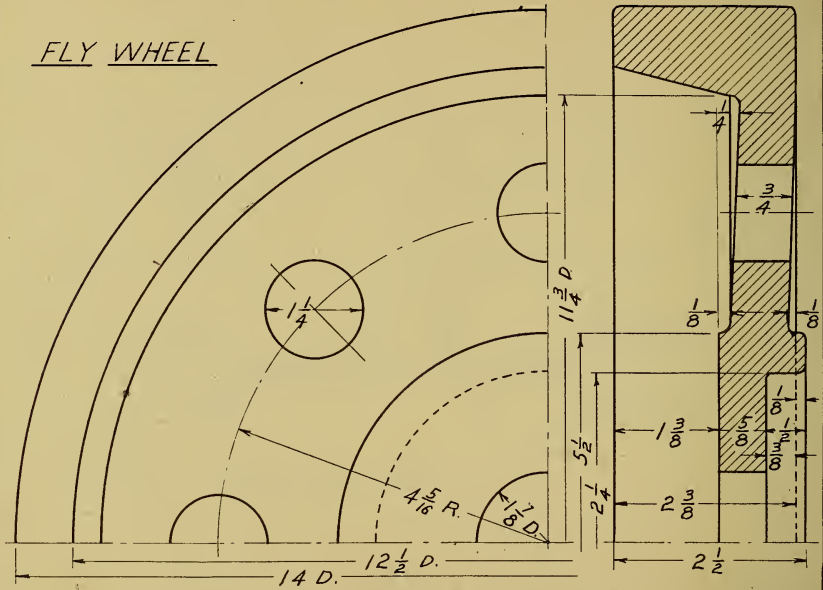

CONE PULLEY

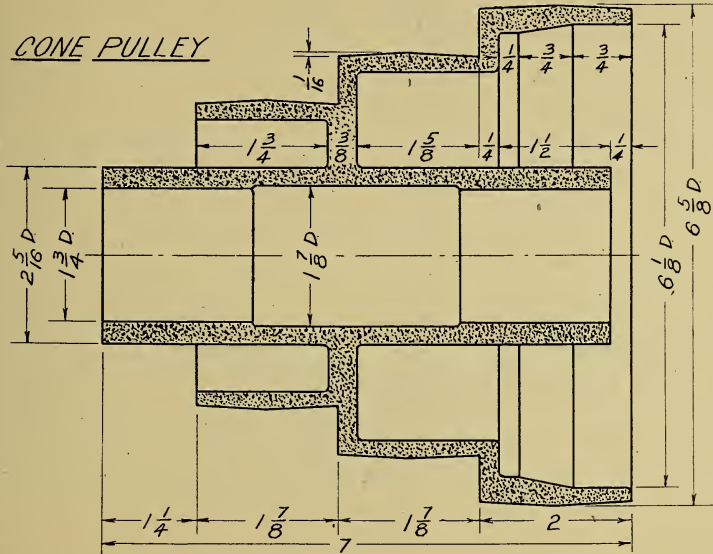

SPARK LEVER

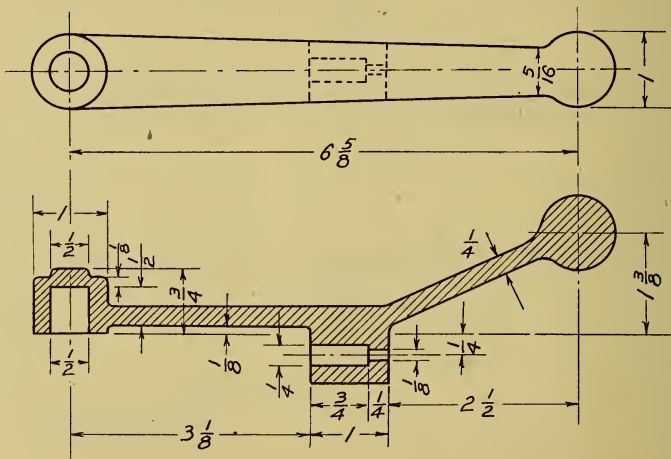

AUXILIARY VIEWS

Auxiliary views are used when it is necessary to show the true length of a slanting surface that would appear fore-shortened in the top or side view.

The center line of the auxiliary view is drawn parallel to the surface to be shown in this view.

DIMENSIONS

The dimensions on a drawing are of the utmost importance and the correct selection of the dimensions to be given and the proper placing of these dimensions requires good judgment and a considerable knowledge of shop practice.

Without the dimensions the drawing is of little or no value. It shows the shape of the object but the exact sizes are necessary before it is of value to the workman.

To dimension a drawing properly the draftsman should be familiar with the methods and machines used by the mechanic who is to make the object he is drawing, as this knowledge will enable him to give the information in the best way and may save the mechanic much annoyance.

The following are some general rules which it is well to follow, but it must be borne in mind that there are exceptions to all rules and if

added clearness or a saving of time will result one should not hesitate to violate any of them.

Dimension lines should present a sharp contrast to the lines of the drawing. They are usually made about one half the weight of the standard line. Most draftsmen use a continuous light line with a space left near the center for the figures. Some use a line made up of long dashes about $1\frac{1}{4}$ to $1\frac{1}{2}$ inches long separated by a small space.

Red ink is sometimes used for center lines. This makes a contrast on the blue print as the red lines print very light. If red ink is used the figures and the arrow heads are made in black ink.

Sharp arrow heads are placed at the ends of the dimension lines. Arrow heads should be about $\frac{3}{16}$ of an inch in length and $\frac{3}{32}$ of an inch in width at the wide end.

In structural work figures are sometimes placed above the dimension lines instead of in a space left for them near the center of the line.

Extension lines are the same weight as the dimension lines or about one half the weight of the outline. They should not touch the drawing. A space of about $\frac{1}{8}$ of an inch should be left between the end of the extension line and the part of the drawing to be

dimensioned. The extension lines should extend about $\frac{3}{16}$ of an inch beyond the arrow heads of the dimension lines.

The dimensions that appear on a drawing should be those of the object regardless of the scale of the drawing.

Figures should be plain and not too small. A common mistake of beginners is to confuse minuteness with neatness. Figures should be neat but not smaller than $\frac{1}{8}$ of an inch in height.

From $\frac{3}{16}$ to $\frac{1}{8}$ of an inch is good size. Do not use fancy figures. Plain readable figures that allow of no mistake are best.

Dimensions should be given in the fractions of an inch that are given on the machinists' scale, halves, fourths, eighths, etc., to sixty fourths. Other fractions should be given in decimals as 1.33" or 2.23". In some drafting rooms decimals are used entirely.

It is customary in many drafting rooms to give a limit of accuracy, as 4. — .003, meaning that the finished object may exceed 4 inches by not more than $\frac{3}{1000}$ of an inch.

4. — .005 means that the object may be $\frac{5}{1000}$ smaller, but no larger.

4. \pm .003 would indicate that the finished piece might be either $\frac{3}{1000}$ larger or $\frac{3}{1000}$

smaller, but must not exceed that limit.

Fractions should be made with the line between the numerator and the denominator horizontal, not slanting. Thus $\frac{1}{4}$, not $\frac{1}{4}$. The slant line allows the possibility of a mistake, as in $1\frac{5}{16}$ or $15/16$.

Dimensions should, if possible, be kept off of the drawing and placed at the side or between views. A good drawing should stand out clearly and each dimension line placed on it adds to the confusion.

Give the diameters of circles and the radii of arcs. Diameters should be followed by the abbreviation, Diam., Dia., or D.; radii, by Rad. or R.

Diameters are usually given for circles because a round object is usually turned on the lathe and the workman will measure with calipers. If the radius is given on the drawing, he must multiply that by two and might make a mistake.

Holes are drilled with drills marked according to their diameters, as $\frac{1}{2}$ ", 1", etc.

Arcs are laid out with the compasses or dividers and the workman must use the radius.

Never place dimensions on a drawing so that it is necessary for the shop man to make calculations. Do not ask him to add several dimensions in order to get the total. Do not

ask him to subtract in order to find the size of a part. The place for calculations is in the drafting room. Give all necessary dimensions.

Do not duplicate dimensions. Frequently it is convenient to change one or two dimensions on a drawing and thus save making a new drawing. In such cases, if dimensions appear in more than one place, one may be changed and the other overlooked.

Figures should read at right angles to dimension lines.

Figures should read from the bottom or right of the sheet. Never place figures so that they read from the top or left of the sheet.

Dimensions on diagonal lines should change at 60° .

Dimension from center lines and from finished surfaces.

Use notes freely when by so doing you can save time.

Dimensions up to two feet should be given in inches; over that distance in feet and inches.

Dimensions for the sheet metal shop are all given in inches.

The sizes of wheels, gears, pulleys, and cylinder bores; the stroke of pistons and the length

of wheel bases are usually given in inches.

Keep dimensions off of sections, if possible.

Never use center lines as dimension lines.

Never place dimensions on lines of a drawing.

When it is desired to dimension small spaces where figures would appear crowded, the figures may be placed outside of the space.

The dimensions of angles are given on a line drawn with the compass set at the vertex of the angle.

BLUE-PRINT READING

Blue-print reading, properly taught, should give the pupil three things; first the ability to make a free-hand working drawing, second the ability to make perspective sketches and last and most important the ability to visualize.

This is more likely to be of value than the ability to make Mechanical Drawings as many more boys will be engaged in work, where they will be required to read drawings, than will go into the drafting room.

It is suggested that the pupil be asked to study the drawing and then, by means of a sketch or a clay model give expression to his idea of the shape of the object.

A few lessons in Cabinet and Isometric Drawing should precede the work in Perspective Drawing.

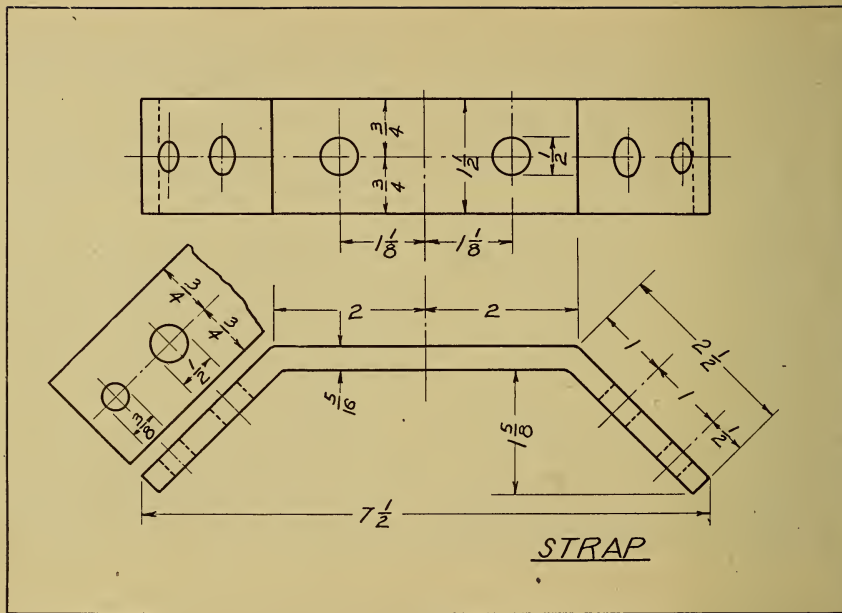

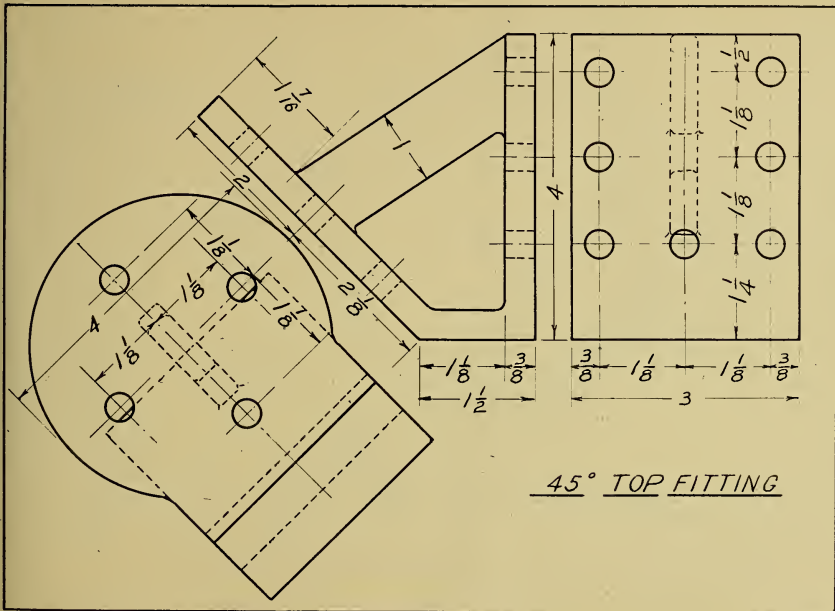

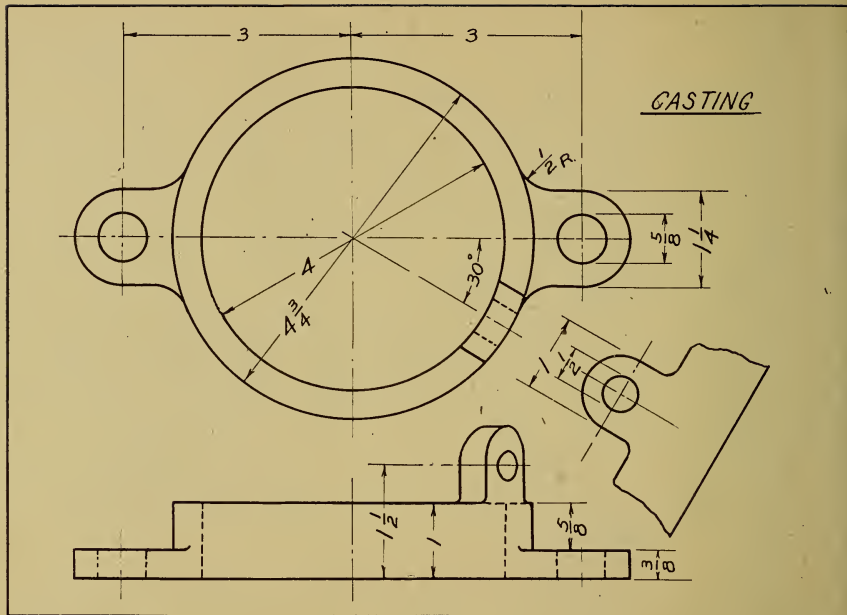

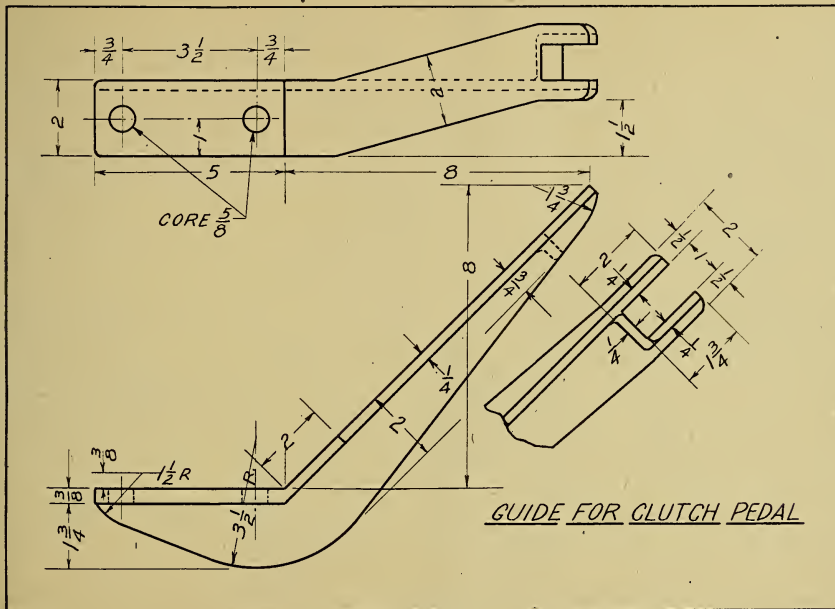

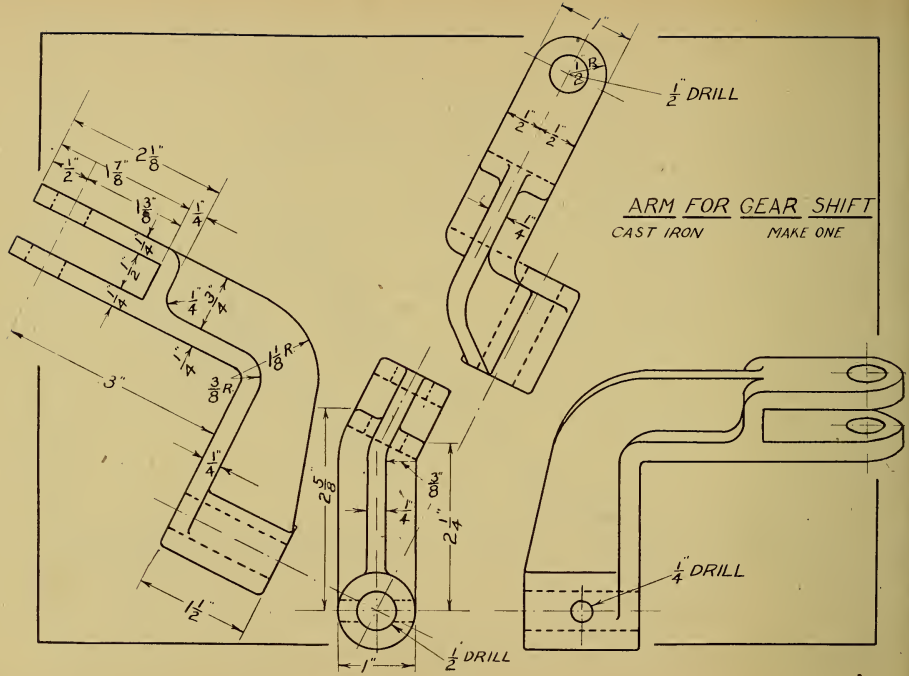

ARM FOR GEAR SHIFT
 CAST IRON MAKE ONE

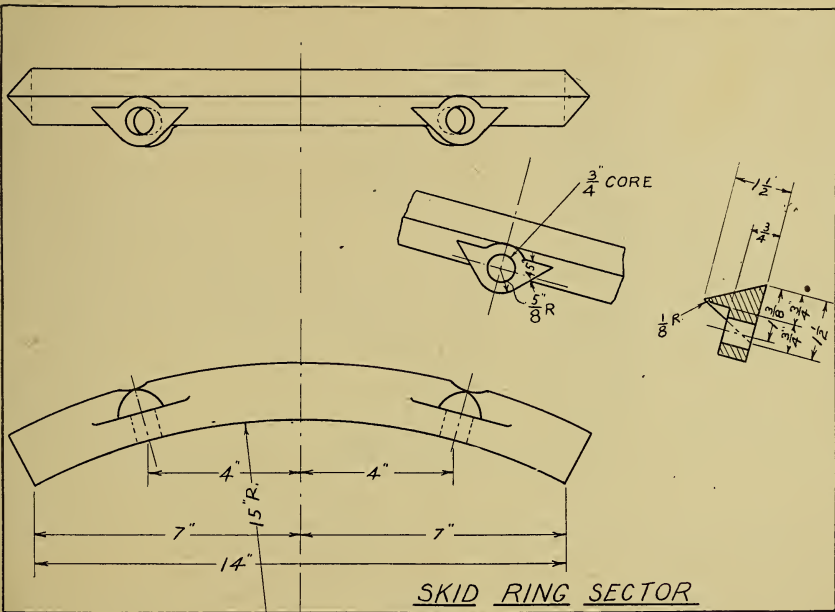

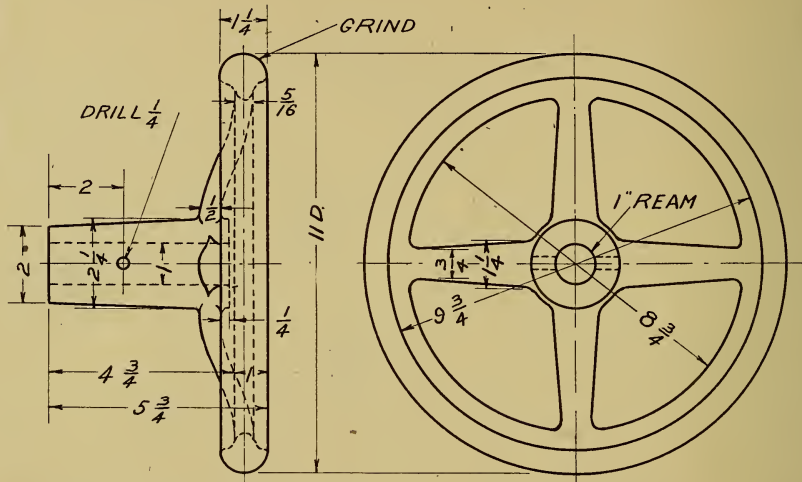

DRAW HAND WHEEL $\frac{1}{2}$ SIZE.
 MAKE DRAWING $\frac{1}{2}$ OF THE
 DIMENSIONS BUT PUT IN FIGURES AS THEY ARE HERE.

HAND WHEEL

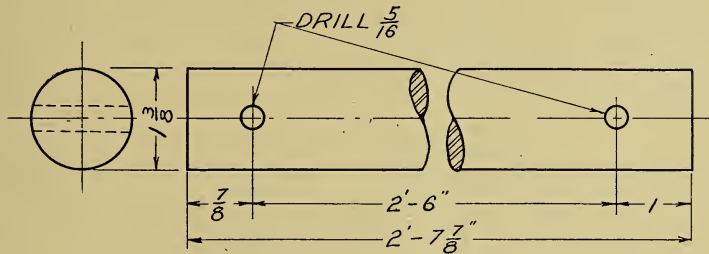

STEERING ROD

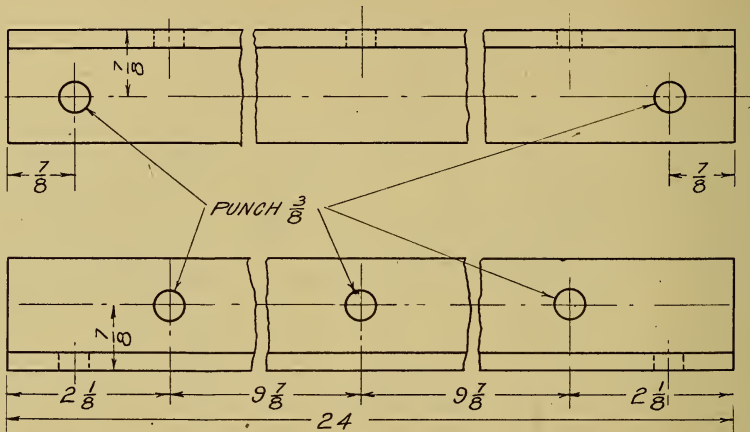

$1\frac{1}{2} \times 1\frac{1}{2} \times \frac{1}{4}$ L-STR'L STEEL

SHIELD SUPPORT ANGLE

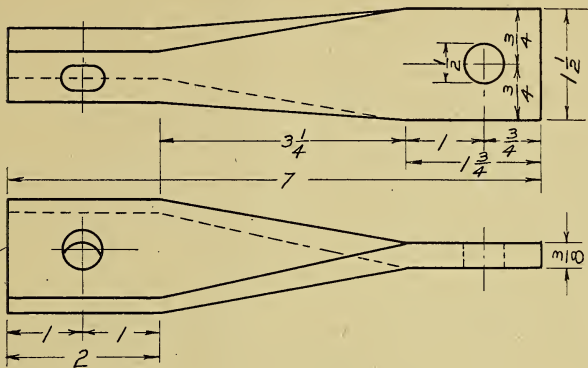
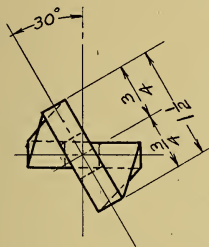

GEAR GUARD SUPPORT

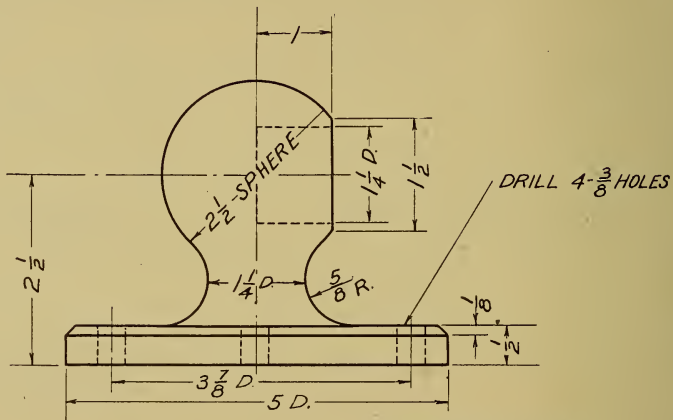

HAND RAIL KNOB

LEVER END

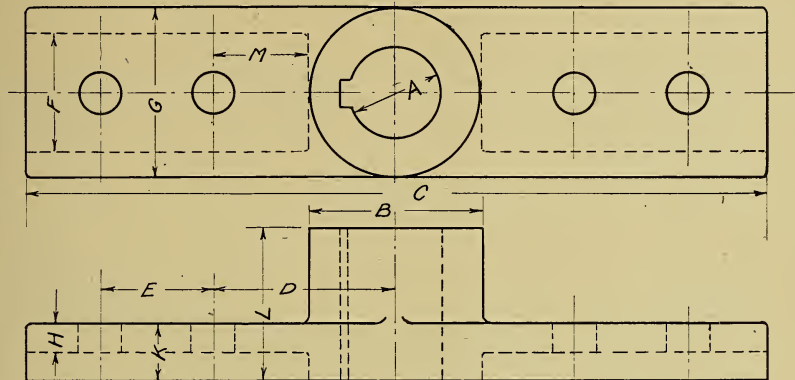

A	B	C	D	E	F	G	H	K	L	M	BOLTS
$\frac{15}{16}$	$\frac{1}{8}$	$7\frac{3}{4}$	$\frac{1}{8}$	$\frac{1}{4}$	$1\frac{5}{16}$	$\frac{1}{8}$	$\frac{1}{4}$	$\frac{9}{16}$	$1\frac{1}{2}$	$\frac{7}{8}$	$\frac{3}{8}$
$1\frac{3}{16}$	$2\frac{1}{4}$	$9\frac{3}{4}$	$2\frac{3}{8}$	$1\frac{1}{2}$	$1\frac{9}{16}$	$2\frac{1}{4}$	$\frac{3}{8}$	$\frac{3}{4}$	2	$1\frac{1}{4}$	$\frac{1}{2}$
$2\frac{7}{8}$	5	15	$3\frac{1}{2}$	$2\frac{3}{4}$	$2\frac{9}{16}$	$3\frac{13}{16}$	$\frac{1}{2}$	1	3	$1\frac{1}{4}$	$\frac{5}{8}$

STEERING GEAR CONNECTION

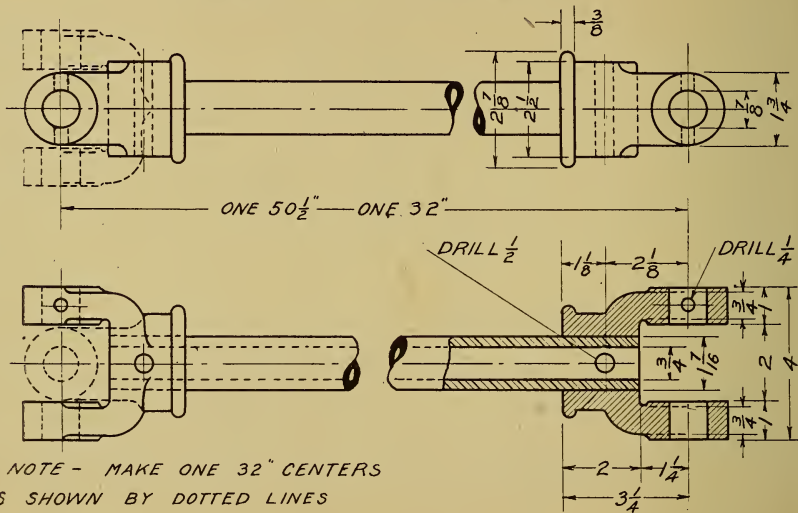

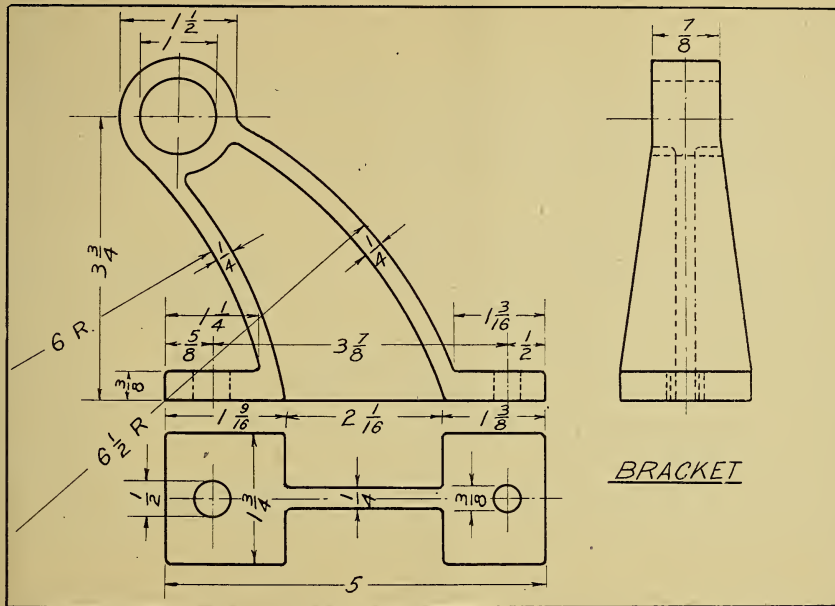

BRACKET

SPECIFICATIONS:-15 TO 25 CARBON

ROUGH TURN TO 1.265" & AFTER HARDENING GRIND $1\frac{1}{4}$ " DIA. $\pm .0005$

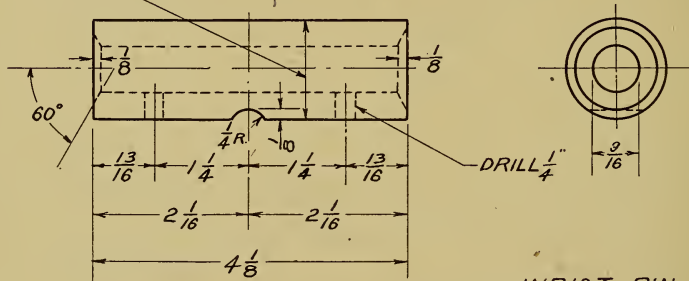

WRIST PIN
MILD STEEL MAKE 4

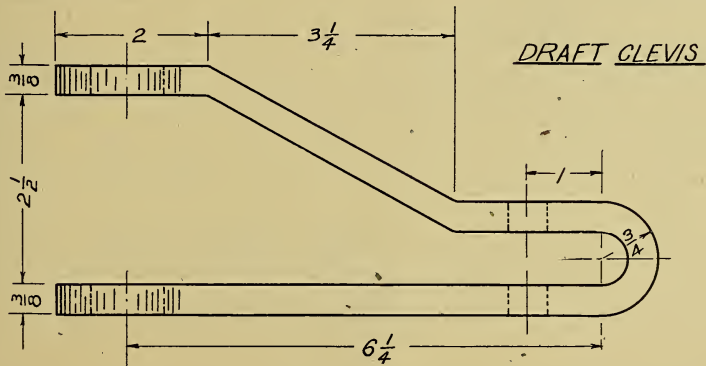
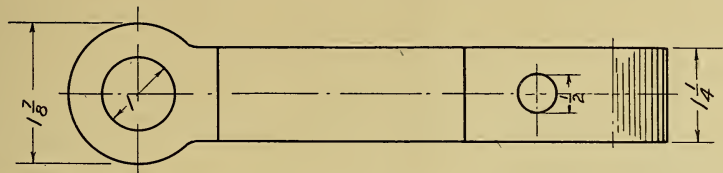

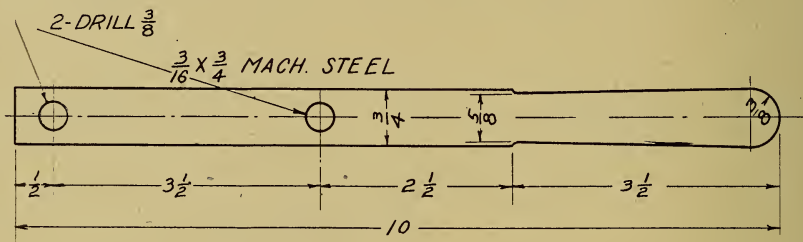

FUEL SWITCH LEVER

LUGS

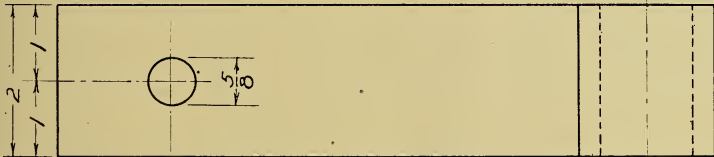
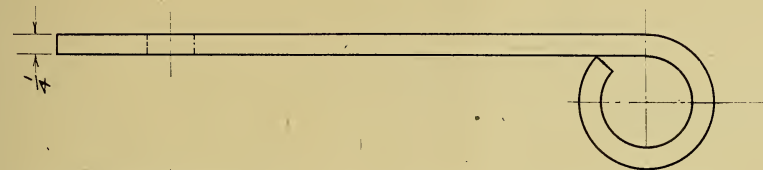

$\frac{1}{2}$ ← 3 WANTED $1\frac{3}{16}$ " LOOP 6" LONG →
← 3 WANTED 1 LOOP 8" LONG →
 $\frac{1}{4}$ X 2" COPPER BAR

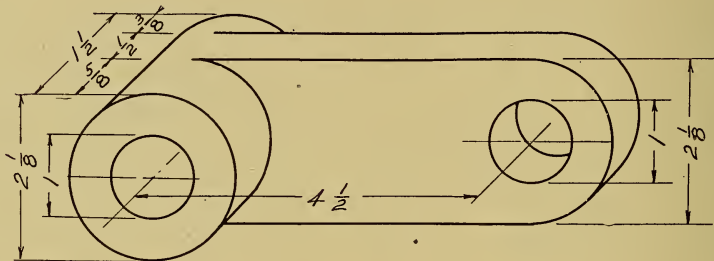

LINK

MAKE A WORKING DRAWING

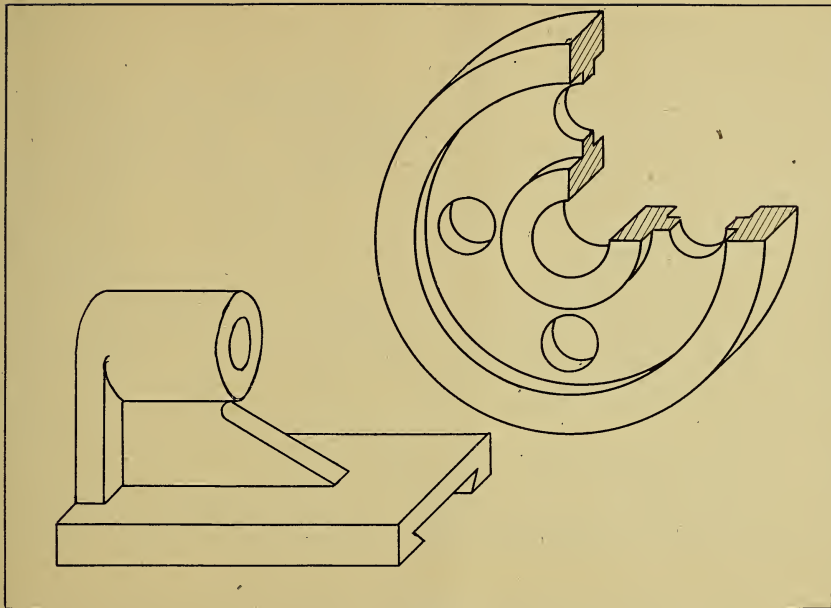

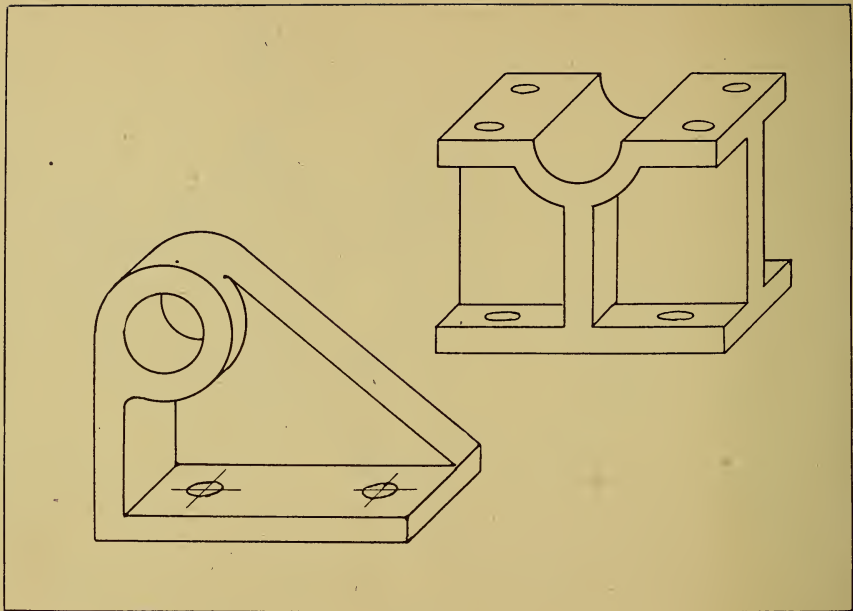

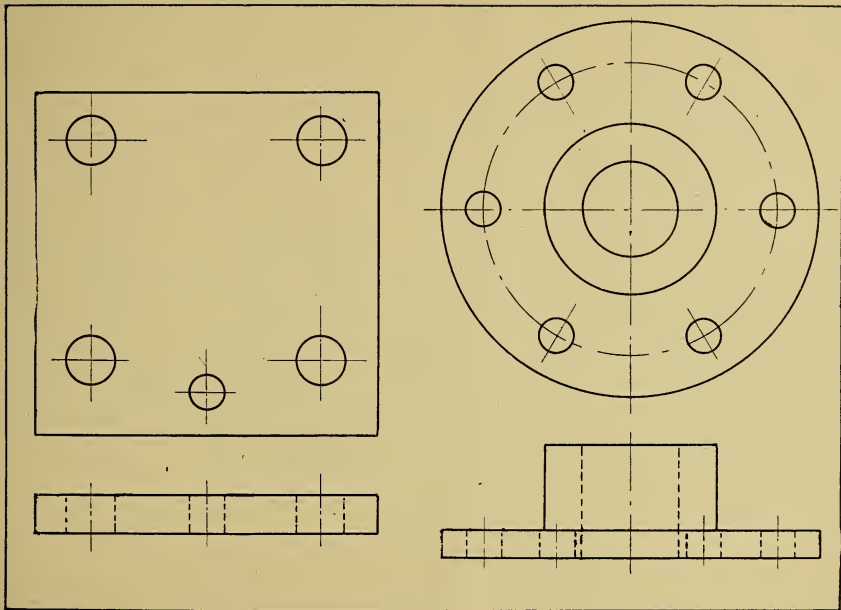

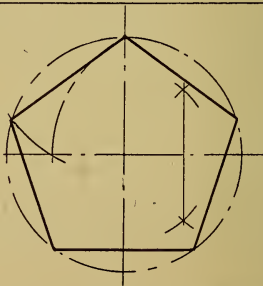
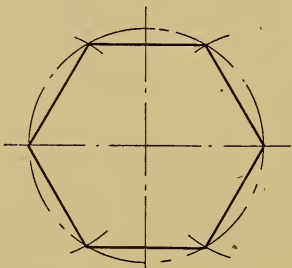
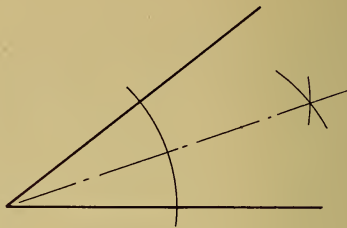
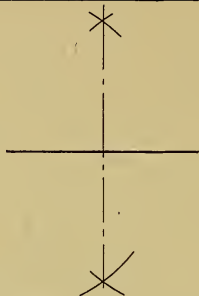

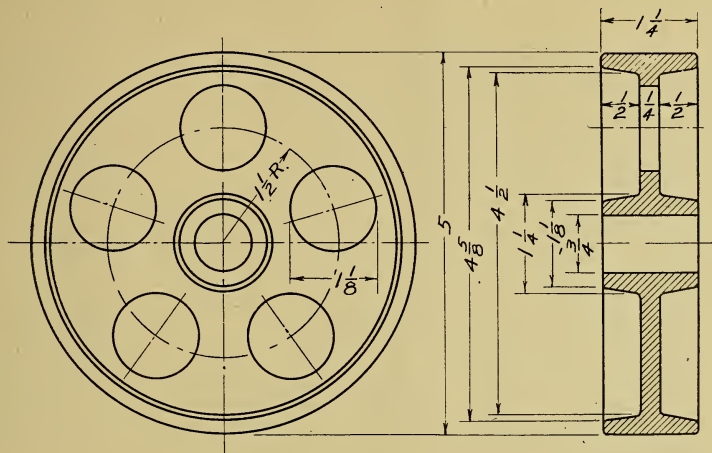

TRUCK WHEEL

CONSTRUCT A PENTAGON TO LOCATE HOLES

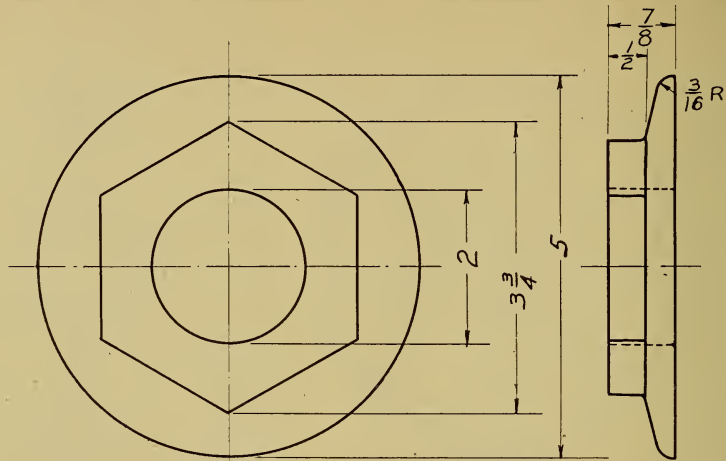

HEX. WASHER

DRAW TOP VIEW

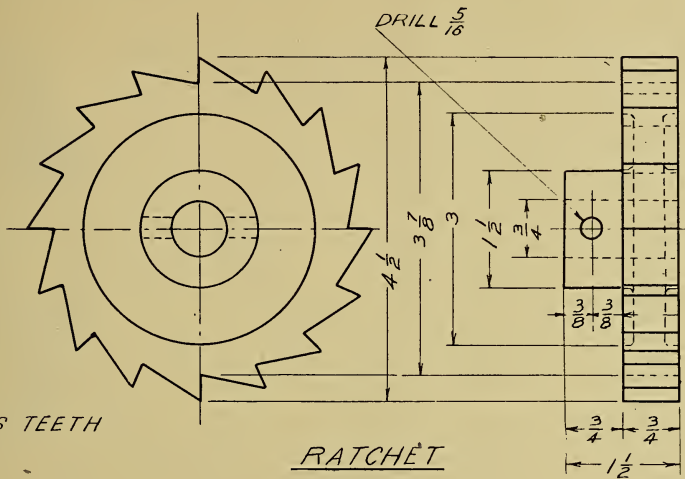

16 TEETH

RATCHET

BISECT 45° ANGLE TO GET 16 TEETH

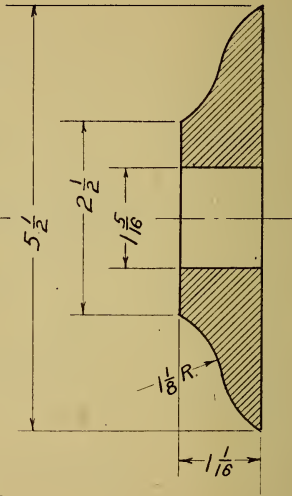
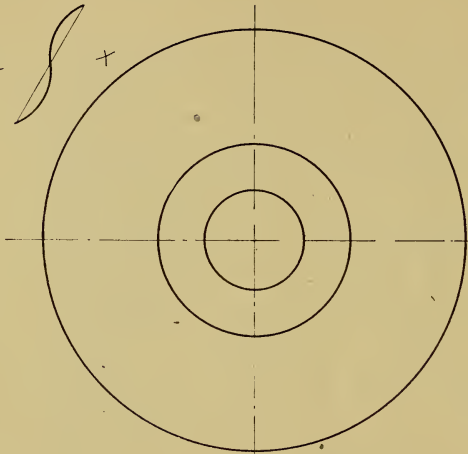

WASHER

REVERSE CURVE

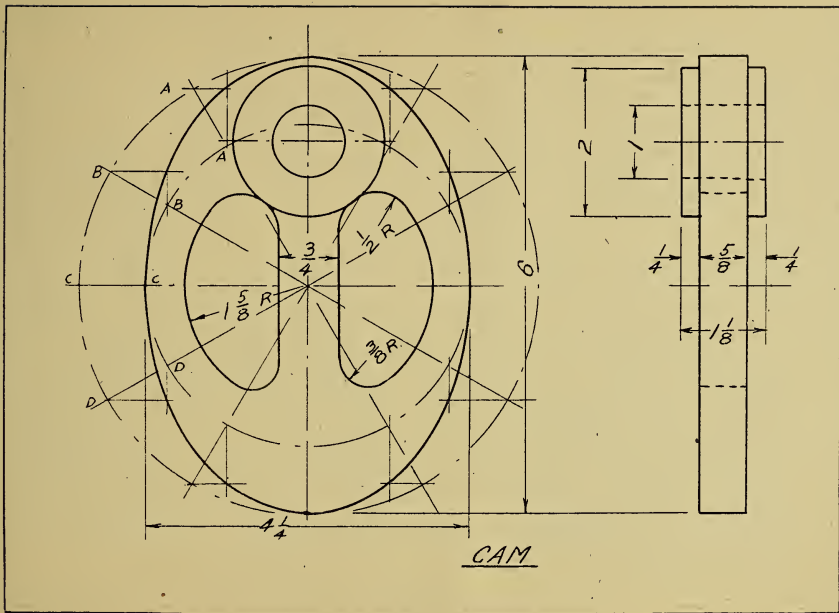

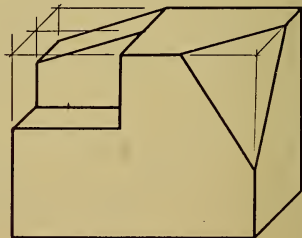
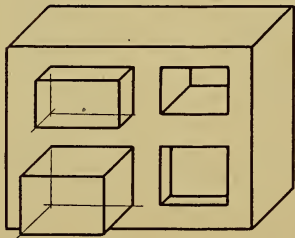
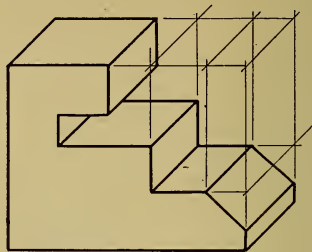
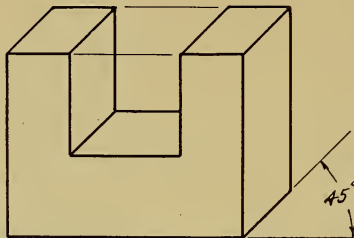

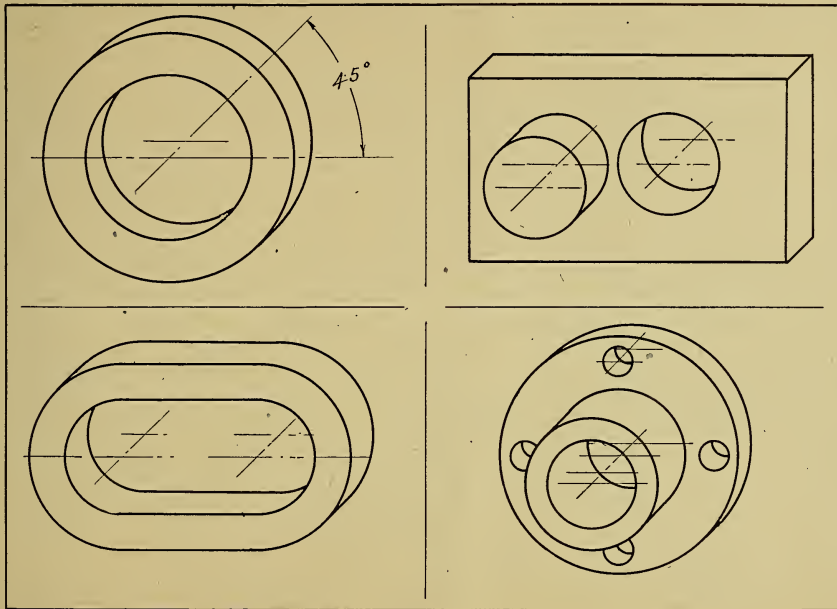

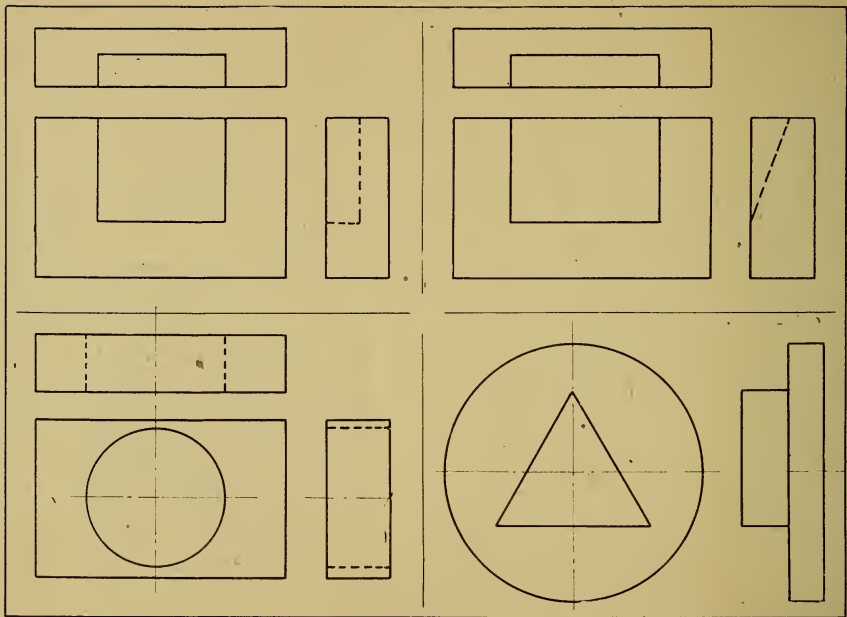

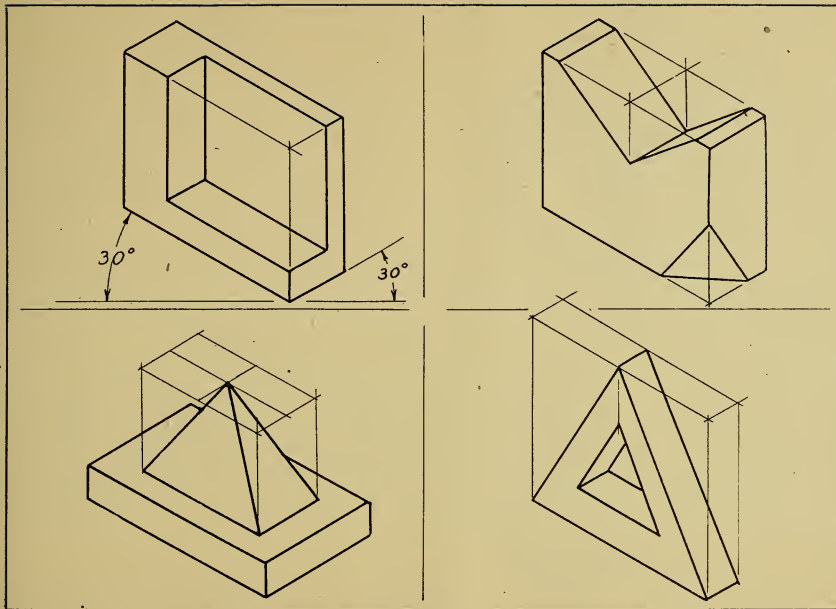

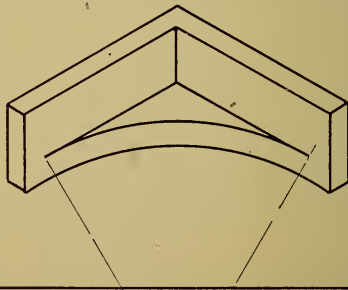
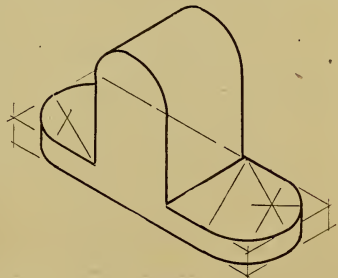
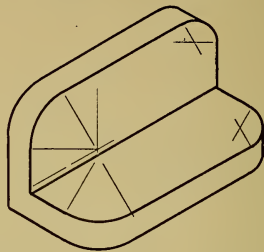
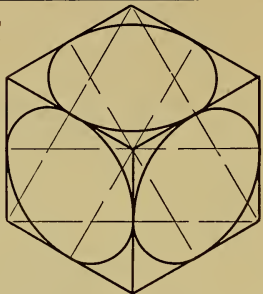

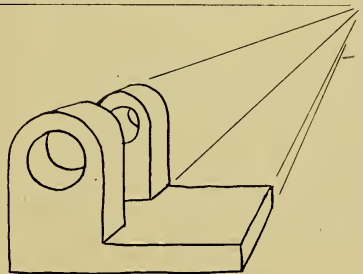
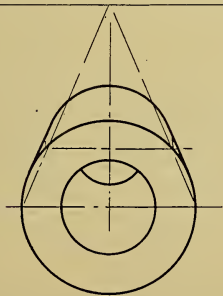
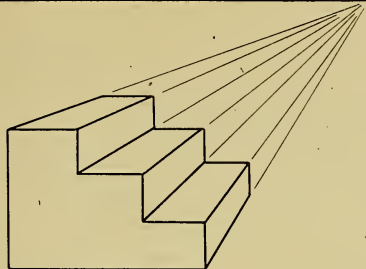
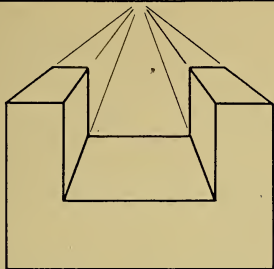

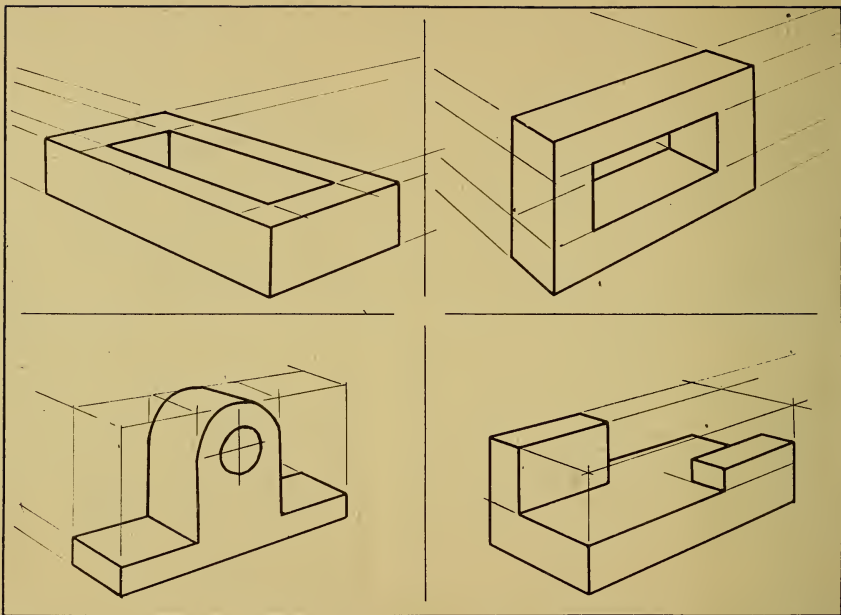

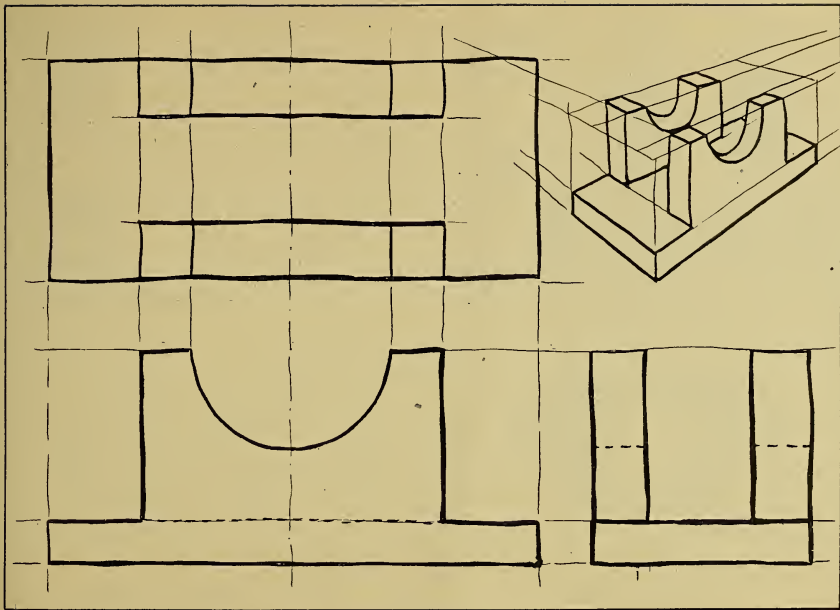

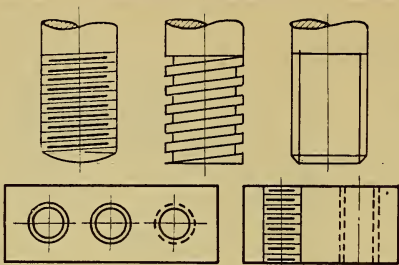

THREADS

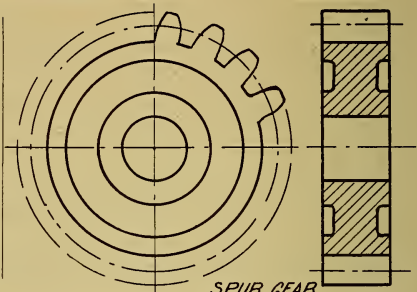

SPUR GEAR

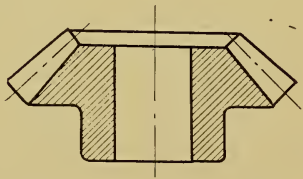

BEVEL GEAR

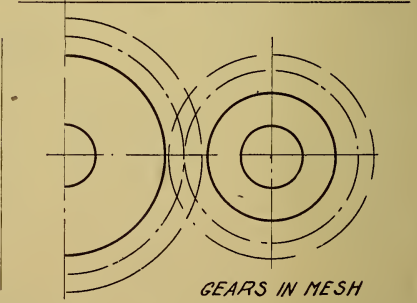

GEARS IN MESH





LIBRARY OF CONGRESS

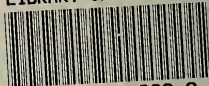

0 019 719 922 2