









327204  
23-1-1

7

THE  
GARDENER'S MAGAZINE,

AND  
REGISTER  
OF  
RURAL AND DOMESTIC IMPROVEMENT :

COMPRISING

TREATISES ON LANDSCAPE GARDENING,  
ARBORICULTURE, FLORICULTURE, HORTICULTURE,  
AGRICULTURE, RURAL ARCHITECTURE,  
GARDEN STRUCTURES,  
PLANS OF GARDENS AND COUNTRY RESIDENCES,  
SUBURBAN VILLAS, &c.

ALSO

LISTS OF NEW AND RARE PLANTS, FRUITS AND VEGETABLES.

CONDUCTED BY

J. C. LOUDON, F.L.S. H.S. &c.

AUTHOR OF THE ENCYCLOPEDIAS OF GARDENING, OF AGRICULTURE, &c.

VOL. VII.

NEW SERIES.

LONDON :

PRINTED FOR THE CONDUCTOR ;

AND SOLD BY

LONGMAN, BROWN, GREEN, AND LONGMANS,  
PATERNOSTER ROW ;

AND A. AND C. BLACK, EDINBURGH.

1841.

~~577~~

S B

403

.G 22

15  
4  
G228  
V. 7, Rev. Ser.  
1844  
SCN4213

# PREFACE.

THE various matters treated of in the *Gardener's Magazine* for 1841, will be found enumerated and classed in the following

## TABLE OF CONTENTS.

### ORIGINAL COMMUNICATIONS.

GENERAL SUBJECT.		Page	<i>Experimental.</i>		Page
<i>Historical, Statistical, and Critical.</i>					
A Summary View of the Progress of Gardening, and of Rural Improvement generally, in Britain, during the Year 1841; with some Notices relative to the State of Horticulture in Foreign Countries. By the Conductor		575	Remarks on the Application of Charcoal to the Growth of Plants		221
Gardening Visit to Paris, from June 28. to August 16. 1840:—			Theory of M. Edward Lucas's Experiments on the Effect of Charcoal on Vegetation:—		
Paris; Spirit of the People; Education of the People; Expression of Opinion; Asphalte Pavements; Butchers' Shops; Streets; Street Houses; Public Buildings; Public Gardens; Villas; Horticulture; Floriculture; Arboriculture		191	Absorption of Light, and Generation of Heat; Absorption of Atmospheric Air; Decomposition of Charcoal, and Formation of a nourishing Substance for Plants; Comparative Chemical Examination of Charcoal Dust; Antiseptic Power of Charcoal; Literature		252
London to Brighton; Dieppe; Dieppe to Rouen; Rouen the Botanic Garden, the Cemetery, the principal Improvements; Rouen to Paris; Paris, Gardens of the Palais Royal, of the Tuileries, and at Monceaux; Villa of Baron Rothschild; Bellevue, near Sévres; Belleville, at Meudon; the Château de Meudon		287	Continuation of the Experiments of the Effects of Charcoal on Vegetation, made in the Royal Botanic Garden of Munich		304
Versailles; Neuilly; St. Cloud; Sceaux; Verrières; Belleville; Elysée Bourbon, and Hotel of the English Ambassador; Nurseries and Florists' Gardens; Jardin des Plantes; Fontainebleau; Thomery; Palace of Fontainebleau; Villa of Madame de Pompadour; Havre		383	Further Results of the Experiments on the Application of Charcoal, as a Mixture with Earth, for the Cultivation of Plants in Pots		219
Notice of a Visit to Hampton Court, in Herefordshire		415	On increasing Plants by Cuttings, &c., by the Use of Charcoal		152
Notice of a Visit to Whitfield		344	On sowing Seeds in Snow		302
Notice of Bohemia Park, Sussex		593	On preserving Plants through the Winter, by Means of the Temperature of Spring Water		1
Additional Notes on the Progress of Gardening in the United States		146	<i>The Weather.</i>		
<i>Scientific.</i>			On the comparative Temperature of different Years, and its Influence on Vegetation		
The Principles of Gardening physiologically considered:—			Effects of the Winter, from December 1840 to March 1841, on perennial Plants in the open Air		147
I. On the Propagation of Plants. A. Propagation by seed, accompanied by the Phenomena of Germination		479	<i>Modes of Heating Plant Structures.</i>		
II. On the Propagation of Plants—continued. B. Propagation by Buds. I. Buds and their Metamorphoses		527	On the Application of White's Patent Stove to the Heating of Pits and other Plant Structures		3
An Experiment on Growing Plants in Earths without Organic Matter		602	Dr. Arnott's Stoves applied to the Heating of Plant-houses		431
On the Philosophy of Manures		335	On Mr. Corbett's Mode of Heating by the Circulation of Hot Water in open Gutters		151
Further Observations on the Philosophy of Manures		408	Mr. Glendinning's Opinion of Mr. Corbett's Mode of Heating by Hot Water		57
Observations on Liebig's "Organic Chemistry":—Assimilation of Carbon; On the Origin of Humus; On the Assimilation of Hydrogen; Origin and Assimilation of Nitrogen; Art of Culture; Interchanging of Crops and Manure		97	A new System of Heating Plant Structures		494
Importance of Geology, as a Study for Gardeners		433	On Mr. Penn's Mode of Warming and Ventilating		208
Importance of Natural History as a study for Gardeners		600	<i>Destruction of Insects.</i>		
Importance to Gardeners of a Knowledge of the Method of analysing Soils		489	On the Utility of washing Garden Walls to destroy Insects		555
Burning of Soils as a Means of improving them		845	On the Destruction of the Red Spider in Plant Structures		255
			On destroying the White and Brown Scale by the Application of Hot Water		255
			Snails and Slugs considered with reference to Horticulture		346
			On the Protection of Flowers in the Open Ground, &c. from Snails and Slugs		223
			The Earth-Worm, considered with reference to Horticulture		212
			On the Hornet		217
			<i>Garden Architecture.</i>		
			Dimensions and Details for erecting various Kinds of Plant Structures to be heated by Hot Water or Smoke Flues, or by both Modes combined; Cherry-house; Peach-house; Vinery; Propagating-pit for Tanner's Bark and a Flue; Propagating-pit,		

without Tan, to be heated by a Smoke Flue and Hot Water; Pit for fruiting Pine-apples; Succession-pit for Pine-apples; Winter Cucumber-pit - - - - -	308	for the Shelter and Food of Game, and as a Sea-Breeze Plant - - - - -	9
Some Remarks on the Economising of Surfaces under Glass; the Introduction of artificial Heat to Fruit Borders; and the Attainment of Bottom as well as Surface Heat from the same Heating Apparatus: - The Chinese, or Dwarf, Plantain; Granadilla; Chinese Guava; Pine-apple; Cucumber or Melon; Vine; Forcing Strawberries; Forcing Shrubs. Illustrated by Plans and Sections - - - - -	49	Arboricultural Notices - - - - -	355
A Substitute for Hand-glasses, and a more economical Mode of using Glass in Forcing-houses suggested - - - - -	204	Measurement, Age, &c., of Trees at Blair Drummond, Scotland - - - - -	505
On different Modes of Glazing Plant Structures - - - - -	606	On the Incombustibility of the Larch - - - - -	226
Further Information respecting the flued Walls at Erskine House - - - - -	256	On the <i>Cytisus Adami</i> , or Purple Laburnum - - - - -	58
Some Account of a Pit for preserving Ice, in Use at Erskine House, Renfrewshire - - - - -	434	On the Propagation of the <i>Rhododendron dauricum</i> , and other Species of the same natural Family, by Cuttings - - - - -	462
Description of a Mode of arranging Hempen Lines for supporting Scarlet Runners, Convolvuluses, or other twining Plants - - - - -	211	Notice of a simple Mode of taking the Height of Trees - - - - -	350
<i>Implements.</i>			
Notice of a Draw-hoe in Use in Leicestershire - - - - -	311	<b>FLORICULTURE.</b>	
Notice of Three new Garden Tools - - - - -	257	Botanical, Floricultural, and Arboricultural Notices of the Kinds of Plants newly introduced into British Gardens and Plantations, or which have been originated in them 10. 61. 167. 258. 324. 356. 556	
Notice of a Ladder for thinning Grapes in Hothouses - - - - -	210	The Flower Garden at Esholt Hall; its Design, Culture, and Management - - - - -	610
<b>LANDSCAPE-GARDENING.</b>			
On Gardening as an Art of Design and Taste The Landscape-Gardening of F.L. von Skell of Munich: - - - - -	157	List of Plants adapted for a Conservatory Wall, with Remarks on some of the Species - - - - -	239
I. General Observations on the Modern Natural Style of Gardening, with some Remarks on the Ancient Symmetrical Style - - - - -	353	Observations and Reflections on the Cultivation of the <i>Cacti</i> - - - - -	510
II. Selection of Natural Scenes suitable for the Adaptation of the Landscape-Gardener - - - - -	411	On the Management of <i>Cacti</i> - - - - -	169
III. On the Architectural Edifices which are suitable for a Garden. IV. The Situation Temples in Pleasure-Grounds. V. On the different Kinds of Trees, Shrubs, and Flowers, which were particularly dedicated to the different Gods and Goddesses, and which should surround their respective Temples, as Part of their Attributes - - - - -	497	On bringing the <i>Cacti</i> raised from Seed quicker into Flower - - - - -	357
V. On the different Kinds of Trees, Shrubs, and Flowers, which were particularly dedicated to the different Gods and Goddesses, and which should surround their respective Temples, as part of their Attributes. - <i>continued.</i> VI. Architectural Decorations. VII. Bridges in Gardens. VIII. The first Proceedings on the Spot which is to form the Natural Garden. IX. On Staking out and Tracing on the Ground the Forms and Outlines of the Natural Garden, with reference to Character, Effect, and Beauty - - - - -	536. 603	Catalogue of the <i>Cacti</i> in the Collection of the Rev. Theodore Williams, at Hendon Vicarage, Middlesex - - - - -	313
Design for laying out a Suburban Residence - - - - -	350	On the Culture of the splendid Lake Rose, <i>Nelumbium speciosum Willd.</i> - - - - -	513
A new Method of forming Living Arbours - - - - -	312	On the Culture of <i>Ixias</i> and other <i>Irideæ</i> in the Island of Jersey - - - - -	15
<b>ARBORICULTURE.</b>			
Report on the New Trees and Shrubs raised in the Horticultural Society's Garden in the Year 1841 - - - - -	608	On the Culture of the <i>Gladolus cardinâlis</i> - - - - -	461
On the Culture of Timber Trees - - - - -	508	On the Propagation of Dahlias - - - - -	416
On Mr. Gavin Cree's System of Pruning Forest Trees, containing an Outline of his Method - - - - -	435	Observations of the Propagation of the <i>Dahlia</i> - - - - -	516
On Pruning Forest Trees - - - - -	440	Notice of a <i>Petunia</i> of extraordinary Dimensions - - - - -	9
On Pruning Forest Trees - - - - -	444	<b>HORTICULTURE.</b>	
On Pruning Trees in General - - - - -	555	Report on the New Fruits and Culinary Vegetables raised in the Horticultural Society's Garden since the last Report in 1837 - - - - -	614
Copy of a Letter addressed to Sir Charles Gordon, Secretary to the Highland and Agricultural Society of Scotland, on Pruning Trees - - - - -	458	A Systematic Plan for a Gardener to "serve the Kitchen" - - - - -	7
On the Thinning of Forest Trees - - - - -	550	On Root-Pruning of Fruit Trees - - - - -	615
Remarks on several Species of <i>Conifera</i> , with Reference to the Climate of North Britain - - - - -	164	On the Use of inclined Walls for growing the finer Sorts of Fruits - - - - -	360
On <i>Leycesteria formôsa</i> , as an Undergrowth		On the Cultivation of the Pine-apple, as practised in the Kitchen-garden of the Palace of Versailles in the Year 1840 - - - - -	17
		On the Use of the Species of <i>Pisang</i> ( <i>Musa paradisiaca</i> ) and the <i>Banana</i> ( <i>Musa sapientum</i> ) - - - - -	490
		On the Effects of Water on the Growth and Ripening of Melons - - - - -	465
		On the Culture of the Cucumber in Pits heated by Hot Water - - - - -	262
		On the Destruction of Mice in Cucumber Frames - - - - -	26
		On the Cultivation of the Grape Vine - - - - -	21
		On growing Three Crops of Grapes in One House - - - - -	73
		On the Shriveling of Grapes - - - - -	170
		On the Shriveling of Grapes - - - - -	171
		On the Shanking and Shriveling of Grapes - - - - -	173
		On the Shanking of Grapes - - - - -	262
		On the Cultivation of the Peach in Pots, in Pine-houses - - - - -	321
		On the Culture of the Peach in the open Air - - - - -	63
		Mode of destroying the Green Fly on Peach Trees - - - - -	73
		An Account of some remarkable old Pear Trees at Dunmarle, Culross, Perthshire - - - - -	464
		On growing Strawberries for Forcing - - - - -	564
		Description of a Mode in which Mushrooms may be grown under the Paths of a Hot-house - - - - -	207
		Observations on the Culture of the Gooseberry and Raspberry - - - - -	465
		On the Hautbois Strawberry - - - - -	266
		On the Culture of the Conical-fruited Scarlet Alpine Strawberry - - - - -	266
		A Method of sowing Peas and Beans in Boxes for Transplanting - - - - -	74
		On the Culture and Forcing of Rhubarb - - - - -	174

On Forcing Sea-kale - - - - -	269
An accidental Discovery of an improved Mode of Blanching Sea-kale and Rhubarb with Peat Soil - - - - -	75
Comparative Results from cultivating Nine Sorts of Celery - - - - -	76
On the Culture of the Early Horn Carrot - - - - -	27

BEE CULTURE.

Remarks on placing the Entrance to Bee-hives - - - - -	77
--	----

DOMESTIC ECONOMY.

On the Manufacture of Rose-water and Attar, or Otto, of Roses, at Ghazeepore - - - - -	359
--	-----

AGRICULTURE.

Notice on <i>Festuca ovina L.</i> , <i>Festuca rubra L.</i> , and <i>Bromus pratensis L.</i> , as Pasture and Lawn Plants - - - - -	467
---	-----

REVIEWS.

GENERAL SUBJECT.

The Field, the Garden, and the Woodland. By a Lady - - - - -	326
Pratt's Flowers and their Associations - - - - -	228
Transactions of the Pennsylvania Horticultural Society - - - - -	176

Scientific.

A Selection from the Physiological and Horticultural Papers published in the <i>Transactions of the Royal and Horticultural Societies</i> by the late Thomas Andrew Knight, Esq. - - - - -	327
Vegetable Physiology - - - - -	327. 616
Rhind's History of the Vegetable Kingdom, 228. - - - - -	624
The Phytologist, a Botanical Journal - - - - -	624

Catalogues, &c.

Loudon's First Additional Supplement to the <i>Encyclopædia of Plants</i> - - - - -	369
Link, Klotzsch, and Otto's <i>Icones Plantarum Rariorum</i> - - - - -	84. 369
Fowld's, Young's, and Gregory's Nursery Catalogues - - - - -	33
Lucombe, Pince, and Co.'s Sale Catalogue of Plants belonging to the Natural Order <i>Conifera</i> - - - - -	86
Carter's Catalogue of Seeds for 1841 - - - - -	177
Graham's Catalogue of the Plants growing in Bombay and its Vicinity - - - - -	85
Riley's Catalogue of Ferns - - - - -	176
A Catalogue of Plants collected in the Neighbourhood of Banbury. By George Gulliver, F.R.S., F.L.S. - - - - -	625
A Manual of the British Algæ; containing Generic and Specific Descriptions of all the known British Species of Sea-weeds, and of <i>Confervæ</i> , both Marine and Freshwater. By the Honourable William Henry Harvey - - - - -	625

Botanical Notices.

DeCandolle's Description d'une Nouvelle Espèce de Figulier - - - - -	85
DeCandolle's Huitième Notice sur les Plantes Rares cultivées dans le Jardin de Genève - - - - -	85
Germain's Observations sur quelques Plantes Critiques des Environs de Paris - - - - -	177
Webb's Notice sur le <i>Paulownia</i> - - - - -	177
A Series of Botanical Labels for the Herbarium - - - - -	229

LANDSCAPE-GARDENING.

A Treatise on the Theory and Practice of Landscape-Gardening, adapted to North America; with a View to the Improvement of Country Residences. With Remarks on Rural Architecture. By A. J. Downing - - - - -	421. 472
--	----------

ARBORICULTURE.

Die Coniferen nach Lambert, Loudon, und anderin. Frey bearbeitet von Franz Antoine. The Coniferæ after Lambert, Loudon, and others. Newly composed by F. Antoine - - - - -	28. 624
--	---------

A History of British Forest Trees. By Pri-deaux John Selby, F.R.S.E., F.L.S., &c. - - - - -	624
The Eastern Arboretum, or Rural Register of all the remarkable Trees, Seats, Gardens, &c., in the County of Norfolk. By James Grigor - - - - -	29. 270. 624

FLORICULTURE.

A Descriptive Catalogue of Roses. By H. Lane and Son - - - - -	624
--	-----

HORTICULTURE.

The Kitchen-Garden; extracted by permission from the British Almanack of the Society for the Diffusion of Useful Knowledge for the Year 1837 - - - - -	625
Manning's Book of Fruits - - - - -	176
Catalogue Raisonné des Arbres Fruitières, &c. - - - - -	620
Rivers's Hints on Root-Pruning, &c. - - - - -	625
Mills's Treatise on an improved Mode of cultivating the Cucumber and Melon - - - - -	229
Ayres's Treatise on the Cultivation of the Cucumber in Pots, &c. - - - - -	327
Cucumber Culture. By John Duncan - - - - -	274

AGRICULTURE.

The Journal of the Royal Agricultural Society of England - - - - -	79. 625
The British Farmer's Magazine for 1841 - - - - -	626
Three Lectures on Agriculture. By Dr. Daubeny, F.R.S., M.R.S.A., &c. - - - - -	270
The Farmer's Encyclopædia, and Dictionary of Rural Affairs. Illustrated by Wood Engravings of the best and most improved Agricultural Implements, &c. Forming one of the Series of Encyclopædias and Dictionaries now in course of Publication. By Cuthbert W. Johnson, Esq. - - - - -	625

RURAL ARCHITECTURE.

Graphic Illustrations, with Historical and Descriptive Accounts, of Taddington, Gloucestershire, the Seat of Lord Sudely. By John Britton, F.S.A. - - - - -	362. 418
Ricauti's Rustic Architecture - - - - -	34
Illustrations and Descriptions of Kilpeck Church, Herefordshire; with an Essay on Ecclesiastical Designs. By G. R. Lewis - - - - -	627
Austin and Seeley's Specimen Book of their Artificial Stone Manufactory, New Road London - - - - -	370
Model Mapping, as suggestive of a general and Economic System of Drainage and Irrigation, &c. By J. Bailey Denton - - - - -	626
Description and Use of an improved Leveling Staff. By T. Sopwith, F.G.S. - - - - -	627
Report of the Select Committee appointed to inquire into the present State of the "National Monuments and Works of Art, &c." - - - - -	627

THE WEATHER.

Leigh's Hints for an Essay on Anemology and Ombrology - - - - -	87
White's Theories of the Weather Prophets, and the comparative Success of their Predictions - - - - -	370

The British Almanack, and the Companion to the Almanack for 1841	- 34
The Farmer's Almanacks and Calendar for 1842	- 628

## MISCELLANEOUS.

The Seventh Annual Report of the Royal Cornwall Polytechnic Society	- 177
The Eighth Annual Report of the Royal Cornwall Polytechnic Society	- 626
Brande's Dictionary of Science, Literature, and Art	- 177, 626
Transactions of the Society for the Encouragement of Arts, Manufactures, and Commerce	- 275
Lectures on Chemistry, including its Application in the Arts. By Henry M. Noad	- 626

## MISCELLANEOUS INTELLIGENCE.

## GENERAL NOTICES.

*Historical and Statistical.*—The Gardeners' Book Society of Croydon, 35; What constitutes a Gardener, 629; Order Book, 629.

*Scientific.*—The Theory of Excretions of Plants, 629; Effect of coloured Light, 629; Charcoal Dust, 630; Sawdust mixed with Stable Manure, 630; Pounded Brickbats, 630; The Guernsey Weeding Prong, 630; Germination of Seeds, 519; Average Temperature at which Seeds will germinate, 375; Respiration of Plants; 181; Sending Home Seeds from warm Climates, 562; Sending Home Seeds from foreign Countries, 630; The Oxygenation of Water, 631; Suspended Vegetation, 631; Raising Plants from Seed, 632; Root-pruning, 632; Acclimatising Plants, 632; Neatness often the Cause of impoverishing the Soil, 632; The Scion will affect the Quality, although not the Organization of the Stock, 632; Propagation by Leaves, 633; Budding, 633; Sending Cuttings by Letter, 88; Objections to turning in Snow when digging or ploughing, 377; Garden Culture of Exotics, 87; Sawdust as Manure, 376; Striking from Leaves, 376; Root-grafting, 377; Roadmaking, 282; Paving Roads with India-rubber, 638; Experiments for the Destruction of Moss on Gravel Walks, 281; Growth of Fig Branches without Roots, 375.

*Insects.*—Insects on Plants, 427; To destroy Caterpillars, 475; The Gooseberry Caterpillar, 521; Caterpillars on Vines, 328; The Maggot in Onions, 83; American Blight, 229; Recipes for destroying Ants, 280; Wire-Worms, 475; Trap for Woodlice, 281; Woodlice among Orchidææ, 378; Earthworms, 329; Tobacco Paper, 634; Tobacco Water, 634; Spirit of Tar, 634; Sulphurated Hydrogen Gas, 634; Stifing Insects, 634; Detering Insects by Mud, 634.

*Diseases.*—Canker in Fruit Trees, 377.

*Landscape-Gardening.*—To destroy Moss in Lawns, 634.

*Garden Structures, Implements, &c.*—Heat considered relatively to Plant Structures, 634; Boiler Furnaces, 635; The Construction of Pipes for circulating hot Water, 634; Laying Hot-water Pipes in Troughs of Water, 635; Glazing Hot-houses, 635; Old Putty softened, 635; A Pit for wintering Plants, 635; Fruit-Room, 635; Construction of a Fruit-Room, 636; Ventilation of Plant Structures, 637; Tanner's Bark Walks, 637; A Forcing-House which may be applied to various Purposes, 563; Green's Cucumber Pit, 281; Smoke Flues, closed Hot-water Pipes, and Water in open Gutters, as Modes of Heating, 377; An Ice-house under Rockwork, 563; Tared Canvas for Coverings, 280; Oil-Paper Frames, 562; Pockock's Asphalte Roofing, 280; Receipts for preparing artificial Asphalte, 564; Indian-Rubber Pavement, 87; Pince and Co's permanent Botanical and Horticultural Tally, 230; Garden Syringes, 35; The Wickerwork

The Entomologist. Conducted by Edward Newman, F.L.S., Z.S., &c.	- 626
The Journey-Book of England	- 628
A Development of the Principles and Plan on which to establish Self-supporting Home Colonies; as a most secure and profitable Investment for Capital, and an effectual Means permanently to remove the Causes of Ignorance, Poverty, and Crime; and most materially to benefit all Classes of Society, by giving a right Application to the now greatly misdirected Powers of the Human Faculties and of Physical and Moral Science. By Robert Owen	- 628

## LITERARY NOTICES.

The Guide to the Conservatory. By Richard Bainbridge	- 286
--	-------

Dahlia Protector, 377; The Potting-bench Instrument, 563; New Besom for Garden Purposes, 230; A Camera Lucida, well adapted for Gardeners, 278; Ropes from metallic Wire, 87.

*Arboriculture.*—Botanic Garden Reports of new Trees and Shrubs, 35; Economical Planting, 564; Vitality of the Genera *Pyrus* and *Crataegus*, 278; Propagating Coniferous Plants by Cuttings, 638; Stunted Ash Trees, 638; Rabbits and Gamekeepers, 639; Autumn Planting, 639; Certain Species of European Pines, 639; Shrubs, 641; Pruning and Lopping, 641; *Cedrus Deodara*, 641; *Araucaria imbricata*, 641; *Quercus fastigiata* and *Q. alba*, 641; The Terms red and white Oak, 641; The sweet Bay, 641; The Savine, 641; *Rhus Côtinus*, 641; Birches and other Coppices, 641; Tree Guards, 641; Autumnal Colouring of *Quercus* and *Rhus*, 36; American Oaks, 36; Preservation and Staining of Wood, 178; Kyanised Timber, 279; Preparation of Timber, 374; Boucherie's Mode of preserving Timber; 642; Boucherie's Mode of increasing the Elasticity of Wood, 643; Burnett's Mode of Preserving Timber, 643.

*Floriculture.*—Fastening down Plants, 643; Growing Annuals in Pots, 643; Budding Roses, 643; Pruning Roses, 644; Propagation of Pinks, 644; Culture of the *Amaryllis*, 644; *Crinum capense*, 645; *Roscoeia purpurea*, 645; The Marchioness of Exeter's Camellia, 645; *Sálvia patens*, 645; *Abutilon striatum*, 645; *Abutilon vitifolium*, 645; *Fuchsia discolor*, 645; *Physianthus albicans*, 645; *Oxalis Acetosella*, 645.

*Horticulture.*—Canker in Fruit Trees, 645; Vines, 645; Preservation of Grapes, 646; Mr. Hayward's Manure for Grapes, 646; Keeping Fruit, 646; Raspberries, 646; Thinning Pears, 646; The Scale on Peach Trees, 646; Preserving Pears on the Trees, 646; Wild Crab, 646; Pears, 646; Keeping Apples and Pears 647; Package of Fruit, 647; Roots of Fruit Trees, 647; The Spanish Filbert, 647; Gooseberries, 647; Gooseberry Cuttings, 647; The Club in the Cabbage Tribe, 647; Asparagus, 648; *Oxalis Dépéei*, 648; Comfrey, 648; Victoria Rhubarb, 648; Myatt's Pine Strawberry, 648; *Fuchsia fulgens*, 648; Cucumber and Melon Culture, 35; Steaming Mushroom-houses, 328; Covering Strawberry-beds with Netting, 229; Preserving Currants on the Bushes till Christmas, 564; Artificial Maturation of Figs, 37; The Quince, 564.

*Domestic Economy.*—On boiling Potatoes, 329; Curdling of Milk, 521; Aspergillus glaucus, or Cheese Mould, 329.

*Agriculture.*—*Trifolium incarnatum*, 648; Agriculture, 281; Lime in Agriculture, 476; Ravages of Worms at the Roots of Corn, 522; *Bromus pratensis* and *Festuca Urrii*, 564.

*The Weather.*—On a Method of prognosticating the probable Mean Temperature of the several Winter Months from that of corresponding

Months in the preceding Summer, 180; Hoarfrost, 374.

*Education.*—Amount of Instruction worthy of the Title of Education, 88; Music, as a Branch of Popular Education, 88; Necessity of Amusement, 89.

*Miscellaneous.*—The Use of Sulphate of Lime, 521; Disinfecting Night-Soil and Stable-Dung, 374; Nets dyed Blue, 378; The Landscape-Painter, 373; The Solar Ray, 562; Derangement of the Spinal Column, 330.

## FOREIGN NOTICES.

## FRANCE.

New Herbaceous Peonies, 378.

## GERMANY.

Culture of *Hepatica triloba*, 522; Notes of a Botanical Tour, Edward Otto, 379; Extracts from the Epistolary Correspondence of Edward Otto, during his Voyage to Cuba, and his Abode there, 523, 549; Storm at Louisaine, near Desau, 648.

## ITALY.

Gardening in Lombardy, Roses, Method of multiplying Camellias, Giuseppe Manetti, 565; *Salisbùria adiantifolia*, and other Matters, G. Manetti, 182.

## RUSSIA.

Climate and Culture of Cucumbers in Courland, 90; Winter of 1840-41, 525.

## ASIA MINOR.

Chips of Firewood for giving Light, 378.

## AFRICA.

On the Malaria of the Western Coast of Africa, 567.

## INDIA.

Education in Travancore, 379; The Roses of Ghazepore, 379.

## NORTH AMERICA.

Philadelphia Improvements, 428; American exploring Squadron, 3569; *Jussiaea grandiflora*, 91; Sweet and Sour Apple, 476; Maple Sugar, 379; New Cherry Tree from the far West, 330; To secure good Fruit, 476; Mammoth Cabbage, 330; Supposed new Cherry, 569; Sourmiler Potato, 331; Live Oak, 476; *Ailantus glandulosa*, 569; *Macilura aurantiaca*, 569; New Edition of Michaux's *Sylva*, John Torrey, 569.

## SOUTH AMERICA.

Rio Janeiro, Dr. J. F. Lippold, 27.

## DOMESTIC NOTICES.

## ENGLAND.

Public Park in the East of London, 331; Kensington Gardens, 331; Parks and Pleasure-Grounds, 282; Presentation, by the Bath Royal Horticultural and Botanical Society, of a Cup to Mr. Baxter, 283; New or rare Plants lately raised in the Botanic Garden, Liverpool, Henry Shepherd, 38; The Exhibition at the Horticultural Society's Gardens, 331; Chureyards at Lancaster, D. Saul, 230; Margins of the great Lines of Railway, 332; The Bokhara Clover, R. Forest, 231; The Effect of Under-draining, 477; *Pinus Lambertiana*, 429; The Greenhouses in the Wakefield Nursery, 570; The Great American Aloe, 525; *Brugmansia bicolor*, W. H. B., 477; *Cereus Northumberlandia* and *Cyperus longus*, A. B. Lambert, 91; *Culex tuberosus*, 92; Bad Effect of growing Peaches and Grapes in the same House, J. Nash, 571; Weight of Queen Pines cut at Presswold in 1840, W. Brown, 231; Immense Mushroom, 526; The Gigantic Flax, 184; Cotton Plant, 38; Jelly from the Berries of *Ribes sanguineum*, 231; Geese destroyed by eating Monk's-hood, 651; Instinct of Pigeons, 652; Habit of the Virginian Nightingale, 652; Effects of the Winter of 1837-8, W. Godsall, 571.

## SCOTLAND.

Glasgow Botanic Garden, 231; General Cemetery near Edinburgh, 332; The "King's Knot" at Stirling, 652; The Douglas Monument, 477; Sir John Robison's Plant Case, 333; White's Patent Heating Apparatus, 332; Improvements in Cottage Buildings and Cottage Gardens, 572; Timber Bridges, 38; Names of African Plants, 231; *Rhododendron anthonpogon*, 652; Agricultural Museum at Glasgow, 652.

## IRELAND.

Bequest of Books to the Botanic Garden, Glasnevin, 284; *Pinus pumilio*, 184.

## RETROSPECTIVE CRITICISM.

The Derby Arboretum, 381; Chatsworth, Alton Towers, and Trentham, 40; The Conservative Wall at Chatsworth, 45; The Glazing of the Chatsworth Conservatory, 45; Chatsworth Conservatory, 92; The Pleasure Grounds at Theobalds, 92; The Monument to the Memory of Mr. Douglas, 184; Burning of Soils, as a Means of Improving them, 478; Transmission of Cuttings by Post, 237; Rooting Cuttings in Charcoal, and rooting Seeds in Snow, 653; Semicylindrical Draining-Tiles, 44; Architectural Objects in Gardens, 235; Mr. Niven's Stove for various Purposes, 234, 334, 429, 478; Mr. Forsyth's Plant Structures, 285; Mr. Penn's Mode of heating Hothouses, 42; Mr. Penn's Mode of Heating, as contrasted with other Modes, 43; Mr. Penn's Practice in Heating, &c., 231; Mr. Penn's Mode of heating and ventilating Hothouses, 232; Mr. Penn's Mode of Heating and Ventilating, 285; Mr. Penn's Mode of Heating, 185; Mr. Penn's Mode of Heating at Chatsworth, 234, 333; Mr. Rogers's Conical Boiler, 43; On the Natural Succession of Forest Trees in the United States, 93; American Button Wood, or Plane Tree, 93; *Quercus virens*, *Phellos*, and *pubescens*, and *Ulmus effusa*, 93; Calling of the Queen Bee, 94; Plants adapted for a Conservative Wall, 334, 382; Propagation of the Dahlia, 573; *Daphne Cneorum*, and *D. Dauphina*, 654; The Orange Groves of East Florida, 93; Rust on Vines, 46; Shriveling and Shrinking of Grapes, 45; Shriveling of Grapes, 235, 334; Mr. Mackenzie's Mode of cultivating the Gooseberry and Currant, 573; Recent Urine of Sheep, 572; Comparative Temperature of different Years, 235, 284.

## QUERIES AND ANSWERS.

Mr. Parkyns, the Author of "Monastic Remains, &c., 654; To protect Forest Trees from the Ravages of Hares and Rabbits, 96; Preventing Hares and Rabbits from injuring the Bark of Trees, 237, 286; To prevent the Ravages of Hares and Rabbits on Forest Trees, 237; Propagating the Mistletoe, 47; White Seale, Brown Seale, Woodlice, Singing-Birds, 185; The small Stag-Beetle, 186; The Onion Maggot, 185; Preventive against the Depredations of Snails on Wall-Fruit, 574; Felling Resinous Trees, 237; The best Plan for managing an old Orchard, 574; *Musa Cavendishii*, 334; *Musa Cavendishii* as a substitute for Pines, 430; Painting Vines with Clay, 237; The Curl in the Leaves of Vines, 96; Curling of Vine Leaves, 48; The Curl in Vine Leaves, 48; Shanking of Grapes, 47; Shanking and premature Shriveling of Grapes, 47; Oak Spangles, 186.

*The West London Gardeners' Association for mutual Instruction*:—Forcing and general Cultivation of the Strawberry - - 39

## BIOGRAPHY.

Mr. William Beattie, F.H.S., 237; Daniel Ellis, Esq., F.R.S.E., &c., 188; Francis Bauer, Esq., 186; John Cowham Parker, Esq., W.S., 190.

## OBITUARY.

M. Augustus Pyramus DeCandolle, 654; Prince Butera, 654; Lord Monson, 593.

## LIST OF ENGRAVINGS.

No.	DIAGRAMS.	Page	INSTRUMENTS, IMPLEMENTS, UTEN- SILS, AND MACHINES.	No.	Page
20, 21.	Illustrative of a Method of training the Peach Tree -	68, 69	28-30.	Views and Section of a Ladder for thinning Grapes in Hothouses -	210
23.	Section of a Projecting Kerb Stone -	195	34.	Cap for covering the Holes in the Bottoms of Pots -	217
24.	Elevation of the Obelisk of Luxor -	198	35.	A Galvanic Plant Protector -	224
31, 32.	View and Section illustrative of a Method of supporting Climbing Plants -	211	36.	Galvanic Protector for Fruit Trees on Walls -	224
37.	Illustrative of a Method of making a Galvanic Plant Protector -	226	38, 39.	Tallies for Trees and Shrubs -	230
51.	Part of a Disbarked Lime Tree -	401	40.	A Drill Rake -	257
<b>GARDEN STRUCTURES.</b>			41.	A Drill Hoe -	258
1-3.	Plan, Section, and Isometrical View of a Frame for Preserving Plants through the Winter -	2, 3	42.	A Sickle Hoe -	258
4-12.	Plans, Sections, and Elevations of Houses and Pits, showing White's Mode of Heating them -	3-7	43.	Double Dutch Hoe -	258
13-17.	Plan, Sections, and Elevation of a Forcing-House -	50-54	58.	The Guernsey Weeding Prong -	630
18, 19.	Plan and Section of a Pit to be heated by Corbett's System -	57, 58	44.	Camera lucida for Gardeners -	279
25-27.	Perspective View, Plan, and Elevation of a Hand-Box, as a substitute for Hand-Glasses -	207	47, 48.	Section and Views of a New Draw Hoe -	311
45, 46.	Chairs adapted for Public Gardens -	288, 298	49.	Measuring Staff -	350
52.	Section of a Hotbed on Forsyth's System -	494	<b>PLANS OF GARDENS AND COUNTRY RESIDENCES.</b>		
			50.	Design for a Suburban Residence -	351
			53-57.	Esholt Hall -	612, 613
			<b>INSECTS.</b>		
			22.	<i>Dórcus parallelipèdus</i> -	186
			33.	Eggs of the Earth Worm -	215

## LIST OF NEW AND RARE PLANTS

FIGURED IN THE BOTANICAL PERIODICALS FOR THE YEAR 1841.

<i>Ranunculàcæa.</i>			<i>Besamínæa.</i>		
ANEMONE	montàna	✓ Switzerland - - - 557	INPATIENS	cándida	○ Himalayas - - - 259
DELPHINIUM	decòrum	✓ New California - - - 11		ròsea	○ Himalayas - - - 324
<i>Berberidéa.</i>			<i>Oxalidéa.</i>		
BÉRBERIS	Coriària	✱ Nepal - - - 557	O'XALIS	lasiàndra	✓ Δ Mexico - - - 558
<i>Papaveràcæa.</i>			<i>Rutàcæa.</i>		
PAPAYER	commutàtum	○ Siberia - - - 167	BORONIA	triphýlla	✱ □ New Holland - 558
<i>Capparidàcæa.</i>			<i>Celastrínæa.</i>		
ISOMERIS	arbòrea	✱ □ California - - - 11	ELEODENDRON	capènsè	♀ □ Cape of Good Hope - 11
<i>Violariàcæa.</i>			<i>Leguminòsæa.</i>		
SCHWEIGGÈRIA	pauciflòra	✱ □ Brazil - - - 557	BOSSIA	tenuicaulis	✱ □ Van Diemen's L. - 558
<i>Pittosporàcæa.</i>				dísticha	✱ □ Swan River - - - 558
MARIAINTUS	cæruleo-punctàtus	♂ □ S. River - 557	CALLISTACHYS	lineàris	✱ □ Swan River - - - 558
<i>Malvàcæa.</i>				longiflòra	✱ □ Swan River - - - 259
HIBISCUS	Telfairiæ	✱ □ Mauritius - - - 259	CHOROZEMA	spectàbile	♂ □ Swan River - - - 558
	Wràzæ	✱ □ Swan River - - - 11	CLIAINTUS	cárneus	♂ □ Philip's Island - - 59
MA'LVÀ	laterfítia	✓ Δ Buenos Ayrcs - 61	DAUBENTONIA	Tripetàna	✱ □ Buenos Ayrcs (25)
SI'DA (ABUTILON)	Bedfordiàna	♂ Δ Brazil - - - 558	ÍNDIGO'FERA	stipulàris	✱ □ South Africa - - 11
<i>Geraniàcæa.</i>			LA'THYRUS	tomentòsus	Δ Buenos Ayrcs - 167
GERANIUM	rubifòlium	✓ Δ Himalayas - - 11	MIRBE'LLA	floribúnda	✱ □ Swan River - - - 559
<i>Tropæolàcæa.</i>			ZI'CHYA	panòsæa	♂ □ Swan River - - - 559
TROPÆOLUM	Moritziànum	Δ Cumana - - - 61			



<i>Rosaceæ.</i>		<i>Boraginææ.</i>	
POTENTI'LLA		ANCHU'SA	
insignis $\nabla$ $\Delta$	Nepal - - - 559	petiolata $\Delta$	Nepal - - - 260
SPIRE'A		CYNOGLO'SSUM	
kamtchatica var. himalensis $\nabla$ $\Delta$	H. 62	glochidiatum $\bigcirc$	India - - - 260
<i>Onagræcæ.</i>		<i>Solanæcæ.</i>	
FUCHSIA		GRABOW'SKIA	
corymbiflora $\text{⌘}$ $\perp$	Peru - - - 12	duplicata $\text{⌘}$ $\square$	Peru - - - 13
<i>Melastomæcæ.</i>		SOLA'NUM	
MARCE'TIA		jasminoides $\text{⌘}$ $\perp$	South America - 168
decussata $\text{⌘}$ $\square$	Brazil - - - 357	macrantherum $\text{⌘}$ $\text{⌘}$	Mexico - 168
<i>Crassulæcæ.</i>		vestitum $\text{⌘}$ $\square$	Mexico - 13
ECHVE'RIA		<i>Scrophularinææ.</i>	
lurida $\Delta$	Mexico - - - 62	ANGELO'NIA	
<i>Stylidææ.</i>		cornigera $\square$	Brazil - - - 62
STYLI'DIUM		PAULOW'NIA	
ciliatum $\nabla$ $\Delta$	Swan River - - 559	imperialis $\nabla$	Japan - - - 62
Drummondii $\nabla$ $\Delta$	Swan River - - 260	<i>Labiatæ.</i>	
<i>Rubiæcæ.</i>		GARDOQUI'A	
POSOQUE'RIA		betonicoides $\nabla$ $\Delta$	Mexico - - - 260
versicolor $\text{⌘}$ $\square$	Cuba - - - 325	ORTHOSI'PHON	
<i>Compósitæ.</i>		incarnvum $\square$	Silhet - - - 63
BRACHY'COME		SA'L'VIA	
iberidifolia $\bigcirc$	Swan River - - 167	hians $\text{⌘}$ $\Delta$	Cashmere - - - 561
CALE'NDULA		regia $\text{⌘}$ $\perp$	Mexico - - - 260
Asterias $\bigcirc$	North of Europe - 13	tubifera $\text{⌘}$ $\perp$	Mexico - - - 561
HELICHRYSUM		SCUTELLA'RIA	
niveum $\nabla$ $\Delta$	Swan River - - 259	japonica $\nabla$	Japan - - - 260
spectabile $\bigcirc$	Swan River - - 560	<i>Verbenæcæ.</i>	
MONOLO'PIA		CHASCO'NUM	
majior $\bigcirc$	California - - - 13	cuneifolium $\text{⌘}$ $\perp$	C. G. H. - - - 14
PODO'LEPIS		<i>Acanthæcæ.</i>	
aristata $\bigcirc$	Swan River - - 259	STROBILA'NTHES	
STE'VIA		scabra $\text{⌘}$ $\square$	India - - - 357
tracheloides $\nabla$	Mexico - - - 259	sessilis $\nabla$ $\square$	India - - - 561
TITHO'NIA		<i>Plumbaginæcæ.</i>	
ovata $\bigcirc$	Mexico - - - 559	ARNE'RIA	
<i>Goodeniææ.</i>		fasciculata $\nabla$ $\Delta$	South of Europe - 260
EU'THALES		<i>Thymelææ.</i>	
macrophylla $\nabla$ $\Delta$	Port Augusta - 62	DA'PHNE	
LECHENAULTIA		japonica $\text{⌘}$ $\perp$	Japan - - - 560
biloba $\text{⌘}$ $\perp$	New Holland - - 560	PIMELE'A	
<i>Gesneriæcæ.</i>		nana $\text{⌘}$ $\perp$	Swan River - - - 14
GLOXY'NIA		spcctabilis $\text{⌘}$ $\perp$	Swan River - - 357
rubra $\nabla$ $\square$	Rio Janeiro - - 62	<i>Orchiidæcæ.</i>	
<i>Ericæcæ.</i>		ANGRÆ'CUM	
PERNE'TTVA		bilobum $\text{⌘}$ $\square$	Cape Coast - - 561
angustifolia $\text{⌘}$	Valdivia - - - 13	glabrifolium $\text{⌘}$ $\square$	Isle of Bourbon - 14
<i>Apocynææ.</i>		BRA'SSIA	
TABERNEMONTANA		Lawrenciana $\text{⌘}$ $\square$	Brazil - - - 261
dichotoma $\text{⌘}$ $\square$	Ceylon - - - 560	BURLINGTO'NIA	
<i>Asclepiadæcæ.</i>		rigida $\text{⌘}$ $\square$	- - - - 562
PHYSIA'NTHUS		CATASE'TUM	
auricomus $\text{⌘}$ $\square$	Brazil - - - 560	trulla $\text{⌘}$ $\square$	South America - 357
STEPHANO'TIS		CHV'SIS	
floribunda $\text{⌘}$ $\square$	Madagascar - 168	bractescens $\text{⌘}$ $\square$	Mexico - - - 261
<i>Bignoniæcæ.</i>		CELO'GYNE	
BIGNO'NIA		Cumngii $\text{⌘}$ $\square$	- - - - 325
speciosa $\text{⌘}$ $\square$	- - - - 560	CYMBI'DIUM	
CO'LEA		pubescens $\text{⌘}$ $\square$	Sincapore - - 561
floribunda $\text{⌘}$ $\square$	Madagascar - 260	DENDRO'BIVM	
<i>Cobææcæ.</i>		discolor $\text{⌘}$ $\square$	Java - - - 562
COBCE'A		macrophyllum $\text{⌘}$ $\square$	Manilla - - - 562
stipularis $\text{⌘}$ $\Delta$	- - - - 325	EPIDE'NDRUM	
<i>Pedalnæcæ.</i>		Grahami $\text{⌘}$ $\square$	Mexico - - - 561
MARTY'NIA		calocheilum $\text{⌘}$ $\square$	Guatemala - 561
fragrans $\square$	Mexico - - - 62	E'RIA	
<i>Convolvulæcæ.</i>		armenlaca $\text{⌘}$ $\square$	Philippine Isles - 561
IPOMCE'A		GALEA'NDRA	
bataloides $\text{⌘}$ $\square$	Mexico - - - 560	Devoniana $\text{⌘}$ $\square$	South America - 562
ficifolia $\text{⌘}$ $\Delta$	Buenos Ayres - 260	GONGO'RA	
tyrianthina $\text{⌘}$ $\perp$	California - - 325	bufonia $\nabla$ $\square$	Brazil - - - 63
		LE'LIA	
		acuminata $\text{⌘}$ $\square$	Mexico - - - 325
		ODONTOGLO'SSUM	
		grande $\text{⌘}$ $\square$	Guatemala - - 261
		pulchellum $\text{⌘}$ $\square$	Guatemala - 561

ONCIDIUM					
macranthèrum	☒	☒	Mexico	-	63
monóceras	☒	☒	Rio Janeiro	-	562
Wràye	☒	☒	Mexico	-	168
SOBRALIA					
séssilis	☒	☒	Peru	-	261
<i>Amaryllidacæ.</i>					
BOMAREA					
simplex	☒	☒	Cusco	-	261
CALLITIAUMA					
viridiflorum	☒	☒	Peru	-	261
angustifolium	☒	☒	Peru	-	261
COBURGIA					
coccinea	☒	☒	Cordillera	-	261
trichroma	☒	☒	Andes	-	261
ELISENA					
longipétala	☒	☒	Lima	-	326
HEMANTHUS					
tenuiflorus var. mozámicus	☒	☒	M.	326	
ISME'NE					
viréscens	☒	☒	Cusco	-	168
SPREKELIA					
cybister	☒	☒	Bolivia	-	326
glauca	☒	☒	Mexico	-	261
<i>Cyrtandræcæ.</i>					
ÆSCHYNA'NTHUS					
maculatus	☒	☒	India	-	325
<i>Liliacæ.</i>					
SOWERBÆA					
laxiflora	☒	☒	Swan River	-	168
<i>Bromelacæ.</i>					
PUYA					
heterophylla	☒	☒	Mexico	-	15

## LIST OF PLANTS

## MENTIONED OR TREATED OF IN THE PRESENT VOLUME.

The word "cult." occurring after any species or variety indicates that there is an article on its culture.

A List of Ixias and other Iridææ cultivated by Bernard Saunders, Nurseryman, Jersey	16	Catalogue of the Cacti in the Collection of the Rev. Theodore Williams	-	313
A List of Plants struck from Cuttings in Charcoal	- 155.	A List of Plants in the Jardin des Plantes at Paris	-	394
A List of Plants adapted for a Conservative Wall	- 239	A List of the Plants introduced into Lombardy in 1840	-	565
Abies balsamea	- 182	Anemone cernua	-	167
communis	- 385.	Hepatica	-	522
mucronata	- 386	montana	-	557
Douglasii	- 166	Pulsatilla	-	557
excelsa	- 29	Angelonia cornigera	-	62
gigantea	- 182	ciliata	-	62
monocaulon	- 182	Angræcum bilobum	-	561
Picea	- 507	glabrifolium	-	14
Abutilon pictum	- 558	Anthoxanthum odoratum	-	231
striatum	- 11	Anthyllis Vulneraria	-	469
vitifolium	- 645	Antirrhinum majus	-	401
Acacia Cunninghamii	- 302	Aporum simutum	-	63
platyptera	- 62	Aquilegia glandulosa var.		
subcærulea	- 302	discolor	-	324
Acanthus mollis	- 537	Araucaria excelsa	-	30
Acer coriacum	- 386	imbricata	-	385
cræticum	- 386.	A'rbutus Andræchne	-	352
lobatum	- 386	Arctostaphylos nitida	-	609
monspessulanum	- 389	Aræca montana	-	357
latifolium	- 386	Ariocarpus retusus	-	510
obtusatum	- 389	Arméria fasciculata	-	260
O'palus	- 386	A'rum maculatum	-	490
platanoides	- 389	Arundina bambusæfolia	-	63
Pseudoplatanus	- 506	Arundo Phragmites	-	516
rotundifolium	- 386	Asclepias carnosa	-	223
trifidum	- 386	Aspergillus glaucus	-	329
Achillea Millefolium	- 469	Babidna plicata	-	488
Aconitum japonicum	- 259	Bejaria glauca	-	380
variegatum	- 401	tedifolia	-	380
Aerotriche depressa	- 85	Begonia Drègii	-	325
Adiantum Capillus Veneris	- 538	Berberis aristata	-	557
Æschynanthus maculatus	- 325	asiatica	-	557
Agave americana	- 526	Coriaria	-	557
Ailanthus glandulosa	- 569	dulcis	-	352
Allium Porrum	- 538	empetrifolia	-	334
Allium cordata	- 385	floribunda	-	557
communis	- 385	Bésiera elegans	-	38
glutinosa	- 503	Bétula alba	-	504.
subcordata	- 385	pendula	-	504
Alysine sagittalis	- 480	Bigonia capreolata	-	334.
Alstromeria acutifolia var.		radicans	-	380
punctata	- 326	speciosa	-	560
Alyssum saxatile	- 401	Bolbophyllum flavidum	-	14
Amygdalus communis	- 505	sordidum	-	14
incana	- 352.	Bomarea acutifolia	-	326
Anchusa petiolata	- 260	simplex	-	261
Boronia ledifolia	- 558	triphylla	-	558
Bossia cinerea	- 558	disticha	-	558
tenuicaulis	- 558	Brachycome iberidifolia	-	167
Brachycome iberidifolia	- 167	Brassia Lawrenciana	-	261
Brassia Lawrenciana	- 261	Bromus pratensis	199.	297.
Bromus pratensis	199.		297.	299.
			467.	564
Brugmansia bicolor	- 477	Cactus alata	-	358
Bonium flexuosum	- 26	flagelliformis	-	359
Burlingtonia rigida	- 562	grandiflora	-	359
Buxus sempervirens	- 536	Opuntia	-	122
Cactus alata	- 358	speciosa	-	358
flagelliformis	- 359	truncata	-	359
grandiflora	- 359	Caladium bicolor	-	220
Opuntia	- 122	discolor	-	220
speciosa	- 358	hamatostigmum	-	220
truncata	- 359	pictum	-	220
Caladium bicolor	- 220	per'cile	-	220
discolor	- 220	splendens	-	220
hamatostigmum	- 220	versicolor	-	220
pictum	- 220	Calectasia cyanea	-	10
per'cile	- 220	Caléndula Astéria	-	10.
splendens	- 220	Callistachys linearis	-	558
versicolor	- 220	longifolia	-	259
Calectasia cyanea	- 10	Callistoma sinense	-	401
Caléndula Astéria	- 10.	Callitachya angustifolium	-	261
Callistachys linearis	- 558	viridiflorum	-	261
longifolia	- 259	Camellia japonica var. Al-		
Callistoma sinense	- 401	bèrtii	-	259
Callitachya angustifolium	- 261	Campánula Medium	-	401
viridiflorum	- 261	Campylanthera elegans	-	557
Camellia japonica var. Al-		Canna indica	-	86
bèrtii	- 259	Carex Maizi	-	177
Campánula Medium	- 401	Cárpinus viminea	-	608
Campylanthera elegans	- 557	Cáthamus tinctorius	-	537
Canna indica	- 86	Cássia marilandica	-	483
Carex Maizi	- 177	Castanea vesca	-	505.
Cárpinus viminea	- 608	Catastium barbatum var.		
Cáthamus tinctorius	- 537	proboscideum	-	63
Cássia marilandica	- 483	calosum	-	63
Castanea vesca	- 505.			
Catastium barbatum var.				
proboscideum	- 63			
calosum	- 63			

Ca. cornutum - - - 63.	Dáphne Dauphíni - - - 572	Hédera Hélix - - - 536
laniferum - - - 63	japónica - - - 560	Hedýsarum alpinum - - - 259
laminatum var. ebur-	Dámmara austrális - - - 182	sibiricum - - - 259
neum - - - 63	Datúra álba - - - 86	Helénium Douglássii - - - 10, 13
trúlla - - - 357	férox - - - 86	Helichrysum niveum - - - 259
Ceanóthus azureus - - - 352	Daubentonia Tripetána - - - 259	spectabile - - - 560
velutinus - - - 609	Delphinium decorum - - - 11	Hepática triloba - - - 522
Cèdrus Cedára - - - 165, 273	Dendrobium aciculare - - - 14	Hesperis matronalis - - - 401
Libani - - - 504	calcaratum - - - 14	Hermercallis flava - - - 401
Cérasus Mahaleb - - - 402, 569	discolor - - - 562	Hérbertia pulchella var.
Pádus - - - 402	gemellum - - - 14	carulea - - - 261
vulgaris - - - 505	macrophyllum - - - 562	Hibiscus Rosa sinensis - - - 86
Ceratophyllum demersum - 515	moschatum - - - 14	syriacus - - - 401
Cèrus Ackermanni - - - 512	Deutzia stamfnea - - - 38	Telfairia - - - 259
articulatus - - - 512	Diánthus barbatus - - - 401	Wràya - - - 10, 11
chilensis - - - 512	Dodártia orientalis - - - 632	Hotela japónica - - - 488
cinerascens - - - 512	Doryánthes excelsa - - - 221	Huntleya violacea - - - 168
coccineus - - - 512	Drába præcox - - - 481	Hyacinthus orientalis - - - 537
flagrifórmis - - - 512	Echeveria lúrida - - - 62	Hyoscyamus niger - - - 538
hexagónus - - - 169	Echinocactus turbinifórmis 510	Hydrangea hortensis - - - 222
Mallisoni - - - 512	Elisèna longipétala - - - 326	Iberis umbellata álba - - - 401
Martianus - - - 512	Elaeodéndron capense - - - 11	violacea - - - 401
Northumberlandia	Epiphedra monostachya - - - 385	Flex Aquifolium - - - 507
ovatus - - - 512	Epidéndrum altissimum - - - 561	speciosa - - - 331
pentálophus - - - 512	calochellum - - - 561	Illicium floridanum - - - 334, 382
Schránki - - - 512	Candollei - - - 85	Impatiens cándida - - - 10, 11, 259
Smithii - - - 512	cailiare - - - 14	rosea - - - 61, 324
speciosissimus - - - 512	Gráhami - - - 561	Indigófera stipularis - - - 10, 11
Chascónum cuneifolium - - - 14	viscidum - - - 14	Iponea batatoides - - - 62, 560
Chelone barbata - - - 260	Epimedium macranthum - - - 488	ficifolia - - - 13, 260
Chimonanthus fragrans - - - 352	Massichanum - - - 488	tyrianthina - - - 325
Chorozema spectabile - - - 558	violaceum - - - 488	Isatis tinctoria - - - 469
Chýsis bractescens - - - 261	Epiphyllum truncatum var.	Ismène virescens - - - 168
Cistus ladaniferus - - - 572	violaceum - - - 325	Isomeris arborea - - - 11
Clárkia pulchella - - - 288	Eria armenlaca - - - 561	Jaquemontia pentantha - - - 13
Clématis grata - - - 86	clavicaulis - - - 15	Jasminum revolutum - - - 572
Clíanthus carneus - - - 62, 559	nütans - - - 15	Jatropha Manihot - - - 491
Cnicus tuberosus - - - 92	velutina - - - 15	Juglans nigra - - - 385
Cobæa scandens - - - 10	Erica austrális - - - 334, 382	regia - - - 271, 385, 505
stipularis - - - 325	Irbýana - - - 560	Juniperus communis - - - 538
Cobúrgia coccinea - - - 261	Jacksonii - - - 560	Sabina - - - 536
trichroma - - - 261	mediterranea - - - 572	Jussiaea grandiflora - - - 91
Cœlogyne cristata - - - 562	retorta - - - 560	Justicia Adhatoda - - - 269
Cumingii - - - 325	Tetralix var. Mackaiana 260	Kérria japónica - - - 334, 382
trinervis - - - 325	Euonymus crenatus - - - 608	Lárix communis - - - 506
Còlea floribunda - - - 260	Euphòbia fastuosa - - - 221	pédula Godsalli - - - 182
Comocladia ilicifolia - - - 380	fúlgens - - - 221	europæa - - - 164, 503
Convólvulus floridus - - - 13	helioscopia - - - 469	Lælia acuminata - - - 325
pentanthus - - - 13	Eutérpe montana - - - 357	Lasiopetalum ledifolium - - - 558
scoparius - - - 560	Euthales macrophylla - - - 62	Láthyrus tomentosus - - - 167
Còrnus capitata - - - 572	Fagus sylvatica - - - 502, 506	Láthyrus nobilis - - - 352, 503
máscula - - - 505	atro-rubens - - - 506	Lecheaúlia biflora - - - 560
Coronilla vária - - - 469	Férula communis - - - 537	fortosa - - - 400, 560
Cotoneáster bacillaris - - - 608	tingitana - - - 485	Leycesteria formosa - - - 9
microphylla - - - 334, 382	Festica ovina - - - 401, 467	Ligústrum vestitum - - - 609
rotundifolia - - - 334, 382	rúbra - - - 467	Lilium cándidum - - - 536
Cratægus apiifolia - - - 391	tenuifolia - - - 469	speciosum var. álbum - - - 562
cordata - - - 391	Urii - - - 564	Limònia Laureòla - - - 608
mexicana - - - 33, 352	Ficus Carica - - - 505	Linum altissimum - - - 184
Crataea Roxbúrgii - - - 86	coriacea - - - 85	usitatissimum - - - 537
Crinum capense - - - 645	elástica - - - 168	Liparis spathulata - - - 14
Cròcus annulatus Adámicus - 325	Frágaria elátior - - - 229	Lobelia discolor - - - 84
minimus var. - - - 325	moschata - - - 229	Lòdium pratense - - - 470
lagenæfórus var. lacteus	Fráxinus excelsior - - - 504, 506	Lonicera flexuosa - - - 572
lutescens - - - 325	Fúcus nátans - - - 523	Lopèzia miniata - - - 38
Crotalária purpúrea - - - 303	Fúchsia discolor - - - 645	Lophospermum erubescens
Cunninghámia lanceolata - 184.	fúlgens - - - 12	var. spectabile - - - 325
Cuprèssus dísticha - - - 386	Galeándra Devoniana - - - 562	Lýchnis fúlgens - - - 298
glauca - - - 380	Gardoqúba betonicoides - - - 260	Lýcium obovatum - - - 38
sempervirens - - - 503	Hookèrii - - - 260	Lycopodium denticulatum - - - 393
Cúscuta epilinum - - - 84	Gaulthèria odorata - - - 380	Macleaya cordata - - - 488
Cýdonia vulgaris - - - 505	Geranium rubifolium - - - 11	Macleaya aurantiaca - - - 569
sinensis - - - 352	Gésnera atrosanguinea - - - 230	Magnòlia acuminata - - - 352
Cyendches Loddigèsi var.	bulbosa - - - 223	auriculata - - - 352
leucocillus - - - 261	Gladiolus cardinalis - - - 461	conspicua - - - 352
Cymbidium pubescens - - - 561	Glossárrhen pauciflorus - - - 577	grandiflora - - - 352, 416
Cynoglossum glochidiatum - 250	Gloxínia rúbra - - - 62	macrophylla - - - 352
Cyperus fúscus - - - 480	Gnaphálum Stæchas - - - 537	purpúrea - - - 352
lóngus - - - 91	Gonathanthus sarmentosus - - - 369	Soulangèana - - - 352
Cyrtochilum maculatum	Gongórra bufonia - - - 63	tripétala - - - 352, 572
var. eornutum - - - 14	iúlya var. vitellina - - - 63	Mahònia Aquifolium - - - 334
Cýstisus Adami - - - 59	Grabow'skia duplicata - - - 13	Málva fragrans - - - 324
Alschingeri - - - 183	Gròbya galcata - - - 15	lateritia - - - 61
Labrimum - - - 59, 183	Gymnogránma macrophylla 221	odorata - - - 324
purpúreus - - - 59	Hæmáanthus tenuiflorus var.	Mammillària Humbóldtii - - - 510
Weldenii - - - 331	mozámbeicus - - - 326	Parkinsonii - - - 510
	Héchtia stenopétala - - - 221	prolifera - - - 511

M. Schlechtendalii	-	510	P. somniferum	-	537	Posoquëria versicolor	-	325
simplex	-	511	Parolinia ornata	-	177	Potentilla insignis	-	559
uncinata	-	302	Passiflora cœrulea	-	572	reptans	-	538
Marcëtia decussata	-	357	racemosa	-	572	Prímula prænitens	-	222
Mariánthus cæruléo-punc-			quadrangulãris	-	51	Pronaya elegans	-	11
tatus	-	557	Paulow'nia imperialis	-	62	Pronay lusiãnica	-	507
Martýnia fragrans	10. 13.	62	Pentstëmon barbatus	-	260	rotundifolia	-	330
Matricãria Maudiãna	-	298	Peristylus Goodyeroides	-	14	Psidium Cattleyãnum	-	51
Maxillãria Dèppei	-	85	Pernettia angustifolia	-	13	Pteris serrulata	-	221
macrophylla	-	14	phyllyreifolia	-	13	Punica Granatum	-	505
Medicagõ falcata	-	469	Përsica vulgaris cult.	63. 505		Pÿga Altenstefnii	-	84
Melocactus communis	-	512	Petunia nyctageniflora	10. 401		heterophylla	-	15
Menziesia empetrifolia	-	13	phenicea	10. 401		Pÿrus aucuparia	-	503
Mëspilus germanica	-	356	Philippodendron rëgium	-	389	communis	-	504
Michaëxia campanuloides	-	488	Phœnix dactylifera	-	503	salicifolia	-	278
lavigata	-	488	Pholidota conchoidëa	-	15	Mãlus	-	504
Micròstylis histionantha	-	84	imbricata	-	15	Sòrbus	-	332
Mirbëlia floribunda	-	559	Phylla ericoides	-	400	Quercus alba	36. 203. 391. 641	
speciosa	-	559	Physiánthus auricomus	-	500	apennina	-	391
Monachánthus discolor var.			albens	-	560	australis	-	386
Bùshnani	-	4	albicans	-	645	Banisteri	-	37
Monolopia major	10. 13.	62	Picea excelsa	-	503	coccinea	-	203
Morus alba	-	505	pectinata	-	166	E'sculus	-	391
Musa Cavendishii	50. 201.	334.	Pimelëa nana	-	14	fastigata	-	37
paradisaca	-	430	spectabilis	-	63. 357	fastigiata	-	641
sapiëntum	-	490	Pinus alopecuroidëa	-	184	heterophylla	-	36. 380
superba	-	168	apulensis	-	182	Flex	-	271. 274. 386
Muscãri comdsum	-	469	austriaca	-	29	lyrata	-	37
Myosotis palustris	-	537	australis	184. 386		macrocarpa	-	36
Mýrtus communis	-	503	Banksiãna	-	28	nigra	-	36
Neracissus poëticus	-	537	brütia	-	28	obtusiloba	-	37
Nelumbium speciosum	513. 557		calabrica	-	386	palustris	-	37. 203
Nigëlla arvensis	-	534	carpatica	-	29	pedunculata	31. 291. 301	
dama-scena	-	534	Cëmbra	386. 402		Phëlos	-	36. 93
hispanica	-	534	Devoniãna	-	182	Prinus discolor	-	36
sativa	-	534	excelsa	153. 165		monticola	-	36
Notýlea sagittifera	-	369	halepënsis	-	28	Pseudò-Süber	-	385
Nuttállia digitata	-	488	Hartwëgii	-	182	pubescens	-	93. 386
malverfolia	-	488	inops	-	29	rùbra	-	36. 203
Nymphæa alba	-	514	japonica	-	182	Ròbur	-	502
lutea	-	514	Lambertiãna	-	429	sessiliflora	31. 203. 301. 400.	
Obeliscaria Drummondii	-	168	Laricio	28. 402		incana	-	403
Odontoglossum biconcense	-	14	leiophylla	-	182	pubescens	-	386
Ehrenbërgii	-	369	macrophylla	-	182	Skinneri	-	609
grande	-	261	maritima	-	380	Taxin	-	391
pulchëllum	-	561	Montezumæ	-	182	tinctoria	-	37. 204
Ænothëra fruticosa var. fu-			mitis	-	28	virens	-	93. 476
dica	-	167	nigrëscens	-	639	Raffësia Arnöldii	-	187
O'lea europæa	-	505	occarpa	-	182	Rãphanus caudatus	-	86
Olinia capensis	-	84	occarpoides	-	609	Rhãmus catharticus	-	538
Oncidium carthaginense	-	84	Pallasiãna	-	29	Rhëum palmatum	-	488
macranthërum	-	63	palustris	-	386	Rhëxia decussata	-	357
macrochilum	-	14	excelsa	-	182	Rhododendron arbdreum	-	184
monóceras	-	562	Pinãster	29. 271		dãuricum	-	462
pelicanum	-	14	Pinea	-	29	atrovirens	-	462
reflexum	-	14	pityusa	-	182	ferrugineum	-	462
Wentworthianum	-	14	ponderosa	-	165	hirsutum	-	462
Wryax	-	168	Pseudò-Stròbus	-	182	Rhodorhiza scoparia	-	560
Onopordum Acanthium	-	469	pumilio	28. 183. 402		Rhùs Còtinus	-	572
Opuntia cylindracea	-	513	pungens	-	29	Ribes sanguineum	-	231
decipiens	-	513	pyrenæica	-	28	speciosum	-	572
excuvata	-	513	resinosa	-	28	Robinia glutinosa	-	391
hòrrida	-	380	rumæna	-	386	Pseud-Acacia	-	391
imbricata	-	513	Russeliãna	-	182	viscosa	-	572
Stapëlia	-	513	serotina	-	184	Roderiguëzia maculata	-	15
tunica	-	513	sinënsis	-	28	Ròsa devoniënsis	-	559
vulgaris	-	359	Stròbus	29. 402. 507		indica	-	86
Origanum Majorana	-	536	sylvëstris	28. 386. 400. 402.		Jundona	-	536
Orthosiphon incervus	-	63	uncinata	-	28	Roscœa purpurea	-	645
O'xalis Acetosella	-	645	variabilis	-	29	Rùbus trilobus	-	609
decaphylla	-	558	Webbiãna	-	166	Rudbeckia Drummondii	-	168
fruticosa	-	558	Pisonia Olfersiãna	-	369	Rùmex maritimus	-	480
Hernandësii	-	558	Plátanus orientalis	-	504	Salisbùria adiantifolia	182. 352	
lasiandra	-	558	occidentalis	93. 274. 403		Sãlix alba	-	507
Ottónis	-	84	Pleurothállis lutëola	-	63	babylónica	-	503
Pæonia Moutan	488. 572		recurva	-	63	Salsòla Kãli	-	115
officinãlis	401. 534		Plumbago capensis	-	223	Sãlvia amœna	-	561
speciosa striata	-	378	Podòlepis aristata	-	260	confertiflora	-	561
anemoneflora stri-			Polýgonum volcãnicum	-	609	hians	-	561
ata	-	378	Polystachya cœrea	-	15	lamiifolia	-	561
élegans	-	378	Pòpulus alba	-	291	pãtens	-	301
lutea variegata	-	378	fastigiata	-	385	prunelloides	-	10. 14
pulchërrima	-	378	heterophylla	-	385	règla	-	13. 260
Victorie Modeste	-	378	monilifera	-	400	tubifera	-	561
Pancrãtium ringens	-	326	trémula	-	507	Sargassum vulgare	-	524
Papàver commutatum	-	167	Portulacæa oleracæa	-	538	bacciferum	-	524

Scabiosa arvensis - - -	469	Státice pectinàta - - -	14	Triplèolium spinòsum - - -	259
Schizánthus Evansiàmus - - -	561	Stephanòtis floribúnda - - -	168	Tríficum repens - - -	504
pinnátus - - -	561	Stèvia tracheliòides - - -	259	Tropæòlum Moritziànum - - -	61.
Schweigèria pauciflòra - - -	557	Strebilòiza speciòsa - - -	62. 559		369
Scòlymus hispànicus - - -	391	Streptocàrpus Rèxi - - -	223	Tùlipa pàtens - - -	562
Scutellària japònica - - -	260	Strobilánthes scàbra - - -	357	tricolor - - -	562
splèndens - - -	369	sésilis - - -	561	Tussilàgo odoràta - - -	1
Sida Bedfordiàna - - -	558	Stylidium Drummondii - - -	260	Ulmus campèstris - - -	356. 506
picta - - -	11	ciliàtum - - -	559	latifolia - - -	391
Sobràlia sésilis - - -	261	Symphòria glomeràta - - -	230	effusa - - -	93. 389
Solànum carolinianum - - -	632	Syringa Emòdi - - -	608	montàna - - -	391. 506
dulcamaròides - - -	168	Taberna montàna dichòtoma - - -		glàbra - - -	32
jasminòides - - -	168	560		Vaccinium Myrtillus - - -	183
macranthèrum - - -	168	Tàgetes erècta - - -	537	Valeriàna rubra - - -	401
vestitum - - -	13	Tàmariæ ericòides - - -	86	Verbèna, Melindris - - -	14
Sophòra japònica pèndula - - -	289	gàllica - - -	536	Verònica hederæfolia - - -	480
Sowerbæa laxiflòra - - -	168	Tàxus baccàta - - -	504	virginiana - - -	401
jàncea - - -	168	Thomásia canescens - - -	11	Vicia Fàba - - -	537
Spàrtium multiflòrum - - -	572	Thùja articulàta - - -	227	Vinea minor - - -	536
Spiræa bèlla - - -	488	occidentàlis - - -	507	Viola odoràta - - -	536
Filipèndula rubra - - -	298	Thýmum Seryphyllum - - -	469	tricolor - - -	537
kamtchática - - -	62	Tilia europæa - - -	271. 274. 504	Vitex A'gnus cástus - - -	536
vacciniifolia - - -	488	rubra - - -	506	Vitis vinifera - - -	505
Sprekèla cinnabàrina - - -	326	Tilàndsia usneoides - - -	477	Zichya pannòsa - - -	559
cystifer - - -	326	Tithonia ovàta - - -	559	tricolor - - -	559
formosissima - - -	326	Trachelium cæruleum - - -	223	Zygopètalum africànum - - -	14
glauca - - -	261. 326				

## LIST OF FRUITS.

Apples : —		Grapes <i>continued</i>		Pines, - <i>cult.</i> 17. 51. 201. 234. 387	
Sweet and Sour - - -	476	Frankenthal - - -	5	Black Jamaica - - -	53
Bananas - - -	492	Grizzly Frontignan - - -	48	Enville - - -	21. 387
Bérberis dulcis - - -	586	Madeleine - - -	404	Providence - - -	21
Cherries : —		Muscat - - -	402	Queen - - -	53. 231
Napoleon - - -	391	of Alexandria - - -	5. 24. 48. 387	Plantain - - -	50. 201. 334. 387. 430
New one described - - -	330. 569	Royal Muscadine - - -	5. 26	Plums : —	
Currants - - -	564. <i>cult.</i> 573	Sweetwater - - -	23. 24	Green Gage - - -	416
Figs - - -	37. <i>cult.</i> 375	Syrian - - -	26	Ickworth Impératrice - - -	614
Fáchsia fulgens - - -	648	Tripoli - - -	26	Old Impératrice - - -	614
Guava - - -	51. 234	West's St. Peter's - - -	26	Quince - - -	564
Gooseberries - - -	391. 465. 521.	White Frontignan - - -	5	Raspberries, - - -	465
<i>cult.</i> 573		White Muscadine - - -	48	Strawberries, - <i>cult.</i> 39. 56. 229	
Granadilla - - -	51	Wilmot's New Hamburg - - -	614	Alpine - - -	39. <i>cult.</i> 266. 387
Grapes - - -	45. 47. 48. 73. 96. 262. 334. 571	Melons - - -	53. <i>cult.</i> 465	Bishopwick - - -	614
Black Clutess - - -	5	Nectarines : —		Carolina Pine - - -	40
Black Hamburg - - -	5. 26. 48. 402. 614	Select List of - - -	66. <i>cult.</i> 361. 574	Downton - - -	40
Black July - - -	404	Orange - - -	93. 400. 427	Hautbois, - - -	<i>cult.</i> 266
Black Muscat - - -	5	Peaches - - -	63. 321. 571	Keen's Seedling - - -	39.
Chasselas - - -	387. 402	Select List of - - -	67		<i>cult.</i> 264
Musque - - -	26	Late Admirable - - -	614	Myatt's British Queen - - -	614
Corinth - - -	404	Walburton Admirable - - -	614	Eliza - - -	614
Damascus - - -	24. 26	Pears - - -	464	Pine - - -	648
Dutch Black Hamburg - - -	26	Dunmore - - -	614	Newsam's Princess Royal - - -	614
Dutch Sweetwater - - -	26	Flemish - - -	615	Roseberry - - -	39
Esperione - - -	26	Groom's Princess Royal - - -	614	Swanston Seedling - - -	614
		Marie Louise - - -	614	Wellington - - -	39
				Wilmot's Superb - - -	40
				Wilmot's Victoria - - -	614

## LIST OF CULINARY VEGETABLES.

Asparagus - - -	648	Celery : —		Onion - - -	88. 185
Marshall's dwarf Pro- lific - - -	614	Bailey's Gigantic - - -	76	Oxalis Dépezi - - -	614. 648
Beans - - -	74	Kentucky - - -	76	Parsnep - - -	79
Mazagan - - -	614	Law's Giant - - -	76	Peas - - -	74. 375
Cabbage : —		Manchester Giant - - -	76	Milford Marrow - - -	614
Mammoth - - -	330	Perkins's Large - - -	76	Potatoes - - -	329
Carrot : —		Russian Pink - - -	76	Sourmilier - - -	331
Altringham - - -	80	Seymour's Red Solid - - -	76	Radish : —	
Altringham long Orange - - -	28	Superb White - - -	76	Java - - -	86
Early Horn - - -	27. 80	Siberian - - -	76	Rhubarb - - -	75. <i>cult.</i> 174
New White Altringham - - -	28	Comfrey - - -	648	Victoria - - -	648
Surrey long - - -	28	Cucumber - - -	35. 53. 90. <i>cult.</i> 262. 563	Scarlet Runners - - -	211
White or Belgian - - -	80	Mushrooms - - -	227. <i>cult.</i> 328. 526	Sea-kale - - -	75. <i>cult.</i> 269

## LIST OF AGRICULTURAL PLANTS.

Barley - - - - 410	<i>Festuca U'rii</i> - - - 564	Oats - - - - 410
Bokhara Clover - - 231	<i>Lolium pratense</i> - - 470	<i>Trifolium incarnatum</i> - 648
<i>Bròmus pratensis</i> - - 467. 564	Lucern, an early variety - 587	Turnips - - - - 410. 476
<i>Festuca ovina</i> - - - 467	Mangold Wurzel - 342. 519	Wheat - - - - 275. 410. 475
<i>rùbra</i> - - - - 467		

## LIST

## OF HORTICULTURAL, BOTANICAL, AND FLORICULTURAL SOCIETIES.

Agricultural and Horticultural Society of India - 593	Highland and Agricultural Society of Scotland - - 458	Prussian Horticultural Society - - - - 357
Bath Royal Horticultural and Botanical Society - 283	London Horticultural Society and Gardens - - 331	Swansea and Neath Horticultural Society - - 577
Doberan Agricultural and Silvicultural Society - 592	North Bristol Gardener's Society - - - - 21	Yorkshire Horticultural and Floral Society - - - 577

## LIST OF GARDENS AND COUNTRY SEATS.

Abbotsford - - - - 369	Chatsworth - 40. 45. 92. 234.	Gillingham Hall - - - 273
Alton Towers - 41. 207. 368.	239. 333. 382. 420	Gunnorsbury Park - - - 77
393. 496	Childwall Hall - - - 365	Gunthorpe Hall - - - 272
Annatt Cottage - - - 477	Claremont - - - 239. 250	Gunton Park - - - 31
Arboretum:—	Clifton Park - - - 356	Haile's Abbey - - - 419
Derby - - - - 381	Colney House - - - 237	Hampton Court - - - 415
Flitwick - - - - 36	Corsham House - - - 366	Ham Green - - - 525
Arlington Court - - - 571	Cossey Hall 26. 79. 96. 218. 467	Haverland Park - - - 32
Ashridge - - 27. 76. 356. 365	Cromer Hall - - - 31	Hendon Vicarage - - - 313
Barningham Park - - - 30	Dalkeith Gardens - - - 280	Henham - - - - 355
Baring Park - - - 238	Dalvey - - - - 166	Heydon Park - - - 33
Bayfield Hall - - - 272	Ditchingham House - - 273	Honing Hall - - - 272
Beeston Park - - - 272	Donnington Park - - - 365	Horsford Hall - - - 31
Belvoir Castle - - - 365	Downton Castle - - - 366. 376	Houghton Park - - - 271
Bicton - - - - 68	Dropmore - - - - 259	Hoveton Park - - - 33. 271
Biggar Park - - - 439	Dunmarle Gardens - - - 465	Hungerton Hall - - - 73
Bittiswell Hall - - - 312	Earsham Park - - - 273	Hunstanton Park - - - 271
Blair-Adam Gardens - 462. 465	Eastnor Castle - - - 367	Hyde Park - - - - 422
Blair-Drummond - - - 505	Eatington Park - - - 324	Jardin des Plantes - 239. 393
Blenheim Palace - - - 34	Eaton Hall - - - - 366	Kenwood - - - - 383
Blickling Park - - - 29	Elvaston Castle - - - 217	Kew - - - - 363
Blithewood - - - 422	Erskine House - - - 257. 434	Kinfauns Castle - - - 477
Bohemia Park - - - 593	Esholt Hall - - - - 610	Kinlet - - - - 573
Bootton Hall - - - 31	Felbrigg Park - - - 31	Kirby Cane Hall - - - 273
Botanic Gardens:—	Felthorpe Park - - - 31	Knowsley Hall - - - 563
Bartram's - - - - 380	Foxley - - - - 367	Knyperley - - - 261
Bath - - - - 283	Gadebridge - - - - 76	Lemon Hill - - - 422
Berlin - - - - 379. 479	Gardens:—	Letton Park - - - 272
Birmingham - 11. 13	Baron Rothschild - 298	Losset Hall - - - - 238
Chelsea - - - - 266	Bryan, Captain George 75	Lowther Castle - - - 367
Glasgow - - - 61. 231	Caledonian Horticultural 7	Margam - - - - 368
Glasnevin - - - 284	Count Castiglioni - 182	Mawley Hall - 173. 264. 274. 478
Hull - - - - 190	Cunningham, Alexander,	Melbury Park - - - 210
Liverpool - - - 38	Esq. - - - - 6	Merivale Hall - - - 231
Munich - 152. 154. 219. 305	Dartford - - - - 334	Monte Video - - - 424
Newburgh - - - 147	Davidson, Henry, Esq. 7	Neuilly - - - - 388
Oxford - - - - 432	Henslow, Professor - 281	New Hall - - - - 561
Rouen - - - - 290	Kensington - - - 331	Nurseries:—
Royal Dublin - - - 184	London Horticultural 62.	Bagshot - - - - 12
Boyton - - - - 92	Luxembourg - - - 331	Bayswater - - - 260. 560
Brantingham Hall - - 76	Madame de Pompadour 406	Berkhampstead - - 77
Brooke Hall - - - 273	Palais Royal - - - 198	Bertin's - - - - 59
Brooke House - - - 273	Tuilleries - - - 198	Cambden - - - - 325
Bury Hill - - - - 259. 564	White. —, Esq. - 3	Cunningham's - - - 357
Cally - - - - 8	Garnstone - - - - 345	Dartford - - - - 563
Carlton Hall - - - 77. 356	Gifford's Hall - - - 286	Durham Down - - - 14. 26
Castle Hill Gardens - - 262		Epsom - - - - 62. 168

Nurseries — <i>continued</i> .	Penrhyn Castle	- - - 367	Stourhead	- - - - 413
Exeter - - - 58. 62. 86. 559	Plumstead Hall	- - - 272	Syon	- - - 76. 260. 357. 560
Exotic, King's Road - - - 346	Prestonfield	- - - 439	Theobald's	- - - 92
Forres - - - 164	Raby Castle	- - - 574	Tidworth House	- - - 232
Henderson's	Rackheath Park	- - - 271	Toddington	- - - 363
Hereford - - - 572	Ragley	- - - 323	Tong Castle	- - - 365
Jersey - - - 15	Raveningham Hall	- - - 274	Trentham	- - - 42
Kensington - - - 231. 278	Ravensworth Castle	- - - 363	Versailles	- - - 333
Milford - - - 11. 13. 239	Redborne Hall	- - - 77	Versailles, Palace of	- - - 17
M. Fion's	Rose Hill	- - - 76. 255	Waltham House	- - - 424
M. Tripet Leblanc	Salt Park	- - - 33	Welbeck	- - - 279
Pope's	Seane	- - - 237. 477	Wentworth House	- - - 387
Prince's	Scottow Park	- - - 33	Westwick Park	- - - 32
Rollison's	Seething Hall	- - - 273	Whitfield	- - - 344
Stanhope	Shirley Park	- - - 37	Windsor Castle	- - - 367
Stanwell	Shotesham Park	- - - 273	Witton Park	- - - 272
Victoria	Shrubland Park	- - - 377	Wolterton Park	- - - 30
Wakefield	Spixworth Park	- - - 271	Worstead House	- - - 272
Western	Spofforth	- - - 261. 326	Wrest Park	- - - 362
Oakfield Lodge	Spruston Lodge	- - - 33	Wroxham Hall	- - - 271
Oatlands	Spruston Park	- - - 271	Wroxham House Park	- - - 271
Oulton Park	St. Cloud	- - - 389	Yester Gardens	- - - 332
Pain's Hill				

## LIST OF BOOKS REVIEWED OR NOTICED.

- Alison's Principles of Population, 294.  
 Anon. A Selection from the Physiological and Horticultural Papers of the late Thomas Andrew Knight, Esq., 327.  
 Anon. Annual Report of the Royal Cornwall Polytechnic Society, 177. 626.  
 Anon. Annual Report of the Committee of National Monuments and Works of Art, 627.  
 Anon. Berlin Horticultural Transactions, 38.  
 Anon. Botanical Labels for the Herbarium, 229.  
 Anon. Companion to the British Almanack for 1841, 84.  
 Anon. Garten Zeitung, 152. 219. 252. 302. 479. 486. 490. 510. 513. 527.  
 Anon. Jameson's Journal, 278.  
 Anon. Journal of the Royal Agricultural Society, 79. 625.  
 Anon. Journal of the Royal Asiatic Society of Bengal, 359.  
 Anon. The Journey-Book of England, 628.  
 Anon. The Kitchen Garden, from the British Almanack, 625.  
 Anon. Mechanic's Magazine, 278.  
 Anon. Penny Cyclopadia, 460.  
 Anon. Quarterly Journal of Agriculture, 119. 138. 295. 438.  
 Anon. The British Almanack for 1841, 34.  
 Anon. The British Farmers' Magazine, 626.  
 Anon. The Field, the Garden, and the Woodland, 326.  
 Anon. Transactions of the Pennsylvania Horticultural Society, 176.  
 Anon. Transactions of the Prussian Horticultural Society, 37.  
 Anon. Transactions of the Society of Arts, 274.  
 Anon. Vegetable Physiology, 327. 616.  
 Antoine's Conifera, 28. 624.  
 Austin and Seely's Specimen Book of Sculptural Works in Artificial Stone, 370.  
 Ayre's Treatise on the Cucumber, 327.  
 Bailey Denton's Model Mapping, 625.  
 Bainbridge's Flower Garden, 628.  
 Brande's Dictionary of Science, 177. 626.  
 Britton's Graphic Illustrations, &c., of Toddington, Gloucestershire, 362. 418.  
 Carter's Catalogue of Seeds for 1841, 177.  
 Curtis's Botanical Magazine, 10. 61. 167. 258. 324. 357. 557.  
 Daubeny's Lectures on Agriculture, 270.  
 Davy's Agricultural Chemistry, 96.  
 De Candolle's Description d'une Nouvelle Espèce de Figuiér, 85.  
 De Candolle's Huitième Notice sur les Plantes Rares, &c., 85.  
 Downing on the Theory and Practice of Landscape-Gardening, 421. 472.  
 Duncan's Treatise on the Cucumber, 274.  
 Edwards's Botanical Register, 10. 61. 167. 258. 324. 357. 557.  
 Fowd's and Lymburn's Catalogue of Plants, 33.  
 Gardener's Chronicle, 245.  
 Germain's Observations sur quelques Plantes Critiques des Environs de Paris, 177.  
 Graham's Catalogue of Plants growing in Bombay, 85.  
 Gregory's Catalogue of Plants, &c., 33.  
 Grigor's Eastern Arboretum, 29. 270. 624.  
 Gulliver's Plants of Banbury, 625.  
 Harrison's Floricultural Cabinet, 16.  
 Harvey's British Alga, 625.  
 Hoffland's Description of White Knights, 157.  
 Jamin's Catalogue des Arbres Fruitières, 620.  
 Johnson's Farmers' Encyclopædia, 625.  
 Johnson's Farmers' Almanack, 628.  
 Lane and Son's Catalogue of Roses, 624.  
 Leigh's Hints for an Essay on Anemology and Ombrology, 87.  
 Lewis's Kilpeck Church, 627.  
 Liebig's Organic Chemistry, 97.  
 Lindley's Introduction to Botany, 459.  
 Link, Klotzsch, and Otto's Icones Plantarum Rariorum, 84. 369.  
 Loudon's Arboretum Britannicum, 93. 182. 186.  
 Loudon's Architectural Magazine, 427.  
 Loudon's Encyclopædia of Plants, 182.  
 Loudon's Hortus Britannicus, 182.  
 Loudon's Supplement to the Encyclopædia of Plants, 369.  
 Loudon's, Mrs., Ladies' Magazine of Gardening, 61. 167. 259. 557.  
 Lucombe, Pince, and Co's. Catalogue of Conifera, 86.  
 Main's Forest Planter's and Pruner's Assistant, 94.  
 Manning's Book of Fruits, 176.  
 Maund's Botanist, 10. 167. 258. 324. 357. 557.  
 Maund's Botanic Garden, 10. 167. 258. 324. 557.  
 Miles's Treatise on the Cucumber, 229.  
 Newman's Phytologist, 626.  
 Newman's Entomologist, 626.  
 Noad's Lectures on Chemistry, 626.  
 Owen's Home Colonies, 628.  
 Paxton's Magazine of Botany, 10. 61. 167. 259. 324. 557.  
 Pratt's Flowers, and their Associations, 228.

- Rhind's History of the Vegetable Kingdom, 228.  
624.  
Ricanti's Rustic Architecture, 34.  
Riley's Catalogue of Ferns, 176.  
Risso and Poiteau's Histoire Natural des Oranges,  
61.  
Rivers's Hints on Root-Pruning, 625.  
Sckell on Landscape-Gardening, 353. 411. 497.  
536.
- Selby's History of British Forest Trees, 624.  
Sopwith's Improved Levelling Stave, 627.  
Wallich's Flora Asiatica, 38.  
Webb's Notice sur le Parolinia, 177.  
White on the Theories of the Weather Prophets,  
370.  
Young's Catalogue of Plants, &c., 33.

## LIST OF CONTRIBUTORS.

- A. B., 9. 231. A. D., 329. A Gardener out of  
Place, 173. 264. An Amateur Gardener, 574.  
An Amateur Gardener, and Constant Reader,  
47. Anderson, William, 266. An old Sub-  
scriber, 185.  
Babbage, James, 356. Bailey, Thomas, 334.  
Bathurst, Charles, 378. Baxter, W. H., 431.  
Beaton, D., 377. Blake, Thomas, 37. Brown,  
N., 231.  
C., 525. Catus, 235. 430. Catton, J., 328. C. F.,  
378. C. O., 516. Coltswood, 47. 73. Conductor,  
35. 36. 37. 42. 45. 47. 58. 88. 89. 92. 93. 96. 181.  
185. 186. 191. 208. 226. 229. 234. 237. 278. 284.  
287. 330. 331. 332. 334. 350. 356. 378. 383. 430.  
435. 574. 575. 654. Cree, Gavin, 435. 440. 444.  
458. 550. Crumpsale, S. H., 377.  
Downing, A. J., 146. Drummond, James, 515.  
Drummond, W., and Sons, 602. Duncan, James,  
21, 238.  
Eaton, James, 210. Errington, Robert, 170. 255.  
269. 615. Ewing, Charles, 563.  
Fish, John, 237. 345. Fish, Robert, 96. Forrest,  
R., 231. Forsyth, A., 204. 494.  
G. C., 233. G. G., 180. G. J., 212. Glendinning,  
H., 57. 63. G. L. L., 508. Godsall, W., 572.  
Gordon, George, 35. 608. Gordon, W., 265.  
Gorrie, A., 1. 185. Gower, N. Leveson, 237.  
Grey, W. Scurfield, 88. Grigor, John, 164.  
H., 257. Harper, F., 186. H. B., 48. H. C. O.,  
593. H. L. L., 226. 564. H. O., 74. Hodgson,  
Edward, 574. Hope, Thomas, 157. Hutchison,  
William, 321.  
J. B. C., 90. J. B. W., 48. 344. 350. 415. J. D.,  
333. J. G., 346. J. H., 429. J. L., 152. J. M.,  
91. 93. 329. 330. 379. 382. 476. 569. Jones, W.,  
227. J. R., 151. 333. J. S., 334.  
Kendall, Peter, 286. Kent, J. C., 45. Kingston,  
James, 96.
- L., 230. Lambert, A. B., 92. Lauder, S., 376.  
Lawrence, George, 313. Lippold, D. J. F., 37.  
Lymburn, R., 97. 335. 376. 408. 416. Lucas,  
Edward, 219.  
Mackenzie, A., 461. 465. Mackenzie, Peter, 433.  
489. 555. 600. Main, James, 208. Manetti,  
Giuseppe, 183. 567. Massey, M., 17. Mills,  
John, 36. M. L., 252. 302. 564. M'Nab, James,  
jun., 3. Moberley, C., 211. Moore, D., 184.  
284. M. F., 36.  
N., 92. 235. Nash, J., 571. Neubert, M. N., 221.  
Niven, N., 49. 478. N. M. T., 9. 43. 147. 169.  
235. 285. 360. 376. 564.  
Ogle, Henry C., 255. Otto, Edward, 381.  
Parks, J. D., 334. 563. Paxton, Joseph, 45. 234.  
430. Pearson, John, 573. Pearson, William,  
7. Penn, John, 232. Poiteau, M., 58. Pringle,  
R., 355. 356. 610.  
R., 563. R. L., 230. 522. Robertson, David, 75.  
Robertson, John, 92. Rogers, John, 34. Rutger,  
T., 93.  
S., 48. Saul, A., 45. 262. Saul, D., 230. 237.  
Saunders, Bernard, 15. Scott, John, 239. 382.  
Seymour, J., 27. 76. 356. 606. S. H., 329. Shep-  
herd, Henry, 38. Shiels, G., 256. 434. Smart,  
M., 311. S. O., 462.  
T. B., 334. 355. Thompson, Robert, 377. 614.  
Torbrun, Thomas, 308. Torrey, John, 570.  
T. S., 562. T. S. W., 73. T. U. W., 429.  
T. W., 571. 654.  
Vilmorin, M., 457.  
W., 569. Walker, W., 223. Wallace, Jasper,  
464. W. B., 184. W. D., 332. Westwood,  
J. O., 186. W. H., 171. 262. 478. W. H. B.,  
477. Wighton, J., 26. 77. 96. 217. 465. 574. 652.  
Wilson, Robert, 45. 174. 237. Wilson, W., 237.  
Wooster, T., 378. W. P., 312. 535. W. S.,  
190.



THE  
GARDENER'S MAGAZINE,  
JANUARY, 1841.

---

ORIGINAL COMMUNICATIONS.

ART. I. *On preserving Plants through the Winter, by Means of the Temperature of Spring Water.* By A. GORRIE, F.H.S., C.S., &c.

IN the *Gardener's Magazine* for 1830, p. 402., is a short article by me, "On preserving plants in winter by means of the temperature of spring water." Having since made some improvements and fully tested its usefulness, I now send you plans of the frame, well, and adjoining small fishponds. Perhaps they may be admissible into your *Suburban Horticulturist*.

By reference to my article in the *Gardener's Magazine*, it will be observed that I then considered it might be usefully applied by cottagers and others who could not conveniently spare the expence of glass frames: finding, however, that many plants useful or interesting to a more wealthy class could be easily preserved under any temperature however severe in this climate, and to prevent some tender plants from being injured by too much damp arising between the spars formerly used, I had a box or frame formed of zinc, quite water-tight, fitted into a wooden frame at near the top of the zinc, and with glazed sashes to fit.

*Fig. 1.* shows the size of this frame, within which are placed pots containing such flowers as are wished to flower early, such as snowdrops, *Tussilago odorata*, &c., or tender green-house plants, as represented by the section (*fig. 2. a*). A two-light hot-bed frame is placed over this zinc frame, large enough to allow of 6 in. clear of water all round the zinc box. When the pots and plants are put in, the box sinks in the water till the top of the pots are something below the surface of the water without, and thus the box is to that height surrounded by a uniform and regular supply of water at the temperature of  $47^{\circ}$ , which causes a like temperature in the air within the zinc, around the pots. When the temperature falls  $6^{\circ}$  or  $8^{\circ}$  below freezing in the open air, the inner sashes must be put on the zinc frame, which at a higher temperature is not necessary: and, however severe the frost or hoarfrost may be without, the inner frame, being surrounded by water at  $47^{\circ}$  or its evaporation, never has any thing

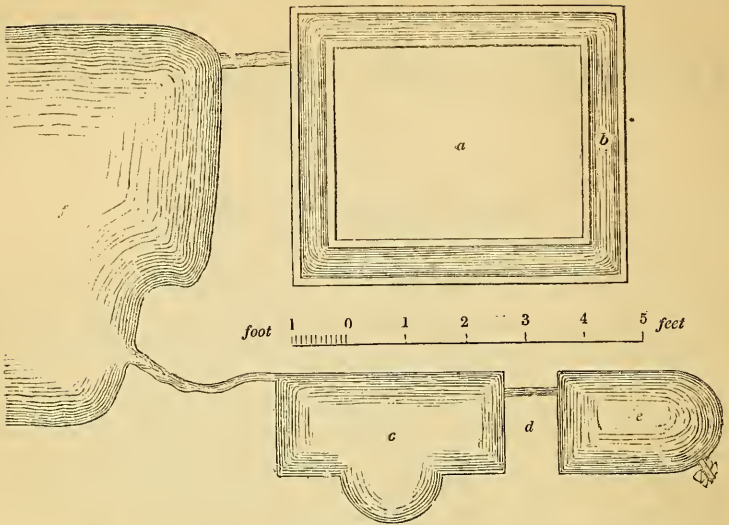

Fig. 1.

## Ground Plan.

*a*, Inner, or zinc-bottomed, frame, betwix which and the outer frame there is a space of 6 inches, *b*, Gold-fish pond. *d*, Footpath. *e*, Gold or silver fish. *f*, Pond for trouts, &c.

like hoarfrost on its glass, and the plants within maintain a healthy appearance.

Geraniums, cinerarias, heliotropiums, &c., continue in a healthy and slowly growing state, quite as fresh as in a conservatory. The small ponds *c* and *e* in *fig. 1*. are fed directly from the well in winter, to communicate warmth to the water in

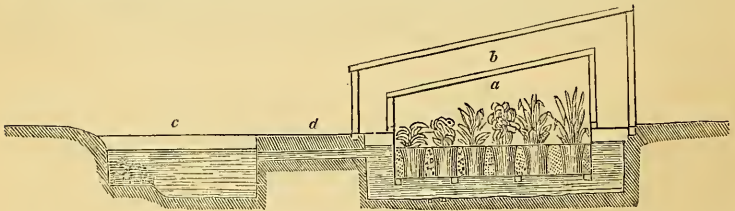

Fig. 2.

## Section.

*a*, Inner zinc frame. *b*, Outer frame. *c*, Small pond for gold or silver fish. *d*, Footpath.

which are gold and silver fish. In summer the water directly from the well would continue at about  $47^{\circ}$  (too cold for the fish); and that it may acquire a higher temperature before it reaches these small ponds wherein are also some rare aquatic plants in pots, the whole water is directed first into the large trout pond with a fall of some inches to prevent the water being too much affected by the low temperature of that in the well; from this it falls into the silver-fish pond *c*, and thence into the gold-fish pond *e*; by this means the trout pond maintains a higher

temperature than the well, and the other two smaller ponds rise higher in temperature in proportion to their distance from the well, and in these the gold and silver fish seem to thrive. All this may appear trifling to the dahlia fancier, but it may be asked whether my water conservatory, with all its appendages, does not afford as much varied enjoyment to a contemplative mind as can arise from gazing on the finest cupped dahlia that ever bloomed; nor do I know of a better situation for keeping autumn struck dahlia cuttings during the winter.

*Annat Cottage, April 18. 1840.*

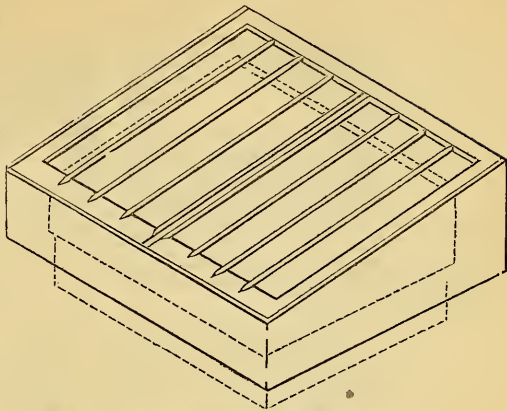

Fig. 3. *Isometrical View.*  
The inner frame is shown by dotted lines.

ART. II. *On the Application of White's Patent Stove to the Heating of Pits and other Plant Structures.* By JAMES M'NAB, jun.

IN compliance with your request to obtain further information regarding the application of White's Patent Stoves to horticultural structures, I beg to say that I proceeded to Haddington on the 7th of April last (1840), in order to witness the various methods which Mr. White has had recourse to for heating houses, pits, &c., with his patent stoves; and, from what I have seen of them during my short visit, I feel pretty confident that they will ere long become generally adopted and useful, provided they be fitted up with care and by qualified individuals. I first examined Mr. White's vinery, figured in the following diagrams to a scale of  $\frac{1}{24}$  in. to 1 foot.

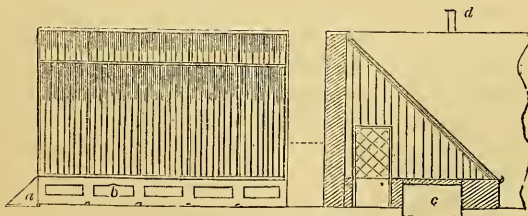

Fig. 4.

*Elevation and End View.*

- a, End view of iron cover over stoke-hole.
- b, Ventilators which open inwards from below.
- c, Front view of iron cover.
- d, Chimney can.

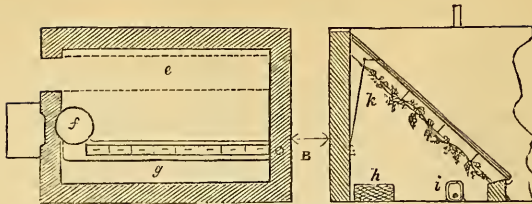

Fig. 5. *Ground Plan and Section.*

*e*, Path. *f*, Stove. *g*, Hot-air flue, with flue covers on. *h*, Grating on cold-air drain.  
*i*, Section of hot-air flue, with smoke tube inside. *k*, Iron rod for raising ventilating sash, the sash shown shut.

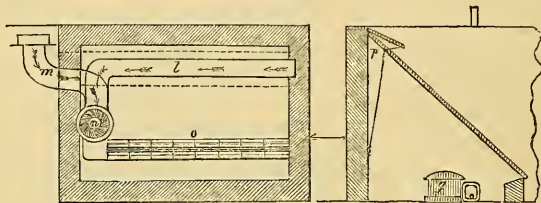

Fig. 6. *Dissected Plan and Section.*

*l*, Cold air drawn below path for inside feeding. *m*, Cold air drawn for outside feeding.  
*n*, Horizontal section of stove, with cover and sand-bath removed. *o*, Hot-air flue, with the covers taken off, showing the smoke tube. *p*, Iron rod for raising ventilating sash, the sash shown open.  
*q*, Stove with its coverings, as seen inside of the house.

During the winter the stove fire has scarcely ever been out; I requested Mr. White to take particular notice of the temperature during the months of December and January, at stated periods, both in and out of doors, and I obtained from him the following observations and particulars regarding its management.

About 4 P. M. the embers in the stove were stirred after being shut up all day; a little coke was then put in and air freely admitted; after being fairly kindled and burning briskly, a little more coke was applied and then regulated for the evening; about 9 P. M. the burning coke was again stirred, the stoves then filled and ventilated according to the appearance of the night. At seven the following morning the temperature was observed both in and out of doors, and the following table will show the result of the observations kept during that period.

With the exception of the 26th of Dec. three of the flue covers were always kept up, but on that night all were down, and the thermometer in consequence fell below 60°. After marking the temperature, a little more coke was given and the stove shut up close for the day. The thermometer in the evenings, when the fire was made up, generally ranged from 65° to 68°.

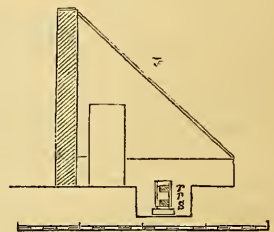

Fig. 7. *End Section, showing Furnace Feeders.*

*r r*, Furnace feeders. *s*, Ash-box.

Observations taken at 7 A.M. during Dec. 1839 and Jan. 1840.

|               | Temperature<br>in Vinery. | Temperature<br>in open Air. |               | Temperature<br>in Vinery. | Temperature<br>in open Air. |
|---------------|---------------------------|-----------------------------|---------------|---------------------------|-----------------------------|
| 1839. Dec. 1. | 60°                       | 36°                         | 1840. Jan. 1. | 65°                       | 38°                         |
| — 2.          | 49                        | 28                          | — 2.          | 65                        | 42                          |
| — 3.          | 55                        | 32                          | — 3.          | 64                        | 40                          |
| — 4.          | 56                        | 34                          | — 4.          | 65                        | 33                          |
| — 5.          | 61                        | 34                          | — 5.          | 64                        | 30                          |
| — 6.          | 61                        | 30                          | — 6.          | 64                        | 29                          |
| — 7.          | 63                        | 31                          | — 7.          | 60                        | 24                          |
| — 8.          | 61                        | 28                          | — 8.          | 66                        | 32                          |
| — 9.          | 62                        | 32                          | — 9.          | 66                        | 34                          |
| — 10.         | 64                        | 34                          | — 10.         | 64                        | 29                          |
| — 11.         | 61                        | 32                          | — 11.         | 61                        | 39                          |
| — 12.         | 64                        | 40                          | — 12.         | 66                        | 42                          |
| — 13.         | 66                        | 41                          | — 13.         | 65                        | 44                          |
| — 14.         | 65                        | 40                          | — 14.         | 63                        | 38                          |
| — 15.         | 60                        | 38                          | — 15.         | 65                        | 44                          |
| — 16.         | 62                        | 36                          | — 16.         | 65                        | 40                          |
| — 17.         | 65                        | 34                          | — 17.         | 64                        | 34                          |
| — 18.         | 63                        | 34                          | — 18.         | 65                        | 33                          |
| — 19.         | 65                        | 37                          | — 19.         | 65                        | 40                          |
| — 20.         | 65                        | 45                          | — 20.         | 60                        | 34                          |
| — 21.         | 68                        | 47                          | — 21.         | 64                        | 41                          |
| — 22.         | 61                        | 46                          | — 22.         | 60                        | 35                          |
| — 23.         | 69                        | 45                          | — 23.         | 61                        | 46                          |
| — 24.         | 65                        | 42                          | — 24.         | 68                        | 30                          |
| — 25.         | 60                        | 38                          | — 25.         | 64                        | 34                          |
| — 26.         | 55                        | 28                          | — 26.         | 62                        | 38                          |
| — 27.         | 63                        | 30                          | — 27.         | 61                        | 31                          |
| — 28.         | 63                        | 27                          | — 28.         | 62                        | 32                          |
| — 29.         | 62                        | 28                          | — 29.         | 60                        | 32                          |
| — 30.         | 64                        | 26                          | — 30.         | 60                        | 31                          |
| — 31.         | 65                        | 45                          | — 31.         | 60                        | 34                          |

On the 16th of Feb. (1840), the following vines were planted in the house, viz. Black Hamburg, White Frontignan, Frankenthal, Royal Muscadine, Muscat of Alexandria, Black Muscat, and Black Cluster. Early in April gentle heat was applied, and the result already proved is very satisfactory.

The small pit (*fig. 8.*) which Mr. White first erected in his garden, and to which a trial of his stove was first applied, had at the period of my visit a plentiful crop of grapes setting well. The pit is 10 ft. long, 5½ ft. wide, and is heated with one

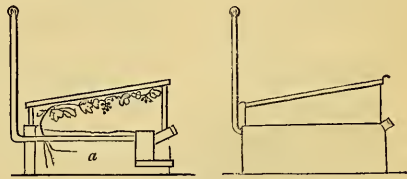
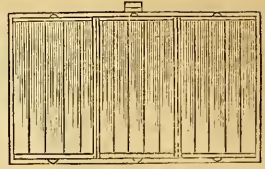

Fig. 8. Section and End Elevation of Mr. White's Vine Pit.

of the small patent stoves, placed at the back part of the pit inside, the feeder being on the outside; the smoke pipe is conveyed under the surface of the soil from the stove to the front of the pit, as

shown in the section, *fig. 8.* at *a.* The treatment used for the small stove was the same as described for the large one, the thermometer in the evenings ranging from  $70^{\circ}$  to  $75^{\circ}$ .

*Fig. 9.* is a vertical profile of this pit with the sashes on.



*Fig. 9.* Vertical Profile of Mr. White's Vine Pit.

I next visited the garden of Alexander Cunningham, Esq. This gentleman is a great enthusiast in horticulture; and, being pleased with this novel method of heating, he agreed to have a range of pits put up, and to be heated with one of the patent stoves on Mr. White's plan. Mr. Cunningham's range is 24 ft. long, 7 ft. 6 in. wide, 3 ft. high at back, and 18 in. in front. It is divided into three spaces, as shown at *a b c*, *fig. 10.* The

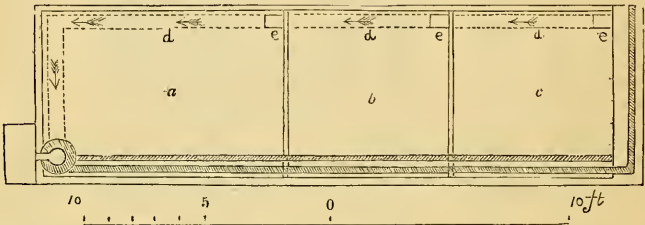

*Fig. 10.* Ground Plan of Mr. Cunningham's Pits for Grapes, Melons, and Peaches.

smoke pipe is of cast iron, which is found to answer much better than the malleable iron ones first used by Mr. White. The pipe is laid in a built flue with movable covers, instead of fire-clay cylinders, as used in Mr. White's vinery. Fire-clay cylinders are more expensive but much neater-looking than the built ones. The stove in Mr. Cunningham's pit is placed at the front or south-west corner, and the heat carried along the front below the level of the soil, as shown in the sections in *fig 11.*

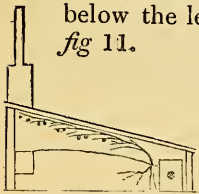

*Pit for Grapes.*



*Pit for Melons.*



*Pit for Peaches.*

The first division of Mr. Cunningham's pit, occupying three sashes, is planted with vines; the next, of two sashes, with melons; and the third, also of two sashes, with peaches. At the period of my visit it was Mr. Cunningham's wish to have most heat in the vine pit; and accordingly two or three of the flue covers were tilted up in it, and one in the melon department; after a while, when less heat will be required for the vines, the covers will be shut down and those in the melon and peach

departments raised a little. The stove employed in this pit is No. 4.; and Mr. Cunningham assures me that two bushels of coke (6*d.* worth) a week is as much as his stove has been able to consume during the severest weather which he has had it going.

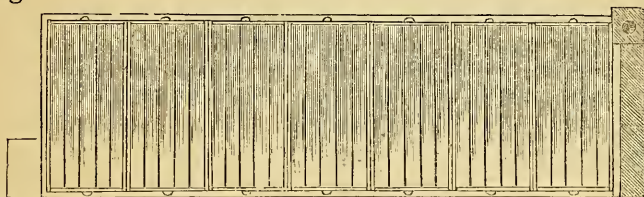

Fig. 12. *Vertical Profile of Mr. Cunningham's Pits, with the Sashes on.*

The next structure visited was a green-house belonging to Henry Davidson, Esq., sheriff substitute, Haddington. The stove and hot-air flue are placed and fed within. Mr. Davidson seems highly delighted with it, both on account of the fuel saved, and the little trouble required for its management, the only objection being the escape of a little dust while cleaning out the stove. As Mr. Davidson's green-house is situated on the top of some out-houses and entered from the lobby of the second floor of his dwelling-house, few other methods of heating could have been contrived to answer the purpose so well.

From what Mr. White has already done in heating horticultural structures with his patent stoves, I feel pretty confident in their success. He is at present engaged fitting up several green-houses and pits in this country, and amongst others a vinery for the Earl of Lauderdale. One of Mr. White's stoves was recently fitted in a green-house erected for Lord Jeffrey, at Craig Crook: the mildness of the weather since its erection has caused it to be little used. Previously, however, to the plants being put in, I saw it thoroughly tested, and the results of a week's trial agree very closely with the observations on Mr. White's vinery.

*Cal. Hort. Soc. Garden, Edinb., April, 1840.*

ART. III. *A Systematic Plan for a Gardener to "serve the Kitchen."*  
By WILLIAM PEARSON.

I BEG leave to submit for your approval or disapproval the accompanying simple plan which I put into practice some years ago, for the purpose of serving the kitchen and the dessert with more facility and regularity than is generally done.

Many of my brethren are well aware of the disagreeable things which almost daily occur between the gardener and the cook in regard to the vegetables, fruit, &c., which often arise





THE DESSERT BILL.

| Names of Articles. | Quantities. | Days of the Month — (August.) |    |    |    |   |    |   |   |   |    |    |    |    |    |    |    |    |
|--------------------|-------------|-------------------------------|----|----|----|---|----|---|---|---|----|----|----|----|----|----|----|----|
|                    |             | 1                             | 2  | 3  | 4  | 5 | 6  | 7 | 8 | 9 | 10 | 11 | 12 | 13 | 14 | 15 | 16 | 17 |
| Pine-apples -      | No.         | 1                             |    |    | 1  |   | 1  |   |   |   |    |    |    |    |    |    |    |    |
| Grapes -           | lbs.        | 3                             | 2  | 4  |    | 6 |    |   |   |   |    |    |    |    |    |    |    |    |
| Peaches -          | No.         | 24                            | 15 |    | 10 |   | 12 |   |   |   |    |    |    |    |    |    |    |    |
| Nectarines -       | No.         | 10                            | 9  |    | 8  |   | 7  |   |   |   |    |    |    |    |    |    |    |    |
| Melons -           | No.         | 1                             |    | 1  |    | 1 |    |   |   |   |    |    |    |    |    |    |    |    |
| Cherries -         | lbs.        | 1                             | 2  | 1½ | 1  | 1 | 1  |   |   |   |    |    |    |    |    |    |    |    |
| Plums -            | lbs.        | 2                             | 2  | 3  | 1½ | 1 | 1  |   |   |   |    |    |    |    |    |    |    |    |
| Gooseberries -     | Pts.        | 1                             | 2  | 1  | 1  | 2 |    |   |   |   |    |    |    |    |    |    |    |    |
| Strawberries -     | Pts.        | 1                             | 1  | 1  | 1  | 1 | 1  |   |   |   |    |    |    |    |    |    |    |    |
| Currants, &c.      | Pts.        | ½                             | ½  | ½  | ½  | ½ | ½  |   |   |   |    |    |    |    |    |    |    |    |
| Ice -              |             | ℥                             |    |    | ℥  |   | ℥  |   |   |   |    |    |    |    |    |    |    |    |

ART. IV. *On Leycesteria formosa*, as an Undergrowth for the Shelter and Food of Game, and as a Sea-Breeze Plant. By N. M. T.

LEYCESTERIA formosa is by no means a splendid plant, but it is, under every circumstance, a striking and very interesting one. Its admirable pendent racemes of flowers and fruit, sheltered by numerous branches and leaves, are so different from any thing we before possessed, that I find them attract universal attention. Its decidedly hardy character, the amplitude of its foliage, the extreme rapidity of its growth, and the ease with which it may be produced from cuttings, layers, or seed, all point it out as an object well calculated to form underwood, or shelter for game. Its worth for such purposes would be doubled, could game be brought to feed upon its berries, which are produced in great profusion. Could its (to me) insipid fruit be converted into any useful domestic purpose, it would, I think, under culture, require the same treatment as the raspberry, as it seems disposed to produce its shoots from the bottom annually.

It seems also to possess in a great degree the valuable property of standing unshrinkingly the saline breeze, whence it may possibly be useful where so many things are really useless. The only seeming objection to its covering what appear to be uncovered wastes is, that it carries too much sail.

Folkstone, Sept. 10. 1840.

ART. V. *Notice of a Petunia of extraordinary Dimensions.* By A. B.

HAVING read in some of the Numbers of the *Gardener's Magazine* notices of the size to which different plants have at-

tained, I send you the dimensions of a *Petunia* placed in the latter end of May 1839, as a cutting (only a few inches high), against a wall facing the south-east. It measured at the end of that year 9 ft. in height, and 13 ft. in breadth; a matting protected it through the winter, and it is now (Dec. 1. 1840) 13 ft. high, and 16 ft. broad. It is trained in the fan shape, and has never ceased presenting throughout the spring, summer, and autumn, a gorgeous mass of the most splendid bloom, until checked by the frosts which set in here (in the hills of Caermarthenshire) early. A cutting, taken from the above *Petunia* in the autumn of 1839, now measures 10 ft. high, by 12 ft. wide. This *Petunia* is a hybrid between *P. nictaginiflora* and *P. phœnicea*; the blossom is large, and of a rosy purple colour, with a dark eye. A *Cobœa scandens* of this year has also reached the height of 20 ft.—*Dolau Cothi, near Llandovery, Dec. 1. 1840.*

---

ART. VI. *Botanical, Floricultural, and Arboricultural Notices of the Kinds of Plants newly introduced into British Gardens and Plantations, or which have been originated in them; together with additional Information respecting Plants (whether old or new) already in Cultivation: the whole intended to serve as a perpetual Supplement to the "Encyclopædia of Plants," the "Hortus Britannicus," the "Hortus Lignosus," and the "Arboretum et Fruticetum Britannicum."*

*Curtis's Botanical Magazine*; in monthly numbers, each containing seven plates; 3s. 6d. coloured, 3s. plain. Edited by Sir William Jackson Hooker, LL.D., &c., Professor of Botany in the University of Glasgow.

*Edwards's Botanical Register*; in monthly numbers, new series, each containing six plates; 3s. 6d. coloured, 3s. plain. Edited by Dr. Lindley, Professor of Botany in the University College, London.

*Maund's Botanic Garden, or Magazine of Hardy Flower Plants cultivated in Great Britain*; in monthly numbers, each containing four coloured figures in one page; large paper, 1s. 6d.; small, 1s. Edited by B. Maund, Esq., F.L.S.

*Paxton's Magazine of Botany, and Register of Flowering Plants*; in monthly numbers; large 8vo; 2s. 6d. each.

*The Botanist*; in monthly numbers, each containing four plates, with two pages of letterpress; 8vo; large paper, 2s. 6d.; small paper, 1s. 6d. Conducted by B. Maund, Esq., F.L.S., assisted by the Rev. J. S. Henslow, M.A., F.L.S., &c., Professor of Botany in the University of Cambridge.

In these notices we may direct attention to the following new plants, which promise to be valuable additions to our gardens. The most important of these is *Fuchsia corymbiflora*, the most splendid fuchsia ever introduced; and next to this is *Hibiscus Wrayæ*, a beautiful Swan River shrub. *Impatiens candida*, *Indigófera stipularis*, *Monolopia major* (the *Helénium Douglássii* of the seed shops), *Caléndula Astèrias*, *Martynia fragrans* and *Sálvia prunelloides*, are also well deserving of attention. To these may be added *Calectàsia cyànea*, a most

beautiful Australian plant, figured in the *Bot. Mag.* t. 3834., but not yet introduced. The flowers are of a most beautiful brilliant blue, and of the kind called everlasting. It grows in sandy soil among shrubs.

*Ranunculaceæ.*

1599. DELPHINIUM [1840, 64., and Bot. Gard. 761.  
decorum *Fisch. et Mey.* decorous ♀ or 1½ my P New California 1838. S co Bot. reg.

This pretty larkspur was first raised in the Botanic Garden, Birmingham, from seeds received from St. Petersburg, it being a native of the Russian settlement of New California in North America. "It is a plant of neat growth," and it appears perfectly hardy; but "at present it does not admit of division of the root." (*Bot. Gard.* and *Bot. Reg.*, Nov.)

*Capparidææ.*

- ISO'MERIS (*Isos*, equal, *meris*, part; regular petals, and equal length of stamens and pistils.)  
arborescens *Nutt.* tree □ ♀ pr 10 my Y California 1839. C co Bot. mag. 3842.

An erect deciduous shrub, with yellow flowers, which have rather a disagreeable smell, and which bear some resemblance to those of the small-flowered *Edwardsia*. It is a native of California, where it was discovered by Nuttall. (*Bot. Mag.*, Dec.)

*Pittosporææ.*

*Pronaya elegans* Hugel. This elegant Swan River shrub has flowered in the Milford Nursery. (*B. M. R.*, No. 200., Nov.)

*Malvææ.*

2014. HIBISCUS  
Wrayæ *Lindl.* Mrs. Wray's ♀ or 10 o P Swan River 1839. C co. Bot. reg. 1840, 69.

A very beautiful green-house shrub, of very easy culture, raised from Swan River seeds sent home by Drummond. It should be planted in the free ground in a conservatory, where it will flower abundantly, "and will continue to produce a succession of bloom throughout the winter and spring." It is named in honour of Mrs. Wray of Oakfield, near Cheltenham, in whose garden it flowered for the first time last summer. (*Bot. Reg.*, Dec.)

3489. ABUTILON striatum  
*Synonyme*: *Sida picta* *Bot. Mag.* 3840.

*Byttneriææ.*

*Thomasia canescens* *Lindl.* A little Swan River shrub, with bright purple flowers, and leaves covered on the under side with whitish hairs. (*B. M. R.*, No. 203., Nov.)

*Geraniææ.*

1932. GERANIUM [1840, 67.  
rubifolium *Lindl.* Bramble-leaved ♀ Δ pr 1 jl P Himalayas 1839. D s.p Bot. reg.

A hardy perennial, of erect habit of growth, but not exceeding 1 ft. high. "It should be planted in light soil, or on rockwork, as it is soon destroyed by the wet in winter." (*Bot. Reg.*, Dec.)

*Balsaminææ.*

*Impatiens candida* *Lindl.* "A noble-looking tender annual from India, growing 6 ft. high, with "large terminal clusters of snow-white flowers, slightly spotted with crimson. (*B. M. R.*, No. 204., Nov.)

*Celastrinææ.*

672. ELÆODENDRON [3835.  
capense *Eck. et Zey.* Cape ♀ □ cu 18 jn G Cape of Good Hope 1828. C co. Bot. mag.

A handsome evergreen tree which requires protection in Scotland, but which would probably endure the climate of London with the protection of a wall. The flowers are small and greenish, and the fruit yellow. It is very different from the plant in common cultivation as *Elæodéndron capense*, which "is nothing else than a narrow-leaved variety of the common bay." (*Bot. Mag.*, Nov.)

*Leguminosææ.*

- INDIGOFERA  
stipularis *Link* large-stipuled ♀ □ or I my Pk S. Africa 1816. S co. Bot. 191.

A very handsome species, which, though introduced so long since as 1816, is not common in collections. The flowers are pink, and they are produced in a dense raceme. The specific name alludes to the large leaf-like stipules. It "is found in elevated rocky situations on the borders of Cafferland, at the eastern limits of the colony;" and it does not require "so great a degree of summer heat as the plants from the neighbourhood of Cape Town." (*Botanist*, Nov.)

*Onagrææ.*

FUCHSIA

*corymbiflora* Ruiz et Pavon cluster-flowered 𐄂 — sp 6 su S. Peru 1840. C. r. m Bot. [reg. 1840, 70.]

This splendid plant was raised by Mr. Standish of the Bagshot Nursery, from seed which he procured, through a friend at Montreal in Canada, from Cusco in Peru; and it is evidently the *Fuchsia corymbiflora* of the *Flora Peruviana*. It was found by Ruiz and Pavon in the woods of Chinchao and Muna, to the north-east of Lima, in shady situations. This country abounds with many beautiful kinds of fuchsia, several of which are not yet introduced, "and remain among the greatest desiderata of florticulture." (*Bot. Reg.*, Dec.)

In a communication which we have received from Mr. Standish, he informs us that "this fuchsia is considerably more hardy than *Fuchsia fulgens*, and indeed quite as hardy as any fuchsia in cultivation." The best way of growing and flowering it, he tells us, is, to prepare a bed in the open garden with light rich soil, in the month of May; and as soon as all appearance of frost is over, which will generally be about the end of that month, to turn the plant out into a bed so prepared, when it will soon begin to grow, and form a massive ball of roots and a handsome head. It may be left to flower in the open ground, or, if desirable, it can afterwards be taken up and planted in a pot, or in the conservatory, without doing it the slightest injury; such is the abundance of fibrous roots that it produces close to the main root. Mr. Standish adds that this plant is a very strong feeder, and can hardly have too much room to grow in, or too great a depth of soil, or too rich a soil. Small flowering plants, he says, may be obtained by taking off cuttings when in a flowering state, and planting them in thumb pots, placing each pot under a bell-glass. They will strike root immediately, and by shifting them into larger-sized pots by degrees, as in growing balsams, they will soon become large plants. The house my plants are now in, he continues, "is kept from 45° to 55° of heat, and the plants are as luxuriant in growth, as if it were now the height of summer. I have a plant of *F. fulgens* in the same house, which is now ripening its wood and becoming deciduous. *F. corymbiflora* is the strongest-feeding plant that ever came under my notice. I think it almost impossible to give it too rich a soil. In the month of January last, I placed a plant of it in a little heat; and, before *F. fulgens* had broken out at all, *F. corymbiflora* had made shoots 18 in. long, which proved to me that this species was more hardy than *F. fulgens*; and I was thereby induced to turn a small plant out into the open ground in the second week of June, the immediate and rapid growth of which I was quite astonished to see. I was also induced to turn out my largest plant of *F. corymbiflora*, which was growing freely, but was showing no symptoms of flowering. This was a tall plant with only one stem; but as soon as it was turned out it began to branch and formed quite a head, and showed flowers in about six weeks after being turned out; while the flowers of the former plant first made their appearance about the middle of September. This plant is now a noble specimen, having broken out with ten strong shoots. The diameter of the plant is 3 ft., and its height 4½ ft.; each shoot having a raceme of flowers. My large plant is now 6 ft. high, but having only a single stem for 4 ft. in height; this makes it anything but a handsome plant. The cause of this plant not branching out is the want of room above, and nourishment at the roots. On reading the description in the *Bot. Reg.* of this plant, taken from the *Flora Peruviana*, it is spoken of as acquiring the height of a man, with a stem little inclined to branch. Now under the culture I recommend, I have no hesitation in stating that it will branch out so as to form quite a bush; and, if planted out

in a rich conservatory border, it will in the course of a few years become a plant at least twice the height above spoken of; and, as to flowering, it appears now to flower at every branch it makes. — *John Standish, Bagshot, Dec. 7, 1840.*”

*Compositæ.*

MONOLOPIA (*Monolopos*, having a single covering; in allusion to the structure of the involucre.)  
 major *Dec.* greater ○ or 3 su Y California 1828. S co Bot. mag. 3839.

A showy free-growing annual, with large bright yellow flowers, commonly known in all the seed-shops as *Helènum Douglássii*. It continues flowering nearly all the summer. “It was introduced from California by Mr. Douglas, and has been extensively distributed by the Horticultural Society.” (*Bot. Mag.*, December.)

2448. CALENDULA  
*Astèrias Fis. et Mey.* star ○ or 1½ o Y North of Europe 1838. S co Bot. gard. 766.

A very beautiful and hardy annual, with a golden yellow flower, and dark green leaves; the stalk is rather slender. It was raised in the Birmingham Botanic Garden, from seeds received from St. Petersburg. It will “flower and ripen seeds in any common garden soil.” It continues in beauty from August to October. (*Bot. Gard.*, December.)

*Ericacæ.*

3614. PERNETTYA [and Bot. gard. 768.  
*angustifolia Lindl.* narrow-leaved ✱ pr 2 jn W Valdivia 1834. C s.p Bot. reg. 1840, 63.,

A pretty little shrub, with white bell-shaped flowers, and small narrow dark green leaves. It is commonly called *Pernètya phillyreifolia* in the nurseries. It is a native of the Falkland Isles, and is very hardy; but, like all other plants of the same genus, it is easily killed by extremes of drought and moisture. It succeeds best with American plants in a peat border; and it is propagated by cuttings, which must be treated like those of heaths. “They should be potted in brown peaty soil, with very little sand in it.” (*Bot. Reg.*, November; and *Bot. Gard.*, December.)

1174. MENZIESIA 9946 *empetrifolia Bot. Gard. 762.*

*Pedalineæ.*

*Martynia fragrans Lindl.* A Mexican half-hardy annual, with very fragrant purple flowers, enlivened by a streak of yellow down the lower lip. (*B. R. M.*, No. 206., November.)

*Convolvulacæ.*

492. CONVOLVULUS 4205 *pentánthus*  
*Synonyme: Jaquemóntia pentántha Benth.* in *Botanist*, t. 197.

□ *C. flóridus L.* This plant has flowered in the Milford Nursery. (*B. M. R.*, No. 199., November.)

*Ipomæa ficifolia Lindl.* A beautiful stove climber, with rich purple flowers, raised in the Victoria Nursery, Bath. (*B. M. R.*, No. 221., December.)

*Solanacæ.*

3565. GRABOWSKIA  
*duplicata Arn.* doubled ☞ □ cu 12 jl W Peru 1838. C. co. Bot. mag. 3841.

A rambling shrub, 12 ft. high, a native of Peru, which requires the heat of a stove to make it produce even a moderate quantity of flowers, which are white, tinged with green or brown; and which are more curious than beautiful. (*Bot. Mag.*, December.)

591. SOLANUM  
*vestitum Benth.* clothed ☞ □ or 6 o W Mexico ... C co. *Botanist*, 192.

A tall shrub, with broad coarse-growing leaves, and large white flowers. It would be worth cultivating, did it not require a stove, for which, on account of “the large size of its foliage, it can be scarcely recommended, except for an extensive collection.” (*Botanist*, November)

*Labiataæ.*

+ *Sálvia Réglæ Cav.* A Mexican half-hardy plant, with bright scarlet flowers. (*B. R. M.*, No. 205., Nov.)

+ *S. prunelloides* Humb. This plant has been raised in the Durdham Down Nursery, near Bristol, from tubers received from Mexico. It is a dwarf plant, not above 8 in. high, with blue flowers; and it is about as hardy as *Verbena Melindres*. (*B. M. R.*, No. 207., Nov.)

*Verbenacæ.*

CHASCO'NUM *Mey.* CHASCONUM. (*Chaskō*, to gape; from the gaping calyx.) [nist, 196.  
cuneifolium *C. Mey.* wedge-shpd-lvd  $\text{♂}$   $\square$  pr 4 ap W C. G. H. 1821. ... s.l.p. Bota-

A half-shrubby plant, with white flowers (which are yellow, tipped with orange in the bud) and very peculiar leaves. It is a native of the Cape. "It requires green-house protection during winter, and should be in sandy loam mixed with a little peat. It requires to be very well drained." (*Botanist*, Dec.)

*Plumbaginæ.*

929. STA'TICE 7511 pectinata *Bot. Reg.* 1840, 65.

*Thymelæ'æ.*

87. PIMELE'A

nana *Graham* dwarf  $\text{♂}$   $\square$  or  $\frac{3}{4}$  ap in W Swan River 1839. C s.p. *Bot. mag.* 3833.

A pretty Australian, about 8 in. high, with a woody stem, which is covered with white hairs. Its leaves are thin and rather long. (*Bot. Mag.*, Nov.)

*Orchidacæ.*

3597. MONACHA'NTHUS 30301 discolor var. *Búshnaní* *Bot. Mag.* 3832.

The lip is fringed. (*Bot. Mag.*, Nov.)

3538. CYRTOCHI'LUM 29798 maculatum var. *ecornutum* *Bot. Mag.* 3836.

A pretty variety, introduced from Mexico in 1840. (*Bot. Mag.*, Nov.)

2547. DENDRO'Bium 28807 moschatum *Bot. Mag.* 3837.

*D. aciculare* Lindl. A curious little East Indian species, with "a single yellowish flower, slightly tinged with pink." (*B. M. R.*, No. 188., Nov.)

*D. gemellum* Lindl. An East Indian species, with "small pale yellowish green flowers, growing in pairs." (*B. M. R.*, No. 192., Nov.)

*D. calcaratum* Lindl. A slender inconspicuous species, with green flowers, growing in pairs. (*B. M. R.*, No. 219., Dec.)

2532. ZYGOPETALUM africanum *Hook.*

*Synonyme*: *Odontoglossum bictonense* Lindl., *Bot. reg.* 1840, 66.

This was supposed by Sir W. J. Hooker to be a native of Sierra Leone, but it proves to be a native of Guatemala. (*Bot. Reg.*, Nov.)

2569. ANGRÆCUM

gladiifolium *Thou.* sword-leaved  $\text{£}$   $\square$  cu 1 f W Isle of Bourbon ... D r.w. [1840, 68.  
*Bot. reg.*

An orchideous plant, with white flowers, of no beauty; found in the Isle of Bourbon, the Mauritius, and Madagascar. (*Bot. Reg.*, Dec.)

*Peristylus Goodyeroides* Lindl. A Ceylon species, with a long spike of pure white flowers. (*B. M. R.*, No. 187., Nov.)

*Liparis spathulata* Lindl. An Indian plant of no beauty, with a long raceme of very small green flowers. (*B. M. R.*, No. 189., Nov.)

*Epidendron viscidum* Lindl. A Mexican plant, nearly allied to *E. ciliare*. (*B. M. R.*, No. 190., Nov.)

*Maxillaria macrophylla* Poepp. Messrs. Loddiges have just flowered a fine variety of this species. (*B. M. R.*, No. 191., Nov.)

*Oncidium microchilum* Bate. A very curious and distinct species from Guatemala. (*B. M. R.*, No. 193., Nov.)

*O. Wentworthianum* Bate. A very beautiful species with yellow flowers, richly stained with crimson. (*B. M. R.*, No. 194., Nov.)

*O. pelicanum* Hort. Monac. Nearly allied to *O. reflexum*. "The name has doubtless been given in allusion to the column, which is not unlike a pelican pecking her breast." (*B. M. R.*, No. 216., Dec.)

*Bolbophyllum flavidum* Lindl. "A pale yellow-flowered orchideous plant, imported from Sierra Leone by Messrs. Loddiges." (*B. M. R.*, No. 195., Nov.)

*B. sordidum* Lindl. A native of Guatemala. "The flowers are very fleshy, of a dull olive brown externally, but highly mottled with purple on the inside." (*B. M. R.*, No. 217., Dec.)

*Roderiguèzia maculàta* Lindl. "A native of Guatemala." It has small flowers, of no beauty. (*B. M. R.*, No. 218., Dec.)

*Eria nutans* Lindl. An East Indian epiphyte, "with a single large nodding terminal white flower." (*B. M. R.*, No. 196., Nov.)

*E. velutina* G. Lodd. "A singular plant, of no beauty, from Sincapore." (*B. M. R.*, No. 209., Nov.)

*E. clavicaulis* Wall. An Indian epiphyte, with pretty white and pink flowers. (*B. M. R.*, No. 220., Dec.)

*Gròbha galeàta* Lindl. "A Brazilian orchideous plant," with dull green flowers stained with purple. (*B. M. R.*, No. 197., Nov.)

*Pholidòta conchòidea* Lindl. A Manilla epiphyte, nearly allied to *P. imbricàta*, but with much larger flowers, "the keels of the lateral sepals" of which "are so deep and concave, as to give the lower side of the flower the appearance of the inside of a bivalved shell." (*B. M. R.*, No. 198., Nov.)

*Polystàchia cèrea* Lindl. A small Mexican species, the flowers of which are in a drooping raceme, and have the colour and texture of old wax. (*B. M. R.*, No. 208., Nov.)

#### *Bromeliàcæ.*

#### PUYA

*heterophylla* Lindl. various-leaved ♀ ☐ cu l my Pk Mexico 1838. D p.1 [1840, 71. Bot. reg.

A very curious plant, with pink flowers arranged in a close oblong spike, and two kinds of leaves. "Those at the base of the plant arise from tough, concave, broad, horny petioles, which overlie each other, forming a kind of bulb, and are extended into narrow, hard, serrated, spiny, brown processes, about 2 in. long. The leaves, on the other hand, which are first formed, are thin, lanceolate, bright green, and more than 18 in. long when full grown, and bear no resemblance to the first." It should be kept in a stove of moderate heat, close to the light, and be allowed abundance of water while it is in a growing state. (*Bot. Reg.*, Dec.)

---

### ART. VII. *On the Culture of Ixias and other Irideæ in the Island of Jersey.* By BERNARD SAUNDERS, Nurseryman there.

AGREEABLY to promise I send you a few hints on the culture of the *Babiana*, *Ixia*, *Sparaxis*, *Tritonia*, &c., which in this island are very successfully grown in the open borders.

In September, or at the latest in October, we begin to prepare our beds by well digging them about a spade and a half deep, burying a stratum of rotten horse-dung at the bottom; about two good barrowfuls will suffice for a bed or border 30 ft. long by 4 ft. wide. The soil, in general, must be a good friable sandy loam, and ought to be well broken in digging; and the beds should be rounded so as to allow the escape of the heavy rains which are here very prevalent in the autumn and winter months. As soon as the ground is thus prepared and regularly raked, begin to plant the roots in rows across the beds, about  $2\frac{1}{2}$  in. deep and 4 in. from each other, and about 8 in. between the rows, covering the bulbs with sand about 1 in. deep previously to covering with mould. After the beds are thus planted, rake and dress them well, and thus the work is completed until towards the spring; observing to keep the ground

free from weeds, and moving or stirring it occasionally with a small fork, which greatly accelerates the growth. The different varieties flower in succession, from the middle of May to the end of June, and large beds of them produce a beautiful effect. I would observe that the distance given above is only meant for the dwarf-growing varieties, such as *Sparáxis tricolor*, and *S. grandiflora purpurea*, and other seedling varieties; as also *Tritonia crocata*, *T. squálida*, *Ixia longiflora*, and *I. longiflora rosea*, which do not exceed from 6 in. to 8 in. in height: the tall and more robust-growing sorts, such as *Ixia viridiflora*, *I. lilacina*, *I. crateroides*, *I. flexuosa*, and others, require at least 6 in. between each root, and from 9 in. to 10 in. from row to row. By thus early planting, they get well established, and will resist a very hard frost; as a proof of which, during the severe frost of 1837 and 1838, when the thermometer was as low as 18° Fahrenheit (see the details in my paper in the *Gardener's Magazine* for 1838, p. 328.), my ixias, &c., were preserved by a covering of about 2 in. of dry sand spread over the beds; scarcely a root was injured.

It is now about twenty years since I commenced their culture on a small scale: finding those succeed, I anxiously sought for more, and have since received several supplies from the Cape of Good Hope, and many fine varieties have been obtained from seed in Guernsey and here, which ripens very freely in the open air. H. Dobree, Esq., jun., of Guernsey, has been very successful in raising several splendid varieties, some of which have been figured in Harrison's *Floricultural Cabinet*. I am also indebted to him for many of those which I have under cultivation, which are as follows:—

|                    |                          |                         |
|--------------------|--------------------------|-------------------------|
| <i>Ixia aúlica</i> | <i>Ix. maculàta</i>      | <i>Tr. lineàta</i>      |
| flexuosa           | <i>Sparáxis tricolor</i> | squálida                |
| capitàta           | grandiflora              | fenestràta              |
| crateròides        | purpurea                 | crocàta                 |
| viridiflora        | sanguínea purpurea       | cristàta                |
| <i>lilacina</i>    | rosea álba               | cóncolor                |
| racemosa           | decora                   | <i>Babiàna coccínea</i> |
| rùbra grandiflora  | formosa                  | kermesina               |
| sulphurea          | Liliàgo                  | longiflora              |
| capitàta           | sanguínea                | plicàta                 |
| lùtea              | tricolor lùtea           | purpurea                |
| rosea              | álba                     | rubescens               |
| arborea            | <i>Tritonia rosea</i>    | rùbra cyànea            |
| cónica             | longiflora               | striàta                 |
| aurántia nìger     | rosea                    | sulphurea               |
| viridis tardiflora | pállida                  | tubulàta                |

Thus may this beautiful tribe of bulbs be cultivated to any extent in these islands. I am still anxious to procure new varieties worth cultivation; and should this meet the eye of any of your numerous readers, who possess sorts different from those



I have named, I shall feel much pleasure in either exchanging or purchasing. I have also under cultivation from thirty to forty varieties of *Gladolus*, some of which are truly beautiful, and on which I will give you an article at some future period. I will also send you a few hints on the cultivation of *ixias*, &c., in the open borders in England, which I have seen successfully practised.

Jersey, Dec. 12. 1840.

ART. VIII. *On the Cultivation of the Pine-apple, as practised in the Kitchen-Garden of the Palace of Versailles.* By M. MASSEY, Director-General of the Gardens of the Crown.

A METHOD of cultivation has been in use for the last twenty years in the kitchen-garden at Versailles, and is now practised throughout the neighbourhood of Paris, which appears to produce quickly and economically the fruit of the pine-apple. This treatment consists, 1st, in the disuse (suppression) of the pot while the plant is growing; 2d, the complete renewal of the roots after the growth of the plant, before fruiting; and, 3d, the exclusive use of peat soil.

1st. *Disuse (suppression) of the Pot.*—The consequence of not using a pot is, that an offset of pine-apple placed, like the melon, on a bed under glass, with the roots at liberty instead of being imprisoned in a pot, vegetates with the same rapidity as in the tropics; that is, it acquires in six months during the fine season, from April to October, all the strength necessary to produce a fine fruit. It is well known that the beauty of the fruit is always in proportion to the rapidity of the growth of the plant, and that consequently a young plant produces a finer fruit than an old plant.

2d. *Renewal of the Roots.*—The roots of the pine-apple are the more active the less bulky they are. It is an advantage, therefore, to replace the roots which have served during the period of growth, by others to serve during the period of fructification. The natural developement of the plant shows its tendency to renew its roots. In proportion as the upper part grows, the lower parts tend to decay, the roots as well as the leaves, and the portion of the stock which bears them. The stock above the roots already developed is everywhere furnished with rudiments of new roots, which lengthen as the old ones begin to decay; but, forced to twist over each other, and to wind among the bases of the leaves which press them strongly against the stock, they can only extend in proportion as the leaves disappear. It is these leaves which are removed in the operation of renewing the roots; a sufficient number are removed to display the portion of the stock where the rudiments of the new roots are already visible, and at the same time all the old roots are removed. Thus left to themselves, the new roots are developed in greater numbers than if a part of the old ones had been preserved.

After the removal of the old roots, the plant is in the same state as the sucker which has just been separated from the parent. It is a true cutting or slip (*bouture*), and it is treated accordingly. Placed in a pot and put on a good bed under glass, sheltered from the air and the light, in a few days the new roots lengthen, and in two months' time the plant has produced a sufficiency of them to be set for fruiting.

3d. *Exclusive Use of Peat Earth.*—The good effects of the suppression of the pots during the growth of the plants, and of the renewal of the roots after their growth before fructification, are singularly increased by the use of peat earth. This earth, it is true, is not so long fit for vegetation as a soil of more consistence, of which a friable mould forms a part; but, with the

method of cultivation in question, this cannot be considered a fault, as the action of the peat earth is only to last six months, that is to say, as long as the plant continues growing, after which period this earth is renewed to last about as long, viz. during the period of fructification.

Peat earth varies in its nature according to the country, but mould may always be had with the same properties, by only taking the surface (3 or 4 in.) of a soil that is not marshy, upon which heath grows in abundance. In the kitchen-garden of the Palace of Versailles, the soil in which the pine-apples grow is the common garden mould, which in this part of the country is pure sand, blackened a little by the manure it has received in the course of long cultivation. The pine plants succeed in this soil, which is in fact only sand mixed with a little mould. They succeed better, however, in a soil of natural peat.

*Shelter, and its Application.* — Four sorts of shelter are necessary for the cultivation of the pine-apple.

1st. A very slight shelter to make the offsets (œilletons) take root, and to preserve them till their growth is attended to.

2d. A similar shelter, but rather higher, to protect these offsets during growth.

3d. A greater degree of shelter to effect the renewal of the roots of these offsets which have already grown, and to preserve them till they are to be set for fruiting.

4th. A still greater degree of shelter and fire heat to force the plant to fructify at will.

1st. *Shelter to make the Offsets take Root*, and to preserve them till the month of April, at which period their growth is attended to.

This shelter is that usually employed by the gardeners of the *marais* (market-gardens), in the cultivation of the melon. It is a simple light, 1 ft. high, the frame of which, without a bottom, is placed on a bed: it is formed of four boards nailed to four uprights of the same height. When this frame is made 12 ft. long, it has two cross bars (traverses) on the upper side to support the glazed panels which are placed upon it. These panels are  $4\frac{1}{2}$  ft. high at bottom, and 4 ft. across.

To exclude the air while the plants are being rooted in this frame, it only requires to fasten moss on the ledge of the frame and on the cross bars, by means of a wire fastened on the upper side by nails put in at intervals, and which are driven in when the moss is placed.

As the offsets separated from the parent live for months without completely withering, though not planted, time may be allowed till a sufficient number have been collected before rooting them. To prevent them from drying before potting them to be finally removed to the frame, they may also be plunged in the tan among the plants of the hothouse, where they will easily root. Tan excites more than mould the emission of the roots of the pine-apple; it stops also the progress of decay in the stock, if it has been injured.

The bed for rooting the offsets should have the high temperature necessary for that purpose. It is covered with tan, in which the very small pots containing the offsets are arranged. Once rooted, a moderate heat in the bed, and mats, are sufficient to protect these offsets during winter. They require no particular care; the chief aim being to preserve them till the month of April, when they are removed to the second frame, for the express purpose of attending to their growth.

2. *Shelter for the Growth of the Offsets.* — The shelter used for the growth of the offsets only differs from the preceding one in respect to its height, which is as high again as the preceding. The frame is 2 ft. high at the back, and  $1\frac{1}{2}$  ft. in the front. The height can be increased at pleasure, by raising the frame, and introducing wisps of straw, as the plants grow and reach the glass.

When, as at the garden of Versailles, a million of plants are to be set, instead of a long simple bed intended to be surrounded with manure (garnie

de réchaufs), several short beds are placed one against the other, so as to form together an immense square bed. The individual beds of this large bed are 6 ft. broad; therefore, when the frames are placed, the space of 2 ft. is left vacant between them for the paths. These paths are filled with manure as high as the frames, to warm the air within, according as the temperature requires, till the fine weather sets in.

About 8 in. of soil is put upon the bed in the frames. This thickness of soil is sufficient. The roots, after having penetrated this soil, may without injury extend into the bed; but, though they grow to the length of several feet, they rather tend to spread horizontally than to extend downwards.

Before unpotting the offsets to plant them in the frames, some of the lower leaves are removed, in order that the rudiments of roots covered by the bases of these leaves may be at liberty to expand. The plants, once established in this manner, require little further care. The roots find sufficient heat in the bed during the summer, and the temperature of the air from the month of April is always increasing. Therefore, in a very short time, all the labour that is required is to give air and a great deal of water and shade. The leaves become red during the great heats, if they are not shaded for two or three hours during the middle of the day. Canvas (a transparent kind of cloth) is the best to break the rays of the sun without intercepting the light. The temperature from the middle of July to the middle of August is sufficiently high to admit of the lights being kept partially open during the night, and to allow of plenty of water being thrown on the heart of the plant, and in the axils of the leaves, where it is preserved as if it were in pots.

3. *Shelter to assist the Operation of the Renewal of the Roots* when the plant is grown, and to preserve it when rooted till it is taken into the fruiting-house.

This shelter should be of sufficient dimensions to admit a person to enter it. Its breadth should be at least 8 ft., to contain the path, the bed, and the flues. It is half-sunk that the air may be preserved rather moist. The summit of the front wall is accordingly on a level with the exterior soil, and the back wall, which is 6 ft. high, rises only 4 ft. above the soil. This back wall, in its lower part, is built in arches, the spaces being filled with plates of metal, by means of which, when it is necessary, dung placed on the outside transmits its heat into the interior. This heat is preferable to that of fire, and is sufficient, when the season is not too severe in winter, to preserve a moderate temperature in the air, suitable to plants that are not intended to be forced, but only to be preserved till their turn comes of being placed in the fruiting-house.

Before potting the plants whose roots are to be renewed, the wounds that have been made in the stock, whether by pulling off the leaves to display the new portion of the stock which is to produce the new roots, or by removing the little offsets which are found, when the leaves are removed, situated at the axil of each, are allowed to dry for several days. In planting the stock, it is plunged two thirds of its depth in the pot, and the mould is to be dry rather than moist, because too much moisture is dangerous when vegetation is in a state of repose. Before plunging the pots in the tan which covers the bed, this bed must have attained a warmth of 30° of Réaumur (100° of Fahr.). This high temperature is necessary to cause a rapid development of the roots. Care must be taken, in the meantime, to stop up the chinks in the lights with moss, and to cover the lights with mats, that neither the exterior air nor the sun may fatigue the plant. At the end of ten or fifteen days the roots are sufficiently developed to allow of a little water being put on the mould of the pots, and at the same time to give a little air and light. The proportion of water for the roots, and the quantity of air and light for the plant, increase as the roots begin to grow. At the end of two months, the plant, abundantly provided with roots, may be set for fruiting.

In order to have ripe fruit throughout the year, the plants are distributed in series, ranking according to size, and these series are set for fruiting succes-

sively, each in its turn, from month to month, from October to July. The series placed in the fruiting-house in October shows fruit in December and ripens it in June; and the last series, which is placed in heat in July, and which shows its fruit in October, does not ripen it till April and May, for fruit ripens very slowly during winter.

As it is only at the end of two months that the plant stripped of its roots has produced new ones in sufficient quantity to be set for fruiting, it is necessary to select, long before the month of October, the plants that are to compose the first series, the fruit of which is to be ready in June. Consequently, as early as the 1st of August, those plants are selected from the frames where they attained their growth, that appear the strongest, to form the first series.

Before being set to fruit, the plants must be kept during the winter at a very moderate temperature. The temperature of the bed may be kept at 15° Réaumur (66° Fahr.); that of the air may be at 15° Réaumur in the day, and 8° Réaumur (50° Fahr.) at night. When the temperature of the air is too high and dry, the heat causes the plants to run to fruit prematurely; when too high and moist, it makes the leaves grow rapidly, when the light of the short days is not sufficient to colour them. For those plants which are to be preserved till their turn arrives of being put into the fruiting-house, the heat of the dung alone placed outside the shelter is more favourable than the heat of the fire.

Watering should be very moderate during the six months of winter. During this time the roots only are to be watered; and to prevent wetting the leaves, and particularly the heart of the plant, which would be liable to perish if the water which may have fallen on it were not removed by a pipe, the watering is effected by means of a funnel, under which there is a horizontal tube formed of several pieces, which carries the water to the most distant plants.

4. *Shelter. Fruiting-house*, where the plants are placed to show fruit.

This hothouse should be large to contain a great deal of air; it ought to be raised above the soil to be very dry; besides, the glass of the sashes must be renewed from time to time, for the action of the light through new glass is as necessary to induce the plant to show fruit, as the action of the dry air and the heat of the fire.

The bed should be new to be very warm, and composed of new dung mixed with leaves to preserve the heat for a long time. It is covered with a bed of tan, in which the pots are plunged. During the two months which elapse before the plant shows its fruit, and also during the time of flowering, the roots should be at a temperature of 30° Réaumur (100° of Fahr.), but not higher; at 40° Réaumur (122° Fahr.) the roots would perish. A thermometer enclosed in a metal tube, and plunged as low as the pots, indicates the temperature.

When the soil round the roots is at the temperature of 30° Réaumur (100° Fahr.), the air may be also at 30° Réaumur during the day, and at 20° Réaumur (77° Fahr.) during the night. This temperature, which in the sunk and damp shelter would make the leaves of the plants grow too much, does not produce the same effect upon the same plants placed in the fruiting-house. The dry heat of this hothouse stops by degrees the growth of the leaves in proportion as the parts of fructification are developed. The offsets are developed also, and sometimes too numerous: therefore, to prevent them absorbing for their own use the sap which was to nourish and swell the fruit, care is taken, after having removed those reserved for multiplication, to prevent the growth of the rest by pulling out the heart with a pair of nippers, long and flat at the point.

Though the plant in the fruiting-house is exposed to a very great heat, it is watered very little during the time it is showing fruit, and then only on the roots. Too much fluidity in the sap, and consequently too much watering, would excite the plant to grow and not to fruit; but from the moment the fruit begins to show itself in the centre of the leaves, till the period when it has attained its full growth, the roots are watered abundantly as well as the plant.

After flowering, to encourage the growth of the fruit, which the dry air of the fruiting-house would cause to ripen prematurely, the plant is replaced in the preceding shelter, where the more humid air and more moderate temperature develop the fruit very slowly, which is indispensable, particularly during winter.

In old hothouses, the trench which contains the manure is open within the house. In the new ones, the opening is on the outside: a horizontal partition, placed 1 ft. from the top of the trench, separates the interior of the hothouse from the interior of the trench, and thus converts the top of this trench into a sort of large case, which, when filled with earth, may be used to fruit plants with their roots free. The advantage of this arrangement is not great for the queen pine and the other small varieties; which produce as good fruit, though the plant is kept in a pot, if this pot, though small, be well furnished with new roots: but the Enville pine, the Providence pine, the handsome pine from Cayenne, and all the other large-fruited varieties which require a great deal of nourishment, do perfectly well with this arrangement. Freed from their pots, and planted in this case when they have formed their new roots, that is, towards the end of November, they continue till summer to grow before fruiting, and acquire so much vigour, that the offsets, when not removed, often produce fruits which may be called fine, by the side of the enormous fruit of the parent.

When too close, the pines shade each other, and increase in height and not in strength. To render them fit to produce fine fruit, they must be kept so far apart at all periods of their growth, that the leaves may extend and present their upper surface to the perpendicular action of the light: and this action is more necessary than that of the sun's rays; for it does not appear that the plants which are deprived of its direct rays, but are otherwise well lighted, are less vigorous than those which receive its rays.

In the kitchen-garden at Versailles, the pines are placed in lines  $1\frac{1}{2}$  ft. apart, and generally 2 ft. between each plant in the line. Therefore, in the shelter where the plants are grown, the frames being 12 ft. long, and rather more than 4 ft. wide, each frame contains 24 plants, placed in 3 lines of 8 plants each. In the hothouses, the trench of each compartment 36 ft. long, and rather more than 5 ft. broad, contains 72 plants, in 4 lines of 18 plants each. The same trench, if the plants belong to the large varieties, contains only 45 plants in 3 lines of 15 plants each.

The first shelter, in which the offsets are rooted when separated from their parent, and the third shelter, where the roots of the plants which have attained their growth are renewed, may each be considered as temporary deposits, where the plants vegetating but little do not require to be kept far apart. The plants may therefore be kept more or less apart, according to the space at disposal.

*Versailles, December, 1840.*

---

ART. IX. *On the Cultivation of the Grape Vine.* From a Paper read to the North Bristol Gardeners' Society, in September, 1840, by Mr. DUNCAN, Author of "Culture of the Melon," &c. Communicated by Mr. DUNCAN.

WITHOUT occupying time with preliminary observations, I will at once proceed to consider the nature of the soil, &c., in vine countries, and in some of those places in our own where it most excels. It may be assumed as a fact, that vines under every circumstance delight in soil of permeable character; in vine districts it is often singularly so. Vines are planted on the ruins of volcanoes, the roots revelling in the scorice of ancient eruptions, and matters accumulated in the lapse of time; on rocky precipices, and the sides of hills; in soils as varied as the sites are, yet suitable, because permeable, and exposed

to solar agency more than we are here. Some of the famed vineyards of the Continent occupy sites similar to these, and have obtained notoriety from circumstances of a like kind. Hence it is evident that much of the success attending vine culture in Britain depends upon a judicious choice of site and soil. The finest vines in the West of England grow on the sides of hills, from south-east to south-west, in soil of a strong loamy character, invariably lying over rocks, the mountain limestone and old red sandstone formations here, and the primitive rocks around Bath; and an instance once occurred in my experience, of a vine flourishing in a bed of loose rubble on the side of a hill declining about 10 degrees. Thus it appears from these cases, that the stratum, or bed, and the declination of the situation are important auxiliaries in the successful growth of vines, inasmuch as both are favourable to the admission of solar heat and escape of superfluous water, which, in connexion with others, particularly determine the welfare of most grapes grown in England. Samples of mould sent here from Oporto, and experiments instituted in past years, convince of the truth of these remarks, and the experience of practical men adds testimony to the same views. In making vine borders it is therefore exceedingly important to have them well drained, and at a considerable declination. The drains here consist of a continuous mass of stonework, the spaces between being filled with rubble, forming a complete and substantial groundwork for future operations, when it will be productive of the first importance. The border is composed as follows, namely, one part turfy sandy loam, one part frame, or cow dung reduced into simple mould, one part road-scrapings from great thoroughfares, and one part bones, carcasses of animals, and similar matters, stones, and rubbish; these, except the animal portion, should be completely amalgamated into a homogeneous mass previously to using. The extent and depth of soil necessary for a vine border may be known by the lie of the ground. If a level or nearly level site, less depth, but if considerably sloping, greater; the former at  $2\frac{1}{2}$  ft., and the latter at 3 ft. deep, and in both cases extending in proportion to the superficial admeasurement of the roof of the house.

The next thing to be considered is planting vines, which is undoubtedly best effected in the autumn of the year, or immediately after making wood in the spring, in June. If a vine is planted in June, it will form a fine cane in the same year; but, if in September, it will become established for surer and more permanent results in succeeding years. They should in each case be laid a couple of inches deeper in the soil than they were before; and, if in September, the roots must be carefully loosened from their matted condition, and placed in a lateral direction in the border, and at most 3 or 4 inches under the soil. Muscats should be planted within the house, or else in soil exclusively prepared for them, of a drier nature, and in a warmer place.

With respect to the future management, there are several subjects for consideration; and however well vines may grow, and appear equal to produce a crop of grapes, it is wrong to let them do so till they have attained a sufficient age: the importance of a well-established plant is greater than any consideration of the former kind, unless destined for it originally. If a vine is capable of bearing, it will appear so by the solidness and vigour of the wood, and by the dimensions of its stem; and it is pretty evident that, in general, it will not be in this condition under three or four years time. To obtain only a moderate crop of grapes, a vine should girt  $2\frac{1}{2}$  in. above the ground, and, if less than this, the result will be otherwise than satisfactory.

Pruning vines is a most important process. Various systems or modes of pruning are adopted, but it appears clear that a successional one is the best; by which I mean a system which includes the fine buds situated at the extremities of young shoots. Under usual management, it is impossible to do so without endangering the development of the lower ones, or inducing exhaustion by the quantity retained; for, if the force of excitement be confined to a single rod under equal circumstances, the spaces between the laterals will be insufficient to admit a proper quantity of light, &c. I have hitherto considered it best to prune at the fall of the leaf, whether it be in October or

December. It is essential to good management, and the welfare of the tree, to afford a long rest, in order that the wounded parts may become healed, and the exhausted energies of the plant refreshed. The vines under my care have been cut to the first convenient bud within the house for two seasons following the planting, and the shoots from them have proceeded unstopped. In the third year, these shoots were cut to three eyes or buds each; the two lower ones to form permanent branches in the future arrangement of the tree, and the other, or terminal one, to become a fruiting cane in the year following. It will be necessary now, being the third year, to stop the leader some little distance beyond, when it is intended to be left for bearing, which, in general, will be 18 or 20 feet. In the strong-growing kinds, every third bud is displaced, and in the short-jointed ones, Sweetwater for instance, every other two; the remainder will then be situated at proper distances, and in alternate order, and the fine buds at the extremities will be preserved: the juices, being diverted from the displaced buds, will cause a surer development of the retained ones, which, in conjunction with a greater portion of solar light, will induce a vigorous and fruitful habit. The shoots at the base of the terminal leader (intended to become permanent branches) are shortened to a few eyes each, and the shoots proceeding from them are shortened at half the length of the original leader. This stopping is intended to divert the current of sap, and cause it to flow into the first leader, now bearing fruit. The same reason may be assigned for stopping the bearing shoot itself and laterals at one joint beyond the fruit; for if the terminal be permitted to proceed unstopped at this early state of bearing, the laterals at the lower part of the stem will be deprived of their proper quantity of nourishment, in consequence of the rapid flow of sap towards the extremity, situated, as it is, in a warmer medium, and in a higher position.

In the future pruning, the stems are cut to two buds each, and, when evolved, the weaker of the two, or the one having the smaller cluster, is removed. Muscats are sometimes cut to the third or fourth bud, but the close system of pruning, wherein the spurs are removed entirely, is not productive of the desired results in continued succession, because it is not in accordance with the known principles of vegetable physiology. The original shoot in the second year of bearing is permitted to occupy the top part of the house, and one of those at its side encouraged to become a fruiting cane in the following or succeeding years; while the other, at the opposite side, is retained in store until the original shoot is intended to be removed, forming a system extending over a series of years in succession, calculated to obtain fine and abundant grapes, and a vigorous and healthy tree.

I will now proceed to explain some particulars in connexion with the climate in vine-houses, and the casualties, &c., experienced everywhere, more or less, where vines are cultivated. The vine is a plant that requires to be managed according to fixed principles. A slight variation or diversion from determined rule, or a mistimed act of unquestionable utility, is often productive of serious consequences. Hence the propriety of simulating those fundamental laws of nature regulating the development of vegetable life. The genial showers and gradual increasing temperature of spring are no less beneficial to general vegetation, than genial when imitated in a house of vines. And when external circumstances concur with operations of forcing in houses, they are productive of the most important advantages to vegetables under excitement: consequently, it is necessary to contrive that the difference of the temperature, internally and externally, shall be as little as possible, by covering the roots and bole, not so much to supply heat, as to prevent the escape of heat existing in the soil, and injury from excessive rains or frost. At the development of the buds the temperature should be low, a perfect resemblance to circumstances determining a similar act out of doors, gradually increasing to 50°. A regular and abundant supply of moisture should be afforded, both by syringing and sprinkling, for if the temperature should exceed this amount, or water be sparingly applied, many buds situated at the hinder parts

of the vine would hardly break at all, owing to the current of sap setting in strongly to those buds more favourably situated. In the interval preceding inflorescence, a considerable increase of heat may be afforded, and abundance of air admitted; both are important in strengthening the young shoots and embryo clusters of fruit, and prevent those discouraging symptoms of weakness evinced by the decay of the clusters. During inflorescence, the temperature should be never less than  $70^{\circ}$  nor exceed  $80^{\circ}$  Fahrenheit. Grapes set best in a sultry atmosphere considerably charged with moisture, supplied by insensible evaporation from pans on the flues, and by sprinklings, &c. If the wind should be cold, or the weather unfavourable, I would advise artificial impregnation, especially in the tender kinds, such as Muscats, Damascus, Sweetwaters, &c. This is best effected by introducing a cluster of some other kind, that can be spared, among the florets of the one intended to be impregnated. Such an act will become important in the future distention of the berries; for it will be seen that the clusters are impregnated, and the berries composing the cluster will be finer and more complete than others not impregnated. After this, syringing should be resumed, and continued till the berries have done growing; but it should be tenderly effected, and with tepid water. During the period included from impregnation to the complete development of the berries, it is most important to close early, while yet the sun is shining strongly, say at 2 or 3 o'clock in the afternoon; for a high temperature, in conjunction with the vapour generated from syringing, &c., will produce results most favourable to the progress of the young fruit, the same as Nature in her happy moods delights in. The gentle showers in a summer afternoon, under circumstances of a like kind, produce consequences precisely similar, but greater, because more general; and so it is in houses where the imitation is complete, and adopted to a right extent. When grapes begin to colour, it is necessary, — yea, as important, to obtain a dry atmosphere, as it was previously a moist one, because the change effected in grapes while ripening is produced under the full influence of light, heat, and dryness: and it is well known that grapes grown in dry heat, or properly managed houses, acquire flavour superior to those grown in plant-houses, or in other places where they cannot be taken care of. If the roots of vines be situated within the house, or a dry season should occur, a plentiful supply of water should be given; for though the vine flourishes in soil of open texture, and situations of a dry nature, yet it is essential to have water, under all circumstances, sufficient to dissolve and supply the food necessary for its subsistence; this, in some cases, is considerable. I have known as many as 200 gallons given to a vine at two waterings while the grapes were small, and after stoning, previously to turning colour at the last stage of development; and it was productive of the best result. Hence it is important to have the use of a good pond of water. But, at the same time, it must be borne in mind, that good drainage, or an equivalent, is necessary, or else the results following will be otherwise than satisfactory.

After the berries are stoned, the temperature should be maintained at least at  $70^{\circ}$ ; under the influence of light, and an advanced season, it may be more, but the maximum, under all ordinary occurrences, should not exceed  $95^{\circ}$ . This kind of management is necessary to the termination of the business, even till the wood is perfectly ripe; for it is exceedingly more important to effect this when the sun is in the ascendant, than in the autumn when it is not so powerful. I must not, however, be misunderstood. I do not mean that it is not requisite to have fire heat in autumn if circumstances require it, such as unripe wood, &c., but that it is more philosophical while the plant is still growing, and there is more certainty of its being effected properly than at any other period of the process.

Another point of consideration is colouring the berries: this depends upon several contingent and important circumstances, the substantial goodness of the border, drainage, aspect, and declination being the chief. Whatever affects the roots or indeed any part of a vine most assuredly induces corresponding results in the fruit, and want of colour may be cited as an instance.



There are other causes, distinctly separate from the preceding, that prevent grapes assuming a proper colour, namely, excessive cropping or superabundant wood, and both inducing general debility; a decrease of temperature before or while ripening, or extremes at day and night; and want of sufficient air, light, and space: the former may be avoided by care in the original plan and construction of the border, &c., and the latter by apportioning the quantity of fruit and extent of wood to the real vigour of the tree, by a continuance of fire heat, when necessary, till the temperature in general equals the minimum amount required at night (this will seldom occur till the latter end of June or beginning of July). Admit air at every reasonable opportunity, and invariably sooner in the morning than under ordinary management; and, lastly, let every branch occupy sufficient space, the extremities of the leaves be everywhere separate from each other, and a proper interval between the spurs.

In corroboration of a part of the previous statement, I will mention an instance which occurred here for several successive years. In forcing an old house of vines, we admit a continual current of air at the end where the fire enters; in fact, it is necessary to maintain the temperature at both ends nearly alike. At this end of the house, invariably, until the present year, have been the most abundant, finest, and best-coloured grapes: but in the present year the case has been materially different, in consequence of Dr. Arnott's stove being situated at the other end, which avoided the necessity of admitting air in the usual place and to the usual extent. The result of this experiment was satisfactory, inasmuch as the difference in the quality of the grapes was inappreciable, and totally dissimilar to the experience of former years. It is necessary also, in admitting air, to do so with some regard to the amount of difference between it and the temperature of the house. Some contrivance should be formed to make the difference as small as possible, by making it pass through a warmer medium, sheds, &c., or apertures at some convenient distances from the foliage, or through wire or other network. The best-coloured grapes that I have seen in the present year are fully exposed to light, and the air is admitted through a doorway of an adjoining house, and escapes at the light beyond where the vine is situated. Good grape-growers seldom allow a direct current of air, except in extremely warm weather, and even then never through a doorway, unless it be situated at the hinder section of the house, because the temperature there is generally higher than in front; and to admit air in front, unless in favourable weather, would cause a difference in the two places very considerable and of some importance.

In conclusion, I will notice the cause of the shriveling or decay of the peduncular attachment of grapes, and cracking of the berries just previously to turning colour. Both arise, or may be induced, by one or more of several unfavourable circumstances happening in certain periods of a vine's development, and from some important particulars deficient where the vine is planted. Whatever hinders the full access of solar heat and light, or determines the temperature of the soil much less than the temperature of the air, weakens the principle of vitality. Excessive cropping and superfluous wood will do the same, and is the more inexcusable as it can easily be avoided, while some other equally decisive, though not so general, causes, induce the same almost unaccountably; for instance, a low temperature after a high one, while the grapes are ripening, often occurring in summer forcing, from the disuse of fires prior to the nights becoming warm. Excess of moisture prevailing, unaccompanied with a proper degree of heat, will be exceedingly injurious to vegetable susceptibility: if a little antecedent to this, it will be evinced by a disruption of the cuticle of the berry at the time, shriveling, and general decay of detached portions, and the whole of some kinds. During the period of ripening, commencing from the first appearance of turning colour, the atmosphere should be more than ever pure, and at that standard of dryness and warmth necessary for the perfect development of the fruit. Further, if the wood of vines has not been ripened well in the year preceding, or, in other words, if the elaboration of juices has been incomplete, the quantity of secreted matters will be less, the buds less stored, and the wood immature, most assuredly unequal to

the task of ripening, however well other circumstances may accord; for the very principle of life itself seems weakened by the effort made, and a repetition of similar management to this injures more vines than is generally imagined. Some kinds of grapes being more hardy than others, are less liable to misfortune than others; Muscadine and Esperione, for instance. Some are liable in an extreme degree, and become spoiled from circumstances that would not affect other kinds: such are Frontignans, Muscats, Syrian, &c. A few are happily situated at a medium, remarkable for their goodness and adaptation to general use, though not partaking of the extreme qualities famous to the Muscats and Frontignans: these are Black Hamburg, Dutch black Hamburg (said to be a grape of first quality), West's St. Peter's, Tripoli, Damascus, &c. One other I will mention, a Frontignan, a grape of the very best character, something resembling the Dutch Sweetwater in appearance; when ripe, of a beautiful amber hue, and the rich muskiness of the Frontignans is pre-eminent here. The clusters are closely set, and moderately large, the berries being considerably larger than any other of the Frontignan family. It is not known under a recognised nomenclature here, unless it be Chasselas Musqué, or is probably a seedling of former times undescribed. It is, as far as my knowledge extends, confined to this place. The entire stock has been presented to the proprietors of the Durdham Down Nursery, of whom plants may be had in the following spring. I had intended to have entered into some other particulars, but this paper is already sufficiently long.

*Near Bristol, October, 1840.*

---

ART. X. *On the Destruction of Mice in Cucumber Frames.*

By J. WIGHTON.

IN the spring of the present year, 1840, the cucumber plants under my care were much injured by having their shoots and fruit cut off. At first, I thought slugs did the injury, but I soon found something more mischievous, for the shoots were cut through, as if eaten by mice. I destroyed several mice, and amongst them two of the shrew kind, suspecting the latter to have done the injury, but the mischief done to the plants was as great as ever. After several fruitless attempts to discover my pests, at last I caught a mouse, quite of a different kind from those previously mentioned; it was the short-tailed field mouse. I found he and his neighbours were the real enemies I sought for, and thought that now my troubles would soon be at an end, as I could easily destroy these little vermin. I soon found, however, that was not so easy a task as I thought; the plants still were destroyed, and all my endeavours to poison or entrap my enemies were fruitless, owing to their not eating food greedily like common mice. Seeing this, and knowing their haunts to be in woods and fields, I suspected their principal food to be vegetables and roots: in this I was not mistaken; for when I put some roots of the *Bunium flexuosum*, or earth nut, amongst the cucumber plants, they were soon eaten up. After that, I found no trouble in destroying them with traps baited with earth nuts.

Buffon describes the mouse I have noticed, and says "it is very plentiful in some parts of France, where it often damages corn by cutting through the stems to get at the ears, by bringing them down. I consider that when they cut off my cucumber

plants it was in search of moisture, for when I placed water in the beds the injury done was less. The difficulty I had to contend with was, the finding what food the mice would eat. I have taken notice of it, for it may be of use to others that may have the bad luck to get a visit from such vermin; for it is really vexing to have cucumbers destroyed in such a manner, especially in the month of March.

*Cossey Hall Gardens, Nov. 24. 1840.*

---

ART. XI. *On the Culture of the Early Horn Carrot.* By J. SEYMOUR, Kitchen-Gardener to the Countess of Bridgewater at Ashridge.

ACCORDING to promise, I send you a few remarks on the Early Horn Carrot, as to weight, size, productiveness, and clearness of the roots, &c.

By referring to my diary, I find my crop of this year was sown on the 30th of March, in rows 1 ft. apart, and the alleys 2 ft. wide; and that they were taken up on the 2d of November. I let these remain longer in the ground than I usually do, to see the difference of the roots as respecting the attacks of the wireworms.

I have grown them upon the same piece of ground this year that I have used since 1837; and as to flavour, appearance, &c., you can decide by the roots that I have sent you. I have not selected the largest roots, considering that they would be large enough for the purpose intended. Amongst the roots you will find one eaten by vermin, to about 3 in. of the top; there was in one bed about one square yard eaten in the same way. I thought it had been perhaps a grass mouse or shrew; but not being able to find any holes near the spot, I am quite at a loss to know what animal it can have been. In all the roots that were eaten, they had been begun at the very extremity of the root, and worked upwards to within two or three inches of the top. The teeth-marks resemble those of a mouse. There were several roots eaten some distance off close by the surface of the ground; these I considered to be the grass mouse, as there were two or three caught close by.

The piece of ground measured was 1,290 square feet, and it produced 2,550 lb. of roots, or 1 ton 2 cwt. 3 qrs. 2 lbs., making a produce of 38 tons 8 cwt. 11 lb. per acre.

One root (sent) was 10 in. in length, 10 in. in circumference, and weighed 1 lb. 6 oz.; 2d root was 16 in. in length, 10 in. in circumference, and weighed 1½ lb.; 3d, 14½ in. in length, 9¾ in. in circumference, and weighed 1 lb. 5 oz.; 4th, 1 ft. long, 10¾ in. in circumference, and weighed 1½ lb. There was a very small taproot, from 3 in. to 6 in. in length, attached to these roots; they were washed, and the tops cut quite close to the root.

I have grown the Altringham long orange, Surrey long, and the New white Altringham, but I prefer the Early Horn for a garden, much before the other sorts, as it grows to a better size for the table, and in my opinion is of a much better flavour; and, as to keeping, it keeps more firm with me than the larger sorts.

I sent up to London good old carrots in May and June for the family. (See my method of keeping, &c., *Gardener's Magazine* for 1840, p. 207.)

I would strongly recommend the New white Altringham for field culture, as I find there is greater weight on the same space of ground than of any other carrot I know. One root of the white, 1 ft. 3 in. in length,  $10\frac{3}{4}$  in. in circumference, weighed 2 lb. 2 oz. One root of the Altringham, 1 ft. 4 in. long, 9 in. in circumference, weighed 1 lb. 6 oz. Two roots ditto, 3 ft. 5 in. in length, 10 in. in circumference, weighed 15 oz. (together). One root of Surrey long, 1 ft. 2 in. in length, 10 in. in circumference, and weighed 1 lb. 14 oz.

These roots are about a medium size, the tops off and washed. It must be understood that this is not a carrot soil about here, it being very cold, and containing a great many flints. The subsoil is a very strong red clay, and sometimes chalk is found within a few inches of the surface. Let me add, that where my carrots grew was made soil, and of a good depth, and that it lies very low. I hope that this may lead to larger trials of the Early Horn, and I hope to see the results of the trials mentioned in your Magazine.

*Frithsden Gardens, Ashridge, Nov. 16. 1840.*

---

## REVIEWS.

ART. I. *Die Coniferen nach Lambert, Loudon und anderen.* Frey bearbeitet von Franz Antoine. The Coniferae after Lambert, Loudon, and others. Newly composed by F. Antoine, with plates. No. I., pp. 20, folio, 4 plates. Vienna, 1840. Price 4s. plain, and 6s. coloured. To be completed in 8 or 9 Numbers.

THE author has been induced to undertake this work from the important rank which the Coniferae hold in nature, in our northern hemisphere, and also in forest culture, and in the planting of parks and pleasure-grounds. As the Coniferae have hitherto been described only in very expensive works, his object is to produce a book which shall be within the reach of every cultivator; and, for this purpose, he has had recourse to all the recent works, and more especially to those mentioned in his titlepage; and he has made the drawings, and lithographed them himself, by which means he can offer his book at the low price above-named.

The work commences with Sect. 1. *Leaves in Pairs*; and the species he describes and figures in his first No. are: 1. *Pinus sinensis* Lamb., Arb. Brit. iv. p. 2264.; 2. *P. brütia* Ten., A. B. iv. p. 2234.; 3. *P. halepensis* Ait., A. B. iv. p. 2231.; 4. *P. pyrenæica* Lap., A. B. iv. p. 2209.; 5. *P. Laricio* Poir, A. B. iv. p. 2200.; 6. *P. resinosa* Soland., A. B. iv. p. 2210.; 7. *P. Banksiana* Lamb., A. B. iv. p. 2190.; 8. *P. sylvêstris* Lin., A. B. iv. p. 2153.; 9. *P. uncinata* Ramond, A. B. iv. p. 2187.; 10. *P. pumilio* Hænke, A. B.

v. p. 2186.; 11. *P. variabilis* Lamb., A. B. iv. p. 2243.; 12. *P. mitis* Mich. A. B. iv. p. 2195.; 13. *P. inops* Ait., A. B. iv. p. 2192.; 14. *P. pungens* Mich., A. B. iv. p. 2197.; 15. *P. Pinaster* Ait., A. B. iv. p. 2213.; and 16. *P. Pinea* Lin., A. B. iv. p. 2224.

In a letter, which accompanied the copy of the work kindly presented to us by M. Antoine, he says, "A journey which I made some time ago to the Snow Mountain and its environs in Styria, near Vienna, confirms my opinion, that the three so-called species, *Pinus Laricio* Poir., *P. austriaca* Hænke, *P. Pallasiana* Lamb., are only varieties, differing from *P. Laricio*, as the type, according to soil and situation. For instance, you can find some individuals with the habit exactly like that of *P. Pinea*, if the tree grows on rocks; but if the tree grows on a loose rich soil, it assumes a pyramidal shape, like *P. Ströbus*, with long leaves. Dr. Unger of the Johanneum at Gratz, and Dr. Grisebach of Genoa, are of the same opinion with me respecting *P. Laricio*. *P. pumilio* I found on the Snow Mountain in Styria in great abundance. On the lower region, where it is mixed with *Abies excelsa*, this pine has the original shape of *P. pumilio* Hænke: higher up the whole plant is diminished to the height of only 2 or 3 feet; its leaves are very short, and the cones very small. This, I think, is your *P. carpatica*, or *P. pumilio nana*. On the highest region, *P. pumilio* produces no cones, but sometimes abundance of male flowers, the plant growing not higher than 8 or 10 inches, and the branches lying along the surface of the soil or rocks, and not more than 3 or 4 feet in length." This corresponds with what Dr. Martius told us, when we were at Munich, in 1828, respecting *P. pumilio* on the highest ground in Bavaria, and which Dr. Martius was fully convinced was only a variety of *P. sylvestris*.

The titlepage to this work is a fanciful composition, which may rank in point of taste with that of Bateman's *Orchidaceæ*; and the plates, which are in the first number limited to the cones and leaves, seeds, scales, and male blossoms, are in general faithful copies of the originals in Lambert. That which is least like nature is the cone of *P. Laricio* var. *Pallasiana*, in plate 1. This cone is readily known from that of all the other species or varieties in the section to which it belongs, by the tips of the scales being flattened. The bud of *P. Laricio* and its varieties, however, is a sure mark of distinction, as it differs widely from that of all other pines.

M. Antoine deserves great credit for his endeavours to spread a knowledge of this interesting and important order of trees, and we trust he will be patronised by arboriculturists in this country as well as in Germany.

---

ART. II. *The Eastern Arboretum, or Rural Register of all the remarkable Trees, Seats, Gardens, &c., in the County of Norfolk.*  
By James Grigor. Illustrated by drawings of trees, etched on copper. Nos. V., VI., and VII. 8vo. London and Norwich. 1s. each Number.

THE preceding numbers of this interesting work were examined in p. 601. and 665. of our volume for the past year, and we now return to it with much pleasure, because Mr. Grigor is a man after our own heart. Blickling Park was commenced in Number iv., and the account of it extends to Number v. The park and pleasure-grounds comprise about 1000 acres, finely wooded with pines, firs, cedars, and planes. An Eastern plane has a trunk 9 ft. 9 in. in circumference, with a head covering a space 78 yards in circumference. A pinaster is 65 ft. high, with a trunk 10½ ft. in circumference. A Scotch pine, 70 ft. high, has a trunk 14 ft. in circumference at 1 ft. from the ground; it is supposed to be the largest tree of this species in Norfolk. In the kitchen-garden is an espalier tree of the Harbord pippin, which covers a space 28 yards in length, and bears plentifully every year. An oak is

70 ft. high, with a smooth trunk at 32 ft., and it contains 6 loads of timber. Another has a clear stem of 40 ft., and contains 7 loads of timber. The sweet chestnut trees are of noble dimensions.

“ On the north side of the lake, close to the edge of the water, are the remains of an oak, hollow and open on all sides, the trunk of which measures the unusual circumference of 24 ft. This is apparently the oldest tree, retaining any trace of life, upon the estate.

“ Upon the whole, we consider Bickling one of the finest seats in the county. It possesses many natural advantages, which have been turned to good account both by the present and former possessors. Its beauties are carefully preserved under a pure and enthusiastic taste; and we repeat that, looking upon it from a certain point on the pleasure-ground, nothing can possibly surpass the lovely and diversified landscape which it exhibits. It is a place which judges of gardening describe as *well kept*. There is nothing in this respect to offend even the most critical; and whilst every thing new, calculated to adorn and beautify, finds a place here, the objects which already grace this seat — the venerable chiefs of the field — are cared for and watched over with great interest.”

*Our Trees.* No. 4.—Under this head some noble cedars of Lebanon are described, and an engraving is given of a magnificent specimen at Stratton Strawless.

*Wolterton Park; the Seat of the Earl of Orford.*—The house was reckoned in Walpole's time one of the best in England, and Mr. Grigor describes the park and pleasure-grounds as of “varied excellence.” An engraving is given of a magnificent beech with its branches feathering to the ground. It is 65 ft. high, with a trunk 16 ft. in girth.

“ The present noble proprietor, whose taste for trees is well known, has distinguished this place above many others, by forming in it collections of trees and shrubs belonging to the genera *Pinus*, *Abies*, *Cupressus*, *Schubertia*, *Araucaria*, *Erica*, *Cratægus*, and *Ilex*. The collection in the pinetum is very complete, including specimens of the *Deodara* pine 9 ft. in height. The *Araucaria excelsa*, or Brazilian pine, as it is called here, rises to the height of 9 ft. 9 in., and bears the rigour of winter with a very slight protection. Such arboretums are of endless interest, displaying how far trees of foreign countries are adapted to this climate; their comparative growth, outline, and specific character; their adaptation, consequently, to particular localities,—in short, their whole history with regard to the district where they are situated. Without such a collection, grouped under proper divisions, with the age, size, and height each individual plant attains to in its native place, its particular habitation therein, and every other circumstance of interest connected with it, trees lose half their charms, and form but an unmeaning profusion of beautiful forms. This arboretum, then, may be looked forward to with interest. Twenty years hence, the trees will have become perfect, and their character and worth ascertained.”

*Barningham Park; J. T. Mott, Esq.*—A beautiful and ancient seat, embellished with fine timber trees. It is our duty as well as our delight, says Mr. Grigor, “to make honourable mention of the very elegant manner in which this place is kept. Its order and neatness are observable in every department, and in none more conspicuously than in the scenes of the garden and pleasure-grounds.”

“ The whole appearance of this place reminds us of the fruit and culinary gardens of the Scotch nobility; for it is a well-known fact, that, whilst the English excel in the pleasure-ground or ornamental department, their northern neighbours have a superior taste in managing the gardens where the more profitable and useful products are reared. This, then, in our opinion, may be considered a model-garden, where the youthful who are anxious to learn will find much to admire and copy.”

An etching is given of a very elegant lime tree, and due praise is given to the gardener, Mr. Cockburn.

*Felbrigg Park*; *W. H. Windham, Esq.* — “A magnificent place, surrounded by some of the fairest fields in England, and made dark and solemn in some instances by umbrageous timber trees.” An etching is given of a very magnificent walnut. “Such parks are England’s badge.” In the kitchen-garden are a Breda apricot, and a Genoa fig, both of a hundred years’ standing. The apricot covers a space of 612 square feet, and bears from 60 to 90 dozens of fruit yearly. Mr. Robins, the gardener, is a celebrated grower of pine-apples. It was at Felbrigg that Mr. Kent, author of *Hints to Gentlemen of Landed Property*, and the founder of an office for the valuation and management of landed property, in Craig’s Court, Charing Cross, London, began his career as land-steward.

*Cromer Hall*; *H. Baring, Esq.* — “An elegant mansion, situated upon an eminence, almost on the verge of the British ocean, environed by a vegetable throng of such beauty and vigour, that we are almost apt to forget that the sea breezes have any prejudicial effect upon trees and shrubs.” (p. 130.) An ash, 75 ft. high, girths 10 ft. at the ground; a Scotch pine has a trunk 7 ft. in circumference; a sweet chestnut 9 ft.; and an oak 13 ft. 6 in.

*Gunton Park*; *Lord Suffield.* — “One of the older retreats in the county, surrounded by wide-spreading plantations and extensive parks.” An etching is given of a remarkably fine yew: at 1 ft. from the ground it girths 6 ft. 1 in., and at 5 ft. it girths 6 ft. 8 in.; it is 35 ft. high, and covers a circle of 45 yards round.

There is a lofty avenue of beech trees, and the varieties of the English oak are exceedingly numerous; some of them being of a dark green colour, with leaves deeply lobed and in bunches [doubtless *Quercus pedunculata*], whilst others are of a lighter colour and very slightly notched [doubtless *Q. sessiliflora*]. Many of the beeches have stems 40 ft. in length and 13 ft. in circumference at the ground; but the most celebrated tree is the “Great Oak,” the “King of Thorpe,” to be hereafter mentioned.

*Horsford Hall*; *Mrs. Day.* — “In ancient times a place of great note.” A Scotch pine here is 65 ft. high, with a trunk 9 ft. in circumference; an oak covers a circle 85 yards round, and an English elm is 70 ft. high, with a trunk 12 ft. in circumference.

*Felthorpe Park*; *J. Geldart, Esq.* — A place rich in trees, and formed within the last 17 years out of some of the poorest land in Norfolk, and affording an admirable example to possessors of “poor and miserable spots.”

“In visiting such a place, the following reflections naturally suggest themselves to us, namely, — That the nature of trees is beginning to be understood; and, consequently, that a great proportion of the waste land in our country may be converted either into fruitful fields, or made to assume the appearance of fertility. So lately as forty years ago the oak tree was assigned to rich sheltered valleys, and there only; and if any one had been bold enough in those times to have planted it elsewhere, he would have been subjected to the ridicule of his neighbours. We trust the time is at hand when, so far as regards the hardy trees of Britain, there will be less distinction made as to soil or situation; not that we do not believe that certain soils are favourable to the growth of particular species of trees, but because the fancied partiality of *all* trees to certain soils has deterred many from planting altogether. It is now a well-known fact, that if sheltered when young, an oak will grow almost anywhere, and that a sycamore will grow on any land without shelter.

“Generally speaking, however, a seat such as this is, and on such soil, so completely wooded and so elegant in many of its traits, is only to be realised by considerable care and expense.”

*Booton Hall*; *S. Bircham, Esq.* — “A wide-spread park graced by some noble trees, which are chiefly of the oak kind.” These oak trees “display an endless variety of form and hue; some of them presenting a pendulous character, others of a fastigate outline; whilst as to leaves, some are lanceolate, some entire, and others again deeply lobed and of an evergreen colour. In fact,

there are no bounds to the varieties that may be discovered in this plantation, and we have no doubt that, when the foliage is about to fall, the contrasts will be still more apparent."

*Our Trees*, No. 5., is a chapter on the yew tree. In former times, when yew hedges were very much planted, it was of great consequence to select plants with leaves of the same shade of green, and for this purpose varieties with a fine deep shining green foliage are directed by the Dutch writers to be propagated by cuttings.

"When this plan is adopted," Mr. Grigor observes, "shoots of nine inches in length should be selected either in the month of April or August, taking care to cut them immediately below the last year's growth, so that a small portion of the wood which is two years old may adhere to each. If this be attended to they will strike root more readily. The lower leaves should be trimmed off at bottom, and the slips planted in a sheltered and shady border of light sandy soil. In the course of two years they will be sufficiently rooted to be removed into nursery lines, where they may remain for two years more previous to their final transplantation. If the plants are to be raised from seeds, which is the process most generally adopted, the berries should be gathered in October and immediately sown in very loose friable soil, in such land as is likely to retain these qualities for two years or more, for the plants will not all appear till the second spring; and if the seeds be placed in firm clayey soil, the likelihood is that it becomes so hardened by the weather that no vegetating power can break through it, and, consequently, a very meagre crop is the result."

*Haverland Park; E. Fellowes, Esq., M.P.*—A splendid mansion in the Italian style of architecture is now being erected here, and the grounds "are to be remodelled by a landscape-gardener of some note of the present day—at least, so far as this county is concerned." The park is rich in old trees, "some of them most wonderful vegetable structures, especially *Ulmus montana glabra*: but the finest tree on the estate is an alder, of which an etching is given: it is 62 ft. high, with a trunk at one foot from the ground, 11 ft. 7 in. in circumference.

"It is an upright well-proportioned tree, and is, perhaps, the finest specimen of the kind in England. The next largest recorded trees of this species are in the Bishop of Durham's park at Bishop Auckland, one of which measures 11 ft. in girth.

"At a residence already exhibiting the signs of unusual magnificence, we trust that a portion of the park will be set apart for that most interesting and indispensable accompaniment to every gentleman's seat—an arboretum. By an arboretum, we mean a collection of all the trees that will stand the rigour of a British winter arranged in natural groups—a great congregation of the grand objects that adorn our country, whether in forests, fields, or cultivated gardens, brought together so that their beautiful and diversified characters may be seen and studied as if in a museum. The most of our extensive seats, formed within the last few years, have a portion of their pleasure-ground devoted to this important object."

*Westwick Park; Jack Petre, Esq.*—Celebrated for its pinasters, which cover extensive tracts of country, and for number, height, and bulk, are not excelled in England.

"The wonder to a stranger is, whence such a quantity of plants could have been brought, and why so many soft-wooded trees should be raised in preference to the *Pinus sylvestris*, which produces infinitely superior timber."

A very interesting account is given of these trees, which we would abridge, did we not believe that every person at all interested in the subject would procure the work. There is a pear tree with a trunk 9 ft. in circumference, and a Portugal laurel with a stem 5 ft. in circumference. "The horticulturist and florist will be equally delighted in visiting this seat, the general excellence of which must strike every one."

*The Oak Tree at Thorpe Market.*—This tree has been already mentioned. The engraving here given on a folding plate is very characteristic. The tree



is erect and exceeding well balanced ; it is 70 ft. high, with a trunk of 42 ft. : in its circumference at 1 ft. from the ground it is 21 ft. 6 in. Mr. Grigor thinks that there are few, if any, oaks which excel this tree in England.

*Sall Park ; Sir R. P. Jodrell, Bart.* — The park scenery is exceedingly pleasant, and contains some fine trees, especially a lofty and beautiful beech.

*Heydon Park ; W. E. Lytton Bulwer, Esq.* — A very ancient place, in which "all that a pure and enlightened taste would have suggested has been carried into effect. He who expects to find here the usual routine of park shrubbery, pleasure-ground, and the gay parterre sparkling in summer's beauty, will be disappointed. Such is not its character. It is of that grave and almost melancholy appearance which thick woody scenes brought near to the mansion usually confer — full of ancestral remnants. The visitor of Heydon will at once be impressed, we think, with the peculiar feature by which we have considered it is so much characterised — that of pensive grandeur. The entire place is a testimony of the wonderful effect which trees produce on a surface like that of Norfolk, which in general is naturally uninteresting."

*Hoveton Park ; Mrs. Burroughes.* — "A seat of general excellence," remarkably well laid out, and highly kept. "The whole place is so judiciously laid out, that we hazard the opinion that it has been done by some one who has become eminent in his profession."

*Scottow Park ; Sir H. Durrant, Bart.* — A seat with many traits of beauty, and some fine trees. A pyracantha covers a space on the walls of some outbuildings 24 yards in length, and is clad with large bunches of brilliant scarlet berries in November. We may observe that it is rather remarkable that this thorn is not more frequently grafted standard high on the cockspur thorn ; or perhaps *C. mexicana* would be preferable as a stock, from being subevergreen. "The kitchen-garden is celebrated for its great espalier-tree. Its high wall, which is reckoned the finest in Norfolk, is covered with wide-spreading vines."

*Our Trees.* — No. 6. *The Weeping Willow.* There are many fine specimens in Norfolk : one raised from the St. Helena specimen, in the garden of John Stracy, Esq., at Sprowston Lodge, is 27 ft. high, with a stem 3 ft. 6 in. in girth.

On the whole, this is a most delightful book of its kind ; it improves much as it proceeds, and more especially in the engravings, of which the number given is so considerable, that we are surprised at the low price at which the work is sold. We should think it could hardly fail to find its way into the library of every lover of trees.

ART. III. *Catalogue of Ornamental Plants grown and sold by Fowlds and Lymburn, Nurserymen, Seedsmen, and Florists, 36. Portland Street, Kilmarnock.* Single sheet, 1840-1.

*Select List of Hardy Trees, Shrubs, Ligneous Climbers, and Green-house Plants, cultivated and Sold by William Young, of the Milford Botanical and Floricultural Nursery, near Godalming, Surrey.* Single sheet, 1840-1.

*Catalogue of Nursery Stock, comprising Forest, Fruit, and Ornamental Trees and Shrubs, Stove, Green-house, and Herbaceous Plants, Florists' Flowers, &c., cultivated by William Gregory, Cirencester, Gloucestershire.* Pamph. 1840-1.

In each of these catalogues an endeavour has been made, and, as far as we can judge, successfully, to adjust the nomenclature to that of our *Arboretum Britannicum*. The collections of ornamental trees and shrubs in these three nurseries, stationed in widely different parts of the country, surpass those of 1841. — I, 3d Ser.

most of the London nurseries ; indeed we might almost say of any of them, except those of Hackney and Fulham. The truth is, that land and labour are so much higher in the neighbourhood of London than they are in the provinces, that the metropolitan nurserymen, now that the prices of all plants have fallen so low, cannot afford to grow complete collections. The public are gainers by this change in price, and it matters little to them whether they buy in town or country ; and the nurserymen, as a body, are no losers, because orders which a London nurseryman cannot execute from his own grounds, he can always, by means of such catalogues as those now before us, execute by procuring the plants from his friends in the country. The formation of collections in so many places throughout the country cannot fail greatly to increase the growing taste for trees and shrubs, which are the only permanent and independent (we mean comparatively independent of care and culture) ornaments of parks and pleasure-grounds.

By comparing these three catalogues with one another, it will be found that each contains several articles that are not in either of the other two, and hence from the other two each may be enriched.

---

ART. IV. *Catalogue of Works on Gardening, Agriculture, Botany, Rural Architecture, &c., lately published, with some Account of those considered the more interesting.*

*RUSTIC Architecture.* The picturesque and pleasing Appearance of rough Wood, Thatch, &c., when applied as the only Decorations of rural Buildings, illustrated by 42 zincographic Drawings, consisting of Plans, Elevations, Sections, and Perspective Views ; the Doors, Windows, Chimney Shafts, &c., drawn geometrically to a large scale, with a Description and the estimated Cost of each Design. By T. J. Ricauti, Architect. Printed for, and published by, the Author, at his Office, No. 26. Foley Place ; and to be procured through any Bookseller. London, 1840.

We have repeatedly and strongly recommended this elegant and useful work to our readers. The sixth and last part, now before us, brings it to a conclusion, and we can safely say that we think no gentleman who purchases it will be disappointed. The total number of plates is 42; and each is carefully described, with estimates and other details, as noticed in the titlepage.

*The British Almanack ; and the Companion to the Almanack for 1841.* 12mo. Price 4s.

Among the various matters in the *Companion*, interesting to the British gardener, the first we shall notice is an act past in August last, empowering the Duke of Marlborough to raise 25,000*l.* on mortgage, for the purpose of repairing Blenheim Palace ; and also to cut down and sell timber at the rate of 1000*l.* a year, for the purpose of paying the interest of the money borrowed. We trust the present duke will exhibit more taste in laying out this money than his predecessor, who, independently of allowing many parts of the place to go to decay, ruined the effect of the pleasure-grounds by covering the surface too uniformly with trees and shrubs. The first grand step in the improvement of Blenheim will be to undo great part of what has been done.

Chap. xix. is on public improvements, and is written with the usual taste and knowledge which have for several years past characterised this part of the *Companion*. The London cemeteries are described, and one is noticed as in progress at Winchester. Several public schools are noticed ; and engravings given of the Camberwell National Schools, and of Lady Owen's School, Goswell Road. Both are very handsome, and it is not a little gratifying to see schools keeping pace with churches and theatres.

The Derby Arboretum is noticed with discriminating taste and judgment.

“We will not say that hitherto too much attention has been paid to the physical necessities of the poorer and labouring classes,” says the writer, “but unquestionably too little has been bestowed upon their mental ones, as if they were unworthy of being indulged with any kind of amusement except the brief and riotous one of a holiday or fair; which being the case, it is not matter of surprise, however much it may be for regret, that the bulk of the population in manufacturing and other large towns should have no relish for simple quiet recreations, or derive any gratification either from natural beauties or from those of art. Through the beneficent liberality of Mr. Joseph Strutt, Derby has been enabled to set an example to other towns in the kingdom; that gentleman having bestowed these pleasure-grounds on the corporation, upon the condition that they shall be open to all classes of the public without payment (and subject only to such restrictions and regulations as may be found necessary for the observance of order and decorum), on every Sunday, and also on one other day in every week, from sunrise to sunset.” (p. 251.)

## MISCELLANEOUS INTELLIGENCE.

### ART. I. *General Notices.*

*The Gardener's Book Society of Croydon* consists of about twenty gardeners, who subscribe 6d. per month, which enables them to purchase most of the gardening and some of the botanical periodicals. Societies of this kind might be formed in all towns having populous neighbourhoods, and persons would frequently be found to join them who are not professional gardeners but only amateurs. The West London Gardeners' Association has set a noble example in this respect for the larger towns, and the Croydon Society for the smaller, and for the villages. Nothing is to be done in gardening in the present day without constant reading, and vigilant watching of all that is going forward.—*Cond.*

*Botanic Garden Reports of new Trees and Shrubs.*—I have been thinking that you should urge your claim upon all the botanic gardens, and other public gardens, for making an annual report of all the new hardy trees or shrubs raised in them, like that made by me. I certainly am surprised that this has not been done before this by the curators of these gardens, Mr. Cameron being the only one who has even attempted any thing of the sort. I think if such reports were annually given, they would be the means of making many plants known which remain in obscurity for years; they would also confer a benefit on the trade, by letting them know where such plants were to be had; and would show how much each garden contributed, in the way of novel or useful plants, to the general collection of the country; and all of us would be greatly benefited by such. As it would be but once a year, there could be no excuse in not having time; and there is always means of obtaining the names, and particularly now when we have postage cheap. I shall always be happy to render any assistance in my power, to any person, in comparing specimens with those in the Society's collection, or in letting them know if they are new to me, provided that this is not attended with any expense to me. I leave the subject now in your hands.—*George Gordon. Horticultural Society's Garden, Chiswick, Nov. 21. 1840.*

*Cucumber and Melon Culture.*—I am about to publish my system of cucumber and melon culture, on the trellis, in a brick pit that I had erected here about four years since. It is impervious to steam, and easily heated and managed, so much so, that with ordinary attention success is certain, and the cucumber brought to the greatest perfection at any season. I have grown the melon on the trellis in a pit on the same construction for the two years last past, with the best success. The fruit lying on the trellis ripens much

better, and is not liable to crack and rot, as when nearer the ground; it is a decided improvement in the culture of early and late melons. My book will also include my system of hand-glass culture of rock melons, and the common method in frames on dung beds; also my method of growing and forcing asparagus and sea-kale. — *John Mills. Guinersbury, Nov. 6. 1840.*

*Garden Syringes.*—You have often noticed the great excellence of Reid's syringe for every purpose of the cultivator; also M'Dougal's, the bend of which renders it indispensable. These are confessedly the best syringes of the present day; but are they perfect? So far from this being the case, any practical man, after working these for half an hour, could give directions for making a better instrument. For every straightforward purpose, Reid's is all that can be desired; but by it we cannot possibly reach the covert insidious marauders that so unceasingly annoy us. It is by an instrument throwing up a perpendicular jet, that we can effect this. Therefore a right-angled bend, put upon Reid's syringe, would render it by far the most efficient instrument in use. It may be supposed that M'Dougal's syringe, having a bend, would accomplish all this; but this is only partially the case. The aperture which admits the ingress of water, is by far too small to fill in any reasonable time the vacuum created by the working of the piston, and thereby renders the operation both tedious and laborious, causing a great deal of power to be spent wholly in vain; and the bend is set at such an angle, that when the instrument is held horizontally by the operator (which is not generally the case), the jet produced, instead of being perpendicular, is thrown directly in the operator's face. Thus the properties of these instruments, imitated and improved, would be a valuable combination; and it is a pity that the patented protections of these gentlemen should deprive the public of what would be so really useful. — *M. T. Sept. 1840.*

*Autumnal Colouring of Quercus and Rhús.*—We have received from J. T. Brook, Esq., of Flitwick, specimens of *Quercus* and *Rhús*, more splendid in colouring than any which we have hitherto seen. The Flitwick Arboretum was planted in 1829, and hence these trees have upwards of 10 years' growth. The colours of all the leaves are of the most intense scarlet, in the case of the *Rhús* tinged with dark purple. The species are *Quercus palustris*, three varieties; *Q. falcata*; *Q. rubra*, of a dark red, almost black; *Q. champaniënsis* *Lod.*, with very large foliage, very dark red; and *Q. Banisteri*, dark brown red; *Rhús suaveolens*, of an intensely dark purple; *Rhús typhina*, of an intensely deep scarlet; and *Rhús glabra*, of a scarlet so dark as to be almost purple; *Rhús Côtinus*, the leaves of which generally die off yellow, but in this instance they are of a fine scarlet, with a glaucous yellow beneath. No lover of trees could see these specimens without being enchanted with them, and, if he has not already an arboretum, rendered irresistibly desirous of planting or visiting one. — *Cond.*

*American Oaks.*—A collection of very beautiful specimens has been sent us by M. Vilnorin, from his extensive plantations at Barres, and of which we hope he will favour us with a history. The following are the names of the species received, and the dimensions of the current year's shoots and leaves.

- Quercus álba* *L., Mich.* Leaves  $7\frac{3}{4}$  in. long, by  $3\frac{3}{4}$  in. broad. Young shoot  $8\frac{1}{2}$  in.  
*nigra* *L., Pursh.* Leaves  $5\frac{3}{4}$  in. long, by  $4\frac{1}{2}$  in. broad. Young shoot 3 in.  
*Phellos* *L., Pursh, Mich.* Leaves  $4\frac{1}{2}$  in. long, by  $\frac{7}{8}$  in. broad. Young shoot  $9\frac{1}{2}$  in., branched.  
*macrocarpa* *Willd., Mich., Pursh.* Leaves  $12\frac{1}{2}$  in. long, 7 in. broad. Young shoot  $4\frac{1}{2}$  in.  
*Prinus discolor* *Mich. fl., Pursh.* Leaves  $7\frac{1}{2}$  in. long,  $5\frac{1}{2}$  in. broad. Young shoot 5 in.  
*Prinus monticola* *Mich., Pursh.* Leaves 8 in. long,  $2\frac{1}{2}$  in. broad. Young shoot 3 in.  
*rubra* *L., Mich., Pursh.* Leaves  $11\frac{1}{2}$  in. long,  $8\frac{1}{2}$  in. broad largest leaf. Young shoot 6 in.  
*heterophylla* *Mich., Pursh.* Leaves  $6\frac{1}{4}$  in. long, by  $2\frac{1}{4}$  in. broad. Young

shoot  $7\frac{1}{2}$  in. Most of the leaves more or less lobed, but some resembling *Q. Phellos*.

*Qu. falcata Mich., Pursh.* Leaves 7 in. long, by  $4\frac{1}{2}$  in. broad. Young shoot  $7\frac{1}{4}$  in.

*palustris Willd., Mich., Pursh.* Leaves 7 in. long, by  $4\frac{1}{2}$  in. broad. Young shoot  $5\frac{3}{4}$  in.

*obtusiloba Mich., Pursh.* Leaves  $5\frac{1}{2}$  in. long, by  $3\frac{1}{2}$  in. broad. Young shoot  $2\frac{1}{2}$  in.

*tinctoria Willd., Pursh.* Leaves  $8\frac{1}{2}$  in. long, by 5 in. broad. Young shoot  $10\frac{1}{2}$  in. long.

*Banisteri Mich., Pursh;* *ilicifolia Wang.* and *Arb. Brit.* Leaves  $4\frac{1}{2}$  in. long, by  $2\frac{1}{4}$  in. broad. Young shoot  $4\frac{1}{4}$  in.

*lyrata Walt., Mich., Pursh.* Leaves  $7\frac{3}{4}$  in. long, by  $3\frac{1}{4}$  in. broad. Young shoot  $10\frac{3}{4}$  in. Plant 3 years' seedling. — *Cond.*

*Artificial Maturation of Figs.*—A traveller from the Levant taught me the following mode of rendering full-grown figs fit to eat. I take a blunt-pointed bodkin, such as women use in drawing through tape; I open the orifice at the end of the fig, and at the same time, having a little bottle of sweet oil hanging on a button of my coat, I dip the bodkin in the oil, and insert one drop in the orifice. — *Thomas Blake, Gardener. Shirley Park, near Croydon, June 15, 1840.*

In the notes made during our visit to Paris in 1828, and given in Vol. VII. p. 262., we described the practice related above, as seen by us put in execution in the fig orchards at Argenteuil; all the difference is, that a bit of wheat straw is there used instead of the bodkin. — *Cond.*

## ART. II. Foreign Notices.

### SOUTH AMERICA.

*RIO JANEIRO, Sept. 26, 1840.* — Here I am at last in an almost tropical climate, and under an almost tropical sun, only  $80^{\circ}$  in the shade, and we are yet only on the end of the Brazilian winter. But where shall I begin, and where shall I find an end to describe to you my daily, my hourly botanical enjoyments and raptures? I am quite sure \* \* \*, when he was transported in the spirit \* \* \*, could not feel himself more charmed than I was the day before yesterday, finding myself with the celebrated traveller, Riedel, in one of the remaining small portions of primitive forest behind Corcovado Mountain, surrounded with tree ferns and myrastics and melastomas and rhexias and epiphytes and pothoses and Piperaceæ and bambusas, &c., under a concerto of chirping and humming giant-grasshoppers and minute colibris, and loud-screaming many-coloured parrots, and whistling ugly monkeys, and all that only two or three leagues far from the Emperor of Brazil's residence, the good city of Rio Janeiro. I assure you I pinched myself already many times in full earnest, to see if I was awake, or dreaming only of a charmed fairy land. But, poor mortal as I am, I must soon return in this misery of human life, to tell you that I am not a little embarrassed, having failed until now in my project to support myself with German and French lessons until I could send to Europe large collections of plants, seeds, insects, &c. I trust, therefore, in your long friendship not only, but also in your zeal for botany and horticulture, to recommend as soon and as powerfully as possible my poor exertions to generous amateurs, in order to keep me alive amidst all these treasures. In revenge, if you carry in effect these mine projects by procuring me generous protectors, I shall show you my gratitude by all kind of contributions to your Magazine, collections, &c., whatever you may like or wish to possess from this here charming country. Only arrived a fortnight ago, all my ideas are so excited, that it would be impossible for me to give you for the moment a sober description of any kind of object. If you will answer this letter, you must recommend it to the care of Mr. Ousely, H. B. M. Chargé

d'Affaires, in Rio Janeiro; and then I shall give you an account of all what I shall have seen until then. — *D. I. F. Lippold.*

We sincerely hope that such of our readers as have the taste and the means will patronise this excellent man, and scientific, and we need not say enthusiastic, botanist. He may either be addressed to the care of the British consul at Rio, or orders will be received by Mr. Pamplin, Natural History Agent, No. 9. Queen Street, Soho, who will take charge of articles sent home by Dr. Lippold if required. The postage to Rio is 2s. 3d. — *Contd.*

### ART. III. Domestic Notices.

#### ENGLAND.

*NEW or rare Plants lately raised in the Botanic Garden, Liverpool.*—*Béssera* élégans, a bulb collected in Mexico by W. Bates, Esq., figured in the *Berlin Hort. Trans.* for 1839, t. 4.; *Deützia stamínea Wallich*, figured in *Flora Asiatica*, which has stood against a wall facing the east for the last three winters, without protection, and without injury; *Lýcium obovatum*, quite hardy against a wall; *Lopèzia miniata*, a frutescent plant, raised from seeds collected by William Bates, Esq., not yet tried in the open air, but apparently quite hardy; and a new *Búddlea* from Mexico, with fine broad leaves, and a free flowerer, which has stood out the last three winters, and appears quite hardy. The seeds of this I also received from Mr. Bates.—*Henry Shepherd. Botanic Garden, Liverpool, Dec. 1. 1840.*

*The Cotton Plant* has been grown in Manchester from seeds of the Sea Island cotton brought from America, and pods produced containing cotton fit for use. (*Lit. Gaz.*, Oct. 31. 1840.)

#### SCOTLAND.

*Timber Bridges.*—Mr. Mitchell related to the British Association his experience in constructing timber bridges in the Highlands of Scotland. He mentioned, among several others, three of 75. ft. to 100 ft. span, over the Spey and Dec. He considered that timber bridges would last from thirty to forty years; but such was the economy of their structure in comparison with other bridges, that the prime cost would more than allow their being rebuilt. (*Lit. Gaz.*, Oct. 31. 1840.)

### ART. IV. *The West London Gardeners' Association for mutual Instruction.*

*MONDAY Evening, April 13. 1840.*—Mr. John Fish read his paper *On the Forcing and general Cultivation of the Strawberry.* He gave a brief history of the plant, and of its medicinal properties, and then detailed the practice of some gardeners in forcing the fruit. They lift two-year-old plants, putting them with good balls in 24-sized pots, and then commence to force them immediately; last year's runners are recommended by others to be potted in February, taking off the blossoms as they appear during the growing season, to prepare them for forcing in the autumn: to these plans he objected, as there would be a great loss of time and of labour, and the fruit would not be so fine, as the best is obtained during the first season of growth. His practice was, to prepare strong warm or any good rich soil with one third decomposed hot-bed dung in July, or as soon as rooted runners can be obtained, potted in 48 or 32-sized pots, with 2 in. of well decomposed dung above the crocks, one plant in each pot. When taking them from the old plants, to pull up an armful of the runners, dressing, potting, and shading them at the north side of a

wall until they get sufficiently rooted ; when they are gradually exposed to the influence of the sun, then plunged in sawdust, and abundantly supplied with water, removing all runners and weeds as they appear ; to be covered with straw or litter from frost. If convenient, the best way would be to take them, at the approach of winter, under cover ; but, if not, they should be placed on a north aspect about the end of September, keeping them rather dry. A great advantage was derived from placing the pots on their sides, which prevents the rain from entering, and the frost from injuriously affecting them, as, when overcharged with moisture, the sap vessels are distended ; in frosty weather, the sap is expanded, which brings on disease, and ultimately the destruction of the plant. If fruit is wanted at Christmas, to commence in October, unless they are forced in pits ; to commence at 45°, gradually raising the temperature, when the plants are in blossom, to 65° and to 70° ; when ripening the fruit, keeping the plants near the glass, admitting air at all favourable opportunities ; when the fruit is set, to be watered with the drainings of a dunghill. His method for a general crop was, to take them into the vinery when forcing was commenced. About the second or third week in November they were placed on flagstones above the hot-water pipes in front of the house, then regularly supplied with water, air admitted at all favourable opportunities, decayed leaves removed, stirring up the surface mould with the addition of fresh soil, and supporting every truss of fruit with a small stake ; they were more exposed to the influence of the sun, by which aqueous is changed into saccharine matter. A second and third crop were produced from the same plants, which was attributable, in a great measure, to the manure placed at the bottom of the pots, and watering twice or thrice a week with liquid manure. A second vinery was started about the end of January, in which strawberry plants were placed and treated as the first ; a third was started about the beginning of March. From the three houses fruit was obtained from December until they could be procured out of doors. The sorts were the Alpine, Roseberry, Wellington, and the greatest portion Keen's seedling. The Alpines were first excited in a small hotbed, and taken into the vinery, when they showed flower-buds. The opinion generally entertained, that strawberry plants, French beans, and potatoes have a tendency to introduce insects into the vinery, was never confirmed by his experience. For the destruction of red spider, a good coat of quicklime and sulphur, of the consistence of paint, brushed over the pipes or flues two or three times ; and green fly destroyed by fumigations of tobacco. He recommended pans of water to be used as feeders, to be regularly supplied until the fruit begins to ripen ; to be then gradually withheld to produce fine-flavoured fruit. Air is advantageous in all stages of their growth, but more particularly when in flower, and during the time the fruit is setting ; for which purpose pits are preferable to houses, as they can always get a more abundant supply. On the great importance of light, heat, and air, he showed that heat was the natural stimulus for setting the vegetative powers of plants in motion : heat without light, in most instances, is injurious to vegetation ; it is when one is proportioned to the other, that vegetation advances to the greatest maturity. Between the tropics, where a high temperature exists, and with full exposure to light, vegetation is almost continually going on, affected more or less by the alternations of day and night, and plants flower and fruit twice a year. This is owing to the temperature being suitable to vegetation ; and no sooner have the plants performed their natural functions, than they, after a short cessation, again commence producing as before. He then went into a physiological investigation, to prove that when a plant is exposed to the full influence of the sun's rays, it gives out pure oxygen, and absorbs carbonic acid, which goes through the process of decomposition in the plant, the carbon only being retained. This operation cannot go on in darkness ; the plant then giving out carbonic acid and nitrogen gases without oxygen will soon get into a diseased state, and ultimately perish. To some persons the observations just made may appear theoretical, but he believed that they were necessary to under-

stand the first principles of our operations. For out-door management, his method was, to plant them out, when done bearing, in a trench 1 ft. deep, with 2 or 3 inches of well-rotted dung at the bottom, a little soil strewed over it; turned out of pots, balls entire, and placed very close to each other; an abundant supply of water to be given, and the soil filled in level. Plantations of strawberries in strong rich soil, trenched 2 ft. deep, would produce well for three years, but on light soils he recommended to renew them every year. After detailing many particulars about the sizes of the beds, the proper distances to be planted apart, and the other minutiae of general routine, he concluded by recommending the Roseberry, Keen's seedling, Downton, Wellington, Carolina pine, red and white Alpine, and Wilmot's superb, for general cultivation.

Mr. Gray would advise to take small 60-sized pots, to be filled with leaf mould, then plunged in the borders or beds, that the runners may be pegged down; when established, to be cut from the parent plant, and placed in 32-sized pots, in good loam. After forcing, to be planted out; when put into the house, all decaying leaves to be removed, and very little water to be given; the supply to be gradually increased until the fruit is set, when it may be given copiously; to be withheld when the fruit is ripening, to improve its flavour. The temperature to commence at 55°, to increase it gradually to 65°, and to ripen them at 70°.

Mr. Sherwood, in his management of runners, filled 60-sized pots with stiff soil, then plunged them to their rims, stopped the top of the shoot, laid a small stone to fix it in the pot; when established, shifted into 48-sized pots, plunged in old tan, or in any favourable situation in the open ground, and always fruited them in 32-broad-sized pots.

Mr. Caie considered the most essential thing in forcing strawberries was to place them near the glass, for, if they are in any way elongated, they will not set well. It was a good plan to set the pots in pans of water, and to plant 3 in each pot.

Mr. Gray believed that the soil in a 32-sized pot will not contain more nourishment than is sufficient to support one plant. To be protected in a covered shed or out-house in winter, as he has seen plants much injured by the frost. He preferred to plunge them in tan, mulched with sheep-dung; if saturated with water, they are very apt to rot off.

Mr. Keane approved of the essay brought forward by Mr. Fish. The practice he would recommend was, to put 3 plants in each 32-sized pot, filled with one third rotten dung, and two thirds good stiff pasture loam, well drained, and plunged as Mr. Sherwood advised. To commence forcing at 50°; sheep-dung manure-water to be given when the bloom was falling, and to be continued for three weeks to set and swell the fruit.

A desultory discussion then took place on the advantages or disadvantages of liquid manure; on the propriety or impropriety of cutting down the leaves; and Mr. Fish concluded by recommending to bring on vegetation gradually, to protect the plants when plunged by spreading any dry litter over them, and to grow them without suffering from the checks that vegetation generally receives in shifting from one pot to another. — *Walham Green School-Rooms, Dec. 1840.*

---

#### ART. V. *Retrospective Criticism.*

*CHATSWORTH, Alton Towers, and Trentham.* — I have just returned from these places. *Chatsworth* retains with me its grandiose character. Its rich interior fine dooreases of such size, and its shadowful cornices and ceilings, take it out almost of the common dwelling to the palace character. I think a mistake has been made in carrying the landing, which is so disagreeably narrow,



round the hall, by way of preserving the communications for the purposes of habitation. I think if it had been taken only along that side of the hall which faces the court, its width might have been handsome; and it could have been broken into projections upon brackets, corbels, or cantilevers, with very fine rich effect, and the convenience of the communications equally maintained. The ceiling of the great dining-room was not, to my view, an agreeable segment, and the statues which form the chimney-pieces are not upon an agreeable level. They would seem to be part of the company, and do not maintain their illustrative and decorative character. Such were the crowds of visitors, that I had the advantage of seeing these gardens peopled; and, as at Versailles, it is a most advantageous carrying out of the fundamental views of the designers of that section of gardening. I hope that the duke, who is always so alive to the completion of his magnificent residence, will make a grant of his notice to the termination of the architectural cascade. It would double its value were it decorated by architecture and statues and seats of stone, which should be so consulted in the composition of them, as not only to banish the nudity of the immediate scene, but furnish decorative points of view to other parts of the gardens. The old French works on this style of gardening offer a great variety of materials for such a composition. The great conservatory is yet without its plants. It is certainly very hideous in its forms, but surprises from its magnitude. It seems very ill built, and of very inferior materials, both wood and glass. The collection of plants of so many different kinds is very amusing, and they are in general very well conducted as to management. The glazing by a groove in the sash-bar does seem the best mode yet hit upon; and, if I can get over the difficulty of working the panes, I feel disposed to prefer it for my own houses. At Chatsworth they seem to make no difficulty about it, which ought to make it appear very practicable, especially when there is so much done there in that way.

*Alton Towers* always amuses me; and, although there is much of the ridiculous done away with, I doubt whether much of it must not be set down to the category of whim and caprice, rather than to ripened or artistical taste. It is one of the multitude of instances in England, and applies to the last half-century, beginning at Strawberry Hill up to the very spot, how feebly the subject intended to be created, or even imitated, has been understood by the employer; and how still less intensely the architect or adviser has been acquainted with first principles, or brought to his work a sober feeling, or even educated attention. I even require that, as in other arts, the artist or architect should aim at ideal beauties, cull them, and not confine himself to copy. This is quite compatible with an adhesion to any period or style which may be selected. The contrary or opposite view conducts him out of art, strictly so called, and reduces him to the pedantry of an antiquarian, which must, or ought to be, anything but the plan for imaginative exertion. I believe that that radical, Luther, contrived to inveigle away his generation, and those that have followed it, out of that expansiveness of imagination which is so indispensable for art. The house is full of fine gorgeous furniture and pictures. The galleries are too low, I thought, and not very agreeably lighted. The descent to the dining-room, so far from being made into any thing fine, for which a flight of steps is so admirably adapted, is quite the contrary: it is rather ridiculous to see a company arriving at their dinner table *à vol d'oiseau*; for it is a very precipitous descent, and the circumstance of winding round must destroy all the pageantry of such a proceeding. The idea of descending from a height (but only moderately so) to a dinner table of display is calculated to have a very good effect. The pattern of the dinner table, like the pattern of a symmetrical flower-garden, gains by being looked over by an eye somewhat more than six feet above it, rather than looked along by an eye at the common height: Paul Veronese has put this often in practice in his compositions. The most beautiful pictorial effects, and a true realisation of the purpose and sensual character of a pageant feast, are at once displayed to those senses most upon the look out for these gratifications; and my recollections serve

me easily in the effect produced on myself at the sight of a most superb supper, served to the Imperial Family and court, in the theatre of the Hermitage Palace at St. Petersburg, by a similar arrangement. I could mention, also, the very varied effect that can be thus made use of in the disposition of a large and crowded company, in the court fêtes given at the Favorita Palace, near Portici, by the court of that country; and at several others, which, as is usual on the Continent, are placed under the direction and invention of educated artists, when the fête is for the celebration of any royal alliance or other state purpose. I must not be tedious, but perhaps this may suggest a hint, through your journal, to our plodding idle school of architects, and surprise or awaken their drawing-boards.

*Trentham* has many unfortunate circumstances belonging to it. The house is so confined by roads, and that fine expanse of water is continually thrusting itself on the eye, and forcing it in vain to look for an outline that is not graceless. The house is altogether little, inside and out. It would be a fine villa, and ought to be at Turnham Green or Wimbledon. It is wholly silent in inspiring any notions of seigneurial or aristocratic feeling, such as seem belonging to this puissant family. The flower-garden is the only great thing about it. That compartment next the house is very successful; the lower one wants dressing. I think there would not be too much grass, if the beds had handsome stone borders or edges. It should not have gravel, I think, otherwise the whole would be a glare. Its great defect in design is its tameness. It wants a boundary of clipped bosquets or berceaux, to give some light and shadow, and to define more strongly its beginning and separation from the park. The bronze statues do well near the architecture of the house, but, if deprived of that accompaniment, they cease to assist in the general effect, and incur the charge of being misplaced. Against a Portugal laurel they come off badly, and can only be of value when close to them. — *H. B. August 18. 1840.*

The above communication was sent us long after we had written our remarks on the same places, made in May, though not published till November. As we consider the taste of the writer to be of the very first order, both in architecture and landscape-gardening, we feel much gratified and strengthened in our own views, from their coincidence with what we consider so high an authority. With respect to the conservatory at Chatsworth, there can be no doubt that a classical form would have been more generally approved of; but much of the approval and disapproval in such matters has its origin in previously formed associations. Whenever any form is presented to us so entirely new as that of the conservatory at Chatsworth, it ought to be tested by its utility; and few, we think, will deny that the structure in question is admirably adapted for all the purposes of the kind of culture intended, the enclosure of a tropical grove. We are surprised to hear the workmanship and the materials objected to, for, when we were on the spot, we thought them both excellent. — *Cond.*

*Mr. Penn's Mode of heating Hot-houses.* — I feel that in my paper on Mr. Penn's mode of heating, which appeared in your Volume for 1840, p. 640., I ought to have cautioned persons against erecting the apparatus as at first applied by the inventor, or as figured in the *Gardener's Magazine*, volume for 1840, p. 122—127. This is the more necessary, as in distant countries, or even in distant parts of this country, many persons in erecting it may follow exactly the sections and descriptions given in the Magazine, and the result must be a failure; as to heating an early forcing-house sufficiently, with the pipes placed outside, it would in particular cases (high winds for instance) amount to an impossibility. But allowing it could be accomplished, it must be at an enormous sacrifice of heat; as much heat is absorbed by the materials that encase the pipes, which when placed outside must be given out in the back sheds, without in the smallest degree benefiting the space intended to be heated. When the pipes are placed inside, this circumstance becomes a great consideration, as I find the materials so heated continue to give out heat

long after the water ceases to circulate; therefore, the pipes ought in every case to be placed inside of the house or houses to be heated. Knowing how willingly you give publicity to every improvement, I trust you will insert this correction, as it may prevent disappointment, and do justice to a system that when properly constructed is preferable to all others. — *N. M. T. Folkestone, Dec. 8. 1840.*

*Mr. Penn's Mode of Heating, as contrasted with other Modes.* — I think it is much to be regretted that Mr. Penn did not prevent the possibility of mis-construction by taking out a patent, and keeping it in his own hand till perfectly understood, thereby securing it to the public with every improvement that experience might suggest. But he has given up his indisputable right to do this, and has apparently gained nothing in return — no, not even the thanks of those who might have profited most by his, as it appears, ill-bestowed liberality. Having by leaving his invention open for the good of the public waived all claims to the golden harvest it must otherwise have produced him, it might reasonably be supposed that he would have been allowed full credit for his ingenuity. To retain the shadow, after so generously parting with the substance, is even denied him. Mr. Fowler, in his paper on the subject, Vol. for 1840, p. 323., says it is *no* invention; still he insists on having this nothing divided, and proposes to share the palm with Mr. Beaton, by which it is evident that he considers discovery and invention the same thing. I think the two modes very different, and consider that had Mr. Beaton or any other man, by erecting an apparatus to answer any other purpose, found out Mr. Penn's system, it would have amounted to a discovery, an accidental discovery only, an effect produced, without, in all probability, the producer being able to define the cause. How different is the case with reference to Mr. Penn! He saw the desirableness of the revolution he has effected, directed the energies of a vigorous mind to produce it, and the result has been his system as it now stands, based upon unerring principles, effective, grand, and simple. All this, says Mr. Fowler, is as new as chimneys, which he informs us were invented by the good people of the thirteenth century, by which it is evident that they knew that "sparks fly upwards," and probably that they knew hot air ascended also; but, if they had not found out this, many a poor gardener, to his cost, had been left to the necessity of turning every sash into a chimney that the smoke might escape into the atmosphere. Thus, in these matters, according to Mr. Fowler, we have been stationary since the thirteenth century; and all parties might have been as fully satisfied with the chimney system as he is, and we might have remained so for thirteen centuries more. But Mr. Penn has at length grasped this column of heated air, hitherto stubborn as the monument, and bent it to his purpose, making his invention, as Mr. Fowler has unwittingly expressed it, a truly retrograde movement. The air of a house, Mr. Fowler observes, heated by pipes, cannot become stagnant; the same with equal justice may be said of the most stagnant pond that fosters pestilence: still, strictly speaking, this is correct; practically speaking, it is sheer nonsense. The air of such houses is often stagnant, palpably stagnant, to a degree highly injurious to the interests of the cultivator; yet in the same breath Mr. Fowler informs us that the air in Mr. Penn's houses must become so, and forthwith consigns it a habitat in the drains! Yes, in the drains, the current that rushes through which and agitates the waves of this ocean is compared to the force of the whirlwind, the rage of the tornado. Had there been a possibility of what he surmised happening, it would have shown a much better feeling to have proposed a remedy, than to have opposed by "weighty objections" a plan, which, at the time he wrote, it is evident he knew nothing about. These weighty objections are, I may add, probably the most harmless things that ever assumed so formidable a name, as, according to his own showing, they could not possibly exist. — *N. M. T. Folkestone, Dec. 9. 1840.*

*Mr. Rogers's Conical Boiler.* — As my sole object, with reference to the

conical boilers, has been that the public should have the benefit of them, such as it may be, in the most efficient form, I think it but fair that all who have lent themselves to the carrying of my plans into execution should share equally the advantage, such as it may be, of my recommendation. I find that Messrs. Lankester and Co., of Southampton, to whom I communicated my suggestions as long ago as 1836, have carried them into execution very extensively, and with great success. They continue to employ copper boilers, not having experienced the inconvenience which I found in the use of that metal; and, though I confess I have some misgivings as to its durability, my single experiment cannot be considered as conclusive against it. I have not had the advantage of seeing any of the apparatus erected by them at work, but the numerous instances of their successful application which they have handed to me, and the general efficiency with which all their undertakings are conducted, leave me no room to doubt that they would execute satisfactorily any work which may be intrusted to them.

In taking leave of my now almost jaded hobby, I would once more suggest that it is essential that the conical boilers should be set, or the setting actually superintended, by some one who thoroughly understands the principle upon which they are to act, or failure and disappointment will probably ensue. I should also mention that more extended experience has satisfied me, that the reverberatory mode of setting, in which the draft descends around the outside of the boiler before it enters the chimney, is invariably the best: boilers so set require less attention and less skill to manage them than those fixed as my own, and some of the earlier ones.

In conclusion, I must disclaim any merit for any thing more than the mere contrivance of the boiler itself; for all the calculations necessary for its application to produce any given temperature, both as to the size of the boiler itself, and the pipes which it is capable of heating, I am indebted to Mr. Charles Wood's most valuable treatise. My own experiments on these points have been few and very roughly conducted; and the results I deduced from them, though perhaps not very erroneous, were merely empirical, and applicable only to similar or not very dissimilar cases. I have relied entirely upon his experiments and calculations, wherever I have had occasion to advise the quantity of pipe which should be employed for any specific purpose; and I cannot neglect this opportunity of acknowledging his very obliging personal communications on the subject, whenever I have taken the liberty of conferring: nevertheless he is no way responsible for any blunders which I may have committed. The conical boilers are now in the hands of a great number of persons, and I am happy to find that general testimony confirms the favourable opinion I entertained of them; nevertheless, I am far from believing that other boilers of different form might not be made equally or more efficient, if constructed with the same attention to the purposes to which they are to be applied. — *John Rogers. Sevenoaks, Dec. 4. 1840.*

*Semicylindrical Draining-Tiles.*—In the *Gardener's Magazine* for 1840, p. 535., I am somewhat surprised to see it stated by you, that the semicylindrical draining-tiles are placed with the open side downwards, resting upon flat tiles. Now it is obvious that the contrary is the proper way of placing them; because by resting them upon the convex side, with the concave side uppermost, the whole force of the current, be it large or small, will be collected into one body along the centre of the drain, and by collecting all the force into the smallest possible space, it will generally be found to keep itself clear of sand or any kind of dirt that may, from time to time, be washed into it.

The only objection which I can discover, against placing the tiles with the open side uppermost, is, that the covers might be liable to be broken by the passing over them of loaded wheelbarrows, &c. This objection is, however, of such trivial importance, that it could easily be obviated by placing the drains sufficiently deep, that the covers might be buried 10 or 12 inches beneath the surface of the walks. Although this depth would be found quite

sufficient to guard the covers from injury, it is clear that the deeper they are placed the safer they will be. — *A. Saul. Castle Hill, Dec. 3. 1840.*

*The Glazing of the Chatsworth Conservatory.* — It unfortunately happened that I was in Ireland when you were kind enough to send the proof here of part of your November [1840] Number of the Magazine. In noticing the great conservatory at p. 572. you state that Mr. Drake glazed it with squares 3 ft. 9 in. long, at 1s. 4d. per foot square. You will remember my stating at the time I gave you this information that Messrs. Chance, the manufacturers, had desired me to say it was impossible for them to supply others at this price, as they did not realise any thing by the transaction. They were desirous of bringing this glass into notice, and had therefore offered to supply the quantity I required at a low rate, being at the same time in a great measure ignorant of the trouble and expense it would give them, as they had not manufactured glass of the size required before. When the conservatory was first projected, it was the intention to glaze it with small crown glass, but after great consideration, and a good deal of conversation with Mr. Drake on the matter, he wished me to try British sheet glass in lengths about 14 in. long; this drew my attention more particularly to the sheet glass, and, after making various experiments, I decided to do it with glass in one pane, or to use small crown glass. Messrs. Chance, equally desirous with me for the large squares, met my views in the most liberal way, and undertook to supply it at a low rate, which enabled Mr. Drake to glaze the house at the price mentioned. I am anxious your readers should be set right on this head, as Mr. Drake and the Messrs. Chance have been subjected to considerable trouble, and many persons have referred to me for the correctness of the statement.

I may add, that so satisfied and pleased am I with this glass, that I would recommend its adoption in all horticultural buildings, for strength, beauty, and ultimate economy; from its thickness, and the even manner which it beds down to the bars, so very considerable a quantity of fuel is saved in early forcing and stove plant houses, that the extra expense of glass would in many cases be saved in fuel alone in two years. — *Joseph Paxton. Chatsworth, Dec. 9.*

*The Conservative Wall at Chatsworth. Gardener's Magazine for 1840, p. 572.* — I have been much interested in reading the accounts you give of the conservative wall at Chatsworth. I wish I had such a one at command, I think I would clothe it still better; but unfortunately you have destroyed all the benefit to cultivators, by the arrangement you have given. The list would have been far more useful had you divided the plants: distinguishing those that had the benefit of the flue; those that were only protected by the coping, buttresses, and curtain; and those for which the coping and buttresses alone were sufficient guard. Could you not give such a list in a subsequent Number? [Perhaps Mr. Paxton will be so kind as to supply it.] I am sure it would be welcome to many as well as to myself. — *J. C. Kent. Chamber's Court, near Upton on Severn, Nov. 12. 1840.*

We trust some of our readers will enable us to comply with our correspondent's wishes, as to conservatory wall plants in general. — *Cond.*

*Shriveling and Shanking of Grapes.* — There has been so much discussion in your Magazine on the shriveling and want of size and colour in grapes, that I make bold to give my humble opinion also, more especially as I consider our friend W. H. (Vol. for 1840, p. 598.) not altogether correct in thinking that the shriveling proceeds from the border being too rich and stimulating. Crowded foliage will be injurious, as far as preventing free access to light and air. Nor do I acquiesce with our learned friend Dr. Lindley, in supposing that it proceeds from the roots being too cold for the internal atmosphere. I had vines under my care at Edgerston in Roxburghshire, in the spring of 1837, when the thermometer stood at 13° out of doors, and the internal atmosphere was 72°. The vines were planted on the outside of the house, with their stems wrapped up with moss (*Hýpnum*), and the border mulched. They were planted in a compost of strong hazely loam, formed from the sward of a pasture

thoroughly decomposed, and one fourth vegetable mould of decayed tree leaves, one sixth of good rotten horse and butchers' grub dung, and a little sheep-dung, with a moderate quantity of powdered bones and lime rubbish. The borders were frequently watered with liquid manure water from the drainings of a dunghill, and we never had a shriveled grape during the three years I was there ; and these grapes have never failed taking the first prize for the best-flavoured bunch at the Jedburgh Horticultural Society for many years past : and there are vineries in this neighbourhood that have borders not above 3 ft. deep, upon a gravelly bottom, which have not been renewed these fifty years, that have had abundance of shriveled grapes in them every year lately.

I think the foregoing remarks prove that it is neither the coldness nor the richness of the border that is the occasion of the shriveling. As to the foliage of the vines upon the rafters shading those on the back wall, and causing the fruit to shrivel, I think the circumstance may partly be accounted for in this manner. The disease does not operate till the fruit commences colouring, but it must have originated before that, say fourteen days. Vines are mostly, by superior cultivators, slightly syringed and steamed until they commence colouring. Might not those on the back wall, from being shaded, be longer cold and moist, and not get the free circulation of air that they would get upon the rafters ; independent of their other disadvantages of being so much farther from the glass, and consequently receiving less heat from the sun's rays, &c. ? Now, in my opinion, damp stagnant air is very much, if not altogether, the cause of the shriveling of grapes after they commence their second swelling. If there should not be a free circulation of air in the house they will shrivel, and if the weather be wet or cloudy they will not do with high forcing. I am certain, from experience, that W. H. is perfectly correct as to the air and keeping a dry atmosphere : also see *Gardener's Magazine*, vol. x. p. 137., and vol. xiii. p. 261., by Mr. Robertson. The remarks that follow on the same page, by Agronome's nephew, are no proof at all ; for crowding a rafter with superfluous vines was certain to bring disease upon the weaker-growing sorts ; and as to his green-house, I do not suppose the vines he planted in it were either Muscats or Frontignans. As to Mr. W. Grey's observations (Vol. for 1837, p. 501.), I can see no reason why grapes should either be overcropped or get infested with the red spider in a vinery, supposing that to be the reason ; and gardeners all know, or ought to know, that grapes set best in a high moist atmosphere.

An article or two have also appeared on the *Rust on Vines* (see Vol. XIII. p. 263. and 355.). The latter remarks seem to imply that it is occasioned by the foulness of the working gardeners' hands, &c. In the summer of 1830, my father-in-law had two vineries very much infested with rust on the vines ; it went on increasing every year till 1835, when he concluded that it proceeded from the roots. We accordingly dug out a trench the broad way of the border, leaving 3 ft. of border along the front of the wall, forking the roots as carefully as possible, and folding them up upon the 3 ft. border that was left undisturbed, and shoveling the soil clean out down to the clay. We then covered the bottom with lime rubbish, and beat it down to a sort of pavement or floor, putting compost on the top of that 18 in. thick. The roots were then carefully pruned and put on the compost, and the border filled with the remainder. This compost consisted of good rich loam, &c., thoroughly decomposed ; and of course the vines were pruned according as their roots had been disturbed. This process had the desired effect, it entirely cured the vines of rust. What strengthens my opinion as to the roots is, that I have a vine here at one end of a large vinery, where there is a cistern for holding the rain water that runs off the house in wet weather, and the waste-pipe discharging itself into the border has soured the soil at the roots of this vine, so that it has contracted rust. From what has been said, I think there could be no mistake about my father-in-law's grapes ; he always dressed and thinned them himself.

By giving my opinion on the shriveling and rusting of vines, I do not intend

to disparage those of the gentlemen before-mentioned, and must regret that the subject has not been taken up by an abler hand than mine, and one more accustomed to the pruning-knife than — *Robert Wilson, Gardener, Norton, Stockton on Tees, Nov. 16. 1840.*

ART. VI. *Queries and Answers.*

*PROPAGATING the Mistletoe.* — Will any of your readers, who has had some experience in propagating the mistletoe, favour me with a notice respecting the best method of raising plants of that parasite, stating upon what kind of trees they will best flourish? — *An Amateur Gardener and Constant Reader of the Magazine. Ashton-under-Line, Dec. 2. 1840.*

*Shanking of Grapes.* — Having seen in your Magazine for 1840, p. 598., the question again broached, “What is the cause of the shanking of grapes,” and that after all that has been said and written on the subject, the cause is still left undecided, I take up my pen to offer a few remarks. The paper that Mr. Fish read at the West London Gardeners’ Association gave no system that ought to be pursued, by which the disease should be prevented from showing itself. There is not the shadow of a doubt, in my opinion, that too many branches on a vine will cause shanking and shriveling. This is easily remedied by reducing the number of branches to the strength of the vine; but how often do we see that, after this has been done, the evil still exists? The varieties of Constantias, Frontignans, and Muscats are more liable to the disease than others, notwithstanding all the care that can be bestowed as regards ventilation and keeping the border in a porous state. Some years ago I used to be sadly plagued with shanking, but now I have seldom a bunch that is affected by it. What first led me to prevent the disease was this: I never observed a bunch that was produced from a spur, and that had been neglected by not thinning out the berries, to shank. By following up this observation, I concluded that cutting out the berries before they were stoned caused fermentation, and ultimately death to the parts affected: but if I left the thinning process till the cambium began to descend, that this acetic fermentation would not take place; and as the cambium does not begin to descend till the berries are stoned, I considered this would be the most proper time to thin the berries. Having a house here that is entirely planted with the varieties of Frontignans and Constantias, I determined to try the system that I had laid down to myself on the whole house. It succeeded, and has done so ever since. I never take a berry from out of a bunch of grapes till after the berries are stoned, and then only a few at a time, going over the house frequently, and always taking care to leave a sufficient quantity of berries, that when the bunch is ripe the berries may be closely wedged together, and the bunch quite stiff. Grapes that are produced on long rods are at all times more liable to shank off than bunches that are produced from spurs, which is owing to the loose habit of the bunches, and is still increased by injudicious thinning. In short, I never saw a bunch shank that the scissors had been kept from. I hope some of my brother-gardeners will try this system, and very seldom will their grapes be disfigured by shanking. — *Cotswoold, near Stroud, Nov. 16. 1840.*

If our correspondent will favour us with his address, we shall be much obliged. — *Cond.*

*Shanking and premature Shriveling of Grapes.* — Want of food appears to me to be the sole cause of the shanking and premature shriveling of grapes, about which so many conflicting opinions have been advanced in this Magazine. This deficiency of nutriment might arise from various causes, but, undoubtedly, the principal one is a bad border; under which head I include not only poor hungry soils that are incapable of supporting a plant in vigour, but those deep and narrow pits of rich earth in which vines are generally planted, and even borders of proper dimensions, if the subsoil is wet and the drainage imperfect.

Depend upon it, the most essential condition in vine culture is a dry border, by which term I would be understood to mean, a border so constructed as to insure a ready passage of superabundant moisture in the wettest seasons. The young fibrous roots of vines are exceedingly tender, and soon rot when soddened in cold wet soil; consequently the plant, being thus deprived of its mouths, may starve in the midst of plenty. According to the extent of the injury to the roots, so will the fruit suffer: thus, a partial destruction of rootlets will check the free swelling of the berries; the loss of a greater number of absorbents produces imperfect maturation of the fruit, shown by the absence of its natural colour and flavour; and a still greater amount of injury causes the pedicels to wither and the berries to shrivel. On the same principle (deficient nutrition), overcropping will produce the same result, even when the roots are in a healthy state. I have now under my charge a vineyard in which all the above-mentioned symptoms of debility are exhibited; and I know from examination that the vines have scarcely any fibrous roots, in consequence of deep planting in a deep border. The Muscat of Alexandria and the Frontignans suffer most, because the roots of those sorts are the most susceptible of injury from wet; the black Hamburg, being hardier, is less affected; while the white Muscadine, the hardiest of all, bears some very respectable fruit. I have lately destroyed the vines in a similar house, and made a new border on the plan recommended at page 378., and I shall be wofully disappointed if "shanking" is ever seen in this house. Let W. H. try that plan, raising the roots of his vines near to the surface of the border, and he will not find his soil "too rich." Let him also use the knife and scissors freely, and I will venture to warrant that he will have no more shanking in his grapes. — *J. B. W. Nov. 7. 1840.*

*Curling of Vine Leaves.* — Vine leaves flag when the moisture they transpire much exceeds that absorbed in the same time by the roots. This frequently occurs in the dry sunny days of spring, when the difference of temperature between the media surrounding the leaves and the roots may amount to 50° or more. If permitted to remain in that state of desiccation the leaves would most likely "curl," as described by Mr. W. Wilson; but by a little timely attention that injury might be prevented. When vine leaves flag, the atmosphere of the house should immediately be saturated with moisture, by swimming the floor, &c., with water; and a small-meshed net should be spread over the roof, to break the force of the sun's rays: this will generally restore the foliage to its usual freshness; but with weak vines, forced early, I have sometimes found it necessary to syringe the leaves in the middle of the day, and to shade with mats, and I never had a curled leaf. Let your Knightsbridge correspondent give his vines plenty to eat, and not roast them, and they will not curl up their noses at him. — *Idem.*

*The Curl in Vine Leaves.* *Gard. Mag.* for 1840, p. 568. — In answer to the complaint of your correspondent at Knightsbridge respecting the vine leaves in his grapery being curled, I would say that it is most probably owing to his growing green-house plants in his vine border. That should be left without anything to interfere with the roots of the vines, or to interrupt the action of the sun upon the earth. Dr. Lindley says "vines and mulberries cannot have too much manure;" therefore they will ill bear being robbed by the roots of other plants. I consulted two very experienced gardeners on the subject; one, who is particularly successful in the growth of grapes, said that the leaves of vines would be subject to the curl at this time (October) of the year. The other thought it might be owing to the red spider, which your correspondent can easily ascertain by consulting some one experienced in the care of vineries. I would add, I conceive the reason why some of the vines are affected and others not, is, that some are of a hardier sort than others. The Muscat of Alexandria and the grizzly Frontignan, are much more tender than the Muscadine or Sweetwater. — *S. Oct. 6. 1840.*



THE  
GARDENER'S MAGAZINE,  
FEBRUARY, 1841.

---

ORIGINAL COMMUNICATIONS.

ART. I. *Some Remarks on the Economising of Surfaces under Glass; the Introduction of artificial Heat to Fruit Borders; and the Attainment of Bottom as well as Surface Heat from the same Heating Apparatus.* Illustrated by Plans and Sections. By N. NIVEN, Esq., Landscape-Gardener and Garden Architect, &c.

EVERY superficial foot of surface under glass being, from its expensiveness and consequent value, of importance to the horticulturist, a few observations bearing on the economical appropriation of such surfaces may, to some of the readers of the *Gardener's Magazine*, be neither unwelcome nor uninteresting. Having for several years past been paying particular attention to the consideration of this subject, and being convinced, both from observation and experience, that many improvements may still be made in the internal arrangements of particular hot-houses, I now, with a view to this, submit to the discriminating and experienced editor of this work, the accompanying plans and sections; simply premising that they are those of a house lately erected near Dublin, under my immediate directions; and, so far as I can judge from a few months' working, it promises to realise my best expectations. Although it is well that each respective division of an extensive range of fruit-houses should be appropriated chiefly to some one particular purpose, as, for example, peaches, vines, &c., still I have long considered it desirable that some one at least of such houses should be so arranged as to be made more generally useful than is usual, as a fruit and forcing house throughout the year. Such a house I consider important, even to those who can afford to put up extensive ranges of hot-houses, but more especially to such persons as might not have it in their power to erect separate divisions for separate purposes. As briefly as possible, then, I proceed to explain the details of the plans and sections (*figs.* 13. to 17.) alluded to. The dimensions of the metal-roofed house delineated are, within walls, 60 ft. in length, by 14 ft. 6 in. in width, and 14 ft. 6 in. is the height of the back wall from the level of the floor within; thus obtaining with the semicurvilinear bar

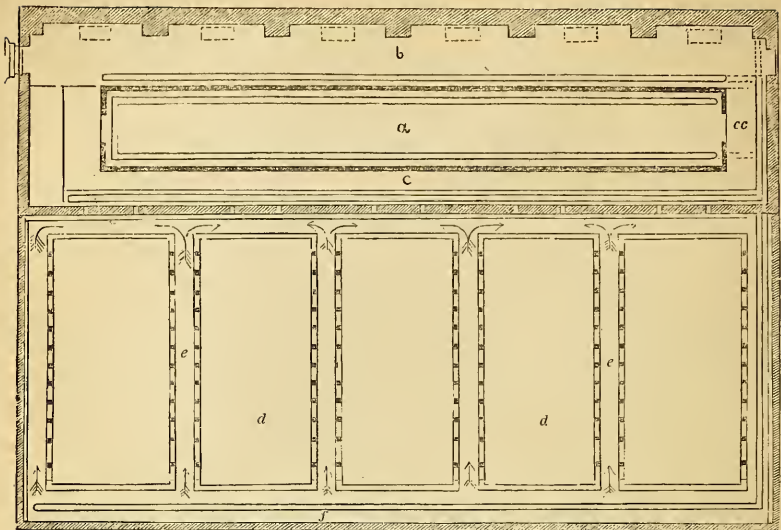

Fig. 13.

Ground Plan.

*a*, Fruiting pine-pit.  
with hot-water pipes.  
water pipe chamber.

*b*, Passage, with tubs in the recesses for Musas.  
*cc*, Cistern. *d d*, Vine border.

*c*, Front passage.  
*e e*, Air-flues. *f*, Hot-

an angle and curve of roof, in my opinion well adapted, not only for ventilation, but also for receiving a large portion of the influence of the sun's rays, both as regards light and heat. The following are the purposes for which this general fruit and forcing house has been arranged, namely: — the cultivation of the dwarf plantain, the granadilla, the guava, the cucumber or melon, the pine-apple, the vine; the forcing of early flowers, strawberries, &c. Each of the above-named objects of culture, I shall touch upon separately.

I. *The Chinese, or Dwarf, Plantain* (*Musa Cavendishii*). For the accommodation of this beautiful plant and desirable fruit, niches are provided in the back wall. The plants are grown in tubs, in rich sandy soil, and copiously supplied with liquid manure. Their progress in this situation, and with this treatment, has been rapid. Their rich foliage will soon form a canopy over head, without in the slightest degree interfering with any of the more useful portions of the house, and will add much to the beauty and richness within.

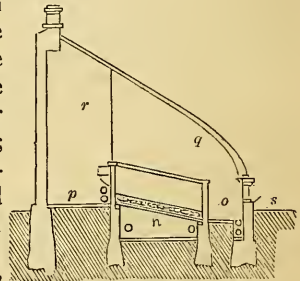

Fig. 14. Cross Section of the House.

*n*, Hot-air chamber. *o*, Front path, and hot-water pipes. *p*, Back path, hot-water pipes, with melon boxes over, and tubs for Musas. *q*, Trellis for vines. *r*, Posts on which the melons are trained. *s*, External front pathway.

Their progress in this situation, and with this treatment, has been rapid. Their rich foliage will soon form a canopy over head, without in the slightest degree interfering with any of the more useful portions of the house, and will add much to the beauty and richness within.

II. *The Granadilla* (*Passiflora quadrangularis*). This West Indian fruit, so beautiful in its flowers, as well as rich in its fruit, and therefore deserving of a place wherever room can be conveniently made for it, is trained from each end of the back wall over the arches, and partly down the piers, between the bananas.

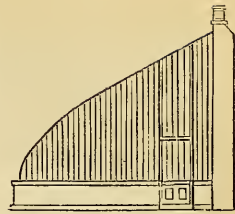

Fig. 15. End View.

III. *The Chinese Guava* (*Psidium Cattleianum*). This rich tropical evergreen, so much to be desired on account of its beauty, as well as of its luscious strawberry-flavoured and deep claret-coloured fruit, is planted in tubs, at each end of the house, where room has been provided for them. They are growing as standards, and are already showing flowers in rich abundance. It is hoped they will also prove an interesting and desirable addition to the dessert.

IV. *The Pine-apple*. For the purpose of starting, swelling, and ripening the fruit of this plant, a pit, as shown in the section, has been provided in the centre of the house, capable of containing four rows or so of good-sized plants, at a convenient and suitable distance for such from the glass; which pit, in consequence of the absence of cumbersome and shady front lights, as well as from being on a level with the wall plate from which the bars spring in front, has without any obstruction, as will be easily perceived, the full advantage of solar heat and light, as they may be required to promote the ripening and flavouring of the fruit grown in the pit. For the culture of the plants previously to this stage of their growth, a commodious, low, compact pit, according to Rogers's plan (which I very much approve of), has been provided; and, as far as the bottom and surface heat obtained from the pipes below is concerned, promises to work well.

The bottom heat in the pit of the house I am describing (as well as in that of Rogers's pit, which has been similarly arranged) is obtained in the steadiest and most regular manner. In effecting this desirable result, I have been at considerable pains. Taking into consideration the vexatious uncertainty and frequent disappointment arising from the old burning system, if I may so call it, of tan heat, along with its many inconveniences; also the more recent and important improvements through the medium of hot-water pipes in enclosed chambers beneath, particularly those where the surface is boarded over and perforated for the reception of the pots; and eminently successful, as, from what I have seen, this latter method promises to be, still I conceived that it was capable of material improvement, especially as regarded the medium in which the pots and roots were placed. It immediately suggested itself that a suitable

adjustment of the two principles above noticed, namely, the chamber mode of heating pits with boarded surfaces, and the mass-of-material mode of heating, as tan, dung, or leaves may be called, would probably be the best way of obtaining a steady, safe, economical, and genial temperature. With this view, a chamber was prepared beneath for the hot-water pipes, and cemented in the bottom, for the purpose of retaining, when it might be requisite, a thin sheet of water. This chamber is made sufficiently capacious to admit a man by a small door or hatch at either end, for the purpose of repairs and the application of water, or a thermometer, when required. It is roofed over with kyanised timber, 3 in. wide, by 2 in. thick, and 1 in. apart. Over this are laid about 8 in. of heat-absorbing materials, as brickbats and stones, the smallest on the top; next, a thin firm sod, with the grass side down; and, over all, about 2 ft. of half-decayed leaves. Thus, it will easily be conceived that this mass of materials will not only be capable of retaining the heat derived from the pipes below, but also be conducive to the promotion of the heat from the decomposition and slight natural fermentation of the shallow bed of nutritive vegetable matter, the medium for plunging in. On the first heating of the pipes, it took three or four days ere the pit attained its maximum temperature of  $100^{\circ}$ , when it was ready for the immediate reception of the plants, the heat being under complete control. It also turns out that instead of the constant application of the heat from the pipes within the chamber, that the same steady temperature can be kept up during summer, with only one night's application of their action during the week. The pipes are so arranged that either the pit or atmospheric heat of the house can be worked separately or together, as may be required. Another advantage attending these arrangements is, the having a magazine, as it were, of moist heated air, which, without materially deducting from the bottom heat above the chamber, retained by the materials alluded to, can on any emergency of severe weather be added to the surface heat of the house, by simply opening the two small doors at either end of the chamber. Moreover, it is found, that the heat is so regularly diffused over the surface-bed of the pit, that within 2 in. of the kerbs it is always in steady useful action. I calculate that the pots being plunged over the brims as they now are in this bed of leaves, the plants will thereby be allowed to root over it with much advantage to their fruit and suckers, and this too without the smallest risk; for, in fact, burning the roots, as it is called, can never happen; the maximum point of bottom heat being within the line of safety. Such a pit, for various purposes of plant-growing, will be found invaluable. Thus, all unseasonable moving of plants or materials is done away with, and a heat

produced that can be depended upon with certainty, as well as of the most simple and easy regulation. The pine plants fruited this season, in this house, were started some time previous to its being ready; they were chiefly Queens, and were, of necessity, started at only two years of age; which plants, notwithstanding their youth, have afforded a supply of fair-sized fruit for that variety, and, as has been admitted by all who have tasted it, of very superior flavour. I am convinced that, for this cloudy weeping country, the curvilinear metal roof is essentially important towards the proper maturation and flavouring of the pine-apple. With the view of getting into a stock of the larger sorts, and those best adapted for winter use, it is intended to introduce, chiefly, the Black Jamaica pine.

V. *The Cucumber or Melon.* Provision is made for the culture of these plants in boxes, as shown in the section, over the hot-water pipes, behind the pit. They are supported by metal brackets, and are placed at intervals, level with the back kerb, opposite each of the metal rods that strengthen the roof of the house; which rods are adapted for the training of the plants, and so form along this part of the house, opposite the bananas, columns covered with foliage and fruit of the most luxuriant description. In this way only the otherwise useless surface over the pipes is occupied. In the course of six weeks after sowing the seeds, cucumbers were cut, cultivated in this way, from 18 in. to 2 ft. in length; and a constant supply has ever since been kept up in succession to the present time, with a fair prospect of cucumbers throughout the winter. A summer crop of melons may also be obtained with equal ease in the same way, only observing that they and the cucumbers should never be grown in the same house at the same time.

VI. *The Vine.* Being thoroughly satisfied, as already hinted, of the comparative uselessness of front or upright sashes in the construction of the curvilinear roofs of fruit-houses; and taking into consideration, not only their inutility, but also the expense unnecessarily added thereby to such erections, apart altogether from the questionable nature of their effect as compared with the more substantial and neatly finished exterior of a well-proportioned parapet; I am induced for such purposes to adopt the latter, but more especially with the view of affording certain facilities, in connexion with the ventilators, towards the convenient introduction of the stems of the vines into, or out of, the house. At each side of each ventilator, it will be observed that there is an opening for the reception of each vine; which vine is planted, not close to the front parapet as usual, but 4 ft. or so from the house, and then taken on to it under a front pathway, in narrow boxes which are made with lids and open at the ends, and through the opening under the ventilator, to

the trellis within. This is done for the purpose of preserving the stem from external exposure; and also for obtaining a radius or sweep of 4 ft., when the vines are to be taken in or out of the house, besides having the width of the ventilator itself, which is other 4 ft.; and thus, if possible, avoiding the injurious effects that so frequently arise from twisting, in consequence of the circumscribed means of ingress and egress generally afforded. For the purpose of obtaining a succession of grapes in the same house, it is proposed to introduce only one half of the vines at a time, say about one month or so before the other half. The vines will be trained in single spurred rods from the bottom to the top of the house, at intervals of every 5 ft., having a run of upwards of 20 ft. Length of bar, rafter, or trellis, I consider of the highest importance in the training of the vine. Thus, again, at a season of the year when the pines require a partial shade, the vines so trained will effect this.

With respect to the preparation of the vine border, of which a plan (*fig. 13.*) and sections (*figs. 16. and 17.*) are also given, I conceive, in connexion with

this, that a much more interesting subject than any of those I have as yet touched upon, remains for consideration, namely, the application of artificial heat from

the same heating apparatus that supplies bottom and surface heat to the house within. Considering the many facts bearing on the importance of obtaining for exotic or forced fruits a suitable proportion of terrestrial temperature, according with what nature has

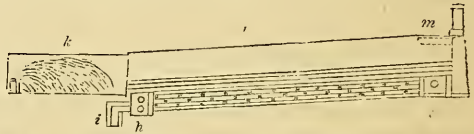

Fig. 16. Cross Section of the Border, Pathway before the front Wall, and Walk at the Extremity of the Border.

*g*, Air chamber. *h*, Hot-water pipe chamber. *i*, Drain.  
*k*, Walk in front of the border. *l*, Border. *m*, Pathway, with wooden tubes under it for the stems of the vines.

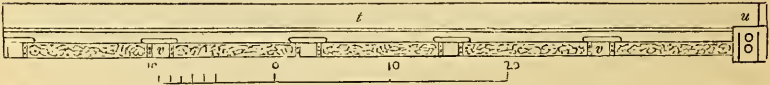

Fig. 17. Longitudinal Section of the Vine Border.

*t*, Prepared soil on the prepared bottom. *u*, Hot-water pipe chamber. *v v*, Air-drains.

provided for such in their native countries; and also the many evidences bearing on the necessity for some material change in this respect, especially as regards early forced fruits; likewise the many bad consequences arising from deep planting, deep borders, and cold retentive subsoils; I say, with such circumstances as these before me, I feel myself called upon unhesitatingly to submit what I may venture to hope will be found a material improvement in horticultural science. That the ripening of the wood,

and the colouring and flavouring of the fruit, very much depend upon the position of the roots, both as it regards heat and air, as well as suitability of soil, there can be little doubt, for this has been already well ascertained; therefore, I feel it superfluous to enlarge upon the principles upon which a different practice is based. Every day's experience, as well as occasional experiment, must point out equally to the scientific and practical man, that some change in the relative temperature necessarily existing in such countries as these, between the roots and branches of trees put into a state of premature excitement by forcing, is very desirable. With this object in view, I propose heating the border alluded to through the means of hot-water pipes, as will at once be understood by referring to the plan and sections, *figs. 13. to 17., p. 50. to 54.* The chamber containing the pipes is formed along the one end and front only of the vine border, having small minor chambers or drains, 1 ft. square, crossing it at regular distances, with open side walls which may be covered over, either with short pieces of charred timber, long-shaped bricks, or large slates; the spaces between these minor air-conducting chambers to be filled up with broken stones or brickbats. The whole is to be covered over with a stratum of limestone broken very small, and then by a firm thick sod with the grass side down, over which the compost is to be laid, to the depth of  $2\frac{1}{2}$  ft. next the house, and about 2 ft. at the walk or chamber. Thus, whenever the branches of the vines are introduced inside the house, the valves may be turned on the outside pipes, and the requisite temperature obtained for the roots. Calculating according to the ordinary principles of circulation, I conceive that a regular current through the minor chambers will be the result of heating the air in the pipe chamber in front; and also that the heat will find ready access through the open side walls of the cross chambers, amongst the stones or brickbats forming the bottom of the border between. At the same time I purpose having a small plug-hole opening opposite the end of each minor chamber, through the front parapet, into the house; so that at any time, if found requisite, the heat derived from the outside chambers (which may be expected to be very moderate) may be admitted into the body of the house. Any necessity for this, however, is not at all likely, as with the existing means of heating the house described, we find we have an ample supply for all the purposes intended. This application of heat to the roots may easily be regulated by having a thermometer hung in a box in the border. I would also suggest that a slight covering of rotten dung or leaves will be requisite over the surface, for the purpose of retaining the heat, as well as protecting the roots and stems that may be near

it, at least until the severe weather of winter and spring is past. The expense of these arrangements will not be much more than that of the pipes; as, under any circumstances of a well-formed border, the drains must necessarily be made.

Besides the application of the above principle to vine borders, I am not sure whether it may not yet be found an important auxiliary in the cultivation of the peach, nectarine, apricot, and even pear, against walls, in cold northerly parts of the country; for I am disposed to think that the ripening of the wood, and the production of flower or fruit buds, depend much more upon the management of the root, as regards temperature, than we have been in the habit of conceiving.

VII. *Forcing Strawberries.* A front shelf, level with the bottom of the wall plate above the ventilators, and over the front pipes, is intended for the forcing of early strawberries. Light and air being so essential towards their successful growth, in this situation they will have an ample supply of both.

VIII. *Forcing Shrubs.* The front and back kerbs of the pine pit will afford space for lines of roses, kalmias, rhododendrons, &c., to be brought in early, either for the greenhouse or drawing-room.

To conclude: I offer a few words upon ventilation, in connexion with metal houses; also my opinion as to the comparative merits of metal and wood, in the construction of hothouses. I conceive, from most I have seen in the way of metal houses, that they have suffered much, in point of character, from the want of sufficient means of ventilation; bearing in mind the greatly increased medium for the reception of the solar rays, by the curvilinear form of roof, as well as its much increased surface for light, compared with the oblique roof of the wooden house with its heavy shadowy rafters. Taking, I say, these circumstances into consideration, I am only surprised that the damage arising from a defective means of ventilation has not been even greater than what I have witnessed. This, however, is not the fault, it has merely been the misfortune, of the metal house. By the introduction of the semicurvilinear bar, a facility is afforded for ample ventilation, by means of square sliding sashes in the upper part of the roof, which is made straight on purpose.

Comparing metallic houses with wooden ones, in point of adaptation for this country and general elegance, I decidedly prefer the former; but where economy becomes any material consideration, then I would say adopt the wooden house. With respect to heating, in either case let it be by hot water.

I consider it due to the parties who executed the work of the house described, and who are now extensively engaged in similar erections in other parts of Ireland, to state, that they have not



only executed their work reasonably and well, but have always exhibited the most anxious desire to finish it in the best manner. The parties I allude to are Messrs. Turner and Walker, of the Hammersmith Works, near Ball's Bridge, Dublin. The one executes the metal work of the house, and the other the hot-water apparatus.

*Richmond Hill, Kingstown, Dublin, Dec. 1840.*

ART. II. *Mr. Glendinning's Opinion of Mr. Corbett's Mode of Heating by Hot Water.* By R. GLENDINNING.

MR. CORBETT'S discovery of circulating hot water in open gutters, and its application to horticultural purposes, is the most important invention in heating every description of forcing and plant structure, since the first attempt of communicating heat to plants by means of warm water. Mr. Corbett's plan combines the simplicity of the good old level system with the grand advantage of diffusing through the house, without trouble, any quantity of moisture required, or entirely withholding it. The circulation of the water in the gutters is quite as rapid as by any other system, if not more so, even when left entirely open. The invention is divested of all intricacy, as the water may be exposed to full view from its leaving the boiler until its return, and consequently never liable to go out of repair. Its effectual application to every description of forcing-house is at present without a parallel; as, by the partial or entire removal of any number of covers, an unvarying degree of moisture, always governed by the temperature maintained, can, with the greatest ease and accuracy, be communicated. This alone, to practical men, will secure to it a decided preference. Red spiders, thrips, and all other insects, will be readily subdued; and an atmosphere, at once invigorating and refreshing, at all times maintained. During the late very severe weather, when the thermometer was at 10°, it has proved to us its great

- a, Back path.
- b, Bark pit, 50 ft. long in the clear.
- c, Exterior pit for dung casing, to revive the heat.
- d d, Gratings to drains.
- e, Stink-trap to drain.

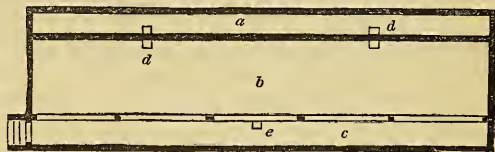

Fig. 18. *Ground Plan of a Pit to be heated in Mr. Corbett's manner.*

superiority most satisfactorily. It is erected in a geranium-house in our nursery; and, by careful comparison with a number of other modes of heating, our opinion of its excellence is very strongly confirmed. It has also been thoroughly tested in a pine-pit erected by us for a lady in this neighbourhood, similar

- ff*, Glass roof.  
*g*, Bark pit.  
*h*, Back path.  
*i*, Pit for dung casing.  
*k*, Drain.  
*l*, Hinged cover of ledged boards, to protect the dung from the rain and wind.  
*m*, Ground line.  
*n*, Suspended shelf for strawberry pots.  
*o*, Slate shelf for pots.  
*p*, Stink-trap communicating with the cross drain (*q*), which leads to the main or barrel-built drain (*k*).  
*r*, Corbett's hot-water apparatus.  
*s*, Hollow wall of bricks on edge.

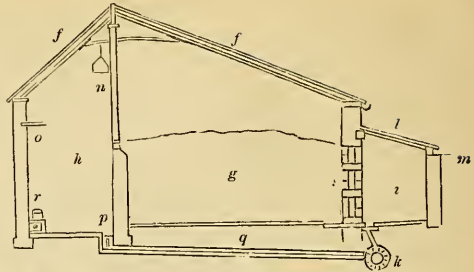

Fig. 19. Cross Section of a Pit to be heated according to Mr. Corbett's System.

to the plan (*figs.* 18. and 19.) I now send you, which is designed for the approval of His Grace the Duke of Somerset.

We can safely recommend this system of Mr. Corbett's as the best that has come under our observation; and we speak advisedly, having had a great deal to do with various systems of hot water under their worst and best forms. In grape, peach, and pine forcing, and in stoves appropriated to the culture of orchidaceous plants, it ranks above, and must ultimately supersede, all other systems. Mr. Corbett, by his invention, has done much to advance horticulture, and conferred a great boon on his brother gardeners, deserving their best thanks, together with the patronage of their employers.

*Exeter Nursery, Jan. 10. 1841.*

A MOMENT'S reflection will convince our readers that the above mode of heating does not at all interfere with Mr. Penn's system of ventilating; for the open gutters of hot-water, if placed in Mr. Penn's hot-air chamber instead of his pipes, or in part as a substitute for them, would doubtless saturate the air to be circulated better than the water at the bottom of the cross-drain. We formed an unfavourable opinion of Mr. Corbett's mode of heating when it was first announced, as will appear by our Volume for 1838, p. 527.; and this was partly from an idea that Mr. Corbett claimed too much for it. Having heard Mr. Glendinning's opinion on the subject, we have lost no time in publishing it, with a view to doing Mr. Corbett justice; and we hope that his system will soon take that high degree of rank among other systems to which it seems so well entitled. —  
*Cond.*

### ART. III. On the *Cytisus Adami*, or Purple Laburnum.

By M. POITEAU.

I RECEIVED your valuable letter, and it is with much pride and satisfaction that I find you have applied to me rather than to any one else for the information you desired respecting the *Cytisus Adami*.

Here follows a list of the articles in which the *Cýtismus Adàmi* is treated of in our *Annals*.

1. Note on a new *Cýtismus*, by M. Prevost, vol. vii. p. 93.
2. Note on this note, at the end of the same article, by Poiteau, p. 95.
3. Physiological notice on the *Cýtismus Adàmi*, by Poiteau, vol. x. p. 11.
4. New observations on the *Cýtismus Adàmi*, by M. Camuzet, vol. xiii. p. 196.
5. Considerations on vegetable tissue, with respect to the orange called the Bizzarrie, by M. O. Leclerc, vol. xviii. p. 302.
6. New observations on the *Cýtismus Adàmi*, by Poiteau, vol. xviii. p. 6.

The *Cýtismus Adàmi* has smooth leaves and branches like the *Cýtismus alpinus*, which we call the sweet-scented cytismus, but the flowers are buff (chamois), not so large, and less regular than those of either. Sometimes the *C. Adàmi* produces flowers half reddish yellow; sometimes one of its buds produces a true branch of *C. Labúrnum*, with pubescent leaves, and long bunches of yellow flowers exactly like the species, and seems inclined to return to its type. Hitherto nothing has prevented our considering *C. Adàmi* to be a hybrid of *C. Labúrnum*, of which the father is not known; but here is a difficulty which puzzles us. This same *C. Adàmi* produces also, besides one or more branches of *C. Labúrnum*, branches of *Cýtismus purpùreus*, which remain small and slender, the leaves of which are small and smooth, and the flowers, instead of being in long pendulous bunches, are in pairs (*geminées*) and axillary, as in their natural type or natural species, only the flowers are rather larger than in their type, but they have their violet purple colour. Observe, that these branches of *C. Labúrnum* and of *C. purpùreus* never proceed from casual buds (*bourgeons adventifs*), but from eyes naturally predisposed on the branches of *C. Adàmi*. It has happened three or four times, that, in a graft which had only two eyes, one has produced *C. Adàmi*, and the other *C. purpùreus*.

There is now to be seen at M. Bertin's, nurseryman at Versailles, a cytismus which has these three species at once on the same root. To explain this phenomenon, we must suppose that the elements of three species circulate separately under the bark of *Cýtismus Adàmi*, and that each of them bursts forth at different places; and that the elements of *Cýtismus Labúrnum* bursting forth oftener than the elements of *Cýtismus purpùreus*, they must be either more active or more abundant. This being admitted, it may be asked how these three elements are united under the

bark of the *Cytisus Adami*. To this we may reply, that the seed which produced this tree had been fecundated by the pollen of a cytisis or other tree not yet ascertained, and by the pollen of the *Cytisus purpureus*; this is supposing that the female in plants can be fecundated by several males at the same time. If this supposition is admitted in certain animals, there is no example that it is admitted in vegetables; for I consider all that M. Galesio has said on superfœtations as not proved. I I knew M. Galesio personally; he was an amateur who had no rational idea of vegetable physiology, and who gave as verified facts what was only the fruit of his imagination.

Now that it is a received opinion that the embryo pre-exists before fecundation (the embryo must be considered as the developement, by fecundation, of a germ situated at the extremity of one of the lateral fibres of the capillary leaf) in vegetables as in animals, and that it is acknowledged that the sexes are determined in the embryo before fecundation, it is difficult to admit that the three species enclosed without mingling under the bark of the *Cytisus Adami* are produced by the simple fact of vegetation, the action of which is admitted only to give life to the pre-existing embryo.

In ordinary hybrids, the influence of the male and female is nearly equal on the embryo, and the plant produced partakes of the character of two plants: but in the *Cytisus Adami* there is little or no mixture; each of the three species shows itself distinct, sometimes in one place, sometimes in another, without its being previously foreseen.

If we could still say with Buffon, that the embryo is formed in the act of fecundation, by the mixture of the seminal liquid of the male and of the female, the explanation of the origin of *C. Adami* would be easy; but the preexistence of the embryo to fecundation being admitted, the opinion of Buffon is no longer valid. We must, therefore, say of the *C. Adami* what has been said of the orange called Bizarrerie, namely, that in the act of fecundation the fructifying substances have not mingled completely; that some particles have remained untouched; that they have lived and vegetated of themselves in the embryo and in the seed; that they continue to vegetate in the body of the tree always of themselves; and that, when opportunity again presents itself, they produce a bud, branch, leaf, and flower of their own species.

This, my dear Sir, is the *ne plus ultra* of the hypothesis which we have founded here on the Bizarrerie and on the *Cytisus Adami*. I hope you will do better than we have done.

On the 20th of this month, M. Jaques again presented to the Society of Horticulture a branch of *Cytisus Adami*, which had

on one side a shoot of its own species bearing flowers and glabrous leaves, and on the other a pubescent shoot with pubescent leaves, and the yellow flowers of *C. Labúrnum*. M. Jaques said that a more scientific person than himself had discovered in the tissue of this tree three different sorts of molecules, which are the sources of the three species which exist under its bark, and which burst forth under certain circumstances. We expect to be shown the three different molecules.

If you wish to know the history of the Bizarrerie, see *L'His-toire Natural des Oranges*, by Messrs. Risso and Poiteau, published in 1818, p. 17. 107.

Paris, May 28. 1840.

---

ART. IV. *Botanical, Floricultural, and Arboricultural Notices of the Kinds of Plants newly introduced into British Gardens and Plantations, or which have been originated in them; together with additional Information respecting Plants (whether old or new) already in Cultivation: the whole intended to serve as a perpetual Supplement to the "Encyclopædia of Plants," the "Hortus Britannicus," the "Hortus Lignosus," and the "Arboretum et Fruticetum Britannicum."*

*Curtis's Botanical Magazine*; in monthly numbers, each containing seven plates; 3s. 6d. coloured, 3s. plain. Edited by Sir William Jackson Hooker, LL.D., &c., Professor of Botany in the University of Glasgow.

*Edwards's Botanical Register*; in monthly numbers, new series, each containing six plates; 3s. 6d. coloured, 3s. plain. Edited by Dr. Lindley, Professor of Botany in the University College, London.

*Paxton's Magazine of Botany, and Register of Flowering Plants*; in monthly numbers; large 8vo; 2s. 6d. each.

*The Ladies' Magazine of Gardening*; in monthly numbers; 8vo, with coloured plates; 1s. 6d. each. Edited by Mrs. Loudon.

Malvæcæ

2004. MA'LVÀ lateritia Hook. brick-coloured  $\frac{3}{4}$   $\Delta$  pr  $\frac{1}{2}$  s R Buenos Ayres 1840. D co. Bot. mag. 3846.

A pretty plant, with prostrate stems, and pale red flowers. It is a native of Buenos Ayres, and will grow freely in the open border. (*Bot. Mag.*, Jan.)

Balsamîncæ.

+ *Impatiens rosea* Lindl. Another Indian species of *Impatiens*. "It is loaded with delicate pale rose-coloured flowers, which are arranged along the stem; and, when gathered and placed in water in a sitting-room, it will continue to expand them for four or five weeks successively." (*B. M. R.*, No. 22, Jan.)

Tropæolæcæ.

TROPÆ'OLUM Moritzianum Klotzsch Mr. Moritz's  $\Delta$  or 6 jl Y.R. Cumana 1839. S co. Bot. mag. [3844.

This pretty Tropæ'olum has the petals, or inner segments of the perianth, curiously fringed with red; the whole of the flower, though of a bright golden yellow, is also stained with red. Seeds received from Cumana, in the West Indies, soon vegetated and flowered in the greenhouse of the Glasgow Garden,

while others in the open ground grew more vigorously, but did not flower. (*Bot. Mag.*, Jan.)

*Leguminosæ.*

*Clánthus córneus* Lindl. (*Streblorhiza speciosa* Endl.) A very handsome plant, which will probably prove "a very good conservatory creeper." (*B. M. R.*, No. 9., Jan.)

*Acacia platýptera* Lindl. A greenhouse plant from the Swan River. Both these plants have flowered in Messrs. Lucombe, Pince, and Co.'s nursery at Exeter. (*B. M. R.*, No. 10., Jan.)

*Rosacæ.*

1515. *SPIRÆA*  
*kamtchática* Dec. var. *himalénsis* Lindl. Himalayas  $\frac{1}{2}$   $\Delta$  or 2 jn jl W India 1838. D [co. Bot. reg. 1841, 4. Bot. reg.]

A very pretty kind of perennial *Spiræa*, which is quite hardy in British gardens, but which, like the other common kinds, "flowers best when planted in a rather damp situation, and partially screened from the rays of the sun." (*Bot. Reg.*, Jan.)

*Crassulacæ.*

3356. *ECHVE'RIA*  
*lurida* Lindl. lurid  $\Delta$  or  $\frac{1}{2}$  jn S Mexico 1840. D [reg. 1841, 1. Bot. l.p.s.]

*Goodeniviæ.*

616. *EUTHALES*  
*macrophýlla* Lindl. large-ld  $\frac{1}{2}$   $\Delta$  or 4 su Y.Br Port Augusta 1839. D co. [1841, 3. Bot. reg.]

A very handsome greenhouse perennial, sent home from Port Augusta, in New South Wales, by Mrs. Molley. It is a very showy plant, with bright yellow and brown flowers, which are produced in succession throughout the whole summer and autumn. It grows in any rich free soil, and strikes freely from cuttings. (*Bot. Reg.*, Jan.)

*Gesneriæcæ.*

1702. *GLOXINIA*  
*rùbra* Part. red  $\frac{1}{2}$   $\square$  or 1 s S Rio Janeiro 1840. D s.p. [p. 271. Part. mag. of bot. vol. vii.]

A very beautiful species, with rich scarlet flowers. It is in the Epsom Nursery, and at Mr. Lowe's at Clapton. "It is propagated by planting the leaves in sand, and placing the pots containing them in a humid temperature. The leaves, likewise, if carefully fastened flatly on moist sand, and shaded from solar influence, will sometimes protrude roots, and form young plants, from many parts of the midrib." (*Part. Mag. of Bot.*, Jan.)

*Pedalineæ.*

1720. *MARTYNIA*  
*fràgrans* Lindl. fragrant  $\square$  or 1 jn C Mexico 1840. S r.m. Bot. reg. 1841, 6.

This very beautiful plant has been already mentioned in our preceding Number (p. 13.); and, unlike all the other species of the genus, it is fragrant. It should be grown in light rich soil. (*Bot. Reg.*, January.)

*Convolvulacæ.*

*Ipomœa batatoides* Benth. This is said to be the true jalap plant. There are only two plants in the Horticultural Society's Garden, and it has hitherto been found impossible to propagate them. They have large, fleshy, oblong tubers, and dark crimson flowers. (*B. R. M.*, No. 23., January.)

*Scrophularineæ.*

- \* *PAULO'WNIA* Sieb. (In honour of the name of the Hereditary Princess of the Netherlands, who [was daughter to the Emperor of Russia.]  
*imperialis* Sieb. imperial  $\frac{1}{2}$  or 30 ap L Japan 1840. C co. Ladies' Mag. of Gard., t. 1.

This very beautiful tree, having proved quite hardy in the Jardin des Plantes in Paris, will be a great addition to our shrubberies and ornamental plantations. It will grow in any common garden soil, but it thrives best in one that is dry, and somewhat loamy. (*Ladies' Mag. of Gard.*, January.)

1807. *ANGELO'NIA*  
*cornigera* Hook. horn-bearing  $\square$  pr 1 au P Brazil 1839. S co. Bot. mag. 3848.  
*Synonyme*: *A. ciliata* Gardner.

A pretty stove annual from Brazil. The flowers are rather small, but

“extremely rich in colour, and a beautiful object for a microscope.” It was found in 1839 by Mr. Gardner, who called it *A. ciliata*, but this has been changed by Sir W. J. Hooker to *A. cornigera*, a name suggested by the “horn-like appendage” to the lower lip. (*Bot. Mag.*, January.)

*Thymelææ.*

*Pimelæa spectabilis* Lindl. A very handsome plant, with “large heads of pink flowers, collected within broad floral leaves, richly stained and bordered with crimson.” (*B. M. R.*, No. 18., January.)

*Orchidæææ.*

2540. *ONCIDIUM*  
*macranthèrum* Hook. large-anthered  $\text{£} \square$  cu  $\frac{1}{4}$  ap G.P Mexico 1840. O [mag. 3845.  
r.w.p Bot.

A little insignificant plant, with a very few small pale flowers. (*Bot. Mag.*, January.)

2546. *GONGO'RA*  
*bufonia* Lindl. toad-skinned  $\text{£} \square$  or 1 my Var. Brazil 1838. O r.w.p Bot. reg. 1841, 2.

A handsome species of *Gongora*, from the lightness and shape of its flowers, though their colour is a dingy yellow, variegated with purple, green, and brown. (*Bot. Reg.*, January.)

*G. fulva* var. *vitellina* Lindl. A very pretty plant, “with bright yellow flowers, less spotted than usual;” a native of Mexico. (*B. M. R.*, No. 4., Jan.)

2530. *CATASE'TUM.*

A plate is given in the *Bot. Reg.* (t. 5.), containing detached single flowers of the following five species and varieties of this genus: — *C. callòsum*, *cornutum*, *barbatum* var. *proboscideum*, *laminatum* var. *eburneum*, and *lanciferum*.

*Pleurothallis recurva* Lindl. A creeping plant, with dull purple flowers. (*B. M. R.*, No. 1., January.)

*P. lutèola* Lindl. With small yellow flowers. (*Ibid.*, No. 2.)

*Aporum sinuatum* Lindl. From Sincapore, with pale yellowish green flowers. (*Ibid.*, No. 3.)

*Arundina bambusæfolia* Lindl. An Indian epiphyte, “with the foliage and habit of a small bamboo, and the flowers of a *Cattleya*.” It has flowered at Messrs. Loddiges's. (*B. M. R.*, No. 5., January.)

ART. V. *On the Culture of the Peach in the open Air.* By ROBERT GLENDINNING.\*

THE peach belongs to the natural order *Rosæææ*, and is the *Pérsica vulgàris* of botanists: it is a native of Persia, and was first brought into Europe by the Romans, in the time of the Emperor Claudius, and introduced into this country about three centuries ago, although by some thought to have been brought over during the Roman invasion, which is not improbable. The tree is known to abound with hydrocyanic or prussic acid, and hence probably the injury resulting from eating the fruit previously to the full development of the saccharine juice. The fruit in a perfectly ripened state is highly and justly esteemed, and when divested of its skin is one of the most wholesome brought to table, and peculiarly calculated for invalids.

The climate of Devon is eminently favourable for the growth of the peach in the open air: the following observations will

\* Under the cuts in p. 68, 69. for “*Errington*,” read “*Glendinning*.”

therefore apply to that mode of culture. It is almost useless to state that the nectarine is a mere variety of the peach, and the treatment suitable to the one is equally so to the other.

The preparation of the border, and the proper soil to secure healthy and fruitful trees, form a fundamental part of our enquiry; it is the groundwork of the whole. So much in truth depends upon a border prepared upon sound principles, that, unless this is done, it will be impossible to produce healthy, well-ripened, and fruitful wood. Borders, to be attended with such a result, can only be properly formed by gardeners who possess a physiological knowledge of the peach tree. As the branches are subjected to artificial regulation, it becomes equally important to place the roots under similar control, and to obviate as much as possible the absorption of ingredients placed beyond the reach of atmospheric influence. It never can be too often insisted upon, nor too well understood, that noxious juices are always found in a more fluid state, and in that condition much more readily imbibed, than nutritious juices; and that these crude ingredients are found in far greater quantities at a considerable distance from the surface, beyond the reach of atmospheric action, which alone can decompose the carbonic acid, and assimilate the proper juice; bearing in mind, also, that the absorption of liquids depends upon their degrees of fluidity, and that impure and imperfectly converted juice is always found in that state, and the further it is removed from solar influence, so is its degree of fluidity, and hence also its perniciousness. How often do we hear complaints of failure? And the mystery under which these are enveloped is the vigorous state of the trees, which are annually producing immense quantities of redundant shoots, requiring the saw to remove them. We hear the cause attributed to a bad season, or a bad situation, while in truth it is a radically bad border, equally badly managed. This annual dislodgement of so much wood, produced in consequence of such an abundant supply of impure food, placed out of the reach of the action of the atmosphere, and thus freely absorbed by the spongelets, renders pruning unavoidable and extensive, so that sound cicatrization is rarely effected. Gum will therefore be found exuding in all directions: this is caused by so much lopping becoming necessary to keep the tree within bounds. The excreting of gum is a sure sign of the absorption and imperfect elaboration of an undue portion of noxious fluids. The sap thus extravasated frequently accumulates under a degree of compression in the old branches of the tree; it will therefore be found excreting as the temperature increases, and accumulating in impenetrable masses, completely preventing the ascent and descent of the sap, and ultimately producing death wherever these indurated lumps form.



Having, I trust, clearly and satisfactorily pointed out the cause of failure, as regards the absorption of impure and pernicious fluids by the spongioles, the next point to be considered will be the formation of borders upon a right principle, completely obviating the possibility of such fatal consequences.

When new gardens are forming in low and damp situations, particularly with a retentive subsoil, I should always insist on keeping the walls well out of the ground, by raising the foundation to where the set-off takes place considerably above the surface level; by so doing there is secured to the border a much greater inclination than is usual, or would be desirable under more favourable circumstances. The oblique tendency thus secured will assist in carrying off the redundant precipitations, whether natural or artificial, to the front of the border. It will be absolutely indispensable, in such situations, to provide gutters along the edges of the walks to receive this surface water, as well as drains under for carrying off this and all other superabundant moisture. A moderated supply of water, to produce and retain in the soil in which the trees are planted a medium temperament, should be a paramount object in the original formation of the border, that a controlled supply of properly converted food may be promoted and secured. It will be desirable to have borders from 10 ft. to 18 ft. wide, and bearing some proportion to the height of the wall; and walls from 10 ft. to 14 ft. high will be found in every respect suitable for the peach tree. The height of the walls also should bear some proportion to the space enclosed, as a small piece of ground surrounded with a high wall will be just as objectionable as a large area enclosed with a low wall. The border should be excavated 2 ft. 6 in. or 3 ft. deep, giving a similar inclination to the bottom, as has already been described for the surface: this measurement should be taken from where it is intended to finish with the proper soil, that is, 6 in. above the set-off. I should then recommend a good drain to be formed in front of the border and parallel with the wall; the top of this drain should be level with the bottom surface that it may receive all the surplus water, whether arising naturally, or that which may percolate through the soil; I would then place 1 ft. of loose rough rubble over the entire bottom of the border. The material used for this purpose should be such as would secure the most perfect drainage; over this place a few inches of furze, ferns, or any description of light brushwood, to prevent the soil mixing with the drainage. In some situations much of this preparation will be unnecessary: but it should be attended to under every modification of circumstances. The facts which I have detailed, founded as they are upon a physiological investigation of the subject, clearly elucidate the course to pursue, and how utterly fruitless it is to

expect any other than mere chance success, when based upon nothing besides empirical skill.

The soil most suitable in my opinion for a peach tree border is, sound maiden loam of a medium texture, taken from old pasture land, cut 2 or 3 inches thick, and piled in heaps for a few months, when it may be chopped vertically with the spade and put into the border. Allowance should be made for the soil settling down: it must therefore be kept at least 6 in. above the intended level; this will be preferable to filling in the border what it may sink after the trees are planted, because this would bury the roots as well as the stem of the tree, and would be nearly as fatal an error as planting on an unprepared border. It may appear rather questionable, because contrary to the general practice, to employ nothing more than this pure and primitive loam, in no way enriched; but borders containing soil richly and liberally manured, more especially in low and wet situations, hold an overabundant supply of moisture, which does not escape either by percolation or transpiration: hence the presentation of immense quantities of impure and crude fluids, producing all those baneful effects already described. Under every variety of circumstance, therefore, it is important to avoid the mixing of any kind of manure whatever with the soil which I have here recommended, and would urge to be used in every situation where the peach is cultivated for its fruit. A border formed upon the principle which I have endeavoured to describe, and the specified kind of soil, will secure the most happy results. Extraordinary annual quantities of wood will never be produced; therefore, severe pruning will be obviated, the age of the tree very much extended, and its fruitfulness most effectually sustained.

The following select list of peaches and nectarines are the best sorts in cultivation, and may be relied upon as excellent, if procured true to their names. To assist in their identification, I have appended the forms of the leaves and flowers, as given by Mr. Thompson of the London Horticultural Society, who is by far the best pomologist in modern times. Having proved the whole in the following list, I speak with some confidence as to their merits; I have placed them in their order of ripening. Those marked with an asterisk are indispensable in a small collection.

#### NECTARINES.

| Names.            | Leaves.                  | Flowers. |
|-------------------|--------------------------|----------|
| Hunt's Tawny      | serrated, without glands | small.   |
| * Downton         | reniform glands          | small.   |
| * Elruge          | reniform glands          | small.   |
| Brugnon           | reniform glands          | small.   |
| * Violette Hâtive | reniform glands          | small.   |
| Murry             | reniform glands          | small.   |
| Pitmaston Orange  | globose glands           | large.   |
| New white         | reniform glands          | large.   |

PEACHES.

| Names.                     |     | Leaves.                  |     | Flowers. |
|----------------------------|-----|--------------------------|-----|----------|
| * Grosse Mignonne          | -   | globose glands           | - - | large.   |
| * Red Magdalen (of Miller) |     | serrated, without glands |     | large.   |
| Spring Grove               | - - | globose glands           | - - | large.   |
| * Royal George             | - - | serrated, without glands |     | small.   |
| * Noblesse                 | - - | serrated, without glands |     | large.   |
| Malta                      | - - | serrated, without glands |     | large.   |
| George the Fourth          | -   | globose glands           | - - | small.   |
| * Royal Charlotte          |     | serrated, without glands |     | small.   |
| Bellegarde                 | - - | globose glands           | - - | small.   |
| Barrington                 | - - | globose glands           | - - | large.   |
| Chancellor                 | - - | reniform glands          | - - | small.   |
| * Late Admirable           | - - | globose glands           | - - | small.   |
| Nivette                    | - - | globose glands           | - - | small.   |
| Morrisania Pound           | -   | globose glands           | - - | small.   |

The above collection contains nothing but freestone peaches and nectarines; unhappily there exists a division of opinion as to whether clingstones should be entirely rejected: for my own part I have long since made up my mind never to plant a clingstone, considering the extensive assortment of first-rate kinds of melters from which we have to choose.

The time I would recommend to plant the peach tree, in preference to any other, would be the end of October and beginning of November, because the sap is not then wholly inactive. They may, however, be planted with considerable success, from that time until the end of February. Select trees the third season after budding which have been carefully trained in the nursery: those that have produced the shoots of equal and moderate strength should be preferred: there is nothing so desirable as seeing a tree go the right way at first; therefore, this is a point worth attention. In planting, never dig a pit, but lay the roots carefully on the surface of the border, and cover them not deeper than 3 in. It is advisable, after planting, to cover the hill with a little loose litter, to protect the roots from drying winds. The distances between the trees will depend upon the height of the wall and the width of the border; the space between them will therefore vary from 14 ft. to 20 ft. Should any of the trees, after having been planted two or three years, be growing more vigorously than is desired, I would recommend their being taken up and replanted; great caution will be requisite in this operation to preserve uninjured all their fibres: a three-pronged fork must be used, and every precaution maintained throughout the performance. When the tree is completely out of the ground, level in the soil and gently tread it, keeping it rather above than under the original level of the border; the tree will then be planted completely on the surface, and covered as in the former instance: this should be done in October, so that the soil should be properly consolidated before

the pruning and nailing season arrives; otherwise the plant will hang by the shreds as the soil settles down, and expose the roots, to the manifest injury of the tree. This is a point worth attention in all new-planted trees, especially if in an entirely new-formed border.

Much has been written on training the peach tree, and every scientific cultivator has his favourite system. The kitchen-garden at Bicton, which I originally planned and planted about nine years ago, contains a greater number of fine specimens of training, than I have ever witnessed in any one garden; therefore, to detail the manner of training so successfully pursued there under my direction may suffice for our present purpose. I may, however, remark by the way, that the system, because it is a system, recommended by Seymour and described in Loudon's *Gardener's Magazine* for 1826, has not been so generally adopted as its apparent simplicity would have induced us to expect. Not having seen it either extensively or very successfully practised, its superiority became a questionable matter; therefore I adhered to another mode, presenting to me superior claims, because conforming more to the natural character and habits of the tree, advantages in my humble opinion not to be overlooked; as by this system a more regular distribution and elaboration of the sap is maintained, and thereby assistance to provide the kind and quantity of wood so desirable to induce health, secure a crop, and prolong the age of the tree. The mode of training which I commenced with in 1832 is also described in Loudon's *Gardener's Magazine* for 1834, and seems to have been successfully practised by the able author of that paper for thirty years. This system deviates from the old fan manner of training, by regularly bending the branches in a curvilinear manner from the bole of the tree to their extremities, and giving them a slight tendency to the top of the wall. In this plan of training, the grand principle is, to elongate the under side branches, so as to give them precedence of the central ones; this will regulate the propulsion and distribution of the sap, and moderate the shoots in the centre of the tree. By the adoption of this very simple and natural system of training the

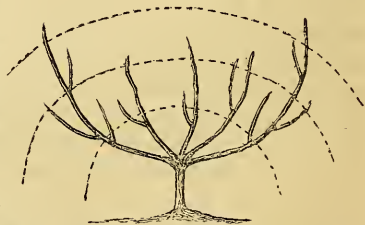

Fig. 20. A Peach Tree, three years after planting, trained in Mr. Errington's manner.

peach tree, various inexplicable failures will be avoided; such as premature decay, an unequal quantity of young wood in the centre of the tree, and the constant and grievous calamity of losing the entire under limbs, and completely disfiguring it for

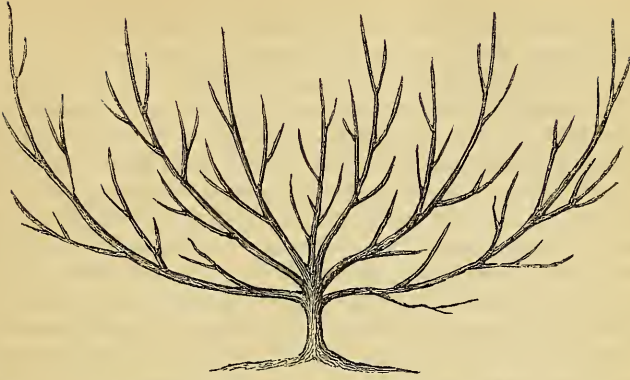

Fig. 21. A full-grown Peach Tree, trained in Mr. Errington's manner.

ever. The subject of training might fill a volume to little purpose: enough has been said to explain the principle which I have preferred in practice, and am solicitous to see generally adopted.

To those who have acted upon these principles, the process of pruning will be rendered a less difficult matter than under more untoward circumstances, especially at winter pruning, when it is indispensable to cut away enormous quantities of young wood. This will be in a great measure obviated, particularly when a system of summer pruning is practised. Wherever the peach is cultivated upon scientific principles, an annual dis-budding will always take place when the young shoots are about 2 in. long, which will generally be about the end of May. Select the shoots always for next year's bearing as near as possible to the bottom of the present bearing wood, and rub all the others off unless there is any scarcity of young wood, when it may be requisite to leave for winter regulation a few shoots occasionally. As to the buds which are intended to allow fruit to swell, instead of rubbing them clean off close to the shoot, it will be better to pinch them out half an inch from the wood, as the few leaves left at the base will assist in swelling the fruit. Any shoots that are intended for bearing wood and are growing out too vigorously, should be stopped back; and any of the leaders which may appear unusually strong should have their points pinched out, that they may make fresh growth and throw out laterals. The winter pruning should commence the last fortnight in February, and end the second week in March; during this period the flower and leaf buds will be readily distinguished, the former by their fat obtuse form, the latter by their pointed form, enabling the operator to proceed with certainty and rapidity.

Thin out the bearing wood to about 6 in. apart, and occasionally cut out some of the intervening small branches where any thing like confusion exists, and shorten back every bearing shoot at a leaf bud, one half or two thirds, according to its strength; and any branches affected with decay or gumming should be removed, and the tree regulated accordingly. In pruning, always cut behind the bud and about a quarter of an inch above it.

I have always until lately entertained the strongest aversion from all kinds of washes, except clean water, but have been compelled by adverse visitations to have recourse to something besides water. The summer of 1838 will long be remembered by me, as a season when peach trees suffered greater injury from aphides, than in all others put together during my remembrance. No sooner did the leaves make an effort to develope themselves in the spring, and throughout the whole summer, than they were attacked and utterly destroyed. I applied in their turn pure water, lime water, tobacco water, soapy water, and powderings of sulphur, but all my efforts to subdue them proved utterly unavailing. The attention the trees received during the entire season was beyond all precedent, and at the close of the autumn I had the mortification of witnessing all my assiduity and application totally frustrated. From the high condition in which the roots were, and the fruitless efforts made to produce wood, it may be supposed the extravasated sap was oozing out in all directions. The injury thus inflicted upon the most splendid trees I ever beheld, was to me heart-rending; principal branches were, in some instances, so seriously injured, as to render them of no further use; and two beautiful trees were damaged to such an extent, that I dug them up, — with what feelings I will leave my brethren of the blue apron to guess. In this state of desperation, I was compelled to try experiments, which were happily attended with the most satisfactory results. Lime water was strongly recommended by some eminent horticulturists, as a preventive to attacks of insects, and every disease to which peach trees are subject, by keeping them regularly syringed with it during the winter. This I found beneficial, but it bore no comparison to the following composition:—half a peck of unslaked lime, a quarter of a peck of fresh soot, two pounds of soft or black soap, and one pound of black sulphur (sulphur vivum). The soap was dissolved in a vessel with boiling water, and the other ingredients afterwards mixed with it, and just as much water added as reduced the whole to a creamy consistency. As soon as the pruning was finished, and previously to nailing, I made one man regularly besmear every part of the tree, branch by branch; a fine day was selected for the purpose, which soon dried the composition, showing any place that had escaped. In order to secure to every part a coat of the mixture, I caused

another man to follow about half an hour afterwards, and carefully wash every crevice that had been missed by the first person. The composition was applied with a piece of soft cloth or sponge, and used as hot as the hand could be suffered in it. Great caution was necessary not to rub off the flower buds, which at this season are very prominent. Those trees only that were most seriously injured were washed with this mixture. As the season advanced my hopes brightened, and I had the gratification of witnessing the most complete success; trees, of which there remained but the skeletons of what they once were, the mere remnants of former grandeur, presenting a degree of health unexampled as far as my experience goes, clothed with a redundancy of wonderfully large and densely green foliage, and not a curled or blotched leaf visible. The trees washed with lime water were in good condition, but not entirely free from occasional attacks of aphides. The difference in health of those syringed with lime water, and the others that were washed with the mixture, could be easily distinguished the whole length of the garden. Aphides are more particularly generated in dry and clear weather, and I am convinced they cannot exist, much less reproduce themselves, on trees clothed with this composition during the influence of a clear sun. The noxious exhalations may probably be the cause of this. Having pointed out the efficacy of this wash to several eminent practical gardeners, they concurred as to its apparent wonderful excellence; therefore, after the publicity which I now give it, it will remain for others to prove its utility.

In nailing peach trees, I would recommend the use of new shreds, and I have always directed the dark-coloured ones to be selected for this purpose, as presenting by contrast a much neater appearance; the pieces employed as shreds are generally cut too large, little strength being required, as they are only expected to last one year. I would, however, strongly insist upon all peach walls having copper wire extended longitudinally, and fastened to eyes let into the wall. The wires should be about 6 or 7 inches apart, and the trees fastened to them with bast ligatures. There is much to approve in this, and to recommend it for general adoption, both as regards present as well as ultimate economy: a practical man will at once see the great advantages resulting from such a system, and the uninitiated will soon discover that a man can tie two trees in the same time he could nail one, and his walls will not be subject to the injury of having annually some thousands of nails driven into them.

Whenever the blossoms begin to be partially developed, I advise protecting the trees with bunting; this will be money well expended; the bunting will be found very useful during

summer for other purposes, such as shading plants in hothouses, and covering various kinds of fruits from birds and wasps. The bunting should be stretched from the coping of the wall to the ground, and fastened 3 ft. from the bottom of the wall. This protection will be of great service to keep off the cold rains and frosts, so prevalent at this season: during fine days the bunting should be removed, and the trees exposed to the full influence of the sun's rays; and when the petals of the blossoms are all dropped, the bunting should be entirely taken away. From this time until the fruit begins to ripen, and immediately after it is gathered, refreshing and sometimes copious waterings with the engine should be given, according to the state of the atmosphere; which will keep the trees clean and free from red spider. Clear lime water may with advantage be applied when insects abound.

Peach tree, and indeed all other kinds of fruit tree, borders should be occasionally forked up; no spade should ever be permitted in such a place, nay, not even amongst gooseberry bushes: the manifest injury annually committed by this implement, and the disposition to use it amongst common labourers in gardens, ought to put every ardent cultivator on his guard. No vegetables should ever be cultivated on fruit tree borders: this would provoke an annual supply of manure, and be the forerunner of all the evils which I am so anxious to see banished from the common practice of gardening.

Far less attention has hitherto been paid to thinning peaches and nectarines in a young state, than our limited practice would induce us to follow: on this depends the full size of the fruit, and with it the flavour; and on the regularity and frequency of the process the security of the crop in a great measure rests.

The first thinning should take place at the same time with the disbudding; the second when the summer shoots are sufficiently advanced to require nailing or tying; and, finally, at the time of the second nailing of the current year's shoots, which will be just after stoning, when no danger need be apprehended of the fruit falling off. During the period of stoning, I would insist on the suspension of all waterings, particularly to the border; but, as soon as the swelling begins after stoning, I always deem it advisable to keep the border moist with moderate waterings, until the fruit is approaching to maturity; this assistance, when the last effort is making, will wonderfully aid the trees to swell their fruit to a full size.

I flatter myself that these observations on the culture of an important fruit, may be of use to some of the members of our profession. They have at least the merit of being the result of patient attention and practical experience.

*Exeter, Jan. 1841.*



ART. VI. *Mode of destroying the Green Fly on Peach Trees.*  
By COTSWOLD.

As soon as the insects begin to appear, I prepare to get rid of them by making the water-pipes as hot as I can. I then fill the house with tobacco smoke, and water the pipes afterwards, so as to fill the atmosphere of the house with steam, at the same time that it is full of smoke. After the steam is condensed on the leaves and points of the young shoots, globules of the tobacco-oil will be found on the surface of the globules of water, something in the same way as the prismatic colours are shown in a soap-bubble blown from a tobacco-pipe. This operation not only completely destroys the green fly, but also the scale upon the upper surface of the leaves of orange trees, because the insects are exposed to the descending vapour. This vapour, when deposited on the leaves, has quite a caustic taste. I have practised this method for years, and always with complete success.

Jan. 17. 1841.

---

ART VII. *On growing Three Crops of Grapes in One House.*  
By T. S. W.

IN your notice of the gardens at Hungerton Hall, Vol. XVI. p. 570., you describe a mode, practised there, of growing three crops of grapes in one house in one year as being new, and well deserving of imitation. That it is a mode rarely adopted by gardeners I am aware; and I would wish to draw their attention to this most important subject. Frequently have I regretted seeing vineries made no manner of use of one half the year, when, by a little management, ripe grapes might be produced in them seven or eight months in the year; so that one house might serve the purpose of two or three.

This method of growing grapes was practised several years ago at a place a few miles north of London, where I filled the situation of under-gardener. The house was 45 ft. long, and 18 ft. wide: a pit occupied the centre, formerly used for fruiting pines. The flue entered the back of the house at one end, and was carried round the front and under the back pathway into the chimney at the same end the flue entered. Open wooden work was placed over the back flue to walk upon.

Vines were planted in the front pathway next the pit, one under each rafter: these produced the first crop of grapes. We began forcing them in the beginning of February, and they were ripe by the middle or latter end of June. Those for the second crop were planted outside the house, in the front. They were introduced into the house in the latter end of March or beginning

of April, and trained over the front flue and pathway, as well as up some of the rafters: these ripened their fruit in August.

The vine producing the last crop was planted at the front corner of one end outside: it was carried with a single stem up the end rafter to the back wall, where it was trained just under the coping to the full length of the house. A shoot or secondary branch from the main stem was left so as to come in at each rafter of the house when introduced. This was performed about the beginning of September, by entirely removing the end of the house for the purpose, which was afterwards replaced. The principal stem was trained to the wires near the back wall, and the smaller branches down the rafters towards the front. At this time, the first crop of grapes being cut, the vines were taken across the flue and outside the front sashes, there to remain until the February following.

The vine planted at the end was a cutting from the celebrated Valentine's vine, and an exceeding good bearer. I have known it to ripen off upwards of 300 bunches; and, although not extraordinarily large, the berries were well swelled and coloured. I do not recollect ever seeing a shriveled berry upon the vine. I have cut grapes from it on the 8th of February, and they were then in excellent condition.

I feel convinced vineries might be built, with little extra expense, that would answer the purpose of growing three, if not four, crops of grapes in one year: and at some future time I may possibly send you a plan of one well adapted for the purpose. [We shall be glad to receive it, and lay it before our readers.]

*Sussex, Dec. 26. 1840.*

---

ART. VIII. *A Method of sowing Peas and Beans in Boxes for Transplanting.* By H. O.

I BEG to draw the attention of your readers to the following method of growing and transplanting peas and beans, without materially injuring their roots.

Procure two boards, about 6 in. broad, and as long as the border into which you intend to transplant them is wide, say 8 or 9 feet; bevel off one edge of each board; on the edge thus beveled of one of the boards drive in three or four small staples at equal distances, and the same distance from each end as from each other. On the beveled edge of the other board drive three or four small hooks, or pieces of strong wire bent, to hook in the staples, at the same distance from each other as the staples: by now hooking them together, they will form two sides of an equilateral triangle. At each end of one of the boards should be nailed a piece of wood of the shape of the above-mentioned

triangle, and the other board must be fastened to this by hooks and eyes. It is now ready to be filled with soil for sowing the peas; but it will require two blocks of wood to stand upon, one at each end. Therefore, have a triangular piece cut out, or two blocks of any length cut so as to hold any quantity of troughs you wish. When they are to be transplanted, drills should be drawn, and the troughs placed in them: unhook the two ends; the side boards are then easily unhooked and taken away, when the peas will fall into the trench, and may immediately be moulded up.

*Essex, Jan. 6. 1841.*

---

ART. IX. *An accidental Discovery of an improved Mode of blanching Sea-kale and Rhubarb with Peat Soil.* By DAVID ROBERTSON.

IN 1824, being then gardener to Captain George Bryan, Jenkinstown, in the county of Kilkenny, the sea-kale beds were adjoining the frame ground; and, in consequence of some improvements, a quantity of peat was removed in November, part of which was laid above the beds. In clearing it away in January, the kale that was under the peat was finely blanched, extremely clean and white, and fit for the table; while that portion which was not covered with peat had not begun to vegetate.

Being much struck with the rapid progress of its growth, and convinced of the excellence of the covering thus accidentally employed, the following season, in November, I had a bed covered with free peat soil to the depth of 10 or 12 inches, and forced with stable litter in the usual way; and it was fit to cut at Christmas. In this case the use of the peat is chiefly for blanching. When the season is more advanced, stable litter may be dispensed with; and beds covered with peat in November, or later, according as it is required, would be fit to gather in the intermediate season between the forced sea-kale and that in the open ground which had not been covered with peat. The peat evidently forwards its growth a few weeks without forcing with litter; acting, doubtless, as a non-conductor to the heat in the soil, in the same manner as a covering of snow:

Rhubarb may be successfully treated in the same manner, only it requires a greater depth of peat, according to its height; say 15 in.

As far as my observation extends, the peat is far superior, for both sea-kale and rhubarb, to coal ashes or other substances, and also better than pots, the kale or rhubarb being more effectually blanched and better flavoured.

*Stanwell Nursery, Edinburgh, Dec. 1840.*

ART. X. *Comparative Results from cultivating Nine Sorts of Celery.*

By JAMES SEYMOUR, Gardener to the Countess of Bridgewater, at Ashridge Park, Herts.

ACCORDING to promise, I send you the following remarks on nine sorts of celery, which I grew in the year 1840. They were treated all alike as to the time of sowing, planting, &c. The seed was sown on the 16th of March, and afterwards treated as I recommend in my article on celery, in your Volume for 1840, p. 91. I hope that other gardeners will send you an account of the experiments which they make on vegetables, fruits, flowers, &c., which I consider is always of the greatest importance to your readers, and particularly so when they come from practical men. I shall be glad to see the opinions and remarks of gardeners that have grown the following sorts of celery, their manner of treatment, &c.

| Sorts.                  | No. of Plants. | Proved solid. | Proved hollow. | Remarks.   |
|-------------------------|----------------|---------------|----------------|--|
| <i>Red Celery.</i>      |                |               |                |  |
| Bailey's Gigantic       | 63             | 52            | 11             | Grows quick, but runs soon.  |
| Manchester Large Giant  | 69             | 61            | 8              | Coarse, and bad-tasted.  |
| Perkins's Large         | 62             | 26            | 36             | Very bad; not worth growing.   |
| Russian Pink            | 67             | 25            | 42             | Do. do.  |
| Seymour's Solid         | 141            | all           | none           | Very solid, of a peculiar growth, and fine flavour.                                  |
| <i>White Celery.</i>    |                |               |                |  |
| Kentucky, or Lion's Paw | 20             | all           | none           | Very solid; of slow growth; too broad in the leaf stalk.                             |
| Law's Giant             | 68             | all           | none           | Very solid; a good sort.   |
| Siberian                | 20             | all           | none           | Very solid; a good sort.   |
| Seymour's Superb White  | 324            | all           | none           | A very superior sort, of large size, good flavour, and well adapted for early crops. |

These remarks were made in September. The plot of celery was inspected by the following gardeners, viz., Mr. H. C. Ogle, gardener to A. E. Fuller, Esq., Rose Hill, near Robertsbridge, Sussex; R. C. Kingston, gardener to R. Fleetwood Shaw, Esq. Brantingham Hall, near Hull; William Pinkerton, gardener to Sir Ashley Cooper, Bart., Gadebridge, Hemel Hempsted, Herts; Mr. James Stone, late of Syon House Gardens, Isleworth, Middlesex; and many more who have paid Ashridge gardens a visit during the summer of 1840: and all have highly praised our two sorts, and considered that they were decidedly the best, particularly the Superb White.

The Superb White is a very good sort for early growing, as it is the very last to start of all others I know. Indeed it is rarely to be found to run at all, if properly attended to with water, &c. till it is all consumed; which is not the case with any other sort I am acquainted with.

The Superb White has perhaps been grown to as large a size as any other white sort of celery in cultivation, if not larger; and is considered by all who have tasted it to excel all others in excellence of flavour and brittleness, when well

blanched, as it has none of that stringiness which is so common in all the larger sorts that I have grown. This sort requires a longer time to blanch than many other sorts, as it is so very solid and firm in the stalk.

The Superb White has been grown very fine by Mr. George Seymour, gardener to His Grace the Duke of St. Albans, Redborne Hall, Brigg, Lincolnshire; Mr. James Kingston, Saltmarshe, Howden, Yorkshire (see *Gardener's Magazine*, Dec. 1839, and Feb. 1840); and last summer by Mr. Robert Hinsley, Carlton Bridge, Snaith, Yorkshire. One head of this sort weighed nearly 15 lb. (when dressed for the table), and two more weighed from 11 lb. to 12 lb. each head; and two long rows weighed on an average from 9 lb. to 10 lb. each head. The seed of these was sown in February, and planted in July, in trenches, with an abundant supply of good rotten dung, mixed with a fine loamy soil (warp), and grown near to the river side (Aire and Calder). The plants were direct from my father, of Carlton Hall (the seat of Lord Beaumont). I may likewise add, that the Superb White is much approved of by Mr. George Mills, gardener to the Baroness De Rothschild, of Gunnersbury Park, Acton, Middlesex. In a letter, dated 22d Sept. 1840, Mr. Mills says: "I am much pleased with your celery, it is doing well with me. I have none I like so well." I might add other names, but I consider what I have said already will be sufficient to induce most gardeners to give it a trial. Messrs. H. Lane and Son, Nurserymen, Great Berkhamstead, Herts, having raised a good deal of seed of both sorts last year, will, I have no doubt, be very punctual in attending to all favours committed to their charge.

*Ashridge Kitchen Gardens, Jan. 16. 1841.*

---

ART. XI. *Remarks on placing the Entrance to Beehives.*

By JOHN WIGHTON.

SOME apiarians have lately advanced that, if bees were left to their own choice, they would prefer descending to their cells, to ascending. If this be correct, the common method of placing the entrances in beehives must be wrong. But this I do not believe, nor do I think that descending is more conformable to the natural habit of bees.

With a view to test this, I placed a strong swarm in a wooden hive, 6 ft. high, and 7 in. square in the inside. This was divided into two equal apartments. In the lower one I made two entrances, one at the bottom, the other at the top; and in the upper one, I made one entrance in the centre. I put the bees into the lower division, and closed the opening underneath. They began to form their cells at the top in the usual way.

Three days afterwards I opened the lower hole, and the bees forsook the upper one, preferring to enter below. Why they did this may appear strange; but it can be accounted for, not, as some would imagine, from their having blocked up the upper opening with their combs, which was not the fact, but from the singular position of the bees when forming their cells. This requires explanation, particularly for those who are not acquainted with their very curious mode of beginning their cells.

To an ordinary observer, a swarm beginning to form their cells appears only a confused mass of bees, hanging together in a dense cluster: but, on closer examination, the busy workers within may be seen through the numerous openings left all round the cluster for those bees to have free ingress and egress, which are employed in forming the cells. The bees in my hive having ascended to the top, as already mentioned, began of course to form their cells in the manner described. When they came to the openings in the cluster, it was easier for them to drop into the empty space below, to get out, than to make their way to a particular point above: for, in this case, they must either have travelled round the cluster, or first dropped down, and then crept up the side of the hive, in order to get out at the hole above; and the same inconvenience would have attended their return to the hive. All this I observed by having glass at the back of the hive: and it was surprising to see how fast the bees dropped down to get out of the hive, after I had opened the lower hole. One might almost suppose that whoever invented the common hive was aware of the fact just mentioned; for its construction is admirably adapted to the formation of the cells.

The charge against bees, of their losing time by having to ascend through their hives, is not worth attention; at least I had no reason to complain of it in my six-foot hive, for the bees filled the lower half of it in a fortnight. After that, I admitted them into the upper division. They went up at once to the top, and began their cells as they had done in the space below. Although there was an entrance in the centre of this upper division, they never made use of it, but preferred going up and down through the whole hive. To ascertain if this was not the mere effect of habit, I closed the lower opening. This caused much confusion at first, but the bees soon got used to the upper entrance. After a few days, I opened the lower one again; and they soon forsook the top opening, and seemed pleased to go out and in again by their favourite way.

It may be asked what caused the bees still to prefer the lower entrance, when their combs were finished, and the previous reason of their clustering no longer existed. To this I have to observe, that, the combs being fixed at the top, there was not the same thoroughfare left to pass between them as below. Bees

usually place their combs north and south, and continue them to within half an inch of the bottom of the hive, which allows a sufficient passage to go to their cells. Suppose, however, that a thoroughfare had been left at the top: I still believe that the bees would prefer getting to their cells by the lower way. Some deny this, and insist that they must find it easier to go down than to ascend with their load, on entering the hive. Judging, however, from the actual fact of their preferring to ascend with their loads, it may be fairly concluded that they even find it easier. It must be remembered that the honey bag is in the hinder part of their body; and its weight might tend to propel them forward too powerfully when descending. It is also to be observed, that wasps and hornets enter their nests from below. If all that has been said should not have convinced the reader that the natural disposition of bees is to ascend, let him place a bee in the middle of a window-pane, and he will always find it creep upwards before it descends.

*Cossey Hall Gardens, July 25. 1840.*

## REVIEWS.

ART. I. *The Journal of the Royal Agricultural Society of England.*  
Vol. I. Part IV.; and Vol. II. Part I. Jan. 1841.

WE noticed Part III. of the 1st volume of this excellent Journal immediately on its appearance (see our Volume for 1840, p. 169.), and the Parts that have since been published are now before us. They abound with excellent articles, most of which may be perused with advantage by the gardener as well as the farmer. An experiment with Poittevin's Manure (desiccated night-soil), laid on at the rate of 36 bushels per acre, proved it to be equal in effect, for the first year, to farmyard manure laid on at the rate of 25 tons per acre; but whether it will "carry the different crops through the course equally well with the farmyard manure" is very doubtful. — An article on the Parsnep, by Col. Le Conteur, shows that the average crop, per statute acre, is from 9 to 11 tons, but small spots have yielded at the rate of 27 tons per acre; a quantity nearly sufficient for 10 cows during the six winter months. Parsneps, if boiled, will fatten oxen, pigs, or poultry, in an "extraordinary manner;" and they are an excellent preparatory crop for wheat. An experiment is now in progress to ascertain the comparative value of the parsnep and new white carrot. Several experiments with nitrate of soda seem to prove that it increases the produce of the Gramíneæ.—An article on Animal Manures contains much chemical and theoretical matter, and also a great deal of a directly practical value. The nature of the manure of animals depends, of course, upon the kind of food by which they are nourished. The most valuable part of the manure produced by every animal is its urine; and, in using it, it should either be mixed with water and fermented, or mixed with straw or soil. We shall, however, prepare an article on the subject for this Magazine, from the very long, elaborate, and most valuable one now before us.

From a paper on the Management of Bees, we make the following extract, which we recommend to our correspondent Mr. Wighton:—

"I have kept bees more than twenty years; have tried Huish's, Nutt's, and various other plans; but the one suggested by this industrious insect itself I

have found to be the most simple, cheap, and successful; and it will not cost the cottager more than sixpence to adopt it, in addition to his old hives.

"Some years ago I placed an empty butter-tub under the board on which the hive rested: the sun cracked the board, and the bees, enlarging the opening, took possession of the tub, and, after filling their own hive, deposited 26 lb. of honey and comb in the tub below. This I took possession of for my own use, leaving their hive full of honey for their winter's consumption. By improving on this simple plan, I have carried off the prizes for honey at the Henley Horticultural Society for the last four years. A board, half an inch in thickness, 18 in. in width, and perforated with two holes, each an inch in diameter, is placed between the hive and the butter-tub. The tub should be placed under the hive as early as March; the bees having a great dislike to any disturbance of their arrangements. I last year took upwards of 40 lb. of honey in this way, although the season was so bad, and an ample supply of food was left for the bees to subsist on during the winter. This plan will prove a good substitute for the 'rear' used to enlarge the common hive; with this advantage, that a supply of honey can be obtained from the strong swarms as well as the old hives.

"I have never found occasion to feed the bees from which honey had been taken in the mode described; but, previously to its adoption, I was in the habit of feeding them with coarse sugar boiled with beer, and a little old wax comb, to the consistence of a syrup. As an experiment, I once fed some bees with treacle made from grating 112 lb. of beet root, expressing from it one gallon of juice, and boiling this with one teaspoonful of sulphuric acid (commonly called oil of vitriol), and three teaspoonfuls of common chalk or whitening in powder, which will clarify it and throw off all impurities, leaving, on evaporation, a clear syrup fit for feeding bees." (p. 204.)

Part I. of Vol. II. contains a Report on the Diseases of Wheat, by the Rev. Professor Henslow, in which the fungi, smut, dust, bunt, rust, mildew, ergot, pepper-corn, and wheat-midge are described, and also the means of preventing them, or of alleviating their effects.—A paper on the White or Belgian Carrot shows this to be a most valuable root, producing a crop "not only much more valuable per ton than any other green crop we have, but also heavier per acre, and raised at less expense, by at least one half, than that attending the cultivation of the turnip." (p. 40.) Lord Ducie found the Early Horn Carrot more productive than the Altringham Carrot, the produce being at the rate of 18 tons 15 cwt. per acre, and the expense 6*l.* per acre.—An article of the Agriculture of the Netherlands, by the Rev. W. L. Rham, has some remarks on liquid manure, and on the treatise on animal manures before mentioned. The following quotations are pregnant with instruction of the most useful kind:—

"The most rapid improver of loose sands is rich liquid manure, affording immediate nourishment to plants, which otherwise, for want of moisture, would languish, even with an abundance of solid dung; for this last remains altogether inert, until it be moistened and partly dissolved. When the fibres of the roots spread, they bind the loose sand, and prevent the too rapid evaporation and percolation of the moisture. These roots remain in the soil when the crop is reaped, and by their decay afford organic matter for the nourishment of the next crop. Hence it is evident that the plants which have long spreading roots, if they can be made to vegetate vigorously by an ample supply of liquid manure, greatly improve very light sands; and, in process of time, by the decay of the vegetable fibres, produce such an increase of humus as entirely to change the quality of the soil.

"The collection and preparation of liquid manure is an object of primary importance with the Flemish farmer. Every farm has, near or under the stables and cow-houses, one or more capacious tanks, into which the urine of the animals and the washings of the stables flow; and every exertion is made to increase the quantity, and improve the quality, of the tank liquor.

"The tanks are generally sunk below the level of the ground, and have the



sides built of brick, and the bottom paved: they are of various dimensions, according to the number of cows and horses on the farm.

“The value of cow’s urine, with other animal substances dissolved in it, is universally admitted by all the farmers of sandy soils in the Netherlands: the theory of its preparation and application to the soil remains, however, yet involved in some degree of obscurity; and some eminent chemists have doubted whether the collection of it in a tank is the most economical mode of preparing it for the soil.

“In the very valuable *Treatise on Animal Manures*, by Sprengel, it is more than insinuated, that the advantages of the urine tank are much over-rated; and that it is better to mix the solid and liquid parts of dung together, and form them into composts with rich earth, as is often done in England and other countries, than to preserve the fluid portion by itself in a tank, to be used separately on the land, after it has gone through a certain stage of decomposition. Without disputing the correctness of the chemical principles on which this opinion is founded, we may hesitate before we condemn or undervalue a practice which has produced such wonderful effects in the improvement of the poor sands in the Netherlands.

“Liquid manure may be applied to plants in every stage of their growth, if it be judiciously diluted, so as not to injure the young and delicate roots by its caustic nature. It invigorates their growth more than we could anticipate from a knowledge of its solid component parts. It is no doubt sooner exhausted, because it is rapidly absorbed by the roots, and its elements enter into new combinations. If some of the more volatile parts, as ammonia, fly off in the process of decomposition which goes on in the tank, it is probable that a much greater portion of these elements flies off from the solid dung while it remains in the ground, and before it is in a fit state to be taken up by the roots, which can only happen when rain renders it liquid. All those who have had long experience of the good effects of liquid manure on light soils, persevere in its use, whatever objections may be urged theoretically to its being preserved separately.

“On stiff impervious soils, the use of liquid manure may not be so advantageous, and the reasonings of chemists may be correct. On these soils it is seldom used, except when they are in grass, or when cabbages are planted; and composts prepared with straw, earth, and dung, with the liquid portions occasionally poured over them, are found to be a more effectual and lasting manure. The Swiss, whose principal object is to have a supply of food for their cattle in winter, when the mountain pastures are covered with snow, and who devote much of their attention to the cultivation of roots and artificial grasses, use the liquid manure in a very condensed state, collecting the water which has been poured over their heaps of dung, after it has filtered through them, and been saturated with all the soluble portions of the dung. This, which they call *lizier* in French, and *mist-wasser* or *gülle* in German, is carried on the land immediately after the grass, saintfoin, or lucern has been mown, and produces a second and third crop in a very short time. Cabbages, potatoes, and the varieties of the beet are invigorated in the same manner; and thus, in the short summers of the high mountain valleys, crops are brought to maturity, which, without the use of liquid manure, would never have had time to ripen. But let it not be imagined that either the Flemings or the Swiss undervalue the solid manure which is produced by the mixture of litter with the dung of animals, collected in heaps, where it heats and decomposes. They are as careful of this, and as anxious to increase it by every means in their power, as the best English farmer can be.

“In order to increase as much as possible the quantity of solid manure, there is in most farms a place for the general reception of every kind of vegetable matter which can be collected; this is a shallow excavation, of a square or oblong form, of which the bottom has a gentle slope towards the end. It is generally lined on three sides with a wall of brick to keep the earth from falling in; and this wall sometimes rises a foot or more above the level of the

ground. In this pit are collected parings of grass sods from the sides of roads and ditches, weeds taken out of the fields or canals, and every kind of refuse from the gardens: all this is occasionally moistened with the washings of the stables, or any other rich liquid; a small portion of dung and urine is added, if necessary, and when it has been accumulating for some time it is taken out, a portion of lime is added, and the whole is well mixed together: thus it forms the beginning of a heap, which rises gradually, and in due time gives a very good supply of rich vegetable mould or compost, well adapted to every purpose to which manure is applied.' (*Outlines of Flemish Husbandry*, p. 22.)

"In the preparation of the land for the different crops, the Flemings and Dutch do not use less solid manure than we do, and the liquid is an additional means of producing a certain and abundant crop, and not merely a substitute for the dung heap.

"The great secret in the improvement of poor land is to increase its fertility by judiciously stirring, pulverising, and mixing together the different earths of which it may be composed; adding those which are different, where it can be done without too great expense of labour or capital; and, above all, impregnating it throughout with portions of humus, that is, organic matter in a state of decomposition.

"The mechanical texture of the soil is of the first importance; for on this depends the proper retention of moisture, without superabundance or stagnation, which implies that the subsoil is naturally porous, or made so artificially, especially in northern climates, where the evaporation is slow, and much rain falls throughout the year.

"The roots of plants, in their tender state, must find pores in which they can shoot and increase in bulk, for which the air and water are indispensable. They must also find substances which can yield them carbon, in a soluble state, as carbonic acid, which is produced in all vegetable fermentation.

"In water and air are contained all the other elements of vegetables, and even carbon in a small proportion. If the pores are so large as to let the moisture through, or allow it to evaporate readily, vegetation ceases, and the plant soon dies: if they are filled with water, so as to exclude air, the same result follows. Hence it is evident that by altering the mechanical texture of a soil without any chemical change in its component parts, it may be made much more capable of supporting vegetation than it was before. The quantity of organic matter or humus which will sustain vegetable life is extremely small, when other circumstances are favourable. Hence, in the improvement of barren soils, the most essential process is to alter the mechanical texture. In clays this is effected by repeated tillage, when the situation allows the superfluous moisture to run off. This is the reason why good clays are in all countries looked upon as the best soils, and sands as comparatively inferior. A soil which contains but little argillaceous or calcareous earth in its composition was long considered as irreclaimably barren; but, when the alternative presents itself of starving, or making poor sands productive, means are soon found to correct their barrenness.

"As pure siliceous sand is too porous, the first thing is to add substances which will readily fill up some of the pores. Fine clay diffused through water does so most effectually; and it is astonishing how small a portion of pure alumina will consolidate a loose sand, and convert it into a good loam, the parts of which, when moistened, will adhere and form a clod in drying. Whenever this is the case, the soil can no longer be considered as barren; but it may not yet be fertile, however its porosity may be corrected: for this purpose it requires organic matter already so far decomposed as to be readily assimilated to the substance of the plants. When vegetation is active, and the organs of plants vigorous, there is every reason to suppose that water is decomposed by the action of the leaves; but this does not take place in the infancy of the plant. The roots must find some nourishment ready prepared and easily assimilated. This has a strict analogy with animal life. The infant finds its earliest

nourishment in its mother's milk, or, by the admirable contrivance of nature, in some similar substances. The body of a young chicken is formed from the white of the egg in which it was enclosed; and the yolk is a provision for the period which intervenes between its being hatched and the time when its little bill is so hardened as to enable it to peck, and take up insects or small seeds. The seed committed to the ground may be compared to an egg: the first expansion of the embryo is entirely from the substance of the seed; and, until the seed-leaves are fully formed, it takes little or nothing from the soil, except pure water. But after the real leaves expand, it requires more nourishment, and if this is not found in the pores of the soil, or if the roots cannot penetrate to it, the plant languishes and dies. It is of no use that plenty of rich manure is somewhere in the soil, if it be not accessible, or if it be not in a proper state to be absorbed by the tender fibres of the roots. The plant will die, as an animal would by the side of a chest full of provisions, which are locked up, or unfit for his organs of digestion. These principles lead naturally to the best practice in improving or cultivating the soil; and we shall find that the mode pursued by the Flemings admirably accords with the theory.

"The trenching and mixing prepare the soil for receiving the additions of organic matter. The roots are fed with a liquid manure readily taken up, and greatly invigorating, until a sufficient portion of humus is formed, which gives the most gradual and regular supply of nourishment. At the same time solid particles are deposited, which fill some of the pores, and begin that accumulation of humus which in time will convert the whole into a rich and fertile soil.

"It must be observed, that the smaller the particles of sand the better the soil will be after being improved. Coarse sand, each particle of which is a visible crystal, allows the humus to be readily washed out. It must be mixed with clay or marl to fill up some of its pores; and if this is not already done by nature it must be done by art, or all the labour bestowed on the cultivation, and all the manure expended, will never be repaid by the produce. It is, therefore, of the greatest consequence to all improvers of barren lands, to know, not only what proportion of siliceous and argillaceous earths there is in the soil, but also what is the actual size of the particles. This is very easily ascertained by means of the simple instrument, consisting of metallic sieves, which is described in the essay on the Analysis of Soils [*Journ. Eng. Agr. Soc.*, vol. i. p. 46.]. When a considerable proportion of the dry pulverised earth passes through the finest sieve, it is a sure sign that the soil, if not already fertile, can be easily made so. That which is most readily improved consists of a small portion of coarse sand, mixed with a larger portion of finer, and with a considerable portion of impalpable earth, partly siliceous and partly argillaceous and calcareous, so that when it is moistened it does not form a tough paste, but dries into clods easily pulverised between the fingers. The degree of fertility will depend altogether on the quantity of humus which is incorporated with this loam, and which the specific gravity readily discovers, the richer soils being the lightest, for humus is much lighter than any of the simple earths.

"Keeping this in view, it is easy to show the advantage or disadvantage of different modes of proceeding, which should vary with the nature of the original soil. In the natural earth which has never been cultivated, or which is dug up from a considerable depth below the surface, portions of different kinds of earth are found in thin layers, or in separate pieces, which, being pulverised and mixed together, want nothing but the addition of humus to make them a fertile soil. Here the use of the trenching-spade is evident. No other instrument could so well divide the earths and mix them in due proportions. The more the ground is stirred the better it becomes; and, by a course of cultivation which, instead of exhausting the humus, gradually increases its quantity, it becomes at last a rich mould, like that of a garden in which all plants suited to the climate thrive luxuriantly. In the progress to this state of fertility the soil must have passed through every intermediate state; and the

same process, which at any one period effected the improvement, must be judicious if applied to any soil similar in its nature. In agriculture, as well as in most arts and sciences, to stand still is the prelude to going back. The soil, under the hands of a skilful agriculturist, must not only be made to produce all that it is capable of producing, but its capacity for production must be continually increasing, until it arrives at that state when a further increase of humus would loosen its texture too much to produce many of the most valuable plants, which are the chief objects of cultivation; for, beyond a certain proportion, the increase of humus does not always increase the produce.

“These preliminary observations appear necessary, to enable those who may not have paid much attention to the theory of vegetation, to trace their accordance with the practice which experience and observation alone have suggested and confirmed. They may also be useful in suggesting to those who would imitate any particular system of husbandry the modifications which are necessary, where the soil, climate, and other circumstances are different.

“The advantages of stirring the soil to a considerable depth by trenching and deep ploughing, which only now begin to be generally appreciated in England, and the intimate union of the manure with every portion of the soil, have long been practically acknowledged by the farmers in the Netherlands.” (p. 54.)

Mr. Babington shows that the Flax-Dodder (*Cuscuta epilinum*) is common in flax fields in Shropshire, in Wales, in the West of Ireland, in Argyleshire, in Somersetshire, and in Dumfriesshire. In Somersetshire this weed is known by the name of the Mulberry, derived probably from the form and appearance of its bunches of pale pinkish flowers; in the West of Ireland it is denominated the Parasite plant. It was introduced into Ireland in 1836, by some Odessa flaxseed; but it is never found in American or Riga seed. “It is therefore manifest, the almost certain way of avoiding this troublesome weed is by obtaining American or Riga seed, and not purchasing Odessa seed.”

The Advantage of mixing Soils is shown in a prize essay by Mr. Linton; by whom a barren sand was rendered fit for producing good crops, by spreading 150 yards of clay on each acre, the expense of which was under 6*l.* The land is never so productive the first two years, or until the clay has got well pulverised and mixed with the sand, as it is afterwards; and will not grow a good crop or a fine sample of barley till five or six years after the clay is laid on. Mr. Linton therefore sowed oats, and succeeded perfectly.

A paper on the Reduction of Horse Labour shows a saving by two-horse ploughs of one fourth, and by single-horse carts of one fifth.

The remaining papers we must leave till another opportunity. As almost every gentleman of landed property in England is a subscriber to the *Journal of the Agricultural Society*, we hope they will lend it to their gardeners as well as to their bailiffs; for assuredly it is calculated to be of great benefit to both, provided they belong to the reading class of these professions. To those who do not belong to this class, the Journal, like every other work which treats of principles as well as practice, will in a great measure be a sealed book.

ART. II. *Catalogue of Works on Gardening, Agriculture, Botany, Rural Architecture, &c., lately published, with some Account of those considered the more interesting.*

*ICONES Plantarum Rariorum, &c.* By Link, Klotzsch, and Otto. Part II.

We have in our preceding Volume, p. 556., noticed the first part of this elegant work; that now before us contains descriptions and figures of 1. *Puya Altensteini*; 2. *Lobelia discolor*; 3. *Olinia capensis*; 4. *Oxalis Ottomii*; 5. *Microstylis histionantha*; and 6. *Oncidium carthaginiense Swartz.* The

plates are scientifically and beautifully drawn and coloured, and each is accompanied by numerous dissertations.

*Description d'une Nouvelle Espèce de Figuier (Ficus Saussureana).* Par Aug. Pyr. de Candolle.

This new species of *Ficus* was obtained by M. de Saussure, from Cels of Monte Rouge, under the name of *Galactodéndron nova species*. It flowered in Nov. 1839, and, having been examined by M. de Candolle the younger, was found to be a *Ficus*, and named after the gentleman with whom it flowered. It is nearly allied to *Ficus coriácea*, a native of the East Indies, introduced to Britain in the year 1772, and figured in Hooker's *Exotic Flora*.

*Huitième Notice sur les Plantes Rares cultivées dans le Jardin de Genève.* Par M. Aug. Pyr. et Alphonse de Candolle, Professeurs à l'Académie, et Directeurs du Jardin.

The plants enumerated are all in British gardens; and *Acrótriche depréssa* R. Br., *Maxillária Déppci* Lindl., and *Epidéndron Candóllei*, are figured in this notice.

*A Catalogue of the Plants growing in Bombay and its Vicinity; spontaneous, cultivated, or introduced, as far as they have been ascertained.* By John Graham. Published under the auspices, and for the use of the Agri-Horticultural Society of Western India. 8vo, pp. 254. Bombay, 1839.

This Catalogue was presented to the Agri-Horticultural Society of Western India, by John Graham, Esq.; it is not complete, but it will be continued by Mr. Nimmo, the friend of Mr. Graham. The arrangement is that of De Candolle, and it includes 169 orders, commencing with *Ranunculácea* and ending with *Fúngi*. As a tribute to the memory of Mr. Graham, we copy the following notice.

“ Mr. Graham, a native of Dumfriesshire, arrived in India in 1828, under the patronage of the late Sir John Malcolm, who was at that time Governor of this Presidency. He was honoured with the friendship and esteem of that great and good man, and lived in his family until he was nominated by him to the appointment of Deputy Postmaster-General, which he held up to the period of his death. He possessed a combination of qualities which peculiarly fitted him for the duties of his office. The natural kindness of his disposition led him to be courteous and obliging to every one who had business to transact with him, and to be ever ready and willing to investigate every complaint, and to rectify any errors that might have been committed by his subordinates; while, at the same time, no unreasonable applications or groundless complaint disturbed the equanimity of his temper: nor did he serve the government with less zeal and diligence than he served the public.

“ The performance of his arduous duties left him little leisure for the prosecution of his favourite pursuit: but the few and brief opportunities which were afforded him were eagerly laid hold of and improved; and it should be added, that one of the objects he was desirous to effect, while superintendent of the Society's garden, shortly after its establishment, was, to store it with an extensive assortment of rare wild, as well as useful, Indian plants, chiefly collected by himself.

“ His private virtues will be long held in affectionate remembrance by his sorrowing friends. There were a gentleness and modesty of manner, a simplicity and ingenuousness of disposition, an humble-mindedness, and a total freedom from guile and self-seeking, which engaged the attachment and esteem of every one to whom he was known. His whole character and conduct were habitually regulated by a deep sense of his own moral imperfection, and by an humble endeavour to act in all things in conformity with the Divine Will.

“ Mr. Graham expired at Khandalla, the favourite scene of his botanical researches, on the 28th of May, 1839, at the age of 34, after only a few days' illness. The intelligence of his death was received at every station within

this Presidency with an almost universal feeling of sorrow and regret, and his friends have testified their admiration of his character, and their sorrow for his death, by the erection of a handsome monument over his grave." (p. iv.)

To the European gardener and botanist this catalogue is interesting, as describing the appearance of many of our stove exotics when growing in their native habitats, and likewise as showing what European or American plants are also indigenous to India, or have been introduced there.

*Clématis grata* grows in hedges and thickets, and the feathery tails of its carpels give the hedges of India very much the same appearance as the travellers' joy does those of the chalky districts in the neighbourhood of London. The rocket larkspur is naturalised in Deccan gardens, where it is planted below orange and peach trees to keep down weeds. *Ráphanus caudatus*, the Java radish, has long tapering pods like whip thongs, and is much cultivated in gardens. Mignonette is introduced, and a universal favourite. *Crataeva Roxbúrgii* is a middle-sized tree, planted about temples and Mussulman tombs; and also near the abodes of the dead in the Society Islands. *Támarix ericoides* furnishes brooms, as heath does in Europe. *Hibíscus Ròsa sinénsis*, the "shoe flower," is held in great esteem, and several varieties are in cultivation. *Datura álba*, the thorn-apple, is common among rubbish about villages all over the country; it possesses very strong narcotic properties, and has on several occasions been fatally used by Bombay thieves, who administer it to deprive their victims of the power of resistance. The Chinese use *D. ferox* for the same nefarious purposes. *Ròsa índica* is common in every garden, and in flower all the year [as it might be on English conservatory walls]: it forms a pretty good edging for garden walks, when neatly kept. The common sweetbrier is a delicate plant in Indian gardens. *Cánna índica* is found in gardens every where, and is in flower the greater part of the year. Its leaves are used to thatch houses with in Cayenne. *Cupréssus gláuca*, the common Indian cypress, or cedar of Goa, is found in gardens in Bombay and the Deccan. There are some fine specimens in the peshwa's old garden at Phoolshaher; and also a little lower down the river, at Corygaum, surrounding an obelisk raised to commemorate the battle fought there on the 1st January, 1818. Col. Sykes observes that "the Deccan produces none of the coniferous family, except *Cupréssus*; but it should be added, that it is only found in gardens, or planted by the hand of man."

These notes, which are taken at random in turning over the leaves, show the kind of information which the book contains for the general reader.

*Catalogue of Plants belonging to the Natural Order Coniferæ, cultivated for Sale by Lucombe, Pince, and Co., Exeter Nursery.* Single sheet.

This is the fullest catalogue of *Coniferæ* which has yet been published: the number of pines being 63, of *Abies* 16, *Picea* 11, *Làrix* 6, *Cèdrus* 2, *Araucària* 4, *Cunninghàmia* 1, *Dámbara* 2, *T'hùja* 6, *Cállitris* 3, *Cupréssus* 8, *Taxòdium* 2, and *Juníperus* 27; in all, 151 species and varieties.

Our readers are probably aware that our talented correspondent Mr. Glendinning has lately joined the firm of Lucombe, Pince, and Co. In noticing this circumstance in a paragraph at the end of the catalogue, Messrs. Lucombe and Co. express their readiness to lend their assistance in the arrangement of arboretums and pinetums, and to aid in establishing scientific classification and correct nomenclature; without which, as they justly observe, assemblages of trees and shrubs lose great part of their value. An original and most valuable feature in the practice of Messrs. Lucombe and Co., and which we could wish to see adopted by all nurserymen, is, that of keeping by them a stock of labels, formed of cast iron and lead, for sending out with collections. The names are stamped on a plate of lead, and the indentations are filled in with white paint on a black ground. A disc on the shank of the label at once prevents it from being pushed too far into the ground, and from leaning either to the one side or the other. The stamping of the names on these

labels might form an occupation for workmen in weather when they could not work out of doors, for persons in workhouses perhaps, and for women and children. We intended to have given a figure of Mr. Glendinning's label, but must defer this till our next Number.

*Hints for an Essay on Anemology and Ombrology, founded partly on admitted Principles, and partly on Observations and Discoveries, recently made, on the Influence of the Planet Jupiter and its Satellites on our Atmosphere; with a Weather Almanack for 1841.* By Peter Leigh, Esq., A.M., Author of "The Music of the Eye." 12mo, pp. 58. London, 1841. 1s.

This pamphlet, like the *Music of the Eye*, is curious and original, and may interest such of our readers as study the weather scientifically. The following quotations are practical:—

"Perhaps summer in England, or the greatest influence of the sun, begins about three days after that full moon nearest the time when the period of daylight begins to be sixteen hours long: this is near the end of May or beginning of June; perhaps it ends about three days before that full moon nearest which the period of daylight is about twelve hours long, or the middle of September. Not that it is to be inferred that the sun has not a great deal of power very often after this; which is, perhaps, sometimes increased by the retentive power of clouds, or even their reflection and refraction, or magnifying power.

"Perhaps winter, or the least influence of the sun, begins about three days after that new moon nearest the time when the period of daylight begins to be only eight hours long, or the middle of December; and ends about three days before that new moon nearest the time when the period of daylight is twelve hours long, or about the third week of March. This, of course, as well as the period of summer, will vary in different climates, and in the localities of hills, and with the materials of which those hills are composed. It may also here be worth observing, that Kirwan says that July is the warmest month in places above 48° north latitude, and August in places below that latitude." (p. 10.)

## MISCELLANEOUS INTELLIGENCE.

### ART. I. General Notices.

*KOPES from metallic Wire* were manufactured in Germany so early as 1827, and they are now manufactured in Dundee. Though their chief use is for the navy and for railroads, yet there are various garden purposes to which they might be applied. For example: for supporting netting over a cherry garden; for supporting canvass or mats over a flued border; for serving as guy ropes to newly transplanted large trees, such as the spruces, nearly 100 ft. high, transplanted at Elvaston Castle, &c. A series of these ropes laid across a river, and fixed firmly at their extremities, would form the foundation of a cheap and durable bridge. Many other uses will occur to the gardener, the forester, and the agriculturist.

*Indian Rubber Pavement.*—Among the marvels of the times, a patent has actually been taken out for paving the streets of London with India rubber; and many scientific persons are sanguine as to its success. There is to be a substratum of wood, on which is to be put a facing of caoutchouc mixed with iron filings and sawdust, to a depth of several inches. This, it is calculated, will resist the ill influence of all weathers, and make the most delightful and durable pavement. (*Morn. Chron.*, Jan. 6.)

*Garden Culture of Exotics.*—There can be no doubt that the proportions of the different constituents of the ashes of plants have the greatest influence upon the vigour and productiveness of the plant itself; and I have no hesita-

tion in saying that the culture of plants (more especially the garden culture of exotics) will never be brought to anything like perfection till they have each and all been submitted to chemical examination, the proportion of all their saline constituents accurately determined, and the nature of the soil for each chosen upon these grounds. (*Madden in Quart. Journ. Agr.*, vol. x. p. 96.)

*Sending Cuttings by Letter.*— I saw a notice some time ago, in your Magazine, of a plan for sending small slips of plants to a distance by folding them up in oiled paper. I had previously sent some cuttings of geraniums a journey of 250 miles, by enclosing them in tinfoil, the edges of which were well folded, even so as to prevent evaporation; and, on their arrival at their destination, they were as fresh, to all appearance, as when first taken from the parent plant. The facilities of the new postage system may render such a plan very frequently available.—*W. Scurfield Grey. Stockton on Tees, Dec. 19. 1840.*

*The Maggot in Onions* cannot be destroyed without destroying the crop at the same time; but the perfect insect, which is a species of *Musca* not unlike the house-fly, may be prevented from laying its eggs on the young plants, by watering them twice or thrice a week, from the middle of May to the beginning of July, with any fetid liquid, such as stale soapsuds mixed with a little stale tobacco water. The fly lays its eggs in the axils of the leaves, and the caterpillar, when hatched, eats its way down to the centre of the bulb, where it remains, feeding on its substance, till mature, and it then eats its way out through the bottom or side of the bulb, and undergoes in the soil its next stage of transformation, coming out a winged insect in six weeks or two months afterwards. This information was given us by a very intelligent young gardener from Lancashire, John Catton, at present working in Rollison's nurseries, Tooting.—*Cond. Dec. 18. 1840.*

*That Amount of Instruction which is worthy the Title of Education* consists in such a direction given to the thoughts, by the nature of the lessons conveyed, as shall produce a permanent good influence on the mind and heart. In this view, a person may be so far instructed as to read and write well, without such direction having been given to the reading and writing as to constitute education. When education has been grafted upon instruction, the intellectual powers are cultivated, and the heart ameliorated. "Instruction operates on the mind, education on the heart; and we know that sin is engendered in the heart." Instruction must prepare the way for education, and becomes more and more competent as it advances. "Education, though not always successful, as no human method can be, is the most perfect instrument for restraining persons from vice and crime. Let those then who object to instruction improve the methods in use, and supply education in its stead; a sound and really efficient education, which will reach the understanding as well as the memory, the heart as well as the hand and eye; and which, while it teaches the people that they have duties to perform to their Maker and their fellow-creatures, will furnish them also with that knowledge which will enable them the more easily and the more efficiently to fulfil all their duties to themselves and their families, namely, that of providing for their temporal wants, of raising themselves above the temptations of poverty and the degradation of dependence. (*Morn. Chron.*, Dec. 26. 1840.)

*Music, as a Branch of Popular Education.*— Among the measures now in progress for the education of the people, the importance of music, as a branch of public instruction, has not been overlooked. A paper has just been printed and circulated under the authority of the Committee of the Privy Council on Education, announcing the establishment of a singing school in London for schoolmasters, and containing an account of the manner in which it is to be conducted. In this paper, which is ably drawn up, the great and now generally recognised benefits of music, as an agent in the religious, moral, and social improvement of the people, are placed in a strong light:—

"In those countries where the education of the people has received the greatest attention, instruction in singing has long been regarded as an im-



portant branch of school discipline. The sentiments appropriate to childhood and youth find expression in the music taught in the elementary schools; and lessons calculated to make a deep impression on the character of the children, and to influence their future conduct, are linked with the most pleasing associations in the songs sung in the schools of Germany and Switzerland. The religious duties of the school are rendered much more impressive, where simple but solemn music forms a part of the exercises.

“In this country, of late years, the importance of teaching vocal music in elementary schools has generally been acknowledged. It is now considered as an essential part of infant education, and is steadily making its way into other schools for the poor. The important and useful influence of vocal music on the manners and habits of individuals, and on the character of communities, few will be prepared to dispute. It is, however, satisfactory to know that the degrading habits of intoxication, which at one time characterised the poorer classes of Germany, are most remarkably diminished since the art of singing has become almost as common in that country as the power of speech; a humanising result attributable to the excellent elementary schools of many of the states of Germany.”

Two difficulties have hitherto stood in the way of our national cultivation of vocal music: first, the want of a method for teaching it in any schools, and particularly in elementary schools; and, secondly, the want of a machinery for bringing any good method that might be introduced within the reach of the masters of such schools. In order to surmount the first of these difficulties, the Committee of the Privy Council on Education has charged Mr. John Hullah, a gentleman of distinguished musical attainments, with the duty of preparing for the use of elementary schools, and for publication under the authority of the council, a course of instruction in vocal music, founded upon, and embracing all the practical points in, the celebrated method of Wilhelm, now in operation with such remarkable results in Paris. (*Morn. Chron.*, Jan. 14. 1841.)

A good deal will be found in our Volumes for 1829 and 1830, written by ourselves, and also by different correspondents, on the importance of music as a branch of popular education; but certainly, sanguine as we were then accused of being, we did not go so far as to anticipate the happiness which we now experience, after the lapse of only ten years, at the speedy realisation of our wishes. The progress which national education is now making in this country is indeed most gratifying; and, though it must necessarily be a number of years before the system is carried to such a degree of perfection as it is in Prussia, Bavaria, Wurtemberg, Baden, and Austria, yet who can predict the progress it will have made before another ten years have passed away? The idea that there is one kind of education for the rich and another for the poor, will probably soon be considered as unreasonable as that there should be one law for the rich and another for the poor. The young gardener will thus see that however much he may now be before his older brethren, when he comes to be an old man himself he will be hard pressed on by those who are now growing up to compete with him; and he should therefore take every opportunity which presents itself of storing his mind with ideas, or of adopting some business where the labour required is more that of the hands than of the head.—*Cond.*

*Amusement of some kind* is a necessity of all ages and all conditions. The poorer a man is and the more he is a slave of toil, the more needful it is that he should find diversion and refreshment of some kind for his weary spirit, and the more important that he should find it in enjoyments which are not sensual, and which, while they soothe his senses, refine them. The human heart is naturally so inquiet, morose, and jealous a thing—so apt to make self the centre of all its thoughts and sentiments, that the happiest man is he who can most frequently find the means of escaping from his own narrow personality, to fix his attention on something which is not himself. Interest him in the recital of some noble action, excite him by verses or songs which

give expression to lofty sentiments, or paint the beautiful features of natural scenery, and you will see him rejoicing in his own emotions, mastered and melted by the omnipotence of the arts. Music, the most seductive and purest of them all, is calculated more than all to exercise a sway over the popular heart, raising therein sensations alternately glowing and refined. The historical monuments of antiquity universally attest the influence of this art as a means of civilisation. Why, then, should we reject a means so powerful, at a moment when the springs of morals are so weakened amongst us? Governments which seek to secure the affections of the masses will do well to attract their confidence by procuring for them, as far as the power is in their hands, work, education, and amusement. Let the industrious poor, when assailed by the solicitations of the factious, be able to reply:—"We, too, have our share in the distribution of the social enjoyments; that share is adapted to our simple tastes, and proportioned to our scanty leisure. With it we are content; and, far from striking at a social condition of things in which we hold an honourable place, we are ready to defend it against every species of attack." For myself, I feel satisfied that the administration has rightly apprehended the wants of the people; it has justly felt that the labourer must have some diversion from his labour. His leisure hours it has sought to fill up in a manner which should be agreeable while it was useful; and, in that design, it has created this great and admirable system of scholastic institutions, appropriated to different sexes and various ages, and of which the musical one is, in my opinion, neither the least brilliant nor the least moral. I am firmly persuaded that the singing schools are worthy of all favour, and fit objects of the munificence of municipal councils. (*Athenæum*, April 11. 1840.)

---



---

## ART. II. *Foreign Notices.*

### RUSSIA.

*Courland*, May 10. 1840.—I agree with you, that ere many years pass over our heads, we shall have railroads over this country, and that they will be joined to those of neighbouring countries, so that by and by we may sing, bating the intervention of the herring-pond,

"To gang to London's but a walk."

The improvements since I first knew the world are incredible. The salted cucumbers I sent you grew in my own garden, and are produced by millions in every garden, or rather in all the gardens in Russia. They are sown in beds of good rich earth, the seeds about 5 in. apart. The runners they make are very short, and the cucumbers grow very thick upon them, requiring no care in the cultivation, and only occasional waterings to keep the seeds from drying, as we generally sow them in June, when our warm and dry weather commences; it will not do to sow them earlier, on account of the frost, i. e. cold. But as I prefer practice to theory, I send you a pound of cucumber seed [sent to Mr. Charlwood for distribution]: you may try a few this season in a warm sunny situation, making the seeds sprout before you put them in the ground, to save time. Ours is a dreadful climate, for, though I am writing to you on the 21st day of May *N. S.*, not a single tree of any kind is in leaf, the gooseberry bushes alone showing a few. To-day, the 22d, we have only 4° of warmth by Réaumur, whence you may conclude what a horrid climate we have, and one so truly uncertain. Last year I arrived the 11th (23d), and almost all my tulips had done blowing, and this year they have not opened. I must add that, in sowing the cucumbers, you must sow them in rows of 9 in. to 10 in. apart, which will leave ample room for runners.—*J. B. C.* *May 10.* 1840.

*Courland*.—This day, June 7. *N. S.*, our apple trees are not in blossom, or limes in leaf; in short I have never known so backward a season. I thought that summer would never commence; in fact we have only had warm weather

these last four days. My gardener has made for me a new kind of bed for growing the Russian cucumber. He makes a double frame of dung on the plain ground, leaving a space between the two rows of dung 18 or 20 inches wide, and about 18 in. high. The dung is not meant to give heat. In the trough thus formed by the walls of dung he puts fine rich earth, and sows his cucumber seeds in two rows. He assures me I shall have a better crop than in the usual beds, and in case of a rainy season no comparison. We shall see. — *J. B. C.*

#### NORTH AMERICA.

*Jussieuia grandiflora*. — Dr. Samuel A. Cartwright of Natchez, Mississippi State, read a lecture before the Lyceum of that city, in 1839, on the health-preserving property of the jussieuia. It is found on the stagnant waters of Lower Louisiana in great quantities, floating on the surface; and where it appears the water is more or less clear, in proportion to the greater or less quantity of the plant. Dr. Cartwright thinks that the pores of the plant constitute the alembic through which the impurities of the water pass off. The plant bears a flower 3 or 4 feet above the surface of the water; the root is several feet in length, lies horizontally in the water, about 2 in. below the surface; and, with the leaves, forms such a dense covering to the water, as to constitute a bridge sufficiently strong to enable snakes and the smaller animals to pass over the pools in which it grows. Dr. Cartwright thinks that the growth of this plant is conducive to the health of the region in which it abounds, by purifying the water in which it grows; for, though he visited the region to which the plant is indigenous in the hottest season of the year, he found the stagnant waters of the lakes and bayons, which were covered by the plant, as pure to the sight and taste as if it had just fallen from the clouds. South of the district where the plant grows, stagnant pools and bayons become very impure, and he therefore infers that it consumes or feeds upon those substances which, in other situations, corrupt and vitiate stagnant waters in warm climates. In proof of his theory, he adduces another fact, viz. the salubrity of the region in which the plant abounds, notwithstanding that it contains more stagnant water and swamps than any other inhabited district of the same extent in the United States. The health of the people is even remarkable. The growth of the plant is bounded by the 30th degree of north latitude, and the soil and face of the country on both sides of it are similar, viz. alluvial, and containing lakes, swamps, and stagnant water, and covered with nearly the same vegetable productions. The country north is unhealthy, its stagnant waters impure, and life of short duration. On the south side, the atmosphere is wholesome, the water pure, and, as just said, the people healthy. In the country on Bayou Lafourche, where the plant grows, a great number of the original settlers were living, who migrated from Nova Scotia before the American revolution. The negro population is very numerous and remarkably long-lived, many living beyond the age of 100 years. I had the pleasure to see Dr. Cartwright in this city two months since, when he confirmed to me the fact of the health-preserving quality of the jussieuia, by the relation of two cases, the particulars of which I will procure and send to you. — *J. M. Philadelphia, Nov. 27. 1840.*

---

#### ART. III. Domestic Notices.

##### ENGLAND.

*CEREUS Northumberlândia and Cypèrus longus*. — I have enclosed you the account of the cactus I mentioned to you. It was brought home by Mr. Nightingale from Tobago, and bears a very large white flower. I should like it named after His Grace the Duke of Northumberland. Would *Cereus Northumberlândia* do? [According to the received rules, *C. Northumberlândiana* would be preferable. See Lindley's *Introduction to Botany*, 3d ed.,

p. 532.] I named to you that one of the scarcest plants ever found in this country was found in one of my meadows at Boyton, viz. *Cypèrus longus*. Mr. Peat had not been but a very few hours with me at Boyton when he made the discovery. Strange to say, I never noticed it till then, although the meadow is within 500 yards of the house, in a piece of three quarters of an acre, divided from east to west by a small water ditch. On the south side of the meadow there is not a root to be seen, but on the side which is sloping and facing the south, behind which there is an artificial water course filled two or three times a year for the watering of the meadows, it grows in great abundance. The *Cypèrus longus* grows in great abundance there. If you look into Withering's *British Botany*, p. 911., you will see how few habitats there are, and those doubtful.—*A. B. Lambert. Dec. 14. 1840.*

The following are the dimensions of the cereus referred to by Mr. Lambert, as given to that gentleman by His Grace the Duke of Northumberland: height 22 ft., circumference at the bottom 3 ft. 3 in., circumference in the middle 2 ft., circumference at the top 1 ft. 4 in.—*N. Syon, July 2. 1840.*

*Cnicus tuberosus* Willd. was discovered by Mr. Lambert in one of his woods, growing plentifully in one spot only, to wit, in the wood called Great Ridge, between Boyton Wood and South Hill, Wilts. (Withering's *Botany*, p. 911.) The Boyton habitat of *Cypèrus longus* is, we believe, now published for the first time.—*Cond.*

---

#### ART. IV. *Retrospective Criticism.*

*ERRATUM.*—Page 47., line 19. from the top, for “branches” read “bunches.”

*Chatsworth Conservatory.*—In the last Number of the *Gardener's Magazine* (p. 41.), a correspondent, under the initials H. B., in speaking of the great conservatory here, says, “It seems very ill built, and of very inferior materials both wood and glass.” Now, this is not the fact, and the individual in question cannot possibly be a practical man, for both the material and workmanship are universally allowed to be of the very best description, and they have not been equalled in any building of the kind, either large or small. No expense has been spared in procuring the best materials and the best workmen from every part of the country; therefore H. B. has unwisely suffered himself to remark on a subject which, it is evident to those conversant with the principles of construction, he did not understand.—*John Robertson. Chatsworth, Jan. 13. 1841.*

*The Pleasure Grounds at Theobalds.*—I am pleased to see among your “Notes on Country Seats and Gardens,” given in the *Gard. Mag.* for Nov. 1840, that of Theobalds, near Cheshunt. Several years since, I had some thoughts of giving you a sketch of the above place for the Magazine; but the ornamental part of the grounds being only a narrow strip, I thought it would scarcely have proved acceptable, and therefore declined it. I am led to suppose that Mr. Scott, who was Mr. Wingfield's gardener, must have left the place at the time you were there, as otherwise I think he would have told you who laid out the grounds. [We went over them with a gentleman who is the present occupier, G. H. Heppel, Esq.] When Mr. Wingfield took Theobalds, the whole of the place, including the house, was in a most dilapidated state, and he then kindly employed me to lay out the gardens, and to make such alterations as I thought necessary, in order to give the place as much variety as its limited space would admit of, in the accomplishment of which no expense was spared in bringing it to the state in which you saw it. However, in thus claiming the outline as it regards the walks, clumps, &c., and also the selection of shrubs for planting, I must not detract from Mr. Wingfield the degree of merit due to him afterwards in carrying out more fully his plans for embellishment, in which he succeeded admirably; especially as it regards planting the irregular line of light trees and shrubs along the margin of the walks in the front lawn, and planting, lopping, and pruning, both in front and back of the house, in order to bring to view desirable objects,

and to exclude others which were to him objectionable, in which he displayed very considerable taste, and with great effect. Mrs. Wingfield also, in the floral department, exhibited great taste in the selection of appropriate kinds of flowers for furnishing the clumps, and it was at her suggestion that the arches of trelliswork were placed over the straight walk in the back lawn. — *T. Rutgers*. 71. *Navy Row, Devonport, Nov. 19. 1840.*

*On the Natural Succession of Forest Trees in the United States.*—In Vol. V. p. 421. is a short paper of mine on this subject, and I am now enabled to add another fact, in confirmation of those there stated, and from the best authority.

The Rev. Dr. Dwight, formerly President of Yale College, Connecticut, says, that in Addison County, Vermont, the lands which have been once cultivated, and again permitted to lie waste for several years, yield a rich and fine growth of hickory. Of this wood there is not a single tree in any original forest within fifty miles of the spot. The native growth here is pine, of which he did not see a single stem in a whole grove of hickory. Similar specimens of an entire change in the forest vegetation are common in many, perhaps in all parts of New England, where the land has been cultivated, and again covered with wood. — *J. M. Philadelphia, Oct. 30.*

*American Button Wood, or Plane Tree (Platanus occidentalis).*—In the *Prize Essays and Transactions of the Highland Society of Scotland*, vol. v. p. 322., the Rev. G. J. Hamilton states that a severe frost in June 1809 destroyed most of the largest American planes in England, and particularly in the neighbourhood of London, while the Asiatic kinds escaped without injury, a sufficient proof of their comparative hardiness. Granting the fact, I wish to know the reason of the same species of trees surviving the exposure to a cold for many days below 0 of Fahrenheit's scale, and for months below the freezing point. I never heard of any button wood sustaining injury from even the cold of Canada. The tree is one of the most thrifty, and its form of great beauty: the twisting of its branches, noticed in the *Arboretum Britannicum*, vol. iii. p. 2047., is by no means common, and only occurs in a few of the lower limbs. The cabinetmakers prize the wood for bedstead posts and frames. Your account of the Platanus is highly interesting, but I need not select that tree for the remark, for it applies to the whole work, of which the article forms a part. No book in the English language, on any art or science, affords me so much pleasure in reading as the *Arboretum*. Long may you live to enjoy the honour of your useful labour! — *J. M. Philadelphia, Oct. 1840.*

*The Orange Groves of East Florida.* (Vol. for 1840, p. 660.)—By some strange inadvertence, Mr. Gordon, in the article referred to, has spoken of these groves as if they were natural; an obvious mistake, which we take blame to ourselves for not noticing in the same Number in which Mr. Gordon's article was published. Mr. Gordon has, no doubt, fallen into this mistake, from the fact, well known to all botanical travellers in East Florida, of several varieties of the orange being so common in some parts of that country, as to sow themselves and appear like natives. We by no means wish to screen ourselves, however, in this case or any other, from whatever blame may attach to us, and therefore we gladly make this correction; but, in order that Mr. Gordon may have an opportunity of explaining himself, we quote the passage in which this error is referred to in the *Gardener's Chronicle*, No. 3.

“We have not a much better book than Loudon's *Gardener's Magazine*: yet the blunders in it, of which the worthy editor seems quite unconscious, are astounding. In one of his last Numbers he allows a Mr. Alexander Gordon to assert that there are natural orange groves all over East Florida, though every body knows that the orange is wild only in the temperate parts of Eastern and Central Asia. This same gentleman even talks of the wild or native orange having been used as a stock for the finer kinds of that fruit.” (*Crito in Gardener's Chronicle*, Jan. 16., p. 37.)

*Quercus virens, Phellos, and pubescens, and Ulmus effusa.* In the same publication, and immediately following the passage just quoted, is the follow-

ing. "There is a Mr. Main, who publishes a list of British forest trees, among which he includes *Quercus virens* and *Phellos*, two American species, of which the former is unknown as a forest tree, and never can become so, on account of its tenderness, and the latter is hardly more common. The same author, who writes specially on forest trees, tells us that our durmast oak is *Quercus pubescens*, a species only known in a wild state in the South of Europe; and he includes in his list of elms the Continental *Ulmus effusa*, of which he cannot point out a single specimen in the country, unless in some botanic garden." (*Ibid.*) From the manner in which this passage follows the former, the reader would naturally suppose that the list of forest trees referred to is in the *Gardener's Magazine*, and that the error is one of "the astounding blunders" unnoticed by the editor of that periodical. But this is not the case. The list referred to is published at the end of *The Forest Planter's and Pruner's Assistant, &c.*, by Mr. Main, published in 1839, and reviewed by us in the *Gardener's Magazine* for that year, p. 467. Mr. Main's work was also reviewed in the *Athenæum*, and that review of it was noticed by Mr. Main in an article in the *Gardener's Magazine* for 1840, p. 517. — *Cond.*

*Calling of the Queen Bee.* — In a former communication on the queen bee that leaves the hive with the first swarm (Vol. for 1839, p. 605.), I noticed some remarks by Dr. Dunbar on my previous paper on the Calling of the Queen Bee (Vol. for 1839, p. 150.); which, I find, has elicited some observations from that gentleman in your Number for last March. He there kindly offers to set me right where he considers that I am mistaken; and points out some errors which had crept into my communication. I should have noticed Dr. Dunbar's last article earlier, but that I thought it desirable to wait till the swarming season had passed, that I might acquire more experimental knowledge on the subject. The result is, that I find what I advanced correct, namely, that after-swarming does not take place till more than one queen has come forth; of which the proof will appear as I proceed.

The first thing I have to notice is a statement by Dr. Dunbar, that I take credit for the discovery of a fact which even Huber had overlooked, the reason why there is no calling of the queen bees before the first swarm. Whether I can claim such credit or not, is not for me to determine. I will merely repeat what I said on that curious point at p. 605., Number for November 1839, and what Dr. Dunbar says upon it at p. 151., Number for March 1839, and leave the reader to judge which account is more satisfactory. The following were my words: —

"I stated my inability to account for their silence before the first swarm, except upon the supposition that the old queen went off with it eight or ten minutes (minutes is an error in printing; in the manuscript it read days) before her successors left their cells. This having been ascertained to be the case, the silence is so easily accounted for, that it appears strange that the inference should have been overlooked by the most able apiarians, especially Huber, who was well acquainted with the train of facts that led to it. It is clear that the old queen is impelled by instinct to quit the hive with the first swarm, a few days before the young queens are hatched; and consequently before any rival appears in the field to dispute her sovereignty. This is not the case with her successors: the first who is hatched, and from whom the stronger sound of 'peep, peep,' proceeds, makes her appearance before her rivals, who are still in their cells, nevertheless sufficiently forced to utter the weaker call of 'off, off,' &c.

Dr. Dunbar says: — "Were I asked how it happens that the piping is not heard before the first swarm, I should be at a loss to give a satisfactory reason. There are many facts in the natural history of the bee, as in that of other animals, which we can attest the existence of, without being able to give the *ratio quare*. This, perhaps, is one of them; and we are just cutting the knot which we cannot untie, by saying that Nature has so willed it; but of the secret means she employs to induce the old queen to leave her abode, without having recourse to the same violence towards her successors, as

these last offer to theirs, even Huber acknowledges we must confess our ignorance."

I had spoken of Dr. Dunbar's "doubtful quotations from Huber." But he says, that, strictly speaking, he has made no quotations from Huber. But some of his remarks, though not exactly quotations, are so evidently borrowed from that writer, that they may fairly be considered as quotations; for instance, where Dr. Dunbar says that the young queens go quietly abroad in search of males. This accords precisely with Huber's assertion, that impregnation takes place in the air, a thing extremely doubtful. Even that observation which Dr. Dunbar professedly takes from Huber, is not very clear; namely, that "as to the secret means nature employs to induce the old queen to leave her abode without having recourse to the same violence towards her successors as these last offer to theirs, even Huber acknowledges we must confess our ignorance." By this one might be led to think that the old queen never does violently attack her rivals. But this is not always the case; for in one of my hives, this season, the old queen delayed coming forth, and the same piping and rivalry commenced as in an after-swarm.

I may here observe that, when no swarm is meditated, the destruction of young queens commences the same under the sway of a young queen as under an old one. But Dr. Dunbar intimates (p. 151.) that the virgin queens have not full sway, nor are permitted to kill their rivals, till they have been successful in their adventures abroad in search of males. This appears strangely irreconcilable with facts; for it often happens that a swarm leaves the hive in the afternoon, and before morning the young queens are cast out, and even in a grub state. In such cases, the young queens must have been expert indeed to find drones, when it was past their usual time to be abroad.

I have next to notice an error in my article, upon which Dr. Dunbar remarks that he did not state that the "queen, hearing her rivals in their cells, attacks them;" for he knew she would attack them whether they cried or not: but that he does say that "she leaves the hive before any of her rivals come forth;" in opposition to my assertion that "this is certainly not the case, as there are frequently several queens in an after-swarm." Though I was wrong in stating what Dr. Dunbar disavows, the subject in dispute is not affected by my mistake; for the queens certainly do hear their rivals in their cells before they attack them. I know this, from the fact of my having this season cut out a cell while the queen within it was calling. The cell was firmly sealed, so that no attacks from the irritated queen could have caused the one in the cell to cry "off, off!" This convinced me that the piping of queens commences before rivalry.

But I still maintain that no after-swarm comes off till more than one queen is in the field. In proof, I may mention that this season I observed, just when a second swarm was making its exit, two queens fighting at the entrance of the hive, as if disputing which should quit. They both went back into the hive, and the bees also reentered. Shortly after, the bees came out again, and the two queens again appeared fighting as before. At last one mingled with the swarm, and the other returned into the hive.

In another hive, when a swarm was coming forth, a young queen came out, appeared very weak, and dropped on the ground. Shortly after a stronger one appeared, and went off with the swarm. In both these cases, queens had come forth before the swarming, and in the first there was rivalry also; which is in direct opposition to Dr. Dunbar's assertion that the queen "leaves the hive before any of her rivals come forth." What I have here remarked from actual observation agrees with Huber's statement, that a certain degree of tumult commences as soon as the young queens are hatched, and begin to traverse the hive.

The way in which Dr. Dunbar accounts for more than one queen being sometimes found in an after-swarm, namely, that "they take advantage of the confusion caused by the mass of bees, including their guards, following the departed queen, to escape from their cells, and mingle with the crowd

rushing out," appears to me a weak surmise, devoid of any real foundation. For it happens very frequently that more queens than one are found in after-swarms; and it is highly improbable that the newly hatched queens would follow one in the swarm who had been their persecutor, unless driven out by another queen who remained supreme in the hive. Whether queens go off by seniority, as Dr. Dunbar supposes, I cannot say; though I believe that one is supreme when a swarm takes its departure, and that she drives out all that are hatched: and I think this accounts for the irregular manner of after-swarms better than Dr. Dunbar's theory.

It only remains to notice two more assertions of Dr. Dunbar: first, that the old queen is not fiercely disposed towards her successors: and, secondly, that swarming takes place in consequence of the queens going abroad in search of males. On the first, I must refer to the observations already made in the present letter; and as to the second, though Dr. Dunbar says it is a notion which he never before heard broached, it is nevertheless the belief of some. Mr. Taylor mentions it in his *Beekeeper's Manual*; and it would follow much more naturally from Dr. Dunbar's system than from mine, for I have very little faith in the asserted pursuit after drones. When Huber advanced it, he probably acted like other scientific men, who are very apt to dignify their speculations with the name of facts. It is not unlikely that Huber argued from the analogy of moths and other insects, which however do not congregate in nests like bees.

In conclusion, I leave these remarks to the judgment of your impartial readers, hoping that as none of them were meant, so none may be taken, as personal. My only object has been my own just and moderate defence; and the elucidation of a subject highly curious and interesting, though very little understood.—*John Wighton. Cossey Hall Gardens, Sept. 23. 1840.*

---

#### ART. V. *Queries and Answers.*

*To protect Forest Trees from the Ravages of Hares and Rabbits.*—I should esteem it a great favour, if you, or any of your readers, would inform me, through the pages of your Magazine, of any method for protecting forest trees from the ravages of hares and rabbits. I have a great number of young trees under my charge. Last season I suffered very severely from these animals, and this season they have again commenced their annual attack. I have tried several things recommended by the correspondents of your Magazine, but not one of them has had the desired effect.—*James Kingston. Saltmarsh, near Howden, Yorkshire.*

Since this was in type, a gardener informs us that an ointment composed of powdered aloes and hog's lard, brushed over the stems of the trees, will prove an effectual remedy.—*Cond.*

*The Curl in the Leaves of Vines.*—A Subscriber, Knightsbridge (Vol. VI. 2d series, p. 568.), cannot do better than paint his vines over with clay, adding, if he chooses, a little soft soap and sulphur. The use of such an operation is, to destroy or prevent the hatching of the ova of insects. Where no red spider, &c., have appeared during the previous season, there is not much occasion for performing the operation at all; but, as timely prevention is better than a late cure, it is advisable to rub the stems and vines with something, and I have found nothing better and cheaper than the above, which remains a long time on the vines, and helps to keep the stems in a moist genial state.—*Robert Fish. Putteridge Bury, Jan. 11. 1841.*

---



THE  
GARDENER'S MAGAZINE,  
MARCH, 1841.

---

ORIGINAL COMMUNICATIONS.

ART. I. *Observations on Liebig's "Organic Chemistry."*  
By R. LYMBURN.

IN the treatise lately produced by Professor Liebig, at the instance of the British Association, on Organic Chemistry applied to Agriculture and Physiology; he states his opinion that sound principles will not be obtained in the art of cultivation, till physiologists, chemists, and *practical men*, unite their efforts in a mutual endeavour to elicit information. Impressed with the justness of these statements, I propose in the present Essay to go through the different subjects treated of in the work, and make what remarks thereon have occurred to me in my practice. The truths brought forward by the learned professor are profound, and deeply interesting; the inferences drawn therefrom are very startling, and, if true to their utmost extent, must produce a great revolution in practice. The subject is as yet full of difficulties.

It has been attempted, by analysing soils and manures and the constituents of plants, and by submitting plants and parts of plants to forced experiments, to arrive at some definite conclusions. We cannot, however, fully rely on the results produced by pieces of plants, or even whole plants, in forced circumstances. The products of a plant torn up from the soil in which it grew, and its leaves enclosed in the confined air of a glass vessel, may be very different from what would have been furnished in natural circumstances, could the products have been properly collected. It is yet uncertain what is the true action of the fibres of the roots on their food: they seem to assist in decomposition, as well as absorption, but how is not yet certain. The circumstance of two pots of charcoal equally watered and heated through the summer, the one containing a growing plant suffering a greater decomposition of the charcoal than the other, as lately stated by Dr. Lindley, should be decisive of this question: the roots may, however, partly act by removing the atmosphere of carbonic acid formed around the pieces of charcoal; and thus renewing the oxygen to hasten

decomposition. The analysis of the minerals the debris of which constitute the soil in which plants grow has produced various results. Mica, the remains of which enter into most soils, is by some mineralogists said to contain as high as 10 per cent of potash, a very important substance in soils; while others allow it very little, if any at all. Feldspar, the most generally allowed source of potash, is also exceedingly variable. The analysis of organic substances, from their complicated nature, is much more difficult. Very different statements have been given of the results of experiments, from the circumstances under which they have been conducted; and in the analysis of manures we are still very much at a loss. The analysis of the urine of the cow, by Brande, in Sir H. Davy's *Agricultural Chemistry*, gives 40 parts of urea, its most essential constituent, in the 1000; while that of the horse, (both herbivorous animals,) by Fourcroy and Vauquelin, gives only 7. It becomes practical men, therefore, while they receive the statements of such high authorities with the deference which is undoubtedly their due, to put them to the test of reiterated experiment, in different soils, seasons, and situations; and fully to investigate every doubt, before receiving them as *principles* in the art of cultivation; they may be truths, yet other truths may prevent their being Rules.

The first part of the work before us is devoted to the examination of the matters which supply the nutriment of plants, and the changes which they undergo in the living organism; the second treats of the chemical processes after death, of fermentation, putrefaction, and decay. The different parts of plants are shown to consist principally of carbon, hydrogen, and oxygen. Woody fibre, starch, sugar, and mucilage, which form the principal and most abundant proportions of all plants, contain the oxygen and hydrogen in the proportions necessary to form water; the vegetable acids, as the carbonic, citric, tartaric, &c., contain an excess of oxygen; and the vegetable oils, wax, resins, &c., contain an excess of hydrogen, though some of them, as tannin, &c., have acid characters. The juices contain acids united to the metallic oxides or alkalis, as carbonates of potash, soda, &c. Nitrogen, or azote, is an element of albumen and gluten; it is also, he says, a constituent of the acids, and of what he terms the indifferent substances of plants, and organic bases. Estimated by its proportional weight, he says, nitrogen forms only a very small part of plants, but is never entirely absent from any portion of them; even when it does not enter into the composition of a particular organ, it is always to be found in the fluids which pervade it. The essentials to vegetable life are, therefore, oxygen, hydrogen, carbon, and nitrogen. The food must consist of substances yielding these: and, as water furnishes the first two, the carbon and nitrogen, or substances yielding these, are the

principal requisites; together with a soil to furnish the inorganic matters, as alkalies or metallic oxides, which are likewise essential.

On the subject of the *Assimilation of Carbon*, or the manner in which carbon is added to plants, the views of this writer are different from those of most preceding writers. At p. 19. he goes so far as to say that the carbon of plants is derived *exclusively* from the atmosphere; though this must be qualified by his subsequent statements, when considering the action of humus, &c., where he allows of its being partly taken up by the roots. He says, the idea of its being principally taken up by the roots is chiefly maintained by vegetable physiologists: but the observations of Sir Humphry Davy, in his *Agricultural Chemistry*, would lead us to believe he was of that opinion. More lately, Dr. Madden, in his valuable papers on the Action of Manures, inserted last year in the *Quarterly Journal of Agriculture*, seems also to imagine that it is principally by the roots. The opinions of Dr. Lindley, and other celebrated physiologists, are not exclusively for the absorption by the roots; they admit that it is also imbibed by the leaves, but principally by the roots. Amongst these conflicting opinions, it will be well for practical men to have recourse to the work itself for a full account of Dr. Liebig's proofs, which no limited essay can furnish, and carefully weigh them in their minds, and put them to the test of experiment.

He begins by stating the opinion prevailing at present, that humin, or coal of humus, and humic acid, are the sources of carbon to the roots. The humic acid is sparingly soluble in alkalies, or by itself, 1 part in 2,500; the humin insoluble. In the state of humin or humus, the form, he says, in which it exists in the soil, it does not yield the smallest nourishment to plants; and adherence to the above incorrect opinion has been the source of much error. He quotes the opinion of Sprengel, who says that vegetable physiologists agree in supposing humus to be absorbed by roots, by the aid of water; while chemists have observed that humic acid is only soluble in alkalies when newly precipitated, and becomes insoluble when dried, or exposed to cold at freezing temperature. He does not say whether it regains its solubility by heat and moisture; I think it would. These facts, he says, have not escaped the observation of physiologists; and they have assumed that lime, and the alkalies found in the ashes of vegetables, render the humic acid soluble, and fit it for the process of assimilation. Taking this for granted, he states the quantity of ashes and alkalies found in dry fir wood by M. Berthier, and the quantity of dry fir wood stated to be produced annually on a stated quantity of ground by Dr. Heyer; also the estimates of Malagutti and Sprengel, of the quantities of humic acid which combine with the alkalies. From all these data he

calculates that only 61 lb. of humic acid would be taken up by the alkalies; which, at 58 per cent of carbon in humic acid, and 38 per cent of carbon in wood, is equal to 91 lb. of wood that would be produced in 40,000 square feet, in place of 2,650 lb., Dr. Heyer's quantity. As qualifications however of this proof, it may be stated, that the analysis is of dry fir wood; and, by his own statement at page 108., the leaves and bark, and small branches, contain the greatest part of the alkalies in trees. The leaves of firs he states as containing 8 per cent of alkalies; and, if these are neglected in the analysis of the wood, as it appears they have been, it would make a very material difference in the estimate.

He also states that it has been taken for granted, in these calculations, that the alkalies which served to introduce the humic acid into the plants do not return to the soil, since it is certain that alkalies remain fixed in the parts newly formed during the period of growth. On this head it may be observed, that, though alkalies are found forming part of the plant, and therefore necessary to their existence, yet, as stated at page 104., they will certainly be rejected as excrements when not needed, as all articles not necessary are. At page 102. he says, the elements of substances may be retained, and the rest returned; and, at page 156., from the decreasing quantity of ashes found by De Saussure in the analysis of wheat, as it continued to ripen, it appears evident they are so returned. All the alkalies and other matters in excess will be so returned as excrement; and humate of lime or carbonate of potash may be separated into their elements in the plant, the carbonic acid retained, and the lime and potash returned, to be again neutralised and absorbed. He next calculates the quantity of humic acid that would be taken up by rain water, on 40,000 square feet; and, estimating the water at 700,000 lb. of rain, from April to July inclusive, and the humic acid being soluble only in 2,500 times its weight of water, though the whole of the water should be taken up by the plants on the soil, there would not be assimilated above 300 lb. of carbon by this means.

He next calculates the quantity of carbon produced from the growth of different plants in the same quantity of ground; which he estimates at 1,007 lb. of carbon for wood and meadow land, 936 lb. for beet root, and 1,020 lb. for corn: thus showing that neither alkalies nor rain water can render soluble a sufficient quantity of humic acid, to furnish the quantity of carbon requisite. If, however, we allow that the neutral salts are taken up by the roots; if the carbonates of potash, soda, &c., formed in the manure and in the soil, are taken up, the carbonic acid (which has, in some cases, the property of uniting with the bases in two or three proportions,) extracted

from them, and the bases of potash, &c., returned to the earth, to be again neutralised and taken up, which does not seem at all improbable; we may thus greatly augment the quantity of carbon absorbed by the roots.

Besides, it does not appear how we should be solely confined to the action of humic acid, for the production of carbon. Dr. Thomson, who gave it the name of ulmic acid, having extracted it from exudations of the elm, says that moss water is composed of humic acid and water; and yet we have never heard of any great results from moss water. The same authority states that the experiments of Mr. Cavendish proved that water is capable of absorbing 107 volumes of carbonic acid gas, to every 100 volumes of water, at the ordinary pressure of the air; and the capability is increased very much when further pressure takes place. All water running in the earth contains it; it is the carbonic acid which bubbles, and gives the brisk flavour to spring water. I cannot, therefore, see what is the cause that would prevent water saturated with this gas, as it will be in manure, and containing it in large quantity as in rain water, from being absorbed directly by the spongioles of the root. Experiments have been thought to be against this; but the same experiments would be against the absorption by the leaves, as the leaves were sprinkled with water containing carbonic acid, in those experiments, as well as the roots. Dr. Liebig thinks the error was owing to the unnatural circumstances in which the plants were placed, which, I believe, is the truth. The experiments of Sir Humphry Davy and others show that the leaves of growing plants purify air containing carbonic acid, and consequently must have absorbed it. Other experiments, also, of the same philosopher show that, when the beak of a retort containing carbonic acid was introduced amongst the roots of growing grass in the soil, there was an evident and great improvement in the growth of that particular spot in a few days; proving that the gas had been absorbed by the roots. Plants of mint, also, the roots of which he had introduced into water containing charcoal, grew very rapidly; and though no solid charcoal, the test for which the experiment was instituted, was found in the vessels of the plant, yet undoubtedly carbonic acid must have been the cause of the growth being more than usual; the charcoal would give out nothing but carbonic acid, and perhaps a little potash. I have myself often tried the effect of charcoal from wood in hyacinth glasses, and always found the plants more luxuriant than those which got none. I think whoever will be at the trouble of reading the appendix to Dr. Liebig's work, on the experiments extracted from Buchner's *Repertorium*, showing the immense effects produced by growing plants wholly in charcoal with plenty of water, will not fail to be convinced, that the

deep green of the leaves, and great vigour of the plants, must have arisen from the absorption of carbonic acid by the roots, without any help from humus or humic acid.

After producing the negative proofs which we have before stated, of carbon not being derived from the earth by the roots, he proceeds next to state, as positive proofs of its being absorbed by the leaves, that, though plants are continued to be grown on soil, yet the quantity of carbon in the soil augments, in place of diminishing. In forests, where the annual shedding of the leaves causes an accumulation of organic matter, especially where the trees are deciduous, not evergreen which do not shed their leaves so frequently, this will be the case; in the case of scourging crops carried off the land, it must certainly be the reverse, very often at least. It would be difficult to persuade any nurseryman who has taken a heavy scourging crop of old transplanted ash from his ground, or a farmer who has scourged his ground by successive crops of oats, that the ground contains more carbon than when the plants were first put on it. The particular salts necessary to their growth being removed, as he says afterwards, may be partly the cause, but carbon must be removed also, and must be replaced as well as alkalies, though the action of the air will restore carbon sooner than alkalies.

He next states the quantity of oxygen gas consumed daily by men and animals, and by the wood and coal employed as fuel; and notices the fact, that nevertheless the proportion of oxygen in the air never varies, as corroborative of the fact that the leaves give out oxygen. The oxygen consumed by animals and burning fuel is returned to the atmosphere in the form of carbonic acid, which, he thinks, must all be absorbed by the leaves of plants, the carbon fixed in the plant, and the oxygen returned; and as part only of the oxygen is returned, some of the oxygen being also fixed in the plant, as proved by De Saussure, from the added weight being more than the carbon consumed, the consumption of carbonic acid by the leaves must be great. Carbonic acid gas, however, is so much heavier than common air, its specific gravity being 1.5277, that it has a constant tendency to descend; so much so, that, in the caves which contain this gas naturally, a dog will be killed, when a man, from his superior height, may enter with impunity; and thus every shower that falls washes it into the earth, and diminishes the quantity, and so would lead us to infer that plants will get more by the roots than the leaves: the upper strata of air around tall trees should not contain so much, when it varies so much between the height of a dog and man. Lest it should be doubted that the quantity of carbonic acid in the air would be sufficient to supply the leaves with all the carbon, he estimates the quantity in the air from De Saussure at  $\frac{1}{1000}$ th part of its weight; and, if the whole were abs-

tracted from the air every second of time, for 8 hours daily for 200 days, he calculates that 1000 lb. of carbon would be produced on 80,000 square feet. This is only half the quantity formerly estimated as produced by corn, &c., the quantity of land being doubled; he adds, in a note, that lime whitewash has been calculated to absorb, on the surface of walls, nearly three times the quantity. This takes it for granted, however, that the absorption by the leaves is equal to the affinity of lime, deprived of its carbonic acid, for that gas, which is one of the most powerful; and that the air at every second is deprived of the whole of its carbonic acid, and the plants surrounded with a full volume of new air, with its full proportions.

He says, next, that the roots, and other parts of the plant, absorb constantly water and carbonic acid, independent of solar light, which is only needed to assimilate and fix the carbon; and this admission should qualify the declaration of carbonic acid being *exclusively* absorbed by the leaves. In the tropical climates, he says, where vegetation is most active, the air does not contain near so much carbonic acid as in temperate climates; the streams of air which are moved from one climate to another serve to equalise the whole, and the air is thus purified, and its proportion of oxygen, the most essential to the life of animals, kept up. The experiments of De Saussure, he says, have proved that the upper strata of the air contain more carbonic acid than the lower. It was stated to be the case, (De Saussure, Thomson's *Chemistry*,) that the air over the Lake of Geneva contained least carbonic acid, that over the plains at Chamboisy more; in a confined court at Geneva more was contained than on the plain; and rather more in the air of some mountainous places than in that of the plain. It is not stated whether the air from the mountain was from a confined situation or not, that over the sea would be least from the moisture: but, from the specific gravity of the carbonic acid, it must have a base to rest on, whether mountain or plain, and the upper strata of the air cannot generally contain most.

He next says that no matter can be considered nutritious, or necessary to the growth of plants, which possesses a composition either similar to, or identical with, theirs; and that vegetable physiologists have informed us that aqueous solutions of sugar, starch, and gum are imbibed by the roots of plants, and carried to all parts of their structure, but are not assimilated. Where this admission was made it is not said, nor do I ever recollect of seeing it. Sir H. Davy, p. 270. and 271., says that, having used strong solutions of sugar, mucilage, tannin principle, and jelly, he found the plants that imbibed them died; and he was once of opinion these substances were not fit for nutriment, until, suspecting it was owing to the solution being too concentrated, he tried the effects of these solutions, very much diluted, on

plants of mint, which grew luxuriantly. He next watered different spots in a garden with the different solutions separately, and a part with common water; the grass watered with solutions of jelly, sugar, and mucilage grew most vigorously; and even that watered with the solution of tannin principle, the least nutritive of any, grew better than that watered with common water. What is to become of the depositions of these substances laid up as nourishment for the future embryo, in the cotyledons, epicarp, mesocarp, and other coverings of the seeds, in the scales and whole substance of bulbs, and around the buds in trees, if these substances cannot be assimilated by plants? In fact, if these doctrines are true to their utmost extent, practical men would have to learn their business anew: and, if no substances are nutritive for plants till their elements are decomposed out of the plant, and the whole or greater part of the carbon derived from the air; if nitrogen, water, and saline bases, with small quantities of earths and metals, are all that is required from the soil; then, indeed, have we been labouring in vain for so many years, in depositing such quantities of organic remains in the shape of manures. Before receiving these doctrines, however, as principles in our art, we must test them for ourselves; and, while we differ from such high authority with diffidence, we must carefully weigh the reasons brought forward: and, as they cannot be done justice to in an essay like the present, let every one interested, and they are many, have recourse to the work for themselves, and read it over and over again, comparing this work and others on the same subject with their own experience, and the benefits resulting must be more than we can at present contemplate. Many things may occur to a man in his daily practice, which, if known to philosophers, would modify their doctrines very considerably.

He next proceeds to notice the erroneous opinions held by some, that living beings can of themselves produce all the elements required to form their constituents. That all the elements are required, he proves from this fact, that dogs and other animals will die, though fed on the most nutritive food, unless it is varied; and says this is a proof that the experiments of plants attempted to be grown by sprinkling with water and carbonic acid were insufficient, as the nitrogen and other elements necessary were not furnished. The Carrara marble on which they were grown would absorb the carbonic acid, and form supercarbonate of lime; and the sulphate of barytes, and flowers of sulphur, on which also they were grown, were insufficient, as the former from its specific gravity would exclude moisture and air, and the latter would form sulphuric acid with the oxygen of the air: such insufficient experiments are valueless for the decision of any question, till all the requisites



of plants are known and furnished. The Gramíneæ and Equisetáceæ require silicate of potash; the genus *Oxalis*, potash; the *Salsòla* and *Salicòrnia*, common salt. Wheat and other grains require phosphate of magnesia. The roots of *Althæa* contain more phosphate of lime than woody fibre. These are proofs, he says, that all these substances and many others, equally as well as nitrogen and water, are necessary before the plant can be placed in circumstances favourable to its growth.

*On the Origin and Action of Humus.* He defines humus to be woody fibre in a state of decay; and humic acid as a product of the decomposition of humus by alkalies, which does not exist in humus. He also states that woody fibre forms this substance, or humus, by uniting with the oxygen of the air by a process similar to putrefaction, and for which he has invented the name of *Eremacausis*, or tardy combustion; a slow union of oxygen to the woody fibre, which gives off carbonic acid till converted into a brown coaly-looking substance called mould. He describes this humus as existing in soil permeable to the air, surrounded with an atmosphere of its own, of the carbonic acid formed by the absorption of oxygen; this atmosphere around it prevents the further decay of the humus till removed, when a fresh supply of air and oxygen causes a renewal of carbonic acid. This carbonic acid, he says, is taken up by the fibres of the root, and forms for a time the food of the young plant: these fibres he describes as forming, at the same time, mouth, lungs, and stomach to the plant. It has been customary to compare the actions of plants and animals, and it may sometimes help to convey the meaning of the author, but is inapplicable. The food of animals is taken in by the mouth, digested by the stomach, mixed with the bile, and the nutriment absorbed by the lacteals and conveyed to the blood, which is aerated in the lungs. Were we to liken the fibres to mouth, and the leaves to stomach, where are the lungs, and the circulation returning to be aerated? If we say the leaves act both as stomach and lungs, this is a twofold action of which we have no parallel in the animal economy. Perhaps to assume the earth as stomach, the fibres as mouth, and the leaves as lungs, might be nearest the mark; but both order and action are different, and the comparison is, perhaps, of little use. But to return to our subject, the fibres, he says, perform all these offices, till maturity; which he defines as the time when the organs are fit to provide food for themselves from the atmosphere, by the leaves absorbing carbonic acid and dew. Further on he says, a plant gains another mouth and stomach with every new fibre of the root, and every new leaf; and, therefore, we are left to conjecture for ourselves, what is the cause of the new fibres, formed newly every year, ever losing their power of absorption; we

should rather be of opinion that they never will. Were the leaves the sole collectors of food at an advanced age of the plant, whence does it arise that an old tree grows in so excessively vigorous a manner the first year after being cut over by the ground, when there is nothing but roots to feed it. The sugar and mucilage formed in the seeds, he also says, disappear during the development of the young shoots; and this I should think soluble matter assimilated and rendered nutritive. This action, he says, continues, and woody fibre is formed, leaves and nourishment accumulate, till blossoms and fruit are produced by the excess; this he considers as a more compound transformation, and illustrates his meaning by the instance of the double elective affinity produced by the action of hydrocyanic acid and water. It is probable that some very complicated chemical process is at work in the production of blossom and fruit: but that excess of nourishment is not the cause is a fact well known to most practical gardeners, who, when they want fruit, give less food, not more; the more vigorous the growth of the tree they know they will be obliged to wait the longer for fruit, unless they proceed to mutilate the roots or branches. If the plant be in a pit, they stint by giving less water and less room; if in the ground, they cut some of the main roots, or depress or ring the branches.

The action of light and heat on the sap in leaves is required to produce in it a proper proportion of the elements necessary to form flowers. If the sap is in great abundance, the ordinary action of the leaves is not sufficient to produce this proportion; but when the proportion of leaves to sap is greater, by lessening the quantity of sap, which has the same effect as the extended stem and numerous arms and leaves of an old tree, to which the soil cannot send a proportional quantity of food; when, by age or art, the quantity of sap is properly proportioned to the action of the leaves; that action is sufficient to produce the proper proportion of the elements, and fruit is produced. A warm summer in which there is much light and heat, or rather the autumn, or a difference in climate, will produce the same effect, and *vice versâ*. Whether it is the action of this concentrated sap on the organs that stimulates them to produce flowers in place of leaves, or whether it is the presence of proper food that enables the living power to form new organs, the present state of our knowledge does not enable us to say; analysis of the sap around flower-buds, and of the parts of flowers themselves, might lead to some farther knowledge on this point. It appears that the flower-bud, though formed, can be changed, the pistils and stamens into petals, and the whole made to return again to the form of leaves, by enriching the soil and furnishing a greater quantity of soluble food, as is the practice

with the best growers of double stocks, who first impoverish and then enrich the plant. It would thus appear, that the quality of the food can transform the one organ into the other, and that they are convertible, not different; the greater the quantity of food, the lower in the scale of organisation is the product, as it is necessarily more crude. Fruit trees never bear well when the vigour of their growth is excessive.

He next continues to explain various actions that take place, as the power of malt to form sugar from starch by the fermenting principle; and contends thence, that the power to effect transformations does not belong to the vital principle, but is purely chemical. The process, no doubt, takes place in another form more complicated; but he thinks it still possible to be discovered. He speaks afterwards of the vital principle balancing the chemical, and the excess of food to animals causing the chemical force to predominate, and produce disease: in a similar manner will the excess of food in plants produce disease, though disease may arise, as in animals, from other causes. After death, in plants, the chemical force prevails, and dissolution takes place, though more slowly than in animals. He complains that the term vital principle is applied to every action we do not understand, as the terms specific and dynamic in medicine; and that we should not be deterred from examining into actions by these names. It will, perhaps, be long before we can give any other name than that of a principle we cannot understand, to such actions as the transformation of leaf-bud into flower-bud, or the formation of the leaf-bud, itself the rudiments of a future branch. Will any chemical compound we can produce generate these or any vegetable organ, with their infinite modifications? And, though we could point out what transformations are made, we might still be ignorant of the power that produced them. While the blossoms are being formed, he says, secretions are more abundant, and excretions, also, of carbon and other matters.

He next considers the fact, that distilled water and carbon will not make a plant thrive well, and that rain water is necessary; the rain water containing a compound furnishing nitrogen, one of the essentials of vegetable life, which, with hydrogen, forms ammonia.

*On the Assimilation of Hydrogen*, the next division of the subject, he says, when hydrogen is fixed in the wood, the oxygen set free is the same, whether we consider it to be produced by the decomposition of the carbonic acid or water, but he thinks it most probably the latter. The oxygen of the water being set free is assimilated as oxygen, the oxygen of the carbonic acid returned to the air; which he estimates at the rate of 2,600 lbs. of oxygen to be set free in the air from each acre of land (the weights and

measures are all Hessian; the proportions are the same, whatever standard is taken). He says that the carbonic acid is in the state of an oxide. Carbonic oxide is only absorbable by water sparingly, estimated from  $\frac{1}{16}$  to  $\frac{1}{50}$  of its volume. Solubility in water is, perhaps, not required by the action of the leaves. From the fact of plants generating caoutchouc, wax, fats, and volatile oils, containing hydrogen in large quantity and no oxygen, we may be certain, he says, that plants decompose water, because from no other body could the hydrogen be obtained; and, though some parts of plants contain the oxygen and hydrogen in the proportions of water, they cannot exist in the plant in the state of water. He then gives an analysis of various substances produced by plants, showing that most oxygen is separated to the air when oils are formed, as less is retained; and in acids the reverse. These vital processes, he says, differ from the chemical formation of salts, being the very reverse; but carbonic acid, zinc, and water, when brought into contact, act upon one another, and separate the hydrogen, perhaps by electric action; the zinc acting so far like the plant. The remainder, however, contains carbonic acid, zinc, and the oxygen of the water, in a white pulverulent compound, but not combined into the form of wood, nor with the oxygen and carbon separated. The carbonic acid separated in the process of decay is most from acid substances; oily have not the same tendency to putrefy, as they want oxygen. The numerous springs which emit carbonic acid in the neighbourhood of extinct volcanoes, he mentions as a great source of carbonic acid. The Eifel, near Coblenz, has been calculated to yield 90,000 lb. daily to the atmosphere, corresponding to 64,800 lb. of pure oxygen, when decomposed by plants.

On the next subject, the *Origin and Assimilation of Nitrogen*, this writer differs from all others, in the prominence he has given to it. Former writers told us that nitrogen existed only in small quantities, most of it in the higher order of plants; and though its necessity was inferred from its presence, yet little comparatively was said about it. Dr. Liebig, however, says, we cannot suppose a plant would attain maturity, even in the richest vegetable mould, without the presence of nitrogen; since we know that nitrogen exists in every part of the vegetable structure: if it is not found in the solids themselves, it is to be found in the fluids that surround them.

On the question, how this nitrogen is obtained, he considers it from ammonia solely, which is a compound of hydrogen and nitrogen. We have not the slightest reason, he says, for believing that the nitrogen of the atmosphere takes part in the processes of assimilation of plants and animals; on the contrary, he says, many plants emit the nitrogen which

they have absorbed, either in the gaseous form, or in solution in water. The quantity of nitrogen in the atmosphere might lead to the supposition that it might be absorbed and assimilated as such. The fact of its being absorbable in water, in small quantities only, is against this; and likewise his finding it in plants in the state of ammonia: unless we suppose that the presence of free hydrogen in the plant, from decomposed water, may enable ammonia to be formed by the action of the living principle; though it can only be formed chemically in a recent state, when the nitrogen is newly separated. May not the salts of nitric acid, also, be another source of nitrogen? The nitric acid requires considerable heat for its formation; and its salts, nitrate of potash (saltpetre) and nitrate of soda, are more plentifully formed in warm countries, as India and Peru, from which they form an article of commerce. But saltpetre is largely formed in France, from beds of animal remains in the open air; and, in certain circumstances, where heat, and lime, and alkalies are present, may not nitrates of potash or soda be formed in our manure heaps? or if nitrate of lime is formed, it is one of the most soluble of all the salts of lime. The salts of nitric acid are now much used as manures; and their only properties, which are said to be great, must be the yielding of nitrogen.

The nitrogen of plants, in the form of ammonia, he thinks, is got from the atmosphere; as, notwithstanding all the nitrogen that is carried off by plants, the new crop of plants still continues to yield nitrogen, which it cannot derive from the soil it exhausts; and the supply of ammonia is principally from the putrefaction of animal bodies emitting nitrogen into the air. It forms carbonate of ammonia with the carbonic acid of the air, and is carried to the earth by rain water, and to the leaves in the form of dew. The reason why analysis has failed to detect ammonia in the air, he says, is from the small quantity generally employed for analysis, as 10 cubic inches, which would yield only  $\cdot 000,000,048$  of a grain; but, if a pound of rain water is examined, it will be found to contain as much of it as 20,800 cubic feet of air. A field of 40,000 square feet, he calculates, will thus receive annually 80 lb. of ammonia, or 65 lb. of nitrogen; calculating 10 lb. of rain water to contain one fourth of a grain of ammonia, and the annual fall at 2,500,000 lb. of rain. This is much more than would be drawn off in the production of the albumen and gluten in wood, hay, or beet root; but less than by the straw, roots, and grain of corn, which would therefore require a change of crop. Nature, he says, produces sufficient nitrogen for wild plants; it is cultivation, or abnormal production, which demands more. Experiments made in the laboratory at Giessen, where he is professor,

have put the presence of ammonia in rain water beyond all doubt; as, when distilled in considerable quantity, sal ammoniac was formed, on the addition of a little muriatic acid. The presence of carbonate of ammonia in rain water shows the benefit of preferring it in watering plants; the more recent the better, as it is a very volatile salt. Water cannot easily be saturated with ammonia. It will contain 468 times its volume when saturated; water from manure will therefore contain a great quantity: it should be washed into the soil to prevent volatilisation. Ammonia may also be detected, he says, in snow water; and the ammonia contained therein has the offensive smell of perspiration and animal excrements; a fact which leaves no doubt of its origin. The quantity of ammonia in a given quantity of rain water will vary according to the quantity of rain; but the quantity of ammonia furnished will not vary much. Any one, he says, may easily test the presence of ammonia in rain water by adding a little sulphuric or muriatic acid to it, and evaporating nearly to dryness in a china basin: the ammonia remains in combination with the acid, and may be detected by the addition of a little powdered lime, which uniting with the acid, the ammonia is separated, and given off with a pungent smell. The ammonia removed from the atmosphere by rain and other causes is replaced by the putrefaction of vegetable substances containing gluten and albumen, and of animal remains and excrements. In the solid excrements there is little, in the urine most. The ammonia, he says, is taken up by the roots, which he seems to think the chief way of their getting ammonia; though I cannot see how the same may not apply to carbon; both ammonia and carbonate of ammonia being of less specific gravity than carbonic acid, and more likely to exist in the upper strata of the air.

Albumen, gluten, quinine, morphia, and cyanogen, with a number of other compounds, are the principal substances in plants, he says, which require nitrogen. The first is to be found in seeds, around buds, &c.; the second is to be found in wheat and other grains, the inner bark of hollies, &c.; the quinine is obtained from Peruvian bark; the morphia from poppies, lettuce, &c.; the cyanogen from daphnes and other plants yielding prussic acid.

The fact of ammonia being contained in the juices of plants was first discovered by Dr. Wilbrand and himself, in 1834, when investigating the quantity of sugar contained in different varieties of maple growing on soils which were not manured. On mixing the juice with lime, ammoniacal fumes were given off, which they at first suspected to be from urine put in the bottles collecting the juice, but were afterwards convinced by the juice being taken from a wood several miles from any house.

Every person, he says, who has entered a manufactory of beet-root sugar, must be astonished at the great quantity of ammonia volatilised with the steam, which is a source of loss of sugar; the escape of ammonia causing the neutral juice to become acid, and the acid changing part of the sugar into crystallisable grape sugar and syrup. Distilled flowers and medicinal extracts contain ammonia. The unripe fruit of the almond and peach, tobacco leaves, the exudations of vines, beet root, unripe blossoms and fruits, the juices of birch, maples, &c., all yield ammonia. He gives an analysis of different kinds of wheat, differing as far as from  $12\frac{1}{2}$  to  $26\frac{1}{2}$  per cent in the gluten they contain; in winter wheat the gluten is only 3.33 per cent.

Animal manure, he says, increases the gluten, as well as the quantity of grain. Wheat grown in a soil manured with cow-dung, which contains little nitrogen, yielded only about 12 per cent of gluten; while that grown in a soil manured with human urine yielded as much as 35 per cent: he does not state the increase of produce. Putrid urine, he says, is best, as the urea in the urine is converted into carbonate of ammonia by the heat and moisture of putrefaction. Guano, the dung of sea-fowls, used as manure in Peru, producing great fertility, is composed of urate, carbonate, &c., of ammonia. Manure acts *only*, he says, by yielding ammonia. That urine is a powerful manure is, in practice, well known; and that ammonia is very needful seems undoubted; but that the ammonia only is useful cannot be said: it is principally in the state of carbonate of ammonia, which contains one atom each of carbonic acid, water, and ammonia. The urine also contains salts of potash, soda, and lime, which he afterwards considers as important; also mucus, and other animal substances. The guano contains excrement, and, analysis says, fatty matter. The salts of nitric acid can give little except the nitrogen and their bases, which may neutralise and absorb carbon and organic matter. If these salts produced fertility in sterile barren sands, then might we see more of the exclusive benefits of nitrogen. Most soils contain much undecomposed organic matter; it is rated very high in fertile soils by Sir H. Davy. Ammonia uncombined has been thought poisonous to plants, as fresh urine and hot dung have been found to kill many plants: perhaps, as it seems to act principally as a stimulant, it may be poisonous only when not diluted with water, which prevents its being in excess, and is well known as a source of safety.

All plants, he says, contain azotised substances, and no animal can live without nitrogen or azote. Horses fed on potatoes get weak, as potatoes contain little nitrogen: rice also contains little; and a much greater quantity of that food is required than wheat. As animals assimilate nitrogen, their

excrements cannot contain as much as they consume, and hence no manure can return to the soil as much as is taken off; it must be got from the atmosphere, from the ammonia emitted by dead animals. The urine of carnivorous animals, he says, will also contain more nitrogen than that of herbivorous; and the urine is the principal source of ammonia. Yet we find the urine of the cow to be a very powerful manure to vines; and the juice of the vine contains a great deal of ammonia. The benzoic acid, a principle in the urine of herbivorous animals, is useful, he says, to some plants, as the sweet vernal grass, which contains that acid.

It is much less the quantity of ammonia, he says, yielded by excrements, than the form, which makes it produce fertility. Carbonate of ammonia is very volatile, and the other salts of ammonia not so much so; and this, he thinks, is the cause of the influence of gypsum (sulphate of lime) on the fertility of grasses. The sulphuric acid of the lime unites to the ammonia, and forms sulphate of ammonia, a salt not so volatile; and preserves the ammonia. The gypsum acts, he says, on the carbonate of ammonia as long as a trace of it exists: 100 lb. of burned sulphate of lime will fix all the ammonia in 6,250 lb. of horses' urine. Taking Boussingault's estimate of  $\frac{1}{100}$  part of nitrogen in grass, every 4 lb. of gypsum would add 100 lb. to the produce. This supposes the produce cannot be made without the nitrogen. In the analysis of the wheats before noticed, it appears plants do not always contain the same proportion of nitrogen to the bulk: the food may be more valuable, but the quantity of nitrogen does not seem to regulate the quantity of produce exactly. Former writers thought the sulphate of lime beneficial to clovers, because it formed a part of clover. Water, he says, is required in great quantity to dissolve the gypsum, in the proportion of 400 parts to 1; and hence the less benefit from gypsum on dry lands. The decomposition of gypsum by carbonate of ammonia proceeds gradually, and will last for years. Gypsum might thus be of use in fixing the volatile carbonate of ammonia in manures and urines. When spread on the ground, however, what will hinder the carbonate of ammonia which has to approach it there, and which is equally soluble, from being taken up as carbonate of ammonia by the roots, adding both carbon and ammonia to the plant. Sulphate of lime is cheap. Chloride of calcium, also, he says, fixes the ammonia. Being generally manufactured from sal ammoniac, it may be high-priced; if it could be got in a cheap way from salt and lime, it would be beneficial. Chloride of lime, Dr. Thomson says, decomposes ammonia. Sulphate of ammonia has been extracted, in a commercial way, from soot, to form sulphate of soda, by subliming



with common salt (chloride of sodium). Burnt clay containing oxide of alumina, and ferruginous soils containing oxide of iron, owe their fertility, he says, to all minerals containing alumina and iron attracting the ammonia from the atmosphere. Oxide of iron emits ammonia in great abundance, and so does pipeclay when moistened with potash. The ammonia absorbed by the clay or ferruginous oxide is again separated, he says, by every shower of rain, and conveyed in solution to the soil. Powdered burnt charcoal, he says, possesses a similar property, and condenses ammonia within its pores. It absorbs 90 times its volume of ammonia; decayed wood, or humus, 72 times its volume.

The humus and charcoal I should think the best substances to absorb ammonia from the atmosphere. Burning of soil is more often found to do harm than good; when it does good, it is ascribed to its altering the mechanical structure of the soil, and making a dense impervious cold clay soil more open and warm. Ferruginous soils, so far from being fertile, I have always heard rated as proverbially sterile. I have, in my practice, seen soils of a very deep red colour with oxide of iron, which, though heavily manured, did not yield a tenth part of the crop of potatoes which was got alongside from soil of a yellow brown loamy colour. The manure was exhausted amongst the oxide of iron; and the potatoes were not above the size of peas. The iron appears to decompose the manures introduced into the soil, from its great affinity for acids; its protoxide combines with most salts, and forms new compounds. The sulphate, one of those compounds likely to be formed when animal remains exist in the manure, is poisonous and soluble. Carbonates of ammonia or potash, or humate of lime, may thus be decomposed, the ammonia set free, and the carbonic acid lost in the form of carbonate of iron. Dr. Thomson says that iron has a great affinity for acids in the state of protoxide; and, when exposed to the air and oxygen after combining, is apt to form peroxides, and lose the acids. Whatever is the reason, the soils abounding in iron are proverbially barren here.

He concludes this article by stating that carbonic acid, water, and ammonia are the elements necessary for the support of animals and vegetables. The innumerable products of vitality resume after their death the original form from which they sprang; and their death, the dissolution of one generation, is the source of life to another. The conditions already considered, however, are not the only ones necessary, he says, for the life of vegetables; and he next proceeds to examine the *inorganic constituents* of plants.

Other substances than carbonic acid, water, and ammonia, he

continues, are requisite for the formation of organs destined for special functions peculiar to each family of plants; these are found in the ashes of incineration, though in a changed state. All substances in solution in a soil are absorbed as a sponge absorbs liquid, without selection he says, those that are wanted retained, and the rest rejected as excrement. Phosphate of magnesia is an invariable constituent of all the seeds of grasses, is contained in the outer horny husk of grain, and introduced into the bread and beer: it is contained in the greatest quantity in bran, and forms often large crystalline concretions in the cœcum of millers' horses; and, when ammonia is mixed with beer, separates as a white precipitate. Most plants, perhaps all, he continues, contain organic acids in combination with bases of potash, soda, lime, magnesia, &c. These bases diminish in fruits, as the acids diminish in ripening; and the quantity is greater in those organs which prepare the food, as in leaves, compared with those where it is assimilated, as in the mass of woody fibre. The potato contains more before blossoming than after it. The fumaric and oxalic acids in liverwort, the roccellic acid in the *Roccella tinctoria*, the tartaric acid in vines, and other peculiar acids formed in peculiar plants, show that they are essential to them. All yield by incineration carbonic acid united to a base, all therefore must contain, he says, salts of *organic* acids; and, as we know the capacity of saturation of acids to be unchanging, hence, on whatever soils plants grow naturally, they must contain an invariable quantity of alkalis, culture alone will cause deviation. The absence of one alkali, he says, is compensated for by another similar in its mode of action; and he shows by analysis, by De Saussure and Berthier, of the ashes of the pine tree from different soils, that, though the quantities of potash, lime, and magnesia varied, yet the quantities of oxygen contained in the amount of the three bases were the same in each; if the magnesia or lime were less, it was made up in the greater quantity of potash or soda. When there was any variation in the quantities, it was found that the bases were in combination with *inorganic* acids, as the sulphuric, phosphoric, &c. These remarkable approximations, he says, cannot be accidental, and, if further analysis confirm them, must show that the bases and acids are always proportional. It is not known, he says, in what form silica, manganese, and oxide of iron are contained in plants; but we are certain that potash, soda, and magnesia can be extracted from all parts of their structure in the form of organic acid salts; and lime, unless when present as insoluble oxalate of lime, as in lichens, and there supplying the place of woody fibre. Even double acid salts, as the tartaric and oxalic (which acts like a double acid), have only one base, and are never quadruple; the capacity of

saturation of an acid is constant. As these acids and bases, and even the form they present themselves in, are not subject to change; it may be affirmed, he says, that they exercise an important influence in the developement of fruits and seeds, and also in many other formations, of the nature of which we are yet ignorant. If the acid is required for the organs, the alkaline base must be present; it may be altered from soda to potash, as in the *Salsòla Kàli*, grown from seeds of plants ripened at a distance from the sea; or the alkali may be lime, but some base must be present. Potatoes grown in cellars without earth furnish a true alkali called solanin, of a very poisonous nature, in the sprouts, which they never do in the fields. This necessity for an alkali, he thinks, shows that alkaline bases are connected with the developement of plants. The meconic acid in poppies is united with the alkaloids narcotina, morphia, codeia, &c.: the bases may vary, but the quantity does not; when there is a deficiency in meconic acid, it is made up by the sulphuric acid, the proportions being always the same.

If inorganic acids, he says, are thus substituted at times for organic, the substitution of the inorganic alkalies for the organic is likely to take place in a much higher degree. When roots find their more appropriate bases or alkalies in sufficient quantity, they will take up less of another. When the soil in which a white hyacinth is growing in flower is sprinkled with the juice of the *Phytolacca decándra*, the blossom, he says, will assume in one or two hours a red colour, which the influence of sunshine will cause to become gradually white again after a few days; the juice will either be excreted entire, or, if any of its elements are nutritious to the plant, the remainder will be separated. Acetate of lead, and nitrate of strontian, absorbed by plants in the experiments of Macaire Prinsep, were returned again by the root as excrement: thus, he says, soil where common salt abounds will return it though absorbed; it will also kill the plant if in excess, and so would acetate of lead.

Firs and pines, he says, have but little alkali in their ashes. Lime trees, rye, and potatoes have much more; and firs will thrive in quantities on barren sandy soils, while wheat and lime trees will not. The spruce fir, however, will not thrive on a dry soil, however alkaline it may be; and the state of moisture of the soil must, therefore, have its share as well as alkalies. All kinds of grasses, and also *Equisetaccæ*, contain a large quantity of silex in the stalks and outer parts of the leaves, in the form of silicic acid, or oxide of silicon (the form silex is generally found in) and potash united, forming silicate of potash. This is mostly returned to the cultivated grasses, in the form of rotted straw, in the manure. In natural meadows, he says, where the hay is taken off, we never find a luxuriant crop of grass on sandy

calcareous soils, which contain little potash, evidently because the potash is not renewed. Soils formed from basalt, grey-wacke, and porphyry are therefore, he says, best for meadow land, on account of the potash they contain, from the reduced feldspar. These soils, however, contain a good deal of alumina, and will not part with their water and organic substances so readily as the sandy soils. Some irrigated meadows in Germany, he says, yield four times as much produce as others not irrigated, and the fertility he attributes to the potash carried on the meadows from the rivers which irrigate. There may however be organic substances deposited as well as potash: humus is light and flocculent, and, if the soils irrigated are sandy, they may be helped by alumina deposited if the rivers pass through clayey soils; part may be owing to these helps, as well as to the potash. The meadows irrigated from the common sewers, in the neighbourhood of Edinburgh, yield more than four times an ordinary produce; it is the excrement deposited that is supposed the cause. The quantity of potash, he says, in soils is inexhaustible, when compared with the quantity removed. If the crop of grass, however, is increased by the gypsum, there is more potash taken off than by a small crop, and it would exhaust the alkalies more; but in Germany they restore the fertility, he says, by sprinkling the field with wood ashes, or the lixiviated ashes of soap-boilers: these last should contain some oil in solution with the ashes. The sandy heath of Luneburg yields a crop only once every thirty or forty years, by burning the heath, which yields the potash, he says, collected by rain water during that time. There should also be charcoal from the wood of the heath, and from the wood ashes above, to produce carbonic acid and ammonia; it, is, perhaps, necessary to notice other benefits as well as the one under review. The most decisive proof, he says, of the want of potash, is that of a man at Bingen, who manured highly with horn shavings, which contain little or no potash, and starved his vines ultimately, though drawing very heavy crops for a while; others who used cow manure, though the crops were not so heavy at first, had continued fruitfulness. A field also which was cropped with wormwood, for the sake of collecting its ashes, was barren for a long time afterwards; and woods where the young branches and leaves were taken off got stunted in their growth, until they were prohibited from being taken away, which restored their luxuriance. These all show forcibly the need of alkalies. I should also ascribe part of the effect, in the first instance, to the vines being allowed to overbear themselves, which in this country is considered to exhaust the strength of the plant; there is a vital power in animals and plants, which all the alkalies and nitrogen in the world will not replace, if it is trenched on, though they

may help to restore it; in the second and fourth, the effects should be partly owing to the other elements of the cow manure and leaves; and in the third, the wormwood might scourge in other respect as well as potash.

Plants do not impoverish soil in the direct ratio of the bulk they produce. Privet and leek, which are very scourging crops, do not produce near so much bulk as poplars and potatoes, which scourge it less; they scourge more in the ratio of the fibres of the root. Some plants seem not to extract so much nourishment from their food, as we find some animals will grow larger on much less food than others; and this also varies with the circumstances, as heat producing activity in the lacteals, leaves, &c.: it is the quantity of food which plants assimilate, not what they absorb, that increases bulk; they will have most excrement that assimilate least. Such things the professor might not think worth noticing when advocating a particular subject, such as this on alkalis; but, when placed together, they help to prevent our going to excess with our inferences from data. Sea plants will grow inland, he continues, if near salt-works; and the urine and bones of men and animals yield the phosphates of lime and magnesia necessary for the grains they cultivate as grasses. Hence, these plants follow human habitations, as some weeds which abound in ammonia are found on dunghills. From these facts he infers that plants will not succeed well, unless the phosphates, &c., needed are present; and these will always produce more fertility than any other manure. In this country, bones have been reckoned more beneficial to turnips than to any other crop; and yet the analysis of turnips by Dr. Madden gives no phosphates at all. Perhaps the animal matters, as gelatine, &c., in the unboiled bone furnish food to the turnip, and the phosphates to the next crop of wheat. There must be some relation between the food and the analysis of the plant, the doctrine of plants producing elements themselves I think untenable; but we have much yet to learn.

From the capability of volatilising borax; from the salt in salt-works being found deposited on glass fixed above the works, in their atmosphere; and from the air over the sea always containing sufficient to render a solution of nitrate of silver turbid; he contends for the salts of plants being carried in the atmosphere. The carbonate of lime in the sea is only one part in 12,400, and yet supplies the myriads of mollusca and corals. The iodine in fuci is collected from sea water, which contains only one part in a million. Hence, the immense effects produced from small quantities; and, though the alkalis are contained in the air in small quantities, great effects may ultimately be produced. The sea water contains more carbonic acid than fresh water, and also contains ammonia. The sea being filled with

plants, they collect alkalies, he says, as well as those of the land. Plants inland collect the alkalies evaporated from the sea in rain water, and from springs that permeate the earth. Were it not for plants, he concludes, alkalies would gradually disappear, though he does not state how; perhaps he means by again forming the earths into stones, the metals do not part with their oxygen readily.

On the next division, the *Art of Culture*, he resumes the consideration of the use of humus; its insolubility, he says, prevents its being carried off from ground, being soluble only when combined with oxygen, and being taken up by water only as carbonic acid. The humus in the soil unites to oxygen, and gives off carbonic acid; which, as before said, stops the further decay of the humus, till the carbonic acid formed is taken off by plants; when a fresh supply of oxygen resumes the action on the humus. He next quotes various places which abound in vegetable remains, and calcareous earth; and, from the fact of no humic acid, or humate of lime, being found in these places, infers its absence in common vegetable mould; it is carbonic acid, not humic, he says, that gives the food to plants. I think it is most likely to be the way, at least for the greatest part. Dr. Madden, on the same subject, says that, though a solution of soil in water will not yield humic acid, yet it will yield it to a solution of salts; and infers that it exists in small quantities, and forms gradually humate of lime: the salts, however, in this experiment, may have acted on the humus, and produced part at least of the humic acid detected. The humus, Dr. Liebig says, if in great quantity, will rob the ground of its oxygen; and he points out some places where parts of meadows are burnt up, and stunted in vegetation, from the great quantity of carbonic acid; so great at times as to be emitted with an explosion, when the ground is bored into. Part of the cause of this ought perhaps also to be ascribed to excess of food, which will kill many plants; but he inclines to refer it solely to the deprivation of oxygen; and illustrates this position by the effects of stagnant water, which having parted with its free oxygen, and being stagnant, and the oxygen consequently not renewed from the air, plants languish and die for want of oxygen when their roots are confined in it. This, I believe, is fully borne out in practice. It has been customary to say that alders, willows, and other plants, will thrive in stagnant water; but I am informed by Mr. Aitken of Lanfine, in this neighbourhood, Newmilns, that the plantations there, which are to a vast extent on moorland, and much of it very marshy, completely refute the common opinion, and show the necessity of oxygen as well as moisture. The alders, willows, poplars, ash, &c., though they require moisture to their roots, will not thrive where it is stagnant; and it is only near the little

streamlets, where motion is kept up in the water, that they will thrive. The tendency of stagnant water to putrescence, and consequently rotting of the roots, will also have its effects. The only plant, he says, that thrives well in their marshy ground, is the spruce fir; it throws out its roots along the surface, where they will be constantly exposed to the air and oxygen, and does not dip the roots into the stagnant water in the soil, as the others do; so much so, that they can be uprooted with very little trouble.

When on the subject of these plantations, I may mention the great effects produced from the warmth and shelter they afford; corroborating the statements on these subjects so forcibly made of late in the *Quarterly Journal of Agriculture*, of the great benefits of sheltering woods in cold bleak situations. Dr. Brown of Lanfine, in an essay lately published on some fossil trees found on his estates, gives it as his opinion, that the climate must once have been many degrees warmer; the cause of the cold he attributes to the removal of the woods once existing. A great quantity of sensible (not latent) heat must have been retained by the vast amount of confined air (which is the best retainer of heat) generated in these woods; the electric conductors formed by the pointed trees would increase these effects; and the mass of heat thus stored up, to be given out slowly when the air was colder than the wood, must have had a great effect on the climate.

Water from barren peat soils, Dr. Liebig says, yields much humic acid; and all agriculturists and gardeners agree, he adds, that manure is not suitable for plants, till it loses the power of giving colour to water. I have seen manure kept for years, the drainings from which were as brown as ever. I never heard the remark made, and imagine the manure would produce little effect if so far decayed. I think, however, there is some mistake about the benefits derived from humic acid; it abounds in moss water, as before quoted from Dr. Thomson, and above from Dr. Liebig; and, from a substance so plentiful, it is wonderful we have not heard of its great effects, accidentally, from practice: perhaps the antiseptic principle of tannin, also contained in the moss water, may help to prevent the small quantity 1 part in 2,500 from taking effect; if it were mixed with quicklime, humate of lime, said to be a more soluble substance, might be formed. Dr. Liebig says the humate of lime is not more soluble than humic acid. Whatever may be the fate of the theory of humic acid, it is, I believe, almost wholly allowed by gardeners, that manure yielding this brown-coloured water is in the fittest condition for plants: they are constantly in the practice of watering with the brown-coloured water, and of extolling its effects. In Holland they are said to wash the dung,

and take the brown-coloured liquid in barrels to the field, in preference to manure. Dr. Thomson says the humate of potash is brown-coloured also and soluble, perhaps this may be formed in the dung: but, from the aptitude of humic acid to be displaced by other acids, I am afraid the carbonic acid may take its place, as it will likely be most plentiful. It appears, also, to be little more soluble than the acid itself (see quotation from Sprengel, p. 8.). I think it most probable that the benefits of manure are more likely to arise from the neutral soluble salts of carbonic acid, as ammonia, potash, soda, &c.; the other salts of ammonia, phosphates, &c.; and the carbonic acid itself in solution, likely saturation, in the water of the manure; as also the other soluble vegetable and animal substances in the heap; than from the small quantity of humic acid found in the water,  $\frac{1}{2300}$  part. Dr. Liebig had before stated (p. 25.) that these soluble vegetable matters could not be assimilated though absorbed; but he states in p. 124, 125. the great quantities of starch deposited in pine trees, and sugar in maple trees, also the starch deposited in potatoes; there are also large deposits of mucilage and albumen. When he considers all these as reduced into gum or mucilage next year, to be assimilated in the young shoots, I cannot see, if the plant can assimilate these, that it will not assimilate also the same substances in solution in the manure, and absorbed by the roots, as Sir Humphry Davy's experiments would lead us to believe. It appears the statements in p. 25. are advanced as the opinions of others more than his own.

He here gives us some elaborate dissertations on the way in which these substances are assimilated, and points out the necessity of nitrogen in forming the principle called diastase, which greatly assists in reducing the starch to gum. The nitrogen absorbed by the roots of plants, in the gluten and albumen of the soluble substances, produces the nitrogen for forming diastase; it is found surrounding all the organs, and hence the great necessity of nitrogen to carry on the assimilation of the food. Unless nitrogen be present, he says, the food will not be assimilated; and people who live on potatoes have more granules of undecomposed starch in their excrement. If there is a deficiency of nitrogen in animals, fat is formed; if in plants, oils, resins, starch, &c.; or these or the food are returned as excrement: the nitrogen itself, if in excess, will also be returned as excrement. The gluten, albumen, and mucilage, he says, contain nitrogen; the sugar, starch, oil, wax, and resins do not; and potatoes or beet have less starch and sugar when animal manures abound in the soil, though the plants are larger. As mucilage is first formed in the potato, which is afterwards ripened into starch, it is probable



part of the functions of the leaves, are to separate nitrogen in the form of ammonia, and this may be part of the effect in proportioning the elements of the sap so as to produce flower buds. The professor's reasonings on the subject of nitrogen are very profound, and in advance, and should be well studied.

The action of light, he says, stimulates the power of the leaves to assimilate, or prepare for assimilation, the food; and presupposes a power and capability in light, to which the most powerful chemical combination cannot be compared. The strongest galvanic battery cannot separate the oxygen from the carbonic acid; and though chlorine, by its affinity for hydrogen, forming muriatic acid, will separate the oxygen from water, under the influence of light, yet it cannot be considered as at all equalling the power and energy with which a leaf separated from a plant, and thus in a mutilated state, decomposes the carbonic acid. De Candolle says, the leaf loses the power of decomposing carbonic acid when the plant dies; a separated leaf should be approaching that state; cuttings and leaves will live some time after separation, but the living powers cannot be so active.

The direct rays of the sun, he says, are most powerful, but diffused light has the same effect, though not so intense and rapid. The presence of nitrogen is not needed in the decomposition of carbonic acid. The carbon is needed in the formation of the different substances containing carbon; hence it is evident, he says, the quantity and quality of the substances generated by the vital processes must vary according to the food that is supplied, and the development of the individual organs will proceed according as the substances necessary for their development are furnished. The quality will also depend on the quantity, as the action of heat and light in the leaves will separate the oxygen needed to be removed from acid mucilaginous substances, in converting them into sugar and starch, more easily from a small than a large quantity; if the quantity of sap is great, it will require more action to prepare it. In this process heat seems greatly to augment the action of light. When the leaves of celery are shut out from light, the oxygen is preserved even though heat is present; and the bitter poisonous principle in which hydrogen predominates, formerly generated when light was present to the leaves by the deoxidation of the sap, is now converted into sugar. In like manner, if the tubers of potatoes, which are part of the stem, are exposed to the light, they secrete a bitter poisonous principle, similar to that of the stems and leaves, by the deoxidation. Though heat alone will not cause the deoxidation, yet we see it assists it greatly; as, in the instance of fruit trees on walls, we find the separation of the oxygen, and ripening of the acid fruit, proceed with a great deal more vigour than in standard trees, though fully exposed to the light. So

great is the effect, that in some fruits which do not possess much juice, the process proceeds farther, and part is converted into starch, forming a dry mealy fruit, which would have been sweeter on a standard; and fruits abounding in juice are thus the most suitable for walls and warm climates. Fruit will continue to deoxidate after pulling, most in the light, but if heat is present will continue also; and both heat and light should be kept from ripe fruit; a cool dry air and little light will keep them best, unless pulled before ripe. In some fruits, as plums, grapes, &c., part of the skin is wholly deoxidated, and a waxy substance abounding in hydrogen without oxygen is formed, called bloom, which assists in preventing further action. In some, as in *Cactus Opúntia*, a poisonous substance is formed. Heat seems thus greatly to assist the action of light, though light acts as in that of the harvest moons without heat; the states of the moon are said to have great effect on vegetation in tropical countries; they attract the atmosphere, also diminishing pressure, and assisting expansion. The chemical rays in the beam of light should have a powerful effect; and also electricity, which is present often where not suspected.

He next resumes the subject of the blossoming of trees; and attributes the cause of fruitfulness in vines to the pruning of their branches. It is well known, however, to gardeners, that, if the rods of young wood are left long and not pruned, there is much more blossom; in fact, the reason they give for pruning is, that there would be more fruit than the plant could mature if the rods were not cut short, and the more young wood they want they cut the shorter.

The special object of agriculture, he says next, is to obtain an abnormal developement and production of the parts of plants employed as food, or for purposes of industry. When we want to give strength to the straw, the substances giving solidity to the straw, as silicate of potash, must be given; when we wish to increase the quantity of seeds, nitrogen must be given. Wild animals are devoid of fat, as compared with domestic animals. Substances may be given, he says, to increase every vital production; as charcoal powder will produce such an excessive growth of the liver of a goose as will cause its death. The increase or diminution of the vital activity in plants, he says, depends on heat and light, which we have not arbitrarily at our disposal.

The duty of the chemist is to explain the composition of a fertile soil; and on this head he enumerates the quantity of alkalis contained in some of the most common of the minerals; as feldspar, albite, mica, and zeolite, which form part of the most common of our rocks. He gives the statement of the quantity of potash on an acre, if composed of these

to the depth of 20 in., which he estimates at from 300,000 lb. in loam, to 1,152,000 lb. in feldspar; and that a single cubic foot of feldspar would supply potash to an acre of pines for five years; deducing hence the absurdity of supposing that plants would generate potash for themselves, when it is so plentifully formed in nature. Argillaceous earths, he says, yield the most potash, the chalk and sand are necessary to keep them open, and give free access to air and moisture. The soil which is formed by the disintegration of lava cannot possibly contain vegetable matter, and the luxuriance of plants on the lava of Vesuvius, after being a few years exposed to the weather, shows the benefit of the alkalies: these soils are more or less fertile, he says, according to the proportion of clay or sand which they contain. The alkalies, he says, are greatly needed in the germination of seeds and young plants; the acetic acid formed and excreted in the expulsion of oxygen gas, and reduction of the starch to mucilage, is neutralised by the lime, magnesia, and other alkalies, and again absorbed as a neutral salt by the fibres. I formerly pointed out the benefit of alkalies in germination; when there is much starch and little albumen or gluten in the seed, nitrogen should help; putrid urine would do, but the quicklime, if used, would decompose the salts of ammonia, and nitrate of potash (saltpetre) would be best. He quotes the experiments of Struve, to show how water containing carbonic acid decomposes rocks containing alkalies. Plants also, he says, produce acids by their decay and excrement; thus the disintegration of rocks proceeds; and soils, even though exhausted, will, by rest, again produce alkalies. Around Naples, he says, corn has been cultivated for thousands of years, by allowing two years as fallow, or as a sparing pasture to cattle, which can add no alkalies. The harvests of wheat and tobacco have exhausted the soil of Virginia of alkalies; 1,200 lb. of alkalies are taken from an acre every 100 years in these crops, and now the land is unfertile. The exhaustion of alkalies, he concludes, is the sole source of want of fertility in soils. Wheat will not grow in the Brazils, he says, though the soil abounds in humus; nor will it grow in Europe in vegetable soils, because the silicate of potash necessary to strengthen the stalk is wanting, and the phosphate of magnesia for the seeds, neither of which substances a soil of humus can afford; and wheat grows best on clayey soils, because alkalies are contained there in most abundance. Is it accident, he says, that only firs grow in the sandstone and limestone of the Carpathian Mountains; whilst other trees are confined to the gneiss, mica slate, and granite soils of Bavaria, the clinkstone of the Rhone, the basalt of Vogelsberg, and clay slate of the Rhine and Eifeld; the leaves of these trees are renewed annually, whilst the evergreen pine leaves last much longer, and contain fewer

alkalies. This shows, he says, how these trees thrive best after the pine forests are uprooted in America; and how plants, as the *Spártium scopàrium*, &c., grow best where ashes have been burnt. Wheat has more ashes in its straw than barley, and barley more than oats, in the proportions 15, 8, and 4; and therefore three crops of oats, or two of barley, will not exhaust the soil more than one of wheat. The amount removed by hay is also considerable; he instances a stack of hay which was consumed by lightning in the neighbourhood of Heidelberg; and Gmelin found the meteor left in its place was a mass of silicate of potash. The potash may, in many places, he says, be replaced by soda, magnesia, and lime; soda is the most powerful solvent of any, but potash combines most readily in the plant: lime is much more insoluble. Phosphoric acid, another ingredient wanted, is, he says, a constituent of all land capable of cultivation; even the barren heath at Luneburg contains a small quantity; and from the soil, and the grains derived from it, is thus produced the phosphoric acid needed by animals in the formation of their bones: fluoride of calcium seems to have supplied the place of phosphates, in the bones found at Pompeii, and other earlier formations. He quotes from De Saussure, to show that the quantity of potash decreases in wheat as it ripens, which thus restores part of its potash to the soil. The disintegration of rocks restores potash. Beans, peas, tares, and some other crops, he says, contain only a very small quantity of ashes, sometimes none, and should alternate with wheat. The tobacco, containing only as 16 to 97 of phosphates, may also alternate.

From all that has been stated above, we may see the value of the alkalies in all manures; but it would, perhaps, be an exaggerated estimate to lay it down as a principle, that the temporary diminution of fertility is *solely* caused by the exhaustion of alkalies. That they are beneficial I have often seen proof, in noticing that wherever the refuse of nursery plants was burned the potato foliage of the ensuing crop was of a deeper green, and more abundant, and the stems nearly double the height; the tubers were not always proportionably increased. On turnips we have observed the ashes to produce an opposite effect; they sometimes died altogether: perhaps the ashes were in excess. The ashes would also yield carbonic acid; at p. 210. of the Appendix, it is stated that the charcoal in which the plants were grown was ultimately reduced to a coaly earth, having yielded carbonic acid abundantly to the plants. Though it is a substance that does not decompose quickly, it cannot be absorbed in the solid state, as Sir H. Davy's experiments prove; and those of Dr. Lindley, mentioned at the commencement, confirm the above from the Appendix, that charcoal is reduced by plants. If we trust to analysis of minerals for the quantity of

alkalies in soils, we will be apt to be misled. In the latest work on mineralogy, by Mr. Allan, analyses are given, by many chemists, of different varieties of feldspar, in many of which the potash is absent, and its place supplied by lime and magnesia; in the prismatic common sort it is stated as high as 13 per cent. In mica, many varieties under different names are stated as containing no potash, but variable quantities of the other alkalies: in mica, properly so called, and in talc mica, six different analyses give the potash as varying from 5 to nearly 15 per cent, and the magnesia from 9 to 26 per cent. Dr. Liebig's estimate differs from this. The proportion of the different minerals in the different rocks is more various still. Feldspar is generally allowed to be the greatest source of potash, and is found in greatest quantity in the igneous or volcanic rocks, as granite, greenstone, basalt, and other trap rocks. Granite in Bavaria is stated by Dr. Liebig as forming a fertile soil; but in Scotland and England the soils lying on granite are proverbially barren, from their high, bleak, and cold situation, and the thinness of the stratum of soil. Clay soil, the professor says, generally contains most alkali; hard stones of the order gem contain fewer alkalies than those of the order spar, which are softer and more clayey; but some minerals containing a great deal of alumina are almost destitute of potash.

The action of rivers and currents has great effect on soil, according as they carry off or silt over the ground. In the soils in this neighbourhood, which are formed from the debris of sandstone lying above the carboniferous series, and of greenstone or whin disrupted up through it, we have all varieties of soils, from light sandy to stiff clayey. The one side of the river is all inclining to sandy; the other is generally clayey. In wet seasons the best crops are had on the sandy soils, which are generally warmer and drier, and about a month earlier in springing; in warm dry seasons the clayey soils, if pulverised, yield the best crops. Some manures, as cow-dung, retain more water than others; and there is much of the art of cultivation lies in preserving both heat and moisture, which are essential as well as alkalies. The composition of a soil and its proper pulverisation facilitate the entrance of heat and moisture, and retain them to assist with the air in the decomposition of the food; and different soils and seasons require different management. On this subject I treated more largely than I have room for here, in my former essay on Dr. Lindley's work. In our deep alluvial soils, when the alkalies are exhausted by one crop, the disintegration of the rock many feet buried below the surface will go on very slowly: it should take many crops, I think, to exhaust a soil of alkalies. Many crops of wheat are successively, in rotation, taken from ground which gets nothing but ordinary

manure to replace it. Wheat does well to succeed potatoes, and both are found to contain a great deal of alkalies; as do potatoes and turnips, according to Dr. Madden's analysis. The fertility of the lava soils near Vesuvius comes the nearest to the point. Modern lava, however, is more spongy than the old volcanic rocks, from being disrupted in the air, and not subjected to the pressure of the sea above as the old trap rocks were. It is, therefore, more easily reduced to soil; and a few years only will suffice, by the seeds of lichens and their decomposition furnishing food for larger plants; the decomposition and growth of which, in a warm climate, may prepare a soil in which plants, aided by the carbonic acid washed into the soil by rains, and neutralised by the alkalies, may grow crops to great perfection, having both alkalies and organic matter. In the instance of good corn not being produced in Brazil, it has been attributed to the heat of the climate expanding the straw till it becomes feeble, as plants do in our hothouses that are not adapted to them: the silicate of potash, the specific gravity of which, 1.26, is less than carbonate of potash and soda, is as likely to be carried by rain as they are, and should exist in vegetable soils, partly as silicates, seeing potash abounds in these soils. The wheats originally drawn from the soils in Virginia differed in nothing but climate from those of Brazil. The vegetable soils he alludes to as not growing wheat in Europe are probably peat soils, which, from the tannin they contain and stagnant water, are unfit for food till fermented and reduced, when they are said to be as good as manure. In the instance mentioned of pine trees and deciduous plants, if these last shed their leaves annually, they will again return them to the soil, and the alkalies with them. The state of moisture to the roots, and the light, heat, and air afforded to the leaves, are, perhaps, as much the causes of their thriving, as any thing else. The pines thrive in general best on bare dry soils, and are not usually fond of much moisture to the roots. The genus *Abies*, or spruce, however, differs from the other pines in this respect. The larch, a deciduous plant, is said not to thrive on sandstone or limestone rocks unless the soil is deep; Scotch fir thrives well on such, though bare and thin; and both are *Abiétinæ*. The beech will thrive on very bare soil, the ash will not thrive unless near moisture; and both are deciduous. Willows, poplars, and alders, and also ash, will thrive in all moist soils, whether sandy or clayey, if the moisture is not stagnant. Oaks, sycamore, and chestnuts require a dry and deep soil. The oak requires the soil deep; the beech, from its spreading root, will thrive in a dry moor, and so will the Scotch fir. If there is too much or too little moisture for the particular species, or too little light and air, it seems to affect them most readily. The Scotch fir grows well on granitic

soils, if thin and bare, and will also on sandstone; while oak will not thrive so well in bare thin granite soils as when they are deeper. Clovers are found to exhaust the soil in this country more than wheat; at least they cannot be renewed so often on the same ground; and no addition of lime, gypsum, or manure, is found to remove the difficulty altogether. Yet the editor of the *Quarterly Journal of Agriculture* remarks that, if the clover in the rotation is grown for four in place of two years, the difficulty vanishes; what can be the reason of this? If we say it is in affording longer time for the first deposit of excrement to be decomposed, what becomes of the last deposit, and how would it not decompose more readily when the clovers were removed? There are many things in practice that baffle theory; this can only arise from errors in theory, if practice is correctly stated. All are interested in setting things right, that we may have right principles to guide us. I have seen much in what the professor says, to prove the benefit of alkalies, more than could be condensed in an essay; and all are concerned in proving such theories for themselves, before adopting them as principles. If the inferences drawn are correct to their utmost extent, we ought to alter our system much to advantage; if they are to be modified, it can only be done by the aid of practical men in digesting them.

On the next and last division, the *Interchange of Crops and Manure*, he commences by stating the benefits formerly derived from fallows, the land by rest regaining its original fertility; some crops thriving only after a succession of years, as peas, clover, and flax; others, as hemp, tobacco, rye, and oats, being capable of following one another. Wheat, hops, turnips, hemp, poppies, &c., he instances as crops which exhaust the ground. The excrements of man and animals have been employed for increasing the fertility of the soil: they restore certain constituents removed by the former crops. It has been observed, however, that even manure will not always restore fertility, and that alternation of crops is necessary; a change producing fertility as well as fallow. It is evident, therefore, he remarks, that all plants must give back to the soil something that is capable of being used as food by the succeeding generation. Agriculture, he says, has neglected to seek the aid of chemistry, in obtaining a chemical knowledge of the food of plants and of manure; it even recoils with distrust and aversion, he complains, from the means of assistance afforded by chemistry; and some future generation must reap the advantages which the present denies to itself. Practical men should endeavour to do away with the necessity for these complaints; they may be difficult to convince, but, if once convinced, will look to their own interest. He next notices DeCandolle's theory, that plants give out excrements,

and that one plant may live in the matter rejected by another : also the experiments of Macaire Prinsep, which show that leguminous plants grown in water cause the water to acquire a brown colour ; that plants of the same kind will not grow in this water, while plants of corn grow vigorously and clean the water. Some plants he found to return excrements of an acrid resinous nature, which were poisonous ; others a mild gummy excrement, which was nutritious. Excrements differ, he says, from excretions, excrements may contain undigested food ; excretions, the food being already extracted from it, cannot give out food again, till it forms new combinations in the soil by putrefaction and contact with the air. This putrefaction will take place more quickly in a calcareous open soil, than in a more dense and clayey one ; and the rotations may be more quickly followed in the former than in the latter. In some places, he says, clover will not thrive till the sixth, in others not till the twelfth, year. The excrement, he states, must be completely transformed, before a new crop of the same article can be grown. Flax, peas, clover, and even potatoes, are plants the excrements of which require the longest time for their reduction to humus. Other writers have represented the potato as having very little if any excrement. The use of alkalies and burnt lime, or wood ashes not lixiviated, will permit, by their action, the crops to be renewed much sooner. In the soils in the neighbourhood of the Rhine and Nile, which contain much potash, and also organic matter, and in the irrigation of meadows, which brings both substances, the fallowing of the land is superseded by the inundation ; the oxygen of the water also effects the more rapid putrefaction of the excrements.

A fertile soil ought, he says, to afford all the *inorganic* as well as *organic* bodies required for the plants. When the alkalies are in combination with mineral acids, as the silicic, or silex, the ashes yield no carbonic acid ; when they are united to organic acids, the ashes effervesce with mineral acids. The silicic acid is the material from which wood takes its origin, as salts in solution will crystallise round a grain of sand. Silicic acid supplies the place of woody fibre in the *Equisetaceæ* and bamboo, as oxalate of lime does in the lichens. Some plants will not thrive without phosphate of lime or magnesia ; others will not do so without carbonate of lime. Wheat, which consumes great part of the silicate of potash, should be followed by such as require little potash, as beans, peas, turnips, potatoes. At page 104. the ashes of potato plants are stated as 1,500 compared to 83 of firs. The leaves and stems of potatoes should be kept and returned to the soil, and the straw of wheat. The same precautions must be observed in the rotations of other plants, for phosphates, carbonates, &c. To supply



the organic constituents, he recommends fallow plants, as clover, rye, buckwheat, &c., ploughed into the soil when nearly in bloom, to supply humus. Lucerne, he says, is most effectual; it requires few inorganic matters, and, till a certain period of the growth, retains all the carbonic acid and ammonia which may have been conveyed to the plants by rain and air, and the great breadth of foliage prevents the escape of ammonia into the air. When the green principle is produced in leaves, by light and heat stimulating the action of the organs, the remainder of what was absorbed by them is returned as excrements to the soil; and, after the lapse of a few years, he says, every fibre of the roots will be surrounded with them. As these excrements remain for some time soluble, they will act as poison; and the fields will produce barren places till the excrement is decomposed, when they will again become fertile. The roots, as they continue to extend, should partly leave this excrement. We must replace all the other substances, as well as carbon and nitrogen; and it is for this, he says, that *manures* are wanted.

Every constituent of the body of animals is derived from plants; during their life they return the inorganic substances not needed, as excrement. After death their nitrogen and carbon pass into the air in the form of carbonic acid and ammonia. Nothing remains except the phosphates of lime, &c., and other substances in their bones; which must, he says, be a powerful manure for plants, if every thing is to be restored to the land which is taken from it. In the enquiry as to what the excrements yield, he notices that, though animals are fed on substances containing nitrogen, there is very little of it in their excrement, the greater part being assimilated by themselves. In 100 parts of the excrement of a horse, analysed by Macaire and Marcet, only 0.8 of nitrogen was found in 100; and in that of the cow by Boussingault only 0.506. 25 lb. of hay, the food of the cow for a day, should yield  $\frac{1}{4}$  lb. of nitrogen; and this is the quantity found in 8.3 lb. of flesh in its natural condition; and as the daily increase of size in a cow is much less than this, the remainder of the nitrogen must be found in the milk and urine. The nitrogen is therefore found in greatest quantity in the liquid, not the solid, excrements of animals. The quantities of salts and earthy matters contained in horse-dung, he says, is very variable, from 10 to 27 per cent. 1000 lb. of horse-dung, he calculates, will yield inorganic substances to 6000 lb. of hay, the crop on nearly  $2\frac{1}{2}$  acres; or 8,300 lb. of oats on more than 3 acres; and the same quantity would yield phosphates to  $1\frac{1}{2}$  crop of wheat. The excrements of cows, black cattle, and sheep contain phosphate of lime, common salt, and silicate of lime, the weight of which varies from 9 to 28 per cent. The fresh excrement of the cow contains from 80 to 90 per cent of water; that of the horse

from 69 to 75 per cent. Human fæces, analysed by Berzelius, contain 75 per cent of water, from  $1\frac{1}{2}$  to 5 per cent of nitrogen, and 15 per cent of phosphates of lime and magnesia. The vegetable constituents are of influence, as they furnish carbonic acid to the young plants. The quantity, however, is not great, he says, and estimates it only at 5.8 per cent, the greatest benefit being derived from the inorganic constituents. In manuring with cow and sheep dung, we replace silicate of potash and phosphates; with human fæces, phosphates of lime, and magnesia; with those of the horse, phosphate of magnesia and silicate of potash. In the straw litter we add silicate of potash and phosphates; which, if the straw be putrefied, will be in the same condition as when taken up by the original wheat or oats. The soil of a field will therefore alter little, he adds, if we collect and distribute the dung carefully. The phosphates carried off by men and animals will accumulate in the neighbourhood of large towns. This must be compensated for at a distance from towns by letting lie in grass; and near towns by the excrements collected, and by the ashes of the wood used in houses for fuel, which also replace phosphates.

We could keep our fields fertile, by replacing what is taken off; but, when we wish to increase produce, we must add more than we take away. In Flanders this is done, he says, by covering the fields with ashes of wood, either lixiviated or not, and bones which yield phosphates of lime and magnesia. These ashes, he says, are often carried from eighteen to twenty-four miles. The ashes of oaks yield only traces of phosphates; those of beech 20 per cent; those of the pine and fir 9 to 15 per cent, some pines much less. Every 100 lb. of the lixiviated ashes of beech, he calculates, would furnish as much phosphate as 460 lb. of human excrement. 100 lb. of the ashes of the grain of wheat yield 76.5 per cent of phosphates, and the straw 11.5 per cent. Hence, with every 100 lb. of the ashes of the beech, we supply a field with phosphates sufficient for 3,820 lb. of straw, as there are only 4.3 per cent of ashes in the straw; and 15,000 to 18,000 lb. of corn, as the ashes in it amount only to 1.3 per cent. Bones formed by animals from the eating of hay, straw, and corn, yield, according to an analysis of Berzelius, 55 per cent of the phosphate of lime and magnesia; and, calculating that hay contains as much phosphates as wheat straw, 8 lb. of bones will supply phosphates to 1,000 lb. of straw, and 2 lb. to 1,000 lb. of grain. Now, 40 lb. of bone dust, he calculates, are sufficient to supply three crops of wheat, clover, potatoes, and turnips on an acre, with phosphates. The more finely the bones are powdered, and the more intimately they are mixed with the soil, the more easily are they assimilated. The best way to effect the renovation, he says, is to pour over the bones, in a state of fine powder, half their weight of sul-

phuric acid (vitriol), diluted with three or four parts of water; after digesting for some time, add 100 parts of water, and sprinkle the mixture over the field before the plough. The sulphuric acid will dissolve, but not decompose, the phosphates, unless partially; and the free acid unites with the alkalies in the earth, and a neutral salt (probably gypsum) is formed, in a very fine state of division. In the manufactories of glue, he says, many hundred tons of a solution of phosphates in muriatic acid are yearly thrown away as useless; this solution, he thinks, might be substituted for bones. The free acid would form muriate of lime (chloride of calcium), which has a great affinity for water, and might supply the place of gypsum, in forming muriate of ammonia and carbonate of lime. The ashes of brown coal and peat contain also potash and phosphates. It is of much importance, he says, that the mode of action of all these substances should be known; and he illustrates this by the way in which iodine is now used in medicine, instead of burnt sponge, and phosphate of soda in place of cow-dung in calico-printing; and says we may one day manure our fields with a solution of glass (silicate of potash). In this country soda is generally used as the flux for glass. We may also purchase phosphates of magnesia, he says, as we now do medicines from the apothecary. Some plants, he continues, require humus; others can do without humus, and give it off as excrement.

Having now considered what was necessary for supplying plants with the other requisites; he proceeds to consider the production of nitrogen, which abounds in all parts of plants, but especially in the seeds and roots. The atmosphere furnishes it, he says, in quantity sufficient for the existence of plants, to prevent their extinction; but the complete development of the cultivated plants in sugar, starch, and gluten cannot be obtained, unless we afford nitrogen *sufficient*. The nitrogen in the fæces of animals which feed on plants is not so great in quantity as in those which feed on flesh; and the fæces of human beings differ in this respect according to their feeding. The fæces of cattle are of most use in soils which contain little potash; the fæces of men are most useful in clay soils. It is the urine in the manure which contains the ammonia. He takes the analysis of urine by Berzelius, which contains mostly salts of ammonia, water, and urea; the urea in this analysis is 3 per cent; the muriate and phosphate of ammonia about 0.3 per cent; and the free lactic acid, lactate of ammonia, and animal matter, 1.7; mucus 0.032, and other salts about 1.52 per cent. The urea in human urine, according to Henry, is partly lactate of urea, and partly urea in a free state. When it putrefies, the lactate of urea is converted into lactate of ammonia, and the urea which was free into carbonate of ammonia: this last is retained in solution till

spread out on the ground, when, being more volatile than the other salts of ammonia, it is apt to escape into the air, unless washed into the soil, where it may be united to other acids if present, or taken up by the roots, but he thinks it most likely to be volatilised. The other salts of ammonia are taken up by the roots. When the carbonate of ammonia is lost, he says, the loss is equal to nearly one half of the urine employed; and he proposes various methods to fix it: as strewing a field with gypsum, and then with the urine, which will convert the carbonate into the sulphate of ammonia. It may be done more easily, he says, by mixing the urine with gypsum, chloride of calcium, sulphuric acid, muriatic acid (spirit of salt), or superphosphate of lime, all cheap substances, which would convert the volatile carbonate of ammonia into more fixed salts. If a basin of muriatic acid is put in contact with the fumes of ammonia from a necessary, it is converted, he says, into crystals of muriate of ammonia (sal ammoniac). The ammonia which escapes in stables is converted into nitric acid, when in contact with the lime of the mortar, which dissolves the lime, and forms soluble nitrates. If the floors of our stables and necessaries were strewed with gypsum, they would lose their offensive smell, by the volatile carbonate of ammonia, which gives the smell, being converted into sulphate of ammonia, a valuable manure. The uric acid contains, next to urea, most nitrogen; it is soluble in water, and can thus be absorbed by the roots, and its nitrogen formed into oxalate, hydrocyanate, or carbonate, of ammonia. In respect to the quantity of nitrogen, he says that 100 parts of the urine of a healthy man are equal to 1,300 parts of the fresh dung of a horse, and 600 parts of a cow's dung.

The powerful effects of urine as a manure are well known in Flanders; and are considered invaluable by the Chinese, the oldest agricultural people. Their laws attach so much value to human excrements as to forbid their being thrown away, and reservoirs are placed in every house to collect them with the greatest care; very little value is there attached to the excrement of animals. The Chinese were before us in dyeing and painting, and in manufactories of porcelain and silk; but by the aid of chemistry, he says, we have now been enabled to surpass them. How infinitely inferior still is the agriculture of Europe to that of China! They are the most admirable gardeners and trainers of plants in the world; and know how to prepare and apply the best-adapted manures. With us, he says, thick books are written, and we do not know yet what manure is; no experiments being instituted. Calculating the urine of a man at  $1\frac{1}{4}$  lb. daily, and the fæces at  $\frac{1}{4}$  lb., and that both yield 3 per cent of nitrogen, about  $16\frac{1}{2}$  lb. of nitrogen would be furnished annually, which would be sufficient for 800 lb. of

wheat, rye, and oats, or 900 lb. of barley; more than an acre of land would require, when assisted by the atmosphere, for the richest possible crop every year. Every town and farm, he continues, might thus supply itself with the manure containing most nitrogen, and also the most phosphates. By using at the same time bones, and the lixiviated ashes of wood, the excrements of animals might be completely dispensed with.

It is difficult to remove the moisture from human excrements without evaporating their ammonia. In Paris they are evaporated; and this destroys more than half of the nitrogen, though the remainder is still very valuable. The Chinese mix them with marl in dry cakes. He advises to neutralise the ammonia with some cheap mineral acid, such as sulphuric or muriatic. According to the *Library of Useful Knowledge*, the last is best obtained by mixing common salt with an equal weight of strong vitriol. If this mixture were applied, when newly put together, that no escape of muriatic acid might take place, muriate of ammonia and sulphate of soda might be formed; sulphate of lime or sulphate of potash, found both in turnips and potatoes by Dr. Madden, may sometimes be formed also. When quicklime is applied, it seizes on the carbonic acid of the ammonia, forming carbonate of lime, and the ammonia escapes. Mild lime or marl should have partly this effect also. In some marls, containing alumina and potash, it might be retained beneficially. The guano of South America, he says, is mostly urate of ammonia.

The corn fields in China, he says, have no weeds, as they use human excrement, while we sow weeds every year with our manure. I have seen the excrement of cows, when fed on potato plums, quite full of the seed of the potato. It will be the same with most of the small seeds of grasses, &c.: the only preventive is, to rot the manure well, and destroy the seeds.

The urine of the horse contains less nitrogen and phosphates than that of man. It contains only 0·7 of urea, while that of man contains four times as much. The urine of a cow, according to Brande, he says, is rich in salts of potash, and almost destitute of soda. In the analysis by Brande, in *Agricultural Chemistry*, the quantity of urea is stated as 4 per cent, much more than that of a man; reiterated analyses and experiments are perhaps needed before we are certain of being correct. The urine of the swine, Dr. Liebig says, contains a large quantity of the phosphates of magnesia and ammonia. Pasturage is a great means of replacing nitrogen; and, where pasturage is not followed, manures containing nitrogen are more needed. The quantity of nitrogen carried to the grave with every individual, he estimates at 3 lb., and this is again given off to the atmosphere in the state of ammonia. The greatest value, he says, should be attached to liquid excrements; for every *pound* of ammonia, a loss of *sixty pounds*

of corn is sustained; with every pound of urine a pound of wheat might be produced. The phosphates are soluble in urine, and insoluble, till altered, in solid excrements. Bones, wool, hair, hoofs, and horns contain nitrogen and phosphates. 100 parts of dry bones (not boiled) contain 32 to 33 per cent of dry gelatine; and, calculating this at 5.28 per cent, the same quantity as animal glue, 100 parts of bones are therefore equivalent to 250 parts of urine. Bones will keep dry for 1000 years, he says. They become warm when reduced to powder, and the gelatine is then decomposed, but absorbed by the porous bone and retained. Charcoal, in a state of powder, he considers a very powerful manure on heavy soils. He quotes from Ingenhousz to show that sulphuric acid, diluted with 8 or 10 times its weight of water, would be an excellent manure, forming gypsum with the lime in the soil. 100 parts of concentrated sulphuric acid are equivalent, he states, to 176 parts of gypsum; if there is potash in the soil, sulphate of potash may also be formed, or soda, if any.

On this last division of the subject, I would observe that, having frequently used bones as drainage to the bottoms of flower-pots to encourage fine plants, I have observed that the roots refused to enter among the pieces of bones, when small and fermented; and the tips of the spongioles were of a dirty brown diseased colour. I think it is probable this was owing to the carbonate of ammonia, which, the professor says, is absorbed by the bones, being in excess. This is probably the cause why urine, when applied in dry weather, kills so many plants: it is probably too strong, unless when the urine is well diluted with rain or other water. Excess of food is always prejudicial, especially a stimulant food, such as ammonia. When urine is put on in wet weather, it seldom hurts; when put on in dry weather, it should be well diluted. The uric acid being soluble may be the cause of the harm partly, as putrid urine does not hurt so readily. The urine should be carefully kept by itself, and applied fresh to growing plants in wet weather, or in a diluted state; when the carbonate of ammonia already formed will be washed into the soil with the urine by the rain, and any new carbonate produced as the putrefaction proceeds will be given off to the roots as formed, and both carbon and ammonia will thus be given to the plant. Carbonate of ammonia should be the most beneficial to plants of all the salts of ammonia, from the carbon it contains.

The urine of cows is used in great quantities here by gardeners, for manuring vine borders, gooseberry bushes, cauliflowers, &c.; and they wash it into the soil by putting it on in wet weather or using water. It is put on both when the plants are growing, and in a dormant state in the winter: from the volatility of

the carbonate, it should be best to alter it for some mineral acid in the winter. If needed to be kept over, some of the methods before recommended should be adopted to fix the ammonia by mineral acids. Urine of all descriptions should be separated from the solid excrements and kept by itself, and either washed into the soil as speedily as possible, or the salts of ammonia fixed.

The ammonia in the solid excrements, or when they cannot be kept separate, should be preserved by allowing as little evaporation as possible; the air may be admitted without the heat of the sun, and the dung heap should be covered with some substance that would absorb the ammonia and carbonic acid, and not hurt the manure. Quicklime is the very worst that could be applied; the insoluble carbonate of lime is formed and the ammonia set free; most of the salts of lime are insoluble; the gypsum itself requires a great deal of water. Charcoal of wood in small powder, not large pieces, should be the very best; it absorbs the carbonate of ammonia; it will help the decomposition of the charcoal, which is difficult, and the charcoal always contains less or more of potash. A covering of loamy earth a few inches thick, moist, not wet, should retain the most of the volatile substances, and may be put above the charcoal powder, or by itself without any. If the charcoal is in large pieces, it absorbs the ammonia and carbonic acid of the dung, and even the soluble substances, and does not give them off readily. I have seen in my practice one cart of street ashes, which contains mineral coal in the state of charcoal, mixed with four or six carts of cow-dung in the winter; and when it came to be put on in the spring, in place of the rich black manure expected, we had only so much dry straw; nor did the mass when applied to the ground produce much more effect than ashes would have done. The ashes are too often in the state of large cinders, which absorb like a sponge; the remains of domestic fires should be well sifted, and nothing but the powdery dust retained, which will be valuable from the potash generally contained in the state of carbonates and sulphates, and any thing it absorbs will be speedily given out. The night-soil, if kept by itself, is of much more value, incomparably more than the whole heap of cinders, &c., mixed. Much good manure is lost in this way; the night-soil, urine, soapsuds, &c., should be carefully kept separate from the ashes: it is like throwing them to waste, to allow the cinders to absorb them. Unboiled bones are best, as they contain most gelatine; and, if present effect is wanted, they should be ground small and spread thin. Some have fancied, when they found roots clustered round whole bones, that it was for the nourishment they contained; but how will the bone give off nourishment till fermented, which will be very sparingly from

whole bones? The fibres will cluster in the same way round a piece of freestone, limestone, or potsherd. Though the presence of ammonia around all the organs of plants, and in many of their products, leads us to infer its necessity; yet it is, perhaps, too much, to say that every pound of ammonia should produce exactly a corresponding proportional increase in corn. Allowing ammonia to have all the benefits claimed for it, we must have the other constituents likewise, and must take into account the structure of the leaves and other elaborating organs, in which some plants possess much more power than others; also the variable quantities of light and heat, assisting and stimulating those powers. There is some limit also to all these, however far we may be from it yet, in agriculture and horticulture; and if we draw too much on these powers, as in over-fruiting, it may be only to hasten the termination: all the food in the world, though full of nitrogen, will not produce an indefinite increase on the size either of plants or animals; it is, perhaps, necessary to notice this, to prevent our being too sanguine.

Some of your readers, as Mr. Main, will be more able to give information about Chinese operations. In a population so dense, and where labour is so cheap, animals are less needed, and, the ground being better pulverised and weeded, the crops will be greater. The proper pulverisation of the ground, at proper seasons, keeps it open, and admits both heat and moisture more freely, as also the carbonic acid and ammonia of the atmosphere; and, where it is broke into small pieces, the confined air retains heat, moisture, and the gases more perfectly, the small pieces of soil acting by capillary attraction; the heat and moisture on ground well pulverised are, without the aid of instruments, perceptibly more than when it is not so. The great effects of pulverisation and attention to the other requisites of cropping have been frequently pointed out in this and other magazines; in the allotments assigned to cottagers, the produce on which is many times that of ordinary cultivation, and in so populous a country as China, this may have great effect. Many of the improvements in the manufactories of porcelain ware, silk, dyeing, &c., were the results of practical application, discovered by accident, and kept for some time as secrets, though they have been vastly improved on, and many new discoveries made by science.

In what the professor says about the likelihood of uric acid being soluble and absorbed, and the nitrogen it contains converted into ammonia, we may be led to wonder if the small quantity of nitrogen soluble in water (Dr. Thomson says,  $1\frac{1}{2}$  to 4 per cent) may not be taken up by the roots and assimilated. It forms ammonia most readily when newly set free; but the living plant possesses more powers of transformation than we yet can define. At p. 154., it seems probable that the phosphates needed will



be in some measure supplied by the soil itself, phosphoric acid being a constituent of all, even the poorest, soils. To talk of manuring with a solution of glass is startling; if potash is added to the soil, the silicic acid generally abounds, and silicate of potash (glass) is formed in the soil. It requires considerable heat; but the roots likely assist, as in all our grain crops there seems no want of it. Glass is most commonly made in this country from soda. Soda is the most powerful solvent, and will be of most use if the food is absorbed in solution and the bases returned, which, I think, is likely to turn out to be the case. Chloride of sodium (common salt) is very poisonous, if in excess.

It will be seen, in attentively perusing the analysis of manures extracted from Dr. Liebig's work, that they have been made on the presumption that the atmosphere is the source of carbon to plants by the leaves, and that ammonia and salts are the principal requisites to be furnished by manures. It will alter the case materially if we take a different view of the subject, and suppose the principal part of the food to be got by the roots. If we cut down a tree on the stem to near the roots, it will spring away with the greatest vigour; will it do the same if the roots are cut off near the stem, though we keep the atmosphere saturated with moisture, carbonic acid, and ammonia? If the leaves are the only source of carbon, whence the great growth when there are no leaves to feed it, or how does the cutting of the roots prevent the action of the leaves? Can we rest assured that soluble substances will not be assimilated in the plant, when taken up by the roots? when we see that the same substances, as sugar, starch, &c., formed in the plant, in seeds, tubers, and bulbs, around buds, and in all parts of the plant, are taken up in spring, dissolved in the ascending sap, and, assisted by the action of nitrogen (so powerfully described by the professor, and which the soluble substances absorbed by the fibres will obtain so readily from the nitrogen abounding in the roots), assimilated by the plant. If the one are assimilated, so undoubtedly will be the other. If we can add to this the action of alkalies in rendering food soluble, and being separated in the plant, and again returned to dissolve more food; if we take all these into account, we will find many useful constituents in manures besides the earthy salts and ammonia. In green and soft vegetables we will find matter nearly in a state of solubility, which must be put into the soil as soon as possible, or mixed up with other substances more solid, or with earth, to preserve as much as possible of the volatile substances. If the vegetable substances are more fibrous and woody, as clippings of hedges, sawdust, tanner's bark, peat, &c., some substances in a state of fermentation, or which have a tendency to induce that state, should be added. Quicklime is of use in inducing a commencement of decay, by extracting

carbonic acid from the woody fibre, which commences transformation and fermentation; but the carbonic acid that is united to the lime is rendered insoluble and lost: it should not be applied to mixtures where there is much soluble matter, it is of most use in commencing action where it is difficult, as in the woody fibre. Heat and moisture, not wetness, should be encouraged as much as possible in all substances difficult to reduce. Yeast, and all substances containing nitrogen, are above all others valuable for continuing fermentation, which will go on as long as nitrogen is to be found in the compound. Sawdust of beech, ash, and other deciduous trees may be fermented into manure; but sawdust from resinous fir trees is very difficult to reduce: I have kept this and the scales of silver fir cones for years to ferment, and got nothing soluble, unless a few earthy salts: they are as manageable burnt as any other way; the ashes, the most that can be made available, are retained. Tanner's bark, from the antiseptic principle of tannin it contains, is also difficult to reduce, and requires some very active fermenting substance, as yeast. It is the small quantity of oxygen they contain, and the superabundance of hydrogen, which must be separated before carbonic acid is formed, and requires much more heat, that prevent their being made soluble; and, though exposed to the oxygen of the air, the carbonic acid is formed so slowly, that it is dissipated before it can be made available. Alkalies mixed among fermenting substances further the process of putrefaction greatly; acids retard it. Seaweed is exceedingly easily dissolved, and should be well mixed with other substances, or put into the soil as soon as possible. Soft animal matters, the refuse of slaughter-houses, &c., are also very easily rendered soluble; both these and seaweed should be well incorporated with strata of earth, and kept dry and cool.

Much has been said as to the application of dairy and stable manure, whether it should be applied fresh or rotted. Most of our theorists advise its application in a fresh, or unfermented, state; most practical men are in favour of rotting. In the *Quarterly Journal of Agriculture*, we had experiments narrated a few years back, in which an intelligent practical agriculturist measured a certain quantity of manure, which he laid past in a heap to rot; and at turnip-sowing he applied the rotted heap, and the same bulk as the original quantity fresh, to equal measured off portions of ground in the same field; and the result was a very great increase of crop with the rotted manure. Others say their experience has led to a different result. Perhaps the wisest course may lie in a medium. We have seen it incontestably proved, by the experiments of Sir H. Davy and Dr. Liebig, that carbonate of ammonia is given off, less or more, according

to the temperature and rapidity of the fermentation; it is this, and the sulphuretted hydrogen formed by animal substances putrefying, that give the nauseous smells of the dung heap: the last is the most nauseous, and like rotten eggs. Part of the carbonic acid also is lost. Undoubtedly there is loss in allowing fermentation to proceed. The whole quantity, however, stated by Sir H. Davy's experiments was not lost: the water of the dung would contain great part of the carbonic acid and ammonia which was found in his retort. The loss may be greatly prevented by preserving the urine, &c., as much as possible in a separate state, and covering the dung heap with loam. The question seems to lie in, whether the decomposition will go on as well, or to as much advantage, in the soil, as in the dung heap. I am afraid not: the heat and moisture are much greater in the dung heap; and, when fermentation is once commenced, it will proceed much better by keeping in a heap, than spreading out. From the vast quantity of undecomposed organic matter in a fertile soil (I think Dr. Madden estimated it at 10 per cent in some fertile soils), the process of *eremacausis*, or conversion into carbonic acid, must be very slow, when the constituents of the manure are spread in the soil; and putrefaction must render much organic matter soluble in the dung heap, which would not be so for a very long time in the soil, and would not benefit the crops it was intended for.

The dung heap should not be very deep, and ought to be turned frequently, that as much of the surface may be exposed to the oxygen of the air as can be done safely, to carry on the fermentation, and not evaporate too much; the oxygen unites to the free carbon, forming carbonic acid, and is most needed when the substances are least soluble. It should be bedded above loam, on purpose that the dissolved matter of the dung in the water may not be run off and lost. Very heavy rains should be thrown off by coverings, open at the ends to admit air. In very warm weather the sun should be kept off, and the heat in the manure, so necessary to carry on fermentation, should not be allowed to go far: I have seen it, when neglected, evaporate the dung to a white dry straw, nearly in the state of charcoal. Sir H. Davy says, fermentation goes on from  $55^{\circ}$  to  $80^{\circ}$ ; but there will not be much given off till above  $100^{\circ}$ . The heap should be turned to prevent the heat going too far, and cool dry air admitted. In dry warm weather, stable manure will sometimes need watering. A layer of loamy earth should be put above all, to absorb as much as possible of the carbonic acid and ammonia given off. If the putrefaction were maintained in a very violent condition, or continued too long, the whole of the soluble matters would be evaporated into gases, and nothing but the earthy salts remain; and we may err by too much, as well as too little, fermentation. The time cannot be specified; from three to six months should

be sufficient for a mixture of stable and dairy manure; which is the best way to keep it, as the water of the cow-dung corrects the want of it in the horse-dung. Much, however, depends on the warmth of the weather, and the quantity of straw, &c., in the dung. When rotted so as to be easily cut with the spade is perhaps the time when we will have most soluble matter at least loss.

It must be evident that experiments will settle such questions with difficulty, when we consider that, in warm, moist, showery weather, the dung may ferment in the soil as well as in the heap; it may even act as a drain with the undecomposed straw, when the weather is very wet: in dry cold springs, on the contrary, the moisture will soon be evaporated from the small quantities spread in the soil, decomposition cease, and the manure be hurtful; whereas, had it been decomposed, it would have retained its water and soluble food. In general, I should think rotting the manure to a certain extent most beneficial. One of the greatest benefits of manure is, the water absorbed by capillary attraction in its pores; and it will absorb best when rotted. Sir H. Davy was of opinion, that the powers of a fertile soil may be tested by its powers of absorbing water. All organic substances possess this in a great degree. Calcareous substances absorb water, and keep the soil free, which is one of the greatest benefits of lime; sand, generally of quartz, keeps the soil open, but retains no moisture; alumina or clay absorbs water, but is apt to agglutinise into solid impervious skin and lumps, preventing the access of heat and air to the soil, and keeping water stagnant. A due proportion of quartz, or silex, and lime, is therefore necessary in all soils to keep them open; some white sandstones, as that contained in heath mould, have so much alumina and calcareous matter in their composition, that they both keep open and retain moisture: it is of great use in peat soil, which, if once thoroughly dried, is not easily moistened again. The moisture absorbed by well decomposed manure is of great value to the roots in dry weather; it is a solvent for the food, and is needed as a constituent of the food itself, affording hydrogen and oxygen in the proportions found in most vegetable substances. Cow-dung containing most water is best for dry sandy soils, and horse-dung for cold clayey soils; but they decompose best together, and there is not so much difference in the water contained when both are rotted: fresh straw manure drains off the water. According to Dr. Madden's analysis, the water in dairy manure is nearly three times that in stable manure; the organic matter in both is nearly the same, almost 40 per cent; as however, in the dairy manure, only one half was soluble in water and potash, while in the stable manure it was two thirds, we see the benefit of mixing the two together, that both may

decompose alike. A little further fermentation in the manure might have made more of it soluble, without a corresponding loss; and in such analysis chemistry might greatly aid practical men. The dung of high-fed animals is always allowed to produce most benefit; there will be most undigested matter in the excrement, and from feeding on grains most nitrogen. Dr. Liebig says, fat animals have most free nitrogen.

Oils are valuable as manures; they will keep long, as they are not easily decomposed, and are rendered soluble by being mixed with potash and soda, in which state they are taken up as soluble soaps, and their carbon, &c., assimilated in the plant. The uncommon fertility of bleaching-greens, when newly broken up, is a proof of this. I have seen soils not otherwise rich produce immense heads of cauliflower at first breaking up, which could not be made to do so afterwards; cauliflower is well known to require both rich soil and extra manure, yet did the soap-suds in a bleaching-green suffice to impart that quality to a poor black sandy soil. The lixiviated ashes of soapers' waste are likely to contain both oil and alkali, and the contents of the washing-tub should never be thrown away; they are soluble, and not easily evaporated, and may be spread on the land, or thrown on the dung heap; when thrown in the ashpit they are absorbed by the cinders and lost. It would be advantageous to mix oily substances with soda or potash, before committing to the soil; if there is much lime in the soil, it is apt to form an insoluble soap between the oil and lime, while the other with the soda and potash is soluble. We see hence the benefits of the scourings from woollen manufactories; they consist in the oil and alkalies of the soap and wool, and the urine used in such processes; it has been used in this quarter with great effect. Hair, wool, and skin, from tanyards and curriers' works, contain gelatine, albumen, and other principles, similar to those in bones, which have already been treated of; the oil used by the latter will be beneficial, the tannin and lime of the former detrimental. Bones are best unboiled, boiling removes much of the gelatine and nitrogen. Horn contains more animal matter than bones, and is similar; the parings of horses' hoofs are apt to contain filings of iron, which are prejudicial, as they oxidate. Blood contains most of the animal constituents, and must be valuable; the colouring matter is supposed to be mostly different from iron. The uses of the waste of glue manufactories we have already quoted from Dr. Liebig. Of the refuse of other manufactories the operation may be known, when we get a knowledge of their contents. Rape cake contains vegetable matter, holding nitrogen in a state of decay, and oil; if potash, or ashes of small branches and leaves of plants, were mixed, they would render the oil soluble, and retain any carbonic acid or

ammonia given off. Linseed cake is similar. Malt dust, the refuse of the sprung radicles, contains vegetable matter, mostly sugar, a highly concentrated food, and may be diluted. Peat may increase the quantity of manure largely, if fermented with hot fermenting stable dung. Quicklime will commence decomposition in it, but will not carry it on so well, and absorbs the carbonic acid. Refuse of herrings and other fish contains soft animal substances and small bones, and decay proceeds very fast; it also contains a good deal of oil, and potash or wood ashes in powder should be added to make the oil soluble. The small branches and leaves contain most alkali, and are fittest for ashes, which should be burnt and reduced to powder. As the soft animal matters are easily soluble, they should be mixed with earth to absorb. The virtues of night soil, human fæces, and its powerful fertilising effects, have been already pointed out; also of urine. According to Berzelius, there is more than 10 per cent of vegetable, animal, and extractive matter in human fæces, besides salt 1·2 per cent, and insoluble matter 14·7: water 73·3. There is much loss in those manures, by being mixed with large spongy absorbing cinders from domestic fires; these should be sifted to fine powder, or kept by themselves: there is much more loss in this way than is generally known. As there is generally sulphur in mineral coal, the powder is likely to contain carbonates and sulphates of potash, and perhaps lime. The dung of swine is allowed to be as good as dairy or stable manure, if not better, when bedded with straw; but there is great loss in this manure from being mixed with coal ashes, and the swine bedded with sawdust from fir-wood. This will keep for years without becoming soluble; the want of oxygen in the resin, to carry on putrefaction, is the cause. It would be a great profit to pay the people for the sawdust, to keep the manure by itself; it does much harm by absorption, in place of good. The dung of domestic fowls, and that of rabbits, sheep, &c., are all allowed to be very strong. I do not recollect any particular analysis of these: they ferment readily, and should be mixed with other substances if kept long.

Mild lime is valuable in soils, as retaining water, keeping open, and increasing heat; quicklime, as tending to commence decay in undecomposed substances. In some soils with a superabundance of carbonic and other acids it will be useful to neutralise these, but it may do harm where there is little organic matter; mild lime would be best there. Lime is said to be most valuable when united to humic acid. The value of this might be tested by mixing moss water with quicklime. There is humic acid in all moss water; and, though in small quantity,  $\frac{1}{2500}$  part, humate of lime would be formed. From Sir H. Davy's experiments in mixing quicklime and tanners'

bark, it would appear that humate of lime was then formed. Dr. Madden (*Quarterly Journal of Agriculture*, No. xlv., p. 90. and 91.) makes its components 28 of lime to  $318\frac{1}{2}$  of humic acid; and humic acid contains 58 per cent of carbon: he thinks humate of lime is gradually formed in the soil. Dr. Liebig is of a contrary opinion. It will depend partly on whether the humic acid has more affinity for lime than the carbonic acid. Carbonate of lime is reckoned insoluble in water; humate of lime, Dr. Liebig says, is no more soluble than the acid. It would appear, also, he thinks, that humate of potash and soda is not more soluble, which differs from most other combinations of potash and soda; they generally form more soluble substances with the acids than before neutralisation: it would appear that Dr. Madden thinks them more soluble. Some future analysis may give more certainty on these points, and experiments might be made on quicklime and moss water. As the acid is only  $\frac{1}{2500}$  part of the water, and 1 part only of lime combines with between 11 and 12 parts of the acid, much lime will not be needed in the process; and, after being some time mixed, the water may be evaporated: any humate of lime formed will be of a brown colour. Lime, in its caustic or quick state, is soluble in water, and, Sir H. Davy says, poisonous. Being a substance not generally assimilated in the plant, it will be poisonous if in excess; so are soapsuds, though a manure; and so were sugar and starch, when Sir H. Davy applied them in a *concentrated* state. But great quantities of lime-water are applied regularly by gardeners to kill vermin; it is reckoned the least hurtful to plants of all the substances employed to kill insects: I have used it in great quantity, and never saw it kill a plant yet. Sir H. Davy says, limestone containing magnesia is hurtful, because the magnesia after burning does not regain its carbonic acid so quickly as the lime, and remains longer in a caustic soluble state; the lime regaining its carbonic acid quickly is the reason, he says, why the caustic soluble lime does not so often do harm, as it is neutralised before reaching the fibres when put on in small quantities of lime-water, or when washed slowly into the soil by rain. Magnesian limestone, he says, is generally brown or pale yellow. When vitriol is poured on lime, sulphate of lime, or gypsum, is formed, which, as before stated, is valuable as a manure. Vitriolic matter is found in peat soils. Some minerals contain a good deal of sulphur. Gypsum and sulphate of potash are formed where sulphuric acid and these bases are found; and clover, being fond of sulphate of lime, is found to spring, as it were, naturally in such soils. Clover is said to assimilate sulphate of lime as a constituent. Soda in the state of sea salt is soluble, but acts as a poison when taken in any quantity. Sir H. Davy thinks it may

be deprived of its chlorine by degrees, if mixed with water containing oxygen; and it may thus, gradually, come to be beneficial in a soil: to some plants it is useful as forming a constituent. Dr. Madden says it sometimes, in a moist state, acts on the lime in the soil, forming muriate of lime and carbonate of soda; but is apt to resume its original form again. Nitrate of soda is formed largely, by natural processes, on the surface of the soil in Peru, &c.; and nitrate of potash (saltpetre) in the same way in India; and both are now much used as manures. Heat is necessary in forming nitric acid, and a basis of lime; it is, therefore, most readily formed in warm climates, and unites to the bases of potash and soda according as they are found in the soil. Nitrate of lime is also generally found mixed with these salts. They form an article of commerce from warm countries, and are manufactured in France and other places in beds in the open air. In some trials recently made by Archibald Hamilton, Esq., of Carcluie, (to whom this county, and agriculture in general, are so much indebted for setting an example in improvements,) on his estates at Roselle, near Ayr, both substances appear to have succeeded well. On fields in which these salts were sprinkled, at the rate of  $1\frac{1}{2}$  cwt. per acre, while parts of the same fields were sprinkled with common salt, and part left without any application of salts, the increase of produce where the nitrates were sown was astonishing on the grass of pasture, and the straw and grain of wheat and oats; turnips, potatoes, and most other farm produce, were also benefited: the common salt produced no effect. The benefits must have arisen from the nitrogen supplied to form ammonia, and the solvent power of the bases, if returned. In parts of the fields where the oxides of iron abounded (as stated at the time in the *Ayr Advertiser*) no benefit was derived. From the great affinity of the protoxide of iron for salts, nitrate of iron would be formed, by the iron separating the nitric acid from the potash and soda. Dr. Thomson says, when the protoxide gets more oxygen from the air, it forms peroxide, and the acid is set free: the nitric acid would thus likely be lost in the air, and the good effects of its nitrogen never felt. From the great affinity between iron and the acids, it is very hurtful, and, if sulphate of iron is formed, poisonous. Carbonate of lime (chalk, or mild lime) converts the iron into carbonate of iron, and the sulphate of iron into sulphate of lime. The salts of iron are so susceptible of change, that their bad effects may not be always felt in the same way. Oxides of iron exist in all soils, and are not detrimental till their quantity, giving the subsoil a red and glistening appearance, shows they are in excess. Being the most general colouring matter, they are very prejudicial to the colours of fine tulips and other flowers, when in excess. Most ditches, if



they run far through clayey or mossy soil, contain a great deal, as may be seen from the colour of the water; and the scourgings of such ditches are very improper in composts for fine flowers. Coal tar, Sir Humphry Davy says, contains a good deal of carbonate and acetate of ammonia, and should be useful. Soot, he says, likewise contains a good deal of carbonate of ammonia, also an empyreumatic oil. The carbon of the coal is also in a state of flocculent powder, fitted for absorption and decomposition; and the good effects of strewing it on soil in wet weather, when it may be washed into the ground and yield both carbon and ammonia, are well known. The quantity of carbonate of ammonia in any of these substances may be guessed at by the pungency of the smell given off, when diluted in water, and mixed with quicklime.

I have now gone through the most of the substances used as manures, and given the different views that may be taken of their action, as far as in my power. It should be recollected, also, that all bulk is not produce in the sense of food, much of it is water; but it is not always even weight, and excitement may expand the tissue without a corresponding deposit of food being made in the tissue. From the extensive views of the professor on the subject of nitrogen, it would seem of immense use, both in stimulating and assisting the actions of vitality and chemical force; and is also, when assimilated, a great cause of the nutritive condition of the food that plants yield to animals.

The whole of Part I., the practical part of the work before us, has now been considered. I have given, as well as in my power in a single essay, a condensed view of the professor's opinions; every page, however, contains a mass of information and reasoning which cannot be comprised in so small a compass; and I would earnestly advise all practical men, and all interested in cultivation, to have recourse to the book itself and think for themselves. The subject is vastly important, and we cannot estimate how much may be added to the produce of our fields by proceeding on correct principles. Though the information to be got from the work is immense, yet I think practice would have enabled the professor to modify many of the inferences deduced therefrom; and, while giving a condensed view of his opinions, I have throughout interspersed remarks of my own. I have brought practice to bear on theory as well as I could; and wherever my practical brethren differ from me, I hope they will come freely forward; it is the collision of opinions only that can enable us to arrive at the truth. We should divest ourselves of prejudice, and sift our own opinions as well as those of others, or we will be apt to endeavour to make facts bend to preconceived theories, to the prejudice of truth. We should not give up the point till convinced, but we should not raise obstacles

to conviction. We should differ from one another whenever in our power, not from the love of contention, but to endeavour to establish truth.

The second Part is a masterpiece of condensed reasoning on chemical transformations, showing the difficulties attending on attempts to arrive at a correct analysis of organic substances, from their compound complicated nature; the necessity of nitrogen in the nature of the yeast formed in all fermentation, also the difference between fermentation and putrefaction; the difference between *eremacausis* requiring a constant supply of oxygen, and putrefaction which does not; the nature of the vinous fermentation, showing the best means of preserving the greatest quantity of alcohol, the strength of beer and wine, by the degree of temperature, &c., maintained; the nature of the decay of woody fibre and mouldering bodies, pointing out the results that take place; the nature of poisons, contagion, and miasms, and their mode of action. The subject is itself condensed, and a proper idea of it can only be got from the work: it is interesting and important to many descriptions of persons besides the cultivators of the soil.

*Kilmarnock, Jan. 23. 1841.*

---

ART. II. *Additional Notes on the Progress of Gardening in the United States.* By A. J. DOWNING, Esq.

IN my notes to you on the progress of gardening in the United States (Vol. for 1840, p. 642.), I accidentally omitted any allusion to the taste for cemeteries or rural burial-grounds which has lately sprung up among us. Some of these are exceedingly beautiful, displaying much of the beauty of landscape-gardening in the natural style. Mount Auburn, near Boston, is one of the finest examples, and has been pronounced by good judges superior in many respects to the celebrated *Père la Chaise*. The area embraced is about seventy acres, and its characteristic beauty consists in the very great natural variety of the surface, clothed with a profusion of fine trees of indigenous growth. Open smooth glades are followed by shady and secluded dingles, and these by wild and picturesque hills, all so rapidly presenting themselves in succession, and so ingeniously displayed by winding and irregular carriage roads and footpaths, that the whole appears two or three times as large as it really is. There are a great number of elegant monuments in marble and granite, in the form of columns, obelisks, sarcophagi, &c., some of them highly elegant, and a few imported from Italy at very large cost. Portions of the place exhibit all the floral beauty of highly kept pleasure-grounds, while other parts have all the wildness of rude nature. It is a favourite resort of the citizens of Boston, and

one can hardly conceive a more lovely place of repose for the dead.

In the neighbourhood of New York, the Greenwood Cemetery lately laid out for the purpose bids fair to eclipse Mount Auburn. In size it is much larger, and if possible exceeds it in the diversity of surface, and especially in the grandeur of the views. Every advantage has been taken of the undulation of surface, and the fine groups, masses, and thickets of trees, in arranging the walks; and there can be no doubt, when this cemetery is completed, it will be one of the most unique in the world.

Laurel Hill, about two miles from the city, is the boast of the Philadelphians. Instead of having been formed upon a picturesque natural surface, covered with natural forest trees, this cemetery was formerly an elegant country residence, bordering on the Schuylkill river, and displaying a kind of gardenesque beauty in the trees, shrubs, &c. Since the grounds have been applied to the purpose of burial, a pretty entrance gate and cottage for the superintendant, and also a neat Gothic chapel, have been built. There are innumerable monuments tastefully disposed in various parts of the place, and many of the small enclosures surrounding these are filled with the most beautiful flowering shrubs and plants. The variety of China and Noisette roses in particular is very great; and these, as well as many rare exotics, are trained and kept with the greatest care.

Beside these three principal cemeteries, there are at least a dozen others in progress in the neighbourhood of other cities. It is remarkable that these cemeteries are the first really elegant public gardens or promenades formed in this country. In point of design, keeping, and in so far as respects the variety of rare flowering shrubs and plants introduced, they are much superior to the majority of country residences here, and may therefore be considered as likely to affect in a very considerable degree the general taste for laying out and embellishing grounds. Hundreds of the citizens who ramble through them form perhaps their first acquaintance with many species of plants there, and apply the taste thus acquired to the improvement of their own gardens.

*Botanic Garden and Nurseries, Newburgh,  
near New York, Nov. 29. 1840.*

---

ART. III. *On the comparative Temperature of different Years, and its Influence on Vegetation.* By N. M. T.

WE generally talk of hot years and cold years, as if in these respects years materially differed from each other: but this is not the case, as it appears from actual observation that the

average temperature of London is  $50.4^{\circ}$ , and that the hottest or coldest seasons we experience do not materially affect this average, seldom causing it to vary even half a degree. And when we consider that it is nearly impossible to ascertain correctly the actual amount of temperature during a season, we may almost conclude that in this respect years are invariably alike, and that the (to us) incomprehensible machinery of the weather is regulated with incontrovertible precision, the very air we breathe "weighed as in a balance." However, for every practical purpose, it will be sufficiently accurate to assume that, so far as regards temperature, years are invariably alike, and that in a given time we may depend upon receiving a stated quantity. Now the heat of every season being alike, and the effects produced so different, the difference must proceed from the manner of its application: and it is by narrowly observing that manner, that we may glean useful information enabling us to ameliorate the condition of even external objects; but, these being placed in circumstances in a great measure beyond our control, our operations must of necessity be limited. Therefore it is to the manager of artificial climates, who has all the requisites (light excepted) under his immediate control, that the information gained from such observations must prove most extensively useful.

It requires no hesitation to say that hot summers are most desirable. For the production of these, the preceding winters must have been sufficiently severe to create a deficiency that demands a proportionate excess to supply; consequently weather in extremes is most congenial to the vegetable productions of the earth, a fact that has not escaped even the unlettered cultivator of the soil, who may often be heard deploring the loss of hard (or as he terms them "old-fashioned") winters. Mild winters, by an excess of temperature, preclude the possibility of hot summers, and prove hurtful to vegetation, by rendering winter and summer too much alike, depriving the plants of absolute rest, by causing them to spend the time that ought to be devoted to such a purpose in a semi-torpid state, the after languid excitement consequent upon such a state of things being insufficient perfectly to rouse them from their lethargic condition. A state of absolute rest is a provision of nature that seems indispensable to the well-being of many of the vegetable productions of a rigorous climate, where existence in a state of excitement during times of severity is incompatible with their organisation; and, whatever the necessity for its return at a stated period, the term of its duration is indefinite, varying considerably even when left to nature, and can be shortened or altered almost at pleasure by the hand of art, as it requires only a proper degree of heat to call their suspended powers into action at any time that

may be wished. When the natural period of rest is shortened by artificial means, for the first time the call will not be so speedily responded to as when the same means are uniformly persisted in: but such is the adaptiveness of plants to the circumstances in which they may be placed, such even in inanimate nature the almost irresistible force of habit, that forced plants become so inured to premature excitement, that they will at the usual period make an effort at growth independent of circumstances; a fact obvious to the most superficial observer, and which renders the alternate resting and forcing, recommended by some, one of the most unphysiological propositions ever suggested to practice.

The growing season of plants is thus changed at pleasure in artificial climates by the application of a spring-like heat, and much stress has justly been laid upon the manner in which it ought to be applied, most considering extreme caution necessary, advising to commence and proceed by almost imperceptible gradations. In early forcing, when light is a desideratum, this appears necessary, but as the season advances this becomes questionable: if we may judge from the proceedings of Nature, she often commences her most favourable seasons in a more abrupt manner. A fine, genial, uninterrupted, consequently rapid spring, is most favourable to the healthful development of the organs of plants; a cold, ungenial, consequently protracted one, one of the most unfavourable things that can happen: and the noble trophies of Continental vegetation, where the transition from iron-bound winter to luxurious spring seems but the magic transformation of a day, exhibit none of the debility we attribute to the effect of rapid excitement; considerations that render questionable the very protracted spring applied to force plants generally, and invite to further investigation. All this would lead to the conclusion, that all plants capable of being so treated ought to be allowed a season of rest, and that a somewhat gradual application of excitement to be uniformly increased is necessary until they complete the object of their growth; and it is also evident that they ought to be enabled to do so, in the most unhesitating and vigorous manner. Nevertheless, gentle forcing is a favourite term and frequent practice with many, but surely it must be erroneous. To imitate successfully a propitious season is the object of all forcing: therefore the question simply is, whether by gentle forcing we will imitate an unfavourable one, with all its sluggish concomitants, laxity of organisation and imperfect maturation; or, by more decided measures, imitate one of the most favourable character.

Thus far, with regard to the application of heat in artificial climates, while following the track pointed out by nature, we have gone hand in hand with reason, and gardeners have

been complimented upon attempting to reconcile their practice to such a standard; but, in doing this, in many cases we must abandon nature, as they are often irreconcilable, nature being often most unreasonable, or reason most unnatural. As an example in point, let us observe her mode of applying moisture, which is often truly disproportionate to the heat: there are sometimes months together intensely hot, without a single drop, and that at a time when vegetables, according to our ideas, reasonably demand a most liberal supply, and to withhold it to the same extent in artificial cases would prove inevitable destruction. Again, in the dreary dripping months of winter, nature dreadfully outrages all the sage maxims of reason: plants then, particularly deciduous ones in a dormant state, are reasonably kept dry, while nature unsparingly drenches the leafless plain, causing the inert and torpid objects of her bounteous care to stand under such circumstances in an actual puddle, and their after-success is often proportionate to the excess they may then endure, which renders it probable that our caution is in part unnecessary, perhaps injurious, and demands investigation.

Although cold winters produce a corresponding increase of heat in summer, it does not altogether follow that such summers will prove so favourable to external vegetation as we could wish, the undeniably beneficial effects of warmth being often rendered abortive by untoward circumstances. Sudden changes from heat to cold are the most frequent and most injurious of these, often in a few hours counteracting the genial influence of months, and crushing beyond all hope of remedy the well-grounded prospects of the hapless cultivator; the heat is also occasionally unseasonable or misplaced, of which last year affords a memorable example. So far as regards the mass of things, all this is in great measure uncontrollable: but the cultivator in an artificial climate is altogether independent of such casualties, they cannot possibly affect him, but by accident or neglect; but, however secure he may feel, such occurrences afford a useful lesson, as, by marking their baneful effects upon external objects, he will be prompted to increased vigilance, lest by any means similar vicissitudes should occur in any department beneath his care, and he will do well to bear in mind the far more susceptible nature of the objects fostered there.

Exotics of annual growth, bulbs, or any other sorts that are taken up, preserved during winter, and returned to the earth at a proper season, will do best in seasons most favourable to such as are indigenous; but it is not a little curious to observe, that, to such as are turned out permanently, seasons most favourable to natives must prove most destructive, and unfavourable seasons must be so far favourable to them, that they will be able at least to prolong their existence: and this must ever prove the case,

unless some means of covering is devised, to enable them to bear the severity necessary to produce a favourable season; they will then, in common with all others, partake of its benefits. Acclimating plants is now set down as a chimera. This decision is unwarranted and impolitic, impeding the progress of farther enquiry, by deterring those who may be inclined to dispute its accuracy from making any further attempt. That we cannot do much, is no reason why we should not do what little is in our power. But, in the face of such a declaration, many plants now turned out and doing well would not, fresh imported, exist a month. Many that have been frequently lost to the country, or preserved with the greatest difficulty in a stunted existence, have, now that they are become reconciled to the climate, assumed the luxuriance of weeds. Their natures may remain unchanged, I admit, not so their habits: these are so far changed, that they are brought to respect our seasons, a point of the greatest importance gained, which is indispensable; a native placed in circumstances which cause it to neglect this, is equally susceptible of injury. If plants, in their natures, are immutable, no treatment can render them more tender, and cultivation has, I think, in some instances done this.

*Folkstone, Jan. 16. 1841.*

---

ART. IV. *On Mr. Corbett's Mode of Heating by the Circulation of Hot Water in open Gutters.* By J. R.

I HAVE never seen Mr. Corbett's plan of heating in operation; but from the description of it, by himself and others, it appears to be, for many purposes, a very good one, and falls in with my notions about providing plenty of moisture in our artificial climates. For Orchideæ, melons, and cucumbers, I should think it excellent; for stove plants, at certain seasons, equally so; but, for other garden purposes, its utility must depend upon the power of completely covering the troughs, and regulating the escape of moisture.

The idea of applying it to dwellings is so perfectly absurd, that such a suggestion in Mr. Corbett's prospectus led me to think his whole scheme chimerical, and even to doubt whether he had ever tried it in any form. For greenhouses, as well as for forcing grapes and pines, it would require two or three years' experience to satisfy me of its advantages; especially for the two latter purposes. Heat is often employed in gardens more to dry than to warm buildings; as, in greenhouses and late vineries, during damp weather in autumn. It is also necessary to obtain dry heat to ripen the wood of all forced plants; and, though I have no experience of pines, I do not imagine they

will ripen to be good for anything, except at a high temperature and pretty dry atmosphere. In all these cases, then, it is absolutely necessary to prevent the escape of moisture from the troughs. If this can be done, the only remaining objection is the difficulty and inconvenience of obtaining a perfect level for the troughs.

Without wishing to rob Mr. Corbett of the credit due to his ingenuity, I must observe that the system he adopts is not altogether so new as he supposes; but is, in fact, a return, in some degree, to the form of the earliest hot-water apparatus erected in this country. All of these consisted partly of pipes, and partly of open cisterns, on the same level, having covers to regulate the escape of moisture. Such an apparatus is described and figured in vol. vii. of the *Hort. Trans.*, p. 203., by Mr. Whale, gardener to Anthony Bacon, Esq., in whose garden the apparatus was erected; and I have seen many similar apparatus of the same date. Mr. Corbett's plan converts a larger portion, or the whole, of the circuit into open cisterns, or troughs; which, for many kinds of plants, and for forcing at certain seasons, is very desirable; but its efficiency must depend upon the power of withholding moisture at will, as even *Orchidææ* require a season of rest and drought.

*Surrey, January, 1841.*

P.S. — Why the old plan of open cisterns has been abandoned, and close pipes preferred, I know not; but suspect that the greater facility of laying the pipes in different situations, and at different levels, has led to the change.

---

ART. V. *On increasing Plants by Cuttings, &c., by the Use of Charcoal.* By Professor ZUCCARINI of Munich. (Translated from the "Garten Zeitung," by J. L.)

I TAKE this opportunity of laying before the friends of gardening a number of experiments, which, though they have been very recently made, justify in their results our warmest expectations. They refer to a method, new in this neighbourhood at least, of increasing plants by shoots, leaves and parts of leaves, calyces, &c., by inserting them in charcoal dust; and this practice has been followed by the best consequences, even with those plants that seldom or never make roots in the usual way of treatment.

Last spring an industrious and clever assistant in the Royal Botanic Garden here, M. Lucas of Erfurt, discovered that several plants in the hothouse that were plunged in charcoal ashes, or the refuse of charcoal, showed an extraordinary vigour of growth as soon as they had pushed their roots through the



holes in the bottom of the pots into this under stratum. Among other plants, this was strikingly the case with peireskias, casuarinas, and *Thunbérghia alata*; all of which, without any artificial fecundation, ripened a quantity of seed, &c. M. Lucas very properly thought it necessary to follow up this chance discovery in a number of experiments, by adding a proportion of charcoal powder to the usual mixed soil in which plants were already rooted, and also by using it pure for cuttings instead of sand.

About the middle of July he communicated to me the result of his experiments, and I thought the importance of the case required that I should urge him to make greater and more varied observations. Accordingly, plants from many different families were chosen, cuttings made from twigs, leaves, parts of leaves, &c., and a day-book kept of the results. The time is too short to allow of a perfect account of all that took place to be given; and circumstances did not allow of all due attention being paid to the experiments at that busy time of the year. Yet I think that the results already attained give sufficient proof of the advantages of this method. When cut leaves of the mimosas and zamias, encephalartos, and agave, and leaf-bundles of *Pinus excélsa*, &c., form a callus in a short time, from which they put forth strong roots; when cuttings of other plants root and grow in a much shorter time, and more certainly, than by any other method; I think it high time to lay the case open to the approval of competent judges. I shall refrain from saying anything of the cause of charcoal's stimulating the growth.

With respect to increasing plants by leaves and parts of leaves, I must mention that those leaves are most suitable for the purpose that have strong prominent veins. In parts of leaves, for example, the callosities are always formed at the cut ends of the veins, so that, according to the position and direction of the latter, a leaf will form a callosity at the same time from the central vein, and from the second, fourth, &c., side veins. These callosities often attain the size of a large pea before putting out roots, and form a bud which continues to grow as a separate plant. It is of advantage in many cases, as soon as the growth of the callosity is sufficiently advanced, to remove the cutting from the charcoal into a proper sort of mould; and, by this means, the little knob being able to provide its own nourishment will prevent the untimely exhaustion of the parent leaf. If this precaution is delayed, an entire stoppage takes place in the growth; the knob produces neither roots nor buds, and dies; because the parent leaf cannot yield any more nourishment, and the charcoal appears to have a preserving and stimulating rather than a nourishing quality.

I leave it now to M. Lucas himself to give the experiments hitherto made.

*Result of the Experiments made by the Application of Charcoal for the Propagation of Plants by Cuttings, &c.* By M. G. Lucas, Royal Botanic Gardens, Munich.

IN laying my experiments on this subject before the public, I only regret, that, owing to the shortness of the time, they are not more full and perfect. It is my earnest endeavour to pursue this subject further, and to lay my yet uncertain and future observations before the lovers of plants. The experiments hitherto made are divided into those made with cuttings, and those with parts of leaves, and other parts of plants. I have arranged them according to the length of time the different plants took to show their capability of rooting. As many experiments took place in autumn, and the specimens could not always be selected to correspond in size, there is no great certainty to be attached to it, but I know of no better way of enumerating them. At the end I thought it necessary to give a list of those sorts of plants which have not succeeded in being propagated in charcoal. I have only to beg further, that my communication may be looked upon, by all lovers and friends of gardening, only as a zealous endeavour to do my utmost in my calling, and may be received accordingly.

A division of the hothouses of the botanical garden here contains a bed which is warmed by means of a tube of sheet iron, instead of tan. This bed is filled with charcoal cinders about three quarters of a foot high, and is chiefly used for keeping young and tender plants. These cinders are for no other purpose but to prevent the mould on plants, a disease which so frequently occurs in tan-beds; and they answer the purpose perfectly well, for, besides preventing mould, they harbour neither worms nor woodlice. At the front and warmest part of this bed, where the pipe enters, are suspended several boxes with glazed sashes as covers. In these boxes plants are propagated throughout the year, partly in pots and partly in mould. In one of these boxes I made experiments in rooting cuttings in charcoal cinders. I must also mention that this bed had a slight fire-heat throughout the summer; it was so slight, however, that it had no effect but on the front part devoted to the cuttings. The charcoal used in these experiments is fir charcoal, the refuse of which, being too fine to be burnt, may be had in quantities from smithies and gentlemen's houses without payment. It is sifted through a coarse earth sieve, to separate the large pieces that are often found in it, and which would only be troublesome, and it is then used without further preparation; it ought to be observed, however, that these ashes are more suitable, and answer the purpose better, when they have been for some months exposed to the influence of the air and weather. In the propagating box it is laid 4 in. thick over the bottom, as a deeper layer would pre-

vent the access of heat, charcoal, as it is well known, being a very bad conductor of heat.

1. Cuttings of the following species of plants planted in charcoal rooted:—

In from 8 to 14 days, *Euphòrbia fùlgens*, *E. fastuòsa*, *E. picta*, *Héchtia stenopétala Klotzsch*, *Ipomœa pùrga*, *I. œnothèroides*, *I. supérba*, *Hàkea microcárpa*, *Lobèlia picta*, *Conràdia lasiántha Zuccar.*, *Thunbérgia alàta*, *Cecròpia palmàta*, *C. peltàta*, *Leycestèria formòsa*, *Strobilánthes Sabinì*, *Ficus religiòsa*, *F. péndula*, *Begònia fagifòlia*, *B. castaneifòlia*, *B. sanguínea*, *B. bulbífera*, *B. dipétala*, &c., *Tropæolum màjus fl. pl.* In the *Cácti* family, cuttings planted in charcoal were particularly successful. Of some hundred species that had been dried for some days previously in the air, about twenty succeeded perfectly; among these were *Echinocáctus pruinòsa*, *E. phyllacántha*, *Melocáctus mammillariæfórmis*, *Mammillària macrothèle*, *M. uberifórmis*, &c., many of them from 1½ to 2 or 3 in. in diameter. *Cèreus*, *Rhípsalis*, and *Epiphýllum* made no distinction in rooting; besides, in this short space of time, the roots of many species had grown 6 in. long, and the rooting was in general much more perfect than is usually the case. Other succulent plants, such as *Mesembryánthemum*, *Ròchea*, *Cotylèdon*, &c., rooted as quickly.

In from a fortnight to three weeks: *Piper nigrum*, *Chiocócça racemòsa*, *Amýris Unanùic*, *Búddlea madagascariénsis*, *Aster tomentòsus*, *Phyllánthus multiflórus*, *Cápparis longifòlia*, *C. frondòsa*, *Alnus denticulàta*, *A. barbàta*, *Ulex provinciàlis*, *Sálvia semiatràta Zuccar.*, *Mimòsa Hóústoni*, *Murràya exòtica*, *Barlèria hýstrix*, *Oxalis mandioccàna*, *Clerodéndron infortunàtum*, *Anacámpseros filamentòsa*, *Solànum xanthocánthum Mart.*, *Cordylíne Eschscholtziàna*.

In from three to four weeks: *Chamædòrea elàtior*, *Jacquínia mexicàna*, *Céstrum verbascifòlium*, *Cròton adenophýlla*, *Pandànus amaryllidifòlius*, *Carludovícia palmàta*, *Dracæna hùmilis*, *D. marginàta*, *Hernándia ovígera*.

In about six weeks: *Cálamus Dràco*, *Dombèya acerifòlia*.

In two months: *Pandànus útilis*. Both cuttings that were planted put forth thick side roots.

Some apology may be requisite for having introduced in this list many plants in most cases easy to strike; but this appeared to me to be necessary, partly on account of explicitness, and partly because opinions and experience vary as to plants being easy or difficult to root, and also because some of them made extraordinarily strong roots.

There is no doubt that many experiments did not succeed, but their number is so small in comparison with those that did, that no blame can be attached to this new method, when we consider

on how many circumstances the growth of a cutting depends. I did not succeed in rooting in this way some ericas and bignonias, *Plumièria angustifolia*, *Cereus columna Trajani*, *Vanguiera spec.* from Brazil, *Spondias dulcis*, *Illicium anisatum*, *Psoralea odoratissima*, *Aster argophyllus*, and some other plants, in which the cause of failure evidently lay in particular or outwardly unfavourable circumstances, which it was as impossible to remedy as it was to make them take root, such as sickly or old shoots, wet and consequent decay.

2. Leaves and parts of leaves of the following plants were rooted in charcoal.

It appears very remarkable to me that the peripherous forms of plants should display an extraordinary aptitude and inclination to form roots, so much so that half-leaves of *Peiréskia*, *Poliánthes mexicana Zuccar.*, and leaves of *Euphórbia fastuosa* in a short time filled their pots so full of roots that they were obliged to be repotted.

In from eight to fourteen days: leaves of *Cecropia palmata*, *Oxalis mandiocana*, *O. purpurea*, *Euphórbia fastuosa*, *Cyclamen indicum*, *Lophospermum scandens*, *Martynia craniolaria*, *Begonia monoptera*, *B. bulbifera*, *Ipomœa superba*, *I. spec. e Corcovado*, *Mesembryanthemum tigrinum*, *Gésnera latifolia*, *G. atrosanguinea*, *Sinningia guttata*, *Piper peireskiefolium*, all sorts of *Gloxinia*, even calyces and mere flower stems; pieces of leaves of *Convólulus Batatas*, *Peiréskia grandifolia*, *Poliánthes mexicana*, and warts of the large-warted *mammillaria*.

In three weeks: the tops of the leaves of *Agave americana fol. var.*, leaves of *Jacaranda brasiliensis*, bundles of leaves of *Pinus excelsa*, leaves of *Mimosa Houstoni*, and *Cyperus vaginatus*.

In five weeks, whole and half-cut folioles of *Encephalartos caffer* and *Zamia integrifolia* produced a number of roots from the surface of the cuts.

Many leaves have not yet made roots, but for a considerable time have formed callosities, such as *Laurus nitida*, *Bignonia Telfairia*, *Carolinea princeps*, *Ardisia*, *Gardenia*, *Adansonia digitata*, *Dracæna*, &c. As experiments that did not succeed, we may mention portions of the leaves of *Amaryllis* and *Crinum*, of ferns, of tropical *Orchideæ*, of *Dasyliiron* and *Héchtia*, *Tillandsia*, *Pandanus*, *Phormium tenax*, of tropical tuberous-rooted *Aróideæ*, old leaves of the *Agave*, and some others which, partly through rotting by wet, or other mischances, were prevented from growing.

It is to be wished, that, roused by this hint, many experiments may be tried with charcoal ashes, as in most cases, when not contrary to nature, I can guarantee success. I shall hereafter take the opportunity of laying before the public, as far as my experience goes, the good effects of charcoal as a cure for sick

plants, and how valuable it is when mixed with different sorts of earth for the growth of plants.

*Munich, Feb. 1840.*

[The theory of M. Lucas's experiments, by Dr. Buchner, will be given in our next Number.]

---

ART. VI. *On Gardening as an Art of Design and Taste.* By the late THOMAS HOPE, Esq.

[THE following essay was published upwards of twenty years ago, first in a work entitled the *Review of Art*, now very scarce, and subsequently in Hoffland's *Description of White Knights*, now also very scarce, and not to be had under two guineas a copy. The essay has been much admired, but, from the nature of the works in which it was published, never much read by those to whom it is calculated to be of most use, viz. country gentlemen and their gardeners. We intended some years ago to republish the essay in the *Gardener's Magazine*; and the late Mr. Hope, to whom we applied for permission to do so, very kindly promised to revise the proofs: but, unfortunately, we neglected to take advantage of his kind offer at the time, and before we could do so Mr. Hope died.]

It has been much the fashion of late years, in this country, to commend no feature in that production of human industry, a garden, which should not appear as if still remaining the mere spontaneous work of unassisted nature. It is become a very general custom indiscriminately to condemn, in the laying out of grounds, every marked trace of the hands of man; and, above all, every modification of intentional and professed symmetry.

Perhaps a more methodical enquiry than has hitherto been made into the purposes for which a garden has been destined, and into the character which, in conformity with these purposes, it ought to display, might have prevented its form and embellishments from being subjected to rules so confined and so narrow.

What was, in the earliest times, the origin of the garden? The wish that certain esculent plants and fruits which, in the waste field and the wide forest, are scattered at great distances in small quantities, intermixed with useless vegetables and fruits, precarious in their appearance and stunted in their growth, difficult to collect, and scarce worth the gathering, might, in a nearer, a smaller, and a more accessible spot, be better secured, more abundantly produced, and kept clearer of the noxious herbs and weeds which destroy their nutriment and impede their growth. This was, in its origin, the sole object of the entire garden; this, to the present hour, continues to be the

principal purpose of that essential portion of the garden devoted to the uses of the kitchen and the table.

In these parts of the garden, then, which are destined immediately for the gratification, not of the eye, but merely of the palate, it is only in proportion as we more fully deviate from the desultory and confused dispositions of simple nature, — firstly, by separating the different species of esculent plants, not only from their useless neighbours, but from each other; and, secondly, by confining the vegetables thus classed in those symmetric and measured compartments which enable us with greater ease to discover, to approach, and to improve each different species in the precise way most congenial to its peculiar requisites, — that we more fully attain that first of intellectual beauties, which, in every production, whether of nature or of art, resides in the exact correspondence between the end we purpose and the means we employ. Nay, if it be true that contrast and variety of colours and of forms are among the most essential ingredients of visible beauty, we may say that even this species of sensible charm is greatly increased in the aspect of a country, by the opposition to the more widely diffused but more vague shades and outlines of the unsymmetrised surrounding landscape, offered by the more vivid hues and more distinct forms of the gay mosaic work of nicely classed and symmetrised vegetables which clothe these select spots.

Even where the general unadorned scenery is as bold and majestic as in Switzerland, or as rich and luxuriant as in Sicily, the eye with rapture beholds the variety, and enjoys the relief, from the vaster and sublimer features of rude nature, offered by the professed art of a neat little patch of ground, whether field, orchard, or garden, symmetrically distributed. It looks like a small but rich gem, a topaz, an emerald, or a ruby, sparkling amidst vast heaps of ruder ore; or rather like a rich carpet spread out over a corner of the valley. It appears thus incontrovertible, that, in that part at least of the garden which is immediately intended for utility, we incidentally produce not only greater intellectual, but greater visible, beauty, by not confining ourselves to the desultory forms of unguided nature, but by admitting the more symmetric outlines of avowed art: and it therefore only remains to be enquired, whether in that other and different part of the artificial grounds in later times added to the former, which is directly intended for beauty, and which we therefore call the pleasure-grounds, we shall really produce more beauty, intellectual or visible, or, in other words, more pleasure to the mind or eye, by only employing the powers of art in a covert and unavowed way, in still only preserving the closest resemblance to the indeterminable and irregular forms of mere nature; or by adhibiting her additional resources in a more

open and avowed manner, in contrasting these more indeterminate and desultory features of pure nature with some of those more determinate and compassed outlines which, indeed, on a small scale, are already found in many of the spontaneous productions of Nature herself, but which, on a more extended plan, are only displayed in the works of art. I say, more pleasure to the mind or eye; for the portion of the garden here alluded to, no less than the one before mentioned, professes itself to be a piece of ground wrested from Nature's dominion by the hand of man, for purposes to which nature alone was inadequate; and thence, contending that there is the least necessity or propriety in rendering this district appropriated by art a facsimile of pure nature, independent of any consideration of superior beauty which this imitation may offer to the eye or mind, and merely because to form a garden we use materials supplied by nature, such as air, water, earth, and vegetables, would be absurd in the extreme. As well might we contend that every house built of stone should resemble a cavern, and every coat made of wool a sheepskin. Every production of human industry whatsoever must, if we trace it to its origin, arise out of one or more definite ingredients of pure nature; and unless, therefore, by the same rule, every production of human industry whatsoever be obliged everlastingly to continue wearing the less regular forms of those peculiar objects of nature out of which it is wrought, we cannot with more justice arraign gardens, in their capacity as aggregates of mere natural substances and productions, for assuming the artificial forms of a terrace or a jet-d'eau, an avenue or a quincunx, than we can condemn opera-dancers and figurantes, in their capacity of compounds of natural limbs and features, for exhibiting the artificial movements of the minuet and the gavot, the entrechat and the pas-grave.

If then the strict resemblance to the desultory forms of rude nature be not indispensably requisite in the artificial scenery of pleasure-grounds, on account of any invariable reasons of propriety or consistency inherent in the very essence of such grounds, this resemblance of studious art to wild nature, in the gardens that adorn our habitations, can only be more eligible on account of some superior pleasure which it gives the eye and mind, either in consequence of certain general circumstances connected with the very nature of all imitation, or only in consequence of certain more restricted effects, solely and exclusively produced by this peculiar species of imitation; namely, of natural landscapes through artificial grounds.

Now, with regard to the former of these two considerations, I allow that a faithful imitation, even of a deformed original, is capable of affording great intellectual pleasure to the beholder, provided that imitation, like those displayed in painting and

sculpture, be produced through dint of materials or tools so different from those of which is composed the original imitated, as to evince in the imitator extraordinary ingenuity and powers. But the imitation of a natural landscape, through means of the very ingredients of all natural scenery, namely, air, earth, trees, and water, (and which imitation will in general offer greater truth in proportion as it is attained through greater neglect,) cannot possess that merit which consists in the overcoming of difficulties and the display of genius, unless indeed it be an imitation of such a species of wild scenery as is totally foreign to the genius of the locality in which it is produced; unless it consists in substituting mountains for plains, waterfalls for puddles, and precipices for flats; and in that case, on the contrary, the attempt at imitation will become so arduous as to threaten terminating in a total failure, by only offering, instead of a sublime and improved resemblance, a most paltry and mean caricature. Since then, in a garden, the imitation of the less-symmetric arrangements of rude nature can afford little or no peculiar gratification to the mind, in their sole capacity as imitations, the question becomes restricted within a very narrow compass; and all that remains to be enquired into is, whether, in that garden, the exclusive admission of the mere unsymmetric forms of simple nature, or their mixture with a certain proportion of the more symmetric forms of professed art, will give more intense and more varied pleasure to the eye. And, when thus stated, I should think the question would be nearly answered in the same way by every unprejudiced person. I should think it would be denied by none, that, — if, on the one hand, the most irregular habitation, still, through the very nature of its construction and purposes, must ever necessarily remain most obviously symmetric and formal, if not in its whole, at least in its various details of doors, windows, steps, entablatures, &c.; and if, on the other hand, as I take it, all beauty consists in that contrast, that variety, that distinctness of each of the different component parts of a whole from the remaining parts, which render each individually a relief to the remainder, combined with that harmony, that union of each of these different component parts of that whole with the remaining parts, which render each a support to the remainder, and enable the eye and mind to glide over and compass the whole with rapidity and ease, — fewer striking features of beauty will be found in a garden where, from the very threshold of the still ever symmetric mansion, one is launched in the most abrupt manner into a scene wholly composed of the most unsymmetric and desultory forms of mere nature, totally out of character with those of that mansion, and where the same species of irregular and indeterminate forms already prevailing at the very centre extend without break or relief to the



utmost boundaries of the grounds, than will be presented in another garden, where the cluster of highly adorned and sheltered apartments that form the mansion, in the first instance, shoot out, as it were, into certain more or less extended ramifications of arcades, porticoes, terraces, parterres, treillages, avenues, and other such still splendid embellishments of art, calculated by their architectural and measured forms at once to offer a striking and varied contrast with, and a dignified and comfortable transition to, the more undulating and rural features of the more extended, more distant, and more exposed boundaries; before, in the second instance, through a still further link, a still further continuance of this same gradation of hues and forms, these limits of the private domain are again made in their turn, by means of their less artificial and more desultory appearance, to blend equally harmoniously, on the other side, with the still ruder outlines of the property of the public at large.

No doubt, that, among the very wildest scenes of unappropriated nature, there are some so grand, so magnificent, that no art can vie with or can enhance their effect. Of this description are the towering rock, the tremendous precipice, the roaring cataract, even the dark, gloomy, impenetrable forest. Of such, if we be fortunate enough to possess any specimens in the more distant parts of our domain, let us take great care not to destroy or to diminish the grandeur by paltry conceits or contrivances of art. But even these are such features as, from certain conditions unavoidably attendant on them, we would not wish to have permanently under our eyes and windows, or, even if we wished it, could not transport within the narrow precincts which immediately surround the mansion. A gentleman's country residence, situated in the way it ought to be, for health, for convenience, and for cheerfulness, can only have room in its vicinity for the more concentrated beauties of art. In this narrow circle, if we wish for variety, for contrast, and for brokenness of levels, we can only seek it in arcades and in terraces, in steps, balustrades, regular slopes, parapets, and such like; we cannot find space for the rock and the precipice. Here, if we admire the fleeting motion, the brilliant transparency, the soothing murmur, the delightful coolness of the crystal stream, we must force it up in an erect jet-d'eau, or hurl it down in an abrupt cascade; we cannot admit so near us the winding torrent, dashed at wide intervals from rock to rock. Here, if we desire to collect the elegant forms, vivid colours, and varied fragrance of the choicest shrubs and plants, whether exotics or only mere natives, oranges, magnolias, and rhododendrons, or mere roses, and lilies, and hyacinths, we still must confine them in the boxes, the pots, or the beds of some sort of parterre; we cannot give them the

appearance of spontaneously growing from amongst weeds and briars. Here, in fine, if we have a mind to secure the cool shade and the convenient shelter of lofty trees, we can only plant an avenue, we cannot form a forest. And for what reason, since we admire, even to an excess, symmetry of lines and disposition in that production of art called a house, we should abhor these attributes in the same excess in that other avowed production of art, the immediate appendage of the former, and consequently the sharer in its purposes and character, namely, the garden, I do not understand.

There is between the various divisions of the house and those of the grounds this difference, that the first are more intended for repose, and the latter for exercise, that the first are under cover, and the latter exposed. This difference should make a corresponding difference in the nature of the materials, and in the size and delicacy of the forms; but why it should occasion on the one side an unqualified admission, and on the other as unqualified an exclusion, of those attributes of symmetry and correspondence of parts which may be equally produced in coarser as in finer materials, on a vaster as on a smaller scale, I cannot conceive. The outside of the house is exposed to the elements as well as the grounds; and why, while columns are thought invariably to look well at regular distances, trees should be thought invariably to look ill in regular rows, is what I cannot comprehend. Assuredly the difference is as great between the eruptions of Etna or of any other volcano and artificial fireworks, as it is between the falls of the Niagara or of any other river and artificial waterworks. Why then, while we gaze with admiration on a rocket, should we behold with disgust a jet-d'eau? And why, while we are delighted with a rain of fiery sparks, should we be displeased with a shower of liquid diamonds issuing from a beautiful vase, and again collected in as exquisite a basin? If the place be appropriate, if the hues be vivid, if the outlines be elegant, if the objects be varied and contrasted, in the name of wonder, how should, out of all these partial elements of positive unmixed beauty, arise a whole positively ugly? No, there can only arise a whole as beautiful as the parts; and so those travellers who have not allowed any narrow and exclusive theories to check or destroy their spontaneous feelings, must own they have thought many of the suspended gardens within Genoa and of the splendid villas about Rome: so they have thought those striking oppositions of the rarest marbles to the richest verdure; those mixtures of statues, and vases, and balustrades, with cypresses, and pinasters, and bays; those distant hills seen through the converging lines of lengthened colonnades; those ranges of aloes and cactuses growing out of vases of granite and of porphyry, scarce more

symmetric by art than these plants are by nature; and finally, all those other endless contrasts of regular and irregular forms, every where each individually increasing its own charms, through their contrast with those of the other; exhibited in the countries which we consider as the earliest schools where beauty became an object of sedulous study.

But the truth is, that, in our remoter climes, we carry every theory into the extreme. Once, that very symmetry and correspondence of parts, of which a certain proportion ever has, to all refined ages and nations, ancient and modern, appeared a requisite feature of the more dressy and finished parts of the pleasure-garden, prevailed in our English villas with so little selection, and at the same time in such indiscreet profusion, as not only rendered the different parts insipid and monotonous with respect to each other, but the whole mass a most formal unharmonious blotch with regard to the surrounding country. Surfeited at last with symmetry carried to excess, we have suddenly leaped into the other extreme. Dreading the faintest trace of the ancient regularity of outline as much as we dread the phantoms of those we once most loved, we have made our country residences look dropped from the clouds in spots most unfitted to receive them; and, at the expense, not only of all beauty, but of all comfort, we have made the grounds appear as much out of harmony, viewed in one direction with the mansion, as they formerly were, viewed in the opposite direction with the country at large. Through the total exclusion of all the variety, the relief, the sharpness, which straight, or spherical, or angular, or other determinate lines and forms might have given to unsymmetric and serpentine forms and surfaces, we have, without at all diminishing the appearance of art (which in a garden can never be totally eradicated) only succeeded in rendering that art of the most tame and monotonous description, like that languid and formal blank verse which is equally divested of the force of poetry and the facility of prose. Nature, who, in her larger productions, is content with exhibiting the more vague beauties that derive from mere variety and play of hues and forms. Nature herself, in her smaller and more elaborate, and, if I may so call them, choicer bits of every different reign, superadds those features of regular symmetry of colours and shapes, which not only form a more striking contrast with the more desultory modifications of her huger masses, but intrinsically in a smaller space produce a greater effect than the former can display. Examine the radii of the snow-spangle, the facettes of the crystal, the petals of the flower, the seeds of the capsule; the wings, the antennæ, the rings, and the spots of the larva and the butterfly; nay, even in man and beast, the features of the face, and the configuration of the eye; and we shall find in all these

more minute, more finished, and more central productions of the mineral, the vegetable, and the animal kingdoms, reigns the nicest symmetry of outline and correspondence of parts. And if Art, which can only be founded upon, only spring out of Nature, if Art, I say, should ever only be considered as the further developement of Nature's own principles, the complement of Nature's own designs, assuredly we best obey the views of Nature, and best understand the purposes of Art, when, leaving total irregularity to the more extended, more distant, and more neglected recesses of the park, we give some degree of symmetry to the smaller, and nearer, and more studied divisions of the pleasure-ground. This principle of proportioning the regularity of the objects to their extent, the Greeks well understood. While in the Medici Venus the attitude of the body only displays the unsymmetric elegance of simple nature, the hair presents all the symmetry of arrangement of the most studious art; and unless this principle also become familiar among us there is great danger that, unable to make the grounds harmonise with the mansion, we attempt to harmonise the mansion with the grounds, by converting that mansion itself into a den or a quarry.

Economy, no doubt, may sometimes be alleged as an unanswerable reason for leaving even the most important and dignified of our country mansions entirely destitute of the accompaniments of covered walks, terraces, balustrades, parterres, berceaux, and such like works of art and nature combined; but that taste should be made the pretence for wholly discarding those numerous additional means of increasing the splendour and the variety of the scene, is an abuse of terms as egregious as it seems inconceivable.

---

ART. VII. *Remarks on several Species of Coniferæ, with Reference to the Climate of North Britain.* By JOHN GRIGOR, Forres Nurseries.

OF the many species of Coniferæ which have been introduced into Britain within the last twenty years, it is questionable whether any, or all of them collectively, will yield so beneficial a result to this country as that which is now known to arise from the introduction of the *Làrix europæa*, or common larch. Although I have a high opinion of many of the new pines, yet I do not think that, from what we know of them at present, this question can be satisfactorily answered. It is, however, already apparent, that whatever qualities many of those of recent introduction may possess, scarcely any of them appear to afford, in an equal degree, the means of being propagated with facility. From the natural bareness of their roots, few of them are so well adapted to be grown in seed-beds, and safely transplanted

from thence into moorland, as the larch. Seldom does a specimen of this tree arrive at the age of twenty years without producing several crops of cones; and it is not uncommon for a tree of that age to yield, in one season, seeds sufficient to raise several thousand plants. The larch, when young, is also remarkable for its readiness to strike root into the ground immediately on being transplanted; so much so, that in no degree is its growth interrupted if planted in a suitable soil. Hence, a plant of the age of three years, having been twice removed, is frequently as large and vigorous as one of the same age which has grown under any other circumstances. These are properties which, in Britain, we cannot yet ascribe to any other timber tree, either indigenous or foreign.

The most useful tree in Scotland is, without doubt, the native Highland pine. The larch ranks next to it, and although the timber of the latter, from its liability to warp, will never be in general use for flooring or many other purposes of the carpenter, yet its rapidity of growth, and fitness for ship-building at so early an age, render its cultivation in proper soil more profitable than that of any other tree.

When time shall have tested the numerous species of Himalayan and American pines now new to this country, some of them may be found as famous for timber as they now are for ornament. Of the former, the most beautiful, as well as the most promising in our northern regions, is the *Cèdrus Deodàra*. Seedling plants of this tree grow here in the open ground to the height of 4 or 5 inches during the first summer, and resist the frosts of winter, auguring well of their future prosperity. In the shires of Inverness and Ross, where it is considered to be quite hardy, there are several fine specimens of this tree. Its figure is that which is best adapted to a mountainous district, well furnished with branches from the surface of the ground upwards, and tapering into a conical form. The leaves of vigorous trees are of a silvery green, of the most delicate shades, whilst the entire tree is rendered graceful from the young branches being pendulous. At a distance, its outline and appearance may be compared to spray falling around the column of some ornamental fountain; in short, it is altogether different in its habit from any other evergreen tree grown in our climate. By the Hindoos it is considered sacred; and, according to Dr. Royle, it is the most celebrated ligneous production of the country to which it belongs.

The *Pinus excèlsa* is a native of the same part of the world, and young plants grown here appear quite suited to the climate.

*Pinus ponderosa*, a native of North America, grows in the North of Scotland with great vigour, and resists the severest frosts; but all the older specimens in this quarter have become

top-heavy, and require support. It is, besides, much infested with a small beetle of the genus ? *Hylurgus*, which perforates longitudinally the more luxuriant shoots of one year's growth. The largest specimen of it in this quarter has thus been destroyed, although placed on a lawn at a distance from any other tree. Unless these casualties, to which this plant is particularly subject, can be overcome by sowing the seed where the tree is destined to remain, or by planting it at a very early age into poor soil, where it may become more fixed and spreading, and produce young shoots less luxuriant, and consequently of a harder texture, its vigorous habits will be of little avail.

*Abies Douglàssi* is likewise of very rapid growth here, some of the largest trees having produced top shoots in one summer 3 ft. in length; and, like *Picea pectinàta*, the plant becomes well-rooted and furnished with lateral branches before it produces strong leading shoots, so that it is not subject to be blown over. I fear, however, this species is not sufficiently hardy for our climate. Some fine plants of it, situated in the higher districts of Morayshire, grew luxuriantly for several years previous to the autumn of 1838, when they produced a profusion of second shoots (such as are common on the oak and beech, and known here by the title of Lammas growths), which, being overtaken by the frosts, were so cut up that the plants perished. From this tree being in the habit of growing at such a late period of the year, it is supposed to be adapted only to the most favourable situations in this country.

Concerning the suitability of other species of the *Coníferæ* more recently introduced into this quarter, all is conjecture.

In the extensive plantations of Sir W. G. G. Cumming, Bart., which are now in progress of being formed on the moorland of some of the most elevated hills of the Altyre estate, a considerable number of Himalayan pines are to be introduced. At Dalvey, the *C. Deodàra*, *P. excélsa*, *P. Webbiàna*, and many of the most promising kinds, are extensively grown. The proprietor of this estate, Norman Macleod, Esq., has done much for the improvement of gardening in the north, and his example in this instance cannot fail to have a powerful effect in advancing the important interests of arboriculture.

Though I cannot speak decidedly of the merits of those new pines as timber trees in the climate of Britain, it does not follow that their cultivation is rendered the less interesting or necessary. It is probable that about the beginning of next century, when the various kinds shall have been fully tried and known, some of the Himalayan and American sorts will rank as high, and be as eagerly cultivated for valuable timber, as our best European kinds now are, not excepting even the Highland pine.

*Forres, Jan. 1841.*

ART. VIII. *Botanical, Floricultural, and Arboricultural Notices of the Kinds of Plants newly introduced into British Gardens and Plantations, or which have been originated in them; together with additional Information respecting Plants (whether old or new) already in Cultivation: the whole intended to serve as a perpetual Supplement to the "Encyclopædia of Plants," the "Hortus Britannicus," the "Hortus Lignosus," and the "Arboretum et Fruticetum Britannicum."*

*Curtis's Botanical Magazine*; in monthly numbers, each containing seven plates; 3s. 6d. coloured, 3s. plain. Edited by Sir William Jackson Hooker, LL.D., &c., Professor of Botany in the University of Glasgow.

*Edwards's Botanical Register*; in monthly numbers, new series, each containing six plates; 3s. 6d. coloured, 3s. plain. Edited by Dr. Lindley, Professor of Botany in the University College, London.

*Maund's Botanic Garden, or Magazine of Hardy Flower Plants cultivated in Great Britain*; in monthly numbers, each containing four coloured figures in one page; large paper, 1s. 6d.; small, 1s. Edited by B. Maund, Esq., F.L.S.

*The Botanist*; in monthly numbers, each containing four plates, with two pages of letterpress; 8vo; large paper, 2s. 6d.; small paper, 1s. 6d. Conducted by B. Maund, Esq., F.L.S., assisted by the Rev. J. S. Henslow, M.A., F.L.S., &c., Professor of Botany in the University of Cambridge.

*Paxton's Magazine of Botany, and Register of Flowering Plants*; in monthly numbers; large 8vo; 2s. 6d. each.

*The Ladies' Magazine of Gardening*; in monthly numbers; 8vo, with coloured plates; 1s. 6d. each. Edited by Mrs. Loudon.

*Ranunculaceæ.*

1622. ANEMONE 14400 cernua Ladies' Mag. of Gard. t. 2. fig. 1.

*Papaveraceæ.*

1552. PAPAVER commutatum Fisch. et Mey. changeable O or 1 au. s S Siberia 1839. S co. Bot. gard. [776.

A pretty showy annual poppy, which will probably prove a variety of *P. Rhæas*. (*Bot. Gard.*, Feb.)

*Leguminosæ.*

2136. LATHYRUS tomentosus West. woolly Δ pr 3 su Li Buenos Ayres 1839. D s.1 Bot. 206.

A rather elegant plant, with pale lilac flowers, and glaucous silky leaves. It should be grown in light rich soil, "and, if it be planted against a south wall, it will flower freely; but, if planted in a stiff soil, it will be very liable to damp off." (*Botanist*, Feb.)

*Onagrariæ.*

1183. ÆNOTHERA 10021 fruticosa var. indica Bot. Reg. 1841, 11.

A very handsome Indian variety of this well-known species. "Its leaves are less shining than in the species; the corymbs of flowers are never elevated above the leaves on a long stalk, and the herbage forms a compact little bush, about a foot and a half high." (*Bot. Reg.*, Feb.)

*Compositæ.*

\* BRACHYCOME Cass. SWAN DAISY. (*Brachus*, short, *komē*, hair; shortness of the pappus.)  
iberidifolia Benth. Iberis-leaved O or  $\frac{1}{2}$  su P Swan River 1840. S co. Bot. reg. 1841, 9.  
M 4

A very beautiful dwarf annual, the flowers of which vary from dark purple to lilac, the colour deepening according to the length of time the flower has been expanded. "It flowers freely in the open border, but is impatient of wet; at the latter end of the season it may, however, be lifted and transferred to the greenhouse, where it will go on flowering beautifully." (*Bot. Reg.*, Feb.)

OBELISCA'RIA *Cass.* (*Obeliskos*, obelisk, *kara*, head; elevated disk of flower.) *Drummóndii* *Grah.*  
*Synonyme*: *Rudbeckia Drummóndii* *Paxt.* vol. vi. p. 51. (*See Gard. Mag.*, vol. xv. p. 244.)

This very handsome plant, which was introduced by Drummond, is one of those removed by Cassini "from the heterogeneous assemblage of plants which were formerly included under the name of Rudbeckia, and the character by which it may be distinguished seems perfectly good." (*Dr. Graham in Botanist*, Feb.)

#### *Asclepiadææ.*

STEPHANO'TIS *Du Petit Thouars.* (*Stephanos*, crown, *ôtōeis*, eared; auricles of staminal crown.)  
*floribúnda* *Ad. Brong.* many-flwd  $\text{R} \square$  or 6 my. W Madagasc. 1839. C p.l *Botanist*, 203.

A splendid evergreen climber, with dark green coriaceous leaves somewhat like those of *Ficus elástica*. Though of comparatively late introduction, it is already common in our stoves, of which its large bunches of fragrant white flowers render it a conspicuous ornament. (*Botanist*, Feb.)

#### *Solanæcææ.*

SOLAN'NUM  
*macranthèrum* *Dun.* large-anthered  $\text{R} \text{✱} \square$  or 3 s P Mexico 1838. C c *Bot. reg.* 1841, 7.  
*Synonyme*: *S. dulcamaróides* *Poir.*

A very showy species, raised by Mr. Page of Southampton, from Mexican seeds. It is "a fine half-shrubby greenhouse plant, with large clusters of deep purple flowers, whose centre is occupied by a knot of large bright yellow anthers. It appears to be nearly allied to the common bitter-sweet, and in Mexico is of the same habit of growth." The plant that flowered with Mr. Page was, however, a bush about 3 ft. high. (*Bot. Reg.*, Feb.)

[*of Bot.* vol. viii. p. 5.

*jasminóides* *Hort.* Jasmine-like  $\text{R} \square$  pr 6 au. d Pa. P S. Amer. 1838. C s.l *Paxt. mag.*

An evergreen climbing Solanum, with clusters of small pale purple fragrant flowers. It flowered in the Epsom Nursery, in a pot in a camellia house, in 1839, continuing in flower from August till December. The following year it was planted out, and continued flowering freely till killed down to the ground by frost. (*Paxt. Mag. of Bot.*, Feb.)

#### *Orchidæcææ.*

2540. ONCIDIUM  
*Wrayæ* *Hook.* Mrs. Wray's  $\text{Y} \square$  or 2 Y.B Mexico 1838. D p.r.w *Bot. mag.* 3854.

A pretty yellow and brown *Oncidium*, with a long spike of rather large flowers. Introduced by Mrs. Wray of Oakfield, near Cheltenham. (*Bot. Mag.*, Feb.)

3722. HUNTLEYA 31623. violácea *Paxt. Mag. of Bot.* vol. viii. p. 1.

#### *Musæcææ.*

746. MU'SA 6064. supérba *Bot. Mag.* 3849, 3850.

#### *Amaryllidæcææ.*

935. ISME'NE  
*viréscens* *Lindl.* greenish  $\text{Y} \triangle$  or 1 jn. au Gsh Cusco 1840. O l.p.s *Bot. reg.* 1841, 12.

An elegant plant, which is ornamental, notwithstanding its greenish flowers. It should be kept in a greenhouse, where it "flowers from June to August. The leaves wither soon after flowering, when it must be kept perfectly dry till spring." (*Bot. Mag.*, Feb.)

#### *Liliæcææ.*

1045. SOWERBÆA  
*laxiflóra* *Lindl.* loose-flowered  $\text{Y} \triangle$  pr 1 my. j.l Pk Swan River 1839. R s.p *Bot. reg.* [1841, 10.

This species differs from *S. júncea*, principally in the flowers being on long slender stalks, which renders the general appearance of the plant much more ornamental. The leaves are also triangular, and "nearly as long as the scapes." (*Bot. Reg.*, Feb.)



ART. IX. *On the Management of Cacti.* By N. M. T.

IN managing cactoid plants, particularly the *Cereus* tribe, it is customary to give them, while blooming, a more liberal supply of water than at other times, but experience has convinced me that this is sometimes injurious in some species. In the spring of 1838, a plant of the *Cereus hexagonus* under my care showed flower buds; when I applied a little more moisture, and had the mortification to see the buds turn black, and drop when about the size of peas. In the autumn of the same year it again produced flower buds, and the same treatment had again the same effect. This determined me to pursue a different method; and, as soon as it showed flower in 1839, I withheld water entirely; the buds continued to swell rapidly, and the whole number (five) expanded beautifully; and, in 1840, no less than fourteen of its fine large ephemeral flowers arrived at the greatest perfection.

This plant is, I believe, generally deemed a shy bloomer, and from the liability of the buds to drop when very small (if water is supplied), it is probable its flower buds are often imperceptibly sacrificed, and a knowledge of these facts may lead to greater vigilance. Much has been attributed to the influence of light in causing these plants to flower; but the plant mentioned would indicate that a certain age, or maturity of organisation, is the only requisite (plenty of light may sooner produce the latter certainly), as its great height causes it to be placed in the back of a vinery, where it is densely shaded during the blooming season.

When a hypothesis appears that seems reasonable, and has passed current for a time, we are too apt to adopt it without questioning its validity, or bringing proof to its support. So it is with some of the effects attributed to light; for instance, plants taken from the protection of glass, and exposed to the open air, are said to become discoloured from its direct influence, but this is not the case. Take a plant from a warmer to a colder climate, from a stove to a greenhouse, where the light is equally indirect, equally qualified, and the same effect is produced as if taken from the shelter of glass to the open air; demonstrating that it is produced by change of temperature only. Of this, last spring afforded me convincing proof. During March I turned out several things, and planted them in a sheltered corner (in the manner described in a paper at the time), to enable them to get rid of this discolouration previously to their being planted out in beds fully exposed to the sun. In April, which was intensely hot, they soon assumed the unspotted hue of perfect health, while the cold, cloudy, unseasonable weather that suddenly followed, in a few days turned them as "brown as berries." Light has no hand whatever in producing this appearance. Cold pro-

duces the same effect, and by the same means, upon animal bodies. Exposed to it, under certain circumstances, these soon become black and blue. This appearance, caused by the stagnation of a coloured fluid under a semi-transparent surface, is easily accounted for; that the discolouration of plants proceeds in like manner from a stagnation of fluids is evident: but why the stagnation of a colourless fluid should become so apparent, I cannot easily imagine.

*Folkstone, Jan. 19. 1841.*

ART. X. *On the Shriveling of Grapes.* By ROBERT ERRINGTON.

I HAVE just been reading Mr. Duncan's paper on the vine, p. 21. of your January Number. It is in my opinion replete with good sound information, and I must say, for one, I have derived both amusement and instruction from it. There are also several papers on the shriveling or shanking of grapes, by various persons, anonymous and otherwise, in which the opinions are at once so various and conflicting, that horticulture as a science must appear in the eyes of learners a complete chaos.

This subject has now been discussed in the *Gardener's Magazine*, I should think, a hundred times, and appears as far from settlement as ever; therefore I trust I also may be allowed to make a few remarks. It is said by one of your correspondents, that Dr. Lindley was of opinion that it arose from the discrepancy, in point of temperature, between the border outside and the atmosphere within. Such disagreement, we know, must inevitably have a pernicious influence on any tree, but still this alone will not, in my opinion, account for it; inasmuch as I have known it occur every year, for a series of years, in houses in which the grapes were started at their natural period. Your correspondent, Mr. R. Wilson, too has had a vinery in which, whilst the atmosphere in the house was West Indian, the roots were at the same time undergoing all the rigours of a Siberian winter. Now this he has done three successive years, and not only with impunity, but he has (as he states) thereby obtained the medal at the Jedburgh Society. Now, this is most astounding, especially if the inference I draw be right, viz. that he must have commenced forcing them in December, which fact he has omitted to state. Your correspondent of Cotswold talks about fermentation in the berries, in consequence of thinning too early; but, unfortunately for his theory, some of the best grape-growers in Britain produce splendid fruit by this early thinning.

By the by, I cannot understand what the last-named correspondent means by "fermentation" in the berries in consequence

of early thinning; it appears to me to savour of what is called "jumping at conclusions." Again, he says that the cambium does not begin to descend until the berries have done stoning; this appears to me to be quite unwarrantable, and totally unsupported by facts. I believe that the cambium, or returning sap, begins to return the moment the leaves are fully developed, and numberless operations in gardening, I think, bear me out in that opinion; however, if wrong, I shall be glad to be set right in so important a matter.

In my opinion, shanking may be caused either by stagnation at the roots, or by a sudden declension of heat, at that important period for the fruit, the time of changing colour, or by both causes combined. I believe that, under favourable circumstances, the action of the root in the Frontignan vine is more rapid than in many other kinds. It at the same time, also, is much more susceptible of injury, especially from excess of moisture, and consequent stagnation. Now, whatever arrests the vigorous and free action of the roots in this vine will quickly manifest itself in the fruit. The causes may be various: for instance sudden variations of atmosphere (not at all unfrequent in Britain); deluges of rain, defeating for a time even the best of drainage; and last, but not least, the want of abundance of heat and light on a healthy and well exposed foliage at that period (important indeed) when the berries first begin to change colour. Frontignans in pots on the back shelves of pineries seldom or never shank, at least I never saw them. Radiation from the glass in the night, in capricious seasons, is not taken sufficiently into account; and I venture to prophesy that the day is not far distant when night coverings will be deemed indispensable, as being favourable both to vegetation and economy.

*Oulton Park Gardens, Feb. 1. 1841.*

---

---

ART. XI. *On the Shriveling of Grapes.* By W. H.

As the shriveling of grapes is a subject in which all grape-growers must be interested, I beg leave to make a few remarks in answer to your various correspondents in this month's [January, 1841] Magazine, hoping that they will lead to further elucidation, as the subject seems to be still in doubt and obscurity.

Mr. Wilson does not say when he commenced forcing; this is a very material point, as borders for early forcing cannot be made too rich. The vines being excited at an unnatural season, there is no danger of their taking up more food than they can digest, and the berries are therefore free from shriveling. The leaves, also, are not half the size or thickness of vines excited in the growing season, consequently they require less light to

elaborate their sap. If we had a command of light the same as we have of heat, then we might make the borders as rich as we liked; but, as our supply of light is limited, it is certainly wrong to supply more food than they have light to properly digest.

The suggestion of your Cotswold correspondent is, I think, worthy of attention. Leaving all the berries on the bunches leaves more channels for the distribution of the cambium, and may be the means of preventing the disease; but, if the early thinning of grapes causes the disease, how is it that the early forced vines, which are pruned and thinned exactly in the same way as the later ones, are not subject to it? And how is it that late vines which are grown under glass without any artificial heat are not subject to it? The time of beginning to force has, in my opinion, a great deal to do with the shriveling of the berries, as I have proved by experience.

J. B. W. and I are of diametrically opposite opinions: he says that want of food is the cause; and I, that the cause is overabundance of food. We therefore cannot both be right. As the disease makes its appearance only in dull cloudy seasons, I am led to conclude that more food is supplied than the leaves have light to decompose; and that this superabundance of crude sap causes a stagnation to take place throughout the whole plant, in consequence of which the fruit ceases to advance, and shriveling commences.

This, in a few words, is my opinion; and, until I see a better propounded, I shall adhere to it. My borders are well drained, and made with turf taken from the deer park, mixed with road sand, hotbed manure, leaf-mould, and coarse lime rubbish, mixed well together, not chopped fine, but left rough to keep the borders open and porous. The roots are close to the surface, and the borders are never dug, but merely forked over about a couple of inches deep to admit the air. They are thatched early in autumn, to protect the spongioles from the heavy rains of autumn and winter. This I consider an essential point in vine culture, where the vines are planted outside. They are pruned upon the spurring system: one rod is allowed to each rafter, and the spurs are cut to one eye. My rafters are 15 ft. in length: to each rafter I allow eight bunches of Hamburgs, Frontignans, Muscadines, and Sweetwaters; six of the Muscats; and four of the Syrian. To reduce the bunches to this number, I have to cut off from twenty to thirty bunches from each rafter. My berries are from 3 in. to  $3\frac{1}{2}$  in., and some few 4 in. in circumference, and well coloured. The vines have been planted twenty years next June, and their stems measure from 5 in. to 8 in. in circumference, according to the sorts. I state this to show J. B. W. that my vines have not been grown

upon the starving system, and that I am neither sparing of the knife nor the scissors; yet in dull seasons the footstalks of the grapes will turn black notwithstanding.

*Marley Hall, Jan. 14. 1841.*

---

ART. XII. *On the Shanking and Shriveling of Grapes.*

By a GARDENER OUT OF PLACE.

I HAVE read with much interest the articles that have appeared at different times in your Magazine on the culture of grapes; and the various opinions given respecting the shanking of the bunches, and the shriveling of the berries. I have had for the last twenty years to attend to three or four houses of early forced grapes, thinning them out, &c.; and the conclusion I have arrived at is, that the shriveling of the berries may be traced to the sap in the stalk of the berry accumulating on the points of the scissors, when thinning them out; which sap, if the scissors are not kept perfectly clean, and very frequently wiped dry, gets impregnated with iron so as to turn quite black. As you proceed in thinning, to every wound you make, a layer of this iron extract is left on the stump of the stalk of the berry, which I consider poisons the part, thus "destroying or greatly weakening the principle of vitality."

I may be right or wrong in this conjecture; but, if the observation of your Cotswold correspondent, "that he never saw a bunch shank that the scissors had been kept from," is correct, it will in some measure seem to sanction this opinion.

I consider Mr. Duncan, in his clever essay, decidedly wrong in stating that "syringing should be continued till the berries have done growing." The grape-growers who grow for the market, and who may be considered the best practical men in the line, *never syringe their vines after the bunches are in blossom.* The stems they do syringe, but the stems only. By syringing the bunches, you wash off that beautiful bloom which, in the ripe grape, adds so much, not only to their appearance on the table, but to their pecuniary value in the market; and which, when once it is gone, can never after be recovered. Syringing, also, will very frequently make the bunches spotty; as, if there is the least impurity in the water, not perceptible to the naked eye, it is sure to be exhibited on the berries, "growing with their growth," rendering them unsightly, and reducing them very considerably in estimation. The best way to colour grapes is to give plenty of air, and as early in the morning as you possibly can. Some leave a little all night; this may be unnecessary, but no consideration must tempt you to neglect it in the morning, full as early as 7 o'clock: if the weather is any way favourable it must be attended to, for, if neglected, a damp vapour

arises in the house, and settling on the grapes makes them appear covered with dew, but in reality poisons them; and is, no doubt, when carried to excess, one main cause of the partial shanking of the bunches. By giving air to the top lights early, this vapour escapes, and the air in the interior of the house is purified, and rendered fit to be inhaled by the vines.

Gardeners who are too greedy prevent their grapes sometimes from colouring, by overloading the vines with bunches. This is a great error. A vine with its clusters of grapes may be compared to a sow with a large farrow of young pigs; if too many are left to draw her nutriment, they all suffer. To give plenty of water, more especially in dry weather, when grapes are swelling off, may be considered good practice, as the vine is a plant which will not only "drink deep," but "again and yet again."

If these remarks, drawn from a long experience, be published in your Magazine, they may possibly elicit some of a more valuable kind from others of your correspondents, who are more favourably situated for observation than "A Gardener out of Place."

*Camberwell, Jan. 25. 1841.*

---

ART. XIII. *On the Culture and Forcing of Rhubarb.*

By R. A. WILSON.

I BEG leave to lay before you the following remarks on the culture and forcing of rhubarb, it being an article in much demand in the winter and early spring months, when gooseberries, &c. cannot be obtained unless in a preserved state; and few vegetables are more improved by being blanched than rhubarb, independently of its medicinal properties, which, I may say, render it beneficial to the majority of constitutions; but, putting that out of the question, there are few persons indeed who do not admire it in the shape of a tart in the early part of the spring. But it is unnecessary to enlarge on the merits of a vegetable so generally known; suffice it to say, that, possessing such merits as it does, it is not surprising that so many methods are tried to grow and force it to perfection, and to lengthen its season to the utmost extent; and there are few vegetables that the gardener has been more successful with than the article before us. Nevertheless there are many instances where the forcing of rhubarb is very improperly managed, when neither materials nor conveniency are wanting, such as plenty of spare litter, &c. &c.; yet how frequently do we see rhubarb roots taken up and stored in cellars or back sheds, and forced in pots, as recommended by Mr. Knight, when such exuberant forcing agency is at hand, by the aid of which it might be forced in a superior manner.

Rhubarb is found to succeed pretty well in most garden soils;

but it grows to the highest perfection in strong turfy loam, well trenched and profusely enriched with horse-dung and decayed succulent vegetable leaves, putting the roughest dung in the bottom of the trench, and the rottenest towards the surface. I would also recommend rhubarb plants to be oftener transplanted than they generally are, as it is proved beyond a doubt that this vegetable attains a much greater degree of perfection for culinary purposes by frequently undergoing that process. When wanted for medicinal purposes, however, the case is widely different, in consequence of the root not attaining all its medicinal properties till it is ten or eleven years old; consequently the less it is disturbed the better, and the foliage must also remain untouched.

As to the manner of forcing it, there are numerous systems in practice, this emboldens me to lay before you the plan which I have followed pretty successfully; I do not mean to say that it is new, but it certainly is not generally adopted in this part of the country. In place of the general system of blanching it under sea-kale pots, I would recommend square boxes, 2 ft. square and 4 ft. high, open at both ends, with a cover for one end of each, placing a box on each root; the roots must be 4 ft. apart in the row, and 5 ft. between the rows, to admit of linings of hot dung in such a state of fermentation as when used for cucumber frames, putting a little rough litter at the bottom, to prevent the hot dung from injuring the roots, which would cause the stalks to draw up weakly. As soon as the linings get cold and sunk, they must be renewed, by adding a little fresh litter, and mixing it with the old, making the lining as high as the box, and putting a little on the cover. Two linings, in the generality of cases, will be sufficient to force the stalks as high as the box; and, if not too rapidly stimulated by exuberant heat, the stalks will be stouter by this method of forcing than by any other that I am aware of. When it is not a matter of consequence to have the stalks so very stout, more can be obtained from a given space of ground, by having the plants considerably less apart from each other in the row, and constructing a sort of skeleton span roof over the row, by means of stout upright stakes 6 ft. apart, stuck into the ground on each side of it and joined at the top; upon these rails are to be nailed 8 in. apart the long way of the row, and then thatched all over with a good lining of hot dung, renewing it as occasion requires. The stalks, of course, will not be so stout as they can be obtained by the other system, which is adopted by many eminent gardeners in the South of Scotland.

There are many places, however, where the gardener has not dung at command for the forcing of early rhubarb, when recourse must be had to taking up the roots with as large balls

as possible, and plunging them in any convenient spot in any forcing-house at work; shading them, and giving them plenty of water. Should there not be a forcing-house at work, it will not require much dung to force a small quantity in a frame in the same manner as asparagus; or in a vault made under a cucumber frame, as prescribed by Mr. Smith in his *Treatise on the Cucumber and Melon*, which, if followed up, will succeed admirably, either with or without the asparagus frame. When none of these conveniences can be had, it will succeed in a warm cellar, or in any other spare house where the temperature is a little above that of the open air. To those who prefer the flavour of green rhubarb, the addition of a little acid juice or lemon peel will answer the purpose.

Norton, Jan. 20. 1841.

## REVIEWS.

ART. I. *Catalogue of Works on Gardening, Agriculture, Botany, Rural Architecture, &c., lately published, with some Account of those considered the more interesting.*

*TRANSACTIONS of the Pennsylvania Horticultural Society.* 8vo. Philadelphia, 1839 and 1840.

This Society was founded in 1828, and it appears to be one of the most prosperous in America. The list of plants exhibited is not inferior in point of number and variety to those of many of the provincial societies of England, and the culinary vegetables and fruits shown are in greater variety than what usually takes place with us. The number of forced articles exhibited is astonishing, considering that fifteen years ago, as we have been informed, there was not that number of forcing-houses in all the United States. The library of the Society contains 300 volumes; and the Society intends to establish a garden as soon as the funds will admit.

*Book of Fruits; being a descriptive Catalogue of the most valuable Varieties of the Pear, Apple, Peach, Plum, and Cherry, for the New-England Culture.* By Robert Manning. To which are added the Gooseberry, Currant, Raspberry, Strawberry, and the Grape; with Modes of Culture; also Hardy Ornamental Trees and Shrubs. With plates. First Series for 1838. 12mo, pp. 120. Salem, 1838.

The Pomological Garden at Salem, we are informed by Mr. Manning, contains 1500 varieties of hardy fruit trees, and additions are made to it every year from the best fruits of America and Europe. No scions are given out until the fruit is proved, and till a reference can be given to some authority by whom, or in which, it is described. Among the directions for planting we find spring is preferred to autumn, and that "trees should rarely be placed deeper in the ground than they originally stood in the nursery." A very useful hint to an American planter, as would appear from Mr. Bridgeman's remarks on this subject, quoted in our preceding volume.

*Catalogue of Ferns, after the Arrangement of C. Sprengel, with Additions from C. B. Presl, and References to the Authors by whom the Species are described: to which is added a Synoptical Table of C. B. Presl's Arrangement of Genera.* By J. Riley. 8vo, pp. 29. London, 1841.

Mr. Riley is an enthusiastic cultivator of ferns, and he has here produced



one of the most comprehensive catalogues of that order of plants which has hitherto been published in this country. "The arrangement of Sprengel, in his edition of the *Systema Vegetabilium* of Linnæus, 1827, has been followed in this catalogue, rather than the modern one of Presl, because the latter has not yet concluded his arrangement: and the names of species under Sprengel's genera are at present more generally used in collections, and more likely to facilitate correspondence.

"A table of Presl's genera, showing the relation between them and the genera of other authors, is added, and will be eminently useful in the classification of species."

*Observations sur quelques Plantes Critiques des Environs de Paris.* Par Ernest Cosson et Ernest Germain.

The object of this pamphlet is to make known *Carex Mairii* as indigenous to the environs of Paris; for which purpose an analysis of the species, amounting to upwards of fifty, indigenous in the neighbourhood of Paris is given.

*Notice sur le Parolinia, nouveau Genre de la Famille des Crucifères, et sur des Espèces à ajouter à la Flore des Canaries.* Par P. B. Webb. Extracted from the "Annales des Sciences Naturelles."

*Parolinia ornata* is a suffruticose erect plant with linear, entire cinereous leaves and light rose-coloured flowers; a native of the Canadas, and most probably half-hardy in British gardens, to which we trust it will soon be introduced by Mr. Webb.

*Carter's Catalogue for 1841, of a choice Collection of Floricultural, Vegetable, and Agricultural Seeds, comprising upwards of 1900 Species and Varieties of Flower Seeds; and among others some splendid Assortments of German Asters, Stocks, Zinnias, Hollyhocks, &c. Besides a numerous List of other established Favourites, and many new and rare Seeds, well worthy the Attention of Florists and Amateurs in general.* Sold by James Carter, Seedsman and Florist, Holborn, London. Small 8vo, pp. 31. 1841. Gratis to purchasers of Seeds or Bulbs; 6d. each, or 5s. per doz. for circulation.

One of the neatest, most methodical, correctly spelt and accentuated seedsmen's catalogues that have ever been published. The number of fine flowers enumerated, described, and characterised by abbreviations, is quite astonishing; and not only their scientific names are given, but literal translations of them, which is much more instructive, and much better calculated for fixing the name on the memory, than the ordinary practice of adopting an English name, which is sometimes a translation, and sometimes a synonyme. This catalogue, as we think, will not only spread a taste for fine flowers, but will enable the young gardener and the amateur to pronounce and spell their names correctly.

*The Seventh Annual Report of the Royal Cornwall Polytechnic Society.* 8vo, pp. 137, 4 engravings. Falmouth, 1839.

We noticed the Sixth Report of the proceedings of this Society in a former volume, and quoted from it. In that now before us there are a number of very interesting articles, particularly one on the atmosphere of the Cornish mines, but, as it is not of a nature to be directly useful to gardeners, we must pass it over.

*A Dictionary of Science, Literature, and Art, comprising the History, Description, and scientific Principles of every Branch of Human Knowledge; with the Derivation and Definition of all the Terms in general Use.* Illustrated by engravings on wood. Edited by W. T. Braide, F.R.S.L. & E. 8vo. London, 1841. Part I. Price 5s.

To those who cannot afford to purchase a scientific encyclopædia, this 1841. — III. 3d Ser.

promises to be the best substitute that has yet appeared. The articles are evidently written with care and a knowledge of the subject; and, where necessary, they are illustrated by woodcuts. It is very copious in architecture, an art which is every day becoming more popular.

## MISCELLANEOUS INTELLIGENCE.

### ART. I. *General Notices.*

*PRESERVATION and Staining of Wood.* — At the Academy of Sciences, Paris, at the sitting of Nov. 30. 1840, M. Dumas, in the name of a commission composed of Messrs. Arago, de Mirbel, Poncelet, Gambey, Audouin, Boussingault, and himself, made a report on a memoir by M. Boucherie. Though we have given rather a minute analysis of this work, we think we ought, considering its great importance, to repeat the facts already spoken of, in the very words of the commission.

M. Boucherie has endeavoured to render wood much more durable, to preserve its elasticity, to prevent the variations in bulk which it undergoes from drought and moisture, to diminish its combustibility, to increase its tenacity and its hardness, and, lastly, to give it various durable colours, and even smells. To say that these endeavours have been fulfilled by new and simple methods by no means expensive, and by the aid of common substances at a very low cost, is sufficient to characterise the importance of the author's labours.

To imbue an entire tree with conservative, colouring, or other substances, the author has recourse to no complicated or expensive mechanical means; he takes advantage of all the absorbing force (force aspiratrice) of the vegetable itself, and that is sufficient to transport from the base of the trunk to the leaves all the liquids that are intended to be introduced, provided they are kept within certain limits of concentration. Thus, if a tree in full sap is cut at the base, and plunged in a tub containing the liquor it is meant to absorb, it will ascend in a few days to the highest leaves; all the vegetable tissue will be imbued, except the heart of the tree, which, from its hard nature, particularly in old stems, always resists penetration. It is not even necessary that the tree should have all its branches and all its leaves; a few reserved at top are sufficient for the purpose.

It is not necessary to have the tree standing, which would often render the operation impracticable; it may be cut down after having all the useless branches lopped off, and its base then put in contact with the liquid to be absorbed, which penetrates, as usual, into all the parts. Indeed it is not even necessary to cut down the tree; for a cavity made in the trunk, or the greater part of the surface divided with a saw, is sufficient, by putting these parts in contact with the liquid, to cause a rapid and complete absorption of it.

If M. Boucherie has resolved the grand problem he proposed in a simple and practical manner, he has shown no less sagacity in the choice of the substances he has adopted to answer the purposes mentioned above. When the durability and hardness of wood are to be increased, and dry rot or moist decay avoided, he introduces into the tissue pyrolignite of rough iron (fer brut). This substance is well chosen; for crude (brut) pyroligneous acid is produced in all forests by the making of charcoal: it is easy to transform this into pyrolignite of iron, by putting it in contact, when cold, even with old iron, and the liquid thus prepared contains much creosote; a substance which, independent of the salt of iron itself, has the property of hardening wood, and of preventing rottenness, as well as the ravages of insects, in timber used for building. Authenticated experiments made in the cellars of Bordeaux, on hoops prepared by the author, have yielded the most

irrefragable proofs of the great durability of the wood prepared by his plan. Ordinary hoops were reduced to powder at the least effort, while his were as solid as at the first.

When the warping of timber (*jeu des bois*), preserving its elasticity, and rendering it less combustible, are considered, the author finds a cheap preventive in the use of earthy chlorides (*chlorures terreux*). Impressed with the idea that his plans are soon to come into universal operation, he has not been satisfied with merely using chloride of calcium (*chlorure de calcium*) which costs so little, but has tried the efficacious water of the salt marshes which costs nothing, and found it to contain all the requisite qualities. Timber prepared by these saline solutions preserves its flexibility after several years' exposure to the air; when cut into thin slices (*feuilles*), they may be twisted spirally, and retwisted in a contrary direction, without cracking. When exposed to the air, it never either warps or splits, however dry it may be; and it does not burn, or at least with so much difficulty that it is incapable of extending the ravages of a fire.

To these great and useful properties, which will be appreciated and applied in the navy and in civil and domestic buildings, the author has added other applications, which, without having the same utility, hold out new materials and means for the arts. He colours timber with shades so various and so curiously marked, that the commonest woods may be used with much effect for inlaying. The pyrolignite of iron only gives a brown tint, which harmonises well with the natural colour of the parts of the wood which are too close for the pyrolignite to penetrate.

By introducing a tanning matter after the pyrolignite, ink is produced in the body of the wood, and it is thus tinted either blue or grey.

By making the wood absorb pyrolignite of iron, and then prussiate of potashes, Prussian blue is produced.

By introducing successively acetate of lead and chromate of potashes, yellow chromate of lead is formed.

By introducing into the same trunk pyrolignite of iron, prussiate, acetate of lead, and chromate of potashes, shades of blue, green, yellow, and brown are produced, which have the most varied effects. These compositions, capable of causing so many different colours, may be varied *ad infinitum*: their application depends on the taste of the operator. Chemistry is sufficiently rich in reactions of this kind to satisfy the most extravagant wants and caprices.

It is evident on merely mentioning these results, that they have not, and could not have, been found out by chance. The author has drawn them from simple ideas which he had formed of all these phenomena, and these ideas were the results of long, laborious, and close study of the question. The author shows in his memoir the series of labour and reflection which must necessarily have passed through his mind, before arriving at consequences which he has reduced to practice, in itself as simple as it is economical. The ideas and opinions which he sets forth have appeared to the commission to be suitably supported by facts previously known, and by those which he has made public.

An official of the Office of Waters and Forests, M. Millet d'Aubenton, having made many applications relative to M. Boucherie's proceedings to the Academy, the commission necessarily examined the subject with the greatest care: they declare unanimously that, in their opinion, the pieces sent by M. Millet leave the entire property of the discovery, as far as it is scientifically important and useful in the arts, to M. Boucherie. The idea of impregnating large trees and colouring them with different liquids applied successively, is secured to M. Boucherie by patents considerably anterior to all the pieces produced by M. Millet.

In considering the extent of M. Boucherie's labours, the expensive and interesting experiments to which he has devoted himself, the important results he has already obtained, and those which may be hoped for the future, the commission have not merely been satisfied in proposing those measures to the

Academy which are sufficient when the interest of science alone is in question. They have thought that in a matter of public interest, in which our marine, our public works, and our arts are so highly interested, in which our agriculture will find new interest in the restoration of those forests so unfortunately destroyed in some parts of France, something more was necessary than a mere mark of approbation. They propose to the Academy, therefore, to decide :—

“ 1st. That M. Boucherie’s memoir should be placed in the collection of works by foreign *savans*, which it well deserves.

“ 2dly. That a copy of this report be transmitted to the Ministers of Agriculture and Commerce, of Public Works, and of the Marine, Finances, and War.”

The resolutions of this report were adopted. (*Le Temps*, Dec. 3. Communicated by *G. G.*, Dec. 10. 1840.)

*On a Method of Prognosticating the probable Mean Temperature of the several Winter Months from that of corresponding Months in the preceding Summer.*— A paper was read on this subject by Mr. Graham Hutchinson, at the meeting of the British Association at Glasgow. “ From the slowness with which the increased temperature of summer penetrates the surface of the ground, Mr. Hutchinson thought it probable that the last portion absorbed during the summer half of the year, and which descends to the least depth below the surface, should be the first portion given off during the winter half; and, in like manner, that the first portion absorbed during the summer half, and which must descend to a greater depth below the surface than any other portion, should be the last to be given off during the winter half. And though the diffusive tendency of caloric, and the variations of temperature arising from alterations in the direction of the wind, &c., may render it impossible to predict within a week when the first, the last, or any other portion of the summer’s heat is absorbed or given off by the earth’s surface, still, by embracing a period of longer duration, such as a month, we may, on an average of years, come somewhat near the truth. Agreeably to the principle above stated, the months in which an absorption of heat takes place should have corresponding months of retrocession, or some approximation thereto; and, consequently, the mean atmospheric temperature of any month in the summer half of the year would afford a means of prognosticating the mean temperature of its corresponding month in the winter half of the year, so far at least as that mean atmospheric temperature depended upon the retrocession of heat absorbed during the previous summer half. For facility of comparison, the two equinoctial months, September and March, were left out of consideration. The corresponding months of temperature, then, are as follows :—

|            |                   |   |
|------------|-------------------|---|
| August has | October following | } for its corresponding month of temperature. |
| June       | December          |   |
| May        | January           |   |
| April      | February          |   |

“ If, for example, August be warmer than average, the mean atmospheric temperature of October following should likewise be warmer than average. From tables then referred to, Mr. Hutchinson said it appeared that, in Scotland, deviations in the mean temperature of the summer months have a visible influence in producing like deviations of temperature in their corresponding months in the subsequent winter half of the year. It appeared, also, that, in the generality of years, the other disturbing causes, which diversify the temperature of the same winter months in different years, such as variations in the direction and force of the winds, &c., have less influence when averaged for a month than we should be apt *à priori* to suppose. And when the same months, for a number of years, are grouped together and compared, as was done in the tables, the disturbing causes, which may occasion a great deviation from the mean temperature in any particular month in one year, seem partially to neutralise each other, and render the influence of unusual warmth or

unusual coldness in any summer month, in producing a similar degree of unusual warmth or coldness in its corresponding winter month, more apparent than could have been anticipated." (*Athenæum*.)

Some interesting remarks in accordance with this paper will be found in Pouilliet's *Essay on Terrestrial Heat*. — *Cond.*

*Respiration of Plants.* — M. Colin has read before the Academy of Sciences a memoir on the respiration of plants, the experiments detailed in which were performed with M. Edwards, sen.

Scarcely any of the phenomena of the respiration of plants have been hitherto recognised, except the disengagement of carbonic acid gas; and this has been explained by the combination of the oxygen of the air with the carbon of the grain. Thus, according to this theory, the grain is only acted upon by the atmosphere, and the action of water on the respiration of plants is not considered. In the respiration of leaves, carbonic acid is evolved during the night, and during the day it is absorbed, and oxygen is disengaged by the direct solar rays; and these facts are explained on the supposition that the carbonic acid absorbed is decomposed by the plant, its carbon appropriated, and the oxygen disengaged. But this explanation supposes the plant to possess a decomposing power, which to MM. Edwards and Colin it seems difficult to admit; and they have in consequence resumed the examination of this function of plants.

Hitherto the experiments performed on the respiration of grain have always been performed in the air; or when they have been performed in water, the explanation of the phenomena have been limited by what occurs in the air: what has been disengaged in the fluid has not been examined; but this has been done by MM. Edwards and Colin.

They took a globe with a straight neck, the capacity of which was from three to four litres of water (about 183 to 244 cubic inches), with which it was filled; and they then introduced forty large and perfect Windsor beans (*fèves de marais*). To the globe a bent tube was adapted, and which terminated in a jar also filled with water. The beans were then in contact only with the water and the air which it contained, and which could not be renewed on account of the mode in which the experiment was performed; and this is an important circumstance, and upon which the success of the experiment depends.

The first phenomenon which appeared was the disengagement of bubbles of air arising from the seeds: at the end of twenty-four hours the disengagement was considerable. At the expiration of four days the beans were weighed; they had increased twenty per cent in weight. When put into the ground, they came up perfectly; which proves that they had suffered no change. As to the production of gas, that which was disengaged, after passing through the water and received in the tube and jar, was only a sign of the function; it could be only that portion which the water did not dissolve as it was gradually formed, it was therefore smaller in quantity than that which was dissolved. The quantity of air which had passed through the water without being dissolved amounted to from twenty to forty millimetres (1.22 to 2.44 cubic inches); but that which was dissolved in the water, and which was expelled from it by ebullition, was very considerable. Before this experiment, the water in the globe contained about 4.577 cubic inches of air; and after the experiment more than 30.5 cubic inches of gas were expelled. Thus the action of the beans alone produced nearly 30 cubic inches of gas. No doubt, therefore, can exist as to the action of water in the respiration of the beans.

It was found that the gas generated consisted of, 1st, an enormous quantity of carbonic acid; 2dly, an almost infinitely small portion of oxygen; and, 3dly, a very small quantity of a gas which appeared to be azote, or at any rate the authors at present so consider it: its proportion was rather smaller than that of the air contained in the water.

These experiments, then, prove that during the respiration of plants water is decomposed, and that the carbonic acid formed is derived from the oxygen of

the water, which unites with the carbon of the grain. MM. Edwards and Colin propose to examine, on a future occasion, whether the carbonic acid thus formed is totally or partially disengaged, and whether the hydrogen of the water is absorbed by the grain. (*L'Institute*, No. 257., as quoted in *Phil. Mag.* vol. xiv. p. 74.)

---



---

ART. II. *Foreign Notices.*

ITALY.

*MONZA*, Jan. 9. 1841.—In one of my former letters, I think about two or three years back, I mentioned that at Milan, in the garden of Count Castiglioni, President of the Royal Institute of Sciences and Arts in the kingdom of Lombardy, there was a *Salisbùria adiantifolia* female, which had flowered, but which at that time had not fruited. I mentioned also, I think, that it was grafted on a branch of a large male plant of the same species. Well, for the last two years it has borne fruit, and perfect fruit too; as last year I sowed some, and all have grown. They are ripe at the beginning of October, some were eaten and found tolerably good; I, however, have never tried them, and therefore cannot say any thing of their flavour. If I knew how to send you seeds, I would transmit them; if you would like to have some, let me know how to send them, it being rather difficult here to find an opportunity of sending to London.

The Baron Zanoli, already frequently brought under your notice for his rich collection of plants, has this year introduced the following species: *Làrix commùnis pëndula* Godsállì; *Pìnuş japónica*, *P. Russeliàna*, *P. Devoniàna*, *P. pityùsa*, *P. palùstris excélsa*, *P. leiophýlla*, *P. macrophýlla*, *P. oocárpa*, *P. Montezùmæ*, *P. apulcénsis*, *P. Hartwègii*, *P. Pseùdo-Stròbus*; *A'bies gigantèa*, *A. balsàmea* male, *A. balsàmea* female, and a *Dámbara austràlis* 4 ft. high. While speaking of the pinetum of Baron Zanoli, I will give you some notices on the *A'bies monocáulon* (see vol. xvi. p. 99. of the *Gard. Mag.*), which appears to me rather to belong to *Picea*. It was discovered in 1838, in the mountains round Vicenza, in the Venetian States, by M. Giuseppe de Salvi of Vicenza. He only found about ten plants in one locality, but he hopes to meet with others, and parent plants. He told me that all the plants he found were not higher than 3 or 4 feet; that most of them had only one stem, few had two. He is of opinion that the bifurcation was caused by the cattle, which are pastured here during summer, cropping off the original stem.

I have been at work now for several years compiling a catalogue of the plants in the Royal Gardens. Your excellent works, the *Encyclopædia of Plants*, *Hortus Britannicus*, and the *Arboretum et Fruticetum*, are of great assistance to me in this undertaking. I have arranged it alphabetically, and by the side of every genus I have given the class and order according to the system of Linnæus, and the natural order to which it belongs: and as in the present state of science it is of consequence to take the synonymes into consideration, in order not to run the risk, in selecting plants or seeds from different catalogues, of getting duplicates, that is, of choosing a species which we already possess, because they do not all follow the same authority, I have thought it best to introduce all the Latin synonymes, and even most of the Italian ones. As to the rest, that is, the signs indicating the habit, the duration, &c., I have made use of the table you gave in your two valuable works, the *Encyclopædia* and the *Hortus Britannicus*, which in so few columns contains so much that is interesting in theory and practice.

The love of horticulture is making rapid progress in Lombardy, of which we have a proof in the numerous nurseries every year established. In Milan alone, during the last year, two or three have been opened. I will give you soon an account of the new plants which in the course of last year, 1840, have been introduced into the Milanese.

In looking over your magnificent work the *Arboretum*, which is my *vade mecum*, as it ought to be that of every gardener and amateur, containing as it does all that is known of the science, I do not find among the uses made of the fruit of the whortleberry (*Vaccinium Myrtillus*), that to which it is applied in the mountains of the Lago Maggiore (Verbano). In those years when grapes are scarce, the mountaineers make wine for their own use of these berries. They gather them and put them to ferment as grapes are treated, in vessels, adding water in the proportion of three fourths of a Milanese boccale (about 4 pints) to every pound weight of fruit. I have been assured by persons every way worthy of credit, who used it, that it is an excellent beverage, not inferior to the common drinking wine of the country; and that wine made solely of the fruit, that is entirely without water, cannot be distinguished from our best wine. In one year, in three communes, more than 100 Milanese brente (about 960 gallons) were made of it.

The celebrated Dr. Roberto de Visiani, Professor of Botany in the University of Padua, who intends publishing the flora of Dalmatia, in his *Semina H. Patavini Anno 1840 collecta*, gives a new species of *Cytisus*, which he dedicates to the discoverer, Professor Alschinger. Here is the description as given by Visiani : —

“ *Cytisus Alschingeri Vis.*

“ *C. fruticosus*, adpresse canescens, petiolis canaliculatis, foliis oblongis utrinque attenuatis, ramis racemisq. patulis rigidis, calycibus profunde labiatis, labio inferiore ovato-lanceolato subintegro longiore, leguminibus margine incrassatis.

“ *Habit.* In sylvaticis mont. Vellebith in Dalmatia, ubi detexit et sub nomine *Cyt. Laburni* communicavit egreg. Prof. Alschinger. Modo colitur in Horto Patavino.

“ Admodum affinis *Cyt. Laburno*, qui differt petiolis planis, calycibus leviter labiatis, labiis subæqualibus, inferiore ovato apice tridentato, et præcipue ramis racemisq. gracilibus pendulis.”

“ Shrubby, appressedly canescent, petioles channelled, leaflets oblong tapering on both sides, branches and racemes spreading rigid, calyx deeply lipped, lower lip ovate-lanceolate subentire longer, pod thickened at the margin.

“ Found in woods on Mount Vellebith in Dalmatia, by Prof. Alschinger, and communicated by him as *Cyt. Laburnum*. Now in the Padua Garden.

“ Closely related to *C. Laburnum*, which differs in having smooth petioles, and a slightly lipped calyx, with subequal lips, the lower terminating in an ovate three-toothed apex; and especially in having slender pendulous branches and racemes.”

The same professor gives an account, in the above catalogue of seeds, of three other new plants, of which I will speak in my next, as well as of many other things. In the meantime I hope you will make the following corrections to some errors in the *Gard. Mag.*, vol. xvi.

In p. 305. line 17., for “ Milanese pestichi,” read “ Milanese pertiche.” 308. lines 9. and 41., instead of “ Lomani,” read “ Lomeni.” 309. line 20., instead of “ Abate Swagani,” read “ Abate Longoni.”—*Giuseppe Mannetti*.

### ART. III. Domestic Notices.

#### IRELAND.

*PNUS pumilio*.—The tree which afforded the specimens I now send you has been about forty-two years planted, and is now 18 ft. high, branched from the base, and forming a kind of pyramid, with rather a light and elegant appearance, different from any of our other pines. During the tremendous hurricane which occurred here in January, 1839, this tree was completely

uprooted, but fortunately a large ball of earth adhered to the roots, which encouraged me to have it replanted, though I then deemed the experiment hopeless: it however turned out otherwise, and the tree has since grown luxuriantly, and produced the cones now enclosed.

Near this there is another very similar tree, *Pinus alopecuróidea* of the Garden Catalogue, and probably *P. Tæ'da alopecuróidea Hort. Kew.*, which you quote doubtfully in *Arboret. Brit.* as a synonyme of *P. serótina Michaux.* I can find no characters permanently distinct in our plants, farther than the one which we call *P. alopecuróidea* growing more upright, and producing the leaves in larger bundles at the ends of the branches. The cones are similar in both.

Connected with this subject, I may notice that the Earl of Kenmare is now preparing to plant a pinetum at Killarney, on an extensive scale, which may be looked forward to with considerable interest, as that locality possesses a greater combination of circumstances favourable to the growth of American and Himalayan Coníferæ, than perhaps any other place in the whole range of the British Islands. While on a botanical tour to the South-west of Ireland last autumn, I was much gratified to find that *Pinus australis Arb. Brit.* had stood at Killarney without the least protection during the last eight years, and is now a splendid plant 10 ft. high, growing luxuriantly; and at Kenmare, in Dr. Taylor the celebrated cryptogamic botanist's demesne, *Cunninghàmia lanceolàta*, 9 ft. high, and seven years planted. *Rhododéndron arbóreum* flowers there without protection.—*D. Moore. Royal Dublin Society's Botanic Garden, Jan. 8. 1841.*

*The Gigantic Flax.*—I am sorry to inform you that your *Linum altíssimum* has, in our cold and ungenial climate, turned out a failure. It did not reach above  $4\frac{1}{2}$  ft. in height, and has no pretensions to its specific epithet of altissimum. I sent the seeds to my neighbour, Lord Gosford, where they were paid all attention to, but without success. I ought however to state, that the seeds were sown too late, and as they purpose saving the seed, we shall be able to speak more accurately next year. It appears, however, to be so coarse that no fine linen could be made from it.—*W. B. Belfast, Oct. 1840.*

---

#### ART. IV. *The Monument to the Memory of Mr. Douglas.*

I OBSERVE a query on the cover of the February Number of the *Gardener's Magazine*, by W. Godsall of Hereford, respecting the application of the money subscribed for the Douglas Monument, in which I, as secretary, am referred to for a reply. Mr. Godsall and other subscribers have an undoubted right to make such enquiries, and I shall feel obliged if in an early Number you will be kind enough to insert the following as my answer.

After long-continued and repeated trials to obtain an amount of subscription to enable the committee to recommend something like the original plan of purchasing ground whereon to plant some of those trees and shrubs introduced by Douglas, the sum subscribed not much exceeding 170*l.* (a large proportion of which was procured through your exertions), it was resolved last summer to call a general meeting of subscribers, by advertisement in the newspapers, to meet in the George Inn, Perth. That meeting was but thinly attended, Sir P. Murray Thriepand, Bart., of Fingask, in the chair. Several plans were laid before the meeting, and one was decided on. A sub-committee was appointed to see it carried into execution, Col. Murray Belshes, of Invermay, convener. It having been found impracticable to purchase a proper site on any of the neighbouring entailed estates in consequence of the nature of the entails, Col. Murray Belshes put himself in correspondence with the heritors of Scoon, the native parish of Douglas, and requested me to call on the members of the sub-committee to attend a meeting of heritors



in Scoon church, in August last; and, through the influence and the urbanity of the heritors who most readily acquiesced in all his proposals, an excellent and commanding site has been obtained in Scoon churchyard. The foundation has been dug 5 ft. deep and built to the surface; the work is in progress under the inspection of your scientific correspondent, Mr. M'Kenzie, Perth Town, Architect, who kindly gives his services gratis. It is expected that it will be completed early in summer, and when finished I shall transmit to you a drawing thereof, and inscriptions, for which I hope you will find a place in your valuable Magazine.

I feel obliged to Mr. Godsall and yourself, for giving me an opportunity of making this communication, which will, I hope, in the meantime prove satisfactory to the subscribers.—*A. Gorrie. Annat Cottage, Feb. 4. 1841.*

ART. V. *Retrospective Criticism.*

*MR. PENN'S Mode of heating Hothouses.*—Our correspondent N. M. T., in our January Number, p. 42., cautions persons against erecting the apparatus of Mr. Penn, as at first applied by the inventor, and as figured and described in the *Gardener's Magazine* for 1840; because, he says, "persons erecting it exactly according to the sections and descriptions given in the Magazine will find it unsuccessful." He adds that, "as to heating an early forcing-house sufficiently with the pipes placed outside, it would, in particular cases, high winds for instance, amount to an impossibility," &c. We refer our readers to the remainder of the paragraph, which is curious, as having anticipated, by upwards of a month, the objections made to Mr. Penn's plan by Dr. Lindley, in the *Gardener's Chronicle* of Jan. 6. — *Cond.*

ART. VI. *Queries and Answers.*

*WHITE Scale, Brown Scale, Woodlice, Singing-Birds.*—I shall be greatly obliged, if you or any of your correspondents will inform me of the best system of destroying the white scale on pine plants, and the brown scale on peach trees in a house. I am also much troubled with the woodlice on mushroom beds. I have used every means I could devise, but they are of no avail. What is the best and cheapest work containing information suitable for a gardener, on the subject of keeping and breeding canaries and other singing-birds in an aviary in a flower-garden?—*An old Subscriber. Yorkshire, Jan. 18. 1841.*

*The Onion Maggot.*—For several years past my onion beds have been injured to a considerable extent by a small white maggot, which attacked them in great numbers last year, to the almost total destruction of the crop. They commence their ravages whilst the onion is young; and, before there is much bulb, one or more of these devourers attack each root. Last year I sowed my onions in drills upon recently manured ground, which bore the preceding year a crop of potatoes; for a time they looked most promising, but, when they ought to have begun to bulb, it was most mortifying to see the plants, drill after drill, droop; and, when I took hold of the stem, I found that these pests had been at work, and effected a lodgement in the heart of the plant. I have limed the ground without success: last year I gave a good sprinkling of soot over the beds, as soon as I perceived the enemy had begun the attack. I have also sprinkled salt in moderate quantities upon the soil about this period of the year, but without any favourable result. I take the liberty, therefore, of applying to you for advice and information, for which I shall look anxiously to your March Number. What kind of a fly or insect do these larvæ become when they arrive at their perfect state? Do the parent

flies deposit their eggs by preference on any particular kind of manure, or do they deposit them in the garden soil? What means can I adopt to guard my beds of onions against them for the future. — *T. Harper. York, Feb. 6. 1841.*

Our correspondent is referred to our January Number, p. 88., and to Vol. XIII. p. 241. In the latter article he will find the onion fly (*Anthomyia ceparum*) figured in all its different stages, and in the former the only remedy that we have heard of as likely to prove effectual. — *Cond.*

*The small Stag-Beetle.* — The beetle sent by Mr. Thomas Weaver, found by him in considerable numbers in the perfect state, on the 19th of January, in the old root of an elm tree, near Winchester, and which was completely bored through by them, is the small stag-beetle, *Dórcus parallelipédu*s, a very common insect, of which you have given full illustration, both in the *Gardener's Magazine* and *Arboretum Britannicum*. [See fig. 22. from the latter work.] It attacks rotten trees of other kinds besides the elm. On breaking up some of the rotten wood sent, I was pleased to find some of the insects also as larvæ of very small size. — *J. O. Westwood. Hammer-smith, Jan. 20. 1841.*

*Oak Spangles.* — Mr. Long's short note sent to me some time ago on the various kinds of oak spangles, the prevalence of some, and the entire absence of them on certain species of *Quercus*, is so far interesting as confirming to a certain degree, what I have long suspected, that there are several species of gall flies which make these different spangles, the history of which, hitherto neglected, would be an interesting subject of enquiry for an out-door country observer of nature. — *Id.*

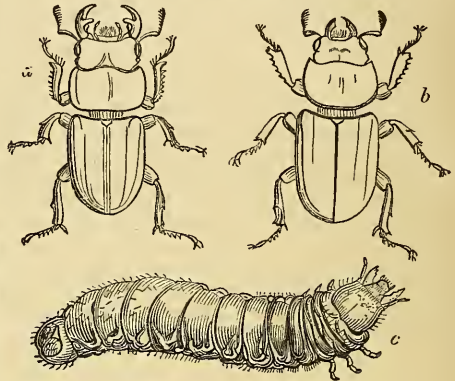

Fig. 22. *Dórcus parallelipédu*s.  
a, The male. b, The female. c, The larva.

## ART. VII. Obituary.

*FRANCIS BAUER, ESQ.* — We have just heard that the remains of this fine-hearted old man were, on Wednesday the 16th [Dec.], consigned to the grave in the churchyard of Kew, in which village he had resided for more than half a century. To the scientific world, his merits are sufficiently known; but the following short sketch of his life, for which we are indebted to a friend, will, no doubt, be acceptable to the general reader.

Mr. Bauer was born at Feldsberg, in Austria, on the 4th of October, 1758, and died at Kew on the 11th of December, 1840. He lost his father (himself an artist) at an early age, and was initiated, with his brothers, in the ready use of the pencil, under the guidance of an excellent mother. He came to England in the year 1788, with the intention to proceed to Paris, where, notwithstanding the progress of the revolution, artists and scientific men were allowed to follow their pursuits without molestation. His brother Ferdinand, scarcely less skilful in the art of delineating botanical subjects, and who subsequently accompanied Mr. Robert Brown as draughtsman on Flinders's voyage, had already been with Sibthorpe in Greece, and was then at Oxford, busy in completing the *Flora Græca*. Sir Joseph Banks soon appreciated Mr. Bauer's rare talents, as well as his singular sagacity in botanical physiology, and prevailed on him to remain in England. Sir Joseph, in fact, settled on him 300*l.* per annum for life, on condition that he should reside at Kew, as

botanical painter to the Royal Gardens, which were then rapidly advancing to a high state of perfection. The munificence of Sir Joseph enabled Mr. Bauer to pursue the bent of his genius, independent of the public and of booksellers; and numberless beautiful illustrations of the rare plants introduced in rapid succession at Kew, by the many travellers and navigators of the reign of George the Third, were the result, works now deposited with Sir Joseph Banks's library at the British Museum, and which all who have examined must acknowledge to be, for accuracy of delineation and colouring, elegance of execution, as well as for physiological and anatomical truth, unexampled at that period. Mr. Bauer was also appointed drawing-master to the Princess Elizabeth: but he was a better philosopher than courtier, and his services, which were given gratuitously, were soon dispensed with. At that time he was occupied on the heath tribe, then in course of introduction, chiefly from the Cape, by Menzies. Engravings were made from these drawings, and Queen Charlotte and the princess used to colour them under his superintendence. The engravings so coloured were afterwards sold by public auction, with other of Her Majesty's effects. Towards the end of the last century, Mr. Bauer commenced his illustrations of orchideous plants, since published by Dr. Lindley. He subsequently turned his attention to the diseases in corn, in which, from his skill in the use of the microscope, he made discoveries of great importance to agriculture, and therefore to mankind; and we may here state, that the only money which he received during his long life, beyond the above-mentioned income, was fifteen guineas, which the editor of one of the cheap publications of the present day sent to him for some short papers on the smut in wheat.

In 1816, the late Sir Everard Home, being engaged in some researches respecting the anatomical structure of the foot of the common house-fly, communicated the difficulties he experienced to Sir Joseph Banks, who immediately introduced him to Mr. Bauer. This led to an intimacy of the most lasting and most useful kind. Mr. Bauer solved every difficulty, and, at the suggestion of Sir Everard, entered on a number of other anatomical enquiries, the results of which were published by Sir Everard in the *Transactions of the Royal Society*. The most remarkable of these were his dissections and drawings of the common red earthworm, the lampreys, conger eel, Mexican Proteus, metamorphosis of the tadpole, generations of oysters and muscles, process of incubation from the egg to the perfect chicken, the eye, structure of brain, nerves, blood, lungs, urethra, and muscular fibre; some of which labours have led to great improvements in the treatment of diseases, and consequent alleviation of human suffering; and all display an unrivalled degree of skill, perseverance, and philosophical acumen, sufficient to have conferred on him the highest fame, had such been his aim. At the suggestion of Sir Everard Home, George the Fourth resolved to establish a botanical museum at Kew, which was to be intrusted to Mr. Bauer. The house now belonging to the King of Hanover was purchased for this purpose; the shelves were prepared, all the botanical books in the king's library were to be removed there, and some had, in fact, been sent down, when, unfortunately, a dispute arose respecting the land, to which the Woods and Forests laid claim; and some artillery waggons driving off with the bookcases gave Mr. Bauer the first intimation that the plan had been abandoned. About this period, Mr. Bauer made his superb drawings of the *Rafflèsia Arnóldii* (the plant of which a model in wax is preserved at the rooms of the Horticultural Society.) He still continued his delineations of Kew plants, and, latterly, more especially of the ferns published by Sir William Hooker. He, at the same time, directed his attention to many microscopical researches, such as the structure of cotton, flax, and wool, the hairs of the various races of men, as well as of many animals, the red snow of Sir John Ross; and, though little known to the public, he had so well established his reputation amongst the select in every walk of science, that rarely, indeed, would any man of science or any traveller of eminence pass through London without visiting him, and no one returned

otherwise than gratified and instructed. Of Mr. Bauer, indeed, it has been truly said, "that nothing prevented his acquiring an extraordinary degree of fame, except his remarkably unobtrusive modesty — he worked rather for the credit of others, than for his own."

Mr. Bauer continued, up to a late period, his microscopic researches and drawings; but, unwilling to risk the chance of leaving any work unfinished, he at last determined to rest, and to attempt no more. Seated near his microscope, which long use had made almost essential to his happiness, he spent his hours in re-examining what his pencil had so admirably perpetuated, and reviewed, in the monuments of his labour, the history of his life. His was, indeed, a life of incessant activity and usefulness. The motives which stimulate common men never influenced him. Vanity, selfishness, and illiberality were wholly foreign to his disposition; and that his innocent labours had spared him from all self-reproach and remorse, his serenity, his cheerful resolve to abide his time in peace, and his final departure from this world under circumstances the most consolatory, full of resignation, faith, and hope, and free from sufferings, save the increasing debilities of old age, sufficiently prove. (*Athenæum*, Dec. 26. 1840.)

*Daniel Ellis, Esq., F.R.S.E., &c.*—It is with much regret that we announce the death of Daniel Ellis, Esq., which happened on Sunday the 17th inst., at his house in Inverleith Row, after an illness of ten days' duration.

To the scientific world, Mr. Ellis has been long very favourably known, as the author of two volumes illustrative of an enquiry into the changes induced on atmospheric air by the germination of seeds, the vegetation of plants, and the respiration of animals; a work which, in tracing some most interesting analogies between the animal and vegetable kingdoms, presents a rare specimen of fidelity in collecting and recording the observations and discoveries of others, and of ingenuity in supplying the deficiencies of their investigations, and in reconciling their apparent contradictions, by original experimental researches and accurate philosophical analysis and induction. He was the author also of the articles on Vegetable Anatomy and Vegetable Physiology in the Supplement to the sixth edition of the *Encyclopædia Britannica*, as well as of other memoirs on topics connected with these subjects, all eminently distinguished by the same spirit of candour, discrimination and scientific genius. [One of these articles appeared in the *Gardener's Magazine*, vol. xv., entitled, "Description of a Plant Case, for growing Plants without fresh Supplies of Water and Air."] ]

Mr. Ellis was born in Gloucestershire. He was educated to the medical profession in London, where he enjoyed, and profited by, the able instructions of Dr. Babington in Medicine, Mr. Cline in Surgery, Dr. Haighton in Physiology, and Mr. (afterwards Sir Astley) Cooper in Anatomy. He subsequently served for some years as a medical and regimental officer in the Essex cavalry; with this regiment he proceeded to Scotland, on the occasion of some disturbances connected with the Scotch militia, and was for some time quartered in the West of Scotland, whence he proceeded with his regiment to Ireland, where he served towards the close of the rebellion. The regiment having been disbanded after its return to England, he shortly afterwards came to reside in Scotland, and about 1801 attended some of the medical lectures in the University of Glasgow, particularly those of Professor Jeffray on Anatomy and Physiology, to which he often afterwards referred with great satisfaction. At Glasgow he took a medical degree, with a view to settling as a physician at Cheltenham. Circumstances having occurred which induced him to give up this intention, Mr. Ellis subsequently came to Edinburgh, in the prosecution of his medical and scientific pursuits; and, having entered the Medical Society, he was in 1806 chosen one of its annual presidents. In that office he was associated with the late Dr. John Gordon, with whom he formed the most intimate friendship. On the premature death of Dr. Gordon, in 1818, his friends looked to Mr. Ellis, who was at the time upon the Continent, as the person best qualified to do justice to the character

and scientific labours of that amiable man and distinguished anatomist and physiologist; and the elegant biographical memoir of Dr. Gordon, published by Mr. Ellis in 1823, sufficiently attests the correctness of this judgment and the warmth of his attachment to his deceased friend. This memoir he inscribed to Dr. Thomson, with whom his intimacy with Dr. Gordon had early made him acquainted, and with whom he ever afterwards continued in habits of the most cordial friendship, founded on mutual respect and regard. Another gentleman with whom Mr. Ellis, at an early period of his residence in Edinburgh, had much intercourse, and whose friendship he highly valued, was the late Dr. John Murray, to whose amiable personal character and eminent talents as a teacher and cultivator of chemical science, he took the opportunity of paying a very elegant and most merited tribute in his memoir of Dr. Gordon. Mr. Alexander Cowan of Valleyfield, and Mr. James Jardine, civil engineer, were also among the earliest of Mr. Ellis's Edinburgh acquaintances, and in their society he ever afterwards took a peculiar pleasure, as recalling many agreeable recollections.

Having resolved on abandoning the medical profession, Mr. Ellis turned his attention to the study of agriculture, and was thus led to the more particular consideration of the economy of the vegetable kingdom, a subject which during the remainder of his life afforded him at once a leading scientific pursuit and an elegant recreation. The interest he took in the formation of the Horticultural Garden was manifest by the selection of his place of residence in its immediate vicinity; and his continued zeal for its improvement is well known to the members of the Horticultural Society, and duly appreciated by them.

Though of an unobtrusive, or, in truth, of a retiring, disposition, Mr. Ellis possessed in an eminent degree the qualities calculated to render his society attractive. His countenance was the index of his kind and joyous heart. His manners were distinguished by gentleness and urbanity, and his conversation was at all times agreeable and instructive, such indeed as might be looked for in a man of extensive and varied scientific acquirements. But the predominant feature in the character of Mr. Ellis was the warm and ever active benevolence of his disposition. No proposal failed to excite a lively interest in his breast that affected the happiness of the human race, that promised to increase its intelligence, or to promote its comfort; whether it came in the humble form of a contrivance for economising the fuel or for improving the fare of the artisan, or in the more dazzling shape of a project for approximating distant regions through the agency of steam-navigation, or for putting a stop to the African slave trade, through the civilising influence of commerce. No one, in truth, was ever more thoroughly under the influence of the principle, that, being a man, he should account nothing alien from him in which mankind is interested. Nor was Mr. Ellis a mere speculative philanthropist. Whatever plan or institution seemed to him calculated to advance philanthropic objects, he was ever ready, liberally, but unostentatiously, to assist in organising and maintaining.

The same dispositions which rendered Mr. Ellis so zealous for the general happiness of mankind, could not fail to lead him to take a warm interest in the welfare of those among whom he lived. Accordingly, to no one more than to him did his friends feel pleasure in communicating any event of an agreeable nature that had occurred to themselves or their companions, assured that their own feelings would meet with a cordial response.

A zealous friend of civil and religious liberty, Mr. Ellis most heartily rejoiced in every triumph which was gained on behalf of these causes at home or abroad. If, at any time, the habitual equanimity of his disposition gave way to an involuntary burst of indignation, it was in speaking of measures detrimental to popular rights, or to freedom of conscience. But, while feeling very intensely, and expressing himself, on every suitable occasion, very decidedly, on political matters, Mr. Ellis's kindness of nature rendered him incapable of harbouring any animosity towards those who differed from him in opinion on these subjects; and, accordingly, though his friendships

lay chiefly among those entertaining opinions on these matters corresponding with his own, he was ready to cooperate with all, in measures of public utility or beneficence.

The qualities which we have thus feebly endeavoured to portray were rendered particularly conspicuous to his friends during the latter years of his life, by the manner in which he supported a long continuance of infirm health and considerable bodily suffering, preserving, throughout, the same cheerfulness and the same interest in public affairs, in the welfare of his friends, and in the progress of scientific knowledge, which had been so prominent features of his character in his days of vigour and health. From the buoyancy of his spirits, the readiness with which he entered into the feelings of the young, and the sanguine views he took of the progress of human improvement, few of his friends, we believe, were aware that Mr. Ellis had, at the time of his death, reached the sixty-ninth year of his age.

During the last twenty years of his life, Mr. Ellis had the good fortune to enjoy the domestic society of two female relatives, whose kindred tastes and dispositions rendered his home a source of enjoyment to himself, and enhanced its attractions to his friends; and whose unwearied attentions most materially contributed to soothe the sufferings to which his ailments subjected him in his latter years. To the feelings which they, and his other attached relatives and friends, must experience on the present occasion, we can offer no more consolatory reflection than that which is so beautifully expressed in the following language of his own:—

“There is a redeeming grace in virtuous sorrow, which lightens the gloom of affliction, and disposes the mind to accept with thankfulness the hopes and consolations which religion and reason supply. And as time removes to a greater distance the events which troubled the soul, we look back upon them with less and less emotion, till at length they become so softened to our view, as no longer to agitate our feelings, but awaken only that hallowed remembrance which sweetly stirs the affections, and purifies and exalts the heart.” (*Scotsman*, Jan. 27. 1841.)

On the 28th of January, 1841, died at Hull, aged 67, *John Cowham Parker*, Esq., an alderman and eminent merchant of that place, chairman of the Dock Company there, and one of Her Majesty's Justices of the Peace for the East Riding of Yorkshire, &c. To Mr. Parker, the Hull Botanic Garden, which was opened in 1812, a few years after that of Liverpool, may be said in great measure to have owed its existence; for, though the idea of such an institution at Hull was suggested to him by Mr. Spence, it was in consequence of Mr. Parker's influence and exertions in obtaining subscribers that the garden was set on foot; and its subsequent prosperity was mainly attributable to the unwearied attention which, in spite of the other urgent calls on his time, he for a long series of years devoted to its financial and scientific interests. No one could well be a more ardent lover of plants, or a more zealous practical horticulturist, than Mr. Parker, or hold forth a more instructive example of how happily these tastes can assimilate with and soothe the cares of a life engaged in weighty public and private duties; and few things could be more exhilarating to one attached to the same pursuits, than to find him, as did his now lamenting old friend who pens these lines, when paying a visit to him at his country house at Hornsea in 1834, as busily engaged in his garden, pruning and planting with his own hands, as if gardening had been the sole occupation of his life.

Whether as a chief founder of the Botanic Garden, an active and most impartial magistrate, or one of the most warmhearted, generous, and friendly of men, the memory of Mr. Parker will be deservedly cherished in Hull, where his loss to the public will not be easily supplied, and to a numerous deeply grieving family, and a widely extended circle of friends, is irreparable.

—*W. S.*

THE  
GARDENER'S MAGAZINE,

APRIL, 1841.

---

ORIGINAL COMMUNICATIONS.

ART. I. *A Gardening Visit to Paris, from June 28. to August 16.*  
1840. By the CONDUCTOR.

WE went to Paris by Brighton, Dieppe, Rouen, and St. Germain, and returned by St. Germain, Rouen, Havre, and Southampton. The health of one of our party being the principal object of pursuit, we did not see so many gardens or other objects as in former years, during the same space of time. We took scarcely any notes, but our impressions were not the less vivid; and we shall give, first, the general results of those impressions, and, next, what may be called our personal narrative.

We first saw Paris in July and August, 1815, remaining there, at that time, above a month, and seeing every thing that was then to be seen by a stranger. We subsequently passed some time in Paris in the spring and autumn of 1819, on our way to, and return from, Switzerland and Italy; and again, as appears in a former volume of this Magazine, in the autumn and winter of 1828-29. We are thus enabled to speak of the general progress of improvement in Paris during the last twenty-five years, and it affords us the very greatest pleasure to state that it has been far beyond our most sanguine expectations. Since 1828, indeed, the improvement in almost every thing that meets the eyes of a stranger is quite astonishing; and a person who carries in his mind Paris as it was previously to 1830, can scarcely form an idea of what it actually is in 1840. The fundamental cause of all this improvement is intercommunication, which, as Dr. Channing has said of cooperation, may be considered as one of the characteristic features of the present day, and, in a certain sense indeed, a result of cooperation. The intercommunication of authors and artists at home in consequence of the formation of clubs and societies, and their assemblage at conversaciones, has rubbed off those asperities or peculiarities which formerly used to render them unfit for general society, and rooted out that growling snarlish disposition which led to mutual depreciation and abuse. Formerly every author, every artist, and every naturalist, thought every other

author, artist, and naturalist, who wrote and practised in the same line as himself, to be his rival or his enemy, and considered himself, if not entitled to abuse him, at least to be acting a prudent part in shunning his company. At present, authors, artists, and naturalists, of the same class, associate together for mutual improvement; and those who, in consequence of greater natural genius, superior education, or from being more fortunate, take the lead of the others, are no longer envied or decried by any kind of indulgence of bad feeling, but rather looked on with satisfaction, as doing honour to the profession to which they belong in common.

The same result which has taken place among individuals in Britain, in consequence of intercommunication, is, without doubt, taking place between nations throughout the world, in consequence of commercial intercourse, curiosity, and the propagation of opinions. The result is more striking in France, from the great enmity which formerly subsisted between us, the French being then, as Mr. Fox observed in the House of Commons, "our natural enemy," and partly from her proximity; but principally, we believe, from something in the French character which has always, as far as mind and manners are concerned, kept them at the head of European civilisation. However, be the cause what it may, it is certain that the mass of the people of both nations entertain the most humanised and friendly feelings for each other, and the strongest wish that these feelings should never give way to others less in accordance with human happiness and refinement. One act on the part of France would greatly tend to promote friendly intercourse between the two countries, viz. the establishment of a cheap postage, like that of Britain. How many seeds, grafts, roots, drawings, manuscripts, printed papers, and other objects connected with gardening or general improvement, could we not send to the different persons that we received civilities from while in Paris, that would be of real use to the country! So rapid is the post between London and Paris, that cuttings for striking, or scions for taking buds from, might be wrapped up in oil paper, or coated over with mastic, so as to arrive in a perfectly sound state. The transmission of such cuttings and scions alone, to say nothing of seeds, roots, and papers, would surely be a considerable advantage to both countries. The free transmission of small parcels, by coach, waggon, or steam-boat, is also an object which we think ought to engage the attention of the governments of both countries. There surely can be no reason in the nature of things why a parcel should cost more when transmitted from London to Paris than from London to Dublin; and yet the difference in the charges is so great, that, in the case of sending books to Paris, or receiving them from that city, it



amounts to a prohibition on single articles such as this Magazine, exclusively altogether of duty. We do most sincerely hope that at no distant time the two nations will, as to all matters of mutual intercourse, become as one; and we even hope that the French system of weights and measures, including the centigrade thermometer, and the decimal division of money (shillings being rendered of the same value as francs), will be adopted in this country.

*Paris.* The general appearance of the people has improved in dress, and this is more particularly obvious in the drivers of *fiacres*, and other public *voitures*. The carriages themselves are also much better; and the circumstance of a tariff of charges being fixed up in a conspicuous place within every public carriage, prevents all disputes with the driver. The arrangement among the omnibus companies, by which, for six sous paid to the first omnibus, you can pass from one omnibus to another till you have reached your place of destination, the course necessary for which may have led you half over Paris, is a singular instance of cooperation; and the printed police regulations for omnibuses are perfect in their kind. They are on no account to gallop; to walk in going through markets, very narrow streets, or over bridges; and always to stand still while any passenger gets in till he is comfortably seated, &c. When one gets into a London omnibus, he can never tell what may happen; there is nothing to hinder the driver from racing, or galloping, or crowding the omnibus with more than the fixed number, or from moving off while the passenger is getting out, so that he with difficulty keeps himself from being thrown down. In short, the state of the omnibuses in London, as compared with those in Paris, is utterly disgraceful to our police; and the same may be said of our stage-coaches and cabriolets. In truth, our police is not sufficiently comprehensive; and we cannot help thinking that, if a commission were sent to Paris to examine and report on all the police and municipal regulations of that capital, the result could not fail to afford us many useful ideas for improvement.

*The Spirit of the People* appeared to us as much changed as their general appearance. The great desire of all classes seemed to be to accumulate property. Every person is more or less engaged in some kind of commerce, manufacture, trade, or pursuit. On looking down on Paris from the railroad to Versailles, as many tall chimneys of steam-engines meet the eye as were to be seen twenty years ago in Birmingham or Newcastle. We could hardly believe our eyes when we saw them. If any person had predicted such a thing in 1815, he would have been thought mad. This spirit of industry is admirably fostered by the laws and the government. In the first place, hereditary titles

being abolished, less value is set on that kind of distinction, and by consequence more on the solid advantages of wealth. Next, the officers or servants of government, from the king downwards, are not paid with unreasonably large salaries, and there are very few undeserved pensions. Finally, the king, both as a king and as an individual, is remarkably economical. If there is any London nurseryman or market-gardener who wishes to raise all manner of hothouse productions, and construct hothouses and pits, at the least possible expense, let him go to Versailles, and examine the forcing-houses in the potagerie, or to Fontainebleau, and see M. Souchet's greenhouse. This excellent king wisely spends what he has to spare in improving the national buildings, and in filling them with works of art; and the thousands which other sovereigns would consume in pleasures which the day after leave scarcely a trace behind, he consolidates in monuments which will remain an ornament and benefit to the nation for future ages. The effect of money spent in this manner is incomparably superior to that spent in luxurious display; because it immediately goes into the pockets of a more intellectual and sober class of men, such as artists, masons, carpenters, &c. This personal character of the king appears to us to have had a most beneficial effect upon the people; from the poorest servants, who place their money in the savings banks to an extent which, as noted by the French papers, seems enormous, to the capitalist, who engages in railroads, steamboats, or other branches of speculation or industry.

*The Education of the People*, which was checked or diseased during the reign of priestcraft, is now comparatively free and spreading, and is, with time and freedom of commerce, all that is wanting to render France perhaps the first nation in Europe; because, whatever the British nation may be at present, from its superabundance of capital, whenever the governments of other nations are equally secure as our own, capital will emigrate. To one point in general education, France has not yet arrived; which is, to render it compulsory on parents to send their children to school till they have acquired a sufficient knowledge of reading, writing, and arithmetic. This, however, will be attained in time, when it is better known how well the compulsory law works in Germany. One excellent law exists, which it would be well to introduce without delay into this country, which is, that no young man can commence schoolmaster, no young woman governess, and no lady set up a boarding-school, without a diploma, or certificate of qualification, obtained after proper examination, from a commission constituted on purpose by government.

*The Expression of Opinion* is much more free in France than in England. It is not that there is much difference of opinion between parallel classes of men in the two countries, but that in

France men are not afraid of stating their opinions either in conversation or in books. Here it is necessary to consider what opinions are marketable; and, in the case of an author, for example, what will sell. The real opinions of persons in France, except perhaps in politics, are seldom either disguised on the one hand, or, when expressed, taken any notice of on the other. In short, with a police incomparably more rigid than ours, and even, as it said, with a system of espionage, the expression of thought is much more free in France than in England.

The *Asphalte Pavements* are among the most striking external improvements in Paris, and in fact they are operating a revolution in all the towns in France. The surface is as smooth as that of a board, and it has a soft agreeable feeling to the feet, quite different from that of walking on the smoothest stone, and which we can only compare to walking on a carpet. In some of the very narrowest of the streets there are footpaths of this material with narrow kerb-stones, which, to save room, are projected over the gutter, as in *fig. 23.*;

and in the Place de la Concorde there is a smooth continuous surface of asphalte, without a single seam or inequality, upwards of 50 ft. broad, by 200 or



Fig. 23. Projecting Kerb-stone.

300 feet long. A greater good to France, in the way of cleanliness and comfort, than this asphalte, can hardly be conceived. The only thing against asphalte for garden walks is its dark colour, and in England its expense; but in England it has this advantage, that the climate not being so hot, it may be used for covering roofs. It has been tried for barn floors, and will make most comfortable flooring for cottages both in France and England.

The *Butchers' Shops* of London are generally considered the first in the world, not only for excellent meat, but for cleanliness and order. In 1815 and 1819, those of Paris were bad in both these respects, but they are now, in point of excellence of meat, not far inferior to those of London, and in point of cleanliness and order superior. In short, next to the asphalte, these butchers' shops made on us the strongest impression.

The *Streets* have been widened, and many new ones built; and, with respect to the narrow streets, plans are fixed on by the municipal government, by which, when any house in a narrow street is pulled down, it cannot be built up again exactly in the same place, but must be set back, and have a foot pavement in front. We saw this done in several places, and were informed by an intelligent architect, M. Daly, the Editor of the *Revue Générale d'Architecture et des Travaux Publics*, that arrangements were made for this being done not only in Paris but in every

city in France, without any compensation being made for the ground given by the proprietors of the houses. Here then is a cause in operation, which, in the course of a generation, will render France the most beautiful country of towns and cities in Europe; because, it must be recollected, the elevations of houses on the Continent are not, like ours, liable to be disfigured by coal smoke, and, in consequence of the bright sunshine, the shadow of every architectural member is distinctly marked. One improvement the streets of Paris are susceptible of, and that is gently elevated crossings for foot passengers; and, if our wooden pavement should be found durable, its introduction, more especially in court-yards and in narrow streets, will be an immense improvement, in short, as great with respect to the carriage ways, as the asphalte is with respect to the footways.

*Street Houses* built within the last ten years are much improved in elevation. Without diminishing their magnitude, and those grandiose proportions introduced by Louis XIV., the elevations are enriched by architraves or other facings to the doors and windows, by string courses or bands indicating the different floors, and in many instances even by sculptural ornaments, finishing always at top with a very bold cornice. As an example, we may refer to la Rue de l'Arcade, which is now in great part built; but there are street houses on a much larger scale in other places. We have been informed that the internal arrangement of these houses is greatly improved, and that separate entrances to the principal rooms for servants, servants' stairs, dressing-rooms to bedrooms, and waterclosets, are as common to newly built first-rate houses in Paris as they are to newly built first-rate houses in London.

*The Public Buildings* are in many instances undergoing improvements, of which, not being finished, we cannot very well judge. Perhaps the most perfect public monument is the Magdalen, which is finished externally, and nearly so within. Interiorly it is ill adapted for a church, and there is no place where a bell tower can be placed without destroying the effect of the edifice. We trust, therefore, that it will ultimately become a depository of statues, or employed for some other analogous national purpose. The Hotel d'Orsay is a quadrangle of apartments for government commissions and councils, which may be compared to our Somerset House, as to magnitude. There is much to admire both externally and internally, and some things also which are obvious faults. For example, in the great central projection, the windows of the front elevation of the principal floor are lofty, with arched heads, but the windows of the two ends are small rectangular openings in two ranges, indicating two stories; so that, when this central projection is viewed at the angle, it presents a manifest absurdity, and we are at a loss to

know whether the room at the angle is of the height indicated by the large windows in front; or whether the upper part of the large windows is false, and there are in reality two rooms one over another, as indicated by the two rows of windows in the end. In the interior, some of the rooms have ceilings which appear to us rather exaggerated in point of ornament, and especially in the depth of the beams. On the whole, however, with the exception of the point alluded to in the exterior elevation, and the introduction of some cornices in it instead of string courses, this building gave us great satisfaction. A square building with an arcade below, with subdued string courses, and a bold projecting cornice at top, on the banks of the Seine, a little further up the river than the Pont d'Austerlitz, and the elevation of a school or college close by St. Sulpice, also pleased us. The attention paid to public manufactories in several parts of Paris and the suburbs was also gratifying; for example, the Gasworks on the road to Passy. The termini of the railroads at Paris, Pecq, and especially at Versailles, are not surpassed by any in England. The waiting-room at Versailles, in the style of Louis XIV., is most agreeably proportioned, and richly and elegantly decorated. The archway of the Barrière de l'Étoile is certainly the grandest monumental building in Paris, next to the Madeleine; and from many parts of the neighbourhood, and especially from the elevated line of the railroad to Versailles, it has a truly magnificent effect. The obelisk of Luxor, 3300 years old, and the fountains put up in the Place de la Concorde, are grand objects. We admire on the pedestal of the obelisk a gilt representation on one side showing the manner in which it was taken down in Egypt, and another representation on the other side showing the manner in which it was raised up in the Place de la Concorde, under the direction of M. Lebas, in October, 1836, in the presence of the king and upwards of 3000 spectators. A copious account of the taking down of this obelisk in Egypt, and of its erection in Paris, will be found in the *Architectural Magazine*, vol. iv. p. 464.; and an elevation and description of a plan for completing the summit of the obelisk, with a bronze cap, in vol. v. p. 560. The bronze cap was put on, and struck by lightning, and the obelisk now remains with a mutilated summit, as indicated in the shaded part of *fig.* 24. The fountains are circular basins, with candelabra in the centre, from which the water falls; and these candelabra are surrounded by immersed figures with their heads above water, from trumpets or other objects held by which water is spouted up into the lower basin of the candelabra. The effect, to our taste, is too turbulent and stormy; we should prefer seeing the water spouted up by the figures only occasionally. A candelabrum

fountain in the centre of the Place de la Bibliothèque appeared to us in better taste, though not so abundantly supplied with water. There are five or six noble fountains now erecting in the Champs Elysées; and, as these and all the others have an unlimited supply of water from the Canal de l'Ourc and the Canal St. Martin, they will form perpetual ornaments of the greatest beauty, and peculiarly refreshing to the sight during the hot weather of the summer months. The Place de la Concorde is surrounded by columns of iron, fluted, bronzed, and gilt, for the purpose of supporting lamps; but these lamps are supported not on the summit of the columns, which common sense would dictate, but on rostra projecting from the columns about half-way up the shaft. The columns therefore support the lamps by accident, or at all events as secondary objects, and not as principals as we think they ought to do. These columns, in short, are much too large in diameter and height for the situation they occupy, and by comparison greatly diminish, in our opinion, the effect of the obelisk, the fountains, and the groups of statues representing the principal cities of France, the Chevaux de Marly, &c., which form ornaments to this very interesting Place.

*The Public Gardens of Paris*, such as those of the Tuileries, the Luxembourg, the Palais Royal, &c., are on the whole better kept up than they were in 1828. The best-kept public garden in Paris appeared to us to be that of the Palais Royal. The beds were richly stocked with flowers regularly placed, each plant forming a large mass, and kept quite distinct, though nearly touching the adjoining plant. The width of the bed admits only of two rows, and there are always two plants of the same kind placed opposite each other. The number of kinds of plants employed is, perhaps, not above a dozen, but they are finely grown, and produce a most brilliant effect. All defects are instantly supplied from the king's garden at Monceau, which, with that of the Palais Royal, is under the direction of M. Schöne, a native of Saxony, a most excellent gardener, and a man of a thoroughly independent character; he reminded us of our worthy friend, Mr. Anderson, of the Chelsea Garden. But a very moderate sum, we understand, is allowed for keeping up these gardens, and this perhaps may account for the meagre state of the borders in those of the Tuileries. The public part of the Garden of the Luxembourg is undergoing great changes

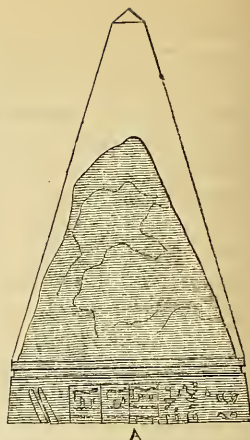

Fig. 24. Summit of the Obelisk of Luxor.

in some parts, and in others it is a mere nursery of roses; but there is a private garden attached to the house of the Duc de Cazes, which is well stocked with flowers and very neatly kept. The whole is under the direction of M. Hardy. The flower-borders at Versailles were rich, but not so much so as those of the Palais Royal, which were only equalled, as far as we could observe, by those at Fontainebleau. The turf, where it is kept watered, or where the soil is naturally somewhat moist, as in the lower part of Versailles, the Trianon, the Palais Royal, and the English garden at Fontainebleau, is close and green; and, were greater care shown in the selection of the grass seeds, and the same attention paid to watering and mowing as at present, the turf of France would equal that of England. Indeed this may be said to be the case in the Palais Royal. We may here observe that in the grounds of M. Vilmorin at Verrières the *Bròmus praténsis*, sown by itself, is found to make an excellent close turf, and to remain of a dark green in the hottest summer months, and on a dry sandy soil. This is a fact of very great value, and it is placed beyond all doubt by several acres of dry sandy soil having been for some years entirely covered by this grass at Barres, where M. Vilmorin raises his seeds. This ought to be a valuable hint to rich proprietors in Australia.

*Villas.* France does not excel in this description of country residences as compared with England, nor will this be the case till her manufacturers and merchants have enriched themselves sufficiently to be able to spare or to sink a part of their capital in matters of taste and luxury. Nevertheless there are a few villas belonging to wealthy citizens, and from these we are enabled to speak of the state of public taste. In general the houses of such villas are plain rectangular masses, displaying scarcely any architectural skill or taste. They are deficient in porticoes, terraces, balconies; and there is a general sameness in the form and size of the windows. There is nothing in the exterior of the building to indicate that one room within is larger or better furnished than another, which ought to be the case if possible in every dwelling-house; and more especially in those built in the country, where the artist is never restrained for want of room. The glaring white of these villas is objectionable in a picturesque point of view, and is even hurtful to the eyes when we are near them; but this, to those who feel it to be a fault, is easily remedied. All the villas in the neighbourhood of Paris are in the same style; as far as we know there is not one which displays any variety of Gothic, or any character, such as castle, abbey, cottage, &c. There are indeed Swiss cottages in the grounds of Baron Rothschild at Surrene, and Baron Delessert at Passy, and one or two English cottages on the road to Seves; but these are chiefly to be considered as ornaments of villas

rather than villas themselves. In the grounds of Parisian villas, as compared with those of villas of the same extent in England, there are too many walks; and in summer every part is too uniformly decorated with flowers in pots, more especially pelargoniums. In general the house is banked up with these pots, on both the entrance and the lawn fronts; and not only are masses of them placed round the trees, round clumps of shrubs, and in the margins of borders and shrubberies, but the parapets of the houses, the piers of boundary walls, and in short every place on the boundary and within it where a flowerpot can be placed, is covered with them. The effect of this, judging from our own feelings, is a sameness which becomes tiresome from its pretence and excitement. In walking through the grounds we find no part which has really the appearance of country, for the continual recurrence of the scarlet of the geraniums, and the petunias or other showy flowers in pots, reminds us of greenhouses, balconies, and the displays of flowers in the shops and *cafés* of Paris. In the distribution of flowers in this manner there can, we should think, be as little satisfaction to the distributor as to the observer; for the former, having no definite object to imitate, can have no limit at which he should stop, and consequently can never feel that his work is complete. The observer, in like manner, seeing that the object is display of quantity, rather than of character, finds nothing either great or touching in the effect produced. He sees an immense number of flowers, which he knows to belong to the greenhouse. A taste for that kind of rural simplicity which is to be found in the grounds of English villas, is of later growth in the human mind than a taste for a profuse display of flowers; but it will follow in due time, and then a great portion of that care which is now given to plants in pots will be transferred to gravel, turf, and trees and shrubs.

*Horticulture* has made obvious progress in the culture of forced articles and stove fruits. Paris is as well supplied as London, during the winter, with asparagus, sea-kale, kidneybeans, potatoes, &c., and better supplied with salads, including blanched succory. Pine-apples and grapes are to be had in the fruit shops every week in the year; the grapes, except for six weeks of March and April, being preserved from the preceding year; but in the royal kitchen-garden at Versailles, and that of Baron Rothschild at Surrene, and some others, grapes are cut fresh from the trees throughout the whole of winter and spring. This is in part owing to the clear atmosphere of Paris during the winter season, which enables them to ripen grapes under glass in the beginning of April, and to the dry atmosphere which admits of grapes ripened in November under glass hanging on the vines till April or later. Pine-apples are abundantly supplied throughout the year, and their culture at Versailles, at Baron



Rothschild's, and at Meudon, is at least equal to the best culture in England. It will, perhaps, surprise some of our readers to learn that in the places mentioned they are grown almost entirely in heath soil, such as is used for Cape heaths in this country. See M. Massy's article on pine culture in p. 17. In some cases this heath soil, which is nearly as dear about Paris as it is about London, is mixed with leaf mould, or mould from hotbed dung; but in no instance, we believe, is loam of any kind added to it.

The following is the course of cultivation at Versailles and Meudon. The crowns and suckers supplied from July to April are put in small pots, and in the course of the months of April or May they are planted in common garden soil on a bed of hot dung, covered with sashes, such as are used during the winter season for growing cabbage lettuce. In the month of October these plants have acquired a large size, and made all the growth necessary for the production of fruit. They are then taken up, disrooted, potted in heath soil, and plunged in bark in pits, where, in the course of the following spring and summer, they produce their fruit. Or in some cases they are planted in a layer of heath soil of about 14 in. in thickness. This layer is placed on boards, and heated from below by fermented dung. In some cases this layer, instead of being placed on boards, is placed on the dung itself, and in that case the plants root into it, are longer of coming into fruit, and produce fruit of a very large size, particularly the New Providence and the Trinidad pines, of which last there are several plants in the royal gardens and at Surrene. Nothing astonished us more than the extraordinary vigour of the fruiting plants in the free soil in pits, the size of the fruit, and the admirable manner in which their pips were swelled. In this situation the plants sometimes remain two or three years, during which time the principal side suckers ripen fruit; and, if many suckers are wanted, the plants after fruiting are cut down within a few inches of the ground, when several suckers are thrown up from the root. The plants are supplied with abundance of water in the growing season, both over the top and at the root, and the glasses are shut close down between 2 and 3 o'clock, after watering, in order to raise steam.

The *Musa Cavendishii* and other dwarf species are cultivated, and produce abundance of fruit; but it is not yet known how far it will come into general demand in the fruit-shops of Paris. It was remarked to us by M. Massy, the director-general of the royal gardens of Versailles, St. Cloud, Meudon, &c., that when the glass of pits and hothouses gets old and apparently somewhat decomposed or deranged in its structure, the plants beneath it cease to thrive, and that the glass of some of the houses at

Versailles, though not broken or cracked, was obliged to be renewed solely on that account.

The earliest grapes are forced in pits or in narrow frames of unpainted boards nailed to stakes, with the joints caulked with moss; and on these sashes are laid, and also made air-tight with moss. Heat is supplied by linings of stable-dung, or by hot-water pipes, or by earthenware tubes of smoke or heated air. Where hot water is employed for heating upon the level system, tubes of earthenware are used instead of metal, which are found to answer perfectly, and to be a very great saving.

*Floriculture.* The passion for dahlias is as great about Paris as it is about London, and we observed that whenever two stranger gardeners met, their dahlias formed the engrossing subject. Proprietors, as well as their gardeners, enter into competition, not excepting the royal dukes. The quantity of showy flowers in pots brought to the flower-markets, and displayed in the windows and on the side-tables of the coffeehouses, far exceeds anything of the kind to be seen in London, partly owing to the greater demand for flowers in Paris, and partly owing to the greater abundance of solar light. No pelargoniums are to be seen grown rapidly to a large size like those of Mr. Cock of Chiswick, or Mr. Green, gardener to Lady Antrobus. Carnations are grown to great perfection by Mon. Tripet Le Blanc in a garden near the Invalids; and the best collection of tulips in France is cultivated by the same highly respectable house. Camellias are grown in large quantities for exportation to America; and the Abbé Berlèze, a distinguished amateur, has a collection of upwards of 600 sorts, which, when we saw them in July, were in excellent health, and very handsome plants. As there is a great demand for plants in pots to decorate rooms in the winter season, heliotropes, lechenaultia, *Phýlica ericoides*, common mignouette, and other plants that flower for a long period together and are not difficult of culture, are trained with single stems and round heads like miniature orange trees, and for these there is a great demand, both in the royal palaces and in the *cafés*, and in the private houses of the more wealthy.

*Arboriculture*, as compared with floriculture and horticulture, is in a great measure stationary; but, in stating this, we must not be understood to include the management of forests. The fuel in universal use in France being wood, forest land is of far greater value, proportionately to corn land or grass land, than it is in Britain; and the management of the forests of the crown being in the hands of scientific men regularly brought up to the profession of forest-surveyors, the art may be considered as undergoing constant improvements. Arboriculture as an art of luxury, by which we mean the introduction of new kinds of hardy trees and shrubs, or the employment of the more rare

and valuable sorts which are already in the country, in the decoration of the grounds of villas, or in the royal parks and pleasure-grounds, seems little attended to. Though there is abundant space at Versailles, St. Cloud, Meudon, Neuilly, and especially at Fontainebleau, nothing has been done in the way of planting an arboretum, which would be a most useful and instructive ornament. The nearest approach to this is a collection in the Bois de Boulogne, which appears to have been recently planted; but it is very deficient in species, and the plants are either not named or numbered at all, or very erroneously named. The soil in the Bois de Boulogne is only fit for the growth of pines, and a national pinetum might there be formed with every prospect of success, as is evident from the growth made by three or four species already there. With a view to forest culture, great exertions have been made in different directions, and by different persons. The late M. Delamarre, author of *Traité Pratique de la Culture des Pins*, and a proprietor in the neighbourhood of Rouen, left his extensive estate and pine plantations to the Society of Agriculture of Paris, a committee of whom direct the continuation of the experiments commenced by M. Delamarre. But, perhaps, the most varied and extensive experiments, with a view to forest culture, made by any individual in France, are those by M. Vilmorin at Barres, of which some account is given in a work entitled *De l'Agriculture des Gâtinais, &c.*, par M. A. Puvis (reviewed in a former Volume). The greater number of kinds of American oaks and of European pines have here been sown in masses upwards of twenty years ago; and, though the soil is poor sand, they have now become handsome trees. At Barres, as in the Bois de Boulogne, in the Hackney Arboretum, and in the grounds of villas in the neighbourhood of London, the most rapid-growing, the straightest and most erect in stem, the most symmetrical in general form, the most graceful in the disposition of its branches, the best adapted for producing timber and for growing on a poor, dry, sandy soil, is the *Quercus palustris*. The next best species is the *Q. coccinea*, which, in point of foliage, may be considered as *Q. palustris* on a larger scale; but the tree is of somewhat slower growth, the trunk not so straight and erect, and the branches less symmetrically and gracefully disposed. *Quercus rubra*, which differs from *Q. coccinea* in having the leaves much less cut, is found, both at Barres and in the Bois de Boulogne, to grow much more rapidly than *Q. sessiliflora*; and though the timber is of little value as such, and would not be worth growing in England, yet in France it is valuable as fuel. It is singular, that neither at Barres nor in the Bois de Boulogne are there any specimens of *Q. álba*; the reason assigned for which is, that the acorns lose their vitality during their passage from

America. The tree, however, thrives well in the climate of Paris, as appears by specimens in M. Vilmorin's grounds at Verrières. *Q. tinctoria Willd.* is next to *Q. rubra* in point of vigorous growth, and is expected to save France several millions sent to America for its bark.

(*To be continued.*)

---

ART. II. *A Substitute for Hand-Glasses, and a more economical Mode of using Glass in Forcing-Houses suggested.* By A. FORSYTH.

I HAVE often felt sorry in passing by some spirited amateur's garden, to see his little lean-to roofed hothouse glazed up to the apex, with two glazed gable ends, and a yard or more of upright glass in front. If this gentleman is rich enough to be possessed of two hothouses, you generally find them in separate compartments of the garden, with glazed doors in the glazed gable ends of each; or, if by any chance they do adjoin, you may rely upon finding them divided by a glazed partition. I wonder these schemers never thought of glazing the back wall to catch the northern lights, not only the aurora borealis, but also "the rays of the bright polar star:" the first is certainly a very fickle and capricious source of light, and far from fervent; and the polar star, though a shining light, is not by any means a burning one, yet makes amends for the feebleness of its beams by the constancy of its services: for, though the sun himself may vary, and the moon change, the polar star will assuredly face the frosty north, like the point of the magnetic needle, day and night, alone and unalterable, amid the mutability of all things sublunary and celestial. However ridiculous this foolery may appear of glazing the dead north wall, it cannot be denied that in the shape of hand-glasses it is practised to the fullest extent in almost every garden in Britain.

Before I enter upon the immediate subject of this paper, allow me to remind the proprietors of such houses as those above described, that they have used as much materials to make one bad hothouse as would with judicious arrangement have made two good ones of the same size: but, as I have already written on this subject (*Gardener's Magazine*, vol. xvi. p. 229.), I need not now repeat what I have said. The actual measurement of a common square hand-glass is seven square feet of glass to light and shelter two and one fourth square feet of ground, being a little more than three times as much as is really necessary; for I think few will dispute that cucumber or cauliflower plants, when they happen to be placed in a common melon frame (the surface of the glass and that of the soil in the frame being nearly

parallel and only a few inches apart) have sufficient light with a square yard of glass roof over every square yard of soil. Contradict this who can. I have already in the *Gardener's Magazine*, vol. xiii. p. 62., shown the suburban gentleman how to economise his culinary and fruit department, and to make two acres produce as much as three acres do now, and of better quality; or in other words by a different arrangement of his crops, and a little expense in trellising over his walks that now produce only weeds and mud, this hitherto uninteresting department of a suburban residence will become not only a profitable, but a grateful and flowery promenade; and, since it adds one third to the produce of his property, as good as gives him another garden half as large as that which he now possesses. I have also shown him how to collect his garden structures in a group, thereby saving much of the space they now occupy, and much labour in attending them, when so widely scattered as they now generally are; and, as one hothouse will help to heat another closely adjoining it, one half of the fuel will serve, if properly applied. Add, also, that much less than half the expense in building materials will erect the group stronger and better than the broken mass is at present in most gardens.

I now offer, with the glass used in the common hand-light above described, to roof more than three times the extent of cucumber, cauliflower, or propagating bed, that that hand-glass now covers, and that too in a far more substantial and less intricate manner, the lights being simply a square or quarry of cast iron of the annexed form (*figs. 25. to 27. p. 207.*); and though the hand-glass can only be used to shelter dwarf crops on a horizontal or slightly inclined plane, yet the quarry lights will not only light and shelter the same squares that hand-glasses are now used for, but are also convertible into a roof adapted to the culture of any exotic usually grown in British gardens, and, like tiles or mosaics, may be used to roof or fill in any right-angled figure, from the fancy awning over the ladies' own pet bed of double early blue and white scented violets, which is, perhaps, as near the earth as glass ever need be placed, up to the lofty ridge and furrow roof which you so much admired at Counsellor Harrison's and elsewhere.

To the market-gardeners around London these quarry lights, instead of hand-glasses or bell-glasses, would effect an immense saving, were it only in the space of ground they take up to stand on when idle, and in the labour they take to carry them by hand from place to place. Hand-glasses are a very fragile and awkward freight, either for cart or waggon; whereas these quarries will ride safely at the rate of fifty in a wheelbarrow, and this fifty will only occupy a cubic space of 25 in. on the side or about 150 in a solid yard. When the season of one crop is

over the market-gardener could convert in one summer day that which yesterday was the roof of his early vinery into a field of hand-glasses for gherkins. This is to be effected by having small frames composed of four sawed boards, tarred (not painted), in the form of a one-light box. (*fig. 25.*) Wood is cheaper and stronger than glass for uprights, not to mention that by this arrangement the market-gardener has three glasses for one; and by having all his glazed structures on this uniform plan he would be enabled to force many small crops from plants in the open ground, such as rhubarb, &c., by placing hot litter between the beds, and something like a tulip awning, but stronger, for the quarries to rest upon after the manner of a span roof over the crowns of the plants. I give this as an example of what might be done with a set of the quarries that could only be spared for thirty or forty days; but a peach-house, for example, is sometimes stripped of its glass to ripen and flavour the fruit: and if the lights are large and clumsy, as they generally are, and calculated to fit between no rafters but their own, they are perhaps stored in the sheds till the forcing season commences again, for a period of time during which they might have protected plants or matured fruit of melons or the like, of as much value as their crop of peaches. But I need say no more to recommend the quarries; for the value must be sufficiently obvious to every one, of a uniform article of durable materials, so perfectly at the command of the proprietor and the practical man, exposing so small a surface requiring paint, and, though firm and permanent in its nature, as portable as a herdsman's tent.

Gentlemen will build plant structures more liberally and with greater confidence when they can rest assured that the great body of the materials used will descend as heirlooms unimpaired to their children's children, though it may have changed places as often and as easily as the cards of a pack, and like them also by various arrangements have played many different games.

Now for their economy. I have known good lights, made of deal and kept well painted, begin to decay after ten years' hard forcing; yet it is but justice to state that I have seen others, under very different circumstances, attain the patriarchal age of four score; but from calculations that I have carefully made from the extensive and beautiful sets of iron lights at Syon, compared with the wooden ones there and at other places, I am convinced that at the end of twenty years iron quarry lights will be found one half cheaper than wood; and whilst the latter would by that time get very tender over hard forcing, if not quite rotten, the iron quarry well glazed and painted would be ready to go down with the rising generation, sound and serviceable for centuries to come; when they will shelter flowers of whose beauty

and fragrance the British botanist knoweth not, and ripen fruits that are as yet strangers in our clime, of whose delicious flavour neither alderman nor mayor has any adequate idea; and, though the shortness of human life and the parsimony of those who hold the reins of gardeners and the sinews of gardening, may hinder me from seeing this heyday in the full tide of its meridian splendour, I know that it is founded in reason, which must ultimately prevail over old customs and caprice. Yet, deprived as I may be of this feast of reason, to see gardening rise so high, and so many of the finest flowers and fruits of every land produced with so little cost in our native earth, and beneath the cloudy cold inhospitable skies of Britain, I must console myself, and conclude with the happy alternative, that, if I am not here on earth to see it and rejoice, I hope to be in heaven, where I shall neither murmur nor repine at the glorious gifts that await posterity in this region of thorns.

*Alton Towers, Shrove Tuesday, 1841.*

Fig. 25. shows a perspective view of the box, with the four notched uprights for holding the sash in its place. Fig. 26., view of the sash, in which may be seen the square pivots at the angles. Fig. 27., end view of the box, showing the uprights at the angles for supporting the sash, either close over the box, or raised to different heights to admit more or less air. By means of the notched uprights, the sash may either be raised 6 in.

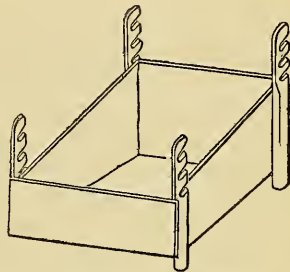

Fig. 25. Hand-Box, as a Substitute for a Hand-Glass.

above the box at top and bottom, or it may be raised 3 in. or 6 in. at the back, and not raised, or raised only 3 in., in front, so as to admit more or less air at pleasure, and yet throw off

the rain; the sash being in any of these cases held firm in its place, so as not to be liable to be disturbed by wind. The pivots which fit into the notches are square, in order to admit of their being mounted on rafters of different kinds, so as to form



Fig. 26. Sash for a Substitute for a Hand-Glass.

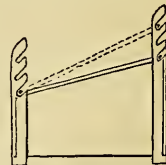

Fig. 27. Side View of Hand-Box.

coverings to frames, pits, or even forcing-houses. Supposing, says Mr. Forsyth, "a bed of violets, running east and west in the 1841. — IV. 3d Ser.

open air, 12 ft. long, and 3 ft. 6 in. wide; drive seven notched pegs, 2 ft. apart, down the centre of the bed, to stand 1 ft. above ground; and seven down each side, at the same distance apart, but only 4 in. out of the ground; then, to make the sides and gable ends, take a piece of turf, 4 ft. by 4 ft., shaped out with the edging-iron, and taken up with the turfing or floating spade, 1½ in. thick, of the proper shape, so that it may be set on edge and kept so by a peg on each side, and having the green side out. When the lights are put on, with every alternate one higher than, and embracing the iron edge of, the two under it, you will have a very elegant little flower-house, which a labourer might erect in an hour with sixpenceworth of building materials, and the finished structure would have thus every other light hinged, and ready to admit air, or allow of watering and gathering flowers, like a complete forcing-house." This box may be used in the open ground for forcing sea-kale, rhubarb, and for a variety of other purposes. We regard it as promising to be one of the most useful and economical inventions that have been introduced in horticulture in our time. — *Cond.*

---

ART. III. *On Mr. Penn's Mode of Warming and Ventilating.*  
By JAMES MAIN, A.L.S., &c.

MR. PENN'S new method of maintaining a constant current of warm air through forcing-houses appears to be a very great improvement, as affecting the health of the plants. Air in motion has always been considered more salubrious to plants as well as animals, than that which is stagnant, whether moist or dry. The ascending growth of trees has ever been attributed to the action of the wind upon their stems and branches, which, by bending them forwards and backwards, gives to the rising sap a kind of pulsation, a diastole and systole, of the membranes producing enlargement. Farmers maintain that turnips grow fastest in windy weather; and I knew of an experiment made on one plant to prove the truth of this idea. A turnip-hoer marked a single plant near the gate of the field in which he was employed, and every time he passed in or out, turned the plant first to the right and next to the left, during about a fortnight he was at work in the field. The plant was evidently assisted by this manipulation, and exceeded in bulk the other plants that grew around it; and which circumstance put an end to the experiment, for a liquorish cow-keeping boy made free with the favourite, before it was the size of a walnut.

My own opinion on this matter is, that the frequent fracture of the fibres on each side, caused the emission of an additional



number of roots, which of course procured additional nourishment to the plant, and hence its larger size. The same may be the case with trees and shrubs, which may have portions of their fibrous roots disturbed by gusts of wind.

The usual expedient for ventilating hot-houses, as it has been called, is rather a misnomer; for, in fact, sliding lights were and are employed more for reducing the temperature than for admitting a current of air through the interior. Indeed, a current of air, whether hot or cold, is ordered by some of our preceptors to be provided against by interposing some kind of open fabric over the openings; and this is really sometimes necessary. But many practical men have long ago felt the inconvenience of stagnant air in forcing-houses, which induced them to try to dissipate it, by always opening both front and top sashes at the same time; or by setting both end doors open at once, in order to produce a clear and strong current through the building. For the same purpose, I have myself used what I called a *flapper*; a thin panel of wood held between the hands, and flapped forcibly downwards along the paths of the house, which dislodged the lowest stagnant air.

Mr. Weeks, senior, of the King's Road, Chelsea, who has done, and is doing, so much in building and heating houses by hot water, and who unites a knowledge of general gardening with very considerable abilities as a mechanic and engineer, has a vinery on his premises in which he invariably produces splendid crops of grapes. Two or three years ago, he noticed that part of his crop suffered from the want of ventilation, and, knowing how rapidly hot air ascends, made, or rather inserted, a row of three-inch pipes in the front wall, the outer ends flush with the face of the wall, with stoppers to be used occasionally. The inner ends of the pipes are brought close to the front hot-water pipe, so that there is a constant blast of cold air impinging upon the hot pipe, and from that to the top of the house, escaping there through sliding shutters, which are shut or opened according to the state of the weather. This arrangement qualified the heat at the bottom of the trellis, and served to increase its ascent to the top; and, at any rate, the vines grew and bore beautifully.

It appears that heated air can be made to descend against its natural tendency, by first withdrawing the colder and heavier air from the lower part of the house: but whether a current of air be impelled upon plants from above or from below can make, I think, but little difference to the health of such as are shrubby; but, for pines plunged or set on a bed, a descending current is most to be preferred, merely for its penetrating so much more freely among the leaves, and reaching every part exposed to the light.

Upon the whole, the endeavour to procure a constant current of air through hothouses is highly commendable; and, as Mr. Penn has succeeded admirably, it is to be hoped that, as he has had the honour of having made a great improvement in garden architecture, his discovery will not to himself be a barren one.

*London, Feb. 18. 1841.*

**ART. IV.** *Notice of a Ladder for thinning Grapes in Hothouses.*  
By JAMES EATON, Gardener, Melbury Park.

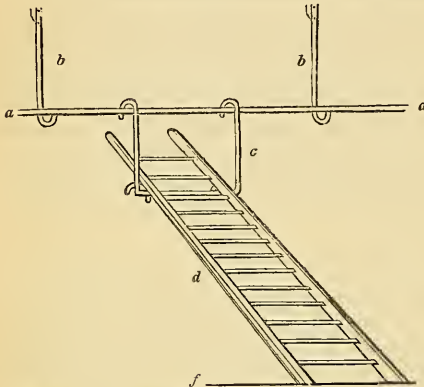

Fig. 28. *Ladder for thinning Grapes.*

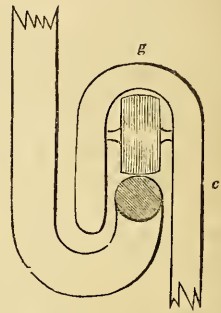

Fig. 29. *Section of the horizontal Rod of the Sliding Ladder.*

In *fig. 28.*, *a a* represents a  $\frac{3}{4}$ -inch iron rod, which reaches from one end of the vinery to the other, suspended about 2 ft. from the rafters by iron rods *b, b*, which rods have turned up ends to support the horizontal rod in the manner shown in the sections, *figs. 29.* and *30.*; *c, c*, irons to hang on the rod to support the ladder, also shown in the section at *c*; *d*, the ladder; *e*, the rafter; *f*, part of the sill of the front wall, on which the lower end of the ladder is supported; *g*, upper part of the crooked irons *c*, showing a small wheel to facilitate the moving of the ladder along the horizontal

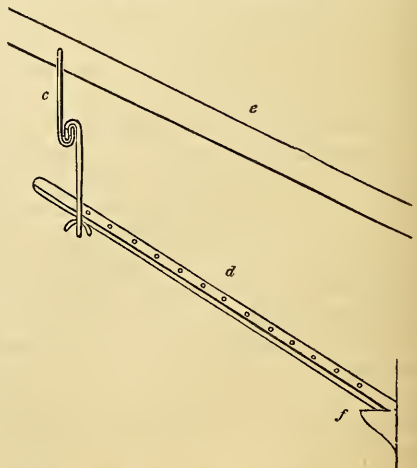

Fig. 30. *Side View of the Sliding Ladder.*

rod. A ladder of this kind is in use in Melbury Gardens, Dorsetshire, for pruning the vines, and thinning the grapes, on a roof trellis, over a stage of greenhouse plants.

ART V. *Description of a Mode of arranging Hempen Lines for supporting Scarlet Runners, Convolvuluses, or other twining Plants.*  
By C. MOBERLEY.

TAKE  $\frac{1}{2}$ -inch thick and 2-inch wide rods or laths, join them at top as in *fig. 31. a*, so as to leave the ends a few inches beyond the junction; stick the lower ends into the ground, just within the lines of the plants. Connect these triangles by similar rods at the bottom, as at *b*, about 3 inches above the soil. Take a cord, fix it firmly to the lower bar; carry it over the upper bar, which is placed in the cross formed by the long ends left, as shown in the figure. Make a loop a yard long, carry the cord again over the plank (that is, round it), and fix the other end to the lower rod on the other side. In like manner go on through the whole length, taking care to make the loops all

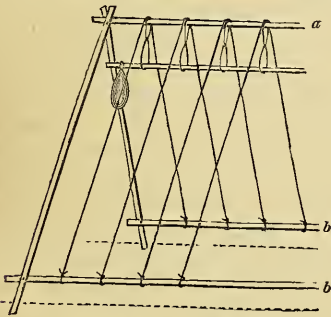

Fig. 31. Prop for climbing Plants.

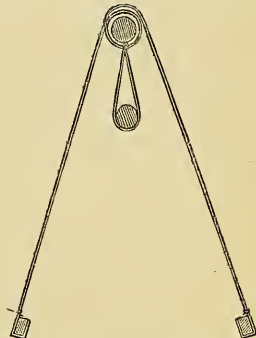

Fig. 32. Section of the Prop for climbing Plants.

of the same length. Through these loops suspend a long rod or bar, the section of which is shown in *fig. 32.*; hang to this bar bags of sand, one of which is shown in *fig. 31.*, as many as may be wanted. Train the plants up the strings, and when they are well grown the whole will be covered, and when in flower the appearance will be very ornamental. By this method, the cords being fixed to the lower bars will not pull the plants out of the earth, the tension and contraction of the cords being counteracted by the bar suspended in the loops, which is raised or lowered by every change of atmospheric moisture; so much so indeed, that, in any garden in the neighbourhood of St. Petersburg, it serves as a hygrometer.

*Petersburg, August, 1840.*

ART. VI. *The Earth-Worm, considered with reference to Horticulture.*  
By G. J.

THE common earth-worm (*Lumbricus terrestris* Lin.) has a long cylindrical contractile body, composed, when full grown, of from 100 to 150 narrow segments or rings, of a dusky red or flesh-colour. It has neither eyes nor tentacula, nor, indeed, any external appendages, and the head is only to be distinguished from the posterior extremity by being narrower and more pointed. About one third of its length from the snout we perceive a sort of belt (clitellum) on the body, embracing from six to nine rings, which are more prominent and fleshy than the others. This belt begins at the thirty-second segment, and indicates the position of the organs required for the reproduction of the species; and, as the worm is hermaphrodite, it follows that every individual should have this belt similarly formed, but age and the influence of the generative action cause it to vary considerably in its degree of distinctness, for it swells out in the season of love and becomes less marked, or even undistinguishable, when this has passed away. Every ring of the body is furnished with eight short spines or bristles, placed in pairs, so that taken together they form four double rows along the sides. These spines are scarcely visible without the aid of a magnifier, and are subservient to locomotion. On the ventral surface of the sixteenth or seventeenth ring there is a pair of pores or fissures raised on small mammiform processes; and there is a similar pair, but so minute as to have been generally overlooked, on the twenty-seventh or twenty-eighth. The former pair are intimately connected with the reproduction of the species, but the function of the latter is uncertain. Besides these pores there is a series of very minute ones along the back, one pore to each ring, except to the anterior ones, which are unprovided with it. They are most easily seen near the middle of the body, and especially on that part of it which intervenes between the sixteenth mammiferous ring and the belt. The series consists altogether of from 110 to 120 pores, and they are believed to be the entrances to the oblong pulmonary vesicles arranged in a series along the sides, and in which the blood of the worm is aerated. Some good naturalists affirm, however, that they are merely mucous cysts for furnishing the slimy fluid which lubricates the surface; and Morren, while he maintains their tracheal character and use, is also inclined to admit that they may be at the same time ducts for the issue of the excretion just mentioned.

The earth-worm has a well developed ganglionated nervous system, but from the non-existence of the proper organs, physiologists have come to perhaps a hasty conclusion that its senses must be limited to those of taste and touch. The latter every thing proves to be exquisite, and is the great regulator of the

animal's habits. When more than half-extended from its hole, and intent only on self-enjoyment, we nevertheless cannot advance within several feet of the worm before it feels the approach of harm, and hurriedly retreats within its burrow. No one is so unobservant as not to have noticed this watchfulness, and I have been sometimes puzzled to explain how the animal was made aware of my approach, although it is usually accounted for by saying that it had felt the slight trepidation of the ground occasioned by my tread. The worm is equally sensible to every influence of the season and of the atmosphere: it feels them all. Hence in winter it burrows deeper and deeper, to a depth of 3 or 4 feet,; as the cold increases, to get beneath the freezing soil; and it reascends with the thaw, so that in the calm of temperate evenings it is ready to venture out to the surface, which worms do very frequently. In spring the earth-worm is seen in hundreds at the surface, every where throwing out its coiled casts, drilling the walks of our gardens and the interstices of the pavements, and trailing its serpentine body from hole to hole with rapid eagerness and energy. This season is most genial, most in harmony with the tone of its nerves; but, when again the summer heat reigns oppressive, the worm seeks the shade and moisture necessary to its existence, by hiding in the earth as it did in winter; and, as the parchedness of the ground increases, it digs down to a moist soil or perishes from siccation. After a long drought, worms seem to me to anticipate a coming change, for I have observed them close to the surface even before the first fall of rain, prepared, as it were, to meet the shower now so welcome to them. But long rains are very hurtful to them; and great numbers are, in such a season, forced from their burrows, and drowned in the little pools which fill every pit and hollow of the garden grounds.

It is to be hoped for the worm's sake that its taste is less acute than its touch; for, destitute of tongue, proboscis, teeth, jaws, or even a suctorial mouth, it is doomed to feed upon the soil in which it burrows, swallowing the earth mixed with all its decaying organised remains, from which its nutriment is extracted. Worms are very fond of drawing into their holes blades of grass, straws, fallen leaves, and such like objects; but this is scarcely for the purpose of food, though shreds of them have been found in the stomach, where are also sometimes found small stones or gravel. The mouth is a small orifice in the first segment, placed in an emargination formed by two lips, of which the upper one is the larger and more projecting. The alimentary canal extends from the mouth to the opposite extremity, where it ends in the vent. The stomach is composed of two pouches, of which the first is membranous, and may be compared to a crop, while the second is muscular, and is analogous to a gizzard.

The earth-worm moves along the surface, or in the soil, by alternate elongations and contractions of a determinate portion of the body. Stretching forward the anterior extremity to the utmost, it is then fixed against the ground by means of the lateral bristles, and now the rest of the body is drawn to the fixed point. It can move backwards or forwards with nearly equal facility; and, when seized in its progress, it wriggles and twists itself into many coiled knots and circles. This it does also when wounded, and its writhings surely indicate a severe degree of suffering in the poor worm, which is too often wantonly trod upon. The movements of the earth-worm in its burrow are performed with much greater rapidity than on the surface, a superiority which results from the disposition of the bristles along the sides, for in a circular tube alone can they all be brought into action and made to act as fulcra, the animal having the power of protruding them to a slight extent. Hence, we find that the hole of the worm is of the same figure as its body, and nearly of the same calibre, that the ascent and descent may be retarded neither by over-straitness, nor by a wideness which would render the contact of the bristles against its walls impossible. The holes are in general sinuous and worked in an oblique direction, and lined with the slimy juice which exudes from the animal. They vary in depth from a few inches to upwards of 4 ft., and have two, or even occasionally several, apertures, of which one is the vent whence they eject those vermicular pellets of earth that have passed through the intestine, and are in fact moulded and fashioned within it.

The mode in which the earth-worm burrows is this. The anterior extremity of the worm forms a cone, gradually tapering from a little in front of the belt to the snout, which is formed by the upper lip being somewhat elongated over the mouth, like a short proboscis. As this can be shortened and thickened, or made gracile and sharp at will, we can understand its fitness as an auger, and its equal aptness for making a hole rather larger than the body when relaxed and undistended. Wishing to burrow, and having selected a soft moist earth, the worm stretches forward this anterior portion of its body and stiffens it. It now pouts out the upper lip, and rendering it, too, tense and elastic, the worm pushes it under the soil or clod, raises it, and casts it aside: then again it digs and loosens another portion of earth until, by many repetitions and much patience, the tunnel is insensibly completed. As the worm swallows the great proportion of the soil raised in the progress of its work, Nature has given it no instruments for the removal of the obstacle, such as have been gifted to many other boring insects.

The reproductive organs of the earth-worm coexist in every individual; but the copulation of two is required to impregnate

the eggs, and fit them for the continuance of the species. Spring is the principal season of their amours, and the act is usually consummated during the stillness of night or in the dewy morn: but no season (if we except the depth of winter) nor hour is forbidden. Whether worms copulate and breed oftener than once in the year is unascertained; and considerable obscurity hangs over some other circumstances in their generation which we need not dwell upon. They are either ovo-viviparous or oviparous, i. e. they do either produce their young already hatched or they lay eggs; but their eggs are so peculiar that doubts have been entertained of their real nature. When digging his garden plot the amateur will now and then turn up, from a considerable depth, a cluster of them, and they deserve to be examined. Those which are laid in early spring are hatched in the months of June and July. When of full size they are as large as a pea, elliptical, with a tubulous aperture at one end and a small point at the opposite pole. The shell, or outer coat, is horny, elastic, smooth, and semitransparent. When immature the egg is roundish and filled with a granular fluid matter, and from this matter an embryo worm is gradually evolved, which, at a late period, the transparency of the shell permits us to see lying coiled up within. This young one (for there is never more than one) escapes at length through the tubulous aperture, when it is rather more than an inch long, and in every respect like its parent, except only that the belt is either unformed or inconspicuous. When, on the contrary, the embryo comes hatched from the parental body, it is only about four lines in length; and four months elapse before it attains the size of that born from the egg. They do not reach their full size until after a year; and their life is probably not extended beyond three or four. In *fig. 33.*, *a* is an egg before the embryo is visible; *b*, the same egg with the embryo coiled up; and *c* the embryo worm in the act of escaping.

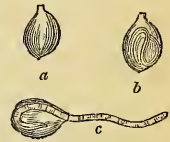

Fig. 33. Eggs of the Earth-Worm.

There is a popular belief that if the earth-worm is cut into no matter how many pieces by the spade, every portion will in time become again a perfect individual. There is much exaggeration in this statement. The worm certainly recovers from wounds and lacerations of such extent and numbers as proves a very remarkable tenacity of life in it, and a very considerable reproductive power; and it does indeed reproduce lopped-away segments readily, provided they have been severed from behind the belt. If the body is divided into two halves, the anterior containing the belt will reproduce a new tail, but from the posterior portion a perfect worm is never evolved, although it continues to live for a month or two, and grows in some degree. If the division

is made into three parts, the middle and hinder ones die after some weeks' struggle for existence, and some efforts at reparation. The mouth and lips are perfectly reproduced, provided the cerebral ganglions have not been included in the section.

[The natural uses of the worm appear to be, to serve as nourishment to moles, hedgehogs, frogs, toads, snakes, lizards, birds, fishes, and some kinds of insects. It is also said by naturalists that worms are useful to plants by penetrating the soil, loosening it, rendering it permeable to air and water, and even adding to the depth of the soil by bringing up its worm-casts to the surface. This last opinion, however, we conceive to be entirely erroneous. Soil is not loosened by boring through it, but rather rendered firmer in the parts not bored through; so far from being rendered permeable by water in consequence of the bores of worms, it is rendered less so, the worm-casts deposited on the orifices of the bores always being water-tight; so much so indeed, that, when lawns where worms abound are to be watered with lime-water in order to destroy these, the first step is to brush away the casts with a long flexible rod, or remove them with a rake, to let the water enter the bores; it having been found from experience, that, when this operation is neglected, the lime-water sinks into the soil without producing much effect. With respect to worms adding to the depth of the soil, an opinion first propagated, we believe, by Mr. Charles Darwin, we consider it to be entirely a delusion, as we have endeavoured to show in Vol. XIV. p. 95.

The injury done by worms in gardens is very considerable. By their casts they disfigure walks and lawns, and, by cutting through the roots, they injure more or less all plants whatever; and particularly those which are weak, to which worms always attach themselves more than to healthy plants, also plants in pots. Seedlings of all kinds are much injured by them; because, when the point of the taproot is cut through, the seedling has no other resource, and unless it be vigorous enough to throw out lateral roots it dies.

To destroy worms is fortunately a very simple process; for such is the tenderness of their skin, that watering them with any caustic or bitter liquid deprives them of life in a few minutes. The cheapest caustic liquid is lime-water, which is made by dissolving half a pound of quicklime in 12 pints of water, and letting it stand a few minutes to clear. Before pouring it on the soil from a watering pot with a rose on, the worm-casts ought to be removed, when the effects of the water will soon become obvious, by the worms rising to the surface, writhing about there, and in a few minutes dying. To hasten their death, some more lime-water should be poured on them after they come to the surface. The quantity of lime-water required will depend partly



on the depth of the soil, and the number of worm-casts in a given space, and partly on the state of the weather. Least will be required in shallow soils, moderately dry; and most in deep soils, either very wet or very dry. When lime is not at hand, potash, soda, or urine may be used; and a decoction of the leaves of walnut trees, of those of hemp, tobacco, or potatoes, after being partially dried and fermented, will have the same effect. Hand-picking may also be resorted to; but this requires to be performed in the nighttime, when the worms are on the surface of the ground, or immediately after rain. Worms in pots may either be removed by striking the sides of the pots which will disturb the worms, and cause them to rise above the surface, or by turning out the ball on the one hand, and picking off the worms, which seldom fail to come to the outside. To prevent worms from entering pots, a small cap (*fig. 34.* of the natural size) has been invented by Mr. Barron, which, when placed over the hole in the bottom of the pot, admits the escape of water, and effectually prevents the entrance of worms. It has been in use at the gardens at Elvaston Castle for several years. Oyster shells may be used as substitutes for this cover.]

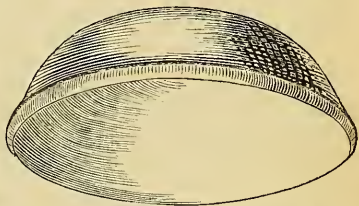

Fig. 34. Cap for covering the Holes in the Bottoms of Pots.

---

ART. VII. *On the Hornet.* By JOHN WIGHTON, Gardener to Lord Stafford.

HAVING troubled you on different occasions with communications about bees, I have now some observations to make on hornets. During the season before last, a hornet took possession of an empty beehive in the apiary of these gardens, which stood beside other hives containing bees. When I first observed the nest of the intruder, it was about the size of a pigeon's egg cut in half. It was fixed inside to the top of the hive, and then contained three cells. Two more cells were added on the following day, and an egg deposited in each of the five. In about four days the eggs were hatched; but in the mean time more cells were formed with an egg in each, and the nest of course enlarged. When I turned the hive upside down to examine the nest, the hornet always seemed afraid, and would skulk behind the nest: but after the brood came forth, the hornet lost all fear, and I began to think of the old saying, that nine hornets could sting a horse to death, and I thought it prudent to watch the opportunity when the hornet went abroad, to examine the nest.

May observes that the giant inhabitants of the vesparry live in union with those of the apiary: but, fearing that the case might be otherwise, when more hornets were produced, with a view to limit their numbers, I pricked all the brood except three, and part of the eggs with a pin. I supposed that the old hornet would take no notice of this; but was surprised to find the nest entirely forsaken. The following day I observed the hornet near the spot, looking out for another place of settlement. I kept the forsaken grubs alive for some time, by feeding them with food obtained from the larva of wasps, by causing them to reject it from their stomachs upon a feather. This I offered to the young hornets, who devoured the fluid greedily. I tried them with sugar, honey, and other sweet things, but nothing succeeded like the food obtained from the young wasps. The grubs grew till the cells could hardly contain them. With a view to remedy this inconvenience, I lengthened the cells with paper, but that did not answer the purpose; the grubs fell out; and here ended my endeavours to rear hornets.

There are two things in the above statement which may deserve notice; the fierceness of the hornet after the brood came forth, and the nest being afterwards forsaken. The fierceness of the insect at that particular time is in accordance with what appears to be an established law in other parts of the animal kingdom. The common hen, when she has young, will attack a mastiff. If the hornet's subsequently forsaking the brood appears inconsistent with her fierceness in defending it, we can only conclude that insect affection is, after all, less powerful than that of birds and quadrupeds. As it may be supposed that the hornet perished by some accident, and that the second one I observed was not the same insect, I may mention that I did the same, in the next season, to another hornet, and with the same result; its nest was forsaken.

I am not aware if entomologists have noticed a change in insects when their brood comes forth; and have no treatise to refer to at present, except the work of Buffon, and a few extracts from Reaumur. I find little worth notice in the former, who repeats the ridiculous story that a hornet will attack and devour a sparrow. The extracts from Reaumur are on wasps; and he gives some curious accounts how they feed their brood; which might lead one to suppose that his domesticated wasps, as they are styled, had not the usual covering to their cells, or that openings were made for inspection. This reminds me of a thing which I never could discover; how hornets and wasps enlarge the paper-like enclosure of their cells, which is properly called the nest. For instance, the one of which I have been speaking, when first discovered, was about the size of half a pigeon's egg; and if it had not been disturbed, it would probably have

increased to the size of a large turnip. This could have been effected only by adding coatings to the outside, and cutting away the interior layers, so as to afford space for increasing the number of cells: but, as I never could discover the insects in the act of carrying out the material thus cut away, I can only conjecture that they work it up for the structure of the additional cells, as they proceed. By this contrivance the cells are always carefully protected. It is certain that when the nest has attained the usual size, the coatings are more close and compact than while the nest is in progress. I lately examined a very large hornet's nest, and found the cells enclosed by eight or ten layers of a substance like paper. This the insect may be often seen collecting from dry, unpainted wood; its mouth being admirably adapted to the purpose.—*Cossey Hall Gardens, March 7. 1841.*

---

ART. VIII. *Further Results of the Experiments on the Application of Charcoal, as a Mixture with Earth, for the Cultivation of Plants in Pots.* By M. EDWARD LUCAS, Assistant Gardener in the Royal Botanical Garden at Munich.

(From the *Garten Zeitung* for 1840, p. 66.)

ACCORDING to my promise, I now lay before my readers the experiments I have made in the application of charcoal to another purpose, viz. using it as a mixture with various sorts of earth. It showed here also the same extraordinary effect; and all the plants that have hitherto been subjected to this treatment have been as much distinguished by their luxuriance of growth, as by the more perfect developement of their individual parts. This was particularly the case with tuberous-rooted plants, which, besides their perfect developement, had also a much longer period of vegetation; so that the difference in this respect, between those that were cultivated in their usual soil and those which had a mixture of charcoal, amounted to nearly two months. I was led to this by several trifling circumstances.

A very suitable treatment introduced into this botanic garden of plunging pots with bulbous or tuberous rooted plants taken up every year, for a few weeks after potting, or till they begin to shoot, in a moderate hotbed, covering them an inch deep with earth, was applied the previous year. A bed which had been used for sowing the seeds of tender plants in pots, and in which charcoal ashes were used for plunging them in, was appropriated to receive the newly planted species of *Arum*, *Begonia*, *Gésnera*, *Gloxinia*, and *Scitamíneæ*. The pots with these tubers were plunged to the rim in the frame containing the charcoal ashes, and then covered over with loose mould from a dung bed.

Before I proceed further, I cannot refrain from recommending this method, which, to my knowledge, has not been long known

in German gardens, to all cultivators; for nothing is more contrary to the nature of those plants, than to set them in the open greenhouse to make their first shoots, where they are consequently in a dry situation. Most of them, when treated with a gentle equable warmth, like that of a previously used dung bed, will be much more fine than if placed in a higher and drier temperature. Watering the tubers before they begin to grow is very disadvantageous, and yet it would be absolutely necessary if the pots stood in a greenhouse; we prevent the evil by making the earth in which the tubers are to be set sufficiently damp, only slightly pressing them down, and immediately covering them with earth in the dung bed. Only when the latter begins to dry, it should be moistened all over with the watering-pot; and this operation should be continued till all the tubers have made shoots, and then each can be watered singly. With respect to preserving them through the winter, I have to observe that these tubers, as soon as they are taken in, should be placed in the greenhouse, not too near the glass, and the earth covered with moss, by which they will be prevented from drying up too soon, and the necessity of moistening the earth obviated. By such treatment, want of success in the cultivation of these splendid ornamental plants can never be complained of. But to our subject.

These tubers, plunged in the ashes, soon shot up vigorously. As they ought to be grown in a high frame in summer, but which could not be immediately prepared, they remained in this low bed, which was only raised, dug up, and kept covered with earth. They absorbed a great deal, and required watering every day. When they were taken up, most of the roots, as may be supposed, had grown over and under the pots; they had penetrated into the charcoal, and grown so strong, that it was absolutely necessary to replant the tubers in pots considerably larger in size. I, of course, mixed charcoal with the earth in which they were to be planted, in the proportion of rather more than half. All the above-named species showed extraordinary luxuriance under this treatment; some were particularly rich in their inflorescence, and the green of their leaves was much more intense; in others, the period of flowering was of unusually long duration, so that while others planted in the usual soil had long ceased flowering, these continued to vegetate freely. Very small tubers, from which in the first year no flower was to be expected, flowered very beautifully, as was the case with *Gésnera atrosanguínea*. The *Aróideæ*, namely those with spotted leaves, such as *Calàdium píctum*, *C. bícolor*, *C. dícolor*, *C. spléndens*, *C. pœ'cile*, *C. hæmatostígmum*, *C. versícolor*, &c., excited universal admiration. Several species of *Billbérgia* and *Tillándsia*, to which I also added charcoal, soon exceeded in luxuriance those that were growing in common earth. From what was

before said of the *Cácti*, it may easily be supposed that they would flower well in a mixture of charcoal, which experience confirms. *Héchtia*, *stenopétala*, which rooted so quickly as a cutting, has since thriven equally well in a mixture of charcoal. The splendid Mexican euphorbias, such as *E. fastuòsa* and *E. fùlgens*, showed a very considerable power of growth. Orange trees with yellow leaves, having had a layer of charcoal laid on after the upper surface of earth had been removed, soon recovered their green] colour: this was also the case with gardenias. We need not be very particular as to the quantity to be used, half charcoal may be used without injury; only care must be taken, as before noticed, that the charcoal should be exposed for a time to the influence of the weather, and the larger pieces removed; and watering should never be neglected, as the greater porosity of earth causes it to dry up sooner.

A very interesting circumstance took place with an old and very sickly plant of the *Doryánthes excélsa*. After this plant had been falling off for two years, and in reality had no roots but one old and decayed one, it was planted in charcoal, and in the course of three weeks it began to shoot, and is since perfectly recovered; it is growing in a soil of one third charcoal.

Ferns sown on fine sifted charcoal germinate quickly and well; a number of species come up in the charcoal beds where seed falls, and not only *Gymnográmma macrophýlla*, and *Ptèris serrulàta*, but other rarer and more valuable species.

A friend of mine in the neighbourhood of Munich uses charcoal ashes for mixing instead of sand, and he assures me that all plants, chiefly hothouse ones, and among the cassias, particularly those with pinnated leaves, acacias, bignonias, &c., succeed extremely well, and have recovered wonderfully from their previous sickly state.

My esteemed principal, the court gardener, M. Seitz, who acknowledges the importance of this use of charcoal, is now putting in practice a number of systematic experiments with different sorts of charcoal, on all the families of plants, and it will only be at the conclusion of these extensive observations, which in spring are to be extended to garden beds, that a well-grounded opinion on the application of charcoal ashes in general can be formed.

---

ART. IX. *Remarks on the Application of Charcoal to the Growth of Plants.* By M. W. NEUBERT, Tübingen.

(From the *Garten Zeitung* for 1840, p. 110.)

IN reference to the communications of M. Lucas, on his experiments of rooting cuttings in charcoal, I take the liberty of

communicating my experience on the subject. My experiments are not numerous, and I should have considered them too trifling when compared with those of M. Lucas, if in one important respect they had not proved the very contrary of his, namely, with respect to the number of roots.

In the year 1831 I made several experiments to cause *Prímula prænitens* to produce blue flowers, as is frequently the case with *Hydránga horténsis*. After several unsuccessful attempts I had recourse to charcoal earth, such as is frequently found in woods where charcoal has been burnt. I took a plant of *Prímula prænitens* about two or three months old, with a very small ball of earth to the roots, and planted it in charcoal earth, where it grew luxuriantly, but instead of the flowers being blue they were of a bright red. A friend, who was interested in my experiments, thought the cause of my failure in this instance was owing to the plants having a ball of earth when planted, on which account the charcoal could not take proper effect. To ascertain if this were the case, I took some pure charcoal ashes, and planted a cutting of *P. prænitens* in it, which grew in a short time, and produced many beautiful red flowers. As I use very small pots for my experiments, on account of want of room, I am soon obliged to transplant my cuttings; after a full quarter of a year I took the primulas out of the pots to transplant them, but I found, to my astonishment, very few roots, and I therefore replanted them in their old pots, in which they remained from spring 1832 to spring 1833. When transplanting my other primulas in spring 1833, I also transplanted these, and found that, after being in the charcoal ashes a year and a half, they had not made so many roots as the others, which had only been planted half a year in common earth.

To examine the roots more closely, I shook away the whole ball, and found that the plant had three main roots, which were furnished with fine fibres and spongioles, and from the stem to the point were of a bright red colour, like the flowers.

This discovery was of great importance to me, as, by this treatment, frequent transplanting and the use of large pots were obviated. From this time I planted my primulas in charcoal ashes mixed with one half sandy bog earth, in small pots, in which they grew well, and produced abundance of flowers. The cuttings grown in 1832, in charcoal ashes, are still alive, and have stems  $1\frac{1}{2}$  ft. high, which have always fine crowns of leaves and flowers. I transplant these plants every autumn, always in the same 2-inch pots, take away the half of the ball of roots, and any side shoots that are beginning to appear, and keep them tolerably moist.

These favourable results induced me to mix charcoal with earth for various plants, and I always found that the plants were

very healthy, and rooted easily in it, but did not produce many roots, as was the case with M. Lucas, but, on the contrary, very few. Perhaps the cause of the difference lies in the sort of charcoal used; M. Lucas used fir charcoal, and I beech charcoal. It is very desirable that more experiments should be made with different sorts of charcoal, to find what effect the different sorts have on the same species of plants.

Besides primulas I have made experiments in charcoal with leaves of *Gloxinia*, *Streptocarpus Réxii*, *Gésnera bulbosa*, *Crassula*, *Cotylèdon*, and *Asclèpias carnosa*, all of which rooted very soon; also with twigs of *Hydrangea hortensis*, *Citrus*, *Justicia*, *Verbena*, *Trachelium cæruleum*, *Pelargonium*, *Passiflora*, and some *Aloes*, *Stapelia*, and *Cacti*, which also grew extremely well. I was completely unsuccessful, on the contrary, with *Rhododendron*, *Plumbago capensis*, and English garden primroses.

I must also observe that I had no dung or tan bed for my experiments, but at first kept my pots in a common living-room, and for the last few years only have used a small green-house under the same roof as my dwelling-house.

Although these trifling experiments have had no important results, they may serve as an encouragement to amateurs, as they show that no particular or extensive preparations are required for putting them in practice.

---

ART. X. *On the Protection of Flowers in the Open Ground, &c., from Snails and Slugs.* By W. WALKER, Esq.

I ENCLOSE you a description of an apparatus of my invention, and which I, and several gentlemen in our neighbourhood, have found effectual in practice. The original, of which the enclosed is a copy, was laid before the Society of Arts in 1839; but, as I find the *Transactions* of that Society have only a limited circulation, I conclude that a great majority of the cultivators of valuable plants (who are the parties to be the most benefited by the invention) may possibly never see the article referred to. This induces me to forward it to you for insertion in the *Gardener's Magazine*; and, as the season has arrived when its value may be appreciated, if you will have the goodness to give the same early publicity you will the more oblige, Yours,

Hull, March 15. 1841.

W. WALKER.

---

In the *Advertiser* of the 26th ult. appeared an article, by F. R. Horner, Esq., M.D., Hull, on this subject, which was copied from the *Gardener's Chronicle*. Dr. Horner acknowledged in that article that he was indebted for the suggestion of the principle to a scientific gentleman of this town. Mr. Walker, 54. Lowgate, is the gentleman alluded to, who has requested us to insert the following letter, addressed to Arthur Aikin, Esq., Secretary 1841. — IV. 3d Ser.

to the Society of Arts, dated as far back as June, 1839, upon the same subject:—

“Hull, 54, Lowgate, June 26. 1839.

“You will receive herewith, carriage paid, an apparatus of my invention, which, if you will have the goodness, at an early period, to lay before the Society, in order that those who consult your valuable work may have the benefit, I shall be greatly obliged.

At this season, any invention that will perfectly secure our dahlias, or other more delicate plants, from the attacks of those voracious pests of the flower-garden, the Mollusca, must be highly acceptable. No one has had to contend with a more formidable array of this class than myself, particularly the genera *Helix* and *Limax* of Linnæus; and I am happy to inform you, that the galvanic plant-protector above mentioned, and sent herewith, forms an effectual barrier against these formidable enemies.

I have had them in use in my own garden for twelve months, and can assure you that, although during that period plants on all sides have suffered from these creatures severely, not a plant has been injured that has had the protection of the galvanic circle.

The annexed drawing and description will exhibit the apparatus and explain its operation. The galvanic plant-protector consists of a taper or conical ring of zinc, of the following dimensions: 6 in. diameter at top (*a b*), the bottom (*c d*)  $4\frac{3}{4}$  in., and the height (*a c*) 4 in. The top edge is flanged off about a quarter of an inch, and cut into numerous zigzag or vandyked points, as represented in the drawing. Immediately under this pointed flange another ring, but of copper (*E F*), is neatly fitted, being exactly of the same taper as the former, and full 1 in. broad (*b F*), supported in its place by dots of solder in three or four places of its circumference: these dots are represented by the marks *z z*. Such is the apparatus: its operation is thus:—The bottom of the zinc ring (*C d*) being pressed into the soil until the lower edge of the copper ring is about  $1\frac{1}{2}$  in. above the surface, the Mollusca may crawl up the zinc with impunity, but, on coming in contact with the copper, will receive a galvanic shock, and immediately turn away, or fall to the ground. I have repeatedly watched them, and have observed they were extremely cautious in approaching a second time. I prefer the vandyked edge to a plain one, for this reason, if the larger of this tribe attempt to stretch across and above the copper belt, avoiding contact, they would be incapable of holding by the points. In fixing the galvanic plant-protector, care must be taken to enclose within the ring the rods, with such plants as require them, as represented in the drawing, otherwise the Mollusca would find a ready road to the plant by the rod. The apparatus acts in wet or dry weather, and is therefore always in action. Its appearance in use is like a flower-pot, and its cheapness, utility, and durability must insure its general adoption.

I believe the same principle may be applied to walls for the protection of fruit trees, straps of zinc and copper being judiciously placed along the wall, and around the stem of each tree; the best position, in my opinion, would be an angle of  $45^\circ$  with the wall. Suppose *a b*, in the annexed figure, to represent the section of a wall, *c d* the strap of zinc and copper, *e b* the ground line; the angle *c d b*, I think, should be about  $45^\circ$ . In this arrangement the copper should clip the edge of the zinc strap, *c*.

In addition to the security from snails, &c., I believe

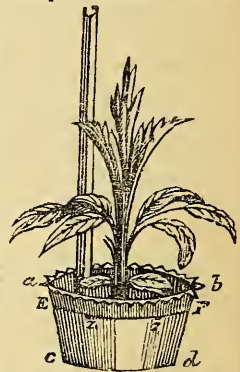

Fig. 35. Galvanic Plant-Protector.

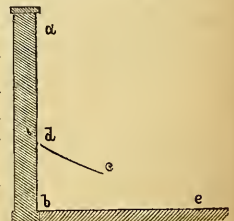

Fig. 36. Galvanic Protector for Fruit Trees on Walls.



that that most destructive insect, the *Forficula auricularia* *Linnaeus*, could not pass from under the barrier (*c d*) without using its wings. I apprehend they could not hold by their feet to the zinc in its position *c d*, but would fall to the ground in attempting to pass from *d* to *c*.

The practice of placing small flower-pots, filled with dry leaves, in an inverted position over the tops of plant-rods is well known, and adopted for capturing these insects. The zinc strap is admirably adapted to bring the same system into practice for the protection of wall trees, thus: suppose, along the edge of the zinc strap next the wall, holes to be made, about an inch in diameter, one, two, or more yards from each other, and these closed by loose covers, of a shape capable of being easily removed, and of holding dry leaves; the gardener, by walking round his walls once a day, would be enabled to secure great numbers of this destructive tribe, particularly during the season before they take wing. This arrangement, I believe, would operate thus: an insect creeping up a wall or stem of a fruit tree meets with obstruction at *d*, and, being prevented from proceeding in that direction, instinctively runs horizontally along the angle, in search of an outlet, when it very soon enters one of the openings with its cover full of leaves, the kind of shelter in which it delights; others follow, until the spaces between the leaves are full. I think this is not too much to expect, for in either direction the angle forms a channel to conduct the current of insects into the very reservoirs where the gardener wishes to find them. I am not certain that the galvanic arrangement operates on these dry animals, but on the moist tribe *Mollusca* it does powerfully. I must now take leave of the subject, and beg to subscribe myself,

Sir, respectfully, your obedient Servant,

WM. WALKER.

Arthur Aikin, Esq., the Secretary at the Society  
of Arts, Adelphi, London."

Sometime before receiving the above communication we had prepared the following paragraph from two articles which appeared in the *Gardener's Chronicle*.

The sensation of galvanism is produced by placing in contact plates of zinc alternating with plates of copper, with a piece of moistened cloth between each. This forms what chemists call the galvanic battery; and it is by exciting this chemical power in its simplest and feeblest form, that the efficacy of the galvanic protector depends. If a snail or slug be placed on a plate of zinc, to which a narrow plate or strip of copper is fixed near the edge, and the zinc turned over it so as to form a rim of zinc, copper, and zinc, it creeps unmolested on its surface; but as soon as it touches the rim where the copper is it receives a galvanic shock (its moist soft body acting as the moistened cloth above mentioned, and thus forming the galvanic circle complete), and immediately recoils, twisting itself back, and rarely venturing a second time to touch the copper, to receive another shock. To protect a crop or plant, then, it is only necessary to have a zinc plate of sufficient length to surround it, of 5 or 6 inches in breadth, with a strip of sheet copper 1 in. broad riveted to the upper part of the strip of zinc, and the zinc turned over it so as to form a rim, as shown in *fig. 37*. The plate so prepared is to be set on edge round the bed or plant to be protected. The cost of the plates complete is said to be about 6*d.* a lineal foot,

so that a circular plate to enclose a space 6 in. in diameter will cost about 9*d.*, or allowing 2*d.* for uniting the two extremities, 11*d.* We have had one circular rim made by Messrs. Cottam and Hallen, Winsley Street, Oxford Street, with the copper on the inside instead of the outside, and, having enclosed a number of snails and slugs in it, we find them, hitherto, effectually imprisoned. This we conceive to be a more efficient test of the galvanic influence than employing it to protect a plant; because, in the latter case, the creature may turn for food elsewhere, but in the former it must starve if it does not cross the galvanic boundary. — *Cond.*

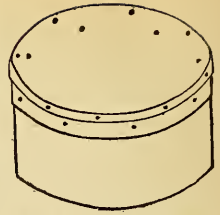

Fig. 37. *Galvanic Plant-Protector.*

ART. XI. *On the Incombustibility of the Larch.* By H. L. L.

EVELYN, towards the conclusion of his account of the larch, alludes to a supposed peculiarity in the wood of that tree to resist combustion. He refers to the story of a castle besieged by Cæsar, and preserved from conflagration by logs of larch wood heaped around it, and he introduces the line

Et robusta Larix, igni impenetrabile lignum.

From the context, these words have been supposed to be an extract from Cæsar, and have been since quoted (*Arboret. Brit.*, vol. viii. p. 2358.; *Library of Useful Knowledge*, art. Planting, p. 125., &c.) repeatedly, as if from the works of that author. But neither the story of the Castle of Larignum, nor even the word Larix, is to be found in any of the writings of Cæsar now extant; and with regard to the line above mentioned, having lately met with it accidentally, I am enabled to state that it belongs to the *Parthenice* of Baptista Mantuanus, not far from the beginning of the poem,

Omne quod excellens opus et sublime futurum  
 Difficiles ortus habet, incrementaque tarda.  
 Sic Junco nemus Alcidæ—sic tardior exit  
 Populeis Abies ramis—sic Abiete Pinus (? Prunus)  
 Segnior, et Pruno longe vivacior Ilex,  
 Et robusta Larix igni impenetrabile lignum.

It is certainly possible that Vitruvius may have derived his very circumstantial story of the Alpine castle from some portion of Cæsar's writings which has not come down to us; but the only occasion on which that conqueror encountered any opposition among the Alps is known to have occurred in his passage of the Mount Genève, at the very beginning of his Gallic campaigns, and we have his own brief account of that affair.

Evelyn seems to entertain some well-founded suspicion upon this alleged incombustibility of the larch, and refers to the note of the editor of Vitruvius Philander, who, it appears, put the veracity of his author to the test, by trying the experiment at Venice, and igniting a piece of larch in the presence of his Mæcenas (Cardinal D'Armagnac), then ambassador to the republic.

It remains to be ascertained whether these stories of the impossibility of igniting the larch, narrated by Vitruvius and other Roman authors, be not so many more instances of the *larix* being confounded with the alerce (*Thùja articulàta*) of Africa, (see *Gard. Mag.*, vol. xiii. p. 512.). Perhaps, also, the submerged ship described by Witsen may, from its locality in the Numidian Sea, be presumed to have been built of the African alerce, rather than of the European *Làrix*.

March, 1841.

---

ART. XII. *Description of a Mode in which Mushrooms may be grown under the Paths of a Hothouse.* By W. JONES, Gardener to I. M. D'Ollier, Esq.

IN November last I considered it necessary to make some alterations in a plant stove, the principal feature of which was the raising of the whole interior surface 14 in. higher than it originally was. Having completed the front and end passages, a thought occurred to me, that the vacuum in the rear might be filled to advantage with a mushroom-bed, placing bearers for planks to rest on, as a substitute for the tiles with which the passage was laid. I accordingly set to work, filled in and beat (with a pavier's rammer) four successive layers of half-dried unfermented horse-droppings. When done, I had 8 in. of this material as hard as a Wicklow black turf. The length of the passage alluded to is 30 ft. by 3 ft. wide; so that six 1½-inch planks, 15 ft. long by 1 ft. wide, cover the bed so completely that nothing is to be seen but the level passage all round; and this, so far from being unsightly, I think adds much to the appearance of the house, as heretofore this part of the house was rather damp, which is frequently the case in houses where the fire enters at the flues, and passes along the front. In this house it goes along the front twice, and once along the back; so that the water used in front to subdue the too great aridity of the atmosphere, rising in vapour, falls condensed in this as being the coldest part of the house. The planks absorb this humidity, and look neat and clean. The bed itself, which is the finest and most productive I ever saw, can be examined or watered without the least inconvenience, by raising the planks on their edges; if they be soiled, they can be laid on the flue and washed, or they

may be coloured to correspond with the tiles. A bed can be made on the same principle in any back passage which is not too dry, nor the temperature too high (it should not exceed 60°), with a neat step at each end, upon a lighter scale, say 10 in. high, 5½ in. for dung, 1½ in. for earth, 1½ in. for mushrooms to swell in, and 1½ in. for thickness of planks. All this can be removed in spring, when the crop is gathered. Beds treated in the manner I have described will never give out any gases or effluvia calculated to offend the olfactory senses of the most delicate female. I only intend these few hints for those who have not the convenience of a proper structure solely allotted for the production of this vegetable; for sometimes the best of us fail in producing a good supply in sheds in the dead of winter.

*Boosterstown, near Dublin, Feb. 10. 1841.*

## REVIEWS.

ART. I. *Catalogue of Works on Gardening, Agriculture, Botany, Rural Architecture, &c., lately published, with some Account of those considered the more interesting.*

A *HISTORY of the Vegetable Kingdom, embracing the Physiology, Classification, and Culture of Plants, with their various Uses to Man and the lower Animals, and their Application in the Arts, Manufactures, and Domestic Economy.* By William Rhind. Parts I, II., and III. 8vo. Glasgow, 1840.

This work is written as a part of one entitled *The History of the Earth and Animated Nature*, and appears, from the following quotation, to be on a comprehensive plan:—

“In treating of the vegetable kingdom, the same simplicity of arrangement and perspicuity of description will be observed which characterise the excellent work of Dr. Goldsmith. The first portion will embrace the physiology of plants, and include a description of the structure and uses of the various parts, together with general views of vegetable culture, the geographical distribution of species, and the economical products which vegetables afford. The remainder of the work, under a simple and natural classification, will contain descriptions of particular plants, including those used for food, clothing, architectural purposes, and for the ornament and convenience of social and domestic life. In this department will be found all that is curious and novel in the vegetable kingdom. The full and popular manner in which the different subjects will be treated, and the mass of original and collected information, will, it is presumed, render this work superior to any of similar extent and character at present extant. For the illustration of the text, a very extensive series of engravings and woodcuts is in preparation. The work will be included in eight parts, price 2s. each, to form a handsome volume.”

There are some well executed plates in the parts before us, and a number of woodcuts; and the letterpress seems creditable to the author; but of this we shall be better able to judge when the work is farther advanced. The work is cheap, and on that account, independently of others, deserves to be successful.

*Flowers and their Associations.* By Ann Pratt, author of “*The Field, the Garden, and the Woodland.*” 12mo; coloured plates and woodcuts. London.

A most agreeably written book, by a lady evidently well acquainted with her subject, and impressed with its importance in cultivating the young mind, by teaching it how to observe, and leading it to reflect. It forms one volume

of the *Library for the Young*, now publishing by Mr. Knight, and, like all that gentleman's publications, is excellent and cheap.

*A Series of Botanical Labels for the Herbarium, adapted to the respective Floras of Smith, Hooker, Lindley, Macreight; including One for every Plant hitherto recognised as indigenous to the British Islands.* Edited by a Corresponding Member of the Botanical Society of London. 8vo. London. 5s.

Those who are engaged in forming collections of dried British plants will find this volume a valuable storehouse of correct labels, which they can cut off and attach to the paper on which their specimens are fastened. The annexed is a specimen of a label.

|  |  |      |
|--|--|------|
| ROSACEÆ Juss. ICOSAN. POLYGN.                  |  |      |
| FRAGARIA MOSCHATA Duch.                        |  |      |
| FRAGARIA elatior Ehrh.                         |  |      |
| <i>Hautboy Strawberry</i> — Groves and hedges. |  |      |
| Loc.   |  |      |
| TEM.   |  | COL. |

*A Treatise on an improved Mode of cultivating the Cucumber and Melon, so as to produce early Melons and Cucumbers all the Year with less Trouble and Expense than by the Methods usually practised. With Directions for growing and forcing Asparagus and Sea-kale; and for destroying Woodlice.* By George Mills, Gardener to the Baroness De Rothschild, at Gunnersbury Park, Middlesex.

In these days, when so many of our first-rate gardeners are occupied with the Orchidææ, it is satisfactory to find one of the heads of the profession cultivating the cucumber, and teaching the amateur how he may produce them in a frame or pit all the year round. It appears to us that one grand cause of Mr. Mills's success is his employment of sandy peat, *alone*, as soil for his plants in the winter season, without any mixture of rotten dung or leaves. The peat, or heath soil, never retains water, and consequently never generates a damp atmosphere, which is more or less the case with every other description of soil; even thoroughly decomposed hot-bed dung, or leaf mould, both of which are used by the Dutch in their winter forcing of the cucumber. Our more humid winter atmosphere seems to require a drier soil than that of the winters of Holland, and M. Mills seems to have hit upon it. Pines are grown in the same soil at Versailles, as shown at p. 17.

## MISCELLANEOUS INTELLIGENCE.

### ART. I. General Notices.

*COVERING Strawberry-Beds with Netting* stretched on a frame at a short distance from the ground checks radiation, and consequently increases the temperature of the surface of the bed. There is no doubt that much may be gained by coverings of netting in early spring, from their effect in retaining both heat and moisture, whether by checking radiation, or diminishing the effect of cold and drying winds. At the same time, during very hot weather, the net will diminish the effect of the sun's rays, and when the soil has been cooled by too much rain, the net, if not removed, will prevent warm and drying winds from having their full beneficial influence. Coverings of netting, therefore, will, under certain circumstances, require to be occasionally taken off for a few hours during the finest part of the day, and afterwards put on again.—*Cond.*

*American Blight (Aphis lanigera).*—Many prescriptions have from time to time appeared in the *Gardener's Magazine* for the American blight. Oil destroys the insect, but is hurtful to the tree. Vitriol reduced to the consistency of sour drops (about seven parts of water to one of vitriol, according to the

strength of the vitriol), if applied by rubbing well into the crevices of the wood, wherever the kind of hoariness produced by the insect is perceptible, we have found in practice to destroy the insect without hurting the tree : it is very penetrating. Hot water is apt to cool before reaching those insects that are in very inaccessible crevices. — *R. L. Kilmarnock, Feb. 4. 1841.*

*Pince and Co.'s permanent Botanical and Horticultural Tally*, mentioned in

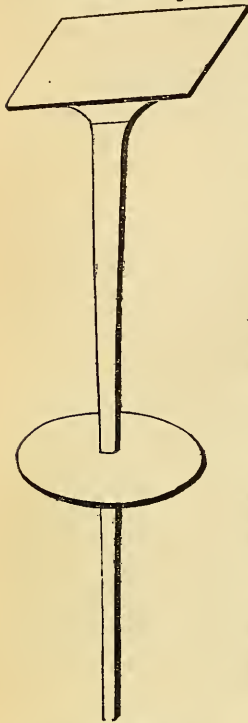

Fig. 38.  
Tally for Trees and Shrubs. \*

p. 86., is shown in *figs. 38, 39.*; the former is a perspective view, and the latter an elevation of the cast-iron shank. The length of the shank from the disk to the neck is 1 ft., and below the disk 8 in. The width of the shank at the neck is rather more than an inch, and at the lower extremity three fourths of an inch. These shanks can be afforded by Messrs. Cottam and Hallen at 4*s.* 6*d.* per dozen, or with a lead plate riveted on, as in *fig. 38.*, at 8*s.* per dozen. The size of the name plate will depend on the number of words which are to be stamped or painted on it. These plates may be formed of sheet lead one eighth of an inch thick, and the letters stamped with steel type, and filled in with white lead, the body of the plate being painted black ; or they may be made of wood thoroughly dried, soaked in oil, painted black or a blue black, and the letters painted white. The disk, on firm ground, such as turf, will prevent the tally from sinking too far into the soil, or leaning to one side. On the whole, this tally promises to be one of the best hitherto devised for arboretums.

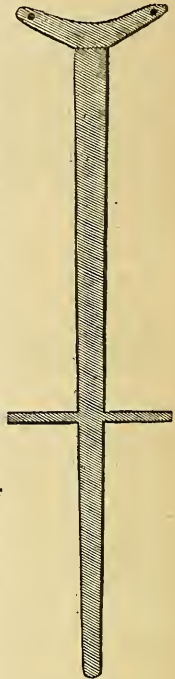

Fig. 39.  
Shank of Tally for  
Trees and Shrubs.

*New Besom for Garden Purposes.* — Mr. G. Duncan, gardener at Levenside, always uses the twigs of the snowberry (*Symphoria glomerata*) for sweeping walks, &c., which he prefers to either birch or broom, as being more tough, durable, and easily obtained. The snowberry is a hardy free-growing plant, that will thrive in almost any situation, even under trees it grows well ; so that a ready supply of material for making besoms might be provided by planting it in any unfrequented place near the garden, where it could be cut when wanted, which should be done as soon as the wood is properly ripened, and tied up in bundles to dry before it is made into besoms for use. — *L. Glasgow, Feb. 10. 1841.*

## ART. II. Domestic Notices.

### ENGLAND.

*CHURCHYARDS at Lancaster.* — Since you were in this neighbourhood, we have had some new churches built ; and I consider the plans of the churchyards deserving of notice in the *Gardener's Magazine*, as they are calculated to meet the approbation of both rich and poor who may wish to cherish dear remembrances. — *D. Saul. Lancaster, Feb. 1841.*

*Queen Pines cut at Prestwold in October 1840, by Mr. Brown, Gardener there.*—I take the liberty to send you the weight of ten queen pines which were cut by my father, at Prestwold, last October. To some the weights may appear almost incredible, but others as well as myself can vouch for the authenticity of the list.

|        | lb. | oz. |    | lb.     | oz. |   | lb. | oz.    |   |   |    |
|--------|-----|-----|----|---------|-----|---|-----|--------|---|---|----|
| First  | -   | 5   | 9  | Fifth   | -   | 4 | 6   | Eighth | - | 4 | 4  |
| Second | -   | 5   | 4  | Sixth   | -   | 4 | 5   | Ninth  | - | 4 | 4  |
| Third  | -   | 4   | 14 | Seventh | -   | 4 | 4   | Tenth  | - | 4 | 12 |
| Fourth | -   | 4   | 8  |         |     |   |     |        |   |   |    |

The ten together weighing 46 lb. 6 oz. good weight. When I was with Mr. Cruickshank at Coleorton, we cut two queens there which weighed 5 lb. each, and that was the greatest weight we ever got the queen to attain. As the old flue system, together with its old companions wooden lights, has succeeded in growing such (I may say) fine fruit, what may we yet look for from the effect of metallic glazing, and hot water, which I think are far preferable?—*W. Brown. Merevale Hall, Feb. 12. 1841.*

*The Bokhara Clover.*—We have had plants from 12 to 14 feet high, and have saved from them a considerable quantity of seeds. Horses and all other cattle and sheep are very fond of this plant, the smell of which is exactly like that of *Anthoxanthum odoratum*. It is a biennial, and its strong fleshy roots decaying rapidly in the soil will add to its richness, and form a sort of manure for the succeeding crop. I could say much more in favour of this plant, but I have not time.—*R. Forrest. Kensington Nursery, Oct. 29. 1840.*

### SCOTLAND.

*Glasgow Botanic Garden.*—The site of the old garden, which was bought for 2000*l.* in 1817, has lately been sold for 12,000*l.*, and 22 acres farther from town in a most beautiful situation have been purchased for 4400*l.* This new garden is at present being laid out, and there can be no doubt that when completed it will form by far the most beautiful botanic garden in Scotland.—*A. B. Glasgow, April 6. 1840.*

*Jelly from the Berries of Ribes sanguineum.*—A pot of jelly made from the berries of this shrub was exhibited at the autumn meeting of the Caledonian Horticultural Society, by Mr. James Kellock, gardener to Mr. Younger, of Craigielands, Moffat, who received a premium. (*Edinburgh Courant*, Sept. 10. 1840.)

*Names of African Plants.*—At the meeting of the British Association at Glasgow, Dr. Walker Arnot read a paper to show that a vast number of different names had been given to many plants of the same kind; and expressed a hope that some arrangement would be adopted by which the confusion thus created might be removed. (*Lit. Gaz.*, Oct. 31. 1840.)

---

### ART. III. Retrospective Criticism.

*MR. PENN'S Practice in Heating, &c.*—In answer to your enquiries as to the success of my system of warming and ventilating hothouses, I beg to say that I have been in general very successful; but, in some instances, there has been a deficiency of heat during the last most severe and trying winter, which I find has happened not only to my system but to every other. The experience of this winter has proved to me the expediency of putting the heating-pipes in the front instead of the back of the houses; and I also find it preferable to have the pipes in a casing above the ground floor, rather than under it. I have this winter tried the pipes uncovered, which I think, in some cases, superior to covering them. In some cases where I have put up apparatus, I have found some slight alterations in the replacing the pipes, &c., necessary; which I find myself called upon to make without any expense to my employers.

I have lately heated a new house, 300 ft. long, and 40 ft. wide, for T. Ashton Smith, Esq., it was not finished till the latter end of November, when the bricks and mortar were all very wet and cold, as well as the ground and drains. The apparatus was put to work as soon as finished: of course it was not to be expected that there would be a sufficient quantity of heat at first, which has been the case in this most extraordinary severe winter; this is not at all surprising at a time when there has been a general complaint of want of heat under all systems.

I shall feel great pleasure in showing any gentlemen my houses and plants; they will then be convinced that the fault is not in the system, though at first I think it was not applied by me in the most beneficial manner.—*John Penn. Lewisham, March 15. 1841.*

*Mr. Penn's Mode of Heating and Ventilating Hothouses.*—From the account you gave of it in the *Gardener's Magazine* for March, 1840, and my high opinion of the author, I was inclined to become quite a convert to the system, but a recent visit to the seat of T. A. Smith, Esq., Tidworth House, Hants, has quite altered my views on the subject.

Mr. Smith being a gentleman of immense wealth, and particularly attached to horticultural pursuits, had allowed the system to be adopted to great extent under the immediate superintendence of Mr. Penn, sparing no expense and grudging no sacrifice, to give the system a fair trial. The result, I am sorry to state, terminated in utter disappointment. The heated air from the tubes in place of revolving, as shown by the arrows in your section, Vol. for 1840, fig. 19. p. 122., remained perfectly stagnant and stationary at the top of the house; and in place of being a "uniform revolving heat," as stated by Mr. Penn, was in reality remarkably partial, and deficient of the desired temperature, had it been general; as a proof of which, during the late frost the houses and pits were completely covered with a sheet of ice and snow, except a small space at the top directly over each of the tubes (which in this instance were situated inside); the branches of the peach trees enjoying the warm air from the mouths of the tubes were in full blossom, whilst the other branches showed not the least symptoms of excitement; at the same time, the houses and pits requiring a higher temperature could not be raised above 40°, the frost at that time amounting only to 10°. This deficiency, I understood, was at first attributed to the improper attention of the men in charge of the fires. One of Mr. Penn's foremen was immediately sent down, who, after sitting up all night, succeeded in only maintaining a lower temperature than the regular attendants, under similar circumstances. The fuel used there is the anthracite coal. Lest the desideratum should have arisen from fresh damp materials, absorption, and the like, a patient and protracted trial of a couple of months was still persisted in, after which the necessity of abandoning the system was deemed indispensable. The exposed pipes and movable sashes are now resumed and accompanied by their anticipated favourable results. A little reflection might possibly convince any one of the impracticability of keeping the sashes screwed down, as advised, during a scorching summer's day. The powerful boiler erected by Mr. Penn still remains, and is much approved of, performing that work with ease, which, during the concealment of the pipes, it was incapable of.

A large span-roofed conservatory, 300 ft. in length by 40 ft. in breadth, has during the past autumn and winter been erected at Tidworth House, for the culture of both horticultural and floricultural productions, and also to furnish an agreeable retreat and promenade for the family during the winter months. The interior contains two large longitudinal beds, or borders, interrupted by a circle of gravel and a transverse walk in the centre of the house, one broad gravel walk in the middle, and two narrower ones on either side. It is heated by Mr. Penn from one large boiler; the hot-water pipes are arranged under the centre of the two borders, transmitting heated air to the house by means of cylindrical metallic tubes, about 20 ft. apart; a line of circular gratings in the centre of the three gravel walks, intended to receive the cold air, com-



municate with the transverse drains in the interstices of the tubes. They succeeded with great difficulty in keeping out the frost during the late severe winter, and now the season is further advanced, and the weather more clement, the plants and vegetables look remarkably well, reflecting great credit on Mr. Saunders, the gardener, who is a young man particularly assiduous and persevering in his habits, and of very superior ability.

It must be distinctly understood that no perceptible current of revolving air was ever discovered either in this or the former-mentioned structures, during the closed state of the sashes, (naturally an ascent of heated air from the tubes to their vertex, amounting, perhaps, to an agitating current, but no revolution,) consequently ventilation was resorted to, and is continued in the usual way, and it is expected, before another winter ensues, the pipes will be exposed, and thus a due chance of the requisite emission of heat afforded them.

It was glazed by Mr. Drake, with British sheet glass, which gives it a remarkably neat and elegant appearance; but the laps being entirely closed with putty, or other cement, an immense drip of condensed vapour is the consequence, which evil, it is thought, will lead to the tedious expedient of reopening the laps. — *G. C. March 11. 1841.*

On this communication we have to observe that we recommended Mr. Penn's mode of heating on the following grounds: 1. because it had attained what always has appeared to us a very desirable object in hothouses (see *Encyc. of Gard.*, edit. 1824, p. 313.), the complete circulation of the air within, without admitting any air from without, and without diminishing its moisture: 2. because Mr. Penn authorised us to state (see our Volume for 1840, p. 128.) that, in any case in which he was employed, if he were not successful, he would reinstate the houses as he found them, at his own expense; so that no gentleman by trying his plan could be any great loser: and 3. knowing Mr. Penn to be a man of probity and property, we felt confident, as we now do, that he would be able, as well as willing, to keep his word.

That Mr. Penn has not been successful either in producing sufficient heat, or in effecting a complete circulation of the air, in more than one instance, is a fact which cannot be denied; but, as he has been most successful in the case of his own houses, and also in those of Mr. Wilmott, the fault is evidently not in the principle, but in its application. Having brought Mr. Penn's system into notice, however, we must leave it to work its way among other systems; and, though we are satisfied that the circulation of the air in hothouses is an advantage, and that the system of cross drains which Mr. Penn adopts is the best hitherto devised for this purpose, yet we by no means expect that every gardener is to agree with us in opinion. We know that there are some who set little value on the circulation of air among plants, except in the case of setting fruits; but we have never been among that number. Independently of the plants, the advantage of a circulation, in all houses which are to be walked into in order to examine the productions, will not, we think, be denied, except by those who wish to deprive Mr. Penn's system of all merit whatever. Were Mr. Ashtou Smith's conservatory ours, we would try Mr. Penn's system two or three times, before we would give up the advantages of air in motion to walk in.

It will be seen by a previous communication from Mr. Penn, as well as in the article by M. N. T., in our January Number, p. 42., that Mr. Penn has made several improvements in his arrangements, one of the greatest of which is placing the pipes in front, and another is placing those in the middle of span-roofed houses in an uncovered drain or box, with which the cross drains communicate. With respect to a passage in the above communication in which the writer speaks of "the impracticability of keeping the sashes screwed down, as advised, during a scorching summer's day," we can only say that, if any thing of this kind has been advised by us, we are in error; if Mr. Penn has advised it it is rather singular, because in the summer season he always opens the top sashes of his own houses. If the writer alludes to us, it must be to the following passage: "When it appears desirable to change the air of

the house, this is not done by opening the sashes in the usual way, but by taking the stoppers out of openings, &c., in the drain containing the hot-water pipes, and communicating with the open air." (*Gard. Mag.*, 1840, p. 122.) This passage, it should have been stated, refers only to winter treatment, the article having been written in February.—*Cond.*

*Mr. Penn's Mode of Heating at Chatsworth.*—In our Volume for 1840, p. 578., we have stated that an orchidaceous house at Chatsworth is "being heated by Mr. Penn," and we have given a section of the house. Mr. Penn, as well as some other correspondents, has called our attention to the following paragraph in the *Gard. Chron.* for January 30. "There is no truth in the statement mentioned by a constant reader, that either the orchidaceous house or the vast conservatory at Chatsworth is heated upon Mr. Penn's plan. We strongly advise him not to adopt this much-talked-of method of heating, concerning which we shall have some observations to offer in our next number." (*Gard. Chron.*, Jan. 30. p. 73.) We were aware of the paragraph, but did not think it worth notice, being satisfied of the truth of our assertion in the passage to which we have above referred. Mr. Penn, however, looks upon it in a different light, and requests us to state that he has heated an orchidaceous house at Chatsworth, and that it has given satisfaction; in proof of which he has shown us a letter from Mr. Paxton, from which we extract the following passage: "I have great pleasure in being able to express my entire satisfaction as to the efficiency of heat at command, and the general working of this excellent method of heating in the houses here. I perceive it is creating a great stir in Loudon's *Magazine*, but people will continue to write about what is a riddle to themselves."—(Signed) *Joseph Paxton. Chatsworth Gardens, Jan. 13. 1841.*

See, on the same subject, Mr. Main, in p. 208.

*Mr. Niven's Stove for various Purposes.* (p. 49.)—I am surprised to find that any man with the slightest pretensions to practical knowledge in any of the departments of gardening should ever venture, in 1841, to propose, and far less to advocate, the adaptation of one house for so many purposes; and, according to his own account, with the most sanguine expectations of success in all. Should therefore the result be such as Mr. Niven holds out, and the public are given to expect, we may bid farewell to any thing like extensive ranges of glass being put up in future. Really one would suppose that, instead of Mr. Niven having been in the habit of enlightening the horticultural world with something new, either in his tasteful suitable erections as a garden architect and landscape-gardener, or superior system of management, as one would be led to expect from his former, and I believe present, practice as a superintending practical gardener, he had just awakened out of a comfortable sleep, which he had been snugly enjoying for these last thirty or forty years, and had written his article before he was quite awake; so far does he appear to be in the wake of the march of improvement on most of the topics he has advanced. For example, Mr. Niven talks of the youth of queen pines started at two years old! Why, any practical gardener who knows any thing at all of growing pines would rarely have a two-year-old queen pine in his house; as, under judicious management, with even the old-fashioned bottom-heating medium of tan, with all the risks of burning, as it is called, the queen pine will produce a better fruit, yes, a heavier fruit, and I will vouch as well flavoured, at eighteen months as ever Mr. Niven's would; and I will allow him to add another year to his too early fruiting plants, with all the advantages of his bed of nutritive matter, as a medium for planting in, as well as his magazine of moist heated air into the bargain.

Again, Mr. Niven, speaking of the guava (*Psidium Cattleyanum*), hopes that it will prove an interesting and desirable addition to the dessert. Why, *Psidium Cattleyanum* has been proved to be what he, Mr. Niven, hopes to see it; and was sent to table as a dessert fruit in the neighbourhood of London, and also to the tables of many of the nobility and gentry throughout England, a dozen years ago.

Not only, also, does Mr. Niven's horticultural stove exceed any thing heretofore erected in its suitability to all sorts of vegetable productions, but in the manner in which it expedites their perfection: as, for instance, in regard to the cucumber, Mr. Niven affirms that, in six weeks from sowing, cucumbers were cut from 18 in. to 2 ft. in length!

In conclusion, I beg to observe that there is nothing I should more desire than to meet in competition with Mr. Niven and his pipe-heated vine borders, with one which I should lay down on the old-fashioned plan, which, for Mr. Niven's information, I will state in detail. It is as follows: let the border be excavated 12 ft. wide, 3 ft. deep at the wall of the house, sloping to 4 ft. at the walk, along the side of which is to be made a drain to carry off all superabundant water. Let then the bottom be pared and beaten as smooth and firm as it possibly can be made. Then fill in a layer of any dry rubbish, brickbats, if to be had, to the depth of one foot. Over this let there be closely fitted a sod, of from two to three inches thick, with the grass side down, and over that the compost. The materials, and the component parts of which being a matter of opinion, I shall leave every one to judge for themselves. Thus the border, when finished, would in compost be 2 ft. deep at the wall of the house, and 3 ft. at the walk. A border prepared and planted after this method, protecting the stems and roots with litter in winter and early spring forcing, I will engage to furnish as well ripened wood, to produce as early and as abundant a crop, and as well flavoured fruit, as Mr. Niven can possibly do with his expensive pipe-heated border. Nay better; for I am convinced that to heat pipes encased in the earth, so that their influence shall be felt one foot from the drain or cut in which they are laid, will cause the earth to become baked to that consistency that every particle of that nutritious matter which constitutes the food of the plant would be utterly destroyed.—*Cattus. Belfast, March 9. 1841.*

*Comparative Temperature of different Years.* (p. 147.)—I have perused with much pleasure, and I trust some profit, the ingenious article on the subject of temperature by N. M. T., though I differ from him in some particulars. In the first place, instead of the average temperature not varying more than half a degree, it will be found to vary as much as 5°; so that the seasons would appear to be not "invariably alike," but rather invariably unlike. A warm summer does not always follow a cold winter; though this is frequently the case. It is more certain that a series of cold seasons is succeeded by a series of hot ones. I do not think plants can be acclimatised. They are, in my opinion, immutable in their natures. A stunted exotic will bear, for instance, more cold than one grown so as to exhibit its natural vigour; but take a cutting from it, grow it as it grows in its native country, and it will be found to possess its original susceptibility. Seedlings, even without crossing, do vary; and by always selecting the hardiest, a little may be done in the way of acclimatising, in the course of successive generations, but not much.—*N. London, Feb., 1841.*

*Architectural Objects in Gardens.*—You cannot think how cordially I agree with you in the opinion that no architectural object ought to rise out of dug ground. To baskets, rustic objects, rockwork, and almost every thing, I apply the same rule, and so outrageously fastidious am I on this point, that, in English or turf gardens, I cannot bear to see even shrubs do so; even the dug clumps in the grounds I fill so that the plants overstep, as it were, their bounds, and kiss the turf on each side, and cut or train them so as to maintain their form perfect; but I detest to see that form marked out by a staring piece of sodden earth. I could almost quarrel with you for digging round the hillocks in the Derby Arboretum.—*N. M. T. Feb. 1841.*

The hillocks alluded to are not to be dug, but only to be covered with short grass till the plants are so far grown as to render this care unnecessary. (See *Gard. Mag.* for 1841, p. 542.)

*Shriveling of Grapes.*—In p. 170. I observe an article on the shriveling

of grapes, by Mr. R. Errington, in which, I think, he misrepresents the article by me in p. 45.; and, presuming that the Magazine is open for mutual discussion upon gardening topics, I take this opportunity of forwarding a few remarks on Mr. Errington's paper, as far as it relates to mine. In the first place, he states that Mr. R. Wilson "has had a vinery, in which, whilst the atmosphere in the house was West Indian, the roots were at the same time undergoing all the rigours of a Siberian winter." Now this I do not mean to deny, but I would like to know what Mr. Errington would have done if he had been placed in similar circumstances. Let him suppose himself at the foot of the north side of the Carter Fells, a range of hills, or rather mountains, which divides the counties of Northumberland and Roxburgh, with a large vinery just on the point of coming into flower, which he had to attend to during a truly Siberian-like winter night. In such a manner I was situated in March 1837. The previous month was very mild and fine weather, as was all the spring, taking it in a general view; but, if Mr. Errington will take the trouble of referring to the several meteorological journals for March, 1837, he will find that there were eight days of continued frost in London, commencing on the 19th. Now, let him think what it would be in Scotland, where nature does not bless us with such mild winters as you have in England. I find on comparing my journal with the article by me in the Magazine, that I have made a mistake in stating that the external thermometer stood at 13°; it was at 18° upon the 24th of March, 1837; and I mentioned it only as an evidence against Dr. Lindley's opinion quoted by W. H. Mr. Errington, after alluding to the Siberian winter which he says our vine roots were undergoing, adds, alluding to me, "now this he has done three successive years;" but, if he will take the trouble to examine my paper, he will find that I never so much as alluded to such a thing. I said that we never had a shriveled grape during the three years I was at Edgerston. Mr. Errington afterwards states that I said that by these means I obtained the medal at the Jedburgh Society; this also is erroneous; and, in making the assertion, he has fallen into just the very error that he complains of your Cotswold correspondent committing, namely, jumping at conclusions, which, by the by, I think he ought not to have mentioned when we take his own conclusions into consideration. I had it not in my power to take medals; as I was at the time alluded to, in 1837, foreman under Mr. Thomas Weir, who is allowed to be one of the best forcing gardeners in the South of Scotland. As I am upon the subject of the shriveling of grapes, which certainly is an important one, I may be pardoned for giving my opinion on it once more. As I stated before, I do not think that it proceeds from coldness of the outside border; that, of course, will have a tendency to weaken the vine, but it has nothing to do with shriveling. Nor do I acquiesce with W. H. in supposing that it proceeds from the richness of the border. I have seen a good many vineries, where I considered the vines over-luxuriant, in different parts of the country; and, when such is the case, the vines are generally long-jointed and unfruitful; but, in my humble opinion, in many such instances, even that might be obviated by proper pruning, and ripening the wood well in the autumn. In any house under my charge, I should not like to be tied to either one or two modes of pruning, which, I presume, ought to depend entirely upon the habit of the vine. In fact, I do not believe there is one case out of ten, where shriveling proceeds from the border at all. In most instances it is the want of proper attention to heat and air, at that particular period of the growth of the grapes when they commence colouring; and, where there is a miscellaneous collection of vines in one house, that period is attended with no small risk. What strengthens my opinion is, the disease is not so prevalent in Scotland as it is in England, and consequently artificial means are to be the more relied upon, such as fire, &c. In fact, by superior growers, the fires are never dropped at all, applying either less or more, until the fruit is all cut, and the wood well ripened; so that the atmosphere is always dry, which is so essential to the proper culture of the vine, as soon as the grapes commence colouring. Of the vineries that I alluded

to, p. 45., the first was usually started about the first of January, and the next in April.—*Robert Wilson, gardener to W. Grey, Esq. Norton, March 6. 1841.*

*Transmission of Cuttings by Post.*—In p. 88. I observe a note respecting the transmission of cuttings by post, wherein it is recommended to wrap them in tin-foil. I consider the employment of this substance quite unnecessary; for the only danger is that of the cuttings being broken, should the letter be crushed or doubled across its length, and against a force that would effect this, the tin-foil would afford but little if any resistance.—*D. Saul, Lancaster, Feb. 1841.*

---

ART. IV. *Queries and Answers.*

*PREVENTING Hares and Rabbits from injuring the Bark of Trees.*—A correspondent in p. 96. enquires whether there is any preparation which will prevent hares and rabbits injuring young trees. I have used very extensively a mixture of soot and milk, and found it very successful. The soot and milk should be well mixed together till they are of the consistency of paint, and applied with a brush to the stems of the trees when the weather is dry. I have used it for some years in the plantations here, where previously the ash trees, even of considerable size, were much gnawed by the hares and rabbits. The black colour which remains upon the trees for two or three years is of no consequence in a plantation, though it might be objectionable in a pleasure-ground or shrubbery.—*W. Leveson Gower, jun. Titsey Place, Godstone.*

*To prevent the Ravages of Hares and Rabbits on Forest Trees.* (p. 96.)—To one gallon of coal tar add 3 lb. of hog's lard, increasing it to any extent, applying it with the hand or a painter's brush (the former I consider best) to the height of 4 or 5 feet. This will prove an effectual remedy, such being their aversion from tar, that, were a circle drawn round a tree at a small distance from it, they will rarely or never enter it. I need not add, this will not in the least injure the trees.—*John Fish. Colney House, Hertfordshire, Feb. 12. 1841.*

*Felling resinous Trees.*—What season do you consider the best for cutting down the timber of the spruce fir, Scotch pine, and other resinous trees?—*W. L. Gower, jun.*

We should say any time in the course of the winter months, the sap being then in a comparatively dormant state. In Sweden, and in the Alps and Pyrenees, resinous trees are felled during summer as well as winter, not because it is the best season, but because it is the most convenient one. See *Arb. Brit.*, vol. viii. p. 2135. We shall be glad to hear the opinions and practices of practical men in Britain on this subject.—*Cond.*

*Painting Vines with Clay.* (p. 96.)—Allow me to ask Mr. Fish whether painting vines with clay, soft soap, and sulphur, is a cure for the curl, as well as a preventive of the hatching of the eggs of insects?—*W. Wilson. Bragden Gardens, Northumberland, Feb. 15. 1841.*

---

ART. V. *Biography of the late Mr. William Beattie, F.H.S.*

FROM the commencement of the *Gardener's Magazine* it has been usual to notice individuals who have distinguished themselves in the profession, and to offer some tribute of respect to their memory when they have been removed by death from the sphere of their usefulness, to the regret of their friends and of those who have either benefited from their advice, or profited by their instruction; to few could such a mark of respect be offered with more propriety than to the late *William Beattie, F.H.S.*, who, for a long series of years conducted the gardening and foresting departments, as well as the improvements generally, on the extensive estates of the Right Honourable the Earl of Mansfield, at Scone, near Perth. I have long expected that some of his pupils more competent than myself would have performed the task which I have

undertaken; but, as no one has felt it to be his duty to do so, I beg to supply the omission by the accompanying memoir, for the particulars of which I am partly indebted to his nephew, my friend and fellow-pupil at Scone, Mr. Booth, now the gardener and general superintendent at Carclew, Cornwall.

The subject of this brief notice was born at Wasthill in the parish of Old Rain, Aberdeenshire, in 1758, and from being an only son was originally intended for the church; with this view his early years were passed at the parish school, where he obtained a far more liberal education than usually falls to the lot of those who even at the present day adopt the profession of a gardener; and to this very circumstance did he often look back with great satisfaction, and ascribe much of the success and happiness that attended him through life. Just as his friends had made arrangements for sending him to college he had the misfortune to meet with a serious accident which confined him for a long time, and ultimately had the effect of completely altering his future plans and prospects; the delicate state of his health rendering a change advisable, he removed to the neighbouring parish of Moneymusk where some of his friends resided, and there he formed the resolution of becoming a gardener. Sir Archibald Grant, justly celebrated as one of the greatest planters of his time, and of whom Scotland has reason to be proud, was then carrying on extensive alterations at his seat; and, considering this would be a good school, he made application, and was successful in gaining admission to the gardens of Moneymusk, where he served his apprenticeship; on its expiration he went to Edinburgh, and was employed at Arniston, the seat of the then Lord President Dundas, at that time a noted place for young gardeners. From thence he went to London, with letters of introduction to his countrymen, Mr. Malcolm, the eminent nurseryman at Stockwell, and Mr. Forsyth of the Apothecaries' Garden at Chelsea; and, by means of their recommendation, he soon succeeded in obtaining the situation of gardener to the Marquess of Bute, at his seat in Hampshire: but the greater part of the time (nearly twenty years) which he resided in England, he acted as land-steward and gardener at Losset Hall in Yorkshire, and to the Duke of Dorset, at Knowle in Kent. His intimacy with Mr. Forsyth continued until the death of the latter, in 1804; it was entirely through that gentleman he was introduced to the late Earl of Mansfield, and received his appointment to Scone, where he lived for nearly thirty-four years. The formation of the gardens, and conducting of the very extensive alterations and improvements during this long period, at that princely place, will remain for many years as a proof of his talent and ability. He was kind and considerate to those employed under him; and I believe nothing gave him more real pleasure than to see his young assistants endeavouring to improve themselves in matters regarding their profession, or to hear of their good success in life after they had left Scone. On his retiring from the arduous duties of his situation in 1837, the late Lord Mansfield not only allowed him to retain his salary, but presented him with several articles of value. Amongst the latter, an elegant silver box, engraved with an inscription expressive of his esteem and regard. Indeed all the members of that noble family were unremitting in their attention to him during the remainder of his life.

He was a corresponding member of the Caledonian Horticultural Society, and a fellow of the Horticultural Society of London, to both of which he contributed one or two papers, which are published in their *Transactions*. He was married, but had no family, and died on the 2d of April, 1839. His remains were interred in the churchyard at New Scone, (as well as those of Mrs. Beattie who survived him only twelve months,) near to the monument now erecting by public subscription to commemorate the unfortunate Douglas, who was also at one time his pupil and assistant. — *James Duncan. Basing Park, Alton, Hants, March 3. 1841.*

---

THE  
GARDENER'S MAGAZINE,

MAY, 1841.

---

ORIGINAL COMMUNICATIONS.

ART. I. *List of Plants adapted for a Conservative Wall, with Remarks on some of the Species.* By JOHN SCOTT.

IN accordance with your wish, expressed on the cover of the *Gardener's Magazine* for Dec. 1840, I have forwarded to you a list of plants calculated for a flued (or otherwise heated) wall, with the means of protection, similar to that at Chatsworth. I have arranged it according to the natural system; but I have omitted the sub-orders on purpose, in order to shorten the article as much as possible. I am afraid you will think that it is still too voluminous, and, perhaps, that I am too sanguine with regard to some of the species; but, as I have not inserted any plant upon the authority of others, but have confined myself to my own knowledge and experience on the subject, I send it with the greater confidence. As it may be asked whence I drew my experience, I answer, that the greater portion of my life has been devoted to the pursuit of botany and gardening. Early taught to range the mountain steep in search of plants, I naturally imbibed a taste for them; for, at the age of 14, I had acquired, perhaps, more hard names than generally fall to the lot of gardeners. At that period the names were chiefly cryptogamic; but since then a much wider sphere of botanic research and floricultural action has been my hap.

Bred in some of the best plant gardens of Europe, I have had an opportunity of becoming acquainted with thousands of species little known to some of my brethren of the spade. Amongst these gardens, that of Edinburgh was a field rich with interest and instruction to me, and particularly in the kind of plants composing my list; and it was from the herbarium and notes I made there, and at Biel in East Lothian, that I have principally been able to compile it; although I have pressed into my service many species from other collections, indeed, wherever I may have seen them tried out. At Clermont, under Mr. M'Intosh, I had facilities of testing a great many kinds, both in the open borders and against the walls. Nor have I been inattentive in visiting the nurseries around London, and in gleaning what information I could on this very interesting subject. But the most important collection, and that which abounds in the greatest number of species, and from which I have drawn liberally, is the *Jardin des Plantes* at Paris, numbering about 18,000 kinds. Here I had an opportunity of reconsidering nearly all that I had known before on the subject; and, although I have perhaps enumerated some species little known in England, yet our communication with our neighbours is so easy, that they may soon be procured. Thus far I have endeavoured to show that my list is not founded upon a theoretical, but upon a practical basis; and, should it be the means of causing even one more plant to be cultivated out of doors, I shall feel more than repaid for having furnished it.

Here I had intended to have made a few remarks upon the building, heating, and general management of a conservative wall, but I find that I must postpone these to a future opportunity.

*Milford Nursery, Jan. 28. 1841.*

Those species marked with a star (\*) are the more hardy; those with a dagger (†) the most so.

- Ranunculàcææ.*  
*Clématis L.*  
 †*chinénsis Retz.*  
 \**japónica Dec.*  
 †*flórida Thunb.*  
 †*flòre plèno A. B.*  
 \**Sieboldti D. Don.*  
 \**cærùlea Lindl.*  
 \**crísipa B. M.*  
*Winteràcææ R. Br.*  
*Illícium L.*  
 \**floridànum Ellis*  
*anisàtum L.*  
*parviflòrum Michx.*  
*Wintera Willd.*  
*aromática Willd.*  
*Magnoliàcææ Dec. Syst.*  
*Magnòlia L.*  
 †*grandiflòra L.*  
 †several varieties.  
 †*glàuca L.*  
 †*conspícua Salis.*  
 †*purpùrea B. M.*  
 †*grácilis Par Lond.*  
 †*fuscàta Andr.*  
 †*pùmila Andr.*  
*Dilleniàcææ Dec.*  
*Hibbértia L.*  
*Cunninghàmia R. Br.*  
*volùbilis L.*  
*dentàta B. R.*  
*grossulariæfòlia B. M.*  
*Schizandràcææ Arb. Brit.*  
*Schizàndra Michx.*  
*coccínea Michx.*  
*Kadsúra Willd.*  
*japónica Willd.*  
*Menispermàcææ Dec. Pr.*  
*Cócculus Bauh.*  
 \**carolinus Dec.*  
*Menispérmmum L.*  
 †*canadènze L.*  
 †*dàuricum Dec.*  
 †*smilàcinum Dec.*  
*longifòlium Hort. Par.*  
*Berberàcææ Lindl.*  
*Bérberis L.*  
 †*dúlcis Sw.*  
 †*rotundifòlia Hort.*  
 †*empetrifòlia Lam.*  
 †*dealbàta B. R.*  
*Mahònia Nutt.*  
 \**fasciculàris Dec.*
- \**nervòsa Nutt.*  
 †*Aquifòlium Nutt.*  
 †*rèpens G. Don*  
 And probably all  
 the new sorts sent  
 home by M. Hartweg.  
*Nandìna L.*  
 †*doméstica L.*  
*Fumariàcææ Dec. Syst.*  
*Adlùmia Dec.*  
 \**cirrhòsa Dec.*  
*Cruciàcææ Arb. Brit.*  
*Mathiòla L.*  
 \**fenestràlis Jacq.*  
*Cheiránthus L.*  
 \**mutàbilis B. M.*  
*frutésceus Pers.*  
 \**finifòlius Dec.*  
*Ibèris L.*  
 \**semperflòrens (?)*  
*gibraltàrica B. M.*  
*Lepídium L.*  
 \**graminifòlium Cav.*  
*Æthionèma Dec.*  
 †*membranàcea Hort.*  
 \**corifòlia H. Paris.*  
*Moricándia Sw.*  
*arvensis Sw.*  
*Vélla L.*  
 †*Pseùdo-Cýtisus L.*  
*Zilla Dec.*  
*nyagròides Dec.*  
*Cràmbe L.*  
*fruticòsa Dec.*  
*Capparidàcææ Lindl.*  
*Cápparis L.*  
 \**spinòsa L.*  
*ovàta Desf.*  
*ægýptia Delil.*  
*Resedàcææ Dec. Theor.*  
*Resèda Willd.*  
*glàuca Spreng.*  
*scopària Spreng.*  
*fruticulòsa Spreng.*  
*Cistàcææ Lindl.*  
*Cístus L.*  
*incànus L.*  
*cymòsus Dun.*  
*salviæfòlius L.*  
 \**latifòlius Sw.*  
*Heliánthemum Tourn.*  
 \**Libanòtis Willd.*  
 \**algarvènze Dun.*
- \**formòsum Dun.*  
 Many other species  
 are equally beautiful,  
 and well calculated  
 for the bottom of a  
 wall or rockwork.  
*Polygalàcææ Arb. Brit.*  
*Polygala L.*  
*oppositifòlia B. R.*  
*grandiflòra Lod. B. C.*  
*bracteolàta B. M.*  
*speciòsa B. R.*  
*Muráltia Dec.*  
*Heistèria B. M.*  
*míxta B. M.*  
*Múndia Dec.*  
*spinòsa Dec.*  
*Pittosporàcææ Arb. Brit.*  
*Billardièra Sm.*  
*scándens Sw. Fl. Aust.*  
 \**longiflòra B. Mag.*  
*mutàbilis B. M.*  
 \**ovàlis Lindl.*  
*Sóllya Lindl.*  
*heterophýlla Lindl.*  
*linearis Lindl.*  
*angustifòlia Lindl.*  
*Pronàya Lindl.*  
*élegans Lindl.*  
*Pittòsporum Banks*  
 \**Tobìra Ait.*  
*fol. variegàtis Hort.*  
*undulàtum B. R.*  
*tomentòsum Bonp.*  
*hírtum Willd.*  
*Bursària*  
*spinòsa B. M.*  
*Frankeniàcææ Dec. Prod.*  
*Frankènia L.*  
*corymbòsa Desf.*  
*Caryophyllàcææ Arb. Br.*  
*Diánthus L.*  
*arbúscula B. R.*  
*fruticòsus Fl. Gr.*  
*caroliniànus.*  
 \**Caryophýllus L.*  
 \**fruticòsus Hort.*  
*Drypis L.*  
*spinòsa L.*  
*Linàcææ Arb. Brit.*  
*Linum L.*  
 \**flàvum Willd.*  
*trígynum L.*



- quadrifolium  
suffruticosum  
arborescens L.  
monogynum Hort.
- Malvaceæ* Dec. Prod.
- Málva* L.  
*scopària* Jacq.  
*capénsis* B. R.  
*aspérrima* Jacq.  
*miniàta* Cav.  
\**Creeàna* Hort.  
\**Munroiàna* B. R.  
*ròsca* Flor. Mex.  
*obtusiloba* B. M.
- Lavàtera* L.  
*acerifolia* Lois.  
*O'lbìa* Cav.  
*Pseùdo-O'lbìa* Poir.  
*triloba* B. M.  
\**marítima* Dec. Fl. Fr.
- Hibiscus* L.  
*hispidus* B. R.
- Bombaceæ* Dec. Prod.
- Plagiánthus* Forst.  
*divaricatus* Forst.
- Sterculiaceæ* Lindl.
- Stereúlia* L.  
*platanifolia* L.
- Byttneriaceæ.*
- Commersònia* And. Rep.  
*dasyphylla* And.
- Lasiopetalaceæ.*
- Thomàsia* Dec.  
*solanacea* Dec.
- Hermánia* L.  
*plicata* Jacq.  
*salvifolia* Cav.  
*scabra* Jacq.
- Mahérnia* L.  
*pinnata* B. M.  
*incisa* B. M.
- Tiliaceæ* Dec. Prod.
- Entèlea* B. M.  
*arborescens* B. M.
- Sparrmánnia* B. M.  
*africana* B. M.
- Elæocarpaceæ.*
- Elæocarpus* Burm.  
*cyaneus* B. B.
- Gordoniaceæ.*
- Stuártia* Willd.  
\**virginica* Willd.
- Gordonia* Ellis  
\**Lasiánthus* L.  
\**pubescens* Pursh
- Camelliaceæ.*
- Caméllia* L.  
*japónica* L.  
Many varieties.
- Thèa* L.  
\**viridis* L.  
*eurýoides* Lindl.  
*oleifera* B. R.  
*Sasánqua* Thunb.  
*maliflora* B. R.  
*reticulata* B. R.
- Aurantiaceæ* Hort. Lign.
- Citrus* L.  
*Médica*  
*Limétta*  
*Limònum*  
*ácida*  
*aurantium* L. §
- Hypericaceæ* Lindl.
- Hypéricum* L.  
*canariense* L.  
*pátulum* Thunb.  
*Uralum* B. M.  
*baleáricum* L.  
*rosmarinifolium* Dec.  
*empetrifolium* Willd.  
*Còris* L.  
*fasciculatum* Lam.  
And several others.
- Aceraceæ* Lindl.
- Acer* L.  
\**oblónum* Wall.  
*palmatum* Thunb.  
*Dodonæaceæ* Dec.
- Dodonæa* L.  
*triquetra* Andr.  
*asplenifolia* Rudg.
- Meliaceæ* Dec.
- Mèlia* L.  
\**Azédarach* L.  
*austràlis* Swt.
- A beautiful plant of this fine tree, that had attained the height of 18 ft. and 3 in. diam. was killed in 1838 in the Jard. des Plantes. It flowered profusely every year.
- Ekebérgia* Lam.  
*capénsis* Lam.
- Vitaceæ* Lindl.
- Cýssus* L.  
*capénsis* Willd.  
\**quinata* Ait.
- Killed at Paris to the ground in 1838.
- Tropæoleæ* Dec. Prod.
- Tropæolum*  
*aduncum* B. R.  
*pentaphyllum* B. R.  
*tricolorum* B. M.  
*brachyceras* B. M.
- Oxalideæ* Dec.
- Oxalis* L.  
*crenata* Hort.
- Zygophyllaceæ* Hort. L.
- Fagònia* Dec.  
*arabica* Dec.
- Lárrea* Cav.  
*nítida* Cav.
- Zygophyllum* L.  
*foetidum* L.  
*album* Dec.
- Rutaceæ* Dec. Prod.
- Rùta* L.  
*angustifolia* Pers.  
*albiflora* B. M.  
*chalapénsis* Hort. Par.
- Aplophyllum* Juss.  
*suaveolens* Don  
*linifolium* Don
- Adenádra* Willd.  
*uniflora* Willd.  
*speciosa* B. M.

§ These five species ought to be planted on a very porous subsoil or well-drained border, and exposed to the full sun in summer; for it is a mistaken practice of many to shade oranges during the summer months. On the Continent they are always exposed to the hottest sun, which is rational, as the wood has the advantage of being better ripened, and, is consequently enabled to resist the winter better.

- Empleurum  
 serrulatum *Sm.*  
 Corræa L.  
 álba *Andr. Rep.*  
 rûta  
 pulchélla *Sw.*  
 speciôsa *B. R.*  
 Zièria  
 Smíthü *Bot. Rep.*  
 Coriàcæ *Hort. Lig.*  
 Coriària *Niss.*  
 \*sarmentôsa *Forst.*  
 Celastræcæ *Dec.*  
 Eúonymus *Tourn.*  
 \*japónicus *Thunb.*  
 \*fòl. argént *Hort.*  
 \*fòl. aúreis *Hort.*  
 lúcidas *D. Don*  
 Celástrus L.  
 punctatus *Dec.*  
 tetragónus *Dec.*  
 Aquifoliæcæ *Dec. Prod.*  
 Cassine L.  
 capénsis L.  
 Hartôgia *Dec.*  
 capénsis L.  
 This is quite a distinct plant from what is generally sold in the nurseries for it, viz. a dwarf variety of common laurel.  
 Ilex L.  
 \*Perado *Lod. B. C.*,  
 fine species.  
 Dahdon *Willd.*  
 Cassine *Catesb.*  
 \*vomitoria *Jacq.*  
 speciôsa *Hort.*, very  
 fine foliage.  
 Rhamnæcæ *Lindl.*  
 Zízyphus *Tourn.*  
 Lótus *Desf.*  
 Spina Christi *Lam.*  
 nítida *Roxb.*  
 flexuosa *Wall.*  
 Phýlica plumôsa *H. B.*  
 Rhámmus *Lam.*  
 crenulatus *Ait.*  
 prinóides *L'Herit.*  
 Retanilla *Brongniart*  
 obcordata *Brig.*  
 Hovénia *Lam.*  
 acérba *B. R.*  
 Collètia *Kth.*  
 \*spinôsa *Kth.*  
 serratifòlia *Vent.*  
 Pomadérris.  
 \*prunifòlia *Hort.*  
 Colubrîna *Brongniart*  
 triflôra *Brong.*  
 Ceanòthus L.  
 \*azùreus *Desf.*  
 \*americânus L.  
 \*ovatus *Desf.*  
 \*intermèdius *Pursh*  
 nepalénsis *Wall.*  
 Brumiæcæ *R. Br.*  
 Brùnîa *Rœm. et Sch.*  
 ericóides *R. et S.*  
 formôsa *R. et S.*  
 Homalinæcæ *Lindl.*  
 Blackwèllia *Dec.*  
 fagifòlia *Dec.*  
 Aristotèlia *L'Herit.*  
 \*Máccqui *L'Herit.*  
 \*fòl. varieg. *Hort.*  
 Azàra *R. et Pav.*  
 \*dentata *R. et Pav.*  
 Anacardiæcæ *Lindl.*  
 Pistàcia L.  
 atlántica *Desf.*  
 Rhús L.  
 álbida *R. et S.*  
 lobata *Dec.*  
 Schínus L.  
 Mólle L.  
 Duvaúa *Kth.*  
 \*depéndens *Dec.*  
 latifòlia *Gill.*  
 \*dentata *Dec.*  
 Cneòrum L.  
 tricóccum L.  
 Leguminæcæ *Arb. Brit.*  
 Sophòra *Br.*  
 macrocárpa *Bot. Cab.*  
 velutina *B. R.*  
 Edwardsia.  
 \*grandiflora *B. M.*  
 \*chrysophýlla *B. R.*  
 \*microphýlla *B. M.*  
 Virgília L.  
 capénsis *B. M.*  
 áurea *L'Herit.*  
 †lútea *Michx.*  
 Although this fine tree is perfectly hardy, yet I think it deserves a place here from the beauty of its flowers.  
 Macrótropis *Dec.*  
 fæ'tida *Dec.*  
 inodora *Dec.*  
 Anagýris *Dec.*  
 fæ'tida *Lodd.*  
 latifòlia *Dec.*  
 Piptánthus *Sw.*  
 nepalénsis *Sw.*  
 Podalýria *R. Br.*  
 seríceæ *B. M.*  
 buxifòlia *B. R.*  
 Callistachys *Dec.*  
 lanceolata *B. R.*  
 Brachysèma *Br.*  
 latifòlium *B. R.*  
 undulatum *B. R.*  
 Gompholóbium  
 polymórphum *B. M.*  
 Jacksônia *R. Br.*  
 scopària *Lodd. B. C.*  
 reticulata *Dec.*  
 Viminària *B. M.*  
 denudata *B. M.*  
 Sphærolóbium *Smith*  
 vimíneum *Sm.*  
 Dillwýnia *Sm.*  
 junipérina *B. C.*  
 Eutàxia *R. Br.*  
 myrtifòlia *Br.*  
 púngens *Sw.*  
 Euchilus *B. R.*  
 obcordatus *B. R.*  
 Pultenæa *B. M.*  
 stricta *B. M.*  
 daphnóides  
 subumbellata (?)  
 Davièsia *B. M.*  
 latifòlia *B. M.*  
 mimosóides *H. K.*  
 ulcína *Andr. Rep.*  
 cordata *B. R.*  
 Mirbèlia *B. M.*  
 reticulata *B. M.*  
 dilatata *B. R.*  
 Hòvea *Dec.*  
 lanceolata *B. M.*  
 purpúrea *Sw.*  
 Célsi *B. R.*  
 Bossiæa *Vent.*  
 Scolopéndrium *Vent.*  
 rûfa *Dec.*  
 Goodia *Salisb.*  
 latifòlia *Sal.*  
 pubescens *B. M.*  
 Scóttia *H. K.*  
 dentata *H. K.*  
 Templetônia *B. M.*  
 retusa *B. R.*  
 gláuca *B. M.*  
 Lipària *B. M.*  
 sphærica *B. M.*  
 Priestlèya *Dec.*  
 villôsa *Lab.*

- vestita *B. M.*  
 Hállia *Dec.*  
 alàta *Dec.*  
 cordàta *Jacq.*  
 Crotalària *Dec.*  
 élegans *Hort.*  
 Loddigèsia *B. M.*  
 oxalidifolia *B. M.*  
 Anthýllis *L.*  
 Bárba Jòvis *L.*  
 Hermànnia *L.*  
 erinàcea *L.*  
 cytisòides *Dec.*  
 Ulex *L.*  
 austràlis *Clement.*  
 Genísta *Lam.*  
 elevàta *Poir.*  
 canariénsis *B. R.*  
 òmifolia *B. M.*  
 umbellàta *Poir.*  
 fèrox *Poir.*  
 monospérma *Lam.*  
 filipes *Webb*  
 Cýttisus *Dec.*  
 lanígerus *Dec.*  
 racemòsus *Hort.*  
 Adenocàrpus *Dec.*  
 hispànicus *Dec.*  
 Onònis *L.*  
 'críspa *L.*  
 Nàtrix *Dec.*  
 arenària *Dec.*  
 angustifolia *Lam.*  
 Medicàgo *L.*  
 arbòrea *L.*  
 òmifolia *Hort.*  
 Dorýcium *Dec.*  
 \*suffruticòsum *Dec.*  
 microphýllum  
 Lòtus *L.*  
 anthyllòides *Vent.*  
 atropurpùreus  
 jacobæus *B. M.*  
 créticus *Cav.*  
 Psoràlea *L.*  
 bituminòsa *L.*  
 glandulòsa *Schk.*  
 tenuifolia *Jacq.*  
 canescens *Dec.*  
 americàna *Jack.*  
 Carmichaèlia *R. Br.*  
 austràlis  
 Indigófera *L.*  
 austràlis *Willd.*  
 sylvàtica *Bieb.*  
 Dumàsia *Dec.*  
 villòsa *Dec.*  
 Dàlea *Dec.*  
 phymatòides *Dec.*  
 Tephrosia *Dec.*  
 sophoròides *Dec.*  
 hispídula *Dec.*  
 Amórpha *L.*  
 \*glàbra *Desf.*  
 \*nàna *Nutt.*  
 canescens *Nutt.*  
 Robínia *L.*  
 \*hispida *L.*  
 Coursètia *Dec.*  
 tomentòsa *Dec.*  
 Calóphaca *Fisch.*  
 \*wolgàrica *Fisch.*  
 Swansònia *Salisb.*  
 galegifolia *Brown*  
 coronillæfolia *Salisb.*  
 albiflora *B. R.*  
 Lessértia *Dec.*  
 procumbens *Dec.*  
 Sutherlandia *Brown*  
 \*frutescens *B. M.*  
 microphýlla *Burch.*  
 Astrágalus *Dec.*  
 cephalòtes *Pall.*  
 fruticòsus *Pall.*  
 Coronílla *Neck.*  
 júncea *L.*  
 \*valentina *L.*  
 \*glàuca *L.*  
 Hippocrèpis *Brit. Fl.*  
 baleàrica *Jacq.*  
 Hedýsarum *L.*  
 fruticòsum *L.*  
 Lespedèza *Michx.*  
 frutescens *Dec.*  
 Cliánthus  
 puniceus *Hort.*  
 E'benus *L.*  
 crética *L.*  
 Vicia *L.*  
 capénsis *Dec.*  
 Láthyrus *L.*  
 \*grandiflorus *B. M.*  
 \*latifolius *E. Bot.*  
 \*albiflorus *Hort.*  
 O'robus *L.*  
 atropurpùreus *Desf.*  
 Many other species  
 belonging to Vicièæ  
 (although hardy) are  
 particularly deserving  
 of a place on a con-  
 servatory wall. I have  
 only enumerated a few,  
 as representatives of  
 the tribe.  
 Kennèdya *Dec.*  
 rubicúnda *B. M.*  
 prostràta *B. M.*  
 Marryàttæ *B. R. ?*  
 coccínea *B. R.*  
 inophýlla *B. R.*  
 tricolor *B. R.*  
 pannòsa *Hort.*  
 dilatàta (?) *Hort.*  
 Comptoniàna *B. R.*  
 digitàta *B. R. (Hard.)*  
 Hugèlzi (?) *(Harden.)*  
 angustifolia (?)  
 glabràta *B. R. (Zich.)*  
 Jarràti *Hort.*  
 \*monophýlla *Vent*  
 longiracemòsa *B. R.*  
 \*nigricans *B. R.*  
 ovàta *B. M.*  
 Stirlingii (?)  
 spléndens *B. R.*  
 This splendid genus,  
 although not all equally  
 hardy, may with care be  
 preserved on a hot-wall,  
 especially the kennedyas  
 and hardenbergias. The  
 zichyas are more impa-  
 tient of cold, especially  
 tricolor and glabràta ;  
 this last will not stand  
 above 4° frost, whilst the  
 others will stand from  
 6° to 8°.  
 Rhynchòsia *Dec.*  
 difformis *Dec.*  
 Wistària *Arb. Brit.*  
 †frutescens *Dec.*  
 †chinénsis *Dec.*  
 \*Backhousiàna *Hort.*  
 A'pios *Dec.*  
 \*tuberòsa *Dec.*  
 Canavàlia *Dec.*  
 bonariénsis *B. R.*  
 Lupinus *L.*  
 \*arbòrea *B. M.*  
 mutàbilis *Sw.*  
 Cylísta *Dec.*  
 móllis (?)  
 Erythrina *L.*  
 herbàcea *B. M.*  
 laurifolia *Jacq.*  
 Crísta-gàlli *B. R.*  
 Mimòsa *L.*  
 \*prostràta *B. R.*  
 Darliungtònia *Dec.*  
 glandulòsa *Dec.*  
 Acàcia *Neck.*  
 \*armàta *Br.*  
 prostràta  
 strícta *Willd.*  
 \*melanóxylon *Br.*

farnesiàna *W.*  
 pubescens *Br.*  
 \**Julibrissin Willd.*  
 \*dealbàta *Link*  
 Ceratònia *L.*  
 \*Siliqua *L.*

Rosàcea *Dec.*  
 Amýgdalus *Tourn.*  
 †orientàlis *W.*  
 Cérasus *Juss.*  
 \*sinénsis *G. Don*  
 Púrshia *Dec.*  
 \*tridentàta *Dec.*  
 Kérià *Dec.*  
 \*japónica *Dec.*  
 flore-plèno *Hort.*  
 Rùbus *L.*  
 rosæfólius *Smith*  
 \*coronàrius *B. M.*  
 refléxus *Ker*

A very fine creeper, of easy cultivation; but very rare in collections.

Potentilla *L.*  
 \*glàbra *Lodd.*  
 Ròsa *Tourn.*  
 †odoràta *Hort.* vars.  
 †semperflorens *Lind.*  
 †Bánkisia *R. Br.*  
 flùtea *Lind.*

With hundreds of others at the taste and pleasure of the proprietors.

Lòwea *Lind.*  
 \*berberifòlia *Lind.*  
 Cratægus *Lind.*  
 \*mexicàna *Moc. et Sesse*  
 \*Pyracantha *Pers.*  
 Photinia *Lind.*  
 \*serrulàta *Lind.*  
 \*arbutifòlia *Lind.*  
 \*integrifòlia *Lind.*  
 Raphiòlepis *Dec.*  
 \*índica *Dec.*  
 \*salicifòlia *Lind.*  
 \*rùbra *Lind.*  
 Eriobótrya *Lind.*  
 \*japónica *Lind.*  
 Cotoneáster *Med.*  
 \*rotundifòlia *Wall.*  
 \*microphýlla *Wall.*  
 Cydònia *Tourn.*  
 \*japónica *Pers.*  
 \*flore-álbo *Hort. Lign.*  
 Margyricápus *R. et Pav.*  
 setósus *R. et Pav.*

Ancístrum *Kth.*  
 argénteum *Fl. Per.*  
 Potèrium *L.*  
 spinòsum *L.*  
 caudàtum *Ait.*

*Calycanthàcea Lind.*

Calycánthus *Lind.*  
 \*flóridus *L.*  
 \*lævigátus *Willd.*  
 Chimonánthus *Lind.*  
 \*frágrans *Lind.*  
 \*grandiflòra *Lind.*  
 \*minor *Hort.*

These beautiful and fragrant plants ought to entwine their branches with those of the rose against every cottage in Great Britain.

*Granatàcea D. Don.*

Púnica *Tourn.*  
 \*Grànatum *L.*  
 \*flore-plèno *Lind.*  
 \*albescens *Dec.*  
 \*flore-plèno *Dec.*  
 \*flávum *Hort. Lig.*  
 \*nàna *L.*

*Onagràcea Lindl.*

Fúchsia *L.*  
 arboréscens *Sims*

And all the other species and varieties in cultivation. Amongst these \**F. díscolor B. R.* (better known as the Port Famine fuchsia) is particularly deserving of notice, as being very hardy, and one of the most beautiful of the old sorts.

*Lythràcea Lindl.*

Lýthrum *L.*  
 alátum *B. M.*  
 Heimia *Dec.*  
 \*salicifòlia *Dec.*  
 myrtifòlia *Otto.*  
 Låwsònia *Dec.*  
 inérmis *Willd.*  
 Lagerstrœmia *L.*  
 índica *L.*

*Philadelphàcea Arb Brit.*  
 Decumària *L.*  
 \*bàrbara *Ph.*

*Myrtàcea Dec. Prod.*  
 Cálythrix *Dec.*  
 glàbra *B. R.*  
 Tristània *Br.*  
 nerifòlia *R. Br.*  
 laúrina *Dec.*  
 Beaufórtia *R. Br.*  
 decussàta *R. Br.*  
 Melaleùca *R. Br.*  
 paludòsa *Dec.*  
 armillàris *Dec.*  
 thymifòlia *Sm.*  
 pulchélla *Br.*  
 Eridésmia *Br.*  
 tetragòna *Br.*  
 Eucalýptus *Br.*  
 longifòlia *Smith*  
 \*robùsta *Sm.*  
 \*speciòsa *Hort.*  
 \*pulverulénta *B. M.*  
 \*cordàta *Lab.*  
 \*connàta *Dum.*  
 tuberculàta *Br. ?*

Many others of this fine genus, containing above 60 species. The above will stand the average of winters with very slight protection.

Angóphora *Cav.*  
 lanceolàta *Cav.*  
 Callistèmon *Dec.*  
 salígnus *Dec.*  
 scàber *B. Cab.*  
 lanceolátus *Dec.*  
 lophánthus *Sw.*  
 Metrosidèros *Dec.*  
 capitátus *Dec.*  
 corifólius *Vent.*  
 flexuòsus *Willd.*  
 flóridus *Dec.*  
 Leptosérmum *Dec.*  
 \*seríceum *Lab.*  
 laníferum *B. M.*  
 \*scopàrium *Dec.*  
 \*squarròsum *Gært.*  
 junipérinum *Vent.*  
 Fabrícia *Dec.*  
 \*myrtifòlia *Dec.*  
 \*lævigàta *Dec.*  
 \*seríceà *Dec.*  
 Bæ'ckia *Dec.*  
 \*virgàta *B. M.*

This and the two preceding genera I have known three winters in succession to stand without the

- least protection in the open ground.
- Mýrtus* L.  
\**communis* L.  
And all its varieties.  
*tomentosa* B. M.  
This is a beautiful plant, but would require the warmest place on a conservatory wall, and extra care.
- Eugènia* L. ?  
*myrtifolia* B. R.
- Cucurbitaceæ* Dec. Prod.  
Many of the more curious sorts, if planted annually, would give an *éclat* to the scene, and likewise continue the natural chain.
- Passifloraceæ* Hort. Lig.  
*Passiflora* L.  
\**cærulea* L.  
\**Colvilli* Sw.  
*incarnata* Lawr. *Pass.*  
*glabra* Wendl.  
*Tacsonia* Juss.  
*pinnatistipula* Juss.
- Loasaceæ.  
*Blumenbachia* Dec.  
*insignis* Dec.  
Although an annual,
- if sown against a warm wall, it will continue to grow from self-sown seeds for years.
- Scyphanthus* Sw.  
*élegans* Sw.  
*Loasa* Dec.  
Several varieties annually.
- Portulacæa* Dec. Prod.  
*Pharnaceum* L.  
*incanum* L.  
*Paronychiaceæ.*
- Herniaria* Fl. Brit.  
\**polygonoides* Dec.  
*Polycarpæa* Dec.  
*latifolia* Dec.  
*Smithii* Dec.  
*Mollia* Spreng. Syst.  
*gnaphalodes* Sp. Syst.  
*Crassulaceæ* Dec.
- Crassula* Haw.  
*ramosa* Haw.  
*tetragona* Haw.  
*scabra* Haw.  
*lycopodioides* Dec.  
*ericoides* Haw.  
*perifossa* Dec.  
*perforata* Dec.  
*marginalis* Dec.  
And several others.
- Purgosea* Haw.  
*linguæfolia* Haw.
- pertusa* Haw.  
And several others.
- Globulea* Dec.  
*cultrata* Dec.  
*lingua* Dec.  
*mesembryanthoides* D  
And several others.
- Ròchea* Dec.  
*falcata* Dec.  
*perfoliata* Dec.  
*albiflora* Dec.  
*Kalosánthes* Haw.  
*coccinea* Haw.  
*versicolor* Haw.  
*cymosa* Haw.  
And several others.
- Cotylèdon*  
*jasminiflora* Dec.  
*hemisphærica* Dec.  
And several others.
- Echeveria* Dec.  
*cæspitosa* Dec.  
*Sèdum* L. many sorts.  
*Sempervivum* L.  
*tortuosum* Dec.  
*villòsum* Haw.  
*ciliatum* Haw.  
*arborescens* Haw.  
*dodranta* Dec.  
And others, except *tabulæformis*, which is very tender.
- Mesembryaceæ.*  
*Mesembryanthemum* L. §

§ Of this splendid genus botanists enumerate nearly 350 species; but I have never been able to collect together above 320 of them out of British collections, nor do I think there exist more at present in Britain. As plants of ornament they have been greatly overlooked by cultivators, especially considering how hardy they are: for out of the above number above 200 will endure the climate of Britain with the thermometer at 24° Fahr., and many a much greater degree of cold, especially the sheathing-stemmed kinds. In planting the species against a conservative wall, such as that at Chatsworth, there ought to be a ridge of rockwork raised against the wall, composed of old bricks, clinkers, flints, shells, and any curious stones to be found in the neighbourhood, the whole to be intermixed with a soil composed of peat earth, white sand, common garden earth, and lime rubbish, and thoroughly drained, as much of the success of keeping them alive during the winter will depend upon this; for, although there is no family of plants luxuriates more when well supplied with water in summer, yet there is great danger with many of them from injudicious watering in winter, more especially when planted out. The same remarks will hold good with the preceding order *Crassulaceæ*, and the following one *Cactaceæ*. I would (were it possible in building such a wall) have the spaces allotted for these genera interspersed with cavities formed of rough blocks of lava, madrepores, millepores, and shells of various species, such as Neptune's chair, *Strobilus gigas*, ammonites, &c., into which many of

- Cactàcæ* Hort. Lig.  
*Cereus* Dec.  
*flagelliformis* Dec.  
*Humboldtii* Pffr.  
 And two or three others belonging to the *Reptantia* sect.  
*Opuntia* Dec.  
*polyantha* Pffr.  
*vulgaris* Dec.  
*amyclæa* Dec.  
 And several others.  
*Nitrariacæ* Lindl.  
*Nitraria*.  
 \**tridentata* Desf.  
*Grossulacæ* Dec.  
*Ribes* L.  
 \**speciosum* Pursh  
 \**sanguineum* Pursh  
 \**aureum* Pursh  
 I have added these, although hardy, as representations of the order, and as being very beautiful.  
*Escalloniacæ* Hort. Lig.  
*Escallonia* Mutis  
 \**rubra* Pers.  
 \**montevidensis* Dec.  
 \**floribunda* Kth.  
 \**resinosa* Pers.  
 \**pulverulenta* Pers.  
 \**glandulosa* Hort. Lig.  
 \**illinita* Hort. Lig.  
*Saxifragacæ*.  
*Hydrangea* L.  
 \**quercifolia* Willd.  
 \**hortensis* Sieb.  
*Cunoniacæ* Brown.  
*Cunonia* L.  
*capensis* L.  
*Callioma* Andr.  
*serratifolia* Andr.  
*Baiera* Sal.  
*rubiaefolia* Sal.
- Umbellacæ* Lindl. ?  
*Bupleurum* Tourn.  
 \**frutescens* L.  
*spinosum* Sch.  
*Araliacæ* Jus. Gen. Pl.  
*Cussonia* Willd.  
*thyrsiflora* W.  
*spicata* W.  
 These I have known to resist 8° of frost without injury.  
*Aralia* L.  
 \**spinosa*. L.  
 I have seen this plant 14 ft. high, and 2 in. to 3 in. diameter, against a wall, where it had stood for several years.  
*Hedera* Swartz  
*fragrans* Don Prod.  
 I do not know if this plant is yet in Britain.  
*Caprifoliacæ* Juss.  
*Cornus* L.  
 \**florida* L.  
*Benthamia* fragifera Lin.  
*Viburnum* L.  
 \**odoratissimum* B. R.  
 \**rugosum* B. R.  
 Two fine shrubs.  
*Lonicera* Desf.  
 \**confusa* Loud.  
 \**longiflora* Dec.  
 \**japonica* Thunb.  
 These are very fine fragrant plants, especially *longiflora*.  
*Rubiacæ* Juss.  
*Luculia* Sw.  
*gratissima* Sw.  
 One of the most beautiful plants of the Hort. Brit. when properly cultivated.
- Gardènia* R. et. S.  
*florida* Sh. Syst.  
*radicans* Sh. Syst.  
 Although requiring the moist heat of a dung-bed to flower them well, they will nevertheless stand our mildest winters unprotected, especially *florida*.  
*Burchellia* B. R.  
*capensis* B. R., will stand 5°.  
*Pinckneya* Michx.  
 \**pubens* Michx.  
*Manettia* R. et Sch.  
*glabra* Cham.  
 This fine creeper (although generally kept in the stove) will stand several degrees of frost without suffering. It has been frozen here, this season, on a rafter in the greenhouse where the thermom. marked 28° Fahr., without injury.  
*Bouvardia* Kth.  
*Jacquini* Kth.  
*triphylla* Sch.  
 These two plants are often confounded in gardens with one another.  
*Nauclea* L. ?  
*Adina* Smith  
*Mitchella* L.  
 \**repens* L.  
*Serissa* Com.  
*scetida* Com.  
*Rubia* L.  
 \**fruticosa* H. K.  
*angustifolia* Lam.  
*lucida* Flor. Græc.  
*Galium* L.  
*fruticosum* Sch.

them might be planted with great success, thus adding to their grotesque and ornamental character : and, I am sure, from my knowledge of succulent plants, that there are none in the whole circle of Flora which would better repay the care of the cultivator, not only in summer, but during the dark winter months, by the *bizarrierie* of their outlines and the beauty of their flowers. Whoever has seen the splendid collections of these plants on the Continent, and the once famous collection at Clermont (of which I was the parent and the nurse), will readily agree with my opinions on the subject.

- Dipsacæ* Juss.
- Scabiösa L.  
 attenuata L.  
 \*africana Herm. Pac.  
 crética (?).  
 altissima Jacq.
- Compösitæ* Adanson.
- Hieracium L.  
 fruticosum H. K.  
 Prenanthes L.  
 pinnata Willd.  
 arborea Willd.  
 spinosa  
 Sonchus L.  
 fruticosus L. non Jacq.  
 radicatus Sch.  
 pinnatus Sch.  
 Onoseris Dec.  
 mexicana Kth.  
 Mutisia L.  
 speciosa B. M.  
 \*ilicifolia Hort.
- This last will bear  
 8° of frost.
- Syncarpha Dec.  
 gnaphalodes Dec.  
 Carthamus Willd.  
 arborescens Willd.  
 salicifolius Willd.  
 Stæhelinia Willd.  
 arborescens Willd.  
 Centaurea L.  
 hyssopifolia Barrel.  
 argentea Willd.  
 C'dera  
 prolifera B. M.  
 Baccharis R. Br.  
 mollis Kth.  
 Conyza L.  
 candida L.  
 geminiflora L.  
 Gnaphalium L.  
 ericoides B. M.  
 carneum.  
 orientale Don  
 Aster L.  
 tomentosus Willd.  
 \*argophyllus B. M.  
 Chrysocoma L.  
 Comaurea L.  
 scabra Willd.  
 Dönia B. R.  
 glutinosa B. R.  
 Grindelia Willd.  
 pulchella Schul.  
 angustifolia B. R.  
 Neja Don  
 gracilis D. Don
- Agératum Willd.  
 caelestinum B. M.  
 Kleinia Willd.  
 suffruticosa W.  
 Cacalia L.  
 scandens Willd.  
 Senecio L.  
 venustus B. Reg.  
 ilicifolius Willd.  
 lilacinus B. M. ?  
 Cineraria L.  
 aurita B. M.  
 lactea Willd.  
 cruenta B. M.  
 populifolia H. K.  
 \*maritima L.
- And many other  
 beautiful varieties.
- Agathæa Cas.  
 caelestis Cas.  
 Othonna L.  
 flabellifolia B. C.  
 pectinata B. M.  
 frutescens Willd.  
 Relbaniia Willd.  
 squarrosa Willd.  
 pungens Willd.  
 Verbesina B. M.  
 alata B. M.  
 Bupthalmum L.  
 frutescens Pursh  
 sericeum B. M.  
 Wedelia Kth.  
 aurea D. Don  
 Gazania H. K.  
 \*uniflora B. M.  
 rigens B. B.  
 Sphenogyne H. K.  
 pilifera B. R.  
 Arctotis H. K.  
 tricolor B. R.  
 grandiflora Jacq.  
 \*speciosa B. M.  
 arborescens Willd.  
 glutinosa B. M.  
 Calendula Willd.  
 denticulata Schult.  
 \*fruticosa Willd.  
 arborescens Jacq.  
 Podanthus Lagas.  
 gratus D. Don  
 Santolina L.  
 pinnata.  
 Athanasia Willd.  
 lanuginosa Cav.  
 pinnata Lam.  
 Artemisia L.  
 valentina Willd.  
 Pénzia Thun.
- flabelliformis Willd.  
 Eriocephalus Willd.  
 frutescens H. K.  
 Hippia Desf.  
 frutescens Desf.  
 Anthemis L.  
 triflora Willd.  
 Ferdinandia Lag.  
 augusta Lag.  
 integrifolia D. Don  
 Chrysanthemum L.  
 \*sinense.
- Many fine varieties.
- Pyræthrum L.  
 frutescens Willd.
- Lobeliacæ* Juss.
- Lobelia Flor. Brit.  
 linearis Schult.  
 gigantea B. M.  
 Isotoma B. R.  
 axillaris B. R.
- Stylidæacæ*.
- Stylidium Brown  
 laricifolium B. R.  
 fruticosum Br.
- Goodeniæacæ*.
- Goodenia Br.  
 grandiflora Br.  
 Lechenaultia Br.  
 formosa B. M.  
 oblata B. M.
- These plants are  
 very impatient of  
 damp, but will bear  
 6° frost.
- Campanulæacæ* Juss.
- Campánula L.  
 aurea B. R., rare in  
 England.  
 \*Prismatocarpus B. M.  
 Roëlla B. M.  
 ciliata B. M.  
 pedunculata Sch.  
 Impatient of damp.
- Eriacæ* Hort. Lig.
- Erica L.  
 \*arborea L.  
 \*australis L.  
 acuminata L.  
 ventricosa B. M.  
 actæa Lk.  
 \*umbellata H. K.
- Many others will  
 bear from 8° to 12°  
 frost without injury;  
 but, as I intend send-  
 ing you a paper on

- Erica*, I will not make any further remarks.
- Cyrilla* L.  
\**racemiflora* L.  
*Lyonia* Nutt.  
*ferruginea* Nutt.  
*rigida* Nutt.  
*Andrömeda* L.  
\**ovalifolia* Don  
*buxifolia* B. M.  
*Enkiänthus* B. M.  
*quinqueforus* B. R.  
*A'rbutus* L.  
†*Andrächne* L.  
\**canariensis* Lam.  
*ferruginea* L.  
*Cléthra* L.  
*arborea* H. K.  
*ferruginea* R. et Pav.  
*Rhododéndron* L.  
*setosum* D. Don  
*lappönicum* Wahl.  
*arboreum* Sm.  
†*campanulatum* Don  
*cinnamömeum* Wall.  
\**indicum*.  
\**phöniceum* Don  
*variegatum* Blum.  
\**album*.  
*sinense* Sw.
- Epacridaceæ* Hort. Lig.  
*Cosmèlia* Br.  
*rùbra* Br.  
*E'pacris* Br.  
*grandiflora* B. M.  
*impressa* Sw.
- And all the other species of this beautiful genus, they will resist 10° frost without injury.
- Acrotüche* Br.  
*cordata* Br.  
*ovalifolia* Br.  
*Leucopögon* Br.  
*Ríchei* Lab.  
*juniperinus* Lodd.  
*Styphèlia* Br.  
*tubiflora* Smith  
*viridiflora* Sw.
- Penæaceæ* Sw.  
*Penæ'a* Schult.
- mucronata* Sch.  
*squamösa* Sch.
- Symplocaceæ* Hort. Lig.  
*Sýmplocos* L'Her.  
*tinctöria* W.  
*sínica* Ker  
*Ebenaceæ* Brown.  
*Diospýros* L.  
\**chinensis* Blume§  
*Royèna* W.  
*lúcida* Lam.  
*Oleaceæ* Arb. Brit.  
*Ligústrum* Tourn.  
\**spicatum* Hamilt.  
\**lucidum* Ail.  
\**japönicum* Thunb.  
*O'lea* L.  
\**europæ'a* L.  
\**americana* L.
- This has stood here two winters without the slightest protection, the thermometer stood at 0° Fahr. this winter (on the 8th of January).  
*frágans* Thunb.  
Stood last winter.  
*capensis* L.  
*excélsa* H. K.  
*undulata* Sch.  
*glandulifera* Hort. P.  
*láncea* Sch.  
*exasperata* Hort. Par.  
*Notelæ'a* Br.  
*longifolia* Br.
- Jasminaceæ* Arb. Brit.  
*Jasminum* Forsk.  
\**heterophýllum* Roxb.  
†*revolutum* Ker  
*azóricum* Vahl  
*pubigerum* Don  
*volubile* Jacq.
- Apocynaceæ* Hort. Lig.  
*Gelsémium* Juss.  
*sempervirens* Pers.  
*Nèrium* L.  
*Oleánder* L.
- Asclepiadaceæ* Arb. Brit.  
*Períploca* L.
- \**panicæfölia* Cav.  
*Physiänthus*  
*álbens* Hort.  
*Stapèlia* L.  
\**Gussoniana* Haw.  
This curious little plant is quite hardy, if placed in a crevice of a wall.
- Gentianaceæ*.  
*Chirönia* L.  
*jasminöides* B. R.  
*linöides* B. M.  
*frutescens* B. M.  
*trinervis* B. R. ?  
*Bignoniaceæ* Br.  
*Bignönia* Tourn.  
\**capreolata* B. M.  
*Técoma* Juss.  
\**grandiflora* Swt.  
*austrális* Br.  
*capensis* B. R.  
*Calámpelis* D. Don  
\**scábra* Sw.  
*Cobæaceæ* D. Don.  
*Cobæ'a* Cav.  
*scándens* Cav.  
*stipularis* Hort.
- I have found *C. scándens* endure severe frost; and, when killed down, to spring up again from the root, when protected with a little short litter.
- Polemoniaceæ* D. Don.  
*Hoitzia* Juss.  
*coccinea* Kth.  
*mexicana* (?)  
*cærúlea* Kth.
- The first species is a splendid plant, of a vivid scarlet colour, and produces its flowers very freely: this is not the case with *mexicana*, a robust grower but shy flowerer: *cærúlea* is rather delicate and shy.

§ Although the roots of this plant will resist the severest frost, yet the branches will not bear our climate without protection, owing to the shortness of our summers, and the want of autumnal warmth to ripen the shoots; consequently, like all such plants, it requires a dry subsoil and airy situation.



- Convolvulææ* Br.  
*Convólulus* L.  
*Cneórum* B. M.  
*flóridus* Jacq.  
*lineàris* Hort.  
*suffruticòsus* Desf.  
*canariénsis* B. M.  
 \**Quámoclit* Brong.  
*bicolor* Brong. §
- Boraginææ* Hort. Lig.  
*Lithospérmum* L.  
*fruticòsum* L.  
*hispidulum* Schul.  
*rosmarinifólium* Hort.  
*E'chium*  
*gigantèum* L.  
*Tournefórtia* Schult.  
 \**heliotropiòides* Hort.  
*Solanææ* Arb. Brit.  
*Pétinia* of sorts.  
*Nicotiàna*.  
 \**gláuca* B. M.  
*Brugmànsia* Pers.  
*sanguínea* R. et P.  
*suavèolens*.  
*Lýcium* L.  
*boerhaaviæfólium* L.  
*Véstia* W.  
 \**lyciòides* W.  
*A'tropa* L.  
*frutescens* Sch.  
*Solànum* L.  
*laciniàtum* B. M.  
 \**crispum* Sch.  
*bonariénsis* L.  
*Céstrum* L.  
 \**venenàtum* Sch.  
 \**acuminàtum* Sw.  
 This last will endure the generality of winters.
- Scrophulariææ* Arb. B.  
*Búddlea* L.  
 \**globòsa* L.  
*Hallèria* L.  
*lúcida* B. M.  
*Maurándya* B. M.  
*semperflòrens* B. M.  
*Barclayàna* B. M.  
*antirrhiniflòra* B. R.  
*Lophospérmum* D. Don
- scándens* Don  
*cærùlea* Hort.  
*Digitàlis* L.  
*canariénsis* B. R.  
*Díplacus* (?)  
 \**glutinòsus* (?)  
*puníceus* B. R.  
*Manùlea* Schult.  
 \**viscòsa* Schult.  
*pedunculàta* Pers.  
*Calceolària* L.  
 \**rugòsa* R. et P.  
*thyrsiflòra* B. M.  
 And nearly all the shrubby kinds.  
*Verónica* L.  
 \**decussàta* H. et K.  
*perfoliàta* B. M.  
*Labiææ* Arb. Brit.  
*Oríganum* L.  
*Tournefórtii* Fl. Gr.  
*Dictámnus* B. M.  
*Westrìngia* Schult.  
*rosmarinifórmis* Smith.  
*longifolia* Br.  
*Teucrium* L.  
 \**fruticans* L.  
*règium* Pluk.  
 \**alpèstre* Fl. Gr.  
*montànum* Fl. Gr.  
 \**Pòlium* L.  
*lusitánicum* Sch.  
*aúreum* Cav.  
*flavescens* Barrel.  
*heterophýlla* Cav.  
*Màrum* L.  
*flàvum* Fl. Gr.  
*massiliénsis* Fl. Fran.  
*Leonòtis* B. M.  
 \**Leonùrus* B. M.  
 This fine plant deserves general cultivation. It is very nearly hardy.  
*Phlòmis* L.  
 \**fruticòsa* L.  
*crética* Sch. Syst.  
 \**itálica* Sch.  
*armeniaca* Sch.  
*salviæfòlia* Pers.  
*Beringèria* B. R.  
 Ps.-*Dictámnus* B. R.
- Sphácele* B. R.  
*campanulàta* B. R.  
*Stàchys* L.  
 \**spinòsa* L.  
*stenophýlla* Sch.  
*coccínea* B. M.  
*Sideritis* L.  
*canariénsis* Jacq.  
 \**càndicans* Hort. Par.  
*brùtia* Tenore  
*leucántha* W.  
*Lavándula* L.  
 \**dentàta* L.  
*formòsa* Link  
*Dracocéphalum* L.  
 \**canariénsis* L.  
*Sálvia* L.  
*aúrea* B. M.  
 \**chamædryòides* B. M.  
*fùlgens* Swt.  
 \**Gràhami* Benth.  
*odoràta* Jacq.  
*crassifòlia* Sch.  
*Pràsium* L.  
*màjus* L.  
*minus*  
*Plectrànthus* L'Her.  
*fruticòsus* L'Her.  
*coloràtus* Dec.  
*Prostanthèra* Br.  
*lasiánthos* B. R.  
*violàcea* B. R.
- Selaginææ*.  
*Selàgo* Choisy  
*spicàta* Link  
*fruticòsa* Choisy.  
*Grillièsi* Hort.  
*Verbenææ* Br.  
*Vitex* L.  
 \**A'gnus-cástus* W.  
 \**incisa* B. M.  
 \**arbòrea* Hort. Paris.  
*Volkamèria*  
*inérmissis* L.  
*Lantàna*  
*Sellòi* B. M.  
*Spielmannia* B. M.  
*africana* B. M.  
*Aloysia* Pers. Syn.  
 \**citriodòra* Pers.  
*Verbèna* L.  
*Aublètia* B. M.

§ This is a splendid plant ; and, although too tender to stand during winter without the protection of at least a warm greenhouse, it, nevertheless, would amply repay the trouble of annual transplantation by the splendour of its flowers, which it produces in profusion.

- Melindres* B. R.  
*niveana Hort.*  
 And many other splendid varieties, as taste may dictate.  
*Myopórina* Brown.  
*Myóporum* Br.  
*tuberculátum* Br.  
*Stenochilus* Br.  
*viscósus* Grah.  
*Acanthácea* Brown.  
*Thunbérgia alata* B. M.  
 Planted annually, it will ripen seed abundantly.  
*Justícia Ahhátoda* L.  
*Primulácea* Brown.  
*Prímula* L.  
 \**Palinuri* Sw. F. G.  
*Anagállis* L.  
*fruticósa* B. M.  
 Monélli B. M.  
*Globulariácea* Hort. Lig.  
*Globulària* L.  
*longifólia* L.  
*Plumbaginácea* Hort. Lig.  
*Státice* L.  
*monopétala* Ræm.  
*suffruticósa* L.  
 I am not aware that either of these fine plants is yet in Britain. *mucronata* L'Her. Not a herbaceous species, properly speaking; when planted out, it will attain the height of several feet, and will continue growing throughout the year.
- Plantaginæa* Juss.  
*Plantágo* L.  
*cynops* Jacq.  
*áfra* Moris.  
*Chenopodiácea* Arb. Brit.  
*Anábasis* L.  
*aphýlla* Ræm.  
*Salsóla* L.  
*brevifólia* Hort. Par.  
*oppositifólia* Hort. Par.  
*prostráta* Jacq.  
*Chenopódium* L.  
*suffruticósum* Ræm.  
*Atriplex* L.  
*gláucum* W.  
*coriáceum* Ræm.  
*Bósea* L.  
*Yervamòra* L.  
*Salicórnia* L.  
*arábica* Moris.  
*Camphorósmá* L.  
*monséliacum* Willd.  
*Polygonácea* Hort. Lig.  
*Brunnáchia* Gært. n.  
 \**cirrhósa* Gært. §  
*Polygonum* L.  
*adnátum* Hort.  
*herniarióides* Sch.  
*élegans* Sch. non H. K.  
*tortuósum* Dec.  
*frutéscentis* B. R.  
*Atrapháxis* L.  
 \**spinósa* L.  
 \**unduláta* L. (?)  
*Lawràcea*.  
*Laúrus* Plin.  
*Catesbæi* Pers.  
 \**carolinénsis* Michx.  
*fœtens* W., fine shrub.  
 \**Mýrrha* Lour.
- índica* L., a fine shrub for hot wall.  
*Cámphora* L.  
 I have seen a tree of this somewhere, against a wall, that had stood for two or three years, as marked on a specimen in my herbarium; but I have neglected to note the place, and at present forget where.  
*Proteácea* Brown.  
*Grevillea*.  
*punicea* B. R.  
 \**rosmarinifólia* Swt.  
 This has stood out here in the open border unprotected, with the thermometer at 0.  
 \**juniépina* B. C.  
 And many other species. I have tried about 12 species of this genus out, and am convinced from the result that nearly all the species will live and flourish against a conservative wall.  
*Bánsia* Br.  
*spiuulosa* Andr.  
 ? \**littorális* Br.  
*cómpar* L. T.  
*oblongifólia* Cav.  
*serráta* And. Rep. ||  
*Thymelácea* Arb. Brit.  
*Dáphne* L.  
*odóra* Thunb.

§ This rare climber was killed to the ground in 1838, but sprang up again strong from the roots, in the Jardin des Plantes; thus giving a kind of natural evidence to prove how much we ought to guard against the direct rays of the sun striking against the congealed trunks or stems of plants not truly hardy. Had these roots not been surrounded by an opaque medium, thus preventing the too sudden thawing, and consequent disruption of the vessels exposed to the varying influence, their total destruction, I have no doubt, would have been the result. Although, on the other hand, I am aware this will not always be the case, for there are a few plants whose roots seem to defy both sun and frost to kill them, whilst their stems are comparatively tender. But I think it will generally be allowed, and, in fact, the late severe winter has put it almost beyond dispute, that the less we expose half-hardy plants to the influence of the sun, the more likely we are to succeed in inuring them to the open air.

|| These will all stand against a wall if well protected, as will nearly all the

- \*hybrida Sw.  
 \*collina B. M.  
 \*sericea Vahl  
 \*neapolitana Lodd.
- The last 4 species, although they will endure the generality of our winters without protection, are apt to suffer should the thermometer fall below 10° Fahr.
- Gnidia L.  
 \*imbribis B. M.  
 \*simplex B. M.
- These two are often confounded together in gardens.
- sericea Willd. Wants more protection than the two preceding.
- Dais L.  
 cotinifolia B. M.
- A beautiful plant, which deserves to be in every collection.
- Pimelæa Br.  
 decussata Sw.  
 ligustrina Lab.  
 hypericifolia Hort.
- And perhaps all the others, but I have not had the opportunity of trying; the above will bear 6° frost.
- Elæagnaceæ Arb. Brit.  
 Elæagnus Tourn.  
 \*arborea Roxb.  
 spinosa L.
- Aristolochiaceæ Arb. Brit.  
 Aristolochia L.  
 \*sempervirens L.  
 \*rotunda Hort. Paris.
- Euphorbiaceæ Juss.  
 Adèlia  
 acuminata Hort.  
 Euphorbia  
 dendroides Willd  
 spinosa Wats. Dend.  
 fruticosà L.  
 imbricata Willd.  
 veneta L.
- And several others of this heterogeneous family. Nature seems to have mixed up in this the forms of all other genera; and to have embellished it at the same time with some of the most conspicuous as well as inconspicuous of flowers.
- Urticææ Juss.  
 Urtica L.  
 arborea L'Herit.  
 Cèltis  
 orientalis Hort.  
 Betulæcæ Hort. Lig.  
 Philipodendron Hort. P.  
 regia Hort. Paris.  
 (syn. Bétula bélla)  
 Cupulifera Kunth.  
 Quercus L.  
 †xalapensis Hort. Soc.
- \*lanuginosa Dec.  
 Casuaraceæ Hort. Lig.  
 Casuarina Hort. Kew.  
 \*stricta Hort. Kew.
- Male and female.  
 This must not be confounded with a species from Gambia, which it resembles very much, and which is perhaps the equisetifolia Hort. non Willd.
- Taxaceæ Hort. Lig.  
 Podocarpus L'Her.  
 \*elongatus L'Her.
- Pinaceæ Hort. Lig.  
 Pinus L.  
 longifolia Roxb.  
 \*canariensis C. Smith  
 \*insignis Doug.  
 Cunninghamia R. Br.  
 \*sinensis.  
 Thùja L.  
 chilensis Lamb.  
 Juniperus.  
 barbadensis L. (bermudiàna Hort. Par.)  
 Smilacææ Br.  
 Smilax L.  
 \*excelsa Sch.  
 \*hastata Sch.  
 Ophiopogon B. M.  
 spicatus B. R.  
 Aspàragus L.  
 \*scandens.  
 Xanthorrhœa Brown  
 mèdia Br.

Hovea purpurea has stood the winter with the thermometer at zero, with only a little fern thrown over it, in the open border, though the shoots are killed back half-way. Grevillea rosmarinifolia has proved itself here a hardy evergreen, at least as hardy as a common laurel.

Since writing the above list of Kennèdya, I find K. inophýlla (Zíchyá) the hardiest of this division, next coccinea, then paunosa; tricolor, glabrata, and another I am not certain of, are very tender. The hardenbergias are the hardiest, especially Hugèli. Kennèdya Stirlingii is rather tender, as are also Marryattæ and angustifolia; spléndens appears to be the hardiest of all.

---

species belonging to the genus, except perhaps it may be speciosa, which appears to me the tenderest. Although I have only enumerated the above in Protæcææ, yet I am convinced, from my knowledge of the order, that the greater number of the species would thrive against such a wall as the Chatsworth one. I see, from my herbarium, and notes taken of above 200 species of this order, that I have marked nearly 100 of them as half-hardy, or such as will stand, when well protected, against a wall.

ART. II. *Theory of M. Edward Lucas's Experiments on the Effect of Charcoal on Vegetation.* By Dr. A. BUCHNER, Sen. (Translated from the "Garten Zeitung" for the "Gardener's Magazine," by M. L.)

THE numerous experiments and observations mentioned in this treatise appear to me to be very important contributions, not only to vegetable physiology and dietetics, but also to the founding of a vegetable therapeutic system, which, if I am not mistaken, has not hitherto been taken into consideration. I take leave, therefore, to make a small addition in a theoretical point of view, in order to introduce a clear scientific notion of the effects of charcoal on vegetable life. These effects are founded, undoubtedly, on several causes, of which the following appear to me the most important.

1. *Absorption of Light, and Generation of Heat.* It is well known that bodies receive the light of the sun the more perfectly, the darker, duller, and looser they are, and that the consequent development of heat is in proportion to this absorption of light; hence, a black light soil is, under the same circumstances and relations, much more favourable to vegetation than a light-coloured, grey, heavy earth. Heavy clayey soil, with a deficiency of humus, is less suitable to vegetation, inasmuch as it soon loses its porosity through rain and snow, and assumes a smooth surface, by which it is prevented from absorbing air and light and generating heat. Hence agriculturists justly name these clayey soils, which are deficient in humus, cold soils. As charcoal dust is one of the darkest, dullest, and most porous of bodies, it must, on account of its peculiar capacity of receiving the sun's light and changing it into heat, be particularly favourable to vegetable life. M. Lucas, in his experiments next summer, will, no doubt, not omit making comparative thermometrical experiments.

2. *Absorption of Atmospherical Air.* Among all porous bodies that have the capacity of absorbing gases and vapours, charcoal has been proved by numerous experiments to hold the first rank. If, therefore, clayey soil, deficient in humus, is in general less suitable to the growth of plants than rich loose garden mould, the reason lies, not only in the latter receiving more light and creating warmth, but also in its more readily condensing, by its greater porosity, the constituent parts of the atmospherical air, and consequently supplying oxygen, nitrogen, and carbonic acid gas for the nourishment of the spongioles. We come here to a very important point, the nourishment of plants, which I cannot slightly pass over in elucidating the theory of the effects of charcoal in this respect. Modern vegetable physiologists are, for the most part, of opinion, that plants can receive no solid nourishment from the earth; that is, that every thing that they can assimilate (or digest) must be in a liquid and gaseous or vapoury state. If we, therefore, meet with siliceous earth, chalk, magnesia, oxide of iron, in short, such substances in plants as could only be received from the soil, we may always consider it certain that these sorts of matter can only be absorbed by the roots in proportion as they are in a fluid or dissolved state in the soil. These sorts of matter, and particularly the different organic salts which we find in the ashes of vegetables, are not actually to be considered sources of nourishment, but stimulants to assist in digesting, as salt and spice are to the higher animals and man; we also not unfrequently observe that a superfluity or mixture of certain inorganic substances in the soil, prejudicial to certain families and species of plants, is the cause of disease when this inorganised matter is in a dissolved state and capable of being absorbed by them.

If we analyse the nourishment of plants, we shall find it is only the constituent parts of air, water, and charcoal. The experiments of Boussingault on the origin of nitrogen in organic bodies show, 1st, that no plant exists without a proportion of nitrogen; and 2d, that, while men and animals receive the portion of nitrogen of their bodies not from the air by breathing, but from food by assimilation, plants on the contrary draw their supply of nitrogen, not

from manure or humus, but from the air. We come now to a very important point in the nourishment of plants, to which M. Payen has particularly called our attention in two treatises read before the Academy of Sciences at Paris, on the 8th and 14th of October, 1839: viz. that charcoal operates as a condenser, under the influence of water, on the constituent parts of the air, in the same manner as spongy platina on the elements of detonating gas; so that nitrogen and oxygen are dissolved, and, mixing with water, are absorbed by the spongioses, and carried to the cambium for assimilation. This property of condensing the air, and making it fit to be received by plants, does not exclusively belong to charcoal, for it is also more or less perceptible in other sorts of earth, chiefly in porous and pulverised bodies. We know that water, even when not distributed through charcoal or earth, absorbs some air, which becomes a watery fluid, and by heating is again expelled in the form of gas: but charcoal powder appears to possess this power in the highest degree; consequently, besides light and heat, is capable of carrying to the roots both air and water, i. e., nitrogen, hydrogen, and oxygen, in the greatest abundance.

3. *Decomposition of the Charcoal, and Formation of a nourishing Substance for Plants.* It is well known that manure, as such, does not nourish plants, and that, on the contrary, when it touches the roots it causes disease. We know that it is the constituent parts of the humus, i. e. the matter produced by decay, which nourish plants. This apparently takes place because the humus, with the cooperation of air and water, is continually forming oxide of charcoal, or carbonate and nitrogen, which, together with the saline particles, is absorbed and assimilated by the roots. For a long time it was generally believed that charcoal, as an inanimate body incapable of decay, contributed in no degree to the nourishment of plants, and that charcoal dust could only serve at most to make the earth looser and warmer. But M. Lucas found, from his experiments, that the charcoal in which plants grow by degrees undergoes decomposition, and at last becomes a sort of humus. This obviously takes place merely because the charcoal dust acts as humus, and, with the cooperation of water and air, continually gives out to the plants oxide of charcoal, or carbonate, together with the saline particles which are in the charcoal and remain in the ashes after burning. But, to prove this, some chemical experiments were necessary.

4. *Comparative Chemical Examination of Charcoal Dust.* The more perfectly to establish the theory of the effect of charcoal on vegetation, M. Lucas gave me for examination:—

1st. Ashes of fir charcoal in which no plants had grown.

2d. Ashes of fir charcoal in which plants had grown for half a year.\*

3d. A portion of charcoal dust which had been used for another purpose for two years.†

With these materials I made the following comparative experiments:—

Two drachms of them were reduced to fine powder, and digested in three ounces of distilled water for 24 hours. All the three quantities, filtered off from the charcoal, were uncoloured, and left the test paper unchanged. After the evaporation of the water, there remained only a very trifling yellowish residuum, of a saltish taste, which acted somewhat like an alkali, and, besides potash, contained also chlorine. No difference could be distinguished in this case between *a*, *b*, and *c*.

The portions of charcoal powder to which water had been applied were each separately digested in a sand-bath, with three ounces of water, to which a drachm of corrosive lie of potash was added. The liquid filtered from *a* was almost colourless, and was not the least muddy when saturated with muriatic acid. The liquid from *b* was brownish, and with muriatic acid yielded

\* This charcoal was used for most of the experiments.

† It was used to fill a bed, hence its impurity is easily accounted for.—  
*Lucas.*

a flocky dark brown precipitate of humic acid, which, being carefully collected and dried, weighed 0·27 grains. The liquid from *c* was of a darker colour, and, with muriatic acid, yielded 0·45 grains of humic acid.

Two drachms of each of the three portions of charcoal were reduced to ashes in the platina crucible. The ashes of *a* weighed 22 grains, and lost, by shaking with distilled water, one grain in weight. The ashes of *b* yielded only 9 grains of ashes, of which only half a grain was dissolved by the water. The ashes of *c*, on the contrary, weighed 33 grains; apparently because the charcoal powder, while in use for two years, had become fouled with garden mould; of these 33 grains of ashes, two grains were dissolved in water. The constituent parts of the three portions of ashes retained their qualities; so that in the dissolvable parts were found potash, chalk, carbonic acid, sulphuric acid, muriatic acid, and phosphate. The portion indissoluble in water contained chalk, magnesia, traces of oxide of iron, carbonate, sulphuric acid, phosphate and silicic acid.

If the objection be made, with respect to these three portions of charcoal, that they are not all from the same tree, and might therefore yield a different weight of ashes, we may, with probability, suppose that this natural difference is very inconsiderable, as the charcoal was all of fir wood from the neighbourhood of Munich, where limestone *débris* is the general understratum of the woods.

The result is quite decisive and undisputed, that diluted lie of potash scarcely ever dissolves any thing from fresh fir charcoal, and that, on the contrary, charcoal in which plants have grown, being partly changed into humus and this being drawn out by diluted lie of potash, amounted in the charcoal *b*, after six months' use, to 2·25, and in the charcoal *c*, after being two years in use, to 3·75 of 1000. By this it is also proved, that charcoal, under the influence of light, air, water, and vegetation, is gradually decomposed, by losing carbon; in the place of which hydrogen and oxygen predominate, and concur with the remains of carbonate to form humic acid.

No less interesting is the further comparison of the ashes of, I may say, the virgin charcoal *a* and the charcoal *b*, which had been used half a year for vegetation; in this instance *a* and *b* were in the proportion of 122 to 75 of ashes from 1000 of charcoal. Undoubtedly the dissoluble salts were, in proportion to the increasing decomposition of the charcoal, absorbed by the roots. That the greater weight of the ashes of *c* is not decisive has been already mentioned. To make very correct experiments of this sort, charcoal from the same tree should be burnt, equally reduced to powder, and, in planting in this powder, all impurities of garden mould, &c., carefully avoided, and watering the plants with rain-water attended to.

5. *Antiseptic Power of Charcoal.* In judging of the effects of charcoal on vegetation, its antiseptic properties are of great importance, for it has very little power of retaining water, and the little it retains is partly absorbed by the roots and partly evaporated. This property deserves the greatest attention of gardeners, in respect to recovering the health of plants the roots of which have become injured by being in a clayey soil, and too freely watered, or after continued rain, or being in contact with manure not sufficiently decomposed. They should be immediately transplanted into charcoal powder, as the most effectual method of cure.

6. *Literature.* In all scientific examinations, if they have any pretension to be well-founded, the greatest assistance may be procured from historical and literary researches. In this instance, however, it is very remarkable that all research in books which were at command was only a loss of time and trouble. In Dietrich's *Perfect Lexicon of Gardening and Botany*, with the Supplements, I looked in vain for the article "Charcoal," or "Charcoal Dust." I did not find more in Piever's *Encyclopedian Dictionary* or in Brockhaus's *Conversations Lexicon*. Leopold's *Economical Dictionary* contains only the following short passage: "Charcoal dust makes the earth light, and, when when mixed with sand, is very useful in a clayey soil."

In Krünitz's *Encyclopædia*, vol. 43., the article Charcoal is very comprehensive with respect to its preparation and technical application; but, with regard to agriculture and gardening, it is only mentioned (p. 225.) that "charcoal ashes serve to improve soils, and earth becomes very light by it." M. Lucas says he has looked for it in Loudon's *Encyclopædia of Gardening*, and found no further information there than in Krünitz.

From this I think I may conclude that all that has hitherto been known for the improvement of the soil by charcoal dust was only founded on casual observations, and that experiments made with a view to science on this very commonplace article, in the manner in which M. Lucas has pursued them with so much success, have not been hitherto made.

Munich, Feb. 29. 1840.

### ART. III. *On the Destruction of the Red Spider in Plant Structures.*

By ROBERT ERRINGTON.

A FEW facts are, I conceive, in the present state of horticulture, worth a volume of speculations; I therefore beg to forward you some statements of what has taken place here, which, although of an isolated character, will, I hope, be of some use. It is well known that the red spider is one of the greatest pests of the gardener; it is also well known that sulphur is destructive of that insect; yet, in spite of all this, it is more frequently found in gardens than it ought to be, considering that an antidote is at hand which is both economical in cost and use, and certain in its effects.

Few are disposed to use sulphur to the extent at which it may be used with impunity, through fear of its pernicious effects on vegetation if pushed to an extreme; which fear, however well founded in fact, is carried to an unnecessary extreme, as I am about to show. I have been in the habit of using sulphur for this purpose for some years, and, although I have houses in which most things are grown or forced which are peculiarly liable to that pest, yet it seldom (I might almost say never) makes its appearance.

As houses vary so much in their internal area, and as much depends on apportioning the quantity of sulphur to that area, I will assume a case which will be, I hope, a sufficient guide. For a house 30 ft. long, 16 ft. wide, 10 ft. high at back, and 6 ft. high at front, I have been in the habit of using at least 4 oz. It is heated by hot water, and the pipes are of 6-inch bore. One man with a watering-pot and syringe goes before the person who applies the sulphur, and who is provided with a dusting-brush and the sulphur in a bowl. The one syringes the pipes and the other applies the sulphur, until the pipes are fairly painted from one end to the other, except the part at which the fire enters for a few feet. A dull day is chosen for the purpose, and at the time of application I keep a rather brisk fire. If the house becomes insufferable to my own lungs I allow a little of the surplus fumes to escape at the back by ventilation, especially should the sun peep out suddenly; however, this is seldom necessary if the day be well selected.

By these means, repeated about three or four times in a year, I am, as I stated before, kept entirely free of this destructive pest.

Oulton Park Gardens, April 4. 1841.

### ART. IV. *On destroying the White and Brown Scale by the Application of hot Water.* By HENRY C. OGLE.

THE difficulty of destroying the white and brown scale, on plants of any description, is well known to cultivators. They may be partially destroyed on those plants having large leaves, by rubbing off and other means; but this would be an endless, and I may say a fruitless, task with plants having small

leaves. On my first entering my present situation, I found several plants nearly covered with white scale, and I had determined upon throwing them away; but, thinking I might as well try some experiments with them, either to kill or cure, I had recourse to hot water, being aware it was destructive to insects, and, until I had tried it, I doubted not, to evergreen plants also; but, in this I was wrong, as the sequel will show. I took for my experiment two plants of *Coronilla glauca* each 6 ft. high, one of *Coronilla glauca variegata* 3 ft. high, one *Nerium Oleander* 6 ft. high, and one *Corræa pulchella* 2 ft. high. I heated a copper of water to 180°, I laid these plants down by the side of it, and well washed each of them with water from the copper by means of the syringe; I turned them about several times that no part might escape the washing: the *Corræa* being the smallest plant, I plunged the head of it into the hot water and kept it there for the space of three or four seconds. I fully expected this would have killed both plants and insects; but in this I was also mistaken, for the plants are now alive, the leaves are slightly discoloured, but the wood is not at all injured. The insects, I believe, are all dead, many washed off with the hot water, and many more with cold water; and, as the plants grow, I have no doubt the whole of them will fall off, as I am persuaded that the water killed all those it touched. It will be useful to know the degree of heat water may be applied at to evergreen plants, as it will not only destroy the scale, but all other insects. It is frequently applied to wall trees, and with good effect, but I am not aware that it had been tried on evergreen plants. I am trying the effects of it on plants with more tender leaves, and in due time will send you the result.

In the mean time I hope some of your correspondents and readers will prosecute the enquiry, and ascertain what degree of heat different evergreen plants will bear with impunity.

*Rosehill Gardens, Sussex, Jan. 21. 1841.*

ART. V. *Further Information respecting the Flued Walls at Erskine House.* By G. SHIELLS, Gardener there.

AGREEABLY to your request, I now send you some further information respecting our flued walls, by the aid of which we have been enabled to obtain abundant crops of ripe fruit at an early season. But I shall confine my observations at present chiefly to the construction of the wall, and our mode of protecting the trees and fruit.

The flues are not plastered within. I have tried it with lime mixed with cow-dung, but I do not approve of it; lime being a non-conductor. It suits, however, for the under flues of walls on the old principle, to prevent them from overheating, and to do away the use of hot air, which I never found to answer. On the north side of the wall are four places or holes for cleaning each flue, 9 in. wide, and 1 ft. deep; one of which is placed within 3 ft. of each end, and the other two divide the intermediate space equally. Four bricks, as stretchers, are put into each of these holes flush with the face of the wall, laid without mortar, only pointed on the outside, to admit of being easily taken out when cleaning is required. The bricks which cover the flues are 13 or 14 inches long, and reach to the face of the wall, forming a course of headers. The wall is 21 in. thick; the stone coping is of the saddle-back form, being 6 in. thick in the middle with raised joints, 4 in. thick at the edges which project 4 in. before the face of the wall and the same behind, having a groove or throating underneath, to prevent the wet communicating with the wall. We use no wooden coping, although a temporary coping of wood is certainly of use to protect the trees in the spring when in bloom. We protect with nets for the vines and cherries. Upon the flued walls a single woollen net or double herring-net is used; the upper side fixed on nails fastened in the joints of the coping near the edge. The under side is fastened to temporary stakes about 3 ft. in length, placed about 3 ft. from the wall.



We put the net over the cherry trees when the blossom begins to expand (which is generally about the beginning of March), or a little before the expansion of the blossom if the weather is frosty. About the latter end of April the woollen net and stakes are taken away, and a single herring-net put close over the tree to protect the ripe fruit from the birds. Fire heat is put to the wall about the middle of February, and continued until the middle of May, or a little later some seasons; for, although we gather ripe fruit in the latter end of April or beginning of May, it is generally the latter end of June before the whole crop is off.\* It is generally about the latter end of June before May Duke cherries upon an unflued south wall ripen here.

With regard to the vine wall here, heat is applied, and the net put on, about the latter end of April, or when the buds have broken; when the fruit is thoroughly set, which is generally about the latter end of June, the net and stakes are removed. When the fruit begins to colour, a single net is put up, to protect it from birds; in autumn, a double net is again put up, to protect the fruit from heavy showers of rain and hail. Hamburg and Muscadine grapes upon this wall begin to ripen in September, but fire heat is continued till the whole crop is gathered and the wood ripened. We use coal dross in all our furnaces. Flues in cherry walls require cleaning every four or five years; those on vine walls once in three years. The dampers are 18 in. wide. Our furnaces are built similar to those recommended by the late Mr. Walter Nicol.

Should the foregoing statement not be deemed sufficiently explicit, I shall be most happy to endeavour to supply any further information you may require. *Erskine House Gardens, March 25. 1841.*

---

#### ART. VI. Notice of Three new Garden Tools. By H.

As you approved of the tool I described in the *Gardener's Gazette* for the 3d of April, p. 212., I think a notice and figures of a few others which I have been in the habit of using may not prove unacceptable to the readers of the *Gardener's Magazine*.

*A Drill Rake.*—*Fig. 40.* is an implement I use for drawing drills for seeds, and which I have called a drill rake. I had the teeth cut from a common hay rake, and three pieces of beech, each piece 2 in. wide and half an inch thick, screwed on to the head of the rake, so as to have each piece 3 in. deep in the clear, and to be placed at 1 ft. apart; or for drills at 9 in. apart I have four pieces. This I find a most useful and labour-saving tool, and I hope it will come into general use; as also

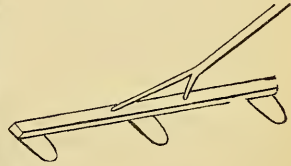

*Fig. 40. Drill Rake.*

*A Sickle Hoe* (*fig. 42.*), which I had made for loosening the ground about autumn-sown and planted crops. As will be seen by the figure, it is made in the shape of a sickle, or reaping-hook, of iron rod three eighths of an inch in diameter, and about 10 in. long in the turn, the part which enters the ground to be brought to an edge like that of a narrow chisel. I deem it one of the most essential points in the culture of culinary vegetables to keep the ground about them constantly stirred to the depth of a few inches, much depending on the crops and time of year. In the spring and summer, the

---

\* That a cherry tree should produce a succession of ripe fruit for so lengthened a period may seem strange; it is nevertheless true. We gather ripe fruit from the young bearing shoots laid close to the wall long before the blossom expands on spurs not so closely attached.

admission of the sun and air is well known to be of immense importance to vegetation, and this can only be done by loosening the ground; it will also allow the rains to penetrate quickly to the roots, as well as the absorption and retention of atmospheric moisture by capillary attraction, which is of more essential service in dry hot seasons than any waterings that can be given.

*A double Dutch Hoe.*—*Fig. 43.* is a double Dutch hoe, which I find very useful for hoeing between drilled crops when young.

*A Drill Hoe.*—*Fig. 41.* is a drill hoe, very useful for drawing drills for potatoes, peas, beans, &c.; the common hoe, turned sideways, is generally used for this purpose, but this will be found a far preferable implement.

The figures will give the necessary explanation of these implements, and of the proportions of their parts relatively to those of common hoes and rakes. I must, however, observe that the blade of the last-named tool must be put on at a less acute angle than the common draw hoes generally are.

*Sussex, April, 1841.*



*Fig. 42. Sickle Hoe.*

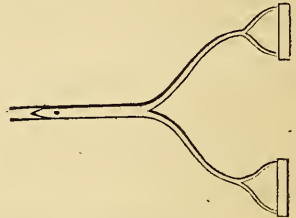

*Fig. 43. Double Dutch Hoe.*

ART. VII. *Botanical, Floricultural, and Arboricultural Notices of the Kinds of Plants newly introduced into British Gardens and Plantations, or which have been originated in them; together with additional Information respecting Plants (whether old or new) already in Cultivation: the whole intended to serve as a perpetual Supplement to the "Encyclopædia of Plants," the "Hortus Britannicus," the "Hortus Lignosus," and the "Arboretum et Fruticetum Britannicum."*

*Curtis's Botanical Magazine*; in monthly numbers, each containing seven plates; 3s. 6d. coloured, 3s. plain. Edited by Sir William Jackson Hooker, LL.D., &c., Professor of Botany in the University of Glasgow.

*Edwards's Botanical Register*; in monthly numbers, new series, each containing six plates; 3s. 6d. coloured, 3s. plain. Edited by Dr. Lindley, Professor of Botany in the University College, London.

*Maund's Botanic Garden, or Magazine of Hardy Flower Plants cultivated in Great Britain*; in monthly numbers, each containing four coloured figures in one page; large paper, 1s. 6d.; small, 1s. Edited by B. Maund, Esq., F.L.S.

*The Botanist*; in monthly numbers, each containing four plates, with two pages of letterpress; 8vo; large paper, 2s. 6d.; small paper, 1s. 6d. Conducted by B. Maund, Esq., F.L.S., assisted by the Rev. J. S. Henslow, M.A., F.L.S., &c., Professor of Botany in the University of Cambridge.

*Paxton's Magazine of Botany, and Register of Flowering Plants*; in monthly numbers; large 8vo; 2s. 6d. each.

*The Ladies' Magazine of Gardening*; in monthly numbers; 8vo, with coloured plates; 1s. 6d. each. Edited by Mrs. Loudon.

*Ranunculaceæ.*

1600. *ACONITUM* 14210 japonicum *Bot. Gard.* 783.

*Malvaceæ.*

2014. *HIBISCUS*

*Telfairiæ* Maund Mrs. Telfair's  $\pi$   $\square$  pr 2 jl Ro Mauritius 1825. C s.l.p *Bot.* 212.

A dwarf plant, with small rose-coloured flowers, raised at Bury Hill in 1825, from seeds sent from the Mauritius by Mr. Telfair, and named in honour of that gentleman's wife. (*Botanist*, March.)

*Camelliæ.*

2038. *CAMELLIA* 18166 japonica var. *Albértii* Prince Albert's *Camellia* *Paxt. Mag. of Bot.* vol. viii. [p. 53.]

A very handsome striped carnation-looking camellia, imported by Messrs. Chandler from China. (*Paxt. Mag. of Bot.*, April.)

*Balsaminææ.*

698. *IMPATIENS*

*cândida* Lindl. white  $\square$  or 6 au W Himalayas 1839. S r.m *Bot. reg.* 1841, 20.

"A noble species," with "large, white, showy flowers, a little speckled with crimson. . . . The leaves are narrow-lanceolate, tapered to a fine point, arranged in whorls of three, and edged with very fine crimson teeth. Between each pair of leaves there stands a row of crimson glands, apparently in the place of stipules." (*Bot. Reg.*, April.)

*Leguminosæ.*

1249. *CALLISTACHYS*

*longifolia* *Paxt.* long-leaved  $\pi$   $\square$  or 5 jn Y.Br.W Swan River 1839. C l.p.s *Paxt.* [mag. of bot. vol. viii. p. 31.]

This species has leaves 7 in. long, and a tall straggling stem. The flowers have a yellow standard, brownish red wings, and a whitish keel tinged with pink. (*Paxt. Mag. of Bot.*, March.)

2090. *DAUBENTONIA*

*Tripetiâna* Poir. *M. Tripet's*  $\pi$   $\square$  or 3 au S.O Buenos Ayres 1840. C. co. *Lad. mag.* [of gard. 3.]

A very handsome half-hardy shrub, with scarlet and orange pea flowers, which it continues producing from August to November. (*Ladies' Mag. of Gard.*, March.)

2123. *HEDYSARUM* 19135 sibiricum *Bot. Gard.* No. 781.

This species is often confounded with the *H. alpinum* of Linnæus, from which it is quite distinct. (*Bot. Gard.*, April.)

*Compôsîtæ.*

2273. *STEVIA*

*trachelioides* Dec. *Trachelium-like*  $\pi$  pr 3 au P Mexico 1838. D co. *Bot. mag.* 3856.

A pretty perennial, growing freely in the open border. (*Bot. Mag.*, March.)

2232. *HELICHRYSUM*

*niveum* *Grah.* snowy  $\pi$   $\triangle$  or 4 ju W.Y Swan River 1838. D co. *Bot. mag.* 3857.

A perennial species of *Helichrysum*, with large white flowers having a yellow centre. It grows freely in the open border, and flowers abundantly. (*Bot. Mag.*, March.)

2233. *TRIPTELION* 20216 spindsum *Bot. Reg.* 1841, 22.

This plant, though introduced so long since as in 1827, is very difficult to flower; Mr. Frost of Dropmore has, however, succeeded in effecting this. He says that the plant has a fleshy root like that of the dahlia, and that when it has done flowering it should be removed to a small pot during winter, to be repotted in a larger one, in sandy loam with a small quantity of rotten leaves, in spring. (*Bot. Reg.*, April.)

2348. PODOLEPIS  
aristata *Benth.* bearded ○ □ pr s Y Swan River 1840. S co. *Lad. mag. of gard.* 4.

A very pretty Swan River annual, with bright yellow flowers, raised by Mr. Hopgood of the Bayswater Nursery, from Swan River seeds imported by Captain Mangles. (*Ladies' Mag. of Gard.*, April.)

*Stylidææ.*

2581. STYLIDIUM  
Drummondii *Grah.* Mr. Drummond's ¥ Δ pr 2 n.mr Pk Swan River 1838. D co. [213. Bot.

A valuable species, from its remaining in flower all the winter, from November till March. The flowers are very large, and of a dingy pink. (*Botanist*, April.)

*Ericæææ.*

1173. ERICA 9782 Tétralix 4 Mackaiana *Bot. Gard.* 780.

*Bignoniæææ.*

CO'LEA *Bojer.* (Named in honour of *Gen. Sir G. Lowry Cole*, governor of the Mauritius.)

*floribunda Bojer*] abundant-flowering 𠄎 □ or 8 au Y.W Madagascar 1839. [reg. 1841, 19. C co. Bot.

A very handsome stove shrub, which flowered for the first time in Europe in August last, at Syon. The flowers are of a bright ochre-colour edged with white, and they are produced in whorls round the stem on the old wood. (*Bot. Reg.*, April.)

*Convolvulæææ.*

491. IPOMŒA  
ficifolia *Lindl.* fig-leaved \* Δ pr 3 n P Buenos Ayres 1840. C co. *Bot. reg.* 1841, 13.

A tuberous-rooted species, with a half-shrubby stem and showy flowers; which it produces in such abundance, that in the Western Nursery, Bristol, there are 500 flowers on a plant twelve months old, on a trellis 2 ft. high. (*Bot. Reg.*, March.)

*Boraginæææ.*

435. CYNOGLOSSUM  
glochidiatum *Benth.* burred ○ pr 2 jn B India 1840. S co. *Bot. reg.* 1841, 15.

A weedy-looking plant, with rather pretty blue flowers, and a bristly nut, whence the specific name. (*Bot. Reg.*, March.)

432. ANCHUSA  
petiolata *Hook.* petiolated Δ pr 1 o P Nepal 1840. D co. *Bot. mag.* 3858.

A pretty half-hardy perennial from Nepal, which flowers abundantly. (*Bot. Mag.*, March.)

*Scrophularinæææ.*

1718. CHELO'NE 1546 barbata.  
*Synonymes* : *Penstemon barbatus Lindl.*, *C. barbata var. mexicana Bot. Gard.* 777.

A tall-growing variety, with red flowers; introduced in 1838 from Mexico. (*Bot. Gard.*, March.)

*Labiatæææ.*

1693. SCUTELLARIA  
japonica *Maund* Japan ¥ or ½ o P.W Japan ? 1838. C co. *Bot. gard.* 778.

A dwarf species, with purple and white flowers, which flowered in Pope's Nursery, Birmingham, and is very suitable for rockwork. (*Bot. Gard.*, March.)

76. SA'L'VIA  
regla *Cav.* Regla 𠄎 □ or 5. jn S Mexico 1839. C co. *Bot. reg.* 1841, 14.

A vigorous-growing half-hardy species, with scarlet flowers, only a few of which open at one time. (*Bot. Reg.*, March.)

3451. GARDQUINIA  
betonicoides *Benth.* Betony-like ¥ Δ pr 3 o Pk Mexico 1837. D co. *Bot. mag.* 3860.

A showy perennial; very inferior, however, in beauty to the scarlet thyme, *G. Hookeri*. The present species has pinkish flowers with blue anthers. (*Bot. Mag.*, March.)

*Plumbaginææææ.*

928. ARMERIA  
fasciculata *Rom. et Sch.* fascicled ¥ Δ pr ½ au Pk South of Europe 1838. [reg. 1841, 21. D co. Bot.

This species "forms a pretty bush, looking like a young pine tree, and produces its head of pink flowers in August. During summer it grows very well in the open air; but in winter it must be treated like a Cape plant." (*Bot. Reg.*, April.)

*Orchidaceæ.*

\*SOBRA'LIA Ruiz et Pav. (In honour of *Don F. M. Sobral*, a Spanish botanist.)  
sessilis Lindl. sessile £ ☒ or 1 d Pk Peru 1840. D p.r.w Bot. reg. 1841, 17.

A very handsome plant, belonging to a genus the species of which, in Peru, "resemble reeds, loaded with large red or white, and often fragrant, flowers, which always grow from the extremity of the reed, from among the large plaited grassy leaves." (*Bot. Reg.*, March.)

2526. BRA'SSIA  
Lawrenciæna Lindl. Mrs. Lawrence's £ ☒ or 1 ja Y.B Brazil 1839. D p.r.w [1841, 18. Bot. reg.

A handsome species, very properly dedicated to so warm a patroness of floriculture as Mrs. Lawrence. (*Bot. Reg.*, March.)

3536. CYCNO'CHES 29787 Loddigèsii var. leucochilus *Bot. Mag.* t. 3855.

A white-lipped variety of this beautiful species. (*Bot. Mag.*, March.)

3523. CHY'SIS  
bractescens Lindl. bracteated £ ☒ or 1 ap W.Y Mexico 1840. D p.r.w [23. Bot. reg. 1841,

A very handsome species, being the third of this rare genus, which "is readily distinguished by its large white flowers, and great inflated leafy bracts." (*Bot. Reg.*, April.)

ODONTOGLO'SSUM  
grande Bate. grand £ ☒ or 1 d Y.B Guatemala 1839. D p.r.w [vol. viii. p. 49. Paxt. mag. of Bot.

A truly magnificent plant, which has only flowered at the Duke of Devonshire's and at Knypersley. (*Paxt. Mag. of Bot.*, April.)

*Iridaceæ.*

1913. HERBE'RTIA 16768 pulchella var. cærulea.

A slight variety, the principal difference being in the colour, which is rather more blue. (*Bot. Mag.*, April.)

*Amaryllidaceæ.*

SPREKE'LIA  
glauca Lindl. glaucous ¶ Δ or 1 my S. Mexico 1840 O s.p.l Bot. reg. 1841, 16.

This species only differs from the common jacobæa lily, in its flowers being somewhat paler and smaller, and its leaves glaucous (*Bot. Reg.*, March.)

BOMA'REA W. H.  
simplex W. H. simple ‡ Δ pr 3 jn Pk Cusco 1838. C r.m Bot. mag. 3863.

"Seeds of three varieties of this plant were brought by Mr. Pentland from different situations near Cusco, which have all flowered in the open ground at Spofforth, in front of the greenhouse." The genus was formed by Mr. Herbert out of that of *Alstrœmèria*. (*Bot. Mag.*, April.)

3333. COBU'RGIA  
coccinea scarlet ✖ ◡ or 1 mr S Cordillera 1839. O r.m Bot. mag. 3865.

The flowers are much smaller than in the common species; but it seems more hardy, as it stood out "all the summer and autumn of 1839, the season being unusually wet and cold, and appeared to dislike sunshine and fine weather." (*Bot. Mag.*, April.)

trichroma W. Herb. three-coloured ✖ ◡ or 1 jn S.G.W Andes 1837. O r.m [3867. Bot. mag.

This species differs from the preceding one in having larger flowers, and their being distinctly striped with white and green. (*Bot. Mag.*, April.)

CALLITHAUMA W. Herb.  
viridiflorum W. H. green-flwd. } ✖ ◡ cu 1 jn G Peru 1837. O r.m Bot. mag. 3866.  
angustifolium W. H. narrow-lvd. }

The plate exhibits two species of this rare genus, which Mr. Herbert thinks will prove a section of *Cobúrgia*. (*Bot. Mag.*, April.)

ART. VIII. *On the Shanking of Grapes.* By A. SAUL.

ALTHOUGH the shanking of grapes is a subject which has often been discussed, there is, in my opinion, one cause, and probably in many cases the only one, which has not been hit upon. The keeping up of too much moisture in the house in proportion to the heat is, in my opinion, more often the cause of the shanking and shriveling of grapes than any other. Without at all questioning the rationality of the opinions of other writers, except in so far as to say that the cause imputed by J. B. W., in conjunction with my own, is, I believe, the right one, I may state that I have had sufficient proof that my own opinion is correct.

In 1838 I had two houses of grapes very nearly ripe at the same time; one was a fruiting-house for pines, the other a succession-house. The difference in the temperature of the two houses was about 10°. The degree of moisture, by sprinkling the paths, flues, &c., had been kept nearly the same in both. In consequence of the grapes in the succession house being considerably shanked, while scarcely a single berry in the fruiting-house had suffered, I was led to infer that the moisture had been too much in proportion to the heat. Acting in accordance with that opinion, I, in the following summer, kept the succession-house nearly dry, keeping it in that state till the grapes were ripe. The consequence was, as I had anticipated, nearly the extirpation of the disease. I have since acted upon the same principle, with the same results; and am now fully convinced that the real and only causes of the shanking and shriveling of grapes are too much moisture in the house, and deep and badly drained borders. The one, by keeping the roots in a cold unhealthy state, prevents, in some measure, the proper supply of pure sap to the plant; while the other, by acting upon the plant as a cold damp atmosphere acts upon the human body, prevents in like manner the free circulation of the life blood of the plant.

*Castle Hill Gardens, April 8. 1841.*

---



---

 ART. IX. *On the Culture of the Cucumber in Pits heated by hot Water.* By W. H.

I SEND you for insertion in the *Gardener's Magazine* my mode of growing cucumbers and melons by hot water; a plan which I have practised for ten years with a success equal to growing them with dung, and with a deal less trouble. From my ten years' experience, I can confidently recommend it as an excellent way of growing them where dung is scarce and fuel plentiful.

I have a double row of pits, 38 ft. long, and 7½ ft. wide,

heated by one boiler upon the siphon principle, with cisterns at the farther end, and lids on them to put water in when necessary. In the one row the pipes go and return along the front, and a flue along the back. In the other row, which is the one appropriated for winter and early forcing, a flue goes along the back, covered with paneled squares, and painted: the top pipe goes along the front, and the bottom pipe returns in a channel in the bottom of a tank in the bottom of the pit. The smoke is turned along these back flues, when required, by dampers in the fireplace, and when not wanted there is a third flue on the outside of the pits for it to go along; and all these flues are continued across a walk at the end of the pits into a chimney at the end of a Calcutta pit. When I first began, I had a chimney over the boiler to turn the smoke up when I did not want it to run along either of the pits; but this covered the lights so with blacks that I was obliged to have it taken down, and a flue run along the outside, as before stated. Stop-cocks are placed in the pipes, so that either row may be worked separately, or both together. The tank in the early-forcing row extends the whole length, and nearly the whole breadth, of the pit; and is supplied with water by a small pipe from a main, with a cock to regulate the supply. At the opposite end there is a large pipe, with an elbow joint, which communicates with the tank, and shows the quantity of water that is in it. Below the large pipe there is a small one with a cock, which empties into a drain, to draw off the water from the tank when repairs are necessary. The tank is made with bricks and mortar, and cemented; the channel in the bottom for the return-pipe is 1 ft. wide and 6 in. deep: on each side of this channel there is a brick flat, pigeon-holed and covered with flag-stones, to protect the pipe. The pit is divided into four compartments, of two lights each: in each of these divisions there are two cross-drains communicating with the return-pipe, and covered with oak planks. These oak planks have circular holes cut at each end, and upon these circular upright pipes are placed, 6 in. wide at bottom and 3 in. wide at top. By these steam is admitted into the divisions, and air is circulated: when not wanted, they are covered with pieces of slate. The pit is filled with leaves nearly up to the glass, to allow for sinking; and, when they have sunk sufficiently low, the hillocks of soil are put in, and the plants are planted as soon as the soil is warm. As long as the leaves contain sufficient moisture, the water in the tank is confined to the channel for the hot-water pipe; but when the leaves begin to get dry, the water is turned in, so as to fill the tank, and then allowed to evaporate into its usual channel. By this simple process I can always keep a proper moisture in the pits, highly conducive to the growth of cucumbers and melons. When I first began

growing cucumbers and melons by hot water, I formed a chamber over the tank, by placing spars across the tank and covering them with turves: upon these I put about 1 ft. of prepared dung, and then the soil in the usual way. I grew very good cucumbers in this way; but the beds were only of short duration, owing to the dung and soil becoming dry, and the difficulty of keeping them moist.

As the season advances, and the sun becomes powerful, the pieces of slate are put on the steam-pipes during the day, and taken off at night; but when the melons are in flower, and ripening their fruit, they are kept on day and night. When the melons are done with, I use the pits for striking crowns and suckers, and find them to answer admirably.

*Mawley Hall, Bewdley, March 22. 1841.*

---

ART. X. *On growing Strawberries for Forcing.* By a GARDENER  
OUT OF PLACE.

As the system I have pursued successfully for several years in growing strawberries for forcing differs, in some respects, from that of Mr. Fish (p. 39.), I send a note of the details. As soon as the runners are fit for the purpose, I lay a quantity, say two or three in a 32 pot, others one in a 60, in a good strong loam, with a portion of well-decayed manure. I place a stone on each runner, for the double purpose of keeping the plant in position, and preserving moisture to the roots. The first runners I prefer: the sort Keen's seedling. As soon as the plants are well rooted, I replot the sixties into thirty-twos, and the thirty-twos into twenty-fours, still using the same strong soil; I then place them in the hottest part of the garden, fully exposed to the direct rays of the sun, but not under a wall. The situation I prefer is the centre of the vine border, first placing a quantity of half-decayed manure, generally some old dung lining, to put round the pots, to prevent the sun acting too powerfully on the roots. Here they are left exposed to the elements most conducive to bring them rapidly to a state of maturity; a free circulation of air, abundance of moisture, which I take care they are liberally supplied with, and a full share of solar heat. In this situation the plants grow freely, forming well-matured crowns, to send up fine stems of bloom in the forcing-house, with strong and vigorous roots to support them. Those in twenty-fours remain; after a time I examine the others, and those that have the strongest roots I replot into twenty-fours, pursuing the same method as before; so that, out of 700 or 800 pots, I have half the number in twenty-fours, with one, two, or three plants in a pot, and the remainder in thirty-twos, with



one plant in a pot. I prefer one plant to either-sized pot in preference to a greater number; and, if the above method is pursued, it will, from the rapidity of their growth, be found quite sufficient. If the autumnal rains are heavy, I lay them on their sides; and, about the middle of December, place them in some frames to keep the frost from injuring the roots, till they are placed in the forcing-house. I shall say nothing of their appearance in the house, but leave it to the imagination. After forcing them, I turn them out of the pots, and plunge them in rows, at moderate distances, in a piece of spare ground in the garden, well exposed to the sun and a free circulation of air. (From these you will have a slight gathering after the natural crops are over.) In the autumn I take them up with good balls of earth, and plant them in rows in a melon pit of about 30 lights, which I fill full, placing them rather thick, to economise the rows, and press the mould firmly to their roots. The pit has neither bottom-heat nor pipes, but is simply covered with mats. As soon as the frosts set in I place the lights on, but do not begin to cover up with mats before March. If warm showers come in April I take the lights off, and let the plants have the benefit (which is better than watering from a pot), to forward them. When the sun is shining hot in the afternoon I shut up close, and cover up directly with double mats. You will find the next morning a sensible difference in their appearance. These plants will bear abundantly, coming in at a very seasonable time, just before the out-door strawberries, which are very often retarded by late frosts; when, the days being generally very hot, strawberries are in great demand, and, it being too hot for them in the houses, they are sometimes very scarce. After the fruit is gathered, the plants are dug up and thrown away, and the pit planted with melons.

By following this simple routine, year after year, you will be able to supply a family, however large, with abundant crops of this beautiful fruit, in the highest state of perfection, and at a very trifling expense.

Now I am on the subject of strawberries, do you know if it is any where recorded why the strawberry leaf was first chosen to garnish the coronets of the three superior orders of our nobility, in preference to the leaf of the oak,

— “a prince’s refuge once,  
The eternal guard of England’s throne,”

which would appear to be a much better emblem? Shakspeare has written, “the strawberry grows underneath the nettle,” but he has not stated why the plant is honoured so far as to be elevated above the brow of a duke.

*Camberwell, Feb. 1. 1841.*

ART. XI. *On the Hautbois Strawberry.* By WM. ANDERSON, F.L.S., Curator of the Chelsea Botanic Garden.

HAVING seen three papers in the *Gardener's Magazine* describing the hautbois strawberry, none of which is correct, I beg you to state what little I have seen of that plant and its fruit.

I have seen the hautbois strawberry in its native state in the bottom of old chalk pits, in the copse woods about one mile beyond Tring, on the high ground on the left hand. This ground is a strong chalky yellow clay. The fallen leaves, and other decayed vegetable matter, rest on and manure these pits, and I was told that the plants produced good large berries, but were gathered by birds and children before they were ripe.

To cultivate this fruit, care must be taken to select the hermaphrodite plants while they are in flower, there being three sexes in the seed-bed, i. e., male, female, and hermaphrodite. When a few of the last are selected, they will give runners abundantly; and when these runners are planted on a strong rich clayey soil they will produce great crops. This sexual character was first pointed out to the late Sir Joseph Banks about the year 1817, and he had great crops from these selected plants; he also supplied his neighbour, Mr. Wilmot, with plants, who had about two acres in cultivation of them in 1820; the clusters of fruit were so large that he had them all tied up to small twigs. From his success I had flattered myself that this most desirable fruit would have been abundant in Covent Garden Market, but we never see it for sale. I have also seen Mr. Oldacre produce great crops of these berries forced; those that have once tried them for this purpose will prefer them both for size and flavour. I must, however, remind your readers that it is in vain to grow this strawberry in the usual way of the other varieties; but the nearer we come to that chalky clay, or strong loamy ground highly manured, such as Mr. Wilmot's is, the greater will be our success.

I have been rather tedious, but my wish is to see the hautbois the leading strawberry in forcing and in cultivation; as it is the best flavoured, and the best bearer where the ground will suit it. I keep the hermaphrodite plants in the garden, but we never see fruit although they flower very freely; the ground burns up in the first dry weather in April and May, and prevents them coming to perfection.

*Apothecaries' Garden, Chelsea, March, 1841.*

ART. XII. *On the Culture of the Conical-fruited Scarlet Alpine Strawberry.* By W. GORDON, Gardener to the English Embassy, Paris.

I SEND you a short sketch of our mode of cultivating this fine strawberry, called by us the Four Seasons, from its producing its

fine rich-flavoured ripe fruit from the end of April to the middle of November, and sometimes later, according to the mildness of the season, in the open ground. This four seasons, or conical-fruited scarlet alpine strawberry, is one of the very best sorts for general cultivation. The size of the fruit is from half to three quarters of an inch long; the flesh firm, of a fine shape, and delicious flavour, even to the end of the season. The plant is continually in flower, and produces ripe fruit till it is checked by the hard frosts and cold nights of autumn. To give its botanical characters in this paper may be of little or no importance to the cultivator, I shall therefore merely state what country or place it originally came from, as near as possible. According to some accounts, it is a native of Switzerland and Germany, and was first cultivated in England in 1768; or, at least, some strawberries bearing the same name were then introduced and cultivated. But it is no easy matter to say precisely where this fine sort came from. I consider it to be only obtained from seed, for a short time ago it did not exist, or, if so, it was in a small quantity; but it is in general cultivation at present, and is greatly improving in size. There is also another sort of the four seasons alpine strawberry, the fruit of which is of a compressed oval shape, not so large as the former sort, but of a good flavour, and very productive. The only difference is in the shape of the fruit. I have got a new white alpine strawberry, which came from seed, nearly of the same shape as the former, of good flavour, but not so productive. The colour of its fruit may be some inducement to its cultivation.

During the last two winters these sorts of strawberries seem to have suffered the most in the neighbourhood of Paris. This last winter of 1839, or spring of 1840, in particular, they suffered greatly, as most of the young plants were killed, as well as some of the weak old stools, which has left the young plants rather poor. The pine strawberry and Keen's seedling did not suffer so much as the alpine sorts have done, which may appear remarkable.

The mode of cultivating this strawberry is as follows:—

When we are desirous of having large fruit, we make a new plantation of the young strong runners taken off the three-years-old stools, which are the best. These we plant in beds 6 ft. wide, and four rows in the bed, leaving an alley on each side of the bed. The plants are placed two together, and at the distance in the rows of from 15 in. to 18 in. apart. The more room they have the better, if the ground is poor; but they may be set closer, if it is rich. They must still, however, be planted wide in the rows. In planting, great care is required not to set them too deep, as I find they do best when only about one third of their roots is put in the ground, a small space being left

between the ground and bases of the leaves; they will soon make fresh young roots. After planting, nothing is to be done but to lay a little short dung on the surface of the bed, and give a little water. They must not be allowed to make any runners; or, if they do, they must be all taken off, which causes them to form good strong plants and stools. Spring or autumn is the best time to make plantations. One of these plantations will be good for four or five years; after which time the soil begins to get exhausted by over-bearing; so that you will require to renew them by making fresh beds every other year, if not yearly.

Those plantations made either in the spring or autumn will produce good ripe fruit in the September and October of the same year. Three or four years old is the best time to allow them to make runners to get stock from to make plantations. If once they are allowed to produce runners, they soon run out and become small-fruited. By their not being allowed to make runners, the plants are stocking themselves by making young offsets, which are continually flowering and fruiting the whole season.

Some gardeners prefer sowing the seed of this strawberry, which they consider the best mode of cultivating it; as it is said to last longer, bear finer fruit, and not to run out so soon. The beds, it is said, will stand good for six years. By sowing the seed of this strawberry, one advantage may be obtained, namely, that of raising new sorts or varieties; but nothing more: for, if the seed is sown in the spring, it will require at least a year and a half before you obtain any fruit, and this is not certain even then before the following year. For my part, I find no advantage in sowing whatever, except in obtaining new sorts. Care in planting this strawberry is the chief thing, and afterwards not over-watering it.

The soil which suits these strawberries is a light sandy soil, neither too rich nor too poor; one with a quantity of old lime rubbish in it, and where the water will pass quickly off, seems to suit them best. In the hot dry weather they require to have a good supply of water to keep them fruiting, otherwise they will not fruit so large or fine. Care must be had not to let the soil get too moist. If they make too many leaves, let them have no water, or even take off the covering of rotten dung; for the soil is too rich for them, and they are growing too strong to fruit well. Take off all the old leaves, and expose them to the sun as much as you can. When once they commence fruiting, you will have plenty. Be careful not to plant them where there is any shade whatever, but in a place that is fully exposed to the sun, and where there is a free circulation of air, otherwise they will not fruit well or in any quantity.

This is also one of the best strawberries for forcing, by taking the two- or three-years-old stools, and putting them into small-

sized pots in the spring of the same year or autumn, or, as you may want them, as they come into flower; all of which I have done, and found them to answer my purpose well.

In France it does not do to pot the young runners to force as in England: they do not grow strong enough to force in the following year; they must be at least two years old.

The seed of this strawberry should be saved in September and October, when it is best, and it ought to be sown in February or March, as the mildness of the season will admit.

*Paris, August, 1840.*

*Justicia Adhátoda* has stood out in Paris, and was only killed at  $14\frac{1}{2}^{\circ}$  Reaumur, or about  $7^{\circ}$  below the freezing point of Fahrenheit, in 1837 and 1838. It makes a fine shrub, and flowers well; I am not certain if it seeds.—*W. G.* [See p. 250.]

ART. XIII. *On Forcing Sea-kale.* By ROBERT ERRINGTON.

THE following is a mode of forcing that useful vegetable sea-kale, which, in my opinion, merits general adoption. I am aware that it is not altogether novel, yet it is, in my opinion, not sufficiently known; and, in recommendation of it, I can only add that by it I have had a continual supply, without a single day's intermission, since the middle of last November, and that of the very best quality.

I force it in the mushroom-house; and, to obtain a supply of roots, I plant four rows in the open ground every spring. My rows are 60 ft. long, 3 ft. apart, and 15 in. between the plants in the row. It of course receives proper cultivation in this stage, the plants having been raised from seed the year previous in a single drill. The roots are taken up for forcing as soon as the leaves are decaying, and with much care; and as much as possible taken up entire, as the root is of course a magazine of nourishment for the incipient bud. The main stock is then "laid by the heels," and covered with litter until wanted. In my mushroom-house I have a pit or trench sunk below the level of the floor line about 4 ft.: this furnishes room in the length of the house for about four successive ages; and I introduce the second lot of roots the moment the first begins to bud, and so on with the rest. I place fermenting matter, viz. dung and leaves mixed, about 2 ft. 6 in. deep, under the roots, taking care to have bottom-heat enough; as, if that becomes too hot, I can easily reduce the heat with water; and the more water the sea-kale receives in this way, the more tender it becomes. I place the roots in this fermenting matter as thick as they will stand, merely flooding in some fine old tan or old rich soil with water, to fill the crevices between the roots completely. \* The surface

of the crowns, when so placed, is a foot, or nearly so, below the floor line; and, when planted, I lay a row of trusses of straw side by side over the whole, to shut in the steam, and keep it completely dark, which is one of the main points; and, with the straw and the shutters, this is completely effected.

In the same house I produce a continual supply of chiccory, rhubarb, and lily of the valley, in pots, by the same system; besides various other things which, in emergencies, find a refuge there. — *Oulton Park Gardens, April 4. 1841.*

## REVIEWS.

ART. I. *Three Lectures on Agriculture; delivered at Oxford on July 22. and Nov. 25. 1840, and on Jan. 26. 1841; in which the Chemical Operation of Manures is particularly considered, and the Scientific Principles explained upon which their Efficacy appears to depend.* By Charles Daubeny, M.D., F.R.S., M.R.S.A., &c., Sibthorpian Professor of Rural Economy in the University of Oxford. 8vo, pp. 106. Oxford, 1841.

It rarely happens that an individual can be found so admirably adapted for being appointed a scientific Professor of Agriculture as Dr. Daubeny; known as he is to be a profound chemist, and the actual Professor of Botany in the same university in which he holds the Agricultural Chair. The publication of these *Lectures* so shortly after the appearance of Liebig's work is interesting, as affording an opportunity of observing in what two eminent chemists, who have devoted their energies to the same department of their science, agree and differ; and it is satisfactory to find a general harmony between them. "In these lectures," Dr. Daubeny observes, "although I freely own myself indebted for the fundamental doctrines that have been laid down, as well as for many of the details that have been dwelt upon, to the work of Professor Liebig, yet it is fair, both to him and to myself, to state that I have interwoven much matter that is either my own, or drawn from other sources than those of his work; that I have often attempted to deduce from his principles consequences for which he is nowise answerable; and that I have endeavoured to remove any impediments that may exist amongst agriculturists to the reception of the novel views propounded in his Report, by giving to my exposition of them as much as possible of an English character, both as to style and arrangement, and by disencumbering it of all such references to recondite chemical truths as did not seem essential to the establishment of the leading propositions." (Pref. p. vii.)

This extract will enable our readers to form some idea of the work, and to those who have paid some attention to chemistry, and have studied Liebig, and Mr. Lymburn's article on the subject (p. 97.), Dr. Daubeny's *Lectures* will be found pregnant with interest and instruction. We hope, however, to be favoured with some remarks on the subject of the *Lectures* by Mr. Lymburn, who is at once a scientific chemist and a cultivator of extensive experience and observation.

ART. II. *The Eastern Arboretum, or Rural Register of all the remarkable Trees, Seats, Gardens, &c., in the County of Norfolk.* By James Grigor. Illustrated by drawings of trees, etched on copper. Nos. VIII. to XI. 8vo. London and Norwich. 1s. each.

Our last notice of this work was in p. 29.; the last residence we mentioned

was Scottow Park, and the last of our trees the weeping willow ; we shall now enumerate the seats and trees noticed up to the end of No. XI.

*Houghton Park ; the Seat of the Marquess of Cholmondeley.* — “ Every thing, except the trees, seems to have suffered by the long lapse of years : on their heads it has put fresh honours ; and if in some instances they are sinking into dilapitude, their decay is unattended by any of that regret which we experience in beholding the untimely abandonment of the buildings.”

*Hunstanton Park ; H. Le Strange Styleman Le Strange, Esq.* — “ Parts of the house are of great age, having a staircase, each step of which is formed of a single solid block of oak. The carved-work round the doors, and the paneling of the drawingroom, with its rich cornice, are truly beautiful. The tops of the hills, with their precipitous edges, are well clothed with young and thriving plantations. The evergreen oak (*Quercus Ilex*) and the cedar of Lebanon, which are in profusion here, have grown with great rapidity, and create a deep massive effect. Here are also many goodly oaks, which fling their branches around, and raise their lofty heads in defiance of the sea breezes.”

*Sprowston Park ; Rev. W. J. Carver.* — “ Around the hall there are several lofty poplars (*Populus fastigiata*) with trunks measuring each 10 ft. in circumference ; a cluster pine (*Pinus Pinaster*) 9 ft. 8 in. ; together with some fine specimens of the elm and beech. At the north-west front of the building, in the park, is an oak called ‘ The King of Sprowston,’ a wide-extending regular tree, having a stem of 15 ft. in circumference, the branches overspreading a space of 29 yards in diameter. In the same direction, and close by the road to Rackheath, is an extraordinary lime tree (*Tilia europæa*), which has attracted the attention of many a spectator.”

*Rackheath Park ; Sir Edward Stracey, Bart.* — “ This demesne forms a fair and plentiful show, not yet grand, but abounding in all the elements which in after years will make it so. The impress of beauty is upon it now, in the usual outlines of youthfulness : we have no dark forest-sides here ; no avenues with their cathedral-like vistas ; few trees which tempests have vexed, and fewer moulded into the picturesque forms of extreme age. All these have to follow.”

*Wroxham House Park ; Rev. John Humfrey.* — “ Seldom have we witnessed a place of the same extent, and it is far from being large, abounding in so much fine timber. The oaks around the house are of goodly dimensions, bearing that bold contorted outline which is at once so beautiful and so characteristic of the species. The Scotch pines here are also well worthy of notice, and the beeches and horsechestnuts far from contemptible.”

*Hoveton House Park ; Rev. Thomas C. Blofeld.* — “ The Portugal laurels in front of the house, although not so tall as some that we have seen, are of great circumference. There is also a choice selection of hawthorns, which, with the holly, have found a soil to rejoice in. The walnut (*Juglans regia*) has arrived at a considerable size ; and we noticed a copper beech assuming all the character of the common one. Otherwise, it is more the general appearance of the place, than any trees of particular beauty, which here attracts attention.”

*Spirworth Park ; John Longe, Esq.* — “ A splendid conservatory is appended to the south end of the house : we may venture to say, there are few, if any, which can compete with it in the county. It is beautifully arranged, and replete with exotics and other plants of many of the rarer tribes. The ornamental grounds are kept with that neatness and ‘ lucidus ordo’ so indispensable to produce effect. They are of very considerable extent, and in perfect harmony with the date of the mansion. Here is a smooth greensward, with noble beech trees feathered down to the ground. The elegant vases, half-hidden with creepers, scattered over the parterres, give peculiar effect to that class of plants, and bestow throughout a dressy and finished appearance.”

*Wroxham Hall ; Sigismund Trafford, Esq.* — “ The great use of trees is to

wait upon the mansion, lending their aid to it in all their varied character, whether placed singly, in lines, groups, or thickets; as objects merely ornamental, or valuable on account of their shelter. Otherwise, what are they? A chaos of beautiful materials, indeed, but serving only to create the more insufferable discord."

*Beeston Park; Sir Jacob H. Preston, Bart.* — "The entrance to the park from the Norwich road is particularly handsome: after passing a sufficiency of plantation to betoken the approach of some place of note, the grounds open with a most magnificent avenue of oaks, exhibiting a sweep of a full quarter of a mile, continuing uninterruptedly almost to the very verge of the mansion."

*Worstead House; Hon. W. R. Rous.* — "The present proprietor has, with good taste, effected an entrance to his house at the opposite extremity to that which was previously in use, thereby making the original entrance hall a tribune, and giving an entire suite of apartments the repose and seclusion of a dress-ground, sweeping down to the water's edge."

*Honing Hall; E. G. Cubitt, Esq.* — "Great facilities are afforded for a pleasure-ground and dress-garden; for, in the immediate vicinity of the house, the trees, both beech and oak, are very fine: we measured several 12 ft. in circumference, with 30 ft. of clear shaft; but this department has been little attended to, and, with the exceptions of a Portugal laurel, one of the finest we have ever witnessed, and a handsome tulip tree, there is little worthy of record."

*Wilton Park; Lord Wodehouse.* — "The grand approach, through nearly a mile of fine young thriving wood, gives the place a very imposing character; and proves that with care and attention most species of wood may be reared, even though exposed to continual sea breezes: we, in a great measure, impute this to the large body in which they have been planted."

*Bayfield Hall; G. N. Best, Esq.* — "The ornamental grounds are in good taste, and, with the ruin of Bayfield church peering through ivy and sylvan drapery, makes a happy picture. The lawn breaks and undulates on all sides in very pleasing variety."

*Gunthorpe Hall; Rev. J. H. Sparke.* — "Some hundreds of acres are here thickly strewed with thorns and holly of most magnificent growth, and ever and anon an old and gnarled oak contrasts and enlivens the scenery. The gardens are somewhat after the old fashion, and the greenhouse, which is of iron framework of a continuous curve throughout, is the lightest, prettiest, and most convenient we ever beheld. There is a handsome piece of water, fringed chiefly by ash and alder, affording to the grounds a most pleasing termination."

*Letton Park; T. T. Gurdon, Esq.* — "Here, as in many places in Norfolk, nothing strikes us more forcibly than the want of that diversity of surface so necessary to every demesne. Besides creating an impression, a varied and broken outline gives at once scope to the imagination: a small group of trees, happily placed on a knoll, or on the turn of a sloping hill, often deludes one with the idea, that the brokenness of the ground conceals more even than the eye beholds; but on a level space, a handsome expanse of wood scarcely produces any effect, and many a broad acre of greensward is thereby rendered comparatively of little account. From its being built on so flat a surface, few houses verify this observation more than the one in question; for, although replete with every possible convenience, and containing a most ample suite of apartments, its appearance does no justice to its interior arrangements."

*Plumstead Hall; Rev. Charles Penrice.* — "The house stands in the midst of a spacious lawn, surrounded by well-pruned and thriving plantations. Under all circumstances, it would be unreasonable, perhaps, to expect a happier combination; and, without infinite perseverance, nothing so good would have been the result. There is one feature, however, which we cannot commend. The approach from Norwich, to say nothing of the garden wall and gooseberry bushes, makes sad havoc with the dress-grounds: it precludes their being



private—their first, best charm—and interblends two styles of opposite character.”

*Shotesham Park; Robert Fellowes, Esq.* — “It is a well-understood phrase in writing, that a book or character is not well sustained; and the case is quite analogous, and the rule equally applicable, in reference to a landscape: all things should be in keeping and consonance. Once create an ill impression, and it may prove beyond your power to remove it; for many a splendid seat has sunk below its just appreciation by unworthy objects presenting themselves on the first appearance.”

*Brooke Hall; Rev. John Holmes.* — “The groups of trees, transplanted after the suggestions of Sir H. Stuart, are most judiciously arranged. They screen and partially hide what would otherwise have presented a full and staring front of the entire residence, at the same time occupying a bald and otherwise bleak outline. These trees have been removed with great care, and prove that, under proper management, they are available to create an appearance full twenty years in advance of those planted in the usual way.”

*Brooke House; G. S. Kett, Esq.* — “The ‘varied dependencies’ of this residence are interesting in many ways: to the mere observer of general nature; to the more minute botanical student, who would enquire as to the ‘new-comers’ in the hardy ligneous department of his great family; to the florist; to the grape-grower; to the landscape-gardener, who has to operate on flat surfaces; and, finally, to all who delight in beholding a pleasure-garden kept in the most perfect taste, whether we look at its walks, hedges, borders, verges; the enamel of the greensward, or the disposition and character of the objects which rise thereon. In the youthful department here, by far the most interesting section to us is the collection of *Coniferæ*. *Cedrus Deodara*, raised here from seed in 1830, and planted in its present situation in 1834, is now 9 ft. high, in a most vigorous state of growth.”

*Seething Hall; Mrs. Kett.* — “An ancient-looking secluded place; deserving of notice chiefly on account of its trees and its unique collection of water-fowl, foreign and indigenous.”

*Kirby Cane Hall; Right Hon. Lord Berners.* — “The grounds are much road-bound; and the entrance-gates, one of which is close to the mansion, are of that thin wiry iron which always creates a prim and unpark-like effect, and which at best is only suited to a parsonage or suburban villa.”

*Ditchingham House; J. L. Bedingfeld, Esq.* — “On the opposite side of the lake rises a fine extent of woodland scenery, which, by a most skilful arrangement, is kept low in front; thereby affording a full view of the stems of the trees behind, giving the appearance of greater depth, and adding much to the apparent height of the acclivity. This effect is further improved by an open glade with greensward in the midst of it, and a dense mass of Scotch pines as a further contrast.”

*Earsham Park; Sir W. Windham Dalling, Bart.* — “Perhaps the most remarkable objects that presented themselves to our inspection were some old thorns that were fast falling into the ‘sere and yellow leaf,’ and exhibiting every symptom of extreme old age. We question if the old trees of this species which are at Kimberley approach them either in size or beauty. We rode under one, a perfect canopy, with a globular head spreading around like a mushroom, the mistletoe, at all times green and bright, creeping through its branches. Its trunk is a series of stems massed and matted together, measuring, at 5 ft. high, 9 ft. in circumference. Another stood not far apart, of one solid bole of yet greater magnitude, being, at 10 ft. from the ground, full 10 ft. in circumference. There is no other of the smaller tribes of trees which we consider creates so park-like an appearance as the thorn, when once it has attained a certain age and stature; we associate it with no particular locality, and it serves as a screen or an ornament in any situation that demands its aid. The gardens, well sheltered by a wood, contain some fine and well-grown shrubs.”

*Gillingham Hall; Miss Schutz.* — “In front of the house stands the noblest

specimen of evergreen oak (*Quercus Ilex*) it was ever our good fortune, not forgetting those truly splendid ones at Holkham, to witness. It measures, at 1 ft. from the ground, 14 ft. in girth, but the stem is short, and breaks out on every side into innumerable branches, forming a most noble and almost circular head, which, in a dense and impervious cluster, covers a space of beyond 180 ft. in circumference. We noticed a plane (*Platanus occidentalis*) which, at the root, was 13 ft. in circumference. Another, standing prominently forth, in full view from the house, 14 ft. in girth, with boughs forming a fine flowing outline, nearly sweeping to the ground, and, at the extremity, extending over a circle of 190 ft. We also observed a lime (*Tilia europæa*) forming a group in conjunction with an elm and a plane: of the two former, one was 12 ft., and the other 11 ft., in circumference."

*Raveningham Hall; Sir Edmund Bacon, Bart.*—“ We observed, on one extremity of the grounds, what we have never, so far as we remember, before witnessed, a grove of old and well-grown sycamores, which for many years has served for an ample rookery. But, with the exception of a few ashes and a silver fir of considerable magnitude, the trees are chiefly oak, and are devoid of that charm which is produced where a greater variety prevails.”

We have, we trust, given enough in the way of foretaste of these interesting places, to induce those who wish to see them described and reasoned on in detail to procure Mr. Grigor's work. We hope, when Mr. Grigor has completed Norfolk, he will undertake Suffolk; and, in short, make a business of describing grounds, and recording the dimensions of remarkable trees and shrubs; because we feel confident that his doing so would increase the taste for gardening and planting, already very general, but very far from what it ought to be, considering the resources afforded by our nurseries.

*Our Trees* in these Numbers are: No. 8. the Larch; No. 9. the Ash; No. 10. the White Willow; No. 11. the Beech; and No. 12. the Horsechestnut. The articles on these trees are practical and most judicious, and their perusal will amply repay both the gardener and the amateur. The engravings which accompany the work are of oaks, elms, limes, a poplar, a willow, and others, all fine or remarkable specimens, and, for the most part, well executed.

ART. III. *Cucumber Culture; being a Practical Illustration of a System of Forcing in connexion with Natural Principles, especially in relation to Winter and Scientific Modes of Growth: wherein it is shown that Fruit may be cut during the whole Year, in beautiful Perfection, on Beds and Pits of new and improved Construction, and in the Stove.* By John Duncan, author of “Culture of the Melon,” &c., gardener to T. Daniel, Esq., Henbury, near Bristol. 12mo, pp. 124, 1 plate. London, 1841.

THE title will give the reader some idea of the manner in which Mr. Duncan treats his subject, which is altogether different from that of Mr. Mills's work, noticed in p. 229. Mr. Mills founds his practice on experience, and Mr. Duncan partly on experience, but principally on a general scientific knowledge of the agents of culture. Whoever would master the subject of cucumber culture should possess themselves of both works; unless they can already grow cucumbers and melons with the success of our correspondent W. H. at Mawley Hall. (See p. 262.)

ART. IV. *Transactions of the Society for the Encouragement of Arts, Manufactures, and Commerce.* Vol. LII. Part II., and Vol. LIII. Part I. 8vo. London, 1839 and 1840.

OUR last notice of this excellent work was in our Volume for 1839, p. 281. In the first of the parts before us there is a very interesting paper, “describing

the recent Improvements in the agricultural Management of the Fen Districts of Cambridge and the adjacent counties. These improvements are founded on the discovery of beds of calcareous marl, lying almost everywhere below the peaty and silty surface of the fen. A very simple and economical method of raising the marl, and distributing it over the surface, has been found out; the result of which (combined with the perfect system of drainage by the use of the steam-engine) has been, that lands which, in the usual course, produced only two grain crops, both of them oats, now yield one crop of oats and two of wheat." (Preface, p. vii.)

A paper by Col. Le Couteur, which, though of immediate interest to the farmer, is yet, by analogy, applicable in horticulture, well deserves notice. The Wheat Plant, "as is well known, has two kinds of roots; namely, the seminal, which are first produced, and descend to a considerable depth in the soil, and the coronal, which shoot out afterwards around the crown of the plant immediately previous to its tillering. Col. Le Couteur seems to have ascertained that wheat sown in drills 7 or 9 inches apart, and covered to the depth of about 3 in., is in the most favourable circumstances for the due development of these two sets of roots; whereas, in wheat sown broadcast, those grains that are only just covered with soil exhibit the two kinds of roots mixed and crowded together. In wheat sown about Christmas or in January, the coronal roots begin to appear about eighty days after the germination of the seed. This, therefore, is the proper time to give the principal hoeing, as at this time the weeds may be cut up without any risk of interfering with the coronal roots; and, by stirring and loosening the ground, so much encouragement is given to the growth of them, that they soon extend quite across the drills, occupying the ground to the almost exclusion of the deeper-rooted weeds, and throwing out a luxuriant growth of side shoots, the forerunners and causes of an abundant crop." (p. vi.)

Some Seedling Potatoes have been sent to the Society by Mr. Buchanan, the produce of the second year's growth, which are to be further cultivated, and the results communicated to the public in vol. liii.

Part 1. of vol. liii. contains an account of Mr. Paxton's Machine for making Sash-Bars, referred to in our Volume for 1839, p. 453., and for 1840, p. 572., and for which Mr. Paxton obtained the silver medal. The machine is too complicated and expensive to be erected by individuals; but it cannot fail, we think, to become an essential part of the furniture of every extensive carpenter and builder.

"The motive power is from an engine of four and a half horse power employed on the premises for other purposes. Half of this power is required for the sash-bar machine, and half the expense of the engine, including attendance, &c., is 5s. a day. The machine can make bars at the rate of 600 ft. an hour; but it cannot continue long at this rate, as time is required both to cool and sharpen the saws. The average number of bars per day is 500 4-foot lengths, or 2000 ft. The greater number of bars used here have been made from Riga deal, and some from oak, &c.; but any well-seasoned wood may be used. The attendants required for the machine are only a labouring man and a boy. The first cost was 20l." (p. 101.)

The following article "On the probable Uses of Coal-dust as a Manure, and on the Nitrates and on Manganese," will be read with interest, as bearing some relation to the papers on growing plants in charcoal, given in p. 152. 219. 221. and 252.

"On the probable Use of Coal-dust as a Manure. — The analogy of the constituent principles of coal to that of oil or animal matter led to the idea that it might probably be employed as food for plants; and, when I further reflected that many geologists supposed it to be of vegetable origin, I was strengthened in the opinion. Its destructive distillation, yielding olefiant gas, ammonia, tar, oil, &c., still more strongly corroborated the idea; and I was led to put it into practice and recommend it to others. I shall be very brief, and confine myself entirely to the results of my own observations, leaving

entirely and completely out of view the opinions and conclusions of others, some of which were favourable to the views I entertain.

“The complete insolubility of coal-dust seems to be the insuperable objection to its utility as a manure; but surely it is not more insoluble than the effete ashes.

“I am inclined to believe, from a long-continued series of observations, that the slender filamentous radicles of plants have a power in all respects equal, if not superior, to small electro-galvanic wires of low intensity, which, by slow continued action, decompose most substances that are presented to them, and, among others, that of coal-dust. Whatever the vital principle may be, we cannot assign it a lower grade in the scale than that of electro-galvanic influence; and we are not assuming too much for the vital action of the radicles when we claim for them a power equal only to that of small galvanic wires, which can and do effect a decomposition of coal-dust.

“A multitude of facts seem to confirm this idea; but it is not my intention to enter on this wide field, but simply to strengthen the proposition of coal-dust for manure by fair and rational statements. It is certain that substances regarded by us as nearly insoluble are absorbed into plants in large quantities. I have taken great pains, on a small scale, to demonstrate the fact, that coal-dust is *not inimical* to vegetation, by filling a series of garden-pots with fine coal-dust, and planting and sowing a variety of plants therein, as potatoes, onions, &c. &c. In all of them the vegetation was extremely vigorous and luxuriant. I have filled hyacinth-glasses with coal-dust, and put bulbs therein, supplying water as required; and the result, when compared with those without the coal-dust, was very marked and evident; large, healthy, strong plants being produced, and admired by many.

“I can only say, that those who will fill a box with coal-dust, and plant potatoes therein, will obtain a good and early crop, more bountiful and finer than when in common mould under similar circumstances.

“Strawberries, onions, and a vast variety of useful and ornamental plants, thrive extremely well indeed in coal-dust.

“Coal-dust is remarkably clean and neat, inoffensive, without odour or stain, not capable of harbouring insects or maggots, well adapted for in-door floriculture, and enduring for a long period, not consolidating or becoming too hard by frequent watering, and possessing many great advantages.

“As coal-dust is so insoluble, it must of necessity be very slow and gradual in its action, diffusing its influence over a long space of time, not coming into action quickly; and, independent of its insolubility, it has very little power of retaining moisture: hence, it is well adapted for those plants that like a light, loose, dry, and sandy soil, with the evident advantage of containing a very large amount of nutriment. Of course, coal-dust requires to be intimately mixed with the lower portion of the soil where the radicles extend, and then its beneficial action will be very perceptible on the crop of potatoes, peas, turnips, or cabbages; indeed, all evidence the fact of its being most useful. I could detail many experiments most satisfactory, but leave the subject with this communication, assuring your Society that truth, reason, and experience attest the fact to be as I state; and whoever will try it on a small scale, with the knowledge of its being a slow and steady manure of no mean power, will not be disappointed.

“But those who may be indisposed to adopt the use of coal-dust, may be induced to try a very excellent combination of coal tar and slacked lime.

“One gallon of coal-tar, mixed up well and completely with one bushel of slacked lime, produces a material of warmth and value as a manure; rich and stimulating, and tending very much to keep away the flies when sprinkled freely in and among the young turnips.

“I have used this compound with excellent effect on peas and potatoes, producing an evident and marked effect over the rows where none was used.

“Animal tar, or dippel oil, procured from the distillation of bones, and at present, I believe, a nuisance, if used with slacked lime in the same manner,

forms a much richer and more serviceable manure than that of the coal tar. And thus products of small importance, cheap and abundant, may be turned to good account in fertilising our soil.

“The Nitrates of potash, soda, ammonia, and lime, are all undoubtedly possessed of considerable efficacy as manures.

“The nitrate of lime is found in some old mortars; and both nitrate of ammonia and the nitrate of lime exist in the drainings and liquid of the dunghills, or muck-heaps; and to these, in some measure, is owing the highly fertilising power thereof. Nitrate of ammonia is a beautiful stimulant; and those who wish to excite the growth of favourite plants may water them with weak solutions, a dram to a pint of water, or use it in the hyacinth glasses in the same way as nitre has been used with such efficacy in quickening the growth.

*Oxide of Manganese* has been tried on many occasions: it readily admits of vegetation, and seems to possess the power of rousing and calling into action the dormant and languid vitality of old seeds. If mixed with the soil, it might yield oxygen to the plant, and absorb it again gradually from the air and moisture, so as to remain in the soil unimpaired for ages. It would appear to me to deserve a trial from the results I obtained with it.

“Whatever scepticism or ridicule coal-dust may meet with, I have the satisfaction of laying before your honourable Society a specimen, which, I trust, will meet with approbation, and to which, I believe, no valid or rational objection can be made; and the principle I deem to be one of considerable national importance. I allude to the combination of quicklime with sprats, fish, offal, refuse, blood, &c., and which might be used, in a commercial point of view, by the whalers and sealers using quicklime to preserve the flesh, and make it into a valuable manureal product, not to be despised in the absence of a better cargo.

“The Greenland whalers and the Newfoundland sealers, &c., would afford the means of enormous masses of animal matter being available for manure, the flesh being now thrown away in both cases.

“The specimen marked ‘Sprat-lime, No. 1,’ is a perfect chemical combination of sprats and lime:—3 parts by weight of sprats; 1 part by weight of good quicklime.

“The sprats are smashed or crushed by rollers into a complete pulp, and the whole mass of them carefully and intimately mixed with the quicklime by trituration. A considerable heat is produced, which tends greatly to the drying of the sprats; and some ammonia is evolved, especially if they are not fresh. In a few days the material is dry. It is necessary to bear in mind that no artificial heat should be employed, and that they should be turned over once a day.

“Sprat-lime approaches nearest in manureal properties to bone-dust. It is not liable to be attacked by worms or insects; does not come into rapid action at first; the sprats are economised and preserved, and their influence extended over a considerable time, supporting vegetation equably and well for several years, I presume. It is not destroyed by birds. The animal matter is not very soluble in sprat-lime; and it is, in well made specimens, in perfect chemical combination. The proportion of animal matter, or fish, must not be increased beyond that of three times the quantity of lime employed, otherwise it will be of a very inferior nature, and liable to decomposition.

“Lime may be regarded, in an agricultural point of view, as the salt of the earth, and the means of preserving all substances for manureal purposes.

“If two parts of fish and one of lime be used, it of course dries the quicker and faster; but, then, the bulk of the manure is increased and its value lessened by the diminution of the fish or animal matter. Three to one seem to be fair and good proportions. It is most important to bear in mind that quicklime is to be employed, and not slacked lime, on account of its already containing its definite quantity of water, and hence its value and efficacy are very much impaired.

"The specimen marked 'Sprats and Lime' was sprats put into quick-lime, alternate layers of each, the sprats not being broken. The worm and maggot attacked them; and this mode is inadequate to their perfect preservation.

"I have tried blood, flesh, and a variety of substances, such as the entrails and refuse of fish, which all produce useful and valuable fertilising manures. I appeal to your Society for a verdict, and I leave the subject in your hands; it being foreign to my purpose to pursue it any further. Convinced of their value and importance, I respectfully submit to your decision." (Vol. liii. p. 9.)

There is a paper "On the Amputation of the large Branches of Trees," with a view to prevent the stump from rotting. "The branch is cut off at a distance of 3 or 4 feet from the tree, care being taken to support it in a manner to prevent it from splintering the stump. The bark of the stump is then cut into narrow longitudinal strips, which, after being carefully peeled off with a barking tool, as far as the body of the tree, are tied back so as to keep them clear of the saw in the amputation of the stump close to the body of the tree. The saw-cut surface is then cut smooth with a wide mortise-chisel, and is covered with the strips of bark, cut and fitted to it as accurately as possible, and fastened down with brads driven in to the depth of about one eighth of an inch. The wound and surrounding parts are next covered, to the depth of 2 or 3 inches, with a cataplasm, according to the following receipt:—Clay, 4 parts; fresh cowdung, 2 parts; wood ashes finely sifted, 1 part." (p. 10.)

There are papers on the "Cultivation of Tea in Assam," a "Report on Tea from Brazil," and some other articles of more or less interest to the cultivator; but the parts are, as might be expected, chiefly occupied by discoveries and practical applications in chemistry, manufactures, and mechanics; the whole illustrated by well-executed engravings on copper and wood. In a word, these two parts ably sustain the long-established reputation of the Society, at once the parent and the model of so many others.

## MISCELLANEOUS INTELLIGENCE.

### ART. I. *General Notices.*

*VITALITY of the Genera Pirus and Crataegus.*—It is not, perhaps, so generally known as it ought to be, that most or all of the species of the above genera, when transplanted of considerable size, and with few fibrous roots, will sometimes remain a year in the ground without putting forth leaves, and yet do so abundantly the spring of the second year. We have observed this, many years ago, in the case of transplanting the stumps of large thorn hedges, and also, more recently, in the case of the mountain ash and *Pirus comūnis salicifolia*, and there are now examples of it in the case of fifteen or twenty species or varieties of thorns, standards, in Mr. Forrest's Nursery, Kensington. The fact is capable of useful application, more especially in transplanting large thorn hedges. — *Cond.*

*A Camera Lucida, well adapted for Gardeners,* has recently been invented by Sir John Robison, late Secretary to the Royal Society of Edinburgh, whose plant-case is described in our Vol. for 1840, p. 117. This camera is remarkably cheap, and easily constructed, and is peculiarly applicable to the delineation of flowers, fruits, bulbs, seeds, and other small objects. It was exhibited to the Edinburgh Society of Arts, on March 8. 1841, and there is an account of it in the *Mechanic's Magazine* for March 6., and in *Jameson's Journal* for April; and the following notice is compiled from the last two sources. "Something similar," Sir John Robison observes, "was suggested to me, some years since, by the Rev. Mr. Taylor of York, but it had escaped my memory until lately; when, looking at some plants confined in a frame of plate glass, I was struck with the vivid images of the plants reflected from

the bright plates, at such an angle as permitted vision of objects through them, this recalled Mr. Taylor's suggestion, and showed how it might be made available for copying natural flowers and other small objects."

"Fig. 44. represents a piece of thin plate-glass (A D E F), set upright on a drawing-board by means of a wooden standard (A B C), in a groove in which the edge of the plate is retained by the wedges G and H. The wooden standard is not fixed to the drawing-board, and may be set on it in any convenient position. To use this apparatus, it is placed in front of the artist,

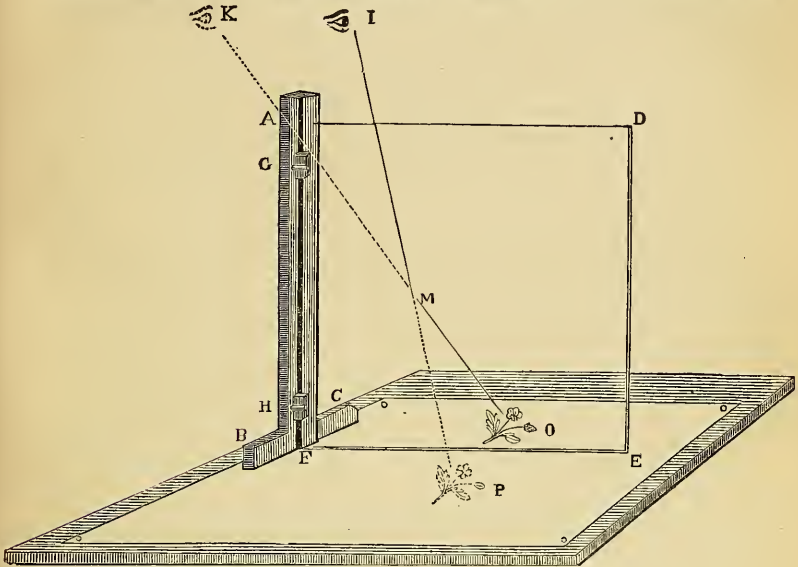

Fig. 44.

Camera lucida for Gardeners.

with the standard A B C towards him; the object to be copied is laid on the left-hand side of the plate, as at o; the head of the observer being also a little to the left of the pillar, and the eye directed towards the middle of the plate, as at M, a distinct image of the object o will be perceived, as if it lay on the paper at P; and as, at the same time, a pencil held on the right-hand side of the plate will be equally visible, it may be applied to trace the image at P.

"Some attention is required in selecting a favourable position for the apparatus, in respect to the illumination of the object, and its admitting only such a degree of light to the paper on the right-hand side of the glass, as may give sufficient distinctness to the point of the pencil, by which precaution the reflected image is seen to most advantage."

"It must be recollected, that the delineation will not represent the original object as beheld by direct vision by an eye placed at I, being that of a reflected image, similar to what would be seen by direct vision, if the eye had been situated at K." (*Mech. Mag.*, vol. xxxiv. p. 202.)

*Kyanised Timber.*—In a series of experiments carried on at Welbeck during the last four years, regarding the efficacy of kyanised timber for gardening purposes, we have not found it last longer, when exposed to great heat and moisture, than the unprepared. In 1838 His Grace the Duke of Portland first published the results of a trial in a Calcutta stove, the bottom-heat being supplied by steam, and the prepared and unprepared timber plunged in the tan, subjected to a heat of from 90° to 100° Fahrenheit; good Memel deal unprepared lasted longer than the best oak kyanised. The then managing

director of the Anti-Dry-Rot Company and Mr. Kyan came down to see and test the timber ; and, on their return, sent down from the Company's yard at Limehouse eight pieces, prepared and unprepared, to be plunged in the same stove. The results have been the same as on the first trial ; and the different kinds of prepared timber have decayed quite as fast as the unprepared. Good Baltic deal unprepared lasted longer than the best kyanised oak, owing, no doubt, to the resinous quality of the wood. We have tried kyanised timber in the mushroom shelves, and I am decidedly of opinion that it is prejudicial to their growth. In 1837, we tried, in the bottom of mushroom beds 1-inch Scotch fir deals, saturated in copperas and limewater ; it had the effect of preserving the timber for two years ; in the same place, when not saturated, it never lasted longer than one. Having seen the pernicious effects of timber kyanised in a large stove at Thoresby, the particulars of which were communicated to the conductor of the *Gardener's Magazine* by Earl Manvers, I am fully convinced it must be used in all horticultural erections with great caution. Another preparation, which is, I believe, of zinc, has been patented by Sir W. Burnett, and tried here, the particulars of which I will transcribe from my memorandum-book. " April 20. 1840 : Received from Sir W. Burnett, from the Admiralty, eight pieces of timber, four prepared and four unprepared, plunged in the bark-bed of new Calcutta stove ; likewise pieces of canvass, cloth, and cordage, prepared and unprepared, placed in a damp stokehole, amongst decaying vegetable substances. Sept. 28. 1840 : The unprepared pieces of canvass, cloth, and cordage, quite decayed ; the prepared sound. Jan. 20. 1841 : A piece of scarlet prepared cloth decayed ; the other cloth, canvass, and ropes, sound. The timber, prepared and unprepared, is now beginning to decay alike, and I have no doubt it will not last longer than Kyan's, under the same circumstances. Garden nets, rick cloths, and so on, dipped in Sir W. Burnett's preparation, according to the trial made, would last for a great many years, if taken care of and kept dry, when laid up for the season ; besides, it has not the poisonous qualities of Kyan's solution. (*W. Tillery, Welbeck ; in Gard. Chron.*, Feb. 20. p. 117.)

*Pocock's Asphalte Roofing* has been tried as a substitute for bast mats, straw mats, or boards, for covering frames or pits, in the Dalkeith Gardens, by Mr. M'Intosh. This material, which is composed of coarse waste felt saturated with asphalte, and powerfully compressed, is sold in plates, 16 in. by 32 in., and about the thickness of thin pasteboard, at 4½*d.* each. It weighs 60 lb. to the 100 square feet, and bears extreme heat and any degree of cold. It is formed into panels in wooden frames, and, of course, may be applied to all the different uses for which frames or shutters of boards are adapted. Mr. M'Intosh considers that it will be found much more efficient and economical than any other description of covering hitherto in use. (*Gard. Chron.*, Feb. 13. 1841, p. 100.) The asphalte roofing is sold in London, by Messrs. Pocock and Co., 61. Cheapside, from whom we have procured a specimen. The difficulty in using it, we find, will be its tendency to absorb moisture, and become depressed in the panels into which it is formed when used as protecting covers. When used as roofing, it is supported on a uniform surface of boards, which, of course, prevents it from sinking, so that the rain is thrown off almost as effectually as by slates. — *Cond.*

*Tarred Canvass for Coverings* to pits would be more convenient than patent asphalte roofing, as it might be nailed on the top edge of the pit, and made to roll up on a roller. By putting rails on the frame, the canvass would be a good protection for the glass, as well as leave a space for air between. If nailed to wooden frames, it would form screens useful for garden purposes, and is cheap. The canvass may be of any thickness, according to the purpose for which it is required. (*W. in Gard. Chron.*, March 13. p. 164.)

*To destroy Ants.*— Pour solution of chloride of lime round the roots of plants attacked by them, or lay the following mixture in their runs : " Take 2 oz. of fine bread crumbs, well dried, and rubbed very small ; 2 oz. of loaf sugar, well pounded and made very fine ; and 1 oz. of levigated mercury : mix



the whole well together on a sheet of paper, and then put it into a bottle, or other convenient place, which must be kept very dry." By laying small portions of the mixture in the runs of the insects near their nests every day for a short period, an effectual clearance will soon be obtained. (*Gard. Chron.*, Jan. 16. p. 37.)

*Woodlice*.—By the following very simple method, frames and pits might be kept comparatively free from woodlice; at any rate the insects might be so far subdued by it as not to be injurious to plants. Put a cold boiled or roasted potato into a small flower-pot, cover the potato with moss, leaving a little hanging out of the pot, by way of enticing the insects to enter; then lay the pot on its side in a corner of the frame. Woodlice feed in darkness, and at the approach of day they escape to their hiding places, in cracks and crevices, or amongst the loose soil or bark; the moss is, therefore, necessary to induce them to remain in the pot, to which they will flock in hundreds after having once tasted the potato. Every morning the pots should be taken out of the pits and the insects destroyed; the same bait will serve for a week or longer. If properly attended to, half a dozen pots so prepared will soon clear a frame of this troublesome insect. (*J. B. Whiting*, in *Gard. Chron.* March 6. p. 150.)

*Mr. Green's Cucumber Pit*.—The construction of the pit is as follows: the walls are built of 9-inch brickwork, 5 ft. in the back, and  $2\frac{1}{2}$  in the front, and 5 ft. wide in the clear, 36 ft. long, covered with nine lights, and divided into three compartments. A trough of brickwork is carried along the bottom from end to end in the centre; this is constructed by first laying two bricks thick, 1 ft. wide, and then forming the two sides of the trough with bricks on edge, the whole being so cemented as to hold water. The pit is heated with hot water by means of a branch of  $2\frac{1}{2}$ -inch pipes proceeding from the boiler which heats a stove at a short distance. The hot water flows along the back and front of the pit, but the return pipes are placed in the trough first described, which is filled with water, or partly so, as circumstances may require, by means of a small pipe that leads to the outside. Another small pipe is laid in the bottom of the trough for letting off the stagnant water, and for emptying it occasionally; for in very dark damp weather a drier heat is required. The advantages gained by this pit, over anything that I have ever seen or heard of, are: 1st, a great saving of labour and dung, which last at all times makes a very littery and unsightly appearance; 2d, the having a sufficient command of heat in severe and changeable weather; and 3dly, the return-pipe, being buried or partly buried in water, gives, when required, a sufficient bottom-heat, and the constant vapour arising from it renders the plant so healthy and strong that a good crop of fine fruit is certain. (*Gard. Chron.*, Jan. 16. p. 36.)

*Agriculture*, under the monopoly system, is a wholesale manufactory of high rents and pauperism. That the repeal of the corn laws, which would mitigate the pauperism, would also destroy the rent, is an illogical conclusion. Thriving trade, increasing towns, and railway communication, are surer and more enduring raisers of rent than the strictest monopoly that can be conceived; and they enhance rent without the accompaniments of bitter alienation, famishing families, destructive riots, midnight incendiarism, and the curses of plundered poverty that ascend to heaven. (*Morn. Chron.*, Jan. 12. 1841.)

*Moss on Gravel Walks*.—A shaded gravel walk in Professor Henslow's garden, at Cambridge, was always covered with a mat of moss, and became perfectly green in the autumnal months. Mr. Henslow watered it in parallel and transverse strips with solutions of different salts, to see whether any of them would destroy the moss, and prevent its growing again. Several appeared to kill the moss, which, however, was replaced, in most cases, in a very short time. He notices "three of the solutions as having produced more permanent effects; these were, corrosive sublimate, sulphate of iron (green vitriol), and sulphate of copper (blue vitriol). The first two seemed to kill the moss immediately, but they also turned it black; and at the expiration of

a year it was still adhering to the surface of the gravel, black instead of green. But the effect produced by the sulphate of copper was remarkable. The moss entirely disappeared ; and at the end of the year, when the rest of the walk was again completely carpeted, the strip which had been watered with this solution was perfectly bare." (*Gard. Chron.*, Jan. 16. p. 36.)

*Road-making.*— In some towns of Belgium, Campeachy and Pernambuco woods are used for roads after the dye is extracted, and they are reduced to small pieces. They are admirably adapted to garden-walks, giving them the softness, elasticity, and warmth of a carpet. (*Gard. Chron.*, Jan. 30. p. 71.) Spent tan is frequently used for the same purpose in Belgium.

---

## ART. II. *Domestic Notices.*

### ENGLAND.

*PARKS and Pleasure-Grounds.*— In the *Westminster Review* for April, there is a very interesting article with the above title, to which we wish to direct the attention, not only of gardeners, but of the inhabitants of towns and cities. The object of the article is to procure parks and pleasure-grounds for the working classes, and to show the progress that has been made in attaining this object during the last five years.

"Public opinion is gradually awakening to a sense of the importance of open spaces for air and exercise, as a necessary sanatory provision, for the inhabitants of all large towns. Some little sympathy, too, is beginning to be felt for those who have hitherto suffered almost a total privation of every innocent pleasurable excitement, and a desire exists, or is at least professed, in influential quarters, to extend the rational enjoyments of the working classes. It is five years since Mr. Buckingham, member for Sheffield, moved in the House of Commons that the inhabitants of large towns should be empowered to rate themselves for the purpose of providing public gardens, or open spaces, for the healthful recreation of the class now pent up in courts and alleys, or confined to crowded streets. It is well known that on the Continent similar powers have been long intrusted to the municipalities of towns. In the suburbs of many of the cities of Germany and Holland where fortifications once existed, the walls have been demolished, the ditches filled up, and beds of flowers, shrubberies, and broad gravel walks formed instead ; where, in summer time, the whole population may often be seen enjoying the pleasure of an evening promenade. In free England, it was proposed that the inhabitants of our towns should be permitted to tax themselves, if they thought proper, to the extent of the funds necessary for a similar object ; and a ministry, and a majority in parliament, resisted the proposition ; and to this day powers which might have been claimed as rights have been withheld from all the municipal councils of Great Britain and Ireland. In 1837, Mr. Hume succeeded in carrying a resolution, as one of the standing orders of the House, that in all new enclosure bills some portion of the waste lands about to be appropriated should be set apart for the healthful recreation of the inhabitants of the neighbouring towns or villages. Since the resolution was adopted by the House, sixty-three enclosure bills have passed into law, and several hundred acres of land, which would otherwise have become private property, have been secured to the public. This is an admirable beginning, but one which may be regarded rather as a preventive of future evils (arising from an increasing and too crowded population) than a cure for those which have long existed. The pale and sickly inhabitants of towns see nothing but brick walls stretching farther and farther in every direction around them, green fields becoming brick-fields, pleasant hedge-paths converted into long lines of streets, and every opening closed, or closing, from which a glimpse of nature could once be obtained. How many thousands of those who, once or twice in the year, visit St. James's and Hyde Park on Sundays are deterred, by a weary walk of three or five miles, from habitually enjoying a privilege designed chiefly for the

inhabitants of the west end, many of whom have parks of their own. It is to Mr. Hume we are also principally indebted for preserving Primrose Hill from the grasp of private speculators. He successfully resisted the project of converting this favourite resort of Londoners into a private cemetery, and was the means of inducing Government to purchase the property from Eton College and Lord Southampton ; a purchase which has recently been effected, to the extent of fifty-eight acres, for the benefit of the public, at a cost of 300*l.* per acre. This is a most gratifying fact. But still it is in the Borough, and at the east rather than at the west end of London, that open spaces for healthful recreation are most needed. Another pleasing circumstance is, that benevolent, public-spirited, and wealthy individuals are beginning to be interested in the same object. We esteem those who, with excellent, but often erring intentions, have founded charitable societies for the relief of suffering ; but greater honour to those who look beyond the palliatives that may alleviate or remove distress, and think how the happiness and best interests of the operative are to be promoted ! Give us for reformers men who have honest sympathies with the class of whose cause in parliament or public meetings they profess to be the advocates. Among those who assume the name are some who enclose immense possessions with walls and gates, and employ keepers with guns to guard every avenue to the vast solitudes by which they choose to be surrounded. Let such men pitch their tents in the deserts of Sahara, or the wild prairies of America. What business have they here, in the midst of a civilised community, linked together by chains of mutual obligation and dependence ? It is pleasant to dwell upon the contrast afforded by the conduct of one individual, Mr. Strutt, to the selfishness of the class to which we have alluded. His late gift to the town of Derby is one of the noblest benefactions of modern times ; one which we delight to notice, because it has no tendency to frustrate the lessons of forethought and self-dependence which nature teaches, to pauperise industry, or make the poor man trust to the bounty of the rich, instead of the energies which an honest pride would raise within him. Were one general system adopted with all the public parks and gardens in the vicinity of London, such is their variety of soil and aspect, that they might be made to exhibit fine specimens of all the different kinds of trees and shrubs which will grow in the climate of Middlesex. If these were conspicuously named in such parts of the parks and gardens as were destined for pedestrians, the names and the plants would tend to amuse and instruct every class of the population, as in the case of the Derby Arboretum. The late Duke of Baden, though in many respects a great tyrant, yet kept, all the summer, an excellent band of music perambulating in the public park and gardens at Carlsruhe, from two o'clock in the afternoon till dusk. To these gardens all the inhabitants of Carlsruhe had access at all times. The effect of the music among the trees, a sudden burst coming sometimes in one direction and then in another, sometimes close at hand and again at a distance, was quite enchanting, and may, perhaps, have had some effect in giving a peculiarly mild and gentle character to the inhabitants of Carlsruhe. If the metropolis and its suburbs were put under the management of a council, or commission like that which exists in Paris and Munich, a general reformation of all the public gardens, and a general superintendence of all new streets, would be one of the duties of such commission, and an annual metropolitan rate of a halfpenny in the pound would raise a fund sufficient to render London a model for European capitals." (*Westminster Review*, April, 1841.)

The Bath Royal Horticultural and Botanical Society has (on April 10.) presented its late curator, Mr. W. H. Baxter, with a handsome silver cup, bearing the following inscription :— "Presented by the Committee of the Bath Royal Horticultural and Botanical Society to W. H. Baxter, as a testimony of their approbation of his conduct during the time he acted as their Curator."

Mr. Baxter, most of our readers are aware, is the son of the much respected curator of the Botanic Garden, Oxford. He compiled, under our

direction, the last Supplement to the *Hortus Britannicus*, and the forthcoming Supplement to the *Encyclopædia of Plants*; and we can, from these and other circumstances, most strongly recommend him as peculiarly well adapted for being the curator of a botanic and horticultural garden. We trust some good appointment of this sort will be his lot at no distant period. — *Cond.*

#### IRELAND.

*Botanic Garden, Glasnevin, Dublin, March 17, 1841.*— From the unremitting interest you take in behalf of young gardeners, and the many persuasive arguments you have from time to time published, with a view of encouraging them to mental improvement, I feel convinced, you will be gratified to find that others of a kindred spirit are not wanting, who most liberally contribute to the means for obtaining so desirable an object. The following books were lately bequeathed by the late Mr. Robertson, nurseryman, Kilkenny, in trust to the Royal Dublin Society, for the use of the professors, curators, subcurators, and pupils in the Glasnevin Botanic Garden, where the library is desired to be placed, and in such a way as it can be made available to all concerned.

These books, to such an establishment as this, will be of the very greatest value to it; because there are constantly from eight to ten young men employed, who generally come from the country, and remain a term of two years in the Society's gardens, after which they go out to make way for others. During that period they are regularly put through all the departments in the garden, and afforded an opportunity of annually attending a course of botanical lectures. Hitherto the want of a garden library, where the young men could read in the evenings, has been very much felt; but now, since the books are supplied by the liberality of Mr. Robertson, there can be no doubt of the Society making any further arrangements which may appear necessary for carrying out Mr. Robertson's intentions. — *D. Moore.*

Mr. Robertson, F.H.S., died in August, 1839, and a short notice of the circumstance will be found in our obituary for that year (p. 584.) We have not given a list of the books, which amount to upwards of 420 volumes of gardening and botanical publications, mostly published since the commencement of the present century, and including all that have, during that period, been, either in France or England, considered the most valuable. We deeply regret to learn that, since the donation was received, the Irish Government has refused to continue the annual grant to the Dublin Society; but surely such a refusal cannot be persisted in, since, if there were nothing more to result from it than the ruin of this garden, the loss to Ireland would be very great indeed. — *Cond.*

"It would appear, from a circular issued by the Lord-Lieutenant, that, though His Lordship declines recommending the usual parliamentary grant of 5,300*l.* per annum, it is competent for the commission to report in favour of continuing it to the Dublin Society, should they think that the public would be benefited by so doing." (*Times*, April 9, 1841.)

---

#### ART. III. *Retrospective Criticism.*

*COMPARATIVE Temperature of different Years.* (p. 235.)— Your correspondent N. remarks on my paper upon the equality of temperature, that the average temperature is found to vary as much as 5°, therefore, I beg to inform him that I took as my authority Professor Whewell. In his *Bridgewater Treatise*, he states that the average temperature is about 50·4; that the year 1788 was so severe that the Thames was passable on the ice, and the mean temperature 50·6, being within a small fraction of a degree of the standard. In 1796, when the greatest cold ever known in London occurred, the mean was 50·1, which is likewise within a small fraction of the standard. In 1813–14, the average temperature was 49°, being little more than a degree below the

standard; and, in 1808, when the temperature in London was  $93^{\circ}5'$ , the average was only  $50^{\circ}5'$ . Therefore, taking these as facts, and considering the almost impossibility of ascertaining the exact temperature during a year, I, as already stated, considered that, for every practical purpose, it is sufficiently accurate to assume they are invariably alike; and, as every created thing bears the indelible stamp of design in its creation, it seems unlikely any thing so truly important should be left to chance. Now, these statements are either founded in error, the years sadly changed, or N. mistaken; and, until I am better informed, I must consider the latter to be the case. But I should like to see the correctness of the statement discussed by those able to do so. It seems to me surprising that instruments better calculated to ascertain the temperature have not been produced, as a thermometer that would register the temperature of every hour might easily be invented. N. differs from me also upon acclimatising plants. He considers their nature immutable, yet he overthrows the proposition by stating that in successive generations we can do a little; but grant that the progeny of a plant can be rendered more hardy than its parent, and the same rule must be applicable *ad infinitum*.—*N. M. T. Folkestone, April 3: 1841.*

*Mr. Penn's Mode of Heating and Ventilating.* (p. 232.)—It appears to me that G. C., in noticing Mr. Penn's mode of heating, has gone rather too far, and admitted a little more of the truth than he intended. The upward air, he says, amounted to an agitating current. Without a downward current, how was the upward one supplied? This unhappy admission of fact has established what he so anxiously wished to disprove. Next time he catches a frosty day let him hold a lighted candle in the drains, and he will be convinced there are more currents than the upright ones.—*N. M. T. April 7. 1841.*

*Mr. Forsyth's Plant Structures.*—Mr. Forsyth, in p. 204., refers with much seeming satisfaction to the gloomy structures he has recommended (Vol. XIII. p. 62.) for the culture of plants, which reminds me that I intended entering my protest against all such pseudo-economical structures, and cautioning the inexperienced against erecting them, as the result must be inevitable disappointment. I am now, despite of previous prepossessions to the contrary, convinced that they are altogether unfit for the purpose of exotic culture during the months of winter. The inelegant appearance of the houses recommended in Vol. XIII. p. 204. would deter most people from erecting them, were they not held forth as economical; but a trial will prove this to be an utter fallacy, as I calculate they require at least one third more fire than houses having front or upright glass, upon which the sun can act at a season when his oblique rays are utterly powerless upon houses without it. At a time, too, when the influence of light is universally known to be indispensable to the progress of vegetation, it seems incredible that any one should so far expose himself as to advocate structures that go so far to exclude it. Light is, in fact, the only difference in artificial climates between summer and winter, and the progress made by vegetation is in proportion to its intensity, showing it to be an essential which no artifice can supply; consequently, a house constructed to admit a single ray more than another is the more perfect, and *vice versa*. Mr. Forsyth commiserates the amateur who possesses detached houses with glazed ends, glass doors, partitions, &c.; still these houses, shed-like though they be (but appearance can have no effect upon the man who admires brick fronts, brick ends, and brick partitions), yield to none in their fitness for the culture of plants. Being detached, enhances their real value, as they enjoy several hours more direct sun than they otherwise would, and the advantage of this, economy apart, will not be denied by any who admit the powerful agency of light. Such structures would be considered more perfect by the "ridiculous foolery of glazing the dead north wall," p. 204., as this would put plants in the position assigned them by the hand of the "Glorious Architect Divine;" placed, as it were, in a centre of light, without which they are apt to become, like Mr. Forsyth's structures, terribly one-sided; and, however contemptible he may deem the pale blue rays of the north, still, when

directly admitted, they do much towards keeping plants in health, as may be seen in houses so constructed.

It is the allowing a free ingress of light on all sides, the presenting a direct surface to the sun, and the absence of all shade that renders the hand-glass so well calculated to conserve or grow plants; and it is the very reverse of all this that will render the substitute he proposes a sorry one. It can be said to present no direct surface where light is a desideratum; it will at all times shade, consequently render cold and damp a space equal to what it covers, and this to the greatest extent when these things are most to be avoided. The proposed substitutes are, in fact, so many small frames, and the superiority of plants wintered in hand-glasses, over those wintered in frames, is known to every one. The calm Christian-like manner in which he proposes depositing himself in heaven when all these petty cares are o'er, has my hearty concurrence; and, without hastening his transit thither, I do hope he may long be anchored there before plants are immured in the paradise he bespeaks for them.—*N. M. T. Folkestone, April 7. 1841.*

Many of Mr. Forsyth's remarks are in such direct opposition to what you deem good taste, that I have often wondered you have not pointed them out. Many suppose all printed in the Magazine as meeting your approbation.—*N. M. T.*

After mature consideration, and the experience of many years, we deem it best for the good of our readers to avoid, in most cases, giving our own opinion: first, because we may be wrong; and secondly, because, whether right or wrong, such a system on the part of an editor has a tendency to check discussion. The mere knowledge of truth is not sufficient to fortify the mind against error. To make any truth our own, we must have sought it out from among errors and falsehoods. By repeated discussion, truths become impressed on the mind, which, if laid down as laws or facts, would have no effect whatever. The first step towards enlightening any man in a branch of knowledge in which he is deficient is to argue on what he already knows; not to lay before him the naked truth of the case, which he might neither understand nor be able to apply. Knowledge, therefore, among gardeners, as among every other class of society, can only be infused slowly and by degrees; and the great use of the *Gardener's Magazine* is, that every one can ask according to his wants, and that every one can receive supplies according to his capacity for receiving and making use of them. Though all articles, therefore, which appear in this Magazine do not, as *N. M. T.* says "many suppose," meet our approbation from the particular views which they take of the subject on which they treat, yet all which we insert do so with a view to useful discussion. That knowledge on any subject is very little to be depended on which is limited to one side of the question, even if that side should be the right one.—*Cond.*

---

#### ART. IV. *Queries and Answers.*

*PREVENTING Hares and Rabbits from injuring the Bark of Trees.* (p. 96.)—About seven years ago, I was much annoyed at the barking of some young dwarf apple trees by hares and rabbits, from which they were unprotected. Aware that these animals were rather particular in their feeding, I had some old cowdung collected, put into pails, and mixed with water to the consistency of thick paint; and this substance was laid upon the stems and branches of the trees, with a large painter's brush, as far as it was thought the hares could reach. I had the satisfaction of finding they never were touched afterwards, and the application remained on without renewing for several years. I have no doubt it would be equally useful for forest trees.—*Peter Kendall. Gifford's Hall, Stoke by Naigland, April 13. 1841.*

---

THE  
GARDENER'S MAGAZINE,  
JUNE, 1841.

---

ORIGINAL COMMUNICATIONS.

ART. I. *A Gardening Visit to Paris, from June 28. to August 16.*  
1840. By the CONDUCTOR.

(Continued from p. 204.)

THE preceding portion of our tour, as well as that which follows, was written shortly after our return from France, and both are published exactly as they were written. Had this not been the case, we should have been tempted to introduce some remarks on the recent scheme for fortifying Paris; a scheme which we deeply regret, as sinking an immense amount of capital, which we cannot help thinking would have been much better employed in the formation of roads, railroads, and other territorial improvements. It is singular that while Paris is being fortified, the walls of Potsdam are being levelled with the ground, and those of Berlin are expected soon to follow.

*London to Brighton.*—*June 29.* Within ten or twelve miles of Brighton we observed a small villa, in which all the trees were spurred in, and furnished with short branches from the ground to the top; thus giving every tree more or less the form of a cypress or Lombardy poplar, but with a considerable difference in the colour and character of the surface of the foliage. The effect was singular, and such as by contrast would produce a striking appearance in the grounds of a small villa formed in the bosom of an extensive natural forest.

*Dieppe.*—*July 1, 2.* Footways of asphalte are formed in the principal streets, so as to add wonderfully to the comfort of pedestrians. When these footpaths cross carriage entrances, they do not terminate in kerbstones and steps, as is generally the case in Britain, but in inclined planes, which prevent all risk of stumbling, and are the more necessary in Dieppe, as these carriage entrances to courts are of frequent occurrence. The greater part of the town is laid out in a regular manner, with the houses all of the same height, and with the same elevation; the town having been burnt down in time of war, and rebuilt by the government on one general plan. The external elevations

indicate a certain degree of attention to design and effect; the system being one of vertical supports or pilasters to a frieze and cornice, which run from one end of the street to the other. The windows are between the pilasters, against which abut their flat slightly arched heads. On the whole, it is satisfactory in these elevations to trace the appearance of design, notwithstanding the sameness produced by continual repetition. The public baths, erected from the designs of M. Dupont, a resident architect, with whom we had the pleasure of becoming acquainted, exhibit a long-extended elevation, well adapted for the site. In front are some trees and shrubs planted among sand and grass, and treated (or rather neglected) in a manner which must ever prevent them from growing vigorously. At a short distance, a plantation of standard roses and dahlias shows what may be produced in the locality with a little care. Among the flowers in the shop windows, tree mignonette, twenty years ago so common about London, is frequently met with; as well as some of the new annuals, such as *Clárkia pulchélla*. There is much curious architecture within and without the cathedral; but we shall only notice the kind of chair (*fig. 45.*) used here and at Rouen in the churches, which has two bottoms; an upper one for sitting on, and a lower one for kneeling on, the upper one being turned up so as to form a resting-place for the elbows or head. The joint is formed by a pin working in a projection from the back style of the chair. To keep the upper seat perfectly steady, the lower part of the front style drops into a socket in the upper part of the lower front style. We have here given an engraving of the chair, and also of another in page 298.; because we think they are, with some modification, well adapted for public gardens; the low seats being convenient for children.

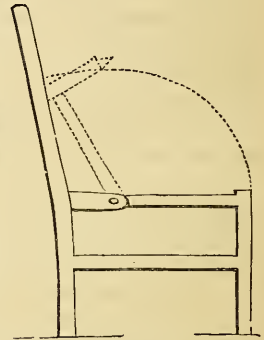

Fig. 45. Chair adapted for Public Gardens or Pleasure-Grounds.

There are no sewers in Dieppe, which was assigned to us as the reason why there are no water-closets. Sewers, it is said, are objected to on account of the expense; and hence what would form their contents is conveyed away in the gutters, on the surface of the streets. In some of the back streets, these gutters are so wide as to expose a large surface of watery material to evaporation, and hence the smell in warm weather is most disagreeable and unwholesome. To complete the arrangements for the health of the town, either sewers should be formed, or perpetual currents of fresh water should be made to run through



the gutters of all the back streets. The contents of the main sewers should be filtered by being passed through gratings at the points where they enter the sea, which would intercept more bulky or light floating impurities, and furnish some manure. The liquid would still be unwholesome, but it would be in a state to be immediately diluted with sea-water to such an extent as to take away all its noxious qualities, with reference to deposition or evaporation. The surface gutters at present empty themselves into the river, in consequence of which its bed is muddy and disfigured when the tide is low; but were the contents of the sewers filtered, even if they did not empty themselves into the sea, this could not be the case. We stopped at the Hôtel de l'Europe, a French house, at once comfortable and economical.

*Dieppe to Rouen.*—*July 3.* The delight which we experienced on the first appearance of the clipped arbours and arcades of trees, after leaving the town, can be accounted for, partly from the effects of change of air, and partly from the love of the past combined with the love of novelty; this kind of villa being at once old in its style as well as in reality, and new to us from the rarity, or almost total absence, of such villas in England. Addison speaks of the powerful effect of things at once new and strange; and we might here enlarge on the sentiment produced by things old, and at the same time new.

The large proportions of the doors and windows in these villas, and, as a consequence of this, the smallness of the number of windows, and the absence of bold projections and recesses, (not to mention the arched window-heads, upright central divisions, the windows opening like doors, and large panes of glass,) show at once a marked difference between French and English villa dwellings. There is something grand in the large proportions; but the sameness in size and distribution of the windows does not, to an Englishman, give the same ideas of accommodation and comfort in the interior which windows of different sizes on different floors, and large projections do. We like to see, in a country house, a decided entrance portico, or porch, in some conspicuous part of the elevation; next, to be able to determine by the size and disposition of the windows, whether the principal living-rooms are on the ground floor or the floor above. We do not expect to be able to discover the windows of the drawingroom in the entrance front, but most certainly we do so in the garden front; and the smaller windows in the second and third story always indicate the dressing-rooms and bed-rooms. Very little of this is to be distinguished in the exterior of a French villa, at least in those of the last century; in England, the living-rooms and the sleeping-

rooms can generally be recognised externally in all well designed houses.

Between Dieppe and Rouen the greatest care is taken in planting and protecting the road-side trees. They are always planted on little hills, the stems protected by thorny branches, tied close round them, as in the Regent's Park, or by being wound round with straw ropes, from the ground to the height of 7 or 8 feet. These straw ropes, by preventing excessive evaporation from the bark, must be useful to the tree the first and second year after planting; and, accordingly, the practice is frequently adopted with standard fruit trees in gardens in France and Holland, and formerly also in Scotland, which took its gardening from these countries. The kinds of trees planted along the road are principally apples; those in plantations, almost every where, beech, on account of the peculiar value of that timber as fuel; and also because the beech is found to thrive in this part of France better than any other tree. The cottages by the road side are of two kinds: mud huts thatched, with little appearance of comfort; and brick or stone buildings, with the same class of accommodation as the mud huts, and characterised by red brick coins and facings to the windows, and tiled roofs. The cottage gardens were in general well cultivated; and in the neighbourhood of the manufactories, which occurred at several places on this road, they were stocked with flowers and shrubs, many of which were of new kinds. Here, also, are some villas, probably belonging to English manufacturers, in which English gardening is imitated with considerable success. In one we observed the effect of masses produced by an aggregation of small groups and single trees, a mode of arrangement which it is extremely difficult to get persons to understand and act upon in England; the objections being that trees grow faster in clumps, and that the expense of enclosing and protecting small groups and single trees is greater than in protecting the same trees in masses. We have shown the fallacy of both these arguments, in our suggestions for the improvement of Kensington Gardens, in Vol. XIII. p. 150.—157.

*Rouen.* — July 4—7. *The Botanic Garden* has been removed to a new site, which was formerly occupied by Calvert as a nursery; and it now contains upwards of twenty acres. The arrangement, or *école*, is on a piece of level ground in the centre of the garden, in beds of 5 ft. wide, with paths between them of 3 ft. 6 in. in width. There are two rows of plants in each bed, and the classification is that of Jussieu, as modified by the late Professor Marquis, which is also that followed in the *Botanique appliqué* of the present Professor Pouchet. We examined every tree and shrub in the collection, which is sufficient for a provincial garden. The names of a number of the species are different

from those adopted by us in the *Arboretum Britannicum*, but we had not time to make a list. The surrounding part of the garden is not yet completed, or, rather, is only commenced. There is to be a department for horticulture, including a collection of fruit trees; and an arboretum et fruticetum is to be distributed round the whole. The fruit-wall is already formed, and planted with peaches, nectarines, and apricots, all on little hills. The larva of the cockchafer is here so extraordinarily troublesome, that in front of the peach trees, about 2 ft. from their roots, rows of cabbage lettuces are planted to attract the larva; and, as soon as any lettuce begins to wither, the worm at its root is sought for and killed. Some hothouses are already erected, and heated by hot water in Kewley's manner. To shelter this garden, a row of handsome plants, 15 ft. high, of *Quercus pedunculata fastigiata*, is planted; a tree which, it is much to be regretted, is quite neglected in England. It might be had by hundreds from the Parisian or Lyons nurserymen, or from Bollwyller, or Tarascon, or Metz; and there are, we believe, plenty of plants of it at Sawbridgeworth. The finished parts of the garden were in excellent order, and did the highest credit to M. Dubreuil, the director.

*The Cemetery*, which was just commenced when we were here in 1828, and was then a naked hill, without a single tree or building, is now intersected by avenues, chiefly of spruce fir, but partly also of Scotch pine and silver fir; and there is one avenue of *Pópulus álba*. A considerable number of very handsome tombs have been erected, and there is scarcely one of these of which it can be said that it is not in good taste. It is the best school for this department of architecture that we know of, and is highly creditable to the taste of the wealthy classes of Rouen. We can only account for this from the general intelligence which prevails among the wealthy classes, almost all engaged in commerce, manufactures, or the law, and from the necessity of every one who would bury here purchasing the ground. The ground belongs to the town, and is sold at a fixed rate per square foot (about ten francs), without reference to situation. At the entrance to the cemetery there is a garden, with greenhouses, frames, and pits, kept by the curator, for raising ornamental plants, in pots, to decorate the tombs of such as are willing to pay for this peculiar luxury. Some of the tombs are constantly ornamented, during summer, with 200 or 300 pots of greenhouse plants, others with two or three dozen, some with only one or two, some with a nosegay in water, some with a wreath of gnaphaliums, helichrysums, &c. (immortelles); and some, which we think the best taste of all, are without any thing. The grave of that excellent man, M. l'Abbé Gossier, which is not yet furnished with a tomb, had a pot plunged in the mound

of earth, which, our guide told us, when placed there by a friend of the abbé, contained Duc van Thol tulips. A biographical notice of M. Gossier, of whose beautiful garden, mentioned in one of our early volumes, we have a plan ready to engrave, has been kindly promised us by Professor Pouchet. The abbé had a handsome fortune, half of which he left to public institutions in Rouen, and his excellent library to one of the schools.

*The principal Improvements* that have taken place at Rouen, since we last saw it, have been made along the quays, and consist of a suspension-bridge, the completion of a stone bridge, and the line of buildings, public and private, in very good taste. The streets in the interior of the town have not yet had footpaths of asphalte laid down, an improvement much wanted, on account of their narrowness and the roughness of the pavement. Nevertheless, there are some very remarkable improvements; such as the formation of a spire to the cathedral, including a staircase within, both entirely of openwork of cast iron; and the Hôtel de Ville is improving in what may be called the Municipal Gothic style. In this building, suspended against the wall of the grand staircase, is a brass plate, the inscription on which recalled to mind our favourite idea of the ultimate prevalence of the same weights, measures, money, laws, and language: it was dated 19th Brumaire, an 8, and signed *Liberté et Egalité*. We observed in one part of the town a contrivance for preventing bad smells from arising from aquariums, which is worthy of imitation in towns in similar climates to those of Rouen and Paris, viz. a copper tube, placed in the back part of the aquarium, pierced with holes, from which there is a continual flow of water. We observed, also, portable wooden aquariums, formed of staves, like casks, and placed in the angles of buildings, by which the fluid is preserved for manure; but these, we think, would be improved by a wooden screen placed before each, open at the two sides; which would also be a great improvement in the aquariums formed on the Boulevards in Paris. The broad gutters in the streets in the interior part of Rouen are not so injurious as the broad gutters in Dieppe, on account of the much greater steepness of the former town; but, nevertheless, every thing ought to be attempted by the authorities which has a tendency to narrow the evaporating surface.

*Rouen to Paris.*—*July 8.* Went on board the steam-boat at  $\frac{1}{2}$  past 4 o'clock in the morning, and arrived at Pecq, near St. Germain, at 5 o'clock in the afternoon. The banks of the river are varied and agreeable, one being higher than the other, and there are 300 islands. The high bank, being chiefly chalk or limestone hills, has a tame character as compared with the lower part of the Rhine, and some parts of the Rhône between Lyons and Avignon. There are a number of suspension and other bridges,

which have every appearance of being most scientifically constructed: but in the cases of the suspension-bridges, not only in this part of the Seine but in and about Paris, and from Paris to Thomery, we did not observe one where the supports to the suspending chains were in good taste; or, in other words, in good architectural developement. They are generally arches of masonry; and the chains, or wire cables, pass through holes in the upper parts of these arches, which holes appear to have been made after the work was completed with the intention of supporting something else. There is not even the trouble taken of putting a facing, or frame, round the hole, to show that it is a hole made purposely for some object. Sometimes this hole passes under the frieze, and sometimes through it, and occasionally it passes over the cornice; but always in such a way as to appear an afterthought, and by no means artistically united or connected with the support, or as a developement of what is below. In the central supports of the suspension bridge at Rouen, cast-iron Grecian columns are employed, which shows great poverty of invention; and in other situations, at Rouen and Paris, obelisks are used, with the holes bored through the apex. To render these supports what they ought to be, an engineer must arise, who to the science of engineering adds a genius for artistical composition. Old architectural associations must be neglected, and the foundation laid for new associations, founded in truth and usefulness; on cast iron, and the various purposes for which it is now employed.

The views of the banks of the river are, to us, pleasing in themselves, and from their being different from any thing of the kind which occurs in Britain. They are pleasing, also, because, from time to time, we pass a large manufacturing town, and because, between these towns, the soil is occupied by innumerable small proprietors (their stone-built cottages generally near the water's edge); who, though they live a life of toil, are yet perfectly independent, having all the resources of a good soil, a favourable climate, and a river which supplies them with fish for the trouble of fishing. With the resources of the river and the soil, it does not seem possible that persons so circumstanced can ever come to want; but whether, with the necessity which must exist for every part of the family to work hard in operations all more or less laborious, there can be much time for reading is doubtful; and, without being able to spend some portion of every day in reading, we cannot conceive the existence of much refined enjoyment. Had this idea not intruded itself, we should have been tempted to envy the condition of these apparently happy people; though we have no doubt it will be alleged that we viewed them *couleur de rose*. The general want of instruction among this class of society in France renders it impossible that

there should at present be any taste for reading among the poorest class; but the time may come, and we hope will come, not only in France but in every country, when reading will be considered as a necessary of life; and then, and not till then, will the wages of common country labourers be such as to admit of their indulging in this enjoyment. The condition of small proprietors of this kind has, within the present century, been much improved by the general culture of the potato, by which a greater quantity of food is raised with less labour; and it is beginning to be still further ameliorated by the low price of manufactured cottons and linens, which, by rendering the growth of flax, and, consequently, spinning at home, unnecessary, lessens the labour of the women. On the supposition, then, that the small proprietor is not burthened with a large family, that he and his wife have been educated, and both experience the pleasure of reading, and that they also take an interest in the politics of their country (which, in our opinion, is an essential ingredient to the dignity and happiness of man), we can conceive them to be tolerably happy. Others, however, see things in quite a different light, and deprecate this division and subdivision of property.\*

\* The following observations on this subject by Mr. Alison, in his work entitled *The Principles of Population, &c.*, are peculiarly appropriate:—

“As the division of land is thus the great step in the progress of improvement, so its distribution among the lower orders, in civilised society, is essential to maintain that elevation of mind which the separation of employments has a tendency to depress. It is too frequently the melancholy effect of the division of labour which takes place in the progress of opulence, to degrade the individual character among the poor; to reduce men to mere machines; and prevent the development of those powers and faculties which, in earlier times, are called forth by the difficulties and dangers with which men are then compelled to struggle. It is hence that the wise and the good have so often been led to deplore the degrading effect of national civilisation: that the vast fabric of society has been regarded as concealing only the weakness and debasement of the great body by whom it has been erected; and that the eye of the philanthropist turns from the view of national grandeur and private degradation, to scenes where a nobler spirit is nursed, amid the freedom of the desert or the solitude of the forest. To correct this great evil, Nature has provided various remedies, arising naturally from the situation of man in civilised society, and one of the most important of these is the distribution of landed property among the labouring poor. It is this which gives elevation to the individual character; which gives a feeling of independence to the industrious labourer, and permits the growth of those steady views and permanent affections which both strengthen and improve the human mind. It is this, in short, and this alone, joined to the religious and moral education of the great body of the people, which is adequate to counteract the degrading effect of national civilisation upon the poorer classes; which can permit the growth of the human mind to keep pace with the advancement of knowledge and the progress of general improvement; and enable the poor to retain, in periods of wealth and civilisation, the individual character and the station in the community which belonged to them when society existed in a more simple form.”

“To improve the habits and enlarge the ideas of comfort among the poor, the acquisition of property of any kind is of great importance; but the effects

The banks of the Seine differ from those of any river in Britain in exhibiting no large or full-grown trees. There are only two or three spots between Havre and Thomery where

of landed property seem to be beyond any other. There is something healthful to the human mind in the possession of a portion of the earth. Property of other kinds is easily squandered or dissipated, and never can give rise to those feelings of attachment which spring up in the minds even of the lowest of mankind with the acquisition of property in land. The incessant labour which it requires; the habits of solitude or of domestic society to which it gives rise; the permanence of the object itself; all tend to introduce habits of foresight and attention, and to check that propensity to present indulgence from which so much misery arises to the lower orders. And in so doing it promotes, more than any other species of property, the growth of those dispositions and habits which restrain the operation of the principle of population.

“The great difference between the effects of property in land and in money upon the human character, consists in the superior facility of dissipation which the latter possesses. The proprietor of a field cannot convert it into money, or render it the means of indulging individual gratification, without disposing of it to a purchaser, or burdening it with debt. But either of these is a great and decisive step, sometimes drawing after it a change of residence, an alteration of employment, and probably the sacrifice of habits and feelings of attachment. Men pause before they take so serious a step, or indulge in the habits likely to render it necessary. But the case is totally different with the possessor of a sum of money: it melts away insensibly with the indulgence of tastes for dissipation, and can be entirely spent without involving a change of home, a sacrifice of affection, or alteration of employment. Every person must have felt himself, or witnessed in others, the great difference between the facility with which an individual in the higher ranks draws on a bank or spends money in his possession, and disposes of his estate, or sells out of the funds; and hence the importance which the friends of every man of improvident habits attach to getting part of his professional earnings invested in land, or a house, or some other permanent object. The same principles operate with still greater force upon the poor, in whom habits of foresight are much slighter, and the desire of momentary gratification much stronger, than in their superiors; and hence the value of encouraging these habits, and counterbalancing these desires, by the strong feeling of attachment to home and landed property which is equally powerful in all mankind.”

On the latter paragraph we find the following judicious observations in the *Quarterly Journal of Agriculture*:—“The great national evils, therefore, resulting from a manufacturing state will be found to originate in the carelessness, recklessness, and profligacy which it is invariably apt to engender, and which naturally arises from an unnatural concourse of persons, and the contagious nature of vice among the poor. Manufacturing labourers thus often grow up without any settled habits or permanent objects, squandering their earnings in prosperity, and suffering in periods of adversity all the miseries of improvidence. The only cure for this malady of the mind is the creation of something to make it *worth while to resist present indulgence*; and none seems equal in efficacy to the prospect or the power of obtaining property in land. It is confessedly nearly impossible to prevent the bad effects resulting from the varied intercourse and crowded population of commercial cities; but much may be done and has been done, as in Yorkshire, Westmoreland, Flanders, and Switzerland, where manufactures are established in the country, by distributing small portions of land, and exciting the desire of purchasing them among the labouring poor, to a degree that may increase their activity and industry in their several employments, and render them at the same time more virtuous, orderly, and provident.” (*Quarterly Journal of Agriculture*, December, 1840.)

such trees can be seen. The reason is, large trees do not pay so well as small ones; because, to become large they require to stand many years, and the older they are the slower is their increase. In France, woods and plantations are made and managed entirely with a view to profit; and the most common source of this profit being fuel, the trees are cut down when their stems have acquired a diameter of 5 or 6 inches, or less. The timber of construction is for the most part grown on better soils than the high grounds which border the river. In England, wood is seldom or never grown for fuel, and the timber for construction is for the most part imported. Hence trees are grown and preserved, by the possessors of estates, more as objects of luxury than of profit. Hence, the wonderful difference between the banks of the Wye, and other well known rivers in England, and those of the Seine, and other rivers in France, which possess equal geological advantages. A principal source of the variety and beauty of the banks of the Seine depends on the Lombardy poplars, which are sprinkled along its banks, more or less, during the whole course of its length. These contrast with the round bare hills and tame coppices, and enrich their appearance at the same time. The worst feature on the banks of the Seine is the poor appearance of the corn crops, owing to the soil not being stirred to a sufficient depth. By this change alone, we should think, the produce might be trebled; independently of the additional produce that would be derived from an increased supply of manure, and greater attention to destroying weeds. It is singular, that though the French country labourer is fully aware of the advantages of deeply stirring the soil to vines, and keeping it clear of weeds, he seems to think it of no importance to corn crops.\*

Several interesting villas are passed between Rouen and Pecq, which we should have been glad to examine in detail. The principal are Rosny, which belonged to the Duchesse de Berri; and Château Lafitte, which before the revolution belonged to Charles X. when Monsieur, and is now on sale. There are a number of small villas, many of them pleasingly situated; some surrounded by walled gardens, trelliswork covered with vines, and verdant arcades, and one or two accompanied by terraces; but scarcely any one conveyed the idea to us of cultivated taste. The facilities for artistical creations are so great, however, from the variety of surface, the windings of the river, and the abundance of building material, that, at no distant time, the

\* By a passage in Gérardin's work, *De l'Instruction Publique en France*, quoted in the *Quarterly Review* for December, 1840, it appears that the produce of land under husbandry in England, compared with that similarly occupied in France, is as 722 to 200. The English Agricultural Society will soon show how the present produce of farm lands in England, great as it is beyond that of France, may be doubled, or even trebled.



banks of this river must teem with architectural and picturesque beauty.

The steam-boats, with their large paddle-wheels, create such immense waves, that they are undermining the banks wherever these are broken or perpendicular; and it is also said that they are destroying the fish, by disturbing the spawn which is deposited among the weeds, or in the sand in the shallow margins of those parts where the stream is broad and sluggish. These undoubted evils render it very desirable to introduce the mode of propulsion by a horizontal screw or by a horizontal pump, one or both of which substitutes for paddles will probably very shortly be attempted. From Pecq we went to Paris by the railroad.

*Paris.*—*July 9—29.* Much gratified with the order and high keeping of the gardens of the Palais Royal, and rather disappointed in those of the Tuileries; the latter having but few flowers, and those badly placed, with numerous blanks. The gardens at Monceaux suffering from drought, and the turf quite brown, partly from the dryness of the soil, but principally from the coarse kind of grasses of which it is composed, and from these grasses having been allowed to become so tall as to be fit for hay before they were mown, partly, also, from the exhaustion of the soil. The turf here might be rendered almost as green as that of England, by trenching the soil and mixing it thoroughly with loam, and by sowing it only with rye-grass and other suitable grasses, or with *Bròmus pratensis*, and keeping it clear of all broad-leaved plants. Even in the moist climate of England a smooth dark green lawn could not be maintained on such a soil as that at Monceaux, without either rendering it loamy by admixture, or invigorating the plants by frequent manuring. Enriching very dry soils with manure not only renders the foliage of a darker green, but, by rendering it of a firmer texture, enables it better to withstand drought. Any one may be convinced of this by observing the appearance of dry upland pastures in the driest seasons. One of the most striking proofs that we know of is the difference in the effect produced by extreme drought on the grass in the Hyde Park since it was top-dressed. Formerly the grass was burnt up almost every summer; at present the surface in the most sandy parts is rendered brown in the hottest weather, but the roots escape uninjured and resume their green colour with the first rains. We would therefore recommend all lawns on very dry sandy soils to be manured, or the soil to be mixed with loam, so as to render it retentive of moisture. There is an old hothouse in the walled garden here, which was erected by Mr. Blaikie between 1770 and 1780; it was sold during the first revolution, but bought in again after the restoration, and is still in tolerable repair. The panes of glass are about 1 ft. in width, with a curved lap; which lap is,

in all probability, a French invention, rendered advisable by the great width of the panes. *Spiræa Filipéndula rubra*, not yet, we believe, in British gardens, is now in flower for the first time. M. Schoene, the head gardener, is uncertain of the origin of this variety, which he procured some years ago from M. Cels. *Lýchnis fulgens*, *Matricària Mandiàna*, and a purple *Dólichos*, were also in great variety. The rose *Noisette Desprez* now makes a fine display. A fence of trelliswork, formed of young chestnut, with oak posts, and not painted, is found to last from twelve to fifteen years; the laths are placed at 9 in. apart, and tied to three horizontal rails by iron wire. It forms a very neat fence, and is much used in the gardens and pleasure-grounds about Paris, and even as a fence to the railroads. The chestnut used is that of young trees from 6 in. to 1 ft. in diameter, and it is never painted. M. Schoene tried the effect of paint, and found that it rendered the laths less durable, probably by enclosing the moisture. The bottoms of the seats in the pleasure-ground here are formed of two boards inclined to each other, and about 1 in. apart, as in *fig. 46.*, the object being to allow the immediate escape of the rain. A riding-house has recently been built here, 158 ft. French long, and 58 ft. wide, which is supposed to be the largest in Europe, except that of Moscow, of which a section is given in the *Encyclopædia of Cottage Architecture*.

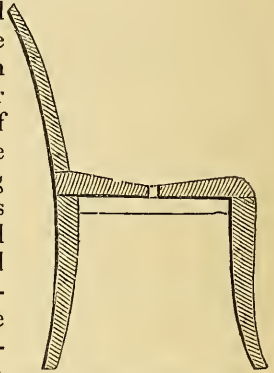

Fig. 46. Garden Chair in use at Monceaux.

*The Villa of Baron Rothschild*, at Surenne, is, perhaps, the best laid out and the best kept in the neighbourhood of Paris. Its extent may be 15 or 20 acres, on a surface originally flat; but it has been hollowed out in some places, and raised in others, under the direction of the architect, Beranger, so as to exhibit some variety. The house is small, and, in point of architecture, is without merit. The kitchen-garden is large, and contains a range of 600 ft. of hothouses, and about as many feet in length of frames and pits. Every luxury that a kitchen-garden can produce is raised in quantities, in season and out of season. An ornamental garden building contains a beautiful steam-engine, the machinery of which is seen at work through its large windows, pumping up the water to an elevated reservoir, whence not only the house and various fountains and cisterns are supplied, but also a system of pipes under all the lawns, with cocks at regular distances, to which leather pipes can be screwed on, and the surface watered with rapidity and ease. In some cases these pipes are laid along the upper edge of sloping banks, concealed by the grass; and, being pierced with holes, from these

the water, when turned on, issues as an inverted shower, rising to the height of several feet, and running down the slope, so as to water the whole of it. The contriver of this arrangement, and the proprietor who incurred the expense, deserve alike to be commended. Notwithstanding this extraordinary care, the lawn is far from having the smooth dark velvety green which characterises those of England, doubtless from the coarse kinds of grass of which it is composed, and from the very sandy soil and want of manure. A mixture of clay, or of clayey loam, to the depth of 6 in., sown with the common lawn mixture of grasses sold by the seedsmen, or with *Bròmus praténsis* alone, would have produced a very different surface.

The profusion of flowers distributed over the whole of this villa differs widely from any thing we have ever seen in England or elsewhere. Pots of geraniums are placed all along the boundary wall, next the public road, at regular distances; on the piers of the entrance gates; and in vases, at regular distances, on the parapet of both fronts of the house. The entrance lodge is ornamented with them, as is the ground all round the mansion, for several feet in width. But this is not all: the clumps and groups and belts throughout the grounds are bosomed up with scarlet geraniums and purple and white petunias; so that, in short, whichever way we turn we are met by masses of these flowers; by floricultural wealth in excess, with no more taste than a child would display in ornamenting a baby-house. What is it that prevents us from considering this profusion of flowers as in good taste? Is it merely that we are not accustomed to it in England, or is there any cause in the nature of things for this feeling in our mind? We think there is. Trees and lawns distributed after the manner of nature are meant to imitate nature: and though this imitation, to be artistical, ought to be, as much as possible, in a different material from what Nature herself uses in the given locality (that is, exotic trees, shrubs, and flowers should be used instead of indigenous ones); yet, it is not an imitation of nature fit for our climate, to associate plants which every one knows require to be grown under glass, with trees and shrubs which endure the open air; or to place plants in pots above the ground among plants which grow in the free soil, and which, by their shade and the nourishment drawn from the soil by their roots, would never permit the free growth of such plants. It would appear, then, that this mode of displaying flowers which require to be cultivated in the greenhouse, in such profusion in the margin of clumps, displeases, because it is not a true imitation of nature; it being conceded that the imitation of nature is the object of this particular style of landscape-gardening. Two other objections might be made; one is, that what is an ornament, and, like all ornaments, ought to be used sparingly, is here rendered common; and the other is, that the

beauty arising from plain unornamented parts of the grounds, as contrasted with highly enriched parts, is destroyed.

It may be asked if this mode of placing plants in pots round the roots of trees, and in the margins of masses, would be in better taste when applied to grounds laid out in the geometrical style than to those in the natural style. To this we answer no; because it is not the style alone which renders them objectionable, but the nature of the plants. It is the incongruous association of the natives of opposite climates which is so offensive; and it is also the placing of plants in a natural-looking situation which yet is not true to nature. By this we mean placing them at the roots of trees, under the shade of their branches; which, to a certain extent, appears a natural position, because we know that plants grow on the ground, and often near or under trees; but then we know, also, that they never could thrive so well under the shade of trees, as those which we see placed there in this and other French gardens. Plants placed in vases on the tops of houses, it may be said, are in a still more unnatural situation. Granted; but in placing them in that situation there is no intention to deceive. We know at once that they have been raised elsewhere; that they have been placed there by the gardener, and that the situation is such, that, to keep the plants alive and healthy, his constant attention is requisite.

One great object in laying out and managing a country seat in England is, to produce and maintain an appearance of quiet and seclusion; but the continual recurrence of forced flowers in pots, and the number of sanded paths seen at one time in most of the suburban villas of Paris, remind one of the town more than of the country. Even the raking of the gravel or the sand of the walks, so common in France and also in Scotland, has a bad effect with reference to seclusion; and, in our opinion, ought no more to be permitted than the paring of the grass verges, so common in England. In the farm and the kitchen-garden all may be bustle and activity, for these are requisite to the carrying on of cultivation: but in the flower-garden and the pleasure-ground all ought to be quiet and solitude; for by these means only can that contrast be produced to a town residence, which is calculated to insure the repose sought by a citizen in the country; or, at all events, which will be sought by him who has a just sense of the kind of enjoyments which ought to be found in every suburban villa.

After all, perhaps, we shall not easily persuade the majority of our readers that it is possible to have too many flowers in their gardens; and therefore we shall merely put our objections to the display so common in what are reckoned the best Paris gardens to the account of our particular taste. We could employ at Surenne legitimately all the flowers which we saw there;

that is, in a flower-garden by themselves, either in mixed beds or borders, or in symmetrical or picturesque figures with one kind in each figure; and by this means we would preserve an allusion to simple rural nature in some parts of the scenery, and create the richest artificial scenes in others.

The groups of trees and shrubs here are so very closely planted, that the plants are drawn up with naked stems, and are already becoming unsightly. The appearance in winter, when they are without foliage, of masses of naked rods must be any thing but agreeable. To make the most of these masses, they should have been planted much thinner, and consisted of a much greater number of kinds, both of trees and shrubs, and especially of evergreens.

*Bellevue, near Sévres*, the villa of M. Oudier, was laid out for some mistress of the royal family, before the first revolution; the gardener could not recollect the name. It contains two or three acres of ground, considerably varied, with a piece of water judiciously placed, rockwork, and some garden buildings in the style of the Petit Trianon. Among the trees are almost the only specimens of *Quercus pedunculata* that we saw in the neighbourhood of Paris. In the stove and greenhouse are some rare plants, recently brought from London and Belgium, and a tolerable collection of *Cacti*. In the open garden there are many dahlias, and a number of seedlings of *Salvia patens*, 4 ft. high, and beautifully in flower. The same fault is committed here as at Surenne, viz., the distribution of flowers all over the place. The lawn is watered by a portable forcing-pump, to which a leather hose, pierced with holes, and terminating in a copper rose, is attached. The gardener considers that he can do more work with the common watering-pot.

*Belleville, at Meudon*, the villa of Madame Gabrielle Oudier, is of greater extent than Bellevue, and it has a magnificent prospect, with Paris in the distance; but it has the same fault, of being rendered monotonous about the house by borders of flowers along the carriage road, as well as on the garden front.

*The Château de Meudon* is a small royal palace destined for the children of the crown, and occupied during the latter period of Napoleon's reign by his son. The view from the terrace over Paris, and to the wood of St. Cloud on the right, far surpasses any thing of the kind in the neighbourhood of Paris. There is scarcely any flower-garden, but there is an extensive natural wood of *Quercus sessiliflora*, pierced with narrow shady alleys in all directions, with some broad open avenues. Along one of these has been a hedge of spruce fir, which has been thinned out, and plants left at regular distances to take the form of trees; these have all shot out several leaders at the same height from the ground, and have now rather a singular appearance, which

may be compared to branched candlesticks. The orangery is an immense vaulted apartment under the terrace, in the manner of that at Versailles; and, like it, it preserves the orange trees through the winter without the aid of artificial heat. In front of the orangery is the forcing-ground, in which ananas are grown, as far as we were able to judge, as large as in England, more economically, and as rapidly. In summer they are grown on dung beds, in the open garden, in the rudest description of unpainted boarded frames, as at Versailles. The gardener, M. Gabriel, has raised an immense number of seedling ananas from seeds, chiefly of the Enville, ripened here; some with leaves perfectly smooth and dark green, others very prickly, some broad, others narrow, &c.; in short, if he chooses, he may pick out twenty or thirty very distinct varieties. An account of M. Gabriel's mode of cultivating the anana was given, in 1836, in the *Annales d'Horticulture de Paris*, vol. xix. p. 297., by M. Poiteau, which we have already noticed. There is a pit here, as at Versailles, entirely devoted to the culture of dwarf musas; and of these M. Gabriel possesses a plant the leaves of which are blotched, he says, permanently, with a rich velvety dark brown. This appearance is common in plants which are quite young, but it disappears when they grow 3 or 4 feet high; in M. Gabriel's plant, however, it remains.

(*To be continued.*)

---

ART. II. *On Sowing Seeds in Snow.* By M. LUCAS.

(From the *Garten Zeitung* for April 17. 1841.)

FOR five years past I have been very successful in sowing seeds in snow that are considered difficult to germinate; such as the following alpine plants: *Gentiàna*, *Ranunculus*, *Anemone*, &c., and in this manner I raised several hundred young gentianas in Messrs. Hague's establishment at Erfurt. In our gardens in the North of Germany, it is a well known practice to sow the *Aurícula* in snow, and this spring the idea struck me of making the same trial with exotic seeds, which are generally more difficult to germinate; I therefore sowed a few of the seeds of New Holland plants, principally of the Papilionaceous and Mimosa kinds, also *Erica*, *Rhodoracææ*, *Cacti*, *Cucurbitacææ*, &c. &c., all of the most distinct families. I filled the pots with earth the most suitable to each kind of plant; I then put a layer of snow, then the seed, and covered it with another layer of snow. I set them in a box covered with glass, and placed it in one of the houses at a temperature of from 12° to 15° Reaumur (59° to 60° Fahr.), in which the snow melted. I was not deceived in my expectations; some acacias, such as *A. subcærùlea* and *A. Cunninghàmi*, and several mammillarias, such as *M. uncinàta*,

germinated in the course of two days. These seeds not only germinated well, but in rapidity surpassed my expectations; and I even succeeded in raising *Crotalaria purpurea* in this manner, which I had never been able to do before by any other method.

When the snow had melted on the latter, I did not cover the seed with a little sandy earth as I had done with the others, but waited till the germ had fairly made its appearance, when I put the sand on; and, from the success of both, I consider the practice is established as generally useful. When newly fallen snow is not to be had, that which is frozen in ice-cellars, and easily preserved till the month of June, will do equally well.

Besides the very interesting process of the germination of the seeds by this method, a number of obstacles are avoided, which have frequently a bad effect on germination. Such as, for instance, a thick putrid substance, which exudes from many seeds, and particularly from those of the *Leguminosæ*; and which, when in the earth and totally excluded from the air, has a very injurious reaction on the unfolding of the germ, but when in the free open air it is found to be uninjurious.

Professor J. Liebig of Giessen sent me a few days ago his opinion of my practice in the following words: — “It appears to me that the loose formation of the snow, which allows of an uninterrupted admission of oxygen; the exclusion of those foreign agents which are always found in a soil that contains corrupted vegetable matter; and, finally, the volatile alkali of the snow — all these causes combined effect the remarkable appearance of germination in this process.” The reason why *Rhodoracææ* must be sown on the ground without any covering, if you wish the seeds to germinate at all, seems to me to be found in the free influence of the air, and also in the exclusion of the carbonic acid during the first period of vegetation.

M. Lucas, an apothecary in Arnstadt, who is also a physiologist and most intelligent friend of gardening, some weeks ago sent me his opinion of my method of sowing seeds in snow, and he thinks that germination by this process is founded on the following principles: —

1. When the seed is in the snow, the temperature cannot be far from the freezing point, as long as there is snow there; the melted snow, provided it is not warm, does not draw any matter from the seed which is necessary for its vitality, therefore it remains the same.
2. The melted snow only moistens the surface of the seed without submerging it, and easily penetrates the cells of the seeds by means of the capillary tubes, from which the air must escape. If the seed is too moist, the excess of fluidity does not produce a proportionate softness of the seed, as the air that is contained in the seed cannot so easily escape to give place to the moisture.
3. Snow water contains a great

deal of oxygen, which facilitates germination, and which can immediately penetrate the seed. 4. Snow being a loose covering and a porous body, does not prevent the admission of air to the seed, and is, therefore, a powerful agent in promoting germination.

I need hardly mention that as there is a powerful excitement of the vital principal of the seed, a temperature of at least 12° Reaumur (59° Fahr.), even for alpine plants, is absolutely necessary; because, if the seed is in a colder temperature, it will not germinate, but on the contrary will ferment, and the snow water will penetrate into the seed and swell it out to double the size.

[Further results will be given in a future Number.]

---

ART. III. *Continuation of the Experiments of the Effects of Charcoal on Vegetation, made in the Royal Botanic Garden of Munich.*

By M. EDWARD LUCAS, formerly in the Munich Botanic Garden, and now Botanic Gardener at Ratisbon.

(From the *Garten Zeitung* for 1841, p. 25.)

ENCOURAGED by the universal interest which the application of charcoal in the cultivation of plants has awakened, I venture to lay before the reader the result of continued observations and experiments. This subject excited much curiosity in the course of the year; mention was made of it in a great number of papers, and experiments set on foot in many gardens of which I was an eye-witness. Success did not always equal the expectations formed of it; a circumstance, however, which is no disparagement to the efficacy of charcoal; for, in every case, either the manner of applying it, or the quality of the charcoal itself, was the cause of failure. In consequence of this, charcoal lost its repute in many gardens, while in others, where at first no experiments succeeded, it is, by persevering in the treatment, now applied to most sorts of plants. By some I was not sufficiently understood, particularly in my remarks on the moisture necessary for the charcoal, and hence the complaint that every thing damped off. I confess that I have spoken too loosely on this head, and, perhaps, have said too much; as in many cases, and particularly when used in pots, as soon as the capillary fibres of the charcoal are full, a superfluity of water would be useless or even injurious to the plants; when mixed with the soil, however, it requires more frequent watering than would otherwise be necessary. The chief cause of failure arose from having the charcoal too finely pulverised; by which its chief properties, capillarity, capability of condensing gases, and porosity, were lost. I was also reproached with having brought forward so old a subject; to this I reply that to me and to most lovers of plants



it was certainly new: but I quote in proof of that assertion a passage from Schrank's *Natural History of Plants*, to which my attention has been called: "Senebier found that leaves in carbonated water, or when mixed with tincture of gall-nuts, vegetate longer and better than when in common water. He also found that leaves which, when exposed to the sun in water, had ceased to develop oxygen, did so again, as soon as carbonate was added to the water. In some parts of Sweden the barley-fields were manured with charcoal, and the crop was twenty times more abundant. Rafn found that the different sorts of corn grew best in the sorts of earth in which charcoal predominated." Leuch's *Vollstandiger Düngerlehre*, ii. 1832, p. 310. to 313. and p. 541. to 550., is said, according to the *Allgemeinen Anzeiger der Deutschen*, to contain observations on charcoal; but I have not been able to get a sight of this book.

During the last year many interesting cuttings of plants rooted in pure charcoal, some of them very difficult sorts to root, of which the following are examples: *Dodonæa humilis*, *Corræa alba*, *C. rufa*, *Magnolia purpurea*, *M. glauca*, *M. humilis*, *M. fuscata*, *Myrtus moschata*, *Eutaxia Baxteri*, *E. myrtifolia*, *Chorozema Manglesi*, *Prunus Laurocerasus*, *Polygonum complèxum*, *Halèsia tetraètera*, *Witsènia corymbosa*, *Laurus Benzoin*, *Polýgala cordifolia*, *Táxus macrophýlla*, *T. baccata*, *Pinus canadensis*, *Andrewsia glabra*; several species of *Melaleuca*, *Diósma*, *Phýlica*, *Grevillea*, *Chirònia*; *Azàlea índica*, &c., *Erica ignescens*, tendrils of *Vitis vinifera*, *Nèrium Oleánder*, &c. Also of hothouse plants, *Jacquínia arborea*, *J. mexicàna*, *J. armillàris*, *Ilex paraguayensis*, *I. acutangula*, *Malpighia Aquifolium*, *M. glabra*, *M. coccifera*, *M. fuscata*, *Ardisia japonica*, *A. colorata*, *Citrus buxifolia*, *C. Aurantium*, *C. Médica*, *Limònia trifoliata*, *Guaiacum sanitum*, *G. officinale*, *Franciscea Hoppeana*, *Bauhínia aculeata*, *Stiffia insignis*, *Illicium anisatum*, *I. floridanum*, *Schòtia speciosa*, *Comoclàdia integrifolia*, *Copaífera* sp. Mexico, *Plumièria lactea*, *P. angustifolia*, *Gmèlina sinuata*, *Chitònia mexicàna*, *Laurus nitida*, *Inga Sàman*, *Quárea trichilioides*, *Cúrcas drástica*, *Dombèya acerifolia*, *Schránkia aculeata*, *Büttnera catalpæfolia*, *Acácia tamariscina*, *Karwínskia glandulosa*, *Chamædorea Schiedeana*, *Báctris setosa*, *Caryòta sobolifera*, *Doryánthes excelsa*, and others.

These examples may suffice; as they yield a sufficient proof that plants of the most opposite families root in pure charcoal, and mostly much better and easier than in sand or earth; and there are many of the sorts above mentioned which heretofore could not be successfully propagated in the Botanic Garden at Munich.

The propagation of *Cácti* in charcoal, again, produced the most favourable results. Most of the leaves and parts of

leaves which rooted in charcoal produced eyes in the course of last summer, and in general not only one but several, from which shoots sprang, which are now grown into strong plants. As examples, I will only mention *Vinca rosea*, *Vernonia tournefortioides*, *Oxalis Mandioccana*, *O. Barrelièri*, *Thunbergia alata*, *Gonolobus mexicanus*, *Aristolochia brasiliensis*, *Euphorbia fastuosa*, *Eugenia australis*, *Ipomœa superba*, *Ardisia japonica*, *Fuchsia fulgens*, &c. A number of similar leaves that have rooted have not as yet made shoots; they are, however, quite fresh, and full of sap, and have an abundance of roots. In most instances a protuberance was formed before the shoot was formed, and in many the eyes were close to the surface of the cut. The folioles of the *Zamia integrifolia* made three fleshy roots nearly 1 ft. long, and we may confidently expect that eyes will eventually be formed on them, though somewhat later.

Charcoal was not so much used for sowing seeds, but in cases where it was applied it showed extraordinary power. Cucumbers and melons, for example, germinated in it one day earlier than those sown in earth and plunged together with them in warm beds, and were strong plants; while the plants from the latter seeds continued stationary, though the treatment was the same.

Experiments were also made with a view to the application of charcoal in transmitting living plants; and for this purpose some young chamædoreas, ferns, calceolarias, salvias, verbenas, and young cabbage and cucumber plants, some with moss round the ball of roots, others without any covering, were put in dry or very slightly moistened charcoal, firmly pressed down, and the closed box placed for four weeks in an airy shed, on which the sun shone for several hours. At the expiration of this period the palms and ferns were found in a very fresh state; the calceolarias and salvias had some yellow leaves, but had made young shoots; a species of *Petunia* even flowered on the box being opened; the verbenas only had suffered, but were still alive; the young cabbage and cucumber plants taken out of dung-beds had rotted, but without injuring any of the plants lying beside them. Cut flowers of many different sorts of plants kept perfectly fresh and well in fine dry charcoal, for from eight to fourteen days. Radishes, parsneps, onions, and the turnip-like roots of *Oxalis lasiandra* Zucc., attained a considerable size in a bed filled 1 ft. deep with pure charcoal; and also kohlrabi, which was planted in it.

An interesting circumstance took place with the bulbs of the Duc van Thol tulip, which had been forced. In the month of May two bulbs of this species were put in the above-mentioned bed, to see whether they would become sufficiently strong during the summer to produce perfect flowers again next

winter. In the beginning of November, when the bed was cleared out, both bulbs had produced large leaves 3 in. long, and showed evident proofs of flowering. They were put in pots in pure charcoal, and as early as the middle of November perfectly formed flowers appeared. There is no doubt, therefore, that for other early forcing bulbs this method would also be successful. In the same bed there was planted amongst others a fully grown scorzonera, which had been pulled up from a bed, and had lost part of its spindle-shaped root; it grew very well, and flowered.

Late in October, cuttings from very young shoots with flower-buds were made from some fine dahlias, nine tenths of which rooted in a short time. They were put in charcoal in large seed pans; at the bottom of the pans under the charcoal was one third leaf mould.

Some trees, such as *Prunus Pádus*, *Cytisus Labúrnum*, *Fráxinus excélsior*, *Ròsa centifòlia*, were, at the suggestion of Dr. Zuccarini, who has always encouraged me in my experiments, and taken the liveliest interest in them, taken up in their first growth, almost all their absorbing roots cut off, and planted in holes filled with charcoal. For some weeks they were quite fresh, then the ashes and bird-cherries began to languish, and the greater part of the leaves fell off; in the mean time the second growth began, but somewhat later, and not so strong; the *Cytisus* and the roses, on the contrary, continued to grow well.

I enclosed in a box, filled with half peat-mould and half charcoal, some plants of *Dáphne striàta* and *D. Cneórum*, which I had brought from the Alps, to prepare for sending them off afterwards. I succeeded in my object; these plants, which are apt to have their roots injured by the most careful taking up, and hence very seldom thrive with the usual method of cultivation and the mould used, had in a few weeks made new roots, and began again to grow. This treatment should always be applied to plants like these which are difficult to root. As a mixture, I have always used charcoal ashes successfully for all sorts of plants, and also seen it used in several other gardens; for example, for camellias, ericas, roses, pelargoniums, carnations, dahlias, palms, ferns, &c.; and I think that this use of it will become more general in districts where clay or chalk predominates, and where the mould used for growing plants is more compact than in sandy districts, and hence charcoal, as a means of producing porosity, must have a very favourable effect on the plants.

To prove if any difference existed with respect to the efficacy of the charcoal of different sorts of wood, the garden inspector, M. Seitz, had charcoal made from eight sorts of trees, viz. oaks,

limes, ashes, beeches, alders, willows, elms, and firs. These sorts of charcoal were kept separate, and placed in a warm bed in a hothouse, to these a space filled with bone ashes was added. In all the nine compartments leaves of the same plants were put: the eight sorts of charcoal had almost exactly the same effects; if there were any difference, I would give the preference to the fir ashes. It was very different with the animal ashes: in this little experiment they produced the most favourable results; many leaves rooted in them which had not succeeded in the charcoal, and some very soon produced shoots.

I cannot resist saying a few words here, in conclusion of my observations, on the bed formed in the new propagating-house of the Royal Botanic Garden at Munich, built last summer. The house is sunk 4 ft. in the ground, is of an oblong form, and faces the E. S. E. The surface of the bed within is half a foot lower than the level of the garden, and is heated by a simple walled flue, over which a copper pan the length of the bed is placed, from which constant vapour arises, and which communicates heat and moisture to the charcoal, with which the whole bed is covered to the depth of 5 in., through perforated boards lying over the pan. The temperature of the water is, on an average from 50° to 60° of Reaumur (145° to 167° Fahr.). This sort of heating by water or steam is, in my opinion, the best method for propagating plants; and it is to be hoped that M. Seitz, from whose plan the house was built, will follow up his intention of giving a full description of it. I plunged my propagating-box, without a bottom, into this charcoal, and put the better sort of cuttings, and those which are difficult to root, in it. The movable lights were generally taken off during the night, and also sometimes in the day, that the moisture and drops of water might run off and be dried up. I stuck herbaceous cuttings in the bed without further preparation, and almost all of them grew easily and quickly.

In compliance with the wishes of several of my friends and patrons, I intend publishing in a small pamphlet all that has hitherto been known on the efficacy of charcoal, and I have already been promised communications on the subject from many quarters.

---

ART. IV. *Dimensions and Details for erecting various Kinds of Plant Structures to be heated by Hot Water or Smoke Flues, or by both Modes combined.* By THOMAS TORBRON.

THE kinds of plant structures which I am about to describe have been found good in practice, both by my late father and myself; and they were also approved of by the late eminent horticulturist Mr. Knight, with whom I had the honour to live as

head gardener. I do not mean to say that hot water is not a better mode of heating than smoke flues, but merely that very excellent crops have been, and still may be, raised by the latter unfashionable mode of heating. I also think that, in many cases, smoke flues may be more convenient, less expensive, and more easily managed than the hot-water system. I consider upright glass, whether in the front or ends, altogether unnecessary in forcing-houses, and that sufficient ventilation may be given by moving the sashes of the roof; and these also allow of access to the plants from the outside of the house when the weather is suitable. The details I have given will, I hope, be understood by the practical gardener, as well as by the architect and builder.

*Cherry-house.* Length 30 ft., width 16 ft.; height at back 12 ft., in front 5 ft. The trees may be planted in free soil, or kept in pots; in the latter case, they should be kept two years in pots before being forced. If the trees are to be planted in the soil, the front and end walls should be built on arches. A flue should enter from a furnace from the back wall at one end, and be conducted first along the front, and afterwards round the back, with a chimney in the back wall over the furnace. The rise from the bars of the grate to the floor of the flue should be 18 in., and the flue should be 3 ft. from the walls all round. No front or end glass, but a roof of movable sashes and rafters; the sashes, in two lengths, to lap in the middle. The top lights to be 1 in. wider than the lower ones; and the lower ones to run up and down in a groove formed in the rafter under the top light, so that the top and bottom lights may run free of each other. The door, or doors, in the end, or ends.

*Peach-house.* Length 30 ft., width 12 ft.; height at back 9 ft., at front 2 ft. The front and end walls to be on arches. The flue to be within 3 ft. of the front wall, and to be returned close beside it, leaving a vacuity of  $2\frac{1}{2}$  in. between. A trellis to be fixed to the rafters 15 in. from the glass, and the trees to be planted between the front wall and the flue. The sashes as in the cherry-house. The doors at each end, or one at the furnace end. The rise from the furnace to the floor of the flue, and the situation of the chimney-top, as in the cherry-house.

*Vinery.* Length 30 ft., width 14 ft.; height at back 9 ft., at front 2 ft. The end and front walls to be on arches, and the whole to be heated by one fire. The furnace to have a door 1 ft. square, and the sides of the fuel-chamber to be of Welch lumps; and the rise to the floor of the flue to be 18 in. as before. The flue to run 2 ft. from the front wall, and to return within  $2\frac{1}{2}$  in. of the back wall. The flue to be 18 in. deep, with the covers and bottoms of 1-foot tiles. Doors at each end, or at

the fire end if but one door. Sashes and rafters as in the cherry-house. Trellis as in the peach-house.

*A Propagating-Pit for Tanners' Bark and a Flue.* Length 30 ft., width 16 ft.; height at back 9 ft., at front 2 ft. Flue in the front, and thence along the back, 3 ft. from the back wall, and  $2\frac{1}{2}$  in. from the front wall. Pit, between the flues, 10 ft. wide, and 3 ft. deep. Walk, 3 ft. wide, between the back flue and the back wall. Cavity between the flue and the front wall and the walls of the pit,  $2\frac{1}{2}$  in. A door in one end, or in the middle of the back wall, into a shed. For shading the plants, and for retaining heat at night in severe weather, a canvass might be arranged inside, so as to run from each end to the middle, immediately under the roof. Sashes and rafters as in the cherry-house.

*A Propagating-Pit, without Tan, to be heated by a Smoke Flue and Hot Water.* Length 40 ft., width 14 ft.; height at back 8 ft., in front 2 ft. The furnace to have a boiler over it. The smoke flue to run all round the pit, and the hot-water pipes to be laid in gutters under the pit; means being provided to fill the gutters with water, and to let it off into a drain at pleasure. The pit over the pipes to be 8 ft. wide, and 15 in. deep, and to be filled with sawdust, sand, ashes, or mould, into which to plunge the pots, &c. A door through the back wall into a potting-shed.

*A Pit for fruiting Pine-apples.* Length 30 ft., width 16 ft.; height at back 7 ft. higher than the front, at front  $2\frac{1}{2}$  ft. higher than the pit. The pit to be level, 10 ft. wide, and 3 ft. deep if for tan, but 4 ft. deep if for leaves. The flue to go from the furnace to the front, and all round the pit; to be covered with 1-foot tiles, with a cavity between it and the front wall and the walls of the pit of  $2\frac{1}{2}$  in. A path of 3 ft. wide between the back wall and the back flue; over which early grapes may be produced by properly preparing the soil under the path, and covering it with a trellis to prevent it from being trodden on and soddened. Vines, cucumbers, kidneybeans, strawberries, &c., may be grown on shelves over the path, and also over the flues. Sashes and rafters as in the cherry-house, and a boiler, if desired, as in the preceding pit.

*A Succession-Pit for Pine-apples* may be, in all respects, similar to the above; but 2 ft. narrower, and with the outer walls 18 in. lower.

*A Winter Cucumber-Pit.* Length 30 ft., width 8 ft.; height at back 7 ft., at front 4 ft. A flue to run first to the front, and return under the back wall, with cavities of  $2\frac{1}{2}$  in. The space between the flues to have gutters for the pipes of a boiler, with a power of filling and emptying the gutters at pleasure; so as to have a command of either dry or moist air, as either may be

wanted. The floor of the pit may be supported on arches, or it may be made of planks, or of slates or tiles resting on joists. The pit to be filled with mould, sand, or sawdust, according as it may be desired to grow the plants in pots or in the free soil. A trellis may be made to hook on the rafters, on which to train the plants. The upper surface of the pit to be 2 ft. from the glass.

*Turnham Green, May 9. 1841.*

ART. V. *Notice of a Draw-Hoe in Use in Leicestershire.* By M. SMART.

THIS hoe, which I have not seen described or figured in any of your works, differs from all other hoes that I know of, in having a movable blade, and in admitting of the use of blades of different sizes. It has also a crane neck, not unlike that of the Spanish hoe, or of Mr. Ogle's sickle-hoe, described and figured in p. 258. The Leicestershire hoe, which, I think, may be called the Shifting-blade Hoe, is shown in *fig. 47.*; in which *d* is the head, consisting of a socket for the blade, and a tubular socket or hose for the handle, without the blade; *b* one of the blades not inserted in the socket; *c* the socket with the kind of blade inserted which is used for general purposes, and more especially for hoeing between rows of wheat; and *a* a socket with the blade *b* inserted, which is used chiefly for thinning turnips.

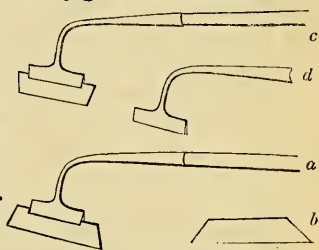

*Fig. 47. The Sliding Blade.*

*Fig. 48.* is a section across the socket, of the full size, showing the slit in which the blade is inserted.

The iron sockets, including the hose for the handle, should be about 14 in. long, with the crane neck bent about 3 in.; the socket should be 4 in. in length and 1 in. in depth, with a slit or cavity in the centre,  $\frac{1}{2}$  in. in depth and  $\frac{1}{8}$  in. in width, to admit the blade. The under part of the socket, containing the slit, should be made rather stronger than the upper part, as shown in the section, *fig. 48.* The neck, which joins the socket to the hose, should be about  $\frac{3}{8}$  in. in diameter, in order as little as possible to obstruct the view of the operator. The blades are removed from the socket by a rap or two on the back with a hammer or a stone; and they are refixed in it by placing the edge of the blade on a piece of wood, and giving a stroke on the back of the socket. *Fig. 48.*



The cost of the hose and socket, in Leicestershire, is about 1s. 6d.

The blades are formed by cutting into different lengths the blade of an old scythe, and unriveting the back-plate. Three or four hoe blades are obtained from one old scythe blade. The sockets vary from 4 in. to 6 in. in length, and the breadth, as above stated, is about 1 in. The most convenient-sized socket for wheat is 4 in., with blades of from 4 in. to 6 in.; and for turnips 6 in., with blades of 8 or 10 inches in length. For wheat-hoeing, the blades should be a little narrower at the edge than at the back, as in *fig. 47. c*; and for turnip-hoeing, and especially when the turnips are to be thinned, the blade should be widest at the edge, as in *fig. 47. a*.

The great fault of the common hoe is the thickness of its blade, by which it is with difficulty forced into the soil sufficiently deep to render the hoeing of much use; but with the shifting-blade hoe, in consequence of the thinness of the blade, and the material being steel, it requires no more force to stir the soil to the depth of 3 or 4 inches, than it does to stir it to the depth of 1 in. with the common hoe. In hoeing field turnips, you may send every man into the field in the morning with five or six blades for his hoe in his pocket, each of them as sharp as the blade of a scythe, and as thin; and these he can change in succession as they become dull; and the next morning he can sharpen the whole of them on the grinding-stone in a few minutes. Every one who has had much practice in turnip-hoeing knows how difficult it is to perform the work well when the corners of his hoe are worn off; but with the shifting-blade hoe, as soon as the corners get blunt, the blade can be thrown away and replaced by another.

*Bitteswell Hall, May 4. 1841.*

[We have sent one of these hoes to Messrs. Cottam and Hallen, Winsley Street, Oxford Street, who, if they should be asked for them, will manufacture them for sale.—*Cond.*]

---

ART. VI. *A new Method of forming Living Arbours.* By W. P.

I SEND, for insertion in your *Gardener's Magazine*, the following account of a method of forming a living arbour or fence. It has been spoken of, at various times, by Mr. D. Cooper, lecturer on botany, but has never been noticed in any of the gardening periodicals, that I am aware of.

To form an arbour, plant a weeping ash, the stem of which should be several feet high, in any convenient spot; at the distance of 4 or 5 feet from it, according to the size you wish to have the arbour, plant some of the common ash, at 6 or 8 inches' distance from each other, leaving a space of 3 ft. for the entrance; with every alternate plant slanting in an



opposite direction. By being brought together, they will now be found to form diamond-shaped openings; at the intersections a small piece of bark must be removed from each stem, and the stems bound together, and clayed in the same manner as for grafting: as the trees grow, they can be inarched to the pendulous branches of the weeping ash. This will be found to form a very strong living arbour; and by the same means a very strong and ornamental fence might be formed in a short time. I have no doubt other trees will answer the same purpose, but the ash is the only one I have seen tried.—*April* 16. 1841.

ART. VII. *Catalogue of the Cácti in the Collection of the Rev. Theodore Williams, at Hendon Vicarage, Middlesex.* By GEORGE LAWRENCE, Gardener there.

TRIBE PHYMATOCOTYLEDO'NEÆ.

GENUS I. ANHALO'NIUM.

Syn. ARIOCA'RPUS.

*Form* globular, top nearly flat or level. *Tubercles* formed of thick fleshy leaves (perhaps more like those of an aloe than a cactus); broad at the base, tapering to an acute, unarmed, and naked point; the upper side nearly flat, and the under side keeled. *Plant* glaucous, with white down between the tubercles. *Flowers* and *fruit* said to resemble those of *Mammillaria*.

- |  |  |  |
|--|--|--|
| 1 prismáticum. 2 in. high and 5 in. in diameter. — Syn. Ariocárpus retúsa. |  | 2 p. 2 majus. 2 in. high, and 5 in. in diameter. |
|--|--|--|

GENUS II. MAMMILLA'RIA.

*Surface* teated or tubercled. *Flowers* short, produced between the teats. *Berry* long and pulpy, concealed in an envelope of down till the seed is nearly matured, when it shoots forth, and presents itself to view.

Sect. I. SETA'CEÆ. — *Species having bristles and spines.*

Subject. 1. LEUCOCE'PHALÆ. — *White-headed.*

- |   |  |
|---|--|
| <p>1 geminispina. 4 in. high, and 6 in. in diameter; 3 heads. — Syn. M. acanthophlégma; M. leucocéphala; Cactus columnaris.</p> <p>2 elegans. 3 in. high, and 5 in. in diameter; 5 heads.</p> <p>3 polycántha. 4 in. high, and 4 in. in diameter.</p> <p>4 tetracántha. 5 in. high, and 3½ in. in diameter. — Syn. M. super-téxta.</p> <p>5 Parkinsonii. 3½ in. high, and 4 in. in diameter.</p> <p>6 lanífera. 4 in. high, and 2½ in. in diameter. — Syn. M. monacántha.</p> | <p>7 Perôte. 3 in. high, and 3½ in. in diameter. — Syn. M. diacántha nigra; M. Haageana.</p> <p>8 sphærótricha. 3 in. high, and 3½ in. in diameter. — Syn. M. candida.</p> <p>9 senilis Lodd. 3 in. high, and 3 in. in diameter.</p> <p>10 bicolor. 2½ in. high, and 2 in. in diameter. — Syn. M. geminispina; M. nivea var. minor.</p> <p>11 b. var. monströsa. 4 in. high, and 9 in. in diameter. — Syn. M. b. serpentina.</p> <p>12 nivea. 5 in. high, and 16 in. in diameter; 35 heads. — Syn. M. Toaldöæ.</p> <p>13 rösea. 2½ in. high, and 4 in. in diameter; 3 heads.</p> |
|---|--|

14 discolor. 7 in. high, and 10 in. in diameter; 50 heads. — Syn. *M. pulchella*; *M. canescens*; *Cactus depressa*; *C. pseudo-mammillaris*.

Subsect. 2. CYLINDRICOTHELÆ.—*Teats soft, long, and cylindrical, of humble growth (Cæspitôsæ).*

15 Wildiana. 3 in. high, and  $4\frac{1}{2}$  in. in diameter. — Syn. *M. glochidiata aurea*.

16 ancistrata. 2 in. high, and 2 in. in diameter.

17 glochidiata. 5 in. high, and  $8\frac{1}{2}$  in. in diameter. — Syn. *M. anciströides*; *M. cuneiformis*; and *M. crinita*.

18 g. var. rosea.  $2\frac{1}{2}$  in. high, and  $4\frac{1}{2}$  in. in diameter.

19 pusilla.  $4\frac{1}{2}$  in. high, and  $8\frac{1}{2}$  in. in diameter. — Syn. *M. stellaris*; *Cactus pusilla*; *C. stellata*; and *C. stellaris*.

20 vetula. 3 in. high, and 5 in. in diameter.

21 Schiedeana. 1 in. high, and 2 in. in diameter.

Subsect. 3. RUBICIPITES.—*Reddish tops.*

22 ignota. 4 in. high, and 5 in. in diameter.

23 ruficeps. 5 in. high, and 6 in. in diameter.

24 columnaroides. 12 in. high, and

3 in. in diameter. — Syn. *M. setosa*.

Subsect. 4. FLAVICIPITES.—*Yellowish tops.*

25 rutila.  $2\frac{1}{2}$  in. high, and  $2\frac{1}{2}$  in. in diameter. — Syn. *M. Eugenia*.

26 tentaculata. 5 in. high, and  $4\frac{1}{2}$  in. in diameter. — Syn. *M. pulchra*; *M. olivacea*.

27 hystericina. 4 in. high, and  $5\frac{1}{2}$  in. in diameter.

28 eriacantha. 10 in. high, and  $2\frac{1}{2}$  in. in diameter. — Syn. *M. cylindrica*.

29 rhodantha. 4 in. high, and  $3\frac{1}{2}$  in. in diameter. — Syn. *M. atrata-aurata hybrida*.

30 var. Audreæ.  $7\frac{1}{2}$  in. high, and 14 in. in diameter; 27 heads. — Syn. *M. inuncta*.

31 var. neglecta.  $3\frac{1}{2}$  in. high, and  $3\frac{1}{2}$  in. in diameter.

32 flavescens. 9 in. high, and 10 in. in diameter; 4 heads. — Syn. *M. straminea*; *Cactus flavescens*.

33 auriceps. 6 in. high, and 8 in. in diameter.

34 fuscata. 9 in. high, and  $6\frac{1}{2}$  in. in diameter.

35 chrysacantha.  $4\frac{1}{2}$  in. high, and  $5\frac{1}{2}$  in. in diameter.

36 aurata. 5 in. high, and 6 in. in diameter.

37 a. var. minor.  $4\frac{1}{2}$  in. high, and 5 in. in diameter.

## Sect. II. SPINEÆ.—*Species having spines, but no bristles.*

Subsect. 1. MULTISPINEÆ.—*Teats faintly angled; spines many.*

38 coronaria. 18 in. high, and 4 in. in diameter. — Syn. *Cactus coronata*; *C. cylindrica*.

39 hamata. 11 in. high, and 4 in. in diameter. — Syn. *Melocactus mammillariæformis*.

40 nivosa. 6 in. high, and  $3\frac{1}{2}$  in. in diameter. — Syn. *M. tortolensis*.

41 simplex. 5 in. high, and 4 in. in diameter. — Syn. *Cactus mammillaris*.

42 s. var. parvimamma.  $2\frac{1}{2}$  in. high, and  $3\frac{1}{2}$  in. in diameter. — Syn. *M. prolifera*; *Cactus prolifera*; *C. microthèle*.

Subsect. 2. TETRASPINEÆ.—*Spines few.*

43 polythèle. 7 in. high, and  $3\frac{1}{2}$  in. in diameter.

44 columnaris.  $7\frac{1}{2}$  in. high, and 3 in. in diameter.

45 quadrispina. 10 in. high, and  $4\frac{1}{2}$  in. in diameter.

46 obconella. 8 in. high, and  $4\frac{1}{2}$  in. in diameter. — Syn. *M. obscura*; *M. dolichocentra*.

Subsect. 3. POLYEDRÆ.—*Teats, most prismatic, all lactescent.*

§ i. *Teats large.*

47 polyèdra. 4 in. high, and 3 in. in diameter.

- 48 subpolyèdra. 8 in. high, and 4 in. in diameter. — Syn. M. polygona; M. xalapensis; M. anisacantha.
- 49 anisacantha. 8 in. high, and 4 in. in diameter.
- 50 Zuccariniàna. 3 in. high, and 4 in. in diameter. — Syn. M. macracantha.
- 51 Z. var. monstrosa. 3 in. high, and 5 in. long.

§ ii. *Teats smaller.*

- 52 càrnea. 3 in. high, and 3 in. in diameter.
- 53 Seitziana. 4 in. high, and  $4\frac{1}{2}$  in. in diameter.
- 54 uncinàta. 4 in. high, and  $4\frac{1}{2}$  in. in diameter.
- 55 u. var. biuncinàta. 3 in. high, and 3 in. in diameter.
- 56 glomeràta.  $2\frac{1}{2}$  in. high, and 7 in. in diameter.
- 57 hýstrix. 5 in. high, and 7 in. in diameter.
- 58 leucótricha. 3 in. high, and 6 in. in diameter.
- 59 leucocárpa. 8 in. high, and 15 in. in diameter; 2 heads.
- 60 xanthótricha. 2 in. high, and 4 in. in diameter.
- 61 macrothèle.  $4\frac{1}{2}$  in. high, and 5 in. in diameter. — Syn. M. conópsea.
- 62 deflexispina. 6 in. high, and 7 in. in diameter.
- 63 Karwínski. 4 in. high, and 9 in. in diameter; 6 heads.
- 64 centrispina.  $2\frac{1}{2}$  in. high, and  $3\frac{1}{2}$  in. in diameter.
- 65 æruginòsa. 4 in. high, and 5 in. in diameter.
- 66 diacantha. 4 in. high, and  $4\frac{1}{2}$  in. in diameter.
- 67 càput Medusæ. 5 in. high, and 13 in. in diameter; 9 heads. — Syn. M. sempervirens.

§ iii. *Teats more robust, and more globular.*

- 68 cirrhífera. 5 in. high, and 8 in. in diameter.
- 69 angulàris.  $4\frac{1}{2}$  in. high, and  $2\frac{1}{2}$  in. diameter. — Syn. M. compréssa.
- 70 subangulàris.  $4\frac{1}{2}$  in. high, and 7 in. in diameter. — Syn. M. cirrhífera spinis fúscis.
71. arietina. 5 in. high, and 7 in. in diameter.

- 72 magnimámma. 4 in. high, and 3 in. in diameter. — Syn. M. ceratóphora; M. Schiedeana.
- 73 éxsudans. 2 in. high, and 2 in. in diameter. — Syn. M. curvata.
- 74 gladiàta.  $3\frac{1}{2}$  in. high, and  $3\frac{1}{2}$  in. in diameter.

Subsect. 4. TE'NUÆ. — *Teats short; columns cæspitose, slender; yellow except the two last ones.*

- 75 echinàta. 6 in. high, and 7 in. in diameter. — Syn. M. densa.
- 76 elongàta. 10 in. high, and  $2\frac{1}{2}$  in. in diameter.
- 77 ténuis. 3 in. high, and 7 in. in diameter.
- 78 t. var. média. 3 in. high, and 12 in. in diameter. — Syn. M. stélla auràta.
- 79 t. var. subcròcea. 3 in. high, and 4 in. in diameter.
- 80 intertèxta. 3 in. high, and 2 in. in diameter.
- 81 sphacelàta. 7 in. high, and 12 in. in diameter.
- 82 grácilis.  $2\frac{1}{2}$  in. high, and  $2\frac{1}{2}$  in. in diameter.

Subsect. 5. LONGIMA'MMÆ. — *Teats long, soft, and cylindrical.*

- 83 longimámma.  $4\frac{1}{2}$  in. high, and 7 in. in diameter.
- 84 l. var. congésta. 3 in. high, and 4 in. in diameter.
- 85 uberifórmis. 2 in. high, and  $3\frac{1}{2}$  in. in diameter.
- 86 u. var. decipiens. 3 in. high, and  $3\frac{1}{2}$  in. in diameter. — Syn. M. inuncinàta.

Subsect. 6. AULACOTHE'LE. — *Teats large, lobed or channeled. Some, and, perhaps all, large-flowered, like those of the Echinocacti.*

§ i. *Columnar. Teats long, channeled.*

- 87 Lehmanni. 14 in. high, and 5 in. in diameter.
- 88 clàva. 10 in. high, and  $4\frac{1}{2}$  in. in diameter.
- 89 raphidacantha. 6 in. high, and  $2\frac{1}{2}$  in. in diameter. — Syn. M. clavata.
- 90 anastracantha. 7 in. high, and  $2\frac{1}{2}$  in. in diameter. — Syn. M. stipitata.

- 91 species nova; white, numerous, and straight spines. 5 in. high, and  $2\frac{1}{2}$  in. in diameter.  
 92 erecta. 9 in. high, and 2 in. in diam. — Syn. *M. evanescens*.  
 § ii. *Heads ovate or globular. Teats ovate, compressed, channeled.*  
 93 elephántidens. 3 in. high, and  $2\frac{1}{2}$  in. in diameter.  
 94 recurva. 3 in. high, and  $2\frac{1}{2}$  in. in diameter.  
 95 impexícoma.  $3\frac{1}{2}$  in. high, and

- 4 in. in diameter. — Syn. *M. radians*.  
 96 scepontocéntra. 3 in. high, and  $4\frac{1}{2}$  in. in diameter.  
 § iii. *Teats most robust, shorter, and broadly lobed.*  
 97 latimámma. 3 in. high, and 6 in. in diameter.  
 98 pycnacántha. 4 in. high, and 4 in. in diameter.  
 99 species nova. 3 in. high, and 5 in. in diameter.

## GENUS III. ECHINOCACTUS.

*Surface angled or furrowed. Flowers short and broad, produced at the fascicles of spines, generally at the umbilicus at the top of the plant. Capsule dry, generally concealed in an especial envelope of down, or else in the tomentum of the umbilicus. Fascicles of spines downy; down confined to the fascicles.*

Sect. I. SCOPÆÆ. — *Angles small and shallow. Spines slender and numerous. Fascicles small and prominent.*

- 1 scòpa. 14 in. high, and 4 in. in diameter. — Syn. *Cereus scòpa*; *Cactus scòpa*.  
 2 s. 2 cándida. 8 in. high, and 2 in. in diameter.  
 3 s. 3 cristàta. 3 in. high, and 3 in. long. — Syn. *E. scòpa monstrosa*.  
 4 pectinífera.  $4\frac{1}{2}$  in. high, and 3 in. in diameter. — Syn. *Echinocactus pectinata*; *Echinocactus pectinifera*.  
 5 p. var. rubrospina.  $2\frac{1}{2}$  in. high, and  $2\frac{1}{2}$  in. in diameter.  
 6 pùmila. 1 in. high, and 1 in. in diameter.  
 7 gracíllima. 3 in. high, and  $\frac{1}{2}$  in. in diameter.

Sect. II. GIBBOSÆ. — *Angles larger than those of the last section, formed of gibbous tubercles, confluent at their bases, having an acute tubercle at the bottom of each fascicle.*

- 8 exscúlpta.  $6\frac{1}{2}$  in. high, and  $2\frac{1}{2}$  in. in diameter. — Syn. *E. subgibbosa*; *E. acánthion-interrupta*; *E. crenata*; *Cereus montevidénsis*.  
 9. hybocéntra. 9 in. high, and 5 in. in diameter.  
 10 ignòta nòva. 8 in. high, and 5 in. in diameter.  
 11 gibbòsa. 3 in. high, 4 in. diam. — Syn. *Cereus gibbosus*.  
 12 g. var. nóbilis. 7 in. high, and  $4\frac{1}{2}$  in. in diameter.  
 13 centetèria.  $2\frac{1}{2}$  in. high, and  $3\frac{1}{2}$  in. in diameter.  
 14 ceratístes.  $2\frac{1}{2}$  in. high, and 3 in. in diameter.  
 15 pachycéntra.  $2\frac{1}{2}$  in. high, and  $3\frac{1}{2}$  in. in diameter.  
 16 Montivíllü.  $2\frac{1}{2}$  in. high, and 4 in. in diameter.  
 17 hypticacántha.  $2\frac{1}{2}$  in. high, and  $2\frac{1}{2}$  in. in diameter.  
 18 denudàta.  $2\frac{1}{2}$  in. high, and  $3\frac{1}{2}$  in. in diameter. — Syn. *Echinops denudatus*.

Sect. III. *Angles small, obtuse; having a teat, or prominence, between the fascicles.*

- Subsect. 1. MAMMULOSÆ. |  
 19 mammulòsa.  $4\frac{1}{2}$  in. high, and  $4\frac{1}{2}$  in. in diameter. — Syn. *E. hypocraterifórmis*.

20 m. var. cristàta. 2 in. high, 5 in. long, and  $2\frac{1}{2}$  in. in diameter.

21 submammulòsa. 2 in. high, and 4 in. in diameter.

Subsect. 2. OTTONI'DEÆ.—*Tubercles more obtuse.*

22 Ottònis. 6 in. high, and 5 in. in diameter. — Syn. Cèreus Ottònis.

23 O. 2 tortuòsa. 4 in. high, and 5 in. in diameter. — Syn. E. muricàta.

24 O. 3 tenuispìna.  $2\frac{1}{2}$  in. high, and  $3\frac{1}{2}$  in. in diameter.

25 concinna.  $1\frac{1}{2}$  in. high, and  $2\frac{1}{2}$  in. in diameter.

26 Línkii. 3 in. high, and  $3\frac{1}{2}$  in. in diameter. — Syn. Cèreus Línkii.

Sect. IV. ERINA'CEE.—*Angles acute. Spines short. The upper fascicles horizontal, and the lower ones inverted.*

27 corynòdes. 4 in. high, and 6 in. in diameter.—Syn. E. acutàngula; E. rosàcea var. Sellowiana.

28 acuàta. 3 in. high, and  $4\frac{1}{2}$  in. in diameter. — Syn. E. Courantii.

29 a. var. spínior.  $2\frac{1}{2}$  in. high, and 4 in. in diameter.

30 erinàceus. 5 in. high, and 7 in. in diameter.

31 Sellowiana. 4 in. high, and 6 in. in diameter.

32 sessilifòra. 3 in. high, and 6 in. in diameter.

33 s. var. tetracántha. 3 in. high, and 5 in. in diameter. — Syn. E. tetracántha.

Sect. V. *Angles few, and mostly robust.*

Subsect. 1. *Angles obtuse. Fascicles level.*

34 horizontalònia.  $5\frac{1}{2}$  in. high, and 6 in. in diameter. — Syn. E. équitans.

35 rhodacántha.—Syn. E. coccínea, Melocactus rhodacántha.

Subsect. 2. *Angles more acute. Fascicles teated.*

36 íngens. 6 in. high, and 5 in. in diameter. — Syn. Melocactus íngens.

#### GENUS IV. ECHINOFOSULOCA'CTUS.

*Surface angled or furrowed. Flowers and fruit like those of Echinocactus. Fascicles of spines downy: down extended above the fascicles in a straight or cruciform channel; sometimes confluent, or else in a circular patch, from which the flowers are produced invariably in the umbilicus.*

Sect. I. GLADIATO'RES.—*Angles numerous, dense, narrow, deep, and acute. Generally one or more of the spines in each fascicle flat, or sword-like, and erect.*

Subsect. 1. *Angles large.*

1 coptonigòna. 3 in. high, and 3 in. in diameter.

2 c. var. màjor.  $3\frac{1}{2}$  in. high, and  $5\frac{1}{2}$  in. in diameter.

Subsect. 2. *Angles dense, anfractuons.*

3 ensifórmis. 2 in. high, and 3 in. in diameter.

4 gladiàta. 4 in. high, and 4 in. in diameter.

5 crispàta. 3 in. high, and 4 in. in diameter.

6 obvallàta. 3 in. high, and 4 in. in diameter.

7 anfractuòsa. 3 in. high, and 4 in. in diameter.

8 phyllacántha.  $2\frac{1}{2}$  in. high, and 5 in. in diameter.

9 p. 2 macracántha. 3 in. high, and  $3\frac{1}{2}$  in. in diameter.

10 p. 3 micracántha. 3 in. high, and  $3\frac{1}{2}$  in. in diameter.

Sect. II. LATISPI'NEE.—*Globular. Spines broad and stout. Angles robust and acute.*

Subsect. 1. *Central spine hooked and broadest.*

- 11 cornífera. 1 ft. high, and 13 in. in diameter.  
 12 c. 2 elàtior.  $1\frac{1}{2}$  ft. high, and 1 ft. in diameter.  
 13 c. 3 rùbro-spina. 5 in. high, and 7 in. in diameter.  
 14 c. 4 angustispina. 10 in. high, and 10 in. in diameter.—Syn. E. stellàris.  
 15 spiràlis.  $4\frac{1}{2}$  in. high, and 6 in. in

diameter.—Syn. E. robùsta; Melocactus Bésleri affinis agglomerata.

Subsect. 2. *Spines more equal in size, narrower, much depressed.*

- 16 recúrva.  $5\frac{1}{2}$  in. high, and 10 in. in diameter.—Syn. E. gláuca; Cactus recúrva; C. nóbilis; C. multángula.  
 17 r. campylacantha.  $5\frac{1}{2}$  in. high, and 11 in. in diameter.

Sect. III. *Angles robust, acute. Spines round or angled.*

Subsect. 1. *Fascicles level.*

- 18 platýceras. 1 ft. high, and  $1\frac{3}{4}$  ft. in diameter.—Syn. ? E. macrodísca.  
 19 Vanderaèyi.  $1\frac{1}{4}$  ft. high, and 1 ft. 10 in. in diameter.  
 20 V. var. ignòta longispina. 1 ft. high, and  $1\frac{1}{4}$  ft. in diameter.  
 21 Karwinskiàna. 6 in. high, and 9 in. in diameter.  
 22 macracanthus.  $1\frac{1}{4}$  ft. high, and 2 ft. in diameter.  
 23 echídne. 9 in. high, and 6 in. in diameter.  
 24 helóphora. 11 in. high, and  $1\frac{1}{4}$  ft. in diameter.—Syn. E. irroràta.  
 25 h. var. longifossulàta. 1 ft. high, and  $1\frac{1}{2}$  ft. in diameter.  
 26 Mirbèlii. 9 in. high, and 8 in. in diameter.—Syn. E. holóptera.  
 27 Harrisü. 8 in. high, and 11 in. in diameter.

Subsect. 2. *Fascicles prominent, and teated.*

§ i. *Fascicles prominent*

- 28 oxýptera. 6 in. high, and 8 in. in diameter.  
 29 ignòta venòsa. 4 in. high, and 7 in. in diameter.  
 30 robùsta. 5 in. high, and 5 in. in diameter.—Syn. E. spectàbilis; E. subulifera.

§ ii. *Fascicles teated.*

- 31 Pfeiffèri.  $4\frac{1}{2}$  in. high, and  $5\frac{1}{2}$  in. in diameter.  
 32 holóptera. 4 in. high, and 5 in. in diameter.—Syn. E. spiràlis.  
 33 hexaedróphora. 3 in. high, and 4 in. in diameter.  
 34 turbiniifórmis. 3 in. high, and 4 in. in diameter.  
 35 species nova. 3 in. high, and 3 in. in diameter.

## GENUS V. ECHINONYCTA'NTHUS.

Syn. GLOBE CEREUS, or ECHINO'PSIS.

*Form globular, rarely columnar. Surface angled or furrowed. Flowers long and tube-like, produced at the top and also at the sides of the plants, generally nocturnal. Berry large and ovate, naked.*

Sect. I. MICRACA'NTHÆ.—*Spines short.*

- 1 Eyrièsü. 8 in. high, and 7 in. in diameter.—Syn. Cereus Eyrièsü.  
 2 E. var. gláuclus. 8 in. high, and 7 in. in diameter.  
 3 Schelhàsü. 6 in. high,  $6\frac{1}{2}$  in. diam.—Syn. Echinópsis Boutillièreü.  
 4 oxygónus.  $4\frac{1}{2}$  in. high, and 5 in. in diameter.—Syn. Echinópsis oxygónus.

- 5 turbinàtus. 10 in. high, and 5 in. in diameter.—Syn. Cereus geminatus; C. jasmíneus; Echinocactus turbinàta; E. sulcàta.  
 6 sulcàtus.  $1\frac{1}{2}$  ft. high, dividing into two main branches, with four heads, each 4 in. in diameter, making  $1\frac{1}{2}$  ft. in diameter in full.—Syn. Echinocactus decora.

Sect. II. MACRACA'NTHÆ. — *Spines long.*

- |  |  |
|--|--|
| <p>7 múltiplex. 11 in. high, and 7 in. diam. — Syn. <i>Cereus múltiplex.</i></p> <p>8 m. monstròsus. 2 in. high, and 2½ in. in diameter.</p> <p>9 tubiflorus. 8 in. high, and 6 in. in diameter. — Syn. <i>Cereus tubiflorus</i>; <i>Echinonyc. Zuccarini.</i></p> | <p>10 leucánthus. 7 in. high, and 7 in. in diameter. — Syn. <i>Cereus leucánthus</i>; <i>C. incurvispinus</i>; <i>Melocactus ambigua</i>; <i>M. elegans</i>; <i>E. campylacánthus.</i></p> <p>11 formòsus. 6 in. high, and 6½ in. in diameter. — Syn. <i>E. Gilliesii.</i></p> |
|--|--|

GENUS VI. MELOCA'CTUS.

*Form globular. Surface* angled or furrowed. *Flowers* produced on a bristly and downy cap at the top of the plant, smaller than those of any other section. *Berry* tubular and pulpy, concealed in the cap till the seed is matured; after which it presents itself to view. It is much like the berry of *Mammillaria*.

- |  |   |
|--|---|
| <p>1 commúnis. 1¼ ft. high, and 1 ft. in diameter. — Syn. <i>Cactus Melocactus</i>; <i>C. coronata.</i></p> <p>2 c. cónica. 1½ ft. high, and 1 ft. in diameter. — <i>M. c. 2 oblónga.</i></p> <p>3 c. 3 havannaénsis. 5 in. high, and 6½ in. in diameter.</p> <p>4 c. 4 víridis. 8 in. high, and 10½ in. diameter. — <i>Cactus Melocactus.</i></p> <p>5 c. 5 macrocéphala. 1¼ ft. high, and 1 ft. in diameter.</p> <p>6 pyramidális. 10 in. high, and 9 in. in diameter. — Syn. <i>Cactus pyramidális.</i></p> | <p>7 Hookèrii. 7 in. high, and 9 in. in diameter.</p> <p>8 Lemàrii. 6 in. high, and 6 in. in diameter.</p> <p>9 amœna. 4 in. high, and 6 in. in diameter. — Syn. <i>M. c. Jordénsii, M. rubens.</i></p> <p>10 meonacántha. 5 in. high, and 6 in. in diameter.</p> <p>11 violæcea. 7 in. high, and 9 in. in diameter.</p> <p>12 depréssa. 3 in. high, and 5 in. in diameter.</p> |
|--|---|

GENUS VII. PILOCE'REUS.

Syn. CA'CTUS, CE'REUS.

*Form* columnar, erect. *Surface* angled or furrowed, remarkable for long white hairs, besides the spines in the fascicles.

The singularly beautiful muff cacti in Mr. Lambert's museum have, for some time, been supposed to be the flowering parts of *Pilocereus senilis*; and the recent information which has been obtained on the subject leaves no doubt that this is the fact. We are told that this species, which attains a considerable height in its native country (specimens have been sent to England above 15 ft. long), when it attains its full growth, produces at or near the top a great quantity of brown woolly hair, which differs from that below, not only in its colour and quality, but in being extremely dense. The flowers are produced in zones in this dense hair or muff; but whether one or two zones of flowers are produced in each year we have not yet learned.

The second species, *P. columna Trajani*, is in the possession of my employer, and it has emitted an extra patch of hair on one side near the top, which has not yet extended round the column; thus it appears as though the column had burst, and protruded this dense tuft of hair from its inside. Whether this tuft will flower without extending round the column or not, remains to be proved.

- |  |  |
|--|--|
| <p>1 senilis. 3 ft. high, and 6 in. in diameter. — Syn. <i>Cereus senilis</i>; <i>C. brádypus.</i></p> <p>2 columna. 2 ft. high, and 4 in. in diameter. — Syn. <i>Cereus co-</i></p> | <p>lúmna Trajani; <i>Melocactus columna Trajani</i>; <i>Pilocereus cométus.</i></p> <p>3 monacánthus. 3½ in. high, and 2½ in. in diameter.</p> |
|--|--|

## TRIBE PHYLLARIOCOTYLEDO'NEÆ.

## GENUS I. CEREUS.

*Form* columnar, erect or creeping. *Surface* angled or furrowed, armed with spines. *Flowers* long and tube-like, produced in the fascicles of spines on the sides of the plant. *Berry* naked.

Sect. I. *Columns erect; rather thick. Angles large.*Subsect. 1. *Column robust.*

- 1 *Jamacáru*. 2¼ ft. high, and 4 in. in diameter. — Syn. *C. glaucus*.
- 2 *lætus*. 3 ft. high, and 4 in. in diameter. — Syn. *C. formosus*; *Cactus læta*.
- 3 sp. (black spines). 4 ft. high, and 3 in. in diameter.
- 4 *peruviánu*s. 2 ft. high, and 3½ in. diameter. — Syn. *C. hexagónus*; *Cactus peruviána*; *C. pentagóna*; *C. hexagóna*; *C. heptagóna*.
- 5 p. 2 *monstrósus*. 3½ ft. high, and 1½ ft. in diameter, branched. — Syn. *Cactus monstrósa*; *C. abnormis*.
- 6 sp. (brown spines). 2 ft. high, and 2¾ in. in diameter.
- 7 *geométricánu*s. 2 ft. high, and 3 in. diam. — Syn. *C. aquicaulénsis*.

- 8 *pruinósus*. 7 in. high, and 4 in. in diameter. — Syn. *C. róridus*; *Echinocactus pruinosá*.
- 9 *marginátus*. 1½ ft. high, and 3½ in. in diameter. — Syn. *C. incrustátus*; *C. cupulátus*; *C. Mirbèli*.
- 10 *robústus*. 3½ ft. high, and 4½ in. in diameter.

Subsect. 2. *Columns slight.*

- 11 *Forbèssi*. 9 in. high, and 2 in. in diameter.
- 12 sp. 4½ ft. high, and 2½ in. in diameter.
- 13 *tetragónus*. 2½ ft. high, and 2 in. in diameter, branched 1 ft. — Syn. *C. quadranguláris*; *Cactus tetragóna*; *C. pentagóna*.
- 14 *virens* (white spines and greenish). 2 ft. high, and 2 in. in diameter

Sect. II. *Columns tall, erect, and slender. Angles small, 6—9.*

- 15 *nágricans*. 2 ft. high, and 1½ in. in diameter.
- 16 *azúreus*. 2½ ft. high, and 1¾ in. in diameter.
- 17 *cæruléscens*. 2 ft. high, and 1¾ in. in diameter. — Syn. *C. Æthiops*, *C. Mendory*.
- 18 *repándus*. 4½ ft. high, and 2 in. in diameter.
- 19 *hýstrix*. 1¼ ft. high, 2½ in. diam.

- 20 *crenulátus*. 1 ft. high, and 1½ in. in diameter. — Syn. *Cactus Royèni*.
- 21 sp. (glaucous skin). 2 ft. high, and 2½ in. in diameter.
- 22 sp. 1¾ ft. high, and 3½ in. in diameter.
- 23 sp. (spines whitish green). 1 ft. high, and 2½ in. in diameter.

Sect. III. *Columns erect, short, and stout. Angles many, 7—22.*

- 24 *multanguláris*. 2 ft. high, and 3½ in. in diameter. — Syn. *Cactus multanguláris*.
- 25 m. 2 *nóbilis*. 1 ft. high, and 3½ in. in diameter.
- 26 m. 3 *spin. fúscis*. 9 in. high, and 2½ in. in diameter.
- 27 m. 4 *spin. álbis*. 9 in. high, and 2½ in. in diameter.
- 28 *chiloénsis*. 2 ft. high, and 4½ in. in diameter. — Syn. *C. coquimbánu*s; *C. Quintéro*; *Echinocactus pyramidális*; *E. élegans*.

- 29 *Dýckü*. 9 in. high, and 4 in. in diameter.
- 30 sp. n. (gibbous angles, and mealy skin).
- 31 sp. nov. (spines acute; angles green). 1 ft. high, and 4 in. in diameter.
- 32 sp. nov. (spines black and white).
- 33 *cándicans*. 1½ ft. high, and 7 in. diam. — Syn. *C. Montezúmæ*; *Echinocactus cándicans*.
- 34 *arachnoïdes*. 7 in. high, 4½ in. in diameter.



Sect. IV. *Columns branching. Fascicles seated on teats, which finally become confluent, and form obtuse gibbous angles.*

- |  |   |
|--|---|
| 35 Déppeï. 1 ft. high, and 3½ in. in diameter. — Syn. <i>C. cincrâscens.</i> | 36 pentâlophus. 6 in. high, and 6 in. in diameter, branched. — Syn. <i>C. leptacanthus.</i> |
|--|---|

## GENUS II. ASTROPHYTON.

Syn. *CÈREUS, ECHINOCACTUS.*

*Form globular. Surface obtusely angled or lobed; angles 5—7. Skin remarkable for being densely covered with small white spots. Spines none. Summits of the angles studded with round patches or fascicles of whitish down. Flowers like those of the Echinocâcti.*

- |   |   |
|---|---|
| 1 myriostigma. 5 in. high, and 7 in. in diam. — Syn. <i>Cèreus callicòche</i> ; <i>Echinocâctus callicòche.</i> | 2 m. 2 depréssa. 3 in. high, and 7 in. in diameter. |
|---|---|

In all there are, exclusively of seedlings and some very small plants: — Anhalonium, 2 sp. and var., and 3 specimens; Mammillaria, 98 sp. and var., and 428 spec.; Echinocactus, 33 sp. and var., and 99 spec.; Echinofossulocactus, 30 sp. and var., and 102 spec.; Echinonyctanthus, 12 sp. and var., and 63 spec.; Melocactus, 12 sp. and var., and 46 spec.; Pilocereus, 3 sp., and 19 spec.; Cereus, 36 sp. and var., and 105 spec.; Astrophyton, 2 sp. and var., and 4 spec.; making together 222 sp. and var., and 869 specimens. Besides these, there are about 4,000 small plants and seedlings, and numerous specimens of Opuntia, though, as they belong to very few species, they have not been inserted in the catalogue.

*Hendon Vicarage, April, 1841.*

## ART. VIII. *On the Cultivation of the Peach in Pots, in Pine-houses.*

By WILLIAM HUTCHISON, Gardener to E. J. Shirley, Esq. M. P.

As I consider I have been rather fortunate in growing peaches and nectarines in pots, in the pine-house here, probably it might not be uninteresting to some of the readers of the *Gardener's Magazine* to know how peaches can be produced in April; more especially as I do not remember ever having seen the subject treated on in that work.

Well, then, to begin at the beginning. Procure from the nursery good maiden plants, as soon after the leaves fall in autumn as possible; pot in sandy loam, enriched with one fourth well rotted sheep or cow dung. I have three sizes of pots in use; the smallest are 12 in. wide at top and 11 in. deep inside; the second size are 14 in. at top and 13 in. deep; the third size are 17 in. at top and 15 in. deep. The last is the largest size I use. After the plants are potted, plunge them in leaves, or any other litter, to save the roots and pots from the frost. If a pit or frame can be spared, it will be better to start the plants there the first year, than to put them into pine-house heat at once. Cut down the

plants to four or five eyes, and they will make as many shoots the first year. Place the plants in the pit or frame about the first of January, increasing the heat gradually, as the plants grow, to make the change to the pine-house as imperceptible as possible. All that will be required during the first year is, to keep the plants clean by daily syringing, and to water at the root as necessity requires, occasionally with liquid manure. When the trees have ripened their wood, let them be taken out and placed behind a north wall. In September they may be shifted into the second-sized pots, picking off a little mould from the top and sides of the ball of earth. This will complete the first year.

In January of the second year, place the plants in the pine-house at once. In pruning, cut in the shoots a little, according to their strength. If the plants have made good wood during the first year, they may be allowed to bear a few fruit during the second year; but I would not advise to be over-anxious about that, although in the second year I have gathered as fine Newington nectarines as I ever saw in a peach-house. Water and syringe, as formerly, till the wood is ripe; then take out the plants to their former situation behind the wall. By this time, if the trees have been managed properly, they will be fine stocky plants. Shift again in September; those that have grown strong into the largest-sized pots; others, that may not have grown very vigorous, may be placed in the same pots again, after reducing the ball sufficiently to admit of a supply of fresh mould. This will complete the second year.

Now, as the plants ought to be fit for work, means must be taken to make them pay for the trouble they have occasioned. To accomplish this, put in the plants on December 1. of the second year. Syringe every morning with tepid water; keep the floor of the house damp by watering, and raise steam frequently by watering the flues or hot-water pipes. This must be particularly attended to. You highly benefit the pines at the same time. During the last two seasons I have not been troubled with the aphid, or green fly, on any of my peach trees in the pine-house. I attribute this to nothing else but syringing the plants daily, and keeping the air of the house as moist as possible. With one of Scott's syringes, a dozen trees can be gone over in three minutes.

I keep the temperature as low during the night, in December, as I can, consistently with keeping the pines in health, about  $55^{\circ}$  Fahr.; from  $5^{\circ}$  to  $10^{\circ}$  higher during the day; with sun,  $10^{\circ}$  to  $15^{\circ}$  higher. Little or no air will be required during this month, unless the weather be very mild indeed. While the plants are in flower syringing must be dispensed with, and great caution used that too much fire heat be not applied. One night's neglect at this stage will blast your hopes for one year.  $60^{\circ}$

at night, during this time, will be enough; and  $75^{\circ}$ , with sun, will not be too much during the day. As the season advances, after the fruit are set, I keep about  $65^{\circ}$  at night; sometimes, on mild nights, a little higher, on cold nights somewhat lower; but during the day, with sun, I push them on now from  $80^{\circ}$  to  $85^{\circ}$  till the fruit are stoned, and begin to smell; they will then stand a strong heat,  $90^{\circ}$  to  $95^{\circ}$ ; and repeatedly I have had my house at  $100^{\circ}$  of Fahr.: but recollect that abundance of moisture must accompany this high temperature. Keep the passages and pipes watered often, and the trees will flourish under the glorious heat of the sun.

Under the above treatment my trees are improving, and during the last two years I have gathered peaches on April 20. At present, my trees are a complete picture: I have eight dozen of fruit on five of my earliest trees, swelled to an astonishing size for the mode of culture. Mr. Brown, the worthy and respected gardener of the Marquess of Hertford, at Ragley, called here on Monday last, the 19th, the day previous to my gathering fruit. On entering my pine-house, Mr. Brown said, "Well! that beats all the peach-forcing I ever saw." I must say, I was not a little proud of the good opinion of such an authority. And recollect, this is all done without any additional expense, save the getting of the plants and pots in the first instance, as they do not at all interfere with either the pines or grapes. I have a pit in the centre of the house filled with pines, and the rafters covered with grapes, both in robust health.

In shifting, part of the old ball must be taken away, sufficient to allow for an annual supply of fresh mould. The peach tree roots so fast in rich light mould, that it soon establishes itself.

In watering, I give it in small quantities, sufficient to keep the trees moderately moist, till after the fruit are stoned, when I give it very plentifully, keeping the roots quite wet till they begin to ripen. I then cover the surface of the pots with moss, to save watering, giving as little as possible till the fruit are all off.

I will now conclude by giving a few words of advice to any of those who may be inclined to try the forcing of the peach in pots, at an early season, in pine-houses. I know of very considerable failures having taken place in several establishments during this season, that, were they all known, might deter others from making the attempt. However, no enthusiast will ever be inclined to give up his case as hopeless from one or two failures. Now, I have known gardeners purchase trees from the nursery two or three years old, pot them, and put them into the pine-house at once, and they failed. That will happen again, too, if it be tried. The only plan is, to commence as I have recommended; and, at the end of two years, your plants will have a mass of

fibres that will be able to imbibe nourishment sufficient to keep the system in healthy action.

Should frosty weather set in about November, your trees must be protected from the effects of it, as the buds will be swelled by that time; and, should they be subjected to severe frost on putting them into the pine-house, numbers of the flower-buds will never expand at all: of course, the want of a little precaution in this case will subject you to the loss of your crop.

*Eatington Park, Shipston-on-Stour, April 22. 1841.*

ART. IX. *Botanical, Floricultural, and Arboricultural Notices of the Kinds of Plants newly introduced into British Gardens and Plantations, or which have been originated in them; together with additional Information respecting Plants (whether old or new) already in Cultivation: the whole intended to serve as a perpetual Supplement to the "Encyclopædia of Plants," the "Hortus Britannicus," the "Hortus Lignosus," and the "Arboretum et Fruticetum Britannicum."*

*Curtis's Botanical Magazine*; in monthly numbers, each containing seven plates; 3s. 6d. coloured, 3s. plain. Edited by Sir William Jackson Hooker, LL.D., &c., Professor of Botany in the University of Glasgow.

*Edwards's Botanical Register*; in monthly numbers, new series, each containing six plates; 3s. 6d. coloured, 3s. plain. Edited by Dr. Lindley, Professor of Botany in the University College, London.

*Maund's Botanic Garden, or Magazine of Hardy Flower Plants cultivated in Great Britain*; in monthly numbers, each containing four coloured figures in one page; large paper, 1s. 6d.; small, 1s. Edited by B. Maund, Esq., F.L.S.

*The Botanist*; in monthly numbers, each containing four plates, with two pages of letterpress; 8vo; large paper, 2s. 6d.; small paper, 1s. 6d. Conducted by B. Maund, Esq., F.L.S., assisted by the Rev. J. S. Henslow, M.A., F.L.S., &c., Professor of Botany in the University of Cambridge.

*Paxton's Magazine of Botany, and Register of Flowering Plants*; in monthly numbers; large 8vo; 2s. 6d. each.

*Ranunculaceæ.*

1605. AQUILE'GIA 14289 glanduîsa 1 discolor *Botanist*, No. 219.

*Malvaceæ.*

2004. MA'LVA 17823 frâgrans  
*Synonymes: Málva odorâta Botanist*, 218.

*Balsaminææ.*

698. IMPATIENS  
rôsea *Lindl.* rose-coloured  or 6 au Pk Himalayas 1839. S r.m Bot. reg. 1841, 27.

A pretty Himalayan plant, with pink flowers, which will keep a long time in water (see p. 61.). "The pods are oblong, and covered with white wool."  
(*Bot. Reg.*, May.)

*Cactæcæ.*

1473. EPIPHYLLUM 12593 truncatum var. violaceum *Pact. Mag. of Bot.* viii p. 79.

A very pretty variety, with a great abundance of flowers. (*Pact. Mag. of Bot.*)

*Rubiæcæ.*

635. POSOQUE'RIA

versicolor *Lindl.* changeable  $\text{♂} \square$  or ... au Pk W Cuba 1839. C p.1 *Bot. reg.* 1841, 26.

A very handsome stove shrub, the flowers of which are first white, but afterwards become pink, and finally crimson. It flowered with Messrs. Loddiges. (*Bot. Reg.*, May.)

*Cyrtandræcæ.*

3715. ÆSCHYNA'NTHUS

maculatus *Lindl.* spotted  $\text{£} \square$  or 3 au.n S India 1839. C p.r.w *Bot. reg.* 1841, 28.

Another species of this handsome genus, which is a stove plant "requiring a strong heat and damp atmosphere during the growing season." It strikes freely from cuttings, and flowers irregularly, according to its season of rest. (*Bot. Reg.*, May.)

*Cobæcæ.*

498. COBCE'A

stipularis *Lindl.* large-stipuled  $\text{£} \Delta$  or 20 my.o G 1839. S p.1 *Bot. reg.* 1841, 25.

This is a very handsome species, with greenish flowers. It resembles the old cobcæa in habit; and though a perennial, and indeed half-shrubby, it may be treated as an annual, and raised on a hotbed for planting out in May. (*Bot. Reg.*, May.)

*Convolvulæcæ.*

491. IPOMCE'A

tyrianthina *Lindl.* purple  $\text{♂} \square$  or 10 au.n Dk.P California [*mag. of bot.* viii. p. 73. 1838. C r.m *Pact.*]

This splendid species was mentioned by Dr. Lindley in *Botanical Miscellany* of the *Bot. Reg.* for 1838; but the specimen here figured was imported by Mr. Henchman, nurseryman at Edmonton, with some *Cacti*, in June 1840. The tuberous roots, which Mr. Henchman describes as resembling those of mangold wurzel, were potted immediately in rich mould, and grew with such rapidity that "by the end of August they were large plants, and full of bloom. The plants continued in flower till November, when they gradually died down. The flowers, which are very numerous, and produced in clusters on long foot-stalks, continue open two days, except in very hot weather; but by the second day their fine rich hue has disappeared, leaving the ground colour a reddish purple." (*Pact. Mag. of Bot.*, May.)

*Scrophulariæcæ.*

3463. LOPHOSPERMUM 28982 erubescens var. spectabile *Pact. Mag of Bot.* vol. viii. p. 75.

A variety raised by Mr. Ansell of the Cambden Nursery, with pink flowers, spotted with white. (*Pact. Mag. of Bot.*, May.)

*Begoniæcæ.*

2654. BEGONIA 31539 Drègii *Botanist*, No. 217.

*Orchidæcæ.*

3582. LÆ'LLIA

acuminata *Lindl.* acuminated  $\text{£} \square$  or '2 j P.W Mexico 1840. D p.r.w *Bot. reg.* 1841, [24.]

This species is said to be the flower which the natives call Flor de Jesus, from its great beauty. (*Bot. Reg.*, May.)

2542. CÆLO'GYNE

Cumingii *Lindl.* Mr. Cuming's  $\text{£} \square$  or 2 j W.Y Singapore 1840. D p.r.w *Bot. reg.* 1841, [29.]

A species nearly allied to *C. trinervis*, with white flowers, having a bright yellow blotch on the lip. It is a native of Singapore, and should be cultivated in a very warm moist stove, such as suits dendrobiums and plants of that kind. (*Bot. Reg.*, May.)

116. CRO'CUS

1012 minimus var. *Synonyme*: *C. annulatus Adamicus* W. *Herb.*, *Bot. Mag.* t. 3868.

1021. lagenæiflorus var. lacteus lutescens *Bot. Mag.* t. 3869.

## Amaryllidaceæ.

960. HÆMA'NTHUS [Mozambique 1839. D rub.s.l Bot. mag. 3870.  
tenuiflorus var. mozambicus *W. Herb.* slender-flowered, Mozambique variety ♂ ☒ or 1 ap Bri

This is a variety of a species of *Hæmanthus* from Delagoa Bay, which has not yet been introduced in a living state, though dried specimens have been sent to this country. It is very handsome; and it is grown in a pot filled "to a considerable height with old bricks and pots pounded, putting light loam above; and keeping the round bulb above ground, with its prolonged base under ground." (*Bot. Mag.*, May.)

979. ALSTRÆMERIA 28592 acutifolia. *Synonymæ*: *Bomarea acutifolia* *Mirb.*  
var. punctata *W. H. Bot. Mag.* 387.

*Bomarea* is a genus divided by Professor Mirbel of Paris from *Alstrœmeria*; and this is a variety of *A. acutifolia* from the Caraccas, which has the petals spotted inside. (*Bot. Mag.*, May.)

- SPREKELIA Heister. (In honour of *Dr. Sprekel*, a German botanist.)  
cybister *W. Herb.* tumbler ♂ ☒ cu ap W Bolivia 1839. D r.l Bot. mag. 3872.

A variety of this curious species was figured in the *Botanical Register* for 1840; and was noticed in the *Gard. Mag.*, vol. xvi. p. 346., where it was wrongly stated that *Sprekèlia* was one of Mr. Herbert's names. The genus was founded on the old *Jacoea* lily by Heister, a German botanist; and it contains the present species, *S. formosissima* (the *Jacoea* lily), *S. glauca*, and *S. cinnabarina*, all of which have flowered at Spofforth. (*Bot. Mag.*, May.)

- ELISE'NA *W. Herb.* (Derivation not given.) [3873.  
longipetala *Lindl.* long-petaled ♂ ☒ or 3 nr W Lima 1837. O s.l Bot. mag.

This genus was founded by Mr. Herbert on the *Pancrætium ringens* of the *Flora Peruviana*; but he considers the present plant to have completely the aspect of an *Ismène*. The plant "flowered at Spofforth in the greenhouse, at the end of March, in a 6-inch pot of white sand, with a very small admixture of loam, and produced eight leaves, with a scape above a yard high, and six flowers." (*Bot. Mag.*, May.)

## REVIEWS.

ART. I. *Catalogue of Works on Gardening, Agriculture, Botany, Rural Architecture, &c., lately published, with some Account of those considered the more interesting.*

*THE Field, the Garden, and the Woodland; or interesting Facts respecting Flowers and Plants in general. Designed for the Young.* By a Lady. 12mo, pp. 324, numerous woodcuts. London.

"The design of the following work is to present to the young reader several interesting facts, with which the botanist becomes acquainted in the pursuit of science. By stating them in a familiar form to the unlearned, the author hopes to awaken some interest in the study and observation of nature—a study alike elevating and consoling in its influences on the mind. It has been her object throughout the work, to direct the attention to the wisdom and goodness of God, as exhibited in the structure and arrangement of the vegetable kingdom; and to demonstrate the confirmation which is added by Nature to the doctrine declared by Revelation, of a superintending Providence."

The work is arranged in twelve letters, which embrace many hundreds of facts connected with flowers, and likely to be of popular interest. We do not know a better book for creating or strengthening a love of plants in a young person.

*Vegetable Physiology; being Part of a Popular Cyclopædia of Natural Science.* 8vo, pp. 295, numerous woodcuts. London, 1841.

This is the first of a series of volumes intended to be published on Natural Science, by a "Society for the Promotion of Popular Instruction." The Society "feel assured that it will be found sufficiently simple in its character, and clear in its explanations, to be regarded as an elementary treatise, adapted to those who have no previous knowledge of the subject; whilst its systematic arrangement, and the scientific nature of the principles laid down in it, render it an excellent introduction to more comprehensive works on the same subject. The general reader, who seeks no more than entertainment or recreation, will find it in this volume, in the copious illustrative facts and interesting collateral information with which it abounds; whilst to the agriculturist, the gardener, and the domestic economist, it supplies principles and practical applications of great importance." Contents. Introduction. Chap. i. Of the General Character of Living Beings, and the Distinction between Animals and Vegetables. Chap. ii. General View of the Vegetable Kingdom. Chap. iii. Of the Elementary Structure of Plants. Chap. iv. Of the Structure and Functions of the Roots. Chap. v. Of the Structure and Functions of the Stem. Chap. vi. Of the Food of Plants, and the Manner in which it is obtained. Chap. vii. On the Structure of Leaves. Chap. viii. Of the Functions of the Leaves. Chap. ix. General View of the Nutritive Powers in Plants. Chap. x. Of the Secretions of Plants. Chap. xi. Of the Production of Light, Heat, and Electricity by Plants—Motions of Plants. Chap. xii. Of the Reproduction of Plants. The work is creditably executed, and very cheap.

*A Treatise on the Cultivation of the Cucumber in Pots, so as to produce Cucumbers every Day in the Year, with less Trouble, more Certainty, and less Expense, than by any other System hitherto published; also in Pits, on Dung Beds, in the open Garden, and on Balconies and Walls; to which are added, Directions for growing Cucumbers for Seed, the Destruction of Insects, the Cure of Diseases, and a List of the most esteemed Varieties of Cucumber for Prize Culture.* By W. P. Ayres, Gardener to John Dobede, Esq., Isham Place, Cambridge-shire. 12mo, pp. 46. London, 1841.

This is the third treatise on the culture of the cucumber which we have had to record since the commencement of our present volume. We first noticed the work of Mr. Mills, p. 229; next that of Mr. Duncan, p. 274.; and recommended it as treating the subject in a different manner from Mr. Mills, and for the same reason we must now recommend the treatise of Mr. Ayres, for it is quite different from either. Mr. Ayres grows his winter cucumbers not in pits or frames, but in low houses with steep roofs; a much more agreeable mode for the amateur than dung beds, and not less suitable for the professional gardener, for Mr. Ayres's father practised it upwards of thirty years.

*A Selection from the Physiological and Horticultural Papers published in the "Transactions of the Royal and Horticultural Societies," by the late Thomas Andrew Knight, Esq., President of the Horticultural Society of London, &c. &c. To which is prefixed a Sketch of his Life.* Royal 8vo, pp. 379, plates and woodcuts. London, 1841.

Mr. Knight is unquestionably the father of the horticultural science of England, as Du Hamel may well be said to be of that of France. The proof of this is to be found, in both countries, in the gardening publications that existed previously to the *Physique des Arbres* which appeared in 1758, and Mr. Knight's papers which were published in the *Royal Society's Transactions* in the beginning of the present century. The best previous works on gardening in Europe were those of La Quintinie in France, and Miller in England; and these may be considered at best as only rationally empirical.

Mr. Knight's *Treatise on the Apple and Pear*, and his papers in Dr. Anderson's *Recreations*, and in the *Transactions of the Royal and Horticultural Societies*, have laid the foundation of a new mode of treating the art of vegetable culture; and, in connexion with the exertions of the Horticultural Society of London while he was president, have called forth all those numerous new kinds of fruits, vegetables, and flowers, with which our gardens are now enriched or adorned. The volume before us comprises all the more valuable papers written by Mr. Knight that have reference to horticulture; and, though the doctrines they contain have long been embodied in elementary works, their collection will be hailed with satisfaction by the vegetable physiologist, as well as by the scientific gardener.

The sketch of Mr. Knight's life occupies about 70 pages, and is instructive as showing that his success was neither owing to superior education nor favourable circumstances, but to his own energetic mind, and to his steady perseverance in the pursuit of such objects only as he considered likely to prove useful to society.

We shall conclude this brief notice with a short extract from the Introduction:—

“A taste for horticulture has for some years been so universally cultivated, that all classes are familiar with Mr. Knight's name as a writer, and the extracts from his papers which are found in many of the periodical publications on horticulture and arboriculture of the present day, have caused the readers of these works to be in some degree conversant with the particular subjects on which he has treated; and, though the value of the present work may be diminished by the task of editing it having unavoidably fallen to those who are ill-qualified to do justice to the undertaking, they are still cheered by the hope that their imperfect attempt may, nevertheless, by making both Mr. Knight's character and his writings better known, be the means of demonstrating more fully to the world the constant and never-tiring exertions of his mind in the pursuit of knowledge, and its application to purposes of practical utility, for the benefit of his fellow-creatures.” (p. vi.)

## MISCELLANEOUS INTELLIGENCE.

### ART. I. *General Notices.*

*CATERPILLARS on Vines.*—I have been very much troubled with a green caterpillar on the vines in one of my vineries for several seasons past, which is very difficult to find, as it chiefly feeds by night, and is so nearly of the colour of the vine leaves as scarcely to be distinguished from them. The best way that I could discover for destroying these insects was, to take a lighted candle into the vinery in the evening, and to examine the leaves which had been partly destroyed, when I have generally found the caterpillar feeding on them. In the daytime, I take the fumigating bellows with a very small quantity of tobacco in them, and blow the smoke well in among the vines, which causes the caterpillars to fall to the ground, where they may be easily killed. I kept a few of the caterpillars till they came to maturity; and, as I found by this means that they were the produce of a small brown moth, I was very careful to kill all the moths of this species that I saw in the vinery in autumn; in consequence of which, I am happy to say, I have seen none of the caterpillars this season.—*J. Catton. Rollison's Nursery, Tooting, December, 1840.*

*Steaming Mushroom-houses.*—My mushroom-house is a small back shed, 10 ft. by 11 ft., open to the roof. At one end is situated the heating and steam apparatus, which consists of a fireplace, with a flue 4 ft. in length, to conduct the smoke to an adjoining chimney; and over the fire is placed a 10-gallon boiler, open at the top, with a movable lid, and a tap to supply it with water



from a cistern in an adjoining shed. In the morning, the boiler being filled with water, I put a little fire under it, which soon causes it to boil. The house is soon filled with a mild sweet steam, which I generally keep up for two successive hours. In the evening a similar process is observed. A mild and uniform temperature is thus produced, generally ranging from 55° to 60° of Fahrenheit's thermometer, and an atmosphere saturated with moisture, in which the mushrooms thrive vigorously. I have thus produced weekly, from the 10th of November up to the present time (March), upon a surface of eight square yards, at an average, four large dishes of fine mushrooms, some of them measuring 23 in. in circumference, and thick and fleshy in proportion. I was led to adopt the use of steam from my beds requiring to be watered very often; and, in doing so, many of the small mushrooms were destroyed: but watering is now quite dispensed with; the steam coming in contact with the cold surface of the beds is rapidly condensed, and a copious supply of moisture is thus obtained. That a humid atmosphere is an essential point in the artificial culture of mushrooms, no one who has watched them in their natural haunts will deny. (*S. H. Crumpsall, near Manchester, in Gard. Chron., March 20. p. 181.*)

*Earthworms* have been found by Mr. Dunlop, gardener to George Fuller, Esq., Streatham, 14½ ft. below the surface, in the crevices of basaltic rock, on his father's farm, Well of Barnwell, in the parish of Craigie, near Kilmarnock. — *A. D. Streatham, April, 1841.*

*On boiling Potatoes.* — My comfort has been so much increased since I have had practised the preparing and boiling of potatoes according to the receipt given in the *Gardener's Mag.*, vol. vii. p. 369., that I cannot any longer refrain from informing you of the fact for the benefit of your readers, and in gratitude to your correspondent A. W., of Crosslee Cottage, near Glasgow, who furnished the receipt. The potatoes constitute a regular Pennsylvanian crop, but either from their inherent deficiency of good quality, or from ignorance in the mode of preparing and boiling them, a dry mealy tuber is rarely seen at dinner. Hence, when Lancashire or Irish potatoes are announced they are eagerly bought up, because they resist ignorance or carelessness on the part of the cook. Next to them, if not fully their equal, are the potatoes from the state of Maine (the most northern state in the Union), which originated in Mercer county, one of the extreme western counties of Pennsylvania, a few years since, from sowing the seeds of potato apples. The climate and soil of Maine agree admirably with these Mercers, and are so fine that they are in great demand. I find it, however, unnecessary to lay in a stock of them; for, since A. W's. receipt has been followed, the common produce of our market turns out white, dry, mealy, and well flavoured, and is purchased as wanted. — *J. M. Philadelphia, March 9. 1841.*

The receipt referred to is as follows:—Wash the earth off the potatoes, and scrape or pare the skins off; which last should be done as thin as possible, not only from motives of economy, but also because the outside of the potato is always the best. Then let them stand covered with, and soaking in, water an hour and a half or two hours. Wash them well out of this water; put a handful of salt with them in the pan they are to be boiled in, covering of course, with cold water, and boil quickly, the quicker the better.

*Aspergillus glaucus* is a species of fungus which grows on damp and putrefying fruit, bread, cheese, &c., and on plants while drying for the herbarium, if not regularly shifted. "This is the plant so well known," says Dr. Johnson, "by the name of the mould, and there is much interest in its history. At first, some white cobweb-like filaments spread over the substance infected, whence sprouts up a thick forest of other filaments, about one eighth of an inch in height, pellucid, tubular, and obscurely marked with one or two joints. Each filament is terminated with a globe, minute indeed to our enlarged vision, but large and heavy when compared with the slender stalk which supports it. This globe is entirely composed of pellucid grains, uncovered by

any membrane, yet closely compacted ; and if unravelled with a little care they will be found to be, occasionally at least, arranged in beaded lines of perfect uniformity. (*Flora of Berwick.*)

*Derangement of the Spinal Column.* — Though this is a subject that has nothing to do with gardening, we trust we shall be excused for noticing it on account of the connexion it has with a gardener, one of our correspondents, for whom we, in common, we believe, with all who know him, have a very great respect. We allude to Mr. J. D. Parks, a botanical collector sent to India and China in 1825 or thereabouts, by the Horticultural Society, and for the last fifteen years a nurseryman at Dartford in Kent. Mr. Parks, being out on a professional journey, had the misfortune to sleep in a damp bed, which brought on one disease after another, till, at last, his spine was so much injured that he could neither sit nor walk. For several years he was wheeled about in his nursery in a litter ; and we have frequently, when calling on him on our way to a villa the grounds of which we were laying out, been edified at witnessing his patience, resignation, and even cheerfulness. After trying numerous methods of cure, some prescribed by regular practitioners, and others by quacks, Mr. Parks at last cured himself. Of all this he has given the history in a shilling pamphlet, the perusal of which is as entertaining as a romance, and, to those families where there is a tendency to spinal complaints, it will be found as instructive as it is entertaining. The pamphlet, which is entitled, *The Cure of Spinal Complaints*, may be enclosed in a twopenny letter ; and we recommend such of our readers as wish to read an intensely interesting narrative, to write to Mr. Parks for it. — *Cond.*

---

## ART. II. Foreign Notices.

### NORTH AMERICA.

*NEW Cherry Tree from the far West.* — Messrs. Lewis and Clark, on their return from their western tour (1806), brought with them, among other trees, a new species of cherry, which was planted in Washington Square. The late C. S. Rafinesque ascertained that it was a new species, and sent an account of it to DeCandolle in the year 1830. He called it *Prunus (Cerasus) rotundifolia*, and thus describes it in his *Atlantic Journal*\* : — “Arborescent. Leaves rounded, base often subcordate, end obtusely acuminate, margin serrulate. Flowers fasciculate. Berries oblong, small, and black. A fine large tree, 20 ft. high in 20 (29) years’ growth. Bark very dark, nearly black. Branchlets slender, with a greyish brown bark. Buds small, rufous, with obtuse scales. Leaves like those of the apricot, but much smaller, about 1 in. long, not so smooth ; a little rough, but not pubescent. Blossoms in May ; and produces abundance of white flowers, with a fine smell of honey. The cherries are ripe in July ; small, one fourth of an inch long, elliptical, resembling small wild plums, but black, soft, and sweet when ripe. Good to eat, but if too many are eaten causing nausea, like all wild cherries. Stone oblong, acute, as in the plum, but without the three keels, as in the cherry.” — *J. M. Philadelphia, March 29. 1841.*

*Mammoth Cabbage.* — Some seeds of this French phenomenon were sent over last spring to the post-master of this city, Mr. Page, by an agent of the general post-office. Having been favoured with a few, I gave them to my neighbour, P. M’Kenzie. One only vegetated, and from its rapid growth, bid fair to become a sight ; but now, when one year old and carefully nursed all

---

\* *Atlantic Journal and Friend of Knowledge*, in eight numbers : containing 160 articles (original) and tracts on natural and historical sciences ; the description of 150 new plants, and 100 new animals and fossils ; many vocabularies of language, &c. &c. (Philad., 1833.)

the winter, it is only 2 ft. high, but with a stalk 1 in. in diameter. One reared by Mr. Page is the same height, and both are now in flower. Time only can show what they will come to.—*J. M. Philadelphia, March 29. 1841.*

*Sourmillier Potato.* — Some potatoes of a monstrous size, under this name, were sent from France last April as a new sort. I was presented with half a one, which P. M. M'Kenzie planted. The produce was much smaller than the parent tubers, and, when taken to the Horticultural Society, were pronounced to be Rohans. I had one boiled which was raised by a friend, and found it much inferior, as an esculent, to the common stock of the country. — *Idem.*

---



---

### ART. III. Domestic Notices.

#### ENGLAND.

*THE Exhibition at the Horticultural Society's Gardens*, held on May 15., was one of the best May exhibitions that have ever been witnessed. Five gold Knightian medals were given for plants, and one for fruits; eight gold Banksian medals for plants, and one for fruits; twenty-six large silver medals for plants, and two for fruits; sixteen silver Knightian medals for plants, and six for fruits; and eight silver Banksian medals for plants, and six for fruits. Among the plants were *Cytisus Weldenii* and *Ilex speciosa*: the first a beautiful hardy shrub, which may now be seen in flower at Mr. Groom's at Walworth; and the second an evergreen shrub, in the collection of Mr. Leaf of Streatham, and likely to prove hardy. — *Cond.*

*Kensington Gardens.* — Arrangements are in progress for supplying the grand basin in the centre of the gardens, and in the highest ground which they contain, with water from one of the water companies, and for measuring the quantity delivered with a meter; the most economical and fair mode for the public and the company. This basin is 20 or 30 feet above the level of the Serpentine River, into which the waste of the basin is to be delivered; and this river is a great many feet above the level of the canal in St. James's Park. Hence there might be a fountain formed at the upper, or north, end of the river, and one or more in the canal. As the river is in the natural style, the fountain in it might be in the form of a source, composed of huge masses of rock, from which the water might trickle down in streamlets, while in St. James's Park it might rise in a formal jet or jets. This is a mere rude outline of what might be done, at comparatively little expense; but were a greater expense to be indulged in, then, by having a steam-engine concealed among the trees in Kensington Gardens, a jet might be formed in the centre of the basin, of upwards of 100 ft. in height. Such a jet once existed in the pond in the Park of Barrackpore, Calcutta, of 120 ft. in height, forced up by an engine of 18-horse power. It was destroyed by Lord William Bentinck. We have more than once, in this Magazine, suggested the idea of having jets in the centre of some of the public squares; the engine being placed in some back street or mews. The first cost for one in Grosvenor Square, we are informed by an engineer, would be under 500*l.*, all expenses included; and the expense of coal and attendance, supposing the fountain to play six hours daily, would not exceed 3*l.* or 4*l.* a week; which, surely, might be raised by subscription among the occupants of the surrounding houses. We are informed also, by the same engineer, that the high service of some of the water companies would supply fountains in the form of jets as high as the houses, in several parts of London; but that the waste of water would render such fountains more expensive than those forced by steam-engines, in which the same water is used perpetually. — *Cond.*

*A public Park in the East of London* has been talked of for some time, and is at last likely to be carried into execution. We hope it will be of sufficient extent to be of real use to the surrounding population, and that it will be laid

out in such a style as to bring it into harmony with the other parks, become inviting to the wealthy classes as well as the general mass of the population, and thus assimilate, to a much greater extent than at present, the East end of the town with the West end. — *Cond.*

*The Margins of the great Lines of Railway*, that have been some years executed, are now becoming covered with grass, and much more agreeable to the eye than before; and, while lately gliding along the line to Birmingham, it occurred to us that additional interest might be given to the banks, at very little expense, by planting a collection of trees and shrubs on them. The plants might be a furlong apart; those on the sides of the deep cuttings may be shrubs; those on the sides of the embankments tall trees; and those where the ground on each side is nearly on a level with the road middle-sized trees, such as thorns, *Pyrus Sôrbus*, &c. Half-way between each tree or shrub there might be a tall-growing, striking, herbaceous plant, such as the hollyhock, Siberian parsnep, &c. We are not aware of any objection to this idea except the expense, which could not be very great, and if ever the ground came to be pastured by sheep, which we think must be its ultimate destination, the herbaceous plants might be given up. The trees and shrubs, when once planted, would require no expense whatever to keep them up, because the nurseryman who planted them might contract to keep them in order for three years, when they would be fully established. The herbaceous plants would require a small annual expense, but they might be omitted or given up when the ground was to be pastured. The fine effect, both of herbaceous plants and trees, may be seen on the bank on the right-hand side of the approach to the London terminus of the Great Western Railway. There the trees and plants are, very properly, numerous, so as to form a plantation; but along the railroads we propose the trees or shrubs to be a furlong apart, so as to form what may be called a varied and running foreground to the passing scenery. The directors of all the railways have paid most laudable attention to the architecture of the bridges, station houses, and all other buildings, and have succeeded in blending utility with architectural beauty in a highly gratifying degree. It would be only consistent, therefore, to confer some ornament on the naked banks, the formation of which was not less necessary to the existence of the railway than the building of the viaducts and bridges. To any person at all fond of observing trees and shrubs, the recurrence of a new species or variety about every minute would be a source of perpetual interest, and would not interfere with the distant scenery. The collection on one side of the road should have no connexion with the collection on the other side, in order that a person wishing to see the whole might confine himself entirely to looking to one side in going, and to the opposite side in returning. Many beautiful trees and shrubs might thus be brought into notice, that at present few people know any thing of. The banks of railroads in some parts of the country, when once they are completely separated from the road by the growth of the hedge, or by some other effective fence, might be let out as garden ground, or for orchards; but, in general, too little attention has been paid to preserving the old surface soil on the new surface, for these kinds of occupation. — *Cond.*

#### SCOTLAND.

*A General Cemetery* is in contemplation here on some ground which is beautifully varied on the surface, and abounds in rocks, and situations from which views of the sea are obtained; in short, on a part of Arthur's Seat. Rullian Green, on Pentland Hills, has also been talked of. — *W. D. Edinburgh, April, 1841.*

*White's Patent Heating Apparatus* has been applied to a vinery in Yester Gardens. Our readers will find a notice of Mr. White's apparatus, by Mr. M'Nab, in the present volume, p. 3. It is recommended for its great economy of fuel, and the comparatively little attendance it requires from the gardener. The following is an extract from a letter on the subject, addressed to Mr. White by the gardener at Yester, Mr. Dobson : —

“For the satisfaction of those interested in horticultural improvements, I have much pleasure in stating my opinion of the vinery erected here by you, for the most noble the Marquess of Tweedale.

“The vinery is of light construction, being of metal; the rafters of malleable iron,  $\frac{1}{2}$  in. broad and 3 in. deep; and the astragals of zinc. The house was finished during the autumn of 1840, and furnished with your heating apparatus. During the early part of the winter, I filled the vinery with a variety of greenhouse plants, both shrubby and herbaceous; and, notwithstanding the intense cold experienced early in January, I had no difficulty whatever in keeping the house at the temperature best calculated for the plants which it contained. Since then I have sufficiently tested, to my satisfaction, the power of your heating apparatus. In ordinary severe weather, while the thermometer in the open air, during the night, ranged between  $20^{\circ}$  and  $30^{\circ}$ , I found no difficulty in keeping the temperature to any point required between  $50^{\circ}$  and  $80^{\circ}$ , a range which I consider quite sufficient for any purpose of forcing. The stove was heated with coke; and, during a period while the thermometer ranged between  $60^{\circ}$  and  $76^{\circ}$ , the cost did not exceed 2s. 6d. per month. The fuel consumed during the time was 10 bushels.

“I have no hesitation in saying that your erection, taken as a whole, is a great improvement on the ordinary method practised in the construction of vineries, both as regards elegance and substantiality. Your method of heating is also well adapted for keeping up a regular and steady temperature. The system of regulating the heat is admirably arranged, which, with ventilation and supplying of fuel, may be intrusted to the care of any individual.

“Many noblemen and gentlemen have visited the house since its erection, and have expressed themselves highly pleased with its construction, also with the stove and hot-air flues. It is essential, however, that the fitting up of the stoves, flues, &c., be superintended with great care, in order to insure success.

“The house was recently planted with a variety of vines, and I am happy to inform you that they are now breaking well.”—*J. D. May*, 1841.

*Sir John Robison's Plant Case.* (Vol XVI. p. 117.)—The plant case of which I sent you a description has been successful in a surprising degree, the tropical plants have thriven and increased in size almost in an inconvenient degree, and have outstripped those of the same sorts which are in Mr. Ellis's case (as described in the *Gard. Mag.* vol. xv. p. 492.), although they are about three years the seniors. I ascribe this chiefly to the free space and more light which my case has afforded them. In the middle of February I put a number of Van Thol tulips in shells, with a little soil and moss, and suspended them over the plants in the case; they were over blown on the thirty-second day.—*J. R. Edinburgh, April 1841.*

---

#### ART. IV. *Retrospective Criticism.*

*MR. PENN's Mode of heating at Chatsworth.*—In the course of discussion on this subject in the *Gardener's Gazette* and the *Gardener's Chronicle*, it appeared that the extract of a letter by Mr. Paxton, given in our April No. p. 234., was not written by that gentleman, though the letter bore his signature. This circumstance seeming to us rather extraordinary, we wrote to Mr. Paxton on the subject, who immediately returned to us the following letter, with permission to publish it.

(Copy of a note sent to John Penn, Esq., by Thomas Bailey.)

“SIR,

*Chatsworth Gardens, April 6. 1841.*

“Mr. Paxton has again desired me to write for your accounts for heating the two Orchidæ pits here, which you will be kind enough to send at your earliest convenience.

“ Mr. P. has just shown me a letter in Glenny’s newspaper (sent him from the office), with his signature attached, which he complains of as conveying more than his opinion of it at any time would have warranted him to express. If the language published is precisely that made use of by me, which, to the best of my recollection, I doubt, Mr. Paxton had no more to do with it than desiring me to write you a civil note for him, expressing his satisfaction at the working of the apparatus at that time, and to request your accounts.

“ As a gentleman who has no desire to mislead, you will, perhaps, do Mr. Paxton the justice to publish this also.

“ I am, Sir, your humble servant,

“ JOHN PENN, Esq.

THOMAS BAILEY.”

*Plants adapted for a Conservative Wall.* — I turned with avidity to Mr. Scott’s list of plants adapted for a conservative wall, as published in your last Number; but it was only to find that such a list as your correspondent Mr. Kent (p. 45.) requires has still to be written. If a multiplicity of names be a merit, it is assuredly one that may be claimed for this list; but when I mention that a wall seven miles in length would be required to crowd the whole upon, you will agree, I think, that selection would be a far greater merit. The great number of species naturally precludes any approach to accuracy in classing them according to their comparative hardihood. We find *Illicium floridanum* (thoroughly hardy, and now in blossom here, after standing unprotected through the winter), *Berberis empetrifolia*, and *Mahonia Aquifolium* (both quite hardy), *Kérria japonica* fl. pl., *Cotoneáster microphýlla* and *rotundifolia*, *Erica austrális*, *Sálvia aúrea* (now in blossom here, out unprotected through the last winter), &c., all of which will stand in the open border or lawn without any protection, and *Bignônia capreolàta*, &c., which do not suffer in the least against an ordinary wall, classed with plants to which slight frost is certain destruction. I wish I had the Chatsworth wall at my command for a few years, you should have a list then deduced solely from experience. — T. B. Surrey, May 5. 1841.

*Mr. Niven’s Stove for various Purposes* (see p. 234. and 49.). — Mr. Niven informs us that he feels reluctant to answer the objections of Catius, unless that writer will give his real name. This we hope Catius will do, because discussion on the subject of Mr. Niven’s article cannot fail to be useful. — Cond.

*Shriveling of Grapes.* — The paragraph in p. 262. is the only one on this subject that I think points out the real cause, except my own article in Vol. XII., p. 494. I believe the cause to be too much moisture, with too little heat, as I never found early forced grapes subject to it. — J. D. Parks. Dartford Nursery, Dartford, May 12. 1841.

---

#### ART. V. Queries and Answers.

*MU’SA Cavendishii.* — My present employer is anxious to know what weight of fruit of this plant he may expect from a house 30 ft. long, 15 ft. wide, 12 ft. high at the back, and 6 ft. high at the front, heated both by flues and hot water. He also wishes to be informed whether the fruit is produced principally at one season, or whether, like that of the pine-apple, it may be had all the year. In a word, he wishes to be able to determine whether to devote this house to pine-apples or bananas. — J. S. Durham, May, 1841.

We shall be greatly obliged to any reader who will send us an early answer, founded on his own experience and observation, to the above query, which is from a young friend of ours who has just gone to his first situation as head gardener. — Cond.

---

THE  
GARDENER'S MAGAZINE,  
JULY, 1841.

---

ORIGINAL COMMUNICATIONS.

ART. I. *On the Philosophy of Manures.* By R. LYMBURN.

SINCE sending you the essay on Dr. Liebig's Physiology applied to Agriculture, I have seen the different publications of Professor Daubeny of Oxford and Professor Johnstone of Durham on the same subject. The philosophy of manures seems to have attracted the attention it so deservedly merits; and, when brought so prominently forward by men who, notwithstanding their profound knowledge of theory, are yet so cautious as to wish every thing confirmed by actual experiment, we may well anticipate great results. The experiments instituted by Professor Daubeny, and those pointed out by Professor Johnstone as proper to be conducted by agriculturists themselves, should greatly help to enable theory to point out the true action taking place in the conversion of the various substances exhibited as manures into the food of the plant. Having already occupied so much room in your valuable periodical (p. 97.), I will confine myself in the present essay to the notice of those subjects not previously brought forward by Dr. Liebig, or on which the above professors seem not perfectly agreed.

On the subject of Ammonia, Professor Daubeny remarks that, if we confine its source to that furnished by animals to plants, and if the plants which have furnished it to animals derived it from the atmosphere, either a superabundance must have originally existed in the atmosphere, and would, in that case, have been fatal to the then smaller quantity of plants, or there must be some other source of supplying the want of ammonia which increased population, and, consequently, cultivation, have rendered necessary. This source he considers volcanic; and that ammonia is formed by that combustion in the bowels of the earth, which is inferred from the observed escape of air from the earth, deprived of part of its oxygen. Water thus decomposed in the earth will yield both oxygen and hydrogen; the former of which uniting to carbon will form carbonic acid; and the latter, or hydrogen in its free nascent state (as hydrogen and nitrogen unite most freely when newly set free), unites to

the nitrogen of the air, and forms ammonia. Aided by the pressure of the superincumbent strata, ammonia is thus generated and emitted, like carbonic acid, from fissures in the earth. Sal ammoniac, or muriate of ammonia, is also largely formed, he says, among the lava currents recently ejected on the borders of lakes. Every particle of carbon and ammonia which now exists in plants and animals, he thinks, may have been originally evolved from the interior of our globe; and being emitted so largely in the neighbourhood of volcanoes will account, he thinks, for the fertility of the lava soils around Naples, as noticed by Dr. Liebig.\* Whilst we reason, he says, that animals are the source of nitrogen or ammonia to plants, while these very animals derive their nitrogen from plants, we are reasoning in a vicious circle; as it brings us to the conclusion that plants must originally have obtained their food exclusively from inorganic matter, there being no animals then. The sources of nitrogen and carbonic acid, at least of their increase to meet the wants of increasing civilisation, are, therefore, the emissions of inorganic matter from the earth. On this head, in the former essay, I stated that nitrogen being partially, to a small extent, soluble in water, the nitrogen of the air might, perhaps, form part of that assimilated in the plant; and Professor Johnstone, in his first lecture, seems to take the same view of the subject. Boussingault, the professor states, was of opinion that leguminous plants inhaled their nitrogen from the air.

Professor Daubeny says, 50 gallons of gas tar and 70 lb. of gypsum will produce 60 lb. of sulphate of ammonia, at the cost of only about 1*d.* per lb., not half the price of nitrate of soda; and where the carriage of gypsum is high, vitriol might be substituted. Where the coals contain much sulphur, there is likely to be sulphate, as well as carbonate, of ammonia in the gas tar. The professor, however, seems to be afraid that the mineral acids, especially if they are set free in quantities, and accumulated in the plant, will act deleteriously on the vegetable tissue; at all events, as stated in my former essay, the carbonate of ammonia, if washed into the soil in wet weather, or well diluted in water in dry weather (especially when the plants are in a growing state), will not suffer much loss; but, being dissolved in the water, which is capable of holding several times its own bulk in solution, will be absorbed by the roots, and thus furnish both carbon and ammonia. The spirits of tar, mixed with sand,

\* Mr. Allen, in his *Mineralogy*, p. 190., mentions that the hills of the Island of Lipari, of pumice rocks of volcanic origin, are very barren. Some further enquiries on this subject seem still needed: there appears much less alkali in the pumice that forms the hills, than in the obsidian which is found in the valleys.



and applied so successfully lately by Mr. M'Intosh at Dalkeith, owed their effect to the ammonia; which by the smell given off banished the insects, and, being absorbed by the roots, increased the vigour of the plants. I have lately seen powerful effects produced on onions, by sifting soot (a similar substance) on the beds in wet weather. In some instances, where the soot had not sufficed to go over the whole, the precise spot where the sifting stopped could be pointed out, by the plants that had got none being at least one third less in bulk.\* The carbonate of ammonia, therefore, though very volatile, if judiciously managed, should be a very safe and powerful manure; and it may be preserved in liquid manures by keeping them cool, or by adding loam or charcoal powder where this cannot be done, to absorb and retain the ammonia, and give it out again to the water of the soil. The method advised by Professor Johnstone, to dilute these manures in great quantities of water, and apply at different periods of the growth of the plant, points out the true theory of their action. Ammonia, Professor Daubeny says, in its caustic state, or unencumbered with acids, will kill plants, if confined in the air they are growing in, in the proportion of 1 part in 100; hence we see the poisonous nature of fresh unfermented urine, unless very much diluted: when allowed to ferment, the free ammonia is mostly converted into carbonate, and not so dangerous unless in excess. The ammonia of the sulphates and muriates should, when decomposed, as they must be in the plant, liberate the ammonia in a free state, till again neutralised by the carbonic acid of the plant, and be a further source of danger in employing those manures, viz. ammonia united to mineral acids in large quantities.

On the necessity of Nitrogen, as affecting the strength of plants and animals, I have seen families of Irish labourers in this town, who, I was informed, made their sole food to consist of potatoes and salt three times a day, and, though not so large and weighty as those fed on more stimulating food, were healthy active men. This food, I have been informed, is more exclusively prevalent in the inland districts of Ireland. The stimulating qualities of nitrogen seem, therefore, more conducive to bulk than better

\* All soots, however, are not beneficial. Having lately recommended soot as a dressing for onions to a friend in Stranraer, he said any time this had been done the whole crop had been destroyed. Peats are generally used there for fuel; and though the bog they are cut from is two miles from the sea, yet the ground slopes to it; and so great is the quantity of sea salt accumulated, that, where these peats are burned in cottages imperfectly finished, the soot collects on the joists, couples, rafters, and other wood-work of the house; and, in wet weather, so great is the quantity of salt contained in the soot, that it deliquesces with the moisture (not rain) of the air, and drops in salt (not acid) globules of water. This should convince those who have so frequently denied that salt is carried to any distance inland.

health. Manures, therefore, abounding in nitrogen exclusively, as nitrates of soda and potash, should increase the plant more by stimulating the tissue to expand in bulk, and abound more in soft mucilage than ripened starch; unless where there is a due proportion of carbon already in the soil, and where light and heat are found in sufficient quantity to elaborate the food of the plant.

A stimulating food will stimulate the action of the organs, and may cause greater results from the same quantity of food. The animal increases in bulk, not according to the quantity of food swallowed, but according to the activity of the digestive and absorbent system (the stomach and lacteals), and assimilating organs. In like manner, the greater activity of the absorbent and assimilating system of plants should produce more food, if the carbon and other constituents are present; but it should be on land otherwise rich, and mixed with other manures, that ammonia or nitrogen should produce its full effect. The action of the nitrates has been stated by some as being stimulating on the matters in the soil, or, rather, they seem to mean helping to reduce the vegetable matter in the soil, as lime; but this the nitrates cannot do till separated from the nitric acid, which neutralises them, perhaps by being decomposed in the plant, and again excreted. Their principal benefit, in the first place, is likely to arise from furnishing nitrogen, a stimulating food, to the plant; and they should, as before observed, be mixed with other manures, or applied to otherwise rich land, to produce their full and proper effect. Mr. Locke, gardener to Archibald Hamilton, Esq., of Roselle, informs me that these manures have been largely experimented on, in various ways, both on the farm and in the garden at Roselle this year; and to the public spirit of that gentleman we are likely to be indebted for some interesting information on this head.

Professor Daubeny seems still doubtful as to the truth of the theory of the Excretions of Plants by the Roots; and Professor Lindley lately, in the *Chronicle*, seems to participate in the same opinion. I mentioned in my former essay that I considered the decreasing quantity of alkali in wheat, as it ripened, a proof of the excretory theory being correct. If we allow that the roots imbibe every thing soluble in water, which is now generally conceded\*, we must admit that much will be taken up which cannot be assimilated in the plant; much, also, of what is capable of being assimilated, when in certain proportions, will often

\* Carbonic acid will pass through some membranes, as bladders, that will not allow hydrogen to pass; and spirits of wine and water are similarly situated. A discriminating power has been inferred in the tissue of the spongiole from this; but all substances fairly dissolved, not suspended only, in water, should pass along with the water.

be found in excess; and how is this excess and superfluous matter to be got rid of? Water, and even acids, may be evaporated; but how will lime and other alkalies and earths be expelled, unless by excretion? If silicate of potash, for instance, is in greater quantity in the water absorbed by plants than they require, it must be again returned. If we admit any of these are excreted, we must allow a general excretory power of all soluble substances when in excess; otherwise plethora would be produced, if the excess were deposited and not extricated.

On the views entertained by Professor Liebig, of the Carbon of Plants being exclusively got from the atmosphere by the leaves, and only the fixed ingredients by the roots, Professor Daubeny, at p. 65., seems to lean to the contrary opinion. Professor DeCandolle, in his *Vegetable Physiology*, lately translated and published in the *Gardener's Gazette*, says that leaves, and all the epidermis of plants, will, under certain circumstances, absorb nutriment, as will animals sometimes by the skin (life has sometimes been preserved for a time by immersion in soups); but he altogether repudiates the idea of plants drawing the principal part of their food from the air. Dr. Carpenter, in his excellent work lately published on Comparative Physiology, says that the lower orders of plants, as *Algæ*, &c., are like some of the lower orders of animals, altogether composed of an absorbent substance on the whole surface; but, in the higher orders of plants and animals, he considers the absorbent surface as confined to the newly formed spongioles of the roots, and the lacteal absorbent vessels of the animal. The principal part of the carbon of plants, however, he considers, is derived from the atmosphere, by the leaves inhaling it by the green parts or by the stomata, as in respiration. Carbonic oxide may be thus inhaled, as well as carbonic acid. The opinions of theorists appear very undecided on this subject. As I stated in my former essay, Dr. Liebig considers the young plant to get its carbon principally by the roots, but to lose this power as it advances in age; though without stating how the constantly renewed young spongioles, always in the growing season presenting a newly formed absorbing surface, possessing all the vital energy inherent in newly formed tissue, can ever lose the property of conveying all the constituents of the food of plants. On this subject I enlarged so much before, that I have not opportunity to say much now. I still hold by the opinion, that practice cannot be so far wrong in burying such quantities of carbon in the earth. Manure spread on the ground, though in great measure preserved by the carbon being washed into the soil by rain, has not produced the same effect as that buried to a moderate depth, not out of the action of the heat and air. From the great quantity of carbonic acid

formed in the earth by *eremacausis*, or the slow action of the oxygen of the air; from its being soluble in such large quantity in the water of the soil, aided by the absorbent powers of the particles of soil themselves; from its known specific gravity, inclining it to accumulate in greatest quantity at the surface of the ground; and from the action of every shower of rain in washing all the gaseous substances of the air, soluble in water, into the soil, carbonic acid should abound much more in the soil than the air. All gaseous and fluid substances have a tendency to mix together to a certain extent, from a weaker or stronger affinity that they have for one another, though this affinity may not always reach the amount of what is called chemical. At the head of this list stands the affinity between the oxygen and nitrogen of the air, which is still a matter of dispute, whether chemical or not. Oil has a very slight affinity for water, yet it may be mixed to a certain extent; but heat will again lessen this weak affinity, and the lighter oil will swim on the top. Agitation is sufficient to loosen some very weak affinities. Carbonic acid has a pretty strong affinity for atmospheric air, as it has been found on high mountains; but this weak affinity is liable to be disturbed both by heat and agitation. It rises also very slowly in the atmosphere. In Mr. Dalton's experiments, a phial of atmospheric air was inverted, with the mouth open, over an open phial of carbonic acid, the external air being excluded: at the end of one hour no trace of carbonic acid was found in the upper phial, and it was three hours before it could be said to be found to have arisen plentifully among the atmospheric air. When the experiment is reversed, and the air phial below, the carbonic acid goes to the bottom at once; and though hydrogen will go down through carbonic acid, it is only from its superior affinity. On all these accounts, and for the reasons stated in our former essay, on the superior growth of trees divested of their buds to those divested of their fibres, &c., I still adhere to my old-fashioned opinions, till I can see better reasons for changing.

Dr. Carpenter's opinions on the Causes of Reproduction or fruitfulness in animals and plants are different from those of Professor Liebig. The latter supposed it to be caused by accumulation of nutriment. Dr. Carpenter supposes two *antagonist* principles in living beings: one *nutritive*, causing the animal or plant to increase in bulk; the other *reproductive*, which begins to act only when the other has come to maturity; and that this maturity is sooner arrived at in starved plants and poorly fed people, who have generally more and healthier offspring than the rich. This opinion certainly agrees more with observation than that of Dr. Liebig; but the antagonist principles are only imaginary, and we see no reason why poverty

should be required to be brought forward as the cause of fruitfulness. Poor people, who are diseased or unsound in their general health, will have diseased offspring also ; it can only be the labourer, whom necessary exercise, plain, wholesome food, and freedom from excessive care, have furnished with a healthy and vigorous body, who can produce a healthy offspring. Plants also differ from animals, in every plant being a congeries or system of individuals, and not a single isolated being ; every joint, every bud can be converted into a separate existence ; and it seems to depend on the quality of food furnished, whether this bud shall remain on the plant, and produce an extension of the system, or be perfected into the form of a seed, the germ of a new system of individuals.

Experiments on the Germination of Seeds, quoted some time ago in this Magazine from the *Annals of Philosophy*, I think, as made by a Mr. Taylor, and lately brought forward by Dr. Horner in the *Chronicle*, show that the different rays of the spectrum have very different effects in furthering germination : the violet, or deoxidising, end of the spectrum having a powerful effect in furthering germination ; the red, or oxidising, end destroying it altogether. This is a further proof of the benefit of alkalis in germination. In my essay on that subject in the Magazine for 1838, and in the review of the *Theory of Horticulture* last year, I stated that the experiments of M. Maltuen, on seeds placed at the negative, or alkaline, pole of a battery furthering germination, and the reverse at the positive pole, had led him to try the germination of seeds in phials of alkalis and acids, which produced the same results as the violet and red rays above quoted. The violet, or deoxidising, ray, the negative, or alkaline, pole of a galvanic wire, and the exhibiting of alkalis themselves, are apparently different ways of arriving at the same result, but are all conducted on one principle. The presence of oxygen causes acidity, and the separation of it produces an alkaline state of the substance acted on ; the violet ray and the negative pole are therefore alkaline, the red ray and the positive pole acid. Either of the methods will, therefore, if in equal quantity, produce the same result. I formerly stated that I had used lime as a cheap alkali, and as its being further useful in withdrawing a portion of the carbon necessary to be withdrawn in reducing the starch, the food of the young plants, to a soluble state. I there mentioned the result of the application, which was sufficient to confirm me in the correctness of the principle. I have had no seed of the same description since to operate on ; in fact, it is difficult to say when it is in a fit state, how far the moisture necessary to preserve the excitability, or life, of the tissue in the young embryo may be withdrawn, before death, or the loss of excitability, ensues. After this, every stimulus ap-

plied will only hasten decomposition. What would have been a stimulus to the living power, in preparing food, and exciting it to act upon it, will, after death, only hasten its destruction. I have since tried it frequently on fresh seeds, and found it generally to have the effect of accelerating their growth. In the *Mark Lane Express* of April 5., a correspondent states that, having steeped his mangold wurzel seed in water last year, he dried some of it in lime powder, and found that this came up three or four days before the other, and kept the lead, increasing more in bulk all the year round. This is an accidental proof of the theory being correct, produced without any preconceived opinions.

There has been so much said lately on the different Modes of Heating, that the subject is well nigh exhausted. The subjoined remarks I do not recollect to have seen made yet. Having seen none of the houses fitted up in any of these new methods, the remarks are merely theoretical. The uneasy sensation felt in some stoves, I think, should arise more from the want of moisture, than the want of motion, in the air. In very dry sultry weather, out of doors; we experience something of the same sensation; but, no sooner does the moisture of approaching rain begin to be suffused in the atmosphere, than the uneasy sensation leaves us. The air, in a dry state, is a bad conductor of electricity; and we are in something of the condition of a person standing on a glass stool, and charged with electricity: when the air becomes moist, the superabundance of electricity is conducted away, moist air being a good conductor, and the uneasy sensation goes off. Stagnant air, no doubt, will be prejudicial: but to a certain extent there is motion in the air in all houses of the kind, from the tendency of heated air to ascend, and of the colder to descend. I think it would have been an improvement in Mr. Penn's method to have made the cold air descend at the back of the house, and the heated air to ascend at the front: a stratum of heated air would thus always have been interposed between the cold atmosphere and the plants, and danger of frost been much less. The mouths of the drains for carrying on the circulation of the air should have been level with the surface of the ground, or as nearly so as possible; because, whatever cold air passes the mouth of the drain will not rise again, unless there are some pipes or flues near the surface to heat it; and the air in the drains should be as much heated as possible to near the mouth, to keep up the rarefaction of the air inside the drain, and consequent pressure of that outside. There should be no water in the drains, as it will lessen the rarefaction; it would be better to have the water in troughs above the pipes. Where bark pits are in the house, pipes or drains should be run through the bed: the heat will

keep up a constant rarefaction and draught; and the mouth of all drains or pipes, for circulation of air, should be as wide-expanded as possible. The chambers in which the pipes are confined are improper, because the stratum of heated air confined prevents both the conduction and radiation of heat. In a brisk cold wind out of doors, Professor Leslie found the heat carried off by conduction, owing to the constantly recurring contact of cold air, nearly equal to that of radiation; but in an atmosphere of confined air, if perfectly confined, and of the same heat as the iron itself, there will be no conduction at all. Iron is a much better conductor than radiator of heat, and there must be great loss in thus stopping nearly all the conduction of heat. Professor Leslie's experiments also pointed out that the effects of radiation on the differential thermometer diminished in proportion as the air of the room was heated. As the radiation of the thermometer itself would be less as the room was heated, the difference would even be greater than that exhibited. By surrounding the pipes with a stratum of confined air, we thus diminish incalculably the effects of the pipes. Were the pipes left free, or even in close contact with the masonry, without a stratum of confined air intervening, the heat produced would be greatly augmented. All iron pipes in houses should be coated with lampblack. Professor Leslie found that, when the radiating power of lampblack was estimated at 100, that of polished iron was only 15; and though rough cast iron, and rusted, will be much more, it will not have half the radiating power of lampblack. The power of water to radiate heat is equal to lampblack; and, on this account, as also on account of its simplicity, and the abundant source of moisture it supplies, I think the open-gutter system of Corbett will excel all others, for plant-structures at least. For fruiting-houses, the covers to the gutters should be made to fit as closely to the water as possible, when it is necessary to have dry air; as, if the water does not touch the conveying-tube in all quarters, the confined air generated in the empty space inside will always cause a loss of heat, in proportion to its surface. Of what use is it to carry the heated water past the nonconducting stratum of air, to be again deposited in the boiler? As the heated smoke and air around boilers, when allowed to escape from a chimney head, must cause a great loss of heat, I think the plan of W. H., lately stated in the Magazine, to combine a smoke-flue and pipes of heated water in the same house, should be productive of a good deal of economy.

*Kilmarnock, May 21. 1841.*

ART. II. *Notice of a Visit to Whitfield.* By J. B. W.

WHITFIELD, the seat of E. B. Clive, Esq., M. P., is about seven miles south-west of Hereford, on the skirt of the rich valley through which the beautiful river Wye flows. Although standing on elevated ground, the views from the house towards the east and west are limited by intervening hills, but in a northern direction the fine valley of the Wye is partially seen; towards the south, also, a pretty peep is obtained along the park, which on one side is bounded by a beautiful oak wood that covers a long ridge, and has an exceedingly good effect when viewed from any part of the grounds. The house is of brick, small, but very neat, and apparently kept in the best order. There are rather extensive grounds, through which the approach road *descends* to the house, a defect which in this case could not be remedied without altering the whole arrangement. Another fault in these grounds is the tasteless disposition of the trees and shrubs, which have evidently been stuck about without any consideration of their future effect. At the entrance to the grounds, the road passes through a grove of lanky forest trees, of the commonest kinds; which, on the one side of the road, serve no purpose except a partial concealment of the house and lawn, and are in themselves extremely unsightly. On the south front, a portion is separated from the lawn by an iron fence: this part contains a few beds for flowers, and some ornamental shrubs; and being several feet higher than the park, it forms a sort of terrace on that side. Unfortunately, however, a farm road passes close beneath the boundary, in full view of the windows of the living-rooms. A pond on the north front, partially hidden by trees and shrubs, has probably a pretty effect from the upper windows.

The kitchen-garden is a short distance from the house; it is situated in a sheltered spot, and has the advantage of sloping gently to the south; but the soil is a very strong clay, and consequently not well adapted for a garden. On entering from the pleasure-ground, through the north wall of the kitchen-garden, there are three plant-houses; the central one an upright-fronted greenhouse in the old style, and the two wings neat and well contrived structures, lately built under the direction of Mr. Wood, the gardener. In one of these there is a stage, in the other a bark-bed for forcing flowers. In front of these houses an uncommonly large maiden-hair tree is growing, which I judged to be upwards of 20 ft. high, and nearly 4 ft. in circumference at the largest part of the trunk. A broad walk goes down the middle of the garden, with a flower border on each side, backed by an iron espalier rail, much of the same plan as that figured and described by Mr. Booth in this Magazine.



This walk leads to a slip in which are several vineries and a peach-house. In the vineries the successional system of training is practised, and I understand they grow superior grapes. The melon-ground, and the space for common fruits, are on the east side of the kitchen-garden, where, also, it is intended to build a brick wall for the cultivation of the Flemish pears. Some of the trellising described and recommended by me in this Magazine has lately been set up, but with iron cross pieces instead of wood. Both Mr. Wood and Mr. Smith of Garnstone disapprove of these trellises; alleging that, as the fruit always hangs in the shade beneath the trellis, it does not acquire its proper flavour.

Jan. 20. 1840.

---

ART. III. *Burning of Soils, as a Means of improving them.*

BY JOHN FISH.

SOME soils are greatly improved by burning. In the North of Scotland this has become quite a trade. A three-edged spade is used, with a handle 9 ft. in length, and a cross head-piece 3 ft. in breadth. This is used for pushing forward, principally by the thighs. The turf is turned over 1 ft. in width, to the depth of 2 or 3 inches. When the turfs are somewhat dried, they are piled up in heaps, and burnt upon the ground. The richness imparted will depend upon the quality and quantity of the ashes. They should not be burnt too much, as it destroys their goodness. Those which calcine freely are considered best. Burning in small heaps is preferable to large ones. As soon as the ashes are cold, they should be spread equally over the ground (with the exception of the places where the heaps stand), and ploughed in immediately. Frequent ploughing and harrowing should be given, until the necessary depth and texture are obtained for the intended crop. What escapes the harrow should be well broken with wooden mallets.

As soon as the crop is cleared, the ground should be ploughed again, and exposed to the atmosphere. Lands improved by these means generally prove productive for a number of years. The soils most benefited are strong clays, and those containing an excess of inert vegetable matter. The carbonaceous matter contained in the ashes is more beneficial to the crop than the vegetable fibre from which it was produced, as the injurious acid is destroyed by burning. In a situation I have lived in the soil of the garden was a strong adhesive clay. A piece of this I had thrown up in December, in ridges, to the depth of  $2\frac{1}{2}$  ft., laying it a little hollow to form a cavity underneath each ridge, and in this there was no difficulty, as the pieces might be built with like stones. In this cavity some cinders and small coals were placed, and fire set to them in March. This was spread out as soon as

burned, and dug over. In April it was trenched, mixing a quantity of road and drift sand during the process; and by the beginning of May it was in a fit state to receive seeds of any description. It was thrown into beds 4 ft. wide. The beds were raked both before and after sowing, the operator standing in the alleys between them, as I considered it injurious to set a foot upon the beds. This was sown with carrots, five rows in the bed, and a beautiful crop produced, better than had been seen for ten years previously.

*Exotic Nursery, King's Road, May 22. 1841.*

---

ART. IV. *Snails and Slugs considered with reference to Horticulture.*  
By J. G.

THE only *snail* which interests the gardener is the *Hélix aspérsa* of naturalists; for that which they have named the garden snail (*H. horténsis*) is rather a field than a garden species. The former is much the larger of the two, and has a dull shell, marked with three faint mottled brownish bands, and a white rim round the aperture; while the shell of the latter is glossy, distinctly banded with vivid colours, and the oral rim is brown.

The *slugs* which frequent the garden are, the *Limax agréstitis*, *L. cinéreus*, and *L. àter*. The *L. agréstitis* is the commonest, of a greyish colour, and from 1 in. to 2 in. long; the *L. cinéreus* is, on the contrary, from 3 in. to 5 in. in length, of a greyish or dusky colour, with darker spots and stripes; and the *L. àter* is easily known by the jet black and wrinkled skin of its back.

Snails and slugs agree generally in shape and in their other characteristics; but the body of the snail is protected with a shell, while the slug is naked. They have four tentacula placed in front of the head, and which, by a singular process of inversion, can be drawn entirely within it: the superior pair are always the longest, and they carry near the tips, but a little on one side, each a small eye, by which the animals distinguish objects nigh at hand; with the inferior pair they feel and try the road which they have to travel. Between and under this pair is situated the mouth, guarded by two swollen lips, in which, perhaps, the sense of taste may reside. The mouth is armed above with a semilunar horny jaw, placed transversely, and having its outer or cutting edge furnished with one or several serratures. Within the mouth, stretched upon a protuberant, fleshy, buccal mass, the tongue is laid, shaped somewhat like the bowl of a spoon, and consisting of a thin membrane reticulated in a manner so exquisitely regular and minute, that no one can examine it without admiration; so that we recommend it as a microscopic object to those who are fond of that instrument.

On the right side, or neck, of the slug and snail there are three apertures. "The largest, which is the respiratory orifice, is situated at the edge of the shield: the second is at the posterior and upper margin of this first orifice; it is the anus: the third is either placed directly under the pulmonary opening, or immediately behind the upper tentaculum; it is the exit for the organs of generation." (*Nunnely.*)

The skin is soft, and lubricated with a viscid mucus, which is secreted most copiously when the animals are in motion, and, running down on the ground, it serves to smooth the way, and leaves a glistening track behind, which may lead to the discovery of their retreats. They are strictly gasteropodous, crawling at a slow pace on the flat sole which constitutes their foot and belly. This foot is very muscular, and all its fibres aid in the act of locomotion; but progression is principally performed by a pair of muscles which extend from the tail to the fore part, running along the middle of the foot. On opening the cloaks, they are seen projecting on the interior surface of the foot as two raised lines, larger before than behind. By putting a slug into a bottle partly filled with water, the regular contractions of these longitudinal muscles may be distinctly seen, recalling to recollection the apt comparison of Swammerdam — "following each other like the waves and billows of the sea."

These animals are hermaphrodite and oviparous. They deposit their eggs under clods of earth, loose stones, or in the ground, in which the parent digs with its foot a circular hole, about 1 in. deep. The eggs vary from twelve to thirty in number; they are white, oval or round, about the size of a common shot, with a smooth soft skin, which is entirely membranous in the slugs, but in the snails contains innumerable minute calcareous grains always in a crystalline state, and usually of a rhomboidal figure. They are, in ordinary seasons, hatched in about three weeks after being laid, but the time is regulated much by temperature, so that in cold seasons it is greatly retarded. The young issue from the egg in the likeness of their parents, active, and furnished with every organ; and the young snails have even then a shell fitting their size and strength.

To what length of years the life of a snail or slug is prolonged has not been determined. From our own observations, we conclude that the shell of the snail is usually completed before the termination of the second year, when the animal may be said to have reached maturity. It is a gross error to suppose that the marks on the shell, which indicate the successive stages of its growth, indicate also the tenant's age; every space between two such marks being said to be formed in one season. This is not the case. These creatures are very patient of injury, recovering after the cruellest wounds; and they are capable of repairing

their broken shells, and of reproducing such parts of their body as may have been cut away in the perils to which they are exposed. In winter they retire under stones and clods, or into crevices of walls. The slugs become merely less active and more hebetous than usual, but the snails properly hybernate; and to protect them from annoyance during this dead sleep, of a winter's continuance, they seal up the apertures of their shells with a horny membrane.

[The natural uses of the snail appear to be, to serve as food for reptiles, birds, and the smaller quadrupeds, such as foxes, badgers, weasels, hedgehogs, &c. The blackbird and thrush are remarkably fond of them; and may be seen flying off with snails in their bills, and breaking the shells against stones or the branches of trees. There is some apparent reason for supposing that the worm is more useful than injurious to plants, but none that we know of as far as respects the snail.

The snail retires under the cover of foliage or some other protection from the sun and dry air during the day, and comes abroad to feed during the night, after rain, or when the weather is cloudy. It selects, in preference, tender seedling plants, or the leaves of maturer plants which have become tender and somewhat sweet by incipient decay. Snails are very fond of greasy matter, and where a snail has been killed by crushing, its remains attracts numbers to feed on it. About the end of autumn, when the weather begins to grow cold, the snail retires into sheltered places, where it will be protected from the weather during the winter. Where there are evergreens, such as the box or the ivy, it resorts to them; or if these are wanting, it will retire under loose stones, or rubbish of any kind, such as branches, spray, leaves, or litter; and, if no other covering presents itself, it has a power of burying itself in soil not too hard on the surface.

Whatever has been said of the habits of the snail will apply to those of the slug; and the natural enemies and uses of the two animals are exactly the same.

To destroy snails in gardens, the only effectual mode is hand-picking, either in the evening or early in the morning, or immediately after rain. Empty flower-pots, reversed and distributed over the surface, if an opening is left on the side, by making a small depression in the soil, will attract a great number of snails; and the more so, if some greased cabbage leaves be placed under the pots. In the course of the autumn, winter, and early in the spring, all their hiding-places should be searched, and the animals taken out and destroyed by crushing, or by giving them to swine, which are said to be very fond of them. Hedgehogs and weasels, being their natural enemies, may be kept in gardens; and poultry which do not scratch, such as the turkey, ducks, &c., may be admitted occasionally; though

no mode of subduing the snail but hand-picking is to be depended on.

Slugs in gardens are destroyed with less labour than snails; because, their bodies being comparatively unprotected, they are liable to be operated on by any caustic or bitter liquid as readily as worms. Cabbage leaves in a state of incipient decay, with the side which is to be placed next the soil rubbed over with greasy matter of any kind, or even with the bruised bodies of recently killed slugs, distributed over any surface, will attract them in great numbers during the nights; and if the blades are examined every morning, and the slugs which are found destroyed, the piece of ground so treated will soon be freed from them. Pea haulm being very sweet when in a state of incipient decay, forms a powerful attraction to slugs; and if handfuls of it are distributed over a piece of ground in the same manner as cabbage leaves, the little heaps of haulm may be examined every morning, and the slugs shaken from them, and then destroyed by watering with lime-water. Thin slices of turnips or potatoes, placed under inverted empty flower-pots, form an excellent attraction, as do the dead bodies of slugs themselves, some parts, or the whole of which are greedily devoured by the living animals. Where slugs are very abundant in a soil not covered with plants so large as to shelter them, as for example, with rising seeds, the slugs may be destroyed by watering the soil thoroughly with lime-water or tobacco-water, late in the evening or early in the morning. Abundance of water should be applied, in order that it may sink into the soil, which the slugs penetrate 1 ft. or more in depth, according to its state of pulverisation. Quicklime has been laid round plants to protect them from snails and slugs, but it soon becomes mild, and of no use as a protection. Coal ashes and sawdust annoy slugs by sticking to their feet, but they will not be deterred by this annoyance so effectually as to starve for want of food. Soot is also a great annoyance to slugs; but, to keep them from a plant, it requires to be frequently and liberally renewed. "A stout, coarse, horse-hair line, such as is used for hanging clothes out to dry, coiled round the stems of wall-fruit trees, and stretched along the wall will operate as a protection to the fruits from both snails and slugs, in consequence of the bristly surface presented to them, and which they shrink from encountering. Care, must, of course be taken that they do not get under it." (*Penny Cyc.*, *Limax.*)

No gardener ought to rest content with merely protecting his plants or fruits from snails or slugs; because, while they are in the garden, as they must live, if they are debarred from attacking one plant they will only have recourse to another. Nothing short of extermination, therefore, ought to satisfy him; and this he may accomplish by enticing the larger slugs into empty pots,

or under cabbage leaves or haulm, and by soaking thoroughly with lime-water the soil which he supposes to contain young slugs or eggs.]

ART. V. *Notice of a simple Mode of taking the Height of Trees.*  
Communicated by J. B. W.

DIVIDE a square staff (*a b*, *fig. 49.*) of about 7 or 8 feet in length into feet and inches, for the convenience of measuring the distance between the place of observation and the tree, or taking any other dimensions. Upon one side of this staff, at a commodious distance from the bottom, fix a rectangular board (*c d e f*) whose length (*d e*) is exactly equal to twice its breadth (*c d*) which breadth may be about 4 or 5 inches. At *c* and *d* fix sights, or small iron pins, and also at *g* and *e*, making *d g* and *g e* each equal to *c d*. Then, when the top of a tree is seen through the sights at *c* and *g*, the tree's height is equal to your distance from its bottom added to the height of your eye; but if seen through the sights at *c* and *e*, its height is equal to twice your distance from its bottom, adding the same height as before. In making an observation with this instrument, it ought to be fixed perpendicularly to the horizon, which may be done by means of a plummet suspended from *n*. In taking the altitude of a tree growing upon an inclined plane, you must endeavour to make your observations from a place upon a level with the bottom of the tree. If this cannot be done, direct the horizontal sights at *c* and *d* towards the lower part of the tree, and let your assistant make a mark upon it; then find the height of the tree above this mark, as before, to which add the distance of the mark from the ground, which must, in this case, be considered the height of the eye, and the sum will be the height of the tree.

June 10. 1841.

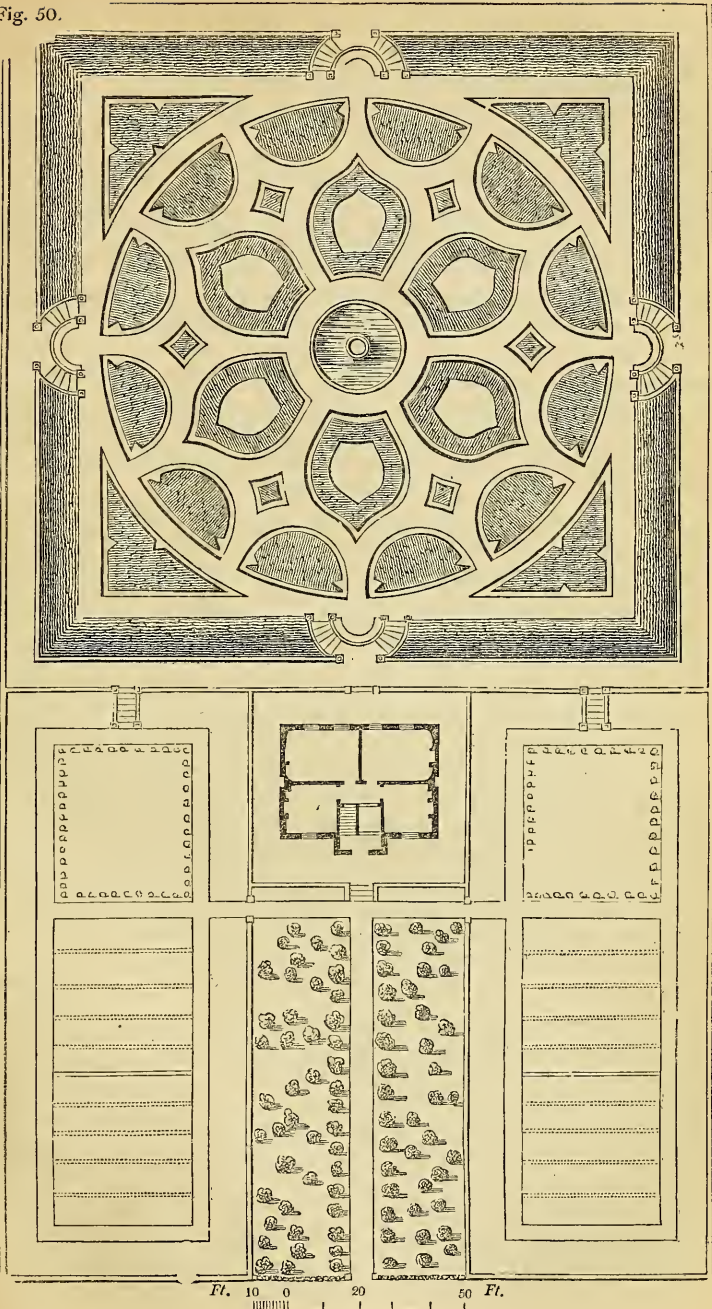

Fig. 49.  
Measuring Staff.

ART. VI. *Designs for laying out a Suburban Residence.* By the  
CONDUCTOR.

THE situation for which the design *fig. 50.* is intended is near Shepherd's Bush, and forms part of what was till lately an extensive brick field. The soil is a strong retentive clay, and its

Fig. 50.



surface is nearly level, and somewhat lower than the adjoining public road, though it admits of a certain degree of drainage.

In forming a design for laying out this piece of ground, we have adopted the geometrical style, as most suitable to all the given circumstances; and, in order to render it as open and airy as the situation will admit, we have introduced very few tall trees. All the best part of the soil we have directed to be laid on the surface of what is to form the kitchen-gardens and orchard; and the flower-garden, or rather American garden, is formed into a sunk panel, surrounded by an elevated terrace walk, from which the descent is by four flights of steps. The sloping sides of the terrace, and also the four triangular forms in the panel, are supposed to be of turf. The outer row of beds, of a semi-circular form, are intended for annuals and China roses; the six beds in the interior for rhododendrons, azaleas, kalmias, and similar American and peat-earth shrubs; and the six small beds in the angles for *Magnòlia macrophýlla*, *tripétala*, *acuminàta*, *auriculàta*, *conspícua*, and *Soulangeàna*.

The trees on each side of the entrance are chiefly fruit trees, and hence we have called it the orchard, with some hollies of different kinds, box, and yew intermixed. The walls which surround the kitchen-gardens are planted with fruit trees, the bottom of the border being rendered impervious to their roots by brick rubbish; and the wall which surrounds the terrace is planted with creepers, climbers, and roses, and with other plants requiring the protection of a wall, or improved by it, such as *Cratægus mexicàna*, *Cydònia sinénsis*, *Laúrns nóbilis*, *Magnòlia grandiflòra* and its different varieties, *Magnòlia purpùrea*, *Salisbùria adiantifòlia*, *Amýgdalus incàna*, *Arbutus Andráchne*, *Bérberis dúlcis*, *Ceanòthus azùreus*, *Chimonánthus fràgrans*, and various others. The soil of both the kitchen-garden and orchard will be rendered light by burnt lumps of clay intermixed with it in a state of powder; and that of the flower-garden rendered fit for American plants by a mixture of sand and peat.

The great object has been to lay out and plant this place in such a manner as to admit of its being kept in good order at very little expense. For this reason the edgings to all the walks are of brick moulded on purpose, and the platform on which the house stands, and all the walks throughout both gardens, are proposed to be paved with asphalte. Two grand sources of labour, and when neglected of an appearance of disorder and slovenliness, are thus avoided; and the labour may be still farther lessened by planting the steep slopes of the terrace, and the four triangles, which are proposed to be in turf, with box; which, instead of requiring to be mown at least twelve times in the course of the year, need not be mown or clipped more than once. Box thus used as a substitute for turf cannot be walked on; but in



such situations as the turf is shown in, in this design, walking on it is not contemplated.

By these arrangements, though this plot of ground contains in all above ten acres, it is presumed, as there is no glass, that it might be kept in order by two men.

---

ART. VII. *The Landscape-Gardening of F. L. von Sckell of Munich.*  
Translated from the German for the "Gardener's Magazine."

I. *General Observations on the Modern Natural Style of Gardening, with some Remarks on the Ancient Symmetrical Style.*

1. ALTHOUGH the present style of gardening is, for the greater part, governed by the rules of art, it no longer resembles that of former times, when all the forms it exhibited were obliged to be regulated by the strictest laws of uniformity.

Nature is the model for the present style of gardening; her very various and innumerable scenes which ornament the earth's surface now adorn our gardens, without the smallest trace of a slavish imitation being necessary. Art is now in unison with these natural scenes in producing many of the landscapes in our gardens, and which, when arranged with taste, form a pleasing whole; and this whole, rich in the assemblage of many foreign trees, shrubs, and flowers, and ornamented with the ancient and modern styles of architecture, forms a garden, in which Nature displays her festive attire, and which cannot be seen beyond its limits.

2. It is not my intention to make a full comparison between the ancient geometric and the present natural styles of gardening, because, in that case, I should only be repeating what many authors have said before me; I have only to observe that the natural garden, besides being in far better taste than the ancient geometric style, is much less expensive, both in its formation and future management; and is also much more useful than the ancient artistical gardens, as may be seen from what follows.

3. The piece of ground intended for such a geometric garden must, in the first place, be levelled at great expense, if nature has adorned it with hill and valley; those trees which do not stand in rows must be felled; and the winding brooks metamorphosed into straight canals; whereas the present state of gardening gratefully receives and makes use of these and all other natural gifts and beauties.

The old symmetrical style of gardening, however, such as was exemplified in the gardens spoken of by Curtius and Strabo, in the gardens of Alcinous, and in that of the younger

Pliny, has its advantages, and ought not, therefore, to be entirely set aside.

Majestic avenues, when laid out in the spirit of Le Notre, in large proportions, in populous cities, for public promenades, in which an artistical and suitable uniformity is preserved; or those forming an approach to a palace, not only present an imposing scene of splendour and luxury, but constitute a part of the lordly domain which the inhabitant devotes to the exercise and social intercourse of his guests. Thus, the pedestrian may walk about as he pleases in such long unvaried avenues without the necessity of turning his eyes to either side, which he is generally tempted to do in the case of serpentine walks, and by this means loses the aspect of the assembled whole.

4. The geometric style of gardening is also of unavoidable application in botanic gardens, nurseries, in flower and kitchen-gardens, and in orchards. Regular forms only are applicable for such gardens, because they only are generally suitable for their object.

5. In other respects, it is scarcely credible how such a taste in gardening, which displayed so many trifling and unnatural forms, could have existed, and be even followed and admired for centuries. How is it possible that the educated man could so long cherish and applaud this artistical style of gardening, on comparing it with nature to which it fundamentally belongs? [It formed a contrast to nature, and was a mark of art and refinement.] What an opposite impression must the preposterously ornamented box parterres, with their edges cut to the shape of walls, and the mutilated trees which the shears never permitted to bring forth their blossoms, have produced, in comparison with those trees of a free and natural growth, which unfolded their beautiful and romantic forms, and seemed to rejoice in their blossoms and fruit. A tree, according to the ancient geometric style of gardening, as Schiller says, "must conceal its organic nature, so that art may display itself in its natural body. It must give up its beautiful substantial form for a spiritless mass of uniformity, and its light waving growth for an appearance of solidity, such as can only be desirable in stone walls."

6. The contrast is equally great between an architectural and a natural waterfall, or between a basin or canal regularly surrounded by hewn freestone, and a free and unrestrained natural brook, of which Bernis, as beautifully as truly, thus expresses himself:—

“ Ce ruisseau, l’amour de Zephire,  
 Qui du voile des cieux réfléchissoit l’azure,  
 Et de Flore autrefois embellissoit l’empire,  
 Captif dans un bassin de marbre, ou de porphyre,  
 N’est plus si clair, ni si pur.

Esclave de l'art, qui l'enchaîne,  
 Dans sa prison superbe, il serpente avec peine;  
 Libre autrefois dans ses longues erreurs,  
 Il embrassoit, il arosoit, la plaine,  
 Et donnoit en fuyant la vie à mille fleurs.\*

7. But this comparison of beautiful nature did as little to set aside the stiff style of gardening as either Bacon or Milton in his inimitable description of Paradise, the beautiful descriptions of the gardens of Armida, or the directions laid down by Addison and Pope. It was reserved for Kent alone to venture on the first celebrated transition of laying out gardens according to the laws of nature; and he was soon followed by the most distinguished writers on the subject, such as Home, Mason, Whately, Chambers, Watelet, Gilpin, Burke, Hirschfeld, De Lille, Repton, &c., who also so much supported this new and natural style of gardening by their numerous writings, that it became, at least in Europe, the most prevailing style in use. In order to prove the difficulty of setting aside the ancient style of gardening, and replacing it by the natural, true, and beautiful style, I refer my readers to the first volume of the *Art of Gardening*, by Hirschfeld, in quarto, in which this subject is faithfully, historically, and very ably treated.

(To be continued.)

---



---

## ART. VIII. Arboricultural Notices.

### *Coniferæ.*

*THE pendulous Larch* in the garden at Henham, in Suffolk, was purchased of a nurseryman about the year 1800, being then one or two years old. At the height of eight feet it spreads horizontally, without the aid of artificial means. About thirty years since supports became necessary. The main branches, extending north and south, form a covered way more than 80 ft. in length, and 16 ft. in width; a third branch extends westerly about 8 ft.; a gravel walk being under the tree; on the eastern side it forms a perfect curtain to the ground, and the same on the western side. It is in great beauty from the 1st of May till the middle of September. — *T. B. May* 1. 1840.

*Immense Forests of Larch* cover the Aldan Mountains, and attain on them an absolute elevation, which shows how little their growth is affected by the winter's cold. Noble trees stand at a height of 3500 feet above the sea, an elevation at which it would be vain to think of rearing them in the much milder climate of the British Islands. In the same situation, snow fell heavily on the 13th of May. (*Adolphe Ermann's Travels round the Earth*; as quoted in *Athenæum*, Jan. 26. 1839.)

*A Larch* at Haining in Selkirkshire, in February, 1837, measured 11½ ft. in circumference at 1 ft. from the ground. It was planted about 1735, and, consequently, was nearly a century old. — *R. Pringle. August*, 1838.

---

\* [This brook which before reflected the heavens, and embellished the earth with flowers, become imprisoned in a basin of marble or porphyry, is no longer either pure or clear: the slave of the art which enchains it in its superb prison, it scarcely moves; while formerly it meandered through extensive plains, watering them, and giving birth in its course to thousands of flowers.]

*Aceràcæ.*

A common *Sycamore* in the churchyard of Kilmore, and which shades the grave of the persecuted Bishop Bedell, had, in 1838, 12 ft. in circumference, and extended its gigantic arms in every direction. (*Mant's Hist. of the Church of Ireland*; as quoted in the *Times* of Jan. 3. 1840.)

*Pomàcæ.*

A *Medlar* (*Méspilus germánica L.*) now growing in the pleasure-ground of Carlton Hall, Snaith, Yorkshire, formerly the seat of the late Miles Stapleton, Esq., but now of the Right Honourable Lord Beaumont, has a stem which, at the height of 4 ft., girths 3 ft. 6 in.; the total height is 20 ft., and the extent of the head from east to west is 34 ft. It bears several bushels of fruit annually, and would have been a much larger and finer tree, were it not in the immediate neighbourhood of some very large oaks. — *James Seymour. Ashridge Gardens, Nov. 1840.*

*Corylàcæ.*

*American Oaks* of various species succeed in poor siliceous soil, though but indifferently in poor calcareous land; witness the American oaks in the poor sandy soil of the Bois de Boulogne. (*Michaux.*)

*Quercus pedunculàta.*—A specimen, of unknown age, in the village of Creetingham in Suffolk, is 19 yards in circumference at the surface of the ground. The trunk is hollow, and a man on horseback may ride through it, or three cows with their calves may stand within it. In height it is not above 30 or 40 ft. — *Cond.*

An *Oak* at Fairnalie, Selkirkshire, measures, at 1 ft. from the ground, 14½ ft. in circumference, and contains 359 ft. of timber. — *R. Pringle. August, 1838.*

The *Beech* thrives in a calcareous soil better than in any other, but it must always be somewhat moist; whereas, the elm thrives in calcareous soil which is perfectly dry. (*Poiteau.*)

*Salicàcæ.*

*Poplars* succeed best in loamy soils, and next in such as are siliceous, while there are only a few that thrive in soils that are calcareous. Among the latter are, *Pópulus virginiana*, commonly called in France the Swiss Poplar. (*Poiteau.*)

A *Black Poplar* in Clifton Park, Roxburghshire, measures 17 ft. in circumference at 1 ft. from the ground. — *R. Pringle. August, 1838.*

*Ulmàcæ.*

*Ulmus campéstris* at Nettlecombe Court, Somersetshire, planted in 1770, contains 480 ft. of timber, having 300 ft. in the trunk, and 180 ft. in the top and branches. — *James Babbage. Nettlecombe Court, Oct. 9. 1839.*

A specimen of this tree at Saling in Essex is 114 ft. high, 30 ft. in circumference at the ground, 19 ft. at 2 ft. from the ground, and at 5 ft. high 17 ft. 6 in. It is a remarkably handsome tree, with the branches well balanced on each side, and in vigorous growth. Mr. Jukes, who made drawings for our *Arboretum* of the large elms in the park at Studley Royal, says, he never saw anywhere an elm so handsome as that at Saling. — *Cond.*

---

ART. IX. *Botanical, Floricultural, and Arboricultural Notices of the Kinds of Plants newly introduced into British Gardens and Plantations, or which have been originated in them; together with additional Information respecting Plants (whether old or new) already in Cultivation: the whole intended to serve as a perpetual Supplement to the "Encyclopædia of Plants," the "Hortus Britannicus," the*

“*Hortus Lignosus*,” and the “*Arboretum et Fruticetum Britannicum*.”

*Curtis's Botanical Magazine*; in monthly numbers, each containing seven plates; 3s. 6d. coloured, 3s. plain. Edited by Sir William Jackson Hooker, LL.D., &c., Professor of Botany in the University of Glasgow.

*Edwards's Botanical Register*; in monthly numbers, new series, each containing six plates; 3s. 6d. coloured, 3s. plain. Edited by Dr. Lindley, Professor of Botany in the University College, London.

*The Botanist*; in monthly numbers, each containing four plates, with two pages of letterpress; 8vo; large paper, 2s. 6d.; small paper, 1s. 6d. Conducted by B. Maund, Esq., F.L.S., assisted by the Rev. J. S. Henslow, M.A., F.L.S., &c., Professor of Botany in the University of Cambridge.

*Melastomaceæ.*

MARCE'TIA Dec. MARCETIA. (In honour of Dr. Marcet, who has written on vegetable poisons.)  
decussata Grah. cross-leaved  $\frac{22}{\square}$  pr.  $\frac{2}{3}$  s.o Pk Brazil 1840. C co Bot. 223.  
Synonyme: *Rhèxia decussata Mart. & Schrank.*

A pretty little shrub, with pink flowers, a native of Brazil, raised in Mr. Cunningham's nursery, Comely Bank, near Edinburgh. “It has been kept in the stove; but one plant, placed in the greenhouse, stood there in October without injury.” (*Botanist*, June.)

*Acanthaceæ.*

3659. STROBILA'NTHES  
scâbra Lindl. rough  $\frac{22}{\square}$  or 4 m Y India 1840. C p.1 Bot. reg. 1841, 32.

A very handsome stove shrub, with bright yellow flowers, which flowered lately at Syon. “It requires to be managed in much the same manner as an *Eranthemum* or a *Justicia*. It strikes readily from cuttings, and grows luxuriantly in any free soil.” (*Bot. Reg.*, June.)

*Thymeleæ.*

87. PIMELE'A  
spectabilis Lindl. showy  $\frac{22}{\square}$  or 3 ap. my W.Pk Swan River 1840. C 1.p.s [1841, 33.  
Bot. reg.

A showy species, with very large heads of flowers, and “smooth, rather glaucous leaves, so arranged as to form four rows along the stem.” It is easily cultivated if grown in “a mixture of loam, peat, leaf-mould, and sand;” and, though it is usually kept in a pot, “it is most beautiful when planted in the border of the conservatory.” (*Bot. Reg.*, June.)

*Orchidaceæ.*

2530. CATASE'TUM  
trûlla Lindl. trowel-shaped  $\frac{22}{\square}$  cu 1 s G.Br S. Amer. 1840. D p.r.w Bot. reg. 1841, [34.

A curious species of *Catasètum*, which flowered in the Stanhope Nursery in September, 1840. The flowers are of a dingy green and brown; and “the lip has much the form of a trowel.” (*Bot. Reg.*, June.)

*Palmæ.*

2682. ARE'CA 23570 montâna.  
Synonyme: *Eutérpe montâna Grah.* Bot. Mag. 3874.

ART. X. *On bringing the Cacti raised from Seed quicker into Flower.*  
By M. VON WARSZEWITZ, Gardener in Insterburg.

(From the *Transactions of the Prussian Horticultural Society.*)

IN 1835, about the middle of May, I had two kinds of Cacti in flower, viz. *Cactus speciosa* and *Cactus alata*. *C. alata* had

several flowers, some of which had already begun to fade; *C. speciosa* had only one flower. In order to produce fructification, I took the pollen from *C. speciosa*, with which I impregnated the flower of *C. alata*, and from *C. alata* I conveyed the pollen to *C. speciosa*.

I observed on the 6th day that both impregnations had produced good fruit blossoms, from which I finally obtained ripe seeds. In the middle of February, 1836, the fruit began to ripen, and by the middle May it was completely ripe. On the 20th of May I took the fruit, and separated the seed from the pulp. I then filled two small pots, 3 in. broad and 3 in. deep, with pure maiden earth, to which I added one part of sand, having previously put in potsherds to the depth of 1 in., so as to obtain an exit for superfluous water. I then filled the pot full of mould, pressed it down pretty firm, and then strewed the seeds, after which I covered them with a thin layer of soil. The pots were now placed in a hotbed, but in a moderate temperature; and they were always covered with a glass, in order that they might not dry up too suddenly, or be injured by the moisture dropping from the sashes of the roof, which is extremely injurious to young succulent plants. It must be particularly observed, that the pots are not allowed to get dry when germination takes place; and, in order to prevent this, I covered them every evening with wet moss, which I took off again in the morning, by which means not only a moderate degree of temperature and moisture was maintained, but the seed remained uninjured. With this treatment all the seed, even to a single grain, germinated in eight days. I kept the plants in the pots till they were a quarter of an inch high, and therefore fit to be transplanted, for which purpose I prepared the following mixture of soils: two parts of leaf-mould, one part of loam, one part of grafting clay, and one part of earthy mortar that had fallen from old walls. After these are properly mixed and put through a sieve to bring them to a proper fineness, they are put into pots 4 in. wide, and filled about  $4\frac{1}{2}$  in. high, previously provided with one underlayer of small potsherds. From four to six plants are then put in, and placed in a hotbed to obtain a higher degree of temperature. When the plants begin to grow, they must be kept uniformly moist. I kept mine so much so that the mould became covered with green moss. The plants continued healthy and beautiful, and from July to October they attained from 6 to 8 inches in height, and 1 in. in circumference. I put some other transplanted plants in a hotbed, and kept them drier. When these had remained the same length of time in the hotbed as the other plants, they were found to be very small, scarcely 2 in. high, and  $\frac{1}{4}$  in. in circumference; which fully convinced me that young plants of the *Cacti* raised from seed re-

quire a great degree of moisture, and that their growth is much accelerated by it. I observed that the young hybrid plants of *C. alata*, impregnated with *C. speciosa*, were 5- or 6-sided; and that those of *C. speciosa*, impregnated with *C. alata*, were from 3- to 4-sided.

In 1838, at the end of May, I grafted three small twigs of *C. alata* with a hybrid of *C. speciosa*, 1 in. long, and  $\frac{1}{4}$  in. in circumference, on *Opuntia vulgaris*. At first I placed the pot in the shade, and then in the course of eight days at a light window, exposed to the sun all day long. In fourteen days the twigs began to grow, and so luxuriantly, that in nine months the three grafts had formed a complete head. Thirteen of the upper shoots were from 10 in. to 14 in. long, and  $2\frac{1}{2}$  in. broad. Nine shoots, from 2 in. to 4 in. long, had appeared below, and were different from the parent stem; yet it must be observed that the grafted twigs did not retain their young appearance, because all the shoots were three-cornered below, and winged above; the twigs were thickly beset with small elevations, like *C. speciosa*, and furnished with from 14 to 19 prickles. The twigs are of a brownish red, particularly at the extremities, and the elevations from which the flowers proceed are of a dark red colour, as in *C. alata*, and from 6 to 10 flower-buds are seen on one twig. The flowers are from 3 in. to 5 in. in diameter, and resemble those of *C. alata*, but the colour is more of a clear orange red.

The hybrid *C. alata* with *C. speciosa* is now in full flower, and is very splendid, particularly when several flowers are open. I know not what kind of a flower the other hybrid will produce, but I hope soon to see, as I intend to graft it this year, so as to bring it quickly into flower.

I have ascertained that *Opuntia vulgaris* is the best stock for grafting on. I formerly grafted many kinds of the *Cacti* on *Opuntia*, such as *C. speciosa*, *C. alata*, *C. grandiflora*, *C. flagelliformis*, and *C. truncata*, on which all the grafts became healthy and strong, and were covered with flowers every year.

---

ART. XI. *On the Manufacture of Rose-Water and Attar, or Otto, of Roses, at Ghazepore.* Abridged from the "Journal of the Royal Asiatic Society of Bengal," for May, 1839.

THE rose trees come into flower at the beginning of March, and continue so through April. In the morning early, the flowers are plucked by numbers of men, women, and children, and are conveyed in large bags to the several contracting parties for distillation. The cultivators themselves very rarely manufacture.

The native apparatus for distilling the rose-water is of the simplest description, and need not be described. The best rose-

water bears the proportion of 1000 roses to a seer and a half (about a pint and a half) of rose-water. The roses are put into the water without removing the calices, and just as they come from the gardens; but an acid smell is occasionally met with in the native rose-water, which would not be the case if the petals only were used.

The attar is always made at the beginning of the season, when the nights are cool. In the morning early, the little film of attar, which is formed upon the surface of the rose-water during the night, is removed by means of a feather, and it is then carefully placed in a small phial; and, day after day, as the collection is made, it is placed for a short period in the sun; and after a sufficient quantity has been procured, it is poured off clear, and of the colour of amber, into small phials. Pure attar, when it has been removed only three or four days, has a pale greenish hue; by keeping it loses this, and in a few weeks' time it becomes of a pale yellow. The first few days' distillation does not produce such fine attar as comes off afterwards, in consequence of the dust or little particles of dirt in the still and the tube being mixed with it. This is readily separated, from its sinking to the bottom of the attar, which melts at a temperature of  $84^{\circ}$ . From one lac of roses, it is generally calculated that 180 grains, or one tolah, of attar can be procured: more than this can be obtained if the roses are full-sized, and the nights cold, to allow of the congelation. The attar purchased in the bazaar is generally adulterated, mixed with sandal oil or sweet oil. Not even the richest native will give the price at which alone the purest attar can be obtained, and the purest attar that is made is sold only to Europeans.

The natives are very fond of using the rose-water as medicine, or as a vehicle for other mixtures; and they consume a good deal of the petals for the conserve of roses, or *goolcund*, as they call it.

The same writer mentions that there are several kinds of essential oils produced in Ghazeepore from the strong-scented flowers of the district.

---

ART. XII. *On the Use of inclined Walls for growing the finer Sorts of Fruits.* By N. M. T.

MANY objections have theoretically been urged against the use of inclined walls for growing the finer sorts of fruit. As most interested in the subject are aware of the nature of these objections, I will not stop to repeat them: let it suffice to say that I consider them utterly groundless, when the walls are, in other respects, well situated; and I beg to state a few facts that led me to form such a conclusion. In 1834, I undertook the



management of some peach and nectarine trees trained upon an inclined wall, or, more properly, paved bank, that forms part of the beautiful grounds of Henry Dawkins, Esq., of Encombe, Kent; and I confess that I entered upon the task brimful of all the prejudices that had been advanced upon the subject. The wall for the trees in question was formed by paving the lower part of a high steep bank, forming a natural crescent-like concavity, the middle of which faces due south; the ends, consequently, giving a somewhat east and west aspect. The whole was perfectly sheltered by the precipitous bank, densely covered with pinasters above, and equally so by shrubs of lower growth in front; so that a more favoured spot could not possibly be selected for the growth of plants requiring intense heat to perfect their fruits; so favourable, indeed, that I should have supposed trees so situated, planted upon common or perpendicular walls, would have equally succeeded, had I not been shown the contrary, by a wall, in every respect the counterpart of the sloping one (the slope excepted), invariably ripening the fruit upon it from a month to nearly six weeks later. The fruit upon the perpendicular wall, from its truly favoured locality, is excellent and early, but still, in every respect, inferior to that benefited by an inclined surface; a fact more apparent in seasons deficient in summer heat, when the fruit upon the common wall has, in some cases, ripened partially; but in no instance, during the seven years that it has been under my observation, has there ever been a failure upon the sloping one.

Thus the so much talked of moisture, the baneful effect of hoarfrost and dew, upon the upturned blossoms, are only so many bugbears conjured up to deter from making such erections. (Why?) The supposition that they are damp, or injuriously moist, is a positive mistake. The fact is, the heat caused by the action of perpendicular solar rays upon them is often such, that ample supplies of water are indispensable to keep the foliage from being scorched up; nor does this wall, although now of considerable age, exhibit a single speck of fungus of any sort, or any of the invariable concomitants of damp. Should the position of the blossoms in such cases be more than a fancied evil, it is evidently more than counterbalanced by some positive good.

Amongst the advantages plants derive from their position on inclined surfaces, light must hold a prominent place; its influence extends to every vegetable production, and is even beneficial to the soil in which they grow. Trees naturally grow with greatest vigour at their extremities; placed upright, the evil is aggravated, and the ill-placed luxuriance goes far to deprive the lower parts of the plant of all perpendicular light; an evil that cannot affect them in an inclined position, where the

amount of light they receive is more direct, and much greater. I do not contend that such walls, erected in less favoured spots, or destitute of the accompanying shelter, would produce the same happy results; but there are many places affording such advantages, where the trial may, without fear of disappointment, be made. To be able to do so must, however, depend upon circumstances; as it is evident that the first part of the process must be finding an available bank. To raise such artificially would be attended with great expense, and, in all probability, would not answer the purpose when raised, as such bank would maintain a more variable, and, in most cases, a lower temperature, than such as are supported by so stable a body as the firm earth. It might be supposed that such banks would be well adapted for growing grapes; but, from the pendulous nature of the bunches, this is not the case. The paving of such banks is a very simple process, it being only necessary to cut the bank into the required form as smoothly as may be; then to pave it with bricks, laid flat, in good mortar: when completed, the whole to be washed over with coal tar, and the operation is finished.

Thus may be raised, at a very trifling cost (compared with what would be requisite to raise a common wall of the same extent), a surface capable of procuring to its possessor many enjoyments. The angle at which these inclinations ought to be constructed may possibly be of much importance. I have seen them, however, vary considerably in this respect, and do apparently equally well. Raised so as to meet the sun's rays perpendicularly, at a time the fruit may be expected to ripen, may possibly prove a tolerably correct guide.

*Folkstone, June 4. 1841.*

## REVIEWS.

ART. I. *Graphic Illustrations, with Historical and Descriptive Accounts, of Toddington, Gloucestershire, the Seat of Lord Sudeley.* By John Britton, F.S.A., Honorary Member of the Royal Institute of British Architects, and of several other English and Foreign Societies; Author of "The Cathedral and Architectural Antiquities," &c. 4to, pp. 46, 29 plates and 3 woodcuts. London, 1841.

THE purpose of this volume, Mr. Britton informs us in the dedication, addressing himself to Lord Sudeley, is, "to illustrate and describe a mansion which has been designed by yourself, and superintended in its whole progress of execution under your direct and special cognizance. I know not of any parallel instance where a house of equal extent, diversity of parts, richness of decoration, and harmony of arrangement, has been the work of an amateur architect. Earl De Grey, I am aware, has raised a splendid seat at Wrest, in which His Lordship has manifested an extent of architectural knowledge, and a degree of

taste, surpassing the acquirements of many professional men. Each of these houses may be truly said to reflect honour on its architect, as well as on the character of the English nobleman. It is gratifying to witness the aristocracy of our country thus laudably applying their wealth and time to encourage the artist and artizan, and to employ the labourer. If the professional architects be alarmed at the apprehension of losing a certain 'commission,' and the reputation which such noblemen might confer by their patronage, they may console themselves with the conviction that there will not be many instances of successful amateurship in their exalted profession; for the science of architecture requires too much mental labour to be successfully practised by many persons of fortune. Diligence, learning, taste, and experience, must cooperate to produce those first-rate buildings which shall deserve the praise of the discriminating critic." (p. iv.)

After a variety of remarks on connoisseurship and criticism, Mr. Britton announces his intention of giving a "full and impartial review of the architectural character of the new house at Toddington. Unlike the doating parent, who can perceive nothing but good in a favourite child, I know that Your Lordship can duly and justly appreciate both the merits and the defects of your own architectural progeny; and that you would much rather hear the language of honest discriminating censure, if merited, than that of praise, if fulsomely or indiscreetly pronounced." (p. vi.)

A long and very interesting preface takes a review of the literature of architecture, more especially during the present century, from which we make the following quotation.

"Few things are more calculated to improve or form the popular taste than published essays in works like the 'Quarterly Review;' in pamphlets, such as that by the late Thomas Hope, Esq., on Wyatt's absurd designs for Downing College; in another by George Vivian, Esq., on 'the Prospects of Art in the future Parliament House.' These comments and criticisms are of infinite service, as calculated to inform the ignorant, reprove the arrogant, induce inquiry, point out the errors of professional men and flippant amateurs, and confirm and give a permanent stamp to the productions of genius and ability. The honesty of purpose and principle, the unflinching boldness and sound criticisms, of the latter pamphlet, are truly honourable to the English country gentleman. Such persons should write often; they should not hoard up their mental wealth, but disperse it freely and frequently. Of three royal architectural gewgaws, the Queen's Lodge at Windsor, the Cottage in the forest, and Kew Palace, Mr. Vivian says 'they were equally notorious for flimsy construction and costliness. These *expensive follies* have disappeared, and although at the loss of hundreds of thousands (for the palace at Kew alone cost half a million), it is fortunate for the credit of the country that they are no longer in existence. Yet these *abominable productions* were from the leading men of the day.

"France has preceded and surpassed England in many novelties; at the present time it has set us an example which our ambition, or our shame, will at no distant time induce us to imitate. The Monarch has commanded the Minister of the Interior to appoint an 'Historical Committee on the Arts and Monuments;' one object of which is to obtain good accounts, with drawings, of all the public edifices of the country; and appropriate funds are granted to preserve or renovate the best of them. This is true patriotism, worthy an enlightened country, on which it reflects honour; whilst it gives a tacit but severe reproach to other nations whose ancient and interesting buildings are wantonly destroyed, or heedlessly neglected. Some years back I urged this subject on the attention of our own ministry; but the labours and conflicts of party engrossed too much of their time and thoughts to allow even the best-disposed amongst them to attend to such matters, or even to others, which to the enlightened Englishman seem to be essential to the national welfare and national honour."

Chapter I. is an essay on the application of ancient monastic architecture

to the modern English mansion and villa, which is pregnant with judicious criticism and remarks, and cannot fail to prove instructive to every gardener who is at all ambitious of deriving intellectual enjoyment from objects with which he is continually surrounded. We make no apology, therefore, to the reader for the length of our quotations, and we trust that our esteemed friend the author will be gratified by knowing that his sentiments on domestic architecture and landscape-gardening, by being published in this Magazine, will be perused and studied by a class of readers who are not likely to have access to his elegant, and unavoidably expensive work ; while, at the same time these quotations will prove that "Toddington" is a book as useful as it is elegant. We could wish, indeed, that it could be perused, and the plates examined, by every country gentleman intending either to plant or to build.

"The exterior of a building, like the title of a book, should not only be intelligible but expressive and apposite. It should as much indicate the true object and destination of the former, as the words of a titlepage should give a plain intimation of the contents of the latter. A painter would be reprehensible in employing dark colours and grave characters in the representation of a cheerful or a humorous subject ; and an author would be equally injudicious in writing a quaint or ludicrous titlepage to a pathetic tale, or to a philosophical treatise. So, also, the principal front of an edifice should hold out some indication, some visible mark, of its purpose and application.

"Every person, whether learned or illiterate, who looks upon the walls of Newgate or the west front of Salisbury Cathedral, will readily understand the real purpose of either building. No one would be so absurd as to call the latter a prison, or the former a church. The interiors of both these edifices are still more palpably appropriate in their respective manifestations ; for the architects knew their duty, and, influenced by sound sense and good taste, designed every part of their respective buildings with rationality and consistency.

"The exterior of the Mansion of Toddington plainly indicates its purport : it carries 'outward and visible signs' of its inward appliances. It cannot be mistaken for a church or a prison, for a manufactory or for a farm-house. The windows, doors, chimney-shafts, and other accompaniments, intelligibly and plainly show that it is the habitation of a person of rank and wealth. It is evidently the home of the lord of the domain in which it is placed ; and by its magnitude and ornamental details it demonstrates, at once, the station of its occupant and the taste of its architect. In the instance before us, these are united in the same person ; for the present noble owner of Toddington has not only furnished the means for erecting, but likewise the designs for constructing and finishing, the edifice.

"When the Gothic style first appeared in modern houses, novelty easily gave a charm to many miserable conceits, which, now that the real merits of the style are better understood, can only be looked upon with contempt. Such failures ought not to pass unregarded by the architect who aspires to a lasting name ; they are so many beacons to warn him to steer off from false taste. Most of these failures have been incurred by attempting too much. The strength and grandeur of a feudal castle, or the milder solemnity of an ancient abbey, can very rarely be imitated ; and it is quite absurd and ridiculous to pretend to such effects in a house of moderate size. True principles of taste have been sadly overlooked in many imitations of such buildings ; showy compositions have been made up of parts indiscriminately copied from castles and churches, reduced to petty dimensions, stripped of their proper details, and the naked outline feebly executed in wood or plaster.' (*Willson—Pugin's Specimens*, ii. xviii.)

"The excessive refinement of modern habits occasions much difficulty in domestic architecture. So much must be reserved for *fitting up* of a house to satisfy fashionable ideas of comfort and convenience, that a little more can be allowed for the fabric than naked walls and roof.' (*Ibid.*, ii. xxii.)

"Of modern imitations of Gothic, we may advert to a few examples ; from

which it will appear that the artists, amateurs, and gentlemen of our own time have studied the subject more carefully and critically, and have, consequently, better understood both the letter and spirit of this class of architecture than any of their predecessors since the breaking up of the monastic institutions of the country. This improvement in professional education may be ascribed to the prevalence and popularity of public criticism and discussion on works of art; to the number and beauty of the publications which have appeared since the commencement of the present century on the architectural and cathedral antiquities of our country; and to the demand for new churches, and other buildings, which have been required, in this style, within the same period. It would extend this Essay to an unreasonable length were I to enumerate and remark on a moiety of these; but it will be useful to mention and comment on some of the houses which may be considered to have contributed, in no small degree, to set the fashion, and to induce the proprietors of country estates to employ a species of architecture which is so eminently suited to harmonise with and adorn the park and landscape scenery of England.

“Mr. Willson, than whom I cannot refer to better authority on these subjects, says—‘By a judicious attention to appropriate models, a modern residence, of whatever size, may be constructed in the Gothic style without departing from sound principles of taste. Some modification of ancient precedents must be allowed, for an absolute fidelity will frequently prove incompatible with convenience; but as few deviations as possible should be gone into; and, above all, nothing should be attempted which is inconsistent with the character and situation of the place, or which cannot be executed on a proper scale of dimensions.’ (Ibid., xix.)

“‘The difficulties attending a successful imitation of the Gothic style appear to have been much less regarded than they deserve: it is asserted, with confidence, that more attention must be paid to such difficulties, both by architects and their patrons, than has generally been done, before any thing truly excellent and worthy to be associated with ancient examples can be produced.’ (*Pugin's Specimens*, ii. xxii.)

“Not only England, but Scotland, Ireland, and Wales, contain many and varied examples of modern Gothic mansions, villas, and even town-houses; some of which are at once creditable to their respective architects and owners, and ornamental to their peculiar localities. There are others, however—and the class is numerous—which are devoid of all congruity and beauty of style, and may be pronounced more petty and pretty, than skilful in design or good in detail. The architects, or rather the builders of them—true descendants of the Batty Langley school—have vainly fancied that windows with pointed arches, embattled parapets, octagonal buttresses, crowned with embrasured turrets, pinnacles, or things which they call pinnacles, constitute a Gothic building; and these frequently contained a motley mixture of castellated and monastic forms and parts. Such was the absurd and tasteless palace at *Kew*, built from the designs of James Wyatt, as well as *Belvoir Castle*, and others of his early works. Mr. Wilkins, Senior, in *Donnington Park*, Leicestershire; Mr. Holland and Mr. Carter at *Oatlands*; Mr. Nash at *Childwall Hall*, Lancashire; Sir John Soane in the *Houses of Parliament*, at Westminster; and General Durant in *Tong Castle*, Shropshire; have left in those works evidences of bad taste and ignorance of the architecture which they burlesqued. Many other architects of recent times have the credit, or rather discredit, of designing and directing buildings which have scarcely one feature of the true monastic style.

“Ashridge, the seat of the late Earl of Bridgewater, at whose expense it was built between 1808 and 1820, is among the first, if not the most magnificent, of modern English mansions. The greater part of it was designed and erected by the late James Wyatt, after whose death, in 1813, the late Sir Jeffry Wyatville was employed to alter and finish the whole. His additions and improvements were many and important; and as he had studied the subject well, and was influenced by zeal, industry, and knowledge, it is rea-

sonably inferred that some of the best features of the building are to be ascribed to him. Its vast range of buildings extends nearly 1000 feet in the north front, including the mansion, orangery, and numerous offices. The depth, or width, at the chapel, is 200 feet; but in other parts about 150 feet. The principal apartments, on the ground floor, are large and lofty, and comprise an exterior porch; an entrance *hall*, 40 by 24, and 52 feet in height; a grand *staircase*, 33 by 38, and 84 feet high; a *library*, 51 by 26 feet; a *drawing* and a *dining-room*, each 50 by 30 feet; an *ante-room*, between these, 30 by 21 feet; a *conservatory*, 108 by 20, at the ends, and 30 feet in the centre; and a *chapel*, with an ante-chapel, 76 by 20 feet. These communicate with several other subordinate rooms, also with the domestic offices, and surround several open courts. The exterior displays windows of varied forms and sizes, an embattled parapet, buttresses, and pinnacles, towers, and a spire to the chapel; whilst the interior is elaborately adorned with paneling, fan and other tracery in the ceilings, galleries, and corridors, niches with statues, painted glass in the windows, and paintings of a high class by English artists. It is built mostly of the beautiful Tottenhoe stone, with Portland stone dressings.—The furniture and fittings are designed to correspond with the building; and the whole, with its extensive and diversified park and venerable woods, forms a seat of real splendour and grandeur.

“*Eaton Hall*, Cheshire, the gorgeous seat of the Marquess of Westminster, is a large, elaborate, and costly modern Gothic mansion: it was commenced in 1803 and finished in 1825. Its architect was William Porden, Esq.; who being provided with ample funds by the wealthy proprietor, and being ambitious to surpass in richness of detail the famed works of his contemporary and rival, Mr. Wyatt, adopted the florid ecclesiastical style and ornaments of the fourteenth century, when ambitious prelates, abbots, and monarchs, erected some of those elegant churches, towers, &c., which still remain to ornament and enrich the country. Not duly considering the unfitness of this elaborate and highly wrought architecture to the wear and tear, and every-day occupancy, of a dwelling-house, the architect has produced, both externally and internally, more the appearance of a church or chapel, than of a house for the abode of a family with numerous servants. It is overcharged with ornament; it appears too light, thin, and fragile. This is more palpable in the window-frames than in other parts. Messrs. Buckler, father and son, the skilful artists, have published an interesting volume illustrative of this mansion, with ground plan, and views of its exterior and interior, with a concise descriptive account.

“The late John Nash, Esq. designed and erected several houses in Wales, Shropshire, Herefordshire, and other parts of England, in what he called the Gothic style; but it is to be regretted that there is very little to praise, or even approve, in any of those works. In altering *Corsham House*, Wiltshire, he expended a large sum of money, and made great changes to a fine old mansion. In this, however, he not only showed a lamentable want of taste, but an equal lack of good sense and discretion. In the forms, character, and adaptation of the whole design, there was not the least attempt to assimilate them to the south front, which was a fine old elevation, and which was and is preserved in its pristine simplicity and harmony of character. I am aware that the late Mr. Repton claimed this design as having been made by his son, Mr. John Adey Repton, who was at the time engaged in Mr. Nash's office.

“*Downton Castle*, Herefordshire, built by the learned R. Payne Knight, Esq., author of the interesting work on ‘The Principles of Taste,’ is certainly not calculated to reflect much credit either on his own taste in architecture, or sound judgment in such subjects. Large, round, and octagonal towers, with thin and poor machicolated and embattled parapets, are the only features of the castle; but these seem rather to belong to the scenes of a theatre than to a baronial fortress. Its sash windows are still further out of character. About the time this castle was building, or soon afterwards, R. P. Knight, Uvedale Price, and Humphrey Repton, Esqrs., were warmly contesting, in different

publications, the principles, or characteristics, of 'the picturesque,' as manifested in country seats and their accompanying scenery. Whilst the two amateur critics contended for the rugged, broken, irregular, and even ragged and ruinous, as essential constituents of that quality, and also recommended their adoption around, and in unity with a house; the professor, Mr. Repton, advocated smoothness, neatness, and symmetry, in the grounds, plantations, and buildings adjacent to the country mansion. Mr. Knight exhibited a practical illustration of his own theory in the grounds of Downton, and attempted it in his Castle, which appears to have been built under his own directions. The park and pleasure-grounds at *Foxley*, Mr. Price's seat, were also wild, romantic, and 'picturesque;' but the house was a plain old brick building. In the year 1798 I visited both these houses, and spent a most delightful day with the accomplished owner of the former. The Rev. Wm. Gilpin had lately published some popular works on '*Picturesque Beauty*,' and Walpole, George and William Mason, Whately, Morris, Marshall, and other authors, had also produced their respective essays on the same subject.

"Sir Robert Smirke has made several practical designs in imitation of the monastic or castellated architecture of the middle ages; but it is generally admitted that he has not been successful in imparting the true architectural character of either the castle or the monastery to any of his works. His two most eminent buildings are *Louther Castle*, Westmoreland, begun in 1808, and *Eastnor Castle*, Herefordshire. These certainly have circular, square, and octagonal towers, with embattled parapets, and machicolated members, with loopholes, or oilets, whilst square-headed and pointed-arched windows, with foliated pinnacles, and other details, rather belong to the church than to the castle, and do not combine well in the mansion. Both these edifices are commanding, imposing, and picturesque in their effect on the eye and imagination; but they fail to satisfy the searching and discriminating architectural critic. In *Louther Castle*, as at Eaton Hall, is an open porch for carriages. It leads to a spacious *hall*, 60 by 30 feet, beyond which is a grand *staircase*, 60 feet square, by 90 feet in height. A suite of large apartments branch off from two sides of the hall and staircase. The north front of the building is 420 feet in extent, and the south front is 280 feet.

"Mr. P. F. Robinson, author of the '*Modern Vitruvius Britannicus*,' and of other literary embellished works, made considerable alterations to an old house, near Swansea, in South Wales, for J. H. Vivian, Esq. M.P. Plans, views, and an account of his house, were published in '*Domestic Architecture in the Tudor Style*,' 4to. 1837.

"*Penrhyn Castle*, the seat of G. H. D. Pennant, Esq., in North Wales, is a large modern mansion, recently raised from the designs of Thomas Hopper, Esq., who has given to the exterior of this vast mass of building much of the true castellated character. In the largeness and solidity of forms, in the boldness of the towers, in the machicolated and embattled parapets, and in the general style and expression of the whole edifice, the architect has displayed considerable skill and professional knowledge. The ancient castle can never, however, be adapted to the demands of modern domestic comfort without great alterations, and departure from the original character of the edifice; nor can a new edifice be erected strictly in that style, to suit the habits of the present age of refinement and luxury. Sir Jeffry Wyattville, in making his vast alterations and decided improvements to

"*Windsor Castle*, found that the windows, door-ways, staircases, and apartments, of that palatial fortress were wholly unfitted for a royal residence, and therefore he remodelled and made new designs for the whole. In this extremely difficult and arduous task he manifested much knowledge, and at the same time considerable taste. Had he been unfettered, it is believed that he would have been even more successful; but when we compare what he has done with the flimsy and puerile works which he found there, of the reigns of Charles and George III., and even with the designs of his rivals, we shall find that much, very much, credit is due to him. Had all his plans for the im-

provements of this royal palace been carried into effect, Windsor Castle would be as much superior to what it is at present as it is now compared to its state in the days of George the Third. If the sums that were recklessly and tastelessly expended on the Pavilion at Brighton, the new palace at Kew, and that architectural bauble called 'the Cottage,' in Windsor Forest, had been judiciously applied to the improvements of the castle now referred to, it might have been rendered all that the good sense and good taste of Englishmen could have desired. Though much has been effected, there are many things still left undone; and although the modern architectural details are far removed from the true castellated character, it must be admitted that the whole building is more appropriate, and better adapted to the domestic accommodation of a court, than could have been obtained from any ancient castle or modern imitation.

"*Alton Towers*, Staffordshire, the mansion of the Earl of Shrewsbury, demands notice as the most remarkable seat in Great Britain, for the singularity of its scenery, and the varied incongruous buildings which are applied to the mansion, to stables, towers, a bridge, &c. As demonstrative of the eccentricity of the late nobleman, who directed most of the works, we find a Gothic bridge without any water beneath, lakes on eminences, towers in the vales, a lofty Gothic tower or temple, masses of rock raised on end and sustaining other blocks, said to imitate Stonehenge, and stables in the form of a castle. These works were commenced in 1814 by the then proprietor, who consulted many architects and also other artists, but does not appear to have followed the advice, or carried out the designs, of any one of them. The present nobleman has consequently had much to do and undo, in order to remove and remedy glaring defects, and to improve a place where nature presented many capabilities, which good taste might have rendered full of picturesque beauties and architectural grandeur. Aided by the skilful advice of Mr. A. W. Pugin, the noble owner of Alton Towers is making many and great improvements to the buildings of his seat; and we may confidently expect these will be in conformity to the principles of ancient monastic architecture.

"*Ravensworth Castle*, Durham, the seat of Lord Ravensworth, ranks amongst the most distinguished of modern Gothic mansions, and therefore challenges particular notice and comment in this place, from being chiefly executed under the directions of an amateur architect. The Honourable Thomas Liddell, son of the noble owner, has devoted some years to the pleasing and arduous task of superintending these works, and, I am well informed, has manifested both architectural skill and taste in the different parts of the mansion, which have been raised from his designs. The building was commenced in 1808, from drawings made by the late John Nash, who, according to the language of the learned historian of Durham (Mr. Surtees), adopted a 'selection from the castle architecture of various periods, not, however, too remote to be brought into contact; the various towers and façades produce pleasing combinations in every point of view.' Not having seen the building, and having vainly sought to obtain an inspection of the plans and drawings, I am unable to furnish a fuller account.

"At *Margam*, in South Wales, Mr. Hopper has built a house for C. R. Mansell Talbot, Esq., in the decorated Tudor style; and, judging from the ground plan and drawings, I am inclined to think he has been eminently successful in adapting the old forms and character of collegiate architecture to a modern mansion. The same architect has designed and erected another handsome mansion for Sir Benjamin Hall, Bart., M.P., at *Llanover-Court*, Monmouthshire, in imitation of the houses of James the First's time.

"At *Cossey*, in Norfolk, Mr. J. C. Buckler has built a large seat, with a highly decorated chapel, for Sir George Jerningham, Bart. The latter is expressly adapted for the rites and ceremonies of the Roman Catholic religion, and the whole mass of buildings, in the old English domestic character, is at once creditable to the professional talents of the architect and to the good taste and liberality of his patron.



“Mr. J. A. Repton and Mr. Blore have both been well initiated in the general principles, as well as the details, of the ancient church architecture of England. From boyhood upwards they studied and made numerous drawings of the cathedrals of Norwich, Peterborough, Winchester, York, &c., and thereby acquired a familiar knowledge of the forms, proportions, construction, and manifold details of those magnificent and interesting national edifices. Mr. Eginton, of Worcester, having studied in the same valuable school, has applied his knowledge in designing and building some good Gothic houses in the neighbourhood of Bristol. He has also shown much skill in designing a new roof to the chancel of Stratford Church, and in rebuilding parts of a church at Evesham. Mr. Augustus W. Pugin was fundamentally instructed in all the elements and principles of Gothic architecture in the office of his father, who brought up a class of pupils in that branch of art. Adopting the Roman Catholic creed, and advocating all its dogmas, as well as canons, he has been caressed and patronised by the gentry and clergy of that religion, and thence employed to build and adorn several distinguished edifices. Many other young architects of the present age have studied this class of buildings so carefully and fully as to be well qualified to design and execute new works in a good style.

“In Scotland, Ireland, and Wales, many new mansions have been built during the course of the present century, either in the castellated or monastic style of architecture. Those of Scotland are mostly of the first kind, with certain national or local peculiarities in angular and other towers, in parapets, and in the windows. The late Sir Walter Scott expended a large sum of money in building a new house at *Abbotsford*, for which he consulted Mr. Atkinson and Mr. Blore, and applied some of his own designs. It was ultimately a compound of the castle, abbey, college, &c., and was certainly picturesque in its different elevations and in plan.”

(To be continued.)

---

ART. II. *Catalogue of Works on Gardening, with some Account of those that are considered the more interesting.*

*FIRST Additional Supplement to Loudon's Encyclopædia of Plants; comprising the Specific Character, Description, Culture, History, Application in the Arts, and every other desirable Particular respecting all the Plants originated in Britain, between the first Publication of the Work in 1829, and January, 1840; with a new General Index to the whole Work.* Edited by J. C. Loudon, F.L.S., H.S., &c. Prepared by W. H. Baxter, and revised by George Don, F.L.S.

Those who possess the original work will be eager to procure this Supplement, which brings it down to the present time, and in which, we trust, they will not find a generic name omitted, of which there are, or have been, living plants in the country. There are above a thousand engravings, illustrative of this Supplement, most beautifully executed, and doing the highest credit to Mr. Sowerby and to Mr. Branston, as the text does to Mr. George Don and Mr. W. H. Baxter.

*Icones Plantarum Rariorum, &c.* By Link, Klotzsch, and Otto. Part III.

The plants figured and described in the present number are:—*Scutellaria splendens*, Labiatae, t. 13.; *Gonatanthus sarmentosus*, Aröideae, t. 14.; *Pisonia Olfersiana*, Nyctagineae, t. 15., a stove shrub from Brazil; *Odontoglossum Ehrenbergii*, Orchidaceae, t. 16., an epiphyte of humble growth, with pseudo-bulbs and white flowers spotted with brown, from Brazil; *Tropæolum Moritzianum*, Tropæoleae, t. 17., and Maund's Botanist, t. 221.; *Notylia sagittifera*, Orchidaceae, t. 18., sent from Brazil by M. Edward Otto, and previously figured in various British works.

*Specimen Book of Austin and Seeley's Artificial Stone Manufactory, New Road, London.* 4to, 18 plates. London, 1841.

Every one who has passed along the New Road, near Fitzroy Square, has seen Mr. Austin's splendid assemblage of sculptural works in artificial stone; and there is scarcely a flower-garden in any part of England which does not boast of a vase, a fountain, a sun-dial, or a statue, from his manufactory. The establishment has been greatly enlarged in consequence of the widely spreading demand, not only for ornaments to gardens and pleasure-grounds, but for finishings to buildings; such as chimney-pots and shafts, balustrades, parapets, mullions, architraves, and a variety of similar objects, which it is found may be cheaper and better executed in artificial stone than moulded on the spot in Roman cement. Mr. Austin has taken a partner, Mr. Seeley, who is as great an enthusiast in artificial stone as himself; and from their joint exertions, patronised, as we trust they will be, by our landed proprietors, architects, and gardeners, we anticipate an increased degree of architectural finish and sculptural ornaments throughout the country. The following quotation from the prefatory matter will give an idea of the nature of Austin's artificial stone, its durability, and the various purposes to which it may be applied:—

“Austin's artificial-stone is of a light tint, requires no painting or colouring, will not sustain any injury from the severest winter, and, being impervious to wet, is particularly applicable to all kinds of water-works. Its superiority is now so thoroughly established, that the most eminent architects and scientific gentlemen have expressed, in the highest terms, their approbation of its durability, and close resemblance to the real stone.

“To prevent the possibility of misconception, A. & S. beg to state that they do not guarantee any of their vases or tazzas to hold during hard frost without injury. The well-known fact of mountain rocks being frequently burst by the natural expansion of the freezing water, would prove the absurdity of such a pretension. But they boldly assert (after an experience of many years) that ‘Austin's Stone’ is waterproof, and, therefore, well qualified to hold water (not ice) for any length of time; and further, that neither heat, nor dry frost, nor snow, nor damp, will produce any sensible effect upon it. They see not, therefore, why, with the simple precaution of keeping the pipes dry from November to March 1st, the English should not enjoy what Mr. Nash, in describing the fountains of Paris, calls ‘the indescribable pleasure of running water,’ during eight months of the year. Without this trifling degree of care the strength of the basin is of little consequence, as it is quite certain that the service pipe will burst with *an inferior degree* of cold.

“This artificial stone is well adapted for the enrichments of buildings, and more particularly where repetition of ornament is required, as in the Gothic style; and when Roman cement is used for the plain work of such buildings, the ornaments (of which a large assortment, in every variety of design, is always in readiness) can be had of the same material.

“Fountains, cascades, artificial reservoirs, vases, figures, grottoes, rock-work, imitative ruins, and the most magnificent designs, can be executed in this material, of any dimensions; and it only requires encouragement to make the gardens and pleasure-grounds of England vie, in this description of decoration, with those splendid, and at present unrivalled, receptacles of art on the Continent.

“Vases and other ornaments may be made to represent the antique, as old stone can be closely imitated; and where the ornaments of old buildings are destroyed by age, they can, by this material, be restored.”

*On the Theories of the Weather Prophets, and the comparative Success of their Predictions.* By W. H. White, M.B.S., Secretary to the Meteorological Society, &c. Pamph. 8vo, pp. 16. London, 1841.

Though this tract is to be considered more as a fragment than as a whole, yet it contains matter relating to the weather which we think will be highly

interesting, if not instructive, to the gardener; and we therefore make some quotations and abridgments with that view.

“ In order to arrive at any comparative estimate of Weather Predictions, it will be important to notice briefly the principles of the theories adopted by the most popular theorists of the day. The chief aspirants for predictive fame are, Murphy, Zadkiel, Simmonite, and Hind, who shall be noticed in due order; and first, Murphy, whose fame was established upon his successful prediction in January, 1838, when he predicted that the minimum temperature of that winter would occur on the 20th of that month, which prediction was verified to the very hour: but this prediction is not so truly wonderful as it at first sight appears to us, when we reflect that England’s champion in Meteorology, Luke Howard, has clearly demonstrated, from careful observations through a period of twenty years, that the greatest cold of winter generally takes places about the time when the sun enters Aquarius, which is on the 20th of January. But the principles upon which Murphy founds his predictions are not scientific, and capable of mathematical demonstration — for he forms his predictions upon comparison of the seasons of different years — the seasons of the same year, and their principal phenomena — such as the opposite extremes of winter cold and summer heat, the equinoctial gales, and other chief periods of storm or rain. Now, if we compare the seasons of different years, what analogy do we find? Take, for example, the month of March last year, and the present, and where do we find the least analogy? — the one cold and dreary (1840), and the other (1841) brilliant and summer-like.

“ Mean temperature of 1840, 39·43 being 2·08 below the average mean.  
1841, 46·25 being 4·74 above the average mean.

“ Increase of March 1841, over } 6·82  
March 1840. }

“ Murphy proceeds to adopt a new theory; viz. — Assuming the Sun to be a globe of fire, and assuming also that the Sun is the origin of planetary and cometary temperature; he attempts to regulate planetary temperature throughout the solar system, and to show that such temperature must be the sustaining principle of life wherever it exists; hence, says he, ‘ in the absence of more direct proof, we are warranted in concluding that the *same standard of temperature* exists throughout the whole of the heavenly bodies.’ Murphy considers that ‘ *solar reflection* is the first law in physics,’ for, says he, ‘ how- ever improbable the fact of reflected action may at first appear, it has, as regards the principle of temperature, and the other local phenomena of the sun and planets, the effect of approximating and *uniting* the entire superficies of these bodies, however individually distant from each other, *on the same plane of action*. For when it is considered that the *effect of reflection* is to *reverse the scale of the action it induces on the body acted on, in the direction of the body reflected*, it will follow, that the distance of the reflecting surface on the one hand, from the body reflected on the other, can induce no difference in the local effect of such reflected action on the former.’

“ If, then, the sun has the power of equalising the temperature throughout the planetary system, we may rationally enquire, How is it that March, 1841, has been so much hotter than March, 1840? They are corresponding months, and both fall at the same season of the year; hence Murphy’s first law of physics, *Reflection*, does not hold good for two years together. But in order to set discrepancies of this kind at rest, Murphy tells us that ‘ *magnetism produces cold, and electricity produces heat*;’ — hence we were magnetised in 1840, and electricised in 1841!

“ I come now to the principles of one of the most beautiful theories ever held out to the investigation of science — a theory that is capable of mathematical demonstration, — a theory that is built upon no less a basis than that of the solar system itself — upon the system of planetary cooperation in fact, in which each planet through solar or lunar agency, acts upon the gaseous sub-

stances in the atmospheres of the others, by their angular positions. This theory has taken the name of *Astral Theory*, and is ably advocated by Zadkiel and Simmonite, the two Astral champions of the present day.

The *Astral Theory*, or *Astro-meteorology*, is founded upon certain influences, which *celestial bodies* are found by observation to have upon *terrestrial matter*, or rather upon the *gaseous substances* contained in the earth's atmosphere. Now, it would seem impossible for bodies, placed at such immense distances from the earth as the planetary bodies are, to have any influence at all upon the gases of the atmosphere, if space were a complete vacuum; but modern philosophy teaches us that space is filled with a rare and imperceptible fluid, which extends itself over all nature; pervades all space, and enters freely into all bodies; — its nature is analogous to the electrical fluid, — or electricity, in the common acceptation of the term, — and hence it forms a medium through which communication is effected between distant bodies of the universe. As this connecting medium is extremely rare, and as the planetary bodies fly through space with an amazing velocity, it is very easy to conceive that a wave-like motion may be given to this subtle fluid, which motion will continue, like the waves made in still water by agitation, following each other in rapid succession till impeded by coming in contact with a denser medium; that is, by the atmospheres of the different planetary bodies which are constantly and uniformly traversing space, with various velocities, of various magnitudes, densities, and specific gravities; hence, then, we may readily conceive the electricity of our atmosphere to become agitated, and that agitation to produce those varied results we witness from day to day, nay, from hour to hour, either in the change of temperature or pressure, the change in the direction and force of the wind, — and to the same source, too, may be traced the fertilising shower, the refreshing dew, the gentle zephyr, the pinching frost, the destructive storm, and the overwhelming hurricane, all, all are results of these powerful *electrical agents*.

“ Having dwelt very largely on the astral theory, I will now briefly glance at another theory in *name*, but *identical* with the astral theory in operation and result. I allude to the electrical theory, as found in the *Atmospheric Almanac* \*, a work which professes to have calculated the changes of the weather upon the theory of an *universal electric action, induced through the agency of the sun and moon*. This theory is founded upon the sun and moon being the only *external causes*, but that geological locality and physical position, or, in other words, the earth *per se*, is a mighty cooperating agent in their production. Now, I am willing to grant these positions to the electrical theory, but still we find such deviations from that regular series of results that would be induced by the sun and moon only, and the earth *per se*, that we are tempted to look for other agents which may have their portion in the great work of atmospheric changes; and, as each planet is but a fraction of the whole unit of our solar system, we cannot suppose that any portion can be useless in preserving the exact order of the whole machine, any more than we can part with a single finger without mutilating the whole hand: I am, therefore, strongly inclined to think that the author of the *Atmospheric Almanac* has taken into his calculations the influences of the planets, although he will not avow it; my reason for thus thinking is, that most of his *storm periods* occur at those very periods when there are many planetary aspects formed, — hence, if the sun, moon, and earth, alone are capable of affording a solution of all the problems relating to atmospheric phenomena, then is the astral theory fallacious and unscientific; but if there be phenomena which the electrical theory cannot satisfactorily account for, and that the astral theory will clearly demonstrate, then is the electric theory correct only in part, and as a *whole* cannot be received.”

---

\* By John Russell Hinde, Esq.

## MISCELLANEOUS INTELLIGENCE.

ART. I. *General Notices.*

*THE Landscape-Painter.*— But let us come to the landscape-painters, Nature's own limners and interpreters, they who should be not merely the delineators, but also the poetical translators, of all that she has of fair or beautiful, of terrible or sublime; men whose hands should be such servants to their eyes, and their eyes to their souls, that the facts and deeds of the material universe should be conveyed by them to all men in legible and harmonious characters. The landscape-painter is one of that order of Nature's priests whose duty it is to represent, as it is of others to proclaim, the order and excellence of the Creator's works; and, in this exercise of his function he is required to use the same warmth of feeling, the same ardour of imagination, the same desire to bring out and put forward all that is brightest and best in what he beholds, as the poet is, whose sphere of descriptive action is limited to words, and the extent of whose delineative powers is determined by the white paper and the flowing pen. It has been justly remarked, that the painter of inanimate objects should not attempt to give them merely as they are, that is, as they strike his own individual perception; but that there should be a certain selection of the good, and a suppression of the bad parts, which may be sure of producing an agreeable effect upon the minds of his fellow men,—that is to say, of his judges. So much of the beauty of an assemblage of objects, or of its ungracefulness, depends upon the frame of mind of the observer, that the reason of this precept is readily perceptible; and sanctioned, as it has been, by the almost uniform practice of all the greatest masters, it may now be laid down as a fundamental canon of art. The fact is, that the vulgar and uninformed mind is rarely so much touched by the mute language of the creation, the real "harmony of the spheres," as it ought to be: it is dull in perceiving the analogies, and in feeling the associations, of ideas to which a cultivated mind is all alive, when the eyes are feeding on some exquisite specimen of the Almighty's handiwork: the eye has no communion with the soul, and the ideas that are impressed become easily effaceable from the barren tablets of the memory. It is not the peasant who feels the beauty of the spot on which he lives; it is the man who is a reader, a thinker, a searcher after what is good and great; who knows how, not only to admire the glorious works of the Parent of good, but also to praise the beneficent hand that has placed him amidst them. As with men, so it is with rude or partially civilised nations; the love for landscape-painting is one of the latest tastes that spring up amongst them; and it is a branch of art that is only beginning to develope itself when the others have reached a state of maturity. "Of all modes of painting," says M. Décluse, a French critic of great renown, "that of landscape seems to be the one that most requires experience of art, and long and laborious observation of nature. Nearly all the famous landscape-painters, Claude Lorraine and Poussin among others, only betook themselves to their styles at a late period, and attained to excellence in them only after long study of nature, and when their well practised hands had overcome all difficulties of practical execution. Landscape-painting, in the course of a painter's works, holds nearly the same place as descriptive verses and moral descriptions do in those of a poet: in each case they are the results of maturity of age, of the autumn of life: landscape-painting is the last mode that is thought of being adopted; and it may be said that, in general, the descriptive style in literature, like landscape-painting in art, is only appreciated, and therefore only cultivated, at certain epochs of civilisation, when disgust for men and things leads back the mind to simple ideas, and the grand calm pictures of nature. (*Literary Gazette*, June 6. 1840.)

*On the Preparation of Timber by M. Boucherie's Method.*—All the journals have been much occupied with the valuable discovery of M. Boucherie. It is known that this physician has endeavoured to profit by the vitality which remains in trees for a short time after they have been cut down, to make them absorb liquids which penetrate with facility through their wood, and, that by making use of conservative liquids, he has communicated very important properties to the timber; but this method, however good it might be, had this disadvantage, that it could only be put in practice at certain seasons of the year, when the trees manifested the greatest vital activity. M. Boucherie now announces to the Academy that he has found a very simple method, which allows of his making use of his preparations at all seasons. According to his new method, the liquid which is to be absorbed is poured on one of the ends of a piece of wood recently cut, and after a longer or shorter period of time, according to the sort of wood operated on, the liquids peculiar to this wood are first seen to flow out of it at the lower extremity, and the preparation is complete when the liquid used for filtrating appears at the same end. This fortunate discovery is attended with excellent results; as, by making use of this method, the liquids peculiar to trees, such as resins, for example, may be extracted with great facility, and without losing anything; thus, M. Boucherie says in his letter, that in one day, by operating on two trees, he was enabled, with the assistance of two workmen, to extract 4850 quarts (litres) of liquid. M. Arago further states that M. Boucherie affirms that the wood which had absorbed liquids saturated with salts of iron presented a much greater resistance to projectiles impelled by gunpowder. We shall conclude what relates to M. Boucherie, by saying that he has found the means of making fruit absorb liquids, which he had not hitherto been able to do. To obtain this result, it is only necessary to place the fruit in a medium entirely deprived of humidity; by this means M. Boucherie has been able to make certain sorts of fruit absorb a great quantity of sweetened water. (*Le Temps*, Feb. 1841.)

*Disinfecting Night-Soil and Stable-Dung.*—Mr. Brabyn, in a communication to the *Royal Cornwall Gazette*, has pointed out the disadvantage of the common practice of mixing lime with night-soil, in order to render the latter a valuable manure. He states that by this process the ammoniacal salt, which constitutes one of the most valuable parts of the night-soil, is decomposed; the lime robs it of its carbonic acid, and caustic ammonia, a still more volatile compound, flies off in gas: thus we have got rid of all the nitrogen the organic compound contained, and the efficiency of the night-soil is greatly impaired. Mr. Brabyn recommends the following process:—To every 100 lb. of night-soil, add 7 lb. of sulphate of lime (gypsum) in powder. A double decomposition will ensue; and the result will be, instead of sulphate of lime and carbonate of ammonia, carbonate of lime and sulphate of ammonia, the latter a soluble salt which cannot be volatilised. It might now be mixed with other compost, or dried in any way thought proper, and applied to the root of the vegetable. I would also suggest that the floors of stables be strewed from time to time with a little sulphate of lime, whereby they will lose all their offensive smell, and none of the ammonia which forms can be lost, but retained in a condition serviceable as manure. In close stables the horses' health would be better preserved, and they would not be so liable to get blind as now. (*Gard. Chron.*, March 20, p. 183.)

*Hoarfrost.*—“On the localities affected by hoarfrost, the peculiar currents of air affected by it, and the temperature during its occurrence at high and low stations,” by J. Farquharson, LL.D., was resumed and concluded. The author states that he has been accustomed, for the last forty years, to make observations on the occurrence of hoarfrost, and the circumstances under which it takes place, with a view of obtaining a correct explanation of the causes of that phenomenon. It is well known, he observes, that the localities chiefly affected with hoarfrost are the bottoms of valleys, and land-locked places of all kinds, whether natural or artificial. The alti-

tude to which its effects reach on the sides of the valleys is dependent on the mean temperature of the day and night at the time of its occurrence : when that temperature is high, the lower places only are affected by the frost ; but, when low, the frost extends to much higher grounds. Hoarfrost occurs only during a calm state of the air, and when the sky is clear ; but the stillness of the air in the bottom of the valley is invariably accompanied by downward currents of air along all the sloping sides of the valley ; and it is to this fact, first noticed by the author, that he wishes more particularly to direct the attention of the Society, as affording a decisive proof of the correctness of the views he entertains, being in accordance with the theory of Dr. Wells. He finds that after sunset, in all seasons of the year, and at all mean temperatures of the air, and whether or not the ground be covered with snow, whenever the sky is clear, although there may be a dead calm at the bottoms of the valleys, currents of air, more or less strong and steady, run downwards on the inclined lands, whatever may be their aspect with reference to the points of the compass. These currents are the result of the sudden depression of temperature sustained by the surface of the earth, in consequence of rapid radiation, by which the stratum of air in immediate contact with that surface, becoming specifically heavier by condensation, descends into the valley, and is replaced by air which has not been thus cooled, and which, therefore, prevents the formation of hoarfrost on the surface of these declivities. (*Athenæum*, April 17. 1841.)

*Average Temperature at which Seeds will germinate.*—I till my garden with my own hands, and take great delight in it. It not only furnishes a wholesome exercise, but it affords me a much relished mental recreation, in watching the curious developments of the vegetable world, its recuperative powers, and, indeed, its pathology and physiology generally. Part of the experiments which I have made are intended to show at what average temperature at noon various seeds will germinate, and how many days are requisite for them to vegetate at any given temperature. Thus, I find that the Lima bean, at a temperature of 88° (in the shade) will appear above ground in seven days ; at a temperature of 62° it requires twenty days. The marrowfat pea, at 51°, requires nineteen days ; and at 74° only eleven days. Radishes vary with the temperature from six to twelve days. Thus the average temperature of any country, other things being equal, may be inferred with considerable accuracy from the periods of vegetation ; for, in looking over my long list of recorded experiments, I find a great degree of uniformity in the process of germination, in ordinary circumstances.

After various experiments, I have succeeded in ridding my peas of the bug (*Bruchus pisi*). Immediately after gathering the seed, I subject them to the action of boiling water one minute ; by this means I destroy the little grubs, or larvæ, which at this time are just below the integuments of the pea, without destroying the vitality of the seeds. If the peas remain in the boiling water four minutes, most of them will be killed, but not all ; of about forty peas thus treated last year, three vegetated, and are now growing. The corcle, I find, is more tenacious of life than the cotyledons. (*Dr. J. T. Plummer ; in Silliman's Journal*, Jan. 1841, p. 198.)

*Growth of Fig Branches without Roots.*—In the autumn of 1839, I made a basket for an orchideous plant from the branch of a fig tree ; which, when filled with suitable materials and hung up, soon commenced growing, producing leaves of a moderate size, and also roots, which penetrated the fibrous mass filling the basket. As these produced a curious appearance, and afforded agreeable shade to the roots of the plant cultivated in the basket, I allowed them to remain, and during the growing season shoots 2 or 3 inches long were formed, and ripened. This has been the case annually, and the young shoots of the present season are bearing fruit ; which is, I think, a curious and very striking instance of the very different treatment plants may endure, and still be able to complete every purpose for which they were

created. As the usual shade and moisture applied to orchidaceous plants is well calculated to maintain such a growth, without much effort on the part of any plant so unnaturally situated, I may mention that this is not the case to any extent where the plant in question is growing; it is suspended from the roof of a house containing a miscellaneous collection of stove plants, where no shade, save that afforded by creepers, is ever applied, and the growth of the fig being used as part of such shade, it is within a few inches of the glass, and is exposed to every ray. In making, or rather filling, other baskets, I deposited amongst the materials an eye or two of the fig tree; not only to produce the appearance and shade mentioned, but because I fancied that epiphytes naturally growing upon living objects might succeed better in a living mass, than in materials inert and decaying. These eyes soon vegetated, and protruded through the crevices, and are now bearing fruit; thus proving that very little support is necessary to keep in perfect health a plant generally denominated a gross feeder.—*N. M. T. Folkstone, May 28. 1841.*

*Striking from Leaves.*—In the spring of 1838, previously to his leaving Downton, unfortunately never to return, it occurred to Mr. Knight's inventive mind, that plants might be propagated from single buds and leaves only. Accordingly, he had several pots filled with a fine sandy loam; the pots were about 12 in. in diameter, to receive the cuttings, which he prepared himself. The buds and leaves were cut out, as is usually done when intended for insertion in stocks, with but a very small portion of the alburnum to each. The kinds that he operated upon were, double camellias, magnolias, metrosideros, acacias, neriums, rhododendrons, and many others. The soil in the pots having been previously pressed firmly down, and the surface made perfectly smooth, the cuttings were inserted with a dibber, so as just to cover the bud, when the soil was pressed firmly against it. The back of the leaf, lying on the surface of the mould, was fed by absorbing moisture from it. The surface of the pots was quite covered with leaves, but so disposed that they did not overlap each other; they were then gently sprinkled with water, covered with bell-glasses, and placed on the flue of a forcing-house. The sprinkling was afterwards frequently repeated, and the glasses shaded from the sun, by hanging paper over them. In a short time, the buds were seen breaking through the surface of the mould, and by the end of summer some of them had made shoots 6 and 8 inches long, especially the camellias, which were then potted off. The others, that had not made equal progress, remained as they were until the following spring, when they likewise were potted, and found to be firmly rooted. Since that time I have tried other sorts with equal success; but, perhaps, plants that have large leaves are best adapted for this mode of culture. (*S. Lauder, Downton Castle, Jan. 14. 1841; in Gard. Chron., Jan. 23. p. 53.*)

*Sawdust as Manure.*—There are many sawpits round this town; and it has been invariably found, that, when the dust is from deciduous trees, it can be rotted into a soluble mass; but, when from fir trees, it will lie for years, and reduces with difficulty, after a long period, into an earthy-looking substance; it is the resin that prevents fermentation. The best way to ferment it would be, to mix it with acid and mucilaginous substances, which contain nitrogen, an indispensable article in all fermentations; yeast, where it can be got, is the very best. Hot fermenting manure, as before recommended, is also of great avail; but, from our experience of it in swine-dung, we should think hardly sufficient for sawdust of resinous trees; for other sawdust, or for peat, it is quite sufficient. We think, all things being taken into consideration, unless acid and mucilaginous substances and yeast are easily procurable, and not expensive, the best way would be to burn the mass of sawdust, as it is likely to be from deal, that being most used. We shall then have the potash and other salts or metallic bases of the wood, and some charcoal; while the resin will be dissipated by the burning. There is not so much potash in the fir wood as in some other woods, but what there is is valuable. (*R. Lymburn; in Gard. Chron., Feb. 6. p. 85.*)



*Smoke-Flues, closed Hot-water Pipes, and Water in open Gutters, as Modes of Heating.*—The old system of heating by smoke-flues appears a most improper one, from its tendency to rob the air of the moisture suspended in it. The system of heating by the circulation of water in closed pipes is an improvement, but is also exceptionable for the same reason, or some other acting very like it. Corbett's mode of circulating hot water in open gutters appears to me to be the best yet adopted, from its throwing off moisture in proportion to the volume of heat. I consider that a moist stagnant atmosphere is more injurious than a dry one. (*S. H., Crumpsall, near Manchester; in Gard. Chron., March 20. p. 181.*)

*Objections to turning-in Snow when Digging or Ploughing.*—The evil of digging-in snow, results from the "great quantity of heat required to reduce ice or snow from the solid to the fluid state. A pound of snow (newly fallen) requires an equal weight of water heated to 172° to melt it, and then the dissolved mixture is only of the temperature of 32°. Ice requires the water to be a few degrees warmer to produce the same result. When ice or snow is allowed to remain on the surface, the quantity of heat necessary to reduce it to a fluid state is obtained chiefly from the atmosphere; but, when buried so that the atmospheric heat cannot act directly upon it, the thawing must be very slowly effected by the abstraction of heat from the soil by which the frozen mass is surrounded. Instances have occurred of frozen soil not being completely thawed at midsummer, when so buried. But this is not the whole of the evil; the moisture of the air which fills the interstices of the soil will be continually undergoing condensation as it comes in contact with the cold portions;" and accordingly these portions will be found in a very saturated condition, even after they have become thawed. (*Robert Thompson; in Gard. Chron., Feb. 6. p. 89.*)

*Canker in Fruit Trees,* Mr. Beaton is of opinion, may be prevented by grafting on stocks which it has been previously ascertained will suit the particular soils on which the trees are to be planted. "We all know," he says, "that certain plants prefer particular soils, and dislike others, but no one can tell the reason. When a young fruit tree shows symptoms of premature decay or canker, the fault, or rather the misfortune, is ascribed in nine cases out of ten to the subsoil; but this is a hasty conclusion. The worst garden or orchard soil in the kingdom produces some healthy tree; and if only one, why not more of the same species or variety? Simply, because there is only one of the stocks used in this instance which prefers that particular soil. Now, if we take pieces of the roots of this particular stock, and graft on them, we may reasonably expect that, other circumstances being favourable, they will produce trees as vigorous and healthy as their parent stock on that particular soil, though they might refuse to do so on soil which we would think more propitious for them." (*D. Beaton, Gardener to Sir W. Middleton, Bart. Shrubland Park; in Gard. Chron., March 20. p. 179.*)

*Root-Grafting.*—The practice of increasing rare plants by root-grafting is now so well understood among gardeners, that whenever any difficulty occurs in propagating a new or scarce plant by the ordinary modes, the gardener first ascertains the natural order to which the new comer belongs, and then takes the roots of the nearest allied plants he can find, on which he grafts the shoots of his new plant with as much confidence as he would the apple or the crab, and generally with as much success; hence, one good reason out of many why gardeners and all horticulturists should study the affinities of the vegetable kingdom; and hence, too, one practical illustration of the advantages of the natural over the Linnæan or any other artificial system. (*Idem; in Gard. Chron., March 20. p. 179.*)

*The Wickerwork Dahlia Protector* is made of wickerwork, and consists of an inverted shallow basket, to which is attached a tube made of the same material, through which the dahlia stick is passed, and a peg being inserted between the stick and the tube, it is firmly secured at any height required. It measures 12 in. in diameter in the widest part, and is 3½ in. in depth. From

being made of so light a material, and from its simplicity of construction, it is not easily displaced or put out of order; and the flower, not being confined within anything, is less liable to be damaged by coming in contact with any substance that would injure the petals. It requires to be painted to preserve it from decay, and if the outside be made green, and the inside white, the appearance of them would not be disagreeable, and the insects lurking inside would be easily perceived. (*C. F.*; in *Gard. Chron.*, March 20. p. 181.)

*Nets dyed Blue*, German gardeners have found from long experience to be more effective in deterring small birds, especially sparrows, than nets of any other colour. That blue should be a repellent, is no more incredible than that red should be an attractive, colour to birds; and that this latter is so, every fowler can bear evidence. Larks, it would appear, were formerly attracted to snares by red glass. (*Charles Bathurst*, Jan. 1841; in *Gard. Chron.*, Jan. 30. p. 70.)

*Woodlice among Orchidææ*.—Having seen many enquiries respecting the best mode of destroying woodlice among Orchidææ, I beg to offer the following mode. Take a potato, and cut it in half; then hollow it out, and place it on the surface of the pot of the plant infested, and you will find in the course of a few hours the potato nearly full of the insects. The above method I have tried myself with Orchidææ, these being troubled with them more than any other plant, and in the course of a fortnight I found I had but very few left.—*T. Wooster*. *Albion Road Nursery*, April 30. 1841.

---

## ART. II. Foreign Notices.

### FRANCE.

*NEW herbaceous Peonies*.—A number of seedlings have been raised by M. Guerin Modeste, 84. Rue des Couronnes, at Belleville, near Paris, of which the following six are said to be of a superior description:—*P. officinalis speciosa striata*, *P. o. anemoneflora striata*, *P. o. elegans*, *P. o. Victoire Modeste*, *P. o. pulcherrima*, and *P. o. lutea variegata*. Flowers of some of these kinds were sent to us by M. Guerin Modeste; but, though the stems were passed through corks into bottles of water, and the bottles fixed upright in a box, so that the petals could not touch any of the sides, in short, though they were packed in the very best manner, yet, when they arrived at Bayswater, every petal had dropped off.—*Cond.*

### ASIA MINOR.

*Chips of Firewood for giving Light*.—This use of firewood, cleft or torn into strips, and especially of the root of the tree, is well known, and is described in an instructive essay lately published by Mr. Arthur Aiken, "On artificial Light from solid Substances, and the Manufacture of Candles." (*Trans. Soc. Arts*, 1839, vol. iii. p. 4, 5.) But the account here given by Mr. Fellows, from his own observation, enables us to form a much more exact and accurate idea of the practice. When compared with the passages referred to by Mr. Aiken, and with those which I shall now cite from Theophrastus, it appears to me to warrant the inference, that this method of obtaining artificial light has prevailed in Asia Minor for nearly 3000 years. According to Theophrastus, the best tree for yielding touchwood was the Peuke, which is still called Peukos by the Greeks of Asia Minor, and is the *Pinus maritima* of Linnæus. (*The Rev. James Yates*; in Appendix to Fellows's *Journey in Asia Minor* in 1838.) The passage to which the above note refers is as follows:—

"I think that I have not mentioned that the light generally used in this part of the country, even in the large town of Kootáya and the other towns through which I have passed, is a chip of the fir tree. The people make a wound

in the tree, which draws the sap to that part, and the tree is then cut for fire-wood, reserving this portion filled with turpentine for candles. I was surprised to find how long they burned ; during a meal, a piece is placed between two stones, and it burns with a large flame and a black smoke for half an hour. At *Æzaani* they brought some of this resinous wood to light our fire ; and when any one of our party quitted the room, he, with his large knife (a weapon which all carry), split off a slip which served him for a candle. We met people in the streets at *Kootáya* carrying them ; but the rich use tallow candles, in the excellent and elegant lantern of the East, made of folded paper." (*Journey, &c.*, p. 140.)

## INDIA.

*Education in Travancore.* — The rajah of Travancore has done what has not been done in England, Scotland, or Ireland ; he has established a school in every village of his dominions, and he gives education to every child, male and female. There is not a child in his dominions, that has reached eight years of age, who is not capable of reading and writing. The rajah is only twenty-eight years of age, and he was educated by his prime minister, a Brahmin, who was educated by Elias Swartz, the author of *Flora Botanica*. (*Sir David Brewster, at the British Association in Glasgow* ; as reported in *Lit. Gaz.*, Oct. 31. 1840.)

*The Roses of Ghazepore.* — In the beginning of July we embarked on the Ganges, now full to the brim. If any person wishes to luxuriate among roses, let him repair to Ghazepore, where the whole country, for some hundred or two of square miles, is thickly covered with them. Rose-water and the exquisite attar of roses are, consequently, cheaper here than in any other part of India ; though the latter, when genuine, must always be a most expensive article, from the enormous consumption of roses in its preparation. It takes a prodigious quantity of the petals to make an ounce of attar ; and to produce a quart bottle would require, I suppose, a heap about as big as St. Paul's. (*Trifles from my Portfolio, by a Staff Surgeon*, vol. i. p. 184.)

## AMERICA.

*Maple Sugar.* — In a former communication I alluded to the great blessing which, thanks to a kind Providence, the people of the middle, western, and northern states enjoy, in the excellent light-coloured sugar made by them very early in the spring, by tapping the sugar maple tree. Immense quantities are annually made. The following fact on this subject is just published. "General Chauncy Eggleton has the most extensive sugar camp in the State of Ohio ; it is situated in Auburn, Geauga County. His sugar-house is furnished with fixtures and apparatus for manufacturing 500 lb. of sugar daily. A reservoir capable of containing 60 or 80 barrels receives the sap, whence it is drawn into iron pans placed over a furnace, to be boiled down, and transferred again to a large kettle for 'sugaring off.' 2700 trees have been tapped this year, though the season has not been favourable for making sugar. In some seasons he has made as much as 10,000 lb. The quantity made by him in one season, three or four years since, brought \$1250." The expense of the fixtures, apparatus, and capital is trifling, compared with the requisites for the beet sugar manufactory, at which no attempts have been made in the United States. — *J. M. Philadelphia, April 16. 1841.*

*Royal Botanic Garden, Berlin, June 11. 1841.* — Very near three years have passed since I had the pleasure of writing to you. Since that time I have seen a good deal of foreign countries. Before I left home, October, 1838, I mentioned to you that I was preparing for an expedition to the Havannah, with the intention of collecting plants, and other objects of natural history. Dr. Pfeiffer, the author of the *Monograph of Cactææ*, went with me : his intention was particularly to discover some new *Cacti*, and also shells, as he is at the same time a good conchologist. Unfortunately he did not find a

single Cactus, with the exception of *Opúntia hórrida*; but he made a very good collection of new land-shells in the short space of two months. After that time he returned home. I remained six months longer at Cuba, visited several parts of that beautiful island, and went as far as Trinidad de Cuba, on the south coast, where I got poisoned by cutting a branch of *Comocládia dícifólia*, which obliged me to return to the Havannah. My face and body swelled to an immense size, and I had to suffer a great deal. I found nothing very particular at Cuba, but yet I made a pretty good collection. The island is too much cultivated for the botanist, and not safe enough to travel alone; the Simarones, or the runaway negroes, being very dangerous. I wrote for new leave, support, and permission to visit South America; which being all granted for another year by the government, I left Havannah in the end of September, 1839, and sailed to New York, the shortest way to get to La Guayra (South America), as there is no opportunity direct from Havannah to La Guayra.

Nothing need be said about gardening in New York; the Linnæan Botanic Garden and Nurseries of W. Prince and Son, at Flushing, being the only good establishment: his collection, particularly the trees and shrubs, is pretty rich. At Philadelphia there are more love and taste for gardening. Mr. Buist has a most beautiful establishment: it contains a fine collection of good, new, and well cultivated plants. Bartram's Botanic Garden is an old establishment (since 1717), famous for some ancient and large trees, as *Quércus heterophýlla* (Bartram's oak), 40 ft. high; *Bignônia radicans*, 10 ft. high, and the stem 14 in. in diameter; *Cuprèssus disticha*, 98 years old, 60 ft. to 70 ft. high, stem 4 ft. in diameter. The magnolias and pines are very fine. My old friend, Mr. Brackenridge, was then at Rio Janeiro; he went as botanist and gardener to the United States' exploring expedition to South America.

After a short stay at New York, I sailed for La Guayra, where I soon made a good collection of Cacti, orchideous plants, &c. Some months afterwards I went to Caraccas, whence I ascended to the very top of the Cordilleras, the Silla de Caraccas, 8100 ft. above the level of the sea, where I found beautiful and rare plants, as the *Bejària gláuca*, *ledifólia*, *Gaulthèria odoràta*, and many ferns and orchideous plants. I next visited the valleys of Aragua, the famous Lake of Valencia, the finely situated town of Valencia, and Puerto Caballo, where I made good collections. Near Caraccas I found the *Galactodéndron útilè*, the cow tree (*Palo de Vaca*), but on a very different spot from where Alex. de Humboldt and Sir Robert Ker Porter found it. I drank a good quantity of the milk, alone and mixed with water and coffee, and was not able to distinguish it from common milk. It is very little used by the inhabitants. The trees were about 90 ft. high. The young plants which I sent home died on the passage.

At the end of September, 1840, I left La Guayra, with the intention of going by the Orinoko, Rio Negro, and Amazone rivers to Para, the northern province of the Brazils. I was accompanied by a Brazilian naturalist from La Guayra. I went by sea to Cumana, thence by land and river to Cumanaroa. I visited the famous cavern at Caripe (the Cueva de Guacharo), and discovered its very end. Baron de Humboldt entered only one third. M. Codazzi, who was employed as geographer and naturalist by the government of Venezuela, for making a correct map of the republic, and to distinguish her boundaries, &c. &c., explored this famous cavern nearly to its termination, but did not pass the little lake which stops the road in the cavern. When I came to this spot, the Indians told me that no person could go any further, and that those who entered the lake would be drowned. After more than half an hour's persuasion, I at last prevailed on them to go further; and with the greatest danger we passed the lake (8 ft. deep, upon soft bottom), and mounted the little hill, on the other side of which we again met with water, and could not advance more than ten minutes, because the cavern finishes there in a pointed angle, where only a little water enters, which forms the small river running through the whole cavern. The Indians were

much pleased with the discovery, as it was said amongst them that the cavern ended in the Gulf of Cariaco. The cavern is one of the finest and largest in the world. The quantity of the famous and rare Guacharo bird (*Steatornis*) is immense, yet it is very difficult to shoot many of them. The Indians prepare an oil from the young ones.

Following my journey, I went by Aragua to Maturin, both very neat villages or towns in the interior of the province of Cumana. I then embarked in a small canoe, went down the river Guarapiche, crossed the Gulf of Paria, and entered one of the many branches (*laños*) of the Orinoco. I stopped some days at Pedernales, and went up the Orinoco to Barrancas, where I got the ague, which prevented me from going any further up the river. I grew worse and worse, and was obliged to go to the interior of the province of Guayra to a more healthy place. I left, therefore, Barrancas, and went to Caroni, a small Indian village, but very healthy place, situated on the river Caroni, famous for cataracts. I recovered very slowly, the fever not leaving me; for which reason I quitted Caroni after a fortnight's stay, taking the road to Upata, the beginning of the Misiones, and thence I went into the interior as far as Tumerenco. Mr. F. Hamilton, the son of the late English consul at Angustura, a young but very rich man, and quite a Creole, invited me to his estates in the Misiones, to make there my collections. After three months' stay at his different places, I left him for various reasons. He got married at the time to a young Creole; and I, for my part, could not get well again, and also found myself terribly cheated by my fellow-traveller. I could do nothing better than start with my collections of plants, birds, and insects, which were now pretty good, for Angustura, where I fortunately soon found a German vessel bound for Bremen, in which I took my passage; and after a very quick voyage of only thirty-three days, arrived at Bremen, and soon after reached Berlin.

My collection consists of a great number of good and rare things, and a great many have shown flowers. The plants are described by Dr. Klotzsch, who is going to publish them in the *Linnæa*. During my absence great alterations had taken place in my country, and the most of them for its benefit. I found a new king and new ministers. I have had the honour to be received by His Majesty. I intend to publish my travels, and have already begun with them; but it is a hard work for me, as I have little time on my hands for such an undertaking. If there is any subject connected with my pursuits of which you want to hear particularly, please to let me know, and I shall feel the greatest pleasure in communicating any information I may possess. — *Edward Otto*.

### ART. III. *Retrospective Criticism.*

*THE Derby Arboretum.*—Some weeks since I received the Derby paper containing the long and interesting account of the opening of Mr. Strutt's Arboretum. The good people of Derby are the more obliged to Mr. Strutt, from the circumstance of his munificent gift being made during his lifetime; and he evinces his superior wisdom by so doing, in place of leaving a sum for the purpose in his will, as rich men commonly do. My object in making this remark is, to influence rich men in this country to follow his example. Stephen Girard, a French merchant or rather a Frenchman, but resident here since 1777, left, in 1832, seven millions of dollars to the Corporation of Philadelphia, for effecting a variety of purposes, and, among others, for building a college for orphans, two millions being specifically appropriated for this object. The trustees are now erecting a marble palace, which had not its equal in Athens, according to Steward's views (unless I mistake, for it is some time since I perused them). Great loss has been sustained by the funds left, in consequence of the failure of the bank of the United States to pay di-

vidends, and to the lamentable depreciation of the stocks themselves. Now, had he built the college himself, he might have enjoyed the pleasure of seeing it filled by the intended objects of his generosity; but his sole delight was to add to his immense wealth. His legatees or heirs could not moreover have interfered with his design, whereas they have commenced a suit in chancery against the corporation, on the ground that it could not legally be the heir of the deceased.—*J. M. Philadelphia, Feb. 5. 1841.*

*Plants adapted for a Conservative Wall.*—Perhaps you will allow me to set your correspondent T. B. (p. 334.) right, with respect to the list of plants furnished by me for a conservative wall. In the first place, he says “I turned with avidity to Mr. Scott’s list, but only to find that such a one as your correspondent Mr. Kent (p. 45.) requires has still to be written.” This may be true; but I did not write expressly for Mr. Kent, but in accordance with a wish expressed by the conductor, a month before Mr. Kent’s wishes appeared, and which T. B. might have done also: or, if he did not choose to do that, he might have furnished Mr. Kent with one of a more select description; as the chief end I had in view was, to record all the species which I knew from experience could be cultivated with success against such a wall as that at Chatsworth, for which T. B. has such a longing. Why did he not wish at once for the great wall of China? He would, at least, have had room, soil, and situation at command, and I the pleasure of seeing my enumeration flourish without the necessity of being crowded upon the short space of seven miles. As to the merits of a selection, that is just as it may happen to please, for the same things do not please every body: “Qui pretend contenter tout le monde et son père?” If T. B. will come out of his mask (for I hate to see a candle under a bushel, or wisdom in disguise, they have a look suspicious), and communicate with me, I will endeavour to form, under his more critical acumen, a list that may meet the wishes of Mr. Kent: but I must beg to decline any further communication with T. B. incog, lest he should turn out to be like Byron’s Junius, “really, truly, nobody at all.”

Now, with respect to *Illicium floridanum*, and *Cotoneaster microphylla* and *rotundifolia*, whatever T. B. may have found them, as regards hardiness, in his particular locality, I have nothing to do but merely observe *en passant* that I have seen all three killed to the ground by frost; as also *Erica australis* and *Sálvia aúrea* last winter in the open border; and *Kérria japónica* fl. pleno much damaged by having its branches killed back above three fourths of their length: consequently they are introduced in the list as requiring slight protection, such as a projecting coping similar to that at Chiswick, where, by the by, there is one of the finest specimens of *Cotoneaster microphylla* trained against the wall that I have ever seen. As to *Bérberis* and *Mahònia*, they are introduced as fine plants adapted for a wall without protection, and are marked as such with a dagger (†). *Bignònia capreolàta*, I allow, is quite hardy, and a most desirable ornament to a wall; it is marked in my list as requiring slight protection, which, at least, cannot do it any harm. I have only a few words more to say to T. B. as to his being able “in a few years” to furnish a list from experience, if he had the Chatsworth wall. I make no doubt but that he wants the wall, and is likely to want it, as I presume the Duke of Devonshire considers Mr. Paxton competent to make the best use of it; although Mr. Kent and T. B. would infer that it is but indifferently clothed: but this is Mr. Paxton’s affair, not mine. As to the inference that my list is not from experience, all I can say for that is, that I have then thrown away my labour, and many an hour stolen from sleep, to cater for the materials, and have been sixteen years doing what T. B. would have done better in a few. However, I did my best to present your readers with a bill of fare, which may serve some of them to glean from until T. B. provides them with one deduced wholly from experience, and which, of course, will throw into the shade the unmeritorious production of—*John Scott. Lower Tooting, June 5. 1841.*

THE  
GARDENER'S MAGAZINE,  
AUGUST, 1841.

---

ORIGINAL COMMUNICATIONS.

ART. I. *A Gardening Visit to Paris, from June 28. to August 16. 1840.* By the Conductor.

(Continued from p. 302.)

*VERSAILLES.*—We witnessed the magnificent sight of the *grandes eaux* on the first Sunday in August, and devoted three other days to the pictures and statuary in the palace, the kitchen-garden and forcing-ground, and the gardens and nurseries at the two Trianons. The idea of occupying the palace as a national museum, open to all France, and, indeed, to all mankind, every day in the year, was in accordance with the spirit of the age, and such as might have been expected from a man of so much sound sense and enlightened humanity as the present king. It is a sort of consecration of the labours of Louis XIV., or rather of his age, which almost reconciles us to their enormous expense. The public gardens were in good order; but the geometrical beds did not appear to us quite so well supplied with flowers as those in the Palais Royal and at Fontainebleau. One scene, however, in the lower part of the garden, made ample amends, by being filled up with geraniums, petunias, fuchsias, and other plants in pots, after the manner of Baron Rothschild's garden at Surenne. This part of the grounds, about an acre in extent, is laid out in the natural manner; and the turf was green, and in very good order. It is surrounded by an irregular border of trees and shrubs, very well broken into recesses and projections; and the interior is varied by groups. All these bays, and the recesses, and also the detached groups, were bosomed up with plants in pots, more especially scarlet geraniums and white petunias. The display is brilliant, and quite different from anything ever seen in England. It is greatly admired by the French; but we could neither at the time, nor on reflection since, bring our mind to approve of it. Our taste is formed on a different model, that of the secluded lawns and glades of English pleasure-grounds; such as are met with, for instance, at Kenwood near Hampstead, at Pain's Hill, and a few first-rate places. Our

opinion, therefore, is, that those who admire scenery of the kind described as existing at Versailles, Surenne, and, more or less, at all French villas of any note near Paris, have had their taste formed on a peculiar model, and one which is deficient in truth and nature. If we continue to insist on this opinion, it is because we wish to have it questioned and discussed by others as well as by ourselves, in order ultimately to arrive at the truth.

Near the Grand Trianon, a few acres of ground have recently been laid out in the English manner, by M. Massé, the Director-General of the Gardens of the Crown, by the king's orders. On objecting to the round clumps, and stating that, as no fences were required, the same effect might have been much better produced by single trees placed at irregular distances, so as to form connected groups, M. Massé informed us that he said so to the king, but that the latter insisted on having clumps, as being in better taste! We could not help thinking, at the time, that the king had probably taken his ideas from that passage in one of Sir Walter Scott's reviews, in the *Quarterly Review*, where he echoes the sentiments of Sir Henry Steuart, in which the latter says, "If masses must be planted in parks . . . what shape can be adopted more generally pleasing than that of the circle, or the oval, or some modification of it?" With great respect for the memory of Sir Walter Scott, we cannot allow that he set an example of good taste in architecture or gardening, either in his works or in his house and grounds. We have no doubt his expressed sentiments in the *Quarterly Review*, got up for effect, as most of his reviews are, have done harm. His assertion, in the *Quarterly Review* for 1827, that the Scotch fir commonly sold in nurseries is an inferior variety brought from Canada, could never have been made by any person who had the least practical knowledge of the pine and fir tribe. Not only is the Scotch pine not a native of any part of America, but there is no American pine whatever sufficiently hardy in this country to produce cones in the immense quantities which the "mean-looking tree" from Canada, which, Sir Walter Scott says, "is called *par excellence* the Scotch fir," is said to do. The just celebrity of Sir Walter Scott as a novelist and poet, however, led the public to place implicit confidence in his statements respecting landscape-gardening and planting, of the principles of which he may be said to have known nothing.

The grounds of the Trianon bear, perhaps, as close a resemblance to those of the retired parts of an English villa as any in the neighbourhood of Paris; but they are spoiled by too many walks being seen at the same time, which detracts from the idea of seclusion which ought every where to prevail in such a scene. For this reason, in all imitations of the natural, or English, style,



there should seldom be any other walk seen by the spectator than that on which he is walking. This may always be contrived by slight elevations of surface near the walks, or by the judicious interposition of evergreen shrubs, as we have hinted at in the description of Garden Cottage, Cheshunt, in our preceding volume. We do not say that there are not many cases in which the glimpse of a walk in an inviting situation at a distance may not be desirable to invite the spectator onward; on the contrary, we hold it as a principle that glimpses of walks, of seats, temples, ruins, remarkable trees, mounts, or pieces of water, should frequently be obtained from the walks of extensive grounds, as helps to the imagination. Every straight walk in the geometric style leads to a terminating object distinctly seen; and every winding walk in the natural style exhibits nothing that gives the idea of termination: it "still begins, but never ends."

It is remarkable that the name of the Englishman who laid out the gardens of the Petit Trianon, in the time of Louis XVI., is unknown. The queen, Marie Antoinette, is said to have dressed herself like a peasant, and spent whole days in that character in these grounds, occupied with her dairy and with poultry; partly a proof of her unfitness for her situation, and partly of the unfitness of the royal office, as it then existed, for the condition of humanity. (See Miss Martineau's admirable little work, *The Peasant and the Prince*.)

In the collection of trees and shrubs we found a few interesting plants; but, on the whole, it was less complete than we expected. Two or three of the trees which formed part of the *E'cole* of Jussieu still exist, particularly two fine specimens of *Quercus Pseudo-Sùber*. A cedar of Lebanon, 50 years planted, is 65 ft. high; *E'phedra monostàchya*, 5 ft. high. (M. Massé informs us that there is one at Toulon 20 ft. high, where it is called *Barbe de Jupiter*.) *Pópulus heterophýlla* grafted on *P. fastigiàta*, it is said, forms a more durable little tree than when on its own roots: the stock increases much faster than the scion. A hybrid has been raised here between *Jùglans règia* and *J. nìgra*, which is very distinct, both in the fruit, leaves, and smell: it nevertheless matures fruit, from which young plants have been raised; a fact which, with others we met with in the Bois de Boulogne, induces us to think that several of the American species of *Càrya* are hybrids produced by accidental crosses. Many young plants have been raised of *A'lnus cordàta*, which vary so much in their leaves that several distinct varieties might be selected: one resembles the *A. subcordàta* of Meyer, another the *A'lnus commùnis*. There is a curious variety of *A'bies commùnis*, about the size of the *Araucària imbricàta* at Kew; and with the branches not frondose, but having branchlets depending in curves like those of the plant referred to; and with

leaves similarly disposed, but much smaller. Altogether it is a very remarkable plant. It has received the name of *Abies communis mucronata*. *Pinus Cémbra* succeeds well grafted on *Pinus sylvestris*. We had here a proof that *Pinus romana* of Loddiges and the Horticultural Society's Garden is the *P. calabrica* of Vilmorin, Poiteau, and other French botanists. *Cunninghãmia lanceolata* is above 15 ft. high, in a vigorous thriving state, and stands out every winter without the slightest protection. This plant suffers less during the winters of Paris than during the London winters, though the former are so much colder: the reason probably being, that the air of Paris is so much drier than that of London, and also that the wood is ripened better from the hotter summers. It seems very probable from this, that the Mexican pines could stand the open air well in this part of France; an opinion which is strengthened by the fact that *Pinus australis* (*P. palustris Hort.*) thrives admirably in the Bois de Boulogne, where, 5 or 6 years planted, it is nearly 10 ft. high. About London, and at Dropmore, it requires protection, at least in severe winters. The purple beech, grafted on the common beech, is planted at the base of a south wall, and the shoots are trained against the wall, in order to procure a straight stem and rapid growth. *Amýgdalus incana*, against a wall, is 12 ft. high. The common Scotch rose is here clipped into the form of cones, 6 or 8 feet high. *Quercus sessiliflora incana* is the same as *Quercus pubescens Lod. Cat.*, and *Quercus sessiliflora pubescens Arb. Brit.* *Quercus australis* here is a variety of *Quercus Ilex*. *Acer créticum*, from the Morea, has broad leaves, and is the *Acer coriaceum* of *Lod.*, also raised from seed by M. Camuset in the Jardin des Plantes. *Acer monspessulanum latifolium* is the *A. lobatum* of the Jardin des Plantes and of *Lod.* *A. trifidum Thouin* is the *A. rotundifolium* of the Jardin des Plantes, and *A. O'palus* of *Arb. Brit.* The Lilas Charles X. is a variety of the common lilac, with the flowers in compact racemes.

In the reserve, or private, flower-garden, near the kitchen-garden at Versailles, we observed extensive supplies of plants for the borders, and for decorating the rooms of the palaces during the winter season. Immense quantities of violets, lilies of the valley, roses, and other flowering or fragrant plants, are kept in pots ready to be forced in low pits heated by dung, smoke in earthenware tubes, or by hot water in earthenware pipes or in copper tubes.

The kitchen-garden at Versailles is one of the most spacious in Europe, and we hope it will not be lost sight of in forming the new one at Windsor Castle. It is square in form, contains about 12 acres, and is surrounded by a broad terrace, 4 or 5 feet higher than the area of the garden, and which terrace is occu-

ped by a broad carriage walk, and the border for the fruit trees which clothe the surrounding walls. Exterior to this garden, at one angle, is a forcing-ground; and at another is a small garden, containing the house which was occupied by the celebrated Quintinie, the architect of the garden, and the head gardener during the time of Louis XIV. The walls are well covered with pear trees, peaches, and vines; and in the borders throughout the gardens all the best French and Flemish pears are cultivated *en pyramide* or *en quenouille*, in the manner adopted in the Chiswick Garden. One of the crops most extensively cultivated is the alpine strawberry, with which the royal table is furnished, from the open garden, from June to October, and great part of the rest of the year from hotbeds. These strawberries in France are preferred to all others; and deservedly so, as we think, as far as flavour and duration of crop are concerned (see p. 266.). The plants are abundantly supplied with water, which is given them overhead even during the hottest sunshine. On remarking on this to M. Massé, he observed that it did them no harm whatever, and that the extent to which watering was obliged to be carried in the garden was so great, that it was performed during the whole day. The same thing takes place in all the florists' gardens about Paris. The earlier crops of grapes, peaches, plums, &c., had been gathered; but there were succession crops in an excellent state. The kinds of grapes forced are chiefly varieties of chasselas; but the muscats are cultivated for the later crops. The most remarkable circumstance, however, connected with the royal kitchen-garden at Versailles, is the mode of cultivating the pine-apple, and the success which has attended that mode (see p. 200.).

There is a house devoted to the *Mûsa*, some plants of which have large spikes of fruit; and, if its flavour should be liked in France, it will form a most valuable addition to the dessert, as it can be cultivated in large quantities with the greatest ease. We found here many dozens of pine-apples ripe, or nearly so, and others in every stage of progress. Many of the full-grown Enviles were as large as any which we have seen during the time of Plimley in the forcing department at Kensington; and many of the plants had large fruit on their suckers, such as we have seen at Wentworth House, and other places in Britain, and in the royal kitchen-gardens at Munich, as described by one of the royal gardeners there in our volume for 1829, p. 427. M. Massé, whom we believe to be the third successor of Quintinie, holds the situation of Intendant of the Gardens of the Crown, for which, from his botanical acquirements and great experience, he is eminently well adapted, showed use very attention and the very greatest kindness; and gave every explanation that we required, during two of the three days that we devoted to Ver-

sailles. We take this opportunity of returning our best thanks to M. Massé, and to his foreman in the forcing-ground, who furnished us with a plan of a boiler of his invention, well adapted for heating where the fuel is of wood. To the foreman at the nursery at the Trianon we are also equally obliged.

Close to the kitchen-garden at Versailles are the grounds of a villa, which had been laid out and built by Louis XVIII. when dauphin, for one of his mistresses. There is an immense cave, or grotto, formed of stones brought from the Forest of Fontainebleau; and in front of it a lake, of nearly an acre, surrounded by glades of lawn and wood; the whole in a state of utter neglect. We did not go into the kitchen-garden or the house. This property, we were informed, was sold during the first revolution for a smaller sum than would now be procured for the lead pipes which convey the water to the grotto, if they could be dug up. We enquired if Louis XVIII. had ever come to visit this villa after the restoration, and were answered in the negative. This place, when we saw it, was on sale; and by an Englishman of taste, and a little property, it might be made a terrestrial paradise.

*Neuilly*, the private property of the king, is an extensive place, with a flat surface; and, as it appeared to us, rather too much cut up with walks, roads, and trees. There is no breadth of effect any where. There are one or two good points about *Neuilly*, however, which it may be worth while to mention.

The unity of a willow scene, as seen from a wooden bridge, and the greenness of the lawn near the house, are both worthy of notice. The house itself has neither dignity nor elegance, nor can we say that there is any display of good taste within the domain. Nevertheless, we love the place on account of the esteem and respect which we have for the owner and his family. The house is approached by carriages on both fronts, a practice general on the Continent, but happily rare in England; because it strikes at the root of all privacy and seclusion. In every country house in England, from the smallest cottage to the most magnificent palace, there is always a public and private front: the former, or entrance front, exhibiting a porch or portico, at the door of which the stranger knocks, and to which carriages drive up; and the garden, or lawn, front, commonly on the opposite, but at all events on a different, side of the dwelling, to which no carriages or horsemen, nor no stranger on foot, can approach without the knowledge of some part of the family. Hence, on this lawn or garden front, ladies and children may walk out at all hours of the day, unseen and undisturbed by visitors who may call at the entrance-front. In our opinion, there can be no true enjoyment in a country house that has not

a private front, as well as a public one: but we go further, and say, that even if the private carriages and horses of the family are allowed to come up the private front, as they are at Neuilly, the peculiar privacy of that front is destroyed.

The road to the principal entrance-front at Neuilly is a straight avenue between two straight parallel beds of flowers: which, at the time we saw them, were filled mostly with geraniums, peonias, dahlias, and standard roses. Strange as it may appear, these beds of flowers are not so offensive to us as clumps and borders of shrubs bosomed up with the same kinds of flowers: because in these beds they are not in pots, but turned out in the free soil; and not being shaded by trees, or mixed with them or with common shrubs, they have a much greater air of truth. The plants in these beds are so far apart that each takes its particular shape; and some portion of the soil being seen between them, no doubt is left on the mind of their being planted in it. The plants in pots which are employed to bosom up clumps, on the other hand, are crowded together in such a manner as to present an unvaried surface, and a mass of colours pellmell, as Chevreuil observes, which, compared with that of plants growing apart in a border, is deficient both of variety and truth.

In 1828 there was a tolerable collection of trees and shrubs in the nursery-ground here, which we were anxious to examine, expecting considerable additions to have been made; but instead of this, the numbers were considerably diminished by the ravages, as it was stated to us, of the ver blanc. We found *Sophora japonica pëndula* beautifully in flower; some seminal varieties of *Acer platanoides*, *obtusatum*, and *monspessulanum*, obtained from M. Audibert of Tarascon; and near the river an old plant of *Ulmus effusa*, believed to be the largest in the neighbourhood of Paris. The tree, at some former period, had been cut over, and there are now three immense trunks proceeding from the same base. The wood is said to be much heavier and more durable than that of the common elm. Among the greenhouse plants we found the *Philippodendron règium* 10 ft. high, with the habit and appearance of the poplar-leaved birch; but it is far from belonging to that family, as supposed in our volume for 1840, p. 5. From a dried specimen kindly given us by M. Jacques, the royal gardener, it appears to be much nearer *Urticacææ* than *Amentacææ*.

*St. Cloud.* — The walks and roads here, as at Versailles and Meudon, were quite free from weeds and smoothly raked. The grass, also, was not badly kept, considering that it is a mixture of unsuitable species, among which spring up numerous salvias, plantagos, and other broad-leaved plants. In the hanging woods, the undergrowths have all been cut down, leaving the surface quite naked and black from the absence of vegetation.

Had the surface of the ground had any character of regularity, and had the trees been at such distances as to form an open grove, and to allow the grass to grow beneath, this clearing away of the undergrowth would have been justifiable, as creating an artificial character well adapted to the geometrical style; but at present the trees are too close to admit of the growth of grass, and the surface is too irregular to admit of being reduced into regularity without rooting up the trees in some places, and burying them too deeply in others. All that can be done, therefore, with a wood, under such circumstances, is to cover the ground with undergrowths, and especially with evergreens, such as yew, holly, box, &c., thinning out the trees to such an extent as to admit of this undergrowth growing with vigour. We were anxious to know what was intended by clearing away the undergrowth, but could not find the head gardener, and, for the same reason, we were unable to see the king's private garden. We afterwards learned that it had reference to the frequent attempts on the life of the king; undergrowth being favourable to concealment.

Here, as at some other royal palaces, the roads and courtyards appear disproportionately large for the buildings, and the latter are deficient in architectural display, and particularly in light and shade. We should be inclined to try, if possible, and narrow the roads and courts by broader margins of turf, and where the courts are paved with stone, we would substitute wood or asphalte.

*Sceaux.* — In our ninth volume we have noticed several villas at Sceaux, and especially those of the Admiral Tschigoff and the Countess de Bruce; but both these, and all the others that we then saw, have changed proprietors. The excellent effect of grouping the trees in the villa of M. Sartorius is visible from the public road; and presents a succession of scenery very different from that of a villa having only the same number of species as this one, but, instead of these species being grouped so as to show one kind always prevailing in one place, presenting them everywhere indiscriminately mixed, so that one part of the plantations and shrubbery has exactly the same appearance as every other.

*Verrières.* — The villa of M. Vilmorin is interesting as a beautiful rural retreat, kept at all times in the highest order, and also as exhibiting specimens of most of the horticultural and agricultural seed-bearing plants which are to be procured in the commercial house of Vilmorin, Andrieux, and Co. The collection of wheats was very numerous, and also those of barleys, peas, kidneybeans, and, in short, we may say, of every plant of which seeds are kept in the seed-shops, as well as of potatoes of different kinds for their tubers. Among the newest

vegetables was *Scólymus hispánicus*, the roots of which we had an opportunity of tasting at M. Vilmorin's table, and found them equal to those of scorzonera. In the kitchen-garden there is a very full collection of gooseberries, which was sent to M. Vilmorin by the Horticultural Society in Mr. Sabine's time; and, though no care had been taken to supply the plants with water, yet the fruit was nearly as large as in England, probably in part owing to the greater coldness of the present season. Among the trees and shrubs we found several species of American oak growing with great vigour, more especially *Quércus álba*, which is rare in France, and very seldom seen in a healthy state in England. *Q. Talúzin* is also here in great vigour; and *Q. E'sculus*, known as *Q. apennìna*, with various others. There are a number of stools of *Cratægus apiifòlia*, raised from seeds received from Washington, some plants of *C. cordàta*, with other American species. We tasted an excellent late cherry called Napoleon, which does not appear to have been introduced into England; and M. Vilmorin directed our attention to another wild cherry with pendulous branches, the fruit ripening late, and the tree an extraordinary bearer. In the shrubberies on the lawn are two plants, 10 or 12 feet high, and of as many years' growth, of *A'cer créticum*; the one with scarcely any leaves lobed, and the other with scarcely any leaves entire. In the woods M. Vilmorin found *Ulmus montàna L.*, known here as *Ulmus campéstris latifòlia*, with the soft wood of the young shoots of a dark red, as already mentioned; and, from seedlings of *Robínia glutinòsa*, he found the common *R. Pseùd-Acàcia* with shoots not glutinous. These facts only deserve notice, because it has been hitherto customary to give herbaceous plants only the credit of coming true from seed. Our belief is, that *R. glutinòsa* is only a variety of *R. Pseùd-Acàcia*; and, therefore, we are not surprised that seedlings raised from it should occasionally revert to the original species. It is not, however, the less desirable tree for being a variety; and, in short, we believe it will be found that all the hardy plants best worth culture, for use or ornament, ligneous or herbaceous, will be found to be more or less deviations from the wild species; and almost all the handsomest very distinct varieties to be cross-breds, and even hybrids.

*Belleville.* — The village of this name is situated on some of the highest ground in the neighbourhood of Paris; and, being the resort of the working classes on Sundays and other holidays, it is covered with small country houses and guinguettes, or what in England would be called tea-gardens. The common lilac is here cultivated on a large scale for the sake of the flowers, which are gathered and sent to the flower-market. We visited the villa of M. Audot, the publisher of the *Bon Jardinier*, and him-

self the author of several useful works on gardening, and were very hospitably and kindly received by that gentleman. M. Audot's garden, which may contain an acre or upwards, is interesting from the number of objects it contains, and from the good account to which it is turned, both in an ornamental and useful point of view. There is a garden-house as a study, several plant-houses, pits, and frames, and a small farmyard for poultry, rabbits, pigs, a cow, &c. In short, there are few things belonging to a small suburban villa which it does not contain.

*The Elysée Bourbon, and the Hotel of the English Ambassador,* are street houses, with parallelogram gardens, of about a quarter of an acre in extent each. The middle of the ground is hollowed out lengthwise, and the sides raised and undulated, so as to produce a very good effect; and, these sides being planted, a shady walk is procured under trees and among shrubs, of which, had care been taken at the time of planting, there need not have been more than one or two of a kind. Nothing more can be made of limited pieces of ground of this kind without introducing either the Italian terraced, or an architectural, garden, or a system of walks crossing each other in grotto-like tunnels, by which any small place with a dry subsoil may be made to appear many times larger than it really is.

The only defect in the two gardens mentioned is, that they are not united architecturally with the house. Mr. Gordon, the gardener of the English ambassador, keeps up a considerable collection of greenhouse plants, and has the whole place in good order. With the exception of a small room, silvered instead of gilt, there is nothing in the interior of the Elysée Bourbon deserving of particular notice. The meagre finishing of the large dining-room, one end of which is a mirror without a frame, gives the idea of coarseness and want of taste. The library is a very small room; and what is curious is, that the only bookshelves it contains are in a gallery to which there is no means of ascending but by a trap-ladder, which is shut up in a closet, and which could not be used either by a lady or an elderly person of either sex.

*Nurseries and Florists' Gardens.* — The garden of M. Tripet Leblanc, 19. Avenue de Breteuil, and that of M. Fion, Rue des trois Couronnes, we found both richly stocked and in excellent order. In the former there are extensive collections of auriculas and carnations; and, indeed, an extraordinary degree of attention is paid to every description of florist's flowers, as well as to many kinds of culinary vegetables and fruits. The garden, though, as it were, in the heart of Paris, yet from being in an artificial hollow, and being surrounded by banks covered with trees and bushes, might be taken for a garden in the suburbs. The family of Tripet have been celebrated for their tulips for three



generations, as appears by an article in the *Annales de la Société de Horticulture de Paris* for 1838, p. 355. The garden was originally in the Champs-Élysées, and was celebrated there for its tulips and hyacinths about the middle of the last century. The ancestor of M. Tripet, like the great-grandfather of M. Vilmorin, was of a noble and wealthy family, and in both cases resorted to culture and commerce, partly from necessity, and partly from choice. The *jardin d'hiver* in M. Fion's garden, or conservatory, as it would be called in this country, was now wholly uncovered; but the plants had not yet recovered from the effects of the sudden change from the protection and shade of glass to the direct influence of intense solar light. We observed the walks bordered with *Lycopodium denticulatum*, as at Alton Towers.

*The Jardin des Plantes* has undergone important changes since 1829, and is now far more complete and in better order than ever we saw it. We were kindly shown through the Museum by Professor Audouin, an enthusiast in everything respecting insects, who showed us his mode of feeding them, each on its appropriate species of plant, under glass bells; the shoots on the leaves of which the insects feed being protruded through the piece of pasteboard on which the bell stands, into a glass of water, by which means the leaves are kept perfectly fresh. M. Audouin is rearranging the insects in the Museum according to their natural families and genera; and, by means of pieces of paper of different colours, he shows at a glance the part of the world of which the insect is a native. A large building has been erected for the geological collection and the library. The building, in our opinion, has little to recommend it exteriorly, and it appears too much ornamented within for a scientific collection; but of this building we shall speak in a future article. The library is well arranged; and there is here an arrangement of pamphlets and essays or articles on subjects of natural history, such as exists, we believe, no where else in the world. In catalogues such as that of the Banksian Library, the contents of pamphlets and transactions, &c., are analysed and classed together, so that they can be readily referred to, if the books are in the library; but here the essays and pamphlets themselves are taken to pieces, and bound up according to the subjects. The merit of this extraordinary degree of knowledge, care, and labour, is due to M. Lemercier; who informed us that two copies of each pamphlet or article is necessary, and that when these could not be procured in type, then, as a substitute for one copy, he used manuscript. Labours of this kind may be compared to railroads to science; since it enables the student of any one topic to read everything respecting it in less than the time that would

be required to open the books in which it was treated, not to speak of the risk of overlooking some of these books.

The plants under glass in the Jardin des Plantes want the greenness, succulence, and vigour of growth of plants similarly circumstanced in England, doubtless owing to the dryness of the air, more intense solar light, and a mode of management which has not for its object to promote vigorous growth and succulence. Indeed, if this were the object, the plants would suffer still more than they do when turned out into their respective places in the general arrangement, because the changes in respect to atmospheric moisture and solar light would be still greater than they are. We spent three entire days in examining the hardy trees and shrubs in this arrangement, and those in the nursery, under the care of M. Camuset. The following list includes plants which we thought in some way or other remarkable; the order is that in which they are planted in the garden, and the authorities after the names are those on the garden labels.

*Laurus Benzoin*, as it ripens its wood, stands the winter here better than it does about London.

*Atraphaxis undulata* is hardy. *A. spinosa*, 5 ft. high, covered with flowers, a truly beautiful object, and rare.

*Brunnichia cirrhosa* *Gart.*, a tendriled climber, a native of Carolina, is 12 ft. high, and quite hardy; about London it is only half-hardy.

*Polygonum frutescens*, as high as *Atraphaxis*, and beautifully covered with cream-coloured flowers.

*Syringa speciosa* is the *Syringa rothomagensis* of *Arb. Brit.*

*Fraxinus floribunda* *Wal.* is *O'rnus floribunda* of *Arb. Brit.*

*F. O'rnus viridis* *Michx.* is *F. americana viridis* *Arb. Brit.*

*F. rotundifolia* is *O'rnus rotundifolia* *Arb. Brit.*

*F. monophylla* is *F. excelsior heterophylla* *Arb. Brit.*

*F. atrovirens* is *F. excelsior atrovirens* *Arb. Brit.*

*Vitex arborea* *Rox.* is a vigorous-growing plant, with broad leaflets, dentate, and of a much paler green than those of *V. A'gnus castus* or *V. incisa*.

*V. incisa* *Lam.* has the leaflets long, narrow, and deeply cut; it is here 5 ft. high, and beautifully in flower.

*V. A'gnus castus* is 16 ft. high, flowering profusely, and very beautiful.

*V. A'gnus castus* var. *latifolius* is 4 ft. high.

*Callicarpa americana* *L.*, a native of Virginia, nearly hardy.

*Salvia Hablitziana* *Jac.*

*S. scabriuscula* *Lam.*, 2 ft. high.

*Sideritis cretica* *L.*, 4 ft. high.

*Phlomis fruticosa* and *P. f. angustifolia*, 4 ft. high.

*Solanum glaucophyllum*, 4 ft., hardy.

*Lycium afrum* kept in pots, and taken in every winter.

*L. boerhaaviczefolium* is the *Crabowskia boerhaaviczefolia* of *Arb. Brit.*

*L. europæum*, leaves long and green; *L. ruthenicum*, leaves succulent, resembling those of *L. afrum*; *L. barbarum*, 10 ft. high, the species common in British gardens; *L. chinense*, leaves larger than those of any other species; *L. chilense*, leaves narrow, with short petioles.

*Sideroxylon lycioides* *L.*, leaves twice as long as those of *S. ténax* *L.*

*Diospyros virginiana*, 30 ft. high; *D. calycina*, *D. angustifolia*, *D. pubescens*, and *D. lucida*, are all obvious seminal varieties of *D. virginiana*.

*Halèsia diptera*, 4 ft. high.

*Artemisia procera* Willd., 5 ft. high; *A. valentina*, a more vigorous-growing plant than *A. Abrótanum*, and equally hardy.

*Córnus sibirica* is *Córnus álba sibirica* *Arb. Brit.*

*Æ'sculus ohioénsis* Michx. had no fruit; but we believe it to be the true species rather than the plant in the Hort. Soc. Garden, from the close resemblance of its foliage to that shown in Michaux's figure, and also because Michaux himself assured us that it was correctly named.

*Æ. hùmilis* is *Pávia fláva* *Arb. Brit.*

*Acer Lobèlii*, an exceedingly handsome specimen, 20 ft. high, is the *A. platanòides* *Lobèlii* *Arb. Brit.*

*A. disséctum* *Hort.* is *A. platanòides disséctum*, a very remarkable and apparently free-growing variety.

*A. coccíneum* is *A. rùbrum* var. *Arb. Brit.*

*A. lobàtum* *Bosc.* a very distinct variety, or rather hybrid, with invariably three pointed lobes which induces us to refer it to *A. créticum*; leaves not velvety beneath.

*A. neapolitànum*, a native of the South of Italy and Hungary, &c., is *A. obtusàtum* *Arb. Brit.* Leaves velvety beneath.

*A. híbridum* *Bosc.* a vigorous-growing plant, apparently between *A. obtusàtum* and *A. Pseùdo-Plátanus*. Leaves very slightly velvety beneath.

*A. Ópalus*, *A. opulifòlium*, *A. rotundifòlium*, are all varieties of *A. obtusàtum*. We have no doubt of this, having been convinced of it after examining the plants under the care of M. Camuset, and having heard his experience on the subject of these acers. In some of these varieties the leaves are scarcely at all velvety beneath.

*A. opulifòlium*. Leaves small and five-lobed.

*A. moneppulànum* is *A. créticum* var. *coriàceum* *Arb. Brit.*

*Tília platyphýlla* *Vent.* is *T. europæa grandiflora* *Arb. Brit.*

*T. pubéscens* *Vent.* is *T. americana pubéscens* *Arb. Brit.*

*T. argénteá* *H. P.* is *T. europæa álba* *Arb. Brit.*, a native of Hungary.

*T. mississippiénsis* *H. P.* is *T. americana* var. *Arb. Brit.*

*T. heterophýlla* *Vent.* is *T. americana* var. *Arb. Brit.*

*Támarix índica* *Willd.* is *T. gállica* *Arb. Brit.*

*Ribes*. The currants, gooseberries, and yellow and red blossomed sorts, are mixed instead of being arranged in sections. They are much in want of revisal.

*Nitrària Schòberi*, 5 ft. high, and very handsome.

*Nesæa salicifolia* *H. B. et Kunth*, the *Heimia salicifolia* *Link & Otto* and *Arb. Brit.*, is 3 ft. high, and stands the winter, as does *N. myrtifolia*.

*Málus sempervirens* *Desf.* is *Málus coronària sempervirens* *Arb. Brit.*

*Pýrus elæagnifolia* *Pal.* is *Pýrus communis* var. *elæagnifolia* *Arb. Brit.*

*P. índica* *Wal.* is *P. variolòsa* *Arb. Brit.*

*Cratægus latifolia* is *Pýrus Aria latifolia* *Arb. Brit.*

*C. flabellàta* *Bosc.* is *C. coccínea* var. *máxima* *Arb. Brit.*

*C. sorbifolia* *H. P.* is *Pýrus spùria* *Arb. Brit.*

*C. gláuca* *Wal.* is *Stranvæ'sia glaucéscens* *Arb. Brit.*

*C. Chamæméspilus* *Jac.* is *Pýrus Chamæméspilus* *Lindl.* and *Arb. Brit.*

*C. pyrifolia* is *Pýrus arbutifolia* *Arb. Brit.*

*C. spicàta* *Lam.* is *Amelánchier ovàlis* *Arb. Brit.*

*C. corymbòsa* *H. P.* is *Pýrus Aria crética* *Lindl.* and *Arb. Brit.*

*C. arbutifolia* *Lam.* is *Pýrus grandifolia* *Lindl.* and *Arb. Brit.*

*Méspilus constantinopolitàna* *Godefroy* is *Cratægus heterophýlla* *Flugge* and *Arb. Brit.*

*M. Azaròlus* is *C. Azaròlus* *Arb. Brit.*

*M. latifolia* *Poir.* is *C. pyrifolia* *Ait.* and *Arb. Brit.*

*M. spathulàta* is *Cratægus spathulàta* *Elliot* and *Arb. Brit.*

*M. odoràta* is *Cratægus orientàlis* *Bosc.* and *Arb. Brit.*

*M. tomentòsa* *Poir.* is *C. parvifolia* *Ait.* and *Arb. Brit.*

- M. stipulacea* is *Crataegus stipulacea* *Arb. Brit.*  
*M. tanacetifolia* is *C. tanacetifolia* *Arb. Brit.*  
*M. corallina* *H. P.* is *C. cordata* *Arb. Brit.*  
*M. coccinea* is *C. coccinea* *Arb. Brit.*  
*M. pyrifolia* *H. P.* is *C. punctata* *Arb. Brit.*  
*M. prunifolia* is *C. crúsgalli prunifolia* *Arb. Brit.*  
*M. Celsiana* is *C. tanacetifolia* *Leeana* *Arb. Brit.* When we gave the plant this name, we believed, as we were informed, that it was a seedling raised by Mr. Lee: we shall restore its true name in the second edition of *Arb. Brit.* and in a supplement. In the meantime we have done this in the catalogue of the Derby Arboretum.  
*M. fissa* *Poir.* is *C. Aronia* *Bosc* and *Arb. Brit.*  
*M. flabellata* *Bosc* is *C. coccinea* var. *máxima* *Arb. Brit.*  
*M. caroliniana* *Poir.* is *C. flava*.  
*M. lobata* *Bosc* is *M. Smíthii* *Arb. Brit.*  
*M. lúcida* is *Crataegus Crús-gálli lúcida* *Arb. Brit.*  
*M. affinis* is *Cotoneáster affinis* *Arb. Brit.*  
*M. racemiflora* is *Cotoneáster vulgáris laxiflora* *Arb. Brit.*  
*M. eriocarpa* *Dec.* is *Cotoneáster vulgáris* var. *tomentosa* *Arb. Brit.*  
*M. laxifolia* is *Cotoneáster rotundifolia* *Wal.* and *Arb. Brit.*  
*M. laxiflora* *Jacq.* is *Cotoneáster vulgáris laxiflora* *Arb. Brit.*  
*M. Oliveriana* *Dum.* is apparently a variety of the common hawthorn; but as the plant was not in a healthy state, it may, as Dumont conjectures, be a variety of *Crataegus tanacetifolia*.  
*Crataegus frígida* is *Cotoneáster frígida* *Arb. Brit.*  
*M. purpurea* and *M. Pyracantha* are *Crataegi*.  
*Prúnus* *H. P.* is in general *Cérasus* *Arb. Brit.*  
*P. græca* *H. P.* is *Cérasus Mahaleb* var. *Arb. Brit.*  
*P. incana* is *Amýgdalus incana* *Arb. Brit.*  
*Amýgdalus geórgica* is *A. nana* var. *Arb. Brit.*  
*Duvaúa depéndens* is as hardy as about London.  
*Ptélea trifoliata*, 25 ft. high, a very fine specimen.  
*Júglans fraxinifolia* is *Pterocarya caucásica* *Arb. Brit.*  
*Euónymus latifolius*, a very handsome specimen, 12 ft. high.  
*Hartógia capénsis* *H. P.* is *Cérasus Laurocérusus angustifolia* *Arb. Brit.*  
*Flex Cassine*, a vigorous plant, quite hardy.  
*Paliurus aculeatus* *Lam.* is *Paliurus australis* *Arb. Brit.*  
*Ceanóthus azureus* is in flower as a bush, in the open garden, and requires no protection during winter.  
*Morus álba* var. *italica* has the soft wood of the current year's shoots of a dark red; but there is no exterior indication of this, and it can only be found by removing a portion of the bark.  
*M. constantinopolitana* is a variety of *M. álba*.  
*Ulmus campéstris latifolia* is *U. montana* *Arb. Brit.*  
*U. crispa* *H. P.* is *U. montana crispa* *Arb. Brit.*  
*U. pedunculata* *Frey.* is marked a native of France, and may possibly be the *U. effusa* of the Hort. Soc. Garden and the *Arb. Brit.*; but whether it is a native or not is uncertain.  
*U. exoniensis* is the *U. montana fastigiata* *Arb. Brit.*  
*U. americana* is without doubt the *effusa* *Arb. Brit.*, and quite different from the *U. pedunculata* mentioned above. The leaves of this species, both in England and France, have a tinge of red on the veins. From specimens received from Dr. Torrey, we believe this plant to be correctly named.  
*U. pyramidata* is *U. campéstris pyramidata*, a very distinct variety, with a conical habit.  
*Céltis mississippiensis* *Bosc*, very distinct.  
*Sáliz acuminata* is *S. álba* *Arb. Brit.*  
*Pópulus tremula* is *P. álba* *Arb. Brit.*

- P. nîvea* Fischer is *P. álba* var. *Arb. Brit.*  
*P. græ'ca* H. P. is *P. tremulòides* *Arb. Brit.*  
*P. Hudsoniàna* Mich. strongly resembles *P. nîgra* *Arb. Brit.*, and may possibly be only a variety of it, in which opinion Michaux concurs.  
*P. virginiana*, the Peuplier Suisse, is the *P. monilîfera* *Arb. Brit.*; the male plant is distinguished from the female by the petioles of the leaves being red.  
*P. canadénsis* is *P. monilîfera* var. *Arb. Brit.*  
*P. ontariénsis* Desf. is *P. cándicans* *Arb. Brit.*  
*P. cándicans* H. P. is *P. balsamîfera* *Arb. Brit.*  
*P. suavèolens* Fischer is *P. balsamîfera suavèolens* *Arb. Brit.*  
*Bétula pòntica* H. P. is *B. papyràcea* H. K., and *Arb. Brit.*  
*B. urticæfòlia* is *B. álba urticæfòlia* *Arb. Brit.*  
*B. dalecárlica* is *B. álba dalecárlica* *Arb. Brit.*  
*Álnus communis* H. P. is *A. glutinòsa* Gært. and *Arb. Brit.*  
*Quércus crinîta* Bosc is *Q. Cérris* *Arb. Brit.*  
*Q. prásina* Bosc is *Q. sessiliflòra* *Arb. Brit.*, with leaves glaucous, small, and on long petioles.  
*Q. Táuzin* Bosc is *Q. Prînos* *Arb. Brit.*  
*Q. Túrneri*, a specimen 12 ft. high.  
*Q. Ròbur* Willd. is *Q. pedunculàta* *Arb. Brit.*  
*Plátanus orientális* is *P. occidentális* *Arb. Brit.*  
*Pînus Banksiàna* is *P. sylvéstris* *Arb. Brit.*  
*P. mìtis* Mich. is *P. inops* *Arb. Brit.*  
*P. inops* Mich. is *P. serótina* *Arb. Brit.*  
*P. excélsa* is *P. longifòlia* *Arb. Brit.*

It will be observed that among the foregoing names affixed to the plants in the Paris garden, the greater number are legitimate synonymes, though there are some, as for example, the six last, which are names erroneously applied.

M. Camuset is the *chef* of that department of the Jardin des Plantes which may be called the nursery, as his duty is to propagate all the more hardy species of trees and shrubs by seeds or otherwise, for distribution among the provincial gardens, and for making exchanges with foreigners. Having been nearly fifty years in the garden, he has had great experience in raising trees and shrubs from seed, and knows the origin and history of many alleged species and varieties. He has raised a number of seedling robinias, some of which are in Mr. Rivers's catalogue, and chiefly from the seeds of the original tree brought to Europe and planted by Vespasian Robin in this garden in 1635.

The following memorandums were chiefly made on the spot:—

- Clématis cylîndrica* Camüzzi, raised by M. Camuset in 1838, differs from the species, in having bell-shaped purple flowers, whereas in the species they are of a somewhat bluish purple.  
*Mahònia Aquifòlium* is as hardy in the climate of Paris as the common box; and is therefore of great value, there being so few evergreens which will stand through the winter in that climate.  
*Ácer sacchárinum* var. *nigrum* differs from the species in the leaves not being in the slightest degree velvety beneath; it is exceedingly difficult to propagate, and unites with difficulty when inarched.  
*A. rubrum* grafted on *A. Pseudo-Plátanus* invariably forms a bulging protuberance immediately above the graft. Seeds from an old plant of *A. monspessulànum* have produced *A. créticum*, *A. coriáceum*, *A. heterophýllum*, and other varieties. M. Camuset pointed out plants containing leaves with long petioles and five lobes, and other leaves with short petioles and three lobes, on the same branch, some of which we brought with us, as a proof that the Montpellier and Cretan maples are essentially the same species. He also showed us on the same seedling, from the tree mentioned, coriaceous leaves  $1\frac{1}{2}$  in. broad, and others not half an inch broad. From the same seedlings, there were some plants with scarcely

- any of the leaves lobed. From a patch of seedlings of about twenty plants, being all that had come up from fifty seeds of *Acer Lobèlii* sown, two plants were the genuine species, *A. platanoides*, without the bark being in the slightest degree striated. Seeds of *A. rubrum* have produced plants of *A. sanguineum*, which has the leaves very glaucous beneath; of *A. coccineum*, which nearly resembles *A. sanguineum*; and of *A. eriocarpon*. *A. obtusatum* occasionally produces *A. hybridum*; and *A. opulifolium* produces *A. O'palus*, *A. obtusatum*, and other similar varieties, to none of which names have been given. *A. Pseudo-Platanus* has given *A. trilobatum*. *A. lobatum* is a very distinct variety, but M. Camuset does not know its origin. *A. coriaceum* was found in 1830, in a bed of seedlings of *A. monspessulanum*, and from that plant all others bearing this name sent from the Paris garden have been raised by grafting.
- Æsculus rubicunda*, planted among other trees taller than itself twenty-five years ago, has a trunk not 4 in. in diameter; but another plant of the same species, planted in a more favourable situation on the same day, has a trunk above 18 in. in diameter, and a magnificent head.
- Vitis vulpina*, the fox grape, has the male and female on different plants, and the female has invariably the larger leaves, and is the stronger plant.
- Ailantus glandulosa* was planted near the museum in 1793, by citizen Thouin, then director general of the garden, and professor of culture, who named it the tree of liberty, which name it still retains among French gardeners.
- Euonymus nanus* *Bieb.*, grafted standard high on the common euonymus, forms a singularly handsome plant, and is never touched by insects like the other species.
- Ceanothus americanus* *L.*, raised from seed, exhibits various varieties, with white and blue flowers.
- Virgilia lutea* *Mich.* The original plant brought over by Michaux is 30 ft. high, with a head 34 ft. in diameter, and is now covered with legumes, forming a singularly handsome object.
- Cytisus alpinus purpurascens*, M. Camuset believes to be a hybrid seedling, which had been bought by M. Adam, among a number of other seedlings; the custom of the nurserymen at Vitry being to purchase seedlings in quantities, and grow them a year or two for sale. This, M. Camuset thinks, is a much more rational mode of accounting for the origin of this hybrid than that of supposing that a shoot from the margin of a dormant eye had produced it; and, in this opinion, in the absence of all positive evidence, we concur. Of course this does not account for the very singular anomaly of *C. L. purpurascens* separating, as it were, into the two original parents. Mr. Herbert's hypothesis will be found in our preceding volume, p. 289. and p. 381., and M. Poiteau's in the current volume, p. 58.
- Robinia Pseud-Acacia* has produced, with M. Camuset and other cultivators, several varieties which are not yet in cultivation in the trade; in short every bed of seedlings shows varieties more or less distinct. M. Camuset has named *R. P. longipetiolata*, *R. P. longispina*, *R. P. macrophylla*, and *R. P. Norioniana*, with yellow foliage, after a cultivator of that name.
- R. viscosa*, with M. Vilmorin, has produced plants not in the slightest degree different from *R. Pseud-Acacia*.
- Gleditschia triacanthos* *L.*, from seed, has produced *G. inermis*, *G. macracantha*, and *G. ferox*. *G. caspica* and *G. sinensis* seem distinct; but this genus varies so very much that M. Camuset is uncertain what are species and what are varieties.
- Amygdalus nana* has produced *A. georgica* *Dec.* and *A. campestris* *Ser.*
- A. incana* produces abundance of small red fruit.
- A. Persica* flore pleno, the common double-flowered peach, produces abundance of fruit, the nuts of which invariably produce plants bearing double flowers; a fact which seems to show that varieties of peaches come tolerably true from seed. Hence, in some situations where the soil is

very shallow and dry below, and economy a main object, it might be advisable to renew the peach trees on a wall, by planting the nuts where the plants are finally to remain.

The *Pêche d'Espagne*, or wild peach, produces double flowers, which invariably appear fifteen days later than those of the common double-flowered peach. This seems a very desirable variety with a view to prolonging the season of double peach blossom, and we are not aware of its being in British gardens. Were French postage as cheap as that of Britain, cuttings might easily be sent by letter in the budding season.

*Armeniaca nepalensis* is nothing more than the common apricot.

*Cerasus borealis* and *C. persicifolia* are the same.

*C. hyemalis* is the same as *C. nigra*.

*C. græca* is a variety of *C. Mahaleb*.

*Prunus reclinata* is a variety of the common plum, and is the same as *P. nigra*.

*P. Pâdus* has produced a variety with spotted leaves, like those of *aucuba*.

*Crataegus Crus-galli salicifolia* has produced seedlings with broad spatulate leaves, deeply notched.

*Ribes* has varied exceedingly from seed. *R. cereum* has produced deep green leaves, three or four times larger than those of the species. *R. palmatum*, *R. macrocarpum*, *R. aureum*, *R. luteum*, and *R. tenuiflorum* are all produced from the same seed.

*Symphoricarpus racemosus* has produced a variety which retains the fruit all the winter, and is very distinct. It ought to be procured by British nurserymen.

*Diospyros virginiana* has produced several varieties; and M. Camuset thinks all the American kinds may be reduced to one species.

*Fraxinus americana* produces numerous varieties from seed.

*Morus alba italica* has, as already mentioned, the soft wood, or alburnum, of the young shoots red. Whether this is peculiar to *M. alba italica*, or constitutes a subvariety or a variation of the Italian mulberry, M. Camuset is uncertain.

*Maclura aurantiaca* bears fruit every year; but, the male plant not having yet produced flowers, the fruit does not ripen.

*Ulmus campestris tortuosa* is the only elm which grows freely by cuttings, and is always so propagated in France. The tree is much prized in France for the timber; which, having the grain or fibres very much twisted, will not split, and is therefore much used for the naves of wheels.

*U. campestris latifolia*, the *U. montana* of Bauh., has, as before stated, been found with the alburnum of the young shoots red, like that of *Morus alba italica*, and this variation is continued by grafting.

*Celtis Tournefortii* and *C. orientalis* are considered the same.

*Populus græca*, *grandidentata*, *trépida*, and *trémula* are varieties of one and the same species.

*P. monilifera*, *canadensis*, *betulifolia*, *undulata*, and probably *P. nigra*, are, perhaps, essentially the same species.

*P. vistulensis*, which produces finely veined wood, much used for small cabinet-work in Berlin, is *P. nigra*.

*Pinus Laricio* is 75 ft. high.

We omit giving the dimensions of a number of large specimens of trees in the Jardin des Plantes, as they were taken by M. Camuset in 1837, and forwarded to us by Professor Mirbel, and will be found in their respective places in the *Arboretum*.

*Fontainebleau*. — July 29. to 31. MM. Vilmorin and Poiteau accompanied us to Fontainebleau by the diligence, and we returned by the Seine. Between Paris and Ris the soil is deep,  
1841. — VIII. 3d Ser. D D

rich, and covered with heavy crops of wheat, potatoes, clover, and beans. Beyond Ris we pass through vineyards containing some standard peaches, which, in the time of Henry IV., supplied the Paris market, till, in the time of Louis XIV., peaches began to be grown against walls at Montreuil. Enter the Forest of Fontainebleau, and pass some fine old oaks and beeches; the oaks all *Quercus sessiliflora*. The blanks in the forest are carefully filled up with *Pinus sylvestris*, poplars, and various other trees, according to the nature of the soil and the character of the surface. The ground in various places previously prepared; and after planting it is kept tolerably clear of weeds. Arrived at the town, we immediately called on M. Souchet, the royal gardener, a most intelligent and obliging man, who showed us every thing under his care. The English garden here, being in a low situation, with abundance of water, the turf was of a deeper green than in most of the places about Paris. The trees have grown rapidly, and attained a large size; but they were much crowded. A great many fine specimens of *Pópulus monilífera*, both male and female; the latter produce abundance of seeds, from which young plants rise in great quantities. A variety of horsechestnut, with a fastigiate head, crowded with straight ascending shoots. The reserve garden here is richly stocked with plants, both in pots for supplying the palace in the autumn and winter, and in the open ground for the borders of the ancient garden in front of the palace. *Lechenaúltia formósa* is grown in great quantities, trained to a single stem, and flowers the greater part of the year. *Phýlica ericóides*, so treated, is in flower throughout the winter. We never saw plants better grown than they are in this reserve garden, which is under the care of M. Souchet's son; and the merit is the greater, as the pits and frames are of the slightest and most temporary construction.

The orange trees here are in a better condition than any which we saw in France. The foliage is of a deep green, the shoots vigorous, and the heads large and handsome. The soil they are grown in is loam, enriched with rotten dung or leaf mould; and they are placed in the summer season in a situation shaded by lofty trees, which, we apprehend, is the cause of the deep green of the leaves. Their vigorous growth M. Souchet attributes to their being properly supplied with water in the growing season, and not having too much when they are in a dormant state. In many cases, he says, orange trees are watered abundantly, and yet the main body of the soil is never penetrated by it, which he takes care shall always be the case. The trees are kept through the winter in a stable, with very little light, and no fire-heat.

The geometric garden is a square, surrounded by a broad terrace, raised about 5 ft. and containing a double arcade of



lime trees, from which the garden is seen to very great advantage. The interior of the square is laid out in four rectangular figures, with a large square basin and fountain in the centre. The rectangular figures have borders about 5 ft. broad, with gravel walks about 3 ft. broad, within. The borders are planted with perennial and annual herbaceous plants, in large, handsome, distinct bushy plants; the greater part of which being in full flower when we saw them, the effect was splendid. Among the flowers which were most showy were, the common double pot-marigold, double feverfew, *Petunia phœnicea* and *nyctaginiflora*, phloxes, *Antirrhinum majus*, *Îbèris umbellata alba* and *violacea*; and we noticed besides, *Hesperis matronalis*, *Valeriana rubra*, *Aconitum variegatum*, *Hemerocallis flava*, *Callistema sinense*, *Alýssum saxatile*, *Veronica virginiana*, *Campánula Mèdium*, *Pæonia officinalis*, *Dianthus barbatus*, and a few others. The shrubs were few, chiefly *Hibiscus syriacus*, pruned into regular shapes, and placed at distances of 20 or 30 feet apart. Nothing which we saw in France, in the way of flowers, surpassed the beauty of these borders. The interior of the compartments is sown with *Festuca ovina*, without any mixture whatever of other grasses or plants; and, notwithstanding that the soil is a very dry sand, and is never watered, the closeness and compactness of the turf were, to us, truly astonishing. It was only deficient in colour, which was brown rather than green. M. Vilmorin informed us that he had sent specimens to London some years ago, which were compared with the specimens in the herbarium of Linnæus, and found to be the true *F. ovina*.

Among the lime trees which composed the double arcade on the terrace, there is one which has the trunk entirely deprived of its bark for the space of about 2 ft., and which has been known to be so for thirty years. It still continues to live, though not so vigorous as the others. *Fig. 51.* is a sketch of it made on the spot by M. Poiteau, who, with the Inspector of the Forest, M. Marrier de Bois d'Hyver, accounts for its living by supposing the sap to ascend through the interior of the trunk; the only chance, indeed, by which it could ascend.

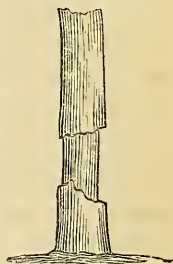

*Fig. 51. Disbarked Lime Tree.*

There was formerly a large royal kitchen-garden here; but that is now much reduced. There remains, however, a wall (la treille royale) covered with vines, to which an addition has lately been made, so that the total length is now 702 toises, or upwards of 4200 ft. Some part of the wall is 20 ft. high, and the remainder about 12 ft. The vines are chiefly trained in the manner of those at Thomery, described in one of our earlier volumes. Nothing could exceed the health of the plants, or the

perfect manner in which they were trained and managed under the direction of the kitchen-gardener.

The border in front was about 12 ft. wide, not cropped, but protected from being trod on by a low trellis, also covered with vines. One use of this trellis, we were informed, was to afford a few grapes to the passers by, that they might not be tempted to take any from the wall. The wall is of stone, rough-plastered, and covered with a wooden trellis, to which the vines are tied with willow twigs. The coping of the wall is of flat tiles, and projects about 1 ft. to throw off the rain, which would otherwise take off the bloom from the fruit, and render it unsightly at table. For the same reason, the ground at the base of the wall is covered with vine leaves and prunings to the breadth of about 18 in., to prevent the rain which drops from the coping from splashing the grapes on the lower lines of the trellis, the bunches of which reach within a few inches of the soil. The kind of grape planted is chiefly the Chasselas; but there are also some Muscats, and other kinds, but none, we believe, of either the Muscat of Alexandria or the Black Hamburg. A peculiar kind of mousetrap, of very small size, is inserted at intervals between the trellis and the wall. The ver blanc is here, as every where else, troublesome in the border.

We were conducted through the most interesting parts of the Forest of Fontainebleau by the Inspector-General, M. Marrier de Bois d'Hyver, already mentioned. This gentleman possesses a scientific knowledge of trees and shrubs, and of every part of forest management; and he is, besides, enthusiastically devoted to the subject. Previously to proceeding to the forest, he showed us a map of the whole, including the palace and gardens, as they existed before the time of Le Nôtre, by which it appears that the interior of the compartments of the flower-garden, which are now covered with *Festuca ovina*, were at that time laid out in parterres of embroidery. Le Nôtre had simplified the design; judging, perhaps, that the parterres of embroidery were too distant from the eye to produce their proper effect. M. Bois d'Hyver showed us his specimens of indigenous woods, and also several pieces of furniture made of the common juniper, from trees which afforded boards from 6 in. to 9 in. in width. We also tasted at his table a very excellent fragrant spirit, made from the berries of *Cerasus Padus* and *C. Mahaleb*, the flavour of which was somewhat like that of kirschwasser. In proceeding through the forest, we saw numerous trees of *Pinus Laricio* grafted on *P. sylvestris*, numbers of which are 50 ft. high, bearing cones. *P. Stròbus*, *P. pumilio*, and *P. Cémbra* are also grafted on *P. sylvestris*, and doing well. There are in the forest about 3000 hectares (about 7000 acres) covered with pines, and about 20 hectares on which the *P. Laricio* is

grafted. The remainder of the forest is covered with indigenous oaks (*Q. sessiliflora*), beeches, birch, trembling poplar, and in some places with shrubs or low trees, such as *Cerasus Padus*, *Rhamnus* (different species), *Cornus*, *Juniperus*, *Ulex*, &c. The forest is intersected with avenues and public roads in all directions, some of them the great routes of the country, and others made expressly for the convenience of managing the forest. All the latter are open to the public, and form agreeable rides or walks; which, according to their direction, the season of the year, or the hour of the day, are either open and exposed to the sun, open and in the shade, or arched over with trees. All these roads and alleys, as far as we saw them, were in excellent order; the sand being hoed and raked, and the grass of the green alleys mown. Most of the broad alleys have small side avenues, like the side aisles of a church, separated from the main alley by rows of trees, which are different in different alleys, according to the nature of the soil. There are some handsome avenues of *Platanus occidentalis*, others of *Ailantus*, of *Robinia*, of *Gleditschia*, of poplars of various kinds, of birch, of alder, and even of Scotch pine. The management of the forest, as described to us by M. Bois d'Hyver, appeared admirable. The most rigid economy is preserved in every thing, and every thing is turned to profit in some way or other. For example: there are certain parts of the forest covered with heath, without trees, and these are gradually being sown with seeds of the Scotch pine or *P. Laricio*. The seeds are first sown on the heath, and then the latter is sold to the inhabitants to be pulled up as fuel. The act of pulling up is found to be a sufficient stirring of the soil, and covering for the seeds; so that the sowing is the entire expense. The seed is procured from cones gathered in the forest at so much per bushel; and the cones, after being deprived of the seeds, are sent to Paris, and sold as a fuel of luxury, for more than the cost of gathering them and taking out the seeds.

All the labour performed in the forest is let by the job; and the reason why the alleys of every kind are in such excellent order is, that the keeping of them is let out to different persons, who vie with one another in keeping what is under their charge in high order. The grafting of the pines, which was commenced by M. de Larminat, the predecessor of M. Bois d'Hyver, as noticed in the *Bon Jardinier* for 1826, in the *Gardener's Magazine*, vol. ii. p. 63., and the *Arboretum Britannicum*, vol. vi. p. 2130., is carried on to the extent of some thousands annually; not by gardeners or regular foresters, but merely by the guards of the forest, whose business it is throughout the year to perambulate the forest to detect trespassers. Hence this grafting costs

nothing, as these men must be paid at any rate for their services as guards of the forest.

*Thomery.*—This village is situated on the banks of the Seine, and covers the lower part of a slope, having a north aspect. It is, nevertheless, well sheltered from the north winds, by a continuous ridge on the opposite bank of the Seine, which directs the north winds completely over the village. No south wind can touch it, because that is thrown off from the upper part of the bank of which the village forms the lower part; and it is protected from the east and west winds by the winding of the Seine and its accompanying banks. These circumstances have the effect of placing Thomery in a basin, sheltered on every side; but which, nevertheless, does not retain the cold air which descends from the high grounds, because that is carried off by the current of the river. Hence the suitability of the situation for the vine culture on walls. The appearance of the village, on first approaching it, is that of a succession of tiled copings to walls apparently at a very short distance from one another, with here and there a small dwelling-house intervening, and in the distance, by the river side, a long row of houses, which constitutes the village. The extent of ground covered by the walls has been more than doubled within the last ten years. The manner in which the vines are planted, trained, and managed has been so clearly described and illustrated by figures in Vol. V. p. 286. to p. 292., that we consider it unnecessary to enter into details. The practice recommended by Mr. Hoare, in his *Treatise on the Culture of the Vine*, comes the nearest to that of Thomery of any we know, and was probably suggested by it. On those aspects not suitable for the vine, the apricot is planted; and on those not suitable for the apricot, the crassane pear is trained. The grapes, which are almost all of the light-coloured varieties of Chasselas, are fit to eat about the middle of August, but seldom gathered and sent to market till the end of the month. Nevertheless, on the 29th of July we found several bunches sufficiently ripe to be very good to eat; but the cause of this maturity was, that the seeds had not been fecundated, and hence the berries were without stones, and as small as those of the Corinth grape. At the same time, there were exposed for sale in Fontainebleau, as well as in Paris, grapes of what is called the Madeleine, or, in England, the Black July, which were tolerably ripe, and full grown; but they were deficient in flavour, and such as a London fruiterer would say “no gentleman would eat.” In the original account published of the fruit walls of Thomery in Lelieur’s *Pomone Française*, the walls are said to be of mud, washed over with mortar, with copings of boards or straw: but they have, within the last few years, been all rebuilt of stone; in most cases dry, and in some cases

laid in mortar of loam, and plastered with lime, with copings of flat tiles, forming a roof projecting about 9 in. on each side of the wall, and, consequently, balanced and held in its place by being raised in the centre, so as to form a miniature roof. The freestone with which these walls are built forms the substratum of all the gardens, though it is, in many cases, too deep to be conveniently quarried. We went through a number of the gardens in company with M. Poiteau, M. Souchet, and one of the principal cultivators, and found, as usual, the ground remarkably free from weeds, and every where loose, in consequence of being stirred 8 or 9 inches deep, and somewhat rough on the surface; experience having taught these industrious and observing men that the ground being in this state is a better non-conductor of heat and moisture than if it were hard and smooth; and, consequently, when the soil is warmed by the radiation of the sun to the depth of 1 or 2 feet, which it is even in spring, the heat does not escape so rapidly as it otherwise would do; while the rain, not lying on the surface, cannot evaporate so quickly.

From Thomery we returned to Paris by the steam-boat on the Seine, passing several villas on its banks, and one or two large mansions. The most tasteful small villa was a cottage on the top of a steep bank, with its garden, in the form of a parallelogram, reaching to the towing-path. The ascent to the house was by a regular zigzag path to a rustic arch in a terrace wall; which, doubtless, led to the offices, while the terrace was on a level with the living-rooms. The most English-looking places which we saw were, the Park of Fromont, M. le Chevalier Soulange-Bodin; and Petit Bourg, the residence of the Spanish banker, M. Aguado. This wealthy and liberal gentleman has built a suspension bridge across the Seine, and sold it to the department at a price merely nominal. We passed several suspension bridges and several stone bridges, some arches of which had been blown up during the invasion of 1814, and were not yet rebuilt. Such are the miseries of war; though these are nothing when compared with dragging away children from their parents, and forcing them to the cannon's mouth, as must necessarily have been the case in France in many thousand instances.

*The Palace of Fontainebleau*, and the villa near it which formerly belonged to Madame de Pompadour, occupied us the greater part of a day. The palace is extremely interesting, in an architectural point of view, from the different styles which it exhibits, and more particularly those of Francis I. and Louis XIV. The first is characterised exteriorly by immense windows in the upper part of the building, where, in most manners of architecture, the windows are generally smallest, about a third of the height of these large windows being in the upper part of the

walls, and the remaining two thirds in the roof; and another characteristic is straight jambs and lintels to the chimneys: while the style of Louis XIV. has the largest windows on the second story, or what in England is called the first floor, with windows entirely in the roof; and, interiorly, curved lintels and jambs to the chimneys. Other descriptive details might be given of the two styles, but these we think are specific features. To describe the palace in detail would occupy a volume. We shall only notice the Chapel of St. Saturnin, built by Louis VII. in 1169, which is the oldest part of the building; the Church of the Trinity, and the Pavilion of Louis IX. The great body of the palace was built by Francis I. and Louis XIV. Henri IV., who inhabited this palace with the fair Gabrielle d'Estrées, built la Cour des Cuisines and part of that of des Princes. Louis XIII., the son and successor of this king, was born at Fontainebleau in 1601; and was baptised under an open cupola raised over an archway which leads from one large court to another, in order that the baptism might be seen by some thousands of persons, who were assembled in each court. This cupola is called the Cupola of the Dungeon; a dungeon, it is supposed, having originally existed beneath it, but at present there is no indication of anything of the kind.

*The Villa of Madame de Pompadour* is at present in possession of M. le Baron de Hanequert; whose son-in-law, M. le Marquis Boiseplat, was so good as to show us the plan of the house and grounds as originally laid out. The situation of the villa is quite near the palace, but separated from the palace gardens by the public road. The piers of the private gate by which Louis XIV. went privately from the palace, across the public road, to the gates of Madame de Pompadour, still exist in the wall, the place of the gates being built up. Madame de Pompadour's villa must have been exceedingly convenient; and from the extent of stables, coach-houses, and other offices attached to it, she must have lived in good style. The house was entered through a large square court of honour, paved. To the right a wall separated this court from the offices; and to the left a similar wall, with a similar gate, separated it from a small flower-garden, containing an orangery, a fountain, and some ornamental buildings. On the garden front of the house, a long narrow parterre extended to a considerable distance; and on the right and left were bosquets, intersected by various straight walks, radiating from stars and patées-d'oye. Beyond was the kitchen-garden. The whole was surrounded by a high wall, which, however, had openings in two places to admit views along glades in the forest. These openings are protected exteriorly by deep pits, which are called *sautes-de-loup*, a term which is generally applied to the opening itself. These openings

only differ from our ha-ha, or sunk fence, in not having the outer side sloped. They are, therefore, much more effective as barriers, though extremely dangerous to men and cattle. Those of Madame de Pompadour were 30 ft. in length, 12 ft. wide, and 9 ft. in depth, the side walls being perpendicular, and without the slightest indication of protection; so that in a dark night any animal wandering near such a pit, and perhaps attracted by a light proceeding from the windows of the house, might very readily fall into it, and death, or at least broken limbs, would be the certain consequence. The soil being a dry sand on the peculiar sandstone of the district, we suppose no water ever stood in them.

The present proprietor has arranged the grounds in the modern manner, and some very good kinds of ornamental trees and shrubs are planted in them; but there is not obtained a tenth of the comfort and enjoyment which such a place is calculated to produce, partly, perhaps, from these not being desired. What particularly struck us was the wretched state of the trees on the walls, not a fourth part of the surface of the latter being covered with branches.

The town of Fontainebleau formerly contained some large palaces, the residences of the nobility, attendants of Louis XIV., but they have been razed to the ground, and the materials sold, since the first revolution; and the chimney-pieces of these palaces have long since been fixed in England. We were also informed by the Baron Hanequert, that some of the chimneys belonging to the royal palace were purchased many years ago when a part of the building was taken down, and that after remaining several years in a cellar, they ultimately found their way to this country.

From Paris we returned to Rouen by the Seine, and from Rouen by the same conveyance to Havre; passing the interesting Château de Landin, described in our Vol. for 1829, p. 644., and the still more interesting Château de Tankerville, which was purchased by the celebrated financier and gambler Law of Laureston. The château, and seven acres of ground round it, are, according to the guide-book, let for 350 francs a year. It would form a delightful summer residence to an inhabitant either of Paris or of London.

*Havre.*—We unfortunately had not time to visit the collection of the British consul, Gilbert Gordon, Esq., or that of M. Eyries, and some other collections known to us by reputation as being well worth examining. We had a delightful voyage to Southampton, where, after visiting Mr. Page's home nursery, which we found as usual, brimful of plants in the very highest order, we set off by the railway, and in three hours and a half were at Bayswater.

ART. II. *Further Observations on the Philosophy of Manures.*

By R. LYMBURN.

SINCE writing to you before, on the publications of Professors Daubeny and Johnson on the subject of manures, there has appeared a very able review of Dr. Liebig's work in the *Quarterly Journal of Agriculture*. The intimate knowledge displayed of chemical action, and the cautious manner of applying it to practice, I think, point out Dr. Madden as the author. The reviewer, after giving great credit to the transcendent abilities of Dr. Liebig, says that, nevertheless, his application of them to practice has given great disappointment; and that old theories must still be adhered to, till some more decided proofs of their fallacy are brought forward. Dr. Liebig's statement, that humic acid cannot yield the carbon necessary to plants, because of its insoluble properties, he combats by stating Dr. Liebig's opinion, that the ammonia so necessary to plants "passes through the soil;" and he finds himself, by experiment, that neither ammonia nor carbonate of ammonia can pass through soil without combining with humic acid. All the ammonia must have reached them, therefore, in combination with humic or some other acid; and he thinks, therefore, the greatest part of the carbon of plants is derived from the humate of ammonia. Wheat, he says, contains 1 per cent of lime and alkalies; which, combined with humic acid 10·9 grains, would yield 6·32 grains of carbon. It also contains 2·13 grains of nitrogen, which, as humate of ammonia, would yield 27·3 grains of carbon; in all, 33·62 per cent of carbon, while the wheat itself only contains 43 per cent. Dr. Liebig has forgot, he says, in his estimate of the quantity of soluble humic acid in soil, which he states at less than 100,000th part, that it is a substance constantly being produced, and constantly taken up, and not a permanent ingredient in the soil. In forty-two days, the time between the flowering and the ripening of the wheat, there will have been deposited in an acre of wheat 500 lb. of carbon, equal to  $877\frac{1}{2}$  lb. of humic acid, about  $\frac{1}{5241}$  part of the weight of the soil, which the soil could not have yielded at once, without the formation of humic acid were a continuous one. He thinks all the humic acid in the soil at one time will probably be consumed in ten days or a fortnight. That neither humic acid nor humate of lime has been found among the stalactitic formations of carbonate of lime in caverns, he accounts for by saying that the humus is extricated from the humate of ammonia in filtering through the soil, and deposited.

Where such eminent men are at variance, it would be difficult to decide. But, perhaps, it will not be of much consequence to the practical man, whether the humus in the soil gives off its carbon to the roots in the form of carbonic or humic acid. The



humic acid contains most carbon, but must, therefore, consume more organic matter in its formation; and carbonic acid being so much more largely soluble in water (rather more than its own bulk), would seem to point it out as the medium of conveying carbon to plants. Humic acid abounds in moss water, which is rather prejudicial to growth than otherwise; but it contains tannin, which is thought to act on the membrane of the spongiole of the roots by its astringent nature. I have seen plants exposed to the bottom heat of bark often spoiled; they get hard and stunted, the leaves of a reddish brown colour. The reviewer notices Dr. Liebig's admission, that carbonic acid forms the food of the young plant by the roots, and considers it contradictory of his former statement, that manure yielded no carbon to plants by the soil. As to the statement of Dr. Liebig, of soil becoming progressively richer in carbon every year, notwithstanding the quantities of carbon extracted from it, endeavouring thus to show its being chiefly derived from the atmosphere, the reviewer here enters into a calculation of the quantity of carbon deposited in the soil by thirty tons of farm-yard manure (which he estimates at  $15,281\frac{1}{4}$  lb.), the quantity per acre for a crop of turnips. He next calculates the quantity removed in four succeeding crops of turnips, barley, hay, and oats, which he estimates at  $9,543\frac{2}{3}$  lb. More than a half of this quantity, or  $5,737\frac{2}{3}$  lb., has, therefore, been deposited in excess, when the field was dunged for turnips. Dr. Liebig has stated that no more carbon is produced from manured than unmanured land; and has stated the quantity from woodland as  $2,166\frac{1}{2}$  lb. of carbon annually per acre. The reviewer, however, shows that an ordinary crop of turnips (30 tons) will yield  $2,889\frac{2}{3}$  lb., while an extra crop (45 tons) would yield  $4,334\frac{2}{3}$  lb. of carbon. It is further incorrect, he says, to consider forest land as unmanured, when so much is furnished to it by birds and the leaves. The dung annually of 100 sparrows he calculates at 36 lb., of a manure five times as strong as farm-yard manure; and the leaves of an acre at  $772\frac{1}{3}$  lb. of carbon. These all give reasons for the increase of carbon, independent of the atmosphere. The fact, also, of firs consuming less nitrogen than the cultivated plants, he says, accounts for the accumulation of carbon in woodlands. As all the carbon, he thinks, is given to the plant in combination with ammonia, he considers ammonia as the most important solvent for carbon; and, therefore, manures containing nitrogen as the most beneficial. If, however, carbonic acid itself is so largely soluble, I do not perceive the need of ammonia as a solvent.

On the subject of nitrogen, the reviewer cordially agrees with Dr. Liebig, in all his statements, as to the importance of this substance. He has verified the experiments, and found the

ammonia to have the offensive smell of perspiration, as stated. But he found only  $\frac{9\frac{2}{10}}{1000}$  of a grain in the pound of rain water, rather more than one twelfth; whereas Dr. Liebig made it one fourth of a grain. Perhaps some difference may arise from rain falling more frequently where the analysis of the reviewer was made. This would yield only  $71\frac{4}{5}$  lb. of ammonia to the acre. He found, also, he says, his analysis would give  $641\frac{2}{5}$  lb. of common salt: it must surely have been from rain collected near the sea. The reviewer states it as his opinion, that animals fed on substances destitute comparatively of nitrogen, as oil-cake, which contains little nitrogen and an excess of hydrogen, will produce fat, and not beef or muscle, the fibrin, albumen, and osmazome of which contain much nitrogen. Substances containing nitrogen will also yield most muscular tissue, he says, especially if steady and continued exertion be used. That substances yielding nitrogen should be productive of substances containing nitrogen is certainly fair inductive reasoning; yet, as I said before, I have seen persons fed on potatoes, containing little nitrogen, who were very muscular: they had, however, plenty of exercise in the open air. Some authors are of opinion that nitrogen is inhaled. From Dr. Liebig's statement of its being found, in an uncombined state, around the living organs, it appears also to act as a stimulant. The reviewer next notices Dr. Liebig's opinion, "that sulphate of lime is valuable as fixing the volatile salts of ammonia;" but says this is valueless, as the particles of soil are capable of retaining  $\frac{1}{4}$  per cent of ammonia, which would yield nitrogen for fifty years to the heaviest crops of wheat: there can be no need, he says, for fixing it. The sulphate of lime acts only, he says, as forming a constituent of the plant. Independently, he says, of the nitrogen contained in the soil, the 30 tons of manure will yield  $268\frac{4}{5}$  lb., or only  $1\frac{3}{5}$  lb. less than the whole four crops of turnips, barley, hay, and oats require.

On the subject of alkalies, the statement of the definite quantities required for each plant, he says, is new and valuable. He is of opinion, however, that every soil contains these in sufficient quantity. As to sandy soil not producing wheat for want of alkalies, he says an acre of wheat will not consume above 50 lb. of potash; while an acre of turnips, which agrees with sandy soil, will consume  $92\frac{2}{5}$  lb. The whole four-shift rotation of wheat, barley, hay, and oats consumes 1,091 lb. of saline matter; while the 30 tons of manure given with the turnips, he says, yields 7,324 lb. of saline matter, or 1,556 lb. per annum more than needed. The reviewer proposes to resume the subject again; and, when men of such talent and opportunities for investigation thus devote themselves to such subjects, we are certainly warranted in expecting much valuable insight to be

speedily obtained on the theory of the action of manures, surrounded, though it be, with so many difficulties.

---

ART. III. *The Landscape-Gardening of F. L. von Skell of Munich.*  
Translated from the German for the "Gardener's Magazine."

(Continued from p. 355.)

II. *Selection of Natural Scenes suitable for the Adaptation of the Landscape-Gardener.*

1. NATURE extends her pictures in an endless multitude over our mother earth; and these sometimes exist as they were originally formed, or have undergone a change from the early or recent revolutions of the earth's surface. An infinitely varied flora is found in the different countries that compose the quarters of our globe. All these plants have a peculiar character, and it is but seldom that one is found on a spot in which it will not thrive. The tops of the highest mountains are decorated with a peculiar kind of vegetation, among which many plants are found which may be looked for in vain at the base of these elevations. Some, again, are only found in poor soil, or in moist situations; others on rocks, or in their chinks, or even on plants themselves. Thus Nature operates, and so, also, must those who wish to imitate her.

2. She proceeds almost in the same manner with inorganic form. She produces the most stupendous mountains, the most terrific abysses, the very aspect of which is scarcely supportable by man, plains of immeasurable extent, valleys the ends of which the eye can scarcely reach, oceans of infinite surface, and lakes, with rivers that issue from high mountains as if from the clouds, and seem to be lost in the air. All these gigantic works, however, of the great God of Nature are not within the compass of the landscape-gardener to produce; but where they have been created by Nature, they should gratefully be taken advantage of by art, and joined to its smaller artificial productions, by bringing the romantic distance into harmonious connexion with the garden scene.

3. Nature, however, does not always proceed with such powerful masses. Her highest mountains gradually decrease to the smallest declivity; all of which, from the highest to the lowest, are so harmoniously united by a continuity of wavy lines, that the line of separation is never perceptible.

She also proceeds in the same manner with her valleys, forests, lakes, rivers, streams, and waterfalls: their variety of size and form is endless, and no two are found to have the least resemblance to each other. The landscape-gardener, therefore, may select and create, according to his taste, whatever picture suits

his locality, whether that be small or large, as Nature will acknowledge it, if it is but formed after her laws, and is a romantic picture, resembling her without being overdone.

4. The landscape-gardener ought, therefore, to consider well what natural objects he will give to the space he has to lay out, without producing anything contrary to nature, and without committing [an error of long standing, by crowding objects on a few acres which in nature occupy the space of a mile. Such practices were formerly in use, and gave rise to the idea that the English style of landscape-gardening could not be practised on a small space, but only on one that is flat and large.

But a space, however small, can receive picturesque natural objects, and these can be found without difficulty in Nature herself. A piece of ground may, therefore, be transformed into a garden without reference to the size, so that objects are chosen that Nature would have placed there, and sufficient space allowed for them to have a proper effect and expression.

5. I have laid out a great many small private gardens for my friends in the natural style, and some of them were but the tenth part of an acre, and were only ornamented with roses and jasmines, while others had slender and beautiful trees, and those that were larger had a more varied plantation; and sometimes a small hill was added, with a seat for repose, or a small valley formed, &c.

It is well known to all observers of nature, that very small spots are frequently seen in forests, which are beautifully enchanting, and quite delightful to walk in; and it is such scenes as these that ought to be imitated by the landscape-gardener, in a limited space. The beauty of a natural garden does not arise from its extent of surface, but from its intrinsic artistical value, its beautiful forms and scenes.

6. The landscape-gardener must, therefore, sufficiently take into consideration what he should effect and produce by art, otherwise he will not be successful: and he must also remember that he cannot produce mountains, but only small hills of a height not exceeding more than 20 or 30 feet; and that it is not in his power to create such bold forms of nature, as fearful abysses, and far-projecting rocks, which hasten the steps of the traveller, or lakes and cataracts several miles long, which have already been mentioned as beyond his power of imitating. Such powerful productions of nature only furnish him with models for art; and the most careful imitations neither deceive nor produce the smallest degree of terror.

7. Artificial rivers, also, should never be more than 50 or 80 feet wide; and lakes formed by art should never contain more than 20 or 30 acres. Neither of these objects would appear too

small, because it is well known that they both appear larger from optical deception.

8. No lake ought to be formed that does not contain 18 acres; otherwise it should be a pond, which does not require so great an extent of surface. Rippling brooks winding through forests and groves, sometimes approaching the road, and sometimes retiring in still darkness; brooks that suddenly rush out from among rocks, and then peacefully and quietly glide along till they are gratefully received in the beautiful valleys, where they are confined by banks, which are ornamented with an infinitely rich variety of flowers, thereby rendering the water almost invisible; brooks trickling over rocks, which supply lakes or ponds; and others which, without a gushing sound, flow in solemn silence under over-hanging shrubs, and invite for fishing, rowing, or bathing, are suitable for imitation as welcome objects in a garden, giving to it life and activity. Natural springs, too, should have their place in a garden under beautiful masses of rocks; or they should have an urn, an inscription to love or friendship, or a weeping willow, as all these objects invite to a peculiar kind of repose.

9. Woods, sacred groves, thickets, and flowering shrubs, among which Flora and her children are seen to sport in unrestrained freedom, and surprise the passenger by their agreeable display of colours and delightful perfume; meadows and valleys, with a turf covered with the richest display of flowers; gently sloping hills, crowned, when they are small, with beautiful trees and shrubs; all these, also, belong to the natural garden, and admit of the possibility of imitation.

10. The garden should also contain rocks, however difficult it may be so to arrange and group them as to make them appear as if they had been placed there by nature. I shall hereafter treat of rockwork, when I shall give, from my own experience, instructions for the most natural manner of executing such an undertaking.

11. Grottoes also, although among the most difficult objects of nature to imitate, ought to be included in the garden, and ought never to be excluded from it where there is an opportunity of erecting them. There are several tolerably successful attempts of this kind in England; among which the grotto at Pains Hill, and that at Stourhead near Salisbury, may be reckoned the best. The latter partakes more of art than of nature; which has induced me to believe that the idea and the form have been partially borrowed from the Egerian fountain in Rome. This grotto stands on the banks of a lake; and the back part of it is against a perpendicular rock, formed there by nature, and over which, in former times, a celebrated medicinal water flowed. At the foot of this

rock lies a sleeping nymph (probably *Egeria*), illuminated by a faint light, which breaks in unseen. Near her are inscribed these words, by Alexander Pope : —

“ Nymph of the grot, these springs I keep,  
And to the murmur of these waters sleep.  
Ah ! spare my slumbers, gently tread the cave,  
And drink in silence, or in silence lave.”

The grotto itself is in a quiet solitary shade ; and a deep stillness surrounds the sleeping nymph, which the sensitive wanderer never disturbs by any noise, but retreats from gently and not without heartfelt sensations. A flight of steps lead from this grotto to a height, at the top of which broad daylight bursts upon the sight, and the stranger is agreeably surprised by the aspect of a lake and an enchanting landscape. To accomplish such natural wonders, among which the grotto should certainly be reckoned, and particularly when it is to be on a small scale, the aid of a very experienced landscape-gardener is certainly necessary, and he must be one who has often beheld similar works in nature, and paid great attention to her laws.

Among the most remarkable natural grottoes and caves, the following may be particularly mentioned :

Fingal's Cave in Scotland, Okey Cave in England, the cave at Castleton, St. George's Cave in Gibraltar, Baumann's Cave in the Harz, Rosenmüller's Cave in Mainkreise in Bavaria, the Beatus Cave in Switzerland, the Grotto of Antiparos in the Levant, and the Grotto of Pausilippo in Italy, together with the Grotto del Cane, the vapour of which (carbonic acid gas) is dangerous to dogs ; and to these rare productions of nature, the so-called Rock Theatre at Hellebrunn in Salzburg should be added.

The interior of the natural grotto is distinguished from the cave in a rock by its having generally a variety of crystallisations and petrifications, stalactites or basalt-like pillars, such as those in Fingal's Cave : and in these grottoes the most wonderful appearances are seen, such as long protuberances hanging from the roof, with innumerable prisms, and surrounded by smooth flat surfaces, like looking-glasses, which reflect the most astonishing appearance of light, occasioned by the infinity of reflected rays ; and these pillar-like appendages often reach the floor, and give an appearance as if they supported the roof. The mind fancies such grottoes the abode of nymphs in fairyland.

12. There are also other kinds of grottoes which formerly ornamented the geometric garden, and these were sometimes in buildings, in niches, or by the sides of fountains ; but these grottoes were always grotesque, and never had a natural expression.

Such fantastic forms of architecture, with the varied mixture of the animal, plant, and mineral kingdom, which decorated their walls, evinced but little taste and imagination; but we must not reckon these absurd grottoes and shellworks here spoken of, with the works in mosaic, as they are far inferior to the latter, and, therefore, ought not to find a place in the modern style of gardening.

(*To be continued.*)

---

ART. IV. *Notice of a Visit to Hampton Court, in Herefordshire.*  
By J. B. W.

FOUR or five miles south of Leominster, near the village of Hope-under-Dinmore, stands Hampton Court, formerly the principal residence of the Coningsby family, but now the property of J. Arkwright, Esq. Shortly after that gentleman purchased the estate, the fine old baronial house was in a great measure pulled down, and a magnificent building is now springing up on its site. Unfortunately, however, both for its appearance as a building, and its salubrity as a residence, the situation is low and damp; the river Lugg, which flows past the front, rising in high floods to within a few yards of the house; and this selection is the more to be regretted, because there is said to be an excellent site about half a mile further north, on a high brow, which, besides its superior healthfulness, commands a much wider prospect, the view from the present mansion being confined to one direction by Dinmore Hill, which runs parallel to the front. It has been considered advisable to retain the north front of the old building, through which a lofty archway leads to a court-yard, where there is a private entrance. The principal entrance is under the archway, from which corridors conduct the visitor to the living-rooms.

All the stone used in the building is raised on the estate, and conveyed on a tram-road to the river side, where Mr. Arkwright has erected extensive saw-mills, and all other mechanical apparatus necessary for converting the stone, wood, and even iron, required in the building, to its proper uses. This apparatus is most ingeniously contrived; and, although very costly in its first construction, it has saved an immensity of labour.

The present gardens do not at all correspond in extent with the mansion; but, probably, when the latter is completed, the whole of the grounds will be remodeled in a style worthy of the building. The soil of the kitchen-garden is very good, and, although low and near the river, it is comparatively dry, owing to the subsoil being gravel. There are two vineries, one of which is heated by hot water in a copper apparatus. Most of the walks are formed of flagstones, which, where available, cannot

be too strongly recommended, as being much inferior to gravel, or indeed any other material: such walks are always clean, always firm, and, if properly formed, always dry; and, once made, they will last as long as the garden. The walk that leads from the kitchen to the flower-garden crosses a plot of nursery-ground, beneath an arch of green-gage plum trees, which produce a large quantity of good fruit.

The pleasure-ground is small, and is also rather encumbered with trees, some of which, as the fern-leaved and copper-leaved beeches, cypress, and one cedar of Lebanon, are fine specimens. There are two conservatories in the grounds: one a tawdry specimen on the old plan of upright front lights and opaque roof; the other a large lean-to house, which is about to be taken down, and a new one erected, connected with the new house.

The flower-garden chiefly consists of a group of variously formed beds, surrounding a fountain and a sort of stone grotto. As a proof that some evergreens might be safely transplanted during the season of growth, I may mention that two very large trees of *Magnòlia grandiflòra*, which formerly grew against the old mansion, were successfully removed in the month of June; they have since been transplanted a second time, and are still likely to live. — *Jan. 20. 1841.*

---

ART. V. *On the Propagation of Dahlias.* By R. LYMBURN.

MUCH has been said against nursérymen for their too great avidity in propagating dahlias, and perhaps we may be allowed to say a few words in our own exculpation. It was at first roundly asserted that the roots produced from cuttings would not push next year, and that nurserymen who sold these roots were only deceiving their customers. When it was shown that roots from cuttings did grow, it was next asserted that no cutting roots would spring, unless the cuttings were pulled out by the sockets; and next, that, unless the shoot were pared off quite close to the buds, so as to let them be included in the crown of the root, it would not spring next year. To this it was answered, that, though the shoot were pared quite close to the buds, it would elongate in the act of growing, and the buds would still generally bear the stem; that more than these buds were shown in the root, and often far down in the tubers; and that, consequently and more especially, the buds were formed in the root at the time of ripening, as even old roots on rich land, and not well ripened, did not produce buds. That the vital power residing in the latex, or blood of the plant, is sufficient to form buds, no one can doubt who has observed the matter extravasated at times from the stems of geraniums, dahlias, &c., and the stumps of old trees. At first it is only a



mass of cellular matter, but gradually begins to thicken at the surface, and get of a red and green colour, vessels are seen to be produced and buds organised, which, if placed in favourable circumstances, will evolve into shoots. I have seen the buds literally crowded together like bees in a hive. Dr. Carpenter says that the blood of animals, even when altogether separated and spread out, has been seen to organise vessels, from the strength of the vital principle. We have heard little of these objections lately: but now it has been brought forward in a different shape, and it is asserted, that, in roots from which many cuttings have been taken, the later cuttings will not produce such good flowers; a sort of inexplicable debility has taken place, and though a person has got a strong-growing plant, it is not to be depended on unless he can tell whether it is the first or the hundredth cutting that has been taken off; as if a person ordinarily skilled in plants could not tell a healthy-growing plant when he saw it. It is true that the first cuttings taken off have taken away so much of the starch deposited in the tuber, but the quantity is small. What is the weight of all the cuttings taken off in comparison with the root? The decomposition of the starch is still going on, and new food being produced, and the fibres which the new shoots send out are collecting more. Should it even happen that the last cuttings are weaker, it will be perceived; and, when the active young roots are produced on the weakest cutting, how often have we seen a very diminutive plant, from being in more favourable circumstances, set away with vigour, and soon become a stronger plant than the others. In fact, I have generally found, in my experience, that the very strong shoots are the worst of all to root. As a proof, we have often sold to our customers cuttings taken from the rooted cuttings we got down, which flowered sooner and better than our own plants. I recollect this particularly in the case of Brewer's Rival King, to Mr. Tillery at Fullarton House, now at Welbeck; and to Mr. Buchannau, at Caprington, now in America. The quantity or quality of flowers does not altogether depend on the strength of the plant: the quantity will be increased rather by stunting a very luxuriant plant, and the quality, although depending on luxuriance, does also depend on the former state of the plant; if it has been rather in a starved state when the flower buds are formed, and if plentiful rains occur and heat, or if manure or water be given copiously thereafter, a closer and better flower may be had than if it had always grown luxuriantly. It is a pity poor nurserymen have to come in for the blame, when it is, perhaps, only the state of the weather. Every buyer should let his eyes be judge of the plant, without enquiring whether it is from the first or twentieth dozen of cuttings that has been taken off the root.

*Kilmarnock, June 14. 1841.*

## REVIEWS.

ART. I. *Graphic Illustrations, with Historical and Descriptive Accounts, of Toddington, Gloucestershire, the Seat of Lord Sudeley.* By John Britton, F.S.A., Honorary Member of the Royal Institute of British Architects, and of several other English and Foreign Societies; Author of "The Cathedral and Architectural Antiquities," &c. 4to, pp. 46, 29 plates and 3 woodcuts. London, 1841.

(Continued from p. 369.)

CHAP. II. contains remarks on the scenery and features of a country with reference to domestic architecture and landscape-gardening, and on the old house and garden at Toddington. We quote the greater part of the chapter.

"The natural forms and features of every tract of country in which a gentleman's seat is placed are positive and permanent. They are either mountainous, as in Scotland and Wales; bold, or slightly undulating with hill and dale, as at Toddington; level, or nearly so, as in Middlesex and parts of Essex; abounding with woods and enclosures, as parts of Kent; bare and open, as the plains of Salisbury and Marlborough; or wild, uncultivated, and abounding with heath, furze, and brush-wood, as parts of Surrey and Sussex. Each of these districts exhibits its own exclusive and peculiar characteristic features and expression; and it should be the study of its manorial lord to adapt the style and external forms of his mansion to harmonise with, and make part of, the local scene. Common sense and good taste will dictate this; but we occasionally see glaring incongruities in the adaptation of buildings to their respective localities, as well as violations of all the principles of common sense and taste. Art may adorn and improve all places, either by taking away old woods, or by adding new plantations; by enlarging and varying the boundaries of waters; by forming and planting the courses of roads, and by other means which the skilful landscape-gardener has at his command. He is, however, rarely consulted in the selection of a site for a house, or, indeed, till the proprietor has committed many errors in laying out roads, plantations, water, &c.

"The castles and the monastic buildings of the middle age constitute the principal, if not the only, specimens of ancient domestic architecture in England. These are numerous, and of various dates, and are contra-distinguished from each other by several dissimilarities in general design, in plan, and in subordinate parts. Destined, however, as each was, for its respective inhabitants; adapted as each was to the peculiar customs and manners of its warlike or religious occupants, they had but little analogy to each other, and were ill-suited to the domestic habits of a refined and luxurious community. Hence, both the castle and the monastery have been deserted, and are now only to be seen in ruin, whilst the emancipated lords of the soil have erected for themselves new mansions on their respective estates; and we find that these have commonly been designed in accordance with a particular and prevalent fashion. During the reigns of the later Henries, the monastic architects were employed to erect a few mansions and castles, which still remain to characterise their age and origin. Under Elizabeth, James, and the Charleses, a successive variety was introduced in the styles and features of domestic architecture; but each dynasty is distinguished by its own and decided class. In our own times architecture seems emancipated from the trammels of fashion, and all the formulæ of schools, whilst architects and their employers give full *latitude* to fancy and imagination. Hence we have imitations of Egyptian, Indian, Chinese, Grecian, Roman, and Gothic, with designs that aim at originality by a departure from all precedent, or by blending a heterogeneous mixture of two or more of the ancient styles. If

amidst this medley and this diversity the English architects fail to produce any thing to mark either the particular age in which they live, or the nation to which they belong, we cannot fail to recognise a principle and sentiment characteristic of personal liberty and of the freedom of the government. As every Englishman's home is his castle, he assumes unlimited freedom of action in making it either large or small, highly decorated or plain, of stone, brick, timber, or marble, as may best please his fancy and his station in life.

"The late Mr. Repton, of Hare Street, Essex, was employed during the greater part of an active life, by several English noblemen and gentlemen, to give designs for, or 'lay-out,' the grounds in the vicinity of their respective houses. In prosecuting this very pleasing, indeed fascinating, profession (for Mr. R. had studied and practised it in a professional capacity), he visited most parts of the kingdom, and was engaged to survey and report on some of its finest parks, as well as many subordinate villas. His practice was, to examine the natural and artificial features of a place with its mansion, and to prepare a series of small, but smartly-touched, drawings, showing certain scenes and parts, which he deemed bad or susceptible of improvement on a slip of paper, and to represent his suggested improvement by drawing the same on the paper beneath the said slips. He accompanied these drawings with an essay on the scenic characteristics of the seat; eulogising its grand, fine, picturesque, and beautiful portions, and describing or pointing out such parts as tended to deteriorate the better features of the domain. These drawings and the manuscripts were bound in red morocco, and known as *Mr. Repton's Red Books*. In a published volume entitled *Sketches and Hints on Landscape-Gardening*, 4to, 1795, the author laid before the public the most essential portions of fifty-seven of these red books. 'to establish fixed principles in the art of laying out ground.' The whole of this volume is republished by Mr. Loudon in his interesting edition of Mr. Repton's works, with a memoir of the author, and some valuable notes by the editor.

"The mansion which preceded the present at Toddington was seated in the lowest part of the grounds, adjoining a river, which meanders through the valley, and, like the generality of country seats built at the end of the sixteenth century, it was placed in juxtaposition with the parish church. It was partly bounded by walls, some of which were lofty, and its gardens, which nearly surrounded the house, were laid out with geometric regularity and formality. Gravel walks, and green walks, terraces, fish-ponds, and fountains; clipped hedges and clipped trees; shrubs, with vases and leaden figures, gave to the whole scene a most formal, artificial, and frigid air and aspect. Pope endeavoured to mark this fashion in one of his terse and expressive couplets:—

"Grove nods at grove, each alley has its brother,  
And half the platform just reflects the other."

"But the writings of the poet and the critic cannot convey an adequate idea of this species of country-house and its flower-garden; and I do not believe that there is a genuine specimen remaining in Great Britain. To the topographical draughtsmen and engravers we are obliged and indebted for conveying to our times and to our eyes representations of such gardens with their respective buildings. Burghers, Hollar, Knyff, Badeslade, and the Kips, have left us views of many of them, which are valuable evidences of the prevalent taste, as well as of the manners, of our ancestors. Toddington, amongst these representations, shows the house to be large, bounding three sides of a quadrangular court, and having the fourth side flanked by an embattled wall and a porter's lodge. The church, stables, coach-houses, farm-buildings, and barkens, brew-house, bake-house, and a mill, appear to have constituted parts or appendages of the mansion."

Chap. III. contains a description of the new house at Toddington; and Chap. IV. an account of the manor, parish church, Hailes Abbey, and various

other objects connected with the property ; and at the end there is the pedigree of the family of Tracy.

We give entire the author's concluding address, and again most strongly recommend his work to every country gentleman and amateur.

"I cannot close the present Volume without adverting to circumstances connected with it, which may be said to form part of its annals, and may therefore be regarded as essential items in its composition. After many years devotion to the history and illustration of the *Architectural* and *Cathedral Antiquities of England* (both intimately associated with the history and fine arts of the country), I was naturally tempted to study and examine those modern buildings which professed to imitate, or dared to compete with, edifices which range under those titles. I had published a volume on the noted mansion of *Fonthill*, and had illustrated and criticised other houses of a similar class in different publications. The fame of *Toddington* impelled me to seek an opportunity of viewing its architecture, for it was said to possess much originality of design, with elaborate details, and many peculiarities. This wish was readily gratified by its noble proprietor and architect. For the last four or five years I have occasionally seen it, both in progress and since its completion, and have also had frequent conferences with the noble lord, who has devoted more than twenty years to the pleasing, but anxious, task of directing the whole of the works. To that respected nobleman I now tender grateful thanks for many acts of courtesy and polite attention, and also for the engravings which accompany this volume, which gave it origin, and may be considered to constitute its most attractive portion.

"To Lord Sudeley the public is under obligations which will never be fully known or appreciated. As one of the committee to select from the competing designs for the new Houses of Parliament, his Lordship not only devoted much time and zealous attention, but manifested an intimate knowledge of the science and art of architecture. Whatever differences of opinion prevailed amongst professional architects and legislative critics, on that conflicting occasion, it may be safely predicted, that the designs by Mr. Barry, unanimously fixed on by the Committee, will hereafter be equally an honour to the architect, to England, and to the three distinguished gentlemen who, after choosing the anonymous design, rendered many useful, if not important, hints to the artist. I cannot indulge the hope of living to see that magnificent edifice fully executed ; but I venture to prognosticate that it will hereafter become a subject of national exultation and pride, and also mark an important epoch in the architectural annals of our beloved and illustrious country.

"The present volume has been long in progress, and frequently announced for speedy publication. Repeated attacks of illness have occasioned me to put it aside in different stages of composition. At times of convalescence and health other and more pressing demands engrossed nearly all my time and solicitude, and compelled me to postpone the completion of the work. It is at length submitted to that critical ordeal which I have frequently encountered on preceding publications, and which has very generally been indulgent and flattering. In three instances, however, and by three hostile parties, my critics have indulged in envious and malevolent strictures. Knowing those parties, and pitying their constitutional infirmities, which must entangle their road of life with thorns and nettles, I bequeath to them a sincere wish that they may live to know better, and to act more kindly ; that they may correct, or endeavour to correct, their own bad and perverse tempers ; and, in wielding the pen of criticism, that they treat other authors with a justice and generosity which they themselves have a right to expect from public critics.

"Incidentally becoming connected for the last five years with an unfortunate railway company, I was gradually involved in the loss of much time, and also in nearly the whole savings arising from fifty years of literary labour. These are my painful pleas for delay, and also for those imperfections of authorship which the acute critic may too easily detect, but which it is hoped he will generously be disposed to pardon." (p. 46.)

ART. II. *A Treatise on the Theory and Practice of Landscape-Gardening, adapted to North America; with a View to the Improvement of Country Residences: comprising Historical Notices and General Principles of the Art, Directions for laying out Grounds and arranging Plantations, the Description and Cultivation of Hardy Trees, Decorative Accompaniments to the House and Grounds, the Formation of Pieces of Artificial Water, Flower-Gardens, &c. With Remarks on Rural Architecture.* By A. J. Downing. 8vo, pp. 451, plates, and numerous woodcuts. New York and London, 1841.

A TASTE for rural improvements, Mr. Downing observes, is advancing with great rapidity in America; but, though immense sums are employed, professional talent is seldom required. Every man fancies himself an amateur, and endeavours to plan and arrange his own residence; and the results are, as might be expected, much incongruity, and great waste of time and money. The object of Mr. Downing's volume is to teach amateurs how to proceed in such a manner as, with comparative ease, to produce delightful and satisfactory results. After giving a short historical sketch of the progress of landscape-gardening among mankind generally, and pointing out the superiority of a taste for this art over that of a taste for pictures, he proceeds to show (in p. 19.) the progress of the art in the United States.

"The number of individuals who possess in America," he says, "wealth and refinement sufficient to enable them to enjoy the pleasures of a country life, and who desire in their private residences so much of the beauties of landscape-gardening as may be realised without any enormous expenditure of means, is daily increasing; and, in half a century more, there will exist a greater number of beautiful villas in the Atlantic States than in any other country in Europe, England alone excepted."

The only American work on landscape-gardening is the *American Gardeners' Calendar*, by Bernard M'Mahon of Philadelphia; and the only practitioner of the art, of any note, was the late M. Parmentier of Brooklyn, Long Island.

"M. André Parmentier was the brother of the celebrated horticulturist, the Chevalier Parmentier, Mayor of Enghien, Holland. He emigrated to this country about the year 1824; and, in the horticultural nurseries which he established at Brooklyn, he gave a specimen of the natural style of laying out grounds, combined with a scientific arrangement of plants, which excited public curiosity, and contributed not a little to the dissemination of a taste for the natural mode of landscape-gardening.

"During M. Parmentier's residence on Long Island, he was almost constantly applied to for plans for laying out the grounds of country seats, by persons in various parts of the union, as well as in the immediate proximity of New York. In many cases he not only surveyed the demesne to be improved, but furnished the plants and trees necessary to carry out his plans. Several plans were prepared by him for residences of note in the southern states; and two or three places in Upper Canada, especially near Montreal, were, we believe, laid out by his own hands, and stocked from his nursery grounds. In his periodical catalogue, he arranged the hardy trees and shrubs that flourish in this latitude in classes, according to their height, &c., and published a short treatise on the superior claims of the natural over the formal or geometric style of laying out grounds. In short, we consider M. Parmentier's labours and example as having effected, directly, far more for landscape-gardening in America, than those of any other individual whatever.

"To the novice in landscape-gardening and rural embellishment, nothing is more instructive than a personal inspection of country seats, where the grounds are laid out in a tasteful manner. In examining such, the mind is, at a single view, more fully impressed with the beauties of the art and its capabilities,

than by ten times the amount of time spent in investigating the theory without any such practical illustrations. And although we have but few such as might be termed 'show places,' yet we shall venture to refer the reader to several examples which have considerable reputation among us as elegant country residences.

"*Hyde Park*, on the Hudson, the seat of the late Dr. Hosack, has been justly celebrated as one of the finest specimens of the modern style of landscape-gardening in America. Nature has, indeed, done much for this place, as the grounds are finely varied, beautifully watered by a lively stream, and the views from the neighbourhood of the house itself, including as they do the noble Hudson, and the superb wooded valley which stretches away until bounded at the horizon by the distant summits of the blue Catskills, are unrivalled in picturesque beauty. But the efforts of art are not unworthy so rare a locality; and while the native woods and beautifully undulating grounds are preserved in their original state, the pleasure-grounds, roads, walks, drives, and new plantations, have been laid out in so tasteful a manner as to heighten the charms of nature. Large and costly hot-houses were erected, and elegant entrance-lodges at two points on the estate, a fine bridge over the stream, and numerous pavilions and seats commanding extensive prospects; in short, nothing was spared to render this seat one of the very finest in America. The park, which at one time contained some fine deer, afforded a delightful drive within itself, as the whole estate numbered about seven hundred acres. The plans for laying out the grounds were furnished by Parmentier, and architects from New York were employed in designing and erecting the buildings. Since the death of Dr. Hosack, the place has lost something of the high keeping which it formerly evinced, but we still consider it one of the most instructive seats in this country.

"*Blithewood*, the seat of R. Donaldson, Esq., near Barrytown, on the Hudson River, is one of the most tasteful villa residences in the union. The lawn, or park, which commands a view of surpassing beauty, is studded with groups of fine forest trees, beneath which are delightful walks, leading in easy curves to rustic seats, summer-houses, &c., disposed in secluded spots, or to openings affording the most lovely prospects. In various situations near the house and upon the lawn, Maltese vases, exquisitely sculptured in stone, are disposed in such a manner as to give a classic air to the grounds. The entrance-lodge, built in the English cottage style, is exceedingly neat and appropriate, and the whole place may be considered quite a model of elegant arrangement; such, indeed, as may fairly come within the reach of numbers of our wealthy proprietors, did they possess the *taste*, as well as the means, for this species of refined enjoyment.

"There are one or two old and celebrated country residences on the Hudson, in the possession of the Livingston family, in the neighbourhood of Barrytown. The magnificent single trees, groups, masses, and rolling woods, which seem as if tastefully disposed in the modern style over an extensive undulating park, covered with the finest turf, give these seats very much the air of an old European residence; which, perhaps, they resemble, more than any mansion residences that we have in the United States. These places owe almost their entire beauty to nature, as nearly all the fine trees, groves, and woods are the natural growth of the soil; such as, indeed, once covered many of our fine river valleys, but which have fallen a prey to the licentious axe of the woodman in so many thousand instances. Here, just so much of the natural growth of timber has been retained, as to clothe the estate with a truly noble garniture; and the proportions of meadow, or lawn, and wood, as well as the arrangement and situation of the latter, have been so judiciously managed, that, as we have before mentioned, much of the effect of the finest park, carefully laid out and planted in the modern style of landscape-gardening is produced, mainly by retaining and preserving the materials of which nature has been here so extremely prodigal.

"The gardens and grounds of *Lemon Hill*, once the residence of H. Pratt,

Esq., near Philadelphia, are familiar examples to many of our readers, of the geometric style. These gardens, when in their perfection, some ten years ago, were filled with a collection of the rarest and most costly exotics, as well as a great variety of fine native trees and shrubs, which, interspersed with statues and busts, ponds, *jets d'eau*, and waterworks of various descriptions, produced certainly a very brilliant, though decidedly artificial effect. An extensive range of hot-houses, curious grottoes and spring-houses, as well as every other gardenesque structure, gave variety and interest to this celebrated spot, which we regret the rapidly extending growth, and the mania for improvement there, as in some of our other cities, has now nearly destroyed and obliterated.

“The garden of the Van Rensselaer Manor, near Albany, may be given as another specimen, on a large scale, of the geometric mode of gardening.

“In the suburbs of Boston, a far greater number of elegant country seats of moderate extent are to be found, than in any other equally small neighbourhood in the union. Many of these are, no doubt, familiar to our readers. Among the most celebrated are those of J. P. Cushing, Esq., at Watertown, the Hon. John Lowell at Roxbury, and Col. Perkins at Brookline. These, with many other beautiful villa residences of less extent, are remarkable for elegant arrangement, and for the high keeping of the grounds, as well as the perfection to which the art of gardening is carried within the precincts.\* In short, we consider these places as fine models of a species of country residence which will, undoubtedly, become the most popular in this country. While the extent of ground embraced in these country seats is rarely greater than is easily obtained every where, in situations most desirable in the country, it includes every thing which can render a country seat delightful: beautiful pleasure-grounds, large enough to admit of a park-like character, varied with trees in irregular groups, smooth lawns, and firm gravel roads, and walks; flower and kitchen gardens, well stocked with floral beauties, and the most excellent culinary productions; and hot-houses and forcing-houses, filled with all that can minister to the eye or the palate. In short, this class of residences, while it comes within the reach of such moderate fortunes as are not very rare in a republic, yields to the possessor all that is really gratifying or delightful in the overgrown estates of a titled aristocracy.

“There are several other country residences, which have been quite cele-

\* “We Americans are proverbially impatient of delay, and a few years in prospect appears an endless futurity. So much is this the feeling with many, that we verily believe there are hundreds of our country places, which owe their bareness and destitution of foliage to the idea, so common, that it requires ‘an age’ for forest trees to ‘grow up.’

“The middle-aged man hesitates about the good of planting what he imagines he shall never see arriving at maturity; and even many who are younger conceive that it requires more than an ordinary lifetime to rear a fine wood of planted trees. About two years since, we had the pleasure of visiting the seat of the late Mr. Lowell, whom we found in a green old age, still enjoying, with the enthusiasm of youth, the pleasures of horticulture and a country life. For the information of those who are ever complaining of the tardy pace with which the growth of trees advances, we will here record that we accompanied Mr. L. through a belt of fine woods (skirting part of his residence), near half a mile in length, consisting of almost all our finer hardy trees, many of them apparently full grown, the whole of which had been planted by him when he was thirty-two years old. At that time a solitary elm or two were almost the only trees upon his estate. We can hardly conceive a more rational source of pride or enjoyment, than to be able thus to walk in the decline of years beneath the shadow of umbrageous woods and groves planted by our own hands, and whose growth has become almost identified with our own progress and existence.

brated as specimens of landscape-gardening, and we regret that the limits of a single volume will not permit us to refer to them in detail. Waltham House, about nine miles from Boston, the seat of Theodore Lyman, Esq., has an extensive park, and fine grounds. The seat of Mr. Wadsworth, in the beautiful Genesee Valley, is remarkable for the tasteful design exhibited in the house and grounds. *Monte Video*, the residence of Daniel Wordsworth, Esq., is one of the prettiest residences in Connecticut. The grounds of the Count de Surveilliers, at Bordentown, N. J., are remarkable for their extent; and although the surface is extremely flat, it has been well varied by extensive plantations.

“Of smaller villa residences, suburban chiefly, there are great numbers springing up, almost by magic, in the borders of our towns and cities. Though the possessors of these can scarcely hope to introduce anything approaching to a landscape-garden style, in laying out their limited grounds, still they may be greatly benefited by an acquaintance with the beauties and the pleasures of this species of rural embellishment. When we are once master of the principles, and aware of the capabilities, of an art, we are able to infuse an expression of tasteful design, or an air of more correct elegance, even into the most humble works, or with the most limited means.

“While we shall endeavour, in the following pages, to give such a view of modern landscape-gardening, as will enable the improver to proceed with his fascinating operations in embellishing the country residence, in a practical mode, based upon what are now generally received as the correct principles of the art, we would desire the novice, after making himself acquainted with all that can be acquired from written works within his reach, to strengthen his taste and add to his knowledge, by a practical inspection of the best country seats among us. In an infant state of society, in regard to the fine arts, much will be done in violation of good taste; but here, where nature has done so much for us, there is scarcely a large country residence in the union, from which useful hints in landscape-gardening may not be taken. A natural group of trees, an accidental pond of water, or some equally simple object, may form a study more convincing to the mind of a true admirer of natural beauty, than the most carefully drawn plan, or the most elaborately written description.”

The second section of this work treats of the beauties of landscape-gardening.

“The earliest professors of modern landscape-gardening have generally agreed upon two species of beauty, of which the art is capable — variations no less certainly distinct on the one hand than they are capable of intermingling and combining on the other. These are *general*, or *natural*, and *picturesque* beauty; or, to speak more definitely, the beauty characterised by simple and flowing forms, and the beauty expressed by striking, irregular, spirited forms.

“The admirer of nature, as well as the lover of pictures and engravings, will at once recall to mind examples of scenes distinctly expressive of each of these kinds of beauty. In nature, perhaps, some gently undulating plain covered with emerald turf, partially or entirely encompassed by rich rolling outlines of forest canopy, its widest expanse here broken occasionally by noble groups of round-headed trees, or there interspersed with single specimens, whose elegant trunks support masses of foliage flowing in outline, or gracefully drooping to the very turf beneath them. In such a scene, we behold the azure of heaven, and its silvery clouds, as well as the deep verdure of the luxuriant and shadowy branches, reflected in the placid bosom of a sylvan lake; the shores of the latter jutting out, and receding back, in gently curved lines; the banks, sometimes covered with soft verdure and enamelled with flowers, and in other portions clothed with luxuriant masses of verdant shrubs. Here are all the elements of what is termed natural beauty, — or a landscape characterised by natural, easy, and flowing lines.

“For an example of the opposite character, let us take a stroll to the nearest woody glen in your neighbourhood: perhaps a romantic valley, half



shut in on two or more sides by steep rocky banks, partially concealed and overhung by clustering vines and tangled thickets of deep foliage. Against the sky outline, breaks the wild and irregular form of some old half-decayed tree near by, or the horizontal and unique branches of the larch or the pine, with their strongly marked forms. Rough and irregular stems and trunks, rocks half-covered with mosses and flowering plants, open glades of bright verdure opposed to dark masses of shadowy foliage, form prominent objects in the foreground. If water enliven the scene, we shall hear the murmur of the noisy brook, or the cool dashing of the cascade, as it leaps over the rocky barrier. Let the stream turn the ancient and well-worn wheel of the old mill in the middle ground, and we shall have an illustration of picturesque beauty, not the less striking from its familiarity to every one.

“To the lover of the fine arts, the name of Claude Lorraine cannot fail to suggest examples of beauty in its purest and most elegant forms. In the inimitable landscapes which are the works of this great master, we see portrayed all those graceful and flowing forms, and all that harmonious colouring, which delight so much the mind of genuine taste and sensibility, and which, based upon a study of beautiful nature and art, in the finest portion of the globe, have never since, and may, perhaps, never again, be equalled.

“On the other hand, where shall we find all the elements of the picturesque more graphically combined than in the vigorous landscapes of Salvator Rosa. In those rugged scenes, even the lawless aspects of his favourite robbers and banditti are not more spirited than the bold rocks and wild passes by which they are surrounded. And in the productions of his pencil, we see the influence of a romantic and vigorous imagination, nursed amid scenes teeming with the grand as well as the picturesque — both of which he embodied in the most striking manner.

“In giving these illustrations of general, or natural, and of picturesque beauty, we have not intended them to be understood in the light of exact models for imitation in landscape-gardening — only as striking examples of expression in natural scenery. Although in nature many landscapes partake in a certain degree of both these kinds of beauty, yet it is no doubt true that the effect is more satisfactory where either the one or the other character predominates. The accomplished amateur should be able to seize at once upon the characteristics of these two species of beauty in all scenery. To assist the reader in this kind of discrimination, we shall keep these expressions constantly in view, and we hope we shall be able fully to illustrate the difference in the expression of even single trees, in this respect. A few strongly marked objects, either picturesque or simply beautiful, will often confer their character upon a whole landscape, as the destruction of a single group of bold rocks covered with wood may render a scene, once picturesque, completely insipid.

“A question that may not be unlikely to occur to the novice in these matters is, which is the superior character of landscape, considered in reference to the art now before us? To answer this question directly, would be to side with one or the other of the two schools or parties in landscape-gardening, which waged battle so fiercely in England during the last century, — viz. the Picturesque School, at the head of which were Price and Knight, and the more formal school, whose champions were Brown and Repton; the former desiring to see all country residences highly picturesque, and the latter, perhaps, verging too much into the rules of an unvarying art.

“There can, however, be little doubt that it is requisite to possess a greater degree of imagination, and perhaps more of that vigour of mind termed genius, fully to appreciate the beauty of the more picturesque forms of nature. Even among artists, while there are many who are able to feel and portray nature in her ordinary developments, how few can make the canvass glow with the expression of her grander and more picturesque beauties! And among mere admirers, it is the multitude that see and feel the power of beauty in her graceful and flowing forms; but only the imaginative and cultivated few, who

appreciate her more free and spirited charms. So, also, there are, perhaps, a thousand who admire the elegant forms and the undulating outlines which predominate in the park or pleasure-grounds, as we generally see them, where there is one who would prefer a cottage in a highly irregular and picturesque valley, or a castle on a rocky crag; though the latter may, to certain minds, be a thousand times more enchanting.

"After having familiarised ourselves with the leading expressions of beauty in wild scenery, the question arises, In what manner is nature to be imitated in landscape-gardening? To produce an actual fac-simile of nature, in the grounds of a country residence, appears to have been the sole idea of some of the early writers on the natural style. These, tired of the formalities of Geometric Gardening, almost ran into the opposite extreme, of rendering the pleasure-grounds like a wild dingle, forgetting that the principles of imitation common to the other fine arts are, to a certain extent, equally applicable to this; and that, although fac-simile imitations of nature are really capable of affording much rational pleasure, yet they have no claim to be considered as the production of an imitative fine art. The pleasure they give rise to being precisely that afforded by natural scenery.

"M. Quatremere de Quincy has defined the end of imitation to be, 'to present to the senses and the mind, through the intervention of the fine arts, images which, in all the different forms of imitation, shall furnish an aggregate of perfection and ideal beauty to which particular models afford no equal.'\* In this sentence may be found the true nature of imitation in landscape-gardening, only partially known and acted upon by its earlier professors.

"The most elevated kind of beauty in landscapes, of whatever description, is undoubtedly that of *expression*; and the highest imitative effects of the art, therefore, consist in arranging the materials, so as to create emotions of grace, elegance, picturesqueness, or grandeur, joined with unity, harmony, and variety, more distinct and more forcible than are suggested by natural scenery, producing, by this means, intellectual gratification, separate and distinct from that arising from the mere admiration of forms or materials employed.

"The *beau ideal* in landscape-gardening, as a fine art, appears to us to be embraced in the creation of scenery expressive of a peculiar kind of beauty, as the elegant or picturesque, the materials of which are, to a certain extent, different from those in wild nature, being composed of the floral and arboricultural riches of *all climates*, as far as possible, — uniting in the same scene a richness and a variety never to be found in any one portion of nature; — a scene characterised as a work of art, by the variety of the materials, as foreign trees, plants, &c., and by the polish and keeping of the grounds, in the natural style, as distinctly as by the uniform and symmetrical arrangement, in the ancient style.

"A fac-simile imitation of nature in gardening, that is, a scene like wild nature, in which only wild trees, shrubs, and plants are employed, and which is precisely like wild nature, produces pleasure only as it deceives us, and appears to be nature itself. An artistical imitation affords pleasure to the mind, not only by the expressions of natural beauty which we discover in it, but by the more novel and choicer forms in which they are displayed, and by the tasteful art apparent in the arrangement. The relative merits of the two may be illustrated, by comparing the first to the counterfeit of the human figure in wax, which, at a short distance, may be thought real, and the last, to the painted landscape or the marble statue. The two latter are no less imitations of nature than the former, but they are expressive and elegant imitations only, which are never to be mistaken for the originals, as in the case of the wax figure.†

\* "Essay on Imitation in the Fine Arts, p. 150.

† "Thus, there is a beauty of nature and a beauty of art. To copy the beauty of nature cannot be called being an artist, in the highest sense of the

“ One of the chief elements of artistical imitation in landscape-gardening being a difference in the materials employed in the imitation of nature from those in nature herself, nothing can be more apparent than the necessity of introducing largely exotic ornamental trees, shrubs, and plants, instead of those of indigenous growth. Thus, to take the simplest example, if we suppose a lawn of an acre, arranged with groups of trees, the groups composed of lindens, horsechestnuts, and magnolias, where the native forests are only filled with oak and ash trees, the variety of the foliage and blossoms alone will at once suggest the recognition of art. Borders of rare flowers and climbing plants, — gravel walks, in the place of common paths or roads, — smooth turf, instead of wild meadow, — elegant vases and architectural ornaments, with many other accessories, bespeaking the presence of a tasteful and enlightened mind ; all these are the essential characteristics of landscape-gardening, considered as an art of imitation.

“ Besides picturesque and beautiful imitations of nature, another mode has recently arisen in England, which Mr. Loudon has very appropriately named the *gardenesque* style. The style is evidently founded rather upon a cultivated taste for botany and horticulture, and a desire to exhibit every variety of rare ornamental tree and plant, than upon any new element of design. As its characteristic features are little known here, we shall place them before the reader, as they have been delineated by Mr. Loudon.”

## MISCELLANEOUS INTELLIGENCE.

### ART. I. *General Notices.*

*INSECTS on Plants.* — Mr. Knight of the King’s Road, Chelsea, an able cultivator of all the rarest exotics, after trying various expedients for banishing the red spider from his hothouses, thought of a plan which effectually clears the plants from dust as well as insects. He makes a solution of glue in warm water, in large tubs ; and, when sufficiently diluted by additions of warm water, and while yet hot, the whole infested plant is plunged into the liquid, and immediately returned to its place in the house. Thus a thin coat of the solution remains on every part of the plant, encasing every insect in an investment in which they can neither breathe, eat, nor move. The vestment hardens as it cools ; and, after a day or two, it cracks and peels off the plant, bringing with it every insect which it involved. This dipping, it will be observed, can only be performed on portable plants, or such as occupy pots or boxes not heavier than what two men can carry in their arms. On large specimens, as orange trees and the like, the solution must be thrown on with a syringe, or applied with a soft brush. (*Cambridge Chronicle and Journal*, May 1. 1841.)

word, as a mechanical talent only is requisite for this. The beautiful in art depends on ideas, and the true artist, therefore, must possess, together with the talent for technical execution, that genial power which revels freely in rich forms, and is capable of producing and animating them. It is by this that the merit of the artist and his production is to be judged ; and these cannot be properly estimated among those barren copyists which we find so many of our flower, landscape, and portrait painters to be. But the artist stands much higher in the scale, who, though a copyist of visible nature, is capable of seizing it with poetic feeling, and representing it in its more dignified sense : such, for example, as Raphael, Poussin, Claude, &c.’ — *Weinbrenner*, as translated in *Loudon’s Architectural Magazine*, vol. v. p. 397.”

ART. II. *Foreign Notices.*

## NORTH AMERICA.

PHILADELPHIA, May 19. 1841. — I have the pleasure to acknowledge the receipt of your interesting description of the Derby Arboretum. This gift of Mr. Strutt is, indeed, a splendid one, and the inhabitants of Derby will ever have reason to hold the munificent donor in grateful remembrance. I have made a brief notice of it in the *Journal of the Franklin Institute*, a copy of which I herewith send you.

You would probably be disappointed to receive a letter from an architect on this side of "the water," in these disastrous times, without some allusion to the effect of the recent convulsions in money matters on architecture; allow me then to tell you briefly how the matter stands with us. The derangement of the currency of the country, the depreciation in the value of securities, resulting mainly from the suspension of public works before they could be made productive by completion, and a thousand other ills consequent on a general loss of confidence, have produced a panic throughout the land which seems to have led every body to repudiate (for the present at least) all ideas of luxury, and to confine their expenditures to the absolute necessities of life; the consequence is, that architects have now but little to do, beyond what the mere *utile* dictates. Most of the public edifices which were begun before the storm set in are, however, still advancing towards completion, though in most instances their progress is much retarded by the narrow limits to which appropriations are necessarily confined.

These troubles seem to have been felt more severely in Philadelphia than any where else. The location of the unfortunate United States Bank among us, and the implicit confidence our citizens had in that Institution, led so many to invest their funds in it, that the shock is now felt, either directly or indirectly, by every man in the community. The temporary embarrassment of our state has also imposed an onerous weight on Philadelphia; the focus of the financial concerns of Pennsylvania is in fact in this city, notwithstanding the seat of government is at Harrisburg, 100 miles west of us. Our state debts amount now to about forty millions of dollars, and, in consequence of so many of our public works being arrested in an unfinished state by the scarcity of money, the proceeds that now arise from them fall short of the annual expenditures about half a million of dollars, to say nothing of the interest. In view of these circumstances you will not think it wonderful that so great a change has come over the spirit of our dreams, and that the people have fallen *en masse* into such a dreadful fit of economy. But these things are not to last long. Pennsylvania will come out of the alembic of misfortune, refined and purified. Already has she provided by direct taxation for an amount far beyond her interest and other expenditures; the whole forty millions, principal and interest, must and will be paid, every cent of it, and that too by the people. Every one of our public works, extensive as they are, will assuredly be finished, and that before a great while. Even the peaceful arts will soon be found to make head once more against all adverse influences: they have heretofore taken a strong, a lasting hold on the community; and minds once trained to a perception of the chaste and beautiful, once imbued with a relish for intellectual enjoyment, can never again be satisfied with coarseness and vulgarity. A thousand such minds we have now around us, and there can be no doubt that in a little while we shall all be once more prosperous and happy. Many of our best states are, even now, wholly out of debt; and could the present situation of our own Pennsylvania be calmly looked at, without bringing it into contrast with the wonderful and overwrought prosperity of the last few years, all the consternation and dismay which seems now to cloud our horizon with impenetrable gloom would at once be dissipated.

I intended, when I began, to have told you many things about the Girard College, as I know you feel an interest in the work, and as my own anxiety to bring it to a completion worthy of my profession and my country makes it the most prominent object of my thoughts and my life; but I have already exceeded all bounds, and taxed your patience as far as would now be proper, I shall therefore detain you with but a few brief allusions to it. Both of the flanks of the main building are now completed, including the four corner columns, and the scaffolding is removed, the effect of the architecture is fully equal to my expectations, the whiteness of the marble, the large masses in which it is used, some of the column blocks being upwards of 6 ft. in length, and 6 ft. in diameter, and the great accuracy with which the joints are made, add immensely to the effect. I propose this season to finish the capitals for the end columns, and put on the roof of the cell, a large portion of the tiles for which are already prepared. In the design of the roof I have followed the Greeks in their plan of those at Eleusis, making the tiles 4 ft. by 4 ft. 6 in., and 3 in. thick. As this part of the building is somewhat of an out of the way affair for modern times, I intend to take another opportunity to tell you more about it.—*T. U. W.*

---

### ART. III. *Domestic Notices.*

#### ENGLAND.

*Pinus Lambertiana.* (Extract of a letter from J. H. to Sir J. H.)—You mentioned to me that you were acquainted with Mr. Lambert, and, if you happen to see him in town, you may let him know that I have just received from my friend, Dr. M'Loughlin (who resides at Fort Vancouver, on the River Columbia, on the Pacific side of North America), a parcel of the cones of the Lambert pine, in good order and preservation, seeds and all. They are not so large, however, as a few I had some years ago, and one of which I gave to Mr. Lambert through our friend Mr. Ward of Kew Green. The dimensions of the Lambert pine are enormous, and I fancy there grows no tree in the globe so large. M'Loughlin told me that poor Douglas the naturalist, who was killed some years ago when exploring the woods in his botanical pursuits, by falling into a concealed pit made for the purpose of catching the wild bulls in the Sandwich Islands, where one of them happened to be, and which killed him, had measured one of these trees that he had found blown down in North America, the dimensions of which were as follows: the circumference at the ground was 52 ft., and at 250 ft. from that, where the trunk at the top was broken off, and the top carried away by the water, it was still 13 ft. in circumference. Sir George Simpson also told me that he had found a Lambert pine blown down at Puget Sound Portage. The trunk, from the root to the place where the branches grew at the top, measured 90 of his paces, say about 250 ft. Mr. M'Millan also paced it, but made it a few paces less; but he was a taller man than Simpson. The circumference, about 8 ft. from the ground, where the trunk was broken off, measured 45 ft. These pines are to be found chiefly in the country bordering the Umpqua, or Wallamatte River, that runs into the Columbia from the south.—*J. H. Richmond Hill, June 15. 1841.*

---

### ART. IV. *Retrospective Criticism.*

*MR. NIVEN'S Stove for various Purposes.* (p. 334. 234. 49.)—To enter into a discussion with Mr. Niven relative to the objections I have to his stove, &c.,

would be, I should consider, to the practical portion of the readers of your Magazine, only to insult their understanding; as Mr. Niven's stove, and the arrangements therein, to any practical man, form a palpable absurdity. Whence is it, I would ask Mr. Niven, that, on visiting the gardens of the amateur, we are greeted with constant complaints as a cause of failure, both in their attempts at growing fruit and plants, but from their being obliged to crowd into the same house plants whose treatment ought to be (and is, when convenience will permit) as foreign to each other, as that of the lichen from the Lapland rocks to the Orchidaceæ from the jungle of Sierra Leone? Such, then, nearly is Mr. Niven's assemblage. His stove is the general receiver of the vegetable kingdom from all parts of the known world. His chance of success I shall leave to any rational person to judge.—*Catius. Belfast, June 22. 1841.*

[The author of this complains that we omitted a part of his first letter, which we did; because the terms in which it was couched were such as we did not consider admissible unless he had given his real name. He also says that he thinks we promised in one of our early Volumes to insert every thing that was sent to us, verbatim; an idea that never once was entertained by us, nor, we believe, any other editor.—*Cond.*]

---

#### ART. V. *Queries and Answers.*

*MUSA Cavendishii* as a substitute for Pines. (p. 334.)—In answer to your correspondent, "I. S., Durham," respecting *Musa Cavendishii*. A house of the dimensions he has given will hold about ten full-grown or fruiting plants, with room between for different-sized successional ones, to be tubbed successively, as the large plants ripen off their fruit, these being shaken out of their tubs as soon as the fruit is gathered, and potted, to produce suckers; by judicious management in tubbing and in administering water, a supply of fruit may be had the greater part of the year. I have had at one time ten fruiting plants nearly of the same size and age, being suckers produced the same spring, and receiving similar treatment; yet no two of them produced their spadix at the same time, and even if they were disposed to do so, it may be prevented, different treatment being given them. As their approach to fruiting is easily ascertained, by their leaves decreasing in size, soon after which the embryo fruit-stalk may be detected by the sudden swelling of the lower part of the stem, if more than one should show these indications at one time, the one it is desired to fruit first must have abundance of water, and the warmest situation, and the others be retarded by opposite treatment. The period between them may be still further lengthened a considerable time, if the whole spadix of fruit of one approaching too close upon another in ripening be cut off with a portion of the stem attached, when the upper tier of fruit is just ripening, and suspended in a dry and airy room, in the way that late grapes are often kept. I have cut excellent fruit from a spadix, two months after it had been separated from the plant; and they may be made to ripen fast or slow in this manner, according to the temperature to which they are exposed. The quicker the flower-stem is made to develop itself, the longer the spadix will be, and the greater quantity of fertile flowers it will produce, consequently the greater weight of fruit, which will vary from 15 lb. to 30 lb., according to the plant's strength, the season, and other circumstances.

I need hardly add that the soil can scarcely be too rich, and rather light than retentive; that abundance of water may be given, and readily pass off.—*Joseph Paxton. Chatsworth Gardens, June 22. 1841.*

---

THE  
GARDENER'S MAGAZINE,  
SEPTEMBER, 1841.

---

ORIGINAL COMMUNICATIONS.

ART. I. *Dr. Arnott's Stoves applied to the Heating of Plant-houses.*  
By W. H. BAXTER.

SINCE the enquiry respecting these stoves was inserted in the *Gardener's Magazine*, vol. xv. p. 94., they have been adopted here, in a conservatory which was then undergoing repair, and also in a new greenhouse which was erected soon afterwards. In the conservatory they have been worked two winters, and in the greenhouse the past winter only; but as they have, in both instances, received very constant attention, with a view of ascertaining their merits, &c., in this particular application, I think I may hope to give you a pretty correct and impartial idea of their fitness for the purpose, by stating the description and extent of the houses in which they are placed, the size and kind of the stoves in use, with the average consumption of fuel in severe weather, and also a register of the thermometer in the open air, in the greenhouse, and in the conservatory, for a certain time.

The conservatory is a large substantial stone building, with nine large sash windows in the frontage, which have inside shutters; and the glass span-roof is also sheltered in some degree by a parapet wall, which rises about 2 ft. above the gutters. It is 56 ft. in length, and 21 ft. in height, and contains about 17,200 cubic feet of air. The greenhouse, being a new erection, is, with the exception of the back wall, entirely of framework and glass, and has had no artificial shelter. It is 48 ft. in length, and contains about 7,500 cubic feet of air.

In each house there are two stoves, with thermometer regulators; they are made of strong sheet iron of these dimensions: height  $2\frac{1}{2}$  ft., length from side to side 3 ft., width from front to back  $1\frac{3}{4}$  ft. On the top of each is kept a good supply of water in zinc troughs. In both houses the stoves are similarly placed, being set back 1 ft. from the face of the back walls in recesses cut to receive them, at distances from each other of one third the entire length of each house. Cast-iron pipes carry off the smoke, and terminate in a chimney in the centre of the back wall of each house. In the conservatory, these pipes project from the wall, but in the greenhouse they are embedded in it, which is the only difference in the setting of the stoves in the two houses.

By frequent attention, and a good supply of coals, to the  
1841.—IX. 3d Ser.

amount of about half a cwt. every twenty-four hours for each stove, the heat has been kept up pretty successfully; and during the time they have been in use here, although the situation is low and damp, scarcely any plants have damped off in the houses where they are; but from the great escape of smoke and dust in lighting, and at each making up of the fires, which averaged, during severe weather, not less than six or seven times every twenty-four hours, the plants became clothed with a most unsightly black coat of dust, which was not easily removed, and was in many instances, as in the pelargoniums, &c., retained till out-grown. The hours for making up the fires, to keep up as regular a heat as could be procured, were found to be about the following: 8 o'clock A. M., between 11 and 12 at noon, 3 P. M., between 5 and 6 P. M., 9 P. M., and between 11 and 12 o'clock at night.

January having been the coldest month during the past winter, I have chosen the register of the thermometer for the coldest part of that month, to show more clearly the amount of heat that these stoves, with the above attendance, are capable of supplying.

| Time.           | Open air. | Greenhouse. | Conservatory. |
|-----------------|-----------|-------------|---------------|
| Jan. 3. 8 morn. | 36°       | 43°         | 44°           |
| 10 night        | 28·5      | 44          | 43            |
| 4. 8 morn.      | 30        | 43          | 43            |
| 9½ night        | 31        | 48          | 44            |
| 5. 8 morn.      | 27        | 41          | 42            |
| 11 night        | 28        | 48          | 42            |
| 6. 8 morn.      | 27        | 42          | 42            |
| 9 night         | 17        | 45          | —             |
| 11½ night       | 19        | 44·5        | 42            |
| 7. 8 morn.      | 15·5      | 42·5        | 42            |
| 5 P.M.          | 19        | 46          | 42            |
| 9 night         | 16        | 46          | 42            |
| 12 night        | 16·5      | 45          | 42            |
| 8. 8 morn.      | 8         | 37          | 38            |
| 8½ night        | 10        | 43          | 40            |
| 12 night        | 8         | 40          | 38            |
| 9. 7 morn.      | 14        | 42          | 38            |
| 9 night         | 30        | 45          | 42            |
| 10. 8½ morn.    | 32        | 43          | 42            |
| 9 night         | 30        | 42          | 40            |
| 11. 8 morn.     | 32        | 42          | 40            |
| 9½ night        | 30        | 49          | 46            |
| 12. 8 morn.     | 30        | 43          | 44            |
| 9 night         | 29        | 51          | 48            |
| 13. 8 morn.     | 23        | 41          | 43            |
| 9½ night        | 34        | 49          | 46            |
| 14. 8 morn.     | 33        | 42          | 42            |
| 9 night         | 32        | 45          | 44            |
| 15. 9 morn.     | 34        | 41          | 42            |
| 9 night         | 33        | 46          | 44            |

*Botanic Garden, Oxford, Aug. 1841.*



ART. II. *Importance of Geology, as a Study for Gardeners.*

By PETER MACKENZIE.

It has been said by an eminent philosopher, that "man is the servant and interpreter of Nature." I am not aware of any class of men that have better opportunities for studying the wide field of created objects, and making that knowledge bear upon the welfare of their fellow-men, than gardeners. The situation in which they are placed by Providence affords them facilities for unfolding many of the secret workings of Nature that must be diligently sought after to be rightly understood. Their own existence in a great measure depends upon observation and experiment; and the more these are directed in a right course, in proportion will their own advantage and that of their employers be furthered. How necessary, then, must it be for them to endeavour to trace the relation which one department of creation has with another! Geology, that noble and interesting branch of knowledge, ought to form part of a gardener's study. It not unfrequently happens that gardeners have to remove from one district of country to another: at one time they may be working in soil that is chiefly formed by the disintegration of granite and gneiss and mica slate; at another time it may be that sort of soil the earthy ingredients of which may be composed almost entirely of sandstone or amorphous trap; or it may be a calcareous soil, or those that are formed by diluvial or alluvial deposits. It is well known that different varieties of soil require different treatment; and how to treat them in the best way ought to be the object of every cultivator of the soil. And while they are actively engaged in acquiring knowledge for themselves, they may at the same time be the means of extending the knowledge of geology to others. Those who are placed upon the grauwacké group may be useful in collecting remains of the *Algæ*, *Filices*, *Equisetaceæ*, and *Lycopodiaceæ* of a former world. Others, on the carbonaceous formation, could direct their attention to the *Coniferae*, *Cactææ*, and *Euphorbiaceæ*. With a little perseverance, they might obtain knowledge that would enable them to stand upright in the presence of closeted philosophers, and exchange information with any F.R.S. they might come in contact with. While they may become the auxiliaries of such men as Buckland and Lyell, and Murchison, on the one hand, they may on the other, be the means of sowing the seeds of useful instruction among a rural population, and leading their minds to closer contact with the works of their great Preserver and Benefactor; and thus, by the subordinate agency of gardeners, many may be turned from grovelling pursuits to seek higher and more ennobling food to nourish their immortal minds.

*West Pleas, August 13, 1841.*

ART. III. *Some Account of a Pit for preserving Ice, in Use at Erskine House, Renfrewshire.* By G. SHIELLS, Gardener there.

IN compliance with your request, I send you some account of our ice-pit, beginning with a statement of the circumstances which led to its adoption; the ice-house here is of the common form, but placed unfortunately in a damp situation, and consequently had failed in keeping ice throughout the season. Mr. Middleton, gardener at Blythwood, had, in consequence of the ice-house there not keeping ice well, dug two pits in a sandy bank by the side of a deep sunk fence, in which he succeeded in preserving ice through the season. These pits are about 14 or 15 feet in diameter at top, but much narrower at bottom, and about 7 ft. deep. I think there are drains leading from the bottoms of these pits to the sunk fence. Previously to putting in the ice, the bottoms of the pits are covered with pieces of wood, over which are laid faggots or small branches; the ice has no other covering or protection than 12 or 15 inches in depth of soft peat or bog earth laid over the top, in close contact with the ice. Although only a few yards separate, ice keeps much better in the one pit than in the other.

Previously to making our pit, I went to examine those at Blythwood; this was in 1837. The idea struck me that a gravelly soil might suit better than sand, as being more free of moisture; also that a light temporary covering might be advantageous in preserving the ice from excess of moisture in rainy weather, especially when the moss cracks and opens as the ice subsides, and also for the convenience of taking out the ice in wet weather, and keeping it clean. Under this idea, we had a pit dug on the top of a gravelly bank having a north exposure, surrounded by large forest trees, which shaded it completely from the sun in summer: its dimensions are 16 ft. in diameter at top, and about 10 ft. at the bottom, by 8 ft. in depth. As no water remained standing long in the bottom after a heavy shower, no drain was required, otherwise a drain would have been necessary; which, however, should be completely filled with small gravel, to prevent, as much as possible, the cold air from ascending through it. In the bottom are laid branches of trees or young trees, from 4 in. to 8 in. in diameter, which are covered with small branches or faggots for the ice to rest upon; it also serves as a drain.

During severe frost we fill the pit. The ice is well broken, and rammed close; that broken small being occasionally scattered over that not so finely broken, to fill up the interstices. To aid in consolidating the whole, water is poured upon it from time to time from the rose of a watering-pot; in filling the pit, we generally use two large puncheonfuls. The ice is raised 3 ft. above the surface of the ground. At finishing we give it an extra

watering and beating, leaving it uncovered all night, if the frost is likely to continue. Next day we cover the surface with soft peat or bog earth to the depth of 12 or 15 inches, afterwards a few rafters and spars are put over the ice and lightly thatched with reeds. Our pit has now been in operation upwards of three years, and has kept the ice well. We generally open it in June (having a small heap piled up on the surface of the ground, and covered with moss, which serves till that time), by clearing off a part of the moss, which is not again replaced, as it would soil the ice. Sometimes a bundle of straw is put over the opening, but we generally leave it uncovered, the ice protruding through the moss like a block of marble, for we feel no apprehension of a deficiency. At the end of the year, or when we clear out the moss to prepare for putting in new ice, there is generally 3 or 4 feet of the old ice remaining, over which we put the new ice; last winter we had all the old ice taken out, to examine the bottom and renew the wood, if necessary. The moss is dug from a bog, carted forward, and laid on damp: the same moss has served to cover the pit for three years, it gets mixed with the leaves, but that appears to do no harm; perhaps half-wetted leaves might be a substitute where moss cannot be obtained. In bringing forward the ice we generally empty the carts into the pit at once, and there spread and break it; the three leading points being simplicity, cheapness, and efficiency.

*Erskine House Gardens, July 29. 1841.*

---

ART. IV. *On Mr. Gavin Cree's System of Pruning Forest Trees.*

HAVING lately had an opportunity of inspecting some trees which had been for twenty years subjected to Mr. Cree's system of pruning, under the immediate direction of Mr. Cree himself, we have formed a very high opinion of its importance, in the case of plantations made with a view to profit, and we intend to make it as widely known as our means will permit. We insert, in the meantime, two articles which we have received from Mr. Cree, and his papers on the subject published in the *Quarterly Journal of Agriculture*, and after we have examined some of the trees referred to in the first of these articles, we shall have something further to say on the subject. —*Cond.*

*Edinburgh, August 10. 1841.*

*An Outline of Gavin Cree's System of Pruning Forest Trees.*

ARBORICULTURE affords a never-failing source of pleasure to the planter, while its effects give beauty to the landscape. In dropping the acorn, we should not forget that its offspring ought

to be cherished and cultivated, that it may more surely arrive at that heart of oak, emblematic of the bravery of our people, and which has ever been an ornament and a bulwark of defence to our land. We intend to give an outline of a method by which trees may be successfully cultivated, and some of our reasons to prove that method to be judicious. To cultivate wood on physiological principles, it is necessary to have a knowledge of the organs which constitute the internal and external structure of trees, and of the various functions that these organs perform through the instrumentality of external agents. Trees are generally treated as if they were mere inorganic matter; they are operated on as the ploughman operates on the ground, or as the carpenter and blacksmith on the wood or iron under their hands. Many eminent men have written treatises on vegetable anatomy and physiology, and many have promulgated their notions on the pruning of forest trees, while neither party understood how the science of vegetable physiology ought to direct the mechanical operation of pruning, so as to make it affect, to the greatest extent, the growth and health of the tree. There is in trees, as in animals, a vital power which presides over all their functions. This power is the agent by which the ascent and descent of the sap is produced, and certain internal and external causes facilitate the exercise of this phenomenon. Among the external causes is to be ranked the influence of air, heat, light, and moisture, and the system of operating on the lateral branches by shortening them.

I shall give an outline of the principles which led me to the conviction that the system of pruning by shortening the lateral branches, which I brought forward a number of years ago, is calculated, more than any other, to secure for the benefit of the tree an extra nourishment.

The organs of nutrition or vegetation have one common object to support, namely, life in the vegetable; and the power of these organs may be greatly increased by mechanical means. In order to use these means in a way to assist nature, some knowledge of the physiology of plants is requisite; either the operator or the superintendant must understand how the organs exert their functions, otherwise they cannot reasonably expect to be successful. The different processes of the sap (or vegetative blood) of trees must especially be carefully studied, as by it their growth and vigour are sustained. The sap is acquired and influenced by diverse ways. In spring, the small spongellets or extremities of the roots absorb the fluids and gases from the soil, which are conveyed by an inherent power depending on the life of the tree, or, more properly, the ascending sap is acted on through the roots by atmospheric pressure, up through the capillary tubes, till it reaches the extreme ramification of

the stem, shooting forth buds and expanding leaves. The common sap, having extended over all the branches, mingles with the fluid absorbed by the leaves, and, losing the watery and aëriform principles, which are useless for nutrition, by evaporation, it returns down the vessels of the bark, and in its course deposits cambium, which forms the annual rings of wood, then extends to and strengthens the extremities of the rootlets, whereby they are made to extract more nourishment from the soil throughout the season, and, as the two saps commingle in the leaves, the descending sap, which has not been deposited, in like manner mixes with that extracted by the rootlets, and is again carried up with the ascending sap.

How to economise these fluids for the advantage of the tree is next to be considered. It is obvious, then, that when the upper lateral branches are shortened to half the length of the leading stem, and the others proportionally, the sap has less superficies to cover than when they are allowed to extend to an improper length and thickness; in consequence, there is a greater supply for every part of the tree; and as other fluids, such as water, moving in a channel, acquire additional momentum when augmented, greater vigour and velocity of movement are imparted to the sap by the abundance of quantity; and so great is the beneficial effect resulting therefrom to the tree, that, from the extraordinary size and health of the foliage which clothes the branches, it attracts more than three times the nourishment ordinarily imbibed from the atmosphere under different management.

The branches which are shortened always remain slender. By reason of the small superficies of the branch, and the rapidity with which the sap moves, very little of it is retained by the branch, and of course nearly the whole is deposited in the body of the tree. This truth, with the fact that the foliage remains nearly a month longer on the trees so shortened than on others, accounts for the wonderful rapidity of growth effected by this method of pruning. The smallness of the branches is of advantage likewise when it is necessary to prune close to the stem, as the wound made by that operation is proportionally small, and may be expected to cicatrise in the course of three years.

It may be worth remarking, that, if the branches are properly shortened, trees never become what is termed hidebound. In the royal forests, Lord Glenbervie had instruments for ripping the bark of oaks (which never could increase nutrition), and scraping off the lichens; but had the branches been judiciously shortened, the descending sap would have been so augmented, through means of a more healthy foliage, as to have obviated the disease; as the bark expands in proportion to the quantity and quality of sap carried down, and if that be abundant,

it soon clears itself of all impurities. Even mismanaged trees, on which a dryness of bark has occurred, may be brought to a proper condition in the course of three seasons. In cases of this kind, the distance from the body at which the branches are amputated must be regulated by the size of the tree — the larger the tree, the greater the distance.

It has been found, experimentally, that trees under eighteen feet in height, and fifteen inches in circumference, advance, taken averagely, as much both in height and circumference, in six years, if the branches are properly shortened, as they do in fifteen years, if these are not shortened, or are improperly pruned. The more trees are pruned close up to the stem before they are eighteen feet high, their growth is proportionally retarded. Trees pruned close to the stem, when the circumference at the part is under fifteen inches, take in damp, so that the tree, if dissected after a certain period at the part where the branches have been cut, will be found black into the pith. This department of pruning, when improperly managed, is the principal cause of rot, more particularly in the larch. The reason is, the wood in young trees is more open in texture than in older ones.

I refer the enquiring reader to my several treatises on thinning and pruning plantations in the *Glasgow Farmer's Register*, 1828, and to the three articles in the *Quarterly Journal of Agriculture*, vol. iii. [here reprinted with Mr. Cree's permission], in which are included the prize essays of the Highland and Agricultural Society of Scotland on the subject of pruning. All with respect to science has been excluded; and to show the advantage of science, I shall make some extracts from the *Edinburgh Literary Journal*, 1830.

“Mr. Cruickshanks furnishes a minute account of all the *practical details* from Sir Henry Steuart's works. He cautiously abstains from any attempt to make his readers acquainted with the *scientific principles*; a developement of which, had he given it, would have rendered these details ten times more interesting to any readers, learned or unlearned. But he could not develop what he did not comprehend; as clearly appears from the whole tenor and complexion of his book. It is the lamentable want of this knowledge which has made Boutcher, Marshall, and Nicol, all meritorious writers, appear unsatisfactory, Hanbury useless, and Pontey ridiculous; and has rendered the pruning system of the last mentioned so ruinous to the woods of England. In a word, it is this want of indispensable scientific information that has kept arboriculture, in all its low branches, down to the low rank of a mechanical art. We should earnestly advise our planters, and our writers on planting, to unite their best efforts in bringing about a new era in this neglected art. They should endeavour at length to learn that a tree is not, as

too many suppose, an inanimate substance, but a living being like themselves; that in its constituent parts it possesses the same chemical principles as they do, though with different properties, and under different laws of organisation."

My system is to shorten the branches till the tree is above 18 feet or greater height, and not less than 15 inches or any greater circumference, before close pruning commences. This system has extended to the royal parks, London, and other parts of England, Germany, and Scotland. Trees which I have pruned may be seen at Sir R. K. Dick's, Bart., Prestonfield, Eagle and Henderson's nurseries, and at the East Prince's Street Gardens, Edinburgh. The Right Hon. Lord Douglas got trees pruned as a specimen. The Hon. Admiral Fleming, from what he had got done, expressed his approbation by stating that my system was the first of the age. The late Lord Advocate, now Lord Murray, on seeing trees that I had pruned for above twenty years, said it would be of national advantage if the system were adopted in the royal forests, and that he would recommend it in the strongest terms to Lord Duncannon. The late Sir Henry Steuart, Bart., after pruning and re-pruning, expressed his approbation in his *Planter's Guide*; and Sir Thomas G. Carmichael, Bart., Sir John Nasmyth, Bart., and Dr. Thackery, M.D., Chester, England, gave complimentary letters, and were pruning above 800 acres on my system: and the late William Elliot Lockhart, Esq., M.P.; W. Scott, Esq., Teviotbank; A. Dickson, Esq., Hasendeanburn; Robert Dick, Esq., Prestonfield; George T. Stoddart Esq., Oliver; Charles Ferrier, Esq., Baddinsgill; W. Lock, Esq., Rachan; David Dickson, Esq., Kilbucho; Adam Sim, Esq., Culter Mains; R. G. Baillie, Esq., Culter; Robert B. Campbell, Esq., Cornhill; George Gillespie, Esq., Biggar Park; Lawrence Brown, Esq., Edmonston; Charles Cunningham, Esq., Newholm; Robert Somerville, Esq., Cormiston; James Wyld, Esq., Springfield; John Wyld, Esq., Westernbank; Alexander Wright, Esq., nurseryman, Edinburgh; Dickson and Sons, do.; Mr. Scott, East Prince's Street Gardens, do.; Mr. J. Reid, do.; Mr. Barnet, do.; Mr. Nicol, do.; Mr. Spalden, Peebles; Mr. Lamb, Selkirk; Mr. Thomson, Lanark; Mr. Robert Brown, forester, Carnwath; and Mr. Andrew Turnbull, forester, Biggar Shiells, have all expressed themselves favourably in regard to my system.

Gavin Cree respectfully intimates to noblemen and gentlemen that he continues to give directions to others, and to prune forest trees on scientific principles. He will likewise give rules, mathematically established, on the thinning of plantations, including planing and draining.

He begs also to refer to Professor Low, in his *Elements of Agriculture* (on Wood), as a proof of his qualifications. In that treatise it is stated that Mr. Cree has brought the system of

pruning to a point of improvement never before known. William Scott, Esq., W.S., Northumberland Street, Convener of the Committee of the Highland and Agricultural Society, who awarded the prizes for the essays on the pruning of forest trees in 1836, expressed his highest satisfaction with the system, workmanship, and direction, at his estate of Teviotbank, in September, 1839. The Rev. Mr. Christison has also noticed the same in the statistical account of Biggar. In the nursery of Eagle and Henderson, Edinburgh, experimental trees may be seen.

*Biggar, February 10. 1840.*

---

ART. V. *On Pruning Forest Trees.* By GAVIN CREE,  
Nurseryman, Biggar.

IN the last number of this Journal [*Quarterly Journal of Agriculture*], I observe an article by Mr. Matthew of Gourdie-Hill, containing remarks on a paper of mine, in the preceding number, on Pruning Forest Trees. That gentleman's avowed object in coming forward is with the laudable design of showing the erroneousness of my system to such of the readers of this Journal as, he says, are incompetent, from want of experience or observation, to judge for themselves. How far he has accomplished this object will be seen in the sequel.

Mr. Matthew gives a pretty correct abridgement of my principles of pruning forest trees, with some slight inadvertencies; in regard to which, however, as these are distinctly enough stated in the article itself, and as they do not particularly bear upon the matters at issue, I need not here waste time by putting him right.

It is contended by Mr. Matthew that pruning will not increase the quantity of timber, and this he couples with his view of all that is necessary to obtain clean timber. "With regard," says he, "to the one half of the timber produced in the temperate zone, the Coniferæ, pruning in any shape whatever will not increase the quantity of timber, either in the single tree, or on a given space of ground. A well regulated closeness, or rather openness, being all that is required for extension; and the sweeping of the smothered branches close down being all that is required for cleanness of timber. In the woods consisting of the other tribes of larger-leaved trees, pruning will also have no influence in increasing the quantity of timber, provided the closeness be properly regulated, and the trees be kept to one leader till they reach the required height of stems." I ask Mr. Matthew how these objects could be accomplished without pruning or cutting off the branches, or parts of branches, in



some manner or other, which, if not pruning, must be held to be very nearly allied to it.

Mr. Matthew then states that my system of pruning "will never ultimately increase the size of the tree, or its measurable timber; but, on the contrary, will greatly retard the extension, and destroy the capacity to attain a large size, and in many kinds will even induce early decay; the lower branches more particularly promoting the enlargement of the roots." This can only take place with his solitary trees, hedgerows, outsides of clumps, and skirts of woods, and from a different cause than that which he assigns. Wherever trees are of the same age, and of a large size, it will be found, that the shorter the stem is, the circumference is the greater; but that does not show that the quantity of timber is greater. For many years after trees have attained their utmost height, they increase in circumference. To exemplify what I state. In 1829, I measured within the area of ten falls, situate at an altitude of 780 ft., ten different kinds of trees, fourteen years after having been planted; and their average height was 18 ft. 9 in.; their clean stem was 3 ft. 8 in.; and their circumference, at 6 in. above the surface, was 14 in. and 3 parts. I also measured four beech trees in the south end of a hedgerow, at the same altitude, planted in 1742 by my grandfather, and the lands have been in the possession of the family ever since, the average height of which trees was 72 ft., the clean trunk 28 ft. 6 in., and the average circumference for timber measure 6 ft. 4 in., which gives 95 cubic feet of timber to each tree. This shows the proportions of the height to the circumference of young and old trees. The young trees are  $18\frac{3}{4}$  ft. in height, to  $14\frac{1}{4}$  in. in circumference; the old trees are 72 ft. in height, to the average circumference, at 4 ft. in height, of 86 in., which shows that young trees exceed in height in feet their circumference in inches; and when of age, the circumference in inches exceeds the height in feet. And further, a tree 10 ft. in length of trunk requires 12 ft. 4 in.; 20 ft. in length. 8 ft. 9 in.; 30 ft. in length, 7 ft. 2 in.; 40 ft. in length, 6 ft. 2 in., in circumference, to contain 95 cubic feet nearly. By a careful inspection of old trees, it will be found, that, in proportion to the height of clean trunk and head, the greater number of cubic feet will the tree contain in the same number of years.

Mr. Matthew's criticism on my article will be pretty well illustrated by the following, amongst others of his paragraphs. "His early pruning," says he, "on the contrary, disposing the remaining branches to push as leaders, to become, in proportion to their diminished number, larger; thus rendering the upper part of the trunk rough timber, and also deterring the root extension, is on a par with the worst of systems." Had Mr. Matthew taken the trouble to read my essay with any attention,

he would have found it distinctly stated, that the remaining branches are all to be shortened, and more especially any large one which is gaining a disproportionate ascendancy over others; and thus this very pretended evil, which he wishes so largely to magnify, was in an especial manner provided against in my system.

Mr. Matthew, in his directions for training plank timber, says: "Cut off, close by the trunk, all shoots which rise at a very acute angle with the main stem; also lop off all branches which, by taking an irregular direction, incline to rub upon the more regular, and remove all splintered, twisted, and diseased branches." By a single glance at this paragraph, it may be seen that he has transformed the principles of orchard-pruning into that of plank timber.

He continues. "After the tree has acquired a sufficient height for plank, say from 20 to 60 feet, according to circumstances of exposure, climate, &c., and also as much branching above this height as may be thought necessary to carry on advantageously the vital functions, as the superior head will now sustain small injury by being thrown out into large branches and plurality of leaders, it will then be proper, in order to have timber as clean as possible, and regularly flexible, to lop clean off all the branches on the stem as far up as this required height; should these be covering the whole or a considerable portion of the stem, as will occur in the more open situations, where the lower branches have gradually become sickly or dead, they ought to be removed by several successive prunings, at intervals of at least two years, that the plant may not suffer any injurious check by losing too many branches at once. From the early attention to procure very numerous feeders, and to prevent any from attaining very large size, the wounds will soon be closed over, leaving no external scar, and as little as possible of internal knot or breaking of the fibre. Should a number of small shoots spring out in consequence of this last pruning, they may be swept down, if good plank be desired. The oak and elm are more disposed to this sprouting out than other kinds."

Now, suppose that proprietors were disposed to follow Mr. Matthew's system, and that they had to commence with the making of young plantations; and suppose further, that they wished only to have clean timber to the height of 40 ft., with a head conformable; it is evident that they must, at the earliest, continue their exertions for nearly half a century, before one tree would be in a state fit for being pruned up for his plank timber. And, from the uncertainty of human life, few, I am afraid, if any, would continue the system so long. I allow that taking out a few branches, even those that rise at an acute angle, is of benefit, and which is in conformity with the old system; and where the

branches are taken off, numbers of small shoots spring out as feeders. But instead of trees having a handsome appearance, as is the case where the branches are only shortened to a proportional length, those trees where the branches are taken out, from whatever cause, always put out numerous feeders; or otherwise have all the appearance of a large bottle-brush, from the small size of branches, and large quantity of them which must be upon the tree. And those to be removed even to the height of 40 ft. of clean stem, at the intervals of two years, must require a considerable work and time, from so many branches intersecting the body of a tree of such a size, and in most instances putting out new shoots for a great number of years, which it will be often found impossible to eradicate.

Although the wounds of trees of the size stated should close over, the trees will always have a rugged and unshapely appearance instead of having a cylindrical form. It requires little inspection of trees generally, to see that below the ordinary-sized branches a hollow is made, in consequence of the descending or proper sap being turned out of its course. Even when the branch is small a hollow will occur, and the parts of the trunk of a large tree that are free of branches, and other parts above the branch, will be found to increase, while the part below the branch remains in a great degree stationary, and a hollow is formed; nay, though the branch should be removed, the hollow will still continue, probably as long as the tree remains.

With regard to naval timber, almost all writers wish to let the world know that if their advice were taken, there would be sufficiency of timber for the British navy of all kinds required, and that the great importance of the whole matter consists in understanding the growing of bent and crooked timber fit for any part of a ship. But this hobby has been long walking on crutches. Sir Robert Seppings long ago recommended the plan of uniting short timbers, which was adopted, by which every kind of compass-formed timber that could be required was obtained from straight timber. The whole frame of a ship can be prepared without waiting as formerly for particular pieces of compass or crooked timber, and every part is now equally seasoned by the new system. All that is required is to raise timber of the best and soundest quality, and of the different kinds; for such is now the state of the science of ship-building and the mechanical arts, that they can do very well without the advice of writers on naval timber.

I might have said much more on the subject of pruning; but as both Mr. Matthew's system and my own are now before the public, I have said as much as the public might feel interested in, and as bears chiefly upon the points at issue. Mr. Matthew

wields the pen with much ease, and will, I apprehend, like a true naval man, as well as a naval timber writer, not easily be overcome. But always playing at long bowls will be of little service to the public. Let us, therefore, at once come to point blank distances, as ships are made to do when well commanded, and show by actual workmanship which of the systems will be of most advantage to the country. Let the trees which have been pruned under my system, and those pruned under Mr. Matthew's system, be examined by a body of men qualified to judge, to be mutually chosen: or, should Mr. Matthew have no trees to show pruned under his system, let us both commence our work of pruning together; and let it be a distinct stipulation in the compact, that whatever decision regarding the respective merits of the systems these individuals may come to, that decision shall be laid before the public.

*Biggar, September 8. 1831.*

---

ART. VI. *On Pruning Forest Trees.* By GAVIN CREE,  
Nurseryman, Biggar

To its woods a country owes much of its beauty; they temper the severity of the climate for the benefit both of the flocks and the crops of the husbandman. But in a no less important point are woods to be viewed, from their economic value. As timber they are extensively, nay, universally, employed in all the mechanical arts; and hence the proprietor of woods has to look to them not only as an interesting, but as a highly valuable, species of property.

Woods are so extensively grown, that there are few landed properties, however small they may be, where they are not to be found to a greater or less extent, either planted by the hand of man, or the spontaneous production of nature. And as it must be obvious that a vast body of people, either as proprietors or as having woods under their charge, must feel an interest in the proper mode of management of this species of property, I trust that you will readily give a place to the following observations on one of the principal subdivisions of this extensive subject—Pruning. That the management of woods is not well understood, or at least but imperfectly attended to, and therefore that the remarks which I am about to state are not uncalled for, may readily be admitted, if we may be allowed to judge from the present state in which a great majority of woods are to be found. I am sure, indeed, that any person of ordinary observation will agree with me in saying that the mode of management bestowed upon woods, in most places, is far behind its sister art, the agricultural operations of the field. But

we ought always to keep in mind, that a mismanaged crop of wood is a very different thing from a mismanaged crop of corn. The latter is only an annual crop; and hence, however much a farmer may feel for the failure of any of his crops through carelessness or mismanagement, the loss is only that of a single season; whereas a mismanaged crop of wood is, comparatively speaking, the loss of the land itself, the crop requiring frequently half a century, and sometimes more, to arrive at maturity. But it is much easier to admit that the evil of mismanagement of our woods does exist, than to explain the reasons of that carelessness or indifference towards this species of property, on the part of those to whom, under proper management, it would become such a source of profit.

The young and rising tree must be modified by art; for, though Nature performs her work unassisted and alone, she is often found to produce irregularities in the growth to maturity of a tree, which are not profitable, nor suited to the uses to which it is employed by man: hence it is for man to modify the tree, so as to suit the purposes required.

Much discrepancy exists in the statements of different authors on the subject of pruning. Pontey, Nicol, Sang, Monteath, and others, as is well known, hold very different opinions on many points connected with it. In such circumstances, those who have the charge of woods, and who may be more guided by the opinions of others than from rules deduced from their own experience, may feel a difficulty in determining the proper system which ought to be adopted. Besides, it is not to be expected that foresters in general, and quiet country gentlemen, should have in their possession the works of many authors on this subject, to enable them to contrast and collate the different modes recommended, and to weigh their merits, or ascertain their correctness, by long-trying experiments. Hence it is that some have implicitly followed one system, until they ultimately found it to be a bad one; others, again, have followed a different system, which they, too, have found to fall far short of their expectations in its beneficial effects; and the result of these attempts, commenced with a disposition to manage well, has often been to neglect their woods altogether. But that this is a state in which trees ought not to be left, is easy to be shown. Trees, when left to themselves, often have a tendency to shoot out into large forked branches, or two or more shoots contend with each other for ascendancy as leaders; and such trees, even at the period of maturation, will frequently be found to present only a quantity of brushwood. Now, it is the province of pruning, under a proper system, to modify and correct these evils; in short, in order to produce a clean and large stem of timber, pruning can rarely be dispensed with.

When opinions on the subject of pruning are in such an unsettled state, I conceive that it may not be deemed an intrusion in me, to present an account of my humble efforts in this department of forest culture. And I may observe, that, whether the rules which I shall lay down shall be adopted generally or not, I have the satisfaction of stating that they are not ingenious speculations or theoretical schemes, but have been derived from observations and my own practice in that system during a period of nearly thirty years; and I may add, that, in whatever light it may be viewed by others, the system has, in all cases which have come under my observation, been crowned with the most satisfactory results. As the system which I shall lay down has an especial reference to the general functions of the plant, and will, I trust, always be found in accordance with the laws of these functions, to make myself understood to those who have not devoted attention to this subject, I find it will be necessary to state shortly so much of vegetable anatomy and physiology as falls within the pale of my subsequent remarks.

In explaining the anatomy of the wood, a transverse section of a young tree near the root will best show the parts to be mentioned. The pith is the part in the centre, which is composed of cellular tissue. Around the pith is the wood, formed of concentric cylinders, agreeing in number near the root with the age of the tree. Exterior to the outmost of these is the bark, which consists of three parts. The first is the outer covering, termed the epidermis; immediately below it is the soft pulpy substance of cellular tissue, or parenchyma. The third is the cortical concentric layers constituting the mass of the bark, the innermost of which is called the liber; and it is between this liber and the last concentric layer of wood that the alburnum is annually deposited.

The functions of vegetables, and in particular with reference to the modes and offices of the ascent and descent of the sap, have excited the scrutiny, and exercised the ingenuity, of physiologists. In this field have appeared Malpighi, Grew, Hales, Hedwig, Du Hamel, Saussure, Senebier, Darwin, Ellis, Keith, Knight, and a host of others. When the earlier of these authors wrote, vegetable anatomy and physiology were, comparatively speaking, little understood; and from the little that was known, or from their own observed facts of isolated cases, the whole structure of vegetable physiology was made up; but a considerable part of it, as was to be expected, consisted of the fanciful theories of these eminent men. Subsequent researches and observations, however, have dispelled the mists from most of these ingenious but fallacious theories, and the science may now be held to rest upon a pretty solid basis, to a part of which I shall briefly advert.

Early in spring, as the temperature of the atmosphere is elevated, the sap ascends in the tree. It is absorbed from the soil by the minute spongelets at the extremities of the capillary rootlets of the root; and it ascends through the root upwards. In very young trees its ascent is through the pith, and also in young branches; but in trees even of a few years old, as well as in old trees, it ascends neither through the bark, nor between the wood and the bark, nor the pith, but through the concentric layers of wood, and, in the greatest quantity, through those last formed.

The bud, which is formed in the preceding summer or autumn, is supposed to be nourished previously to the evolution of the leaf, by nutrient matter in the alburnum deposited in the preceding autumn. After vernalion takes place, and the leaves are all expanded, the sap still continues to rise through the wood, ascends to the branches, and from them to the leaves. The leaf itself is formed of a vascular system of cellular tissue, covered with an epidermis. The sap, when it ascends to the leaf, perspires, or throws off a large quantity of aqueous vapour. It is then acted upon by light and air, in a manner unnecessary to be here explained; and it is at this part of the plant, and stage of the course of the sap, that plants, in the opinion of some philosophers, obtain the peculiar properties, aromatic, narcotic, and the like. After the common sap has been thus changed by the agency of the leaf, it is now called "proper juice"; it accordingly descends in what are called proper vessels, in contradistinction to those in which it rises, and which in trees are commonly situated in the bark. Trees, however, possess the properties of adding their new wood either from the liber or the alburnum, but it is generally deposited between the liber and the alburnum of the last year, which is now being formed into wood. The new vegetable matter thus formed, which was by Grew termed cambium, differs in colour and properties from the proper juice, and is regarded as a secretion, separated from the proper juice by the vascular structure of the liber or alburnum. And it is in this state that it is fit for the formation of vegetable matter, and each year forms the concentric cylinder of new alburnum.

It thus appears that leaves form the primary objects of vegetable functions, and that they form the organs of communication between the wood and the bark, and are the chief cause of the ascent of the sap after they have expanded. The sap, indeed, does ascend, and even in greater quantity, before the leaves have expanded; but this is an effort which the tree is known to possess only for a limited period. And the experiments of Dr. Hales and others made upon plants by divesting them of their leaves, clearly show the important functions which

the leaves perform in the vegetable economy. Now, as branches are the supports or pedestals of leaves, and as the latter are of such vital importance to the proper growth of the tree, and the increase in magnitude of the stem, it is the leading feature in the system of pruning just to be explained to operate upon the branches in such a manner as not to prove injurious, but to accelerate the growth of the tree.

To manage woods in a proper manner, young trees should be examined even the third year after they are planted; and if any more leading shoots than one are found to exist, the best one should be selected, and the others shortened to one half the length of the selected shoot. This practice of examining the trees should be continued every year till they are about 15 ft. in height. These shortenings, however, which should not be confined to superfluous leading shoots, but should include any branch which is gaining a disproportionate ascendancy over other branches of the same year's growth, should, at first, and even for some time previous to this stage of the growth of the plant, be more cautiously done than is necessary to be observed afterwards; and should increase in severity as the tree approaches to, and after it is, 15 ft. in height.

The process of examining a tree is a simple one; it is done in a moment by the pruner casting his eye over the whole tree, and detecting the branches which require to be shortened. And, as a general rule, when it is found that any branch has a greater growth upon it than the leading shoot, it should be shortened by cutting off as much as will reduce it to half the length of the leading shoot, or even less. By this I mean any branch which is either of greater thickness generally, or near its junction with the main stem of the tree, than the leading shoot is at the same distance from its top. And, as trees produce only one regular tier of branches in each year, any branch should be shortened which is of a greater length than the majority of the branches of the same tier; or if the whole are too long, they must be shortened. In the case of trees intended for timber, after they are at and above 15 ft. in height, this rule of shortening the branches must also be applied to the undermost tiers of branches. In this manner, all the under branches of any importance will have been shortened, which prepares them for the next operation.

After the trees are about 15 ft. in height, the undermost tier of branches only should all be cut off close to the stem in one year; in the subsequent year another tier of branches should, in the same manner, be cut off, and so on every year afterwards, always cutting off only a single tier in one year. The same process of shortening the branches is always to be continued, as before directed, but must be discontinued some



years before the cutting off of the branches shall be discontinued, so as to give a more extended top to the tree; for all trees that have naturally conical heads, such as the willow, poplar, larch, silver and spruce fir, require longer heads than those trees that are of a spreading nature, such as the oak, beech, and others. But no branch, wherever it be situated, is to be cut off close to the stem, until such branch stands upon the undermost tier. In this mode of shortening the branches, it will be seen that the tree will at all times present a head of nearly a conical form; and advantage should also be taken of shortening such branches as will balance the tree best, and produce the proper shape of the top. But, in shortening the branches, too much should never be done in one year; nor will it be necessary to do so, provided the trees are attended to in the regular manner I have described.

Many advantages resulting from this mode of shortening the branches may suggest themselves to the careful enquirer. It is well known, that when a part is taken off from the leading shoot of a tree, however small that part may be, the growth of the remaining part of that shoot is greatly impaired, and is never afterwards able to keep pace in growth with the other branches. But the new leading shoot which springs out in consequence of the other having been impaired, and the part of the stem at which it springs out and downwards, will be found to increase in a greater proportion than even lateral branches of greater magnitude than this new leading shoot. It thus appears that the greatest part of the energies of the tree is naturally directed through the main stem chiefly to the leading shoot; and where a tree has two leading shoots or more, these energies are divided amongst them. Or where there are large branches with many subordinate branches upon them, these will also divide the efforts of the growth of the tree, and retain an undue proportion of them. Now, it appears, as has already been observed, that the growth of any particular branch or leading shoot may be greatly debilitated by merely shortening it. Nay, it will even be found, that to cut off the bud of a leading shoot, this purpose will, to a certain extent, be accomplished. But we must ever bear in mind, that any great dismembering of the vegetable structure must operate upon many of its functions, and hence is often found to prove injurious to its growth. Whatever is done, therefore, ought to be done gradually; and this method of shortening the branches, which I have explained, paves the way for their final amputation.

I have endeavoured to explain the important part which the leaves perform in the elaboration of the proper juice. Now, by this mode of shortening the branches, a number of smaller subordinate branches will still be left upon the shortened branch

to produce leaves, and which will perform at least a considerable part of the functions of the branch in its unshortened state. The effect produced on the remaining part of a shortened branch is to produce larger leaves the first year. This may be accounted for from the quantity of sap intended for the entire branch, which will ascend in the first spring, being now applied only to the part remaining. And, besides the neatness and uniformity of foliage which a tree so shortened is found to exhibit, the leaves on these shortened branches will still remain to perform their useful functions. I may add, that, under this mode of pruning, I have found that trees in general will advance in growth as much in one year as they will advance in three or four years under similar circumstances, but when not so pruned.

At that period when the shortening and cutting off of the branches should commence, I have stated the size which the tree ought to be; but it remains to be shown how long the practice ought to be continued, or, in other words, what proportion the head of a tree ought to bear to the pruned trunk. Pontey, Sang, and Monteath conceive that the growth of the stem is as effectually promoted by having few branches to a head as by many. Were this the case, there would be no need of the care and attention of annual shortening and cutting off of the branches, which I have stated to be the principle upon which my system rests; nay, further, it would set aside the established opinions of physiological botanists regarding the properties of the leaves in the elaboration of the proper juice of the plant. Neither, were their assumption correct, would we see those injurious effects result from sweeping prunings, as in many cases practised, by which the trees remain almost stationary in their growth for a number of years afterwards. But that the assumption of these individuals is incorrect, at a very early period of my practice I received experimental conviction. In one instance, I pruned a number of trees in a hedge-row in the common way, but a few of them were pruned much higher, leaving only a small top of branches. The trees were, in other respects, similarly circumstanced as to luxuriance of growth. And those which were most pruned not only at the time did not keep pace in growth with the others, but, even at this distant period, and it is now above twenty years since it took place, these trees are still far inferior to the others. Examples of this kind soon convinced me that extirpating many branches at once, or leaving a small head, was equally ruinous to the proper growth of timber.

I have already stated that the cutting off of the branches should commence when the tree is about 15 ft. in height. The age of the tree at this height will depend upon the luxuriance

or stuntedness of its growth. But, supposing it then to have twelve regular tiers of branches, or to be thirteen years old, it is evident, that, for a number of years to come, by only taking off one tier in a year, the part of the tree covered with branches will be much greater than that part of the trunk which will be cleared of branches. This will be more distinctly shown in the following table. In it the statements are made at intervals of four years, for the sake of brevity; the growth of the tree, too, for the sake of simplicity, is assumed to be the same in each year, namely, 15 in. This, I am well aware, is much less than the annual growth, especially of properly pruned trees; neither, indeed, is the growth constant, but varies with the age of the tree and other circumstances. The assumption, therefore, here made, is taken merely because it is a convenient one for illustrating the effects of this system of pruning.

|  | Height of the Tree. | Total Number of Tiers of Branches. | No. of Tiers of Branches remaining. | No. of Tiers of Branches removed. | Length covered by Branches remaining. | Length of the Part from which the Branches have been removed. |
|--|---------------------|------------------------------------|-------------------------------------|-----------------------------------|---------------------------------------|---|
|  | Feet.               |                                    |                                     |                                   | Feet.                                 | Feet.   |
| At 15 ft. in height, and supposing the tree to have 12 tiers of branches - - | 15                  | 12                                 | 12                                  | —                                 | 15                                    | —   |
| In 4 years afterwards - -  | 20                  | 16                                 | 12                                  | 4                                 | 15                                    | 5   |
| In 4 years more - -  | 25                  | 20                                 | 12                                  | 8                                 | 15                                    | 10  |
| In 4 years more - -  | 30                  | 24                                 | 12                                  | 12                                | 15                                    | 15  |
| In 4 years more - -  | 35                  | 28                                 | 12                                  | 16                                | 15                                    | 20  |
| In 4 years more - -  | 40                  | 32                                 | 12                                  | 20                                | 15                                    | 25  |

In the last line of the table it will be seen that, at thirty-three years of age, at the assumed rate of growth, the tree will be 40 ft. in height; it will have had in all thirty-two tiers of branches, of which twelve are still remaining, and twenty removed; and the height of the part of the stem cleared of branches will be 25 ft., and of the part covered with branches 15 ft. It is a question of some importance, what proportion the trunk ought to bear to the head, or the part covered with branches, in a full-grown tree. Pontey's proportion, as given in the Woburn beech, is 50 ft. of trunk to 22 ft. of head. Sang gives 50 to 25. The proportion which I have found to be the best, is the trunk to be about three fifths of the whole height, and the head two fifths; that is, in a tree of the size in question, 45 ft. of trunk to 30 ft. of head.

The proportion which the head bears to the trunk in the last line of the above table, is 25 ft. of trunk to 15 ft. of head. But, in the example there given, the assumption is, that the tree has then arrived only at 40 ft. in height. Climate, altitude,

situation, and soil operate very materially upon the growth of trees; and these circumstances must be taken into account in assuming the height to which the tree may be expected ultimately to arrive. Where, therefore, it is expected that the tree may arrive at a greater height than that given in the table, and this will, in the majority of cases, be so, the annual pruning should be occasionally omitted, but only for a single year at a time, a considerable period before; so that, at the full growth of the tree, the proportions of the trunk and head may be as stated above.

This is the proportion which the head ought to bear to the trunk in forest trees; but where trees are intended for ornament or shelter, a different mode of pruning will require to be adopted. For ornament, the object in general aimed at is to have large heads, with long pendulous branches. In such circumstances, the tree may be pruned to the height of 5, 6, or more feet, as may suit the taste of the individual. The mode of pruning should be that of annually shortening and cutting off the branches, as recommended for forest trees, until they are at the height required. And to produce the conical form of the branches on the head, if that is wished for, the long branches ought to be shortened; and in those which are of the proper length, but which are not required to be longer, the buds on the extremities of the branches should be cut off. Where shelter alone is wanted, in general the branches should only be shortened; and this will be found in a very material degree to augment the denseness of the branches. By this means, too, trees are enabled to stand closer together without requiring to be thinned, and the under branches also live longer. Trees planted as sheep-stells, as well as in woods and belts of plantations, are, by this mode of shortening the branches, in a great measure prevented from suffering by the destructive effects of heavy falls of snow.

Trees of a considerable size and age, which have been previously neglected, may be greatly improved by the system which I have laid down. But, after the shortenings have been performed, a considerable period should be allowed to elapse before the branches are to be cut off close to the stem. And when this is done, especially in the case of large limbs, too much care and attention cannot be observed. The branches should always be cut off with a saw; and precaution should be taken never to allow the branch to be split off by its own weight, or to injure in any other manner the main stem. Where this may be anticipated, and the branch cannot be propped up during amputation to prevent it, the branch should be removed at two operations: first, by being cut off about 12 or 18 inches from the main stem; and, finally, by being cut off

close to the main stem, but so as not to injure the adjoining bark. This additional trouble will be amply compensated for, by the earlier and superior manner in which the wound will be cicatrised.

Though the remarks which I have made regarding shortening and cutting off the branches are intended to have reference in particular to deciduous and non-resinous trees, I am very far from thinking that resinous trees are not benefited by judicious pruning. The question of the propriety of pruning resinous trees has, I am aware, been very much agitated, and great diversity of opinion has existed, and does exist, on this point. But it must be evident, that, if clean straight timber, free from knots, be wanted, where branches exist, they must be removed, to prevent knots from being formed. Perhaps our best plantations of resinous trees prune themselves; and it has often appeared to me to be an injudicious assortment of trees, to intermix pines with hardwood, unless it be for nurses, to be afterwards removed. Pines, thickly planted by themselves (the Scotch pine, for example), are found to produce the cleanest timber, of the most rapid growth, and frequently without any pruning. But still there are many cases, such as in that of isolated trees, and especially when they are planted along with hardwood, where resinous trees produce large branches. Now these, in the case of the Scotch fir and larch in particular, ought to be removed, provided it can be done judiciously, so as not to injure the growth of the tree. By shortening and cutting off the branches in a careful manner, as recommended for deciduous trees, the object will be attained so as to injure the tree in the least possible degree.

In cutting off the branches of all kinds of trees, I wish it to be distinctly understood, that I mean them to be cut off as close to the stem as possible. But there is a little swell at the junction of the branch with the stem which must not be cut off, by which the wound is not half the size that it would otherwise be. And no wound should be polished up to the circular form of the main stem, as such a process only enlarges the wound, and hence it requires a much longer period before it is healed over. Where the saw is used, the part, and particularly the bark, should be cut clean over.

Authors differ much regarding the mode of cutting off the branches. By some it has been recommended to leave snags in pruning; that is, to leave a few inches between the stem and the part at which the branch is cut off. This I conceive to be a bad system. Even granting that trees suffer much by bleeding, as it is called, especially resinous trees, when cut close to the stem, still that bleeding will soon be prevented by the wound being cicatrised. Now, there are two evils attending the practice of

leaving snags. In the elm, Scotch fir, and many other trees of considerable size, an effort is made by the tree to cover over the snag long before the annual growth of the wood arrives at this magnitude; the consequence of which is, that a large knot in the wood is formed, thus defeating one of the principal objects which it is the province of pruning to accomplish. But another evil consequent upon this practice, where no effort is made by the tree to cover it until the annual increase of the alburnum circles shall have done so, is, that the snag, in resinous trees in particular, is always liable to bleed until it is cicatrised; or, where the snag has lost its vitality, it soon becomes liable to rot. From this latter circumstance, the danger is apparent of often finding large trees when cut down, though apparently sound on the outside, rotted in the interior. Such is frequently the case with snags even in middle-sized trees. When large branches, too, are amputated from old trees, before the growth of the tree can cover the part it has become rotted; and, by exposure to the atmosphere, moisture is carried down the pith of the tree, which commences the work of decomposition, spreading to the adjoining parts of the wood.

Thus, I think, I have shown that the system of leaving snags is a bad one. And I may add that I have pruned, or seen pruned, almost all kinds of trees both with and without snags; but I invariably found that those which were pruned close to the stem healed soonest over, and altogether gave the greatest satisfaction.

Some have recommended not to prune the pine tribe till the branches have become dead. From what I have stated regarding the impropriety of leaving snags, and the danger attending it when there is no vitality in the part, it will at once be inferred, that I recommend all branches to be removed before they are dead. But where dead branches are found to exist on any kind of tree, they cannot be too soon removed; and, for this reason, even fir plantations, which, when thick, are generally self-pruned, would be greatly benefited by the interference of the pruner.

With regard to the proper season for shortening and cutting off the branches, I conceive, that after the fall of the leaf in autumn is the best period for shortening the branches, except the gean, which should be shortened in August or September. I have made many experiments in order to ascertain the proper period for pruning or cutting off the branches. I have performed it in March, May, June, July, and other periods of summer, and in autumn; but I always found that the earlier in spring the pruning was performed, the part was the sooner cicatrised, and the tree did so much the better afterwards. This I found to be the best period for trees in general. But

the sycamore and birch should be pruned in January, the Scotch fir in September or October, and the larch may be divested of its decayed branches at any period when it can be done with a blunt instrument.

From the limits to which this essay is necessarily prescribed, I have been able only to give a rapid, and, I am therefore afraid, a somewhat imperfect outline of my system. To have done complete justice to the subject, a particular account ought to have been given of the manner of pruning trees, under their different modifications, as influenced by climate, soil, situation, and the like; and not only every species, but almost every variety of tree, ought to be brought under particular notice. In a generalised account such as this, therefore, and, indeed, in almost every case of pruning, a certain latitude, exercised in a judicious manner, must be taken by the pruner, so as fully to reap the benefit of the system under any particular situation or circumstance in which the woods may be placed.

To many, and to those in particular who may have paid little attention to their woods, the scheme of management which I have laid down may appear to be attended with too much trouble and expense for them ever to muster courage to attempt following it out. That it is attended both with trouble and expense, I am at once ready to admit; but, for these to be objections of sufficient weight to set this system aside, it would be necessary to show that the trouble and expense are not realised by the superior value of the ultimate crop, a thing which cannot be shown. Let us observe what expense attends the production of many of the farmer's common crops, and, in particular, what additional trouble he must bestow on many of his drilled green crops: but the practice in his case is a common one, and therefore it is not alarming; and, besides, the farmer knows well, that the more care he bestows upon his crops, the surer is he of a better return. Now, the case of woods is quite a parallel one. Where they are improperly managed, or altogether neglected, they will seldom afford a bare return, and often be attended with a sheer loss: whereas, where they are properly managed, they will not only repay the additional expense bestowed upon them, but will, besides, realise to the proprietor a handsome profit.

The history of the mode of pruning which I have endeavoured above briefly to explain can be given in a few words. If I can say that I was indebted to any person or writer, either directly or indirectly, for the idea of my system, it was to the account given by Lord Kames of the manner of pruning hedges, by cutting off only a part of the lateral twigs. And, upon reflection, it appeared to me, that a principle of this kind, in some shape or other, might be beneficially applied to the pruning of

trees. After putting it to the test, however, I found that various modifications upon such a principle, were necessary in the case of trees; and it was from experiments made in a variety of ways, and under different forms, and by carefully marking the results, that I at last arrived at the mode of pruning as above described.

A number of years ago I explained to Sir Henry Steuart of Allanton this system of pruning. At that time I pruned several trees at Allanton; and in two different years since I have pruned and repruned several more trees as examples of the system. The baronet expressed to me at the time a very favourable opinion regarding it, and has since been pleased to publish his sentiments upon it in his *Planter's Guide*. As the paragraph explains the views which I then held regarding the history of the system, I shall here take the liberty of quoting it.

“There is a meritorious nurseryman in this kingdom,” says Sir Henry (*Planter's Guide*, 2d ed., p. 448.), “to whom I was, some time since, indebted for the knowledge of this system, and who has practised it, as he states to me, for nearly thirty years, without having borrowed it from any one. It was first suggested to him, as it appears, by his own reflection, and has since been confirmed by considerable experience, and most uniform success. He was surprised when I informed him that the principle was known, and acted on, in some parts of England, with great effect. This person, who is not less unassuming than he is ingenious, is possessed of valuable materials for a treatise on the subject; by which, besides laying down specific rules for the art, under different circumstances, directions might be given for raising and managing plantations under this system. According to the author's opinion, the pruning should be practised as early as the third year after the plantations are made, and be continued till the eighteenth or twentieth. He has likewise constructed tables, showing the numbers and distances according to which the trees should be planted on an acre of ground, and the comparative results of the ordinary, and of the terminal method. In the present low state of our arboricultural knowledge, I am of opinion, that a present more acceptable than such a treatise could not be made to the British public.”

I was totally ignorant at the time when I explained to Sir Henry Steuart my method, that the system, in any of its forms, was known elsewhere; but, from the conversation which then took place, I was afterwards induced to make research into the matter, to see whether the system which I had formed and adopted was already actually in practice. The only authors that have come under my research, who have treated of shortening the branches, are Mr. Blaikie and Mr. Billington; but neither of them accords in the details with my method. I may remark,



however, that Mr. Billington's work contains many valuable remarks on shortening the branches, and divesting them of the buds at the extremities of branches; and, besides, it is really a work of a practical description, evidently drawn from facts and observations by a practical man. A somewhat similar practice of pruning, by shortening the branches, is, I observe by a paragraph in the last number of this Journal [*Quarterly Journal of Agriculture*], practised in France.

The practice of shortening the branches in pruning has now, it would appear, gained some degree of celebrity. And it has already got a pretty fair share of names, all indicative, more or less, of the nature of the subject; such as "cutting in," "shortening the branches," "terminal pruning," and others, to which I feel disposed to add what I conceive to be the proper name of my system, "concentrate pruning." It seems there has also been some wrangling about the right to claim the invention. Since the bantling has passed the critical months of infancy, and turns out to be a promising child, it bids fair for being legitimated; nay, of obtaining a plurality of paternity, a circumstance not very common in the animal kingdom at least. But it is a thing possible, as has been found in circumstances of a similar nature with the case in question, that bantlings of the same class, and differing only, perhaps, in a few shades of lineament, might be produced nearly at the same time in France, in England, and in Scotland. Granting this to be the case, however, there might still arise a question of some nicety to determine, whether each country may be entitled to claim one for itself, or, if not, which was the first-born one, to claim the legal title of supremacy.

I have not the vanity nor the ambition to aim at a name, as the founder of any particular system; neither does my fort lie in polemical writing. My business in life has been, not to work out elaborate systems by the pen, but to work by manual labour the actual operations of pruning itself; and the system, such as it is, had only been communicated to a few friends, and was long confined chiefly within the circles in which the operations themselves were performed. Of late years, however, my system has become known through a considerable number of the central counties of Scotland; and, in the year 1823, the thanks of the Directors of the Highland Society were conveyed to me for a paper which I transmitted to them on the subject of pruning. But, besides these, were it a point of any importance to be established, I could show trees which have been pruned in the way I have mentioned, regularly, during a period of upwards of fifteen years; though many more than I could at the moment claim have been pruned, on the same principle, for a period of nearly thirty years.

ART. VII. *Copy of a Letter addressed to Sir Charles Gordon, Secretary to the Highland and Agricultural Society of Scotland.*  
By GAVIN CREE.

I OBSERVE a notice of an essay read by John Boswell, Esq., of Balmuto, at the dinner of the Committee of the Highland and Agricultural Society, met at Aberdeen, 1840, recommending the application of science to agricultural improvements more extensively than has hitherto been thought of, which proposal was approved of by Sir F. Mackenzie, Bart., who, at the same time, suggested that a farm should be submitted to the public on which experimentalists might put forth their skill and science, a proposition equally rational as the establishing of experimental gardens or other scientific institutions.

In the improvements of this farm, there is a department, among others, which ought, I think, to be attended to, namely, the scientific cultivation of trees for timber and shelter. The Society may think that they have done enough already for the advancement of this branch of cultivation; but after all that has been done, arboriculture, in my opinion, has never been conducted, to any great extent, with scientific skill.

The abstract from the Society's *Transactions* of 1820, on the management of woods and plantations, only displayed ignorance in the writer of that date on the subject of pruning forest trees. The Society's committee awarded prizes to four different persons for essays on the pruning of forest trees in 1836. The committee who decided the merits of these neither claimed nor expected any reference to vegetable anatomy in illustration of the different systems; in my opinion, an improper neglect, as the system of pruning which is best must be founded on the principles of vegetable physiology. The late Sir Walter Scott, Bart., gave his opinion in the *Quarterly Review*, 1830; and in the *Edinburgh Literary Journal*, 1830, the following remarks occur, attributed to the late Sir H. Steuart, Bart., which glaringly exhibit the inconsistency of those who follow out their methods without any natural principles to direct them. To reason with such men is vain. Their confidence and self-sufficiency are in the ratio of their ignorance; guided by such counsellors, however, they oftentimes succeed in misleading others, and in retarding the advancement of that knowledge that has made Boutcher, Marshall, and Nicol, all meritorious writers, appear unsatisfactory, Hanbury useless, and Pontey ridiculous, and has rendered the pruning system of the last mentioned so ruinous to the woods of England. It is the same want that makes Billington and Cruickshanks,

two of our most practical men, sometimes write nonsense, and Withers always. In a word, it is this want of indispensable scientific information that has kept arboriculture, in all its branches, down to the low rank of a mechanical art. I should earnestly advise our planters and writers on planting to unite their best efforts in bringing about a new era in this neglected art. They should endeavour, at length, to learn that a tree is not, as many suppose, an inanimate substance, but a living being like themselves; that in its constituent parts it possesses the same chemical principles as they do, though with different properties and under different laws of organisation.

Without reviewing the prize essays, it may be stated that both Mr. Grigor's and Mr. Gorrie's are inconsistent in practice, and destructive to the healthy growth of trees.

The proportions of the stem to the top of the trees are more inconsistent than Pontey's; his is 50 ft. to 22 ft., theirs is 50 ft. to 25 ft., and Gorrie's, 50 ft. to 16 ft. 8 in. the top of the tree. The thinning out of the branches in the top of the tree is injudicious in practice. Such pruning close to the stem, when the diameter is not one inch, carries disease into the pith, and in the course of a few years the trees are decayed in the centre, which may be completely avoided by shortening the branches till the trees are about 18 ft. in height, and, when close pruning takes place, about 15 in. in circumference. The system of said essays puts science at complete defiance.

The most consistent system, whether it will be found agreeable to science, will be found in accordance with reason, that all trees should have heads conformable to the length of the trunk, and conical longer than spreading heads; and to show the correctness of my statements, I shall make a few extracts from Professor Lindley's *Introduction to Botany*, 1839, p. 382. "We see in practice the more plants are exposed to light, when growing naturally, the deeper is their green, the more robust their appearance, and the greater the abundance of their odours or resins; and we know that all the products to which these appearances are owing are highly carbonised. On the contrary, the less a plant is exposed to the sun's light, the less its lustre, the fainter its smell, and the less its flavour.

"The fixing of carbon by the action of light contributes in an eminent degree to the quality of timber, a point of no small importance to all countries. It is, in a great degree, to the carbon incorporated with the tissue, either in its own proper form, or as resinous or astringent matter, that the different quality in the timber of the same species of tree is principally owing. Isolated oak trees, fully exposed to the influence of light, form a tougher and a more durable timber than the same species growing in dense

forests ; in the former case, its tissue is solidified by the greater quantity of carbon fixed in the system during its growth."

P. 560. "Mr. Rigg has investigated the connexion between nitrogen and plants. He finds the youngest parts of plants richest in nitrogen. Alburnum he finds to contain more nitrogen than duramen (or heart wood), and fast-growing timber more than slow-growing. He states that his enquiries all tend to prove that nitrogen is evolved during the healthy performance of the functions of plants, and that the atmosphere is the source from which they derive that element. The proportion which it bears to the oxygen given off is influenced by the sun's rays. The difference which he finds in the growth of plants in the shade and sunshine are due in a great measure to the influence of nitrogen."

*Penny Cyclopædia*, vol. ii. p. 121. "Trees crowded together in plantations suffer more from the deficiency of carbonic acid and oxygen, both of which are required for respiration, than deficient nutriment by the roots ; a fact of which proprietors and managers of timber plantations are either not aware, or at least they neglect the practice to which it should lead.

"By the respiration of plants and trees the carbonic acid gas is withdrawn, and an equivalent of oxygen substituted. By the mutual action of the members of the animal and vegetable kingdoms, the balance of the constituent elements of the atmosphere is maintained."

From the extracts above given it is evident that some advantage may be made of science in this neglected art.

I beg the Society's further attention to a few remarks. Mr. Grigor, who received the Society's prize, states that pruning will not ultimately increase the bulk and weight of timber ; whereas Professor Lindley shows that the more succulent or younger parts of plants attract the more nourishment from the atmosphere. In trees pruned by shortening the branches, the whole tree is covered with healthy leaves often three times the size of the adjoining unpruned trees ; by which management growths of feet instead of inches will be made. In trees clothed with a healthy foliage by shortening the branches, the ascending sap is so augmented, both in quality and quantity, that it keeps the trees free of mosses. The same takes place in the animal creation ; when unhealthy they are infested with vermin, &c.

I shall conclude by suggesting to the attention of the Society to follow out the principles inculcated in the remarks and extracts. In the mean time it would be of incalculable advantage, should any member or members place at the disposal of the Society a part of their plantations, containing trees at least six feet in height, to be treated under each system for one, two, or three years.

The sanction of the Highland and Agricultural Society would

render the project of more national importance, and their decision of the merits of the different systems would produce greater benefit than could result from the exertions or patronage of any single individual however high. It is, therefore, of more importance that the Society should bring the trial before the public.

*Biggar, April, 1841.*

---

ART. VIII. *On the Culture of the Gladiolus cardinalis.*

By A. MACKENZIE.

As so very little of the *Gladiolus cardinalis* is to be seen growing in the flower-gardens, or even greenhouses, of this country, I am induced to send you my mode of cultivating this splendid flower. What flower can surpass the brilliancy of the *G. cardinalis* when grown in luxuriance? Here, like the sun in the planetary system, it is the centre of attraction; for, in a space of about 12 ft. by 7 ft., there are no less than 500 trusses of this magnificent flower, exciting the admiration of all visitors. The simplicity of its culture enhances its value. It is generally considered tender; yet it grows here on an elevation of about 900 ft. above the level of the sea, the subsoil naturally cold and wet, in rather a light soil, with little or no protection. For two winters I gave a covering of leaf-mould, about 2 in. deep; but the last two winters they got none whatever, and the result is, that they were never seen growing here in such luxuriance and splendour.

About the beginning of October, when I wish to propagate them, I take from well-established plants a ball or cluster of corms, about  $1\frac{1}{2}$  or 2 feet in circumference, from one side of the strongest plants, and plant them in beds 2 ft. wide, and the plants 1 ft. apart, putting a little sand beneath the bulbs; and in the course of two or three years the beds will be covered with the plants. I plant them about 2 or 3 inches deep. In 1839, I planted a bed in this manner, and with as little care as I would take in planting any herbaceous plant, and have given no protection ever since; yet, in both seasons, namely, 1840 and 1841, the bed has been nearly covered with strong trusses of flowers.

Last spring I separated a large ball of corms, and planted them out singly; and, this summer, only two flowers have made their appearance. I intend to let them remain all winter without any covering. I will give you an account of this experiment in the course of one or two years. My object in planting them out singly is to try how they will prosper when so planted. I would recommend that single bulbs be grown in pots, and protected during winter (especially from damp), until they grow into a cluster of bulbs. When they have attained a sufficient

size, they may be planted out with safety, and will stand the winter.

This plant, when forced, is well adapted for supplying the greenhouse, in the beginning of summer, with its brilliant flowers. In the month of October, I take 8- or 12-sized pots, and fill each with as large a ball of the strongest plants as the pots will admit; protecting them till they are required for forcing. This I do every year, and have from six to twelve trusses of flowers in each pot.

*Blair-Adam Gardens, Aug. 7. 1841.*

ART. IX. *On the Propagation of the Rhododéndron dàuricum, and other Species of the same natural Family, by Cuttings.* By S. O.

A GOOD many years since, the attention of the noble proprietor of one of the finest garden establishments in Scotland was attracted by the beauty of the precocious blossoms of the profuse-flowering *Rhododéndron dàuricum*: a mandate was forthwith transmitted to the gardener, to have the plant increased by all possible means. The fertile mind of this eminent cultivator and excellent man was rich in expedients. The comparatively slow, and, in many instances, uncertain, process of propagation by layers, appeared very unlikely to meet the wishes of his employer; the more expeditious practice of cuttings presented itself, as more likely to answer the desired end.

At the proper season cutting-pots were prepared, and I, as foreman of the plant department, filled them with cuttings, under the directions of my superior; and afterwards watched their progress with a considerable degree of interest. Success was complete beyond expectation; out of several hundred cuttings there was scarcely a failure. The rooted plants remained in the cutting-pots during the winter, and were potted off the following spring; towards the close of the year they were fine healthy plants, the greater part standing 6 in. from the surface of the pots. At that time the idea struck me, that the practice might be extended with advantage to other species of the same and allied genera. Shortly after putting in cuttings of the same plant the second year, I went to take charge of a gentleman's garden in a distant part of the country. Amidst a multiplicity of other pursuits, the propagation of the *Rhododéndron dàuricum* was lost sight of for several years. Leisure returned, and with it the desire to prosecute what I had seen so successfully begun. Cuttings of the *Rhododéndron dàuricum*, *R. dàuricum* *atrovirens*, *R. hirsutum*, *R. ferrugineum*, and a number of the slender-growing azaleas were tried, almost all with the same degree of success. The *R. ferrugineum* takes a longer time to

root than any of the others, but seems equally sure. So convinced am I of the superiority of this mode, in point of time, at least, of extending individual species and varieties, over others usually practised, that I would strongly recommend it to the consideration of nurserymen, and others extensively engaged in the culture of those different plants. It is superior to layers; in so far that ten good plants may, perhaps, be gained by the former method, for one by the latter, and in about one half the time. It is superior to inarching or grafting, unless for particular purposes; in so far that a plant on its own root is always better than a plant growing on the root of another species. It is superior to raising seedlings, even if seeds can be obtained; in so far that stronger plants can be raised from cuttings in one year than by seeds in four: that plants from cuttings are constitutionally inferior to seedlings, is a question yet to be decided by the vegetable physiologist.

I have numberless *Rhododendron* and *Azalea* seedlings of various species, which have scarcely risen from the surface of the pans; at the same time I have plants raised from cuttings of the *R. dâuricum* and *R. dâuricum atrovirens*, little more than twelve months from the parent plant, from 3 in. to 8 in. in height, and with from two to six shoots of various lengths. The pots are quite filled with roots, and the plants may now with safety be planted in the open ground. I beg it to be understood, that reference is only made to the slender-growing species and varieties of both genera. I have never tried the larger-growing kinds, nor yet do I think they could be rooted with equal convenience and facility.

The following is a summary of the practice invariably pursued; and the result was always so satisfactory, that it was never found necessary to change it. About the middle, or towards the latter end of July, the summer shoots of the plants above named begin to ripen; at this time the cuttings must be taken. If taken earlier, they almost always damp; if delayed until the shoots become hard, the process of rooting is extremely slow, if roots are ever protruded. The terminal shoots of the branches are generally rejected, as being too long and unmanageable; the side shoots of about 2 in. in length are preferred. The pots are prepared in the usual manner, as for heath cuttings: that is, they are nearly half-filled with drainage of broken pots, over which is placed a small portion of the fibrous part of peat earth; the remaining part of the pot is half-filled with finely sifted peat, mixed with about one third of white sand; and on the top, sand of finely pounded white freestone, firmly pressed down; the pot is then watered, the cuttings are prepared and inserted about an inch into the sand. The pot is watered a second time, to settle the sand about the cuttings. When the leaves are dry, they are

covered with a bell-glass, and placed in a house with a temperature of from 60° to 70°. The after-management of the cuttings is merely to keep them moist by watering round the outside of the bell-glass, or by introducing the spout of a very small watering-pan amongst the cuttings, so as not to wet their leaves, and to shade them from the direct rays of the sun. The shade ought to be placed over them about nine in the morning, and removed by four in the afternoon. In cloudy days no shade is necessary. I never found it requisite, as in the case of more tender cuttings, to wipe the moisture from the inside of the bell-glass, although I believe it might be beneficial.

The cuttings may be expected to strike in about three months or more, according to the state of the wood at the time when they were put in; but the swelling of the terminal and axillary buds is a sure index to the rooting of the plants. At this period they are to be removed from the heat, and placed on a shelf in the greenhouse; and at the same time air must be admitted, by placing a small piece of broken pot under the edge of the bell-glass, afterwards removing it altogether. In the spring of the following year, when the plants show a disposition to grow, they are to be transplanted into separate pots, and kept in a cold-frame, rather close than otherwise, during the summer. Towards the close of the season, or in the spring of another year, they may be planted in the open ground.

*August 16. 1841.*

---

ART. X. *An Account of some remarkable old Pear Trees at Dunimarle, Culross, Perthshire.* By JASPER WALLACE, Gardener there.

ACCORDING to your request, I send you a short notice of the pear trees in the orchard here. From the accounts given of them I find that they are 240 years old, having been planted in the year 1600. A few of them are 6 ft. in girth at where they branch off, the heads of some covering from four to five falls of ground, and the general height of the trees being from 25 to 30 ft. The situation, as you would have observed when you called here, is close by the sea; so much so, that, when the tide is accompanied with high winds, the spray frequently comes over the wall. In the lower part of the orchard, where the soil is a common black earth, but rather thin and very much intermixed with a hard sort of freestone, the trees are fast going to decay. In the upper part, again, the soil is much deeper, consisting of what is known among gardeners as brown loam; and here the trees are still comparatively healthy, and nearly every alternate year bear a considerable quantity of fruit. The lady who is proprietress of this place wishes to have part of the orchard planted with young trees: now, I am of opinion that they would do no good without the soil being in some manner renewed; and,



as bringing fresh soil from the fields would be rather expensive, how would it do to trench down the turf, and allow it to lie for two years, laying nearly all the soil that would be above the turf up in steep ridges, in the same manner as we do the stiff soil in the kitchen-garden in winter, adding lime and manure at the same time? Having the soil thus exposed both to the winter's frost and the summer's sun, and then turning up the bottom again after the turf had been completely decomposed, would certainly very much invigorate the soil. Perhaps some of your intelligent correspondents will favour me with their opinion on the subject.

*Dunimarle Gardens, Aug. 9. 1841.*

---

ART. XI. *Observations on the Culture of the Gooseberry and Raspberry.* By A. MACKENZIE.

MUCH has been written on the cultivation of that excellent fruit the gooseberry, and also about the prevention and destruction of the caterpillar that infests it, an account of which will be found in many of the horticultural works of the present day. The following remarks are founded on the experience and observation of many years; they may appear simple, but I have no doubt will be found beneficial to many of your readers.

The bushes in this garden are quite healthy, and bear abundant crops, and the fruit for size and flavour can seldom be equalled; while those in the surrounding gardens have been nearly all destroyed for several years back by the caterpillar, though here not one was to be found. My plan is as follows. Having selected a plot or brake or any quantity of ground I think proper for planting gooseberries in, I dung and dig it in the usual way, and plant in rows 6 ft. wide, and 5 ft. between each plant. Afterwards I neither dig, dung, nor manure them in any way whatever, but just hoe and rake during summer to keep them clean. My currants and raspberries I treat in the same manner, and all have the same healthy appearance, and bear abundant crops of large and highly flavoured fruit. By covering with tan or leaf mould, the ground is easily kept clean. The above method saves much labour both in digging and pruning, as the bushes do not produce so much wood.

*Blair-Adam Gardens, Aug. 1841.*

---

ART. XII. *On the Effects of Water on the Growth and Ripening of Melons.* By J. WIGHTON.

IT is a very common practice to plant melons in very strong soil, indeed tenacious clay, and afterwards give little or no water

to them, by which much injury is done; the cohesive soil getting so dry, as to crack and injure the plants by breaking many of their principal roots. The surrounding air being dry also, encourages the red spider; and, before the fruit is ripe, there is often nothing but leafless shoots. What I have just stated may be considered the greatest cause why melons are often badly ripened; and, this being the case, the question is, How comes such a plan to be in common practice? Three reasons may be assigned: 1st, The damp affects the plants; 2d, Moisture tends to burst the fruit before ripe; 3d, Water injures the flavour of the fruit.

With regard to the first, it is a mistaken notion that melon plants do not require plenty of water; indeed, so much so, that it is a question with me, if they would not grow in wet ditches in warm countries; and, if so, it may be asked, How come they to be affected by damp in hotbeds? It ought to be borne in mind, that there is a great difference betwixt plants growing in the open air and those confined under glass, where often the noxious vapours cannot escape. The green-flesh varieties of melons are considered most apt to be affected by damp; and the reason is, they are more hairy than other kinds, and of course retain more wet. Yet, although this be the case, they, like the others, require plenty of water; and there need be no fear of any bad effects from it, provided plenty of air is admitted, to let the exhaling vapours escape from the plants. In dull weather more attention must be paid to this, and less water given.

These remarks also apply to the notion why melons often crack before they ripen, being the second reason given for withholding water from them. The belief that melons burst from too great supplies from the roots is evidently erroneous, because this result in general happens in damp weather; and, although the fruit be almost severed from the plants to check the supplies from the roots, as long as the air holds damp, such severance in no way prevents the cracks from extending. The bursting of all kinds of fruit invariably proceeds from external moisture; let the supplies from the roots be ever so great, the extension of the fruit is proportionate.

In making these remarks I am well aware that much water supplied either way is injurious to fruit when ripening, and this leads to the third cause stated why it is withdrawn from melons at that time. But there is a medium in all things; the plants ought to have sufficient supplies of water to encourage their growth, and also to check that pest, the red spider. It is not unusual to see melon beds, at the time alluded to, like an ash-heap, and the fruit ripening, if it may be so called, on shoots leafless from the ravages of the insect just mentioned. Melons treated in this manner, however good the kinds may be, will

have little or no flavour, perhaps not equal to that of a good turnip.

I may here mention that I have tried various plans, held by some as sure remedies, to destroy the red spider, but found none equal to the old one, namely, plenty of moisture. By the by, some will have the insect in question to be a mite and not a spider at all; this may be, but it will always be more than a mite in a gardener's eye. To his cost, the insect, like the mite, is prolific, but luckily, like a spider, forms a web that retains moisture injurious to the young progeny; otherwise sprinkling would be of little or no avail, and the havoc done by an insect to appearance a mite great indeed.

*Cossey Hall Gardens, near Norwich, June 26. 1841.*

---

ART. XIII. *Notice on Festuca ovina L., Festuca rubra L., and Bròmus praténsis L., as Pasture Plants.* By M. VILMORIN.

AMONGST the things which you must have been interested in seeing here, if you had been able to accomplish what you intended doing, there is one on which I promised you some notes, viz. the cultivation, on a large scale, of certain grasses for pasture and seed. You will have, perhaps, thought that I had forgotten this promise, but that is not the case; I have always had it in view, but being continually occupied in experimental cultivation of various kinds, I do scarcely anything that I wish to do; I hope, therefore, that you will excuse the delay of this communication.

Its object is to recommend three grasses for pasturage, viz. meadow brome-grass (*Bròmus praténsis L.*, *B. eréctus Sinclair*), sheep fescue (*Festuca ovina L.*), and creeping fescue (*Festuca rubra L.*). These are plants of a very inferior quality, if we compare them with the species which constitute the riches of good hay fields: but nothing in nature is absolutely useless; and as pence are more serviceable to the poor than guineas to the rich, these plants, of very little value in the eyes of a farmer of good land, become a treasure to one who cultivates dry and barren soils.

You will recollect, perhaps, that at the time I left you at Fontainebleau, about twelve months ago, to come hither, the drought had for a length of time been parching up several of the midland provinces, and this one in particular. I had heard such lamentations of the want of grass, and the impossibility of feeding the cattle, that I expected to find my farm in the most deplorable state. Fortunately this was not the case, as to the sheep particularly. The day after my arrival, on the first turn I took

in the fields, I fell in with the flock of sheep, and was much astonished to find them in excellent condition, well fed, very lively, with round backs and sides. But where did I find them? In a field of meadow brome-grass and creeping fescue sown in for seed, and which had been reaped a short time before. The shepherd told me that, after the corn had been carried, he had been allowed to put his sheep on these fields; and that this circumstance had saved his flock, which could not pick up a subsistence elsewhere. You would really have been delighted to see each animal following a row, and browsing with avidity the green healthy leaves which carpeted the soil under the stubble, which was cut 2 or 3 inches high. And what would have struck you more is, that these rows of verdure were growing on the side of a calcareous hill, so stony that the ground was scarcely seen among the fragments of rock which covered it. The sheep preferred grazing on that half of the piece of ground that was occupied by the brome. My shepherd told me (what I already knew) that in summer they prefer this grass to the *Festùca*; which they devour eagerly, on the contrary, in winter and early spring.

Some days afterwards I went to visit my neighbour, M. Deprey, proprietor of the farm of Buisson, which I sold to him some years ago. I had formed some years before on the most rocky parts of the estate, which is also all calcareous soil, several pastures of brome and *Festùca*, one particularly of twelve acres, sown with a mixture of the two sorts. I begged of him to preserve these pastures, which he fortunately did. He told me they had been an admirable resource to him; that while all the sheep in the neighbouring farms were dying of hunger, not a single day had passed in summer that his flock did not come home full.

You saw, at Fontainebleau, the *Festùca ovina* used for laying down in grass very poor sandy soil, but which was too cold for it: it has but a poor effect there as turf, and its principal advantage is that of lasting for a number of years. You would have admired it much more on our calcareous rocks, where it forms a much thicker and closer carpet, of a dark green, and which has besides the great merit of being useful, as you have just seen.

Another valuable property of these two plants is their long duration. M. Deprey's pastures have been established twelve or fourteen years; they are still very good and healthy. The largest, which was originally thinly stocked, has increased from year to year by sowing itself; for the sheep do not eat the flower-stalks, but only the leaf of the plant, so that the seed ripens and sows itself again. The first portion of meadow grass which I laid down on the calcareous soil is now eighteen years old; and

it is still good and tolerably healthy, though it has been reaped for seed every year. It is on a soil not 3 in. deep, and has never had any other manure than the stones, which are turned up from time to time by the horse-hoe between the rows, to invigorate it a little, and destroy the weeds which spring up, for they grow freely on this soil, though it is so arid in appearance. There are many bad or indifferent plants among them, such as *Euphòrbia helioscòpia*, *Onopòrdum Acánthium*, *Thỳmus Serpýllum*, *Muscàri comòsum*, &c.; and some good or tolerable, such as *Scabiòsa arvènsis*, *Medicàgo falcàta*, *Coronilla v`aria*, *Anthýllis Vulnerària*, *Achillèa Millefòlium*, &c.\*

On the argillaceous sands of which my property partly consists, these two grasses succeed perfectly well. Ground that I had laid down twenty years ago, and which I have since planted with trees, is still completely matted with green between the rows of trees. When these pastures are thus abandoned for several years the *Festùca* assumes a very melancholy appearance; it becomes a matting of extraordinary thickness, but one composed in a great measure of dried leaves; for in this species the leaves which die naturally remain for a long time on the stalk without decaying, and the plant must be grazed or cut to keep it in a green state. Grown thick and old, as I have just said, it continues to vegetate, but ceases to grow high. These masses of dry and living leaves have often been a very great resource to me as forage, particularly at the end of the winter 1840, when the long continuance of a frosty and drying wind had destroyed almost all the verdure, and suspended the spring vegetation (that of the woad especially excepted). I then had this forage of the old *Festùca* cut, and I found that the cows ate it tolerably well, and that it contributed to their keep during this season of scarcity. I have always thought that, notwithstanding its name, the *Festùca ovina* was more grateful to cows than to sheep; as every time that I pastured them on it, I found that they ate it with remarkable avidity.†

\* The natural flora of these calcareous soils is of extraordinary richness. We find many plants which are never found on our sands, though the two sorts of soil are only separated by a small valley which is often not more than ten paces wide. Another remarkable fact is the variety of plants cultivated which succeed very well on this land, though of species supposed to require the richest soil: thus, Indian corn, colza, Swedish turnip, poppies for oil, flax, and woad (*Isàtis tinctoria*) which I cultivate on a large scale for fodder, succeed very well on the plain; which, though it has greater depth than the rocky soil of which I have just been speaking, is exactly of the same nature.

† It is the same, and in a more remarkable degree, with the *Festùca tenuifolia Sibth.*; which, from a singular mistake, has for a long time been considered and cultivated as the true *ovina*: sheep do not eat it, while cows like it exceedingly. To the kindness of Professor Lindley, I am indebted for being enabled to clear up the confusion that subsisted between these two species.

Meadow brome-grass, also, when it is not renewed by pasturage, becomes mixed with dried leaves; however, it keeps greener than the *Festuca*, and continues to grow high for a much longer time.

Considered as grasses for laying down lawns, these two plants are very inferior in appearance, and in beauty of verdure, to the rye grass (*Lolium pratense*), and other species used for this purpose. The latter grasses ought, therefore, to be preferred in the sort of soil and climate which suits them; but if it is intended to lay down a dry and arid soil, whether calcareous or sandy, the *Festuca* and the brome-grass have a decided advantage, from their long continuance, and the permanence of their verdure during the droughts. In these two respects they are nearly equal, but in others the *Festuca* is inferior to the brome. Its colour, of a deep and dark green, is not pleasing; and, at the same time, its dry and slippery leaf is uncomfortable to walk on. These lawns, however, though generally of a dark dull green, sometimes present remarkable effects and contrasts; and I do not doubt, that, with your taste and talent for judging of and reproducing the beautiful effects of nature, you will be able to make a good use of the *Festuca ovina* in the laying out of a country residence, or of a park scene.

As for the brome, its leaf is flat and soft; its colour, though less lively and fresh than that of rye grass, is, however, a very agreeable green; its shoots extend along the soil like the latter; in fact, it may be said that it is the rye grass of dry soils, and a rye grass that will last twenty years, and perhaps more, if care be taken of it.

But it is more particularly as useful plants that these two species are to be considered; with their help, there is no soil, stone-quarry, or dry sand, which could not be completely laid down in turf, and transformed into a good pasture. Those who have experienced the difficulty of laying down with useful and durable grasses soils of this nature will appreciate the value of plants which so eminently possess this property. We have here a fact which strikes us at first sight; it is, that a single acre of our calcareous land, when covered with these plants, will yield more nourishment to the sheep fed on it, than a very great extent of the same ground left to its natural productions.

The third species, *Festuca rubra*, partakes of the nature of the two others, by its roughness and its long duration. Like the *Festuca ovina*, it grows naturally in our calcareous grounds, but it is not vigorous, and the sheep scarcely eat it. On our argillaceous sands, on the contrary, which are very moist in winter and very dry in summer, it is very luxuriant in its growth, and the sheep eat it readily. One of its peculiar features

is, the facility with which it spreads and covers the ground round it. It has happened two or three times that I have left as pastures fields sown in rows which were beginning to grow old; from the first year that the usual ploughing between the rows was left off, the spaces were filled with plants produced by the shooting from the roots, and the following year the rows were quite invisible (although originally 2 ft. apart), and the whole was formed into a complete mat. When the *Festùca* is thus allowed to mat together completely, it does not grow high. This property, added to its inclination to spread, renders it very fit for forming lawns or pleasure-grounds; the more so, as it is of an agreeable green. The leaf is, however, narrow and long, and grows upright when the plant is vigorous: but these characters are much modified when it grows thick like a carpet, and particularly when it is pastured; I have then seen it make a very pretty sward. The principal disadvantage in making use of it for this purpose would be the expense; for the flower stems are not numerous, and the seed is very subject to be burnt up, which prevents it from being abundant and cheap. It is true that, with patience, in a few years a turf might be obtained very close and good, from a scanty sowing of seed, such as would be too thin at first. The two other species have also their defects; for what being under heaven is without any? Thus, it costs more to sow than rye grass, which proceeds principally from their limited use, which causes the increase of the seed to remain limited in proportion; but, more particularly, they are slow in their growth. When sown on a very dry soil, it is only the second, or even the third, year that the plants have attained their full growth; this will not cause astonishment, if we consider the length of time they last, which compensates for having to wait so long. On good soil the case is not the same, at least, as far as regards *Bròmus praténsis*. I have seen it carpet the soil almost as completely the first year as rye grass would have done.

I have only spoken of these three plants as pasture grasses and turf, uses in which I have been enabled to appreciate their qualities. We may also consider, not the *Festùca ovina*, the stalks of which are too slender, but the creeping fescue and the meadow brome, as plants suited for mowing; the latter particularly is abundant in certain upland meadows, where it constitutes a considerable part of the hay. I will not undertake to characterise them fully in this respect; the ideas I have of their qualities and defects not being sufficiently complete or positive to be presented with any degree of utility.

*Barres, April 22. 1841.*

## REVIEWS.

ART. I. *A Treatise on the Theory and Practice of Landscape-Gardening, adapted to North America; with a View to the Improvement of Country Residences: comprising Historical Notices and General Principles of the Art, Directions for laying out Grounds and arranging Plantations, the Description and Cultivation of Hardy Trees, Decorative Accompaniments to the House and Grounds, the Formation of Pieces of Artificial Water, Flower-Gardens, &c. With Remarks on Rural Architecture.* By A. J. Downing. 8vo, pp. 451, plates, and numerous woodcuts. New York and London, 1841.

(Continued from p. 427.)

“WHERE the *gardenesque* style of imitating nature is to be employed, the trees and herbaceous plants must be separated; and instead of being grouped together as in forest scenery, where two trees, or a tree and a shrub, often appear to spring from the same root, every gardenesque group must consist of trees which do not touch each other, and which only become groups by being as near together as is practicable without touching, and by being apart from large masses, or from single trees, or rows of trees. It is not meant by this, that in the gardenesque, the trees composing a group should all be equally distant from one another; for in that case they would not form a whole, which the word group always implies. On the contrary, though all the trees in a gardenesque group ought to be so far separated from each other as not to touch, yet the degrees of separation may be as different as the designer chooses, provided the idea of a group is never lost sight of.

“In laying out grounds, it is necessary always to bear in mind the difference between the gardenesque and the picturesque, that is, between a plantation made merely for picturesque effect, and another made for gardenesque effect. In planting, thinning, and pruning, in order to produce the latter effect, the beauty of every individual tree and shrub, as a single object, is to be taken into consideration, as well as the beauty of the mass; while in planting, thinning, and pruning for picturesque effect, the beauty of individual trees or shrubs is of little consequence, because no tree or shrub in a picturesque plantation or scene should stand isolated—each should be considered as merely forming part of a group or mass.

“When planted, the trees and shrubs should be scattered over the ground in the most irregular manner, both in their disposition with reference to their immediate effect as plants, and with reference to their future effect as trees and shrubs. In some places trees should prevail, in others shrubs; in some parts the plantation should be thick, in others thin; two or three trees, or a tree and shrub, ought often to be planted together, and this more especially on lawns over which trees and shrubs are to be scattered in the picturesque manner.

“Where, on the contrary, they are to be scattered in the gardenesque manner, every tree and shrub should stand singly; as in the geometrical manner they should stand in regular lines, or in some geometrical figure. In the gardenesque there may be single trees and single shrubs; but there can be no such thing as a single tree in the picturesque. Every tree in the picturesque style of laying out grounds must be grouped with something else, if it should be merely a shrub, a twining plant, a tuft of grass, or other plants at its root. In the gardenesque, the beauty of the isolated tree consists in the manner in which it is grown; in the picturesque, the beauty of a tree or shrub, as of every



other object in the landscape, consists in its fitness to group with other objects. Now, the fitness of one object to group with another evidently does not consist in the perfection of the form of that object, but rather in that imperfection which requires another object to render it complete.'

"In this description of the gardenesque mode of imitating nature, we perceive that the exhibition of a highly developed state of cultivation is the predominant characteristic. The trees and shrubs are grown to the highest possible perfection, and every angle is, as it were, rounded with a species of elegant art. The object is, therefore, mainly to produce highly elegant and polished forms.

"The gardenesque imitation, and what we have termed a simply *beautiful* imitation of nature, may, at first sight, appear to be the same. But there is a strongly marked difference. In an imitation of beautiful and of picturesque nature, the *expression* of the whole scene is the object never to be lost sight of. It is characterised no less by the form of the ground, and by the individual character of the trees themselves, than by the mere arrangement of the trees singly or in groups, and the cultivation to which they are afterwards subjected. Thus, as we shall hereafter point out, the expression of the larch is different from that of the willow, the oak from that of the elm, and so in numerous other trees, both native and exotic. Now, the gardenesque mode of imitation readily admits in the same scenes every species of tree, provided it is planted separately, and afterwards grown in the manner required by that mode, because it depends for its character mainly on the beauty of form as developed by culture. But in beautiful or picturesque imitations of nature, a predominance of such trees and other objects is requisite, as in themselves are intrinsically expressive of either graceful beauty or picturesque beauty. The art of culture, as in thinning, pruning, &c., is directed rather to heighten those peculiar expressions, whether in the single tree or in the group, than to endeavour to produce luxuriance, or the beauty of culture.

"In the imitative scale, viewing the different modes of landscape-gardening as works of art, fac-simile imitations of nature rank the lowest; nature in them being imitated in her own forms and materials, in such a manner as to produce none of the pleasure experienced in the contemplation of art. Next to these we should place imitations in the geometric and in the gardenesque manner, as these depend upon choice materials arranged in regular and systematic, or in elegant and artistical forms, for the admiration which they elicit. And highest in the scale we rank picturesque and beautiful imitations of nature, which join to fine forms, and elegance in arrangement, the higher beauty of sentiment or expression.

"In practice, however, the entire new arrangement, or, in other words, the creation of a landscape-garden on a large scale, will seldom be attempted in this country. In a multitude of examples in the United States, the grounds of places to be improved as country residences have already a considerable degree of natural beauty, in scattered groups and thickets of trees, &c., for the destruction of which no theory of art will apologise. The art of landscape-gardening, in these instances, will be displayed in adding, to the natural beauties already existing, all those graces and elegancies which are its characteristics. Smoothing all harshnesses inconsistent with refined habitation, introducing groups of rare and beautiful trees, shrubs, and plants, and heightening the whole by a polish and keeping corresponding to the style and character of the place and mansion, or the wealth and means of its occupant.

"Besides these beauties of form and expression in the different modes of laying out grounds, there are certain universal and inherent beauties common to all the styles, and indeed to every composition in the fine arts. Of these we shall especially point out those growing out of the principles of UNITY and VARIETY.

"*Unity*, or the *production of a whole*, is a leading principle of the highest importance in every art of taste or design, without which no satisfactory result can be realised. This arises from the fact, that the mind can only attend with

pleasure and satisfaction to one object, or one composite sensation at the same time. If two distinct objects, or classes of objects, present themselves at once to us, we can only attend satisfactorily to one, by withdrawing our attention for the time from the other. Hence the necessity of a reference to this leading principle of unity.

“To illustrate the subject, let us suppose a building, one half of which is constructed of wood, with square windows, and the remaining half of brick or stone, with long and narrow windows. However well such a building may be constructed, or however nicely the different proportions of the edifice may be adjusted, it is evident it can never form a satisfactory whole. The mind can only account for such an absurdity, by supposing it to have been built by two individuals, or at two different times, as there is nothing indicating a unity of mind in its composition.

“In landscape-gardening, violations of the principle of unity are often to be met with, and they are always indicative of the absence of correct taste in art. Looking upon a landscape from the windows of a villa residence, we sometimes see a considerable portion of the view embraced by the eye laid out in natural groups of trees and shrubs, and upon one side, or perhaps in the middle of the same scene, a formal avenue leading directly up to the house. Such a view can never appear as a satisfactory whole, because we experience a confusion of sensations in contemplating it. There is an evident incongruity in bringing two modes of arranging plantations so totally different under the eye at one moment, which distracts, rather than pleases, the mind. In this example, the avenue taken by itself may be a beautiful object, and the groups and connected masses may, in themselves, be elegant, yet the two portions will not form a whole when seen together, because they cannot form a composite idea. For the same reason, there is something displeasing in the introduction of fruit trees among elegant ornamental trees on a lawn, or even in assembling together in the same beds flowering plants and culinary vegetables. One class of vegetation suggesting the useful alone to the mind, and the other only the elegant and ornamental—the two sensations not readily uniting together.

“In the arrangement of a large extent of surface, where a great many objects are necessarily presented to the eye at once, the principle of unity will suggest that there should be some grand or leading features to which the others should be merely subordinate. Thus, in grouping trees, there should be some large and striking masses, to which the others appear to belong, however distant, instead of scattered groups all of the same size. Even in arranging walks, a whole will more readily be recognised, if there are one or two of large size with which the others appear connected as branches, than if they were all equal in breadth, and presented the same appearance to the eye in passing.

“In all works of art which command universal admiration, we discover a unity of conception and composition, a unity of taste and execution. To assemble in a single composition forms which are discordant, and portions dissimilar in plan, can only afford pleasure, for a short time, to tasteless minds or those fond of trifling and puerile conceits. The production of an accordant whole is, on the contrary, capable of affording the most permanent enjoyment to educated minds, every where, and at all periods of time.

“After unity, the principle of *VARIETY* is worthy of consideration, as a fertile source of beauty in landscape-gardening. The former principle might be carried so far by some minds as to produce monotony, as it may be so totally neglected by others, as to lead to compositions only characterised by discordant assemblages of objects. Variety must be considered as belonging more to the details, than to the production of a whole. By producing certain contrasts, it creates in scenery a thousand points of interest, and thus elicits new beauties, by different arrangements and combinations of forms and colours, lights and shades. Variety in plantations may be attained by a combination of qualities opposite in some respects, as in the colour of the foliage, and similar

in others, as the form, which we shall hereafter more fully elucidate. In the views from a dwelling, we produce it by contrasts not so powerful as to be absolutely dissimilar, for this would defeat the purpose, and produce discord; but by retaining the unity of design, and varying partially only the materials employed, as in the case of substituting elegant flowering shrubs and climbers, in the place of trees, or, sometimes, by introducing new elements of beauty, as sculptured vases, sun-dials, fountains, &c. In pleasure-grounds, while the whole should exhibit *unity* of conception and plan, the different scenes presented to the eye, one after the other, should possess sufficient variety in the detail, to keep alive the interest of the spectator, and awaken further curiosity.

“In this brief abstract of the nature of imitation in landscape-gardening, and the kinds of beauty which it is possible to produce by means of the art, we have endeavoured to elucidate its leading principles clearly to the reader. These grand principles we shall here succinctly recapitulate, premising that a familiarity with them is of the very first importance in the successful practice of this elegant art; viz. 1. THE RECOGNITION OF ART, founded on the immutability of the true as well as the beautiful: 2. THE PRODUCTION OF A WHOLE, springing from the necessity in the mind of a unity of sensation: 3. THE IMITATION OF THE BEAUTY OF EXPRESSION, derived from a refined perception of the sentiment of nature: 4. THE PRODUCTION OF VARIETY, including under this term intricacy and harmony, founded on the ever active desire for new objects of interest.

“Neither the professional landscape-gardener nor the amateur can hope for much success in realising the nobler effects of the art, unless he first make himself master of the natural character, or prevailing expression, of the place to be improved. In this nice perception, at a glance, of the natural expression, as well as the capabilities, of a residence, lies the secret of the superior results produced by the improver, who, to use the words of Horace Walpole, ‘is proud of no other art than that of softening nature’s harshness, and copying her graceful touch.’ When we discover the *picturesque* indicated in the grounds of the residence to be treated, let us take advantage of it; and, while all harshness incompatible with scenery near the house is removed, the original expression may, in most cases, be heightened, in all rendered more elegant and appropriate, without lowering it in force or spirit. In like manner, good taste will direct us to embellish scenery expressive of *simple* or *natural beauty*, by the addition of forms, whether in trees, buildings, or other objects, harmonious in character, as well as in colour and outline.”

We have quoted largely from this work, because, in so doing, we think we shall give a just idea of the great merit of the author, instruct our readers without doing him any injury, and give a very favourable idea of the progress of taste among our Transatlantic brethren.

## MISCELLANEOUS INTELLIGENCE.

### ART. I. *General Notices.*

*To destroy Caterpillars.*—A gardener at Glasgow practises a mode of destroying caterpillars, which he discovered by accident. A piece of woollen rag had been blown by the wind into a currant bush, and when taken out was found covered by the leaf-devouring insects. He immediately placed pieces of woollen cloth in every bush in his garden, and found next day that the caterpillars had universally taken to them for shelter. In this way he destroyed many thousands every morning. (*Annual Register*, 1812, p. 46.)

*Wire-Worms.*—The most effectual mode of destruction is that adopted by Mr. Pearce of Pennare Goran, who, in 1838, having had three acres of wheat completely destroyed by the wire-worm, followed with turnips, and finding

his turnips also beginning to fail, he employed several women and children to dig round the affected plants, and collect the worms. In this manner no less than 23,900 were collected, which he paid for at 1*d.* and 1½*d.* per hundred. By this means he saved considerably more than half his turnips, and had an excellent crop of barley afterwards. In an adjoining field a crop of wheat and another of barley were similarly destroyed. From this field he collected 30,000 wire-worms. He calculates that land may thus be freed from the wire-worms at from 5*s.* to 7*s.* per acre. This mode of wire-worm-collecting has long been practised in the best cultivated Kentish hop-grounds. (*Cambridge Chronicle and Journal*, July 31. 1841.)

*Lime in Agriculture.*—A very interesting paper was lately read before the members of the Lyceum of Natural History in New York, by William Patridge, Esq., on the proper application of lime to agricultural purposes. Mr. Patridge maintains that the common practice of burning lime before using it on land is founded in error, and that the limestone ought to be ground instead of burned. Mr. Patridge says that in burning the stone two materials essential to agricultural productiveness are driven off, namely, its water and carbonic gas; and he ascribes to this circumstance the fact, that during the first year the good effects of lime are not observable. He adds that, as the lime returns gradually to its former state of carbonated hydrate, its fertilising properties are evolved. Mr. Patridge adduces some facts which seem strongly to favour his theory. An experimental trial of the plan would be desirable in this country. (*Ibid.*)

---

## ART. II. *Foreign Notices.*

### NORTH AMERICA.

*SWEET and Sour Apple.*—In addition to my notice of such fruit, in the *Gard. Mag.*, vol. vi. p. 596., I can state, on the authority of “the Bay State (Mass.) Democrat Newspaper,” that the editor had received, last autumn, a fine apple from the orchard of Mrs. Byrant, of Marshfield, Massachusetts, one half of which was sweet, and the other sour, and both very juicy and of fine flavour. The flavour of each was distinctly marked, as was also the appearance of the fruit, a ridge running directly over the apple; the sour side is somewhat larger than the sweet, and of a different colour. The editor of one of the newspapers in Trenton, New Jersey, on the Delaware, a few years since, mentioned that a tree bearing sweet and sour apples grew in its vicinity, but did not give the name of the owner—*J. M. Philadelphia*, June 18. 1841.

*To secure good Fruit.*—Two of the best farmers within our knowledge, one resident in Caos county, and the other in Orange county, have communicated to the editor the manner in which they secure good fruit. It is this. They dig at some distance from the body of a favourite tree, until they find a root, which they cut off. The part disjoined is then turned up, so as to appear above ground, and sends forth shoots the first season; and bears in a few years fruit precisely like that upon the parent tree. (*New Hampshire Whig.*)—*J. M. Philadelphia*, March 1841.

*Live Oak.*—Having heard of a very large live oak (*Quercus virens*) upon the Island of St. Simon’s, on the coast of Georgia, I wrote to my ancient friend John Cowper, Esq., P. M., long resident there, to procure its dimensions. They were taken by his son, who is manager of the estate upon which it grows, and are as follows: circumference, at 2 ft. from the ground, 25 ft. 2 in.; at 5 ft., 21 ft.; at 10 ft., 22 ft.: length of trunk to first branch, 10 ft.; circumference of the first branch, 10 ft.; of the second, 12 ft. 5 in.; of the third, 11 ft. 7 in.: height of the tree, 70 ft.

Dimensions of a live oak tree at Cannon’s Point, St. Simon’s, the acorn of which was planted by Mr. Cowper in the year 1803, and transplanted in 1805. Circumference, at 2 ft. from the ground, 8 ft. 4 in.; at 6 ft., 7 ft. 3 in. It then

branches off to ten branches of from 6 in. to 10 in. in diameter. Height from 35 to 40 ft., with a wide round top, and handsomely formed.

I presume you know that our beautiful ships of war, and many of our merchant vessels (the Philadelphia and Liverpool packets for instance), are built of the durable live oak. I spent the winter of 1805 and the following spring on St. Simon's, and saw groves of the live oak, from the lower branches of which hung the *Tillandsia usneoides* waving in the wind, to the length of 15 or 20 feet. Any part of the living plant, according to Mr. Bartram, torn off and caught in the limbs of the tree, will presently take root, grow, and increase in the same perfection as if it had sprung from the seed. When fresh, cattle and deer will eat it in the winter. The acorns of the live oak are pleasant food, and the deer are very fond of them. They fatten on them speedily, and I can speak experimentally of the high flavour of the venison. Mr. Cowper says that the live oak grows quickly in open cultivated ground, but slowly in its native forests.—*J. M. Philadelphia, July 14. 1841.*

---

### ART. III. Domestic Notices.

#### ENGLAND.

*THE Effect of Under-draining.* — There is a field on the estate of the Earl of Leicester, at Longford, in this county, which some years ago was occupied by Mr. John Sherratt, and brought forth rushes in such abundance that the occupier gave leave to any body to carry them away who would be at the trouble to mow them. Three years ago the field was drained, under the direction of Mr. T. Harper of Foston; and this year, we are told, the present occupier, Mr. T. Robinson, has cut three tons an acre of as nice herbage as ever grew. (*Derbyshire Chronicle.*)

*Brugmansia bicolor.* — There is now (Aug.) in the garden of the warden of Wadham College, Oxford, a splendid specimen of this noble shrub. It has been very successfully grown for several years by Mr. Robinson, gardener there, and this season, in the open air, it has attained the height of 8 ft., the branches extending over a surface of 9 ft. in diameter, and presents daily, on an average, about 300 perfect blossoms.—*W. H. B. Aug. 1841.*

#### SCOTLAND.

*The Douglas Monument.* — This mark of European respect for departed genius and worth is now in course of erection by the Messrs. Cochrane, brothers, marble-cutters and sculptors, Perth, who furnished the accepted design to the committee; and we have no doubt the design itself and the execution thereof will do much credit to these gentlemen. The sub-committee appointed to superintend the erection, consisting of Colonel Murray Belshes of Invermay; Mr. Robertson, gardener, Kinfauns Castle; Mr. Dodds, gardener, Scone Palace; and Mr. Gorrie, gardener, Annatt Cottage, met by appointment at the place of erection, in Scone churchyard, for the purpose of depositing, near the foundation, memoranda that may tell to the men of far distant ages of the passing events of the present day. Col. M. Belshes, whose chaste taste, untiring zeal, and sound judgment, have rendered the labours of the other members of the committee comparatively easy, deposited in a cavity made in a stone for the purpose, a paper containing a portrait and biographical notice of the late Mr. David Douglas, furnished by J. C. Loudon, Esq., Bayswater, a copy of the *Gardener's Gazette* of Saturday, the 24th of July, the *Perth Constitutional* of the 28th of July, with other papers and memoranda; and, at the request of the colonel, Mr. Gorrie deposited in the same cavity the gold and silver coins of the present reign; after which the repository was closed, and overlaid with a large stone, whereon is hewn an elegant wreath of foliage, flowers, and fruit, to be surmounted by the marble slab with the

inscription. The ceremony was performed in silence, and in the presence of several ladies and gentlemen, some of whom were acquainted with him whose memory the monument is intended to perpetuate. (*Gard. Gaz.*, Aug. 7.)

---



---

#### ART. IV. *Retrospective Criticism.*

*BURNING of Soils, as a Means of improving them.*—In the Magazine for July, p. 345., there is an article on burning of soils, as a means of improving them; and in your own “Design for laying out a Suburban Residence,” you say (p. 352.) that “the soil of both the kitchen-garden and orchard will be rendered light by burnt lumps of clay intermixed with it in a state of powder.” Sir Humphry Davy tells us that by burning we “convert a matter which was stiff and damp, and in consequence cold, into one powdery, dry, and warm, and much more proper as a bed for vegetable life.” This theory, I think, admits of great doubt of its being founded on strictly scientific principles. At least I have not found it to answer in practice. About fifteen or sixteen years ago the burning of soil in this neighbourhood was all the rage. In fact, there was a perfect mania among the farmers for soil-burning, and, like a great many other new schemes, it was expected to work wonders; but the rage has long passed away, and it is now quite out of date. Farmers found that it did not answer their expectations, and I, as a gardener, found out its bad effects, which is my chief reason for troubling you with this letter. At the time when burning was the rage, my worthy employer wished me to try a quarter of the garden here, which is a stiff tenacious soil upon a clay bottom, stating that there was one of his tenants who had burnt his garden all over, and he had converted it from a strong clay into a fine light soil. This was great encouragement for me to proceed, so I set about it, and had a quarter of the garden burnt all over about eight inches deep. Knowing from the stiffness of the soil that it was of no use half-doing it, I burnt it till it was red like bricks, and expected the most beneficial results. The first summer, which was the fine summer of 1826, it worked light and friable, and I began to think that I had cured it of its stiffness, but even in that dry summer I found it a powerful absorbent. The next summer it began to get stiffer, and the third year it became as stiff or even stiffer than before it was burnt. Whether it was judiciously burnt or not is another matter, but I certainly failed in converting a stiff soil into a permanent light one; nor have I ever since been able to make that quarter of the garden equal to those which were not submitted to the action of heat. I have had it covered with lime and sharp sand mixed, 3 or 4 inches thick, and strongly manured with animal and vegetable manures at different times, but it still continues to bear indifferent crops, and is not so pleasant to work as the rest of the garden. So that I have not only failed in converting a stiff soil into a light one, but I have also deteriorated it, and such has been the case with every one of my neighbours who has attempted it. — *W. H. Mawley Hall, Aug. 9. 1841.*

*Mr. Niven's Stove for various Purposes.* (p. 429.) — I should have been happy, had it been convenient for my friend Catus in the north, to have been honoured with his proper name and address; as, doubtless, from the nature of his *assertions*, the public, for whom he is interested, and I myself, might have derived no small benefit from his superior knowledge. This common advantage being denied me, I must regret leaving him to his present obscurity; from which, when it may please him to emerge, I hope not to be without substantial evidence of the advantage arising from my arrangements. Time is the test of truth. — *N. Niven. Richmond Hill, Monkstown, Dublin, Aug. 10. 1841.*

---

THE  
GARDENER'S MAGAZINE,  
OCTOBER, 1841.

---

---

ORIGINAL COMMUNICATIONS.

ART. I. *The Principles of Gardening physiologically considered.* By  
G. REGEL, Gardener in the Royal Botanic Garden at Berlin.

(Translated from the *Garten Zeitung*, March 14. 1840, p. 81.)

THE treatment of this subject has its particular difficulties. It is not our intention entirely to exhaust it here; it is only an attempt to make the newly acquired discoveries of vegetable physiologists available to practical gardening; to place the general principles of physiology in close connexion with the phenomena daily observed by gardeners themselves, and thus to unite, as it were, their experience into a whole, founded on scientific principles.

Perhaps this paper may give rise to the subject being more comprehensively and fundamentally treated than it is in these pages; nor would my numerous readers perhaps have requested it, had I not enjoyed friendly guidance and help from a quarter which it is not necessary further to particularise.

The subject will be divided into as many sections as there are stages of growth in plants, each of which will form a whole of itself.

I. ON THE PROPAGATION OF PLANTS.

A. *Propagation by Seed, accompanied by the Phenomena of Germination.*

Of all the means of propagation, undoubtedly that by seed is the most important to gardeners; partly because many plants are exclusively confined to that manner of growth, and partly because a more speedy increase is effected thereby.

The seeds of annual plants germinate in general quicker and more certainly than perennial plants, and in general retain their power of germination much longer. The greater part of the seeds of perennial plants, when well kept, also preserve their germinating powers for a long time, while comparatively few decay soon after ripening, as is the case with oily seeds, such as *Dictamnus*, *Magnolia*, *Myristica*, &c. Thus, it has often been remarked, that on places that for twenty or more years have

been used for other purposes, when again brought into cultivation, a great number of annual plants have sprung up: also, in pulling down old buildings, seeds capable of germinating have been found in the clay which was used in building; and even some sorts of grain, which were found in the Egyptian mummies, and must have been several thousand years old, are said to have germinated (??). The seed of *Verónica hederæfolia* L. is the most remarkable in this respect; for, sometimes, after heavy rains, it springs up on the surface of fields, where previously no trace of this plant was to be found, so that it has been supposed that the seed had fallen with the rain. Repeated experiments have, however, shown that these seeds, even in circumstances favourable to their development, have lain for many years without evincing the least change; and we can, therefore, believe with certainty, that in this case they grew out of the ground. Others, again, infer an immediate creation of many of our common annual plants, and advance many circumstances in proof of it; such as their sudden appearance in great quantities, or the continual renewal of the growth of weeds in enclosed gardens, which, for a long series of years, have been always carefully destroyed.

But all this only demonstrates the long-preserved power of germination retained by many seeds. For even if we cannot disprove the immediate creation of a number of plants of the lowest organisation, yet when we reflect how many seeds are disseminated by birds, or by animal manure, this hypothesis, which cannot be admitted in the present state of science, is entirely set aside. At Göttingen, I had myself an opportunity of observing, on several occasions, circumstances of this sort; one year, an annual plant, *Alsine sagittalis* L., came up in great profusion, which had not been found there for more than twenty years. I also found *Rumex maritimus* L., and *Cyperus fuscus* L., thickly overspreading the bottom of a pond that had been drained the year before, no trace of these plants being to be found in the neighbourhood; and what rendered the circumstance the more striking was, that this pond for many years had always been full of water. These cases may easily explain that already mentioned; the more so, as, in turning over the soil, the seed does not always obtain a favourable situation for germinating; and also that the weather, during the period of germination, has a great influence on it.

The most favourable season for the germination of seed is the spring; and though many sorts grow at different times, yet it is always more safe to sow them at this season, when the vegetable kingdom awakens from the sleep of nature. Thus we often find that many of the seeds of our quickly growing annual plants, when sown immediately after ripening, either do not



come up at all that year, or singly and sickly; on which account, even in the open air, there is a distinction between the autumn and the spring seeds. This will be seen by the following experiment. In May, 1838, I gathered, at Bonn, seeds of *Draba præcox*. To be certain of the species, I sowed the seeds in a pot by themselves, which I placed in an open pit (Kasten) with other seeds which were to be kept cold, and treated them the same. Only two plants came up that year, of very stunted growth, and never attained strength to flower; while next spring the remaining seed came up very thick and strong, and flowered in the space of four weeks. Thus it may, in cultivation on a large scale, be observed, that, of the seed which did not germinate in spring, only a little comes up in summer; while late in the season, when plants in the open air make a second growth, more come up; and in the following spring, usually, the remainder of the perfect seed comes up. Of the more difficultly germinating seeds of several trees and shrubs, such as *Méspilus* and others, it often happens that seeds of the same sowing come up every spring after a lapse of three or four years. A great portion of biennial plants make an exception to this rule: their seed, being sown immediately after ripening, generally comes up good and quickly, becoming strong plants before winter, which usually flower the following year. Many, also, that are cultivated as annual plants, show the same sort of development; but it is only those which live for a considerable length of time, such as, for example, a great number of the Californian annuals, which are now cultivated as ornamental plants. In their native country they spring up before winter, and are preserved throughout that season by a continual covering of snow.

Moisture, heat, and oxygen are requisite for the process of germination; and if any of these three requisites is wanting, germination is prevented. Darkness was formerly considered, also, as one of the requisites for hastening germination: but it is not founded on nature; for, though we, in proportion to their size, cover the seeds with sufficient earth to maintain an equal moisture, we also scatter the smaller seeds, such as ferns and heaths, on the surface, and produce the uniform moisture by means of a glass covering.

Moisture and oxygen, together with a small portion of nitrogen (although it is doubtful whether the latter is necessary to germination), are taken up by the seed, while the process of assimilation (or digestion) is promoted by the heat. That the want of moisture prevents the germination of seeds is well known to every gardener; and, on that account, we preserve our seeds in the driest place we can command. The want of oxygen and heat has, also, some effect, as the following will show. If a number of seeds are put in a little water, which

should not exceed more than from ten to twenty times their bulk, and all communication with the surrounding atmosphere be cut off, so that the water may not absorb any oxygen from it, the seeds do not germinate, although placed in a sufficiently high temperature; when the same experiment is repeated with a proportionately larger quantity of water, they find in it sufficient oxygen to enable them to germinate. Old seeds germinate sooner in pure oxygen than in atmospheric air, when oxygen is by degrees absorbed, and carbonic acid given out. As is well known, the absorbed oxygen burns (verbrennt) with the carbon of the plant, and thereby forms the carbonic acid, which is emitted; this may be considered as a sort of breathing process, by which, when, as in this case, it takes place in a high degree, it produces the high temperature which is observable in germinating seeds when many are together. Thus, nature wisely provides that the necessary heat for the process of assimilation of the reserved nourishment should be increased by this property of the seed in germinating.

Under 3° of Reaumur (40° Fahrenheit), the seeds of our native plants do not germinate; while those of the tropics, the functions of which proceed more rapidly, require a proportionately higher temperature. Dry seeds stand so high a degree of cold, that even the lowest temperature of the frigid zone does not injure them. But, if they have imbibed any moisture, they freeze in proportion to the state of growth that had been excited, and according to the climate of their native zone; for cold, as will be shown in another chapter, only kills by the sudden interruption of vegetation or life. Too high a degree of heat is, on the contrary, injurious to seeds; and, when continued for several days, they are killed at a temperature of from 35° to 40° Reaumur (111° to 122° Fahrenheit), while, for a short time, they could stand 60° of Reaumur (167° Fahrenheit), if quite dry. For this reason, we should avoid exposing the seed in seed-rooms to the direct heat of the stove, or drying them on the stove, as they then invariably lose their power of germination.

Plants of the temperate zones, when there is a sufficient quantity of them, are generally sown, in the Botanic Garden, in the open ground, or in shallow pans, which are placed in open pits, where they can be protected from heavy rain, which would wash them up; for the admission of the free air, on account of the great quantity of oxygen it contains, is very favourable to germination. The seeds of the warmer zones, as well as of those annuals which, on account of our short summer, must be sown early in order to ripen their seeds, are put in beds lined with a mixture of half horse-dung and half leaves; because these materials do not become heated to such a degree as

to injure the seed, and, at the same time, produce an equal temperature. When circumstances permit, low houses, with beds prepared for heating, particularly for early sowing, are much to be recommended. If the seeds of tropical plants were treated like those of our climate, they would, no doubt, absorb moisture and oxygen; but, for want of the necessary warmth for promoting the change of matter (or vegetation), instead of the process of assimilation, a fermenting process would take place, which would destroy the seed.

For this reason cold sowing late in autumn is to be avoided, except for seeds difficult of germination. The middle of March will do for beginning to sow the quickly growing sorts, namely, the annuals, in dung-beds; it is, however, better to delay it some time longer, to prevent the plants growing too rank. It must not be neglected to give air from time to time, even to the seed which has not come up, in order that it may have sufficient oxygen for its development.

How much a moderate degree of heat promotes germination, the gardener may almost every day convince himself of; but any one can observe, every year, how the seed sown in the open ground after the first warm spring rains suddenly springs up, if the ground has been sufficiently moist before. But this does not seem to be occasioned by heat alone, as the same effect may be observed in temperate seed-beds, kept regularly warm and moist, when, by removing the sashes, they are exposed to the influence of the atmosphere and a gentle rain. A greater quantity of oxygen seems then to be present in the rain-water and the air, which, penetrating with the rain into the ground, excites the seed to the greatest activity.

The first change which takes place in the germinating seed is seen immediately after the absorption of the water in the cotyledons (or seed leaves), the substance of which becomes softer, often assumes a greenish tint, and tastes sweetish. After this a lengthening of the root takes place, which receives its nourishment from the cotyledons. It then penetrates the husk, through the micropylus (a very small hole in the husk of the seed, which corresponds with the point of the root), and breaks it at this spot, so that the embryo and cotyledons now burst forth. The young plant is then nourished by the aliment laid up in the cotyledons, till the root begins to branch. Hence it often happens, that, when the cotyledons are destroyed by insects or otherwise, the young plants are irretrievably lost.

As soon as the husks become soft and tender, the seeds absorb the surrounding moisture, and germinate in general, if they are not too old, very quickly. If the husk is, on the contrary, hard, and as in many cases stony, the moisture penetrates only through the micropylus, and is communicated to the cotyledons by the

root. In these cases the seeds lie sometimes very long in the ground without germinating; the absorption of moisture going on, in general, too slowly to effect a quick and strong developement, which is absolutely necessary to burst those firm husks or shells which are bound together, as it were, by sutures. These seeds are often lost when they lie for many years; and, to make sure of them, artificial means should be applied. To cause a rapid germination of the seeds of the acacia, soaking them in boiling water has been applied of late years with success; but, in general, this is a very unsafe means, and may do more injury than good. The safest and best way is to cut or file the hard shell, when it is only necessary to penetrate at one spot to the albumen, or cotyledons. From this spot the seed imbibes its quantity of moisture, the root is quickly developed, and, with the help of the swollen cotyledons, bursts the sutures of the husk. In this way I have seen many hard-shelled seeds of monocotyledonous and dicotyledonous plants, such as *Cánna*, *Pæðnia*, *Acàcia*, *A'brus*, *Erythrina*, *Cássia*, *Schòtia*, *Guilandina*, *Adenanthèra*, *Bauhínia*, and *Cæsalpínia*, germinate in a short time, mostly in from ten to twenty days. If the seeds are old, they should, after cutting, be laid for a few days in lukewarm rain-water, and, if they have any life remaining, it will be stimulated thereby.

Something similar also takes place with seeds which, besides the testa, or husk, are also enclosed in a pericarpium, or fruit-covering. They lie either in fours, at the bottom of a dry hollow cup, as in the *Labiàtæ* and *Boragíneæ*; or they are single, or several, surrounded with a thick fleshy cup, as in many species of the *Rosàcææ*; or single, or in twos, covered with a dry cup, which, in general, grows into the pericarpium, as in *Compòsitæ*, *Umbellíferæ*, and their allied species. Lastly, in the *Gramíneæ*, we find them only surrounded with the pericarpium, as true caryopsi, which often grow into the husky skin of the perianthemum or involucellum. Many of them germinate as easily as naked seeds; and this depends, also, partly on the capacity or incapacity of the husk to absorb water in a natural state. We find them hard and stony only among the *Rosàcææ*, as *Ròsa*, *Prúnus*, *Cotoneáster*, *Méspilus*, *Cratægus*, &c., which also require cutting if intended to germinate quickly. The remainder are divided, according to their formation, into two groups; those possessing albumen, in which the embryo lies, and those that do not. For, as we remarked that the cotyledons always imbibe the water first and easiest, whereas the albumen is less hygroscopic, the germination of those seeds which have none, but whose interior is entirely filled with the embryo and cotyledons, as in the *Boragíneæ*, *Labiàtæ*, *Compòsitæ*, &c., will be more easily effected.

The *Gramíneæ* and *Umbellíferæ*, on the contrary, possess

albumen : in the former, the embryo lies outside of the albumen, on which account they easily germinate; whereas, in the latter, the embryo is entirely surrounded by the albumen, for which reason, with the exception of most of the annual or biennial sorts, they are more difficult to vegetate. As they cannot be cut with advantage, it is usual to sow them late in autumn, with other difficult-growing sorts; so that when the universal period of germination comes, in the spring, they may be sufficiently penetrated with moisture. This method is very well suited for sowing on a large scale; but as the seed often perishes during the winter, and the earth becomes sour, or thickly covered with moss, the preferable way for valuable seeds is to sow them in the spring, after they have been soaked for some days previously in warm water.

In this way very old seeds of *Umbelliferae*, in which the embryo seemed entirely dried up, often germinate quickly, of which I give the following as an example:—In the botanic garden at Bonn, in the spring of 1838, four pans were sown with seed, full ten years old, of *Férula tingitana* L., and only those in two of the pans were previously soaked. The latter sprung up all together in from ten to twenty days, while of those in the other pans, which were left for trial, only a few plants came up in one pan in the spring of the following year, the rest of the seed having all rotted.

The process of germination transforms the nourishing matter contained in the seeds, such as starch (*amylum*) and gluten, into a sugary substance. Kirchhof's experiments show that when starch is stirred with a little cold water, and then boiling water poured on and continually stirred till it forms a consistent mass, such as is used in book-binding; and, after some gluten (*gluey matter of plants* (*Pflanzenleim*) and albumen) has been added, the whole placed in a tolerably warm temperature for several days; the mass by degrees becomes watery and sweet, and part of the starch is changed into gum, and part into sugar. The same effect is produced by boiling the mass with diluted acid, and putting it in a temperature of from 10° to 18° R. (56° to 59° Fah.), with or without the influence of the open air. In the latter process, a mass indissoluble in water remains behind, which has been named lignine, starchy woody matter (*stärkeartigen Holzstoff*). From these experiments it appears that it is chiefly heat, and the gluten contained in a great many seeds, which cause the transformation of the matter in germination, which we call the process of assimilation.

There are still many experiments which have been made to accelerate germination open to the consideration of the practical gardener. Alexander von Humboldt was the first to observe that watering with chlorine (*Chlorwasser*) induced speedy ger-

mination, which proved that chlorine generates oxygen in the light. The same effect has also been observed in seeds which vegetated entirely in the dark; and as, according to the observations of Göppert, iodine and bromine (Jod und Brom), in conjunction with hydrogen, produce a similar effect, it appears that both these matters, as well as the acids frequently applied for that purpose, hasten the process of assimilation. It cannot be denied, that all these substances accelerate germination, but to the practical gardener they must be considered as experiments unfit for general practice; for the young plants thus called into existence grow sickly through the excitement, and die off, which cannot surprise us, as the same effect is seen when plants of cold climates are reared too warmly, and are not placed in a cooler situation after germination.

In the seeds of the species of *Casuarina*, *Sálvia*, *Collòmia*, and *Lepídium*, we find a remarkable formation, which deserves to be mentioned at the conclusion of this chapter. In the outer cells of the seeds of these plants there is a sort of slime, which, when they are kept moist, attracts the water, swells out, bursts the testa, and surrounds the seed as a slimy sticky mass, which appears to be intended to keep the seed continually moist, and to nourish the young plants in the first stage of their growth.

(*To be continued.*)

---

ART. II. *Effects of the Winter, from December 1840 to March 1841, on perennial Plants in the open Air.* By FREDERICK OTTO. Berlin.

(Translated from the *Garten Zeitung* for 1841, p. 195.)

ALTHOUGH last winter was not generally so severe as that of 1837-38, its effects on vegetation here were very different, and caused the most melancholy desolation among our plants. The perennial plants suffered the most, although our trees and shrubs were not spared. No winter here ever had so great an effect upon the perennials; and many of them, which had formerly withstood the most severe cold, are this year completely destroyed. The cause of all this devastation is undoubtedly the absence of a covering of snow, as we had none whatever in the beginning of winter, and the frost therefore had no difficulty in penetrating the soil; which, upon trial in different places, was found to be the case, as measurement proved it to be nearly 3 ft. deep. The soil by this means could not be worked, and the usual winter occupations were put a stop to. In addition to this cold, a sharp and continued east wind set in, with a great deal of sun-

shine, which, if it wanted in power, produced a dry air; and thus the frozen stems above ground, and those of the perennials under ground, sustained still more injury, and at last were completely destroyed.

The cold began about the beginning of December, and lasted, without being very severe, till the middle of January; but it was uninterrupted and dry, and without snow. At last some snow fell, which formed a covering; but it was unfortunately too late, as the greater number of the perennials had already yielded to the effects of the winter, and others, again, that had withstood it, shared the same fate, notwithstanding the fall of snow. A thaw then came on, which lasted but a short time; the snow was melted, but the water could not penetrate the frozen soil, and remained standing on the beds, when the frost again came on, and lasted till March, so that the beds became sheets of ice, which totally covered or surrounded the plants. This was followed by milder weather, and the ice began to give way about the plants; but the frost set in again, so that the plants were again surrounded by ice, and many of them completely penetrated by it. The effects of last winter have proved, that  $18^{\circ}$  or  $20^{\circ}$  of Réaumur, accompanied by a sufficient covering of snow, is by far less injurious to vegetation than a much less degree of cold without snow, particularly in a free open situation, where the soil is light and sandy. In the northern regions, where the winter regularly sets in at a fixed time, with a heavy fall of snow, and where the weather is steady, accompanied by a great degree of cold, and the thaw does not come on till spring, there the perennials thrive much better, and fewer of them perish from the frost than in those parts where the weather in winter is variable.

Nature often acts differently from our theories; and it is remarkable, that the frost destroyed those plants which we had always considered very hardy, and which had stood our climate for many years, some of them, indeed, actually natives, and only retained in the garden as fine specimens. Among these may be reckoned, more particularly, perennials, which for a course of years had been the ornament of our gardens, but which were entirely swept away, from the effects of the winter. Auriculas, also, primulas, daisies, pinks, mallows, violets (even those in a wild state), and a great many similar plants, were entirely destroyed. Strawberries were partly frozen, particularly where the runners were not taken away in autumn. The evergreen perennials, however, suffered the most, such as the different species of *Saxifraga*; the leaves of which were so hard frozen that they might have been reduced to powder, especially where they had no covering, or where the covering had been blown off by the uninterrupted east wind. The following plants, also, were totally killed by the frost:

a great part of the *Labiâtæ*, *Scrophulárinæ*, *Boragíneæ*, *Asclepiádeæ*, *Convolvulàceæ*, *Polemoniàceæ*; the greater number of the species of *Phlòx*, with their varieties; several of the *Umbellíferæ*, *Leguminòsæ*, *Malvæceæ*, *Caryophýlleæ*, *Crucíferæ*, particularly the evergreen species, and a great many of the North American *Compósitæ*, such as those of the genera *Aster*, *Solidàgo*, *Eupatòrium*, *Rudbéckia*, &c.; and even, also, the Syngenesious natives of the North of Germany, such as *Círsium*, *Cárduus*, and *Centaurèa*, have suffered severely. Plants which have stood the winter here for fourteen years in the open air, such as *Cássia marilandica*, *Maclèaya* (*Boccònia*) *cordàta*, and *Rhèum palmàtum*, &c., are completely killed by the frost. Among the bulbs, the species of *Lílium* have principally suffered; also *Írìdeæ*, and the *Babiàna plicàta*, in great numbers, have perished. It would occupy too much space to enumerate all the species of plants that have suffered more or less from the cold, but those I have mentioned are sufficient to show that exactly those have suffered the most which we had been in the habit of considering as hardy.

On the other hand, many plants escaped the frost, which, in other winters that were less severe, had always shown themselves tender, and among these many specimens which had been planted to replace those which had been previously killed by the frost, and therefore more likely to suffer. There remained uninjured, for instance, under a slight covering, different species of *Pentstèmon*, *Nuttállia digitàta* and *malvæfòlia*; *Epimèdium violàceum*, *Masschiànnum*, and *macrànthum*, from Japan; the different species of Japanese *Fúnkia* (*Hemerocàllis*), *Hoteía japónica*, *Michaúxia campanulòides* and *lævigàta*; also many plants from Nepal and the Himalayan range.

The biennials have also particularly suffered, as their tender roots could not withstand the cold; and among these the *Crucíferæ* and many others have perished, which had stood the cold of harder winters. As far as we are informed, the winter corn has particularly suffered in many places, and particularly about the banks of the Oder.

Among the trees and shrubs, the *Leguminòsæ* have suffered the most; such as *Genísta*, *Cýtìsus*, *Adenocárpus*, *Coronílla*, *Cércis*, &c.; also the *Rosæceæ*, such as *Ròsa*, *Rùbus*, *Anýgdalus*, *Cérasus*, *Cratægus*, *Photínia*, *Cotoneáster*, *Pýrus*, and *Cydònia*; while, on the contrary, the different species of *Spiræa* from Nepal, such as *S. vacciniifòlia* and *bélla*, remained uninjured even to the very points of the shoots. Plants of *Calycánthus*, of thirty years of age, were completely killed; the like of which never occurred before. *Pæònia Mòltan* also perished.

In many private gardens where shrubs, and particularly roses,



had been buried \*, to protect them from the cold, they perished because the place dug had not been deep enough.

Plants in greenhouses, on the contrary, stood extremely well, on account of the clear and frosty weather. The plants, also, in hot-frames, which are not kept covered longer than two months, were fresh and healthy; most of them were evergreen shrubs, and plants which partly belonged to the frigidarium and partly to the tepidarium.

---

ART. III. *Importance to Gardeners of a Knowledge of the Method of analysing Soils.* By PETER MACKENZIE.

THE method of analysing soils should form a part of the acquirements of every gardener, and yet how few there are that can tell what are the component parts of the soil from which they earn their daily bread; judging from their writings, they appear to be better acquainted with synthesis than analysis.

Almost every gardener has his own composition for growing his favourite flowers and vegetables. Take, for instance, the carnation. One man recommends rotten horse-dung, loamy earth, and coarse sea-sand, in certain proportions; another will substitute cow-dung for horse-dung; a third will add newly slaked lime; a fourth recommends unburnt sulphate of lime, finely ground; and a fifth considers burnt turf ashes an excellent ingredient for mixing with carnation composition. The most of them agree in recommending loamy earth as part of their compost: but loam is a very indefinite term; sometimes clay may predominate in one place and sand in another. It is also known to those who have analysed soils, that the oxide of iron is not always found in equal quantities; and there may at one time be the peroxide of iron, and at another time the protoxide of iron. Yet, with all these differences, and more that might be named, it still goes by the name of loamy earth. However well some of these composts may do in one part of the country, it is as well known that they are often condemned in another district. If both loams had been analysed, perhaps some ingredient would be found in the one which the other did not possess, that might be the cause of the failure so often complained of.

If gardeners were able to discover by analysis the component parts of the soil, it would enable them, perhaps, to work with a greater degree of certainty than they can possibly do at present, with their empirical knowledge in that department of gardening.

\* [In this operation the plants are not taken up by the roots, but a hole is dug, and the plant is bent down in it, and then covered up.]

The druggist may be a very useful man in his own way, and may be well acquainted with the pharmacopœias of London and Edinburgh; but many will not trust their bodies in his hands where medical aid is required: it is generally from the prescription of the physician that he compounds his medicine; and although he may have an abundance of Emplastra, Pilulæ, Pulveres, Tincturæ, and Trochisci, yet even these are often made by order of men who have made, or ought to have made, the *Materia Medica* their study; who can tell whether a narcotic drug will act as a stimulant or not; or whether ipecacuanha is an emetic; or if *Arum maculatum* will increase the secretion of saliva. Now, as gardeners have to act, in the case of plants, both as physicians and pharmacopolists, they certainly should endeavour to become acquainted with the ingredients of the soil, and what effect these may have upon vegetation. Besides the water of absorption, there are often found in the soil stones and gravel, undecomposed vegetable fibre, carbonate of lime, carbonate of magnesia, silica, alumina, oxide of iron, salt, sulphate of lime, copper, &c. Some of these ingredients appear to be mechanically mixed, others to be chemically combined; and no doubt particles of matter in both states will exert an influence upon the growth of vegetables that may either be beneficial or pernicious. It is, therefore, the gardener's interest to become acquainted with the good, and be able to detect the evil, properties that may exist in the soil.

*West Plean, Sept. 4. 1841.*

---

ART. IV. *On the Use of the Species of Pisang (Musa paradisiaca) and the Banana (Musa sapiéntum).* By EDWARD OTTO.

(Translated from the *Garten Zeitung* for 1841, p. 185.)

Two species of *Musa*, with their numerous varieties, constitute the chief articles of food of the natives and slaves on the Island of Cuba; and it is also somewhat the case in South America, but has not long been so common there. Two species are distinguished in both countries:—

1. *Musa paradisiaca* L. Pisang; Platano, *Spanish*; Plantain, *English*.
2. *Musa sapiéntum* L. Banane; Cambure, *Spanish*; Banana, *English*.

1. *Musa paradisiaca*.—This came originally from India, and is also said to be indigenous to the Brazils, as I found it in several parts of Venezuela, where it was not likely it could have been planted. I met with it in places which bore no traces of an old plantation, and where no vestiges of the settlement of human beings could be seen. It may, indeed, have been culti-

vated a hundred years ago by the Indians, whose custom it is to leave their places of abode after the lapse of a few years, if they find that the cultivated soil begins to yield but little increase. A hut constructed of the fronds and branches of palms, and a small spot of cultivated land in a wild luxuriant neighbourhood, so soon show the effects of time, that, even in the course of a few years, no traces of either are visible, except, perhaps, a few plants that have been cultivated there may continue to grow. I saw but few, and none that bore any signs of blossom or fruit.

*Musa paradisiaca* is the species that is most cultivated and most used. It grows to the height of 12, 15, or even 20 feet, according to the soil and situation. The stem is 1 ft. to 1½ ft. in diameter, of a light yellow green with dark brown spots, and the petiole of the leaf is of the same colour. The fruit 1 ft. to 16 in. long, and 2 or 3 inches broad. Its outer covering, when ripe, is of a deep yellow, and, when too much so, has dark brown spots. The fleshy part is also of a dark yellow colour. The fruit is used in various ways, and, as I have already said, is the most cultivated. It is a substitute for bread for the slaves, and poor white people, in almost all the West Indian Islands, who have neither the means nor the wish to prepare bread from the maize (arepas). A slave can have from six to eight fully grown unripe fruits, from the largest and best plants, which he can prepare in any way he pleases; and an idea may easily be formed of the number of pisangs that are cultivated, so as to supply from 400 to 500 negroes on an average with five pisangs, large or small, daily, not to mention the amazing quantity that is conveyed to market in the different towns. As far as I have observed on my journey, this fruit is more eaten on the islands than in South America, where the cassava is used instead, the well known bread made from the roots of the *Jatropha Manihot*.

This species of *Musa* is but little eaten when raw or fully ripe; partly on account of economy, and partly from the taste being not quite so agreeable as that of other varieties. It is, however, eaten when well covered with sugar or syrup. When half-ripe, the outer covering is removed, the fruit pressed flat, and roasted or fried in fat; and it is also cut in thin slices, either horizontally or longitudinally, and prepared in the same manner; in both of which ways it has a most agreeable taste. When the fruit is fully grown, and begins to change colour, it is roasted on coals, without removing the outer covering; and in this state it is used as a substitute for bread. It is floury and dry, and very much resembles potatoes in taste, particularly when eaten with fresh butter, very rarely to be met with in those countries. When unripe, half or fully grown, it is boiled in meat soup,

with vegetables, as we do carrots and turnips, &c. The flesh of the fruit remains pretty firm, but has a good taste, and gives the soup a greyish colour.

There are a great many varieties of this species which I have particularly examined.

a. *Musa paradisiaca* var. *domínica*. *Dominique*. — Introduced from the Island of St. Domingo. A platane, or pisang, with a stem 10 ft. in height, and frequently higher; and spotted with black and brownish-red spots, and the petiole of the leaf the same. The fruit is small, never more than half a foot long, and 1 in. thick; the outer covering of a pale yellow colour, and the flesh darker, always a little tough, but of a very good and aromatic taste, and quite uninjurious when eaten. This species is usually eaten when ripe, and only when the other species cannot be obtained. They boil or fry it in the same manner; and, as the fruit is smaller, it is more rarely to be met with, and not so much cultivated.

b. *Musa paradisiaca* var. — Another variety, called topocho by the Indians, and not very different from the foregoing. The stem, however, is smaller, 6 or 7 feet in height, and the leaves are of a deeper red, and ash grey-coloured underneath. The fruit resembles the former exactly in size and taste, and is borne in much the same quantity.

2. *Musa sapiéntum*. *Banane*; *Cambure*. — This species is very different from the first mentioned, and is much less cultivated, as its fruit is generally eaten ripe, or in a raw state, and more on account of its agreeable flavour than as an article of food. In some parts of South America, however, I found it very much cultivated, and it was the favourite fruit of the Indians; and, when there is a scarcity of pisang, this species of *Musa* supplies its place. The stem is 10 or 12 feet in height, and is green, marked with red. The fruit is small, being only 3 in. long, and 2 in. broad. Some of the varieties are much smaller, and of an oval form; but the flavour of these is considered the best. The flesh and outward covering is of a pale yellow. This species is generally eaten, when ripe, in an uncooked state; but it is sometimes eaten with sugar, like pisang. The soup in which it is boiled assumes a brownish violet colour.

There are several varieties of this species, such as —

*Musa sapiéntum* coloràda (*ròsea*). *Red Banana*. — This is undoubtedly one of the prettiest musas. The stem is from 12 ft. to 15 ft. in height, the leaves long and slender, and the colour of the stem and petiole of the leaf of a reddish brown. The fruit is 1 ft. long, and 2 or 3 inches thick, rounded at the ends. The outward covering is reddish brown; the flesh a pale yellow, very soft, juicy, and aromatic. It is only eaten when ripe, and in an uncooked state.

Another, with somewhat reddish leaves, and the fruit also reddish, very much resembles the former, but is very seldom met with. I consider it to be *Musa sapientum rubra*.

The pisang and the bananas, when cooked, are quite uninjurious; but, when raw, they are not very wholesome; and this is particularly the case with the bananas. They are extremely cold on the stomach, and difficult to digest. It is very dangerous to drink even water after eating them, and spirituous liquors are much more so, as the most alarming consequences may be expected to follow. The pisang is very nourishing, but has the tendency of enlarging the stomach, particularly with children.

The cultivation of the *Musa* in tropical countries is very simple, and almost without any rule whatever. It is planted, when quite young, in coffee plantations, and generally between the coffee plants, to which they form a shade; and they are planted from 15 ft. to 20 ft. apart. After the fruit has been gathered, the stem is cut down, and permitted to lie among the coffee plants, where it soon decays, and serves as an article of manure. It is propagated with ease and rapidity by shoots from the root. A coffee plantation, when deserted altogether or neglected, soon becomes transformed into an impenetrable pisang forest, as the latter in due time chokes up the little coffee trees, which soon begin to look ill and die. The *Musa* requires a light but nourishing soil, and one that is rather moist than dry, and very much exposed to the sun. Its size and strength depend entirely on these circumstances. A plantation of pisang has never a very inviting appearance, as the greater number of the leaves are generally very much torn by the winds, and hang down on the stems either in a half-green or withered state. The above-named varieties bear plentifully, and each stem forms a spike which produces from 60 to 400 or more fruits. They may be cut off when not perfectly ripened, and hung up, when they generally come to maturity all at once. When I was in the valley of Aragua, in Venezuela, I saw a very remarkable occurrence in the coffee plantation of Palmar: a stem of a *Musa paradisiaca* had a large spike of fruit, the upper part of which was *M. paradisiaca*, and the lower part *M. sapientum*. The lowest blossoms were probably fructified by insects conveying to them the pollen of *M. sapientum*. Varieties between these two, with respect to the fruit, are not known, and I have never found fully formed seed in any.

Besides the stem of the *Musa* being used as an article of manure, the leaves are also in great request as a covering for huts, and as an umbrella for the coffee when it is being dried, and for packing all kinds of objects. The leaves are very much used as a cooling remedy for wounds and swellings from burns or irritation, and they are, therefore, laid under the saddle on

horses and beasts of burthen. Pork, onions, Spanish pepper, and similar spices, when mixed together, and surrounded with paste, are packed in these leaves, and called *Agapa*.

The filamentaceous spiral tissue of the stem is of a light material, which easily catches fire, and is therefore used as tinder. The juice of the *Musa* has the very inconvenient property of producing brown spots on any white stuff on which it may happen to come, and nothing has yet been found that will discharge it.

ART. V. *A new System of heating Plant Structures.* By  
ALEXANDER FORSYTH.

HEREWITH I send you a section (*fig. 52.*) illustrative of a new system of heating garden structures, generating “bottom-heat” and “top-heat,” moist or dry, without pipes or flues, dung, hot water or steam, tan, or any other fermenting material, by the agency of fire only, in its cheapest and simplest form; that is, an open angle in a killogie. By this contrivance, the labourer, with axe and spade only, may erect a hotbed for a three-light cucumber frame in a summer’s evening, without wasting a penny-worth of materials, not even an iron nail or a rick; for the wooden sleepers marked *d*, being of worthless

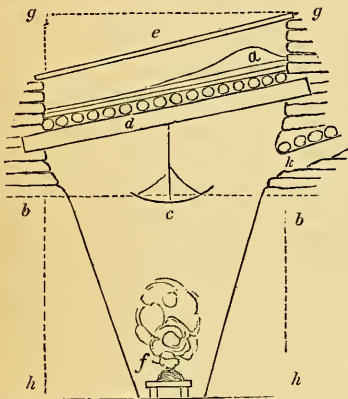

Fig. 52. Section of Hotbed on Forsyth's System.

undressed timber, will be all the better for six months hard drying before they are cut up for fuel, consequently this cannot be called waste. *f* is the fuel on the hearth, being weeds, turves, roots, coals, cinder, &c. &c.; *c* is the radiator, of old iron hoops, platted like a sieve, for the obvious purpose of dispersing and regulating the heat as it ascends to the bed; it is about a square yard in size, and hangs immediately over the angle; *d*, the wooden sleepers, with the flooring of rough sticks laid across them. One layer of turf and one of sand complete the whole bed, ready for the hill (*a*), in which the cucumbers or melons are to be sown. *e*, the rafters and lights: the walls are of turves, to save the expense of the three-light frame or box. *k* is the drain for the smoke, regulated in its draught by a stone on the top of the turf chimney; *bb*, the original ground level. From *g g* to *h h* is 10 ft., *g* to *g* about 6 ft. Whoever wants any

more explanation may be referred to the nearest malt-kiln or corn-kiln, which is perhaps the oldest and most efficient hotbed that is to be found.

The train of ideas that led me to adopt, or rather to press, this system into our service, with the plans for its erection, and the experiments showing its capabilities, will be laid before the public in due time, to show that radiant caloric, when aided in its dispersion by capillary attraction and water, is a powerful agent well adapted to nurse, force, or rear any plant usually grown in English gardens. The accompanying figure will give the labourer a sufficient idea of a cucumber or melon pit; I shall therefore suppose it constructed of turf and worthless timber, with spade and axe only; and as he only wants lights glazed with fragment glass, (which must be very cheap, since it can be bought in boxes, cut to 4 in. by 3 in., at three-pence per square foot,) and the walls of the bed being turf or earth puddled, he will only want a wall-plate and rafters of dressed wood besides the lights, and may thus in one or two evenings erect a three-light hotbed, where he may grow plants, force fruits and vegetables, and propagate florist's flowers and others extensively. In short, there is no saying to what extent gardening may be carried after this manner; since all pipes, flues, masonry, &c., are done away with, and cheap rough materials substituted, of which stone, where it abounds, will be found the best adapted and the most durable, with which the humble amateur will cheerfully grapple at all spare times, till he attain the object that has hitherto been beyond his reach.

Fuel is now the only consideration; but it may be observed that the killogie will contain a stock of fuel and dry it for its own consumption, and also for the family, if necessary, as the space under the bed will be considerable, and may be adapted to fuel-drying. The coarsest fuel, that could not be admitted into any human dwelling, will answer for the hotbed, such as the dung of cattle collected off the roads, the grassy turves by the road side, black soil, sawdust, tanner's bark; but I need not enumerate, for I know that where it is industriously looked after, and with a good will, it will not long be wanting, especially in thinly populated districts, as long as mineral fuel can be found in the earth, and combustible substances on its surface.

I could point out hundreds of situations in Scotland, England, and Wales, where cottages might rise and be surrounded by gardens, in the hills and moors within a day's march of large towns, where the produce would meet a lively market; a donkey's panniers loaded once a week with forced potatoes produced in this way and without glass (only reed covers or the like over the beds), from Christmas to Whitsunday, would realise no mean sum, and benefit the buyer as well as the seller, in such

towns as Bristol, Birmingham, or Manchester, where no such thing is to be had at a price within reach of the middle and lower classes before midsummer. Ah! my dear Sir, if this kingdom were but well farmed, there would be food and labour for all the people; but, if it were gardened, there could not be found hands enough to cultivate its riches, without recalling our emigrants or otherwise increasing the population, to subdue the earth that hath run wild for ages, from sloth and a sort of monkey-like mimicry, that induces one man to sow a spot and a sort of grain merely because others do the same; and, where he cannot get things to grow like other people's, he does not attempt to surmount the barrier by the ladder of his own contrivance, and, with the materials that may abound in the locality, use his best endeavours to equal or surpass his more favoured rivals.

I do not claim the honour of inventing this system of heating, for I learned it from an old farmer who dried oats on a kiln (or hotbed) constructed of sticks and stone in the end of his barn, with an ingle of peats. This was the first and the last straw-kiln I ever saw; and though extremely ill suited as a kiln, from the risk of fire, and the tedious and laborious processes to be gone through, it would have made an excellent hotbed, and on such, as near as circumstances would permit, I reared my tender annuals here this season, and showed them to several practical men, with a red fire just under them. I, therefore, claim the honour of being the first in England, as far as I am aware, that ever raised the heat for a hotbed used in horticulture right over an open fire; and lest it be thought a novelty, let me record, for the honour of Scotland, that I learned it from an old veteran of nearly one hundred years' standing, who related in his own barn, and by the light of the ingle ee, his youthful employments, and among others, and with a rancour that cooled only with his dust, how he bore arms at Culloden in 1745.

In conclusion, therefore, I would hint to all whom it may concern — if you cannot find muck to make a stinking hotbed on the ground, you perhaps, like me, may succeed in making a sweeter and better, ay, and ten times cheaper, on the *first floor*.

*Alton Towers, July 13. 1841.*

P.S. The soot that may impregnate the superincumbent soil will act as a manure if properly managed; and though there may be a burning heat in the bed, no woodlouse will ever enter such a chamber of smoke, nor, indeed, any other creature that breathes the breath of life choose it for an abode, or even endure its atmosphere for a night. No more talk of melon plants running all to leaf, and not fruiting by getting down in the dung of the *bed below* :



the landmark is set ; thus far and no farther dare root of melon or foot of woodlouse come, therefore two of the greatest plagues are stayed.

---

ART. VI. *The Landscape-Gardening of F. L. von Skell of Munich.*  
Translated from the German for the "Gardener's Magazine."

(Continued from p. 415.)

III. *On the Architectural Edifices which are suitable for a Garden.*

1. **THOUGH** every garden ought to be so constituted as to produce a pleasing and even an æsthetical effect, altogether independently of any aid from architecture, yet it cannot be denied that architectural ornaments, judiciously applied, add greatly to the effect of any garden, and even assist in giving it a distinctive character, as such objects are of rare occurrence in the general landscape. In adapting buildings to a garden, great taste and judgment are, however, required, in order that the buildings should neither be too large nor too small, in proportion to the extent of ground which they are required to decorate. Great care should also be taken not to make the buildings too numerous, this being a fault which has been frequently fallen into in celebrated places ; as, for example, at Stowe in England, and at Schwetzingen in the Palatinate of the Rhine : though in the latter case the fault is almost excused, on account of its extremely beautiful temple and other buildings in the noblest style of architecture, which far excel those of every other garden in Europe. The monuments, also, of antiquity cannot be dispensed with ; as each, with its surrounding plantation, forms a picturesque scene of itself.

2. Among the architectural edifices the most suitable for a garden, the temples of the Greeks and Romans, in which they offered their sacrifices to their gods, in all the pomp and magnificence of the Pagan religion, should certainly find a place. The most beautiful forms and proportions are seen in these temples, and it is only in these that the columns of the different orders are seen in all their magnitude and beauty. It is only in temples that the eye can repose on these orders with delight, because then no other object is combined with them to diminish their size, or to weaken their beautiful proportions, and thereby to interrupt the enjoyment the mind is capable of feeling from their contemplation. The most perfect of these temples is only finished by being surmounted by a dome ; and this, and the beautiful entablature of the Greeks, have been handed down to us from remote antiquity, as the forms most worthy of imitation. But as the temples of the ancients were very different in their forms and character, as well as in their proportions and

arrangements, the landscape-gardener should be well acquainted with them all.

Vitruvius, the father of ancient architecture, informs us, that the ancients had fourteen different kinds of character in their temples; and as these have been represented by Daniel Barbaro, by plans and drawings, in his translation of the work of Vitruvius, I will subjoin a few of the most particular of them here.

(1.) The temple which had neither pillars nor pilasters. The proportions of this temple allowed eight parts for the length, four for the breadth, and five for the height. The portico was divided into three parts.

(2.) The temple in *Antis* had eight corner pilasters, with two projecting pillars in the centre (*Vorstehend*), supporting an entablature.

(3.) A second kind of temple in *Antis*, the pillars of which did not project, but were in a straight line between the pilasters. The space between these pillars was four times the diameter of a pillar, and was called *Areóstylos*.

(4.) The temple called *Próstylos*, had four pillars on the front, and two pilasters behind the two corner pillars. The distance between the pillars was called *Diástylos*, and it was three times the diameter of a pillar.

(5.) *Amphiróstylos* was a name given to a temple which had four pillars on the back and front.

(6.) The temple called *Perípteros* had six pillars on the back and front, but had thirteen pillars besides these (counting the corner pillars), and a portico at the side. The distance of these pillars from the wall was the same as that between each pillar; and this width was called *Eústylos*, and was  $2\frac{1}{4}$  diameters of a pillar.

(7.) The temple called *Dípteros* was ornamented by eight pillars on both pediments, and had a portico with a double row of pillars, fifteen in each row, on the long outward side of the temple. The distance between the pillars was called *Sýstylos*; that is, two diameters of a pillar.

(8.) That called *Pseudodípteros* had, like the former temple, eight pillars on both pediments; but the portico only consisted of one row of fifteen pillars, and the pillars were distant from the wall twice the width of the distance between each pillar and the diameter of a pillar.

(9.) *Hypæthros* was a temple that had ten pillars on the fore and back pediments, and which had two rows of pillars on the long outer side, which formed the portico. The distance between the pillars was called *Pycnóstylos*, viz.  $1\frac{1}{2}$  diameter.

(10.) That called *Pseudoperípteros*, had, like the *Perípteros*, six pillars on both pediments, but no portico; that is, no pillars

on the side standing free from the walls, but they rather formed part of it.

(11.) The round temples were of two kinds. The first was called *Monópteros*, because these temples had no walls, but had free standing pillars, with spaces between, which could be seen through.

(12.) The second kind of this temple was called *Perípteros*, with eighteen or twenty pillars standing on a stylobate (as is the case in the temples of Vesta at Tivoli and Rome), which is the third part of the height of the pillar counting the shaft and the chapter, in a circle all round the temple, and which has the fifth part of the whole temple from the outer wall of the cella in projection. The interior diameter of the cella was the same as the height of the pillars, reckoning the shaft and chapter.

4. Vitruvius also distinguishes the five kinds of distances between the columns in the following manner:—

(1.) *Eústylos*, or beautiful-pillared, with  $2\frac{1}{4}$  diameters of a pillars.

(2.) *Sýstylos* had two similar diameters between.

(3.) *Pycnóstylos*, near pillared,  $1\frac{1}{2}$  diameter of a pillar.

(4.) *Diástylos*, 3 diameters.

(5.) *Areóstylos*, wide-pillared, or 4 diameters of a pillar between.

Some of these spaces are too narrow, and others too wide; but, in applying them, we are not bound to abide by them.

I have only given those rules which Vitruvius prescribed for the temples, to show the beginner in the art of gardening that it is not so easy to plan and erect suitable architectural structures in a garden; and that, before doing so, he ought to be well acquainted with the relative proportions of buildings in this elevated style; and to show him that, without studying the beautiful classical works of antiquity, he cannot give a faithful imitation of them in his garden. He can learn more on the subject by studying the works of Palladio, Durand (*Recueil des Edifices anciennes et modernes*, Digodetz (*Antiques de Rome*), Clerissian, Wilkens, Revett, Stuart, Le Roy, &c.

5. The architectural orders given to the temples that were dedicated to the different gods were not the work of chance. On the contrary, attention was often paid by the ancients, in the construction of each temple, to the properties and achievements ascribed to the god to whom it was to be dedicated. Round temples were generally built to Apollo, Jupiter, Bacchus, Fauna, Vesta, &c. The Ionic order was given to the first four, and the Corinthian order to the others. In the other temples, the purest Doric order was given to Minerva, Mars, and Hercules; the Corinthian to Flora, Venus, and the Muses; and the Ionic to Juno, Diana, and Bacchus.

6. The following are the principal kinds of temples in the Greek and Roman styles of architecture:—

(1.) The Propylæa at Athens, which had six Doric pillars, supporting a pediment.

(2.) The temple of Minerva at Athens, which had eight Doric columns, supporting a pediment, and, according to Vitruvius, belongs to *Dípteros*.

(3.) The temple of Theseus at Athens was *Perípteros*, and had six Doric pillars in the front.

(4.) The Portico at Athens was likewise Doric, and had four pillars, *Próstylos*.

(5.) The temple of Apollo at Miletus had ten Ionic pillars in front.

(6.) The temple of Bacchus at Teos had eight pillars, and was *Dípteros*.

(7.) The temples of the sun at Balbec and Palmyra were of the Corinthian order.

(8.) The temple of Jupiter Olympus at Athens had eight Corinthian pillars, supporting a pediment, and was *Dípteros*.

(9.) The Pantheon of Adrian at Athens was also of the Corinthian order, and had ten pillars in front. It was *Hypæthros*.

(10.) The temple of Castor and Pollux, at Naples, had six pillars of the Corinthian order in front, but without a portico, and therefore was *Pseudoperípteros*.

(11.) The temple of Isis at Pompeii had four pillars in front.

(12.) The temple of Concord at Agrigentum, in Sicily, had six short Grecian pillars, placed according to the Doric order, and was *Perípteros*.

(13.) At Pæstum the Greek proportions were also in the Doric order; viz. short pillars in front, and nearly five diameters in height.

(14.) The temple of Fortune in Rome (*Fortuna virilis*) had four pillars of the Ionic order, and was *Próstylos*.

(15.) The temple of Antoninus and Faustus was of the Corinthian order, and had six pillars, supporting a pediment.

(16.) The temple of Concord had six Ionic pillars, with a pediment, and was composed of a mixed style. This temple was either *Próstylos* or *Pseudoperípteros*.

(17.) The temple of Jupiter Stator had eight Corinthian pillars, and was *Dípteros*.

(18.) The temple of Jupiter Tonans had also eight pillars of the Corinthian order, with a pediment, and was *Dípteros*.

(19.) The temple of Nero had twelve Corinthian pillars, supporting a pediment.

(20.) The temple of Mars was Corinthian, and *Dípteros*.

(21.) The portico of Septimus Severus was also Corinthian, and had four pillars, and two corner pilasters.

(22.) The temple of Neptune had eight Corinthian pillars, with a pediment.

(23.) The Corinthian temple at Nismes (*Maison carrée*) had six pillars, and was *Pseudoperipteros*.

(24.) The temple of Bacchus was of a round form.

(25.) The temple of Fauna, and

(26.) The temple of Vesta at Rome and Tivoli, the former of which, as has been already mentioned, had twenty, and the latter eighteen Corinthian pillars, which surrounded an enclosed *cella*, were also of a round form, and were *Peripteros*.

(27.) The celebrated Ionic temple of Diana at Ephesus deserves to be mentioned, as, according to Pliny, the whole population of the country was 200 years engaged in building it; it was 425 ft. in breadth, and was ornamented with 127 pillars.

7. After the Greek and Roman styles of architecture comes next the Gothic; and, although it is far inferior to the former in systematic and regular proportions, it presents the most striking and peculiar forms, beauty, and effects.

The Grecian style of architecture has a character of strength and resistance, from its proportions, and that of the Romans has its arches supported by colossal pillars; while the Gothic has often slender pillars of only 2 or 3 feet in diameter, and yet 60 or 80 feet in height, supporting their arches high in the air, which their spires, in spite of the storms of centuries, seem to pierce through like spears. This Gothic style of architecture seems particularly adapted for buildings for Christian worship, and it should, therefore, be adopted for chapels in gentlemen's parks. I must, however, warn the young landscape-gardener from employing the singular and tasteless style of Chinese architecture, which ought hardly ever to be imitated, and, indeed, is better to be omitted altogether. The Arabian or Indian style of architecture is much more worthy of imitation. (See *Daniel, Langles, Niebuhr, &c.*)

#### IV. *The Situation of Temples in Pleasure-Grounds.*

1. The spot selected for a temple should be considered a matter of importance; and where the situation will permit, the practice of the ancients should be adopted, of erecting temples facing the east.

2. When a temple is erected to the beautiful, tender, and lovely Cupid, Psyche, or Venus, it ought not to be situated in a gloomy thicket, or in any place that is dull and uninviting. It ought to be in the most cheerful and lively situation of the garden, where Nature appears in her most attractive charms, decorated with flowers and flowering shrubs; and where gently

murmuring brooks seem to invite the feathered choir to assist with their song in enlivening the consecrated spot.

3. The temples of Jupiter and Apollo should stand on gently elevated situations, and the plantations around them should consist of slender-growing trees that have a light and cheerful character. A stream, like that of Hippocrene, should have its source near the temple of Apollo, and around it should be a grove dedicated to the Muses, and interspersed with flowering shrubs.

4. The favourite abode of Diana was near the woods, and her most favourite occupation was hunting. A temple dedicated to Diana should therefore be in a wood, as such a situation would be the most suitable for this goddess.

5. Minerva is of great consideration in the arts and sciences. A temple should therefore be dedicated to her in a most important situation, but the style of building should not be of a dull melancholy character.

6. Temples dedicated to Neptune, Amphitrite, Galatea, Thetis, or the Nereides, should be situated on islands, or on the banks of lakes, ponds, or streams.

7. Mercury, the god of eloquence and commerce, the reconciler of disputes, should have a temple dedicated to him on a carriage road, or in the interior of a wood, near a dark-shaded river, which may be supposed to be the Styx, and where he is to appear as the attendant of the departed in Elysium.

8. The temple of Vesta should be on a piece of water, or on a river in a sacred grove, such as the temple of Vesta at Rome, which is situated on the banks of the Tiber.

9. The temple of Bacchus should be on a hill overlooking vineyards; and the temple of Ceres, where a fine view can be obtained of the neighbouring fields of corn.

10. Temples dedicated to Hercules and Vulcan should stand in situations where Nature displays herself powerful, and in bold forms and masses, where piles of rocks have formed terrific caves, and where ancient oaks are seen in abysses and on steep declivities, as emblems of power and strength.

*V. On the different Kinds of Trees, Shrubs, and Flowers, which were particularly dedicated to the different Gods and Goddesses, and which should surround their respective Temples, as Part of their Attributes.*

The British oak (*Quercus Ròbur*) and the common beech (*Fagus sylvática*) were sacred to Jupiter; they were also dedicated to Ceres, Vesta, Rhea, Bacchus, and Sylvanus. The chaplet of oak was the symbol of victory, and the oak tree itself the symbol of power. The civic crown of the Romans was composed of oak leaves, and poets and artists were honoured with wreaths of

oak leaves. Oak groves were the first temples in which the Germans, and also the British druids, performed religious ceremonies. The palm tree (*Phœnix dactylifera*) was also the symbol of victory and peace, and sacred to wedded love, Apollo, and the Muses.

The sweet bay (*Laurus nobilis*), which ornamented the brow of the conqueror, was also sacred to Apollo, as Daphne was transformed, when flying from that god, into a bay tree; and the pythoness, or priestess of the oracle of Apollo at Delphos, decorated herself with a wreath of bay leaves, when she appeared on the tripod. A similar wreath was the ornament of the Muses. Æsculapius and Hygeia, the goddess of health, were also crowned with a wreath of bay.

The myrtle (*Mýrtus communis*) was dedicated to Venus, Ceres, the Graces, and other divinities.

The Scotch fir (*Pinus sylvestris*) was the symbol of the returning and inexhaustible productive power of the earth, and, therefore, dedicated to Cybele, and also to Rhea. The cones of this tree were offered in sacrifice to them.

The silver fir (*Picea excelsa*), and the larch (*Larix europæa*), were dedicated also to Vulcan, Neptune, Faunus, and Pan; to the latter the rush was also dedicated.

The cones of the pines and firs ornamented the ends of the rod, or thyrsus, of the bacchanals in the train of Bacchus, at the festivals of that god.

The cypress (*Cupressus sempervirens*), also, was planted on graves; and it was under it that Orpheus lamented the death of Eurydice. It was on the elm that Diana first tried her arrow; and it, with the dark alder (*Alnus glutinosa*), was dedicated to the Eumenides, or Furies. The three Heliades, or daughters of the sun, Lampetia, Phaethusa, and Ægle, who wept for their brother Phæthon, who was killed by the lightning of Jupiter, were changed into poplars; and as this tree, like the cypress, is of a pyramidal form, and stands our climate quite well, whereas the other does not, it should be planted on graves or among monuments. This tree was also dedicated to Hercules and Mercury. The mountain ash (*Pyrus aucuparia*) was also planted on graves by the ancients, because it was considered famous for sanctity. When this tree is seen growing in the clefts of rocks, or hanging in a slanting direction over venerable ruins, it produces a fine romantic effect.

The weeping willow (*Salix babylonica*) is particularly adapted for tombs. This tree, on account of its almost perpendicularly drooping branches, has a peculiar character of melancholy; and, among all trees, is therefore, perhaps, almost the only one which the most touchingly expresses the pain of temporary separation, as it has not the gloomy melancholy character of the

cypress or the yew, and it is therefore often a pleasant object in gardens, and particularly adapted for murmuring streams.

The weeping birch (*Bétula álba péndula*), and the deciduous cypress (*Taxòdium dístichum*), have somewhat of the same character of melancholy and sorrow, as their branches hang down like those of the weeping willow. They should, therefore, be applied in the same manner.

• The cedar of Lebanon (*Cèdrus Libàni*), the queen of trees, is said to have furnished the timber of the temple of Solomon, that of Diana at Ephesus, and several others. The wooden-work of marriage beds was made of this tree, as a symbol of purity and constancy. This tree was sacred to the Eumenides.

The yew (*Táxus baccàta*) was, with the poppy and the saffron, dedicated to Ceres. This tree was very much used in the ancient symmetrical style of gardening, where it was spoiled by the use of the shears, being clipped into the most unnatural and laughable forms. Its character is gloomy and melancholy; and it should, therefore, only be planted in such situations in the natural garden as are wished to have an expression of melancholy and oneliness.

The plane tree (*Plátanus orientális*) was dedicated to Genius. A temple, or a pantheon, erected to learned men and heroes, and in which their busts ought to be placed, should stand in a grove of *Plátanus*.

It was under the lime tree (*Tília europæa*) that the merry rustic youth assembled; and this tree was also often used as a remembrance of a victory gained, or of any great event that had taken place. It was sacred to Venus. The son of William Tell, the Swiss, is said to have stood under a lime tree when his father shot the apple on his head. Baucis was changed into a lime tree.

The arrows of love spoken of by the poets were made from the wood of the ash (*Fráxinus excélsior*): this tree may therefore be planted in the background of a temple dedicated to Cupid. The ash and the quitch grass (*Tríticum repens*) were also dedicated to Mars.

The birch, or May tree (*Bétula álba*), is dedicated to love and friendship in the month of May: a temple, therefore, when dedicated to these noble feelings, should be surrounded by the birch, as a symbol of love and friendship.

The fruit of the apple tree (*Pÿrus Málus*) was an emblem of the earth, and the attribute of perfection and beauty, and therefore dedicated to Venus, because this prize was adjudged to her by Paris. The apple tree is also the attribute of Hercules, because, in mythological fable, he overcame the dragon which guarded the golden apples in the garden of the Hesperides.

The pear tree (*Pÿrus commúnis*) belonged to Minerva.



The quince (*Cydònia vulgàris*). Its fruit is often considered to be the apples of the Hesperides. It is the attribute of good fortune, love, and fruitfulness, and was sacred to Venus and Hercules.

The cherry tree (*Cérasus vulgàris*). When a temple is dedicated to Pomona, this and the foregoing fruit trees, with their different species, should be planted round it, to form a shade.

The walnut (*Jùglans règia*) was sacred to Jupiter. It was the custom in ancient times to strew the walnuts about at marriages, so that Jupiter might take the newly married couple under his protection.

The mulberry tree (*Mòrus álba*) was the symbol of activity. The tenderly loving Pyramus and Thisbe died under a mulberry tree.

The cornel tree (*Córnus máscula*) was dedicated to Apollo.

The sweet chestnut tree (*Castànea véscà*) was sacred to Jupiter.

The almond tree (*Amýgdalus commùnìs*), on account of the earliness of its flowering, was considered an emblem of activity.

The peach tree (*Pérsica vulgàris*) was sacred to Harpocrates, the god of silence.

The pomegranate (*Pùnica Granàtum*) was an emblem of the beauty and fulness of the earth, and it was sacred to Proserpine.

The fig tree (*Fìcus Cárìca*) was sacred to Bacchus, Saturn, and Mercury, and the symbol, also, of fruitfulness.

The olive tree (*Olea europæa*) was an attribute of Minerva, and the emblem of peace. The leaves of this tree were frequently used in the Corinthian capital instead of those of the acanthus.

The vine (*Vitis vinífera*) was consecrated to Bacchus, and also to Juno, as the protectress of marriage. When the vine is seen twisting round elm trees, and loaded with grapes, it gives the expression of wedded love, concord, and fruitfulness.

(To be continued.)

ART. VII. *Measurement, Age, &c., of Trees at Blair-Drummond, Scotland.* By JAMES DRUMMOND, Gardener at Blair-Drummond.

IN the year 1836, I measured the height, girt, and spread of the branches of a few of the trees growing in the park of Blair-Drummond, near Stirling, the property of Henry Home Drummond, Esq., the particulars of which are given in the following table, together with a statement of their age, as near as can be ascertained, soil, subsoil, exposure, &c.

| Number. | Name taken from Loudon's<br>Encyclopædia of Plants.    | Age in Years,<br>as near as can be<br>ascertained. | Whole Height<br>of the Tree in<br>Feet | Height of Bole. | Girt at 2 ft.<br>from the Ground. | Girt at 3½ ft.<br>from the Ground. | Diameter of the<br>Spread of the<br>Branches. | Exposure.   | Soil.           | Subsoil.     | Whether Wet<br>or Dry. |
|---------|--|--|--|-----------------|-----------------------------------|------------------------------------|---|---|-----------------|--------------|------------------------|
| 1       | Oak ( <i>Quercus</i> )                                 | 120  | 86                                     | 20 0            | 14 0                              | 12 8                               | 60  | North-east  | Sandy loam      | Cold till    | Rather wet.            |
| 2       | —  | 120  | 77                                     | 13 0            | 12 3                              | 11 1                               | 60  | Free  | Sandy loam      | Rough gravel | Dry.                   |
| 3       | —  | 120  | 77                                     | 18 0            | 12 4                              | 10 6                               | 65  | Free  | Sandy loam      | Rough gravel | Dry.                   |
| 4       | Beech ( <i>Fagus sylvatica</i> )                       | 120  | 100                                    | 9 6             | 17 3                              | 15 1                               | 110   | Free S., N., and E.   | Sandy loam      | Rough gravel | Dry.                   |
| 5       | —  | 120  | 90                                     | 20 0            | 13 10                             | 13 4                               | 60  | Nearly free   | Sandy loam      | Rough gravel | Dry.                   |
| 6       | —  | 120  | 70                                     | 11 0            | 14 9                              | 13 6                               | 70  | Free  | Sandy loam      | Rough gravel | Dry.                   |
| 7       | —  | 120  | 65                                     | 9 0             | 14 9                              | 13 6                               | 70  | Free  | Sandy loam      | Rough gravel | Dry.                   |
| 8       | —  | 120  | 75                                     | 9 0             | 15 6                              | 13 5                               | 84  | Standing between other<br>two beeches on the bank<br>of the river Feith | Sandy loam      | Rough gravel | Pretty dry.            |
| 9       | Purple beech ( <i>F. syl-<br/>vatica atro-rubens</i> ) | 50 to 60   | 50                                     | 6 0             | 6 7                               | 6 3                                | 62  | South   | Sandy loam      | Cold till    | Rather wet.            |
| 10      | Larch ( <i>Larix communis</i> )                        | 100  | 100                                    | 8 8             | 8 8                               | 7 7                                | 20  | Sheltered on all sides  | Sandy loam      | Cold till    | Moist.                 |
| 11      | —  | 100  | 98                                     | 9 4             | 9 4                               | 8 4                                | 20  | Sheltered on all sides  | Sandy loam      | Cold till    | Moist.                 |
| 12      | —  | 100  | 98                                     | 9 9             | 9 9                               | 8 11                               | 30  | Sheltered on all sides  | Sandy loam      | Cold till    | Moist.                 |
| 13      | —  | 100  | 98                                     | 7 10            | 7 10                              | 7 0                                | 20  | Sheltered on all sides  | Sandy loam      | Cold till    | Moist.                 |
| 14      | Sycamore ( <i>Acer Pseu-<br/>do-Platanus</i> )         | 120  | 80                                     | 6 0             | 16 0                              | 15 3                               | 72  | Free  | Light free loam | Rough gravel | Dry.                   |
| 15      | —  | 120  | 55                                     | 10 0            | 11 1                              | 9 9                                | 50  | Free  | Light free loam | Rough gravel | Dry.                   |
| 16      | Elm ( <i>Ulmus campestris</i> )                        | 60   | 70                                     | 10 0            | 7 0                               | 6 7                                | 50  | South aspect  | Sandy loam      | Gravel       | Dry.                   |
| 17      | — ( <i>Ulmus montana</i> )                             | 120  | 79                                     | 11 0            | 9 5                               | 8 7                                | 48  | East  | Light free loam | Rough gravel | Dry.                   |
| 18      | Ash ( <i>Fraxinus excelsior</i> )                      | 120  | 82                                     | 13 0            | 10 3                              | 8 10                               | 56  | Free  | Light free loam | Rough gravel | Dry.                   |
| 19      | Pine ( <i>Pinus sylvestris</i> )                       | 120  | 83                                     | 35 0            | 8 10                              | 8 6                                | 20  | Free  | Sandy loam      | Gravel       | Dry.                   |
| 20      | —  | 120  | 75                                     | 20 0            | 9 3                               | 8 11                               | 40  | Free  | Sandy loam      | Gravel       | Dry.                   |
| 21      | —  | 120  | 70                                     | 30 0            | 8 7                               | 8 5                                | 40  | Free  | Sandy loam      | Gravel       | Dry.                   |
| 22      | —  | 120  | 70                                     | 20 0            | 10 3                              | 10 3                               | 50  | South-west  | Sandy loam      | Gravel       | Dry.                   |
| 23      | Lime ( <i>Tilia rubra</i> )                            | 120  | 60                                     | 10 0            | 11 6                              | 8 0                                | 48  | Free  | Clay loam       | Gravel       | Wet.                   |
| 24      | —  | 120  | 65                                     | 9 0             | 10 0                              | 9 0                                | 54  | Free  | Clay loam       | Gravel       | Wet.                   |

|     |  |          |       |                |     |                        |   |                     |                  |        |
|-----|--|----------|-------|----------------|-----|------------------------|---|---------------------|------------------|--------|
| 25  | Silver fir ( <i>Abies Picea</i> )            | 90       | 9 10  | 8 10           | 36  | North-east             | - | Brown clay loam     | Red sandstone    | Damp.  |
| 26  | -  | 85       | 8 3   | 7 9            | 36  | North-east             | - | Brown clay loam     | Red do. rock     | Damp.  |
| 27  | -  | 86       | 7 7   | 7 3            | 30  | North-east             | - | Brown clay loam     | Red do. rock     | Damp.  |
| 28  | -  | 75       | 11 9  | 11 5           | 45  | South                  | - | Sandy loam          | Gravel           | Dry.   |
| 29  | Weymouth Pine ( <i>Pinus</i> )               | 120      | 7 9   | 7 6            | 42  | Surrounded by others   | - | Sandy loam          | Cold till        | Moist. |
| 30  | Ströbus                                      | 22       | 2 3   | 2 1            | 12  | Sheltered all round    | - | Dead sand           | Small gravel     | Dry.   |
| 31  | Aspen tree ( <i>P. trémula</i> )             | 60       | 10 6  | 9 9            | 60  | South-west, low        | - | Peat earth and sand | Sandy            | Wet.   |
| 32  | -  | 95       | 5 0   | 8 9            | 50  | Low-lying ground, free | - | Stiff loam          | Gravel           | Wet.   |
| 33  | Norway spruce ( <i>A. comm.</i> )            | 120      | 45    | 10 6           | 8 3 | South-west             | - | Stiff loam          | Gravel           | Dry.   |
| 34  | -  | 120      | 95    | 8 3            | 6 7 | South                  | - | Light sandy loam    | Cold till        | Wet.   |
| 35  | -  | 50 to 60 | 7 0   | 8 4            | 45  | Sheltered N. and E.    | - | Peat earth and sand | Sand             | Wet.   |
| 36  | -  | 50 to 60 | 60    | 7 6            | 35  | Sheltered on all sides | - | Sandy peat          | Sand             | Wet.   |
| 37  | -  | 50 to 60 | 67    | 9 6            | 45  | Sheltered on all sides | - | Sandy peat          | Sand             | Wet.   |
| 38  | Birch ( <i>Bétula álba</i> )                 | 100      | 20 0  | 9 3            | 48  | North                  | - | Sandy loam          | Cold till        | Damp.  |
| 39  | -  | 60 to 70 | 60    | 12 0           | 55  | Low sheltered place    | - | Sandy peat          | Sandy            | Damp.  |
| 40  | -  | 70       | 16 10 | 10 4           | 60  | Low sheltered place    | - | Sandy peat          | Sandy            | Damp.  |
| 41  | Spanish chestnut ( <i>C. véscá</i> )         | 50 to 60 | 60    | 6 5            | 30  | North                  | - | Fine sand           | Sand             | Dry.   |
| 42  | -  | 50 to 60 | 65    | 14 0           | 50  | North                  | - | Sandy loam          | Sand             | Dry.   |
| 43  | Holly ( <i>Ilex Aquifólium</i> )             | 120      | 35    | 6 0            | 45  | Free                   | - | Sandy loam          | Gravel           | Dry.   |
| 44  | -  | 120      | 59    | 8 0            | 39  | Sheltered              | - | Sandy loam          | Till             | Damp.  |
| 45  | -  | 40 to 50 | 45    | 6 0            | 15  | South                  | - | Fine sand           | Strong sand      | Dry.   |
| 46  | Cedar of Lebanon                             | 40 to 50 | 45    | 4 0            | 3 6 | North                  | - | Light sand          | Ferrugin. gravel | Dry.   |
| 47  | Arbor vitæ ( <i>Thuja occidentális</i> )     | 40 to 50 | 45    | 4 0            | 12  | South                  | - | Light sand          | Rough sand       | Dry.   |
| 48  | -  | 40 to 50 | 40    | 3 8            | 12  | South                  | - | Light sand          | Rough sand       | Dry.   |
| 49  | Portugal laurel ( <i>Prúnus lusitánica</i> ) | 40 to 50 | 25    | 3 0            | 12  | South-west             | - | Light sand          | Rough sand       | Dry.   |
| 50  | -  | 40 to 50 | 30    | from the roots | 45  | South-west             | - | Light sand          | Rough sand       | Dry.   |
| 51  | Red cedar                                    | 40 to 50 | 30    | near the roots | 50  | South                  | - | Light sand          | Rough sand       | Dry.   |
| 52* | Walnut ( <i>Júglans régia</i> )              | ?        | 70    | 2 9            | 12  | Free                   | - | Rich alluvial soil  | Clay             | Damp.  |
| 53  | Scotch fir ( <i>P. sylvéstris</i> )          | ?        | 75    | 6 0            | 45  | Free                   | - | Rich alluvial soil  | Clay             | Damp.  |
| 54  | Pear tree                                    | ?        | 30    | 5 0            | 48  | Free                   | - | Rich alluvial soil  | Clay             | Damp.  |
| 55  | Sycamore                                     | ?        | 60    | 24 0           | 36  | Free                   | - | Free loam           | Sandstone        | Dry.   |
| 56  | Ash tree                                     | ?        | 88    | 20 0           | 36  | Free                   | - | Free loam           | Sandstone        | Dry.   |
| 57  | -  | ?        | 83    | 20 0           | 60  | Free                   | - | Free loam           | Sandstone        | Dry.   |
| 58  | Sàlix álba                                   | ?        | -     | 9 8            | -   | North                  | - | Rich alluvial       | Clay             | Damp.  |

\* Nos. 52. to 58. are trees growing at Burnbank, on the estate of Blair-Drummond, beyond the boundary of the park, and must have been planted before the visitation in 1647; as a large walnut tree, seemingly of the same age as those growing around it, overhangs the tomb of the then proprietor, Sir George Muschet of Burnbank, his lady, and three of their children, the tombstone bearing the above date. The walnut tree divides into two stems or trunks at 6 ft. from the ground; one measures 8 ft. round, the other 7 ft.

The following are a few measurements taken of the girt at  $3\frac{1}{2}$  ft. from the ground, in August 1841; and will show how much has been added to their girts, at that height, between 1836 and 1841:—

|           |                    |   |   |             |
|-----------|--------------------|---|---|-------------|
| Number 1. | Girt 13 ft. 5 in.  | - | - | added 9 in. |
| 4.        | Girt 16 ft. 1 in.  | - | - | added 1 ft. |
| 10.       | Girt 8 ft. 3 in.   | - | - | added 8 in. |
| 11.       | Girt 8 ft. 9 in.   | - | - | added 5 in. |
| 12.       | Girt 9 ft. 4 in.   | - | - | added 5 in. |
| 14.       | Girt 15 ft. 10 in. | - | - | added 7 in. |
| 19.       | Girt 9 ft. 2 in.   | - | - | added 8 in. |
| 30.       | Girt 2 ft. 6 in.   | - | - | added 5 in. |
| 31.       | Girt 10 ft. 3 in.  | - | - | added 6 in. |
| 41.       | Girt 6 ft. 3 in.   | - | - | added 5 in. |
| 42.       | Girt 6 ft. 2 in.   | - | - | added 5 in. |
| 52.       | Girt 11 ft. 10 in. | - | - | added 3 in. |

Measured the girt at  $3\frac{1}{2}$  ft. from the ground of a few larches growing in a light sandy soil, south aspect, August 1831; age about 60 years. One was 8 ft. 2 in., another 7 ft. 8 in., and another 7 ft. 6 in. Silver firs in the same place, and same age, 8 ft. 9 in., another 8 ft. 7 in., another 8 ft. Measured a mountain ash on the side of the east approach; girt at  $3\frac{1}{2}$  ft. from the ground 5 ft. 5 in., whole height 40 ft., spread of branches 33 ft.; another, girt 5 ft., length of bole 6 ft., spread of branches 24 ft., and height 50 ft. Measured a hawthorn; girt at  $3\frac{1}{2}$  ft. from the ground, 6 ft. 6 in., bole 4 ft. 6 in., whole height 45 ft., spread of branches 45 ft.

---

ART. VIII. *On the Culture of Timber Trees.* By G. L. L.

HAVING lately noticed various communications in the journals devoted to our department of science, from different celebrated English arboriculturists, containing a vast amount of useful information on the planting and rearing of timber trees, I have been induced to cast my mite into the national treasury of knowledge, well aware that there is infinitely greater happiness in imparting knowledge, than in burying it within our own breasts.

From my boyhood to the present moment, I have uninterruptedly continued to cherish a great dislike to the general appearance of our hard woods, or what are commonly termed deciduous forest trees, particularly in their state of nudity, whether as solitary specimens, in groups, or in forest plantations. In the two latter cases, owing to the want of timely and proper pruning, the branches are often very unequal, and rob the trunk of much of its sustenance; besides this evil, they are frequently as fantastically anfractuons as the taste of the ablest rustic-building carpenter can possibly desire; and they invariably

exhibit, from every point of view, such a reticulated mass of irregularity and confusion, as must ever be intolerable to those who have witnessed them in the opposite condition.

As single specimens in pleasure-grounds or in park scenery, nature may be allowed to frolic sometimes absolutely unrestrained; but in forest plantations, where timber or remuneration is the desired aim, art must be called in. My intention at present is merely to give a few hints on a method I never saw yet fully carried out in this country, but which is successfully practised in Belgium. The public roads of that country, except the railroads which are of recent construction, have always been much admired by foreign travellers for their beautiful appearance, there being generally a row of trees on each side.

The trees, whether oak, ash, elm, poplar, or others, are taken from the nursery when they are 15 ft. or more in height, and about the thickness of a man's arm; the lateral branches are all cut off at from 3 in. to 6 in. from the stem, and of course close above a bud: if the lower ones have not been previously cut clean off for from 5 ft. to 7 ft. from the roots, they are cut off now; the top is also cut off in a slanting direction, at about 10 ft. from the roots. The trees are taken up in March and April, without balls of earth; and not remarkably carefully, but precisely after the ordinary manner practised in our nurseries, and they are planted in holes about 3 or 4 feet square. The first year they grow but little; the second year they may be said to commence their growth, when the uppermost shoot is trained for the leader. As the tree progresses, it is pruned every year, if necessary, in winter or early in spring, cutting out all the cross and unequal branches, and thinning those that are or may become crowded. At first, the upper part of the tree is got at by means of a step-ladder; but as soon as it becomes stout enough, the pruner ascends by the assistance of a cord and climbing spurs. These spurs are fastened on by means of leather straps, which pass round the leg, and are attached to an iron rod reaching from the stirrup of the spur, up the outside of the leg, to near the knee. Securing the hatchet in a belt round his waist, and passing the cord round the stem, the pruner climbs the loftiest trees with apparently the greatest ease, and cuts out all crooked and useless branches, which are pointed out by the foreman or superintendant, who stands on the ground below. The climbing appears to do no serious injury to the trees, the laceration in the bark being small, and almost immediately healing over.

It is astonishing how well the leading shoots of the decapitated trees blend with the older stem. I believe there would be found some difficulty in making any one, who was ignorant of the fact, believe that the beautiful straight-stemmed trees along the road sides, boulevards, &c., in that country, had their tops cut off when

they were planted; but, by very close inspection, the joint may be discovered in all of them, by the bark being smoother, and a little more shining than that on the other parts: the scar may be said to become entirely obliterated in twenty years.

This treatment causes the trees to present a more fastigate and uniform appearance, than if they had been left unpruned; the branches are also much slenderer than they otherwise would have been; but when the object is to obtain straight and fine timber, it may be safely adopted.

September 10. 1841.

ART. IX. *Observations and Reflections on the Cultivation of the Cácti.* By FREDERICK OTTO.

(Translated from the *Garten Zeitung*, Jan. 2. 1841, p. 1.)

THERE has already been so much written in this periodical on the cultivation of the *Cácti*, that it might be thought that every thing relating to this group of plants was thoroughly known, and the subject almost exhausted. But this is not the case; and a great deal not yet made known remains to be investigated.

In almost every garden where the *Cácti* are cultivated, a different method is followed; and it is always that which the cultivator finds to be the most suitable and effectual in promoting the growth and vigour of his plants. It is true that, for the cultivation of this family, there is, up to the present moment, no general rule which seems to be commonly received every where. According to the latest accounts of the most recent travellers and collectors, the Mexican mammillarias are found in such a variety of situations, and in such different soils (as may frequently be seen by the earth attached to the roots of the original plants when they first come over), that a great deal more attention should be paid to their soil than has unfortunately been the case hitherto. Many of the species are found on lime, chalk, and the fragments of stones or rocks that have become broken by the action of the atmosphere; and among these may be mentioned the mammillarias discovered in Mexico in 1840, and lately brought here, called *M. Parkinsonii* Ehrenb. and *M. Schlechtendalii*, both of which were found growing on a chalky range of hills in Mexico, near San Onofre im Mineral del Doctor; and according to the *Linnaea*, vol. xiv. p. 375., *M. Humboldtii* is also found on a chalky range of hills between Yzmiquilpan and Mestitlan. *Echinocactus turbiniformis* seems wedded (so to speak) to bare and precipitous rocks; and the *Ariocarpus retusus* flourishes on a moory soil, where it is always moist. Were all these plants, therefore, put in a soil that the gardener might fancy was congenial to them, it stands to reason that they could not grow, as such a treatment would be totally against their nature. If he try to excite the roots by a change

of soil, or by putting the plants in a hotbed full of vapour, he will not succeed; and unfortunately too many gardeners fall into this error, and by this means the best and rarest plants, which have been preserved during a long voyage, have been totally lost by a wrong mode of culture.

Where Nature cannot be imitated exactly, the most earnest wish of the gardener should be to approach her as near as possible, and in this consists the great art of the cultivator.

The different kinds of soils are not alone necessary for the growth of the plants: situation and temperature must also be taken into consideration. For some years back collections of mammillarias, from whatever parts of the world they came, were grown in our hothouses, and many of them are still kept there. The West Indian species, such as *M. simplex*, *prolifera*, and *straminea*, which have been long in our possession, and which really require a greater degree of heat than those from Mexico, probably gave us the idea. We do not take into consideration, that almost all the species brought to us in modern times from Mexico belong to our tepidaria, and therefore require a temperature of from 6° to 8° of Reaumur (45.5° to 50° Fahr.), so as to produce a healthy and vigorous state of vegetation, and some of the species even do better with a less degree of heat. A great many examples might here be given of the alterations that are produced in the form and habit of the mammillarias from Mexico, by their being placed in hothouses; and it is from this circumstance, that those plants that have been raised from seed, or by other means, in Europe, have not the least resemblance to the parent plant, and are therefore received in the trade as new species: indeed, in some instances, the most skilful connoisseurs and the best botanists have been often deceived with these plants. As is the case with most other plants, this family is subject to sport, and these sports we receive in great numbers from their native country: other plants, again, of the same family, which have been kept in an overheated temperature, are hardly to be recognised, and thus errors are propagated, arising from an impossibility of distinguishing the species or variety. If we contemplate the host of varieties of the division *Conothelæ*, which we have partly from their native country and partly from plants raised in Europe, it will confirm this statement.

It may be seen from this, that the Mexican mammillarias, with a few exceptions, should be grown in a much lower temperature than has hitherto been done. To prepare them for it, they should be planted in beds in the open air, so that they may become strong, and remain there till late in the autumn; and it is only thus that the natural habit and peculiar character of the plant can be obtained. When treated in this manner, they

flower plentifully, and produce an abundance of fruit ; and they are not infested by insects, which is unavoidably the case in hothouses.

These are the advantages which are obtained from a successful treatment of this favourite genus of plants. Many gardens now possess a very perfect collection by following this plan.

The Melocácti, on the contrary, require a higher degree of temperature, and therefore ought to be in the hothouse. Most of them come from the West Indies, Curaçoa, St. Thomas's, &c. There are several varieties in this group, which approach, more or less, to the *Melocactus communis*. Whether they are all to be considered as varieties must be, from careful consideration, afterwards determined. Most of the original plants evince by their roots that they grow in a red loamy and stony soil ; and these, in my opinion, should also be cultivated as I have mentioned.

The Echinocácti require somewhat more heat than the mammillarias, yet they may be cultivated in beds in the open air in summer. In winter they should be kept in a temperature of 8° or 10° of Reaumur (50° to 54·5° Fahr.), and ought to have but very little water ; and if they have taken firm root in summer, they may be kept quite dry, and will not be in any danger. From this necessary state of rest, a profusion of flowers will be produced on the plants.

Many doubts still exist as to the species of *Cereus*, as they vary so much both in their habit, and spine and angular formation ; and the situations in which they are found do not seem to make any exception in this respect. A recent traveller and collector informed me that he found from four to six different forms on the same stem, so different that even the greatest connoisseur would have supposed each separate branch to have been another species ; and his specimens confirmed the assertion.

The genus *Cereus*, with the exception of some species, flowers more sparingly than those of *Mammillaria* and *Echinocactus* ; but, from an improved method of cultivation in modern times, many species have been brought into flower that were formerly not expected. Most of the species may be cultivated in the open air, in a protected sunny situation, in summer ; and it is better if they can be on beds that have a little bottom heat at first ; and this can easily be effected in gardens where there is plenty of leaves and manure, as pits can be dug, and these materials put in, and then covered with earth, and the plants sunk into it. They grow extremely well in this manner, are much stronger, and look a great deal better, than when they are continually standing in a hothouse. Several species of Mexican *Cereus* can be kept through the winter in a moderately heated greenhouse. Those alluded to are such as *C. chilensis*, *cinerascens*, *pentálophus*, *ovátus*, *articulátus*, *Martianus*, *flagrifórmis*, *Mallisoni*, *Smithii*, *Schránkii*, *coccíneus*, *Ackermánni*, &c., with all the varieties of *C. speciosíssimus*, &c.



Our knowledge of the numerous group of the flat-branched *Opúntiæ* is much too limited at present to enable us to determine the species; but we hope, in time, to establish a system, and particularly for those gardens where this tribe of plants is cultivated. What a difference between an *Opúntia* which has been grown in the open air in summer, and one which has been kept in a hothouse! The difference is, indeed, so great, that it is hardly to be believed. The most effectual manner of cultivating them, in winter, is to take great care not to keep them too warm, and to see that their growth may not be accelerated, as a stagnation in vegetation should, if possible, be effected in the plants. As soon as the weather is favourable in spring, and strong frosts no longer dreaded, they should be set out in the open air, in a warm protected situation, and treated in every respect as much as possible like the genus *Cereus*. Bottom heat, however, is not necessary for them in the open air, as they thrive better without it; the different species assuming a more distinct character, and having a greater profusion of flowers.

How very different, also, are the *O. glomeratæ*, grown in the open air in summer, and in the cold greenhouse in winter, to those that have been continually in a hothouse, the temperature of which is not natural to them. The same may be said of *O. cylindræa*, and particularly *O. túnica*, *excuviatà*, *imbricatà*, *Stapèlia*, and *decipiens*. The first mentioned never has a stem in its native country or in our cold greenhouses, but has, on the contrary, a full branchless *cæspes*, in the form of a hedgehog. This appearance is not uncommon, even on specimens from their native country; but their natural form and character are destroyed by an injudicious mode of culture in our houses.

Most of the species from North America, from Mexico, Chili, and the South of Europe, may be kept through the winter without fear of danger, by putting them in a temperate dry greenhouse. If put in a hothouse for the winter, they will soon become sickly, from attacks of the scale and other insects. Dr. L. Pfeiffer's description and synonymes of the living *Cácti* in the German gardens point out the native country of every species of *Cácti*, and should, therefore, be used as a guide by every cultivator.

---

ART. X. *On the Culture of the splendid Lake Rose, Nelúmbium speciòsum* Willd. By M. LÜBECK, Garden Director to Count Harrach, at Bruck on the Leitha.

(Translated from the *Verhandlungen, &c., Berlin*, vol. ii. p. 387.)

THIS beautiful water-plant, so well known in the East and West Indies, Persia, and in China, where it is the ornament of the

lakes and pieces of water in gardens, not even suffering from the severest cold in Pekin, was introduced into England in 1784, by the celebrated Sir Joseph Banks, where, after being cultivated for a long time, it was first flowered in 1797, by Mr. Liptard, at Mile-end; and in 1804, the second time, at the well known and celebrated Sir Charles Greville's, at Paddington, whence seeds were imported to this garden.

My first attempts at rearing these beautiful water-plants were very unsuccessful for several years, although I followed the English method. The seeds were put in leaden four-cornered vessels, half-filled with the muddy slime from the river, and sunk in a tan-bed. It is true they germinated, and even throve very well throughout the summer, but the very strongest of them perished in winter. I therefore concluded that, although these plants require a hothouse in our climate, a tan-bed is not only unnecessary, but even destructive. In order, therefore, to succeed in cultivating these splendid plants, so valuable on account of their height, and the large shield-like form of their leaves, I adopted the following method. As the seeds of these plants germinate the best when they have been kept a long time (the germinating power being very long retained), I took some that had been kept several years, and after having gently opened them at the point, so as to admit of the entrance of water to assist in germination, I put them in a wide-mouthed glass, containing about a quart of river water, and set it on the shelf very near the window. When there was fine weather with sunshine, the seeds germinated in the course of a fortnight or three weeks, but when the sun does not shine, the glass may be sunk in the tan-bed, taking care, however, that river water that has been standing in the house be poured over it very frequently. As soon as the germ appears over the glass, it ought to be taken out and planted. The first pot chosen for this purpose should be a stock-gillyflower pot, somewhat deep, with the hole at the bottom well stopped up, and a layer of gravel and loam, of about 1 in. thick, put over it. The pot is then half-filled with rich slimy mud, and the best is that in which the common *Nymphæa álba* and *N. lútea* grow. The germinated plant is now put in rather near the edge of the pot, and set on the shelf near the window, and the remaining space in the pot is filled with the kind of water already mentioned. It should remain thus without further treatment (except water being poured over it from time to time) till winter, when it begins to become dormant by degrees; and as soon as this is the case less water should be given, only so as to keep it in a moist slimy condition; and it should then be set at some distance from the window, to pass the winter. About the beginning of March, the germinating plant should be put in a larger and somewhat deeper pot, prepared in the manner prescribed above; great care

being taken in removing it, that the germ of the principal root be not injured; and as much of the ball of earth round the root should be preserved as possible. It should be placed in the same situation in summer as in winter. When, by this treatment, I had kept the plants for two years most successfully through the winter, and the pot was full of roots, I found it necessary, in the third year, to put it in a larger vessel before flowering; a round tub of oak, fir, or larch is the best, an earthenware one will not do. The tub, 2 ft. high, and 1 ft. 6 in. wide, was prepared in the following manner. If it is quite new, it ought first to be seasoned by having something burned in it: the bottom should then be covered about 4 or 5 inches deep with a layer of gravel and loam, and over this should be placed a layer of 7 or 8 inches deep of the mud in which the nymphæas grow, as above described; but when that is not to be had, the rich mud from ponds and rivers in which several water-plants are found, such as *Ceratophýllum demérsum* and the different kinds of potamogetons, is the most desirable. The plant should now be put in the tub thus prepared, taking the greatest care to preserve the ball of earth, and it should be placed in a very light situation, as near the window as possible, the empty space of the tub being filled up with water by degrees, and a fresh supply of it kept up throughout the summer. Although the large leaves were now more than 1 ft. in diameter, and the stem more than 5 ft. above the surface of the water, no flower-buds made their appearance. As the plant seemed to require deeper water, and as further transplanting might be attended with danger, I formed the resolution of placing the tub in a larger one in spring, which was about 3 in. wider and 6 in. deeper; and to prevent any injury being sustained by the flower buds in removing the water from the tub, I had a cock put in about half the height of the outer one; the water was thus carefully drawn off into a watering-pot, and used for watering other plants, a fresh supply being daily put in its place. This method proved so successful, that a flower-bud made its appearance about the middle of July, deep under the water; and by the 16th of August the flower-stalk had attained the height of 6 ft. above the surface of the water, and far above the leaves. The following morning the first flower was expanded, but not completely so; it closed again at noon, and it was only in the mornings of the second and third day that this splendid flower was displayed for the first time (as far as I know) on the Continent in all its splendour. It has flowered every year since, and has produced perfectly ripe seed. I cannot forbear to mention here, that, whenever this splendid plant is grown in a large hothouse of moderate heat, it should be in a large basin, and the form ought undoubtedly to be round; as the strong principal root, from which the leaf and flower buds

proceed, has very much the resemblance of that of the *Arúndo Phragmites*, which is always found round the edge of the vessel, and therefore sustains no injury from opposition. In such a place it must grow in its greatest perfection; and what a splendid and delightful aspect and odour would such a plant and its varieties present when in flower! All the species of *Nymphæa*, and other beautiful water-plants, might be grown in the same basin, and this would render the whole still more splendid.

---

ART. XI. *Observations on the Propagation of the Dahlia.* By C. O.

THE following observations have been suggested by the appearance of a paper on the propagation of the dahlia, published in the Number of your Magazine for last month. That the roots produced by dahlia cuttings, made in a particular manner, will grow, has been proved beyond the possibility of dispute; but it has been as satisfactorily proved, that, if made in a different manner, not one in ten will ever see the light of another year. In order that the roots of dahlia cuttings may produce shoots the following season, it is not necessary that they should be taken off by their attachment to the crown of the old root; but it is absolutely necessary that they should be cut immediately under the insertion of a pair of leaves. Cuttings made by the former method will neither grow stronger nor flower better than those made by the latter; but they are preferable, as having a greater number of buds in the crown, consequently producing a more numerous progeny the following year: those by the latter method can only have the two buds always found in the axils of the leaves; these do sometimes exist in a compound state, and will either be developed or not, according to the health and strength of the tubers.

It has been stated, that the base buds of cuttings made in this manner grow with the growth of the stem. Such may be the case; but I have propagated dahlias by cuttings for many years, and never could recognise such a principle. I am aware that cuttings can be made in such a manner, that the growth of the stem will elevate the buds considerably above the crown of the root, but I never could discover it where the cuttings were pared off close to the buds. If it can be established that the upper part of the tuber extends itself, and becomes a portion of the lower extremity of the stem, then the assertion must be granted; deny this, and the thing is impossible: for if the cutting be taken close to the base of the leaves, then the buds are included in the crown, which is the most essential part of the root; and few, if any, instances can be discovered, where any plant will naturally destroy one of the most important means of its future reproduction. It has further been stated,

“that buds are formed far down in the root; and that, more especially, these are formed in the tubers at the time of ripening, as even old roots on rich land, and not well ripened, did not produce buds.” Let no one trust to this, lest his hopes be grievously disappointed. I am aware that the growers for sale will not rest their faith on it for a future supply. As formerly mentioned, the roots of dahlias produced from cuttings can only have the buds found in the axils of the leaves. I have often examined for my own satisfaction, and never could discover buds on any other part of the root. I have often seen the tubers grow in such a manner that the buds appeared to spring from the base, and not from the crown of the root; but this, on examination, will be found to be only in appearance. This formation of the roots is very frequently found in plants grown in pots; less so in those which have been reared in the open ground. I am not aware that the roots form buds in ripening; I have never seen it: let the root of a dahlia be examined at the earliest period of its growth, and every bud will be seen to exist in embryo; that these are matured with the growth of the root cannot be disputed. The writer of this has taken dahlia roots from the ground when little more than half their season’s growth was over, and certainly anything but well ripened; and these roots sprang with equal vigour the following year, and the buds as numerous as those that had been thoroughly matured.

That the roots of dahlias, in common with the roots of all other plants, in cases where the crown has accidentally or intentionally been destroyed, will make a powerful effort to renew this most important part, every practical man of the slightest observation is aware; but they are equally certain that these efforts are not always successful, and much less so in the dahlia than in most other plants. In consequence of having heard it asserted, that a tuber without a crown, if placed in a favourable situation, would form buds, and ultimately grow, the writer deprived a number of tubers of their buds, planted them in pots, plunged them in a gentle heat, and had them regularly attended to with water, along with other plants placed in the same frame; rootlets were produced, as in other dahlias planted at the same time, but not mutilated in the same manner. No buds ever were organised. The cellular tissue, indeed, was thrown out in irregular masses around the top, and on the surface of the tuber, but always retained its simple structure. I do not mean to infer from the above failure, that the efforts of the vital energy in the root is always abortive, but I will positively assert, that, in nine cases out of ten, the result will be unsatisfactory; which any one possessed of a few dahlia roots may prove to his own satisfaction.

There are few cultivators of the dahlia who have not, at one

time or other, had recourse to the purchase of new and improved kinds, and, I think, few of those persons will be found, who do not conceive that they have cause of complaint from the deceits practised on them by the commercial cultivator; but were these aggrieved individuals to examine with a little discrimination and impartiality, they would find that in very many instances, where the "hue and cry" has been raised against the sale grower, their want of success can be traced to their own mismanagement or careless neglect. At the same time, nurserymen are not blameless, although extenuating circumstances are connected with some of their mistakes. For instance, sending out very small plants at a late season of the year, sending out one variety of dahlia with the name of another attached, or even sending out a cutting in a pot with not a single root; these are contingencies, which, even in the best-regulated establishments, are almost beyond the power of the closest vigilance to prevent, but which no respectable grower will refuse to correct.

The following goes far to prove that dahlia cuttings made without buds at their base will grow and flower as well as those where buds have been retained, but that their roots will not afterwards grow. The writer at one time possessed a seedling dahlia of some merit, and was desirous of having as many plants of it as possible the following year. At the proper season the root was potted, and in due time the shoots made their appearance. The cuttings were taken off, not by their insertion on the root, but above the first pair of leaves; these were pared off close to the buds, and struck in the usual manner. A short time after, another but a weaker shoot was developed in the axils of each of the remaining leaves; when of sufficient strength, these also were made into cuttings, and rooted with the old leaf still attached to their base; finally, the old root was divided into as many plants as could be made of it, and each sort separately distinguished by a particular mark. At the usual time the plants were planted in a piece of well prepared ground; all grew and flowered equally well, and, with few exceptions, the roots of all were equally strong: they were lifted rather early than otherwise, and preserved during the winter in dry sand. The second spring the roots were placed in heat, as formerly. From those of each of the first-made cuttings, two strong, with one or more small, shoots were produced; these were the two buds included in the base of the cutting, and now forming the crown of the plant. Numerous shoots developed themselves from those formed of the divided root of the old plant, but not one ever showed itself from the roots of the secondary cuttings. The cause of this failure is simple, and easy of solution. Although a leaf was attached to the base of each of these cuttings, still there was no bud included; the shoots were formed by anticipation from the buds, which, had the cuttings been taken

under those leaves, would have formed the crown of the future root. In like manner, it will be found, that, if the cuttings are taken 1 in. or more under the leaves, they will strike root, grow, and flower equally well as if they had been taken exactly at the base of the leaves; but the roots are always unproductive.

August 19. 1841.

## MISCELLANEOUS INTELLIGENCE.

### ART. I. *General Notices.*

*GERMINATION of Seeds, &c.*—The following article has appeared anonymously in the *Mark Lane Express*, but as we recognise in it the mind of our highly esteemed correspondent, Mr. Lymburn, we have transferred it to our pages.

*Germination of Seeds.* In the *Mark Lane Express* of the 5th of April, 1841, a correspondent notices that, having damped his mangold-wurzel seed to hasten its germination, he dried part of it with powder of quicklime, to make it sow easier, and found, to his surprise, that the part of the seed which was limed came away some days earlier than the other which was damped only, and kept the lead, as to luxuriance of growth, all the year round. As this is not accidental, but a striking proof of a theory brought forward some years ago, it may, perhaps, interest your readers to have it stated.

Around all the germs of plants destined for the increase of the species, whether the buds or eyes, as they are called, of the tubers of the potato, the buds destined to produce branches on the stems of trees, or the more perfect and separated germ in the seed, the embryo of the future plant,—around all these, embedded in the cotyledons, or seed leaves, of the most of seeds, or in the coverings which surround the seeds or buds, there is a deposit of nourishment laid up, to serve as the food of the young embryo when called into existence in the spring. The general name of albumen has been given to these deposits, which consist of starch or flour, sugar, and gum or mucilage, and sometimes oil; all substances containing albumen, and having been elaborated from it by the organs destined for that purpose in the plant. Before, however, these substances can serve as nourishment, and be received into the latex, or vital sap or blood of the plant, they must be again brought back or reduced by a chemical process into the soluble state from which they were at first elaborated. The milky juice of the corn, from which the farina or starch is elaborated, will be familiar to most of your readers; and, were it possible to preserve it in that state, it would furnish a ready food for the young plant; but, as this would not keep, it is elaborated into starch or flour, a substance which is difficult of decomposition, and in which state it is capable of being preserved, if kept from excess of damp or heat. This will explain to your readers the reason why unripe potatoes or grain germinate and come away in the ground more quickly than when very much ripened: the food is in a more soluble state, and more easily made available for the wants of the young embryo. As the strength of a healthy young plant will in great measure depend upon the quantity of soluble food with which it is furnished, it is thus of great consequence to have the seed placed in circumstances which will most assist the operations of nature in attaining this end. It has been long ago pointed out by M. Raspail and others, that the ultimate particles of starch consist of a substance similar to gum, which he calls dextrine, enclosed in a shell; this substance is not difficult of solution itself, but that cannot take place till the shell is burst, which requires a very high heat and the assistance of other substances, as alkalis, and the principle called diastase, the agent in fermentation. We thus see that the food of animals and plants needs similar

preparation ; in so far, at least, as regards this substance. By the assistance of heat, soda, and yeast (which contains diastase), the flour is prepared into a loaf, which is more easily made available as food in the stomach than would be the grain itself ; so, by adding alkalies to assist in the action of the natural diastase formed by the plant itself from the nitrogen of the seed, or by adding yeast where this is deficient, or other substances containing nitrogen to allow the formation of diastase, and by increasing heat in the soil, we assist and increase the efforts of nature, and a greater produce is the result. Some seeds are the better for being exposed even to a boiling heat, as the acacias of tropical countries, in which the starch is very much concentrated, and difficult to reduce. It has also been ascertained that electricity is connected with all transformations or changes of organic substances, either as cause or effect : when electricity is present, it accelerates or causes chemical decomposition ; and when chemical decomposition takes place, electricity is developed always (says Dr. Carpenter), though, perhaps, in most instances, absorbed again by the new state of the compound. M. Maltuen, in experiments made some years ago with seeds, found that they germinated much sooner at the negative or alkaline pole of a galvanic battery than at the positive or acid pole ; and, following up these discoveries by enclosing seeds in phials of alkalies and acids, he found they germinated quickly in the former, and with difficulty, sometimes not at all, in the latter. Connected with the same subject are the recent experiments of Dr. Horner, on the differently coloured rays of the spectrum ; the violet or deoxidising end produces a chemical effect, similar to the negative or alkaline pole, and the red end produces the opposite or acid effect, by the retention of the oxygen. Guided by these theoretical opinions, I was induced to try their effects on some very old spruce fir seed in 1836, which had been three years out of the cone ; the year before, 1835, some of the same seed did not produce one sixth part of a crop, and I had good reason to suppose it would be worse the next. The year before, when the seed was damped to accelerate germination, it had a musty fungous smell ; and the seed leaves came up yellow, and, hanging by the ends in the ground, had not strength to free themselves from the soil. In 1836, however, after being damped, I added quicklime in the state of powder, which, besides furnishing an alkali, has a great affinity for carbonic acid, which is necessary to be extracted from the starch before it can be made soluble, and which produces heat by concentration of the oxygen and carbon when being extracted. After the seed was thoroughly damped, I sprinkled it with the powder of lime, and kept it damp, by the use of a watering-pan, for ten or twelve days ; at the end of which time it had swelled off plump, and had all the sweet smell of the sugar formed in healthy seed when malted in this way : and, when deposited in the ground, it was not long in pushing through its seed leaves, as healthy, upright, and dark green in the colour as the first year it was sown ; and, like the mangold-wurzel plants of your correspondent, the seedling spruce was strong and healthy. I drew up an account of this experiment for the *Gardener's Magazine*, which was inserted in the spring of 1838, and to which I would refer those wishing for further particulars. Enough, I hope, has been stated to point out the theoretical principles on which the benefits of lime proceed. The reasons why I preferred lime were, its cheapness, and the affinity of quicklime for carbonic acid : as to its alkaline properties, soda is much more powerful, but lime seemed to be that which had produced most effect in the experiments of M. Payen and others on the same subject. The seed must be carefully kept damp till sown, as the dry powder is apt to corrode ; and seeds do not suit well to have their dormant powers brought into action without being sustained, which, if far forward and severely checked, may destroy life altogether. Since I experimented as above on the spruce fir seed, I have not had any other seed so long kept to make trial of ; I have, however, tried it on magnolias and other weak-growing seeds difficult to start, and found them to germinate sooner, and make stronger plants than usual. Some others who have tried it have also found it of benefit. It is to seeds containing their albumen principally in the



form of starch, that it will be of most benefit; and to those which have been hurt by long keeping dry, or being exposed to great heat; those which have been spoiled by dampness have their food decomposed and spoiled. It is difficult, also, to say how far the drying can be endured without being prejudicial, and when the organised tissue, the seat of life, may have its powers of resuming vital activity so far trenched on as to be considered dead. After this has taken place, any stimulus that can be applied can only hasten consumption, as the vital force which should preside over and direct the chemical has fled. Professor Otto of Berlin (as stated by Dr. Lindley, in the *Theory of Horticulture*) has said he found great benefit in applying substances yielding oxygen: perhaps it may have been to seeds containing oil, which, being a substance nearly destitute of oxygen, will, therefore, require an extra quantity of that substance, more than is found in the atmosphere, to reduce the food to a soluble state. I have never found any benefit to result from the application of oxalic acid, the substance recommended as yielding oxygen (how is not stated); but it was to seeds containing starch, as old magnolia and acacia seeds, I applied it. For old seeds of lint, rape, turnip, and other seeds containing oil, the professor's recipe may, therefore, be best. I never found damping or liming productive of much benefit to turnip, fir, and other oily seeds; but to all containing starch or flour, which is by far the greatest number, the lime, I am convinced, will be of great benefit, and this is, perhaps, the main reason why wheat prepared by steeping in lime and other substances, and potatoes dusted with lime after cutting, have been benefited.

*Curdling of Milk.* The albumen of the milk is coagulated by acids, heat, and electricity, or any substance that will act chemically on the milk and produce acidity, as heat and electricity do. The dishes should be carefully cleansed from all substances in which a tendency to decomposition or chemical change may have commenced, in fact from all extraneous substances; and the place kept dry and as cool as possible. If acidity commences, it should be checked by sprinkling a little powdered chalk or carbonate of lime, which is not so saturated with acid but it will take up what little has been formed, and when it subsides may be drained off. To remedy the flavour of turnips, they should be boiled, and salt given; and, a few hours before the time of milking, some other food, as beans, bran, &c., should be given, with more salt: for fat cattle, the turnips should be discontinued some days before killing; the volatile principle that gives flavour is thus got rid of.

*The Gooseberry Caterpillar,* it is said, can only be killed by an infusion of foxglove. I have been very much troubled with it here, and have found the powder of white hellebore, which is more easily got, to be quite sufficient. The caterpillars are on the under side of the leaf; and one man holds up the branches, while another dusts the powder on them from below: if perfectly dry, it spreads in a cloud of dust, and misses none, if well directed; and none it touches will live, if the hellebore be fresh and good. When it gets damp, or is too long kept, it loses its pungency and efficiency; and I have seen frequent disappointments from this cause: if only partially damped, it may be recovered by toasting before the fire in a flat dish. Some prefer to infuse it; but I have always found most benefit from the dry powder, if carefully dusted on the caterpillar from below. The caterpillar may be seen to collapse when the powder touches it, and in a few hours there will be nothing but skin.

*The Use of Sulphate of Lime.* The method advised by Professor Johnston to drive off the superfluous water, so as to make it break smaller, should be the best. As the intention is to expose as much surface to the atmosphere as possible, whatever will make it break into smaller particles should be an advantage; and, to prevent its being agglutinised again into lumps by the rain, it should be spread out thin as soon as possible after being broken. Dr. Liebig's opinion is, that it acts principally by combining with the carbonate of ammonia in the air to form sulphate of ammonia, and thus form a fixed salt in place of one that is volatile. If this is correct, the more surface that

is presented to the air, the more benefit will be the result. Others say it forms a constituent to the plant; and it may also be asked, If the carbonate of ammonia is so near the surface of the ground as to unite with the sulphate of lime spread on it, will it not be washed into the ground by the rains, and thus furnish both carbonic acid and ammonia to the plant? Whatever may be the result of theories, the sulphate of lime is not a volatile substance, and should be spread as thin as possible on the ground; the more extent of surface, the more action should take place.

*Ravages of Worms at the Roots of Corn.* I am of opinion the subject has not been properly investigated. In the *Ayr Advertiser* it was stated, about two years ago, by an intelligent agriculturist, that more of the damage done was owing to the state of the ground than to worms; and I am of opinion there is much truth in this statement. It is necessary the ground should be porous, that water may not stagnate, and that the confined air and heat may be retained in the pores; but, if the fissures are larger, the air will not be confined, and the water and gases retained by the capillary attraction and absorption of the small particles will vanish into the atmosphere, and the roots, finding no nourishment, will perish. This state of the ground may be brought about by want of pulverisation. Clayey stiff land, perhaps, worked in wet weather, will leave hollow places in the soil below the surface; and, though the roots thrive for a time till they have penetrated to these while showery weather continues, they may ultimately, when drought comes on, cause failures, more or less, according to their extent. Wet lands, ploughed early, may be heaved by frost; and some grey heathy soils are naturally too spongy. All these causes may have an effect, and the benefits of rolling may arise more from the consolidating of the ground than from the crushing of the insects; which, as they are embedded in the soil, may not take place to the extent anticipated. The wireworm so much talked of, a long yellow many-footed worm with a brown head, and the millepedes, long lead-coloured worms generally called wireworms, we have never seen destroy anything but solid roots; fibres, as of corn, we should think they do not meddle with. The grub, or cut-worm, a long short thick worm, of a dirty green and brown colour, the larva of the *Tipula*, or crane fly (jenny nettles, and daddy long-legs, are amongst its provincial names), does us most harm in the nursery way; but it eats the plants at the surface of the ground, and I have not observed its ravages on the roots. We have had the roots cut of seedling beech by a bright yellow annulose insect, the larva, I think, of some beetle; and such as these, and the grub also, may produce ravages at times, and may, in turf, when they cannot get to the surface, cut the fibres and not the stem; but the thing, I imagine, wants confirmation; and more harm is laid to the score of these insects than, perhaps, they deserve. — *R. L.*

---

## ART. II. Foreign Notices.

### GERMANY.

*CULTURE of Hepática triloba.* — At the fifty-third meeting of the Society, in Berlin, for promoting the Art of Gardening, on May 6. 1827, the director read a paper from M. Lucanus, apothecary at Halberstadt, on the cultivation of the *Hepática triloba* (*Anemone Hepática*); which, on account of the beauty of its foliage, and rich display of flowers in the end of March and beginning of April, is peculiarly suitable for edgings round beds, and also forms a striking contrast round grass-plots.

M. Lucanus is originally indebted for his collection to the woods, and by cultivation and sowing the seed he has produced about fifty or sixty varieties; which, from the size of the flowers, some double and others semi-double, far exceed in beauty those in a wild state. The colours are: blues of different kinds; indigo blue with white and red anthers, king's blue, medium blue to

Miller's blue, gently varying to a pearl colour, with flat and concave petals : reds, from the deepest tint to a pale pink ; and lilac and violet colours in endless varieties. Some quite white and double ; others single, and only varied by a different-coloured flower-stalk and leaves, and by having the anthers more or less coloured.

He makes the following observations on their cultivation:—The *Hepatica* thrives best on a soil that is rather sandy ; requires no dung, and but very little sun ; and it should be kept rather moist than dry. It becomes a large bushy plant in the course of a few years, and is propagated by dividing the root. As M. Lucanus found the *Hepatica* covered with fallen leaves in a wild state in winter, he adopted the same in his garden, and removed them again in spring, without using the rake, which would have torn up the plants. Afterwards a layer of loose earth, half an inch thick, was laid on. (*Verhandlungen, &c., Berlin*, vol. iv. p. 229.)

*Extracts from the Epistolary Correspondence of Edward Otto, during his Voyage to Cuba, and his Abode there.*—On the 28th of August, 1838, at eight o'clock in the morning, our ship, Julius and Augustus, Capt. Wallis, after being till then detained on account of the very unfavourable state of the weather, at last set sail with a south-west wind, in company with several other vessels, from the port of Hamburg. The wind soon shifted to the west, and increased to such a degree, that at Grauerort, only seven miles from Hamburg, we were obliged to go to anchor. Another attempt only brought us as far as Glückstadt, where we again raised the anchor on the 3d of November, at five o'clock in the morning, and sailed by Cuxhaven at eleven o'clock A. M. A dreadful storm arose in the following night, which lasted till eight in the morning, and which brought us as far as the Channel, but which we did not enter, so as to endanger the ship as little as possible. An account of some terrible disaster having befallen us might certainly have been reported, as the violence of the storm had torn away the board on which was the name of the vessel, and which, very probably, had been washed ashore. But, however, in spite of the weather, neither we nor the ship sustained any material injury ; and our patience only was put to the test when we saw vessels coming from the Channel, and advancing rapidly with a favourable wind. On the 11th of November we at last found ourselves in the Channel, about four miles from the English coast, and were, therefore, just upon the point of leaving Europe. By the unanimous desire of the passengers to bid the last farewell to their friends in this part of the world, an English pilot was allowed to come on board, to whose care a number of letters were committed. This man seemed to have the expectation of being treated with British generosity, as he only asked, as a small indemnification for his services, the sum of five pounds sterling, or thirty-five Prussian dollars !

As soon as we had passed the Channel, the wind began again to be unfavourable, and during the last week in November it raged tremendously, accompanied by so many threatening clouds, that we were obliged to take down all the sails but one ; and as we directed our course to the region of the trade winds, and consequently were obliged to steer to the west coast of Africa, we could only reach about as far as 37° N. L., on the coast of Spain. We were more fortunate in the beginning of December, and on the 2d we found we were in 36° 4' N. L. and 19° 29' W. L., in the sea called the Sargasso Sea. Here we first met with *Fucus natans*, which is said to cover a space resembling a meadow, a few degrees further southward. Hooks, nets, and other implements, were immediately in requisition, to catch all that we could for our further information.\* The first attempt brought us a small species of crab

---

\* The best writer on the *Fucus*, after Humboldt, is J. Purdy, in his Memoir, descriptive and explanatory, to accompany the new chart of the Atlantic Ocean.

and several species of polypus, the latter of which has a great resemblance to the *Fucus*; which, although it abounded here and also further south, we could not discover whole meadows of it, as two or three feet in breadth, and no considerable length, could not merit such a title. Perhaps, however, these strips of *Fucus* may approach nearer each other, and present somewhat the character of a large surface; but we never found this to be the case, and must, therefore, leave the assertion as it has been stated by many others. We found *Sargassum vulgare* Ag. (*Fucus natans* Turn.) on the coast of Africa, and always this one species only; but as we approached the West Indian Islands, in  $19^{\circ} 34'$  N. L. and  $69^{\circ} 25'$  W. L., we met with another, or probably a variety, or a sport of nature. One form had broad leaves, furnished with fine notches? (*Zahnen*) which on some specimens were curly, and on others were quite smooth; others had their berries (*vesiculæ*) as if winged, of a round or angular shape; and there were also an immense number of monstrosities belonging to both these, which, no doubt, can easily be distinguished on dried specimens; *Sargassum bacciferum* Ag. (*Fucus natans* L.) is probably among them, which a closer investigation may hereafter prove. The form of the *Fucus natans* which we found on the African coast was but seldom to be met with in the West Indian waters; and when any came in our way, it had much longer and more slender leaves, with a number of small living creatures attached, even when the specimen was partly in a state of decay, which we carefully collected and preserved. In  $19^{\circ} 7'$  N. L. and  $75^{\circ} 58'$  W. L. (the south-east point of Cuba) the *Fucus* is scarcely any longer seen; and our fishing now generally consisted of sugarcane-haulm and pieces of wood, which, on account of the shell-fish attached to them, was scarcely worth the trouble. As has been supposed, this part is extremely rich in *Fucus*; but, at the time we were there, perhaps the wind and motion of the sea had floated it away to other places. We found, on the contrary, in the Gulfs of Mexico and Florida a great deal of *Fucus*, and quite the same species as we found on the coast of Africa.

To return again to the voyage, we arrived on the 4th of December, at noon, in  $33^{\circ} 15'$  N. L. and  $22^{\circ} 21'$  W. L.; and, on the 9th, in  $24^{\circ} 54'$  N. L. and  $33^{\circ} 9'$  W. L.; where the easterly trade winds begin, and which enabled us to calculate more exactly on the success of the voyage. The starry firmament now began to assume a very different appearance, the Great Bear now went underneath, and other constellations seemed to arise out of the sea in the south, and all shone in this region with a very different splendour from what they do in ours. During the voyage, also, the appearance was very striking; although we approached the winter solstice, we found the days increasing, and the sun went down at half-past six, and rose again at half-past five. We were far from the European winter, as we never had less than  $17^{\circ}$  Reaum. ( $7^{\circ}$  Fabr.) in the shade; the sea was of the same temperature, and the water we had for drinking could only be enjoyed with a little brandy or wine. On the 12th of December we passed the tropic of Capricorn, and now saw the tropical bird, the inhabitant of the tropics, and numerous flying fishes, which, on the 10th of December, in  $24^{\circ} 31'$  N. L. and  $34^{\circ} 31'$  W. L., we had also observed. If it had been possible to have steered through the old Bahama Channel, the sea between the Lucayo Islands and Domingo and Cuba, we should have saved five days' journey. The navigable channel is only about three miles wide, and but little deeper than our ship; and, although the moon shone in all her splendour, the captain was afraid to venture through this narrow way; as, on account of the innumerable coral reefs, the vessel would have been exposed to the greatest danger, the wind then blowing from the north and north-east. It was, therefore, agreed upon, to pass the channel between Domingo and Cuba, so as to gain the southern coast of that island, and then to turn eastward to Havanna. We, therefore, sailed more to the south till we arrived at  $19^{\circ}$  N. L., which we only attained with difficulty, because there was hardly a breath of wind, and we had  $22^{\circ}$  Reaum. ( $18^{\circ}$  Fabr.), and consequently suffered greatly from the heat.

From our calculation we found, on the 23d of December, that we could not be far from the northern coast of the Island of Porto Rico, and by break of day were hailed with the cry of "Land! land!" from the mainmast. It was not, however, Porto Rico, but Cape Cabron, in St. Domingo. Our chronometer was not exactly the best, and the violent storm which we had encountered drove us sometimes backwards and sometimes forwards, and thus disarranged our ship's reckoning. We were now  $4^{\circ}$  more to the westward, that is, in  $19^{\circ} 34'$  N. L. and  $69^{\circ} 25'$  W. L. With what a cry of joy did we respond to the announcement of the not far distant land! and with what delight did I behold it from the top of the mainmast, 120 ft. high! Towards midday, when about four miles from land, we distinctly saw the high and long chain of hills, with the Capes Samana, Cabron, and Vieux François; and, on the twenty-fourth morning, we saw Punta Isabelica (Isabella Point), about two miles from us; and the following day Domingo disappeared, and the eastern point of the Island of Cuba made its appearance; and Cape Maisy and St. Jago de Cuba on the 26th instant. We now steered again more southwards, so as to avoid the coral banks of the Kayman Islands, and by this means came farther up the Mexican Gulf than it was necessary. About the closing of the old year, and before we reached Cape St. Antonio, the western point of Cuba, another storm arose, which proved to be almost more terrific than those we had previously experienced. The ship lay quite on her side, but advanced very rapidly, so that we soon expected to be at the end of the voyage; and, on the 5th of January, we arrived in the harbour of Havanna, after seventy days' sail, during the greater part of which the weather was unfavourable. (*Garten Zeitung*, p. 185., June 15. 1839.)

#### RUSSIA.

*Cronstadt, July 6. 1841.*—Our winter has been uncommonly good, but very severe. From its commencement we never had a thaw, till the return of spring demanded a change of weather; owing to which, the supply of all kinds of provision, except poultry, was most abundant. It is curious to look at the chart, and to think that, at the same moment, I could have on my table fresh fish from the Caspian and White Sea. While furnished during last winter with every luxury, the want of poultry arose from the scarcity of corn, throughout almost all the provinces which are connected with Moscow and Petersburg, and feeding them was too expensive. On the other hand, the severe frosts have done a good deal of harm to the fruit trees, both apples and cherries. The latter are in many cases destroyed, while on the former the fruit spurs have been killed as well as the growth of last year. The summer and autumn of 1840 were most unusually wet, which contributed to fill the wood with an exuberance of sap, prevented its ripening, and rendered it more susceptible of the frost. There is another evil attendant on the frost; it raises the trees bodily, and when they settle again, on the earth's thawing, empty spaces remain about the principal roots, as if dug out by some small animal. To conclude, gardening, in our climate, is a most hazardous thing.—*C.*

---

#### ART. III. Domestic Notices.

##### ENGLAND.

*THE Great American Aloe.*—This plant, which is said to flower but once in a century, and very seldom blooms in this country, may just now be seen in great perfection at Ham Green, about five miles from Bristol, the residence of H. B. Bright, Esq. By a gentleman who, by Mr. Bright's invitation, has seen the aloe, and who, from a long residence in tropical climates, and especially the agave's most indisputable habitat, Mexico, can speak with confidence on the

subject, we are assured that, even in its native country, this singular plant seldom exceeds in beauty and grandeur the specimen now flourishing in our immediate neighbourhood. To many of our readers, the following brief description of this noble plant may be acceptable. *Agave americana*, or the American aloe, is a plant which, when full grown, has a short cylindrical woody stem, which is terminated by hard, fleshy, spiny, sharp-pointed, bluish green leaves, about 6 ft. long, and altogether resembling those of the arborescent aloes. Each of these leaves will continue to exist for many years, so that but a small number have withered away by the time the plant has acquired its full maturity. It is commonly supposed that this occurs only at the end of 100 years: but this, like many other popular opinions, is an error; the period at which the agave arrives at maturity varying, according to circumstances, from ten to fifty, or even seventy years. In hot or otherwise favourable climates, it grows rapidly, and soon arrives at the term of its existence; but in colder regions, or under the care of the gardener, where it is frequently impracticable to attend to all the circumstances that accelerate its development, it requires the longest period that has been assigned to it. Having attained its full growth, it finally produces its gigantic flower-stem, after which it perishes. This stem sometimes is as much as 40 ft. high, and is surrounded by a multitude of branches, arranged in a pyramidal form, with perfect symmetry, and having on their points clusters of greenish yellow flowers, which continue to be produced for two or three months in succession. The native country of the American aloe is the whole of America within the tropics; from the plains nearly on a level with the sea, to stations upon the mountains at an elevation of between 9,000 ft. and 10,000 ft. From these regions it has been transferred to almost every other temperate country; and in Italy, Sicily, and Spain, it has already combined with the date and the palmetto to give a tropical appearance to European scenery. Independently of its beauty and curiosity, this plant is applicable to many useful purposes. Its sap may be made to flow by incisions in the stem, and furnishes a fermented liquor, called by the Mexicans *pulque*; from this an agreeable ardent spirit, called *vino mercal*, is distilled. The fibres of its leaves form a coarse kind of thread; the dried flowering stems are an almost imperishable thatch; an extract from the leaves is made into balls, which will lather water like soap; the fresh leaves themselves, cut into slices, are occasionally given to cattle; and finally, the centre of the flowering stem, split longitudinally, is by no means a bad substitute for a European razor-strop, owing to minute particles of silica forming one of its constituents. Mr. Phelps, the gardener at Ham Green, having had the care of the exceedingly rare collection of exotics naturalised in those most interesting grounds, is proud of his trust, and especially of the great aloe, which has been attended to with the nicest care and science. The roof of the hot-house has been partially removed, and a structure of framework glazed, adapted to the *growing necessity* of the colossal flower-stem; a stage has been erected, and steps formed, so that the observer can open a slide, and look down upon the whole plant. From Mr. Phelps we understand that the family can trace the *great aloe* for ninety-eight years, a singular corroboration of the generally received opinion as to its centenary existence. The flower-stem is at present 23 ft. high, with twenty-seven branches, on which there are upwards of *three thousand blossoms*. The last of these plants which flowered in this country was at Brislington; and so powerful was the attraction, that visitors came from a distance of fifty miles to obtain a sight of it. (*Bath Chronicle*, July 29. 1841.)

*Immense Mushroom*. — On Monday last Mr. Edward Kirby of Chettisham, near Ely, cut a mushroom of the following extraordinary size: — circumference, 5 ft. 3 in.; diameter, 1 ft. 6 in.; stalk, 14 inches round. It weighed 4 lbs., and produced one quart and half a pint of catsup. (*Cambridge Chronicle and Journal*, July 24. 1841.)

THE  
GARDENER'S MAGAZINE,  
NOVEMBER, 1841.

---

ORIGINAL COMMUNICATIONS.

ART. I. *The Principles of Gardening physiologically considered.* By  
G. REGEL, Gardener in the Royal Botanic Garden at Berlin.

(Translated from the *Garten Zeitung*, May 2. 1840, p. 148.)

(Continued from p. 486.)

I. ON THE PROPAGATION OF PLANTS — *continued.*

B. *Propagation by Buds.*

THE bud is the most important part of the plant; for it is only by it, and the various forms which it assumes, that the increase, or propagation, of plants is effected. It appears first as a *normal perfect bud*. Out of this, through various changes, comes the fruit. Secondly, it appears in the *form of a bud*, which does not, however, become developed in the usual way. The metamorphoses of the latter have a more decided and marked individuality; and consist of the *bulb*, *tuber-bulb* (Knollenzwiebel), *bulb-bud* (Zwiebelknöspe), *the seed*, and of a *bud* which by cultivation and casualty is capable of becoming also a perfect individual bud. I do not by any means intend to assert that these germs can assume at will any one of these various forms, for the changes which the bud undergoes in various respects have their origin in its earliest existence. It is in order to direct the attention to the analogy frequently existing between them, and to examine more closely into the principles before laid down, that the first part of this chapter is dedicated, while the second part will consist of the practical propagation of plants by cuttings, buds, leaves, &c., in connexion with these principles.

I. BUDS AND THEIR METAMORPHOSES.

The normal perfect bud, which Frederic Wolff termed a perfect plant, displays in its functions a certain individuality; so that, under certain conditions, it may be considered the germ of an entirely individual plant. Mönch represented it as the part from which the plant, without previous fructifying, is increased; and C. G. Nees von Esenbeck calls it the undeveloped nucleus

of a branch on the perfect plant. The unlimited individuality which the various transformations of the bud display, has been by many authors extended to the normal bud itself. According to this view, the dicotyledonous tree consists of as great a number of single plants as there have been buds produced on it in the course of time, and the union of all these forms a whole which is nourished by one root. This view gives us a lively representation of the creation of a tree; in reality, however, it is not so applicable, as the bud itself can only be made to develop itself as an individual by art.

From the bud in a state of developement proceeds the formation of the young wood; on which account Du Petit Thouars called the cellular tissue (*Faserzellen*) and spiral vessels (*Spiralröhren*), which extend from knot to knot as far as the root, the roots of the bud, but considered the cells of the medullary rays as forming the inner bark. To this Meyen objects that, when, for example, a branch with red wood is grafted on a white one, the new ring of wood formed below the graft has the colour of the stock; that the spiral vessels are jointed; and the cellular tissue seldom extends from knot to knot entire, but that the threads have their points obtusely truncated and rest upon others. He explains it in the following way: "The sap descending from the bud, in the inner bark, is deposited at the sides between the wood and the bark, and is then congealed into a woody substance;" by which he denies that the bud has any immediate effect in forming the wood, but acknowledges it mediately, as in it is prepared the sap for the formation of the wood. The phenomenon, therefore, of a branch deprived of its buds producing no new layer of wood cannot be considered as an objection. Still, from this explanation, the formation of the cellular tissue and spiral vessels remains in obscurity; for though we find everywhere parenchymal cellular tissue formed wherever the descending sap is deposited, yet I know of no other case where it has formed woody fibre, but this of the connexion existing between it and the formation of the inner bark and the roots.

As we further remark, that the formation of roots in cuttings is always in intimate connexion with the formation of young wood, which I shall advert to further in the practical part; I think myself justified in the conclusion, that the whole of the young woody layer proceeding from the bud is analogous to the formation of its roots; but with this difference, that, while the woody fibres of the young wood are united by the medullary rays, in forming the roots they are separated from them, and appear surrounded by the parenchymal cells of the medullary rays. It hence appears, that the new layer of wood is formed from the sap which, descending from the bud, issues from the inner bark; also that the cells of the medullary rays may be considered as a purely lateral formation of the layer of bark; but



that for the formation of the woody fibres another power cooperates, which, as proceeding from the bud representing, as it were, a perfect individual, we may compare to the formation of roots. It would hence appear that the wood of the graft never passes over into the stock, as it must always assume the nature of the surrounding bark from which the creative sap is transmitted; and that the spiral vessels may be jointed, and the cells of the fibres between the knots closed, as the creative sap always strives to assume the cellular form, while the peculiar active power of the bud stretches them to long fibres of various anatomical forms. The property of forming roots is not, however, peculiar to buds, but also to many persistent and succulent leaves; but here there is often a very striking difference. For while, with few exceptions, the roots of the cutting proceed, not from the surface of the cut, but from the sides at the base of the knot under the bud, and are therefore to be considered as proceeding from it, the roots of leaves taken off without any axillary buds come chiefly from the surface of the cut, and sometimes also from the side of it. In some of the gesnerias they spring from the outside of the circular bundle of woody fibre of the leaf-stalk, and may be very clearly distinguished for some depth in the leaf-stalk, and have their origin, as it appears to me, in a new layer of wood that was forming near the old one. Side roots, also, were produced from this ring.

According to their different situations, we distinguish top or terminal buds, axillary buds, and the scattered or adventitious buds which may spring from almost all parts of the plant. These are produced in great numbers on many plants by cutting in the old wood, and they also sometimes appear on the roots and leaf-stalks or petioles of dicotyledons. All buds have an axillary form, which is enveloped in a number of overlapping leafy growths or scales; and, as the continuation of the axis of the parent plant consists of pith, or medulla, and medullary envelope (*Markscheide*) if the bud is growing on a young branch, the pith passes over into it directly; but if the bud proceeds from old wood, the pith is connected with the medullary rays; the passage of the bundle of spiral vessels which form the medullary envelope being tolerably clearly distinguishable. The latter becomes somewhat broader before it ends below the top of the bud, and from it is afterwards formed the inner layer of wood. Over the enlarged end of the medullary envelope, the pith rises convex or conically, forming the medullary point (*Markhügel*). On the outside it is surrounded with a fine brownish network of cellular tissue, which afterwards forms the bark, and passes directly into the outer cells of the bud leaves. At the base of each of these leaves there is the beginning of a new bud, which is never developed as a normal bud. On the upper extremity

of the medullary point lies the core, or rudiment, of the bud, in the middle of all the bud leaves; it is the most important part of the bud, from which all the new growths are formed. According to this, the bud consists in an extension of the axis of the parent plant, surrounded by the leafy appendages which conceal it, and possesses at the base of these the foundation for new buds, and in their core the property of lengthening the axis into a branch. The fruit of every single flower is formed exactly like the bud, and is the representative of the terminal bud of the blossom bough; while the flower itself, the centre of which it occupies, must be considered as the termination of the axis of the blossom bough. The metamorphosed bundle of leaves which form the flower thus stand close over each other, and are developed together with the organs of fructification. As soon, however, after fructification has taken place, as the fruit begins to expand, the other parts of the blossom lose their importance, and mostly fall off. In the same manner as the axil of the branch passes over into the terminal bud, the fruit is formed by a greater or less lengthening of the axis of the flower, which bears the ovula or germ, and is covered with leafy appendages. Link was the first who decidedly contradicted the ideas formerly entertained of the formation of fruit, and recognised the axillary formation as the most important part of all; Schleiden, also, not a great while since, published a similar view, the first principles of which, he, as well as myself, owes to my esteemed instructor Bartling. From that time I have been constantly occupied with this subject; and, in order to make the above more intelligible, I will briefly arrange the principal forms of fructification for our further contemplation.

The fruit-axis consists of the elongation of the pith of the flower stalk, and the bundle of fibres forming the medullary envelope (Märkscheide). The most simple mode of fructification is found in the genus *Taxus*. The ovula, or germ, is seated at the point of the axis, and has its origin in the transformation of the core of the bud. The fruit-case (Fruchthülle) and the bud-case (Eihülle) are, in this form, so slightly distinguished, that it is doubtful whether the single covering that contains the pip, or nut, and is open at the top, is to be considered the bud-cover (Eihülle), or the fruit-cover (Fruchthülle): the calyx of the flower is also wanting; so that the female flower has exactly the form of a bud, the primitive form of which bud remains undeveloped in the axis of the bud-leaves, but the core of which, instead of making a new shoot, is transformed into a germ, and, by fructification, becomes a seed. In a similar manner, but on a higher scale of organisation, the fruit of the *Urticææ* are formed; the female flowers of which are surrounded with an imperfect calyx, but possess a perfect ovula and fruit envelope (Ei- und

Fruchthülle). The form of the fruit in *Polygòneæ*, *Chenopòdeæ*, and *Plumbagíneæ*, is exactly the same; the ovula are sometimes longer and sometimes shorter stalked (having an umbilicus). These are, comparatively, the few examples in which the fruit-axis bears a single ovulum on its point; while, in all other cases, they spring out of the side of it, and appear either at the inner base of the seed or fruit-leaves (*Fruchtblätter*), or from the bundle of fibres of the medullary envelope lengthened beyond the point of insertion of these leaves.

The first form shows, again, the greatest analogy to the bud. The fruit-axis rises hemispherically, spindle, or conically-shaped, over the flower, and is surrounded, as a covering, with several rows of fruit-leaves (*carpophylla*), similar to the bud-leaves. At the base of each of these, the rudiment of the bud, seated on the axis, is metamorphosed into an ovulum, and becomes enclosed in the fruit-leaf, which has a tendency to turn in at the edges, so that the point of insertion must always be in the edges of it, which have grown together. Whether this takes place in the base or top of the single seed, is determined by the length of the umbilicus. From this manner of fructification, it appears that all fruits (*carpidia*) produced in several circles on a fruit-axis can only be one-seeded, as we find in many families of *Ranunculàceæ* and *Dryàdeæ*, such as in *Ranúnculus*, *Myosùrus*, *Anemòne*, *Adònis*, *Magnòlia*, *Potentilla*, *Gèum*, &c. In a similar manner, but only in a whorl, and at the base of a common stalk, the seed-vessels of the *Labiàtæ* and *Boragíneæ* are formed.

The second form, where, in general, many ovula are produced from the bundle of fibres of the medullary envelope (*Markscheide*) rising above the point of insertion of the fruit-leaves, includes the greater part of fructification; and we will proceed from those formations that have a visible fruit-axis to those in which it seems to disappear by degrees.

1. The fruit-axis rises like a pillar, the bundle of vessels forming the medullary tubes (*trophospermia*) ascends to its summit, and develops lengthwise many ovula, which seldom are diminished to one. Two of these bundles of vessels always lie close together, and form a central column (*placenta*), which, on that account, has generally two rows of teeth.

To each of these columns there is a corresponding leaf of those situated at the base of the fruit-axis in a whorl, and which here, as in the bud, only serve as a protection and covering to the axillary growth. In this form there are two principal modifications.

*a.* The edges of the fruit-leaves bend inwards, and their corresponding bundle of fibres grows into them; so that each *placenta*, with its fruit-leaf, forms a little fruit, or seed vessel, for itself. In the *Malvàceæ* and *Geraniàceæ*, where the fruit-axis rises above the fruit, is found the type of this manner of

fructification. The *Onagrariæ* develop round an equally long axis a whorl of many such fruits; the union of these forms the fruit-cluster (*Fruchtknoten*), which is covered by the calyx above it. The sides of the fruit-leaves bent inwards, thus becoming pressed closer to each other, grow together and form the partitions; and, as the cylindrical leaves of the calyx alternate with the fruit-leaves, the individual fruit cannot escape out of this overgrowth, in order, as their formation required, to burst open at the seam in the axis; but this takes place where the leaves of the enclosing calyx have grown together, and, therefore, on the middle rib of the fruit-leaves. This formation is very perceptible in the seed-vessels of the *Ænothèræ*. I have also observed, in the beginning of spring, in the seed-vessels of the *Philadélphus* which had remained on the tree during the winter, and in which the calyx was partly destroyed by the weather, a degenerating into single seed-vessels. In the same manner, with a whorl of three seeds round a very slender fruit-axis, which, apparently, only consists of the placenta, and accordingly, in the regular growth of the fruit, remains attached to the seed, are formed the *Liliacæ* with upper, and the *Irídeæ* with under, fruit-clusters. By the growing together of the sides of the fruit-leaves, the fruit of these plants represents a tripartite capsule. If the parts which grow together, and cause the single compartments of the fruit, are fragile, the fruit separates when it is ripe, and they burst open at their axis; but, if firm, they remain united, and open at the midrib.

The *Euphorbiacæ* also produce, round a more distinct fruit-axis, a whorl of three one- or two-seeded fruits; and, lastly, the *Umbelliferaæ*, only two opposite to each other, which are one-seeded, and also covered by the calyx.

*b.* The edges of the fruit-leaves growing in a whorl round the fruit-axis do not bend towards the fruit-axis, but grow together sideways, and not with their corresponding bundle of vessels. The fruit-axis, therefore, rises in the hollow of the fruit-cluster thus formed, ends under its point, and only the bundle of vessels attached passes over into the stalk. In this manner is formed the fruit of the *Caryophýlleæ*. In the *Polemoniacæ*, the placenta is extended into three elongated angles, which are formed from the pith, and which run towards the midrib of the fruit-leaves, but which they, however, do not always reach (a similar formation also takes place in several species of *Malvæcæ*, between the single fruits on the fruit-axis, as well as on the base of the fruit-cavity of several of the *Caryophýlleæ*); the placentæ are situated in the angles on the central column.

2. The fruit-axis is no longer undivided, but separates into as many parts as there are bundles of fibres, and doubles the number of placentæ and fruit-leaves, or only of placentæ; and

in all these cases, the whorl of fruit-leaves situated at their base is attached to the corresponding bundle of vessels of their placenta, and connected with their edges. The pith of the axis disappears more or less in this form. An intermediate formation between these forms of fructification and the last-mentioned takes place, for example, in *Papàver* and *Nymphæa*, in which the middle column has disappeared; the medullary rays, however, remain, which have many bundles of fibres, and produce ovula over their whole surface. Here, also, two principal modifications occur.

*a.* The separation of the fruit-axis begins under the point, and continues to the base, so that all the bundles of fibres bearing ovula end in a style, and form, as it were, the skeleton of the fruit. The fruit-leaves are so attached to this skeleton, that the two edges of each cover the two separated bundles of vessels belonging to each placenta, so that two bundles of fibres from different placenta are brought together. These grow more or less firmly to a false placenta, which is produced from the inter-grown edges of the fruit-leaves, and which must therefore alternate with the lobes of the scar (*Lappen der Narbe*) formed by the point of the fruit-leaf. In this manner of fructification, if the original placenta should grow undivided, it would rest on the midrib of the fruit-leaf; but I know of no example of this. If the inter-growth of the two bundles of fibres which form the false placenta is weak, they remain fixed, on the bursting of the capsule, to the separating edges of the fruit-leaves, as in *Heliánthemum* and *Parnássia*; but if it is firm and interwoven, on the bursting of the fruit-leaves, the false placenta remains as a skeleton of the fruit, as is beautifully exemplified in *Argemone*. The greater number of variations of this class of fruits arises from the failure of several bundles of vessels, as well as of the corresponding fruit-leaves of the whorl, so that in *Chelidonium* only two placenta and fruit-leaves are found. The separated bundles of fibres grow together, as in *Argemone*, and remain, after the bursting of the fruit-leaves, as two opposite placenta. In *Glaúcium*, these two placenta are also united by an enlargement of the pith of the fruit-axis, which becomes very large, and is covered with a thin epidermis. This growth fills the fruit almost entirely, and divides it into two compartments; so that the two bundles of fibres of each false placenta are separated by it, and lie in the two different compartments. The fruit of the *Cruciferae* is formed in the same simple manner; only the enlargement of the pith covered with an epidermis is much more delicate and slight than in *Glaúcium*. Afterwards it diminishes still more, so that, when the fruit is ripe, the pith is only found in patches between the two membranes of the partition, producing the light and dark spots and stripes on which R. Brown proposed founding generic characteristics. In some, it is, however,

more apparent even in the ripe fruit, as in *Cheiránthus*, and several genera with small seeds. The trophospermia lying on both sides of the partition, in the *Crucíferæ*, grow firmly together to the stigma; and this explains the alternation of the two lobes of the scar (*Narben-lappen*) with the fruit-leaves, the persistence of the style, and the property of the latter (*Ráphanus*, *Erucás-trum*) to form seeds within itself, which must be considered as great difficulties in explaining this form of fructification.

b. The fruit-axis is divided from the top to the base into several parts (*placentæ*), which separate on all sides. The corresponding fruit-leaves bend with their surfaces towards the divisions of the axis, and their edges grow into them. Hence arises, in general, a whorl of loose single fruit or seed-vessels, which, on becoming ripe, mostly open at their axis, in such a manner that, on each edge of the fruit-leaf, one of the bundles of vessels of the placenta remains. The fruits themselves are either many- or single-seeded, and either quite loose or attached at the base, as in *Helléborus*. They also vary with respect to their number. The whorls in *Sempervivum* and *Isopyrum* consist of many fruit; in *Sèdum* and *Dictámnus* of five; in some species of *Spiræa* of three; in *Pæônia officinális*, *Asclèpias*, *Cynánchum*, *Vínca*, and *Nèrium* of two; and, finally, in the *Leguminosæ*, of one fruit, which, when regularly formed, should have also a whorl of loose fruits. Of the transition of these forms of fructification into one another, we have examples in several genera. The various species of the genus *Delphínium* produce sometimes a whorl of five, three, or only one loose fruit; *Nigélla arvensis* and *hispánica* form a whorl of loose seed-vessels only united at the bottom; while *Nigélla satíva* and *damascèna* form the transition to the fructification of the lily tribe, the axes of these seed-vessels rising undivided as far as to the top, and there separating. The empty compartments of the latter arise from the diminution of the middle parenchymal layer of the fruit-leaves, to which *Cysticápnos* forms the obvious transition, for, when the fruit is ripe, the rudiments of it are still visible.

These are the principal modifications of fructifications, under which all the forms as yet known to me are included. To enumerate all the different changes, for example, how the apple, the stone-fruit, or the berry, is produced, does not belong to this place; should I, however, be encouraged by a favourable reception of my views, arising from a firm conviction of their validity, I may enter into this subject more at large in a future work.

The bud and the fruit, therefore, both consist of a continuation of the axis, gifted with the power of reproduction, together with the appendages for their covering, the more or less perfect leafy organs. The axis of the bud pierces its covering, lengthens into a branch, and forms new buds; the axis of the fruit lengthens

only to a certain size, and forms mostly side-ovula, which, till they are ripe, remain concealed by their coverings. It sometimes happens, that, by a general deterioration of the organs of fructification, the fruit-axis grows into a branch, of which we have an example in the double rose. The ovula are formed either from the upper point of the undivided axis, as in *Táxus* and *Urtica* (the rudiment of the ovulum being, like the top of the bud, the first and most important formation, and fixed on the chalaza, a part similar to the medullary point and the surrounding medullary enclosure), or they proceed from the metamorphosis of the primitive bud. In the latter instance they grow sideways out of the axis, either at the base of the fruit-leaves, as in *Ranúnculus*, or on the lengthened bundle of vessels of the medullary coat, which is most usually the case.

(To be continued.)

ART. II. *On the Utility of washing Garden Walls to destroy Insects.*  
By W. P.

I HAVE the management of some trees covering about 600 square yards of wall, which for several years had been so infested with insects, that they neither bore fruit, nor made shoots more than 1 or 2 inches long. I tried every means to get rid of them throughout the summer, by washing them with various mixtures, and also smoking them with tobacco, but it was of no avail; for, although it undoubtedly killed a great number of insects, still the trees were soon again covered with them. As the walls were old, and full of nail-holes, I conjectured that the insects harboured there, and that if I washed the walls in the winter when the trees were unnailed, with something destructive to them, it would have a much better effect than any summer dressing. The result proved that I was right in my supposition, as the trees are now perfectly free from insects, have made excellent wood, and are loaded with fruit.

The following was my method of proceeding. In the spring I had the whole of the trees unnailed and tied to stakes driven in the border; I then washed the walls with the following mixture: half a barrel of cement, one quarter of lime fresh from the kiln, two bushels of soot, and 12 lb. of sulphur, mixed with soap-súds to the consistency of whitewash. This was sufficient for the quantity of wall mentioned; and it was done by a common labourer. I may mention that part of the wall was covered with moss, which now appears to be all killed.

*Hertfordshire, Sept. 4. 1841.*

ART. III. *The Landscape-Gardening of F. L. von Sckell of Munich.*  
Translated from the German for the "Gardener's Magazine."

(Continued from p. 505.)

V. *On the different Kinds of Trees, Shrubs, and Flowers, which were particularly dedicated to the different Gods and Goddesses, and which should surround their respective Temples, as Part of their Attributes*—continued.

THE ivy (*Hédéra Hèlix*) was the emblem of power, and of unvarying youthful vigour, and it was sacred to Bacchus and Hebe. The Bacchantes and their thyrsus, and the Fauns and Satyrs during their orgies, were decorated with ivy. At the marriage ceremony of the Greeks, a branch of ivy was presented to the wedded pair, as an emblem of the marriage contract. The ivy should be planted round the temple of friendship. Its self-security in climbing, and its unalterable green, form an excellent emblem of the constancy and duration of virtue.

The tamarisk (*Támarix gállica*) was sacred to Apollo.

The chaste tree (*Vítex A'gnus cástus*) and the periwinkle (*Vínca mìnor*) were dedicated to Bacchus; and the savin (*Juníperus Sabína*) was dedicated to Saturn.

The box (*Búxus sempervirens*) belonged to Pluto and Cybele.

The sweet marjoram (*Oríganum Majoràna*) was sacred to Hymen, the god of marriage.

The rose was dedicated to Venus and love. It is called the queen of flowers. With it the sacred altars were ornamented, and with it were woven garlands dedicated to the Graces, love, and friendship, which were presented to the innocent bride; and it is only to youth and to unsullied wedded innocence that it can be considered a suitable decoration. It is an attribute, also, of death, because it ornaments the graves, and it drops its leaves like a symbol of perishableness and pain; and the more particularly so when situated at the side of an urn which contains the remains of virtue.

The lily (*Lílium cándidum*) was sacred to Juno. It is the symbol of purity, innocence, modesty, and hope. In the mythological work entitled *Les Siècles Pajens*, by M. l'Abbé S. de Castres, in the 4th volume, p. 266., will be found a list of the plants that were sacred to Juno; and it is added that "among the plants that were the most agreeable to this goddess, were the dictamnus and the lily. The lily was also called Juno's rose *Ròsa Junònia*. (*Gyrald. Hist. Deor.*, syntagm. 2.)"

This beautiful flower is also of great consideration in the Christian religion, as Madame de Genlis has so interestingly explained in her work on plants.

The violet (*Víola odoràta*) was dedicated to Cybele, and used



as an ornament for graves. These delightfully smelling flowers should be planted round shrubs and bushes, and particularly near habitations. The household gods, Lares, were decorated with violets and rosemary.

The forget me not (*Myosòtis palústris*) should decorate any object erected to love and friendship, and should also be planted by the sides of running brooks. The heartsease (*Viola tricolor*) belongs also to love.

The hyacinth (*Hyacínthus orientàlis*) should be planted round the temples of Apollo and Ceres; it was also used to decorate graves.

The poet's narcissus (*Narcíssus poéticus*) was dedicated to Ceres, Proserpine, and the Eumenides.

The safflower (*Cárthamus tinctòrius*) belonged to Ceres and the Eumenides.

The sword lily (*Gladiolus*) was the symbol of eloquence, and should be seen around the temple of Mercury.

The anemone and the everlasting (*Gnaphàlium Stœ'chas*) were dedicated to Juno. It is said by the poets, that Prometheus brought fire from heaven in the hollow stalks of the fennel (*Férula commúnis*).

The French marigold (*Tágetes erécta*) and the chrysanthemum are planted on graves in many parts of Europe. The amaranthus was also dedicated to sorrow. The asphodel, which was sacred to Proserpine, belongs also to those of a sorrowful character.

The mallow was sacred to Osiris.

The opium poppy (*Papàver somníferum*) was dedicated to Ceres and to Juno, as the protectress of wedded fruitfulness. It was also the symbol of sleep, and was therefore also dedicated to Morpheus.

The Indian lotus flower (*Nelumbium speciòsum*) was the attribute of Ceres, of Isis, and of fruitfulness.

The bean (*Vícia Fàba*) was the symbol of death.

The flax (*Lìnum usitatíssimum*) was sacred to Isis.

*Acánthus móllis* has, for more than 2000 years, been the ornament of the Corinthian capital; and, according to tradition, from the following circumstance:—

A young girl died in Corinth who was very much beloved by her nurse. This tender and affectionate woman visited the grave of her young charge, and set on it a basket filled with small dishes and vases, and other playthings, which were highly valued by the deceased, and then covered the whole with a brick. There happened to be an acanthus close by this basket, which grew up by degrees among its wicker-work, till it reached the brick, where the leaves were forced to bend and hang down in the most agreeable forms. The Corinthian statuary and ar-

chitect Callimachus, who lived 540 years before Christ, discovered this harmonious assemblage of nature and art, and from it formed the Corinthian capital, the most perfect style in architecture, which unites in itself all that the purest taste in splendour and perfect beauty could invent in this kind of art.

Henbane (*Hyoscyamus niger*), the *Potentilla reptans*, *Portulaca oleracea*, and the grasses, were dedicated to Mercury.

Corn was dedicated to Isis; and the maiden's hair fern (*Adiantum Capillus Veneris*) to Pluto.

*Juniperus communis* and the *Rhamnus catharticus* were sacred to the Eumenides, or Furies.

The garlick (*Allium Porrum*) was sacred to the Lares, or household gods.

The following eight divinities protected gardens:—

Ceres; Venus; Pomona; Flora; Feronia, nymph of the woods and groves; Priapus; Vertumnus; and Pales, protectress of the flocks.

## VI.

Among the higher architectural objects and decorations, the garden should also include:

1. Egyptian obelisks. These were usually ornamented with hieroglyphics and other symbolical figures, and were used as sundials. These obelisks have a very good effect in a garden, particularly when they are erected on gentle declivities, or on islands, or the banks of lakes, in which their image is reflected. The height was generally nine or ten times the breadth of the base, and the column decreased upwards to about the half, or rather less than the half of the breadth of the base at the top, where it terminated in an obtuse point formed by four flat sloping surfaces. These obelisks can also be ornamented with bas-reliefs, which transmit noble actions to future generations; they should also be decorated with the likenesses of celebrated persons.

2. The Egyptian pyramids were called by Pliny "proofs of the folly of despotism," because more than a hundred thousand men were said to have been employed for twenty years in the erection of one. These edifices were, therefore, only remarkable on account of their enormous size and great durability. Some of them were 682 ft. in breadth, and 625 ft. in height. If pyramids, therefore, are to be erected in a garden, it is natural to suppose that they must be on a very diminished scale; but such an imitation would only be laughable, and it would be much better not to make the attempt.

3. Pillars are much more desirable as ornaments for a garden, and they serve as historical monuments of great events and actions, which are thus handed down to future generations; such,

for example, as the Pillar of Trajan, and that of Antoninus, at Rome, and, in modern times, the Pillar in London, which was erected in 1666, in commemoration of the great fire in that city.

Such pillars are often erected to the memory of excellent sovereigns, to heroes, and talented statesmen, who were represented either on horseback, or in a standing position at the top of the column. They are often built hollow, with a winding stair inside, which conducts to a balcony at the summit, from which a fine view is obtained, such as the minarets on the mosque in the gardens at Schwetzingen. Such pillars should always be more than 10 ft. in diameter (including the square stones of which the pillar is composed), so that the winding stair may be ascended with ease.

There are a great many other symbolical pillars of different forms and intentions, which are more fully treated of in the works of Vignol von Daviler, Dürand, and many other architectural writings.

Termes also, and obtuse pillars, should support the busts of celebrated men, and the garden should likewise be ornamented by urns in the beautiful forms of antiquity, placed in suitable situations for them.

5. The modern garden does not require so many single statues as the ancient geometric garden, where the end of every avenue, every niche, the centre of every square or circular form, or piece of water, had a figure of some kind or another, without particular attention to their execution as works of art, because they were obliged to have so many. Pan reposing on a rock by a brook in a forest, playing on his seven-reeded pipe; a nymph bathing in a stream under an overhanging rock, situated in a recluse and lonely thicket; a faun espied by a nymph; all these might certainly be placed in the garden: but all other figures should be either in temples or in other buildings, particularly when they are valuable as works of art; and no statue should be permitted in the modern garden without the situation in which it is placed be particularly adapted for its character, and the statue itself remarkable for its beauty, which, from the small number required, is not so difficult of attainment as formerly, when so many were in use.

6. Garden structures should not be limited to the antique Greek and Roman temples already mentioned; they should also include buildings in the modern style of architecture, when these are in pure and good taste: such as a beautiful triumphal arch as an entrance; and its decorations and allegories should not be those of Pallas, but of Flora and Diana.

7. A beautiful rustic house, in which the proprietor can live during the finest months of the year in the enjoyment of nature, is a striking ornament in a garden, particularly when it is of a

beautiful form, and commands a fine prospect, and is at the same time protected from high winds, and faces the rising sun.

8. Besides these, the garden ought also to include smaller buildings which have an object in view, and in which a small circle of friends can assemble and amuse themselves. Such buildings may be dedicated to Virtue, Friendship, Fidelity, and Solitude, or to persons who were dear to us; and they should be decorated with delineations of remarkable events, or with poetry, busts, and inscriptions, &c. To these should also be added, ornamented seats for repose, houses containing baths, the best examples of which may be seen in the gardens of Schwetzingen; aviaries; beautifully constructed menageries; greenhouses; and pretty little farm and other rural buildings, which, however, should not bear the stamp of poverty by having straw roofs, and similar marks of indigence. Why should the landscape-gardener (whose particular desire is to make every thing look beautiful) select, and imitate the rustic buildings of the poorest classes with straw roofs? The rural structures alluded to, and which are found in gardens almost everywhere, should be introduced but sparingly, if it is intended that such scenes are to be in good taste, and in the best style of the art.

9. Ruins, also, have a good effect when erected in situations that seem natural for them, but it is very difficult to give them such an appearance as to induce the belief that they exhibit the effects of time, and are not the work of art or any great revolution. Buildings often become ruins from the effects of fire and war, but such are not included here, and ought not to be imitated in art.

In constructing ruins, stone should be used which has the appearance of being decayed by time, such as tufa (Tuffstein). The walls should be of a proper strength and thickness, with cracks of a suitable depth, and other signs of age and destructibility expressed on them; and it should be evident from the remains of such ancient structures, what their original intentions were; and even the manner in which they were constructed should be somewhat guessed at from their appearance. The parts that are thrown down should lie in places where they undoubtedly would have lain from natural circumstances; and the places where they fell from should have the appearance as if they had once been there.

Fragments of ruins ought not, therefore, to be strewn about by chance, and care should be taken that parts of other kinds of ruins may not be placed near them, such as cornices, columns, chapiters, &c.; because it would soon be discovered that such a heterogeneous mass never belonged to the constructed ruin: and, in order to give as much of an appearance of truth as possible to

the artificial ruin, it should be constructed on a fixed plan, and the part which is supposed to have become ruinous from the destruction of time, such as parts of walls, arches, domes, &c., should be only partially constructed, so that they need not be thrown down, as these places can be easily omitted in building; whereas, when it is all equally built up, and the appearance of ruins effected by the use of instruments, the whole building receives too great a shock, and the ruin itself becomes dangerous. A cupola, which is intended to be only the half of the height in the drawing, and a wall in a state of decay, or one in which two thirds of its former height is wished to be shown, should be built in this manner. When portions of the cornices of a pediment, or the facings of a window, are wanted, they need not be put up and then thrown down again, but thrown in where they would have lain according to the laws of gravity.

After the whole ruin is erected, every particular part, such as the cornices, &c., which forms too sharp a profile, and others again which look too new, should be knocked off with an iron mallet, according to the judgment of the artist, so as to give an appearance of the effect of time. These fractures being produced by a blow, and therefore the work of chance, approach much nearer to nature than those which are formed by the art of the stone-mason, and which, indeed, being so much the work of art, do not deceive, as they deviate too much from nature and the truth.

The artist should also be as well acquainted with the manner and spot in which time carries on the work of destruction, and the places in which it is most visible, as with the romantic effect which the breaches and fractures of his ruinous structure are to produce at a certain distance. When we are near, we often think the destruction has been committed with too bold a hand, while, at the same time, when contemplated at a proper point of distance, it seems to shrink into nothing, and has no effect whatever. I was fully convinced of this in constructing the ruins in the gardens at Schwetzingen, and particularly the temple of Mercury, the building of which was particularly under my own directions. Those breaches or ruins which have been effected by the use of the mallet should be sprinkled over, as if by chance, with a colour resembling that of the other part of the building, so as to give it a tone of antiquity, and bring it into harmony with the other parts of the ruin.

10. The situation of the ruins should generally be in a distant part of the park, and particularly on elevated spots, where nature displays her most grave and solemn character; where loneliness and awful stillness reign, where the unseen Æolian harp is heard, where the dark thicket in inseparable masses becomes almost impassable, and where the ancient maple and the oak proudly

raise their heads among the mossy walls, and make known their antiquity. Such melancholy remains of past ages may very suitably be erected in such situations, and the illusion thereby will be much greater.

11. Broad, frequented, and beautifully formed paths should not lead to ruins, because they would be in contradiction with the uninhabited and long deserted structures. Traces of carriage roads, and narrow footpaths winding about through thickets, which lead the traveller with difficulty to these venerable remains of antiquity, are much more suitable.

12. Monuments erected to the memory of virtuous persons, or those who are dear to us, may form an ornament of the garden, and awaken in us the most lively recollections; but I am not of opinion that gardens ought to be the actual place of burial, although many examples can be given of persons being buried there. The peculiar intention of a garden is rather that it should enliven and amuse us, than disturb and distress us by the transience and destructibility of all that is temporal.

The amiable Countess Louisa von Erbach (born Princess of Leiningen), the ornament of her sex both in mind and person, died in the year 1785, far from her paternal home. Her now deceased father, the worthy German Prince of Leiningen Türkheim, who loved the deceased with the greatest tenderness, had a monument erected in his garden at Türkheim in memory of her imperishable virtues and affectionate memory. It consisted of two sorrowful females in the greatest affliction carrying an urn on a bier, which seemed to contain the beloved remains of the deceased, back to her father in his garden at Türkheim. A pall covers the bier and part of the urn, as far as where the name of Louisa is engraved, after which is the following inscription: — “Stop here maidens, set down the urn, that it may receive the lamentations of the deceased’s father in the sacred grove.” \* A rock is situated on one side overshadowed by a weeping willow, ready to receive the urn, and a sacred grove of slender poplars veils the whole in a solemn shade. Such was this monument, which is said to have been destroyed during the French revolution.

A mere simple urn, by the side of a murmuring brook, overshadowed by a weeping willow, and sacred to the memory of a friend or a faithful spouse, whose ashes repose at a distance, is also very suitable, as we can here lament the irreparable loss with that tender, noble, and spiritual feeling of love and friendship, without these being embittered by sensations of a coarser and more unpleasant kind, from the presence of the corruptible remains.

\* If I am not mistaken, this inscription is by Göthe.

VII. *Bridges in Gardens.*

1. Bridges in gardens are very ornamental, and capable of producing a great deal of effect, when beautiful forms are chosen, and the whole constructed according to the scientific rules of art. These bridges may be of stone, iron, or wood; only, when of the latter material, the piers should always be of stone, so that when the bridge is so much out of repair that a new one is required in its place, it may be erected on the same piers, by which means the plants on the banks of the stream remain uninjured, and the communication across is sooner rendered available.

2. I cannot omit mentioning here what are called rustic bridges and rustic seats, which are formed of the natural branches of trees fastened together, and with the moss grown over the bark, so very frequently seen in gardens. Such bridges have no claims as works of art; they are not durable, but even dangerous, and their appearance is poor and miserable. The same may be said of the dirty garden seats of a similar structure, on which the clothes cling to the dry rough branches, and get torn and dirtied.

Besides these playthings, there are many others which offend good taste quite as much as rustic-work, and which cannot be admitted under the name of art in the natural garden. I will give but a few examples of these, which I have seen myself in different gardens; but the respect I have for the proprietors prevents me giving the names.

In a hollow withered stem of an oak stands a hermit, cut out in wood, reading the bible; you are desired to open a small door in the tree, upon doing which, you receive a blow on the head from the hermit's bible! Not far off sits Diogenes in a tub! In another part, a kind of artificial arch is seen, the interior of which is painted over with vines, and called a grotto! You are invited to come in as if to enjoy a fine prospect, and to sit down on a chair furnished with a thick cushion. The moment you sit down, the distressed cries of a cat are heard, as if you had crushed it under the cushion, which causes you to start up again immediately: this witty invention is truly laughable.

In another garden a tower is shown dedicated to Lady Marlborough. A winding staircase leads to the statue of the lady clothed in mourning, who is looking through a telescope at a page who seems to be coming over a distant hill on horseback, and on the telescope are these words: "Ah! Je vois venir le page!"\* The rope which raises and lets fall the trapdoor of

\* "Ah! I see the page coming!"

the tower passes over the open and very colossal fan of my lady. (A very refined idea!) On the wall in the interior of this tower is written a portion of the well known song, "Marlborough s'en va en guerre," &c., over every step, so that it may be sung while ascending.

The hermitage was also introduced in like manner in numerous gardens, because it was thought by many that an English garden could not be without a hermitage, or a place that bore that name. May the young landscape-gardener, however, abstain from mimicking such childish follies, and bear in mind that the gardens of England have not such absurdities!

In erecting and arranging these different kinds of structures, the greatest care must be taken that they are not all seen at once from any point of view. Where the temple of Love stands on the summit of a beautiful declivity surrounded by rose trees, there should be no temple of any other divinity seen from it, nor any structure in any other style of architecture, no Gothic residence, nor monument of sorrow. Bridges may be an exception, because these only belong to roads and rivers, and have no general connexion with the other structures. These different kinds of styles would be quite in opposition one with another, and could never be brought into one harmonious whole; and the more so, as each structure should have a scenery adapted to its style of architecture. These new and unexpected objects, also, strike the traveller with agreeable surprise, and his enjoyment by that means is increased and exalted.

#### VIII. *The first Proceedings on the Spot which is to form the Natural Garden.*

1. When a natural garden is to be formed, the first thing requisite for the landscape-gardener is, to make himself thoroughly acquainted with the spot and the surrounding scenery. He must carefully examine, study, and contemplate all that nature has produced within or beyond this space for the garden, so as to judge whether he can with propriety take advantage of any; because, by doing this, originality, truth, time, and enjoyment are not only obtained, but the expenditure is greatly diminished. He should also avoid, as much as possible, the too precipitate destruction and felling of trees; he should rather bring them into connexion with natural scenes, or with those of his own creation. Water is the life and soul of a natural garden; he should, therefore, do all in his power to produce such an ornament. Nature gives us lakes, ponds, and rivers; she sends forth springs, and produces waterfalls: the landscape-gardener should do the same, if he possibly can. Where nature has given him springs, he should unite them to form lakes, ponds, or rivers, or turn them into waterfalls. When he has a flat surface to work upon, he should raise little elevations, like small



hills, the soil necessary for which purpose should be obtained by excavating lakes, ponds, or rivers; and, while his imagination is occupied with the present and future picture of his own creation, a very complete survey ought to be made of the whole place, not omitting whatever has been effected by nature or art.

2. The fundamental lines of the new garden should then be put on the plan, and be kept in character with the spot itself, and with the surrounding scenery, and true to the æsthetic rules of composition. The artist must bear in mind what his present operations will effect after a lapse of several years; because, without taking this into consideration, the garden would only be the work of chance, and not one produced by the fundamental principles of art. He should also bear in mind that the first forms which nature or his imagination have impressed upon his heart are generally the best to abide by when alterations are necessary; at least I have always found this to be the case from my own experience: and he should finally contemplate his composition from every point of view, to see what effect is produced. It is much more difficult to form a picture in a garden itself, than to make one on the canvass, because the latter is only contemplated from one point of view. Of all things, the landscape-gardener must not forget to take advantage of the external natural beauties, which he must take in when they suit his picture by means of ha-has: "you must call in the country," says Pope.

3. There are, however, cases in which a working plan for the grounds cannot be acted upon; such as a spot selected for a garden, already furnished by nature with beautiful hills and valleys, fine woods, rocks, rivers, lakes, and waterfalls. In such cases the artist has only to follow up and assist nature, taking care to retain as much as possible all the natural beauties; and, when these are too far separated, he must bring them closer together, still retaining the character of a natural picture. He must, therefore, remove the less beautiful from that which is superior, and make it predominate in the purest and most agreeable romantic forms.

When any part of the ground has been disfigured, either by the hand of man or any other circumstance, he must endeavour to restore it to its original line of beauty; and, when a natural wood is either too uniform or not romantic, he must enrich and beautify it by new plantations, and in every respect make it accord with the character of the natural garden. When rocks, waterfalls, springs, or rivers, are concealed from view by bushes, he must, by a prudent and judicious removal, bring them forward in the landscape, without at the same time destroying, or even lessening, that secret and lonely character which surrounds these objects in nature.

When a locality is chosen for a garden, which has already beautiful woods and groups of trees, and even single specimens, they must, if possible, be retained, and united in the forms of the new garden. In cases where a fine wood happens to be in a spot that is totally inconsistent with all the forms of the new garden, where it entirely shuts out fine views, or of itself forms no attractive feature in the landscape, the question should be asked, How can art find its way here without condemning the whole wood to the axe? In the first case mentioned, art must give a new outline to the wood by a partial removal, or addition by planting; in the second, attempts should be made by felling badly grown trees and shrubs, and lopping off branches, to obtain distant prospects, which would also be objects of surprise and astonishment; and, in the last case, a romantic outline should be given to the wood by a new plantation here and there round its edge. Unsightly shrubs or diseased trees ought never to be spared. The course of roads and paths can only be studied in nature herself, and it is only from her that the landscape-gardener can learn how to make a road wind beautifully and agreeably up a hill, and down again to the valley (but more shall be said of this in another place). The artist should never make a plan for a garden in a neighbourhood with which he is not well acquainted, or which he has not seen; or, if he does so, he will commit faults for which he will never be forgiven. He should, also, not trust the execution of his plan to men who do not understand the subject. There are many places laid out from my plans which, in consequence of this error, have not the least resemblance to the original, and which I did not know again myself, and, alas! was obliged to get altered. The beauty of a natural garden depends as much on the execution of the plan, as on the invention of the plan itself.

IX. *On Staking out and Tracing on the Ground the Forms and Outlines of the Natural Garden, with reference to Character, Effect, and Beauty.*

1. After the preceding knowledge of the locality has been obtained, and sketches of it made when necessary, the landscape-gardener is now ready to draw and stake out on the spot itself the actual outlines and forms which he had projected, and to put the commencement of the work in operation. It is true, that all the forms in nature cannot be mechanically delineated and staked out, because they would be stiff, and have no resemblance to nature; such, for example, as hills which descend by degrees in gently waving lines, and unite unperceived their convex forms with the concave formations of the valley; these imperceptible lines of separation in both forms, this gentle transition of the hill to the valley, cannot be defined by staking

out, because the great danger would be incurred of producing an artificial transition, instead of one that is natural.

2. In staking out hills and valleys, therefore, the whole art consists in setting up single stakes to designate the place of the former and its most elevated point; and to mark out the form of the latter and the centre by poles. Many profiles of hills, as well as valleys, on a large scale, can be formed from the preceding observations, and the essential forms and depths of the concave lines of the valley in as natural a manner as possible, and without both declivities being exactly the same.

Those points, also, which the concave lines of the valley show in the section, should be ascertained by the water-level, and marked with pegs. Such geometrical operations are necessary, as they point out to the mechanical labourer where, and how deep, the earth ought to be excavated, so as not to occasion unnecessary labour and expense; but, in this, and also in effecting the formation of the hill and valley, the practised eye of the landscape-gardener, and the feeling for what is beautiful in nature, will be found to be the best guides.

3. In staking out the outlines of the woods, thickets, and groups, the practice is very different. These must be performed with the tracing-staff and with a bold hand, not minutely, but only those principal large powerful outlines, which are capable of producing the greatest effect, and which cannot be expected from many small bends and turns. Such forest boundary lines should often project in bold masses of wood, and they should then recede in like manner, but without the repetition being the same.

We often observe on the outskirts of the natural wood very considerable spaces quite void of trees, and running back into the very depths of the forest, so that they become quite lost to the eye. These recesses are always covered with the richest green carpet of turf; and these, in the secret darkness of the forest, are of equal importance in producing an exceedingly agreeable effect, whether in the general landscape, or in the art of gardening. The side of the forest the farthest from the sun casts a powerful shade, which has a fine effect in the landscape; the other side, on the contrary, is in a full splendour of light; and, at last, both are lost in a solemn darkness.

4. When, therefore, a wood in a garden has similar bold and expressive outlines; when light and shade are picturesquely distributed over it; when the forms of the foreground, and also that of the background, are beautiful, and clearly and distinctly separated from each other; when the foreign and native trees are mixed together in proud masses, and harmoniously grouped; when novelty of colour and form are everywhere apparent, and not to be seen in the natural landscape,

then the art of gardening triumphs, having not only made a faithful imitation of nature, but (although, it is true, with the help of her own treasures from other parts of the world) enriched and beautified, and even transformed, the whole into a garden itself.

5. On similar outlines made by the tracing-staff, whether for the form of the wood or groups, stakes should be fixed 20 ft., 30 ft., and 50 ft. apart. When this is done, the line made by the tracing-staff must be carefully effaced, and it ought not to be touched again either with the hoe or in any other way, as is usually the case\*, with the intention of producing openings in the outskirts of the plantation. Nature exhibits no such sharp and manifest lines in the contour of the forest, but rather a continuation of forms and objects that present no decided line or figure.

6. If so decided a line were effected even by the most skilful landscape-gardener, and trees regularly planted on it, it could never be put in competition with the invisible line formed by nature round the outskirts of the forest. The numerous retreating and projecting points which nature continually displays in the great outline of the forest should be, in a great measure, left to chance, and effected in the following manner.

7. The workmen are distributed among the stakes, which (after the line made by the tracing-staff has been effaced) only serve to show the grand and principal characteristic features; and it is by these that the first gaps in the outline of the forest should be formed among the trees, so as to appear as if they had occurred by chance; and in this way all the small projecting and retreating points of the natural forest are the best imitated. In places, however, where by accident a straight line has been formed, or where the outline does not assume an æsthetic character, the defect can be remedied by forming new openings, and by effacing others which are already made.

8. It may be seen further from this, that the forest should never be surrounded by a soft wavy-formed outline. In nature, as has already been stated, it presents a very different character. It consists of many bold, obtuse, sharp, deep, and gently receding and projecting irregularities; and it is only by such

\* It must here, however, be remembered, that, in digging round bushes or groups (which is unavoidable during the first few years, in order to destroy weeds and promote the growth of the trees), ugly stiff outlines, which are quite intolerable, are frequently formed by the workmen, and by the sharp and abrupt manner of cutting the turf round the groups and plantations. The turf, on the contrary, instead of being trimly cut, should lose itself unseen among the bushes; and neither plantations nor groups should have the turf in defined forms round them, unless you wish to act contrary to the law of nature.

an imitation that we can approach nature, and produce that romantic effect of light and shade which she displays. If the outline of a natural forest is examined, no peculiar and studied form will be found, because such is not the case in nature. Therefore, when trees or shrubs are planted on a line made by the tracing-staff, however natural they may appear to be, they cannot be said to belong to the natural outline of the forest, but entirely to that of art.

9. When, however, all seems to have been done that art could effect, many places may be discovered on the outline of an extensive forest which are not sufficiently characteristic, and are void of romantic effect. In such cases, the uniformity should be interrupted, by planting single trees or groups along part of the outskirts, or at a distance from it of 50, 100, or 200 feet. Sometimes trees that have a light green colour are selected for this purpose, as they stand out more distinctly from the forest behind.

But, as all objects are clearer and more distinct the nearer they are to the eye, the same kind of trees as those of the wood behind might be used in the manner above described; and the more so, as they are much more natural than the other kind of trees, and unite in producing a more romantic unison. There are cases, however, in which trees of lighter tints than those in the wood behind are very much to be preferred; such as when the background of a wood consists of dark alders, which are not only monotonous in their colour, but have a gloomy and melancholy expression.

However unimportant the outline of the forest may appear to those who are deficient in knowledge, or who have not a true feeling for the beauties of nature, it will appear important to those who are more intimately acquainted with living nature, and with the different shades of character she assumes.

10. I must here make the following observations on the wavy line, or line of beauty, which is so often seen in nature:—

This line is but too little known by a great many young gardeners, and is therefore considered as not being very difficult to imitate. It is true, that if such lines were formed of pure geometric circles, and put together like the Latin S, there would not be much art in such an imitation: but nature has nothing to do with such an arrangement, she makes use of no geometric circles; none of her wavy lines, which are repeated *ad infinitum*, are the same; they have always a different expression in every scene, every form and feature appears new, so that no leaf or grain of sand resembles another. Every single object in the whole creation is defined by a wavy line, a line in acute angles, one that is almost straight, one that terminates in a point, or even one that is crooked; therefore,

every object has a different form, but all is beautiful in so much diversity. Who is not, therefore, easily convinced, that it is extremely difficult to imitate nature in all her endless outlines and forms?

11. In staking out the grove, it should be borne in mind, that the single groups and trees along the sides of the paths, or those that form the foreground of the picture, should never form a straight line; that the trees in the grove stand so far from each other, that the most of them, at least, may have room to display their heads; that they should sometimes be quite close together; and that the trees in the grove, although they stand separate, and admit of views between, should form separate scenes of themselves. When this is not attended to, when the trees are at irregular distances, but always appear at the same distance from each other, then the grove is no longer a natural one; because, even in groves, nature disposes of her trees in groups and masses true to her laws, more of which shall be said in another place.

(*To be continued.*)

---

ART. IV. *On the Thinning of Forest Trees.* By GAVIN CREE, Nurseryman and Forest Pruner, Biggar.

THE thinning of plantations is a branch of arboriculture of the highest importance. It may be thought superfluous to enlarge on a subject which has employed the attention of so many eminent rural and political economists; but, be it known that many authors, and these men of eminence too, have published systems not at all beneficial in their practical application. Proposals are often made, and results stated, without, we fear, sufficient evidence of their accuracy. Planters, of course, adopt the plans most agreeable to their different tastes; and thus so many various schemes, with regard to the distance of trees, and the mode of thinning, are in operation, that it is impossible to reduce these plans to any given standard.

My design, at present, is to explain, by the assistance of a table, a system of thinning trees, which I have found to be highly successful, after many years of experimental observation of it. The first point to be considered is, the distance at which trees may be planted from each other, taking into account the height to which they may be expected to attain. Next, I shall take the thinning of twenty-five trees, and detail the different heights at which these thinnings should take place.

The distance at which trees should be planted from each other cannot, in practice, be reduced to mathematical correctness; yet it is possible to make a very near approximation to

the most proper distance, making allowances for variation of soil, degrees of latitude, and altitude. From observations and experiments I have made, I will lay down such general rules as shall enable planters to see the impropriety of invariably planting at the same distance in all situations, from the level of the sea up to altitudes of 1800 ft. Trees on land, at the sea's level, will attain to above 100 ft. in height, in the same time which is required to make them reach 30 ft. at an altitude of 1800 ft. This fact is demonstrative of the impropriety of planting trees at the same distance in different soils and climates. The distance ought to be regulated, likewise, by the height which the tree may be supposed to attain. When a plantation is resolved on, it may be necessary, or, at least, profitable, to examine the nearest plantation (if any be near) in an advanced state, and from it to judge of the probable height or heights the intended plantation may ultimately arrive at. Suppose the calculations regarding height to be 57 ft., 67 ft., and 85 ft., these three numbers are marked in the fourth division and third column of the accompanying table (p. 553.); and on the same lines, to the left hand, in the first column and first division, 2 ft. 6 in. is marked as a suitable distance for the first height, 3 ft. for the second, and 4 ft. for the third : and, in the same manner, the table may be consulted to ascertain the distance at which trees of any given height may be planted from each other.

Trees may be well planted, however, and yet be rendered comparatively valueless from the want of thinning. Many mixed woods and plantations may be seen in which the firs, not exceeding forty years old, have almost died out, and the deciduous trees are often mere poles. By management such as this displays, the proprietor renounces immense gain, and the country is disgraced. It is no less surprising than true, however, that such imperfect growth occurs in trees under the guidance of men who are reputed to be skilled in the management of woods. The most superficial observer must have remarked the comparative slenderness of all plants or trees crowded together, and the superior strength of those sufficiently distant from each other; though trees crowded together in plantations suffer more, at first, from the deficiency of carbonic acid and oxygen (both of which are required for respiration) than from a deficiency of nutriment from the roots. Trees, however, as is fully apparent, are a part of the vegetable creation that can only be brought to the greatest perfection by regular and sufficient support from the soil and atmosphere; and, as they advance in height, it is necessary to give them additional support, that they may increase proportionally in circumference. This can only be effected by taking part of the trees out; which operation, at the same time, prevents in a great measure the occurrence of disease, and

infection, if disease should occur. When kept at regular and sufficient distances, corresponding to their height, by stated thinning, the trees are strengthened by the sun's rays, air, and motion; and all alpine plants, and such as are exposed to frequent agitation from the wind, have a firmer hold of the soil, and live longer, than those which grow in crowded plantations.

The table of distances applies equally to the thinning of woods. It is divided into four divisions, and each division into three columns. The first column in each division is the distance in planting; the second the number of trees per acre; the third the height in feet and inches at which the different thinnings should take place. The trees at 2 ft. 6 in. distance, 6969 per acre: thinning to commence when these are 9 ft. 6 in. in height, according to the first column in the second division. Trees at 5 ft., 1742 per acre: second thinning should commence when 16 ft. 2 in. in height. Trees at 10 ft., 435 per acre: third thinning should commence when 30 ft. 4 in. in height. Trees at 20 ft., 108 per acre: at this distance trees have sufficient room to attain to the height of 57 ft. 2 in.

[In the *Farmer's Register*, published at Glasgow some years ago, is given an engraved illustration of Mr. Cree's mode of planting and thinning trees; but, as we do not think it necessary to the understanding of Mr. Cree's very plain and excellent directions, we have omitted it.]

The theory adapted to the practical principles of thinning mixed woods and plantations is calculated to inches, and demonstrated on the same plan: if it makes the nearest possible approximation to practical correctness, it is all that can be expected. When trees are planted at 2 ft. 6 in. distance, and have risen to the average height of 9 ft., then each alternate tree of each alternate row, that is at the height or above the height of 9 ft., should be taken out: those below this height may stand till they arrive at it.

When any part of a plantation is much exposed to the wind, 1 or 2 feet, or thereabouts, should be taken off the tops of the trees intended to be cut, this being the most effectual way of retaining the shelter, and protecting the others from the effect of high winds.

Next season continue the thinning of the next alternate rows on the same plan; and the trees that had been left formerly from not being 9 ft. high, if now that height, may be taken out or shortened. The trees will now be (mostly) distant 5 ft. by 2 ft. 6 in.

Three or four seasons afterwards the trees may be 14 ft. high; then the alternate rows which have been thinned must have those left on account of shortness either taken out or shortened.



A Table of Distances for Planting and Thinning Trees, per Imperial Acre.

| Distance the Trees may be Planted, in feet and inches. | Number of Trees on each Acre, per distance. | Heights the first thinning should commence at. | Distances after the first thinning. | Number of Trees per distance. | Heights the second thinning commence at. | Distances after the second thinning. | Number of Trees, per distance. | Heights the third thinning should commence at. | Distances after the third thinning. | Number of Trees, per distance. | Heights the Trees are supposed to attain at last. |
|--|---|--|-------------------------------------|-------------------------------|--|--------------------------------------|--------------------------------|--|-------------------------------------|--------------------------------|---|
| 2 6  | 6969  | 9 6  | 5 0                                 | 1742                          | 16 2                                     | 10 0                                 | 435                            | 30 4   | 20 0                                | 108                            | 57 2  |
| 2 7  | 6527  | 9 9  | 5 2                                 | 1631                          | 16 8                                     | 10 4                                 | 407                            | 31 4   | 20 8                                | 101                            | 58 10   |
| 2 8  | 6126  | 10 0   | 5 4                                 | 1530                          | 17 2                                     | 10 8                                 | 382                            | 32 4   | 21 4                                | 95                             | 60 6  |
| 2 9  | 5760  | 10 2   | 5 6                                 | 1440                          | 17 7                                     | 11 0                                 | 360                            | 33 3   | 22 0                                | 90                             | 62 2  |
| 2 10   | 5426  | 10 5   | 5 8                                 | 1356                          | 18 1                                     | 11 4                                 | 339                            | 34 3   | 22 8                                | 84                             | 63 10   |
| 2 11   | 5120  | 10 8   | 5 10                                | 1280                          | 18 7                                     | 11 8                                 | 320                            | 35 3   | 23 4                                | 80                             | 65 6  |
| 3 0  | 4840  | 10 10  | 6 0                                 | 1210                          | 19 0                                     | 12 0                                 | 302                            | 36 2   | 24 0                                | 75                             | 67 5  |
| 3 1  | 4581  | 11 1   | 6 2                                 | 1145                          | 19 6                                     | 12 4                                 | 286                            | 37 2   | 24 8                                | 71                             | 69 0  |
| 3 2  | 4343  | 11 4   | 6 4                                 | 1085                          | 20 0                                     | 12 8                                 | 271                            | 38 2   | 25 4                                | 67                             | 70 7  |
| 3 3  | 4124  | 11 6   | 6 6                                 | 1031                          | 20 6                                     | 13 0                                 | 257                            | 39 1   | 26 0                                | 64                             | 72 2  |
| 3 4  | 3920  | 11 9   | 6 8                                 | 980                           | 20 11                                    | 13 4                                 | 245                            | 40 1   | 26 8                                | 61                             | 73 9  |
| 3 5  | 3731  | 12 0   | 6 10                                | 932                           | 21 5                                     | 13 8                                 | 233                            | 41 1   | 27 4                                | 58                             | 75 4  |
| 3 6  | 3555  | 12 2   | 7 0                                 | 888                           | 21 10                                    | 14 0                                 | 222                            | 42 0   | 28 0                                | 55                             | 76 10   |
| 3 7  | 3392  | 12 5   | 7 2                                 | 848                           | 22 4                                     | 14 4                                 | 212                            | 43 0   | 28 8                                | 53                             | 78 4  |
| 3 8  | 3239  | 12 8   | 7 4                                 | 809                           | 22 10                                    | 14 8                                 | 202                            | 44 0   | 29 4                                | 50                             | 79 10   |
| 3 9  | 3097  | 12 10  | 7 6                                 | 774                           | 23 3                                     | 15 0                                 | 193                            | 45 0   | 30 0                                | 48                             | 81 4  |
| 3 10   | 2964  | 13 1   | 7 8                                 | 741                           | 23 9                                     | 15 4                                 | 185                            | 46 0   | 30 8                                | 46                             | 82 10   |
| 3 11   | 2839  | 13 4   | 7 10                                | 709                           | 24 3                                     | 15 8                                 | 177                            | 47 0   | 31 4                                | 44                             | 84 4  |
| 4 0  | 2722  | 13 6   | 8 0                                 | 680                           | 24 8                                     | 16 0                                 | 170                            | 47 10  | 32 0                                | 42                             | 85 9  |
| 4 1  | 2612  | 13 9   | 8 2                                 | 653                           | 25 2                                     | 16 4                                 | 163                            | 48 8   | 32 8                                | 40                             | 87 2  |
| 4 2  | 2500  | 14 0   | 8 4                                 | 627                           | 25 8                                     | 16 8                                 | 156                            | 49 6   | 33 4                                | 39                             | 88 7  |
| 4 3  | 2411  | 14 2   | 8 6                                 | 602                           | 26 1                                     | 17 0                                 | 150                            | 50 4   | 34 0                                | 37                             | 90 0  |
| 4 4  | 2319  | 14 5   | 8 8                                 | 579                           | 26 7                                     | 17 4                                 | 144                            | 51 2   | 34 8                                | 36                             | 91 5  |
| 4 5  | 2233  | 14 8   | 8 10                                | 558                           | 27 1                                     | 17 8                                 | 139                            | 52 0   | 35 4                                | 34                             | 92 10   |
| 4 6  | 2151  | 14 10  | 9 0                                 | 537                           | 27 6                                     | 18 0                                 | 134                            | 52 9   | 36 0                                | 33                             | 94 10   |
| 4 7  | 2073  | 15 1   | 9 2                                 | 518                           | 28 0                                     | 18 4                                 | 129                            | 53 6   | 36 8                                | 32                             | 95 6  |
| 4 8  | 2000  | 15 4   | 9 4                                 | 500                           | 28 6                                     | 18 8                                 | 125                            | 54 3   | 37 4                                | 31                             | 96 10   |
| 4 9  | 1933  | 15 6   | 9 6                                 | 483                           | 28 11                                    | 19 0                                 | 120                            | 55 0   | 38 0                                | 30                             | 98 2  |
| 4 10   | 1864  | 15 10  | 9 8                                 | 466                           | 29 5                                     | 19 4                                 | 116                            | 55 9   | 38 8                                | 29                             | 99 6  |
| 4 11   | 1810  | 16 0   | 9 10                                | 450                           | 29 11                                    | 19 8                                 | 112                            | 56 6   | 39 4                                | 28                             | 100 10  |

The remaining trees will be at the average distance of 5 ft. All this, whether clearly expressed or not, means that, at this stage of the process, all the trees are to be distant 5 ft., which may be considered as the first thorough thinning. The second thinning should begin when the trees are 16 ft. high averagely, and be conducted in the same regular manner as the former. It may be supposed that about six years will bring them to 25 or 26 feet, and several years more to 30 ft., when the third thinning should begin, to be carried on in the same regular manner as to time, corresponding, likewise, with the calculations of the table.

All extensive woods and plantations, whatever the variation of soil or altitude, when properly thinned, receive shelter in all directions, one part flanking and protecting another from the effects of high winds. At whatever distance trees are planted, the same directions equally apply. Belts and clumps, of small breadth or size, can in nowise be defended from the effect or straining of high winds but by early and accurate thinnings. The lateral branches ought to be shortened, too, and allowed to remain on the trees from the bottom upwards, the same as on the outsides of all plantations, whereby the trees are sheltered, and the neighbourhood converted from bleakness and sterility, perhaps, to warmth and productiveness.

Silver and spruce larch and Scotch firs, on hilly or mountain land, may be allowed to stand closer than the table indicates, as they receive more sun and air in proportion to the acclivities on which they stand. Silver and spruce fir will grow at considerable altitudes, provided the soil be suitable: these must be allowed to stand so close that the under branches may die for want of air. Where timber is alone required, Scotch firs should have a good soil and moderate altitude. Larch is a mountain tree, and will attain to a large size at high altitudes. It is stated that on the north-east side of the Alps the finest trees are found; and in all our mountain districts the same law prevails. The south-west sides of the hills in this district, at 1000 ft. altitude, are destitute of soil; whereas, on the reverse side, larch will attain a large size at 1600 ft. of altitude.

Large plantations cannot be thinned exactly in the regular manner laid down in the table. In these it may sometimes be necessary to let the trees stand closer than there prescribed; and when two or three are closely situated, if there be intervals to give air around, they should stand. Plantations which have not been regularly and gradually thinned lie under great disadvantages. When fully thinned at an improper time, the trees, having overgrown themselves in height, become high without corresponding strength of stem; and, when acted on by high winds, the stem and roots are strained, or, perhaps, the tree

overturned, on the same principle as any weight or force acts on a lever. When wind is of such force as to be equal to a pressure of from 12 lb. to 17 lb. on the square foot, the pine and fir tribe are often so injured that they show symptoms of decay and die. Larch, of all trees, is most susceptible of injury from high winds and the neglect of thinning. Spring should be well advanced, and the trees breaking out into leaf, before the thinning of neglected plantations commences; being partly exposed by the thinning, the action of light and air contributes, in an eminent degree, to the strength and quality of the timber. It is said that isolated oaks, fully exposed to the influence of light, form a more durable timber than the same species which have grown in dense forests: so with other species.

Different opinions undoubtedly prevail regarding the subject of distances in planting, some preferring one distance and some another; the same with respect to the time and modes of thinning: but, being convinced by experience of the utility of my method, I should like to have the reasons of opposition from those who disagree with me.

*Biggar, Sept. 1841.*

---



---

ART. V. *On Pruning Trees.* By PETER MACKENZIE.

WE are informed by old writers that the ancients held the pruning of trees to be of so much benefit that they had a goddess who presided over the operation. Her Ladyship would probably be installed into that office by old Sylvanus, the reputed deity of the woods and forests; and in their deep recesses they could say —

——— “*Lucis habitamus opacis.*”  
[We dwell in shady groves.]

Whether her local habitation was in the *Lucus Petelinus*, or in the groves of Pontus, or in merry Sherwood, or in the *Sylva Caledonia*, I am not informed; but one thing is certain, if ever there were such persons, real or imaginary, they have long since forsaken this part of the world, and gone I know not whither, perhaps to the celestial empire, and left us under the influence of *Discordia*. It is not to be wondered at that our arboriculturists should differ so much both in opinion and practice regarding the cutting of a branch, when they divide and continue to diverge so far concerning the junction of a leaf.

Mr. Cree tells us of the large healthy leaves produced by his system of pruning, and shows us, upon physiological principles, that by means of them a large increase of wood is pro-

duced in the trunk of the tree; but Evelyn and his followers would call them “*phyllomania* which spent all the joyce in the leaves, to the prejudice of the rest of the parts.” But I have no doubt, if these worthies were alive, and placed under Mr. Cree’s tuition, they would soon embrace his doctrines, and would not be long in publishing their recantation to the world. Dr. Liebig, in his *Organic Chemistry*, says: “The power of absorbing nutriment from the atmosphere, with which the leaves of plants are endowed, being proportionate to the extent of their surface, every increase in the size and number of these parts is necessarily attended with an increase of nutritive power, and a consequent further developement of new leaves and branches.” But as every possessor of young plantations has not studied vegetable physiology, and as there are many methods of pruning forest trees before the public, and as some of them appear plausible enough upon paper, it is but right to give them a fair trial in practice. This Mr. Cree is willing to do, and invites his opponents to do the same. I intend to do it upon a small scale with a young plantation of oaks, and will endeavour to do justice to all parties, if I can understand their methods from the descriptions given in the works of those who have written on the subject. If this plan were adopted in various parts of the kingdom, in different soils and situations, it might soon be ascertained which is the best system of pruning, in order to produce the best timber. No doubt many obstacles will stand in the way of the working of such a plan, the chief of these will be prejudice. It is no easy matter for some who have been accustomed to work to one plan, or perhaps no plan at all, to break through their ordinary routine of sawing and hacking. Every innovation is reckoned by them as newfangled nonsense; and an improved method of doing a thing is treated by them with scorn and neglect, until it is forced by ocular demonstration upon their obtuse intellects. It would be desirable to see foresters and, forests keeping pace with the improvement of the times; and whatever may be said respecting trees of other lands, may every lover of his country be enabled to say —

“ Who will, another tree may sing;  
Old England’s Oak for me.”

*West Plean, Oct. 4. 1841.*

---

ART. VI. *Botanical, Floricultural, and Arboricultural Notices of the Kinds of Plants newly introduced into British Gardens and Plantations, or which have been originated in them; together with additional Information respecting Plants (whether old or new) already in Cultivation: the whole intended to serve as a perpetual Supplement*

to the "*Encyclopædia of Plants*," the "*Hortus Britannicus*," the "*Hortus Lignosus*," and the "*Arboretum et Fruticetum Britannicum*."

*Curtis's Botanical Magazine*; in monthly numbers, each containing seven plates; 3s. 6d. coloured, 3s. plain. Edited by Sir William Jackson Hooker, LL.D., &c., Professor of Botany in the University of Glasgow.

*Edwards's Botanical Register*; in monthly numbers, new series, each containing six plates; 3s. 6d. coloured, 3s. plain. Edited by Dr. Lindley, Professor of Botany in the University College, London.

*Maund's Botanic Garden, or Magazine of Hardy Flower Plants cultivated in Great Britain*; in monthly numbers, each containing four coloured figures in one page; large paper, 1s. 6d.; small, 1s. Edited by B. Maund, Esq., F.L.S.

*The Botanist*; in monthly numbers, each containing four plates, with two pages of letterpress; 8vo; large paper, 2s. 6d.; small paper, 1s. 6d. Conducted by B. Maund, Esq., F.L.S., assisted by the Rev. J. S. Henslow, M.A., F.L.S., &c., Professor of Botany in the University of Cambridge.

*Paxton's Magazine of Botany, and Register of Flowering Plants*; in monthly numbers; large 8vo; 2s. 6d. each.

*The Ladies' Magazine of Gardening*; in monthly numbers; 8vo, with coloured plates; 1s. 6d. each. Edited by Mrs. Loudon.

#### Ranunculaceæ.

1622. ANEMONE  
montana Hort. mountain ♀ or 1 ju P Switzerland 1830. D co Bot. gard. 795.

A pretty little plant, apparently a variety of the old *A. Pulsatilla* (*Pulsatilla vulgaris* W.). Imported by Messrs. Loddiges. (*Bot. Gard.*, July.)

#### Berberideæ.

1090. BERBERIS  
Coriaria Royle tanner's ♂ or 4 ju Y Nepal 1835. L co Bot. reg. 1841, 46.

This plant is distinguished from the other Nepal species by its red fruit; and also, Dr. Lindley tells us, "from *B. asiatica* it differs in its finely veined leaves, and larger flowers; from *B. aristata* in its more lanceolate leaves, and shorter and less corymbose racemes; and from *B. floribunda* in its short racemes, large flowers, and much smaller foliage." It is quite hardy, and flowers in June. It may be increased by seeds, which it ripens freely, and which should be sown as soon as ripe; or by layers, which are "two years before they are fit to separate from the parent plant." (*Bot. Reg.*, Aug.)

#### Violariaceæ.

SCHWEIGGERIA Spreng. (*Professor Schweigger*, one of the authors of a *Flora of Erlangen*.)  
pauciflora Martius few-flowered ♂ [ ] cu 2 ... W Brazil ... C co Bot. reg. 1841, 40.  
Synonyme: *Glossarrhen pauciflorus* Dec.

A stove shrub, nearly allied to the violet, and requiring the same treatment "as *ixoras* and other plants of that description." (*Bot. Reg.*, July.)

#### Pittosporaceæ.

MARIA'NTHUS Link. (From *Maria*, Mary, and *anthos* a flower; in honour of the Virgin Mary.)  
caeruleo-punctatus Link, Klotz, et Otto blue-spotted ♂ [ ] or 4 mr B Swan River 1840. S  
Synonyme: *Campylanthera elegans* Hort. [s.p. Ladies' mag. of gard. t. 7.; Bot. mag. 3893.]

A very elegant twiner from the Swan River, which, when well grown, is very ornamental. The best we have seen in flower was at Henderson's

Nursery, Pine-apple Place, Edgeware Road. (*Ladies' Mag. of Gard.*, July ; and *Bot. Mag.*, Sept.)

*Malvaceæ.*

2023. *SIDA* (*Abutilon*)  
*Bedfordiana* Hook. Duke of Bedford's ♀ or 15 n Y.R Brazil 1838. C co Bot. mag. 3892.

A small tree, a native of the Organ Mountains in Brazil, closely resembling *Abutilon picta*, which is also called *Sida* by Sir W. J. Hooker. The present species requires a stove in Britain. (*Bot. Mag.*, Sept.)

*Oxalidææ.*

1414. *O'XALIS*  
*lasiandra* Graham downy-stamened ♀ Δ or 1½ my Pk Mexico 1840. D co Bot. mag. [3896.

This very pretty species of *Oxalis* "approaches most nearly to *O. decaphylla*, or perhaps *O. Hernandezii*; it differs from these, however, in the entire leaflets, the number and appearance of the hairs on their surface, the number of the flowers in the umbel, their colour, the spotting at the apex of the sepals, and in the unequal stamens." Mr. J. M'Nab saw it in Berlin, cultivated as an edging to the walks; and it is there not above 9 in. high, though it reached 1 ft. 6 in. in Edinburgh. (*Bot. Mag.*, Sept.)

11901. fruticosa *Bot. Reg.* 1841, 41.

*Rutaceæ.*

1152. *BORO'NIA*  
*triphylla* Sieb. three-leaved ✱ □ pr 2 Pk New Holland 1840. C s.p Bot. reg. 1841, 47.  
*Synonyme*: *B. ledifolia* Paxton.

This plant, Dr. Lindley says, though called *B. ledifolia* in the nurseries, "has no resemblance to the true *B. ledifolia*; an old greenhouse shrub, with simple leaves, figured years ago in Ventenat's *Plants of Malmaison*, under the name of *Lasiopetalum ledifolium*." The present species is a pretty little shrub, with an abundance of dark pink or rose-coloured flowers. It "requires nearly the same treatment as the smaller kinds of *Diosma*; and, like most hard-wooded plants, should have a light sandy soil, which is rather poor." (*Bot. Reg.*, Sept.; and *Paxt. Mag. of Bot.*, July.)

*Leguminosæ.*

1249. *CALLISTACHYS*  
*linearis* Benth. linear ✱ □ pr 2 o R Swan River 1838. C s.p Bot. mag. 3882.  
*Synonyme*: *C. sordida* Graham.

This species was received under the name of the Crimson Callistachys, but its blossoms are too few and small to warrant the expectations raised of its beauty. It flowers in October. (*Bot. Mag.*, July.)

1943. *BOSSIE'A*  
*tenuicaulis* Graham slender-stemmed ✱ □ or ½ mr Y Van Diemen's Land [Bot. mag. 3895. 1836. C. s.p

A procumbent shrub, with long, slender, straggling branches, and a profusion of yellow flowers. (*Bot. Mag.*, Sept.) Dr. Lindley thinks this species "is too near *B. cinerea*." (*Bot. Reg.*, Oct.)

- disticha* Lindl. two-rowed ✱ □ pr 2 mr Y Swan River 1840. C s.p Bot. reg. 1841, 55.

"A pretty little shrub," raised from Swan River seeds, imported by Captain Mangles. "It has an erect habit, but its branches are slender and weak, and covered with leaves in a two-ranked manner; the latter are ovate, obtuse, not at all hard, and scarcely half the length of the capillary flower-stalks. The flowers are rather large for the size of the plant, and showy." (*Bot. Reg.*, Oct.)

1246. *CHOROZEMA*  
*spectabile* Lindl. showy ♀ □ pr 2 my O.R Swan River 1840 S.C [45.; Bot. mag. 3903. s.p.l Bot. reg. 1841,

A Swan River twining shrub, with long drooping racemes of orange-coloured flowers. It produces seeds in abundance, and cuttings strike readily in silver sand. It is, however, very liable to be attacked by the red spider. (*Bot. Reg.*, Aug.) In the *Bot. Mag.* the following observations are made on the derivation of the word *Chorozema*. "De Theis derives this word from *chōrizō*, to separate; because the fruit is distinctly separated into two equal parts. If Smith's derivation be correct, in the ninth volume of the *Transac-*

tions of the *Linnæan Society*, the word ought to be *Chorozema*, with the *e* short; but *La Billardière* expressly writes it *Chorizema*; and *Sir J. Smith* himself, in a subsequent publication, gives the preference to *De Theis's* derivation, though he thinks it rather alludes to the free or separated stamens, than to the splitting of the fruit." (*Bot. Mag.*, Oct.)

3525. CLIA'NTHUS  
cárneus *Lindl.* flesh-coloured  $\frac{5}{4}$   $\square$  or 6 ap. my Pk [Philip's Island 1840. C r.m Bot. [reg. 1841, 51.  
*Synonyme*: *Streblorhiza speciosa* *Endl.*

This plant is evidently a species of *Cliánthus*, from which it differs principally in the colour of its flowers, which are pink instead of scarlet. It grows best in a rich strong soil, in the free ground, and only requires protection from frost. It is easily propagated by cuttings. (*Bot. Reg.*, Sept.)

1264. MIRBE'LLIA  
floribúnda *Lindl.* many-flowered  $\frac{2}{1}$   $\square$  or 2 mr. ap P Swan River 1838. C s.l.p Paxt. [mag. of bot. vol. viii. p. 103.

This is an evergreen plant, about 2 ft. high, loaded with rich purple flowers, which it retains during the whole of the months of March and April, when gay-flowering plants in pots are particularly desirable. (*Paxt. Mag. of Bot.*, June.)

10627 *speciosa* *Bot. Reg.* 1841, 58.

"There appears to be little difference between this and *M. floribúnda*, except in the very short lucid retuse leaves, deeper flowers, and more hairy calyxes and branches of the latter, which is a Swan River shrub of greater beauty than this." (*Bot. Reg.*, Oct.)

3673. ZV'CHYA  
pannósa *Hort.* wrinkled-leaved  $\frac{5}{4}$   $\square$  or 6 my Dk. C Swan River 1840. C s.l Paxt. [mag. of bot. vol. viii. p. 147.

This very beautiful species is nearly allied to *Z. trícolor*, but "it is readily distinguished by having stronger stems, which are clothed with brown hairs to their summits; shorter, rounder, thicker, and more prominently nerved leaves, the stalks of which are also covered with brown pubescence; a prominent dark-velvety down on the calyxes, and denser heads of flowers." It grows best in loamy soil, and should have abundance of pot room. It looks best trained round a cylindrical trellis. (*Paxt. Mag. of Bot.*, Aug.)

*Rosàceæ.*

1528. POTENT'ILLA  
insignis *Royle* showy  $\frac{3}{2}$   $\Delta$  or 4 su Y Nepal 1840. D co Bot. reg. 1841, 37.

A very splendid species, nearly allied to several of the other kinds imported from the East, which *Dr. Lindley* thinks "may be all one and the same thing, modified by soil and situation." It is quite hardy, and flowers all the summer. (*Bot. Reg.*, July.)

1522. RO'SA  
devoniénsis *Hort.* Devonshire, Paxton's Mag. of Bot. vol. viii. p. 169.

A hybrid rose of "a very vigorous habit, with thick, glossy, dark green foliage, and producing a profusion of flowers." The petals are more thick and fleshy than in roses in general; and the flower, which is very large, is cream-coloured, deepening into a pale yellow in the centre. The whole stock of this rose is in the nursery of *Lucombe, Pince, and Co., Exeter.* (*Paxt. Mag. of Bot.*, Sept.)

*Stylídeæ.*

2581. STYLID'IDIUM  
ciliátum *Lindl.* ciliated  $\frac{3}{1}$   $\Delta$  cu 1 ap. my Pa. Y Swan River 1840. D s.p Bot. mag. 3883.

This curious plant was described in *Lindley's Sketch of the Botany of the Swan River Colony.* The flowers are of a pale yellow, and the whole plant is covered with hairs. (*Bot. Mag.*, July.)

*Compósitæ.*

2413. TITHO'NIA  
ováta *Hook.* ovate  $\circ$  or 4 au Y Mexico 1840. S co Bot. mag. [3901.

A tall showy annual, with coarse foliage and yellow flowers. A native of Mexico, flowering in autumn, and quite hardy in the open air. (*Bot. Mag.*, Oct.)

2323. *HELICHRYSUM* [gard. pl. 9.  
spectabile *G. Don* showy  $\square$  or 2 my. jl Cr Swan River 1841. S co Ladies' mag. of

A very showy robust species, with pale yellow or cream-coloured flowers. Raised by Mr. Hopgood of the Bayswater Nursery, from Swan River seeds imported by Captain Mangles. (*Ladies' Mag. of Gard.*, Sept.)

*Goodenoviæ.*

614. *LECHENAULTIA* [vol. viii. p. 151.  
biloba *Lindl.* two-lobed  $\pi$   $\square$  or 1 jn B N. Holland 1840. C s.p. *Paxt. mag. of bot.*

A pretty little plant from New Holland, remarkable for the contrast afforded by the colour of its flowers, which are a deep blue, to those of the other species, which are scarlet. It requires the same treatment as *L. formosa*. (*Paxt. Mag. of Bot.*, Aug.)

*Ericacææ.*

3173. *ERICA*  
Jacksonii *Paxt. Mag. of Bot. vol. viii. p. 149.*

A hybrid heath, raised by Mr. Jackson of Twickenham, between *E. Irbyana* and *E. retorta*, which begins to flower in July, and continues to September. (*Paxt. Mag. of Bot.*, Aug.)

*Asclepiadacææ.*

3622. *PHYSIANTHUS*  
auricomus *Grah.* golden-haired  $\xi$   $\square$  pr 20 o W Brazil 1836. C s.p. *Bot. mag. 3891.*

This species has smaller flowers than *P. álbens*, and the stems are completely covered with spreading golden yellow hairs. It is a native of Brazil, and probably more tender than *P. álbens*, which grows freely in the open air. (*Bot. Mag.*, Aug.)

*Thymelacææ.*

1197. *DAPHNE* [p. 175.  
japonica *Sieb.* Japan  $\pi$   $\square$  or 2 f. mr Pk Japan 1840. C co *Paxt. mag. of bot. vol. viii.*

This species is remarkable "for the broad yellow margin of its fine ever-green leaves, and for the delicious scent of its pretty flowers." It will probably prove hardy. (*Paxt. Mag. of Bot.*, Sept.)

*Apocýnacææ.*

548. *TABERNÆMONTANA*  
dichotoma *Roxb.* forked  $\uparrow$   $\square$  or 12 s. o W Ceylon 1840. C r.m. *Bot. reg. 1841, 53.*

A fragrant and showy stove tree, "resembling a *Plumièria* in appearance," which flowered lately in the moist stove at Syon. It grows "from 12 ft. to 16 ft. high, with a peculiarly dark and glossy foliage, and delightfully fragrant flowers." (*Bot. Reg.*, Oct.)

*Bignoniacææ.*

1706. *BIGNONIA*  
speciosa showy  $\xi$   $\square$  or 20 ap. my Pk Uruguay 1838. C s.l. *Bot. mag. 3888.*

A showy stove species of *Bignonia*, with pink or pale purple flowers. The stem is woody. It was sent home from Buenos Ayres by Mr. Tweedie, who found it in Uruguay. (*Bot. Mag.*, Aug.)

*Convolvulacææ.*

492. *CONVOLVULUS* 4234 scoparius  
*Synonyme: Rhodorhiza scoparia Webb.*

This plant Mr. Webb makes the type of a new genus, "distinguished from *Convolvulus* principally by its one-celled, and one- or two-seeded capsule; the dehiscence of which, when thoroughly ripe, takes place irregularly from the base upwards, its valves being obliterated." (*Bot. Reg.*, Sept.)

491. *IPOMÆA*  
batatoides *Benth.* Batata-like  $\xi$   $\square$  or 6 su P.C Mexico 1840. C l.p.s. *Bot. reg. 1841, 36.*

This is one of the plants which supply the jalap of the druggists. It is a tuberous-rooted climber, which "seems to require a higher temperature than the common greenhouse, but not so high as the damp stove." The flowers are of a rich purple, with the star of dark crimson. (*Bot. Reg.*, July.)



*Scrophulariæcæ.*

55. SCHIZAN'THUS  
Evansianus Paxt. *Mag. of Bot.* vol. viii. p. 171.

A hybrid Schizanthus, raised in 1839 by Mr. Evans, gardener at New Hall, near Salisbury. It is very pretty, and bears most resemblance to *S. pinnatus*. (*Paxt. Mag. of Bot.*, Sept.)

*Labiatæ.*

76. SALVIA  
confertifolia var. *Bot. Mag.* 3899.

A pretty short-flowered variety of the Brazilian *Salvia*. (*Bot. Mag.*, Oct.)

hians *Benth.* gaping ☼ Δ pr 1 my. jn B Cashmere 1839. D co [1841, 39. Bot. reg.]

A pale blue-flowered *Salvia*, from Cashmere, which is quite hardy in British gardens. It is generally propagated by dividing the root; and, when raised from seed, it does not flower till the second season. (*Bot. Reg.*, July.)

tubifera Cav. tube-bearing ☼ □ or 3 on R Mexico 1840. C [reg. 1841, 44. co Bot.]

This half-shrubby species has much the habit of the old *S. lamifolia* or *amæna*, but "is greatly superior in point of beauty. It forms a bush about 3 ft. high, branching, and well covered with leaves;" the branches terminating in long drooping racemes of slender purplish pink flowers. It requires a greenhouse, as it flowers in autumn and winter. (*Bot. Reg.*, Aug.)

*Acanthæcæ.*

3659. STROBILANTHES  
sessilis *Grah.* sessile ☼ □ pr 4 o Li India 1833. D co Bot. mag. 3902.

This stove perennial was sent to Great Britain in 1833 by Dr. Lush of Bombay. (*Bot. Mag.*, Oct.)

*Orchidæcæ.*

254. EPIDENDRUM  
Grahami *Hook.* Dr. Graham's £ □ or 2 s B.Y.R Mexico 1840. D p.r.w [3885. Bot. mag.]

This species belongs to the group *Encyclium*, and is a native of Mexico. (*Bot. Mag.*, July.) Dr. Lindley thinks it the same as *E. altissimum*. (*Bot. Reg.*, Sept.)

calochellum *Hook.* beautiful-lipped £ □ or 2 s.o B. Y Guatemala 1839. D [mag. 3898. p.r.w Bot.]

Another species belonging to the group *Encyclium*, greatly resembling the preceding species. (*Bot. Mag.*, Oct.)

2569. ANGRÆCUM  
bilobum *Lindl.* two-lobed £ □ or ½ s W Cape Coast 1830. D p.r.w Bot. reg 1841, 35.

A pretty epiphyte with pendulous racemes of fragrant white flowers, slightly tinged with pink. It is a native of Cape Coast. (*Bot. Reg.*, July.)

2523. CYMBIDIUM  
pubescens *Lindl.* pubescent £ □ or 1 o C.G.Y Sincapore 1834. D p.r.w [1841, 38. Bot. reg.]

A pretty species from Sincapore, with drooping racemes of crimson, green, and yellow flowers. (*Bot. Reg.*, July.)

2559. ERIA.  
armeniaca *Lindl.* apricot-coloured £ □ or 1 o O.C Philippine Isles [Bot. reg. 1841, 42. 1384. D. p.r.w]

A very showy plant, from its bright orange bracts, and crimson flowers. "It should be potted in turfy peat or sphagnum, and grown in the warmest end of a damp stove." (*Bot. Reg.*, Aug.)

ODONTOGLOSSUM  
pulchellum *Bate.* pretty £ □ or 1 f W.Y.C Guatemala 1840. D p.r.w [48. Bot. reg. 1841,]

The most striking features in this species "are the long thin pseudo-bulbs, the very narrow grassy leaves, and the singular protuberance at the base of the white lip. This protuberance is deep yellow, spotted with crimson, very fleshy, fine, and shining; and it is almost horseshoe-shaped in front, while it is distinctly three-lobed behind, in consequence of two deep depressions." This is one of the *Orchidæcæ* which "require less heat than is generally kept in our moist stoves." (*Bot. Reg.*, Sept.)

2547. *DENDROBIUM*  
*discolor* Lindl. dull-coloured £ ☒ or 4 o Y.B Java 1838. D p.r.w Bot. reg. 1841, 52.

A singular plant, "with stout erect stems, 4 ft. high, swollen in the middle, and with terminal racemes of about sixteen dingy yellowish brown flowers, as much curled and wavy as those of a *gloriösa*." (*Bot. Reg.*, Sept.)

macrophyllum Lodd. broad-leaved £ ☒ spl 2 ap Li Manilla 1838. D p.r.w <sup>[mag. of bot. vol. viii. p. 97.]</sup> Paxt.

A most splendid plant, with thick pendulous stems, thickly covered with leaves, and of nearly the same size throughout. The leaves are thick, short, and broad, of a very deep green, and quite sessile. The flowers are very large and showy, and they are produced from twenty to thirty on each drooping stem. The plant should be grown on a block of wood. (*Paxt. Mag. of Bot.*, June.)

2542. *COELOGYNE* 29732 *cristata* Bot. Reg. 1841, 57.

*GALEA'NDRA* Lindl. (*Galea*, helmet, *anēr*, stamen; from the helmet-shaped crest of the anther.)  
*Devoniäna* Lindl. Duke of Devonshire's £ ☒ 2 ap. my W. Pk S. America 1840. D  
 [p.r.w Bot. No. 231.; Paxt. mag. of bot. vol. viii.]

This very handsome orchidaceous plant was first figured in Dr. Lindley's *Sertum Orchidaceum*, and named by him in honour of the Duke of Devonshire. "It produces large round stems, terminated by elegant half-drooping foliage, from amongst which the lovely flowers are protruded in upright racemes. They are remarkable for the size and elegant markings of their labellum." (*Paxt. Mag. of Bot.*, Aug.; and *Botanist*, Aug.)

3516. *BURLINGTONIA*  
*rigida* Lindl. rigid £ ☒ pr 1 ap Pk. W ? 1838. D p.r.w Paxt. mag. of bot. vol. viii. [p. 193.]

"The plant, consisting of several pseudo-bulbs, is growing in a pot filled with heath soil and potsherds; and from each of the pseudo-bulbs a long, rigid, wire-like stem ascends, developing a new bulb at its summit," from which a quantity of white roots descend. The next year the same process takes place; and, when the stems are trained to a cylindrical trellis, the effect is very singular. (*Paxt. Mag. of Bot.*, Oct.)

2540. *ONCIDIUM*  
*monóceras* Hook. one-horned £ ☒ pr 2 ja Y Rio Janeiro 1839. D p.r.w Bot. mag. 3890.

A small-flowered species of *Oncidium*, chiefly remarkable for a solitary horn-like process on the upper lip, curved upwards, and almost as long as the lip itself. (*Bot. Mag.*, Aug.)

#### Tulipacææ.

1017. *TULIPA* 29311 *pätens* Agardh.  
*Synonyme*: *T. tricolor* Ledeb., Bot. Mag. t. 3887

1016. *LYLIUM* 30172 *speciosum* var. *älba* Paxt. Mag. of Bot. vol. viii. p. 127.

## MISCELLANEOUS INTELLIGENCE.

### ART. I. General Notices.

*SENDING Home Seeds from warm Climates.*—I may just observe that, in respect to packing seeds, it has been found that they should neither be put in the hold of the vessel, nor suspended immediately under the roof of the cabin, as in both situations they are liable to be affected by the steam of the ship. If they are suspended midway between the floor of the cabin and the ceiling, they have most chance of not being injured by the steam of the vessel. This was told me in York about a week ago by Mr. James Backhouse, who has been between nine and ten years travelling in Australia and Africa, and has sent home a great many seeds to his brother, the eminent York nurseryman. Mr. Backhouse further observes that the best mode of sending home seeds from warm climates is by post.—*T. S.* Oct. 5. 1841.

*The Solar Ray*, or beam of light, may be divided or decomposed into light, heat, and colour. Heat and electricity are now most generally supposed

to be similar, or perhaps identical, in their nature. The beam, or ray, of light has no sensible heat high up in the atmosphere, and it is only the refraction and reflection of the atmosphere and other bodies which make it sensible.—*R. May*, 1840.

*Oil-Paper Frames*, or hand-frames covered with oil-paper, generate more heat than glass frames, or hand-frames glazed with glass, for reasons which may be deduced from the facts stated in the foregoing paragraph.—*Idem*.

*The Potting-bench Instrument*, I find a most useful article for mixing different moulds, and also for potting. The form is such that it will convey mould into the smallest pot. It is made of sheet iron. It is a half-cylinder, with a piece on the top as a brace, and a handle standing up, so as to clear the hand well from the potting-bench; in a word, if I were to say it is a coal-scuttle in miniature, with a handle at the end, you have a full description of it. Mine is 7 in. long,  $2\frac{1}{2}$  in. deep at the handle, and 4 in. over at the top. The handle is 5 in. long. The edges of the iron are turned up to make it strong, except the fore part for sliding along the bench.—*J. D. Parkes. Dartford Nursery, May 12. 1841.*

*A Forcing-House which may be applied to various Purposes.*—I would have the back part of the house heated by a row of hot-water pipes, the pipes to run along the back of the path; I would have two stop-cocks in the hot-water pipes immediately at their entering the house from the boiler, by which means the water in the pipes could be cut off from that contained in the boiler at pleasure; at the same time I would insert a pipe in the top of the boiler, and bring it into the house where the hot-water pipes enter, and run it closely under the hot-water pipes. I would have a few holes perforated in this pipe, so that the steam would escape into the house, and thus the boiler would serve two purposes. I feel confident there is nothing better for promoting the growth of pines and cucumbers than steam, if cautiously used. On the top of the hot-water pipes I would have dishes, but the one to be in conjunction with the other, in such a manner, that by a tap running into one dish at the end it would fill the whole of the dishes.

As to the heating of the front of the house, I would have a trench made for a lining of dung, and have boards to fit neatly over the top, so as to keep the dung out of sight. The thickness of the front wall I would have about the length of a brick, and it should be pigeon-holed from top to bottom. I would also have a vacuity inside, betwixt a slate flag and the front wall; the flag to be about  $\frac{1}{2}$  in. in thickness, and built from bottom to nearly the top of the front wall, in order that the heat of the dung might act against it. I would also have one row of ventilators fixed on the slates, so as that I could either admit the steam from the dung into the house or not at pleasure. In some cases the dung might go round all the house, except where the door and boiler might happen to be; and when the dung was in good order, the fire might be at that time altogether discontinued. All the cucumbers that are grown here are grown in a house; and I feel confident no one would trouble himself with frames, if he saw the great quantity of fruit that is grown here all the year round.—*Charles Ewing. Knowlesley Hall Gardens, May 3. 1840.*

*An Ice-House under Rockwork.*—I lately made a piece of rockwork upon a spot that is very limited, where space is of the greatest consequence, and materials to constitute bulk not easily procured. Under these circumstances, I made, as it were, a framework of arches, whereby much useful room was gained, and considerable materials saved. Others so situated may profit by the hint. I do not send a sketch of the ground plan, as the dimensions may be entirely suited to the nature of the spot operated upon. The height within, however, ought not to be less than 7 ft., for the convenience of performing any operations that may be necessary.

Such a place as that represented might, with great propriety, be made the entrance to an ice-well, when the materials excavated would do much towards forming the erection outside. Forming the interior (when convenient) into

cellars for coals or other matters would also answer the same purpose. The structure in question is not sunk lower than the general level of the surface, being originally intended to preserve roots, or stow away lumber: but the uniform and moist atmosphere maintained within led me to think it well suited to grow mushrooms, and it has been found to do this perfectly; as a bed made up in September is in bearing now, and has produced mushrooms of excellent quality. As some part of this place is only separated from the external air by a 14-inch wall, the severe weather in winter checked the growth for a short time, but did not prove otherwise hurtful, as it immediately commenced upon the introduction of some hot dung to raise the temperature, which in a structure so confined is easily done. Had this precaution been taken in time, no check whatever need have been felt. Such a place admirably suits this purpose during summer, as the great body of surrounding material keeps every thing inside uniformly cool. Were it upon a scale that would be too extensive, it would require air-tight divisions, to confine the humid and somewhat heated air surrounding the mushrooms, which would prove injurious to most things that might be deposited there. — *N. M. T. Folkstone, May 27. 1841.*

*Economical Planting.* — For planting trees in plantations Sir E. Stracey's Rackheath subsoil plough (see New Series of *Brit. Farm. Mag.*, Nos. 2. and 7.) far exceeds digging, as, by proper management, the soil may be broken 2 ft. deep at a fourth of the expense of digging. (*Brit. Farm. Mag.*, vol. iii. n. s. p. 145.)

*The Quince* is a fruit prized in North America next to the apple; the great demand for it is for preserving: "but for drying, to mix with dried apples or peaches, the quince possesses a value unrivalled by any other fruit; the superior flavour communicated by them to pies can only be appreciated by those who have tasted of their excellence when used in that way. (*Yankee Farmer*, May 8. 1840.)

*Preserving Currants on the Bushes till Christmas.* — At Bury Hill, the seat of Robert Barclay, Esq., they have a way of preserving currants till Christmas, in a high state of preservation. A plantation of red and white currant trees, occupying a space of about 20 ft. square, is enclosed within a close paling 6 ft. high; the trees are trained as espaliers. A strong beam rises from the centre of the plantation, higher than the paling, from which rafters diverge in all directions, and rest on the paling, to support a roof of thin white canvass, which is fastened down all round the paling. Several openings, about 6 in. square, are left at the top of the paling for the admission of air, and are filled up with mouse-trap wire, to prevent the intrusion of insects. As soon as the fruit is gathered, the canvass is removed, and the trees exposed to the elements; they have stood in this state for four or five years, and have always borne a good crop. — *M. L. Dorking Common, Aug. 29. 1841.*

*Bròmus praténsis and Festuca U'rii.* — Your account of the *Bròmus praténsis*, in the very agreeable sketch of your visit to Paris, p. 297., induced me to beg a friend, who was returning to England, to bring me a couple of pounds of the seed from M. Vilmorin. Our soil here, as your recollection may suggest to you, requires an herbage capable of enduring aridity; and I hope I may find the *Bròmus praténsis* useful in that respect. I have tried some of Dr. Ure's fescue grass (*Festuca U'rii*), and, as far as a trial upon a very small scale can prognosticate, it bids fair to succeed. — *H. L. L. June, 1841.*

*Asphalte.* — I am an admirer of asphalte, like yourself, and I read your extract from Dr. Ure, respecting the possibility of producing it artificially, with great interest, particularly as we have the two main constituents, sand and chalk, so near at hand. Another friend of mine, also recently returned from Paris, has given me a receipt for compounding it, which he met with in a French work, and I enclose a copy as you might like to see it.

*Receipts for preparing Artificial Asphalte.* No. 1. Take 18 parts of mineral pitch and 18 of rosin (this seems requisite to give it the hardening quality), put them into an iron pot for about twenty minutes over a fire; they will boil, and

must be kept boiling a little. Then add 60 parts of sand, 30 of small gravel, and 6 of slacked lime.

No. 2. Take 1 part of mineral pitch, 1 part of dry rosin, 7 parts of chalk, 2 parts of sand, and boil them as before — *H. L. L. June, 1841.*

## ART. II. Foreign Notices.

## ITALY.

*GARDENING.* — In my last, dated the 9th of January (see the Magazine for March 1841, p. 182.), I promised to send you a list of the plants introduced into Lombardy during the past year (1840). This I am now enabled to do, through the kindness of Signor Casoretti, the indefatigable director of the garden of the Villa Traversi, at Desio, who favoured me with the following catalogue, the greater number of the species in which he himself introduced.

- |  |  |
|--|--|
| <i>Æschynánthus coccíneus.</i>   | <i>Hibíscus spléndens.</i>                                 |
| <i>Alstroëmèria Barclayàna, Néflü tricolor.</i>  | <i>Hemerozállis Sieboldiàna.</i>                           |
| <i>Amphícome argùta.</i>   | <i>Hotéfa japónica</i>                                     |
| <i>Andrómeda angústa, spec. nova,</i>  | <i>Illícium religiòsum.</i>                                |
| <i>Drummóndi tetragòna.</i>  | <i>Jasminum, species nova from China.</i>                  |
| <i>Anigozánthos coccínea.</i>  | <i>Leycestèria formòsa.</i>                                |
| <i>Vánda Gomèsii.</i>  | <i>Lílium exímium, japónicum, superbum.</i>                |
| <i>Azàlea índica var. plures, póntica hyacinthiflòra.</i>  | <i>Liriodéndron Tulipífera heterophýlla.</i>               |
| <i>Bérberis orientális, spec. nova, Buenos Ayres.</i>  | <i>Magnòlia Hartierens ? rotundifòlia ?.</i>               |
| <i>Byttnèria brasiliènsis.</i>   | <i>Mahònia fasciculàris, glumàcea.</i>                     |
| <i>Caméllia j. Aimable d'Amérique, Cunnighàmia, Perfection, Henry Favre, Meteor, Nicólsii, Palmer's perfection, peregrina, Prátt's seedling, Striped majòr, Thompsóniàna superba, Wallichii, Washington, Weárdii, and many others.</i> | <i>Mammillària crinàta, echinàta, glochidiàta, ténuis.</i> |
| <i>Cèreus Hitchínsii híbridus, Hitchínsii speciòsus múltiplex, oxygònus, pentálophus.</i>  | <i>Mandevíllea suavèolens.</i>                             |
| <i>Chorózema vàrium.</i>   | <i>Mùsa Cavendíshii, Dácca.</i>                            |
| <i>Clématis flórida Siebóldii D. Don, cærùlea Lindl.</i>   | <i>Nelúmbium álbum, thibetiànum.</i>                       |
| <i>Cobæa stipulàris.</i>   | <i>Nymphæa Lótus, rùbra, versicolor.</i>                   |
| <i>Crinum angústum.</i>  | <i>Opúntia glaucophýlla, imbricatà, Kleinià.</i>           |
| <i>Dacrýdium elàtum.</i>   | <i>Pæonià tenuifòlia fl. plèno.</i>                        |
| <i>Deùtzia corymbòsa, sanguínea.</i>   | <i>Pentstèmon frutéscent, bicolor, gentianòides.</i>       |
| <i>Diánthus spléndidíssimus.</i>   | <i>Phlòmis Russelliàna.</i>                                |
| <i>Epimèdium violàceum, macránthum.</i>  | <i>Plumièria angustifòlia.</i>                             |
| <i>Epiphýllum rhómbeum.</i>  | <i>Potentilla Hopwoodiàna.</i>                             |
| <i>Eriostèmon buxifolius, cuspidàtus.</i>  | <i>Pronàya élegans.</i>                                    |
| <i>Erythrina pùmila.</i>   | <i>Rhododéndron arbòreum, ten new varieties.</i>           |
| <i>Euphórbia melofórmis, spléndens.</i>  | <i>Ribes speciòsum, inèbrians, muscòsum.</i>               |
| <i>Fúchsia corymbiflòra, formòsa, élégans, fúlgens, grandiflòra, péndula, salicifòlia, versicolor.</i>   | <i>Sálvia patèns.</i>                                      |
| <i>Gésnera oblóngà.</i>  | <i>Solándra guttàta.</i>                                   |
| <i>Grevíllea Manglésii, robústa.</i>   | <i>Tweèdia cærùlea.</i>                                    |
| <i>Hæmatóxylon campechiànum.</i>   | <i>Thysanòtus elàtiòr.</i>                                 |
|  | <i>Tradescántia grandiflòra, spléndens.</i>                |
|  | <i>Verbèna, five new varieties.</i>                        |
|  | <i>Wistària Backhousiàna, floribúnda.</i>                  |
|  | <i>Yúcca abyssinica, fláccida.</i>                         |
|  | <i>Xanthòsia rotundifòlia.</i>                             |
|  | Besides a great many more mentioned in my last letter.     |

You may see from this that the love of plants is greatly increasing in Lombardy. But I have not told you of the mania in Lombardy for Roses, and particularly for the numerous varieties of the tea rose, the Bourbon rose, and the rose perpétuelle ; also for the *Viola tricolor*, the *Aurícula*, and the *Dahlia*. He who possesses the smallest garden must have his dahlias, and on entering one of these, the first questions are : “ Where are your dahlias ? Where are your roses ? ” Signor Casoretti introduces every year a great variety of the best dahlias, and particularly those registered in the *Gardener's Gazette* as having obtained prizes. They cost him annually the sum of 1200 francs ; and to give you an idea of the increasing taste for this plant in Lombardy, it is sufficient to say, that in 1835 they only cost him 200 francs.

Signor Casoretti now possesses more than 450 varieties of Camellias. Fifteen years ago, a camellia which he had was looked upon as a wonder, and now even in spring you see the balconies of persons of moderate fortunes decorated by them. Fifteen years ago, a variegated *Camellia japonica*, about 2 ft. in height, cost 15 francs ; and now a plant of the same kind and size may be had for 4 francs. You cannot imagine what a demand there has been for the last four or five years for the flowers of this plant, during the carnival, to ornament the heads of the dancers. They are also in great repute at parties in the capital, where they have excluded other flowers, and so much so, that the sum of 4 francs is sometimes given for a single flower. My friend Signor Casoretti showed me the other day, that the annual entry for camellias, fifteen years ago, was about 200 francs ; and he calculates that the entry at present, in consequence of the great importation from France, amounts to 6500 francs.

I must now tell you of a *method of multiplying camellias*, which has been in use here since 1830, and which I consider to be a much easier and more useful way than that hitherto practised by inarching or cuttings, and which may serve as an answer to the query of an Amateur in the *Gardener's Gazette* of the 23d of January of the present year. I take from a strong-growing camellia some of the roots which are about the thickness of a common writing quill, and then cut them in pieces, taking care to leave some of the fibrous roots on each portion, without which it would die. I then take a small piece of a twig of the variety I wish to propagate, furnished with one bud, and cleft-graft it on the portion of root. I plant it in a suitable-sized pot, and then put it in a stove at a temperature of 12° Reaum. (59° Fahr.), shaded from the sun, and covered with a white bell-glass. In the course of a few days my grafts begin to vegetate, and I have seen some of them put out a shoot 6 in. long in the course of a month. A great advantage of this method of grafting is, that it can be performed at all times of the year (except, however, at the time when the *Camellia* is in full vegetation) ; and, by only having one bud of the variety you wish to propagate, you are sure to have a new plant. It is also more economical, as the stocks on which the camellias are usually grafted are a foot in height, and cost about a franc apiece. This method has been practised by me, as well as by my friend above mentioned, and is, we are convinced, the best in use ; and, when the operation is performed with care, the loss cannot amount to more than four in a hundred.

Neither is the art of artificial fecundation at a stand still among us, as I see this year various camellias raised from seed which Signor Casoretti considers perfectly beautiful, and two of them form the chief ornament of his valuable collection.\* He has called the one *Soulangeana plenissima*, and the other *Taverna*,

---

\* This is the case, notwithstanding what the Abbé Berlèse has stated respecting the camellias in the gardens of Milan, in his *Monograph on the Genus Camellia*, 2d edit. revised and corrected, pp. 65, 66. You will see that this author has been mistaken in his information on the subject ; as the *C. Nassiniana di Lechi*, the *Sacco di Tagliabue*, the *Sacco nuova di Sacco*, the *Barai di Casoretti*, the *Duchesse d'Orleans di Sacco*, the *Traversi di Casoretti* (these have all perfect flowers, and the others have the petals fasciculated (*fascicolate*))

in honour of the lady of the excellent Count Lorenzo Taverna, a distinguished agriculturist and chemist. Two varieties were obtained from *Pæonia Moutan rosea*, fecundated with the pollen of *P. tenuifolia*, and, last spring, were the admiration of horticulturists. The flower was equal in size to that of the parent plant, but fuller; and one of them of so rich a carmine colour, that it was impossible to look at it while the rays of the sun were upon it. It is therefore not inferior to the *Verbena chamædrifolia superba* in colour.

A few days ago, being in Bergamo, a town in Lombardy, about ten leagues north-east from Milan, which principally owes its opulence to the trade in silk, considered the best in Italy, next to that of Piedmont, I went to see the small garden of the Count Giovanni Batta Maffesi, a man of great learning, and much respected for his virtues. I saw in his stove *Caryota urens*, *Zamia pungens*, 1 ft. 3 in. in diameter; *Z. horrida*, 1 ft. in diameter; *Strelitzia juncæa* in flower, lanceolata, and *reginæ*; also a respectable collection of camellias; *Araucaria imbricata*, 10 ft. high, which, with *A. brasiliæna*, I advised to be planted in the open air, as the climate is mild and salubrious. I saw the *Nandina domestica* growing vigorously, 8 ft. high, in the groves in the open air; also *Olea frâgrans*, only 8 ft. high; *Magnolia acuminata*, 36 ft. high, and 8 in. in diameter; *M. grandiflora*, and *M. glauca*; *Callistemon lophanthus*, 6 ft. high, protected in winter by a simple covering of straw, to prevent radiation (a proof of the mildness of the climate); *Ligustrum japonicum*, 18 ft. high, and 10 in. in diameter, the most beautiful specimen I ever saw; *Wistaria floribunda* and *Backhousiana*, this is the first time the latter has flowered; *Photinia serrulata*, 10 ft. high, and 6 in. in diameter; *Sterculia platanifolia*, 10 ft. high, and 1 ft. in diameter; *Rhododendron arboreum*, *ponticum*, and *maximum*. — *Giuseppe Manetti. Monza, Aug. 21. 1841.*

#### AFRICA.

*On the Malaria of the Western Coast of Africa.* — Although it may, apparently, be a little removed from the general routine of subjects immediately connected with gardening, this subject is of such vital importance, more especially to the enterprising individuals who risk their lives in the prosecution of botanical researches, that I cannot refrain from noticing the important discoveries recently made, for which we are indebted to the zeal and ability of Professor Daniel, in whose hands the data from which they have been made were placed by the Board of Admiralty.

Those who have visited the pestiferous shores of Western Africa have long been aware of the existence of a dismal and sickening stench, which assails the nerves on entering the deltas of the rivers in that part of the world. Singular as it may appear, it is only very lately, and incidentally, that the true cause and consequence of this smell have been discovered. It is proved beyond a doubt, by the experiments of Mr. Daniel, founded on analysis of the waters which have been conveyed to England, that it is occasioned by the action of decayed vegetable matters, which are conveyed in enormous quantities by these rivers

---

and the flowers globular), the Manetti di Casoretti, the Bellini major di Casoretti, la Castioni di Variselis, la Vestalis di Casoretti, la Santiniana di Casoretti, la Monti di Casoretti, and a hundred others, have all been raised in the garden at Milan, and by Milanese gardeners. In speaking of this work by the Abbé Berlèse, allow me to call your attention to what he says in p. 51., on raising the *Camellia* from seed, viz.: "Ces graines restent souvent deux ans sans lever, et quelquefois elles levent dès la première année." ("These seeds often lie in the ground for two years without vegetating, and sometimes they spring up the first year.") Now, with us the *Camellia* vegetates after having been two or three months sown (we sow the seed as soon as it is gathered, because, being of an oily nature, it soon spoils if exposed to the air); and those that remain longer in the ground are imperfect or badly treated, and the plants produced from such seed are badly grown, and finally perish.

in the rainy season. These vegetable matters act on the sulphates contained in the sea water, and by their action sulphuretted hydrogen is evolved, to which in great part, beyond all doubt, the insalubrity of these shores is to be attributed. The extent of sea over which this fatal cause predominates is estimated at 40,000 square miles; and it no doubt accounts for the facts mentioned, but for which no reason was assigned, in the invaluable reports lately published by government, and in which the dry igneous rocks of parts of that dreadful coast appear equally fatal to health as the marshy and moist districts. It also confirms what I have long been convinced of, that the dread effects of the mangrove, sleeping under which is always considered to produce inevitable death, are caused, not by the tree itself or its exhalations, as is the common belief, but by the local nature of its habitat, which is the saline estuaries, just where the chemical causes above mentioned are the strongest in their operation.

Like so many other discoveries, this very important one has been owing to collateral circumstances. The evolution of the gas, and the impregnation of the water by it, are most fatal to the copper on ships' bottoms; and the investigation of this comparatively unimportant object of economy appears to have led to the knowledge of the true cause of the enormous loss of life which has attended all our operations on that coast. There is no question that the subject ought to be, and will be, followed up; as it can easily be done by orders sent to the different foreign stations, to collect the waters on those coasts which are well known to be the most insalubrious. I may point to the Mozambique country, on the east coast of Africa, some parts of which appear to be, by the effects on men and officers employed there, if possible more fatal to human life than those of the western coast. In the west, the whole coast of Guiana, from Cayenne and the Oyapoh to the mouth of the Orinoco, should be examined; and the Bay of Honduras, as well as the coast of Vera Cruz, and the opposite coast of Acapulco; and parts of the sea opposite the rivers of St. Domingo, which, in the rainy season, convey vast quantities of trees and other vegetable matter to the ocean. There is no doubt that the same cause operates in many places, in fact, almost every where, though with less intensity as you approach the arctic circle; and that the sea water is every where more or less affected by the influx of quantities of vegetable matter brought down by the rivers at particular seasons, though happily in the temperate zone we are comparatively free from its noxious effects. In the future researches of the learned professor we trust to be informed of the effect of heat in producing these exhalations; and, as successive observations give the requisite data, we may find that the same quantity of vegetable matter, or nearly so, in one latitude may be almost innocuous, whilst in another it may produce the fatal effects unhappily found in the countries recently examined.

The antidote recommended to this fatal poison is chlorine, the effect of which, as is well known, is to completely neutralise the sulphuretted hydrogen; in the words of the professor, "they cannot coexist;" and orders have been given to furnish the expedition lately sent to the rivers of Africa with an abundant supply of this substance. I hope and trust it may be beneficial, but it is extremely difficult to deal with an entirely infected atmosphere, to which both men and officers must be exposed. It is probable, by fumigating the lower parts of the vessels in which the men sleep, a great deal of good may be done; and that by breathing a comparatively pure atmosphere during the period of repose, the constitution may be better fitted to withstand the fatal miasmata whilst exposed to them during the other parts of the day. To those who have to sleep in marshy districts, where it is possible to effect it, there is no question that huts should be resorted to and fire kept, as well as the chlorine fumigation now recommended and furnished by government to the African expedition; and that the South American method of sleeping in hammocks suspended to trees, as high as possible from the ground, should always, if possible, be adopted.



It has been stated that the present important discovery applies more especially to estuaries, and that the theory of it proceeds on the combination of vegetable matter with the sulphates contained in sea water. According to this view, the cause ought to diminish as we quit the coast, and advance into the country. It is on this principle the examination of the interior of Africa is calculated, and there can be no doubt of the truth of the hypothesis to a certain extent; but there are other parts of the world where the case is inverted, as I shall probably show in another notice on this important subject. — *W. Sept. 12.*

## NORTH AMERICA.

*American exploring Squadron.* — Mr. Nuttall has returned from Washington city, after arranging forty boxes of plants sent home from the American exploring squadron, which had been collected at Madeira, Rio de Janeiro, Cape de Verde Islands, Patagonia, Terra del Fuego, Chili, coast of Peru down to Callao, the Figeo Islands (having made friends with the inhabitants), Navigation group, and coast of New Holland. He says that the plants are preserved in the best manner, and will be an immense acquisition to botany. Many more boxes are expected from the squadron, the result of the industry of the scientific men on board, and of the officers, who aided zealously the labours of the botanists. The collection of ornithology is also very great. — *J. M. Philadelphia, Aug. 3. 1841.*

*Supposed new Cherry.* — Some months since I sent you a description of a new cherry, from the Journal of the late C. S. Rafinesque, and said to have been brought by Lewis and Clarke from the Organ Mountains; but upon comparing it to-day with specimens of European cherries in the valuable herbarium of the Academy of Natural Sciences of Philadelphia, with Mr. Nuttall, it would seem to be the *Cerasus Mahaleb* of the Old World. I must say, however, that the fruit is not hard, as asserted by Gerard, nor is there any scent in the wood, fruit, flowers, or leaves, at least to the degree quoted from him in the *Arboretum Britannicum*, chap. 42. p. 707. The leaves of a branch plucked two days since have a slight peach-leaf flavour. There are two trees of the cherry in Washington Square. — *Idem.*

*Ailántus glandulosa.* — I regret to say that this beautiful tree, which ornaments and shades the pavements of this beautiful city, is very subject to a decline for a season, and to death the next year. The morbid cause is to me inexplicable. One, two, or more, in a row are thus affected, while others remain in full vigour. The picturesque arrangement of the branches and leaves, the rapid growth of the tree, and its exemption from insects, render it a great favourite. I am very anxious to discover a preventive or remedy for the disease. Is the tree subject to the same affection in England? — *Idem.*

*Machira aurantiaca.* — In addition to the useful purposes to which this tree is applied and of which it is capable (Vol. VII. p. 508.), I may now mention that of *hedges*, for which it is admirably adapted by reason of its very rapid growth, and the sharp thorns, 1 in. or more in length, placed alternately along the branches. A branch was recently sent me that grew 5 ft. this season. If properly trained and trimmed, I think it would answer well, and defend an enclosure against any animal. An experiment, I am told, is now in progress near this city, to test its capability for this purpose. — *Idem.*

*New Edition of Michaux's Sylva.* — Mr. Nuttall is now engaged in preparing this work, which is to be published by Mr. Judah Dobson of this city. The plates of this valuable work were purchased by the late patriotic William Maclure in Paris, and sent to Harmony, state of Illinois, the seat of Robert Owen's famous experiment for reforming mankind. — *Idem.*

*New Edition of Michaux's Sylva.* — I received a letter from Mr. Nuttall a day or two ago. He is still engaged in preparing his new edition of Michaux's *Sylva*

for the press. He will add an entire volume of trees that were omitted by Michaux, with plates equal to those of the original work. Dr. Gray has just returned from a pretty long journey into the mountains of North Carolina, an account of which will appear in the next number of *Silliman's Journal*. — *John Torrey. New York, Aug. 9. 1841.*

### ART. III. Domestic Notices.

#### ENGLAND.

*THE Greenhouses in the Wakefield Nursery.*—In your Magazine for June 1836, No. 85. p. 312., there are a perspective view and a short account of a range of greenhouses belonging to Mr. Barratt, nurseryman, St. John's, Wakefield. Having been favoured by the proprietor with an account of the cost of these houses while they were erecting, I urged him to send you a sketch, with the details of the cost, which I was in hopes would have been laid before the public; because I know that a great many persons are prevented from indulging themselves with a very rational luxury, from an indefinite fear of the expense of a plant-house of the commonest kind; and that others, who require that elegance should be united with utility in an erection of this kind, are not aware for how small a sum a very beautiful greenhouse may be built. Having explained my views to Mr. Barratt, I must do him the justice to say that he entered most fully into them, and with great readiness furnished me with all the details, which I shall proceed to give you. The walls of these houses are built of brick, 9 in. thick; the roof of the long house is constructed in the first instance of iron ribs ( $\frac{3}{8} \times 1\frac{1}{4}$  in.) 3 ft. 7 in. apart, strengthened by two horizontal bars ( $\frac{1}{2}$  in. square) 2 ft. 4 in. apart; between the first ribs every 6 in. are fixed deal ribs ( $\frac{1}{2}$  in. square), which are bent to the proper curve, and tied to the horizontal bars. Upon these the glass is laid, and thus forms a complete and entire surface of glass of great strength. The ventilation is effected by openings in every fourth sash, 1 ft. 4 in. deep, and the whole width of the sash. (See the fig. in p. 313. Vol. XII.) The whole expense of this long house, 85 ft. long by 10 ft. 6 in., was only 170*l.*, that of the dome, 41*l.* You will see that there is a walk 3 ft. wide, with a border for plants on each side, 85 ft. long, and a square, surmounted by a very handsome dome, 14 ft. 6 in. wide, the whole cost of which is under 220*l.*; and when it is filled with Mr. Barratt's very numerous collection of calceolarias in full bloom, or with his still more numerous collection of beautiful fuchsias, it not only leaves at an immense distance the unsightly "lean-to" houses that nurserymen usually erect, but far surpasses in real beauty many conservatories that have cost twenty times the sum. The first half only is at present completed, as shown in the perspective view. The other half is now covered with a span roof, formed of the lights from Mr. Barratt's former garden; and though certainly not so picturesque a house as the curvilinear one, is still very ornamental, and of course less costly. I feel sure that a house on this plan, 18 ft. long, and 11 ft. wide, might be finished for less than 25*l.* These papers will be brought to you by Mr. Barratt himself, who can, and I am sure will cheerfully supply every information I may have omitted; and I feel sure you will agree with me in saying, that he deserves the encouragement of the public not only for having shown them what may be done in erecting cheap and elegant greenhouses, instead of the formal and ugly right-lined buildings we usually see, but also for his just appreciation of the true policy of a tradesman in the present day, in the exertions he constantly is making to collect every thing that is worthy of cultivation for its beauty or its rarity, and in offering it to his customers at a reasonable rate. Indeed, he has already largely reaped the fruits of this practice, in the extensive business he has carried on

in many distant countries, as well as in his own neighbourhood. — *T. W. The Banks, near Barnsley, June 1837.*

*Bad Effect of growing Peaches and Grapes in the same House.* — On my coming here I found a small vinery for early forcing, a small peach-house also for early forcing; a greenhouse, two pine-pits, frames, &c.; and two houses about 50 ft. long each, 13 ft. high at the back, and 14 ft. wide; and in each were trained against the back wall peach and nectarine trees, and also on a table trellis occupying all the centre of the house (except the walk at back, and the flue in front), and all the length but the space taken up by the end flues. Up each rafter in both houses were trained vines; a practice which every experienced gardener knows is attended with a great deal of trouble and anxiety, and generally with very bad success. Bad as the practice is, I have no doubt but you have often seen it in use; and where there is but one house for the purpose, some excuse might be made for it, although it often happens that by trying for too many things in one house, we often spoil all, or get nothing in perfection; to do which, crops ought to be attended to in the best possible manner, and all the intruders made subordinate to it. But here I had two houses applied to the selfsame thing, and the crops injuring each other in many instances; the vines shading the peaches; and by giving air to accommodate the peaches at the setting and stoning season, the vines became chilled, and the bunches in a great measure ran away to tendrils. At the ripening season the peaches had neither colour nor flavour, and what few grapes did remain were not ripe before the autumnal rains set in, which caused them to damp and rot.

The rains here are quite different from what you have near London; falling at times as fine as vapour, and searching through every lap in the glass, and every crack and crevice in the sides and roof of plant structures, and at the same time causing a very great depression in the temperature, often as much as 20° in a very few hours. I have often seen grapes, by means of these fine rains penetrating the house, as wet as though they had been dipped in water.

It is true that, owing to the chilly moist state of the atmosphere, we are not troubled with many wasps or flies; and as to earwigs, which are so abundant in some places, I have not seen one during my stay here. However, I thought I would separate the peach trees and the vines, so that I should be able, in a greater degree, to give each its proper treatment. This I did by converting one house into a vinery, and the other into a peach-house, in the following manner. I took away the table trellis altogether from the centre of the houses, and put a cross trellis under every other rafter, previously taking down the vines from both houses. Then I made good the back wall of one house with the best of the peach and nectarine trees, and the remainder of these trees I planted back to back against the cross trellises, just as trained trees are planted in a nursery. By this means I have a great deal more room in one house than I had in both before, and the fruit is very much improved both in colour and flavour, as the one side gets the sun in the morning, the other in the afternoon, and there is no place shaded all the day. The back wall is exposed to the full influence of the sun all day, and it ripens the fruit considerably earlier than the cross trellises, thus prolonging the fruit season as well as if I had two common houses.

In the other house I bent down the vines which previously occupied the rafters, and made layers of them on each side of the cross trellises (by which means I had a crop the first year), and cut them down in the autumn. At the back wall I planted young vines, which made wonderful growth the first year, and bore a few bunches the next, which, like the peaches, ripened more early than those on the cross trellises: both were much improved in flavour, owing to the full influence of the sun. — *J. Nash. Arlington Court, Dorsetshire, April 26. 1838.*

*Effects of the Winter of 1837–8.* — I do not perceive that you have from our quarter here received any return of the killed and wounded in the severe

battle of last winter, when General Frost so provokingly snatched the laurel from us, and left the field bestrewed with our dead and dying.

*Wounded.*

Bignonias  
Chimonanthus  
Cypress  
Hydrangeas  
Walnuts  
Kalmias  
Magnolia tripétala, and others  
Rhododendrons, several sorts  
Rhus Cótinus  
Ribes speciòsum  
Robínia viscòsa  
Roses, China and Noisette, Bánksia,  
Macartney, and a few others  
Pæònia Mòutan  
Spártium multiflórum  
Jasminum, several sorts  
Laurels, common and Portugal  
Ulex, or Furze, above ground  
Evergreen oak.

*Killed.*

A'rbutus, young plants  
Búddlea  
Cístus ladaníferus  
Dáphne Dauphíni, and others  
Erica mediterrànea, and others  
Jasminum revolútum  
Privet, Chinese  
Lonícera flexuòsa  
Mulberry, white  
Passiflòra cærúlea  
— raceinòsa  
Laurustinus  
Còrnus capitata  
Alexandrian laurel, though last not  
least, doubtless stolen to deck the  
General's brow.

These are a few of the slaughtered and injured, and I trust their fate will teach us to be better prepared and fortified against the attack of that or any other northern power in future. — *W. Godsall. Nursery, Hereford, Jan. 17. 1839.*

## SCOTLAND.

*Improvements in Cottage Buildings and Cottage Gardens.*— This important subject will be prominently brought forward at the ensuing meeting of the Highland and Agricultural Society at Berwick. We are permitted to extract the following passage from a pamphlet which is now in the press, written by a gentleman in this neighbourhood, and entitled “The Peasantry of the Border, an Appeal in their Behalf.” “Give them good Cottages, and help them to educate their Children.”

“The movement is begun. Cottages are springing up, gardens are blooming, and schools are being constructed, which attest that many lords of the manor are anxious that the ‘cottage homes of England’ should be as much the abodes of comfort as their own mansion-houses. I have already alluded to the efforts of the Highland and Agricultural Society; and, even while I have been preparing this appeal for the press, a prospectus has been sent to me, which contains ‘The outline of general rules for a Society supplementary to the Agricultural Society of the county, to promote the improvement of cottages and cottage gardens in Northumberland.’

“In addition to this happy token for good, an announcement has been made, that many of the leading members of agricultural societies, visitors from a distance, as well as proprietors from each side of the Border, who are expected to be present at the meeting at Berwick, to be held Sept. 29. and 30., and Oct. 1., are invited to partake of the hospitalities at Etal House on the 2d October, in order that attention may be directed to the practical ameliorations which have already been effected, and to those which would further result from an extended association to improve the condition of cottages and cottagers.” (*Berwick and Kelso Warder, Sept. 18. 1841.*)

ART. IV. *Retrospective Criticism.*

*RECENT Urine of Sheep.*— It is stated in the *Suburban Horticulturist*, p. 38., that the recent urine of sheep does not kill grass, but I can assure you it does;

and had you been here in the early part of June, I could have shown you thousands of patches of dead turf, caused by their urine, in a park where no other animal is allowed to graze. The fact is, that the recent urine of sheep destroys grass the same as the recent urine of most other animals, more or less, according to the quantity which is dropped on the grass at once; but, as the sheep lets its urine down in small quantities, the damage done is not perceived, except in very dry weather, when the water is absorbed by the soil on the one hand, and evaporated into the atmosphere on the other, almost immediately, and the salt left, which destroys the grass in patches about the size of a man's hand. — *John Pearson. Kinlet, near Bewdley, Sept. 30, 1841.*

*Propagation of the Dahlia.* — In answer to the observations of C. O. on the propagation of the dahlia, I think he has misunderstood my meaning; it was not that the buds at the base of the cutting shoot into growth as branches, but that they grow upwards with the piece of the stem left below the buds, as it expands and elongates upwards in growth, till the buds are, consequently, elevated above the crown of the tuber, and are situated on the stem, and not in the tuber at all. When the cutting is taken off, the shoots are not, generally, much elongated between the joints, in general about  $\frac{1}{2}$  in. or 1 or 2 inches at the utmost; but as the stem elongates in growth by the expansion and addition of cellular matter in the summer, the distance between the joints will be expanded from 2 in. to 1 ft. In paring as near to the buds as we can, we must not injure the base of the leaves, in the axils of which the buds are situated, as it is from the bases of these leaves we expect the fibres to issue which are to form the roots; this necessitates us to leave a space of stem below the buds, of at least from  $\frac{1}{16}$ th to  $\frac{1}{8}$ th of an inch, which will elongate in the growing to a good deal more: and as the underground stem, forming the tubers, proceeds from the root, we cannot see that the buds left are to be included in the crown of the tuber, they will be formed on the stem above the tuber. We have frequently been in the habit of cutting the new and rare sorts down for propagation into single joints; thus we had often five or six single joints, or eyes, from a rooted cutting sent down to us from London, and we have always found we could depend more on the pit roots from them in the spring, than from the old roots. From one to seven buds, neither pairs nor multiples of pairs (consequently, neither the pairs of basal buds, nor companions of them), have sprung from them, some of them far down on the tops of the bend of the tuber, as well as below; while the old roots rotted in the crown from not being ripened, and were useless. Of what use is it whether vegetable points are formed at the edges of the medulla, if the tissue is not sufficiently ripened to form them into buds, and preserve them during the winter? The crown of the root is the first to fail, when early frosts and high cultivation have kept the root from ripening; and it is, therefore, fair to infer, that the crown is the last to ripen, and form the points into buds from which the next year's shoots are to spring. We pare our cuttings close to the joints, not for the sake of including the stem buds in the root, but because we expect the fibres to issue at the joint from the base of the leaves: should the cutting be cut farther down by mistake, even midway in the space between the joints, we have generally found that the roots still spring from the joint at the base of the leaves, and the piece below is left dormant. It matters, therefore, I believe, very little whether the cutting is cut close to the joint or below; the buds, in the axils of the leaves, on the stem of the cutting, will still continue stem-buds; and the tuber, whatever part of the cutting the roots proceed from, will have its own buds formed within the tuber itself, and will not be indebted to those on the stem of the cutting. For what reason will the tuber from the cutting, said to be improperly made, be prevented from forming buds in its own way as all other tubers do? and how does it differ from the new tuber formed from a piece of the old root with a bud on it? Of what use are the buds on the stem of the cutting to the new tuber?—*R. L.*

*Mr. Mackenzie's Mode of cultivating the Gooseberry and Currant* (p. 465.), I have no doubt, answers well with him, as the following mode does in the

gardens in which I am now journeyman. Mr. Lindsay, whom you saw when you called at Raby Castle a few days ago, is noted for his large crops of gooseberries and currants. He manures the soil well with leaf mould and dung before planting, and every winter he digs between the rows, and adds more leaf mould. In pruning the currants he keeps the bushes low by shortening the young shoots to 2 or 3 inches in length. Pruning does not take place till late in spring, when the leaves are half-expanded, because in this place the birds are so numerous as to pick off a great many of the buds; therefore we leave them a full supply, whereas, were we to prune in the autumn, the few buds left on the shortened shoots would be all carried off.—*Edward Hodgson. Raby Castle Gardens, Sept. 26. 1841.*

---



---

ART. V. *Queries and Answers.*

*THE best Plan for managing an old Orchard.*—In your Magazine for September, p. 465., I find Mr. Wallace of Dunimarle invites information on the best plan for renewing an old orchard. He suggests trenching, and letting the top soil remain two years below to rot the turf, and exposing that dug up to the weather, then mixing the whole together. This plan, though good, is not equal to that of adding fresh soil; but, as Mr. Wallace justly observes, that is expensive; still it must be borne in mind that, when this is done, there would be more certainty of success, and no time lost. Two years' growth of trees is of much importance.

In all cases of replanting orchards, it is advisable not to plant the same kind of trees over again. Where pears grew, we should plant apples, &c. It is almost needless for me to mention that replanting old orchards is of little use, except something fresh is added to the soil. The better way is to plant on fresh ground; but in Mr. Wallace's case this cannot well be done, for the orchard in question is walled round, and of course it is of great importance to have it replenished.—*J. Wighton. Oct. 1. 1841.*

*Preventive against the Depredations of Snails on Wall-Fruit.*—I have this year had an abundant crop of fine nectarines; but, notwithstanding all my diligence and care, I have been able to preserve very few of them to perfection, in consequence of the nightly depredations of snails, of which I have found and killed many in the morning, which had left traces of their voracity during the night. My object in addressing you is to ask if any of your correspondents can suggest a preventive of the incursions of the enemy. The other side of my wall (of course the shady side) is clothed with currant bushes, which afford a cool shelter by day to the snails, and at night I suspect they travel over the wall. I have heard that they dislike passing across a hair clothes-line; but I would prefer to profit by the experience of any who have succeeded in finding out a remedy, rather than make experiments for myself, by which I should lose another year, and perhaps sacrifice another crop. Besides stretching a hair line along the top of the wall, it has occurred to me that thickly studding the summit with bits of broken glass might offer an effectual *chevaux-de-frise*. The suggestion of a remedy will much oblige—*An Amateur Gardener. Bristol, Sept. 13. 1841.*

We would recommend scattering over the border in front of the trees a few cabbage leaves greased on the under side, and lifting the leaves every morning, and collecting the snails or slugs which may be found under them. If any of these are so small as to be troublesome to pick up, water them with lime-water, or water in which potash or soda has been dissolved. By this means snails and slugs may be completely eradicated from any garden, which is obviously much better than merely protecting particular plants or crops from them, and leaving the animals alive.—*Cond.*

---

THE  
GARDENER'S MAGAZINE,

DECEMBER, 1841.

---

ORIGINAL COMMUNICATIONS.

ART. I. *A Summary View of the Progress of Gardening, and of Rural Improvement generally, in Britain, during the Year 1841; with some Notices relative to the State of both in Foreign Countries.*  
By the CONDUCTOR.

THE weather of 1840-41 has been favourable for growth from its humidity, but very unfavourable for maturation from the want of sun. Fruits in general, and even culinary vegetables, have been deficient in flavour, and flowers in brilliancy of colour. The shoots of most kinds of trees have been imperfectly ripened; and, in short, the only circumstance in the season favourable to horticulture is the comparative absence of insects, to which the continued cold and moisture of the atmosphere have been injurious.

“ The month of November, 1840, maintained nearly an average temperature, but was unusually damp, more than  $3\frac{1}{2}$  in. of rain having fallen during the first three weeks; and, although there was none in the last week, yet dense fogs prevailed, to the almost total exclusion of the sun's rays. December, on the contrary, was a dry but very cold month; in fact, the coldest December experienced in at least the present century. The mean temperature, instead of about  $40^{\circ}$ , its usual average, was only  $32^{\circ}$ . January, 1841, was also colder than the average; and on the 7th and 8th the thermometer was  $26^{\circ}$  below freezing, or within  $6^{\circ}$  of zero. February was also cold throughout; but, with the exception of that on the 3d, there were no frosts of intense severity. March was exceedingly fine; and vegetation, almost dormant at the commencement, made a considerable advance by the end of the month; so much so, that the horsechestnut was in leaf the first week in April, and the common hawthorn in the second, indicating an earlier vegetation than has taken place since 1834: and this is attributable to the warm sunny weather in March; for April was by no means favourable, sharp frosts being of frequent occurrence during the first three weeks. These considerably

injured the blossoms of fruit trees. May was genial; but in June and July the temperature fell considerably below the average; and vegetation, so far as regards the growth of fruits, lingered much in these months. The increase of foliage was, however, favoured by the abundance of rain; as was, also, the growth of kitchen-garden productions. August was still rather wet, but maintained a medium temperature. September was warmer than usual; and, during the first three weeks, a principal portion of the grain crops was secured, but in the end of the month a large quantity of rain fell. Wet weather was the almost constant characteristic of October, there being only four wholly dry days throughout the month, with an amount of rain equal to double the average. Most soils, both in the garden and in the field, were rendered unfit for working; and it was not before the end of the first week in November, that such operations as required the stirring of the soil could be advantageously proceeded with. In this autumn there has hitherto been very little frost; for, with a few unimportant exceptions, its only occurrence was on the night of the 21st of October. It was then sufficiently severe to destroy the beauty of the dahlias, and arrest the vegetation of similarly tender exotics. Vines on walls have not ripened their fruit; perhaps in no season has it attained a less degree of maturity. They were excited early enough, and they came into leaf sooner than in many seasons in which they have ripened tolerably well. The defect has doubtless been occasioned by the falling off in the temperature during the months of June and July; for, at the end of that period, the fruit was not sufficiently advanced to be perfected by the most favourable state of the weather that ever occurs in this climate after the time above mentioned. The deficiency of heat in the two months alluded to amounted to only 3° or 4° of mean temperature; yet the effects have been such, that the circumstance may be usefully borne in mind by those who have artificial heat at command, in order that they may avoid the consequences resulting from a temperature too low, and not progressively increasing."—*N. Nov. 15.*

*History and Statistics.*—Some notices of gardens in the neighbourhood of Paris, and of a few in England, and some notes on the progress of gardening in the United States, comprise the principal part of the information belonging to this department of the subject, as far as respects this Magazine; but in the *Gardener's Gazette* and the *Gardener's Chronicle* will be found a number of notices of gardens, public and private, in different parts of the country. Such notices are not only valuable as records of the state of gardening at the time, but interesting and instructive as containing hints for imitation, or examples to be avoided, or as affording stimuli to exertion.



Every gardener ought to visit as many gardens as he can; and the next best thing to visiting gardens is, to read faithful descriptions of them by others.

The *Horticultural Societies*, both metropolitan and provincial, continue to flourish, and to increase in usefulness. New rules for the exhibitions of the London Horticultural Society have been adopted (*Gard. Chron.* for 1841, p. 595.); and a new Metropolitan Florists' Society has been organised. (*Gard. Gaz.* for 1841, p. 101.) The Provincial Societies appear to have been paying increased attention to the subject of cottage gardens, and their efforts have been attended with the desired success. The Highland Society of Scotland is also directing its attention to this important subject, and offering prizes for the best kept cottage and garden. The Reigate Horticultural Society; the Horticultural Society of Swansea and Neath; the Horticultural Society of the North Riding of Yorkshire, under the patronage of Lord Tyrconnel; that of Buckingham, under the patronage of the Duke of Buckingham; and the Glasgow, Stirling, and Falkirk Societies, have been particularly active and successful in adding to the comfort and rational enjoyment of the cottager. The transactions of the Provincial Horticultural Societies have been given so regularly and copiously in the *Gardener's Chronicle*, that we have not deemed it necessary to continue our annual abridged notices; and we therefore refer for details to that journal and to the *Gardener's Gazette*.

*Science of Vegetable Culture.* — The periodicals of the past year have been rich in discussions on this subject. At the head of these, in this Magazine, stand Mr. Lymburn's observations on Liebig's *Organic Chemistry* (p. 97.). An analysis of the same work is given in the *Gardener's Chronicle*, one in the *Quarterly Journal of Agriculture*, and one in the *English Journal of Agriculture*. Dr. Daubeny's *Three Lectures on Agriculture* (p. 270.), and Mr. Lymburn's *Philosophy of Manures* (p. 335. and 408.), belong to the same subject; and we refer to our table of contents, and to the indexes of the gardening newspapers, for other publications and papers of the same kind. The chemistry of horticulture and agriculture is fortunately at present exciting much attention; and both the Horticultural Society and the English Agricultural Society have commenced, or are about to commence, a series of experiments on the subject, the result of which can hardly fail to be of immense importance both in a scientific and practical point of view. The Duke of Devonshire has liberally contributed the sum of fifty pounds a year, and a few friends of science have also subscribed, towards the expenses of "an enquiry into the Chemistry of Horticulture, more especially with reference to the influence of soil and manures upon garden plants." This has enabled the Council to nominate a

Committee, which is to determine upon the nature of the experiments to be undertaken, and to report from time to time the result of their investigations. The duty of conducting the experiments has been intrusted to Mr. Edward Solly, jun., "already so favourably known for the skill with which he managed the chemical examination of the substances submitted to him by the Committee of Agriculture of the Asiatic Society." (*Gard. Chron.*, vol. i. p. 379.)

*Experimental Culture.*—The application of powdered charcoal to the growth of plants, and more especially to the striking of cuttings (p. 221.), and the experiment of sowing seeds in snow (p. 302.), have been attended with some interesting results. Cuttings and leaves have been rooted in charcoal, that gardeners had never been able to root in sand; and seeds have germinated in snow, which come up with difficulty when sown in soil alone. It appears to have been the German practice for many years to sow the seeds of the auricula in snow, which is not unnatural, considering the native habitation of this plant: but we should not have anticipated the success which has attended sowing in snow the seeds of Cape and New Holland plants; nor has this success been yet satisfactorily accounted for on scientific principles.

*Implements, Utensils, &c.*—A draw-hoe in use in Leicestershire (p. 311.) is an implement which we can very strongly recommend, believing it to be better adapted for thinning out seedling crops than any other tool of the kind. The Guernsey weeding-prong (p. 630.) will save weeders from stooping, and lessen the necessity of using the fingers. A substitute for hand-glasses by Mr. Forsyth (p. 204.) promises to be economical, where gentlemen cut down their own timber; and a glazed flower-pot, recommended by the same intelligent gardener (*Gard. Chron.*, vol. i. p. 499.), and which is manufactured by Mr. Legg of the Furnace Lane End, Staffordshire, and of superior materials for drawing-rooms by Messrs. Spode and Garrat, London, deserves a trial. These pots are recommended by Mr. Forsyth, as requiring less labour in cleaning from their glazed surface outside, and because, their bottoms being pierced full of holes, no crocks are wanted; as lasting longer, on account of the strength given to the material by the glazing, and as being handsomer in shape. Should these pots be attended with all the advantages that Mr. Forsyth anticipates, the saving of labour, and the improvement in point of shape and colour, will doubtless soon bring them into general use.

*Garden Architecture.*—A great deal of discussion has taken place on this subject during the past year; and it is but candid in us to state that Mr. Penn's mode of heating has been shown not to deserve the high eulogiums which we, in common with Mr. Marnock in the *Floricultural Magazine*, Mr. Wilmot the

market-gardener, and other gardeners and amateurs, passed on it at the time that it first attracted attention. The two chief objections to it are, that it is not so economical in point of consumption of fuel as the best ordinary modes, and that it is less certain in regard to atmospheric moisture. While we concede these points, we are far from agreeing in all that has been said against the system; and we should certainly employ it under particular circumstances, such as in a conservatory or greenhouse attached to a house, or in a low wide pit, to circulate the air from the back to the front. We wish, however, to consider the merits of Mr. Penn's system rather as under trial than as finally settled; and to be determined at some future time, when the present excitement respecting it is somewhat allayed, and when those who write on it shall have the truth for their object, and not that of merely its condemnation or defence. The most rational and unimpassioned discussion which we have seen on the subject is contained in some very excellent articles in the *Gardener's Chronicle*, by Alfred Ainger, Esq., in favour of radiant heat. The essence of all of these articles will be found in our General Notices (p. 634.), but the papers themselves well merit the attentive perusal of the scientific gardener.

Mr. Corbett's mode of heating, by the circulation of hot water in open gutters, appears to be generally approved of, more especially for houses or pits of limited extent, and where all the pipes can be laid on levels. The conducting of the heating pipes through troughs of water (p. 635.) seems also to be much liked. A mode of ventilation, by the introduction of fresh air heated by passing it through hot-water pipes, described by Mr. Green (p. 637.), promises well, and we shall be glad to hear more respecting it. A similar mode of introducing fresh air to the conservatory in the Chelsea Botanic Garden was tried by Mr. Watts in Evelyn's time, the pipes being passed through the furnace; but in this case, and also in that of heating by fresh air in Mr. Sylvester's mode, it has been found that the current of heated air when once established is continued after the fire becomes low, till at last cold air instead of heated air is admitted into the house. In the case of admitting heated air through hot-water pipes, as the temperature will probably be lower, the influx of air from without will not be so rapid, and, consequently, it will be more likely to stop at the proper point. Mr. Green informs us, however, that the current of air does continue after the fire gets low or goes out; and that he, therefore, considers it most advisable to have the ventilation tubes open only when the water is sufficiently heated to warm the air which passes through it; or when the external air is mild enough not to require much heating. Mr. Green considers that this mode of ventilation will be of the greatest service in forcing-houses and in stoves.

A fruit-room is one of those garden structures which have not hitherto been brought to that degree of perfection of which they are susceptible, with very little increased expense. The scientific principles on which they ought to be constructed are laid down in the *Gardener's Chronicle*, as well as the application of these principles, and we have given the essence of both (p. 635.). As connected with this subject, it may be observed, that an admirable mode for packing fruit has been published in the *Gardener's Chronicle*, and which we have quoted (p. 647.). This article is by Mr. Ross, a mathematical instrument-maker, and is one of the many instances of the advantages that may be gained by bringing other arts to bear on the art of gardening.

*Landscape-Gardening.*—In the *Gardener's Gazette* of the past year, while the Horticultural Department of that paper was under our management, we gave a translation of the more important parts of Pückler Muskau's work on this subject, and of the whole of the treatise of M. Viart, entitled *Le Jardinist*; and in this Magazine we have made considerable progress with the landscape-gardening of Sckell. The latter is by far the most eminent name, as a landscape-gardener, which Germany affords, whether as a practical man in laying out grounds, or as an author. There is little in any of the works mentioned that can be of direct application in Britain; but, by knowing the systems of other authors and other countries, the British gardener will be the better enabled to generalise on this department of his art.

In the course of a tour in Scotland and the North of England, the details of which will be found in our ensuing volume, we could not help remarking, in the grounds of country residences, the general want, not of high keeping, for that we did not expect, but of what we shall call appropriate keeping. Thus, suppose two shrubberies, one old and abounding in large shrubs and trees, and the other comparatively new and containing only young trees and shrubs, with roses and herbaceous flowers: the mode of keeping both these shrubberies is generally the same; that is, the ground is dug in the winter season, and kept hoed and raked during summer. Now, this may be very suitable for the young shrubbery, in which there is still abundance of room and of light and air to admit of roses and herbaceous plants flowering freely; but in old shrubberies, where these plants are so far choked as to be in a sickly unhealthy state, digging the few portions of surface that remain uncovered with branches can be of no use to either the large shrubs or the stifled low plants. It ought, therefore, to be discontinued; all the low and unthriving plants removed; and the surface of the bays and recesses, which will occur along the front, turfed over, or sown down with proper grass seeds, and afterwards kept mown. It ought, we think, to be received as a general rule in the

management of shrubberies, that no detached plant that is not in vigorous growth or in a healthy state, and in a situation and soil where it may continue healthy, ought to be allowed to exist. A shrubbery where this is attended to is managed in what we call the gardenesque manner, the essence of which is to have no plants, either large or small, that are not handsome as individuals; but there is also the picturesque manner of managing shrubberies and plantations, the essence of which consists in having no plant that does not group or combine with some other plant or plants. Hence, in such a shrubbery, there may be some plants that, when taken individually, would be considered unsightly from having grown all to one side, or being drawn up with few side branches, or having only side branches and no leading shoot; but, when two or more of such plants are grouped together, they form a combination, or whole, which is as interesting to the lover of the picturesque, as the handsome single object is to the lover of the gardenesque. When, therefore, imperfectly shaped plants are permitted to exist in a shrubbery, they should always be in combination with other plants, and never allowed to stand alone.

When a shrubbery is once planted, many persons think that all that is necessary is to give it the routine culture of digging, hoeing, and raking, with perhaps occasional pruning; but, to keep a shrubbery in high order, it requires to be gone over every year in autumn, in order to thin out superfluous plants, and prune where it is necessary to keep certain plants within bounds; and it ought also to be frequently looked over during the summer months, to cut off all decayed flowers from the more rare or valuable shrubs, such as roses, rhododendrons, azaleas, tree pæonies, &c., which, if left on the plant to produce seed, would weaken it for the next blossoming season, by appropriating to the fruit the nutriment which would otherwise be devoted to the formation of blossom buds. In some cases, however, it is desirable not to take off the decaying blossoms, on account of the beauty of the fruit, as in all the thorns, crabs, berberries, *Rhús*, *Arbutus*, spindle tree, and even the mezereon and honeysuckle.

Whenever the plants in a recently planted shrubbery become so large as to injure the growth of the roses and flowers that are generally planted on the outer margin next the walk, the roses, &c., ought to be removed; and when these are all taken away, digging, being no longer necessary, ought to be discontinued. The surface of the shrubbery will then be chiefly covered with the branches of the shrubs; and such bays, recesses, and retiring glades as remain uncovered, which constitute one of the beauties of a shrubbery, should, as we have already observed, be turfed over or sown down. In some cases, the surface may be covered with ivy or with periwinkle, and in

shady moist situations it may be left naked, in order to encourage the formation of a carpet of moss. In short, for a grown up shrubbery, any mode is better than a surface kept in a continual state of movement by digging, hoeing, and raking; a continuation of the means long after the end has been attained, and which, to those who think at all on the subject, can only give the unsatisfactory idea of labour misapplied.

It may be said, that in some cases this winter digging is so far useful that it covers in the fallen leaves, and that these serve as an annual manuring to the plants. Granted: but, where this annual manuring is necessary, we would not admit of the digging, but would rot the leaves in heaps in the back part of the shrubbery, and strew the mould thus produced over the surface. We contend, however, that most shrubberies, after they have attained a certain age, require to be starved rather than nourished, in order to keep the shrubs within bounds; and, at all events, that the leaves which drop on the ground, and lie concealed by the branches, generally afford nourishment enough to the plants. In shrubberies where there is a mixture of trees, and the trees and shrubs are continued along both sides of the walk, it frequently happens, after a certain number of years' growth, that the walk is completely covered, at the height of 10 or 12 ft. from the ground, by the spreading branches of the trees. Such a shrubbery can only be managed in the picturesque manner, and we should, therefore, have no hesitation in covering the ground with ivy or periwinkle, and allowing the leaves from the trees and shrubs to rot where they fell, partially concealed, as they would be, by the creeping or trailing evergreens.

One of the worst points in the management of close shrubberies or plantations of this kind is, the treatment which the verge or edging generally receives. If it was originally an edging of box, it soon, from the dense shade, and from the neglect of filling up the gaps occasioned by death or accident, shows a ragged starved line of that plant; or if it has been a verge of turf, perhaps 2 feet wide, it becomes reduced, by continued paring on both sides, to a strip of soil of 6 in. in width, with scarcely any appearance of grass. The native oxalis has been proposed as a substitute by Mr. Mackenzie of West Plean (p. 645.), and we have no doubt that plant would answer in many cases; but, if the surface of the plantation were covered with ivy or periwinkle, an evergreen clothing would be formed, which it would only be necessary to keep within bounds by the verge-shears.

The keeping of a place may be defective from a want of consistency, as well as from inappropriateness. By consistent, or, in other words, by uniform keeping, we mean that keeping in which every part of a place has a degree of care and labour

bestowed upon it according to its rank and importance. The centre of all art and refinement, in the grounds of a country seat, ought, in general, to be on the drawingroom front of the house: next in order is the pleasure-ground; then the flower-garden, which forms a part of the pleasure-ground; then the shrubberies or plantations near the house, in which there are kept walks, which also belong to the pleasure-ground; next the approach-road; and, lastly, the kitchen-garden. It not unfrequently happens that the lawn in front of the house is comparatively neglected, while the highest-kept part of the place is the kitchen-garden; and we also often find both the lawn and the kitchen-garden highly kept, while no more attention is paid to the sides of the approach-road than if it were a common road through a grass field. In every highly kept place, where the approach-road leads through open scenery with pasture on each side, the coarse tufts of grass, withered flower-stalks, and all coarse plants, ought to be mown off for a few yards on each side of the road, two or three times during the summer; and the edgings should, of course, be kept low and clipped with the verge-shears, instead of being pared with the spade. As a kept walk is a highly artificial part of landscape scenery, it may be laid down as a rule, that whatever description of scene it passes through ought to partake, more or less, of the character of art. Even when the walk is carried across a grass field, or a part of the open park, the surface ought to be smoothed, and the grass kept free from tufts or flower-stems, for a few yards on each side; and something of the same kind ought to take place when it passes through woods or plantations, unless the surface is covered with ivy or other evergreens. In short, in even the wildest scenery, when the walk is carefully formed by art, of uniform width, and gravelled, the same art ought to extend its influence to a certain distance on both sides, whether among grass or plants, and ought to be particularly conspicuous on its edges.

Though we have placed the kitchen-garden last in the order of importance with respect to high keeping, it does not follow that it is not to be kept in a suitable manner. Order and neatness ought to pervade every part of it; and, indeed, it can hardly be properly managed, with a view to utility, without this being the case.

*Arboriculture.*—Some valuable papers on pruning have appeared in the course of the year, among which those by Mr. Cree of Biggar deserve particular attention.

“ We do hope that, though Mr. Cree has been comparatively neglected by his countrymen, some spirited English proprietors of plantations will take his system into consideration, and either send their foresters to Mr. Cree for instruction, or send for Mr. Cree to instruct their foresters, and to prune some

trees as examples. Mr. Cree's principal employment is as a professional pruner, and he goes out at the very low terms of half-a-guinea a day, and his travelling expenses. (*Gard. Gaz.* for 1841, p. 500.)

An economical mode of procuring single trees has been pointed out in this Magazine (p. 509.), and enlarged on in the *Gardener's Gazette* for Oct. 23.; and, in a subsequent number of the same Journal (Oct. 30.), we have shown the advantage, when large masses are to be planted, of preparing the soil by the use of a four-horse plough, followed by the subsoil plough. The advantage of heading down stunted single trees of considerable size, and of cutting over by the ground young trees that stole after they have been three or four years planted; of using the pruning-shears much more extensively than has hitherto been done by foresters; and of cleaning hedges early in the season, before the side shoots have been protruded from the lower part of the hedge, have been pointed out and enlarged on in leading articles in the *Gardener's Gazette*, not as new practices, but as practices which deserve to be more generally resorted to.

We were happy to see, during our tour, considerable progress made in different places towards planting collections of trees and shrubs, or, as they are technically called, arboretums. We may refer to Corehouse near Lanark, Posso near Peebles, Dalkeith Park, Hopeton House, and some other places about Edinburgh, Ravensworth in Durham, and Moreby Hall and Bramham Hall in Yorkshire. Pinetums are also being commenced in various places. In furtherance of one object to be obtained by collections, that of creating an interest in trees and shrubs by attaching the names to them, which may serve as indexes to their history in books, we are happy in being able to state that permanent labels of iron and lead, or of lead alone, are prepared by Messrs. Lucombe and Co. of Exeter, and Messrs. Whitley and Osborn of Fulham, and sent out along with the plants when desired, at very moderate prices. The lead labels of the smallest size are 2 in. by 4 in., with the name and the native country stamped on them with steel types, in such a manner that they cannot be obliterated for many years, and they cost only 12s. per hundred. These labels have holes at the angles by which they may be nailed to larch or other stakes, 3 ft. in length, with the bark on; or they may be of larger size, and attached to such shanks as we have figured in p. 230.: lead labels of the size proper for these shanks will cost 2d. each. We would strongly recommend gardeners and their employers to have named by these, or by some other equally durable means, all the trees and shrubs which are not universally known among gardeners; and also all the fruit trees, vines, and even one plant of each of the more rare kind of ananas. In the case of wall trees and espaliers, and also of vines, the label can be nailed



to the wall, espalier post, or rail, and to the rafter or trellis. The mere circumstance of having the plants and fruit trees about a place correctly named raises its character among gardeners, and insures a better class both of master gardeners and their assistants. It is also favourable to correctness and good habits generally. A gardener, where there is a good collection of named articles, not only commands apprentices of a superior school education, but cuttings of many rare plants, which he would not receive if he had not something adequate to give in return. Besides, it generally happens that some members of the family of the proprietor have a taste for botanical pursuits, and to them the circumstance of the plants in the garden and pleasure-ground being correctly named must be a very considerable assistance in their studies.

A few new trees and shrubs have been raised in the Horticultural Society's Garden, of which a catalogue is given by Mr. Gordon (p. 608.); and, what it will be of immediate practical utility to state, Messrs. Whitley and Osborn have added upwards of 30 species and varieties to their printed catalogue of last year. We have obtained a list of between twenty and thirty new or rare species recently introduced into the Tooting Nursery by Messrs. Rollison, which will be given in our next Number; and, with Mr. Gordon (p. 35.), we would strongly recommend nurserymen and the curators of botanic gardens, in every part of the country, to send us Annual Reports of the new or rare articles which they have raised from seed, or otherwise added to their collections. We conceive that the public is under great obligation to every nurseryman who maintains a good collection and increases it; for, assuredly, rare trees and shrubs, which are only sold now and then, do not pay him nearly so well as the cultivation in large quantities of the common sorts.

Various articles on the preservation of timber will be found in the present volume, though we can scarcely as yet point to any practical results which a gardener can imitate. Nothing can be more beautiful in theory than the experiments of Dr. Boucherie (p. 642.); and some of them, at least, might be repeated by a gardener or forester, with a very little assistance from a chemist. Sir W. Burnett's mode every gardener might put to the test, by trying it on bast mats.

*Floriculture.*—Our Floricultural Notices exhibit, as usual, the names of a great many new plants which have been figured in the course of the year, and the whole are assembled in a select list which forms part of the Contents. There is a valuable list of plants adapted for a conservatory wall, with several instructive papers on the management of the *Cacti*, one of considerable commercial importance on the cultivation of *Irídeæ* in the Island of Jersey, and some interesting articles on the *Dahlia*;

and, under General Notices, there are a great variety of articles on this department, which can hardly fail to instruct, and which, at all events, will be read with pleasure by every lover of gardening, on account of the associations which they will call up in his mind.

*Horticulture.*—There are so many interesting papers on this subject in the present volume, that we cannot spare room to particularise them. Perhaps the most valuable articles are those on the cultivation of the grape, the shriveling of the fruit in various places having called forth the energies of several cultivators. Root-pruning, to which Mr. Rivers (p. 625.) has lately directed public attention, is a practice capable of being much more generally applied than has hitherto been done; not that gardeners are ignorant of it, for it was long since recommended from the *Caledonian Hort. Soc. Mem.* in the first edition of our *Encyclopædia of Gardening*, but that pruned roots, being unseen, do not make that impression on a stranger visiting a garden where it has been practised which top-pruning does. The subject of insects on fruit trees has, as usual, occupied a good deal of the attention of cultivators; and that of the diseases to which wheat and other grains are liable has given rise to some valuable papers, by Professor Henslow, in the *English Agricultural Journal*.

A few new varieties of fruits and culinary vegetables have been brought into notice, and are given in a Report by Mr. Thompson, accompanied by some judicious remarks. The fruit of *Berberis dulcis*, commonly known in the nurseries as *Berberis rotundifolia*, has been ripened in Mr. Cunningham's nursery, Edinburgh, and found excellent; Mr. Cunningham says, "as large and as good as a black Hamburgh grape;" and, if so, we have no doubt that it will soon come into cultivation as a fruit shrub. Mr. Herbert has found the berries of *Fuchsia fulgens*, not only eatable, but excellent (p. 648.); and the same remark will apply to the roots of *Oxalis Déppeii* (p. 648.). Some Chinese vegetables have recently been tried by the French, but sufficient experience has not yet been obtained to enable us to determine their merits. In the Report of the progress of the Horticultural Society from 1830 to 1840, published in their *Transactions*, second series, vol. ii. p. 428., will be found a List of Fruits and Culinary Vegetables which have been examined during that period, and found deserving of general cultivation. This List will be given in our ensuing volume.

*Agriculture.*—The progress which this art is now making is rapid, both in England and Scotland, chiefly by the adoption of the frequent or furrow drain system and subsoil plough. These are both the invention of Mr. Smith of Deanston, to whom the landed proprietors of Britain, and more especially of Scotland, are under a debt which they can scarcely ever repay. In the

course of our tour we had an opportunity of seeing the frequent-drain system in every stage of its progress, and found that in many parts of Scotland rents had been trebled and quadrupled by it. In Northumberland and Durham we found Mr. Smith's system frequently adopted, and between York and London it may occasionally be seen in progress. A farmer in the neighbourhood of Dalkeith has recently made a considerable improvement in the manufacture of draining tiles, which will extend the practice by rendering it less expensive. The use of these tiles pierced with holes is about as great an improvement on the mode of draining by small stones formerly practised, as Mr. Forsyth's mode of piercing the bottom of flower-pots promises to be on the use of crocks or other rough drainage. The tiles, however, are found to require small stones or gravel laid over them, and so, probably, in many cases, will the pierced bottoms of Mr. Forsyth's flower-pots, if it were for nothing more than the purpose of admitting air to the roots. A new species of clover, *Trifolium giganteum*, has been introduced from Affghanistan, and a new variety of lucern from Candahar. The latter is chiefly valuable as coming in earlier than the common species; but the clover appears to be a valuable acquisition, having in Ireland yielded at the rate of 37 tons per acre cut green. (*Gard. Chron.*, vol. i. p. 631.) At the last meeting of the Highland and Agricultural Society of Scotland, held at Berwick, promises were given of an increased attention by that Society to the subject of cottages and general education (p. 572.), with which we were much gratified. The meetings of the English Agricultural Society, and their very excellent Journal, are silently effecting great and important changes in field culture and live stock. The principal subjects which occupy the attention of gentlemen farmers in both countries are, the important ones of draining, subsoil-ploughing, and saline and concentrated manures; although it may be mentioned as somewhat remarkable, that the first two practices have been carried too far in light sandy soils in some parts of England.

*Rural Architecture.* — The public taste in architecture is gradually becoming more refined, more especially in the country, by the many churches and villas that are being erected or repaired, and by the very handsome station-houses which frequently meet the eye while gliding along the railroads, both in England and Scotland. Landed proprietors, however, do not seem fully alive to the high degree of ornament which they might confer on their estates, by giving their cottages and farm buildings a more artistical character.\* There are now

\* It will scarcely be credited, for how small a sum a plain homely design for a labourer's cottage, that does not exhibit exteriorly even a germ of architectural taste, may be rendered highly architectural. Suppose the erection of a cottage of the most homely description to cost, for labour and

so many cheap books containing designs for cottages, that this neglect seems almost inexcusable. Nearly all country gentlemen retain a carpenter for repairs, and for work to be done under their own inspection, and it would be for their interest to put into the hands of such persons books of designs which might tend to cultivate their taste. It is much to be wished, also, that ladies would take a greater interest in the picturesque beauty and comfort of the cottages erected by their friends; and, in short, that they would bestow a portion of their time on the study of architecture.

There is one department of rustic architecture to which we would earnestly invite the attention of country gentlemen, the ladies of their families, and also their gardeners and stewards, and that is, the erection of rustic structures formed of the thinnings of plantations with the bark on. We are far from recommending the imitation of those grotesque seats and summer-houses, formed of peeled oak branches, so commonly exhibited for sale in the neighbourhood of London, because the different parts of these structures are put together without any evidence of cultivated design. The materials that we recommend are poles or young trees, of from 6 in. to 9 in. in diameter at the thickest end, of Scotch pines, larches, spruce firs, oaks, alders, and a few others which grow straight, and in every case we prefer them with the bark kept on. These can be formed into a great variety of structures, useful and ornamental, at very little expense beyond that of the labour of the carpenter. By these poles the most common-place exteriors of cottages may be rendered picturesque; every variety of covered seat in pleasure-grounds;

materials, 60*l.*; then, to render it artistical, it may be submitted to an architect, say in London or Edinburgh, who, for indicating certain changes and additions, may charge two guineas; and those additions, when executed, may cost 4*l.* or 5*l.* Thus, it may be calculated, that to render a homely country cottage of any kind artistical, and an ornament to the country, will, all expenses included, not exceed 10 or 12 per cent.

On reading to Mr. Lamb what we have written, he says that the architect, in the case of improving cottages of the lowest description, ought not to charge more than a guinea for altering a design; and that the improvements, when carried into execution, need very seldom exceed 5 per cent on what would otherwise be the cost. It is not so much, Mr. Lamb observes, decoration which is wanted, as an artistical distribution of materials. Those who have looked into our *Encyclopædia of Cottage Architecture*, or the *Architectural Magazine*, will recollect Mr. Lamb's beautiful designs for cottages and villas in the former work, and his interesting historical papers on Gothic architecture in the Magazine; and when we mention that he has been one of our travelling companions in Scotland and the North of England for the last two months, and has been as far north as Taymouth, as far west as Stranraer, and as far south as Newcastle, it will be allowed, we think, that he is competent to give an opinion on the improvement of both Scotch and English labourers' cottages. (*Gard. Gaz.* for 1841, p. 596.)

of sheds for the shelter of cattle, pigeon-houses, &c., in parks; of fruit-rooms, tool-houses, working-sheds, mushroom-houses, houses like that of Mr. Wells of Redleaf, for preserving leafless deciduous shrubs, such as fuchsias, brugmansias, &c., and even orange trees, through the winter, in gardens; of poultry-houses, dairies, &c., in farms; and of woodmen's lodges, places for shelter, &c., along drives, &c., in woods. Besides these objects, there are gates, fences, bridges, arcades, and picturesque combinations of poles for creepers, espaliers for fruit trees, decorations to wells or springs, and various other applications. We do not recommend this description of material for cottages or permanent buildings, where one of a more permanent nature can be employed; but there are many cases in which the carpenter of the place has little to do, and others where more expensive materials are not easily procured, and in all such cases rustic-work of the kind we mention affords a valuable resource. We recommend, as furnishing models, Ricauti's *Rustic Architecture*, noticed in p. 34., and another work by the same author, about to be published, entitled *Sketches for Rustic-Work*. The reader will also find a variety of designs adapted for this kind of work in our *Encyclopædia of Cottage Architecture*, and in the *Suburban Gardener*.

*Public and Royal Gardens.* — The London parks, and the recreation of the working classes in them, have of late years been more cared for by the Woods and Forests than formerly. When the Regent's Park was first laid out, about 1815, there were no roads but those adapted for carriages, and throughout the whole length of these roads there was not a single seat on which the wearied pedestrian, or a mother and her children, could sit down. Gradually, however, in consequence of the subject being taken up by the public press, this park has been in a great part opened to the public, and gravel walks, seats, and other accommodations, formed for general use. A new place of public recreation has been projected in the east of London, to be called Victoria Park, and an act passed for purchasing the ground, about 290 acres; a plan for laying out which is published in the *Report of the Woods and Forests* for 1841, and in the *Westminster Review* for November. A public park is projected in the south of London, in the parish of Lambeth, to be called Lancaster Park; and one also on the south side, but intermediate between the Lambeth park and that of Greenwich; so that in a few years we may reasonably expect to see a sufficient number of breathing-places, in and about the metropolis, for the health of the inhabitants. The Green Park, St. James's Park, Hyde Park, and Kensington Gardens, have all been more or less improved, with a view to public accommodation. For the latter we have suggested the planting and naming of a few ornamental

trees and shrubs; a fountain for the central basin, to be worked by steam; and islands near the two extreme ends of the Serpentine River, in order to conceal the terminations of that piece of water.

Some changes have taken place in the grounds about Windsor Castle; but when we saw them, in May last, they did not appear to us to merit the name of improvements. We have seen a plan for a kitchen-garden of 20 acres to be formed at Frogmore; but nothing is said of such a plan in the *Report* for 1841. We recommend the kitchen-garden at Versailles as a model.

We have elsewhere (p. 652.) stated the intention of the Woods and Forests to form public walks on the crown lands at Stirling; and, in the *Report* referred to, it is noticed that between 14 and 15 acres of land at St. Andrews, the crown leases of which had expired, are given up to the town, on consideration of their preserving certain structures already existing, including a gateway and towers, as objects of antiquarian and historical interest. This ground will, doubtless, be turned into a public garden. There are other towns, both in England and Scotland, as well as in Ireland, similarly circumstanced to St. Andrews; and we have little doubt the commissioners will be equally liberal to them when an opportunity offers. What we should wish to see, above all other things connected with public parks and gardens, are, the arrangement and planting of Arthur's Seat and Salisbury Craigs as a public garden and monumental cemetery for Edinburgh, or rather for Scotland. We would have no common graves or gravestones in it to vulgarise the conspicuous features, but only walks, and handsome monuments; the ground being planted with every tree and shrub that would grow there. Burying places for those who could not afford ornamental monuments would be provided in proper situations, and surrounded by masses of plantation.

*Cemeteries* are now established in the suburbs of London in every direction, and they are either formed or in contemplation near most of our large towns. The defects and excellences of those of Manchester, Liverpool, and Glasgow will be pointed out in the course of our tour, in our ensuing volume. We are happy to see some attention bestowed on churchyards in different parts of the country. The improvements in these consist in keeping the surface of the ground even, in consequence of which it can be mown and kept as neat as a lawn; in forming regular gravelled or paved walks through and around the area; in forming a paved gutter round old churches which have dripping eaves; and in introducing here and there a few evergreen shrubs or trees, such as the Irish yew, the cypress, the cembra pine, and, in some cases, the cedar of Lebanon. As an example of a churchyard reformed after this manner in the very best taste, we refer to

Oving near Chichester, for which the public are indebted to the proprietor of the living, Miss Woods of Shopwyke. A good deal has also been done in the same manner with some of the churchyards in Edinburgh and Leith; and a great improvement, introduced into these and some other burying grounds in Scotland, consists in the use of a box for containing the soil thrown out of the grave in digging it. This keeps the grass and the ground round the grave quite clear; and it also saves much labour, because, by taking off one of the movable sides of the box and tilting it up, the soil is instantly returned to the excavation. We shall describe this box and its uses more in detail in our next volume. It is worthy of notice, that the improvement of the churchyards of Edinburgh and Leith arose from the circumstance of gardeners having been employed in them as superintendants.

*Garden Literature.* — Perhaps the most valuable books for gardeners, which have been published in the course of the year, are, the *Selection from the Physiological and Horticultural Papers of the late Mr. Knight* (p. 327.), and a cheap and excellent work *On Vegetable Physiology*, forming part of a popular cyclopædia of natural science (p. 327. and 593.). The first volume of the *Flora of North America*, by Drs. Torrey and Gray, has been completed, and forms one of the most interesting botanical publications, in a practical point of view, that could fall into the hands of a native of Britain, who is desirous of enriching his country with the plants of other countries of analogous climates. In this first volume of the *North American Flora*, there are some hundreds of species of herbaceous and ligneous plants that have never yet been introduced to Britain in a living state; and, as the work is expected to extend to several volumes, it will show that the species which remain to be introduced from North America, and which will be perfectly hardy in our gardens, amount to several thousands. When we reflect on this, and also on the number of species which are every year being introduced from the mountainous districts of India, and which are also hardy in our climate, the mind is filled with wonder and delight at the botanical riches which at no distant time will be exhibited in the artificial scenery of this country. *The Gardener's Chronicle* was commenced in January last, and is, without doubt, a journal which will have a most powerful influence on the progress of gardening. As it must be in the hands of all our readers, it is unnecessary for us to say more respecting it; further than this, that it is our intention to note in this Magazine every thing in the *Chronicle* that we think necessary to constitute our miscellany what it professes to be, "a register of all gardening improvements." With the *Gardener's*

*Gazette*, of which we undertook the editorship about a year ago, we ceased, with the number for November 6th, to have any farther connexion, for reasons with which it is unnecessary to trouble our readers. The botanical periodicals mentioned in our Report for last year continue to prosper, and there has been added to them the *Phytologist*, a cheap botanical monthly journal. Downing's *Theory and Practice of Landscape-Gardening* (p. 421. and 472.) is a masterly work of its kind, more especially considering that it was produced in America, where landscape-gardening is necessarily in its infancy. Brande's *Dictionary of Science, Literature, and Art* (p. 177. and 599.) is a work which, though not on gardening, yet every gardener ought to possess who cannot afford the *Penny Cyclopædia*. Mrs. Loudon's *Practical Instructions in Gardening for Ladies* has come to a second edition in the course of the year; and a second edition also of her *Companion to the Ladies' Flower-Garden* is in preparation. The volume on *Ornamental Bulbs* is completed, and that on *Ornamental Perennials* will be commenced on January 1st. The first number of an *Abridgement of our Arboretum Britannicum* will appear on the 1st of December; and also the sixth number of our *Suburban Horticulturist*, which was discontinued during our absence in Scotland. Our *Supplement to the Encyclopædia of Plants* was published in June last. The most interesting work published in France in the course of the year is, we think, Auguste de St. Hilaire's *Leçons de Botanique*; and in Germany, the completion of Endlicher's *Genera Plantarum*, according to the natural system.

*Gardening and Rural Improvement in Foreign Countries.*— We have little on this subject to add to what we stated in our summary for the past year (p. 630.). The state of gardening in the neighbourhood of Paris may be gathered from our gardening visit (p. 101. 287. and 383.). In Germany, the Doberan meeting of German Agriculturists and Silviculturists was held from the 1st to the 8th of September, when a number of papers were read, and articles exhibited. "For the silvicultural section, upwards of 100 different sorts of *Pinus* and *Abies* had been sent in living specimens from the Flöttbeck Nurseries, accompanied with a descriptive account by Mr. John Booth, of which 1000 copies were distributed, and for which the president of the silvicultural section returned a vote of thanks." (*Gard. Chron.*, vol. i. p. 614.) Some new plants introduced into the North of Italy in the course of the year 1840 are enumerated by M. Manetti (p. 182. and 565.); and some notices of the gardens in the United States and in South America, by Edward Otto, will be found in p. 379. Of the Agricultural and Horticultural Society of India, an interesting account is given in the *Gardener's Chronicle*, vol. i.



p. 631.; by which it appears that the Saharumpore Botanic Garden is proving a most useful institution, both for India and Europe, by transmitting and receiving collections of seeds and plants. It is gratifying to find that every year is adding to the number of hardy articles which we receive from the Himalayan Mountains.

*Obituary.* — *Daniel Ellis, Esq.*, an eminent vegetable physiologist, and *Francis Bauer, Esq.*, distinguished as a botanical draughtsman, have died in the course of the year in this country; and we lament to be obliged to add to the list the justly celebrated *DeCandolle* on the Continent. As an eminent patron of gardening and architecture, who possessed the most refined taste in both arts, we have to deplore the loss of *Lord Monson*, who, at Gatton Park, Surrey, had projected a series of improvements which would have rendered that place one of the most remarkable in England. Lord Monson was not less distinguished for his refined taste and good sense, than for his universal benevolence and amiability.

ART. II. *Notice of Bohemia Park, the Property and Residence of Wastel Brisco, Esq.* By H. C. O.

THE notices of gardens and country seats in your Magazine I have always considered extremely interesting; particularly when points of good culture, or when any remarkable facts, are included in the observations. Such being my opinion of them, I shall, as occasion offers, forward you a notice of any place I may see, which I think may be interesting to your readers, leaving it to your judgement whether or not you think it worthy of insertion. My powers of description are not equal to those of many of your contributors, but I hope an occasional practical observation will make up for other deficiencies. With regard to the architectural style of the house, in any of my notices, I shall say but little; indeed, I think there would be a difficulty in distinguishing many of them as belonging to any particular style.

*Bohemia*, the residence and property of Wastel Brisco, Esq., is situated about one mile north-west of the town of Hastings, and commands singularly beautiful and extensive land and sea views, extending from Beachy Head to Dungeness Point. The house, a modern-built one, stands on a declivity, the ground rising gradually; it was the residence of the Princess Sophia of Gloucester in the year 1830. The present possessor has enclosed the estate with a stone wall, which is a great improvement

as far as regards that portion adjoining the high road; but the principal improvements are in the garden.

On the east side of the house, and adjoining to it, is a large green-house, which contains some fine specimens of geraniums, particularly Smith's new scarlet; also May's new fuchsias, many species of *Cácti*, a fine plant of *Abútilon striátum*, and a quantity of young plants of *Araucària imbricàta*, raised there from seed, the whole of which were very healthy. In front of the house is a broad terrace walk, with which I was particularly struck; it being apparently very hard and level, an occurrence very unusual in this neighbourhood, from the want of good gravel. The gardener, Mr. Fielder, informed me it was composed of pounded chalk, and fine shingle from the sea-side, made into a mortar, laid down in its wet state, 6 in. thick, and rolled as soon as it got a little set; it appeared almost like a solid pavement. Two feet below this walk, and divided from it by a green bank, is a piece of level turf about 50 ft. wide, from which you descend by a flight of steps to the flower-garden. This is divided from the lawn by a neat stone wall, having a southern aspect, the top being on a level with the lawn: there were some fine plants of *Erythrìna Crìsta gállì*, *Sálvia patens*, *spléndens*, *fúlgens*, *involucràta*, &c., planted against it, beautifully in flower. The flower-garden is laid out in beds of various shapes, the whole forming a square. The walks are 4 ft. wide, made with the same sort of materials as the above terrace. The beds are judiciously planted with *calceolarias*, *heliotropiums*, *geraniums*, *pansies*, *berberries*, &c., also several fine specimens of *Tropæolum tricolòrum*, and about 150 varieties of China roses, many of them first-rate sorts. Mr. Fielder informed me that he has a splendid collection of bulbs, to take the place of the tender plants as soon as they are destroyed by frost.

To the south of this, and leading to the kitchen-garden, which is entirely out of view, are the pleasure-ground and shrubbery, containing some beds of roses, rhododendrons, azaleas, and other shrubs, as well as many choice coniferous plants; among others, *Araucària imbricàta*; the whole of which are growing luxuriantly, and appear to stand the sea air well. Below this shrubbery is the kitchen-garden, containing about one acre, surrounded by a wall 12 ft. high, into which are built iron loops; willow rods are introduced through them to train the trees to, and answer the purpose very well: thus, nailing is entirely done away with.

The young trees, which were planted at the time of the formation of the garden, two years ago, are in a very promising state. The walks have brick edges, which in many situations are preferable to box, or any of its substitutes. On the north side of

the garden, and at a distance from the outside of the wall, is a high bank, caused by excavating the earth to make the garden level: against the bank there is a wall built, to prevent the earth falling into the north slip. On the top of this bank Mr. Fielder has planted pear trees, and trained them downwards: at present they are looking well. Close to the back of the stables is a range of cucumber and melon pits; the latter contained an excellent crop of the Beachwood green-flesh. Preparations are making for a range of pine-pits; and I have no doubt, in the hands of the present spirited proprietor and his gardener, Mr. Fielder, Bohemia will become a place of considerable note with the surrounding country. — *August*, 1841.

---

ART. III. *The Principles of Gardening physiologically considered.* By G. REGEL, Gardener in the Royal Botanic Garden, Berlin. (Translated from the *Garten Zeitung*, May 9th, 1840.) (Continued from p. 535.)

I. ON THE PROPAGATION OF PLANTS.

B. Propagation by Buds.

1. BUDS AND THEIR METAMORPHOSES — *continued.*

THE bulb is a metamorphosed bud in a higher state of advancement, the different parts of which it is composed being all increased in size, and more fully developed. That part which represents the axillary portion of the bud is very much enlarged in the bulb, in the lower part of which it forms the large circular disk called the root-plate. On this are fixed the scales which represent the leafy coverings of the bud, but in a much higher state of organisation; and their form is determined by that of the leaves of the species to which they belong. If the leaves can be traced distinctly into the bulb, it is said to be tunicated, as in the onion; and, if they cannot, the bulb is called scaly, as in the lily.

Bulbs are generally propagated by offsets, which partake of the nature of seed, in producing distinct individuals; and, like seeds, they resist external influences, and retain their vital powers for a great length of time: thus, the offsets of some kinds of *Allium* often germinate after having been kept in the herbarium upwards of a year. On the root-plate is formed the new bulb, which is to supply the place of the old one the following season, just as new buds form every autumn to supply the place of those that have been developed the preceding spring: but, in the bud,

the latent buds, or germs, which exist in the axils of the leaves are rarely called into action; while in bulbs, the corresponding germs are very frequently developed in the form of little bulbs, which appear on the margin of the root-plate. The same germs, or latent buds, when they exist in the axils of the flower buds, appear to become ovula, and after fructification to change into seeds. These metamorphosed bulbs appear either singly or several together; and, in the latter case, they are sometimes, as in *Allium sphærocéphalum*, seated on a long bundle of vessels, which looks like a filiform pillar, and in its development shows some analogy to the umbilicus of seeds. I am of opinion, therefore, that these ovula and the offsets are both produced by a change in the rudiments of the bud; and that the offset and the seed are at first similar structures, but that, from the various changes they undergo, they are transformed into differently organised parts, which, however, in their functions bear a great resemblance to each other. As a proof of this may be mentioned the transformation of the ovula, after imperfect impregnation, into bulb-buds, as in *Juncus supinus* and *Pòa bulbòsa*; or into bulb-tubers or corms, as in *Pancrätium*, *Crinum*, *Amarýllis*, &c. The latter, however, never happens when the plants are artificially impregnated; and when we think we perceive an embryo in these growths, it consists only of the already formed young shoot of the tuber, which is surrounded by the thick testa. The succeeding stages of growth prove this; as the plant is developed, not like a monocotyledonous seed, but like a bulb-tuber or corm. In the seeds of the *Orchidæcæ*, also, a very remarkable phenomenon is observable. They have a testa of very delicate construction, much larger than the embryo within, which, by the help of a glass, appears like a dark dot in the middle of the single cellular integument. Perfect fructification seems to have taken place in all the extraordinary number of small seeds in a seed-vessel, though their coming to maturity seems to be prevented by their being so numerous. In the few cases in which germination has been observed, the embryo gradually swells and forms itself into a tuber before it makes roots; and, as it appears that all seeds of the *Orchidæcæ* undergo this metamorphosis, it may account for their being so difficult to germinate, as otherwise, from the nature of their testa, it is probable they would very soon come up. Finally, among plants of a lower organisation, there are beautiful analogies between seed and seed-grains. Thus, *Mnium andrógynum* *L.* scarcely ever perfects its fruit; but, instead of it, there appear on the point of the fruit-stalk granules or seed-buds. The whorl of leaves which forms the capsule decays, and on the fruit axis, instead of real seeds, a number of small stalked seed-grains are found formed, like little beads. This formation will be understood from the above de-

scription: the seed-grains entirely fill the place of seeds; all possess vitality, and the *Lunulària vulgàris*, so common in German gardens, propagates itself only in this way. In lichens they often burst in astonishing numbers from the leaves, so that the whole surface of the leaf appears to be covered with a granulated powder; and the plants on which this takes place to a great extent scarcely ever seed.

Some time ago, an often mooted subject was again brought forward in these pages, namely, the possibility of the development of sound seed without fructification. The fact, as mentioned by M. Bernhardt, cannot be doubted; the more so, as it appears to me, from what has been said, that such a form of seed, the construction of which may be something between a seed-bulb and a tuber, is possible.

The rudiments of the bud, when they begin to expand, display an independent individuality; not only in the cases we have mentioned, but also when they are developed in any other manner by metamorphosis or art. They show a striking analogy to the seed-bulb, when they appear like little buds in the axils of the leaves of some annual plants which do not usually produce branches, as in *Dentària bulbifera*; and in several species of *Lílium*, *Begònia*, and *Saxífraga*, they appear among the flowers; or, as in some of the begonias, along the whole of the stalk. Rudiments of buds on annual plants that have done flowering may be made to germinate by artificial means. For this purpose, the stalk is cut down to below the part where it has flowered, and then put, like any other cutting, into the ground. In moist and confined air, with the proper degree of heat, these cuttings make no roots at the section in the ground; but the latent buds in the axils of the leaves are developed, and grow into young branches, throwing out at their base a number of roots closely provided with hairs for absorption, and thus become independent as soon as they are developed. These young shoots are then taken off, and treated as cuttings which have already rooted. In this manner, according to my colleague Brauer's experiments, the red-flowered *Lobèlia*, *Gloriosa supérba*, and several species of *Phlóx* and *Dioscòrea*, may be propagated very easily. Some lilies which have no bulb-buds in the axils produce them when treated in this way.

Here may be mentioned, also, the buds which grow sometimes on leaves, or on the edges of leaves. The formation of buds round the edges of the leaves of *Bryophýllum*, when these leaves are laid with the under side on a pot full of moist earth, is well known. The same phenomenon is less known in the genera *Kalanchòe*, *Echevèria*, and *Gloxínia*; and *Echevèria gibbiflòra* has this peculiarity, that the upper leaves possess the

property in a much higher degree than the lower ones; this proceeds merely from their greater age, as, when younger, they form buds as easily as the others. The appearance of these buds takes place at the same time as the roots at the base; as long as the leaves are on the plant they only sprout when the atmosphere is very damp and warm, or when, by making incisions in the leaf-stalk, the returning sap is interrupted. In *Bryophyllum*, they are seated like a conical knob in the axils of the notches, and are connected with the bundle of spiral vessels which form the veins of the leaf.

From this circumstance, the single fruit, or seed-vessel, was said to consist of a fruit-leaf bent over and grown together. In growing together, the pouch was formed which contained the ovula; and this view of the case was applied to all formations of seed, and hypothesis upon hypothesis raised upon it. In the present day this view must be considered erroneous, at least, partly so; as, among the vast number of plants, there are hitherto but few examples known where buds grow on the edges of the leaves. It may also be remarked, that the ovula never proceed from the edges themselves, but from the bundle of vessels lying on them; and we have no right to suppose that these vessels are formed by the growing together of the edges of the leaves, when we see in all other cases in nature that the ribs and veins of the leaf give the direction to its form, but usually end before coming to the edge. Propagating plants by leaves, which was adduced as a strong proof of the validity of this opinion, by no means justifies it; for, when roots and buds are formed (though for the most part they only make roots, and many leaves remain for years together, fill the whole pot with roots, and form no buds; so that, to make sure of succeeding, the axillary bud ought to be removed with the leaf), the latter proceed from immediately above the cut, out of the leaf-stalk, and, except in the above-mentioned cases, never out of the edges of the leaf. I do not, however, assert from this, that fruit cannot be formed without an axis; for Nature does not suffer herself to be trammelled with systems. Should there, however, be such a formation of fruit, which, nevertheless has not as yet come under my knowledge, it must take place apparently, as M. Meyen very justly remarks, from the passing over of the axis into the fruit-leaf; and the ovula would be much more likely to spring from the axils of the veins, than from the edges of the leaves.

That such a form of fructification is possible, but by no means normal, is proved by the circumstance that on many leaves, in favourable situations, buds exactly like those developed from the rudiments of buds have been observed. They were first remarked by Poiteau on the whole surface of the leaf, springing

from the veins of detached leaves of *Ornithógalum thyrsóideum*. Cassini noticed them in the axils of the leaf-stalks of *Cardámine praténsis*; M. Hensler, on the points of the leaves of *Maláxis paludòsa*; Meyen, on the inner and outer surfaces of the scales of hyacinth bulbs; and my colleague, Ludewig, in this garden, on the edge of an oval cotyledon  $1\frac{1}{2}$  in. long and  $\frac{1}{4}$  in. thick. The seed seemed to belong to one of the *Leguminòsæ*, and the cotyledon itself was broken off by mistake from the young plant, and again put into the ground.

Lastly, in the fronds of many ferns, bulb-buds of a similar form are produced, such as in *Aspídium bulbíferum*, *Woodwárdia radicans*, *Acróstichum flagellifórme*, &c., which cannot really surprise us, as these also bear seed. They appear on the back or on the surface, on the middle or side veins, in the notches of the frond or near the edge, as in *Ceratópteris*; but they are always connected with the vessels. Detached leaves of *Hemionitis palmàta*, laid upon moist earth, produce young plants round the edges like *Bryophýllum*.

The perfect bulb lasts either one or more years. Perennial bulbs increase yearly, as those of the lily. The annual, or rather biennial, bulb, after it has blossomed, forms a new one by proliferations at the side, which, as it increases in size, consumes the old bulb, and is ready to flower the following year. We have an example of this in the tulip. The bulb-tuber, or corm, already mentioned, is a modification of the common bulb. According to Link, it arises from the rind of the disk of the bulb becoming exceedingly thick, instead of assuming the leafy form which only appears as thin scales, as in *Ixia*, *Gladiolus*, *Cròcus*, &c.

The tuber is the last form by which propagation is very readily effected. Tubers are formed from a change which the buds, more or less in number, undergo with the underground stem. The pith, and the outer coat of the stem, increase much in size at the same time; and as many rudiments of buds as there are of the small scaly leaf attached to the parts about to be transformed (which leaf is usually scarcely perceptible with a magnifying glass), so many eyes are formed as rudiments of young plants in the tuber. In this case, the individuality of the bud has been long known; and hence has arisen the custom of cutting out the eyes of potatoes, and planting them in the ground instead of the whole tuber, by which process each is developed into a young plant, nearly in the same way as a bulb-bud. Potato plants produce their underground stem, from which the tuber is formed, from the base of their main stem; therefore, as soon as the young plants have attained a certain height they are hoed up, which increases their growth and number. Only those tubers which are formed by the above-described transformation,

and have eyes, can be considered real tubers; *Tropæolum tuberosum*, *T. tricolorum*, *T. pentaphyllum*, *Heliánthus tuberosus*, &c. The enlarged roots of the Scitaminææ, of *Cyrilla*, and *Trevirana*, are only, in fact, proliferous side roots; the bent knobby root of *Gloriosa* proceeds from an underground stem, but can only produce a bud at one end of it. The roots of *Batatas*, *Gloxinia*, *Gésnera*, *Dahlia*, &c., are merely enlarged roots, and, when divided, must have a part of the neck, or collar, of the root attached, which alone has the property of producing buds.

(*To be continued.*)

---

ART. IV. *On the Importance of the Study of Natural History to Gardeners.* By PETER MACKENZIE.

FEW will deny but that the study of natural history is advantageous to all who engage in it, but more especially to the gardener: to him it is of solid benefit, without bringing into account the unalloyed delights that accompany the study of the design, and order, and balance, that are to be found in the wide field of created objects. This is a subject that has been recommended in this Magazine from its commencement to the present time, and I hope that it will never be lost sight of while this periodical exists, and may that be as long as the present order of things remains! Every department of natural history has its admirers and cultivators; the time has gone past when it was held in low estimation; and the means are daily increasing whereby we may be made acquainted with the gigantic and minute objects that abound upon our world. The facilities that now exist enable man to proceed in the way of knowledge at a rate unknown to those who have gone before us, and we must have ourselves to blame if we do not lay hold of the opportunities that are offered for our help.

The zoological systems of Linnæus and Cuvier place man at the head of the whole arrangement: in the one he is found in the order Primates, genus *Homo*; in the other he occupies alone the order Bimana. This part of natural history is not studied with the attention which its importance demands. I think it has the appearance of something unnatural, to hear gardeners and others talking about systems of inanimate matter, and cannot tell of their own standing in the world of life and being. It is something like a man setting himself up to teach the geography of the moon, who knows nothing about the topography within the branch of the apparent horizon by which he is surrounded. It is all very well for gardeners to know something of vegetable physiology, such as cellular tissue and all the



other tissues that belong to vegetables, and the means by which plants perform their vital actions; to be able to tell what they feed upon, to know of their digestion and respiration, as well as the circulation of the fluids that takes place within them; all these things, and many more, are of importance for gardeners to know: but to know these things, and remain ignorant of the structure of his own body; to know nothing of the cellular, muscular, and nervous tissues of which that body is composed; in fact, to know more about the *Mónas Térmo* than he does of himself, is doing an injustice to himself and posterity. Such knowledge is of too great importance to be left entirely in the hands of physicians and surgeons. It is said by a writer on animal physiology, "that the science of life is perfectly open to the student of nature, to the cultivation of which he may approach without the apprehension of meeting with any extraordinary difficulties. The obvious and peculiar advantages of this kind of knowledge are, that it would enable its possessor to take a more rational care of his health; to perceive how certain circumstances are beneficial or injurious; to understand in some degree the nature of disease, and the operation as well of the agents that produce it, as of those that counteract it; to observe the first beginning of deranged functions in his own person; to give to his physician a more intelligible account of his train of morbid sensations as they arise; and, above all, to cooperate with him in removing the morbid state on which they depend, instead of defeating, as is now through gross ignorance constantly done, the best-concerted plans for the renovation of health."

Passing from the solids and fluids of the human body, there is something else that ought to occupy the attention of the gardener who has the desire of improving himself, namely, the history of the human mind. This is a subject which every rational creature ought to be made acquainted with. It is surely of importance to know the extent and capacity of that mind that is planted within man, when, by means of it, he may, step by step, arrive at that justness and truth of understanding which is the great perfection of a rational being; yet how many thousands are ignorant of its operations, and regard it as a thing of no value, resigning the study of it, without any cause, into the hands of the professors of logic!

It is a common complaint with some gardeners, that they have not the means within their reach for improving their minds. The complaint, in some cases, may be just; but I would ask the question, Do they employ the means and opportunities that are within their power to the best advantage? Is it not a common practice with many gardeners, and Scotchmen among the rest, in the neighbourhood of large towns, to meet upon a Sabbath, and, instead of seeking to hold converse with their

Maker, either in his works or in his word, hasten away to some gas-lighted tap-room, and there talk of their patriotism amidst the fumes of alcohol and tobacco? and in their cups they will not forget to say,

“ Here’s to gude auld Scotland yet;”

and continue their bacchanalian carousal until they are scarcely able to lift the pot to their mouth, or reach their arm across the narrow table, and say, being unable to sing,

“ Come, gie’s your hand, my trusty friend,  
And there’s a hand o’ mine,  
And we’ll tak’ a right gude wally waught  
For auld lang syne.”

Such men, by continuing such habits, soon become a pest to the profession they belong to, and a disgrace to the country that gave them birth. The continuation of scenes that would shame Pandemonium must soon make unwelcome inroads upon their weekly earnings, and undermine a framework that contains a gem that, by proper culture and training, might have proved a blessing to themselves, and an ornament in society, instead of being looked upon as the vilest weed, and shunned by their fellows as they would shun an ophidian reptile.

How different is the example of such men as the founders of the West London Gardeners’ Association for mutual Instruction! These men will enjoy the luxury of doing good, and make true that saying of holy writ which is spoken by Solomon, “ There is that scattereth, and yet increaseth:” while they impart knowledge to others, their own minds will become more fruitful. What a contrast there is between the men who are willing to raise their fellow-men to honour and dignity, and those who have to cast up their accounts in Newgate, and pay their reckoning in the hulks or Norfolk Island! I intended to say a few words in commendation of mutual instruction societies among gardeners; but, as my sheet is full, I must leave it to another opportunity.

*West Plean, Nov. 5. 1841.*

---

ART. V. *Notice of a comparative Trial of the Qualities of various pure Earths for supporting Vegetation, made in the Gardens of Messrs. Drummond, at Stirling.* Communicated by Messrs. W. DRUMMOND and Sons.

OATS sown in the middle of April, reared in pots 8 in. in diameter, three plants in each, and plunged to the rim in an open border, cinders being put under them, and care otherwise taken that the roots should obtain no extraneous nourishment. The

plants were watered a few times in very dry weather. The stalks were in general about 3 ft. in height. The grain fully ripened.

| Earths.   | PRODUCE. |   | Ears. | Grains. |
|---|----------|---|-------|---------|
|   |          |   |       |         |
| Granite (Aberdeen)                                      | -        | - | - 13  | 220     |
| Clay-slate (primitive)                                  | -        | - | - 11  | 241     |
| Greenstone, secondary trap                              | -        | - | - 10  | 245     |
| Limestone, tertiary formation                           | -        | - | - 9   | 251     |
| Chalk   | -        | - | - 13  | 355     |
| Gypsum (very sickly plants)                             | -        | - | - 6   | 40      |
| Sandstone, of the newer formation                       | -        | - | - 12  | 230     |
| Pit sand, brown siliceous                               | -        | - | - 10  | 210     |
| Blue clay from a tilled field, 10 ft. under the surface | -        | - | - 10  | 242     |
| Mixture of the above                                    | -        | - | - 9   | 190     |
| Common light loamy soil                                 | -        | - | - 18  | 453     |

These experiments seem worthy of further prosecution, particularly relative to the respective influence of the atmosphere and soil on vegetation, in the furnishing and assimilating of the food of plants. The oats were sown at our nursery grounds in the middle of April, and ripened in the beginning of September. *Stirling, Nov. 13. 1841.*

---

ART. VI. *The Landscape-Gardening of F. L. von Skell of Munich.*  
Translated from the German for the "Gardener's Magazine."

(Continued from p. 505.)

X. *On tracing and staking out Streams and Brooks.*

1. WHENEVER a stream exceeds 100 ft. in breadth it no longer belongs to the garden, both on account of limited space, and the necessary expense that would be incurred; and also because streams of a much less magnitude are more adapted for a garden, and afford more charms and pleasure: but if the landscape-gardener does not wish to have such streams, he should take care that his garden is not totally without water; because that is to be without life.

Water is the soul of gardening; and, where it is to be found, there is also Philomel and all the other vocal choir of the forest. There nature is decorated with her liveliest colours, and the children of Flora appear in parti-coloured attire by the side of the murmuring brooks.

2. The broad streams must have quite another course from the smaller streams, and the broader they are so much the larger and majestic should the line of the stream be; therefore, only powerful obstacles should prevent it from running in another direction. It is quite the reverse with smaller streams, as the most trifling impediment is quite sufficient to turn them to the right hand or the left; and this is the reason that in nature

small streams have so many tortuous windings, which particularly distinguish them from large rivers. In staking out the broad river, therefore, the landscape-gardener should form the outline in a noble style, with bold and powerful bendings, but not with a too frequent repetition of wavy lines.

The lines of both sides of the river and the rivulet ought never to be made exactly parallel, and the same form of outline ought never to be repeated; as Nature, even here, is true to her principles, and these should always be imitated by art.

If, therefore, the right bank of the stream makes a powerful bend outwardly, the left bank of the stream must make the same inwardly, into the stream itself; but these bends should not always be exactly opposite each other, but more or less above or below, and always varied in form, if you faithfully imitate Nature in these rivers, and wish to have your work considered as part of hers.

3. Although the low banks of a river or brook have seldom a romantic character, they are much to be preferred in a garden to those that are high and steep; because they present a greater surface of water to the eye, and are not so liable to have the banks give way, which not only has a terrific appearance, but is extremely dangerous to the passers by. But by high banks we do not mean those which have been formed in the rocks by nature or art, and covered with the most beautiful shrubs. Such banks are of great importance in the rural landscape; because they give a character of solidity and strength, and form a contrast to the objects of an opposite character by their impending cliffs and continued variety of shade, and by the very numerous assemblage of forms and colours which they display: therefore, banks of such a character cannot be too often introduced. No bays or outlets ought to be formed in rivers, such as are seen in lakes, as this would give the idea that the stream wished to open to itself a new course, and for this purpose had broken its banks.

4. Rivers very seldom have any islands, and when this is the case they should never be placed quite in the middle. They are generally of a longish form, and placed somewhat near the side of the river, and they should be rather narrower in form at both ends.

5. These rivers, brooks, lakes, and ponds must be traced out by the tracing-staff, and as much as possible in imitation of such lines in nature; and, as the earth must here be dug out, it will not do to have it done at random. When the principal outline has been traced and staked out, attention must be paid to local character, and to natural artistical effect.

6. There are cases in which imposing streams can be made to appear in a garden with but a small supply of water, and this is done by deception. Such artificial productions can only deceive

the eye to a certain extent, such as to the point where the stream seems to be checked by an impenetrable thicket, and appears beyond, as a small brook which had produced the supply. When the eye can no longer follow the course of the stream on account of the deep rocky abysses overgrown with thorns, the imagination has the fullest liberty to indulge in its own creation. When there is but a scanty supply of water for such an undertaking, and the extent it is to cover is great, none, if possible, should be allowed to escape, through the soil of the bed or banks of the stream, a circumstance which might be prevented by its having a loamy bottom. In the garden at Blenheim, in England, a majestic stream is produced by means of this successful deception, and it is greatly increased by the sight of a large vessel lying at anchor. But such an illusion is not easily effected; the slowly gliding stream soon awakens suspicion, and I can, therefore, only advise my readers to venture on such an undertaking in the most extreme cases, because it but very seldom succeeds.

7. The character of smaller streams, as it has been already stated, is, that they are more tortuous in their forms according to their breadth; that is, that their serpentine lines are more frequently repeated than those of larger rivers. The windings of these small streams always seem more natural when the real or apparent causes of them frequently present themselves. When the windings are extensive, therefore, some large trees, groups of low shrubs, or portions of rock, should be introduced, to give this appearance.

When these streams are only 4 or 6 feet broad, they frequently become divided, and leave a long tongue of land in the centre, which nature usually decorates with flowers. It must be observed, that large streams never have an equal breadth: the right bank of the river, also, is as unlike the left bank, as the windings of the serpentine lines which describe the form of these brooks are similar to each other.

The best method of tracing and staking out such streams is, first, to form the principal line, with its grand windings, by stakes, or by a slight furrow in the ground, and then to make all the smaller tortuous windings on the line itself, on the right and left bank; after which the first mark should be effaced.

Nature also lends a helping hand, and assists imitative art in making the banks resemble her. In staking out these small streams, they should frequently be made to approach the road where they can be seen; they should then seem to penetrate into thick overgrown bushes, and in other places re-appear with a gentle murmur. This frequent repetition has a delightful effect in nature; it awakens the most enthusiastic feelings, and we can only quit such scenes with an earnest desire of revisiting them.

*(To be continued.)*

ART. VII. *On different Modes of glazing Hothouses, Pits, &c.* By JAMES SEYMOUR, Kitchen-Gardener to the Countess of Bridgewater.

THERE are few subjects on which gardener's differ more than the glazing of plant structures. In some old gardens there are several sorts of glazing to be found, both as to the shape and size of panes. Some gardeners are advocates for large panes, as they give more light by not having so many laps as the small ones; but I do not like the large ones for several reasons. In the first place, they are more likely to be broken by moving the lights in giving air, and with hail storms, frost, &c.; and, secondly, when there is a pane broken, it lets in much more air than a small one, besides costing more to replace it

Suppose a vinery or peach-house to be glazed with panes 10 in. deep by  $6\frac{3}{4}$  wide, with an unputtied lap, it will be found after a severe winter that many of the panes are split up the middle, and that when taken out they are only fit for patching, work which, at all times and in all structures, looks very unsightly. I have had an early vinery of this description under my charge, and well know the inconvenience of large panes. I have very often thought there ought to be three or four sizes of panes used in horticultural structures; say the largest size for vineries, peach-houses, fig-houses, &c.; the next size for pits for growing pines, melons, cucumbers, &c.; the next size for frames; and the smallest size for hand-glasses.

In many of the gardens it will be found that the vineries and pits are glazed with the same-sized panes, so that when any of the panes come to have a corner broken off, they must be removed to insure the house being kept dry, and when they are taken out, they cannot be used in the pits, on account of their being the same size; but, had the panes in the pits been of a smaller size than those of the vinery, then, in all probability, they would have come in well without much loss.

Suppose there were a regular repair going on in one of the vineries, a great many of the panes will be found blemished and not fit to remain, but they would still be found large enough for the pits and frames without much loss.

When there is a general repair going on with the hothouses, the glazier ought to begin with the largest-sized pane first, and work down to the smallest, and not, as frequently is the case, cut a large piece of glass to replace a small one.

In my opinion there are no better-sized panes for hot-houses than 7 in. wide by  $4\frac{1}{2}$  deep; for pits,  $4\frac{5}{8}$  by 3 in. deep; for frames, 4 by  $2\frac{1}{2}$  in. deep, &c., with a lap of  $\frac{1}{8}$  of an inch: the glass to be clear, stout, and selected as flat and even as possible, so that the laps may be perfectly in contact one upon

the other. The panes must be cut so as that they do not fit too tightly against the sash-bar (a point too frequently neglected by some glaziers); they should have room left for the bars or ribs to swell and expand. Before a light is glazed, all the panes should be laid in loose, to see that they lie even and quite flat, as well as range one with the other; and, when that is done, the panes must be taken out, and some well worked putty laid in the rabbet; the panes must then be replaced and pressed firmly down, and the bottom pane bedded in the putty so as not to leave a vacuity.

In the spring of 1838, we had, at this place, occasion to rebuild two old metallic vineries; they were rebuilt with cast iron by Messrs. Barwell & Co. of the Eagle Foundry, Northampton. They were glazed with panes  $4\frac{3}{4}$  in. by 3 in. deep, with selected and perfectly flat glass, direct from the glass-house, packed in boxes that contained about 500 panes in each box, and put in by the glaziers as I have described above.

The houses are heated by flat hot-water pipes. There are three lights in a range upon the roof; the two bottom ranges, and the corner ones of the top range, are secured down with pins and putty: all the other top lights are movable, and managed by a windlass. The front sashes are hung upon hinges, and all open outwards. We can give what air we wish by a rod of iron attached to the sash, with holes in it; and in the sill there is a pin to fasten the rod to. One corner is taken off each sash for the purpose of taking in or out vines when required. There is a piece of cast iron to fit into the corner of the sash, which is fastened by two screw nuts, to keep the stem of the vine in its place. The doors are made of wood, as they are easier kept in order than iron ones, and much lighter to open. The roof of these two houses contains about 9216 panes; the two ends and partition, 1579 panes; and the front sashes, 1920 panes; with three doors that contain each 20 panes 5 in. wide by 7 in. deep, making a total of 12,775 panes. From the spring of 1838 to the present time (Oct. 1841), there have only been 10 panes broken in the roof by the frost, &c., and 12 in other parts by accidents. This house requires shading in hot clear weather.

In November, 1838, several of our lights were thrown off a pine-pit by a strong gale of wind, and several panes broken; but one light was so very much broken, that I had it reglazed with panes 7 in. wide by  $4\frac{1}{2}$  in. deep, and the lap  $\frac{1}{8}$  in., and glazed, in other respects, as I have recommended above. The light is 8 ft. long by 4 ft. wide; it contains 132 panes, and is in constant use, being a bottom light; having pots of kidney-beans placed upon the flue all the autumn, winter, and spring. The lights are frequently moved, and consequently liable to accidents. There have only been two panes split by the frost,

and one broken by accident, up to the present time (Oct. 1841). The size it was glazed with before was 7 in. wide by  $8\frac{1}{2}$  in. deep, and an open space left between the panes; and the laps were  $\frac{1}{4}$  in. deep. The sacrifice of glass and plants by frost, and by letting in the cold air, was considerable; but as one of the panes got broken, I had it replaced by two. There used to be a great many broken at the bottom of this pit by the frost; the laps being all left open with a view of letting out the condensed steam that run down the ribs, &c. I have had the whole of the bottom panes taken out, cut in two, and bedded in putty; so that now I have rarely one broken by the frost, as there is no water to congeal. This method of puttying the laps, I find, very much strengthens the glass.

I should be glad to hear the experience of others on the subject of glazing; and I also should like very much to see some remarks on the handles and fastenings of hothouse lights, as almost every gardener has his own method.

*Frithsden Gardens, Ashridge Park, Herts, Oct. 18. 1841.*

---

ART. VIII. *Report on the new Species and Varieties of Hardy Trees and Shrubs raised in the Horticultural Society's Garden, since the last Report made in November, 1840, and published in the "Gardener's Magazine" for that Year, p. 631. Drawn up for the "Gardener's Magazine," by George Gordon, A.L.S., Superintendent of the Arboretum, by Permission of the Council of the Horticultural Society.*

I. *Plants raised from Seeds received from Dr. Royle, and which are certainly true to the Names sent with them.*

*SYRINGA Emòdi Wall. Cat. No. 2831.; Don's Miller, vol. iv. p. 51.; Royle Illust. vol. i. p. 267., and t. 65. fig. 2.; and Arb. Brit., abridged edit. fig. 1244.—Leaves elliptic-oblong, glaucous beneath, attenuated at the base, and acuminate at the apex. (G. Don.) A handsome deciduous shrub from 8 ft. to 10 ft. high, native of Kamaon towards the Himalaya, with purple flowers, resembling S. Josikæ'a.*

*Cárpinus vimínea.*—Found in Nepal, Kamaon, and on Mussooree, at an elevation of 6500 ft. (*Royle Illust.*, vol. i. p. 343.)

*Limònia Laureòla.* Pl. As. Rar. t. 245.; *Royle Illust.* p. 130.—The only plant of the family of the Aurantiacæ found on the tops of cold and lofty mountains in the Himalayas, where it is for some months of the year buried under snow.

*Cotoneáster bacillàris Wall. ined.; Lindl. Bot. Reg. No. 1229.; and Don's Miller, vol. ii. p. 603.—Leaves obovate, drawn down into the petiole, glabrous. Cymes many-flowered, divaricate, and, as well as the branches, pilose. (G. Don.) A deciduous shrub from Kamaon.*

*Euónymus? crenulàta Wall. Cat. 4297.*



*Ligustrum? vestitum* Wall. Cat. No. 6304.—Considered by some as a variety of *L. spicatum*, but with the thyrse more crowded, and more densely hairy, as well as the young leaves, branchlets, &c. (*Don's Miller*, vol. iv. p. 45.)

II. *Plants raised from Mexican Seeds received from M. Hartweg.*

*Quercus Skinneri* Benth.—A very remarkable species, having the fruit of most unusual size, with the external appearance of an acorn, and with the internal structure of a walnut. It is described as a noble tree, from 50 ft. to 70 ft. high, occurring on the slopes towards the Pacific, among the mountains of Acatenango, Medio Monte, and Quezaltenango. (*Gard. Chron.*, vol. i. p. 116.) The foliage and male flowers said to be precisely as described and figured in *Q. acutifolia* Nees. [*Q. acutifolia* is figured and described in our *Arb. Brit.*, vol. iii. p. 1947. It has leaves cordate lanceolate, very finely pointed; beset on the margin with large mucronate teeth; brownish beneath; tomentose near the veins; and much more like those of a sweet chestnut than of an oak.]

*Rubus trilobus* Moc. et Sess. Fl. Mexican. ined., Dec. Prod. 2. p. 566., *Don's Mill.* 2. p. 540., *Plantæ Hartweg.* No. 456.—Stem erect, branched, glabrous; branches, petioles, and peduncles hispid. Leaves 3-lobed, unequally serrated, villous; lobes acute, serrated, lateral ones diverging, middle one the longest; stipules and bractæ lanceolate, villous. Flowers solitary at the tops of the branches; calycine segments ovate, concave, spreading, rather foliaceous and spatulate at the apex, longer than the petals. Carpels numerous, subglobose. (*Don's Mill.*, vol. ii. p. 540.) A shrub from Mexico, with large white flowers and purple fruit.

*Pinus oöcarpoides* Lindl.—A pine from Guatemala, with very long slender leaves, five in a sheath, and cones about half the size of those of *P. oöcarpa*, of which it is probably a variety.

*Polygonum volcánicum* Benth., *Plantæ Hartweg.* No. 562.—A suffruticose species, with thick fleshy leaves, and flowers often solitary. A native of Mexico, on the summit of the volcanic mountain Xetuch, near Quezaltenango.

*Arctostáphylus nitida* Benth., *Plantæ Hartweg.* No. 483.—An erect shrub, with oblong-lanceolate acute leaves, smooth on both sides and shining above. Native of the Carmen Mountains.

III. *Plants raised from North-West American Seeds.*

*Ceanòthus velutinus* Douglas; Hook. Fl. Bor. Am. 1. p. 125. t. 45.; Torrey and Gray's *Flora*, vol. i. p. 265.; and *Arb. Brit.* abridged, p. 181. and fig. 274.—A shrub from 3 ft. to 8 ft. high, with branches somewhat pendulous. Leaves orbicular, elliptical, or elliptical ovate, obtuse, sub-cordate, glandularly crenate, ser-

ruled; coriaceous, glabrous, and shining (as if varnished) above; velvety, canescent, and strongly 3-ribbed beneath. Panicles axillary, elongated, on rather long peduncles. Found on sub-alpine hills near the sources of the Oregon, and at the Kettle Falls. (*Torrey and Gray.*)

---

ART. IX. *The Flower-Garden at Esholt Hall, Yorkshire, the Seat of W. R. C. Stansfield, Esq., M.P.* By J. PRINGLE, late Gardener there, now Gardener to the Right Honourable Lord Feversham, Duncombe Park.

ESHOLT HALL, the seat of W. R. C. Stansfield, Esq., M.P., is a regularly built stone edifice, having on three sides of the building an elevated terrace, enriched with vases, urns, &c., from which a walk leads to the central entrance of the flower-garden, which is the subject of the present communication. Part of the garden I laid out in the year 1833, and completed it, according to the plan herewith sent (*fig. 55.*), in 1837.

The ground is nearly on a level surface, with a slight inclination to the east, having a wall on the north side, 8 ft. high and 100 yards in length, against which are planted different varieties of China roses, and various creepers and half-hardy shrubs. On the east and west ends of the garden there is grass (not shown on the plan for want of room) to the extent of the wall, on which are planted hardy flowering shrubs, each shrub having a circle dug round it proportionate to the size of the plant; and these circles are chiefly planted with early flowering bulbs, as crocus, snowdrop, narcissus, &c.

All the walks are gravelled, and the beds surrounded with box, which is kept very low by frequent clipping. When the garden was formed, drains were cut in different parts of the ground 2 ft. below the surface, and the walks made from 1 ft. to 15 in. deep, and filled to within 3 in. of the surface with broken stones or brick rubbish; each walk acting as a drain to the adjoining bed. There are small grates placed in the walks over the main drains, which take away all the surface water, and render the walks quite dry and firm to walk on in wet weather, or after a shower of rain. The soil was either entirely taken out to the depth of 15 in., or mixed with compost suitable for what was intended in each bed; and annually afterwards the beds underwent a partial renewal of soil, to suit the change of arrangement which I made with the greenhouse plants and annuals; and, as I grew the dahlias every year in the same places, I took a quantity of soil entirely out where the plants had grown, and replaced it with fresh compost every season. Most of the beds have patches of bulbs, or low-growing early flowering plants, planted about 6 in. from the box, and at regular

distances, according to size; and in the following list these will be named as edgings in the arrangement of each bed, which was that adopted in 1837, and, I believe, gave entire satisfaction to my then respected employers.

As I cannot sufficiently explain the planting of the beds without causing confusion on the plan, I shall give some of the beds on a larger scale, marking more particularly the system I have adopted in the general planting and arrangement of the beds, which, from No. 1 to No. 8, are all similarly arranged; therefore the bed No. 1 may serve as an example for the whole.

1, *a*, *Pæonia* arborea; *b*, *Escallonia* rubra, &c.; *c*, crocuses, snowdrops, winter aconite, dog's-tooth violets, *Scilla* bifolia, &c., planted near to the edge of the bed; *o* bulbs; + herbaceous plants.

Herbaceous plants, planted 1 ft. from the edge of the bed; with different species of *Narcissus* planted close behind every fourth plant.

The herbaceous plants are from 1 ft. to 2 ft. in height, and are varied as much in each bed as the number of species in the collection would allow.

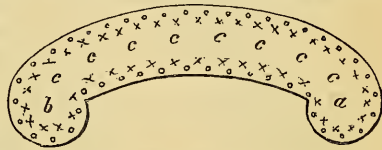

Fig. 53. Beds from No. 1. to No. 8.

Some may think that the beds would be crowded with plants, but such has not been the case, as the bulbs have chiefly done flowering before the herbaceous plants have made much growth, and the herbaceous plants are nearly all over before the dahlias are in full bloom; which arrangement has insured a succession of flowers from the first fine weather in spring until the frosts kill the dahlias in autumn.

9, 10, 11, and 12 are severally planted with moss, perpetual, and select deciduous roses, marked *r*; and different varieties of herbaceous pæonies, marked *p*; with three patches of white lily marked *l*, in each bed.

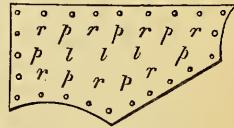

Fig. 54. Beds from No. 9. to 12.

9 is edged with *Primula* farinosa and *Gentiàna* septémfida.

10, Edged with *Gentiàna* acaulis.

11, ditto, ditto. 12, Edged with double primroses.

As soon as the pæonies have done flowering, China aster or Russian stocks are planted in front of each pæony for an autumnal bloom.

13, Common China roses, edged with *Aurícula*, of varieties.

14, Noisette roses, trained on a flat trellis, and edged with *Eránthis* hyemàlis.

15, Common China roses, edged with *Hepática*, of varieties.

16, Noisette roses, on a flat trellis, and edged with *Muscari* botryoides.

17, *Azàlea* póntica globosa in the centre, with *Galánthus* nivàlis around the plant; then a circle of *Mímulus* ròseus, and the bed edged with alpine aurículas.

18, *Kálmia* latifolia in the centre, surrounded with crocuses, and edged with double primrose, and planted with *Lobèlia* grácilis for the summer.

19, Similar to No. 17, with *Lobèlia* grácilis for summer.

20, Similar to No. 18, with *Verbèna* *Meléndris* for summer.

The beds from 21 to 28 are all edged with different varieties of *Cròcus* and heartsease alternately, and were planted for summer flowering as follows:—

21, Scarlet geraniums. 22, *Sálvia* Gràhami and angustifolia.

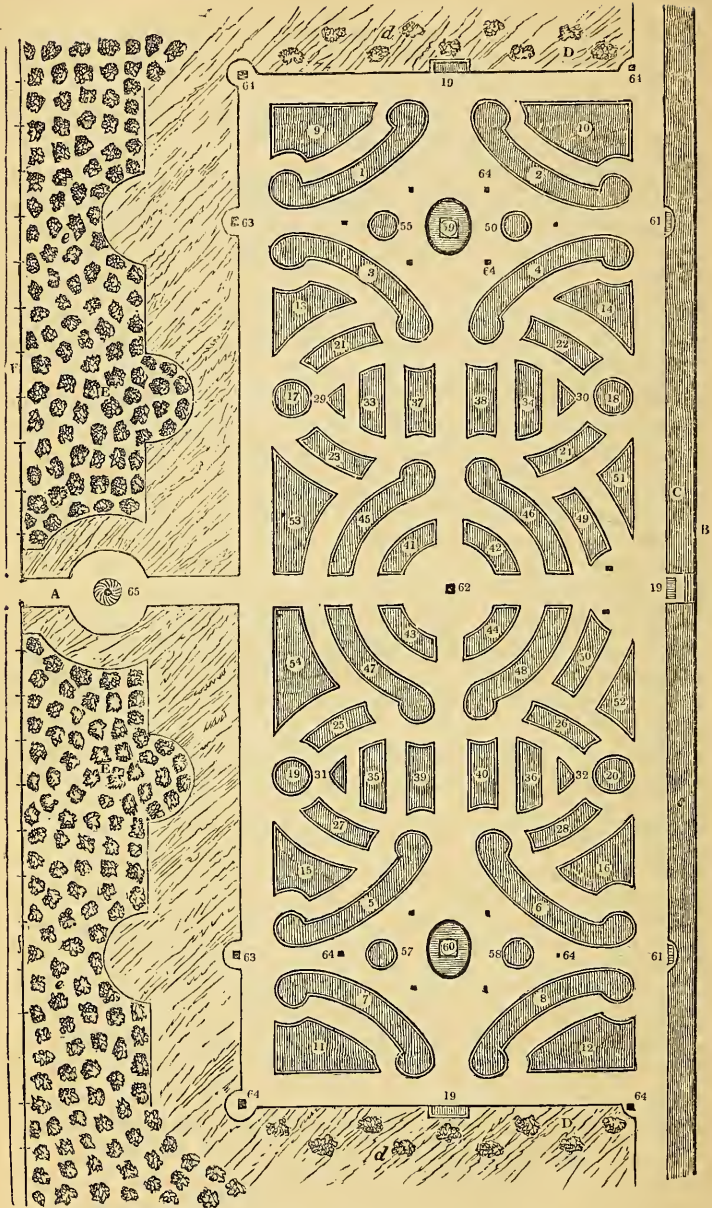

Fig. 55. Flower-Garden at Esholt Hall.

- 23, *Petùnia nyctaginiflora*. 26, *Nierembèrgia phœnicea grandiflora*.  
 24, *Sálvia fùlgens*. 27, *Lobèlia fùlgens*.  
 25, *Mímulus cardinàlis*. 28, Shrubby *calceolarias*.  
 29, *Ròsa minor*, edged with *Hepática*, and sown with *Gilia tricolor*.  
 30, Dark China roses, edged with *Saxifraga granulàta*, and sown with *Kaulfússia amellòides*.

- 31, Select China roses, edged with *Saxifraga granulàta*, and sown with *Collínsia bicolor*.  
 32, Tea-scented roses, edged with *Hepática*, and sown with *Nemóphila insignis*.

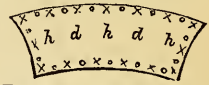

Fig. 56. Beds from No. 21. to No. 28.  
*h*, White lilies. *d*, Dahlias.

- 33, Choice tulips and German asters.  
 34, Double tulips and *Chryséis cròcea*.  
 35, Double anemones and *Lasthènia glabràta*.  
 36, Double anemones and German asters.  
 37, Edged with choice heartsease and mixed choice pelargoniums.  
 38, Ditto, ditto.  
 39, Edged with choice heartsease and mixed greenhouse plants.  
 40, Ditto, ditto.

- 41, Jonquils and *Alonsòa lineàris*.  
 42, *Ranúnculus* and *Heliotròpium peruviànium*.  
 43, Jonquils and *Nierembèrgia grácilis*.  
 44, *Ranúnculus* and *Calceolària penduliflora*.

- 45, *f*, A fuchsia in each bed, surrounded with a circle of *Eránthis hyemàlis*; and, nearer the margin, a circle of dwarf larkspurs; *o*, patches of *Anemòne Pulsatilla*, *apennìna*, and other species; *l*, patches of different varieties of martagon lilies. *d*, dahlias for summer and autumn bloom.

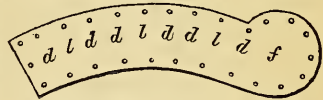

Fig. 57. Beds from No. 45. to No. 48.

- 49, Bulbous *Iris*, and *Agathæa cœléstis*.  
 50, Bulbous *Iris*, and *Senècio élegans fl. pl.*  
 51, *Tigrídia pavònia*, edged with *Campánula pùmila*.  
 52, *Gladiolus psittacìnus*, edged with *Campánula pùmila*.  
 53, American plants, edged with double primroses.  
 54, Ditto, ditto.  
 55, *Azàlea coccínea*, edged with *Gaulthèria procúbens*.  
 56, *Azàlea coccínea*, edged with *Gaulthèria Shállon*.  
 57, *Rhododéndron pónticum*, edged with *Heliánthemum* of var.  
 58, *Rhododéndron pónticum*, edged with *Erica herbàcea*.  
 59 and 60, Tazza vases, which serve as dropping fountains during winter, and in the summer season with the jets, &c. of the late Mr. Rowland.  
 61, Seats. 62, Sundial. 63, Statues.  
 64, Vases, which are all elevated on stone plinths, proportionate to the size of the vase, and are filled with flowering plants during the summer season.

Having extended the present communication to a greater length than I at first intended, I shall only briefly remark that every attention is paid to tying up each plant as required to one, two, or more stakes; pegging down to the ground, or training them in whatever way is most suitable to the habits of the plant; cutting out all decayed flowers that have done blooming; and keeping the whole of the garden in as much order and neatness as possible.

*Esholt Hall, August, 1838.*

ART. X. *Pomological Notices; or Notices of New Fruits, and Culinary Vegetables, which have been proved in the Horticultural Society's Gardens to be worthy of general Cultivation, since the last Report given in the "Gardener's Magazine" for 1837.* By ROBERT THOMPSON, Superintendent of the Fruit Department in the Garden; by Permission of the Council of the Society.

THE varieties of fruits known to possess first-rate excellence are so numerous, that only those of extraordinary merit require to be now brought into notice. Many new varieties might be mentioned as being good, but those superior are but few. The Dunmore pear is of large size and excellent quality, its season preceding that of the Marie Louise. Groom's Princess Royal pear is of middle size, roundish shape, melting, and valuable on account of its keeping till March. The Ickworth Impératrice plum is somewhat larger than the old Impératrice, of a purple colour, beautifully traced with a profusion of golden-brown lines; the flesh is rich, and the fruit possesses the property of keeping long fresh, and ultimately becoming like a prune, when placed in a dry situation. The Walburton Admirable peach resembles in appearance the Late Admirable, but it ripens better in bad seasons like the present. Wilmot's new Hamburgh grape produces larger fruit than the Black Hamburgh, and has, in consequence, a noble appearance; but its flavour is said not to equal that of the Black Hamburgh. Several new strawberries have been brought into notice, amongst which Myatt's British Queen is likely to take the lead. It is of very large size, roundish and rather flattened in form, and of good flavour considering its large size. Myatt's Eliza, Newsom's Princess Royal, Wilmot's Victoria, Swainston seedling, and the Bishopswick strawberry, are other new varieties considered worthy of cultivation; as are also the Victoria raspberry and Cox's Honey raspberry.

A collection of fruit trees has been received by the Horticultural Society, from Mr. Barker of Suedia, in Syria, consisting of peaches, nectarines, apricots, and the dwarf apple of Armenia. The latter is said to grow to not half the size of the dwarfiest European varieties; and some of the stone fruits are described as having sweet kernels. Such of the above as were alive on their arrival have done well; but the greater part were dead, in consequence of having been long packed and dried up during an indirect passage.

Amongst kitchen-garden vegetables, Marshal's Dwarf Prolific bean deserves recommendation: it is earlier and more prolific than the Early Mazagan. The Milford Marrow pea is a very abundant bearer; the peas are unusually large, and, at the same time, of a green colour. The most unique addition to the culinary department is the *Oxalis Dépezi*, which is

capable of being grown in rich sandy soil, so as to produce good-sized roots, delicate when cooked.

---

ART. XI. *On Root-Pruning Fruit Trees ; with some Remarks on the blossoming Principle, more especially in Chrysanthemums.* By ROBERT ERRINGTON.

I SEE, by some of the horticultural periodicals, that the gardening world has at last become alive to the utility of root-pruning fruit trees in cases of over-luxuriance. The merit of the invention is claimed, I perceive, by or for Mr. Rivers of Sawbridgeworth. Now, on referring to the *Gardener's Magazine*, for Dec. 1830, p. 693., a paper will be found by me on the subject at that early period. I have not any very particular anxiety as to who may gain the merit, not of the invention, but the application of it generally ; yet, as I rather love fair play, I should like the "saddle on the right horse," if possible. I have vol. ii. 2d series of the *Hort. Transactions* now before me, in which, at page 471., is an article by Mr. Rivers, in which he says "it is about ten years since he attempted the thing." Now, whether he had seen my paper or not, I cannot say, but the plan has now assumed the title of Mr. "Rivers's system." I can only say that I have pursued the plan systematically ever since, and can bear ample testimony to the propriety, not to say necessity, of the plan. Shallow planting, which I call the fundamental principle of acclimatising, in original maiden loams, will in a great degree prevent the necessity of root-pruning ; but many cases will arise in moist seasons and cool summers which will call for that process. It is quite evident to me, that if we cannot furnish the necessary degree of heat, and more especially of solar light, we must in proportion abstain from the use of stimulating manures.

We are so far scientific that we can measure and apportion our heat in-doors by our thermometers, but, with regard to atmospheric moisture and light, we continue to grope in the dark. It is true we cannot command light, but we can regulate the supply of food in proportion to the light. In many plants it appears necessary that the growing principle become almost stationary for a time, in order to induce the principle of fructification. As an instance of this, I would adduce the various fruit trees, the pine-apple, and the Chinese chrysanthemum, with a multitude of others. I have some tender Flemish pears, which a few years since lost the points of the young shoots every autumn ; they went black, and shriveled. This I attributed to a late supply of immature wood. In some I bent the branches down, in others I cut the roots, and both plans produced the desired effects, inasmuch as they induced an earlier period of rest. But for a

complete remedy we should go to the fountain head ; plant shallow in pure maiden loams, and reserve the manures for our celery and cabbages, where it can scarcely be misapplied. Those who adopt this mode will scarcely know what the mildew in peaches means. I plant all my wall trees on a substratum of bricks or stones, allowing only 9 in. of soil above the bricks, and the roots immediately in contact with the bricks.

The Chinese chrysanthemum has always struck me as a remarkable plant, and calculated to throw much light on the blossoming principle, if subjected to a series of experiments. This plant, it is well known, does not form a blossom bud, under the usual modes of cultivation, until the cold nights of autumn commence. Yet after the bud is once formed, a gentle warmth of from  $58^{\circ}$  to  $65^{\circ}$  seems very desirable to get the blossoms to expand freely. Now, what we call unequal, irregular, or inclement, seasons tend to produce the blossoming principle in no small degree in many plants ; especially periods of extreme drought, or sudden declension of atmospheric heat after a hot period, together with perhaps an increased degree of solar light. The "buttoning" of the cauliflower has plagued many a gardener : and here, the plant having been imprudently planted too early, and in too rich a soil, is kept through the winter in the close atmosphere of a frame, from which it is transferred in a gouty or plethoric state, and what we gardeners term "drawn," to the open ground, to face a March wind and sun ; the consequence, of course, is, that the growing principle is suddenly arrested, and the premature formation of a blossom is produced. A humid and shady atmosphere like that of Britain, as compared with our more favoured neighbours with their bright skies and perhaps elevated tracts of country, may well be expected to produce cases similar to "drawing." Observe the potato growing in close and rich gardens, and mark the same kind in fresh maiden unmanured soils, in elevated tracts of farming lands ; who would believe it to be the same kind, unless practically acquainted with these facts ?

*Oulton Park, near Tarporley, Cheshire,*  
November, 1841.

## REVIEWS.

ART. I. *Vegetable Physiology ; being Part of a Popular Cyclopædia of Natural Science.* London, 8vo. 1841.

WE noticed this work in p. 327., and the following is a more detailed account of it by our correspondent J. M., of whose extensive knowledge of the subject most of our readers are aware.

"As a means of intellectual discipline, as stated in the Prospectus, the study of natural science is perhaps second to none ; it has the advantage of interesting the pupil much more than the greater part of the ordinary routine



of instruction, and will tend to increase his desire for the attainment of valuable knowledge of any description. No works at present before the public appear to be altogether suitable to this purpose, the greater number of strictly elementary treatises on natural science being little else than abridgements of larger works, so that they are much behind the present state of science, and are for the most part but inaccurate copies of one another, executed in a mechanical spirit, and destitute of the striking novelties which scientific research is constantly bringing into view."

To avoid this defect in the present undertaking, the publishers have employed a compiler of very high talent to bring forth a series of distinct treatises on the different branches of natural science, and which they trust will be found worthy of the patronage of the general reader, and particularly of the young, who may be desirous of acquiring a competent knowledge of those useful and delightful studies.

The authorities whence the compiler has drawn the facts and representations on which he founds his own opinions and statements, and which he recommends as corroborative of his own views, are Lindley, Henslow, Carpenter, DeCandolle and Professor Meyen: relative to the food of plants, he follows Liebig and Lindley. The author, however, is by no means a servile follower: the manner in which he applies the doctrines of the above authors is not without a good deal of creditable discrimination, for where he finds assertions unaccompanied with proof he does not fail, by praiseworthy candour, to show that he is treading on questionable ground.

He commences his descriptions of vegetable phenomena at the lowest point, namely, with an account of what is called the *red snow* of the arctic regions, one of the most minute and simple productions of the vegetable kingdom. Thence he ascends through the various grades of microscopic and cryptogamic vegetation, showing the manner of their reproduction and growth with the clearest and most satisfactory precision, obtainable only from direct ocular demonstration. With the same precision he describes the mosses, liverworts, lichens, *Algæ*, *Fungi*, &c.; all of which is highly interesting, especially as his descriptions are enriched by many valuable collateral remarks and observations.

Among the many fruits of his industry and judgement evinced in the selections he has made from other writers, it would be strange indeed if he did not convey a little of the dross along with the pure metal of some of his authorities. For instance, he says that roots are destitute of buds, which is by no means generally the case. The longitudinal partitions of the wood, commonly called medullary rays, he says are divergent from the pith, whereas they are convergent to that member, as if they proceeded from the bark. The manner of the annual enlargement of an exogenous stem is, however, beautifully and faithfully described; and it is not till he comes to explain how the cambium is changed into wood, that he begins to falter in his statements by adopting the opinions of others rather than his own. "At the *end* of spring," he says, "the bark becomes loosened from the wood, and a glutinous fluid, termed the cambium, is found between them. This is gradually organised into cells, and from these are formed the ducts and cellular portion of the woody layer and of the cellular portion of the layer of bark. Later in the year, the woody tubes grow downwards from the leaves, obtaining nourishment from the fluid portion of the cambium as they descend, and at last partly uniting themselves with the vessels, &c., of the new woody layer, and in smaller proportion with the tissue of the bark."

Now, the above passage should have been rendered thus:—At the *beginning* of spring the bark is raised from the wood by the swelling cambium; which, in the course of the summer, is matured into the various parts of cells, woody fibre, tubes, &c., of which it *rudimentally* consists, ultimately forming the new layers of wood and liber. During its change from the glutinous to the mature state, it, together with the recently formed layers of alburnum and liber, constitutes the chief ducts for the ascending sap, from which it is

distributed to every tissue to which it has access, as well as to the leaves ; which last, from their perspiring functions, attract a very large share, and cause special ducts to be formed for their supply, which ducts are ascending, not descending, tubes. For, if we can conceive that any fibrous or tubular constituents of the stem have a downward rather than an upward development, we reverse the very principle of aerial growth, and deny the result of every experiment which has been made to ascertain such processes of vegetable accretion. Our anonymous author, indeed, is too complaisant in adopting the opinions of those who fancy they can see buds, leaves, and even grafts, "sending down" vessels or fibres into the stem on which they grow, or into the stock on which they are placed. He guards himself, however, in a general way, against giving full credence to descriptions of whatever is said to take place in the interior of a stem, movements which never have been, nor possibly can be, seen ; and yet he is sometimes misled by such representations. As one instance, his 140th paragraph may be transcribed, viz. "It is in the vessels and woody tubes of the alburnum that the fluid absorbed by the roots is transmitted to the opposite extremity of the stem, and these vessels communicate with those of the leaves, which receive it from them. In the liber, on the other hand, the fluid which has been converted in the leaves into nutritious sap descends again through the trunk for the purpose of nourishing its different parts. Of this descending sap a part is carried inwards by the medullary rays, which thus diffuse it through the whole stem, as also through the substance of the roots, down which it is conveyed by their bark. In this descent it mixes with the ascending current, especially at its lower part ; and, being much superior in density, it adds to the density of that fluid, and thus maintains the condition requisite for *endosmose*" (that principle by which the watery fluids in the soil are attracted through the spongioles of the roots to mix with the thicker fluids in the stem). "The vessels," he continues, "down which the sap moves in the bark are of the branching character described as peculiar to those which convey the nutritious fluid. They form a complete network, in which the fluid may be *seen to move* in various directions. For this motion *no definite cause can be assigned*. It does not depend on any impulse from above, corresponding to that action of the roots which raises sap in the stem, for there is *no power* in the leaves to give any such force. It has been *supposed* to depend upon the gravity of the fluid, which will cause it to descend simply by its own weight ; but, if that were the case, it would not *ascend*, as it often does, on the bark of the hanging branches of such trees as the weeping ash or willow. It is only one, however, of numerous cases in which a movement of nutritious fluid through channels in the solid parts it supplies takes place without any evident cause."

This is, at least, a very candid admission, because the whole doctrine of the descent of the sap is still far from being clearly established. It has, indeed, been declared by persons of undoubted veracity, that the counter currents of the crude and elaborated sap may be seen in the almost transparent petioles of certain leaves. Thus much we are bound to believe ; but, as our keenest observation carries us no further than the base of the petiole, we can only *imagine* its subsequent distribution, having no means of proving whether it retires by the bark or by the alburnum ; more especially as we know that the richest sap is always found by tapping, *not* at the bottom, but at *the top* of the tree.

Speaking of endogens, particularly palms, he says, truly, that the stems are formed by the persisting bases of the leaves ; but he has been misled by others into a belief that the youngest leaves are formed at the top of the stem, and that the woody bundle which connect them with the system "passes downwards in the softest part of the stem, which is its interior ; but after proceeding for some distance in this manner it turns outward, and interlaces itself with those which were previously formed." Unfortunately for our author's teachers, the very reverse of this is the fact : the fibrous constituents of each leaf or frond originate at different depths in the interior of the stem, whence

they ascend till they gain the air, when they suddenly turn outwards, to allow of nearly horizontal expansion.

Having said so much of the downward motions of the sap and of woody bundles to form both wood and roots, he adds what he considers decisive proof, by instancing the effects of strangulation of a stem or branch of an exogenous tree. A band, he says, "will offer little impediment to the ascent of the sap from the roots, but it will obstruct any descent. In consequence, there will be a deficiency of the leaf-elaborated nourishment to the parts beneath, and a superfluity above the band; so that a protuberance will arise from the stem just at the point where the downward flow of the sap is checked. This protuberance will increase in progress of years, if the tree survives, so as almost to bury the band beneath it; but most commonly the tree is destroyed, ere long, by the insufficient supply of nourishment to the roots." The author also alludes to the well-known effect produced by the constriction of a twining shoot of the honeysuckle around a stem of any exogenous plant, which obstructs, rather than prevents, the descent of the sap, by causing a spiral ridge to be formed above the whole length of the embracing shoot.

Different effects are produced by different descriptions of ligatures: if metal wire be used singly, the swellings on each side are nearly equal, and very soon cover the wire; if a common woollen shred be used, the protuberance is largest on the upper side; and if a plurality of bands of common twine be tightly tied on a stem, at short distances from each other, swollen rings will be produced on the spaces between the ties. From all such experiments, it is perfectly evident that the cambium, or living membrane of the tree, is only struggling to get free from the compressive action of the bands, and, of course, forms those protuberances so visible on strangulated or ringed stems. The author avows that "the cambium is gradually organised into cells, and from these are formed the ducts and cellular portion of the woody layer;" and he might have added, with great truth, all the tubes and vessels ever found as belonging to perfect alburnum and liber. The gradual growth of all these components exhibiting exogenous expansion, requiring space laterally, must be deranged by any resisting band or unyielding body applied by art or accident to the exterior.

It is perfectly true that the protuberances above a band are not easily explained, unless we admit that there is a descent of *some constituent* of the system; that is, either organisable sap or fibrous processes from the superior parts, either leaves or buds. In seeking information on this point, by cutting into those protuberances, we find neither accumulations of proper or elaborated juice, nor any unusual assemblage of contorted fibres, as we might be led to expect. The interior of these swellings is of similar character to the other parts of the living cambium, and remains of the same alburnous texture after the growth ceases in the autumn; only with this difference, the cellular parts are more extended laterally, which, indeed, is the cause of the protuberance.

The descent of the sap is a very old idea; not only the elaborated sap, as stated by our author and others, but the whole body of the juices of the tree, which, it was supposed, retreated to the roots in winter. This doctrine, I believe, was held by Buffon, and it was confirmed by the experiments of the late Mr. T. A. Knight, who could not otherwise account for the swelling above a ligature. The notion, that woody fibres or actual roots descended from the buds or foliage, was first suggested by Darwin, and afterwards by Du Petit Thouars, and is now adopted by most modern professional botanists and a great majority of gardeners, though positively denied by the late Mr. Knight, who, in speaking of a grafted tree, declared (what is well known to be a fact) that not a particle of the graft ever descended below the place of junction with the stock. Practical gardeners, however, are rarely guided by the physiologist's notions relative to the functions of the leaves, the buds, or superior parts of the tree, as sources of elaborated sap, or as productive of alburnous matter, trusting more to the agency of the roots than to that of the foliage. This is particularly evident in their management of the grape-

vine, and several other fruit-bearing plants. Instead of preserving all these elaborating organs, they divest the tree of the greater number, not only the laterals, but also the points of the fruit-bearing shoots, lest the fruit should be impoverished, and the wood intended to bear the next year's crop diminished, and rendered less fertile. Melon plants are raised and managed so as to produce *one* large fruit, and when this fairly set on a branch, all the other branches are pruned off, and that bearing the fruit is not only stopped, but is deprived of most of its leaves. Larger fruit are obtained from several other plants by relieving them of their summer shoots. This dismemberment of a plant, by robbing it of the organs by which *it is said* to be chiefly fed, is directly contrary to the opinions of the generality of modern physiologists; and, though their ideas respecting the functions of the leaves are peculiarly applicable to herbaceous plants in general, there are many exceptions relative to them, as well as among shrubs and trees, some of the latter presenting the anomaly, that the more they are pruned the more vigorous they grow.

These practical facts are mentioned to show that, with regard to the grapevine, currant, gooseberry, melon, &c., cultivated for their fruit rather than for their bulk of stem or branches, there does not appear to be any absolute necessity for a *downward flow* of either vascular processes or of elaborated sap; for, notwithstanding the manager divests the plant of a great portion of its food-supplying members, he is not disappointed in his main object; and therefore concludes that a very moderate supply (granting that there is any such supply) answers his purpose as well, if not better, than if the plant had been left entire, and in fullest expansion.

It is a pity, perhaps, that our author did not exercise a little more of his own judgement in these particulars, and had not followed those writers whom he has chosen as his guides so closely. For it is impossible that a person of his philosophical turn of mind could examine what has been written concerning the ascent and descent of the sap, the production of woody fibres or vessels from the leaves, and the various and contrary forces or attractions which such phenomena must require, without feeling the difficulty of even conceiving how such circumstances can take place. It is a part of his subject which would have been well worth his closest investigation, before he had been called on to have furnished the present volume.

Respecting the ascent of the sap, our author embraces the idea of Dutrochet, that it is inducted by endosmose, and that the roots are capable of taking up coloured fluids. He adopts Professor De Candolle's belief respecting the excretory powers of vegetables, as well as his system of physiology in general, and likewise his morphology. This agreement with the botanical leaders of the day will gain popularity for the work; but it is evident that, if he had had more practical knowledge of the subject, and had used his own, instead of the eyes, or rather the conceptions, of others, he would have composed a more respectable book: and yet, notwithstanding, it is an entertaining and well written volume, and creditable to the author, whoever he may be.—*J. M. Brompton, Oct. 1841.*

---

ART. II. *Catalogue raisonné des Arbres Fruitiers cultivés dans les Pépinières De Jamin (Jean-Laurent), Fleuriste et Pépiniériste, Membre de la Société Royale d'Horticulture de Paris, Rue de Buffon, 19. 4to, pp. 24. Paris, 1838.*

THE following is an extract from the introductory observations:—

“*Soil.*—I observe, first, that fruit trees with stone fruit are less particular with respect to soil than kernel fruits; and the reason that we plant our peach trees in a rich soil is, because we prune them every year, and force them to produce more new branches and larger fruit than they would produce natu-

rally. As a general rule, kernel fruit trees require a deep and substantial soil, while stone fruit succeeds well with a lighter soil, either calcareous or siliceous. However good the surface of the soil we are going to plant may appear, we must always sound it to find out its depth, and the subsoil on which it rests. To grow fruit trees with success, it is essential that the good soil should not be less than 3 ft. thick for kernel fruit, and from 15 in. to 20 in. for stone fruit, whether the soil is naturally of that depth or rendered so by art. The best subsoil is a gravelly one, or sandy, to allow the water to sink into it easily; the worst is a spongy or clayey soil, which prevents the water from penetrating it. In this last case, if the surface of the soil has not a sufficient slope, the lower roots of the trees, soon finding a stagnation of moisture, suffer, become sickly, and finally die.

“When we set about planting, we have in view to place the trees either where there are none, or to put good ones in the place of those that are bad, worn out, or dead. In the first instance, if the soil is naturally good and sufficiently deep, the expense will be trifling; but, in the second case, it is indispensable to remove the old soil in which the trees grew, and to replace it with fresh mould for the new trees.

“There are two ways of opening the soil for the reception of trees: the first, more common than the other, on account of its economy, consists in making a hole for each tree to receive its roots; the second, more expensive, but better, consists in opening a trench the whole length of the row of trees to be planted. I add a few words on these two methods.

“*Holes.*—When the soil is of a good quality, and rests on a good subsoil, it is customary to make square holes, 4 ft. on each of the sides, and 3 ft. deep, to lay the upper strata, which are usually the best soil, on one of the sides of the hole, and the lower strata, which are usually not so good, on the other side. If the holes could be made some months, or long before planting, the soil would be improved by the influence of the atmosphere. On planting, the hole is filled half full of the earth from the upper layers; if some pieces of turf could be procured, and put at the bottom of the hole upside down, the operation would be more perfect. When the good soil is less than 3 ft. thick, and when the subsoil is spongy or clayey, the holes ought not to be made so deep, but wider by a third, and even double the width, that the roots may have greater facility in spreading horizontally, than in descending perpendicularly.

“*Trenches.*—When expense is not regarded in making a plantation, trenches are dug, 6 ft. broad and 3 ft. deep, in the direction of the rows of trees to be planted, throwing the upper earth on one side of the trench, and the lower earth on the other side; and, when planting commences, the upper or best earth is thrown into the bottom of the trench. On digging these holes or trenches, if the soil is found not to be sufficiently good, some of the soil known to be very good must be mixed with it, in sufficient quantity, whether a half, a third, or a fourth part; but, if the soil in the hole or trench is absolutely bad, it must be removed, and replaced by good soil. Two thirds of good arable soil and a third of meadow soil, well mixed, usually form an excellent soil for fruit trees. The cleanings out of ponds and the sweepings of the streets, thoroughly rotted and mixed with a middling soil, renders it fit for fruit trees. Turf, heaped up in large piles, becomes, in time, a very good soil for them also; or the ground may be improved or enriched by manure thoroughly decayed.

“Good authors advise never to open a tufous or clayey subsoil, even when it is 1 ft. or 6 in. below the surface, and yet the worse it is the more it is dug up in the usual routine; but a great evil ensues, which I must warn proprietors of. After a hole has been made, 4 ft. square and 3 ft. deep, in the tufa or clay, filled with good soil, and a tree planted in it, this tree may grow tolerably, or even very well for some years; but it will soon find itself cramped, as if in a box: its roots, not being able to spread in search of new nourishment, suffer, and the tree becomes sickly.

“When a bad subsoil is found near the surface of the earth, instead of breaking it up, we must, on the contrary, cover it with a thicker layer of good mould, in order that the roots of the trees may not reach it; plant near the surface; and cover the roots properly with an addition of good soil, which is to be spread out so as to slope gradually for two or three yards round the tree. The same method may be pursued if the bottom of the soil is watery or rotten, unless it is considered preferable to drain it by stones or furrows.

“A light and at the same time a substantial soil is the best for fruit trees: when too stiff, it is improved by a mixture of sandy soil; and a sandy soil is improved by mixing it with a stiff one. Cow-dung is suitable for light soils, and horse and sheep dung for strong soils.

“*Planting.*—The first thing to be done in planting is to see that the bottom of the whole contains at least from 12 in. to 15 in. of good soil, well broken, on which the roots may be placed with confidence. This being ascertained, the next thing is to dress the roots of the tree; that is to say, the tips of the roots are trimmed, and any injured ones cut off: the less the healthy roots are cut, the better the operation has been performed. A man then takes the tree, puts it in the place it is intended to occupy, spreads its roots as horizontally as possible on the mould previously thrown into the hole, and holds it in an upright position, while another man, provided with a spade or a shovel, throws earth well broken, and of good quality, on the roots and in the interstices. When sufficient earth has been put to enable the tree to stand perpendicularly, you take hold of it with both hands near the bottom of the stem, and shake it to allow the fine mould to penetrate between its roots, and to bring the graft on a level with the soil; the mould is slightly pressed, the hole is then entirely filled up, and a small concavity or basin is formed round the tree, to expose the graft, and for the convenience of watering the tree if required. The graft may be 1 or 2 inches below the level of the soil in a dry or light soil, while it ought to be from 1 in. to 3 in. above it in a strong or damp soil.

“Planting being completed, it is of great advantage to put litter at the root of each tree, that is to say, to cover the earth round their roots, to the depth of 1 or 2 inches with short dung, leaves, or dried plants; it preserves moisture, and prevents the evaporation from watering, if that should be found to be necessary.

“*Time of Planting.*—Planting may be carried on from November to April, when not prevented by frost or heavy rains; the rule is, to plant early in dry and light soils, and as late as possible in strong, cold, and damp ones. After late planting, it is more particularly necessary to pour a watering-potful or two at the root of each tree, and cover it with litter.

“If a package of trees is received in a severe frost, it must not be undone, but laid in some sheltered place where it does not freeze, and not unpacked till the weather becomes mild. When, at the time of planting, in March or April, the roots of a tree that has come from a distance appear somewhat dry, they must be soaked in a pail or tub of water for an hour or two, and planted before they are dry again.

“*First Cares necessary for a newly planted Tree.*—In planting, it is determined beforehand whether the tree is to have a stem bearing a head freely exposed to the air, in this case a tree has been selected that was trained for the purpose; or a tree is required to be in the form of a pyramid or distaff, the nurseryman supplies trees having a tendency to this form also; or a dwarf tree is wanted to be trained as a bush or a fan. Here follow a few words on each form.

“*A tall-stemmed Tree (l'Arbre tige).*—It often happens that, in planting a tree with a tall stem, the head is cut at the same time that the roots are dressed, that it may not be liable to be shaken afterwards; it also sometimes happens that reasons prevent this operation taking place till the flowing of the sap. However this may be, the operation consists in leaving on the head of the tree three, or rarely four, of the finest and best situated branches to form the members of the new head, in cutting them at a good bud, at the

length of from 3 in. to 6 in. and cutting off all the rest. If what is called a trained tree (*arbre formé*) is wanted, the planting and first pruning would require details which I cannot enter into in this brief notice.

“*The Distaff Form (la Quenouille)*.—It must be owned, that few distaffs are well trained; in most nurseries they are made to grow tall too quickly, and their base becomes bare. There is a certain method of forcing them to feather again at any age, but the explanation would be too long. I must confine myself to informing proprietors, that, when a distaff is bare at the base, the shaft (*flèche*) must be cut very short, the strong upper branches cut off, and the lower ones pruned at an under bud (*sous-œil*).

“*The Dwarf Tree*.—It is usually trees that have been grafted for one or two years near the ground, and which are cut down to 6 or 8 inches from the graft, that are formed into dwarf trees, either as a bush or espalier. In the first case, when the lateral buds are developed, the three or four best situated are selected, and the others removed; in the second case, those are removed that are developed before and behind, and only one or two are retained on each side to form the limbs of the espalier; but, for a pear tree to be trained as an espalier, it is much better to take *quenouilles* that have been grafted two or three years, and in a vigorous state, which gives an advantage of at least two years over dwarf trees.

“There is another excellent form that may be given to an espalier, namely, the fan (*palmette*). It is easily formed with a good *quenouille*, well provided with lateral branches, those behind and before being cut away; if it is not well clothed, it is cut down to 1 or 2 feet, and, by judicious pruning, it is made to throw out branches at the sides.

“*The Apple Tree as a Quenouille, grafted on a Paradise Stock*.—This shape is very little in use; the sap having more branches to nourish than in those forming a bush, prevents the fruit from becoming so large, but the tree produces more: besides, its pyramidal form is more agreeable.

“These trees require to be grown from the strongest and best situated branch, which must be shortened down to a good bud, 6 or 8 inches above the graft. Every year the lateral branches should be cut very short, as well as the stem. Apple trees may be raised on paradise stocks, in the form of a pyramid of from 4 ft. to 6 ft. in height, in a good soil, and well trained by judicious pruning.

“Currant trees may also be trained in this form; they have a very good effect, and produce much more fruit than when grown as bushes.

“I think it essential to notice a false operation too much in use with kernel fruit trees, which, according to the usual routine, takes place in the months of August and September. It is that of shortening the shoots or branches two thirds, or often three quarters of their length. This practice is injurious to the trees, inasmuch as it destroys a great quantity of leaves capable of digesting the food of the plant, and strengthening the roots; this pruning, also, forces the sap into the fruit branches, and changes their destination by making them throw out wood instead of fruit.

“It is the interest of the proprietor, therefore, to prevent this being done, which is absolutely detrimental to their trees; but I recommend the practice of disbudding (*Pébourgeonnage en vert*), which is usually performed in the spring, in the course of the month of May; however, as it frequently happens that the gardener at this period is overwhelmed with work, and cannot do every thing himself, pruning does not take place at this season, which is a disadvantage to the fructification, the shape, and preservation of the trees; it is the interest of proprietors, therefore, to provide assistants to their gardener, that he may have time himself to perform the operation of disbudding. This operation is the more necessary, as it avoids wounds, and lessens the labour of pruning.

“I confine myself to these observations, in order not to exceed the limits I had proposed; and, for further details, I refer my readers to the excellent work of M. Dalbret, *Cours théorique et pratique de la Taille des Arbres Fruitiers*, 1841.—XII. 3d Ser.

2me ed., 1837; in which will be found all the required information, and the best principles, illustrated by numerous examples."

ART. III. *Catalogue of Works on Gardening, Agriculture, Botany, Rural Architecture, &c., lately published, with some Account of those considered the more interesting.*

COMPANION to Goldsmith's *Animated Nature*. Illustrated by several Hundred Engravings on Wood and Steel. A History of the Vegetable Kingdom; embracing the Physiology, Classification, and Culture of Plants, with their various Uses to Man and the lower Animals; and their Application in the Arts, Manufactures, and Domestic Economy. By William Rhind, Member of the Royal College of Surgeons; of the Royal Medical Society, Edinburgh; Author of "Elements of Geology," "A Catechism of Botany," &c. Parts IV., V., and VI. Royal 8vo. London and Glasgow, 1841. 2s. each.

We noticed Parts I. to III. in p. 228., and those now before us justify the favourable opinion which we have expressed of the work.

*The Phytologist, a Botanical Journal*; in monthly numbers; 8vo. 6d. each. Nos. I. and II. for June and July.

This periodical will be received with delight by the botanist, more especially when we mention that its editor is the amiable, intelligent, and enthusiastic author of the *History of British Ferns*, Mr. Edward Newman.

*The Eastern Arboretum; or Rural Register of all the remarkable Trees, Seats, Gardens, &c. in the County of Norfolk.* By James Grigor. Illustrated by drawings of trees etched on copper. Numbers XIII. to XV. 8vo. London and Norwich.

The numbers before us complete the work, which is full of entertainment and instruction to every reader fond of trees, and more particularly to those who are acquainted with the county, the gardens and trees of which Mr. Grigor describes.

*A History of British Forest Trees.* By Prideaux John Selby, F.R.S.E., F.L.S., &c. Illustrated by a woodcut of each species, and numerous vignettes. 8vo, pp. 48. London, 1841.

This is a very beautifully got up work. No pains have been spared on either the engravings or the letterpress, but we must say that the result, as far as respects the engravings, is not at all in proportion to the labour incurred. The portraits of the trees want character, which, we suppose, cannot be attained on so small a scale. Even on the larger scale adopted in our *Arboretum Britannicum*, we found it extremely difficult to get artists to produce character, more especially in the young trees; for it may with truth be stated, that the art of engraving trees, either on copper or on wood, is yet in its infancy. The letterpress is every thing that could be wished; and the work, taken as a whole, may be characterised as one of great beauty, and a fit companion to Yarrel's *British Birds* and Yarrel's *British Fishes*.

*Die Coniferen.* By Francis Antoine. Parts II. and III. 1840.

Part I. of this work is recorded and quoted from in p. 28. The numbers before us carry on the list as far as No. 36., *Pinus canariensis*. The plates are well executed, both in regard to engraving and colouring; and the work, which may be obtained through Mr. Pamplin, will be highly acceptable to many British collectors of Coniferæ.

*A Descriptive Catalogue of Roses grown for Sale by H. Lane and Son, Great Berkhamstead, Herts, for the Autumn of 1841 and Spring of 1842.*

A very copious catalogue of, 1. Roses, which bloom in May, June, and July;



2. Climbing roses, blooming in June, July, and August; and 3. Perpetual, or autumnal, roses, which blow from June till November; occupying only twenty-four pages. It may be sent by post for twopence.

*A Manual of the British Algæ; containing Generic and Specific Descriptions of all the known British Species of Sea-weeds, and of Confervæ, both Marine and Freshwater.* By the Honourable William Henry Harvey. 8vo, pp. 216. London, 1841.

The introduction to this work, occupying 57 pages, is one of the most instructive and agreeable dissertations on botanical classification that we have ever read, and can hardly fail to interest persons in the study of *Algæ* who had previously paid but little attention to these vegetables. We regret that our limits do not admit of our quoting from it.

*A Catalogue of Plants collected in the Neighbourhood of Banbury.* By George Gulliver, F.R.S., F.L.S., Assistant Surgeon to the Royal Regiment of Horse Guards. 12mo, pp. 37. London, Cambridge, and Banbury, 1841.

The arrangement is according to the Linnæan system, and we regret to say that there is nothing added to the names and the habitats to create an interest in the plants. Should the work come to a second edition, we recommend the author to take a hint from the *Flora of Berwick upon Tweed*.

*A few Hints on Root-Pruning of Pear and other Trees, with a Descriptive Catalogue of Fruits.* By T. Rivers, Jun., of Sawbridgeworth.

The catalogue of fruits we have noticed at length, and favourably, in our preceding volume, p. 263. The *Hints on Root-Pruning* are excellent, and may be applied to shrubs and ornamental trees, which it is desired to throw into flower, as well as to fruit trees. The practice is of great antiquity; but it was revived by the late Mr. Beattie of Scone, about thirty years ago, and its great importance has recently been ably shown by Mr. Errington in this Magazine, and Mr. Rivers in the *Hort. Trans.*, and in the present pamphlet.

*The Kitchen-Garden; extracted, by permission, from The British Almanac of the Society for the Diffusion of Useful Knowledge for the Year 1837.* 12mo, pp. 30. London, 1841.

Cheap enough, but too concise to be of much use as a separate work.

*The Farmer's Encyclopædia, and Dictionary of Rural Affairs.* Illustrated by Wood-Engravings of the best and most improved Agricultural Implements, &c. Forming one of the Series of Encyclopædias and Dictionaries now in course of Publication. By Cuthbert W. Johnson, Esq., Barrister at Law; Corresponding Member of the Maryland Horticultural Society; Author of several of the Prize Essays of the Royal Agricultural Society of England, and other Agricultural Works; Editor of the "Farmer's Almanack," &c. Parts I. and II. for September and October. 8vo, pp. 128. London, 1841.

This promises to be a very useful work. The history of agriculture is good; but, in our opinion, there is rather too much said on common plants and weeds. After every botanic name which forms the heading of an article, the natural order ought to have been given, as telling more to any person that has even the slightest degree of knowledge of plants according to that system than a page of words.

*The Journal of the Royal Agricultural Society of England.* Vol. II. Part II. London, 1841.

This excellent journal maintains its high character (see p. 79.) for science and practical usefulness. The first article, on the past and present state of agriculture in Northumberland, is very interesting, as showing the great progress which has been made in agriculture and general civilisation in that county since the middle of the last century, when "the king's writ could not run

throughout the county." There is an excellent article, by Mr. Curtis, on the different insects affecting the turnip crop; and one, by Professor Henslow, on the *Fungi* producing rust and mildew. Besides these articles, which interest the gardener as well as the farmer, there is a copious review of Professor Daubeny's lecture on manures. The purely agricultural papers are numerous and varied.

*The British Farmer's Magazine for 1841.* In monthly numbers. 8vo. 3s. each.

There are many excellent papers in this work, which is very greatly improved since it came under the management of the present editor. Many of the articles are as interesting to the gardener as to the farmer, particularly the papers on vegetable physiology, draining, and the editor's tours.

*The Entomologist.* Conducted by Edward Newman, F.L.S., Z.S., &c.; many years Editor of "The Entomological Magazine;" Author of "Sphinx vespiformis," "The Grammar of Entomology," "History of British Ferns," &c. No. IX. for July. In monthly numbers. London, 1841. 6s. each.

A periodical which will be as acceptable to the entomologist, as the *Phytologist*, edited by the same author, is to the lover of plants. We sincerely wish both journals that success which they so well deserve.

*Brande's Dictionary of Science, Literature, and Art, &c.* Parts II. to VIII.

We have strongly commended this work in p. 177., and the numbers now before us justify our again recommending it to our readers, as the best substitute for a scientific encyclopædia extant in the English language.

*Lectures on Chemistry, including its Application in the Arts.* By Henry M. Noad, Lecturer on Chemistry; Author of Lectures on Electricity, &c. In 8vo numbers. London and Dublin, 1841. 1s. each.

We fear this work is rather too dear to obtain an extensive circulation.

*The Eighth Annual Report of the Royal Cornwall Polytechnic Society.* 8vo, pp. 100; with a woodcut. Falmouth, 1840.

We have noticed the *Seventh Annual Report* of this Society in p. 177.: that before us contains various interesting papers, including three meteorological registers for 1840, with remarks on the weather of that year. The articles are illustrated by five lithographic prints.

*Model Mapping, as suggestive of a general and economic System of Drainage and Irrigation, &c.* By J. Bailey Denton, Surveyor, Gray's Inn Square.

Model mapping has been a favourite object of ours since 1805, as will appear by the following extract from the *Farmer's Magazine* for that year.

"We have seen, at Mr. Loudon's, two models of the North Berwick Estate; one showing the present appearance and contents of the estate in general, and the other showing the effect of an intended new place of residence for the proprietor (Sir Hugh Hamilton Dalrymple). In addition to this last model, there is an elegant manuscript volume, illustrated by drawings and sketches, containing Mr. Loudon's ideas of the place, his reasons for proposing the improvements, and practical directions for executing them; accompanied with *working plans*, a large *vertical profile* showing the effect of the whole, and a general estimate of the expense.

"Mr. Loudon, we understand, intends to send duplicates of the above models, plans, &c., to No. 4. Chapel Street, Bedford Row, his lodgings in London; where, or at No. 7. Terrace, Edinburgh, they may be seen and examined by any gentleman who shall take the trouble of calling." (*Farm. Mag.*, vol. vi. p. 127.) In the preceding page of the same volume are enumerated the advantages which it is supposed will attend this mode of imitating estates.

Under these circumstances, it will easily be conceived that we highly approve of Mr. Denton's pamphlet, which we most cordially recommend to all our readers who take an interest in such subjects; and more especially to landed proprietors who wish to have correct and easily understood representations of their estates.

*Description and Use of an improved Levelling Stave.* By J. Sopwith, F. G. S., Land and Mine Surveyor, Member of the Institution of Civil Engineers.

The object of Mr. Sopwith's improvement is to save time, by enabling the surveyor to read off the figures for himself at the very moment of taking the observation, without requiring any aid from the assistant. This will be an important saving of time, as well as an assurance against mistakes arising from ignorance or inattention. For the construction of the stave we must refer to the pamphlet.

*Illustrations and Descriptions of Kilpeck Church, Herefordshire; with an Essay on Ecclesiastical Design.* By G. R. Lewis: author of "A Series of Groups on the People of France and Germany"; of the Illustrations to Dr. Dibdin's "Tour through France and Germany"; "View of the Muscles of the Human Body"; "An Address to the Manufacturers on the subject of Education, as connected with Design, in every department of British Manufacture"; and, preparing for publication, "British Forest Trees." Parts II. and III. Folio, numerous lithographs. London, 1841.

We noticed Part I. of this work in our volume for last year, p. 561. The two parts before us are of intense interest to those who are at all attached to the study of architecture or antiquities. Mr. Lewis thinks he has got the key to the principles of design of the Gothic architects, as far as respects ornament; and, if he is correct, these principles are certainly very curious. For example, the following is a description of the nave of Kilpeck Church:—

"It appears to me, that the designer intended the figures 19 and 2, at the beginning and end of the nave, to represent the Garden of Eden. The nave to be considered the garden, the place of trial to all who enter therein. Obedience or disobedience to God's commands will then be seen, and the rewards and punishments made known for their fulfilment or neglect. The trees of life, and knowledge of good and evil, are there planted and explained to all who seek it lawfully, by entering in at the strait gate, the door and the way of God's word. Figs. 18, 9, 4, and 3, are fowls of the air and beasts of the field, and 5 is fruit of the trees of the garden; 16 and 17 are Adam and Eve; 15 the serpent, the power of which is seen in the union of many. In the space between the end of 14 and 15 a bracket is wanting, and 14 is defaced. The subject on the lost bracket might have been the fall of Adam and Eve; and on that which is defaced, sorrow or thorns and thistles; 12, the voice of the Lord God walking in the garden; 11, Adam and Eve clothed; and 'the Lord God made coats of skin, and clothed them, and sent him forth from the Garden of Eden to till the ground, from whence he was taken.'" (p. 10.)

In this manner, all the ornaments in the interior, and also on the exterior, of the church, are described and spiritualised; and there are, besides, copious extracts from Durandus, illustrative of the same subject. In short, the perusal of the work is calculated to give a new interest to every Gothic church.

*Report of the Select Committee appointed to inquire into the present State of the "National Monuments and Works of Art," &c.* Folio, pp. 6. 1841.

It is highly gratifying to find that additional facilities are every year being given for the admission of the people to their public monuments, and that acts of this kind are not abused by them. The following notice respecting Hampton Court Palace is gratifying:—

“ This building, consisting of twenty-nine rooms, with its collection of paintings, has been generously and liberally thrown open by Her Majesty’s command, without charge or any restriction of numbers, for five days of the week, from ten to four o’clock in the winter, and to six o’clock in the summer, and on Sundays after two o’clock: the number of visitors has also greatly increased, and the propriety of their demeanour has fully warranted this accommodation. It is pleasing also to observe that those attendants who formerly received fees for admittance express as much satisfaction at the change of system as the public do, who paid them formerly, not unfrequently with reluctance and complaint. To the better feeling now produced must be ascribed the absence of any injury to the pictures, such as is mentioned by Mr. Grundy, the keeper of the pictures, to have taken place a short time before the free system was established. The number of visitors to the palace in 1839 was 116,000, and in 1840, 122,339, mostly of the working classes. The admission of the public on Sunday afternoons, sometimes to the number of 3000 persons, and their exemplary conduct in the palace and gardens, is a peculiar and important feature. The state of the apartments, of the turf, and of the unfenced flower-beds in the garden, where such numbers spread about at will, is certainly a strong proof of the good disposition and improved conduct of the crowds which frequent it, and requires no other comment than a reference to the very small establishment of attendants. There is a notice put up in the garden in the following words:—‘ What is intended for public enjoyment the public are expected to protect;’ and your Committee again call the attention of the House to the satisfactory result of placing confidence in the people.”

*The Journey-Book of England.—Derbyshire.* With twenty-three engravings on wood, and an illustrated map of the county. Small 4to, pp. 150. London, 1841.

A useful and entertaining work, very neatly got up, and very cheap.

*A Development of the Principles and Plan on which to establish Self-supporting Home Colonies; as a most secure and profitable Investment for Capital, and an effectual Means permanently to remove the Causes of Ignorance, Poverty, and Crime; and most materially to benefit all Classes of Society, by giving a right Application to the now greatly misdirected Powers of the Human Faculties and of Physical and Moral Science.* By Robert Owen. 4to, pp. 138. London, 1841.

Mr. Owen, we understand, has obtained possession of land in Hampshire, where he is about to give a practical illustration of his doctrines. We hope he will meet with no obstruction, because it is most desirable to see what his system is capable of effecting.

*The Farmer’s Almanack and Calendar for 1842.* By C. W. Johnson, Esq., and William Shaw, Esq. Small 8vo. London.

A very useful book for the farmer, at the moderate price of 1s.

#### ART. IV. *Literary Notice.*

*THE Guide to the Conservatory*, by Richard Bainbridge, Flower-Gardener to the Right Honourable Lord Wenlock, Escrick Park, Yorkshire, is preparing for the press, under the patronage of the Right Honourable Lady Wenlock, Lady Milner, Mrs. Garforth, &c. &c. Price to subscribers, 6s.; to non-subscribers, 7s.—This work is written expressly as a pocket companion, and is particularly recommended to the young gardener, amateur, &c. Its general feature is brevity with comprehensiveness: at the same time it comprises a practical treatise on a select list of the most choice and admired plants of the

present day; the management of the greenhouse, conservatory, and exotic stove; the Linnæan and Jussieuean arrangements; native country; best mode of flowering, propagation, and soils; the forcing of shrubs, bulbs, &c.; with full instructions for keeping up a succession of bloom throughout every month of the year. Taken from notes of the author's daily practice, and from communications furnished by several eminent floriculturists, &c.

## MISCELLANEOUS INTELLIGENCE.

### ART. I. *General Notices.*

*WHAT constitutes a Gardener.* — He only deserves the name of a gardener who not only knows how to do a thing in his own place, but elsewhere; and why success attends his practice, and how to vary it under new circumstances. Such a man, when he finds winter at midsummer, and the dog-days in December, as in the southern hemisphere, or a climate where our cold season of rest is absent, and in which all the energies of plants are stimulated by heat and rains unknown to him at home, is able to adapt himself to such circumstances, and to shift his times and modes of cultivation, and to change his crops to suit them. In order to acquire this power, he must study with the utmost attention the works of modern writers on vegetable physiology, and make himself master of every thing that is known concerning the way in which plants live, feed, grow, breathe, digest, and have their being. Then combining this knowledge with the manual skill, which it is his business to acquire during the period of his learning the art of horticulture, he becomes a gardener properly so called, and is able to carry on his profession with advantage in whatever climate he may be called upon to exercise it. (*Gard. Chron.*, vol. i. p. 411.)

*Order-Book.*—Mr. Beaton (*Ibid.*, p. 215.) recommends gardeners in extensive places to keep an order-book, which may be done after the manner of a banker's cheque-book, taking a memorandum in the margin before tearing off the order.

*The Theory of Excretions in Plants* is now generally doubted, because the experiments of Macaire, on which it was founded, have, on repetition, given very different results from those which he obtained. The subject is still open to investigation; for as yet we have no unquestionable evidence of any process of excretion, like that assumed by Macaire, &c. (*Ibid.*, p. 630.)

*Effect of coloured Light on Plants.*—Some very interesting experiments on this subject have been made by Dr. Horner of Hull, and Mr. Hunt of the Royal Cornwall Polytechnic Institution. The following extract is from the Report of Mr. Hunt:—

“During the early part of the spring of 1840, some experiments I was then pursuing on the chemical influence of solar light led me to the discovery of some extraordinary facts connected with the action of light on vegetation. With the hope of exciting the attention of those engaged in horticultural pursuits, and of rendering some assistance, little though it be, in overcoming some of the difficulties experienced in causing the germination of the seeds of some rare exotics, I am induced to trespass on the time of the Society. It is scarcely necessary to explain that every beam of light proceeding from its solar source is a bundle of different-coloured rays, to the absorption or reflection of which we owe all that infinite diversity of colour which is one of the greatest charms of creation. These rays have been long known to possess different functions, and have hence been distinguished according to their supposed properties; the violet and blue being called the chemical rays, the green and yellow the luminous rays, and the red the calorific or heat-giving rays. These distinctions

are not in accordance with the strict truth, but they are sufficiently so to suit my present purpose. The light which permeates coloured glasses partakes, to some considerable extent, of the character of the ray which corresponds with the glass in colour: thus, blue glass admits the blue or chemical rays, to the exclusion, or nearly so, of all the others; yellow glass admits only the permeation of the luminous rays, while red glass cuts off all but the heating rays, which pass it freely. This affords us a very easy method of growing plants under the influence of any particular light which may be desired. The fact to which I would particularly call attention is, that the yellow and red rays are destructive to germination, whereas, under the influence of violet, indigo, or blue light, the process is quickened in a most extraordinary manner. The experiment is very readily tried by covering a box in which seeds are sown with coloured glasses. The plants will grow most luxuriantly beneath glass of a blue character, but beneath the yellow and red glasses the natural process is entirely checked. Indeed, it will be found that at any period during the early life of a plant, its growth may be checked by exposing it to the action of red or yellow light. Here we have the very extraordinary fact, that that portion of the sun's light which produces the greatest impression on the organs of sight, and that also which diffuses warmth through the creation, are destructive to the first processes of vegetation. It is with much satisfaction that I find the results to which I have arrived corroborated by Dr. F. R. Horner of Hull. In conclusion, I may be allowed to point out, that by studying the effect of these different rays, isolated and in different states of combination, we have the means of imitating the nature of any clime of which a plant may be the habitant. By blending the violet with the yellow light in certain proportions, we may artificially produce the light which shines on 'Syria's land of roses;' by uniting with these the red light, we may produce effects on our island soil similar to those seen on the arid wilds over which 'the acacia waves her yellow hair;' and by isolating the violet rays we may, to some extent, imitate the climate of the frigid zone." (*Gardener's Chronicle*, vol. i. p. 347.)

*Charcoal Dust* spread over soil would appear to deter insects from laying their eggs there, and hence it is recommended as a preventive of the onion grub, and of clubbing in cabbages. (*Ibid.*, vol. i. p. 165.)

*Sawdust mixed with Stable Manure*, in forming hotbeds, causes them to keep longer in heat than when made altogether of stable manure. (*Ibid.*, p. 149.)

*Pounded Brick-bats* are recommended as a substitute for crocks; a flat crock being placed over the whole, and some rough peat on the top of the brick drainage. (*Ibid.*, p. 229.)

*The Guernsey Weeding-Prong*.—The head of this implement (*fig. 58.*) is in the shape of a claw-hammer, with the one end flattened into a chisel, 1 in.

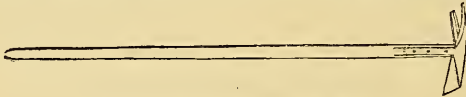

Fig. 58. *The Guernsey Weeding-Prong.*

wide; and the forked, or clawed end, consisting of two sharp flat prongs, by which the weeds are grubbed up and lifted at the same time. The length of the head, from the extremity of the chisel end to that of the prong end, is 9 in., and it is attached to a handle 5 ft. long. A great part of the labour of weeding may, in most gardens, be performed by women and children; and it will not only be lightened, but their hands will be kept clean, by the adoption of the Guernsey prong. (*Ibid.*, p. 66.; and *Sub. Hort.*, p. 238.)

*Sending home Seed from Foreign Countries*.—To emigrants and others sending seeds from foreign countries, Dr. Lindley recommends strict observance of the following rules:—“1. Let the seeds be *thoroughly dried* by exposure to the sun (not a fire), or in a dry chamber; this is of the first importance. 2. Let the papers, also, or canvass bags, in which they are

packed, be thoroughly dried. 3. Let the smaller packages be tied up separately, and then placed loosely in canvass bags, or coarse sacking, so that they can be readily disturbed by shaking up during a voyage. 4. Let arrangements be made for these bags being kept in a dry cabin, or some well-ventilated part of the ship." (p. 715.)—To which we may add, on the authority of Mr. James Backhouse, that suspension 2 or 3 feet from the ceiling of the cabin is desirable, in order to avoid the heated moist air that rises from the floor to the roof, and rots articles there which are found quite fresh midway down.

The Hon. W. Leslie Melville, who brought home the cones of the deodar cedar, from the seeds contained in which so many plants have been raised, kept the cones in his cabin in a box not sealed or soldered up, and occasionally exposed them to the sun and air during the voyage of four months, and did not allow them to encounter the heat of the hold of the ship. (*Gard. Chron.*, p. 731.) As exceptions to the general and important rule of ventilating seeds as a means of preservation, Dr. Lindley adds the following:— "If acorns or sweet chestnuts are preserved dry, they soon lose their vitality; the same is apparently true of the mango, of magnolias, the Chilian araucaria, and some other plants. The reason of this has never been satisfactorily explained. It is, however, known that the most certain mode of conveying these seeds is to place them in a situation where they are unable either to absorb moisture or to lose it. The best manner of effecting this, is to pack them in dry sand, or nearly dry loam. Take a box of wood sufficiently stout to resist some pressure from within; strew 3 in. of sand on the bottom; upon this place a thin layer of the seed, taking care that the outside seeds are not nearer than 3 in. to the side of the box; then cover this layer with  $1\frac{1}{2}$  or 2 inches of sand, according to the size of the seeds, and go on placing the seed and sand in alternate layers, till the box is full; place 3 in. more sand on the upper layer of seed, and fasten down the lid. With these precautions, all the seeds mentioned, and others of a similar kind, will travel for some months without injury. It is, however, necessary to observe that the sand or earth must be pressed down very firmly, so that it may not be able to settle away from the sides of the box after the lid is fastened down. This is also the best way to pack bulbs for a long voyage, provided they are ripe when they are collected."— (*Ibid.*, p. 731.)

*The Oxygenation of Water by green Plants and Animalcules.*— Professor A. Morren of Angers, and Professor C. Morren of Liege, have communicated to the Royal Academy of Sciences at Brussels an important memoir on some properties in water hitherto unknown, which, it is said, will have considerable effect upon the watering of plants, and on public health. Humboldt and Gay Lussac ascertained experimentally that the running water of rivers, and distilled, and aerated water, contain a bulk of air equal to one fourth of their own volume dissolved in it, and which consists of oxygen and azote, in the proportion of 32 of the former to 68 of the latter. Messrs. Morren have proved that this air in the water may contain from 56 to 98 parts of oxygen, when it is stagnant, or when it has green vegetables (*Confervæ*) and green animalcules in it. In July, in the morning, 100 parts of water hold in solution 25 parts of oxygen, 48 at mid-day, and 61 at 5 o'clock in the evening. The quantity of nitrogen always remains the same. The influence of light on the respiration of plants and animalcules determines the oxygenation of water. In days when there is little or no sun, water contains little oxygen, and is less wholesome. In rainy days no oxygenation goes on. The oxygenation commences at daybreak, and arrives at its maximum at 5 in the afternoon, at which time water is much more salubrious than at any other hour for watering plants, since it supplies their roots with the greatest amount of oxygen. (*Ibid.*, p. 199.)

*Suspended Vegetation.*— M. Pepin gives a number of curious examples, including fragments of roots of the following species which had remained buried and torpid:— *Bignônia radicans*, for 10 years; *Gymnócladus canadensis*, 10;

locust trees, 10 ; *Ulmus campestris*, 6 ; *Dodartia orientalis*, 8 ; *Euphorbia*, 6 ; *Hoffmannsëggia falcata*, 10 ; *Solanum carolinianum*, 10 ; *Pulmonaria virginea*, 5 ; *Urtica cannabina*, 4. (*Gard. Chron.*, vol. i. p. 716.)

*Raising Plants from Seed.*—Mr. Gordon of the Hort. Soc. Garden states that all seeds from North America and California should be sown in the autumn, as soon as ripe ; to defer sowing them till the spring may in all cases be disadvantageous, except in the case of annuals: that Mexican and Chilian seeds succeed best if sown in spring: that, with regard to Europe and the North of India, trees and shrubs should be sown in the autumn, and annuals or perennials in the spring: that all seeds, of whatever kind, should be sown in dry soil, and not watered till they begin to vegetate ; in the case of old or sickly seeds, to water them at the time of sowing is to insure their destruction by rotting: that shading is to be preferred to watering ; and that one of the best constructions for the purpose, is a pit glazed with double sashes, like one in the Society's garden: finally, that all seedlings should be potted or transplanted as soon as possible, except bulbs. (*George Gordon, ibid.*, p. 438.)

*Root-Pruning* is founded on the principle that, "if the roots of a plant are large and numerous, the head must be so too ; for this plain reason, that the amount of fluid food received by a plant is in proportion to the size and extent of its roots, and that food must be expended in the formation of branches ;" and that "whatever produces excessive vigour in plants is favourable to the formation of leaf-buds, and unfavourable to the production of flower-buds ; while, on the other hand, such circumstances as tend to diminish luxuriance, and to check rapid vegetation, without affecting the health of the individual, are more favourable to the production of flower-buds than of leaf-buds." (*Theory of Hort.*, p. 65.) The operation may be performed at any time between the fall of the leaf and the swelling of the buds in spring ; but it is better to execute it before the end of November. (*Gard. Chron.*, vol. i. p. 683.)

*Acclimatising Plants.*—From numerous experiments made upon this subject in the Hort. Soc. Garden, it appears:—1st, That plants which it is intended to acclimatise should never be subjected to artificial heat during the winter that precedes their being planted out ; that if obtained from seeds, as little heat as possible should be employed in raising them ; and that starved or stunted plants are more likely to succeed than such as have been forced into a rapid and luxuriant growth. 2d, That the plants should not be committed to the open ground earlier than the end of May ; that the soil should be poor, dry, and thoroughly drained ; that, if against a wall, the border should be protected through the entire winter by a roof of hurdles thatched with straw, and projecting about 3 ft. A thermometer placed under such a covering did not, during the three months of February, March, or April, stand more than two or three degrees higher than one freely exposed ; from which it appears that it is the dryness of the situation, and not its greater warmth, that renders a border protected by a roof of thatched hurdles so useful to tender plants. (*G. Gordon, in Gard. Chron.*, vol. i. p. 43.)

*Neatness often the Cause of impoverishing the Soil*, more especially in public gardens, where manure is never given. In a forest the leaves fall and decay ; limbs torn off by a storm themselves crumble by degrees ; the fruit drops at the foot of the parent, and all, but that minute portion which grows into another plant, rots and restores to the earth what had been abstracted in its own formation ; and that life is perpetually maintained by the operations of death. In our squares and promenades, on the contrary, not a leaf falls, nor a bough is broken, but is immediately swept away, for the sake of neatness ; and the trees give up all that nature bounteously provides for their renovation, without receiving any thing in return. If we rob plants of one kind of food, because it offends our eyes, we must give them some other to which the same objection does not apply. (*Gard. Chron.*, vol. i. p. 163.)

*The Scion will affect the Quality, although not the Organisation of the Stock.*—Pears grafted on the mountain ash are rendered more vigorous and hardy, and



also earlier. Pears on quinces become more high-coloured; peaches on plum stocks are coarser than on peaches, and much inferior in quality. Apples on the Siberian bitter-sweet are more highly coloured than on the crab. An apricot is said to have been worked on a greengage plum, and a quince upon the autumn bergamot pear; the apricot became as juicy as the greengage, and far more delicate, the quince was much more tender, and less gritty. Now, if the quality of fruit is affected by the stock that bears it, one would infer that the goodness of all our cultivated fruits is deteriorated by their being uniformly worked upon stocks whose fruit is worthless; for example, the almond or the austere plum can only injure the peaches they are made to bear, the crab the apple, and so on. On the other hand, if trees of excellent quality were used for stocks, they ought to improve the fruit of the scion that is worked upon them. We see that some German writers, proceeding upon some such reasoning as this, have been recommending gardeners to practise the art of "ennobling" fruit trees, by taking the best varieties for stocks, instead of the worst, and they assert that, by such means, the excellence of fruit is greatly increased. Trefftz is represented by Meyer, as translated in *Taylor's Magazine*, to have made known, as long ago as 1803, several instances of ennobling; from which it appears that apple trees twice ennobled bore fruit of distinguished excellence, currants and gooseberries improved after one ennobling, and much more so after the operation had been repeated three and four times. The bud of a variegated white jasmine being inserted in the bark of *Jasminum revolutum*, though the eye did not grow, yet as the bark lived and adhered, such was its influence, that the revolute jasmine became variegated. If a taint producing variegation can be thus communicated, why not some other quality, such as taste, flavour, or smell (*Gard. Chron.*, vol. i. p. 307.)

*Propagation by Leaves.*—You requested me to state in writing, the success which I had many years ago in raising certain monocotyledonous plants from the leaf. In the year 1809, I first tried to raise bulbs of a Cape ornithogalum, by setting a cutting of a leaf. The leaf was cut off just below the surface of the earth, in an early stage of its growth, before the flower-stalk had begun to rise, and it was set in the earth near the edge of the pot in which the mother plant was growing, and so left to its fate. The leaf continued quite fresh, and, on examination (when the bulb was flowering), a number of young bulbs and radical fibres were found adhering to it. They appeared to have been formed by the return of the sap which had nourished the leaf. Thereupon two or three leaves more were taken off and placed in like situations, but they turned yellow, and died without producing any bulbs. It appeared to me then, and it was confirmed by subsequent experience, that, in order to obtain a satisfactory result, the leaf must be taken off while the plant is advancing in growth. I found it easy thus to multiply some bulbs that did not willingly produce offsets. I afterwards tried, without cutting the leaf off, to make an oblique incision in it under ground, and in some cases just above ground; attempting, in fact, to raise bulbs by layering the leaf. This attempt was also successful; and some young bulbs were formed on the edge of the cut above ground, as well as below. I tried cuttings of the stem of some species of *Lilium*, and obtained bulbs at the axil of the leaf, as well as from the scales of the bulb; and that practice has been since much resorted to by gardeners, though I believe it originated with me. I raised a great number of bulbs of the little plant which has been successively called *Massônia*, *Scilla*, and *Hyacinthus corymbosus*, by setting a pot full of its leaves, and placing a bell-glass over them for a short time. A bulb was obtained with equal facility from a leaf of a rare species of *Eûcomis*; and experiments with the leaves of lachernalias were generally successful. I apprehend that all liliaceous bulbs may be thus propagated; but the more fleshy the leaf, the more easily the object will be attained. (*W. Herbert*, in *Gard. Chron.* for 1841, p. 381.)

*Budding.*—Much depends on the edge of the shield of the bark containing the bud being cut quite smooth. In the act of cutting out the piece of wood with the bud, if there is much to be done, the knife is soon blunted in

the edge, and the bark cuts rough; indeed, even when the knife is newly sharpened, it will always come out rougher than with the following plan, and, besides, the bark is apt to be hurt by extracting the wood after it is cut off the shoot. All these may be prevented, by cutting the bark all round the bud to the exact shape and size wanted, without cutting the wood at all. After this, if the thumb be applied to the side of the bud and gently squeezed upwards, the bud will come out as smooth as glass in the cut, if the bark is free; and, unless it be so, the budding is not like to do well. For cherries, plums, peaches, and fruit trees in general, this is the best of all methods; the piece of wood is apt to fly out between the bud and bark if the bud is well ripened, but it is apt to fly out at any rate by any of the methods; the base of the bud is, however, uninjured, and, if this is left, the wood is easily regenerated. It has been long the general opinion among nurserymen, that the wood is essential; but we have often marked pieces of work done with buds where the wood had come out so hollow at the eye that the base of the bud could not be perceived, and they generally succeeded better than the other buds. (*R. Lymburn, in Gard. Chron., vol. i. p. 533.*)

*Tobacco-Paper* is preferable to tobacco to fumigate with, because it is cheaper, and does not burn so fast. (*Gard. Chron., vol. i. p. 213.*)

*Tobacco-Water* will kill all aphides, but much more effectually when warm than when cold. (*Ibid., p. 617.*)

*Spirit of Tar* mixed with sand, at the rate of a gallon of spirit to a barrow-load of sand, and strewed over sixty or seventy square yards, will deter insects from depositing their eggs there by its powerful smell. (*Ibid., p. 105.*)

*Sulphuretted Hydrogen Gas* is recommended for destroying rats, mice, and other noxious animals, in their lurking-places, and it might also be employed to destroy insects in plant structures. (*Ibid., p. 199.*)

*Stifling Insects by coating them over with Clay Paint*, paste, or gum-water, may sometimes be had recourse to; life being destroyed by preventing respiration. (*Ibid.*)

*Detering Insects by Mud.*—The gooseberry caterpillar may be destroyed by sprinkling the bushes with water, and then dusting them with dry soil, which forms mud on the surface of the leaves. A decoction of the root of white hellebore has also been found effectual; and hellebore in powder still more so. Attention must be had that the powder reaches the caterpillars, whether on the upper or under sides of the leaves. (*Ibid., p. 533.*)

*To destroy Moss in Lawns.*—Moss may be destroyed in lawns by watering with pure gas water, diluted with water in the proportion of one to two; and also with nitrate of soda, at the rate of 1 cwt. per acre. The latter is more effectual, and more productive of grass afterwards. (*Ibid., p. 613.*)

*The Construction of Pipes for circulating hot Water* has been lately much improved by Mr. Perkins, who has introduced screw-joints and couplings of peculiar kinds, which render stuffing and cement wholly unnecessary. The construction is so simple that the pipes may be put up by any gardener, without the aid of a mechanic. (See *Repert. of Arts for October, 1841, p. 218.*)

*Heat considered relatively to Plant Structures.*—In Mr. Ainger's first paper (*Gard. Chron., vol. i. p. 211.*), he endeavours to show "that heat at all temperatures is transferred much more effectually by radiation than by the contact and carrying power of the air. As a proof of this, he mentions the greatly superior radiating power of earthenware, compared with the greater conducting power of metal, as exemplified in an earthenware teapot as compared with a silver one. The distinction between what I have called carrying power and conducting power is very important, and requires to be borne in mind. Gases and liquids have no appreciable conducting power; they receive heat by contact, and the part so heated, ascending by reason of its acquired levity, gives place for a fresh portion to be heated and ascend in its turn. Again, it must be remembered that, even as carriers, gases and liquids take up heat by contact only, and absorb no sensible portion of that which traverses them in a radiant state. The sun's rays may be brought to a focus

which would melt platina, without producing any effect when the concentration takes place in air or water.

The enormous differences produced in the rate of cooling and transmission by change of surface, as shown in Sir John Leslie's and other experiments, prove beyond question that radiation is the great and important channel by which interchanges of heat take place, and that when it is proposed to substitute for this the carrying power of the air, we adopt a feeble, difficult, circuitous mode of effecting a purpose which will accomplish itself rapidly and spontaneously, by placing the objects, so to speak, in sight of each other. There is the further advantage, before alluded to, that by radiant heat we communicate heat only; whereas, by using air, we introduce a new set of conditions in regard to moisture. With radiant heat it may, indeed, be requisite to supply moisture, which, when necessary, is easily done; but with air as the carrier, air, therefore, in constant change, we employ a vehicle whose relations to moisture are extremely difficult to maintain in exactly the proper state. Air, warmed and unsupplied with moisture, is a very sponge, and exerts an unlimited drying influence upon all fluids presented to it; and air, if warmed and fully saturated, becomes a wet sponge, which will deposit moisture on all bodies at an inferior temperature with which it comes in contact. The fact is, that air is a very efficient cooler or warmer, if it be allowed freely to attract moisture in the one case or to deposit it in the other; but as we do not always require to do these, or not, at least, in the proportions which might suit the capacity of the air for absorbing or retaining moisture, it is better, I think, to warm by means which are more independent. (*Gard. Chron.*, vol. i p. 212.)

*Boiler Furnaces.* — Mr. Ainger recommends combustion within slowly-conducting materials, radiation to the largest possible quantity of surface, and avoidance of circuitous flues. (*Ibid.*, p. 684.)

*Laying Hot-water Pipes in Troughs of Water*, as at Mrs. Lawrence's and Mr. Green's, is strongly recommended. (*Ibid.*, p. 597.)

*Glazing Hothouses.* — The exclusion of water and the prevention of breakage depend much on the laps touching in every part, so as to admit no moisture between; such moisture being driven into the house by high winds, and expanding and breaking the glass during frost. (*Ibid.*, p. 646.)

*Old Putty softened.* — Old putty may be softened by rubbing it with soft soap, and allowing it to remain for a few hours. (*Ibid.*, p. 685.) To remove old putty, the glaziers pass a warm iron a few times over it. (*Ibid.*, p. 613.)

*A Pit for wintering Plants* should have the bottom dry, by its being raised 12 or 18 inches above the adjoining surface, besides should be so constructed as to exclude frost, and the aspect should be to the north. If it faces the south, the air within it is apt to become heated by the sun, and thus the plants are stimulated into temporary growth at unpropitious seasons.

The necessity for a winter-house being dry, seems to arise out of the nature of vegetation, which, being entirely passive, cannot resist the influence of surrounding media. If the air or soil is damp, plants exposed to them must absorb that moisture: but, from the lowness of the temperature of a winter-house, their powers of digestion and assimilation are torpid, and therefore the water they receive, instead of becoming incorporated with their system, stagnates in their cells and cavities, where it becomes putrid; and, as soon as this takes place, the evil extends with rapidity, causing both branches and stems to become rotten; for decay in plants is always contagious, and will spread through all the parts with which it is in contact, until the renovated forces of vegetation restore the equilibrium of chemical constituents, and thus arrest contagion." (*Ibid.*, p. 659.)

*A Fruit-Room.* — The principles which ought to guide the designer are, darkness, a low and steady temperature, dryness to a certain point, for apples are found to keep best in a rather damp atmosphere, and exclusion of the external air. If the light of the sun strikes upon a plant, the latter immediately parts with its moisture by perspiration, in proportion to the

force exercised on it by the sun, and independently of temperature. The greatest amount of perspiration takes place beneath the direct rays of the sun, and the smallest in those places to which daylight reaches with most difficulty. Now, the surface of a fruit perspires like that of a leaf, although not to the same amount. When a leaf perspires while growing on a tree, it is immediately supplied with more water from the stem, and thus is enabled to bear the loss produced by light striking on its surface; but when a leaf is plucked it withers, because there is no longer a source of supply for it. So it is with a fruit: while growing on the tree, it is perpetually supplied by the stem with water enough to replace that which is all day long flying off from its surface; but, as soon as it is gathered, that source of supply is removed, and then, if the light strikes it ever so feebly, it loses weight, without being able to replace its loss. It is thus that fruit becomes shriveled and withered prematurely. Light should therefore have no access to a good fruit-room.

Temperature should be low and uniform. If it is high, that is to say, much above  $40^{\circ}$ , the juices of the fruit will have a tendency to decompose, and thus decay will be accelerated; if, on the contrary, it is below  $32^{\circ}$ , decomposition of another kind is produced, in consequence of the chemical action of freezing. In any case, fluctuations of temperature are productive of decay. A steady temperature of  $35^{\circ}$  to  $40^{\circ}$ , with a dry atmosphere, will be found the best for most kinds of fruit. Some pears of the late kinds are, however, better for being kept in a temperature as high as  $60^{\circ}$ , for this ripens them, deprives them of their grittiness, and improves their quality very essentially. We do not, however, conceive that the general construction of the fruit-room ought to be altered on their account; we would rather make some special arrangement for such cases. (*Gard. Chron.*, vol. i. p. 611.)

The air should be kept moderately dry, but ventilation should not be used except for the purpose of removing offensive smells, arising from the putrefaction of the fruit. Ventilation by continual currents of air carries off from fruit the moisture which it contains, and thus acts in the same way as light, in producing shriveling, and destroying that plump appearance which gives its beauty to fruit. Another reason against ventilation is, that an equable temperature is scarcely to be maintained when the air is constantly changed. The sweating of fruit throws so much moisture into the air, that ventilation is necessary to remove it; but the sweating ought always to be carried on in a place provided on purpose.

Great care should be taken in gathering, handling, and storing the fruit, placing each kind by itself, and keeping wall-fruit apart from standard fruit. Gather in baskets, and place the fruit on the shelves side by side with their eyes downwards. When gathering and stowing are completed, shut the room as close as possible, and only open it when fruit is wanted. (*Ibid.*, p. 61.)

*Construction of a Fruit-room.*—To construct a fruit-room agreeably to the foregoing principles, the following directions are given. The situation should be near the gardener's house, and the size sufficient to contain the whole of the winter fruit spread out on shelves, in layers of one fruit in thickness. The walls should be rendered frost-proof, by building them hollow, or covering them externally with a casing of thatch or soil. Windows are not necessary, but, as they are convenient, they should be small, with double sashes and inside shutters, which may be wadded, the more effectually to retain the heat. The ceiling should be rendered frost-proof by a roof of thatch, by pugging with hay, or by having a chamber over it. In this chamber summer fruit can be placed, and winter fruit may be sweated, and throughout the year the dessert prepared; though for this a small room on the ground floor would be found more convenient. The communication from the chamber to the fruit-room might be by a trap-door; and ventilation can be produced, when required, by opening the outer door of the fruit-room, the trap in its ceiling, and the windows of the chamber, when the air is not below  $36^{\circ}$ . In fruit-rooms unprovided with an upper chamber, there must be a few wooden chimneys carried through the roof from the ceiling, where they are to be closed by a flap; and upon opening the latter,

together with the door of the room, a sufficient current of air for ventilation will be produced.

In all cases the room must be built on a dry bottom. If the situation is low, the foundations must be raised in proportion, so as to elevate it completely above the damp of the earth; and if it is floored with "concrete," or some substance impervious to moisture, and in which mice cannot burrow, so much the better. It *must* be dry.

Supposing that space enough can be afforded, the fruit-room would be improved by being divided into two or three compartments, to separate the ripening fruit from that which will be later. In such a case, the door should be at the end of the fruit-room, and the fruit which first ripens should be next the door, while that which is latest should be stored up in the furthest compartment. The reason for such an arrangement is, that the compartment next the door may be ventilated without opening the other divisions; and, as ripening fruit requires more ventilation than such as is still immature, this is an important provision. Then, when the first division is empty, the second can be opened and ventilated without interfering with the third. In such a case, however, where a chamber is over the room, the second and third compartments must have chimneys carried through the floor of the chamber.

In situations where the fruit-room can be built adjoining a hothouse, it would be advantageous to construct an additional closet, which may be warmed by the flue of the hothouse, in order to receive winter pears. These are all exceedingly improved if gradually introduced into a temperature of 60°, or thereabouts, in which to ripen. The chaumontel, in particular, which in common fruit-rooms remains incurably gritty, becomes as melting as the delicious specimens from Jersey. (*Gard. Chron.*, vol. i. p. 643.)

The interior should be fitted up with shelves of open-work of white deal, or some other wood that will not give an unpleasant taste to the fruit. There should be a table on which to place the baskets when the fruit is first brought in, and also for taking it out; and there should be wooden boxes, or earthen jars, in which to pack particular varieties. (*Ibid.*, p. 643.)

*Ventilation of Plant Structures.* — Introducing fresh air into hothouses by means of small pipes in the centre of hot-water pipes, practised by Mr. Weeks, is much approved of. The hot-water pipes are 4 in. in diameter in the inside, and the air-pipes fixed within them are 2 in. in diameter. "This inner pipe is put into the large one in lengths of about 4 ft., each end of which is turned through the large hot-water pipes, one outward and the other inward. The end that is taken outward is passed through the front wall, and the other end into the house; thus the air passes through the small pipe into the house. Now it will be seen that the large 4-inch pipe, which is fixed in the usual way above ground, for the purpose of heating the house, and which is full of hot-water, has an internal pipe for air: the air being introduced from the outside of the wall, has to pass through the body of hot water, and by so doing it gains such a degree of heat that, by placing the ball of the thermometer close to the end of the air-pipe inside the house, it will rise to 160° or 170°; and the circulation of air is so quick, that the leaves of plants are kept in constant motion by a stream of fresh and heated air coming in at every 4 ft. I have paid attention to the manner in which the air is heated and circulated, and am satisfied that the result will be most beneficial." (*John Green*, in *Gard. Chron.*, vol. i. p. 597.)

*Tanner's-Bark Walks.* — Fresh tanner's bark makes a pleasant winter walk, particularly on tenacious soils, as it never adheres to the shoes, either during rain or after frost; half an inch in thickness, I think, is sufficient. It likewise makes a soft and pleasant summer walk, and, from its loose nature, is readily cleared from weeds. If not wanted during summer, it may readily be swept clean off after a few dry days. It is invaluable for covering walks or foot-paths in the kitchen-garden, where there is much wheeling of manure or soil to be done during frost, which is too often obliged to be suspended after ten or eleven o'clock, when there is a clear sunshine, from the ground getting soft

and clammy. With a covering of tan, the operation may be continued throughout the day, and even during wet weather. If the tan remain permanently, it will require renewing every two years. (*D. Cameron, in Gard. Chron., vol. i. p. 101.*)

*Paving Roads with India-Rubber.*—A patent has been taken out for “covering roads, and other ways or surfaces, and also the tops or surfaces of walls usually paved or covered, by the application of India-rubber (caoutchouc) combined into blocks or slabs,” by a stone merchant. It is well known that India-rubber can be reduced to a soft and pasty state by grinding; and it seems that, while in this state, a quantity of charred sawdust is gradually ground in along with the India-rubber. The mass thus formed is next pressed in a mould, into which a quantity of strong rough sand has been put, so that the surface of the block by means of this material may be adapted for resisting the pressure of a road. The sizes of the blocks may be varied, but the patentee considers blocks 12 in. by 12 in. by 3 in. a proper size; for paving footpaths, blocks or slabs of 1 in. are of a convenient thickness; and for covering walls, he makes the blocks about the size of ordinary bricks. In using such blocks for paving, the road or way is to be brought to a proper surface, as if about to be paved with blocks of other materials; and the India-rubber blocks are to be applied over such surfaces, and caused to adhere one to another by using India-rubber cement. We are not aware of the cost of this mode of paving, but we think it might answer for garden walks in some situations where gravel is wanting or bad, or on steep surfaces.

*Propagating Coniferous Plants by Cuttings.*—The following method of striking the different kinds of pines from cuttings has been attended with considerable success. In August or September, select a young shoot of moderate strength, and cut it off with a piece of the last year’s wood attached, forming what is technically termed a heel. The leaves at the bottom of the cutting should not be pulled off, but must either be left on entire, or shortened with a sharp knife. When the cutting is made, it should be planted from a half to three quarters of an inch deep in a pot, filled about one third with potsherds, on which a layer of turfy peat should be placed, then 1 in. of good loam, and on the top of all a layer of white sand. The loam prevents the cuttings from cankering after they are rooted, which they are apt to do when planted entirely in white sand. The pot of cuttings may now be placed in a cold-frame, kept close, and shaded when necessary; they may remain in this situation till the end of October, when they should be put in a cold-pit for the winter; care must be taken at that season that they do not suffer from frost or damp, but they must on no account have fire heat. About the end of February the pot of cuttings may be removed to a hotbed, a bell-glass being placed closely over it; the cuttings will root readily, and many of them will be fit to pot off by the end of June. When first potted off, the young plants should be treated exactly in the same manner as the cuttings are. In the case of junipers and cypresses, older wood than that used for pines is necessary, as they have not sufficient strength to emit roots before the winter, and consequently perish during that season, when only callous. If wood of two or three years’ growth be taken, it will be found hardy enough to stand the winter, and, with the aid of artificial heat in spring, will root freely. (*G. G., in Gard. Chron., vol. i. p. 363.*)

*Stunted Ash Trees.*—Ash trees which are stunted and hide-bound may be rendered fine trees by heading them down. The saw should be applied first above the point where the secondary branches diverge from the principal ones; indeed we may often observe, about this part and lower down, that nature is even giving a kind of hint that she is prepared to second us, for the young shoots which she annually sends forth from the stems of the branches would immediately expand and form a new head. About two thirds of the entire height is often a proper point at which to cut; and in many a large tree most of the branches divided will not exceed the thickness of a man’s arm, so that the wounds, considering they are in the most active part of the whole plant,

will never prove injurious, but will generally be covered, in great part or entirely, by the advancing bark. The operation of cutting with the saw should not only be performed under the owner's eye, if possible, but each branch ought to be twice sawn, the first cut being merely to get rid of the weight of the branch, in order to prevent splitting, and the second cut very carefully made at the proper point, 1 or 2 feet lower down. The shoots of the first summer will, perhaps, be weak, but afterwards very strong, until a new head, capable of bearing every blast, has been completed; and we behold, instead of a tall and hide-bound victim to the winds, a sturdy, storm-defying ash, spreading its boughs in characteristic beauty. So, too, the old, misshapen, wind-shattered ash of the hedgerow may be taught to exchange its ragged blackened twigs, for those fresher branches which its venerable trunk is still quite able to nourish, when relieved from the burden that was slowly yielding to every storm, because its period of growth was past. (*Selby's History of British Forest Trees*, p. 92.)

*Rabbits and Gamekeepers great Enemies to Woods.*— I would recommend all proprietors of woods, if they wish to see them thrive, entirely to suppress the preservation of hares and rabbits; for they may rely upon it, there is not a class of men who do their employers so much injury as keepers. In the first place, they make a constant practice of gossiping with the men who may be at work upon their estates, thereby robbing them of much labour; and they keep the minds of their employers constantly in a state of excitement, rendering the improvement of woodland property almost impossible, by representing that this plantation must not be pruned, nor that wood felled, or the game will all be driven away. (*Gard. Chron.*, vol. i. p. 214.)

*Autumn Planting* is strongly recommended, because the damage done to the roots is repaired to a great extent; not indeed, except in evergreens, by the formation of new roots, but by the formation of granulations called a callus, which act like roots, and in fact are the commencement of those organs. (*Ibid.*, p. 715.)

*On certain Species of European Pines*; by Capt. S. E. Widdrington, R.N.: read at the meeting of the British Association, held at Plymouth in August last. — In this paper the author gives an account of his observations upon pines, during a recent tour in Austria and Upper Germany.

*Pinus austriaca*, or *nigréscens*, partly covers the plain of Austria, S. and E. of Vienna. It also occurs between Neustadt and the foot of the mountains that divide Austria and Styria, and on the hills near Baden; but, in ascending the range, it is soon displaced by the spruce and Scotch firs. Considering the elevation and geography of these habitats, the author thought that it must be placed in the zone below *sylvéstris*: at the same time there is no question that it is sufficiently hardy to resist any cold to which it is liable to be exposed in Great Britain. This species is very nearly connected with *P. taúrica*, or *Pallasiana*. The foliage is scarcely to be distinguished; but, on comparing the cones of the two species as grown in the Botanic Garden at Vienna, the author was struck with the difference in the form of the scales. From the quick growth of this tree, the great beauty of its foliage, which is long, thick, and tangled, and of the deepest green, as well as the great value of the timber, which the Austrian woodmen consider superior to that of *P. sylvéstris*, it cannot be too strongly recommended to the attention of planters. It is equally fitted for the forest or the park, for use or for ornament, and its deep tints would form an admirable contrast with the light and transparent foliage of the elegant *Pinus hispánica*; and it cannot be too generally used as a substitute for the *Pináster*, which has rather unfortunately been tried in some parts of the West of England, the timber of that species being comparatively valueless, and in every other respect inferior to *Pinus austriaca*. The author strongly urged on those who have the care of making fir plantations for future utility, to plant the evergreens which are to remain at the requisite distances, and to have the fillings up entirely of larch. He was of opinion that by adopting this method, several advantages accrue. The woodmen make no

mistakes in selecting during the process of thinning, and no spaces are left too open or too close. The evergreens, which require more or less care when young, are more readily looked after, and their places supplied where necessary in case of failure. The larch should be planted a year or two before the evergreens, by which time the grass is grown, and affords a shelter and protection against the destruction of game, &c. The trifling difference in the shelter between the evergreen and deciduous species is more apparent than real, and is more than compensated by the superior value of the larch thinnings, and the additional fertility imparted to the soil by the fall of the leaves. By having only a definite number of evergreens, the landlord can afford to have better sorts, and expend more care upon the rearing them.

*Pinus pumilio*.—The author had found the difficulty of obtaining information respecting this curious tree so great, that if, from inspection of the beautiful specimens at Dropmore, and in some other collections, he had not been satisfied of its being a distinct species, he might, in the summary mode of compilers who treat on trees they never saw in their native forests, have set it down as a “mountain variety” of some other species. All doubt, however, on the subject his late tour in Upper Germany has completely enabled him to remove. He first met with it, though sparingly, in Upper Styria. In the Saltzkammergut it is abundant, though high up, and above the Scotch and spruce, which form the mass of the forests in that beautiful region. By far the largest portion was met with in the Bavarian Alps, which it inhabits from the base almost to the summit, and in every sort of ground. An extensive swamp, or morass, adjoining the Chiemsee, the principal lake of Bavaria, is covered with it; and the effect of its dwarf and even surface a few feet above the ground is curiously contrasted with the lofty forests of spruce and Scotch fir which surround the marsh wherever the ground is sufficiently dry to bear them. Although it flourishes in this strange locality, where no other fir or scarcely any other tree can exist, marshy ground is by no means its only or favoured habitat. In the neighbouring mountains, where it is extremely abundant, the author found it at the base of the chain. In the dry gravelly beds of the torrent, it gradually creeps up the arid limestone to the very summit of the range which separates Bavaria and the Austrian Tyrol, living up to the very limits of trees. When seen in these situations from below, it could not by the unpractised eye be distinguished from furze or gorse. The peculiar form of this tree consists in its having no regular leader. Immediately above the ground it divides into a number of smaller stems and branches, which either sweep along the ground, their extremities pointing upwards or rising at once at an angle of 30° to 45°, accordingly as the neighbourhood or the locality has permitted it to expand. Occasionally, and amongst countless thousands, the author did not see above one or two examples of an attempt to grow straight, and throw up a single stem; but the failure of attaining size or elevation shows, in these instances, the creeping and true habit of the tree. The height attained is rarely above 5 or 6 feet, the diameter of the largest trees being from 20 ft. to 25 ft., though this size is rare; and the appearance is so regular, that in looking over an extensive level planted with it, it is quite as even as the surface of a gorse cover. The foliage in form and colour resembles that of *P. uncinata*, but the leaves are shorter, though standing out in the peculiarly rigid manner of that species. The cones are small, dark-coloured, and differ from both *P. sylvéstris* and *P. uncinata*. From the localities it inhabits, it must be placed very high in the series, by the side of *P. Cembra* and *P. uncinata*. The author was the more particular in describing this singular species, in order to guard those who may not have the opportunity of seeing it *in situ*, from confounding it, as so many have done, with the stunted individuals of *P. Cembra*, *P. sylvéstris*, and *P. uncinata*, which are always found at the summit of their respective zones in the high Alps and Pyrenees, and have been confounded under the general name of *pumilio*. As to the economical uses of this tree, it is clear they amount to very little, its wood being only used for inlaying furniture, such as backs of chairs and the like. To those, however, who possess extensive parks, by planting them 15 ft. apart, and taking care of them during their



early growth, they would be curious and useful covers for game." (*Gard. Chron.*, vol. i. p. 534.)

*Shrubberies.*—The prunings and leaves which drop should either be dug in, or left to decay on the surface, and digging omitted, unless the object be to stunt the shrubs. (*Ibid.*, p. 6.)

*Pruning and Lopping.*—Close pruning and snag-lopping, leaving small live shoots upon the snag, are recommended by Dr. Lindley (*Ibid.*, p. 115.), and close lopping by Professor Henslow. (*Ibid.*, p. 131.)

*Cèdrus Deodàra*, the Deodar, or Holy Cedar of the Mountains, is a tree as hardy and fast-growing as the larch, more valuable in its timber, and with the evergreen beauty of the cedar of Lebanon. Of all trees of British India this is incomparably the most important to England; it has every good quality, and no bad one. (*Ibid.*, p. 699.)

*Araucària imbricàta* has been raised at Plymouth, by pricking the seeds into the ground only a third of their length, with the narrow end downwards. (*Ibid.*, p. 293.) It has been raised in large quantities at Liverpool, and various other places, and plants are now offered for sale by the 100, at very low prices.

*Quèrcus fastigiàta* and *Q. àlba* grow much better when grafted on the common oak, than when on their own roots. (*T. Rivers*, in *Gard. Chron.*, vol. i.)

*The Terms Red and White Oak* are not applicable to two different species of oak as such, but to two different states of either of the British species. (*Gard. Chron.*, vol. i. p. 102.)

*The Sweet Bay* should never be cut down after it appears to be killed with frost; for it sometimes happens that its leaves, though hard, brown, dry, and to all appearance dead, have gradually recovered their green colour, and even, in some cases, been completely restored to life. (*Ibid.*, p. 531.)

*The Savine.*—*Juníperus Sabina* is a splendid lawn plant, when left to take its natural growth in an open space and kindly soil. A plant on my lawn, 25 years old, measures 22 yards in circumference. Its branches radiate from a single stem, which is invisible in the centre, feathering all round, without gap or blemish, down to the grass, and rising only about 3 ft. in the middle. It is at all times a pleasing object; but in the spring, when it has put forth its tender shoots, or in the autumn, when bespangled with dew, it is particularly beautiful. (*P. P.*, in *Gard. Chron.*, vol. i. p. 613.)

*Rhús Còtinus*, the *Venetian Sumach*.—A plant of this shrub, noticed in the *Gardener's Magazine* for its beauty twelve years ago, now measures 70 ft. in circumference at the extremities of the branches, and is strikingly handsome, its feathery panicles being so numerous as almost to hide the foliage. These, when they first expand, are of a yellowish green colour; but by exposure to the sun they acquire a fine deep red tint on their upper sides, which adds greatly to their beauty as they droop in masses, or wave gracefully in the wind. (*J. B. Whiting*, in *Gard. Chron.*, vol. i. p. 613.)

*Birches*, and other coppice woods, are said by Mr. Billington to push the most vigorous shoots when cut in the sap when the bud is swelling. (*Id. ibid.*, p. 565.) The experience of others, as well as theory, would lead to the preference of autumn.

*Tree Guards.*—A cheap and expeditious fence for protecting trees in parks against deer, horses, &c., may be made as follows:—Provide some stakes about the thickness of the wrist, 7 ft. in length, and tolerably straight; chop each a little flat on one side. Then get some iron hooping, a little thicker than coopers are in the habit of using for barrels; punch holes through it 6 in. apart (with one near each end); nail it to the stakes on the chopped side, 1 ft. from the top of them, and 1 ft. from the bottom; then raise it and bend it circularly round the tree, observing that the hoops are placed inside nearest the tree; the holes left at each end of the hoop are then clenched up with a nail, and the guard is complete. (*W. Brown*, in *Gard. Chron.*, vol. i. p. 26.) Stout wire is substituted for hoops in some parts of Scotland.—*Cond.*

*Tree Guards.*—A cheap, light, but strong fence, to protect single trees from

cattle, &c. Provide stakes of larch, willow, or other round wood, rather straight, 6 ft. long, and about 3 in. in diameter, making use of the waste ends by cutting them into 3-inch pieces; then take rod iron in 6-foot lengths, turned up 1 in. at one end and pointed at the other. Thus prepared, burn holes with a piece of the iron rod through the stakes, 12 in. from top and bottom, in the same direction; and through the centre of the small 3-inch pieces from end to end, having ten of each. Run the iron through them alternately, commencing with a stake, ending with a 3-inch piece; then bend the whole circularly round the tree, tying it to the other side by twisting the spare iron rod (about 10 in.) round the next stake. Thus any handy labourer may fence in trees in a simple and durable manner. But experience has taught me to drive three larch stakes, 3 ft. long, half-way into the ground, at equal distances, within the circle of the guard, to keep it in an upright position, or else cattle will force it against the trees, and the bark often gets injured by the upper part of the guard. Bamboo cane makes a very ornamental fence as above, and in some situations would be desirable. Trees should be strong, 8 or 10 feet high, and well rooted, before they are planted out singly, and ought not to be cooped up in large cumbrous cradles, as we often see, excluding rain and air. (*H. Bowers, Laleham, Gardener and Forester to the Earl of Lucan; in Gard. Chron. for 1841, p. 365.*)

*Dr. Boucherie's Mode of preserving Timber.*—The substance employed is impure pyrolignite of iron; and the method of saturating timber with it is to take advantage of the vital forces of a tree while in full vegetation, and to present the pyrolignite to the lower extremity of the trunk, as if it were food to be taken up into the circulation. Upon trial, this mode of impregnating the trunk was found perfect, the pyrolignite rising rapidly through all the permeable parts of the timber up to the extremities. The method employed is simple immersion of the lower end cut off, when small arms of trees are to be operated upon; but when the weight of large timber trees prevents their being so treated, without expensive tackle, the following contrivance has been adopted:—At the ground line a hole is bored horizontally through the trunk, so as to open a passage from side to side; a coarse-toothed saw is then introduced into the hole, and worked right and left horizontally, till about 1 in. in thickness remains undivided on either side; by which means nearly all the sap-vessels are cut through, and the trunk remains supported by two opposite points. The wound is then carefully closed externally with pitched cloth, except at one point, through which a pipe passes from a reservoir containing the pyrolignite. A few days in the summer or autumn are sufficient to saturate a large tree; for which purpose, pyrolignite to the amount of about  $\frac{1}{50}$  of the weight of the green wood is required. In France, the hoops of wine casks are made from branches of sweet chestnut. Some casks hooped with wood thus prepared, and others in the usual state, were placed side by side in a damp cellar; at the end of two years the natural hoops were rotten, while those prepared were unchanged. Timber thus impregnated becomes so hard and tough as to be very difficult to work. (*Gard. Chron., vol. i. p. 147.*) Subsequently, Dr. Boucherie succeeded in charging timber with his preparations during winter as well as summer. For this purpose, the timber is cut into any lengths that may be convenient; to the upper end of each log a water-proof funnel or bag is secured, into which the preserving fluid is poured. The fluid forces before it all the sap and air that the wood contains, and with considerable rapidity; and when the preserving fluid makes its appearance at the lower end, the operation is complete. (*Ibid., p. 231.*)

M. Biot, one of the most eminent of French men of science, thus expresses himself on Dr. Boucherie's experiments. After observing that they are founded on the discoveries of Hales, of the ascent of liquids in vegetables by the double power of suction belonging to their roots and the exhalation belonging to their foliage, he says,—“In considering the woody tissue as a natural mould, capable of being transformed by injection into a new body, endowed with special qualities for practical uses, M. Boucherie has conceived

a very useful and beautiful idea, but much more difficult to realise than operations purely chemical, because it applies to organised systems." (*Gard. Chron.*, vol. i. p. 348.)

*Dr. Boucherie's Mode of increasing the Elasticity of Wood, and of diminishing its Combustibility.*—He found that these most important results could only be arrived at by the use of a deliquescent salt. His experiments taught him that the elasticity of wood is generally in proportion to the quantity of moisture it contains, and that those qualities are universally lost when perfect dryness is produced. Such cases as appear to form an exception to this rule, are either dependent upon some particular structure of wood, or upon the alkaline salts which it naturally contains. Muriate of lime, an exceedingly cheap deliquescent salt, was employed with perfect success: a weak solution increases the elasticity and flexibility a little; concentrated solutions render those qualities excessive. Veneers of pine-wood prepared with a concentrated solution of muriate of lime became so pliable, that they could be twisted in any direction, or bent into a perfect spiral, without giving way. It appears probable that the same preparation will render wood durable; but, in the absence of proof of this, a fifth part of pyrolignite is added to the muriate. The casting, splitting, and shrinking of wood are all prevented by the same means; and, what is of much greater moment, its combustible qualities are almost destroyed. Upon this most interesting subject we quote the words of Dr. Boucherie. "As soon as I had discovered that a certain amount of moisture could be constantly maintained in wood by the employment of the earthy muriates, it became easy to conceive that by the same means I should not only diminish very considerably its inflammability, but also render the combustion of its charcoal difficult, in consequence of the melting of the earthy salts at its surface and in its substance, and so it is. Wood prepared with these salts catches fire with great difficulty, and burns to ashes excessively slowly; so that it may be regarded, for practical purposes, as incombustible. Two cottages (cabanes), exactly alike, were constructed; the one with prepared, the other with unprepared wood. To set them on fire, an equal quantity of combustibles was employed. The latter was burnt to ashes, while the inside of the other was hardly charred, the fire having been unable to maintain itself. These and other facts lead us to conclude that conflagrations might be rendered almost impossible, except in consequence of the inflammable materials that houses may contain." (*Ibid.* vol. i. p. 147.)

*Sir W. Burnett's Mode of preserving Timber* is considered to be as effective as Dr. Boucherie's. The substance used is a chloride of zinc, which, applied to vegetable tissue, is found to protect it against all the ordinary causes of destruction without communicating any bad property to the substance operated on. It has been found particularly effectual in the preservation of canvass, and might doubtless be employed to increase the durability of garden mats, and probably, also, of thatch for cottages. (*Ibid.*, p. 411.)

*Fastening down Plants in Flower-Beds.*—Instead of pegs, Mr. Beaton employs matting cut into lengths of 4 in., and these divided into three or four pieces: he doubles these pieces round the shoots, and fastens the ends of the matting in the soil with a small dibber. In this way, he says, a boy or a woman may train and tie down all the plants in a flower-garden in less time than it would require to procure pegs, while the work is much more neatly done than if the best pegs had been used. (*Ibid.*, p. 430.)

*Growing Annuals in Pots.*—Fill the pot to about one third or one half of its depth with wet moss, pressed very close, and over that put rich light soil, in which the annual seeds are to be sown, or young plants are to be pricked out. Place the pot in a saucer, and supply water to it. The moss absorbs the water freely, and parts with it slowly. (*Ibid.*, p. 484.)

*Budding Roses.*—The bud for insertion is taken off the shoot very close to the eye; the tip or part of the bark below the bud is cut off quite close, to allow the bud to be pushed closer into the stock without being bruised. It then requires only to be tied above the bud, and a composition applied to

exclude the air and keep the bud cool, consisting of two thirds cow-dung and one third stiff loam. The bud requires no untying, and gradually grows so closely into the stock as hardly to be distinguished from a shoot, and is not so liable to be blown out or injured. The composition is applied in a liquid state, with a small brush. (*Henry Curtis*, in *Gard. Chron.*, vol. i. p. 453.)

*Pruning Roses.*—The large showy roses that flower in June and July should be pruned in February. As many of the strongest young shoots as the tree is capable of supporting should be left, and the rest cut out; the branches left for flowering should be shortened back about one third, and those intended for next year's wood to about three buds. By this method of pruning I have many roses with shoots from 3 ft. to 6 ft. long, covered with blossom-buds. Those standards which have long shoots are hooped over each other, and produce a beautiful effect. Those dwarfs that admit of it have their shoots pegged down, or, if planted close together, they are intertwined, and thus the ground is covered with roses: if a little attention is paid to colour, a very pleasing effect may be produced. The young shoots intended for the next season are allowed to grow erect; and have the full influence of light and air. My reason for this kind of pruning is, that, as rose trees usually begin to grow early, the first 12 in. of a shoot 3 ft. long are produced when the soil is moist and the sun has but little power; the second 12 in. are added when the soil is becoming drier, and the sun has greater influence, in June, July, and August, and on this part of the shoot the best flower-buds are formed; the last growth takes place in the autumn, when the days decrease in length, and consequently this part of the shoot is not well matured. Roses should always be thinned in summer, to increase the strength of those shoots intended to produce flowers next season. In November I cut back the arched branches, and cover the ground with a coat of well rotted dung, and in the spring peg down the young shoots, as above described. (*R. Arnott*, in *Gard. Chron.*, vol. i. p. 117.)

*Propagation of Pinks.*—The pink is propagated by Mr. Mearns, something after the manner in which he coils the vine. He makes the soil much firmer than is usually done in the general manner of piping. "I do not use a dibber to plant with, but my fore-finger. I lay the lower end of my slip *horizontally* upon the surface of the soil, and so press it down into it; when, from the firmness of the soil, the slip is compelled to clip round the end of the finger, with the other hand I turn up the top to its perpendicular, and press the lower end down till the tail is about half an inch beneath the soil; I then make the soil firm, and the operation is complete. If the slips are too long, I cut them up to a joint, to a suitable length. I have slipped off hundreds, and have not even cut off the rag left on in slipping, and by the above process not one cutting has failed; yet it is better that the ragged end be cut off, either with a sharp knife or with scissors, which is generally the most expeditious method. I planted 1700 slips this last season, not twenty of which missed, and all my plants are firm and stocky." (*Ibid.*, p. 19.)

*Culture of the Amaryllis.*—Directions are commonly given to repot the plants as soon as they show flower, or before they begin to grow. "When first I cultivated amaryllis I pursued this plan, to the destruction of many of my bulbs, and whenever I have recurred to it since, or seen it tried by others, the same effect, either of complete or partial decay, has followed. If amaryllis be shifted into fresh pots, either soon after the leaves die off, or just before they begin to grow, the whole of the young roots perish, and decay so begun extends to the coats of the bulbs, forming a canker which it is almost impossible to cure. The management which I should recommend is invariably to repot such bulbs as require it when their foliage is in full vigour or still growing, say in June or July, or earlier, according to the treatment they have received. When the foliage dies at the tips, water should be gradually withheld, and the bulbs kept dry till the flower-buds appear. When the stem is half-grown water may be administered very moderately, but the plant should not have much till its leaves are 6 in. long." (*Gard. Chron.*, vol. i. p. 629.)

*Crinum capense* is a hardy amphibious bulb, strongly recommended by Mr. Herbert for covering small islands, as affording by its abundant arched foliage the best possible covert for wildfowl, and producing an abundant succession of beautiful flowers throughout the summer, and even the autumn. This plant is equally capable of flowering and ripening its seed, when planted in a border, or 2 ft. under the surface of the water, but thrives best in a border with abundance of water, or in a rainy season. It would be best planted a little above the level of the water. The seed sprouts as soon as it is ripe, and the young plants should be sheltered in pots the first and second winter, and then planted out, taking care that the weeds do not smother them while young. The bulbs, when full-grown, are so hardy, that, although they are natives of the Cape of Good Hope, I have had the neck of one, which had been left standing in water, imprisoned in ice 2 or 3 inches thick for a fortnight, without injury to the plant. Nursery gardeners might easily raise it from seed to sell it by the hundred. (*Gard. Chron.*, vol. i. p. 581.)

*Roscœa purpurea* has for many years been cultivated in the open air in the Edinburgh Botanic Garden, with no other protection than a little tan thrown over the border in winter. (*Ibid.*, p. 149.)

The *Marchioness of Exeter Camellia* is the finest variety in cultivation. The flowers are between 5 in. and 6 in. in diameter, and very regularly double. The colour is a bright deep rose. Raised from seed of Middlemist's by James Priaux, Esq., of Guernsey. (*Ibid.*, p. 215.)

*Salvia patens*, with its deep blue flowers, makes a splendid bed when pegged down, and the flower-spikes pinched off till the shoots nearly cover the bed. (*J. B. Whiting*, in *Gard. Chron.*, vol. i. p. 582.)

*Abutilon striatum* strikes throughout the winter from two joints in two or three weeks: 150 plants were obtained from one in a single winter by John Halliday. (*Gard. Chron.*, vol. i. p. 213.)

*Abutilon vitifolium* has lived out of doors through the last severe winter in the neighbourhood of London. (*Ibid.*, p. 246.)

*Fuchsia discolor*, in Norfolk, and even in the neighbourhood of Edinburgh, becomes a shrub 4 or 5 feet high, uninjured except by very severe weather. (*Ibid.*, p. 596.)

*Physianthus albicans*, which will cover many yards of wall in a short time, has the remarkable property of catching moths. The moth is held fast by the pressure of the cartilaginous anther upon the proboscis, which is inserted between it and the stigma. (*Ibid.*, p. 685.)

*Oxalis Acetosella*, or wood sorrel, makes an excellent edging for shaded walks. It requires no cutting, except to keep it within bounds, and for that once a year will suffice. (*Ibid.*, p. 685.)

*Canker in Fruit Trees* is often produced by heading them down in spring, while it does not occur if that operation have been performed in autumn. If the operation of lopping off the branches preparatory to grafting is deferred till spring, the sap being then in brisk motion, bleeding, or an extravasation of sap, takes place, which deluges the scion, and as the sap becomes chemically changed or decomposed it kills the alburnum, often to a considerable extent, along the stump on which the scion is placed; whilst the sudden privation of circulating sap, by lopping, deranges the economy of the remaining portion of the plant. Such limbs as are to be grafted should be decided upon long before the season for performing the operation; they should be shortened before the commencement of vegetation, as in the case of pruning, to within a little of the place where the graft is intended to be placed. No harm will be done by taking off a little more, so as to make a fresh section, at the time of grafting. By following these directions the process of healing, instead of decay, will proceed with the advance of vegetation. (*Ibid.*, p. 629.)

*Vines are made to break* by turning out the shoots through holes in the front lights. First turn out the whole shoot, except 2 or 3 feet at the lower end. Then, after forcing has been commenced, and the buds on that

part of the shoot which is within the house have developed, draw in two or three joints more till the buds on these are developed, and so on, until the whole of the shoot has been introduced. (*Gard. Chron.*, vol. i. p. 614.)

*Preservation of Grapes.*—When grapes hang long on the vines they prevent them from being pruned; but that it is quite possible to keep grapes in as high a state of preservation as when left on the vines, if not more so, I have proved by the adoption of the following method. In the last week in December, or first week in January, I prune the last house of grapes, which were ripe in September, and cut the whole of the grapes remaining, with a joint or two, or more, of wood below the bunch. I make a clean cut, and apply sealing-wax, as hot as can be used, to it, and seal the wood closely, so that no air can enter the tissues communicating with the bunch. I then hang the bunches up on cords suspended across a closet in a cool airy room, taking care that they do not touch each other, and after this they are cut down as wanted. In this way the White Muscat of Alexandria was kept in 1840, until the latter part of May: of course they were slightly shriveled, yet not so much as they would have been had they remained on the vines. In 1841, Black Lombardy, Black Hamburg, and White Muscat of Alexandria were kept until the fifth of February, in an excellent state of preservation, most of the berries being quite plump and firm. To succeed, much depends on the situation where the grapes are preserved; they must not be exposed to a current of warm air, nor yet be so damp as to cause mould. The bunches being well sealed is a most important point to be attended to. (*G. G. Watson*, in *Gard. Chron.*, vol. i. p. 663.)

*Mr. Hayward's Manure for Grapes.*—I have tried a great variety of compounds as food, and have found that one quart of cider or cider grounds, added to two gallons of water, brings a grape vine to a more perfect prolific state than any thing else. This mixture must be supplied in such quantity as will saturate the earth, like water, to the depth of the roots, and all over the surface occupied by the roots. It must only be given once in the year; and, if repeated the second year, its good effects will be sustained for several years afterwards without further supplies. The apple and pear, and the fig, are alike benefited by this compound. (*Ibid.*, p. 413.)

*Keeping Fruit.*—R. Tongue observes, "if you wish to mature your fruit for immediate use, put it into heaps that it may sweat, and your object will be attained; but, should you desire to keep your fruit a long time, place it in an underground room, one apple or pear deep, upon shelves of flag or slate, or any other material which will rapidly conduct away the heat generated in the fruit during its sweating, or which will check its fermentation, so as to postpone its decay." (*Ibid.*, p. 717.)

*Raspberries* have grown fifteen years on the same spot, and continued in high bearing. (*Ibid.*, p. 213.)

*Thinning Pears*, and even apples, when the fruit is set, and again in July or later, is strongly recommended (*Ibid.*, p. 37.); and again by Mr. Whiting (*Ibid.*, p. 69.).

*The Scale on Peach Trees* may be destroyed by painting them over with diluted clay when the buds are beginning to swell. Two coats of the paint will be necessary, and the trees should be covered during rains for a fortnight. When the clay drops off it will bring all the scale with it. (*John Kyle*, in *Gard. Chron.*, vol. i. p. 70.)

*Preserving Pears on the Trees.*—Pears have been preserved on dwarf trees by matting up, as is done with currants and gooseberries, by Mr. Crace of St. John's Wood. In this way Marie Louise pears were kept in perfection till Christmas. (*Gard. Chron.*, vol. i. p. 5 and 6.)

*Wild Crab Apples* exist in two distinct forms in our hedges; one pubescent and the other perfectly glabrous. The latter is supposed by Ray to be the effect of a certain degree of cultivation. (*Leighton's Flora of Shropshire*, p. 199.)

*Pears.*—The wide departure of many varieties of pear from their usual period of ripening is noticed in detail by Mr. Rivers, who recommends

Hacon's Incomparable as an excellent winter pear, which produces better fruit on a standard than against a wall. (*Gard. Chron.*, vol. i. p. 20.)

*Keeping Apples and Pears.* — Apples and pears are kept better in a cool cellar with a humid atmosphere than in a perfectly dry fruit-room. Apples exhale a sort of natural varnish sufficient to exclude all moisture, and which checks the too rapid perspiration of the fruit. (*Ibid.*, p. 701.)

*Packing Fruit for Carriage.* — "I beg leave to suggest the following plan, which is found better than any other for insuring the safe transport of delicate philosophical instruments, and is equally adapted to ripe fruit. Having packed the fruit in an inner case with soft cotton, or whatever may be deemed best for the purpose, let that inner case be suspended within an outer one by lines or cords. Suppose, for instance, that the outer case is 2 or 3 inches clear all round the inner case, and the eight cords proceeded from the eight outer corners of the one, and were fastened to the eight internal corners of the other case. In this way, whatever side was uppermost, the inner case would be suspended from the four upper cords, the four lower ones serving only to steady it, and to prevent its swinging against the outer case. If the whole be turned upside down, the functions of the cords become reversed, so that they must all be strong enough to perform either office, about which, however, there is no difficulty. I have bestowed great attention on all the known modes of checking vibration, and have no hesitation in recommending this as incomparably superior to any stuffing of moss, hay, or shavings; and it may, perhaps, have the additional merit of preventing the chance of imparting unpleasant flavour, which might arise from a compact mass of vegetable matter between the two cases. It is not essential to use exactly eight cords, nor to fasten them from angle to angle of the cases. Any arrangement by which the inner case is suspended, and, at the same time, prevented from swinging against the outer case, will equally well answer the purpose. A still better plan, for those who have frequently very choice specimens of fruit to transmit, would be, to insulate the inner case by spiral springs, with the addition of small portions of felt or woollen cloth, to limit the vibrations, on the same principle as my supports for microscopes; the springs would be very cheaply made, and would avoid the repeated trouble of packing or tying; but the cords will do extremely well." (*A. Ross, Regent Street*; in *Gard. Chron.*, vol. i. p. 485.)

*Roots of Fruit Trees.* — The roots of all fruit trees should be kept as near the surface of the ground as possible, in order that they may profit by the warmth of the sun and a free communication with the atmosphere. (*Gard. Chron.*, vol. i. p. 21.)

*The Spanish Filbert* does not throw up suckers, and Mr. Rivers has suggested the idea of grafting the common filbert on it. (*Ibid.*, p. 69.)

*Gooseberries* are recommended to be grown below some higher grounds, so that they may have the benefit of the water that comes down from above. This shrub, to bear large fruit, requires a warm and rich soil, well supplied with moisture from below, and a situation sheltered from the wind, and having the full benefit of the sun. The watering-pot is of little use to gooseberry bushes, if they have no other supply. (*Ibid.*, vol. i. p. 613.)

*Gooseberry Cuttings* of winter's wood always succeed best when the articulation, or socket which joins the young branch to the old, is pulled out along with the cutting when separated from the bush. The buds should all be taken off, except from four to six at the top of the shoot. (*R. Lyburn*, in *Gard. Chron.*, vol. i. p. 486.)

*The Club in the Cabbage Tribe* has been prevented by filling the dibble holes with quicklime before inserting the plants. Planting in dry soil, and not giving water, appear also to be more or less a preventive, because the insect which produces the club chooses moist ground in which to deposit its egg. (*Gard. Chron.*, vol. i. p. 717.) To prevent the club in cabbages: — Take 1 gallon of fresh soot and 1 lb. of pounded saltpetre, mix them with water to the consistence of coal tar; dip the root of every plant in before planting. By

this simple method I have not got a single club-rooted plant in the garden, although many of them had begun to club in the seed-bed. (*G. Fielder*, in *Gard. Chron.*, vol. i. p. 662.) Clubbing in the *Brássica* tribe is prevented by putting a little quicklime in the hole while planting. (*I. Hislop*, *ibid.*, vol. i. p. 613.)

*Asparagus* is blanched by covering with sand by Mr Buchan at Blythfield, who finds the branch part more tender, the colour more delicate, and the flavour improved; nor are the plants so liable to rot in winter as when the beds are covered to a great depth with dung and soil. (*Gard. Chron.*, vol. i. p. 86.) Sand laid over the drills of newly sown peas from  $\frac{1}{8}$  in. to  $\frac{1}{4}$  in. in thickness, is an effectual remedy against mice, and also small snails. (*Ibid.*, p. 107.)

*Oxalis Déppeii* has been cultivated in Belgium for culinary purposes. The young leaves are dressed like sorrel, in soup, or as a vegetable; they have a fresh and agreeable acid, especially in spring. The flowers are excellent in salad alone, or mixed with corn salad, endive of both kinds, red cabbage, beet root, and even with the petals of the dahlia, which are delicious when thus employed. When served at table, the flowers, with their pink corolla, green calyx, yellow stripes, and little stamens, produce a very pretty effect. The roots are taken up in September or October, and preserved through winter in a cool cellar. They are gently boiled with salt and water, after having been washed and slightly peeled; they are then eaten like asparagus, in the Flemish fashion, with melted butter and the yolks of eggs. They are also served up like scorzonera and endive, with white sauce. They form, in whatever way they are dressed, a tender, succulent dish, easy to digest, and agreeing with the most delicate stomach. The analogy of the root with salep indicates that its effect should be excellent upon all constitutions. (*Professor Morren*, in *Gard. Chron.*, vol. i. p. 68.)

*Comfrey* (*Symphytum officinale*) is recommended as a perennial spinach plant; and the young shoots, blanched by being forced to grow through loose soil, as a substitute for asparagus. (*Gard. Chron.*, vol. i. p. 262.)

*Victoria Rhubarb* can be gathered, in a young and tender state, in much greater bulk when forced, than in the case of other varieties. (*Ibid.*, p. 167.)

*Myatt's Pine Strawberry* Mr. Lymburn found to grow profusely on light, rich, sandy, alluvial soils near the sea, where other strawberries are apt to throw out too many runners. (*Ibid.*, p. 550.) About London it is very difficult either to grow or fruit.

*Fúchsia fulgens* produces fruit not unlike a small gherkin, which, when quite ripe, turns to a pale yellow, and comes off at a touch. "They are, to my taste," says Mr. Herbert, "as good as any grapes, except the high-flavoured sorts of muscat." (*Ibid.*, p. 685.)

*Trifolium incarnátum* is found of great value in filling up blanks in fields of common clover. Examine the field immediately after the corn crop, among which the clover is sown, is cut and carried, sow *T. incarnátum* in the blanks, and hoe, rake, or harrow it, as most convenient. (*Ibid.*, p. 645.)

## ART. II. Foreign Notices.

### GERMANY.

*LOUISAINE, near Dessau.*—On the 18th of December last the duke's garden here sustained great damage from a tremendous storm. A great many trees, particularly of the genus *Pinus*, were either torn up by the roots, or had their branches broken. The tree which suffered the most was the largest and finest of the scarlet oaks (*Quercus coccínea Wangerh.*): it was thrown down, and completely uprooted. This magnificent tree was one of the largest, if not the very largest, in this part of the country, and, perhaps, in all Germany. It measured 90 ft. in height; its circumference, at 6 ft. from the ground, was  $4\frac{1}{2}$  cels; and at the height of 43 ft., where the stem divided into two principal



branches, it measured 3 ell. I cannot exactly tell its age, but it must have been between sixty and seventy years old; because it, and several other large specimens in this garden, and also in the garden at Worlitz, were planted among the very first in Germany by the never to be forgotten Duke Francis, the then wise regent of Anhalt-Dessau. It was a very splendid beautifully grown tree, with a most magnificent head, which made a great resistance against the storm; and it certainly would have withstood the shock, had its stem not received a severe injury, near the root, some years before. It grew on a small elevation, near a pond, in a strong and productive soil, composed of loam and marly clay. (*M. Richter, Court Gardener.*)

*Extracts from the Epistolary Correspondence of Edward Otto, during his Voyage to Cuba, and his Abode there.* (Continued from p. 525.)—On the 5th of January we arrived safe in the harbour of Havanna; and what a delight it is for those who have been floating on the ocean for more than two months again to behold the land! More particularly so for me, as the treasures of the tropical world here presented themselves; and, although we could distinguish groups of trees on the coast of St. Domingo and the south coast of Cuba, by the help of the telescope, we now saw with the naked eye, and in their native soil, the lofty palm and the flowering agave. All the inconveniences of a long voyage were now forgotten; but we were obliged to remain three days on board, till we got permission to land, on account of the necessary investigation into the health of the crew; and this was delayed one day on account of the intervening Sunday. Who could have found fault with us, if, on presenting the guard with half a dollar, and the promise of returning to the ship before nightfall, we had, without this permission, got our unconquerable desire gratified by setting our foot again on dry land? The harbour, the view of the city and the hills lying behind it, however splendid they might be, did not please us long; the merchantmen, the French ships of war, which came here with the sick or wounded from St. Juan d'Ulloa, and also our nearest neighbour, the Prince de Joinville, were not sufficient to amuse us: we felt we must, with or without permission from the authorities, get on shore.

A Spaniard, who spoke both French and English, conducted me, on the 8th of January, to the governor of the island. The general received me in the most friendly manner, conversed with me more than half an hour in the French language, and then gave directions to his secretary to write out for us a passport, which would remove all difficulties during our excursions throughout the island. Permission was then given to have our luggage on shore; and it passed with but little trouble at the custom-house, as, of about thirty packages, only three were opened.

We next began to think of a lodging; and the room in the inn which we selected had no windows, instead of which there was a hole with a grating, and a shutter to cover it. Glass windows are not in use here, and even cupboards and chests of drawers seem not to be known, as the apartment only contained a bed, a table, and some chairs. It was an agreeable surprise to find that our landlady spoke both French and English, as we were obliged to make our way with these languages; German being only spoken by a few Germans who had settled here, and the language of the country, a dialect certainly of the Spanish, and which I began with assiduity to study, being, to speak proverbially, really Spanish to me\*; and the negroes only pay attention to expressive signs and blows, to which I have not yet become accustomed.

Immediately on entering the town we were struck with the sepulchral monument of Columbus, situated in a beautiful square, where his corpse was

---

\* When a thing is very difficult, or cannot be understood, it is common in Germany to say, "*Es kommt mir Spanisch vor.*" "It is Spanish to me."—*Translator.*

brought by sea to find terrestrial repose. It is ornamented with a most beautiful specimen of *Oreodóxa régia*, and a *Cocos nucífera*. The square is regularly divided into compartments by broad paths laid with flat stones; and planted with *Citrus* and *Nèrium Oleánder*, some oreodoxas, cocos, *Artocárpus incisa* about 30 ft. high with an immense head, and a species of *Bómbax* from 60 to 70 feet high, and 6 ft. in diameter at a foot from the ground, cassias and mimosas, and several other trees apparently unknown to me. On perambulating the town, I found it very large, and regularly built; the houses one and two stories high, and no paved streets, but only a causeway. From the great number of shops, in which all kinds of objects can be purchased, the town has quite a European appearance; and it is only the smell of dried meat and fish, the same odour which is emitted from the abodes of the negroes, that destroys the illusion.

It is natural to suppose that I went as soon as I could to visit the botanic garden here, which is managed by a M. Pedro Auber, by birth a Frenchman. If I had not been told it was a botanic garden, I should rather have taken it for a nursery of different kinds of trees. It is divided by broad paths, many of which are so wet and marshy that you can hardly find a firm place to set your foot on. From what the governors told me, the garden is at present on the decline, but they hope soon to bring it into a more creditable state. Its greatest ornament is one which is wanting in all European gardens, viz. a splendid avenue of oreodoxas, and of these there are about eighty in each row, 70 or 80 feet in height, and covered with blossom and fruit; and not less beautiful are the rows of *Casuarina equisetifolia* vera, called here the cedar. There are also beautiful specimens of *Cocos nucífera*, *Phœnix dactylifera*, a fan palm unknown to me, *Cycas revolúta*, *Citrus*, *Laúrus*, cassias, mimosas, *Bambusa arundinácea* in extremely high hedges, splendid specimens of *Artocárpus incisa*; clusias, probably álba and rôsea; several species of *Sida*; large surfaces covered with *Pòthos*, *Caládium* bicolor, and other *Aróideæ*. The trees are entwined by convolvuluses and ipomœas. The *Euphórbia pulchérriima*, with its innumerable blossoms and beautiful red bracteas, the *Cánna índica*, and several other species, are here seen growing in the deepest marshes; also the most formidable hedges of opuntias, yuccas, and agaves. Greenhouses and hotbeds are nowhere to be seen in the garden; and there are but a very few plants in pots, such as *Orchídeæ* and euphorbias, which did not look well; and, besides the opuntias, only the *Cereus speciosissimus* and *triangulàris* are in the garden. Our simple balsams, *Tágetes pátula*, and other Mexican summer flowers, were seen here and there among the trees; and this was all M. Auber, with the most friendly feeling and unlimited goodwill, had to offer me.

On the same side of the city is situated the Pasco de Tacon, so named after the late Governor Tacon, who, however, only got it made at the public expense; and it is, indeed, a very large public promenade. It consists of a carriage way 2560 ft. long, 40 ft. broad in the centre for carriages, and 26 ft. broad at each side for foot passengers. The whole descends from both ends to the middle, so that a general view is obtained from the two extremities. There is a circular piece of ground at the entrance, surrounded by a wall 5 ft. high, and the gate is guarded by two marble lions. In the centre of this circle stands a statue of Charles III., with the following inscription: "A Carlos III., el Pueblo de la Habana, anno MDCCCIII." From this circle you proceed to the avenue; and at about 600 ft. distance there is another circle, surrounded by two rows of beautiful lofty *Casuarina equisetifolia*, and in the centre a pillar 20 ft. high, on a pediment 10 ft. high. After another space of 600 ft., you find a similar circle ornamented with a basin and fountains, and a pedestal with five urns and four marble figures. The avenue is twice more divided in this manner, with 300 ft. and 260 ft. between the circles; and at the other end is one similar to that at the entrance, with a pillar 40 ft. high in the centre; and the gate is ornamented with two urns, 24 ft. in height, standing on pedestals. The trees in the avenue are *Aleurites tríloba*, several species of *Ficus*, *Phyllánthus*, and *Cedrèla*. There are stone

seats, and others of turf, among the trees; and a beautiful hedge of splendid monthly roses forms the limit of the promenade. Large stones are laid down by the pedestal of the column in the last circle, among which thrive luxuriantly *Adiantum formosum*, *Pòthos crassinervis*, *Arum discolor*, and several others. On the left of this Pasco there is a railroad, not quite finished; and on the right are fields and gardens, in which there are several beautiful specimens of *oreodoxas*, *Phœnix dactylifera*, and *Pandanus utilis*, giving a splendid character to the landscape. An avenue leads from the former-mentioned circle to a house on the right, the property of the late governor, and laid out in the English style, with a boundary, like the other, of a hedge of roses; and in the avenue are *Ficus populifolia*, *Mangifera indica*, *Aleurites triloba*, with *Nerium splendens* fløre álbo et ròseo standing between. The garden cannot be called large, but has a path 300 ft. long, beautifully ornamented with hedges of roses and *Mammèa americana* on both sides. The orange trees, being in blossom, delighted me with their fragrant perfume, and the luxuriant growth of the following plants quite enchanted me; viz. *Hibiscus Ròsa sinensis*, *Delphinium sinense*, *Euphòrbia pulcherrima*, *Tradescantia discolor*, *Nerium splendens*, *Clusia álba*, *sophoras*, *mimosas*, *Citrus myrtifolia*, *pomegranates*, *Pandanus utilis*, *Hedýchium*, *Cánna*, and *cypresses*. On ascending the height before the outlet-door (ausgangsthore) of the Pasco, on which are a castellated building and a powder magazine, a most delightful view is obtained over the city and the sea, the hills on the right and left, and the Pasco in front, from which a long bridge leads to the city over a valley where no water flows.

The Pasco, at five and six o'clock in the evening, is the rendezvous of all the fair in Havanna. Attired in the most elegant ball costumes, they drive up and down in their two-wheeled carriages, drawn by one horse, and a smartly dressed negro sits upon the horse. The carriages are always in four rows, two coming and two going. There are generally three ladies in one vehicle, and they are very seldom accompanied by a gentleman. However simple the whole may appear from description, I must confess that so many carriages rattling along among the foot-passengers have a very lively appearance. The show and splendour, however, accord with the high price of every necessary of life, and it even far surpasses that of London. Half a real is the smallest coin in use; and I paid, in the cheapest inn I could find, 2½ dollars and 8 reals daily for my room, bed, breakfast, and dinner. A strong healthy man would not find it difficult to consume here as much bread alone, daily, as would procure him with us a substantial and excellent dinner or supper. From previous agreement, I was obliged to pay twenty dollars a month for the washing of my body linen. But should I make complaints when all my expenses are so liberally defrayed? I only hope that my exertions during this journey for the cause of science may be found useful, in proportion to the encouragement afforded me; and in this hope I now begin to set out on my excursions through the island. (*Garten Zeitung.*)

---

### ART. III. Domestic Notices.

#### ENGLAND.

*GEESE destroyed by eating Monk's-hood.*—What I am going to state is nothing about the long life of a gander, or the wonderful attachment which a goose has been known to show towards her master, but merely that a friend of mine had six geese poisoned by eating the roots of *Aconitum Napéllus* (monk's-hood); three died, the others were saved by disgorging the contents of their crops, which led to the discovery of their having eaten the roots. This circumstance shows how careful poultry-keepers ought to be, not to suffer monk's-hood to grow where their fowls frequent. Although the instinct of birds is wonderful, yet what I have just stated shows that they, like quadrupeds, will eat what is fatal to them.

*Instinct of Pigeons.* Speaking of the instinct of birds brings to mind that once I had a pair of pigeons of the croper kind from a friend. I confined them about a month, with the view of breaking off the thoughts of their former home, but as soon as they had their liberty they flew towards their old habitation; the hen arrived immediately, but, strange to say, her mate did not till two years afterwards. No doubt he was in confinement during that time. The flight to their old place was only  $4\frac{1}{2}$  miles, but what seems curious is, that a pigeon should recollect it after two years' absence.

*Habit or Instinct of the Virginian Nightingale.* I may add that a gentleman told me his Virginian nightingale imitated feeding its brood in the spring. I know of no instance of ornithologists noticing such a thing, but it is a question whether it be instinct or merely mechanical. If the bird had never assisted in rearing, I should say instinct, but otherwise mechanical, from former habits, perhaps in its native haunts. Many of our own movements, as well as those of birds, especially domesticated ones, are the effects of habit. — *J. Wighton. Cossey Gardens, Sept. 24, 1841.*

### SCOTLAND.

*Rhododéndron anthopògon* D. Don, Arb. Brit. vol. ii. p. 1148. fig. 954. — This shrub has lately flowered in the Edinburgh Botanic Garden, and in great vigour at Dysart House. At this place, which we had the high gratification of seeing in September last, the Countess of Rosslyn has taken great pains to form an unusually extensive collection of the different species and superb varieties of *Rhododéndron*; and, placed under the judicious management of the gardener, Mr. Blair, they thrive and flower in a manner not surpassed in any collection in Britain. Among these the rare species now described forms a dense bush. It was obtained from Messrs. Loddiges five years ago, and during each of the last three years it has flowered in the open border, abundantly in April, and partially in August. I am not aware that it has flowered anywhere else in Scotland. It is a native of the Himalaya Mountains, and extends, as we are informed by Dr. Royle, along the range from Nepal to Cashmere, never descending lower than 9,000 ft. above the level of the sea, but rising to an elevation exceeding 14,000 ft., with the last remains of woody plants; *Rhododéndron lepidòtum* and *Salix Lindleyàna* alone being found in company with it. (*Dr. Graham, in Edin. Phil. Jour., Oct. 1841, p. 395.*)

*An Agricultural Museum* is about to be established in Glasgow, on the same general plan as those in Stirling, Perth, and Edinburgh. Messrs. Drysdale and Lawson, seedsmen in Glasgow, are announced as the "interim secretaries and curators," to whom donations of every kind may be sent; and the patrons are Lord Belhaven and Sir John Maxwell, Bart., of Pollock.

*The "King's Knot" at Stirling.* — A rumour has reached us, to the effect that propositions have been made to level the "King's Knot," or round table, which adorns the royal park at Stirling, and transform it into a modern ornamental garden. The deed, if done, would be regarded as an act of Gothic barbarity by every lover of antiquity in Scotland. But we are well aware that such a proposition needs only seriously to be made to be almost universally scouted. This round table is unique of its kind in the northern part of the kingdom, and the round and oblong circles which are clearly defined, point out the place of royalty, and call to mind the times when deeds of courtesy and chivalry were here enacted under the eye of the princely James and the fair ones of his court, who, from the "Ladies' Rock," looked down upon the gay scene below. "Gray Stirling," with her towers, and town, and park, are classic ground, and have afforded materials for many a noble measure, from the days of quaint Sir David Lindsay to those of the lamented bard of Abbotsford. We should, therefore, look with honest horror on any attempt to disfigure one tittle of these olden landmarks by modern gewgaws. (*Glasgow Herald.*)

We were informed, when lately at Stirling, that it was the intention of the "Woods and Forests" to lay out some public walks in the neighbourhood

of the town, and that the space occupied by these and the accompanying plantations would include the "King's Knot;" but we have no idea that this would involve the destruction of this very curious piece of antiquarian gardening. On the contrary, the "Knot" would form an interesting feature in the walks, more especially if the partially obliterated parts were restored. We are further informed that the plantations proposed to be made along the walks would probably include a collection of all the trees and shrubs that would endure the climate; in short, that it would be an arboretum. The plan, we believe, was formed by the Messrs. M'Nab of Edinburgh, and the circumstance of employing these gentlemen on such an occasion does great credit to the Office of Woods. To return to the "Knot," the Messrs. Drummond of the justly celebrated Agricultural Museum of Stirling kindly undertook, in August last, to have the Knot surveyed, and a plan and sections made out for us, engravings from which we shall publish in the course of our tour which will be commenced with our volume for 1842.—*Cond.*

---

#### ART. IV. *Retrospective Criticism.*

*ROOTING Cuttings in Charcoal, and sowing Seeds in Snow.* (p. 152. 219. 252. 302. and 304.) — We are glad to find this practice beginning to attract attention in this country as well as in Germany. A writer in the *Gardener's Chronicle*, who had recently visited Munich, makes the following observations on what he saw in the royal gardens there. We would strongly recommend gardeners to try powdered charcoal simply as a substitute for sand in striking cuttings; and again, mixed with soil for growing plants, as practised by M. Lucas at Munich, and related by him in p. 219.

"By the kindness of Professor Martius, I was allowed to inspect the propagating apparatus in the Botanical Garden at Munich. It is so fully described by the inventor in the *Garten Zeitung* (see *Gard. Mag.* for June last), that little remains to be added, except to state the results. The strongest proof that the plan is good is, that it continues to act with the most complete success, although the author of it has been removed to Ratisbon; for it is well known that many plans are indebted for their success to the unwearied attention of the parent eye, and that, from passing into other hands, they are frequently allowed to languish and decay. Nothing can be more simple than the whole apparatus. It is nothing more than a common pit, with a flue along the middle, on which is a reservoir of water, the steam from which passes through the bed of charcoal, which is placed above it. Upon the charcoal small glass frames of the commonest kinds are placed, to exclude the air from the cuttings in their early stage. It may be suggested, and, indeed, would immediately strike any one who examines the apparatus, that the success may be owing to the moist heat in which the cuttings are constantly kept. No question it is so in part; but I am quite satisfied the extraordinary results I witnessed are quite as much owing to the menstruum of propagation as to the decided advantage above stated; and I doubt whether heat and sand, under any circumstances, would cause the quantity of roots to be produced which I saw there at the end of three weeks' insertion in the bed. It is necessary that the charcoal should be fine, but not in dust, which will consolidate, and prevent the fibres penetrating in every direction, as they do when it is of the proper size. In some part of the process, fine peat is mixed with the charcoal; but I think this is rather in the rooting afterwards, and that the first process of striking, in most species, succeeds best in the pure material. From what has been stated, it is clear the necessary apparatus is simple of application, and of little cost; a part of any flued pit, or one heated by hot water, would answer every purpose; though in any nursery, or even gentleman's establishment, the making one on purpose would be of trifling expense compared with the results, as, owing to the rapidity of the operation, a very small bed would suffice. With respect to the virtues of the charcoal itself

producing the results we are considering, I have little doubt that they consist principally in the porous and perfectly permeable nature of it. The heat and moisture are consequently present and passing through, without any saturation, or stagnation, or induration taking place. There may be something in the vegetative powers of it, but I imagine this to be the true cause of the superiority over any other material as yet known for propagation. Many of the plants on which it has succeeded are known to be the most difficult to strike. There is another valuable article (see *Gard. Mag.* for June, p. 302.) from M. Lucas, on the raising of seeds in snow. I have no doubt that this is a grand secret or marvel gained from nature, by the discovery of one of her own modes of operation. It is exactly analogous to the methods followed by nature in the High Alps; and there is no doubt the gentians, and other seeds of difficult growth, might easily be made to germinate by it. M. Lucas recommends sand to cover the young plants on their first appearance; but it is doubtful whether fine tan would not answer a better purpose. (*S. E. W., Carlton*; in *Gard. Chron.* for August 21. 1841, p. 459.)

*Dáphne Cneòrum* and *D. Dauphínií*.— You do not, I think, sufficiently recommend to your readers the beautiful *Dáphne Cneòrum* or the *Dáphne Dauphínií*. I am told some persons find the former difficult to manage. We have no trouble with it. We keep laying it year after year, and so increase our stock while we preserve it in vigour. — *T. W. Banks, near Barnsley, June, 1837.*

---

#### ART. V. *Queries and Answers.*

*MR. PARKYNS*, the Author of "*Monastic Remains*" and of "*Designs for Laying out Grounds.*"— This gentleman, about the year 1800, began a work in folio, which contained designs for villas, including the details of the house as well as of the grounds. Only three or four numbers of the work were published, and it has now become very scarce. We know of only one copy in London, but the late ambassador Liston of Milburn Tower, near Edinburgh, who was intimate with Mr. Parkyns, possessed a copy in 1804, and this copy must doubtless have gone the way of the ambassador's other books. What became of these books we have been unable to ascertain; but, if any reader can inform us, or put us in the way of borrowing or purchasing the work of Mr. Parkyns alluded to, we shall be very much obliged to him. — *Cond.*

---

#### ART. VI. *Obituary.*

*AUGUSTUS PYRAMUS DECANDOLLE* died at Geneva on the 9th of September last. An individual of higher attainments as a botanist, or more respected as a man, did not exist.

*Prince Butera*, a Hanoverian officer, who married a Sicilian princess, and took her name, died recently. He was remarkably fond of horticulture, and introduced many German practices into Sicily, among others the culture of asparagus.

END OF THE SEVENTEENTH VOLUME.







THE  
GARDENER'S MAGAZINE,

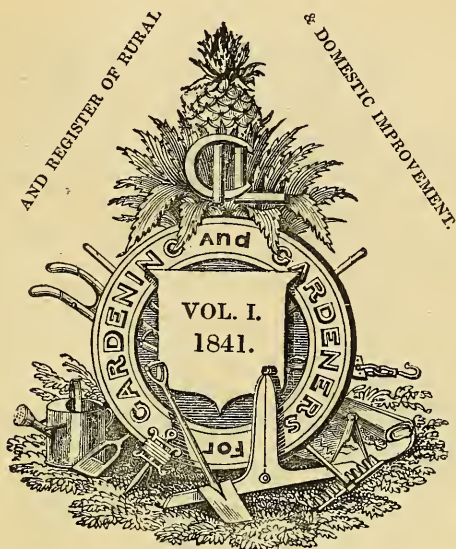

**THIRD SERIES.**

CONDUCTED

By J. C. LOUDON, F.L.S. H.S. &c.

AUTHOR OF THE ENCYCLOPEDIAS OF GARDENING, OF AGRICULTURE, AND OF COTTAGE, FARM,  
AND VILLA ARCHITECTURE, AND OF THE ARBORETUM BRITANNICUM AND  
SUBURBAN GARDENER.

---

LONDON:

PRINTED FOR THE CONDUCTOR;

AND SOLD BY

LONGMAN, BROWN, GREEN, AND LONGMANS,  
PATERNOSTER ROW;

AND A. AND C. BLACK, EDINBURGH.

1841.

# EXPLANATION

OF

## THE CHARACTERS, ABBREVIATIONS, AND INDICATIONS

USED IN BOTANICAL AND FLORICULTURAL NOTICES.

| <i>Habit.</i>                   |                | tive country.  |                   | p poisonous.    |               | Spot spotted.  |           | Umb umber- |               |
|---------------------------------|----------------|----------------|-------------------|-----------------|---------------|----------------|-----------|------------|---------------|
| Deciduous tree.                 |                | cu curious.    | pr pretty.        | rk for rock-    | St striped.   | St straw.      | V violet. | Va varie-  | coloured.     |
| Evergreen.                      |                | cul culinary.  | work.             | ro robust.      | Su sulphur    | Tan tan-co-    | Ve vermi- |            |               |
| Palm tree.                      |                | de delicate.   | spl splendid.     | tm timber tree. | loured        | Taw tawny.     | Vy veiny. |            |               |
| Deciduous shrub.                |                | dy dyeing      | un uninteresting. | w weed, abund-  | Test testace- | Tran transpar- | W white   | Y yellow.  | Ysh yellowish |
| Evergreen shrub.                |                | plant.         | ec economical.    | dant in         | ous.          |                |           |            |               |
| Deciduous under-shrub.          |                | el elegant.    | esc esculent.     | cultivated      | ous.          |                |           |            |               |
| Evergreen under-shrub.          |                | fr fruit tree. | fra fragrant.     | soils in its    | ous.          |                |           |            |               |
| Deciduous twiner, ligneous      |                | gr grotesque.  | m medicinal.      | native          | ous.          |                |           |            |               |
| or herbaceous.                  |                | or ornamental. |                   | country.        |               |                |           |            |               |
| Evergreen twiner, lig. or       |                |                |                   |                 |               |                |           |            |               |
| herb.                           |                |                |                   |                 |               |                |           |            |               |
| Deciduous climber, lig. or      |                |                |                   |                 |               |                |           |            |               |
| herb.                           |                |                |                   |                 |               |                |           |            |               |
| Evergreen climber, lig. or      |                |                |                   |                 |               |                |           |            |               |
| herb.                           |                |                |                   |                 |               |                |           |            |               |
| Deciduous trailer, lig. or      |                |                |                   |                 |               |                |           |            |               |
| herb.                           |                |                |                   |                 |               |                |           |            |               |
| Evergreen trailer, lig. or      |                |                |                   |                 |               |                |           |            |               |
| herb.                           |                |                |                   |                 |               |                |           |            |               |
| Deciduous creeper, lig. or      |                |                |                   |                 |               |                |           |            |               |
| herb.                           |                |                |                   |                 |               |                |           |            |               |
| Evergreen creeper, lig. or      |                |                |                   |                 |               |                |           |            |               |
| herb.                           |                |                |                   |                 |               |                |           |            |               |
| Deciduous herbaceous plant.     |                |                |                   |                 |               |                |           |            |               |
| Evergreen herbaceous plant.     |                |                |                   |                 |               |                |           |            |               |
| Grass.                          |                |                |                   |                 |               |                |           |            |               |
| Bulbous plant.                  |                |                |                   |                 |               |                |           |            |               |
| Fusiform-rooted plant.          |                |                |                   |                 |               |                |           |            |               |
| Tuberous-rooted plant.          |                |                |                   |                 |               |                |           |            |               |
| Aquatic.                        |                |                |                   |                 |               |                |           |            |               |
| Epiphyte.                       |                |                |                   |                 |               |                |           |            |               |
| <i>Duration and Habitation.</i> |                |                |                   |                 |               |                |           |            |               |
| Perennial.                      |                |                |                   |                 |               |                |           |            |               |
| Biennial.                       |                |                |                   |                 |               |                |           |            |               |
| Annual.                         |                |                |                   |                 |               |                |           |            |               |
| Bark, or moist, stove.          |                |                |                   |                 |               |                |           |            |               |
| Dry stove.                      |                |                |                   |                 |               |                |           |            |               |
| Greenhouse.                     |                |                |                   |                 |               |                |           |            |               |
| Frame.                          |                |                |                   |                 |               |                |           |            |               |
| Bark stove perennial.           |                |                |                   |                 |               |                |           |            |               |
| Dry stove perennial.            |                |                |                   |                 |               |                |           |            |               |
| Greenhouse perennial.           |                |                |                   |                 |               |                |           |            |               |
| Frame perennial.                |                |                |                   |                 |               |                |           |            |               |
| Bark stove biennial.            |                |                |                   |                 |               |                |           |            |               |
| Dry stove biennial.             |                |                |                   |                 |               |                |           |            |               |
| Greenhouse biennial.            |                |                |                   |                 |               |                |           |            |               |
| Frame biennial.                 |                |                |                   |                 |               |                |           |            |               |
| Bark stove annual.              |                |                |                   |                 |               |                |           |            |               |
| Dry stove annual.               |                |                |                   |                 |               |                |           |            |               |
| Greenhouse annual.              |                |                |                   |                 |               |                |           |            |               |
| Frame annual.                   |                |                |                   |                 |               |                |           |            |               |
| <i>Popular Character.</i>       |                |                |                   |                 |               |                |           |            |               |
| ag agricultural.                | clt cultivated |                |                   |                 |               |                |           |            |               |
| cl clothing.                    | in its na-     |                |                   |                 |               |                |           |            |               |

### *Native Country.*

|           |                    |
|-----------|--------------------|
| C. G. H.  | Cape of Good Hope. |
| E. Ind.   | East Indies.       |
| N. Amer.  | North America.     |
| N. Eur.   | North of Europe.   |
| N. Holl.  | New Holland.       |
| N. S. W.  | New South Wales.   |
| S. Amer.  | South America.     |
| S. Eur.   | South of Europe.   |
| V. Di. L. | Van Diemen's Land. |
| W. Ind.   | West Indies.       |

### *Propagation.*

|    |                        |
|----|------------------------|
| B  | by budding.            |
| C  | cuttings.              |
| D  | division of the plant. |
| G  | grafting.              |
| I  | inarching.             |
| L  | layers.                |
| Ls | leaves.                |
| O  | offsets.               |
| R  | division of the root.  |
| S  | seeds.                 |
| Sk | suckers.               |

### *Soil.*

|        |                           |
|--------|---------------------------|
| aq.    | watery places.            |
| co.    | common garden soil.       |
| c.p.   | common peat or bog.       |
| h.     | heavy rich clay.          |
| h.l.   | heavy loam.               |
| l.     | loam.                     |
| l.p.   | loam and peat, most loam. |
| lt.    | light vegetable soil.     |
| lt.l.  | light loam.               |
| m.s.   | moist soil.               |
| p.     | peat.                     |
| p.l.   | peat and loam, most peat. |
| r.     | rich garden soil.         |
| r.m.   | rich mould.               |
| ru.    | rubbish.                  |
| s.     | sand.                     |
| s.l.   | sandy loam.               |
| s.p.   | sandy peat.               |
| s.p.l. | sand, peat, and loam.     |

The systematic names of plants are accented as in the *Hortus Britannicus*. The derivations of the genera are given, and the specific systematic names literally translated, any explanatory words accompanying such translation being printed in Italic. Those names, whether of genera or species, which are commemorative, as *Banksia* in honour of Sir Joseph Banks, are distinguished by having the subjoined letters in Italic where the rest of the word is in Roman, and in Roman where the rest of the word is in Italic, as *Banksia*; those which have been applied to plants by the classic writers of antiquity are distinguished by having the initial letter in Italic, as *Pyrus*, where the rest of the word is in Roman, and in Roman where the rest of the word is in Italic, as *Pyrus*. All words, generic or specific, of unknown derivation, or aboriginal names, are wholly in Italic or wholly in Roman, according to the letter in which the preceding or following matter may be printed, as *Pæderia Lingun Boj.*, or *Padèria Lingun Boj.*

---

THE

GARDENER'S  
MAGAZINE.

—  
CONDUCTED

By J. C. LOUDON.

—  
VOL. XVII.

1841.

THE

GARDENER'S  
MAGAZINE.

—  
CONDUCTED

By J. C. LOUDON.

—  
VOL. I.

Third Series.

1841.

THE

GARDENER'S  
MAGAZINE

FOR

**M DCCCXLI.**

—  
CONDUCTED

By J. C. LOUDON.

---

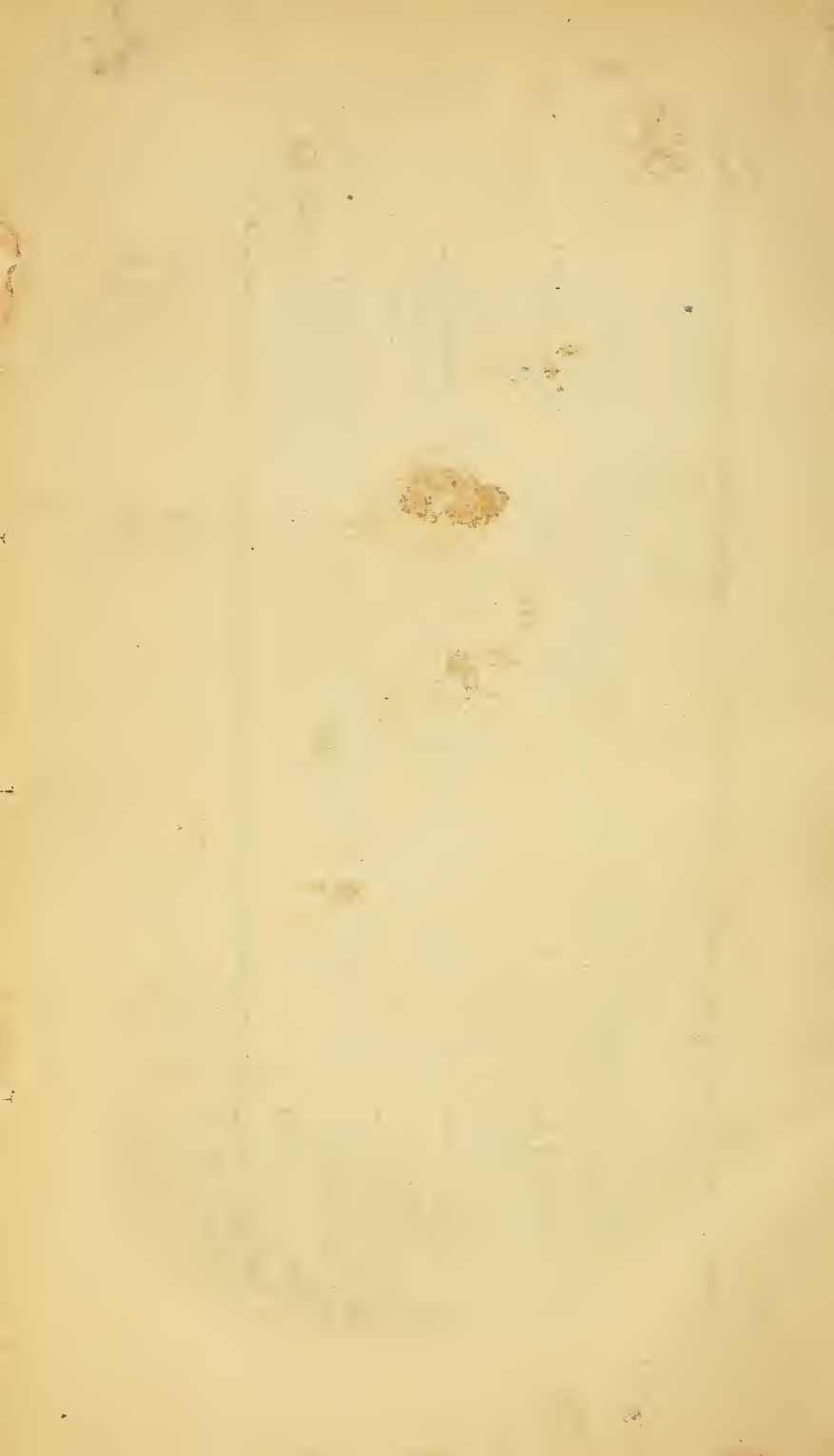

















SMITHSONIAN INSTITUTION LIBRARIES



3 9088 01527 8575