

TDK  
V283  
M

# MAKING THE SMALL SHOP PROFITABLE

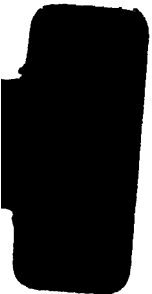

**Library**  
of the  
**University of Wisconsin**

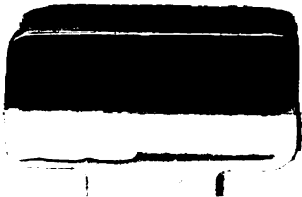

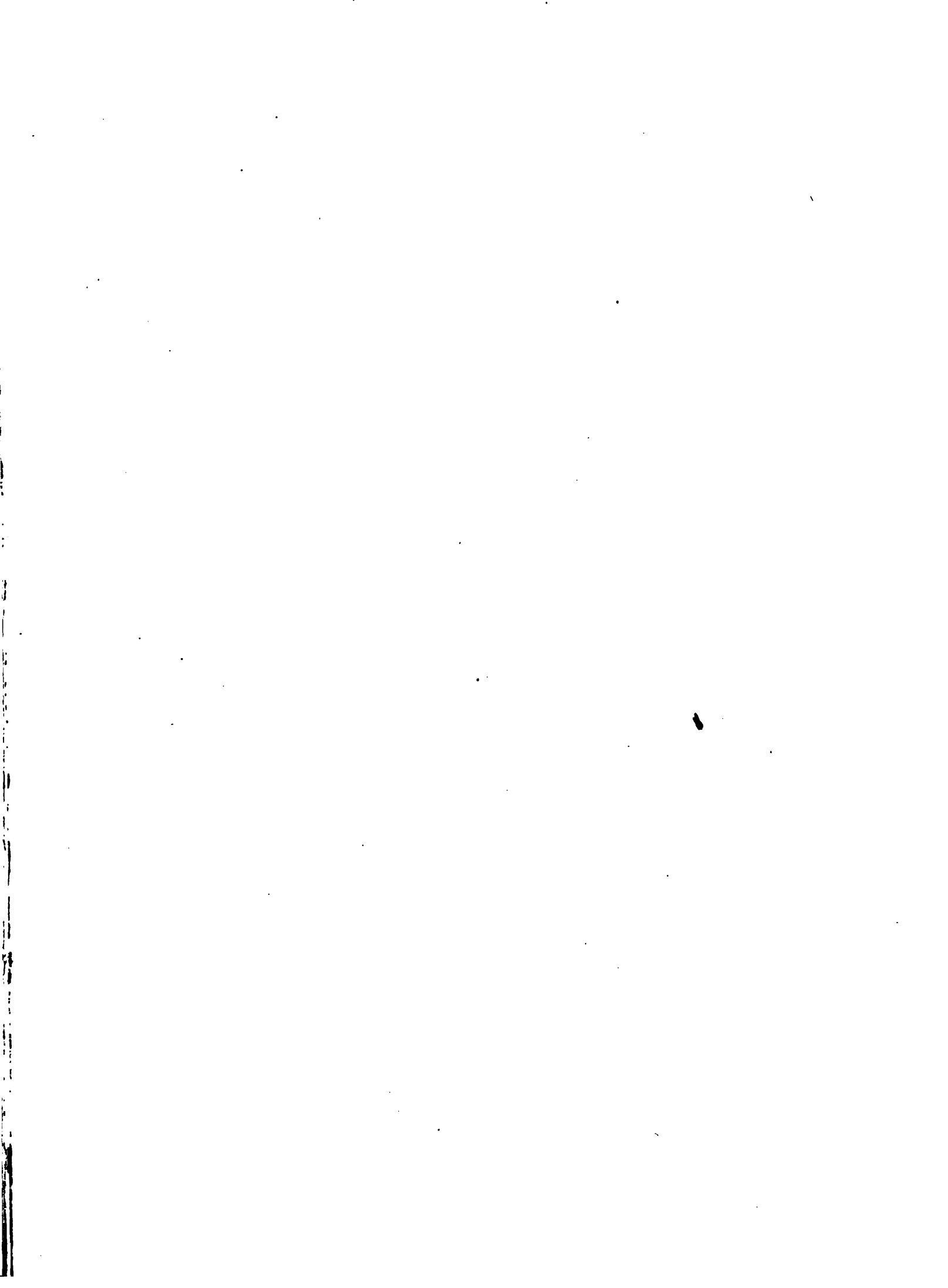



**Making the  
Small Shop Profitable**



# Making The Small Shop Profitable

By

**John H. Van Deventer, M.E., Memb. A.S.M.E.**

EDITOR-IN-CHIEF THE AMERICAN MACHINIST  
AUTHOR, "SUCCESS IN THE SMALL SHOP," "HANDBOOK OF MACHINE  
SHOP MANAGEMENT," CO-AUTHOR, "MANUFACTURE  
OF ARTILLERY AMMUNITION"

FIRST EDITION

PUBLISHED BY  
THE AMERICAN MACHINIST  
—  
MCGRAW-HILL BOOK COMPANY, INC.  
SOLE SELLING AGENTS  
239 WEST 39TH STREET, NEW YORK  
1918

COPYRIGHT, 1918, BY THE  
MCGRAW-HILL BOOK COMPANY, INC.



222408

JAN -7 1919

T D H

.V283

M

6934 786

## FOREWORD

For years the word "Small Shop" conveyed to one's mind the impression of hard work and no profits. The owner of a small shop was regarded with pity and looked upon as one having the responsibilities of a capitalist and the net income of a day laborer. Small shop ownership was a temporary affair and the sign painter made frequent visits to the same institution to change the name of the proprietor on the "shop shingle."

Now the small shop is recognized as an honorable and also a profitable institution.

The change itself and the recognition of the position of the small shop by the mechanical public has been materially helped and in fact largely effected by the *American Machinist's* "Small Shop Series" which was the first consistent attempt to help the small shop find itself and to help the mechanical public to find the small shop.

So effective was this series that after publication in the *American Machinist*, repeated demand made necessary the republication of these articles in book form. The first fifty articles were gathered together under the title of "Success in the Small Shop," of which successive editions have been printed in response to the demand of those interested in making small shops successful.

The present volume "Making the Small Shop Profitable" is a collection of the later writings of the same author on important phases of small shop activity. It contains also an illustrated encyclopedia of small shop methods or "kinks" which should prove of the utmost practical value to the mechanic whose means for doing work are restricted to what is ordinarily found in the small shop.

THE AUTHOR.

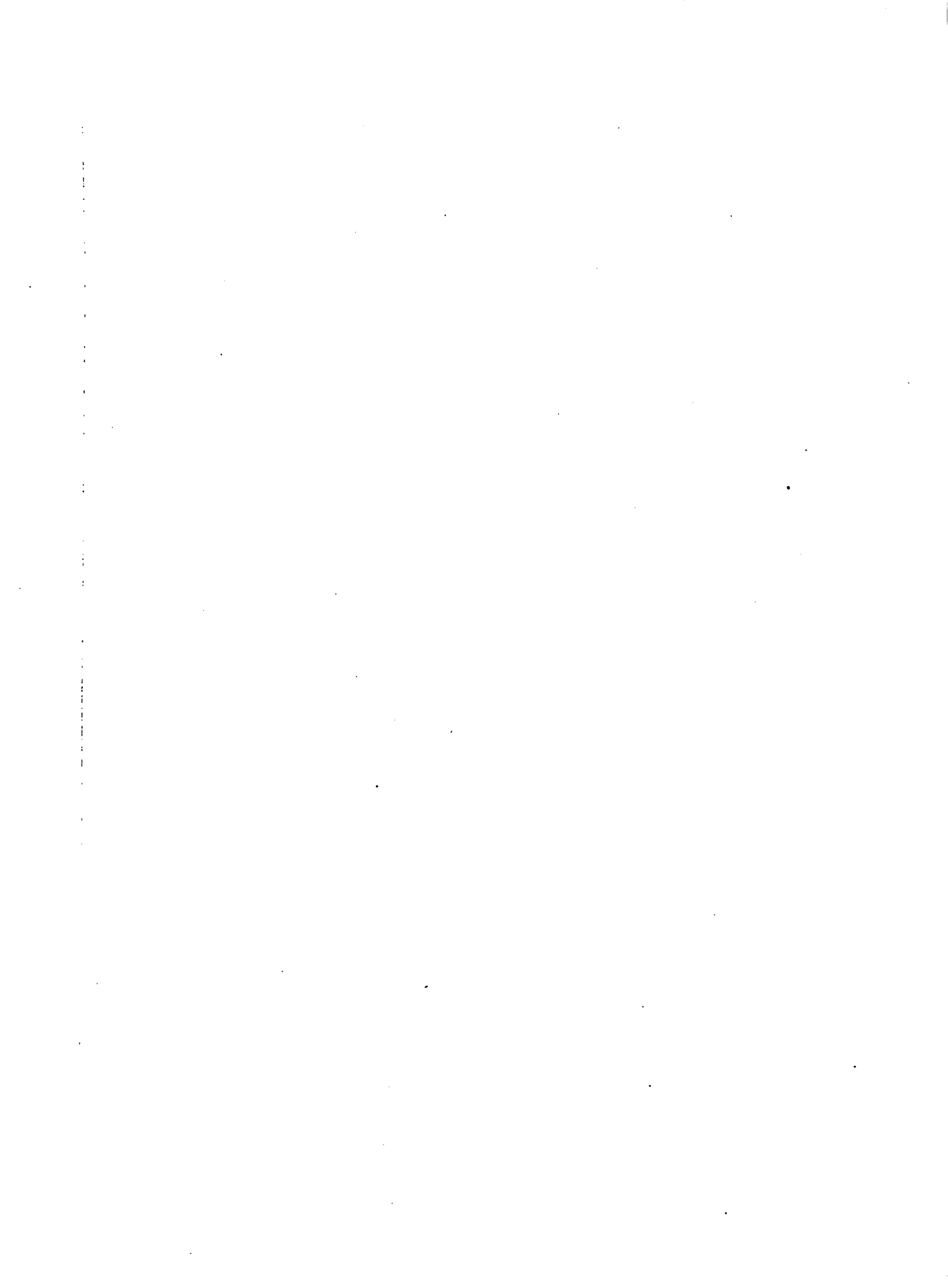

# CONTENTS

	PAGE
PREFACE . . . . .	v
GETTING "INTO" THE SMALL SHOP . . . . .	1
LIMITING IMPROVEMENTS IN THE SMALL SHOP . . . . .	3
USING SKILL FOR CAPITAL IN THE SMALL SHOP . . . . .	5
FINDING THE TURNING POINT IN THE SMALL SHOP . . . . .	7
WEIGHING PATTERNS AND CASTINGS BY DISPLACEMENT OF WATER . . . . .	9
SPRING FEVER IN THE SMALL SHOP . . . . .	10
MAKING PATTERNS AND CASTINGS FOR THE SMALL SHOP . . . . .	12
THE SMALL SHOP GRINDING WHEEL . . . . .	14
THE SMALL SHOP GRINDER . . . . .	17
A HANDY CLIP FOR HANGING WET BLUEPRINTS . . . . .	19
KNURLING IN THE SMALL SHOP . . . . .	20
SCREW THREADS IN THE SMALL SHOP . . . . .	25
MEASURING SCREW THREADS IN THE SMALL SHOP . . . . .	28
LIFTING THE SHAPER CHUCK . . . . .	30
HARDENING AND SOFTENING STEEL IN THE SMALL SHOP . . . . .	31
BORING PUMP CHAMBERS IN THE DRILLING MACHINE . . . . .	33
A HANDY DRIVER FOR REMOVING SHELL SOCKETS . . . . .	33
CARBONIZING SMALL SHOP STEELS . . . . .	34
CASEHARDING SMALL SHOP STEELS . . . . .	36
TAKING SMALL SHOP TEMPERATURE . . . . .	38
PAINTING SMALL SHOP PRODUCTS . . . . .	41
CARING FOR SMALL SHOP BEARINGS . . . . .	47
A BUILT UP LIMIT GAGE . . . . .	49
SPECIAL FORM OF HOLLOW MILL . . . . .	49
RADIUS PLANING TOOLS . . . . .	49
METHODS OF LOCATING MACHINERY FOUNDATION . . . . .	50
END MILL FOR BABBITT . . . . .	52
STANDARDISING SHOP DRAWINGS FOR MACHINE DETAILS . . . . .	53
LUBRICATING OILS AND CUTTING COMPOUNDS FOR SHOP USE . . . . .	56
PREVENTING LORAL SHRINKAGE IN ALUMINUM CASTING . . . . .	61
ADJUSTABLE DRIVE . . . . .	61
BENCH, VISE AND ASSEMBLING METHODS . . . . .	62
DEVICES THAT MAKE LATHES PROFITABLE . . . . .	63
MONEY SAVING ASSEMBLING METHODS . . . . .	64
PROFIT MAKING DEVICES FOR TURNING . . . . .	65
BORING AND TURNING KINKS . . . . .	66
A VARIETY OF TIME SAVING KINKS . . . . .	67

## CONTENTS

	PAGE
A NUMBER OF IDEAS FOR PLANERS . . . . .	68
GRIPPING AND HANDLING KINKS . . . . .	69
CHUCKS AND TURNING . . . . .	70
HANDY KINKS FOR THE HANDY MAN . . . . .	71
HELPING THE DRILLING MACHINE TO EARN A PROFIT . . . . .	72
VARIOUS LOCKNUT AND LOCKING DEVICES . . . . .	74
SIX HELPS FOR THE SMALL SHOP LATHE . . . . .	78
CONVENIENT KINKS FOR THE SMALL SHOP ASSEMBLER . . . . .	79
SOME USEFUL PLANER KINKS . . . . .	80
A VARIETY OF EXPANDING ARBORS . . . . .	81
IDEAS FOR THE SMALL SHOP BLACKSMITH . . . . .	82
PLANER AND SHAPER DEVICES THAT SAVE MONEY . . . . .	84
A COLLECTION OF BELT CUTTING DEVICES . . . . .	85
A NUMBER OF WAYS TO CUT PINS IN QUANTITIES . . . . .	86
SPRING WINDING AND CUTTING . . . . .	87
VARIOUS METHODS OF DRIVING AND PULLING BUSHINGS . . . . .	88
MAKING THE DRILLING MACHINE EARN DIVIDENDS . . . . .	90
BENCH AND VISE KINKS OF SHOP VALUE . . . . .	91
STUNTS THAT MAKE SHAPERS EARN PROFITS AND PAY DIVIDENDS . . . . .	92
A COLLECTION OF BENCH AND VISE KINKS . . . . .	93
SLIDE REST KINKS AND CUTTING TOOL STUNTS . . . . .	94
HINTS THAT WILL HELP THE EFFICIENT LATHE HAND . . . . .	95
GEAR DENTISTRY AND OTHER KINKS . . . . .	96
SEVEN APPLICATIONS OF "OLD MEN" . . . . .	97
VARIOUS WAYS OF PULLING KEYS . . . . .	99
WORK BENCH AND OTHER KINKS . . . . .	100
MORE VISE KINKS . . . . .	102
KNEE AND FOOT OPERATING DEVICES FOR THE BENCH . . . . .	103
CLAMPING AND HOLDING MATERIAL IN VISES . . . . .	104
USEFUL DEVICES FOR THE SHOP . . . . .	105
HAND WHEEL SPANNERS AND OTHER KINKS . . . . .	106
VARIOUS TYPES OF JACKS AND CLAMPS . . . . .	107
INTERNAL, EXTERNAL AND END LAPPING DEVICES . . . . .	108
ROUGH INTERNAL LAPPING DEVICES . . . . .	109
DIFFERENT TYPES OF PIPE HANGERS . . . . .	110
INDEX . . . . .	111

# Getting "Into" the Small Shop

BY JOHN H. VAN DEVENTER

---

*SYNOPSIS*—Some customers have developed highly efficient ways of working up a fictitious credit, with the object of "putting one over" on the small shop when the time is ripe. This article relates one such instance, which had the effect of closing the doors of a small marine repair shop. Incidentally it introduces the reader to Dave Hope, the Knight-Errant Machinist.

---

"Rivet a washer on the end of your cold chisel, Sonny!"

Dave Hope addressed this bit of advice to the new apprentice, whose hand was swollen to twice its natural size as the result of well-intentioned but misaimed hammer blows. The lad has passed the stage of looking for left-hand monkey-wrenches and of being sent from machine to machine in search for the key of the big planer, and was now learning the rudiments of chipping. Dave Hope's repair shop was a good place in which to learn this art, for there were plenty of castings to chip, and hardly any two of them were alike. Incidentally it was a great privilege for a boy to learn his trade in Dave's shop, for its owner was a real "all around" machinist, and an apprentice trained by him was able to use both head and hands when he stepped out of his time.

It will not be amiss to introduce Dave to you with a description of the man and a brief outline of his checkered career, for it is my hope to be able to recount from time to time during the year some of the most interesting of his adventures in small shops. Please overlook the single grimy finger that he extends you in greeting, and grasp him by the hand, for I know that *American Machinist* readers will not hesitate because of the signs of honest toil that are upon it.

Dave is one of those men whose age it is hard to tell from his appearance. The youthful expression of his face seems to contradict the evidence presented by his white hair and mustache, and his tall, somewhat spare figure is as active as that of a man of 30. He started to serve his time in a railroad repair shop when a boy of 12, in the days when a railroad-shop apprenticeship meant a much more varied experience than it does at present. A few years of knocking about the country followed this, during which he carefully avoided the big "manufacturing shops," for Dave, as he says himself, "never did have a liking for doing the same thing twice."

## DAVE HOPE, THE KNIGHT-ERRANT MACHINIST

One fairly large repair shop in the West Virginia coal fields held him for 18 months—not because Dave was beginning to settle down, but because he had a good paying job as foreman, and board was cheap. He was beginning to get the "shop of his own" idea, and this seemed like a good chance to get the necessary money to start with. It was while here that Dave Hope's hair turned gray, due to being caught by a "fall" while directing the installation of a receiver on an air line in the lower level. Three days in darkness after the safety lamps burned out left their physical effect upon him, but seemed to make no impression on his spirit; or if any, it was to strengthen his disregard of danger or obstacles standing in the way.

Then began his adventures with small shops of his own—many of them, but one shop at a time—most of them disastrous financially, for Dave is no "captain of industry," but rather a "knight-errant machinist" who loves to venture where those seeking more substantial return fear to tread. And while he has attended the obsequies of more defunct plants than any other man of my acquaintance, the funeral services are scarcely over before you find Dave installed in another shop in which he does what he pleases in the way that suits him best. While these many changes have kept him rather poor in pocket, they have made him rich in experience and character, and as a curious result he has a sort of camp following among those who work for him. Thus as I leaned against the bench and heard him deliver the foregoing words of advice to the apprentice, I could pick out among those working about the shop, faces which I had seen both in his shop in Philadelphia and in the one in Kansas City, where our acquaintance began.

## THE KIND OF EXPERIENCE THAT STICKS

"That kid with the sore thumb is getting experience," remarked Dave. "We all get it that way, and it's the only way that seems to stick. Life is a series of bumps from the time you slide off the first step till you hit the bottom landing. It's all in getting used to it. You can even get so you like it, as the boy did who had the measles three times. Sometimes it's a money loss, sometimes a machine won't work as you expect, and sometimes a disappointment in human nature. The hardest kind of a bump is when a man you trust goes back on you. I've had a number of such experiences, and while I can look back now and see the funny side of them, the sore spot lasted much longer than it did with the ordinary kind of bumps.

"Maybe it will interest your readers to hear of a lesson I learned about extending credit. I hope other small-shop owners may profit by it, and that it will help some of them to avoid paying the price that I did for this kind of experience.

"If you've been along Long Island Sound during the summer season, you've noticed what a slew of motor boats and steam yachts there are dotting the bays outside of the summer-resort towns. I noticed this about nine years ago, and also that about five boat owners out of seven seemed to have trouble with their motors when they got 50 ft. away from the dock. Of course this wasn't to be wondered at. Many of the owners were clerks from the city who knew as much about taking care of an engine as that green apprentice boy does about swinging a hammer. The boats were mostly hand-me-downs; not merely second hand, but seventh or eighth hand, and in addition the gasoline that those alongshore dealers worked off on that bunch of innocents was so weak that it could hardly run even when the can was turned upside down.

"I didn't have a shop just at that time, and the idea struck me that here was an opportunity that a good mechanic might turn to advantage. This was before the automobile became common, remember, and there were not many machinists in those days who understood the

## MAKING SMALL SHOPS PROFITABLE

kinks and troubles of small gasoline motors. At least those that I found in the existing shops along the waterfront didn't know much about them, judging by the work they turned out.

"After looking about for a week or so, I ran across a place that looked good to me. The shop stood up on posts at the water's edge and had a dock of its own. The equipment was nothing to brag about, consisting of two lathes in fair condition, one of 16-in. and one of 18-in. swing, a more or less dilapidated gap lathe built up to swing 48 in., a shaper that had seen better days, a pipe threader and two upright drills. I guess what really attracted me to the place more than anything else was seeing a small boy catch three fine flounders in quick succession from the end of the dock. It looked to me like a good place for a fisherman to locate!

"It was about the middle of June that I came into possession. I managed to get enough cash together to make a satisfactory first payment and started in to get some of the money back. Reddy Burke, that you see over there on the miller, was with me, and so was Sandy McPherson, the fellow with his back turned to us, who is fitting a key at that bench. People were just getting their boats out and a quite a bit of overhauling was to be done. A good many of them came to us because they knew we couldn't do any worse by them than the other shops and might possibly do better.

"At first most of the work was on small motors, one and two cylinders, ranging from 4 to 20 hp. We turned out good work on these, and the reputation brought us some of the larger boats and a better grade of work along with it. There was one boat that we couldn't touch. It was the largest craft that anchored at the port, a 90-ft. steam yacht with twin triple engines. It seems that in this world what you can't get is what you want most, and it bothered us a lot to see the work on that boat go to a fellow a quarter mile up the bay, especially as we knew what sort of mechanic he was. The 'Alice,' that was her name, made regular trips across the sound and carried passengers back and forth from the shore resorts on each side.

### ALICE, WHERE ART THOU?

"Business went up pretty good, and by the end of July we had taken in enough over and above expenses to make the second payment on the shop. At this rate we would be clear before the end of the season. Any reasonable man ought to have been satisfied with that, but in spite of it our fingers itched to get hold of the 'Alice' and get a chance at work that was really worth while.

"One afternoon about four, we were all busy in the shop when somebody hailed from the end of the dock. I started out to find what was wanted and saw a short stout fellow climbing out of a dinghy that was tied to one of the spiles at the landing platform. When I got a look at his face I saw that he was Captain Skinner of the 'Alice.'

"'Anybody here that understands high-pressure feed pumps?' he asked.

"It took me about two minutes to explain to the captain that there were three men in our shop who knew more about high-pressure feed pumps than any six that he could find if he offered a reward for them anywhere in the United States. I don't know whether he believed

it or not, but he was up against it, so Sandy went out in the dinghy, taking his tool kit with him.

"He turned up again in an hour and a half with some samples of mush that had clogged up the discharge check valve and prevented the pump from doing its work. 'Nothing the matter with the pumps,' said Sandy. 'The trouble was with the last butcher that overhauled it and put in cold-water packing!'

"Captain Skinner came to us to have his work done after that, and while all the jobs were small ones, it made us feel pretty good to think that the 'Alice' had had to come to Hope's Marine Repair Shop at last. Nobody could have been any better pay than the captain; he never questioned a bill and settled each one within ten days.

"After the middle of August, work slackened up a bit. Most of the boats would be put up after Labor Day, and the owners were beginning to cut down expenses and get along with motors that would run at all, just as nowadays you see a fine lot of decrepit auto tires displayed in the fall. We hadn't figured on this, and it hurt us more than I cared to admit.

### A JOB THAT LOOKED LIKE A LIFE-SAVER

"It looked like a life-saver when, the day after Labor Day, Captain Skinner turned up with a three-weeks' job for us on the 'Alice'—nothing less than a complete overhauling of the twin triple engines and all of the auxiliaries. The three of us moved over to the 'Alice' next day with our tool kits, and settled down to three weeks of the hardest work we ever did. All of us had corns on our backs from working in the engine pit.

"At the start of the third week Captain Skinner asked me to try to finish up by the coming Saturday morning. As there was some work waiting for us at the shop, we decided to work overtime nights so as to be sure to clean up by Friday night. By Thursday noon we saw that we would finish within the limit, but we were all three so tired out and short-tempered that we had to invent new cuss words to pay our respects to each other, having exhausted all of the ordinary ones.

"Friday night we turned her over to the captain, everything shipshape and better than new. I figured that there was close to a thousand dollars' worth of time and material on that job, and it was worth every penny of it. The captain wanted to give her a trial spin Saturday morning and insisted that I go along with him to see that everything was all right; but in view of all of the work waiting at the shop this was impossible, so I told him to try her out with his own crew. I was sure of the job and knew it would be all right. I handed him the bill for the work, and he said he would settle next evening if nothing went wrong.

"We went to work at 6 o'clock next morning to catch up with the accumulated work. At 8 o'clock one of the boys looked out of the window and said that steam was up on the 'Alice.' At 8:30 she began to move, and we all rushed to the window to give her a wave for good luck. On she went down the bay toward the outlet, looking as pretty as a picture and making a good two knots more than she had been capable of before we overhauled her. She rounded the headland, and we went back to work feeling that we had done a good job.

"We had; but so had Captain Skinner, for that was the last we ever saw of the 'Alice'!"

# Limiting Improvements in the Small Shop

BY JOHN H. VAN DEVENTER

---

*SYNOPSIS*—Dave Hope tells of the small-shop experiences of two of his acquaintances. One of them was a "stick-in-the-mud" who became a Captain of Industry; the other, a brilliant but erratic individual, finished up as he began—in a nut factory. This article explains why some of us are not millionaires.

---

"No, sir! It's a very promising machine, but I don't want to make it."

Dave Hope was delivering this ultimatum to a young mechanic and inventor who had worked out an ingenious device and wanted Dave to manufacture it. The lad had brought for inspection a working model that was beautifully finished and that went through its motions in such an unusual yet precise way that no real mechanic could have examined it without being interested. In fact, the interest that Dave had displayed and the way that he had fingered the model had raised the inventor's hopes to a high point, and his keen disappointment at the final decision was evident.

"I'm too much of a mechanic to manufacture a machine of that kind, or in fact to manufacture anything at all," said Dave, taking note of the young man's feelings. "That is why I stick to contract work and to making experimental machines to order. No machine that I could manufacture would ever suit me, and I should be adding and improving all the time, which would be fatal to the finances."

"If a good mechanic won't manufacture a good machine, who is a fellow to go to?" asked the inventor despondently, reaching for his model.

"Wait a bit—don't go yet," said Dave. "I want to tell you about Jones and Jenks; perhaps it may help to answer your question."

## ALBERT JONES, THE NATURAL IMPROVER

"Albert Jones was one of the smartest mechanics that ever lived. It came natural to him to improve things, and when he was in a shop he was always suggesting better ways of doing things. At night he'd spend his spare time thinking up new machines and making sketches of them, just for fun, throwing them away after they were all completed.

"Al got a job as 'improver' in a big shop. He was right at home at this work and made himself valuable. One day, perhaps, he'd be figuring a new way to chuck pistons and the next be sketching up an attachment to convert a drilling machine into a die sinker. Variety was his spice of life, and he never had to do the same thing twice.

"A man who lived as quietly and got as good pay as Al did couldn't help but save money, and after a few years he had a lump salted away so big that it bothered him to decide what he ought to do with it. Finally, he concluded to open a shop of his own and start manufacturing.

"The day after he had arrived at this decision he was called into the blacksmith department to scheme some way of keeping nuts from bouncing off the helve-hammer bolts and to prevent the bolts themselves from breaking. He sat up until 3 a. m. the next morning, scheming and sketching and scratching his head, and finally invented a shock-absorbing locknut. The following day he quit his job and filed a patent application.

"That locknut was the best thing of its kind that ever was. It would hang on like a suffragette, and its shock-absorbing qualities were without equal. A mighty good thing to start a manufacturing business on, was that nut, because it could be made in three operations by the crudest kind of help and sold for a price that was an inducement, even if it hadn't had such good qualities besides.

## AL GETS BUSY WITH PATENT LOCK NUTS

"Al had his plant going two months before the patent was issued and was forced to add a couple of men every week to keep up with the demand of a public that was hungry for shock-absorbing locknuts. In six months he had designed and built special machines that would turn the nuts out almost as fast as a boy could carry them away. Things looked very rosy indeed for Al—to an outsider.

"There was one big defect in it from his point of view—the thing couldn't be improved upon. It was so simple and perfect that nothing in that line could be any better. An ordinary man would have been very well pleased at such a state of things, but not Al. All of the inventiveness and ingenuity in his system was corked up, so to speak, and was building up a pressure that was bound in time to blow the cork out—that cork being the shock-absorbing locknut! He began to detest the sight of one. 'Why should a man with brains tie himself up for life to a dinky one-piece contraption like that?' he would ask himself. Then he would lay off for the rest of the day, go back to his room, put his stocking-clad feet on the radiator and dream of complicated mechanical stunts that would make an ordinary man dizzy to think about.

## WILLIAM JENKS PARTS WITH TEN THOUSAND PLUNKS

"Al was a man who had to act quickly when an idea struck him, so he sold out his shock-absorbing nut business to a boob by the name of William Jenks, who had as much inventive ingenuity as an Eskimo's totem pole, but who seemed perfectly satisfied to give \$10,000 for a business worth five times as much. Then our inventive friend turned himself loose again like a colt in a pasture and began to put lines on paper and take a fresh interest in life.

"The result of his mental cyclone was a patented adjustable universal reamer that had a range of something like an inch in diameter for one tool as against the ordinary range of adjustment which begins with a decimal point followed by a naught. Where the locknut had been but a one-piece article, this tool had 27 parts, not

## MAKING SMALL SHOPS PROFITABLE

counting the screws, and therefore looked 37 times as good to Al, who saw plenty of opportunity for improvements and evenings filled with enjoyable mechanical meditation.

"It took considerably longer to put the reamer on a paying-basis than it had to make a go of the locknut. In fact, it cost Al so much money to start things and improve them a bit that he was forced to take in a partner—a mean man of money without high mechanical ideals, whose motto was, 'Let well enough alone!' Of course, Al couldn't work in harmony with a dub of this kind, so in a year he sold his interest to the dub for \$5,000 and breathed freely once more.

### A VERTICAL LATHE FOR SHAFT TURNING

"The next venture of friend Al was a duplex lathe that would turn two shafts at once and which, to save room, stood in a vertical position instead of horizontal. Al said that, while there were a number of vertical machines for chuck work, the vertical center-work field needed considerable improving. He produced a design that had several original features, one of them being the feed screw that was exactly in the center of the tool carriage, this latter sliding within the body of the lathe, a pair of headstocks and tailstocks being arranged on each side. He had quite a bit of fun improving this machine, especially in getting oil to stay in the vertical headstock bearings. By the time the sheriff came to the rescue and the last balance sheet was struck, Al came away with \$2,500 and a sense of relief at the prospect of tackling something new.

"One of his friends told him that if he wanted a chance to let loose the full power of his wonderful improving ability he should get into the automatic game, where there was a chance to pull off something big. This sounded pretty good to Al; but \$2,500 wasn't enough to break into the automatic game with, so he decided not to manufacture the machine, but to design one and get somebody else to build it.

"He had considerable trouble with his landlady, who insisted on getting into his room once a week to pick the papers off the floor, she being afraid to let them accumulate for a longer time than that because of the fire-insurance policy. This upset the inventing process badly, Al needing one or two days after each weekly clean-up to get the papers back on the floor again in their proper order. In spite of this, after a year of scheming and scratching he had an automatic machine that had more improved features than anything made before. It wasn't hard to get a patent on such an original batch of improvements, and a few months later, armed with official documents from Washington, Al started out to find a builder.

### FINDING A BUILDER FOR THE SUPERAUTOMATIC

"He called on a man in the automatic business and explained in detail how superior the Jones superautomatic was to the machine produced by the company. He not only told it, but proved it, convincing the engineers and experts who were called in to examine the plans. Evidently, the Jones superautomatic would be a clean sweep! Al was told to leave his plans and to call again in a week.

"He was received very cordially by the president. 'My dear Mr. Jones,' said this gentleman, 'we will offer you an exceptional contract for your invention. We wish the exclusive right to this and all improvements that you may make and in return will pay you a royalty of \$500 per machine. At this extraordinary figure we will expect you to act as consulting engineer and give a portion of your time to improving this device. Sign here on the bottom line!'

"I hardly need to say that Al signed. The president's words about 'improving' were even a stronger inducement than the \$500 per.

"For several weeks the inventor of the Jones super-automatic lived in the clouds. He worked out all sorts of further improvements and turned them over to the company, which seemed to be rather slow in getting started on the first machine.

"After six months passed in the same way, our friend began to be worried, especially as he was no longer admitted to the plant. He lay in wait for the president one day and accused him of not living up to his contract. 'My man,' said this individual, 'go back and read your contract. We agreed to give you a royalty of \$500 for each machine built and so far have lived up to your agreement absolutely.'

"What the president of the company had really done was to get Al out of the automatic field, where he would have been a dangerous man. His endless improvements would have kept things in an everlasting state of change, just as the man who finds out how to turn lead into gold will make a lot of trouble for everybody, including himself.

### AL JONES GETS A GOVERNMENT POSITION

"The last I heard of Al Jones was that he had a Government position with board and lodging, but no pay. He was engaged in making chalk marks on the floor of the harmless ward; and when a visitor to the asylum asked him what he was drawing, he'd say it was an improved automatic automatic-machine-making machine!

"As time went on, the asylum got to be overcrowded and a new building badly needed. Nothing could be done by the state, however, owing to the high cost of legislators, and it remained for a public-spirited Captain of Industry to donate two or three millions for the purpose. Rather a coincidence it was that this money to build a home for harmless nuts should have come from manufacturing shock-absorbing locknuts! But then William Jenks, who gave it, although a boob, was a good-hearted sort of chap."

Dave paused a moment and then continued with specific advice to the young inventor. "Now, if you want to make a success of your machine, find some man with money, but without ideas, to get back of it and push it."

## An Ounce of Invention

The average small shop with the average invention is a case of gamble pure and simple, with the odds 99 to 1 against success. No doubt about this at all for far less than 1 patent in 100 is successful. If you regard your small shop as an investment and run it as such, steer clear of the patent game until you have salted away enough to provide a distinct "experimental fund" that you can afford to lose.



# Using Skill for Capital in the Small Shop

By JOHN H. VAN DEVENTER

*SYNOPSIS—Doing what other people cannot do is one of the surest ways to success in the small-shop field. This article tells of a New England die-sinking shop that is making good on a line of work that requires a high degree of skill. How large-shop experience helps the small-shop owner to operate on sound and systematic lines becomes evident.*

When you go into a successful small shop, you are often struck with the resemblance it has to a well-managed department of a large shop. Evidently there are certain earmarks of good practice that apply to small and large

ing obtained his education in an institution richly enough endowed to be able to find better ways of doing things by experimentation, as distinguished from the small-shop man "brung up" in the small shop, who must cut his eye teeth without the aid of a dentist. And so when the ex-large-shop man starts a small shop he is apt to carry in his mind the memory of the large-shop department and its way of doing business.

The large-shop idea is evident in the small shop of Hollander & Johnson, Worcester, Mass., who specialize in drop-forge die sinking. At present some seventeen men are employed in this shop, which is a rather rapid growth from a two-man beginning made three years ago. To some extent the demand for drop-forge dies for munition mak-

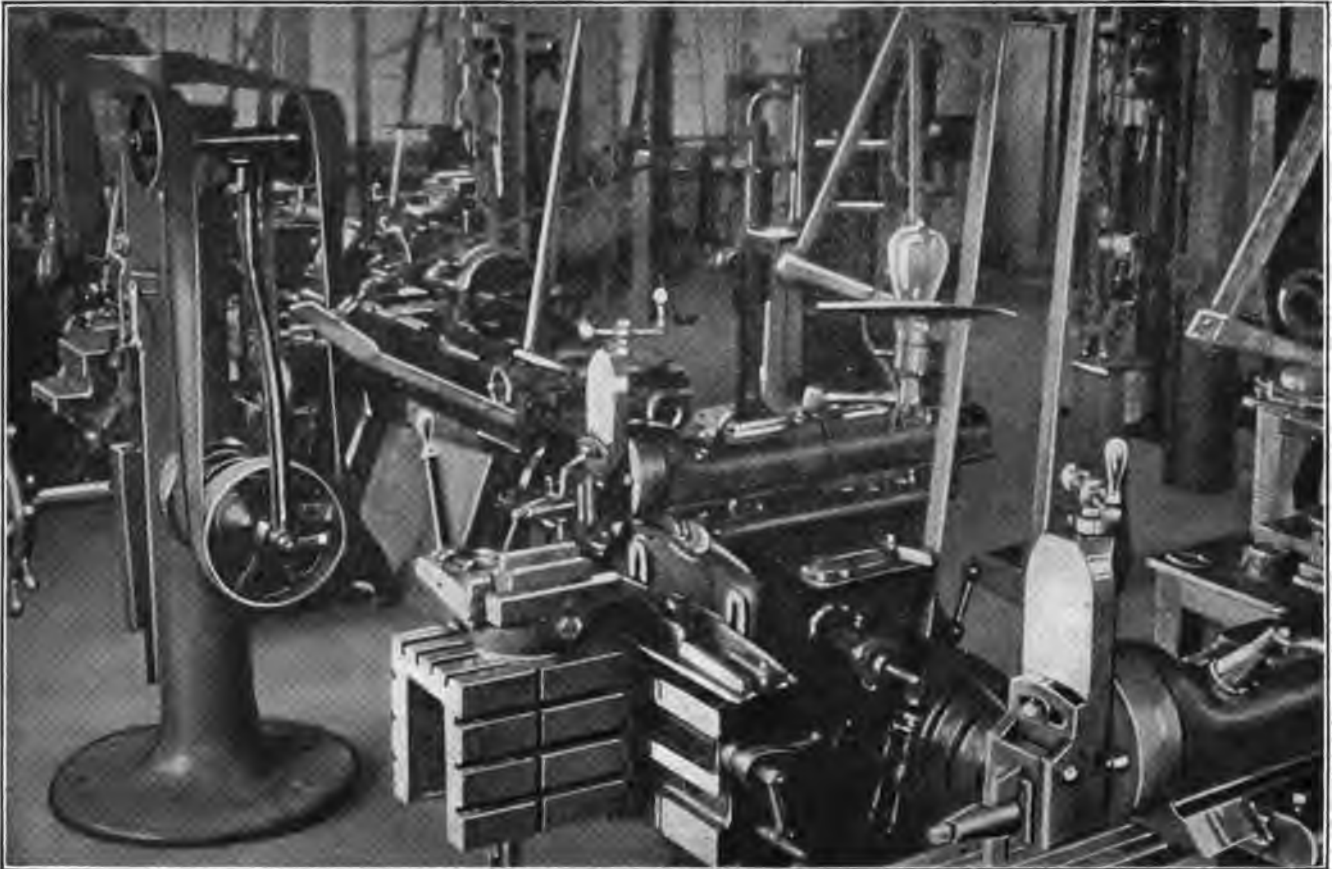

FIG. 1. A THREE-YEAR-OLD DIE-SINKING SHOP

shops alike. Some of them, such as a clean floor, orderly and convenient arrangement of machines, proper cupboards for small equipment and tools, may be classified, inventoried and written down in plain figures; others are more vague and elusive, but can nevertheless be quite plainly felt by a shopman's sixth sense. Among these is the perception that the work is being handled to advantage, from both the customer's and the shop owner's viewpoints. Time study would paint this picture after a month or two—the sixth sense will do it instantaneously, like a "snapshot" photograph.

The small-shop owner who has had a part of his training in a large shop is somewhat ahead of the game, hav-

ing has been responsible for this enlargement; but the start in the right direction was independent of this condition, and it is the start that will interest other small shops having a large capital of skill and a small capital of cash.

A shop struggling for a start cannot pick and choose the class of work that it does. Often the crucial test comes in the shape of an order for work that is apparently unsuited to the machine tools at hand. In this case it was an order for 450 sets of molds for making rubber shoe-soles. There were two machines available for this work—a shaper and a die sinker—in fact, with the addition of a lathe they comprised the entire shop equipment. Taking

## MAKING SMALL SHOPS PROFITABLE

the order for these 450 molds for delivery in 6 weeks took both nerve and hard work; but the task was accomplished by operating night and day, and doing it put the small shop on its feet—one might say a pair of rubber-soled ones!

S. G. Hollander obtained his large-shop experience in drop-forge dies at the United Shoe Machinery Co.'s plant



FIG. 2. SINKING RIFLE BOLT DIES

at Beverly, Mass., where he had charge of this class of work, both as to making the dies and using them. He has retained one very important large-shop feature in the making of such things—the division of labor according to the degree of skill required. Some small die-making shops are run on the old toolroom basis, one skilled man traveling about from machine to machine and taking care of the job from start to finish. The large-shop method is to pass the work from one man to another, each one a specialist on his own machine or bench, and this scheme is applied in the small shop to good advantage in both time and money.

The properly run small shop can take work requiring a high grade of skill at very nearly the cost-to-make in

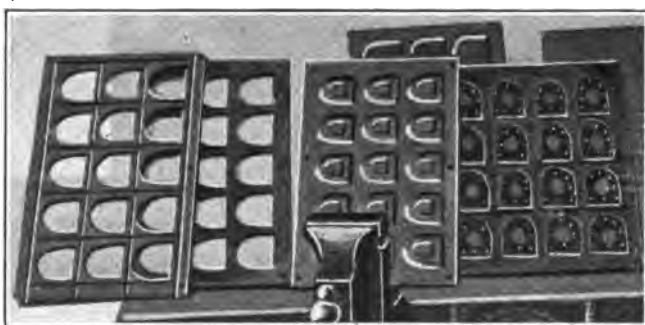

FIG. 3. MOLDS FOR MAKING RUBBER HEELS

the big-shop toolroom and come out with a profit. Here lies one of the big weapons of the small shop in hunting for business, and it is due to the low overhead expense as compared with the high one in the big plant. A shop of fifteen to twenty men, in which the owner is superintendent and manager, correspondent and time clerk, as well as on frequent occasions a die maker or tool maker, will show

up an overhead of from 15 to 25 per cent., as compared with the 100 to 150 per cent. of the big shop. If this fact is thoroughly mastered, it will open up new business for the small-shop man who grasps it and uses it as a selling argument.

Another feature that will result in business is to relieve the large shop of responsibility and detail. Some people cannot get enough responsibility to suit them, but the real big fellows have a habit of placing it on other

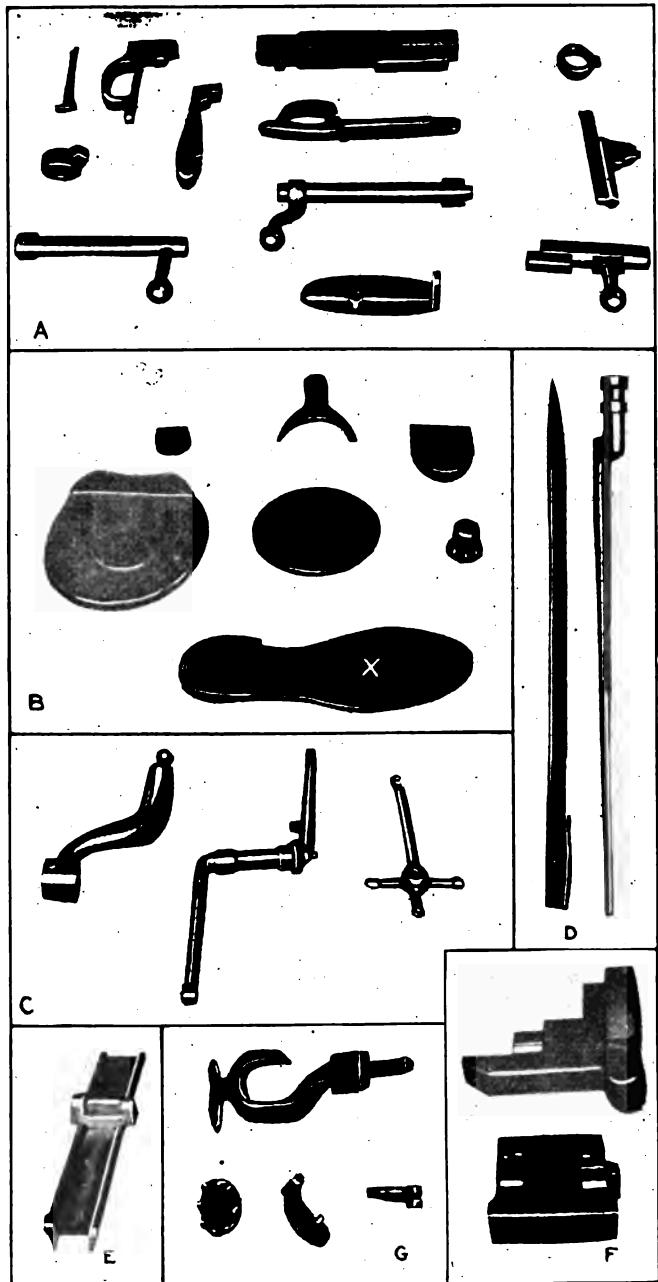

FIG. 4. ARTICLES PRODUCED IN SMALL-SHOP MADE DIES  
A—Military rifle forgings; B—Rubber die products; C—Auto and bicycle forgings; D—Bayonet forgings; E and F—Machine-gun forgings; G—Miscellaneous.

shoulders than their own when they make sure that these shoulders are broad enough to carry it. The small-shop man with small views is apt to pin the responsibility as closely to his customer as he can, living up strictly to his blueprint. The small-shop man with big views goes at it another way, saying: "Show me the piece you want made and the machine on which you want to make it and leave the rest to me. I will be responsible for the result."

# Finding the Turning Point in the Small Shop

BY JOHN H. VAN DEVENTER

*SYNOPSIS—In the majority of successful shops there is one definite turning point at which a start is made toward bigger and better business. Many times this change is made unconsciously, and the turning point cannot be definitely located. In this case the installation of one machine changed the shop product from an average to an exceptional one.*

A small shop that is 68 years old is something of a rarity and is therefore of interest in a country where plants mushroom over night as if under the spell of Aladdin's lamp. That a small shop can stand the buffings and trials of 68 years of competition is also an interesting fact, establishing as it does that the small shop is after all of a hardy and robust nature. In an



FIG. 1. THE LABORATORY OF A SMALL SHOP THAT SPECIALIZES IN HIGH-SPEED STEEL

instance of this kind, one is apt to look for work a little out of the ordinary in order to account for such a long existence.

Knife grinding in the old days before the advent of the surface grinder and the magnetic chuck was an operation in which the old-fashioned grindstone and sidewheel labored in partnership with a patient grinder hand who was unable with all his skill to grind anything really straight. Fifteen-thousandths of an inch was considered a close job in those days. Most of the work was held and fed by hand, some of it in crude fixtures that were as likely to spring the knife out of shape as to hold it flat. Only those who have surface-ground thin stock by such means in the past can appreciate the real value of the magnetic chuck.

Prior to 1906 this was the way that A. Hankey & Co., Rochdale, Mass., were grinding knives. A rather ordinary line of work, one might say, and one that was not at all uncommon throughout New England, where knife grinding in America was indigenous.

A shop, in order to keep up with the times, must not only study its own progress and that of its competitors, but—and more important—it must keep in close touch

with the progress and tendencies of its customers. Shops exist that are so bound up in themselves that self-interest is a far bigger factor than service, and other shops depending on these for a part of their products oftentimes find their own advancement hindered through a lack of someone's else initiative. At the time of which I have been speaking, when knife grinding was so crudely handled, a class of knife users of considerable importance consisted of the woodworking-machinery manufacturers. Compared with the present-day product, wood planers at this time were crude and slow machines. A feed of 25 ft. per min. was considered high and in fact was about the maximum that could be used for smooth work. Anything faster than this would show revolution marks on the finished board, the old four-square planer head with its thick, clumsy, hand-ground knives being almost impossible to balance perfectly.

One could not, without clairvoyant power, foresee that the 25 ft. per min. feed would some day be multiplied twelve times and that lumber would be shot through these machines at the rate of 300 ft. per min. But it was possible to arrive at the conclusion that an improvement in planer knives would mean an increase in planer feeds. Here was an opportunity for some knife-making shop to analyze conditions, find the weak point and help to push aside the obstacles holding back the progress of the wood planer.

The installation choice of a new machine is taken more seriously in the small shop than in the large one. No doubt this is because one machine among many does not affect the whole as much as when one is added to a few, just as a single vote in a small town is of much more relative importance in local elections than one vote in a large city. The installation of the wrong machine in a big shop means annoyance and a small loss; the installation of the wrong machine in the small shop may put it out of business. On the other hand, not buying a machine that is needed, while it will not result in a sudden calamity, is likely to terminate in a case of gradual dry rot.

The "Rogers Boys," as J. R. and Francis P. Rogers, Jr., are known in Worcester and vicinity, believed that a suitable surface grinder would solve a problem of the wood-planer knife. Not only had they the conception of what was needed, but not finding a suitable machine for this purpose on the market, they designed and had built the special machine illustrated in Fig. 2—an act that involved playing a \$10,000 stake against their belief. That this was an investment and not a gamble is evidenced by the fact that from this machine came the first high-speed steel wood-planer knife made, and others have been coming from it ever since.

This machine is of interest, not only as an example of good judgment displayed at an opportune time, but also for what it will do. The grinding wheel is 24 in. in diameter with an 8½-in. face. Running at 5,000 ft. per min. it is so free from vibration that one cannot tell whether or not it is in motion, even when holding to

## MAKING SMALL SHOPS PROFITABLE

his ear a screwdriver with its end applied to the wheel bearing.

The table of this machine is 10 ft. long, its entire length being equipped with Walker magnetic chucks having a width of  $8\frac{1}{2}$  in. There are two table speeds—40 and 60 ft.—one for roughing and the other for finishing. On the class of work produced on this machine, limits and finish are held exceptionally close, some knife specifications calling for tolerances no greater than 0.00025. In view of this requirement the accomplish-

you consider where the price of high-speed steel is today and where it is quite likely to go, there may not be much to be wondered at after all. The accumulation of dirt shown in the tank at *A* in Fig. 1 is in reality high-speed steel grinding dust floating on top of water. This material is carefully saved, packed and shipped to the steel mills, where every bit of tungsten is eagerly welcomed.

One can get an idea of the proportions of a high-speed steel wood-planer knife from the illustration at *A*

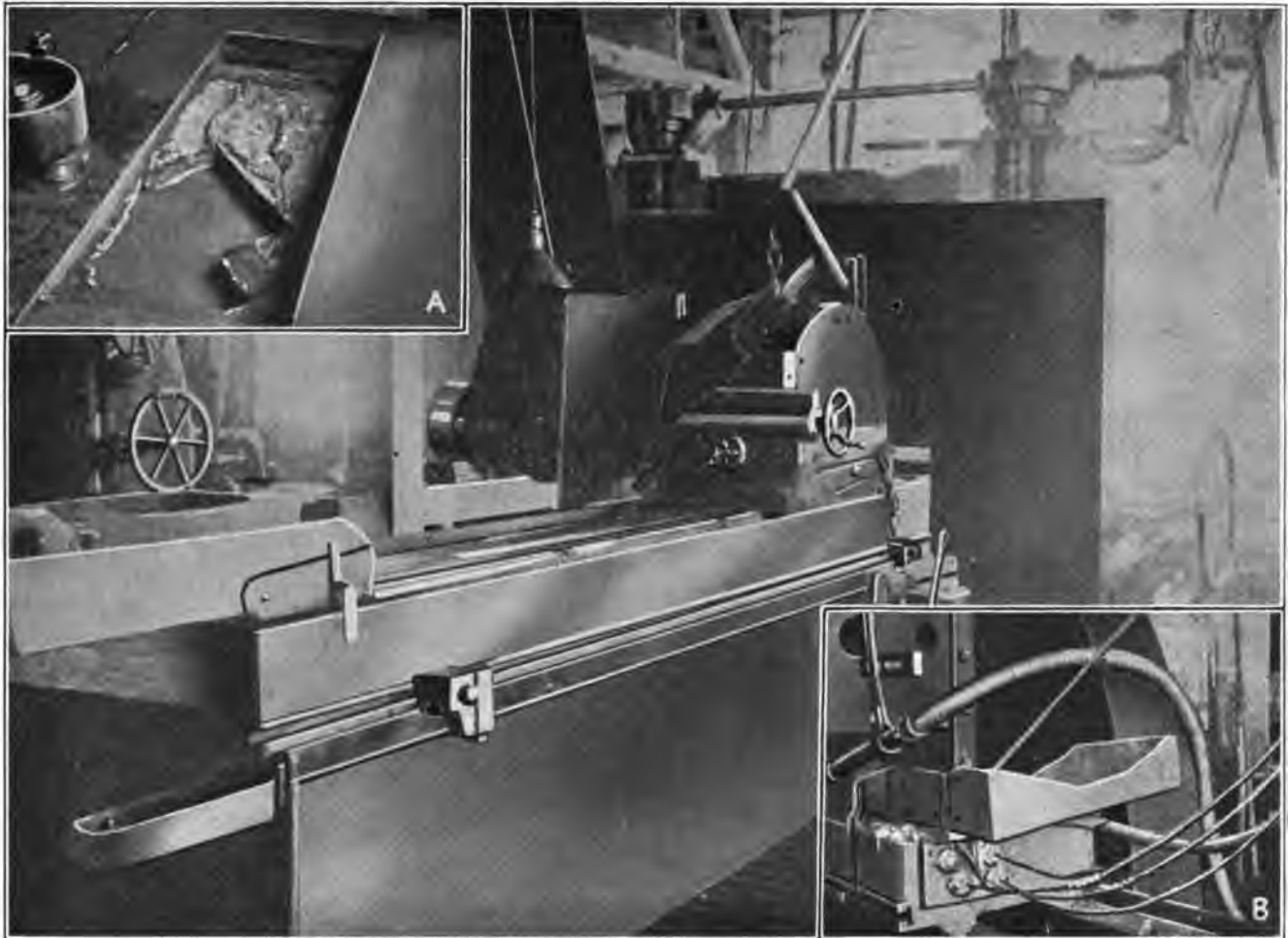

FIG. 2. THE SURFACE GRINDER THAT PROVED TO BE THE TURNING POINT

ment of this machine in removing  $\frac{1}{32}$  in. per hr. from a surface of 120 in. long and  $8\frac{1}{2}$  in. wide is rather remarkable. The table is reversed by a pneumatic clutch.

The rear view of this machine, seen at *B*, displays  $2\frac{1}{2}$ -in. flexible steel hose through which cooling water is applied to the wheel. When the machine was first tested out, this hose was not fastened as securely as is shown, but was held by a husky negro who directed it upon the back of the wheel. The gentleman, becoming absent-minded during the course of events, allowed the nozzle to deviate from its proper path; as a result the  $2\frac{1}{2}$ -in. stream projected between the housings and knocked a couple of interested spectators from a bench alongside the table. What happened to the spectators is known, but what happened to the darkey is not related.

One does not see anything unusual in the practice of saving the sweepings from the floor of a mint in which gold coins are being made, but it is rather strange to find a similar practice in a knife shop. However, when

in Fig. 3. They are from  $\frac{1}{8}$  to  $\frac{3}{16}$  in. thick, from  $1\frac{1}{2}$  to 2 in. wide and from 4 to 50 in. long. The heat-treatment and straightening of a high-speed steel blade of such proportions require a high degree of skill. All these blades are hardened in Kenworthy furnaces using fuel oil vaporized by steam under a pressure of 125 lb. and are quenched in Houghton's soluble quenching compound. After quenching, they are tempered, or "let down," to approximately 600 deg. F. Before this, however, they must be straightened, a peculiar thing about high-speed steel being that it is impossible to straighten it after this second heating.

### PLANING IRON AT 230 FT. PER MIN.

The machine-shop man who has been unpleasantly surprised by the ease with which some high-speed drills and reamers break under slight provocation would expect a thin high-speed steel knife of this kind, hardened to a scleroscope hardness of 85, to be a rather delicate and fragile tool. He would change his mind if he could see

the piece of 1½-in. angle iron shown at B in Fig. 3, which was accidentally fed into a double surfacer and planed both top and bottom for 18 in. of its length at a speed of 230 ft. per min., some ⅜ in. in depth being removed from one of the ribs and a full ½ in. from the entire surface of the other rib. The high-speed steel knives which did this fast iron planing were somewhat dulled, to be sure, but a grinding put them in condition for further cutting — of lumber.

Before the installation of this "turning-point machine" the Hankey company was doing what a number of other firms were also doing and in about the same way. The use of this machine upon high-speed steel knives, however, necessitated careful study of the heat-treatment of this material and led to a specialization in accurately ground high-speed steel knives and tools, which has been

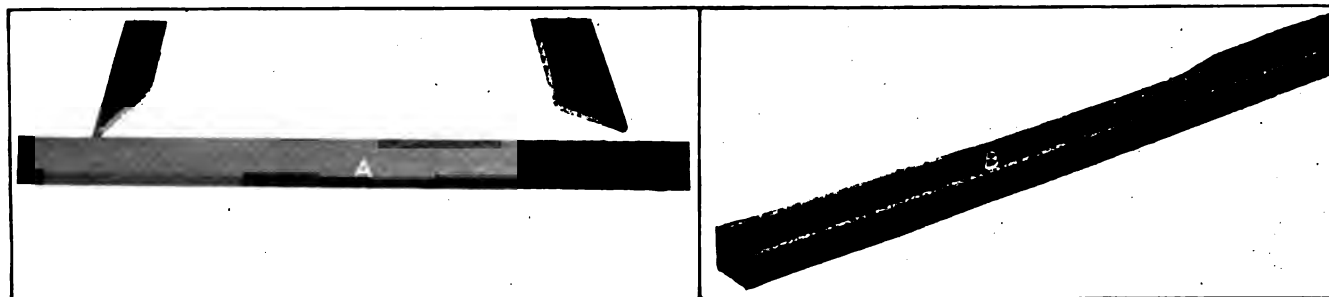

FIG. 3. HIGH-SPEED STEEL WOOD PLANER KNIVES AND WHAT THEY DID TO ANGLE IRON

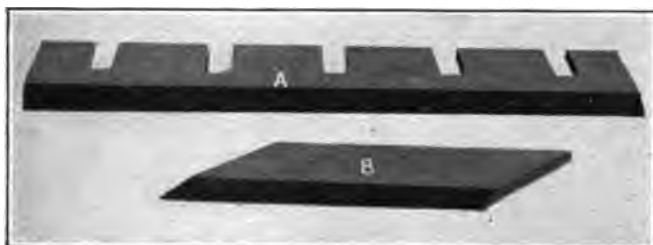

FIG. 4. COMPOSITE-STEEL WOODWORKING KNIVES

a profitable line of business. But the turning point was the installation of the grinder.

High-carbon and composite-steel tools and knives are also heat-treated and ground at this plant. Two of these are shown in Fig. 4, the one at A being a wood-planer knife for a square-cutter head and the one at B being a miter knife. They have soft steel backing on tool-steel edges. The furnace weld is rolled, and the grinding of a piece of this kind, one part of which is soft and one part hard, without leaving a mark at the junction of the two pieces may be considered a noteworthy job. In fact, the face of these blades must be ground to a radius, that is, held to very close limits. One and one-half thousandths is allowed for location of this radius centrally with the blade, and 0.001 in. is allowed on the length of the radius.

It is not often that a small shop is able to change the grade of its product as markedly as this, owing to the installation of a new machine. Every small shop, however, can keep in mind the fact that each machine installed should be a turning point toward better work and more profits.

This thought, coming at the time when new equipment is to be purchased, will influence the buyer to select the machine best suited to his needs regardless of what its cost might be.

## Weighing Patterns and Castings by Their Displacement of Water

By W. H. SARGENT

The writer was puzzled to know how to find the size of a pattern for a scale weight the casting from which was to weigh a certain definite amount. The pattern was of such irregular shape that its volume could not be accurately computed, and it was not possible to take off a trial casting. In my trouble I remembered Archimedes and his stunt with the king's crown, and I thought if I could find the weight of a quantity of water equal in volume to the pattern, then the casting would be to the pattern what the weight of iron is to the weight of water. I punched a hole through the side of

a tin can near the top, filled it with water to that point and immersed the pattern. I caught and weighed the water that ran out, which was, of course, equal in volume to the pattern. Multiplying the weight of my "water casting" by the specific gravity of cast iron gave me the corresponding weight of an iron casting.

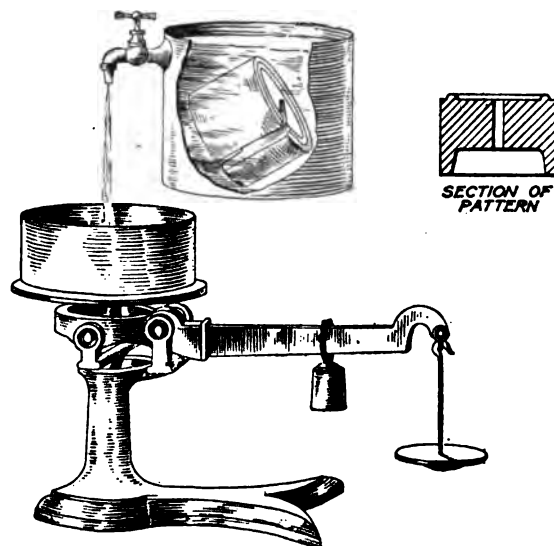

WEIGHING BY PROXY

Another practical application of this principle is finding the weight of a casting when no scale is at hand large enough to weigh the casting itself. Fill a pail or tub exactly full of water. Immerse the casting; catch and weigh the water that overflows; multiply the amount by the specific gravity of the material and you have the weight of the casting. Thus a casting of nearly 200 lb. can be weighed "by proxy" on a 25-lb. scale with a considerable degree of accuracy.

# Spring Fever in the Small Shop

BY JOHN H. VAN DEVENTER

---

*SYNOPSIS — This is a "Dave Hope" story, telling how the inmates of his small machine shop were afflicted with spring fever and how they were cured by inoculation.*

---

There is a disease not mentioned in the medical books. It spreads its influence broadcast over the country each year and spares not rich nor poor, young nor old. It affects most strongly those whose occupations keep them within doors and is a disease that every machinist's apprentice and even the machinist himself suffers from each year. The germs of this disease are frozen up and harmless during the winter season; their busy time is the month of May:

When the buds begin to blossom  
And the bees begin to hum;  
When you feel like playing 'possum  
And your job seems on the bum.

It is at this season of the year that the machinist in the large or the small shop picks out a soap box or nail keg as a resting place from which he can with the least effort observe the slow progress of the thirty-second-inch feed crawling over the surface of the work. But while his eyes are on the machine, his thoughts are elsewhere. In imagination he is feeling the warmth of the sun upon the back of a neck that has been protected from sleet and storms for many months by an upturned coat collar. He is imagining the satisfaction of indulging his five senses, individually and collectively, with the sights, sounds, smells, tastes and feelings of a rejuvenated earth. And just about the time when his imagination takes him to the crystal-clear inland lake crammed with fish as hungry as starving wolves — bang! The whole thing is punctured by the sarcastic voice of the boss: "Get rid of that hook-worm and double up on your feed!"

## SYMPTOMS OF SPRING FEVER IN DAVE'S SHOP

There were obvious signs that this spring malady had attacked Dave Hope's small shop. One convincing symptom was evident in Sandy McPherson's location out of doors, for he had moved the portable work bench from within and was doing his filing under the sky instead of under the shop roof. Reddy Burke, whose duties confined him to a close proximity to machines not so easily portable, looked rather disconsolate. As for the boy and the half-dozen other men who comprised the personnel of the shop, the evidence of the disease was unmistakably written upon them and displayed in every motion.

Dave Hope had not overlooked these indications and, in fact, felt some of the symptoms working in his own system. "This thing is going to cost us some money," he reflected, "because the trouble is sure to last for two weeks at least. During this time one after another of the boys will be taking a day off now and then, and it isn't in my disposition to tell them no, for I'll probably be doing the same thing myself." Just at this moment his eyes rested upon the magazine section of the preceding week's Sunday paper, which happened to lie open at an article entitled "How Disease Is Made Harmless by Inoculation." "By George!" exclaimed Dave to himself; "I

wonder if there isn't a way to inoculate against spring fever."

He read the article with considerable interest and found that the principle of inoculation is to treat the system with a dose of the disease bacillus that causes the complaint. "Looks like a case of fighting fire with fire," muttered Dave, lapsing into a period of silent reflection that lasted several moments. Then he got up, slapped the desk with his fist and ejaculated, "By George, I'll do it!"

## DAVE GETS READY TO TRY THE INOCULATION

Next morning Dave did something that it was very unusual for him to do; he lined his men up and made a speech to them. Perhaps it should be called a talk rather than a speech, for there was nothing formal about it any more than about Dave himself.

"Boys, we're all coming down with a bad case of spring fever. I've got it myself, and I know that you have. And I don't blame you for it. But there are some orders here that we've got to get out — that 12x12 engine for Jones' sawmill, the road roller for the town and that duplex pump for Tim Ebbets. Now I'll tell you what we'll do — you boys pitch in and clean these up by Friday night, and we'll shut down until Monday morning, with the condition that all of us together go out for a two days' camp in the woods."

The speech of an eloquent statesman was never received with any more enthusiasm than were these few words of Dave's. All hands pitched in with a vigor that gave evidence of the success of the first inoculation.

## STARTING OFF FOR THE CAMPING GROUNDS

On Saturday morning at sunrise the wheels of the one-horse farm wagon creaked under the load of eight men and a boy and sundry equipment in the nature of provisions and camp material. Fishpoles were a prominent feature included in this assortment of goods, for every small-shop man is instinctively a fisherman by second nature. Dave had suggested that the party go on foot, thinking that the spring-fever inoculation would take place more rapidly under such circumstances, but compromised on a farm wagon without springs.

It was very pleasant jogging along the fresh-smelling country road, and the occasional bumps encountered by the springless farm wagon as it rolled over furrows left by recent freshets did not cause any lessening of the enjoyment, unless it was on the part of the boy, who was jolted off the back of the wagon by an unusually severe bump. As the sun grew hotter and the road grew hillier, it was necessary for the party to get out of the wagon and "spell" the horse, who seemed to be suffering from spring fever himself. Coats came off one by one, and beads of perspiration began to bathe newly acquired sunburn. Dave had chosen the road and had taken care to pick one with very little shade.

"Gee," said Tom, the boy, "I didn't think it could be as hot as this in May!"

"Hot, is it?" exclaimed Reddy Burke. "T'ink of the poor byes in Mexico — this is a rayfrigorator be comparison."

The destination of the campers was an inland stream

## SPRING FEVER IN THE SMALL SHOP

girded by woods. It was a location seldom visited by fisherman, being 18 miles from town and 10 miles from the nearest railroad, and for this reason might be expected to furnish exciting sport and appetizing meals. The country in this neighborhood was sparsely settled, but a farmhouse was encountered some six miles distant from the creek, and Dave stopped the wagon to buy some fresh milk and to have a word in private with the farmer.

### A RAID ON THE COMMISSARY DEPARTMENT

The two days' supply of eatables in the commissary department had begun to melt under the attack of nine hungry appetites. "If you lads dinna refrain frae eatin' the noo, we will have nowt for breakfast the morn's mornin'," cautioned Sandy.

"We'll have fresh fish for breakfast anyway," replied Bill Evans; "there's a dozen breakfasts and dinners too, swimmin' in that there creek."

Upon arrival at the destination the horse was unhitched from the wagon and tethered in a shady patch of woods. Fishpoles were hurriedly sorted out from among other contraptions, Reddy Burke finding difficulty in unearthing his from beneath the big fly tent that had been brought along for sleeping quarters.

There was a rush for strategic positions on the bank of the creek. Sandy McPherson was the first to get into action, baiting his hook with a "night walker" the size of which insured an ambitious catch if any at all. Two minutes later, while Sandy was lighting his pipe, a ferocious and unexpected pull yanked the pole from his left hand. It was a steel pole, and not having the buoyance of the more common wooden kind, it disappeared beneath the surface, followed by a shower of Scotch imprecations.

"Hoot, a beastie wi' sic a pu' can be nae less than a hippopotamus," exclaimed Sandy, after he had cooled down a bit.

This experience heightened the anticipation of the rest of the party, proving as it did that there was big game in the creek. And in confirmation of this, Reddy Burke's pole began to bend vigorously. "Begorry, I hov the baste," exclaimed Reddy, "and it's meself that will bring the craytur safely to terry firmmy."

### REDDY BURKE CATCHES A BIG ONE

Then ensued a momentous struggle between an excited Irishman at one end of a fishpole and a fish of unknown species at the other. The battle waged with varying success for a half-hour, the rest of the boys dropping their poles and offering varied suggestions as to the best way of landing the catch. Finally, human skill aided by the elasticity of a fishpole conquered. "Get ready to hov a look at the biggest fish in the counthry," exclaimed Reddy, shortening up on his line. But it wasn't a fish—it was a gigantic snapping turtle.

That place seemed to be the headquarters of the snapping-turtle trust. One after another received promising bites, only to find them given by these hard-shell creatures who monopolized the stream. So many hooks were lost in this pastime that the fishermen discontinued their fishing and sought the shade of near-by trees.

The noon repast finished up most of the provisions. It was followed by a nap for all of the party but Dave, who seemed to have business back in the woods. So soothing was the outdoor air of spring that, when the

amateur campers awoke, it was after 6 o'clock and they were as hungry as wolves. By unanimous consent they started for the wagon. But when they reached the clearing where it had been left, there was no sign of either horse or wagon!

### MYSTERIOUS DISAPPEARANCE OF BOARD AND LODGING

"Sure, 'tis a likely place for the fairies," exclaimed Reddy; "but if they bewitched the baste and the wagon, they've left tracks behind thim to indicate it." Here he pointed to unmistakable wheel and hoof prints. "Some dhirty rascal has cabbaged the commissary department!"

They succeeded in following the tracks as far as the crossroad, but here the wind had obscured the marks and the men were not enough skilled in wood craft to detect which branch had been taken. Besides, it was growing dark, they were without shelter, and the evening breeze began to feel chilly.

"The best thing for us to do," advised Dave, "is to find some barn where we can sleep. The nearest farmhouse is six miles away, and I suggest that we follow the creek road, where we may find something nearer."

A six-mile walk without supper did not attract the rest of the boys, and it was agreed to try the creek road. It was quite dark by this time, and everyone had parted with his last bit of good nature. Tom, the boy, apparently could see in the dark better than any of the others. "There is a building over there, I think," he exclaimed, after the party had trudged a half-mile by starlight. "If you fellows will wait here a minute, I'll go over and see what it is."

He came running back in a few moments. "It looks like a good place to sleep," said he; "it's a shed with a lot of sawdust on the floor."

### REDDY BURKE HAS A NIGHTMARE

Reddy Burke woke up two hours later from a nightmare in which he, a morgue and a slab of ice played the principal parts. He found that he had sunk downward quite a bit in his bed of sawdust, and he was surrounded with icy cold water. "Wake up, lads," he bellowed at the top of his voice, "the creek is rising and youse will all be drowned!" Someone struck a match, and by its flicker they could see that they had gone to sleep in an ice-house!

Two hours later the moon looked down on a disconsolate party trudging back toward town. It was almost dawn when they came to the farmhouse where the milk had been obtained. "Guess I'll run in here and see if the farmer has seen anything of our horse and wagon," said Dave.

He did not have much trouble in arousing this gentleman, who led him back to the barn and the missing conveyance. "Wall, I reckon you're satisfied that I followed directions all right enough, aint ye?" said the farmer, with a sly wink as he pocketed Dave's two-dollar bill.

The horse ambled along with his load of homeward bound pilgrims, quite unconscious of the verbal abuse that was heaped upon him by men who were too tired to sleep and too angry to converse.

Sunday was spent at home in bed by the members of the camping party; and when they returned to work on Monday morning, the spring-fever inoculation was complete. Even Sandy McPherson moved his work bench back into the shop.

# Making Patterns and Castings for the Small Shop

BY JOHN H. VAN DEVENTER

**SYNOPSIS**— *What to avoid is even more important to know than what to do. This article throws cold water on the ambition of the small-shop owner who is thinking of operating his own foundry. Patterns also come in for their share of rapping.*

A foundry is a handy thing to have in connection with a big shop—you can blame most mistakes upon it. This abode of the sand rammer has always been a convenient "goat," and many a shop foreman would lose his job if deprived of its unconscious support when it comes to excuses for spoiled work.

When the time clerk trots down the line with a job that took an hour and a half longer than it should, what is more easy and soothing than to tell him that the cast-

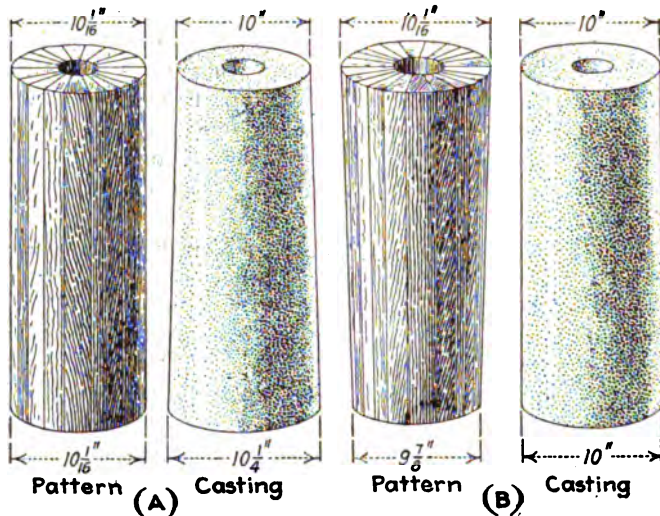

FIG. 1. TOM COOPER'S EXPERIENCE WITH ROLLS

ing was hard and sandy and that you think some cuss over in the foundry must have slipped a couple of files into the cupola? When the old man sits on your neck because a machine is three days overdue, what will change a disorderly rout into a glorious retreat more quickly than to tell him that the frame pattern was rapped so large that it required three cuts to get it down to finishing size? When a pulley or gear arm has cracks in it, how is it possible for these to have occurred in the casting anywhere but in the foundry where it was made? In one large shop with which I am familiar there is a saying as follows: "A slight error in the designing department, a mistake in the machine shop, a d— big blunder in the foundry."

While a foundry is so convenient in this respect, aside from its capacity to deliver castings, it is usually an expensive luxury when attached to a small shop. When castings can be bought on contract as cheaply as is possible nowadays, it is foolish to assume a new burden of responsibility with the prospect of such a slight saving as that between the cost to make and the cost to buy, especially where the castings that are bought need not be paid for

unless good, while those that are made must be paid for whether good or bad.

One of the supposed advantages of having your own foundry is in being able to get castings on time, but those who have foundries have come to believe that this advantage is not inseparably affixed to them. If the small-shop man is really looking for trouble, let him add the duty of a foundry superintendent and metal mixer to his already numerous and diversified duties and learn the 39 reasons why a casting can come out bad, starting with too high a barometric pressure and ending with too hard sand ramming, and he will feel as if he had his hands full.

There are of course exceptions to this even in the small shop. Some isolated cases exist where a foundry that can take no more than one heat a week will make a profit. But this is due to unusual conditions, such as the absence of competition; and since the majority of our small shops are in fairly close touch with competition, it does not apply in general.

There are some small-shop owners who think to add to their volume of business by adding to the number of

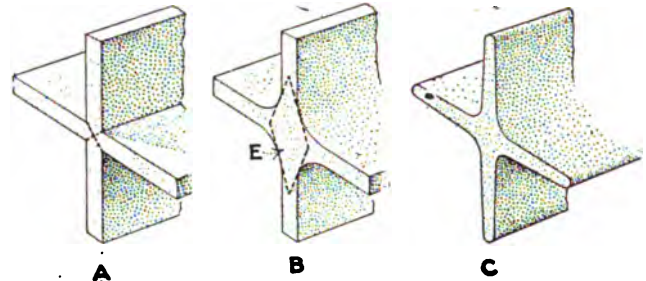

FIG. 2. TROUBLE WITH NOT ENOUGH AND TOO MUCH FILLET

departments in their plant. Not satisfied with an ordinary machine shop, they must have a foundry, blacksmith shop, pattern shop, nickel-plating department and what not. One shop owner of my acquaintance was doing a total volume of business of less than \$12,000 a year and yet kept adding one department after another. Most people find it hard to support simply a machine shop on this amount of annual business, let alone extending it over a blacksmith shop, foundry and pattern shop. In addition to spreading the money very thin, the capacity of an ordinary human being must be stretched to the breaking point when he has to look after such a great variety of things. You will find the most successful shops are those that find out what they can do to best advantage and then cut out everything else as much as possible.

The same reasoning applies to making patterns. It is hard to get some men to realize that this is a special trade in itself. Unless a man is in daily touch with foundry conditions, knows foundry problems and has had years of experience with them as well as with his own trade, he is not fitted to make a real pattern. What I mean by a real pattern is one for a piece of work that counts for something, not the ordinary odds and ends of junk required about the shop from time to time, which may be made from whatever is at hand.



## MAKING PATTERNS AND CASTINGS FOR THE SMALL SHOP

Old Bill Higgins, of Vermont, knew these facts as well as anyone and yet insisted on making his own patterns. But then he was a man who ran in unusually good luck. He said that to get a good casting you must have a good pattern; to get a good pattern you must have a good design; to get a good design you must have a good designer; and to get such a man you must have a lot of luck, so the whole casting business resolves itself into a matter of luck anyway, whichever way you look at it. Whereupon he would proceed to make a pattern that violated all the laws of nature. He would put the draft upside down and the cores inside out, mold it in too small a flask in the wrong kind of sand, ram it too hard and pour it too cold — and get a good casting!

Sometimes the carpenter finds that it falls to his part to make the small-shop patterns. They tell of one such wood butcher, newly hired by a small-shop owner, who, when told to put a little more draft on the pattern he was making, opened the window in front of the bench a bit wider!

Tom Cooper thought he knew enough to make a pattern for a plain cylindrical roll. He botched together a pattern such as shown at *A*, Fig. 1, allowing  $\frac{1}{16}$ -in. diameter

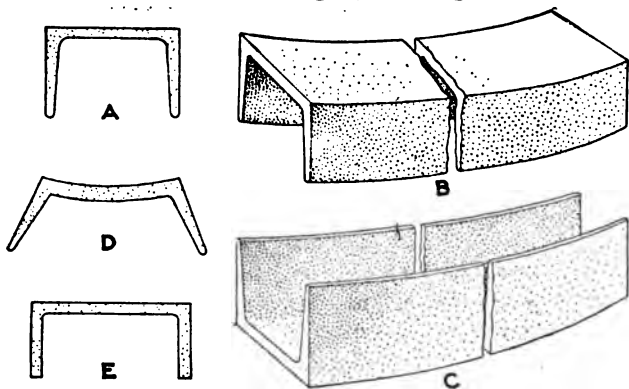

FIG. 3. CAME OUT DIFFERENT EVERY TIME IT WAS MADE

for shrinkage. He sent this over to the nearest foundry with instruction to cast it on end, so to get the surface clean all around. He was quite surprised on receiving the casting to find that one end of it was larger than the pattern. He jumped on the foundryman for rapping the pattern on this job with a sledge hammer, but got a quick come-back combined with the information that he should have made allowance for the pressure due to the head of liquid iron, which had expanded the mold at the bottom. After some experimenting he found the way to get a straight casting by making the pattern tapered, as shown at *B*. But he used up several hundred feet of good pattern lumber and a lot of time finding this out.

### A JOB THAT BOTHERED TOM COOPER

Another little job that bothered him some was a pattern of which there were several + sections. Tom first made these as illustrated at *A* in Fig. 2 and got his pattern back in short order with a request to put fillets in the corners. He did so in the way seen at *B* and was shocked to find that too much fillet is as bad as too little, for the central portion was so heavy in comparison with the ribs that the unequal cooling set up heavy strains that resulted in cracks. Finally, the foundry owner took pity on him and told him to make it as shown at *C*, so that there would be a gradual change in the width of sections from

one part to another. But while fussing around with these things, he overlooked a bad error in a machine for his best customer, and it was shipped without remedying the defect.

Not yet having his fingers badly enough burned, Tom tackled a pattern which had a channel cross-section, like that at *A* in Fig. 3. This pattern was straight, to be sure, but the casting came to him as hollow as an empty stomach, looking quite like the illustration at *B*. He called up the foundry on the phone, but dropped the receiver in a hurry when the foundry boss told him that he did not pay his men to furnish brains for amateur pattern makers. He sent the pattern to another foundry and got back a casting bent in the opposite direction, like the one shown at *C*. Then he changed the pattern a bit, thinning the metal at the center and thickening it at the ends. The casting which resulted, shown at *D*, reminded him of a dog stretching after a nap. In desperation he gave the job to a pattern maker, who solved the problem by thickening the ribs as at *E*.

A mistaken belief is a hard thing to kill, and Tom's

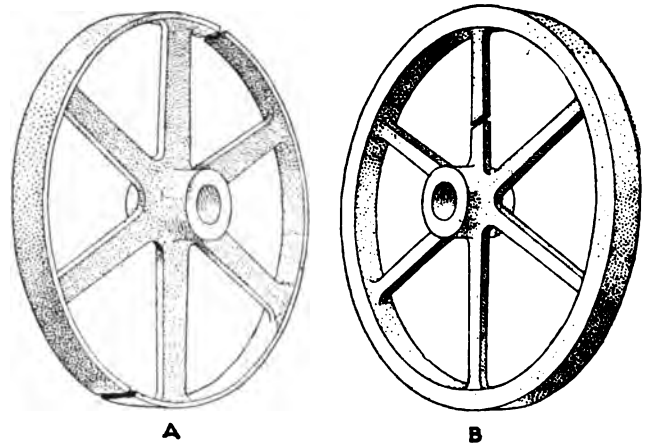

FIG. 4. CURING ONE DISEASE BROUGHT ON ANOTHER JUST AS BAD

belief in his pattern-making ability was not yet dead, even after such a severe shaking up, so he tackled a pulley.

A cast-iron pulley is one of the most innocent appearing objects, but beneath its honest sandy skin it contains a heart more full of stresses and strains to the square inch than anything else one can imagine. First, Tom made the rim light, as in Fig. 4 at *A*, so that it would not require a heavy cut for finishing. As a matter of fact it did not require any, meeting its finish while cooling in the sand. Then he made the rim heavy, so that this would not happen again, but unfortunately, with the results shown at *B*, the arms breaking this time instead of the rim. He lightened the rim a bit and made the arms a little heavier, but found that, although the casting looked good, the arms would snap under the slightest provocation, the hub thickness being much too great for equal cooling. Finally, it dawned upon Tom that he did not know much about pattern making and that it would be cheaper for him to have the few patterns he required made by someone who knew how.

Not only with reference to making patterns and castings, but with almost everything else the following should be remembered: A man can know nearly all there is to know about one thing, he can know a great deal about a few things, or he can know a little about a great many things. Take your choice, but remember that success will come only with the proper choosing.

# The Small-Shop Grinding Wheel

BY JOHN H. VAN DEVENTER

*SYNOPSIS*—Although often wrongly selected, incorrectly mounted, improperly speeded and unfavorably used, the small-shop grinding wheel plays no inconsiderable part in getting out the work. This article is intended as a help to the better understanding and use of this crude but effective shop appliance.

Some day perhaps the creator of "Happy Hooligan" will lead him into a small machine shop and then show us in pictures what happens to him. The old fellow must be getting tired of the regular routine of mishaps and would appreciate something different, such as getting bumped with a planer table or being scalped by a driving belt. But for all-around entertainment let him be intro-

duced to a grinding wheel. And mind you, I am speaking of the simple apparatus found in all shops, which consists mainly of wheels and belts—not the "grinding machine" that is nine-tenths machine and only one-tenth wheel. On these simple appliances tools are ground, keys are fitted, castings are snagged, hurry-up jobs are surfaced, that which is too long is shortened, that which is too wide is made narrow, and that which is rough is made smooth. Yet in spite of its broad application, you find in many shops that grinding wheels are more abused than used.

The error that I will attack first, because it is the most common one, is the lack of running balance.

"What's that, an earthquake?" you ask as you feel the floor beginning to shake and tremble.

"Oh, no," is the reply, "it's just Tom starting up the grinding wheel."

One can hardly stand within ten feet of a grinding wheel in the average shop without feeling the vibrations running up and down his backbone. That this is an entirely unnecessary condition is seen when you consider that plain grinding machines with wheels running at the limit surface speed are practically free from vibration. They have to be, in fact, to produce accurate work. The result is not obtained by sleight of hand, but is due to three simple factors—a substantial base, true spindle and bearings, and well-balanced running parts.

The first essential of a smooth, quiet running wheel is a heavy frame. It is easier for a dog to shake a little tail than a big one. Some shop owners sidetrack the vibration question, in a manner shown in Fig. 1, by attempting to mount the grinding wheel on a springy frame, with the

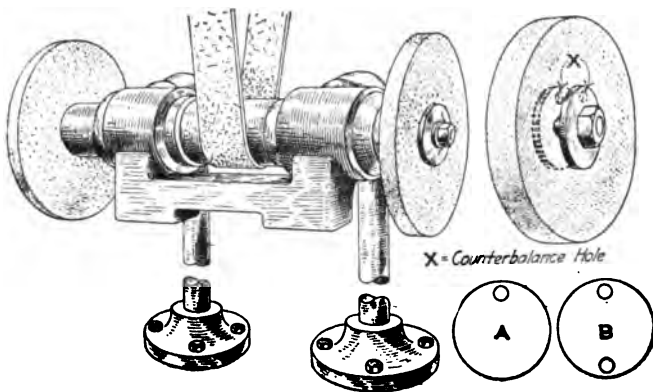

FIGS. 1 AND 2. TWO WAYS OF SIDETRACKING THE VIBRATION QUESTION

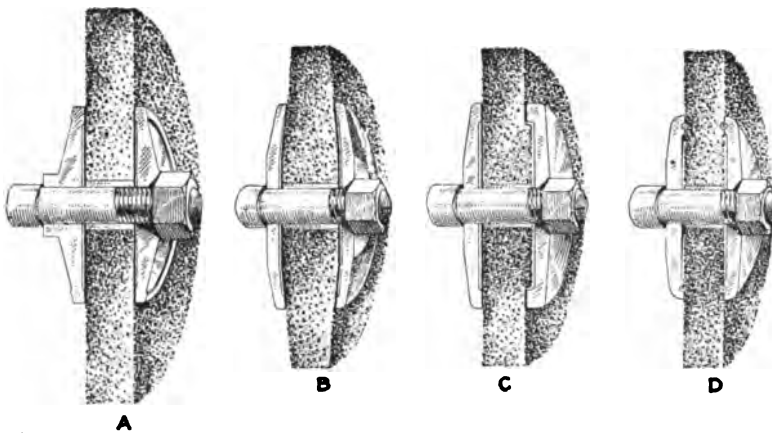

FIG. 3. FOUR METHODS OF MOUNTING GRINDING WHEELS

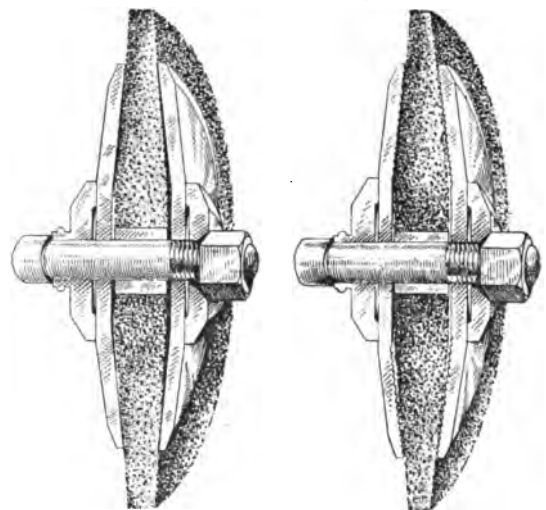

FIG. 4. SAFETY COLLAR MOUNTING

duced to a grinding wheel. Picture to yourself the expression of his face after feeling of the wheel with his fingers or upon taking hold of the "heavy" end of the piece of work! Imagine him trying to light his "snipe" at a stream of sparks. Picture him reclining gracefully against a swiftly moving snagging wheel and then making a hasty exit with a newspaper held to conceal the damages!

The small-shop owner finds as many ways to make a grinding wheel helpful as a Hooligan would find to make

idea that it will absorb vibration. Considering the amount of work that is expected from a grinding wheel, it should not be begrudged a sufficiently heavy base.

It is not uncommon to find shop owners with the idea that a grinding head may be shaken together out of the crudest kind of material. Bearings and spindles that are shaken together in this manner will continue to shake together as long as they last. The speed at which a grinding wheel must run requires not only a smooth, round, true and well-balanced spindle, but also bearings of the

## THE SMALL-SHOP GRINDING WHEEL

most improved design, well lubricated and dustproof, and the spindle pulley must be carefully balanced.

"Shall I use a plain bearing or a ball-bearing grinder head?" This depends absolutely upon whether you will keep the wheel running true and in balance, or allow it to vibrate. Ball bearings on apparatus of this kind will save power, especially on wheels that are run idle a large part of the time. But there is no make of ball bearing that can possibly live under the hammering punishment of an unbalanced emery wheel.

Grinding wheels when received from their manufacturers are likely to be in good running balance; but as the density of the material in these wheels is not uniform, it is quite likely that after one of them is worn down an inch or two it will get out of balance. A means of quickly overcoming this is shown in Fig. 2. It consists of balancing flanges having light spots, which may be placed either opposite or together, or in any other relation to secure the desired counterbalancing effect. The use of such flanges is a mighty good scheme and saves time in making a wheel vibrationless.

While vibration is the most common defect of the grinding wheel, it is not the most important one, if the importance of these things is to be measured by their effects on safety. Bad wheel mountings and lack of guards have been responsible for more accidents than any other causes. I for one would much prefer to stand in front of a correctly mounted wheel running 10 per cent. overspeed than in front of a badly mounted wheel running 10 per cent. underspeed.

Clang! Clang!

"There goes the ambulance. Wonder what's the matter! Oh, it's old Bill from the Triumph Works—he's all smashed up. Emery wheel let go and hit him. They say it broke three ribs and tore off half of his face—mussed him up so you wouldn't know him. Oh, well, such things will happen. Say, ain't this war dreadful!"

Old Bill will spend the next two months in the hospital—if he is lucky or (unlucky) enough to live at all. When he comes out he will be as complete a wreck as any shrapnel-torn victim of bloody carnage. Bill's boss says the war should be stopped—that it's a shame for people to allow such things to happen nowadays. But why did *he* allow Bill to run his wheel without a guard and with flanges that were too small? That crime of negligence will stand against Bill's boss as black as many of the war-inflamed atrocities against those who in blind anger perpetrate them. You can't stop the war, Mr. Small-Shop Man, but you can make your grinding wheels safe! The old excuse that "My work won't allow of a guard" is getting threadbare and won't be presentable much longer.

Grinding-wheel guards have been illustrated so frequently in the columns of the *American Machinist* that I will not attempt to illustrate them here. All reputable makers of grinding stands equip them with guards, and if the stand is a home-made affair the guard can be also. Make the scroll out of  $\frac{3}{8}$  or  $\frac{1}{2}$ -in. boiler plate, and bolt on side plate as an additional precaution. Keep the inside diameter of the scroll as near that of the wheel as

possible, so that if a wheel lets go, it can't get far enough to work up much momentum.

There are certain principles in connection with mounting a grinding wheel which have been found by experience to lessen the risk of breakage. First, the bore of the wheel should be about 0.005 in. larger than the diameter

TABLE 1. MINIMUM SIZES IN INCHES OF MACHINE SPINDLES

Diam. in in.	Thickness of Wheels in Inches											
	$\frac{1}{4}$	$\frac{3}{8}$	$\frac{1}{2}$	$\frac{3}{4}$	$1$	$1\frac{1}{4}$	$1\frac{1}{2}$	$1\frac{3}{4}$	$2$	$2\frac{1}{4}$	$2\frac{1}{2}$	$3$
6	$\frac{1}{8}$	$\frac{1}{8}$	$\frac{1}{8}$	$\frac{1}{8}$	$\frac{1}{8}$	$\frac{1}{8}$	$\frac{1}{8}$	$\frac{1}{8}$	$\frac{1}{8}$	$\frac{1}{8}$	$\frac{1}{8}$	$\frac{1}{8}$
7	$\frac{1}{8}$	$\frac{1}{8}$	$\frac{1}{8}$	$\frac{1}{8}$	$\frac{1}{8}$	$\frac{1}{8}$	$\frac{1}{8}$	$\frac{1}{8}$	$\frac{1}{8}$	$\frac{1}{8}$	$\frac{1}{8}$	$\frac{1}{8}$
8	$\frac{1}{8}$	$\frac{1}{8}$	$\frac{1}{8}$	$\frac{1}{8}$	$\frac{1}{8}$	$\frac{1}{8}$	$\frac{1}{8}$	$\frac{1}{8}$	$\frac{1}{8}$	$\frac{1}{8}$	$\frac{1}{8}$	$\frac{1}{8}$
9	$\frac{1}{8}$	$\frac{1}{8}$	$\frac{1}{8}$	$\frac{1}{8}$	$\frac{1}{8}$	$\frac{1}{8}$	$\frac{1}{8}$	$\frac{1}{8}$	$\frac{1}{8}$	$\frac{1}{8}$	$\frac{1}{8}$	$\frac{1}{8}$
10	$\frac{1}{8}$	$\frac{1}{8}$	$\frac{1}{8}$	$\frac{1}{8}$	$\frac{1}{8}$	$\frac{1}{8}$	$\frac{1}{8}$	$\frac{1}{8}$	$\frac{1}{8}$	$\frac{1}{8}$	$\frac{1}{8}$	$\frac{1}{8}$
12	$\frac{1}{8}$	$\frac{1}{8}$	$\frac{1}{8}$	$\frac{1}{8}$	$\frac{1}{8}$	$\frac{1}{8}$	$\frac{1}{8}$	$\frac{1}{8}$	$\frac{1}{8}$	$\frac{1}{8}$	$\frac{1}{8}$	$\frac{1}{8}$
14	$\frac{1}{8}$	$\frac{1}{8}$	$\frac{1}{8}$	$\frac{1}{8}$	$\frac{1}{8}$	$\frac{1}{8}$	$\frac{1}{8}$	$\frac{1}{8}$	$\frac{1}{8}$	$\frac{1}{8}$	$\frac{1}{8}$	$\frac{1}{8}$
16	$\frac{1}{8}$	$\frac{1}{8}$	$\frac{1}{8}$	$\frac{1}{8}$	$\frac{1}{8}$	$\frac{1}{8}$	$\frac{1}{8}$	$\frac{1}{8}$	$\frac{1}{8}$	$\frac{1}{8}$	$\frac{1}{8}$	$\frac{1}{8}$
18	$\frac{1}{8}$	$\frac{1}{8}$	$\frac{1}{8}$	$\frac{1}{8}$	$\frac{1}{8}$	$\frac{1}{8}$	$\frac{1}{8}$	$\frac{1}{8}$	$\frac{1}{8}$	$\frac{1}{8}$	$\frac{1}{8}$	$\frac{1}{8}$

of the spindle, or in other words, an easy fit. The inner flange should be fixed to the spindle, either being shrunk on and turned in place or mounted as a light drive on a sliding key. Both flanges should be recessed so that the wheel is grasped by the outer edges of the flanges. Blotting-paper gaskets should be placed between the flanges and the wheel, and the wheel itself should not be clamped too tightly. These principles apply to any one of the

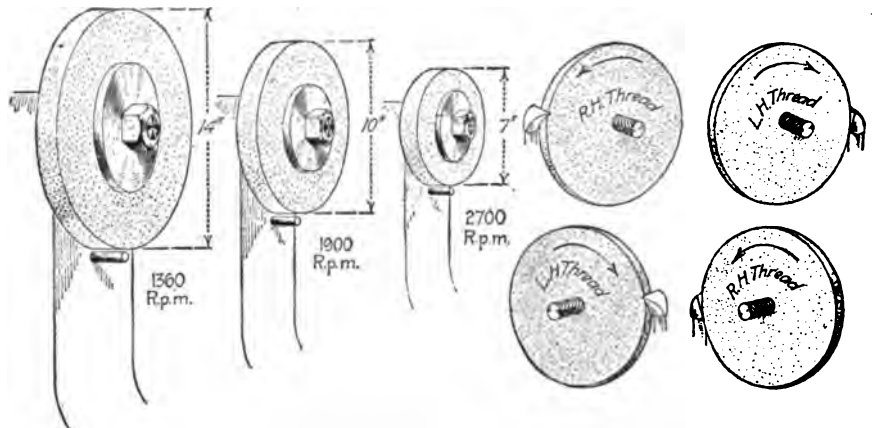

FIG. 5. KEEPING GRINDING WHEELS AT PROPER SPEED

FIG. 6. BE SURE THAT THE SPINDLE NUT TENDS TO TIGHTEN

four methods of mounting, shown in Fig. 3, of which the most common are shown at A and B, being what are called the "straight" mounting and the "safety" mounting respectively. Unguarded wheels should be of the safety type, with flanges so large that the wheel itself does not extend over two inches beyond them. The use of these flanges, however, should not be taken as an excuse

TABLE 2. DIMENSIONS IN INCHES OF TAPERED FLANGES AND TAPERED WHEELS WHERE HOODS ARE NOT USED IN CONJUNCTION THEREWITH

a Maximum flat spot at center of flange. b Flat spot at center of wheel. c Minimum diameter of flange. d Minimum thickness of flange at bore. e Minimum diameter of recess in taper flanges. f Minimum thickness of each flange for single taper at bore.

Diam. of Wheel in in.	a	b	c	d	e	f
6	0	1	3	$\frac{3}{8}$	2	$\frac{3}{8}$
8	0	1	5	$\frac{3}{8}$	$3\frac{1}{2}$	$\frac{3}{8}$
10	0	2	6	$\frac{1}{2}$	4	$\frac{1}{2}$
12	4	$4\frac{1}{2}$	6	$\frac{3}{4}$	4	$\frac{3}{4}$
14	4	$4\frac{1}{2}$	8	$\frac{3}{4}$	$5\frac{1}{2}$	$\frac{3}{4}$
16	4	6	10	$\frac{3}{4}$	7	$\frac{3}{4}$
18	4	6	12	$\frac{3}{4}$	8	1

to do without a guard. The ideal scheme may be said to be to use both precautions, making doubly sure against accident. A well-known form of safety flange is shown in Fig. 4. It is the product of the Safety Emery Wheel Co., of Springfield, Ohio.

Be sure that the wheel rotates in a direction that tends

## MAKING SMALL SHOPS PROFITABLE

to tighten, and not loosen, the outer flange nut. Vibration will cause a nut to dance off of the end of the spindle if this precaution is not taken, and it is sometimes annoying to have to dodge the wheel that follows, or to repair the hole in the shop roof left by its exit. The illustration, Fig. 6, shows the proper thread to use for various rotations and hands of wheels.

Grinding wheels cut most efficiently at certain definite speeds, depending upon the grain, grade and use. Usually this speed is stamped upon the wheel by the makers, in terms of revolutions per minute. This does very well for a new wheel; but as work is done and the wheel is dressed, it becomes smaller in diameter, and while the

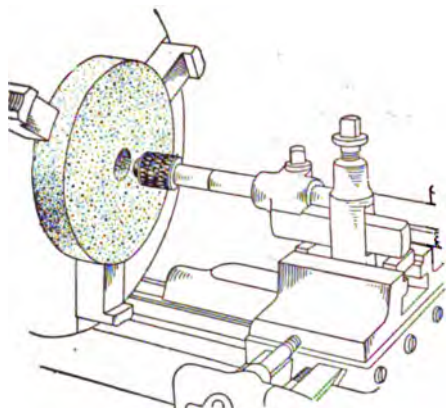

FIG. 7. ENLARGING THE HOLE IN A GRINDING WHEEL

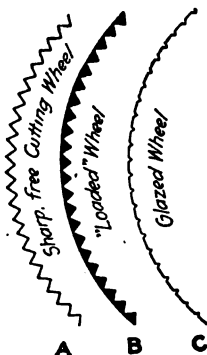

FIG. 8. THINK OF THE GRINDING WHEEL AS A CIRCULAR SAW

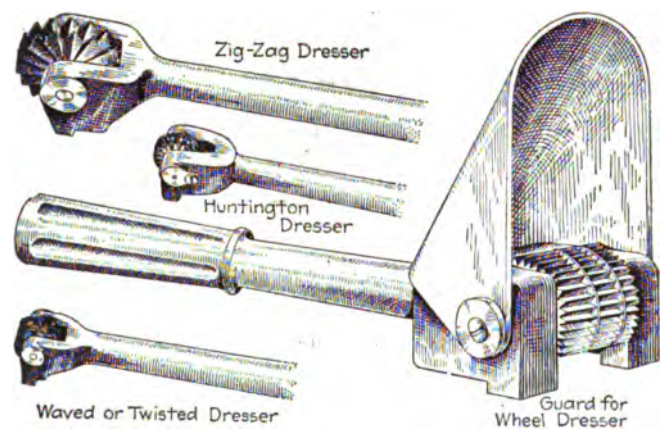

FIG. 9. PLENTY OF VARIETIES TO CHOOSE FROM

revolutions per minute stay the same the surface speed decreases and the wheel becomes less efficient. The scheme shown in Fig. 5 is a good one to overcome this drawback in a shop where two or more grinding stands are in operation. As the wheels become smaller, they are transferred to spindles of higher speed. Limit pins are used, as shown, to prevent getting on a wheel larger than is proper for the spindle speed.

A grinding wheel should be thought of as a circular saw. When the teeth are sharp and the cutting speed is right, it removes metal freely. Such a wheel is illustrated diagrammatically in Fig. 8 at A. A "loaded" wheel is shown at B, in which the teeth still remain but have their spaces filled with the material being ground, so that cutting is slow. A glazed wheel corresponds to a saw with its teeth ground away, and is shown at C. Very frequently the tendency of a wheel either to load or glaze may be overcome by running at a decreased speed. On the other hand, wheels which appear to be too soft are

made to operate correctly by increasing their speed, taking care, however, not to exceed the safe limit.

There is no excuse for the small-shop owner pleading ignorance of good grinding-wheel practice. The Committee Report of the National Machine Tool Builders on grinding-wheel and machine safeguards was published in

TABLE 3. DIMENSIONS IN INCHES OF STRAIGHT FLANGES AND STRAIGHT WHEELS AND FOR SAFETY FLANGES USED WITH PROTECTION HOODS

A Diam. of Wheel in In.	B Min. Outside Diam. of Flange	C Min. Diam. of Recess *	D Min. Thickness of Flange at Bore
6	2	1	3/8
8	3	2	3/8
10	3 1/2	2 1/4	3/8
12	4	2 3/4	1/2
14	4 1/2	3	1/2
16	5 1/2	3 1/2	1/2
18	6	4	3/4

\* Recess to be at least 1/16-in. deep.

the *American Machinist* in Vol. 40 on p. 921. An elaborate table showing the causes of emery-wheel accidents was published in Vol. 39, p. 1060. On p. 129 of 42 a comprehensive "safety code" drawn up by a committee appointed by the abrasive-wheel manufacturers was presented to the readers. All three of these reports, modified and combined, were presented in one paper<sup>1</sup> at the recent annual meeting of the American Society of Mechanical Engineers.

The following extracts are taken from this paper:

Before mounting, all wheels shall be closely inspected to make sure that they have not been injured in transit, storage, or otherwise. For added precaution, wheels other than of the elastic and vulcanite types should be tapped slightly with a hammer; if they do not ring with a clear tone they should not be used. Stamped wheels when tapped with a hammer may not give a clear tone. Wheels must be dry and free from sawdust when applying this test.

Wheel spindles shall be of sufficient length to permit of the nuts being drawn up at least flush with the end of the spindle, thus providing a bearing for the entire length of nut.

Protruding ends of the wheel arbors and their nuts shall be guarded.

Flanges, whether straight or tapered, must be frequently inspected to guard against the use of flanges which have become bent or sprung out of true or out of balance. If a tapered wheel has broken, the tapered flanges must be carefully inspected

TABLE 4. REVOLUTIONS PER MINUTE TO GIVE PERIPHERAL SPEED IN FEET PER MINUTE

Diam. of Wheel in In.	4,000	4,500	5,000	5,500	6,000	6,500
6	2,546	2,865	3,183	3,500	3,820	4,140
7	2,183	2,455	2,728	3,000	3,274	3,550
8	1,910	2,150	2,387	2,635	2,865	3,100
10	1,528	1,720	1,910	2,100	2,292	2,485
12	1,273	1,453	1,592	1,750	1,910	2,070
14	1,091	1,228	1,364	1,500	1,637	1,773
16	955	1,075	1,194	1,314	1,432	1,552
18	849	957	1,061	1,167	1,273	1,380
20	764	860	955	1,050	1,146	1,241

for truth before using with a new wheel. Clamping nuts shall also be inspected.

The work rest must be kept adjusted close to the wheel to prevent the work from being caught. Work rest must be rigid and always securely clamped after each adjustment.

A speed of 5,000 peripheral feet per minute is recommended as the standard operating speed for vitrified and silicate straight wheels, tapered wheels, and shapes other than those known as cup and cylinder wheels, which are used on bench floor, swing-frame and other machines for rough grinding. Speeds exceeding 5,000 ft. may be used upon recommendation of the wheel manufacturers, but in no case shall a speed of 6,500 peripheral feet be exceeded.

A wheel used in wet grinding shall not be allowed to stand partly immersed in the water. The water-soaked portion may throw the wheel dangerously out of balance.

Work shall not be forced against a cold wheel, but applied gradually, giving the wheel an opportunity to warm and thereby eliminate possible breakage. This applies to starting work in the morning in grinding rooms which are not heated in winter, and to new wheels which have been stored in a cold place.

<sup>1</sup> Copies of this report may be obtained from the A. S. M. E. by mentioning its title, "Safety Code for the Use and Care of Abrasive Wheels," and inclosing 10c. with the request.

# The Small-Shop Grinder

By JOHN H. VAN DEVENTER

*SYNOPSIS*—Machine grinding is not by any means restricted to large shops. It is true that the average small shop cannot afford to install a specialized machine with a small range of work for this purpose, but it should investigate the use of grinders of the universal type having a broad range. In this article the problem is attacked from the small-shop angle, and the causes and remedies of common grinding troubles are given.

The small-shop man does not ordinarily make his acquaintance with the art of grinding on what is called a "grinder." His introduction to this method of removing metal comes by way of a casting snagger, such as was described in "The Small-Shop Grinding Wheel," on

much like work. The grinder has no such notions about the matter, however, and will tackle the roughest job with the same degree of self-confidence that it displays on going over a glasslike surface. One good way to look at the grinder is as a filing and polishing machine, a device that will do the finishing much more quickly and with less need of skill than is required to manipulate the file and emery cloth.

"I don't need a grinder in my shop," says Bill Jones; "my lots are too small. I seldom have more than six like pieces going through the shop at the same time." By the same token, as the Irishman would say, Bill doesn't need a lathe or any other tool in his shop; for having such small lots, he should hog out the work with vise and cold chisel. You will find someone able to advance the most plausible objections against the use of any improvement that ever was invented, and the old

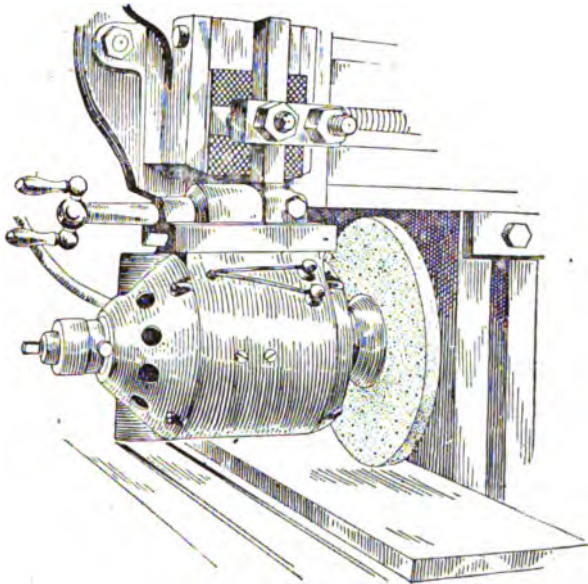

FIG. 1. SURFACE-GRINDING ATTACHMENT APPLIED TO THE PLANER

page 14 of this volume. This acquaintanceship broadens out through experience with various improvised grinding devices, which are applied at various times to each machine in the shop, from the engine lathe to the planer, usually with more or less unsatisfactory results. Finally comes the ultimate achievement—the purchase of a "tool grinder"—which usually accompanies the advent of the first miller. In the majority of small shops the owner "guesses" that this is as far as it is safe to go in the installation of grinding equipment. Whether this is a good or a bad guess depends greatly on the kind of work that is being done, but I venture to say that it is a bad guess in a great many cases.

One of the wrong notions of grinding is that its object is only to obtain a fine, smooth, accurate job. In 75 per cent. of the large shops that finish work by this means the compelling object is not the fine finish so much as the reduction in cost that can be obtained over the old method of finishing by fussing with fine cuts and a file. Lathe hands will not start to file on a shaft that is left full of grooves from a roughing cut—it is too

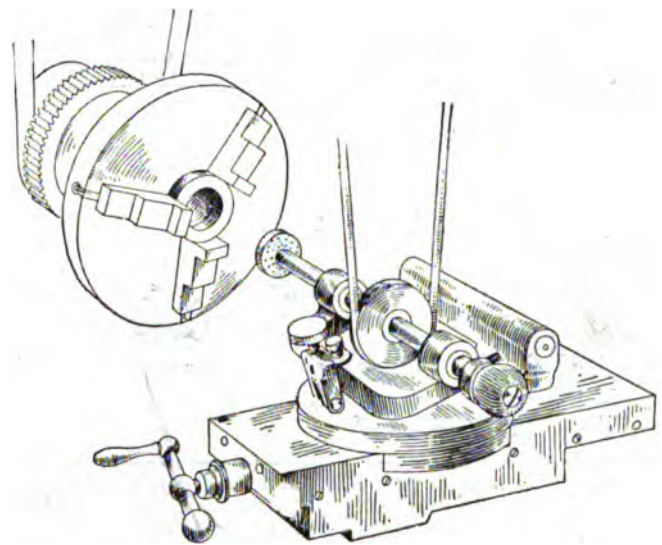

FIG. 2. TRAVERSE SPINDLE GRINDER ATTACHED TO THE ENGINE LATHE

excuse of "small lots" is a standby in the shop where progressiveness has taken a back seat in favor of precedence and habit.

It is easier to set up a grinder for an average job than to get a lathe ready for business, and the time saved even on one piece will often overbalance the setting-up time of the additional machine. Work that is similar, such as grinding shafts of various lengths, can be handled with the same set-up simply by moving the tailstock and obtaining a suitable work speed. Where there's a will there's a way; and where a way is found, nine times in ten there is profit also discovered.

The small shop that wishes to cut its eye teeth on the subject of grinding, at a minimum of expense, may do so by means of a tool-post grinder similar to that shown in Fig. 1. The advent of a small and durable electric motor makes this arrangement practical, as it dispenses with long overhead pulleys and traveling belts. An outfit of this kind will convert almost any machine tool into a grinder of sorts. In the illustration, Fig. 1, it is shown applied to a job of surface grinding, in

## MAKING SMALL SHOPS PROFITABLE

which a planer table is used to traverse the work and the planer head to crossfeed the wheel. Such a device cannot be expected to do the work of a machine especially designed for grinding. For one reason, the bearings are less rigid and will in time get loose; but if they are kept in first-class condition and too heavy cutting is not attempted, this tool-post grinder will answer the

the double purpose of grinding the lathe *tools* and cutting down the time otherwise wasted in walking to and from the regular tool-grinding wheel.

For a more accurate class of work the traverse-spindle grinder, shown in Fig. 2, is applied to lathes or millers with satisfactory results. The accuracy of the grinding, assuming that the fixture is in good condition, depends

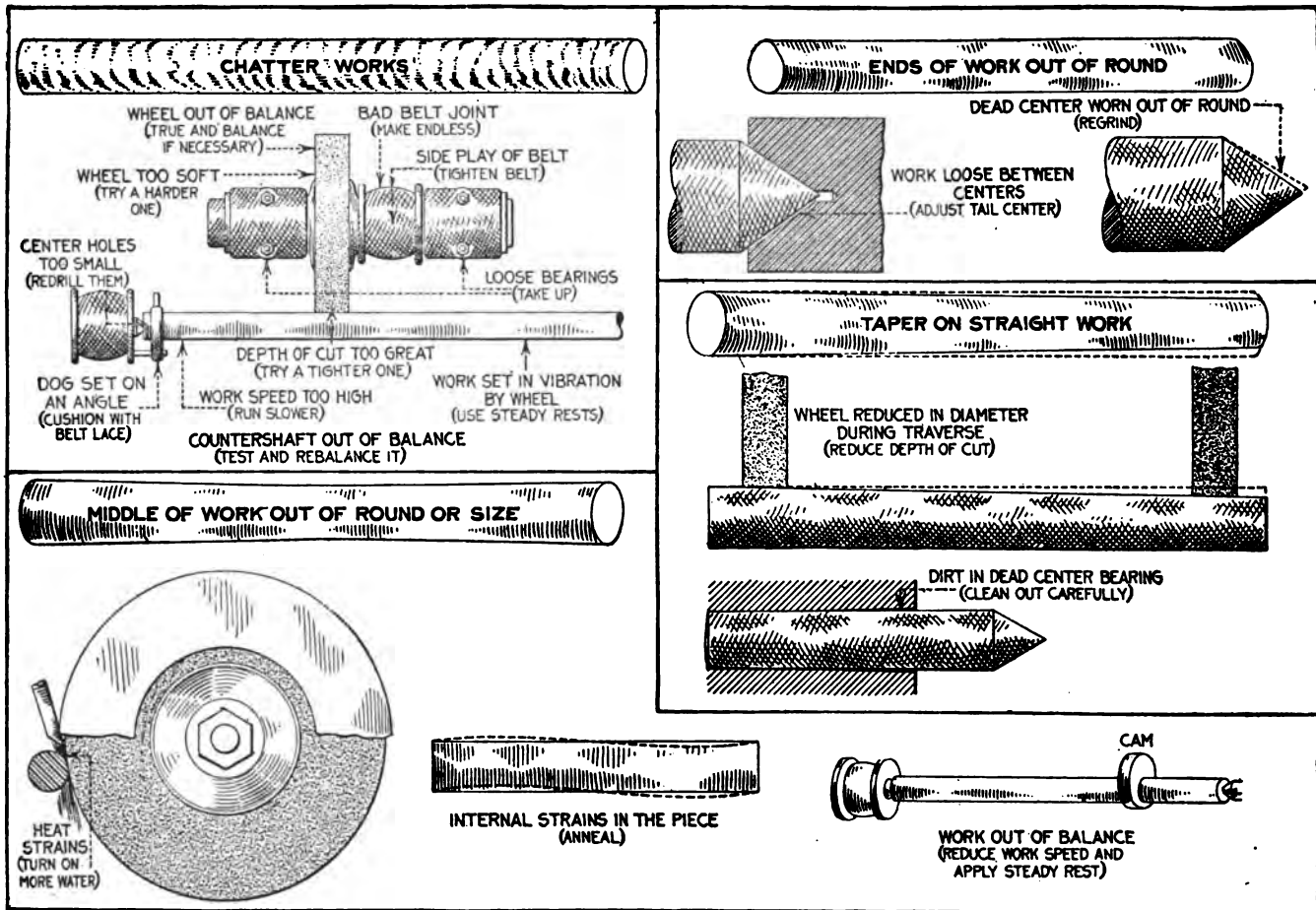

FIG. 3. CAUSES AND REMEDIES FOR MANY OF THE COMMON GRINDING TROUBLES MET IN BOTH SMALL AND LARGE SHOPS

purpose on the occasional job that cannot be handled by any other means. A grinder of this same type does excellent work in the lathe, if the precautions necessary to be followed in doing the same kind of work on a regular grinder are observed.

In many shops it is considered sufficient to stick the motor-driven grinding wheel in the tool post, put long slender work between centers and start to cut. In such cases it is usual to run the work speed well beyond the limit required for turning the same diameter, and also to use a hard close-grained wheel. When the job is finished, the boss wants to know who has been hammering at the shaft and has put in all the flat spots that are plentifully distributed over the surface of the work. A much softer wheel, a work speed one-third that required for a high-speed tool cutting on similar material and the use of back rests supporting the work from the back and from beneath on shock-absorbing wooden blocks will give quite different results.

A portable grinder of this kind can be used all around the shop. On the miller it will grind a fresh edge on cutters without removing them from the spindle; and when no other pressing use can be found, it can be bolted to the vacant end of the lathe bed and made available for

solely on the truth of the headstock or miller spindle by which the piece to be ground is rotated. An outfit of the kind shown is inexpensive and will handle the most accurate work. It is driven from overhead, usually by means of a drum pulley for this purpose, unless a small motor equipped with a driving pulley is mounted on the same slide.

One of the peculiar things about a traverse-spindle grinder that its operator must learn by experience is that the bearings are not in proper condition unless they run hot. If they do not, it is a sign that they are too loose for an accurate grinding job to be obtained. When you can rest your finger with comfort on the bearings of a contrivance of this kind, there is something the matter with it!

A grinding device of this simple and inexpensive type is suitable, not only for internal work, but also for angular and external work, since it can be swiveled about to any angle. In spite of its apparent lightness and the small dimensions of its spindle and bearings it will handle a very respectable cut in hardened steel.

The universal grinder presents itself as the next step in advance for the small-shop man who has outgrown

## THE SMALL-SHOP GRINDER

the use of the foregoing expedients. It is true that a machine of this kind costs considerably more than a simple tool grinder that may fill the bill for some time after its purchase. On the other hand, the range of work of a universal machine is so great that this must be taken into consideration and weighed as a part of the value received per dollar expended. A machine that costs \$800 and that is capable of earning \$8,000 during its life of usefulness is a much better investment than one that costs but \$200 and can earn \$1,000. In the case of the universal grinder you have as an asset its capability of handling commercial grinding, not as rapidly, of course, as it could be done on a plain machine of the same capacity, but fast enough to bring in a good profit. Such a machine should always be equipped for wet grinding.

This type of tool will handle not only all the grinding requirements of the small-shop tools and cutters, but also its commercial precision grinding—internal, external and angular—and a good range of commercial cylindrical and taper grinding in addition. In the average small shop it will be a long while before the demands for commercial work on a machine of this sort exceed its capacity in spare time. When such a time does arrive, it will be sufficiently soon to investigate the plain grinder as a means of handling this work.

### WET OR DRY GRINDING

The question of "wet or dry" is an absorbing one to the citizens of many of our states, where the matter is eventually settled by ballot. When it comes to grinding, opinion is more unanimous and is quite in favor of "wet." The use of a lubricant, or rather "coolant," on the grinder helps to make quick time and to give a smooth job, but its main purpose is to prevent the distortion that would otherwise occur, due to heating. When you consider that the chips torn from the work in grinding are raised to a temperature corresponding to the welding point of steel, the subject of temperature and the need of a cooling fluid take on a new importance. Oftentimes the water attachment is dispensed with as being a mussy contraption, a green hand finding that he needs a bathing suit more than a micrometer to help him navigate a grinder. This is all wrong and unnecessary; for if the stream is properly directed against the work, there will be absolutely no splash.

Among the things to keep in mind in operating a grinder is to use work surface speeds ranging from 25 to 35 ft. per min. when roughing, and 25 per cent. faster for finishing. As soft a wheel as possible should be used for the job, and the traverse per revolution should be between five-eighths and seven-eighths of the wheel face, in order to prevent wearing away its edges.

Some of the most common grinder troubles are represented in Fig. 3, which gives their causes and also the remedies to be applied in getting rid of them. They are included in this article, not to dishearten one who is contemplating the use of the grinder, but as a help for those who already have such machines. The former must remember that even in a foundry there are forty-seven ways of making a bad casting and that the comparatively few causes of trouble on grinders are really a recommendation for this type of machine.

## A Handy Clip for Hanging Wet Blueprints

By E. H. GIBSON

Draftsmen will agree that the market has little to offer in the way of a convenient device for hanging blueprints to dry. Except in the case of such drafting rooms as are equipped with elaborate drying and ironing machines, little consideration is given to the

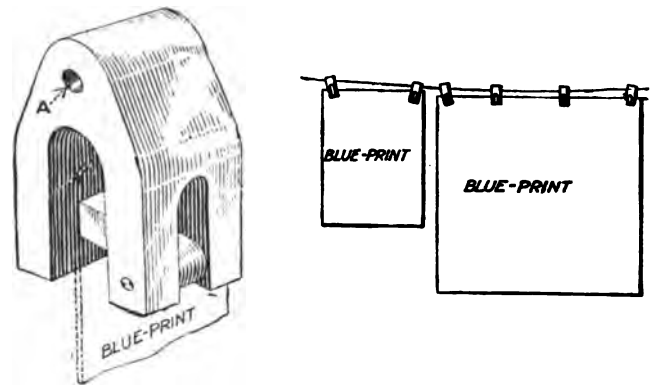

WOOD CLIP FOR HANGING BLUEPRINTS

matter, the problem usually being left to the blueprint boy, who hangs them to dry on lines and sticks in much the same manner as the first blueprint on earth was dried. Prints dried by this primitive method are wrinkled and present an untidy appearance in general even before being used; but we have learned to accept this condition as a matter of course where there is no ironing machine.

### A WOODEN BLUEPRINT CLIP

The illustration shows a home-made blueprint clip which the writer has found to answer the requirements satisfactorily. It is made of wood and consists of a body having a large open slot in one end and a trigger hinged at right angles to this slot. The trigger must work freely in order that it may fall into place of its own weight. The length of the trigger must be so calculated that the outer end strikes the opposite side of the slot at a point slightly above the center line. A small nail or wire serves as a hinge for the trigger. A hole is made in the body, as at A, and a number of the clips, depending on requirements, are strung on a line. At least two clips must be used to hang one blueprint, but three or four should be used for the larger-sized sheets to make them hang smoothly. The hole should be made no larger than necessary, so that if the clip is pulled to an oblique position it causes a binding action. This feature is useful for the purpose of stretching the blueprints and making them hang smoothly. The clips in the corners of the blueprints shown are used in this manner. These clips require no manipulation except to slide them into place on the line, which can easily be done while holding the wet blueprint in the hands. Blueprints dried on these clips are as smooth as if ironed.

# Knurling in the Small Shop

BY JOHN H. VAN DEVENTER

**SYNOPSIS**—This article describes the methods of marking and using knurls. Cut, rolled and fancy knurls are described, and methods are given for using them on all the machines found in the small shop.

Every machinist and almost every apprentice has in his tool box one or more knurls that he is quite sure beat anything any other man ever made. Also, very good knurls in a large assortment of patterns may be bought ready to mount in a holder and use. With this prolific source of supply it may be asked why the small-shop man should be interested in knowing how to make knurls. But a small-shop man must be posted on many things that the large-shop man does not need to know, for in the course of his varied and exciting existence

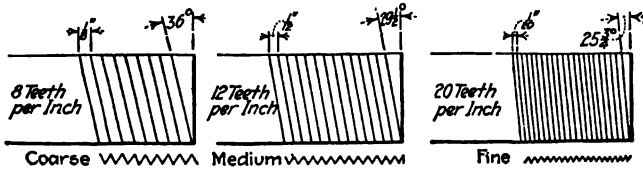

FIG. 1. ANGLES FOR CUTTING COARSE, MEDIUM AND FINE SPIRAL KNURLS

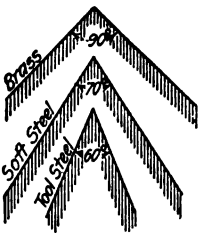

FIG. 2. ANGLES FOR TEETH

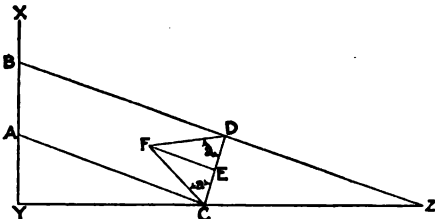

FIG. 3. OBTAINING THE DEPTH OF KNURLED TEETH

he rubs up against circumstances that are quite outside of his special line. And also, a knowledge of how things are made does not interfere with knowing how to employ them.

Knurling is one branch of the process by which impressions are transferred from one material to another by rolling. It is in the same class as thread rolling and the making of index dials by the rolling process. Knurling is applied to both flat and curved surfaces, and the tool itself may be either flat or curved. Where the work is flat, the knurl is circular; but when the work is circular, the knurl may be either circular or flat. An example of circular work and flat tool is the method of knurling work held in lathe centers by allowing a coarse file to "float" upon it.

I will pass up the ornamental knurls for the present and speak of the kind that will be found of greatest service in small shops—the straight and spiral patterns. These are originally produced by cutting what is known as a "master knurl." From this master, which is the same as the impression desired on the work, other knurls are produced by rolling and are used in the shop, the master being kept for reproducing purposes. Sometimes

this process is carried back and forth many times, until the offspring lose their family resemblance. The great-grandchild of a master knurl will not produce as good work as his grand-daddy, and for this reason the best knurling is procured directly from machine-cut knurls without the use of masters.

The knurl has been called a "putting-on tool." It increases the diameter of the work, because metal is forced up between the knurl teeth. Knurls and thread rolls are similar in their action, knurling being simply a case of rolling multiple threads. The stock diameter increases in knurling as it does in thread milling and in both cases may be figured roughly as equal to the depth of the tooth produced, this being the same as saying that the knurl tooth goes down halfway into the stock and forces the stock halfway up into itself. The coarser the pitch of the teeth of the knurl the deeper

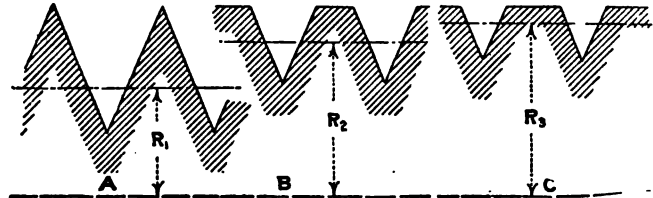

FIG. 4. VARYING THE DEPTH OF CUT GIVES SOME RANGE AS TO THE NUMBER OF TOOTH IMPRESSIONS

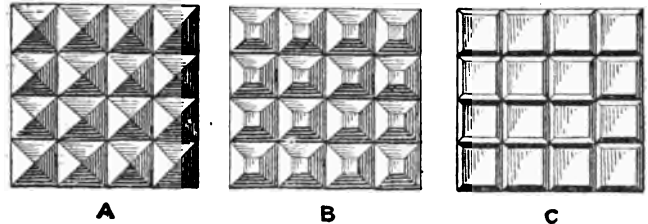

FIG. 5. PATTERNS OBTAINED WITH DIAMOND KNURLS BY VARYING THE DEPTH OF CUT

these teeth become. The result is that more pressure must be brought against the work in order to raise the impression. For straight and spiral knurls it is well not to have less than eight teeth per inch for the coarsest pitch.

In a spiral knurl the finer the pitch the less may be the angle made with the axis of the knurl. This is shown in Fig. 1, which gives pitch and angles for coarse, medium and fine spiral knurls. The greater this spiral angle becomes the less is the "bite" taken across the face of the knurl, and it is for this reason that this angle is made greater on the coarse pitches. It also follows that a finer feed must be employed on coarse-pitch knurls than on fine-pitch ones, in order to get full tooth impressions.

The angle of the knurl tooth varies with the hardness of the material to be knurled. Various angles are illustrated in Fig. 2; they are suitable for brass, soft steel and tool steel. It also follows that the harder the material to be knurled the finer should be the pitch of the knurl, so that a sharp tooth angle and a fine pitch usually go together. This distinction, so far as hardness is concerned, is an important one.



## KNURLING IN THE SMALL SHOP

Having the circular pitch of a spiral knurl and the number of teeth, the diameter is found by multiplying the circular pitch by the number of teeth. A simple way of obtaining the tooth depth is given in Fig. 3. *XY* and *YG* are laid out at right angles, and points *A* and *B* are laid out on line *XY* at a distance apart corresponding to the circular pitch of the knurl. Through these points lines *AC* and *BG* are drawn representing the teeth and making an angle with the line *YZ* equal to the angle of the spiral knurl. The line *CB* is drawn perpendicular to the line *AC*, and the lines *CF* and *BF* are drawn at an angle *A* equal to one-half of 180 deg. minus the tooth angle as shown in Fig. 2. In other

words, for tool steel the angle *A* will be  $\frac{180 - 60}{2} = 60$  deg. For brass the angle *A* will be 45 deg. and for soft steel 55 deg. The height of the triangle thus formed, represented by the line *EF*, will be the tooth

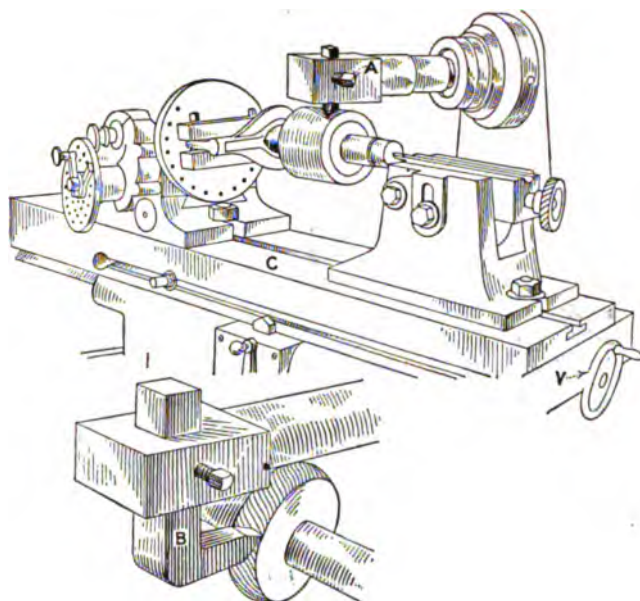

FIG. 6. A SIMPLE ARRANGEMENT FOR MAKING A SPIRAL KNURL ON THE MILLER

depth. If this diagram is laid out on paper ten times full size, the depth may be read off in thousandths of an inch by means of a scale reading in hundredths.

These calculations apply to the diameter of the knurl itself, but a similar calculation is not often necessary for the diameter of stock, although in a case of coarse-pitch knurls an attempt must be made to get the correct stock diameter to avoid tooth impressions overlapping.

This diameter may be "found" more easily than it can be "calculated." The thing to do is to leave the stock a trifle large and reduce it until the tooth impressions come out with no overlapping. On fine-tooth knurls this is not necessary, for a little more or less pressure when the knurl gets to its depth will bring satisfactory results. If you have but one piece to knurl, it is better to use a fine knurl and not have to make experiments on the diameter; but if a large number of pieces are to be knurled in the screw machine, the time spent in experimenting with one of them will not be of much importance.

Varying the depth of the cut gives a slight range as to number of tooth impressions, as shown in Fig. 4, and

also produces a variation in pattern in the case of diamond knurls, as may be seen in Fig. 5. Full-depth knurling produces the pattern at *A*, Fig. 5, while *B* and *C* are modifications corresponding to the depths at *B* and *C*, Fig. 4. If the object of knurling is to provide a grip for the hand, as upon a chuck body, knurling to part depth is advisable, since it gives sufficient roughness to enable the piece to be gripped without having the sharpness of full-depth knurling, which is likely to hurt the hand.

Straight-tooth knurls are easily cut on a lathe by holding the blank between centers and indexing on the back gears. The tool is held horizontally in the tool post, and the carriage is moved back and forth by hand, thus planing the teeth. Spiral knurls are cut in a similar way on a universal miller having index centers. The dividing head is geared up for the correct lead of the spiral, and a single-point

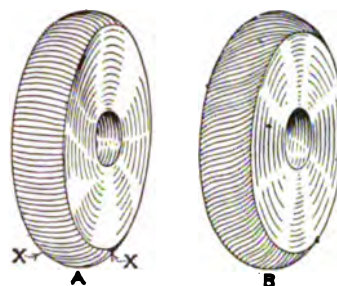

FIG. 7. PLAIN AND SPIRAL ROUND KNURLING

tool shaped to the angle of the knurled tooth is held in a fly-cutter holder such as is illustrated at *A* in Fig. 6. For ordinary work it is not necessary to rotate this fly-cutter; it is sufficient to hold it in a vertical position and plane the grooves by moving the table back and forth by hand, the dividing head with its gears taking care of the angular rotation of the work. When cut knurls are required in quantities, it is best to have a milling cutter.

Surfaces formed with a radius may be knurled as shown at *A* and *B* in Fig. 7, the first being an example of convex straight and the second of spiral convex knurling. The radius of the rounding on a concave knurl, which is to produce a pattern on convex work

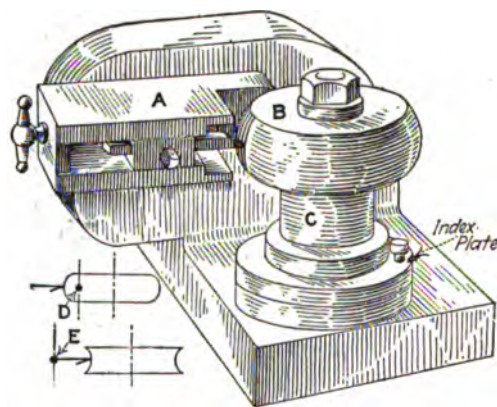

FIG. 8. ARRANGEMENT FOR CUTTING CONCAVE AND CONVEX MASTER KNURLS

of this kind, must be slightly greater than the radius of the piece to be knurled, in order to prevent tearing of the work at the corners marked *X* in the illustration. A knurl for work of this sort is produced on a simple swivel tool-holding device, Fig. 8, the work being mounted on an index center and the single-point tool being swung on a radius across the face of the knurled blank. The point *D* shows the position of the pivot in producing a convex knurl, and *E* shows the position of the pivot when making a concave knurl. Both concave and

## MAKING SMALL SHOPS PROFITABLE

convex knurls may be produced on the same device by shifting the position of the index center and of the tool with relation to the pivot pin.

Spiral convex knurling, such as shown at *B*, gives a very pleasing appearance, but requires more complicated arrangements for making the knurl. The universal miller is set up as for the straight-faced spiral knurl in Fig. 6, except that the tool is placed horizontally as at *B*. A templet is provided having a radius equal to that of the knurl, with the cross-feed, and this is followed while the longitudinal feed produces the spiral. When a knurl is required for a pattern like that in Fig. 9, in which the diameter



FIG. 9. HOLDER AND SPACING COLLARS FOR "BUILT-UP" KNURL

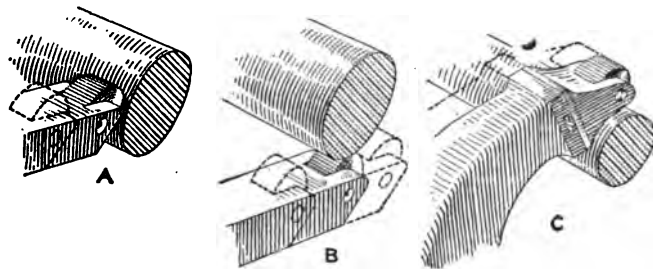

FIG. 10. GENERAL WAYS OF KNURLING ROUND STOCK ON SCREW MACHINE AND AUTOMATICS

of the various knurled portions vary, it is a good scheme to make a "built-up" knurl with one roller for each portion and spacing collars between. The separate knurls are thus free to rotate at different speeds to suit the diameter of the work. Even on work of one diameter, in which three or four spots are to be knurled in this way, a built-up knurl will often prove a good investment, as it enables the pattern to be changed and a broken tooth does not cause as much loss as it would in the case of a solid knurl. There is a variety of ways to knurl in the hand screw machine and automatics. Sometimes the knurl is mounted on the cross-slide and is advanced directly in the work on the center line, as illustrated at *A*, Fig. 10, feeding in to the depth of the tooth and remaining a moment before being withdrawn. Another plan is to pass the knurl under the work, as at *B*, allowing it to rest a moment on the center line so that the tooth impressions become fully developed. Another plan makes use of the swinging arm, as at *C*, otherwise being similar in principle to *A*. Knurling

with a box tool having roller backrests is shown at *B*. The knurl *E*, Fig. 10, is swung in toward the work by means of the eccentric *F*, and the plain rollers *G* running on each side of the knurled portion serve as backrests and balance the cut.

In connection with backresting, the location of the knurls and their number have an important effect on the strain produced in the work. The most common arrangement is illustrated at *A*, two knurls being held against one side of the work, resulting in a heavy unbalanced pressure. When one knurl is placed diametrically opposite the other on two opposite sides of the shaft, conditions are much better, although there still is a tendency for the rollers to ride up on the work in the direction of rotation. The scheme shown at *C* is the best of all, two rollers being mounted on one side of the shaft and one on the other, all tendency for rollers to ride up on the work being eliminated.

Ornamental knurling is an art not often practiced in the small shop. Artistic results can be obtained by knurls made as shown in Fig. 12, of which the result pictured at *A* is an example. The first step is to put in the ground lines, which consist of straight, fine-tooth knurling running across the piece, as at *B*. Punches are

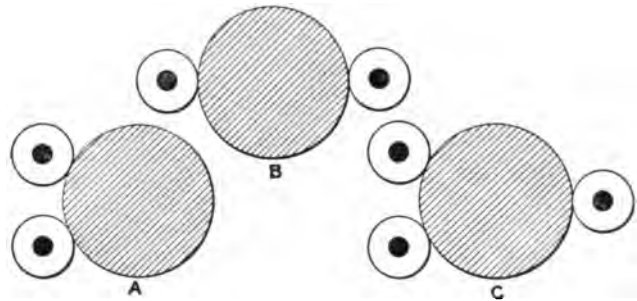

FIG. 11. GOOD, BETTER AND BEST COMBINATIONS

made carrying one unit of the figure, such as shown at *C* and *D*. The work is then held upon the arbor of an index head, as at *E*, and the pattern is stamped by means of a hardened punch sliding in a fixed guide *H*. Doing this work by hand is a delicate job, requiring a great deal of skill in giving the blow required to make the impression. A better way is to rig up a light drop that insures the same weight of blow for each repetition of the figure. The fine-ground lines at *B* are not put in simply for ornamental effect, but to serve the purpose of gearing the knurl to the work. They are quite necessary on ornamental designs of this kind, which are not positively driven, but in which the knurl depends for its rotation and registry upon its contact with the work.

Another way to repeat a design of this sort is by rolling. A hob carrying a single impression is applied to the work by gears having teeth so figured that the hob is brought into contact with the surface of the work at a different place each revolution, until the entire surface has been covered with impressions. For example, if 40 impressions are desired on a circumference, these may be obtained by using gears having 40 and 39 teeth respectively, the former connected to the blank and the latter to the hob.

In making a knurl, use tool steel having a carbon content between 90 to 110 points. Make the hole for the pin on which the knurl is to rotate small in diameter

# KNURLING IN THE SMALL SHOP

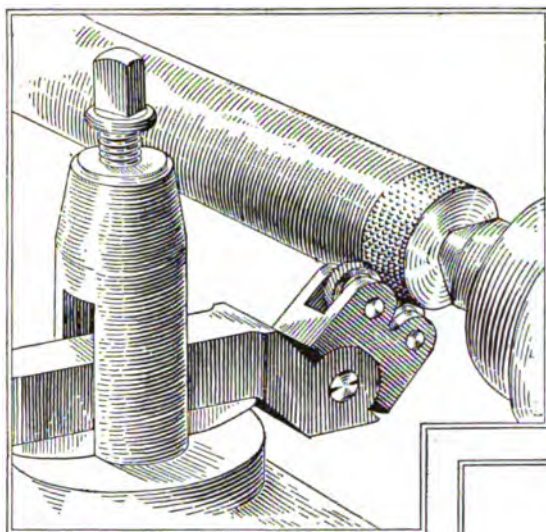

IN THE ENGINE LATHE

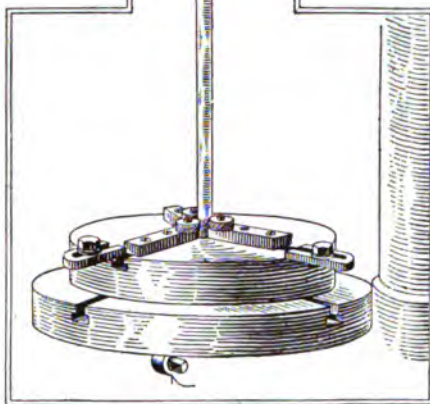
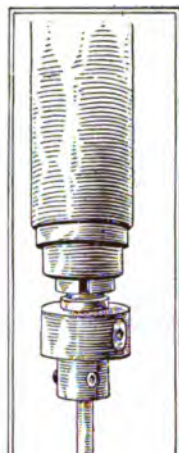

ON THE DRILLING MACHINE

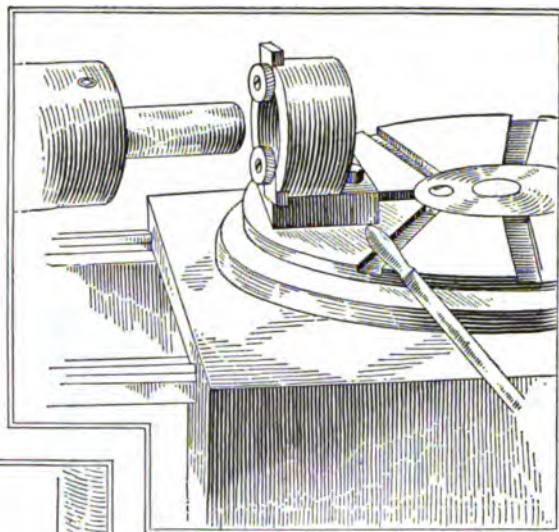

ON THE SCREW MACHINE

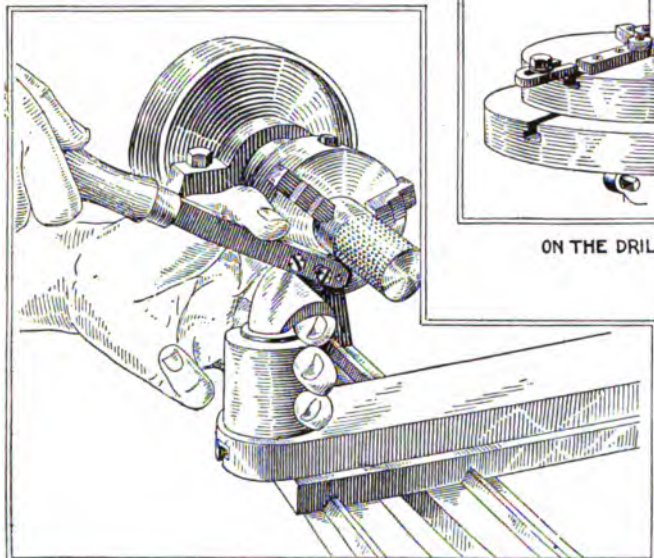

ON THE SPEED LATHE

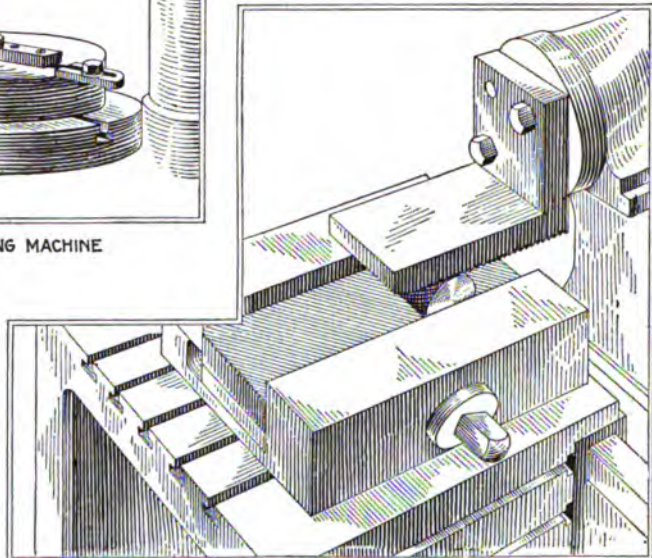

IN THE SHAPER

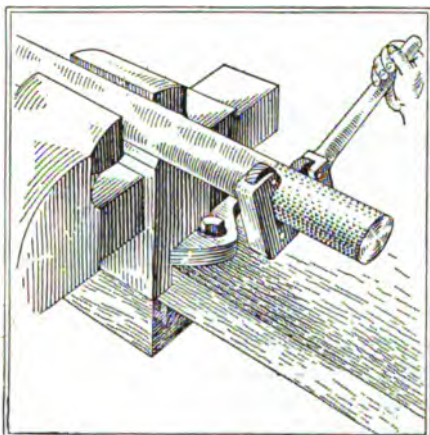

IN THE VISE

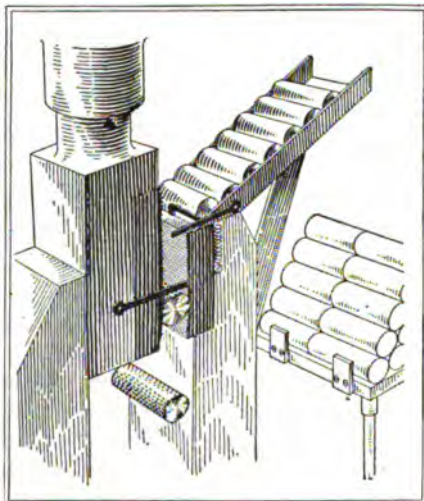

ON THE PRESS OR SLOTTER

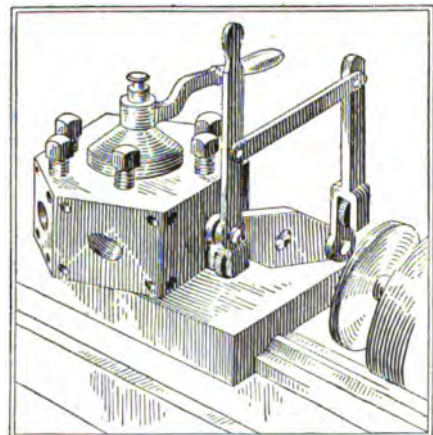

ON THE CHUCKING LATHE

FIG. 17. KNURLING DONE ON ALL THE TOOLS IN THE SMALL SHOP

## MAKING SMALL SHOPS PROFITABLE

in order to reduce friction, and leave a collar on the side of the knurl for the same purpose. For a fancy knurl of complicated design it is best to use nonshrinking steel. Harden at a temperature corresponding to its carbon contents, as described on page 31, applying file cutters' paste to the knurl before heating. This is made up according to the following formula: Pulverized charred leather, 1 lb.; fine family flour, 1½ lb.; table

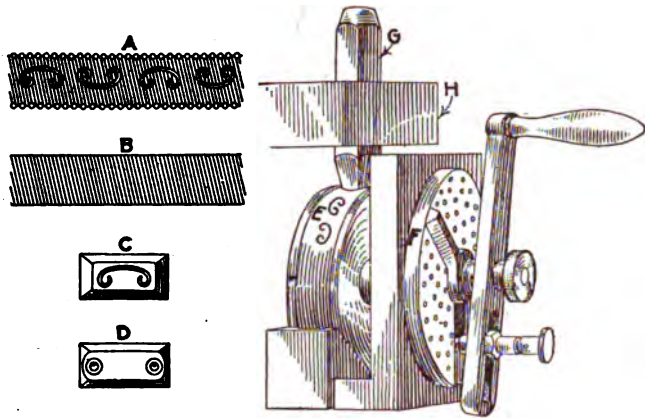

FIG. 12. ONE METHOD OF PRODUCING AN ORNAMENTAL MASTER KNURL

salt, 2 lb. The charred leather should pass through a 45-mesh screen. The ingredients of this paste are mixed dry, after which water is added slowly and it is kneaded to prevent lumps from forming. It is used at the consistency of thin molasses, is applied to the knurl with a brush and allowed to dry before the piece is heated. After heating, the knurl is quenched in water and then drawn to a color between dark yellow and yellow brown.

Some 20 years ago Edward Board, of Philadelphia, devised the triple adjustable knurl seen in Fig. 13. It combines the balance of forces described at C, Fig. 11, and has the good feature of being adjustable into the

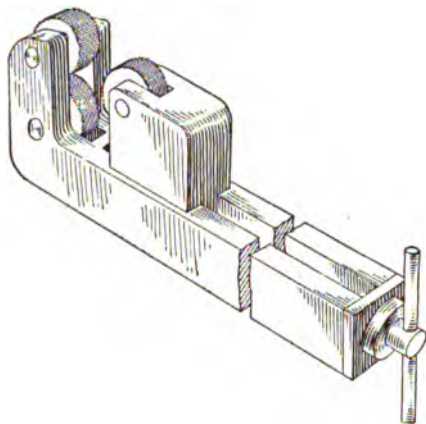

FIG. 13. ADJUSTABLE TRIPLE KNURL FOR HAND OR LATHE KNURLING

bargain. Mr. Board says that all small-shop owners are welcome to this idea, which is not patented, and which I can say from observation is a mighty good one for either hand or tool-post knurling.

One way to produce spiral knurling is shown in Fig. 14. In this case a straight knurl is inclined at an angle with the axis of the work and fed along by the tool carriage. This scheme is especially good for producing deep spiral knurling, as the teeth are cut to their full depth at the center of the knurl and there is no tendency

to break off the tooth corners. This advantage is offset by having to use a comparatively slow feed, since the band produced by a single rotation of the shaft is much narrower than would be produced by the knurl held parallel with the axis, as is clearly indicated at A, Fig. 14.

An adaptation of this principle for double spiral knurling is given in Fig. 15. In this case we have

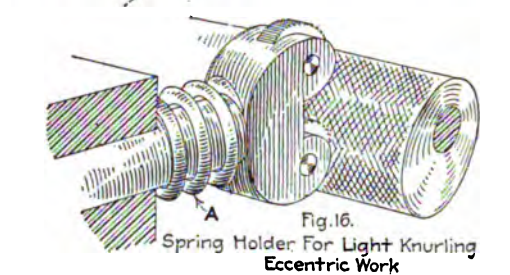
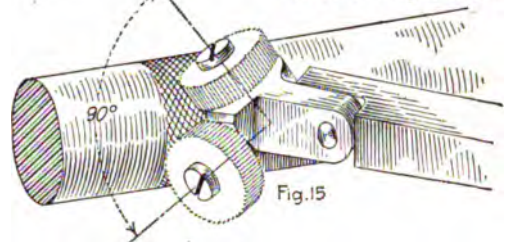
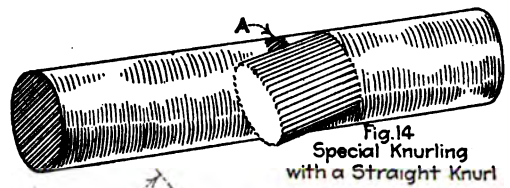

FIGS. 14, 15 AND 16. SPECIAL APPLICATIONS OF KNURLS

two straight knurls, both of them mounted and held at angles to the axis of the shaft and at right angles with respect to each other. The result is a diamond knurling, similar to that which would be made with a single spiral knurl held parallel to the axis. Deeper impressions of coarse pitches can be made with a knurl of this kind than with a spiral diamond knurl.

A scheme that has been used for knurling eccentrics is illustrated in Fig. 16. The tools are kept in contact with the work by means of the spring A, which must be sufficiently stiff to force the knurls into the work before the spring yields.

Sometimes knurled effects are produced not by knurling, but by stamping. An illustration of this is seen in Fig.

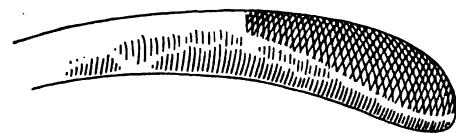

FIG. 17. KNURLED EFFECTS ARE PRODUCED BY STAMPING

17, which represents the roughening of one of a pair of plier handles by this simple means.

Although there is as a rule a machine best fitted for each kind of work to be done, this does not seem to hold true when it comes to knurling. The illustrations in Fig. 18 show how knurling may be accomplished in every machine usually found in the small shop and also by hand in the vise. If all work was subjected to such flexibility of handling, the small-shop man's trouble would be over!

# Screw Threads in Small Shops

BY JOHN H. VAN DEVENTER

**SYNOPSIS**—Every shop has much to do with screw threads, especially in their broadest application as means for holding machine parts together. Many shops lose money through not being "on to the curves" of the simple but sometimes aggravating machine elements. This article deals with various methods of screw cutting applicable to small shops.

When you buy a suit of clothes, you do not give a thought to the unseen thread that holds the pieces of cloth together. But let this unseen thread fail to do its duty in some important seam, and it becomes to you momentarily the most important thing in the world!

There is a close analogy between threads and threads, as applied in the textile and mechanical fields. Both of them hold things together, both have been given the same

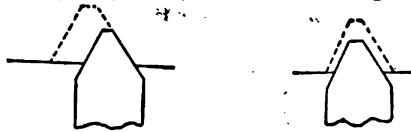

FIG. 1. CUTTING ONE SIDE OF THE THREAD SPACE IS BETTER THAN CUTTING BOTH

name; and take either away from its field of application and you put civilization back many centuries.

History does not give us a description of the man who first cut a screw thread, so we are at a loss to know whether this thread was cut to the United States standard, the sharp V-standard, the Whitworth standard, the British Association standard, the French metric standard, the International standard, the Löwenherz standard, the acme standard, the Cadillac standard, the square standard, the Briggs pipe standard, the British pipe standard, the hose standard, the British standard fine screw, the Society of Automobile Engineers standard, the American Society of Mechanical Engineers machine-screw standard, the old standard of machine screws, the gas-fixture standard or the Cycle Engineers standard.

Being a pioneer has its advantages, one of them being that you do not have such a conglomeration of established standards to worry about and choose from. To think of the brain energy that has followed the convolutions of all of these different standard screw threads makes one as dizzy as Mark Twain's "drop of whiskey running down a corkscrew." Picture to yourself the numerous conclaves of the wise men of all the nations necessary to establish such an unholy medley of standards, the fuming and fussing and evaporation of brain vapor that were required to invent, establish and sort these 57 varieties! National societies have sat in discussion upon it, universities have deliberated upon it, corporations have investigated it, and in fact, taken all-in-all, this simple mechanical element has had almost as much public discussion as any of the "big" issues of the day.

The regrettable thing about it is that with all this thought, talk and action, while we have standards giving the dimensions, angles and proportions of screw threads, with a few exceptions we have not yet had laid down what

is more important for the shopman—the *limits* defining these standards. One of the notable exceptions to this is the A. S. M. E. standard for machine screws, which has been adopted by all tap and die makers.

While there are so many standards to choose from, the small-shop man need not be in a dilemma about which one to take. Outside of repair jobs, which call for special threads, nine-tenths of his work is or should be restricted to the U. S. standard, and the other one-tenth which will call for a finer pitch, should be divided between the A. S. M. E. standard for machine screws for diameters under  $\frac{1}{2}$  in. and the S. A. E. standard for the fine-pitch threads between  $\frac{1}{2}$  and 1 in. There is no excuse for making special taps in the small shop, and the policy of sticking to these established standards will save money.

Do not attempt to hog repair business by using a special thread standard of your own, for nothing makes the user of a machine more angry than to find that some screw that has been lost or broken is a special one and must be replaced at the factory. You may lose a cent or two of profit by not having the repair order come to *you*, but you are likely to lose the customer's business if you adopt such a small and mean policy. And by all means steer clear of the V-thread. It is not as strong as the U. S. standard and is more easily damaged on account of its sharp edges. When the V-thread and the U. S. standard get together in a shop, trouble begins, especially when one tries to use a V-standard screw in connection with a U. S. standard nut. Nothing but main strength and the compressibility of metal save the day under such circumstances!

Before speaking of the accuracy and errors of screws, it is well to distinguish between the two main purposes for

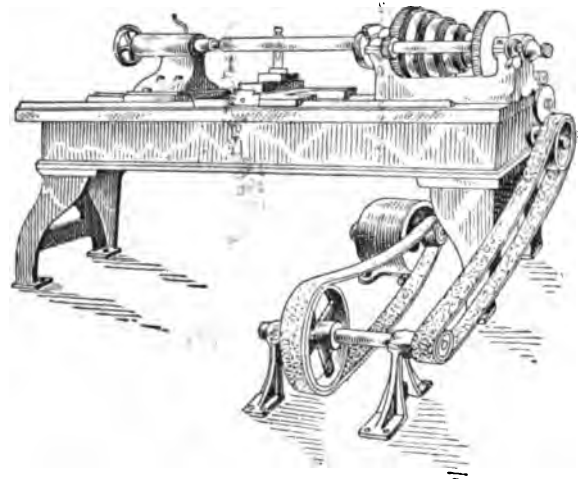

FIG. 2. RIGGING UP TO CUT A "QUICK" LEAD IN THE LATHE

which they are used: One class must be very accurate indeed, this comprising the lead screws, dividing screws and the like, which may be classed as "precision" screws. The broader application as fastenings, comprising bolts, studs, nuts, machine screws and the like, while they do not require the extreme precision of these former screws, must still be held to certain dimensions in order to reduce the shop owner's expense and the shop assembler's profanity, when it comes to putting things together.

## MAKING SMALL SHOPS PROFITABLE

In screw fastenings, errors of lead such as are ordinarily found in commercial taps and dies are not important, since the thickness of the tapped piece into which the screw is entered is ordinarily not greater than the diameter of the screw itself. There is small need to worry about slight errors of lead on this class of work, especially if the shop owner gives his taps and dies an accurate inspection after receiving them.

A great deal of tap wear and breakage can be eliminated from both small and large shops by the use of better judgment in the selection of tap-drill sizes. Size for size as compared with other tools the tap does a lot of work. The length of cutting edge in contact with the work in any tap is considerable. It is yanked through metal by main strength or driven through by an unfeeling machine, and in either case the cutting edges suffer accordingly, especially if the tap drill is small. In most places where screw threads are used for fastening pieces together the maximum strength of the thread is not required. It is merely a case of holding one piece of metal to another, and the strain which tends to separate them is not enough to stress the screw to anywhere near its safe limit.

Yet under these conditions you will find no distinction made in the shop as to the size of the tap drill used. In many such cases a drill is selected that is even smaller than the root diameter of the thread, which means that the tap must do the work of a reamer as well as its own. It has been shown that if the threads in a nut are made but 50 per cent. of the full depth of the standard thread, they are as strong as the bolt!

**TABLE OF TAP-DRILL SIZES, U.S.S.**  
(For thread depths equal to 50, 75 and 90 per cent. of full thread)

Diameter	No. of Threads	Tap Drill	Tap Drill	Tap Drill
		for 50 per Cent. Depth	for 75 per Cent. Depth	for 90 per Cent. Depth
1/4	20	7/32	13/64	No. 11† (3/16)
5/16	18	J* (1/16)	5/16	D* (3/8)
3/8	16	Q* (21/64)	7/16	N* (19/64)
7/16	14	29/64	29/64	T* (29/64)
1/2	13	29/64	29/64	Z* (19/32)
9/16	12	35/64	31/64	19/32
5/8	11	5/8	17/32	39/64
11/16	11	5/8	19/32	37/64
3/4	10	11/16	41/64	3/4
13/16	10	5/8	23/32	49/64
7/8	9	51/64	49/64	3/4
15/16	9	5/8	59/64	13/16
1	8	39/64	7/8	55/64
1 1/16	8	63/64	15/16	69/64
1 1/8	7	1 1/32	63/64	41/64
1 1/4	7	1 1/32	13/16	11/16
1 3/8	7	1 1/32	17/16	15/16
1 1/2	7	1 1/32	111/64	19/16
1 5/8	6	1 17/64	17/8	13/8
1 3/4	6	1 25/64	111/32	15/4
1 7/8	5 1/2	1 1/4	17/8	113/32
1 5/4	5	1 1/4	19/8	139/64
1 3/2	5	1 1/2	111/8	141/64
1 1/2	5	1 1/2	129/32	147/64

\* Letter-size drill; if not available, use size given in parenthesis. † Wire-size drill; if not available, use size given in parenthesis.

The relation between tap-drill size and the elbow grease required to drive a tap is not realized until you have pulled a 2 1/2-in. tap through 3 or 4 in. of steel. I had this experience during the early days of apprenticeship at a Middle Western tool works. The job was given to the newest apprentice, with the idea that while he and the shop helper were pulling their lungs out at opposite ends of a double-end tap wrench he would absorb the first principles of machine-tool building, which in those days was more sweat than science. Fortunately the pipe shop was not far removed, and more fortunately there was plenty of room all around the casting which was to be tapped, so that, before long, science came to the aid with two 14-ft. lengths of 1 1/2-in. pipe that reduced the pull and increased the walk.

But even so it was a slow walk, for the tap had been preceded by a drill that was scarcely larger than the root diameter of the threads and it took close to a day and a half to finish what might have been accomplished in an hour or two at most with equally good results, had the hole been drilled somewhat larger. Nothing on earth could have stripped those threads, I am sure, even had they been half-threads only, for that steel was the toughest material that ever escaped from a steel-foundry scrap heap!

The table of tap-drill sizes given here will enable the small-shop man to use judgment and save his taps. In no

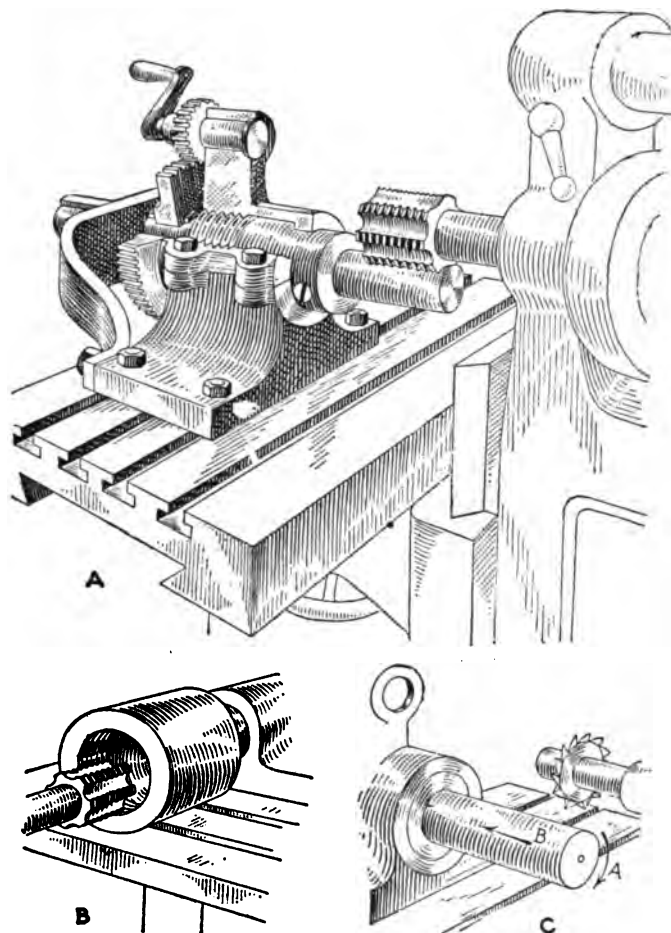

**FIG. 3. MILLING THREADS WITH A SINGLE CUTTER AND WITH MULTIPLE CUTTERS**

case should he use a tap drill smaller than 90 per cent. of the depth of the thread, such as is given in the third column. For machine tapping, a 75 per cent. depth is ample; and in fact if the hole is made smaller, tap breakage will be a considerable item. For ordinary screw fastenings where no great strain or pressure is brought against the parts, 50 per cent. of depth will answer the purpose except in cast iron. The speed of tapping is largely influenced by the selection of the tap-drill size and increases much faster than the percentage of full thread depth decreases.

Hand tapping should be looked upon as a very expensive way to do the work; in fact, it should be regarded as similar to the crude method of ratcheting a hole instead of machine drilling it. Even when a close fit is desired, the holes should first be machine tapped with an undersized tap and then retapped to size by hand. Retapping with a sizing tap is the only way in which a large number of tapped holes can be kept to a close standard of size, as has

## SCREW THREADS IN SMALL SHOPS

been discovered by those who have had experience in shell work. This is a natural thing to expect, as the shopman would scarcely think of using any other form tool but a tap for both roughing and finishing cuts, with the expectation of holding size. There is no reason why this cutting tool should be an exception to the rule, and shopmen are rapidly finding that it is not.

The only machine tapper available in small shops is quite likely to be the drilling machine. Even if this is not fitted with reversing gears, a tapping chuck can be obtained that is automatic in its action and that will start to back the tap as soon as the feed lever is raised. These tapping chucks are not only reliable, but are time savers, and no small shop can afford to be without one. When the work runs in large quantities of one or two tap sizes, it is time to consider a tapping machine. Some of these are very simple in construction, and in fact one of the most convenient I ever saw was a home-made affair in which a horizontal spindle was controlled by two friction gears, the tap going into the work when the operator pushed the piece against it and backing out with a fast reverse motion when he started to pull. A contrivance of this kind will tap an almost incredible number of holes without getting stiff in the joints, which is more than can be said for the average vise hand. Probably 90 per cent. of the screws used in the small shops are die cut. Like all female threads, those in dies are infernally hard to measure. The best test of the die is the work that it does; and its offspring being all of the male gender, one can readily measure and inspect them.

All threads come originally from the King of Machines, the engine lathe. One of the best kinks in cutting threads on a lathe with a single tool is that attributed to Professor Sweet, in which the compound rest is swiveled 30 deg., so that instead of feeding directly into the work and cutting on both sides of the thread the tool has a one-sided cut, as shown in Fig. 1. This scheme prevents torn threads and is not as widely used as it should be.

### SCREW CUTTING ON THE LATHE

While the lathe has the ability to develop a thread through its lead screw by means of a single-pointed tool, it is not by any means restricted to such high-grade but expensive kind of work. It will carry either a tap or a die and thus transform itself without protest into a tapping machine or a bolt cutter. And speaking of bolt cutters, some very pretty screw threads are produced on these machines, which are sometimes considered to be crude. Their work is not by any means restricted to threading rough bolts, however, and they can be applied for short feed screws such as are used in blacksmith drills and the

like, where the exact lead need not be held to close limits. A bolt cutter will produce just as finely finished threads as a screw machine, for in both cases the quality of the work and the lead depend upon the die, the machine simply being the means of making things go around and important mainly for driving power.

When the small-shop man gets up to leads of  $1\frac{1}{2}$  in. or over, he begins to have trouble with the feed works of his lathe. Such leads are not common on screw threads pure and simple, but are not infrequent on its close cousin, the worm, and on some multi-thread screws. In such cases change gears can be saved from breaking and the job may be made easier by rigging up as shown in Fig. 2, on the principle that there is always less strain involved in slowing down than in speeding up.

### ACCURATE SCREWS ON THE THREAD MILLER

Since the advent of the thread miller, the lathe with its single-point tool is not the only machine which can produce accurate screws. A positive lead is used in this milling process, the accuracy of the product, as far as lead is concerned, depending upon the accuracy of the miller lead screw, just as it does on the lead screw in lathe work. The thread miller has another advantage in being a semi-automatic machine and thus slicing off a large portion of the labor required to cut a screw. While a specialized machine of this type is possibly outside the range of most small shops, adaptations of the milling process are not. Some of these are shown in Fig. 3.

At A is an attachment rigged up on a plain miller of the knee and column type. The cutter is a plain grooved cutter and has no lead. The length of the cutter is equal to the length of the thread desired on the work, which is held in a fixture having a master screw of the same pitch as the cutter. One rotation of the work mills the entire length of thread and does it in about one-tenth the time that is required by any other method. This is a scheme that has been largely applied to milling internal threads in the base recesses of high-explosive shells where there is not room enough for a tap to clear, the recess at the bottom of the thread being just about equal to the width of one thread. This is shown at B in Fig. 3.

### MILLING THREADS WITH A SINGLE CUTTER

It is not necessary to mill threads with a multiple cutter, for they can be handled as shown at C, in which a cutter is used having the form of a single tooth space. The work is held and moved as in the previous case. This is the principle employed in thread milling, except that the cutter is moved instead of the work. A more accurate thread can be produced by a single cutter than by a multiple cutter, owing to the changes in form and pitch which the latter undergoes in hardening. Any one of these three schemes may come in handy in a small shop when there is a quantity of work to be done at low cost and yet at a profit.

Even the vertical drilling machine may be made to cut a thread with positive lead and a single-pointed tool if it is rigged up as shown in Fig. 4. There are some jobs too large to be swung on a lathe, which may be handled this way to advantage, although to be sure it is a slow and clumsy way to do the work. Sometimes slow ways are the only ways, however, and this kink should be stored away in the small-shop man's mind for use on an occasion of that kind.

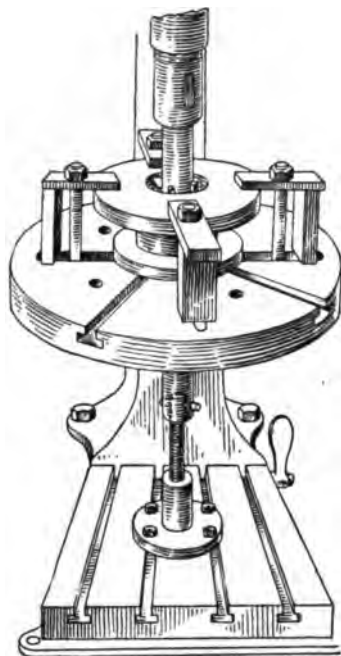

FIG. 4. THREADING WITH A LEADER ON THE DRILLING MACHINE

# Measuring Screw Threads in the Small Shop

BY JOHN H. VAN DEVENTER

**SYNOPSIS**—Measuring screw threads is a task that is undertaken with uncertainty in many shops. Ring and plug screw gages are commonly used, but do not always throw true light on the existing errors. This article tells how the small-shop man can measure threads with certainty, and also points out the sources of error to be looked for.

Casey was a good Irishman and a better mechanic, and was disgusted with the loss of time in his shop when it came to fitting screw threads. There were a good many studs to drive, and it was always a matter of sort and try to find those which would go in with the proper amount of pull. Some of them would fall in like a shot in a barrel and others would not even enter the hole. So Casey rigged up a block as shown in Fig. 1 in order that he

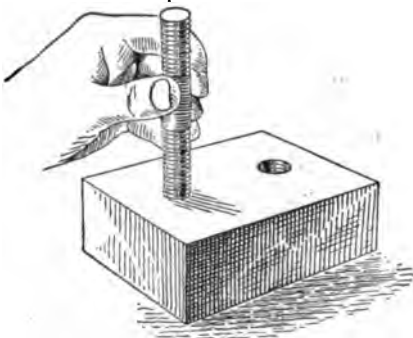

FIG. 1. THE OLD METHOD OF TRYING A SCREW IN A STANDARD HOLE STILL ANSWERS

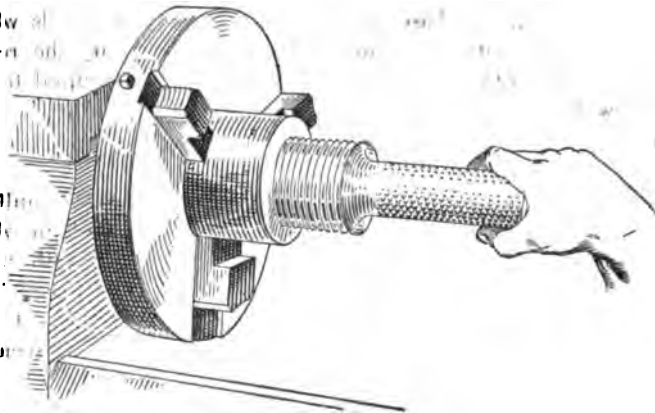

FIG. 2. CRUDE AS IT IS, THE SCREW PLUG SEEMS TO HAVE A MONOPOLY ON THREADED HOLES

might establish a standard. He succeeded in having his screws made to fit the block, but found that tapmakers seemed to have a difference of opinion regarding the size of a half inch. "Begorry," said Casey, "what an argument them fellows would have about the diameter of the earth if they've got such a difference of opinion on a half inch!"

This variance in the sizes of taps exists for the simple reason that the learned bodies mentioned in the article on page 25, when establishing the various screw thread standards, did not complete their job and also establish a

set of maximum and minimum limits on them. But the matter of importance and interest is not what these gentlemen did not do but what the small-shop man must do in order to be sure that threads will fit the holes for which they are intended.

There are twelve errors which may creep into the thread of a nut and there are twelve similar errors which may creep into the threads of a screw, so all together we have twenty-four reasons why one will not fit the other. These, for the sake of clearness, are arranged in the accompanying table.

Making the outside and root diameter of a screw too small will not affect the fit unless these errors are exces-

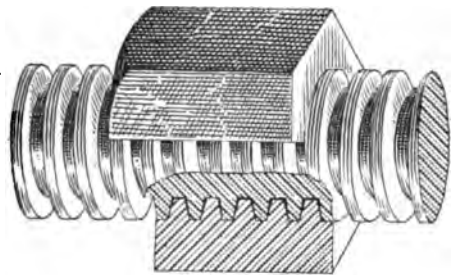
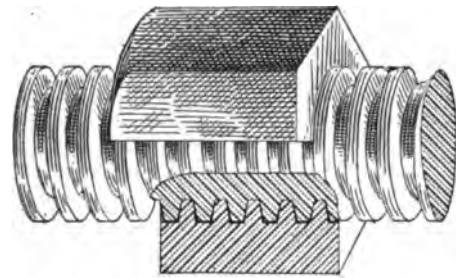

FIG. 3. THE RIGHT PITCH, BUT THE WRONG THREAD ANGLE FOR A PERFECT FIT

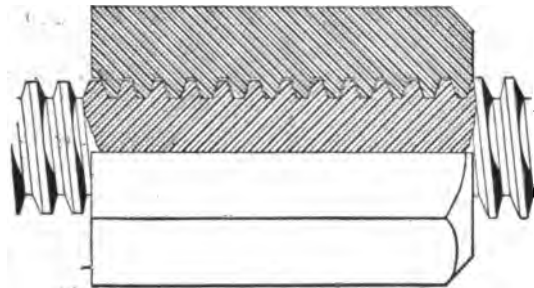

FIG. 4. THE SCREW TOO SMALL, BUT BINDING IN THE LEAD, SO THE CONTACT IS LIMITED

sive. Conversely, making the root and outside diameters of a nut too large often helps things instead of harming them. When the reverse is true, however, and the outside diameter of a screw is larger than the root diameter of the nut, there is trouble. This is usually what is encountered when one tries to screw a V-thread into a U. S. S. nut. The way to overcome this difficulty is to keep the V standard out of the shop. Sometimes the wrong thread angle on either screw or nut makes a defective fit which cannot be noticed because the pitch happens to be right. A case of this kind is shown in Fig. 3, where there is



## MEASURING SCREW THREADS IN THE SMALL SHOP

contact at the extreme corners of the threads and consequently no shape but a very poor fit. Another poor fit is shown in Fig. 4, in which the lead is stretched, apparently making a tight driving fit, but in reality having contact only on the surfaces of two or three threads.

Sometimes the pitch of both nut and screw may be right, the lead right, the angle right, the outside and root

ERRORS IN THREADED WORK	
Diameter (outside) .....	{ Too large
	{ Too small
Diameter (pitch) .....	{ Too large
	{ Too small
Diameter (root) .....	{ Too large
	{ Too small
Angle of thread .....	{ Too large
	{ Too small
Pitch of threads .....	{ Too large
	{ Too small
Lead — Not uniform	
Burrs and bruises	

diameters right, but everything all wrong nevertheless. This is because of the vital dimension, which cannot be seen and which is hard to measure, which is known as the

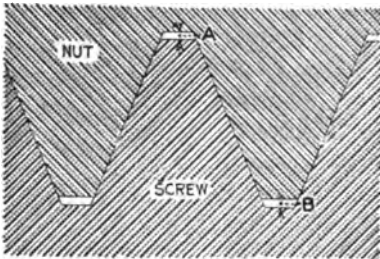

FIG. 5. SOME VARIATIONS IN DIAMETER ARE HARMLESS

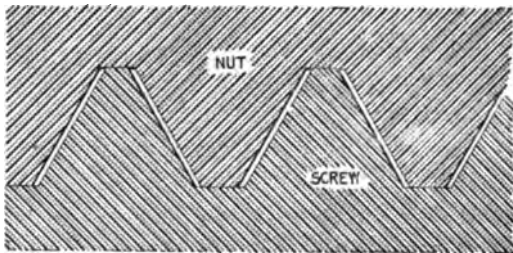

FIG. 6. THE PITCH RIGHT, THE LEAD RIGHT, THE ANGLE RIGHT — BUT ALL WRONG, NEVERTHELESS

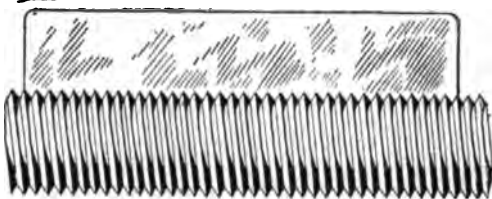

FIG. 7. TESTING THE LEAD WITH A SCREW PITCH GAGE

pitch diameter. A case of this kind is illustrated in Fig. 6 and would give a very shaky fit, while an error of the opposite kind in which the threads of the screw were too thick would make it impossible to enter the screw. Fortunately for most small-shop purposes, it is safe to assume that the angles of threads on purchased taps and dies are correct. Also for this class of work it is quite possible to test the lead of a screw by means of a gage such as shown in Fig. 7. These gages run from 2 to 4 in. in length, depending on the fineness of the pitch, and a little experience will make the shop man an expert in their use.

Limit thread gages for testing pitch diameters form a means of inspection that is absolutely decisive. These are used on precision work, but an individual gage is required for each diameter and pitch, which usually limits their application to shops in which a large quantity of pieces

having a limited number of thread sizes are handled. For average small-shop requirements, which will not call for measuring every screw used, three methods of measuring pitch diameter are available—the thread micrometer, the ball-point micrometers and the two- and three-wire systems. The latter can be used with an ordinary pair of mikes such as will be found in every small shop, and will

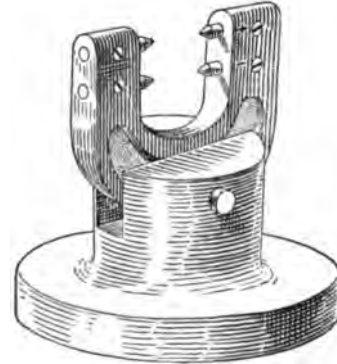

FIG. 8. LIMIT THREAD GAGES FOR TESTING PITCH DIAMETER

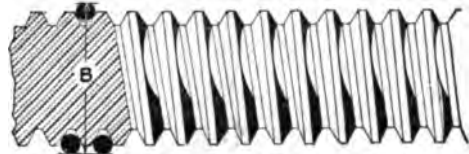
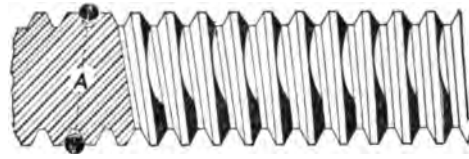

FIG. 9. MEASURING THREADS BY THE TWO- AND THREE-WIRE SYSTEMS

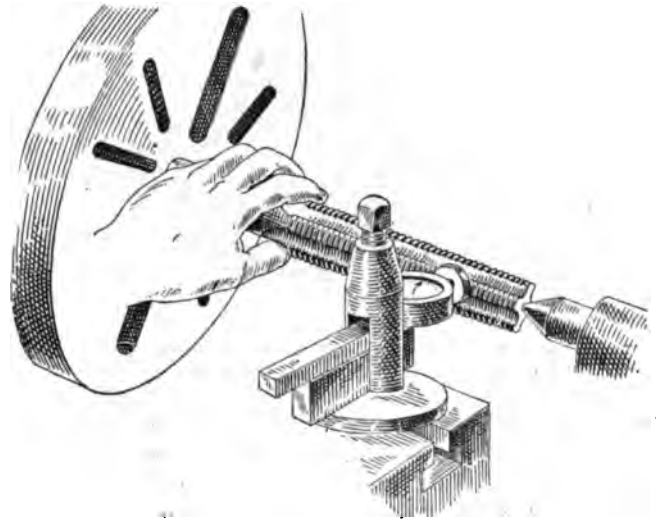

FIG. 10. TESTING A TAP FOR WARP BETWEEN LATHE CENTERS

give as accurate results as any method of measurement, although a little slower than the special micrometers made for this purpose. The method of using the two- and three-wire systems is indicated in Fig. 9. Wires are taken of proper size and measurement made across their outside diameters when laid in opposite thread spaces. The micrometer readings are compared with a table which gives the reading in terms of pitch diameter. Tables for this purpose for all of the standard threads can be found in the "American Machinist Handbook," pages 30 to 40.

## MAKING SMALL SHOPS PROFITABLE

While the thread angles on taps may be assumed to be correct, there are other things which it would be well to check up as soon as the taps come into the shop. A set of inspections for checking up taps are illustrated in Figs. 10 to 13. The first illustration shows a tap placed between lathe centers and being tested for warp and eccentricity due to distortion in hardening. Fig. 11 shows the

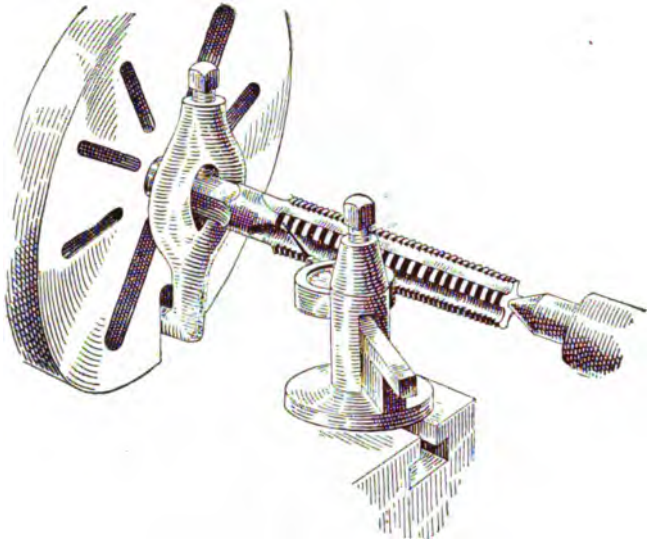

FIG. 11. COMPARING THE LEAD OF A TAP WITH THAT OF THE LATHE LEAD SCREW

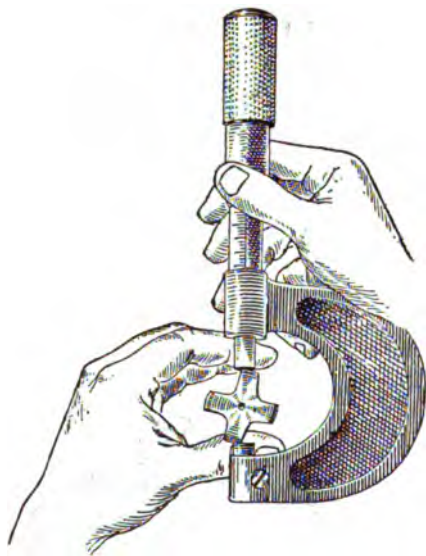

FIG. 12. MEASURING THE OUTSIDE DIAMETER OF THE TAP TO INSURE A FULL ROOT DIAMETER

means of comparing the lead of a tap with that of the lathe lead screw, which will indicate an error in the tap provided the lathe screw itself is accurate. An indicator is held in the tool post with its needle against one side of the tap face, the lead screw is engaged, the operator turns the belt by hand and eases off on the indicator needle from space to space, observing any fluctuation as the needle comes to rest on successive flutes. If the tap lead is right and the lathe screw lead is right, there should be no variation on the indicator.

The outside diameter of the tap must be large enough to insure a full root diameter of the tapped hole. This is measured with a pair of "mikes" as shown in Fig. 12. The final test is that of the pitch diameter, which is made as shown in Fig. 13, and which has been explained in the description of the three-wire system. If a tap passes these

four inspections satisfactorily, it is a *pretty good tool* as far as accuracy is concerned. To insure that the bolts, screws and studs that are purchased outside will fit properly into threads made with such a tap, it is advisable to inspect one or two of such studs, bolts or screws in every one hundred by means of running them into a block such as shown in Fig. 1. This, called selective inspection, will call attention to batches of screws which are running over or under size, in which case a further inspection of each screw in that batch may be made if desired before returning them to the maker. It is advisable for the small-shop man to protect himself in buying such screws by submitting a similar gage at the time that he gives the order.

Dies are best inspected by examining the work that comes from them. Do not, however, make the mistake as did one small-shop man of testing an adjustable die

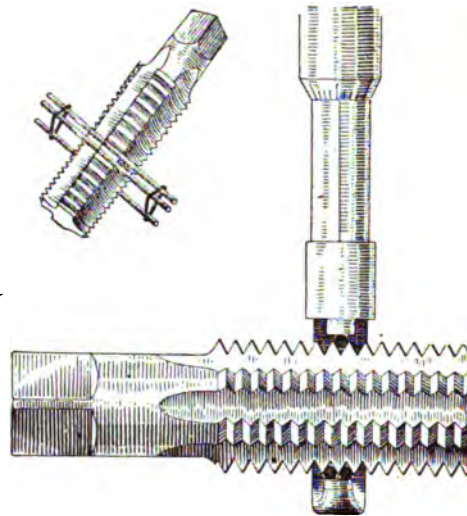

FIG. 13. MEASURING THE PITCH DIAMETER WITH "MIKES" AND WIRES

with stock that was larger than that intended for the chasers that were used. The chasers were supposed to cut twelve threads to the inch, but after the work came out of the die he could find but thirty-five threads in 3 in. One of them had disappeared mysteriously, and he is still hunting for it!

## Lifting the Shaper Chuck

By G. A. REMY

The vise, or chuck, on large shapers is heavy and, owing to its form, difficult to lift and place in position on the shaper table. Recently I saw three men put a large chuck in position without trouble, in the following manner:

Before the chuck was removed from the shaper, a piece of iron pipe was clamped between the vise jaws, the ends of the pipe protruding from the chuck far enough to furnish a grip. A man on each side lifted the chuck and, thanks to the pipe, easily held it in position over the table while a third man inserted the binding bolts and wiped away any chips that had fallen from the chuck to the table.

This is a simple method, but one not generally practiced. Besides avoiding the strain on the men in lifting, the machine is saved many hard knocks, which generally result when the men lifting the chuck have a poor grip. This idea is not original with me. I have seen it used by shaper hands.

# Hardening and Softening Steels in the Small Shop

By JOHN H. VAN DEVENTER

*SYNOPSIS—This article throws light on some right and some wrong ways to harden and anneal carbon and high-speed steels. The use of lead baths, cyanide of potassium and various quenching compositions is treated in detail.*

To take his diploma as an all-round small-shop machinist, a man must, in addition to many other requirements, be a fair blacksmith and a first-class tool hardener. The average small-shop owner cannot afford such a luxury as a tool specialist and may perhaps consider himself lucky that he cannot. The idea of specialization has been carried too far. If specialization were the real and ultimate object of man, we should be built differently. Some of us would have nothing but noses—we should do the smelling for the community; others would be exclusive specialists at seeing, and others at hearing. As it is, we are all constructed very much alike and evidently intended by nature to do many things well, although the teachings of the "superspecialists" would make us believe to the contrary.

Judging by the number of inquiries received by the *American Machinist* for information, the hardening and annealing of steels is a matter that is worth presenting to small-shop readers. Like a good many other subjects, different parts of it have been presented from time to time, dispersed over a number of volumes and a number of issues—each one bearing its share of information. In one or two articles on this subject I will try to gather together the most important things to be known and done in connection with hardening and annealing, especially from the viewpoint of practicability for use in the small shop.

## METHODS OF HEATING FOR HARDENING AND TEMPERING

The various ways of heating steels group themselves into three distinct divisions: First, in the open fire, in which the piece to be heated is exposed directly to the fuel. This scheme, the oldest, the best known and the commonest, is the one followed in ninety-nine shops out of a hundred. The blacksmith forge as a hardening and tempering appliance is as well known in the large shop as in the small one, and provided care is taken to use fuel free from sulphur and phosphorus and to build the fire deep enough so that the heated metal is not exposed to the direct blast, good results can be obtained. In using the open fire the degree of heat must be gaged by color, which is a disadvantage of this method of heating. While it may give best results some of the time and good results most of the time, it will not give best results all of the time, such as are assured when the degree of heat can be accurately measured and controlled.

The second classification of heating devices may be described as closed retorts or furnaces, in which the piece is protected not only from drafts, but also from attacks by the gases and chemical elements in the fuel. The size of such an outfit may vary from a muffle capable of being juggled about in one hand to a gigantic furnace. When

a furnace of this type is fired by oil or gas and is provided with a pyrometer, such as described on page 38, the heat may be closely regulated. I must not forget to mention in this class the electrically heated furnace, which is no doubt the most accurately controlled of any and which is largely used by makers of high-grade small tools as a means of heating their product.

## HEATING THE WORK IN A HOT BATH

The third class of heating appliances may be indexed under the name "Bath," although quite different from the Saturday night bath of the small-shop man. It may consist of a pot of melted lead, of melted salt, of potassium cyanide, of sand or of heavy oil. These are of course hot baths, as distinguished from the quenching or cooling baths, which will be mentioned later. The advantages of a bath of this kind are easily obtained in the small shop by placing upon the forge a crucible or an iron kettle containing the bath material. A better way to heat it and one that allows for regulation is by means of a gas or crude-oil burner.

The reason for uniformity of temperature in hardening steels may not be fully understood; and when not, it is difficult for one to realize the importance of maintaining a uniform temperature. In its action, when heated, steel somewhat resembles water. Just as heated water reaches a point where it boils and changes into steam, steel heated sufficiently reaches a point where its particles are changed in their nature and relation. On being cooled to a temperature a little lower than the first the particles will change back again.

These temperatures are called the "critical points" of the steel and vary with different percentages of carbon. The proper hardening temperature is from 30 to 50 deg. above the first critical point. The ideal temperature would be exactly at this point, but allowance must be thus made for cooling in the interval of time before quenching. A table showing these temperatures is given for various percentages of carbon, and it will be noticed that the higher the carbon of the steel the lower this critical temperature becomes.

Steel has a peculiar property of losing its power of attracting a magnet when the critical point is reached, and this fact is taken advantage of by some small-shop owners who do not have pyrometers. A magnetic compass is applied to the piece of heated steel; and when the needle ceases to be attracted by it, the shop man knows that the critical point has been reached.

## HARDENING AND ANNEALING TEMPERATURES FOR CARBON STEELS

Per cent. Carbon	" Points "	Deg. F.
0.10	10	1,616
0.20	20	1,562
0.30	30	1,535
0.40	40	1,508
0.50	50	1,492
0.60	60	1,481
0.70	70	1,476
0.80 to 1.5	80 to 150	1,472

The nearer to the critical point that the small-shop man is able to quench a piece of steel, the finer will be its grain. Its hardness and toughness will also reach a

## MAKING SMALL SHOPS PROFITABLE

maximum under these conditions. Over and under this point the grains become gradually coarser, and the hardness decreases.

One thing to remember in heating steels for hardening is to keep the temperature "going up" until the critical point is reached. In other words, it will not do to go above this point and let the temperature drop before quenching. Apparently it is necessary to keep the temperature moving in one direction, in order not to impede traffic among the busy molecules of the heated bar. While this is true, it is equally true that fast heating must be avoided. A piece of steel is often heated so quickly that the outside only is in its proper critical condition.

Every mechanic who has had anything to do with the hardening of tools knows how necessary it is to take a cut from the surface of the bar that is to be hardened. The reason is that in the process of making the steel its outer surface has become decarbonized. This change makes it low-carbon steel, which will of course not harden. It is necessary to remove from  $\frac{1}{16}$  to  $\frac{1}{4}$  in. of diameter on bars ranging from  $\frac{1}{2}$  to 4 in.

This same decarbonization occurs if the steel is placed in the forge in such a way that unburned oxygen from the blast can get at it. The carbon is oxidized, or burned out, converting the outside of the steel into low-carbon steel. The way to avoid this catastrophe is to use a deep fire. Lack of this precaution is the cause of much spoiled work, not only because of decarbonization of the outer surface of the metal, but because the cold blast striking the hot steel acts like boiling hot water poured into an ice-cold glass tumbler. The contraction sets up stresses that result in cracks when the piece is quenched. The next time you harden a milling cutter and have some of the teeth crack off, keep this suggestion in mind.

### PREVENTING DECARBONIZATION OF TAPS AND REAMERS

It is especially important to prevent decarbonization in such tools as taps and form cutters, which must keep their shape after hardening and which cannot be ground away on the profile. For this reason it is well to put taps, reamers and the like into pieces of pipe in heating them. The pipe need be closed on one end only, as the air will not circulate readily unless there is an opening at both ends for a "draft," so to speak.

Even if used in connection with a blacksmiths' forge the lead bath has an advantage for heating tools of complicated shapes, since it is easier to heat them uniformly and they are submerged and away from the air. You must remember, however, that unless the metal is stirred, the temperature of such a bath is not uniform. And always remember to use powdered charcoal as a covering for the top of the lead pot. Some may ask why it is necessary to repeat such a simple precaution, but a prominent firm making shrapnel incurred much expense for wasted lead until someone suggested the use of charcoal. A lead bath may be used at temperatures between 620 and 1,150 deg. F. Beyond this there will be much waste by evaporation.

To secure proper hardness, the cooling or quenching of steel is as important as its heating. Quenching baths vary in nature, there being a large number of ways to cool a piece of steel in contrast to the comparatively few ways of heating it.

Plain water, brine and oil are the three most common quenching materials. Of these three the brine will give

the most hardness, and plain water and oil come next. The colder that any of these baths is when the piece is put into it the harder will be the steel; but this does not mean that it is a good plan to dip the heated steel into a tank of ice water, for the shock would be so great that the bar would probably fly to pieces. In fact, the quenching bath must be sometimes heated a bit to take off the edge of the shock.

Brine solutions will work uniformly, or give the same degree of hardness, until they reach a temperature of 150 deg. F., above which their grip relaxes and the metals quenched in them become softer. Plain water holds its grip up to a temperature of approximately 100 deg. F.; but oil baths, which are used to secure a slower rate of cooling, may be used up to 500 deg. or more. A compromise is sometimes effected by using a bath consisting of an inch or two of oil floating on the surface of water. As the hot steel passes through the oil, the shock is not as severe as if it were to be thrust directly into the water; and in addition, oil adheres to the tool and keeps the water from direct contact with the metal.

The old idea that mercury will harden steel more than any other quenching material has been exploded. A bath consisting of melted cyanide of potassium is useful for heating fine engraved dies and other articles that are required to come out free from scale. One must be careful to provide a hood or exhaust system to get rid of the deadly fumes coming from the cyanide pot.

### EASING OFF THE INTERNAL STRESSES

Work quenched from a high temperature and not afterward tempered will, if complex in shape, contain many internal stresses, which may later cause it to break. They may be eased off by slight heating without materially lessening the hardness of the piece. One way to do this is to hold the piece over a fire and test it as Mrs. Small-Shop Man tests her hot flatiron—with a moistened finger. Another way is to dip the piece in boiling water after it has first been quenched in a cold bath. Such steps are not necessary with articles which are afterward tempered and in which the strains are thus reduced.

In annealing steels the operation is similar to hardening, as far as heating is concerned. The critical temperatures given in the table are the proper ones for annealing as well as hardening. From this point on there is a difference, for annealing consists in cooling as slowly as possible. The slower the cooling the softer will be the steel.

Annealing may be done in the open air, in furnaces, in hot ashes or lime, in powdered charcoal, in burnt bone, in charred leather and in water. There is surely some range of choice for the small-shop man when it comes to doing this work. Open-air annealing will do as a crude measure in cases where it is desired to take the internal stresses out of a piece. Care must be taken in using this method that the piece is not exposed to drafts or placed on some cold substance that will chill it. Furnace annealing is much better and consists in heating the piece in a furnace to the critical temperature and then allowing the work and the furnace to cool together.

When lime or ashes are used as materials to keep air away from the steel and retain the heat, they should be first heated to make sure that they are dry. Powdered charcoal is used for high-grade annealing, the piece being packed in this substance in an iron box and both the work and the box raised to the critical temperature and

then allowed to cool slowly. Machinery steel may be annealed in spent ground-bone that has been used in casehardening; but tool steel must never be annealed in this way, as it will be injured by the phosphorus contained in the bone. Charred leather is the best annealing material for high-carbon steel, because it prevents decarbonizing taking place.

Water annealing consists in heating the piece, allowing it to cool in air until it loses its red heat and becomes black and then immediately quenching it in water. This plan works well for very low-carbon steel; but for high-carbon steel what is known as the "double annealing treatment" must be given, provided results are wanted quickly, as is usually the case with water or oil-bath annealing. The process consists of quenching the steel in water or oil, as in hardening, and then reheating it to just below the critical point and again quenching it in oil. This process retains in the steel a fine-grain structure combined with softness. Large pieces of steel should be rough-turned before annealing. It will not be necessary to say anything about color tempering, this being a subject familiar to all. In drawing temper, however, the color is not the only gage that can be used. One of the best is a thermometer in a bath of heavy oil having a flash point between 500 and 600 deg., which will take care of all the tempers up to that corresponding to dark blue. The steel is first preheated slowly in a fire or furnace, as it might crack if plunged immediately into the hot oil.

In hardening high-speed steel the main requirement is to get the cutting edge hot enough. The air blast for cooling is going out of fashion and an oil bath is taking its place, which will be good news to the small shop that has no air compressor. Lathe and planer tools are usually left in their quenched condition for use, not being tempered or drawn. More complicated and expensive high-speed steel cutters are somewhat insured against breakage by drawing the temper slightly. Milling cutters are drawn to 400 deg. F., drills and reamers to 450 deg. and taps and dies are let down a little farther, not, however, reaching 500 deg.

### Boring Pump Chambers in the Drilling Machine

BY A. N. PATTERSON

In the illustration, Fig. 1, is shown a pump-chamber pocket that was bored in a drill press. The top flange was faced, drilled and tapped before the boring was done. This was permissible, as the pockets had no relation one to the other, and the distances between centers of the chambers did not have to be absolutely accurate.

In Fig. 2 is shown the arrangement of tools for all operations. A is a plate to hold the guide bushing B; this plate was secured to the top flange by capscrews in the tapped holes. The method of operation is as follows: The boring bar in the spindle of the drill press is raised

clear of the work, the guide bushing B is slipped over the bar and the cutter inserted and secured. The bar is then lowered to the work, the bushing being pushed down in the plate, and the boring commenced.

A roughing and finishing cutter was used for each diameter to be bored. The dimensions of the bar and bushing were such that the bushing would enter the plate before the cutting commenced, so that the bar was always guided when boring.

The tool used for chamfering the bottom of the hole is

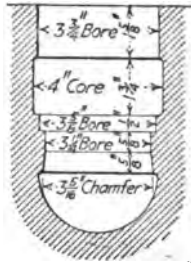

FIG. 1. THE HOLE TO BE MADE

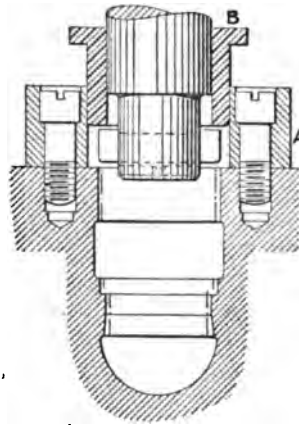

FIG. 2. ARRANGEMENT OF TOOLS

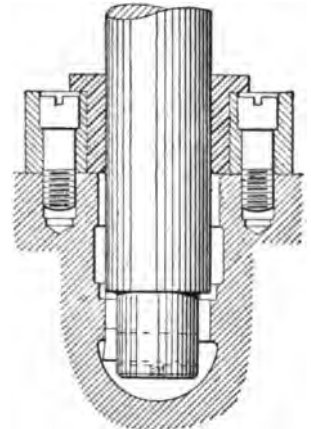

FIG. 3. THE CHAMFERING TOOL

shown in Fig. 3. In doing this operation the bushing was raised clear of the plate and the boring bar and tool inserted eccentrically in the hole, to permit it to enter. The bushing was then forced into the plate, centering the bar, and by feeding upward the hole was chamfered.

### A Handy Driver for Removing Shell Sockets

BY JOHN DUNN

The accompanying sketch shows a very handy driver for removing the brass socket from an 18-lb. shrapnel shell in order to correct the weight or put on a new socket.

The shell is first heated to break the solder joint between the brass socket and the tube. The plug is then screwed

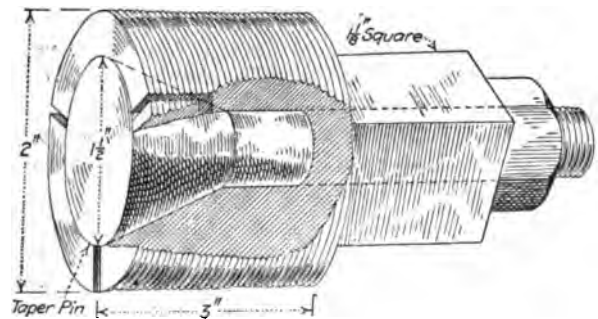

SHELL-SOCKET REMOVER

in. Tightening the nut on top expands the plug; then by the use of a large wrench the socket may be backed out. This driver will not harm the socket, which may be put back in the ordinary way, and it makes an otherwise nasty job very easy.

# Carbonizing Small-Shop Steels

BY JOHN H. VAN DEVENTER

*SYNOPSIS—Carbonizing is the first step in casehardening. Unless this part of the work is done with a knowledge of the principles involved, the final result will be uncertain. This article gives an explanation of the action of carbonizing processes as applied to both low- and high-carbon steels.*

Out in the woods of North Carolina, ten miles from the nearest populated point, a gang of men were converting pine trees into rough lumber. For this purpose they used axes and a portable sawmill outfit run by a side-crank engine such as is commonly found in these migrating lumber camps. One day the boiler, which was rather inclined to bad attacks or spasms, delivered an unusually large gob of water through its discharge pipe to the long-suffering engine cylinder just at the time that the saw was biting its way through a pugnacious pine knot. The combination of circumstances was too much for the crosshead pin of the engine.

"I don't see what made the darn thing break," said the lanky North Carolinian who acted not only as boss of the outfit, but also as master mechanic. Indeed the fracture, to one who was not experienced in such matters, would appear to be a good one. Still, it was evident that something must have been wrong with the pin, for by all expectations the cylinder head should have gone before this part of the apparatus gave away.

To get at the real reason for this mishap, which meant the loss of many dollars and a shutdown of many days to this lumber camp, let us go back to the factory in which this crosshead pin was made and see how the work was done. If the lanky lumber-camp boss could go along with us and also see what caused the accident, I am sure that he would be more particular in the future in buying an engine and possibly willing to pay enough to avoid the junk that is frequently offered.

In the shop that built this engine the aim was not so much to give service as it was, to put it crudely, to find suckers. The idea was to produce an engine at the lowest possible cost, sell it at a price that would be an inducement much greater than quality and not worry too much about what happened to it after it was in use. One of the safeguards of this policy was the knowledge of many ways by which a skillful correspondent can make defects of construction appear as errors in operation.

To make the descriptive matter as imposing as possible, such items as charcoal-iron castings, hammered babbitt bearings and casehardened pins were described at length, although as a matter of actual fact the nearest that any charcoal got to the iron was in the fire used in drying the skin of the mold, and the only hammering that the bearings received was that due to the pounding of the rod after the engine was in service. As for the case-hardened pins, the blacksmith took them under his wing after they were fully machined, heated them up in his forge, sprinkled a little cyanide of potassium over their surfaces, turned them around in the fire once or twice, to get the same effect as is obtained by basting chickens, and then plunged them into a cold brine solution. This

procedure did make the outer skins of these pins very hard, but it left the inner core extremely coarse-grained and weak. The pin could not be touched with a file and might appear to be a very long-wearing product, but was brittle and weak. If it had really been wise on the subject of carbonizing and casehardening, this firm could have avoided this feature and also reduced the cost of carbonizing the crosshead pin—getting a high-grade result for less money.

Casehardening divides itself into two parts—carbonizing and quenching. A great many people think that the quenching must be done at the same heat as that at which the piece is carbonized. This idea is entirely wrong, and these two processes can be regarded as separate operations; in fact, in this article I will stick to the

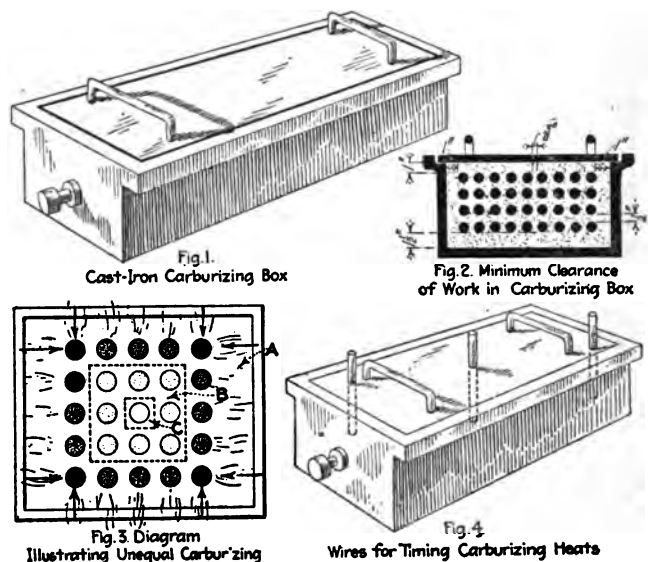

FIGS. 1 TO 4. CARBONIZING BOXES AND DETAILS ILLUSTRATING THEIR USE

carbonizing part of it as closely as possible and save the quenching for another time.

There are four different reasons for casehardening, and they must be considered in connection with the way of doing it. The first is to secure a hard surface—maximum hardness to resist wear without shock. Again, a piece may be casehardened for the purpose of securing stiffness, thus reducing the likelihood of the stretching of light sections while at the same time allowing the use of cheap machinery-steel stock. A third purpose is to secure colors on certain classes of work. The fourth, which is possibly the least understood in most shops, is that of securing a hard cutting edge, not only on low-carbon steels, but also on tool steels.

These different purposes are secured by the proper selection of the carbonizing material in which the articles are packed and of the bath in which they are quenched.

The general practice of carbonizing is as follows: The articles are placed in cast-iron boxes surrounded by materials that will give up carbon when heated. These boxes and their contents are next heated through, beyond the critical point of the steel involved (see page 31) and are allowed to soak at this temperature for a length

## CARBONIZING SMALL-SHOP STEELS

of time depending on the depth of case wished. A convenient box for this purpose is shown in Fig. 1.

There are certain precautions to be taken in packing a box of this kind. In the tug-of-war to absorb whatever free carbon is released by the heated carbonizing material, cast iron has a much stronger pull than has steel. As a result, if the pieces are placed too near the cast-iron walls of the containing box, these walls will get the benefit of the carbon to the detriment of the pieces. Fig. 2 shows a cross-section through a casehardening box and gives the minimum clearances for the articles with relation to each other and to the walls and bottom of the box.

The casehardening box must not be too large, especially for light work that is run on a short heat. The reason for this is shown in the diagram in Fig. 3. When a box of this kind is put into a furnace, it heats from the outside toward the center, taking from one-half hour to an hour and a half to heat through uniformly, depending upon the liveliness of the fire. If the contents of such a box are dumped after a short heat, the pieces on the outside rows will have been at the carbonizing heat much larger than those nearer the center of the box, the result being a much greater gain in carbon in these outer pieces, as illustrated by the sectional shading in Fig. 3.

The temperature to be used for carbonizing depends on the amount of carbon already in the steel to be treated. This temperature must be above the critical point of the steel; and if you know its carbon contents, you can obtain this point from the table on page 31. Low-carbon machinery steel containing from 15 to 20 points carbon is commonly used for this purpose, and such steels must be heated to between 1,650 and 1,750 deg. F. The more carbon that there is in the steel to start with the slower it will be in taking on additional carbon and the lower is the temperature required. In ordinary casehardening, the outer surface of steel has its carbon increased from 15 or 20 points to 80 or 85 points. Tool steels may be carbonized as high as 250 points, but this amount is a maximum and is seldom, if ever, required.

The materials used for carbonizing are many. Among the most common are wood and bone charcoal, ground or crushed bone, charred leather, horns and hoofs. There

Each of these different packing materials has a different effect upon the work in which it is heated. Charcoal by itself will give a rather light case. Mixed with raw bone it will carbonize more rapidly, and still more so if mixed with burnt bone. Raw bone and burnt bone, as may be inferred, are both quicker carbonizers than charcoal, but raw bone must never be used where the breakage of

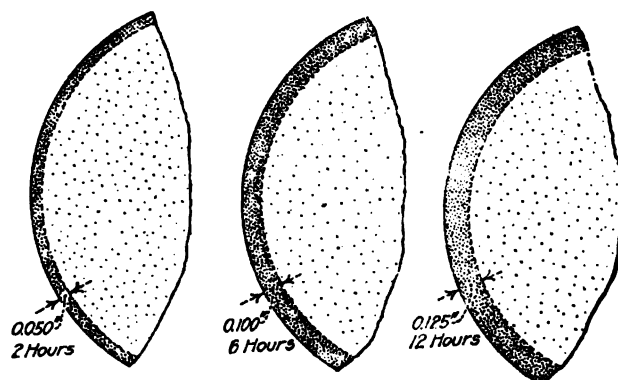
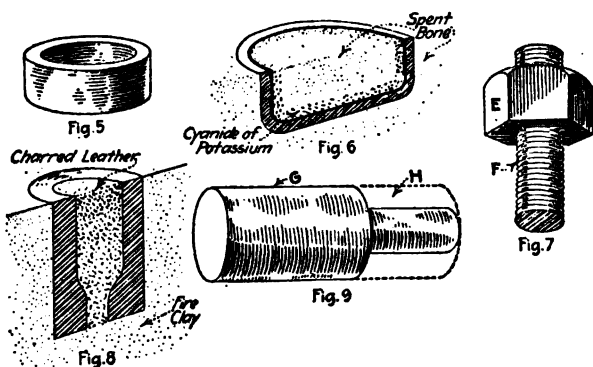

FIG. 10. ORDINARY CASE PENETRATION IN LOW-CARBON STEEL FOR VARIOUS HEATS

hardened edges is to be avoided, as it contains phosphorus and tends to make the piece brittle. Charred leather mixed with charcoal is a still faster material, and horns and hoofs exceed even this in speed; but these two compounds are restricted by their cost to use with high-grade articles, usually of tool or high-carbon steel, that are to be hardened locally—that is, “pack-hardened.” Cyanide of potassium and prussiate of potash are also included in the list of carbonizing materials; but outside of carbonizing by dipping into melted baths of these materials, which I will describe later, their use is largely confined to local hardening of small surfaces, such as holes in dies and the like.

One of the advantages of hardening by carbonizing is the fact that you can arrange to leave part of the work soft and thus retain the toughness and strength of the original material. Figs. 5 and 9 show ways of doing this. The inside of the cup in Fig. 5 is locally hardened, as illustrated in Fig. 6, “spent” or used bone being packed around the surfaces that are to be left soft, while cyanide of potassium is put around those which are desired hard. The threads of the nut in Fig. 7 are kept soft by carbonizing the nut while upon a stud. The profile gage, Fig. 8, is made of high-carbon steel and is hardened on the inside by packing with charred leather, but kept soft on the outside by surrounding it with fireclay. The rivet stud shown in Fig. 9 is carbonized while of its full diameter and then turned down to the size of the rivet end, thus cutting away the carbonized surface. Pieces of this kind are of course not quenched and hardened in the carbonizing heat, but are left in the box to cool, just as in box annealing, being reheated and quenched as a second operation. In fact, this is a good scheme to use for the majority of carbonizing work of small and moderate size. Sometimes it is wished to harden a thin piece of sheet steel halfway through, retaining the soft portion as a backing for strength. Material is on the market with which one side of the steel can be treated; or copper-plating one side of it will answer the same purpose and prevent that side becoming carbonized.



FIGS. 5 TO 9. LOCAL CARBONIZING BY THE USE OF VARIOUS METHODS

are also combined preparations, one of the best of which is a mixture of barium carbonite, 40 per cent., and charcoal, 60 per cent. This mixture gives a rate of penetration which is from 10 to 20 per cent. faster than that of charcoal, bone or leather. Fig. 10 shows the penetration of this mixture on ordinary low-carbon machinery-steel stock over a range of 2 to 12 hr.

# Casehardening Small-Shop Steels

BY JOHN H. VAN DEVENTER

*SYNOPSIS—This article deals with the subject of quenching case-carbonized articles and with the heat treatment of such pieces to secure maximum toughness. Pack-hardening is discussed and also the casehardening of alloy steels and cast iron. A combination quenching tank for hardening and coloring is illustrated.*

All blacksmiths are by nature and training more or less experimenters, and very few have not some "secret" formula for accomplishing wonderful results in hardening. Cast-iron hardening has received a good part of their attention in this respect with varying degrees of success. While it has been an easy matter to make cast iron extremely hard on the surface—in fact, as hard as the hardest tool steel—no one has as yet found a way to add the element of strength to this hardness without which its use is limited to gages, templates and other things that do not require much strength.

Some amusing results often accompany such experiments. One blacksmith of my acquaintance, who had obtained very fair results with cast-iron hardening, was always searching for some chemical or compound to add to the quenching bath to make this "grip" the metal more forcible. This "grip" is a noticeable thing in hardening cast iron; not only can you feel it on the end of the tongs, but when certain solutions are used, it becomes so forcible as to make itself heard—making one think that a miniature torpedo was exploding beneath the surface of the water. I was passing through his blacksmith shop one day when a new mixture was being tried out. As soon as the blacksmith plunged the red-hot casting into the barrel containing this mixture, there was a violent explosion in which blacksmith, barrel, quenching mixture and casting were indiscriminately mixed. The experimenter picked himself up, felt of the various parts of his anatomy to see what was missing and, finding himself intact, exclaimed regretfully: "Say, what a fine mixture that would be if you could only get a barrel strong enough to hold it!" I do not know what caused this explosion, but having seen it, can be sure that it happened and also that it put an end to the experimenting of this particular blacksmith, who afterward stuck to the tried and tested formulas. Probably the heat of the casting was all that was needed to set up some powerful chemical reaction between the elements in the bath.

An old formula that has done good service in the matter of surface-hardening cast iron is as follows: To 20 gal. of water add 1 pint of oil of vitriol, 2 pecks of salt, 4 lb. of alum,  $\frac{1}{2}$  lb. yellow prussiate of potash,  $\frac{1}{2}$  lb. cyanide of potash and 1 lb. saltpeter. This bath can be kept in a covered wooden barrel. The casting is heated cherry-red and then plunged into this bath, which hardens its surface. Sometimes it is necessary to repeat this performance two or three times to get the surface sufficiently hard.

The quenching tank is an important feature of apparatus in casehardening—possibly more so than in ordinary tempering. One reason for this is because of the large quantities of pieces usually dumped into the tank at a time. One cannot take time to separate the articles themselves from the casehardening mixture, and the whole content of the box is dropped into the bath in short order, as exposure to air of the heated work is fatal to results. Unless it is split up, it is likely to go to the bottom as a solid mass, in which case very few of the pieces are properly hardened. A combination cooling tank is shown in Fig. 1. Water inlet and outlet pipes are shown and also a drain plug that enables the

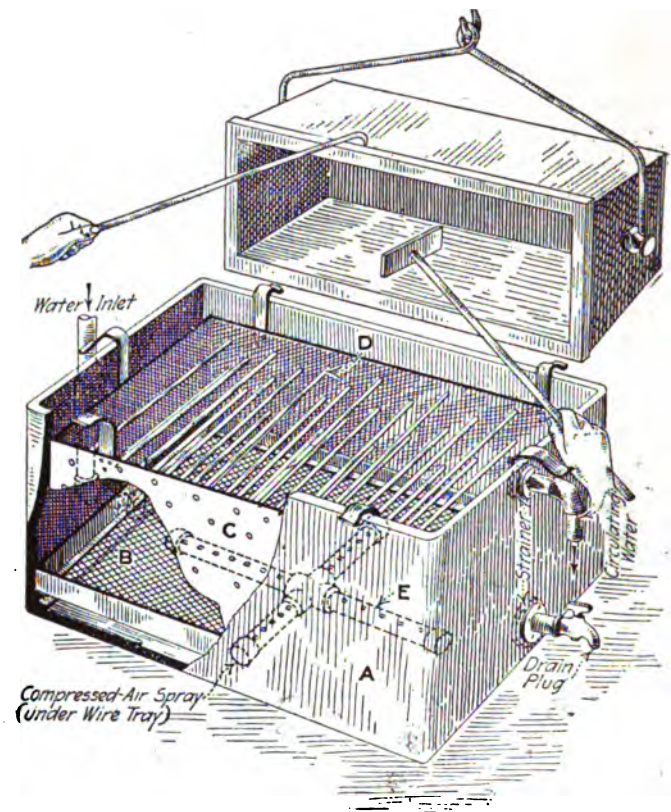

FIG. 1. COMBINATION COOLING TANK FOR CASEHARDENING

tank to be emptied when it is desired to clean out the spent carbonizing material from the bottom. A wire-bottomed tray, framed with angle iron, is arranged to slide into this tank from the top and rests upon angle irons screwed to the tank sides. Its function is to catch the pieces and prevent them from settling to the tank bottom, and it also makes it easy to remove a batch of work. A bottomless box of sheet steel is shown at C. This fits into the wire-bottomed tray and has a number of rods or wires running across it, their purpose being to break up the mass of material as it comes from the carbonizing box.

Below the wire-bottomed tray is a perforated cross-pipe that is connected with a compressed-air line. This is used when casehardening for colors. The shop that



## CASEHARDENING SMALL-SHOP STEELS

has no air compressor may rig up a satisfactory equivalent in the shape of a low-pressure hand-operated air pump and a receiver tank, for it is not necessary to use high-pressure air for this purpose. When colors are desired on casehardened work, the treatment in quenching is exactly the same as that previously described except that air is pumped through this pipe and keeps the water agitated. The addition of a slight amount of powdered cyanide of potassium to the packing material used for carbonizing will produce stronger colors, and where this is the sole object, it is best to maintain the box at a dull-red heat.

The old way of casehardening was in nine shops out of ten to dump the contents of the box at the end of the carbonizing heat; in fact, this plan still exists in many shops that should know better. Later study in the structure of steel thus treated has caused a change in this procedure, the use of automobiles and alloy steels probably hastening this result. The diagrams reproduced in Fig. 2 show why the heat treatment of casehardened work is necessary. Starting at A with a close-grained and tough stock, such as ordinary machinery steel containing from 15 to 20 points of carbon, if such work is quenched on a carbonizing heat, the result will be as shown at B. Here we have a core that is coarse-grained and brittle and an outer case that is fine-grained and hard, but is likely to flake off, owing to the great difference in structure between it and the core. Reheating

purpose of letting down the hardness of the case and giving it additional toughness by heating to a temperature between 300 and 500 deg. Usually this is done in an oil bath. After this the piece is allowed to cool.

It is possible to harden the surface of tool steel extremely hard and yet leave its inner core soft and tough for strength, by a process similar to casehardening and known as "pack-hardening." It consists in using tool steel of carbon contents ranging from 60 to 80 points, packing this in a box with charred leather mixed with wood charcoal and heating at a low-red heat for 2 or 3 hr., thus raising the carbon content of the exterior of the piece. The article when quenched in an oil bath will have an extremely hard exterior and tough core. It is a good scheme for tools that must be hard and yet strong enough to stand abuse. Raw bone is never used as a packing for this class of work, as it makes the cutting edges brittle.

### CASEHARDENING TREATMENTS FOR VARIOUS STEELS

Plain water, salt water and linseed oil are the three most common quenching materials for casehardening. Water is used for ordinary work, salt water for work which must be extremely hard on the surface, and oil for work in which toughness is the main consideration. The higher the carbon of the case, the less sudden need the quenching action take hold of the piece; in fact, experience in casehardening work gives a great many combinations of quenching baths of these three materials, depending on their temperatures. Thin work, highly carbonized, which would fly to pieces under the slightest blow if quenched in water or brine, is made strong and tough by properly quenching in slightly heated oil. It is impossible to give any rules for the temperature of this work, so much depending on the size and design of the piece; but it is not a difficult matter to try three or four pieces by different methods and determine what is needed for best results.

The alloy steels are all susceptible of casehardening treatment; in fact, this is one of the most important heat treatments for such steels in the automobile industry. Nickel steel carbonizes more slowly than common steel, the nickel seeming to have the effect of slowing down the rate of penetration. There is no cloud without its silver lining, however, and to offset this retardation, a single treatment is often sufficient for nickel steel; for the core is not coarsened as much as low-carbon machinery steel and thus ordinary work may be quenched on the carbonizing heat. Steel containing from 3 to 3½ per cent. of nickel is carbonized between 1,300 and 1,400 deg. F. Nickel steel containing less than 25 points of carbon, with this same percentage of nickel, may be casehardened by cooling in air instead of quenching.

Chrome-nickel steel may be casehardened similarly to the method just described for nickel steel, but double treatment gives better results and is used for high-grade work. The carbonizing temperature is the same, between 1,300 and 1,400 deg. F., the second treatment consisting of reheating to 1,400 deg. and then quenching in boiling salt water, which gives a hard surface and at the same time prevents distortion of the piece. The core of chrome-nickel casehardened steel, like that of nickel steel, is not coarsened excessively by the first heat-treatment, and therefore a single heating and quenching will suffice for ordinary work.

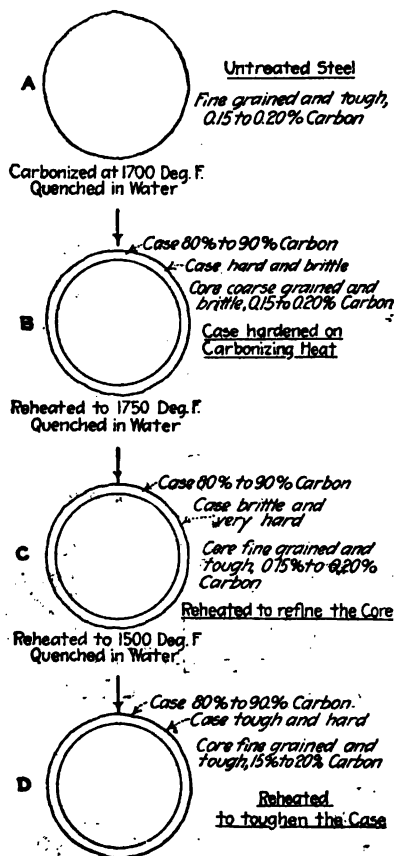

FIG. 2. WHY HEAT TREATMENT OF CASEHARDENED WORK IS NECESSARY

this work beyond the critical temperature of the core refines this core, closes the grain and makes it tough, but leaves the case very brittle; in fact, more so than it was before. This is remedied by reheating the piece to a temperature slightly above the critical temperature of the case, this temperature corresponding ordinarily to that of steel having a carbon content of 85 points. When this is again quenched, the temperature, which has not been high enough to disturb the refined core, will have closed the grain of the case and toughened it. Thus, instead of but one heat and one quenching for this class of work, we have three of each, although it is quite possible and often profitable to omit the quenching after carbonizing and allow the piece or pieces and the case-carbonizing box to cool together, as in annealing. Sometimes another heat-treatment is added to the foregoing, for the

# Taking Small-Shop Temperatures

BY JOHN H. VAN DEVENTER

*SYNOPSIS—The small-shop man is not interested in abstract theories. But if an appliance, tool or instrument will help him make more money or produce a better product, he wants it. This article deals with pyrometers from the small-shop users' viewpoint.*

Why does an Indian decorate himself with feathers and war paint, a doctor write prescriptions in hog Latin, and a scientist cover up a new grain of knowledge with a

name that has been dead and buried for ten thousand years? Not because any one of these individuals has a grudge against the small-shop owner, but because each is instinctively following one of the three inherited principles of the preservation of prestige. The Indian is putting up a physical bluff—decorating his body so that he will appear imposing. The scientist is putting up a mental bluff—decorating his discovery with a name that will be hard for common people to pronounce and understand. The doctor is not bluffing at all—he is just keeping business in the family, and the worst part of it is that all three of these fellows get away with it!

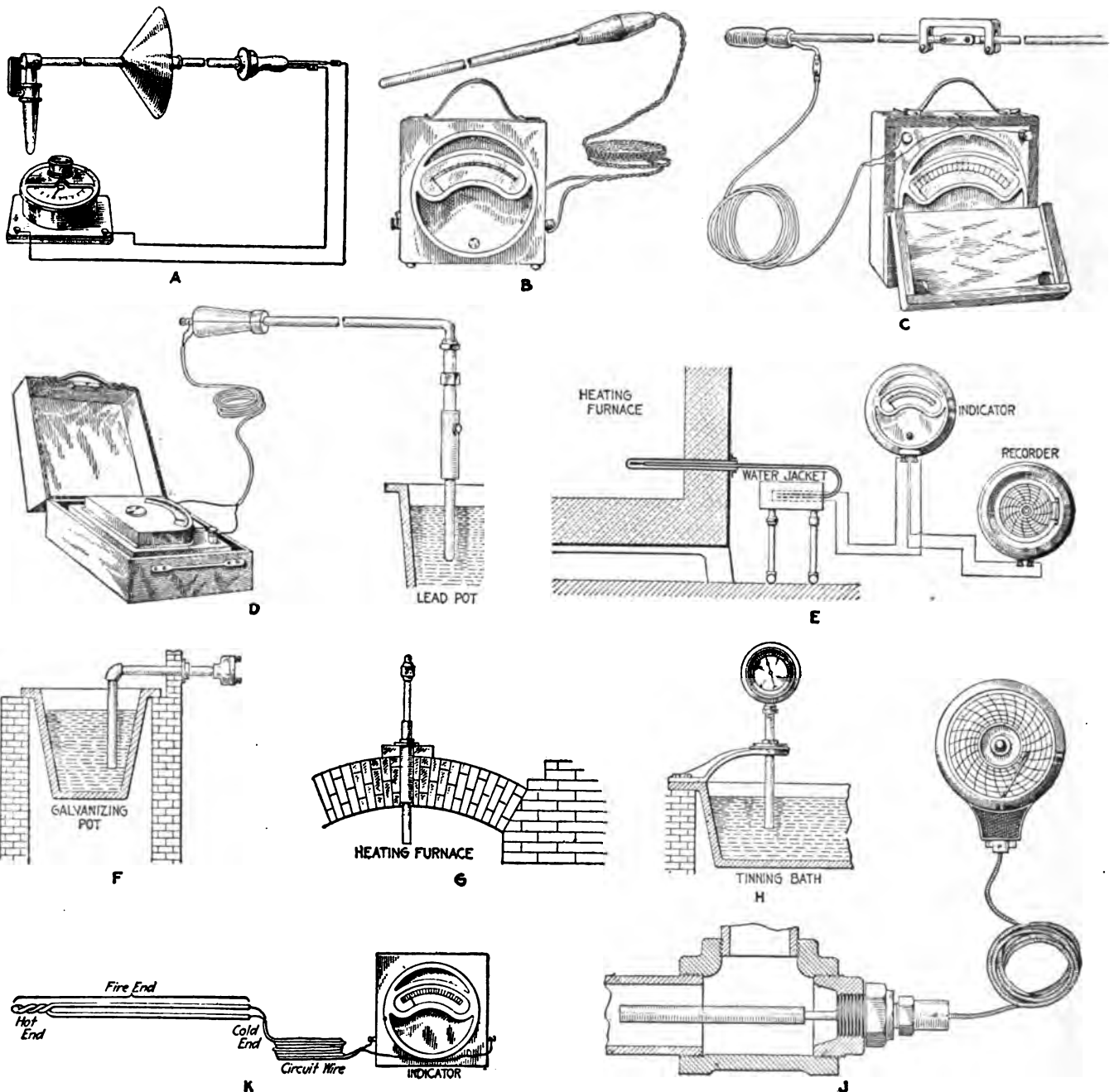

VARIOUS TYPES OF PYROMETERS SUITABLE FOR USE IN THE SMALL SHOP

A—Le Chatelier portable thermocouple pyrometer. B—Hoskins portable pyrometer. C—Bristol portable thermocouple pyrometer. D—Englehard portable bent mounting for lead pots, etc. E—Hoskins base-metal thermocouple with indicator and recorder and water-cooled cold end. F—Brown base-metal thermocouple with bent mounting. G—Le Chatelier rare-metal fire end mounted in arch of heating furnace. H—Brown expansion pyrometer mounted in tinning bath. J—Bristol gas-expansion recording thermometer mounted for temperatures of fluid under pressure.

## TAKING SMALL-SHOP TEMPERATURES

I believe that a man who invents a new machine or appliance and then goes back to the Dark Ages to find a name for it is unconsciously handicapping its sale and use. The name conveys the impression that the thing itself is highly scientific and thus erects a barrier of exclusiveness. Of course if it is something that people need, the demand for it will in time overcome the handicap of the name, which will become familiar; but nevertheless the handicap exists at first and is an unnecessary tone. Take, for example, tachymeters, scleroscopes and pyrometers—one of a bashful and retiring disposition might hesitate to make the acquaintance of such high brows, whereas he would be glad to shake hands with a “speed gage,” “hardness tester” and “heat gage.”

This may be one reason why the measurement of temperatures in small shops is not as thoroughly understood as it should be. It takes time for instruments which originate in the laboratory to filter down to the level of small-shop practicability. But I venture to predict that 20 years from now the pyrometer will be as familiar and well understood a small-shop tool as is the micrometer at the present day.

Twenty years ago a micrometer was seldom found in a small shop. Nowadays you seldom find a small shop without one. Progress has made it necessary to work to close limits of size, and the use of proper size-measuring instruments followed this as a natural result. With later progress has come the refinement of materials which calls for some means to measure temperature as the micrometer measures diameter.

### OLD MAN JONES, OF LANCASTER—AN OPTIMIST

Old Man Jones, of Lancaster, took a contract for some machines, among the parts of which were a number of nickel-steel heat-treated gears. He never had handled any alloy-steel work in the past, but had a blacksmith who was a crackerjack at hardening springs and cutting tools. Jones, being a progressive chap, determined to meet and get acquainted with the alloy-steel proposition, as he could see considerable business for one able to handle it. After careful machining, the gears were handed over to the blacksmith for heat-treatment. This gentleman was not as optimistic on the subject as Old Man Jones but said that he would do the best he could. The heat-treatment specified was to heat these gears to 1,550 deg., quench, reheat to 1,350, quench, and reheat to 800 deg., after which they were to be slowly cooled.

The first act of the worthy smith was to look up a color chart and translate the heat-treatment temperatures into colors instead of degrees. He found that 1,550 deg. F. represented a medium cherry red, 1,350 a dark red, and 800 deg. the lowest visible red. It was really as easy as matching shades of silk in a dry-goods store without the samples!

The furnace was a small one, and as a result the job had to be divided into several batches which were separately heated. When they were finished, the gears all looked much alike except that some had a little more scale than others. They rang the same when tapped with a hammer and seemed to give the same amount of pull upon a smooth file.

Old Man Jones and his blacksmith tried almost everything they could think of to test those gears, except biting a piece out of each of them. They were sure that they had a good job, but the customer's inspector did not

seem willing to take their view of the matter. He put the gears under a strange-looking instrument that was a cross between a thermometer and an atomizer and declared that twenty-three out of thirty-five would not pass the required hardness test.

“Why don't you fellows get a pyrometer and know what you are about?” he asked Old Man Jones. Then being a decent sort of chap and seeing that he might as well have asked Jones why he did not keep an ichthysaurus in his backyard, he explained what a simple instrument a pyrometer really is.

“What you need in your shop is a thermocouple pyrometer,” said the inspector, “which is nothing more than a couple of wires running from an indicator and joined together within the furnace. When the joined end of the wires is heated, you look at the indicator and read off the temperature. The thing is really as simple as a thermometer and a good deal easier to read.”

### VARIOUS PYROMETERS AND AN IRISHMAN

There are a number of kinds of pyrometers besides those made on the thermocouple principle. Some depend on the pressure exerted by a gas inclosed in a tube. There is an accurate type known as the “resistance pyrometer,” which is a bit too complex for the average small shop. There are radiation and optical pyrometers which look like telescopes and are simply pointed at the hot objects. They are most suitable for work above 3,000 deg. F., for no part of the apparatus itself is heated.

The instrument shown at *H* in the illustration is an “expansion pyrometer.” It works on the difference of expansion of graphite and iron rods in its stem, and its upper working limit is 1,500-deg. F. I recall an experience with one of these instruments and with an Irishman named Pat, who was engaged to run the galvanizing department of a large upstate machine shop. The management of this plant had decided to have everything up to date and so got a pyrometer for Pat, without knowing that his education had not gone as far as reading either words or numbers. Pat, however, was too foxy an individual to give this fact away. Suspecting it and wishing to have a little fun with him, I asked him one day what temperature he was carrying on the galvanizing pot. Quick as a flash the answer came back, “Sure you have got spectakils on; you can see it twice as aisy as me!”

The thermocouple pyrometer, which is the one for the small shop, is made in a great variety of styles and in two general classes, portable and permanent. The first kind, as the name indicates, can be carried about from place to place and used to take the temperature of almost anything in the shop except a feverish haste. The second kind is installed in a lead pot, heating or annealing furnace or other place where it is desired to keep a continual check on temperatures.

### WHAT CONSTITUTES A THERMOCOUPLE PYROMETER

The parts comprising a base-metal thermocouple pyrometer are shown in the illustration at *K*. The arrangement does not look formidable, and indeed it is about as simple an instrument as could be devised. It consists of a couple of wires of unlike material which are twisted and welded together at one end. At the other end they are connected through an electric-wire circuit with a simple indicating instrument exactly similar to a voltmeter, except that it registers degrees of

## MAKING SMALL SHOPS PROFITABLE

temperatures instead of volts. When the welded end of the couple is heated, an electric current is set up by which the degree of heat may be measured. Fire ends are of two general kinds. One kind is known as the "rare metal" thermocouple and is used for the high temperatures between 1,800 and 3,000 deg. F. The other kind is known as the "base metal" thermocouple and is made of more common and less expensive material, which, however, will not do for continuous service over 2,000 deg. F.

The fire ends of thermocouple pyrometers are protected by sheaths of various materials, according to the service and the degree of heat. Porcelain tubes are used for the highest temperatures. In a lead bath an iron sheath or seamless-steel tube is used with a nickel-plated envelope above the surface of the metal to protect against vapors. Firebrick tubes are sometimes used for annealing furnaces, and graphite or clay tubes are used for measuring melted-metal temperatures. The protecting tubes should project into the furnace or the melted metal at least six inches.

### AT THE OTHER END OF THE WIRES

Two kinds of instruments are connected to the fire ends of either of the foregoing types—indicators, which indicate temperature, and recorders, which make a continuous graphical record similar to that made by a recording pressure gage or recording wattmeter. An instrument of each kind may be attached to the same fire end and will register its temperature simultaneously, one indicating and the other recording. Again a number of fire ends in various furnaces may be attached to the same indicator and recorder by means of suitable switches, so that one fire end at a time can be switched on the instrument, thus letting it take care of several furnaces, but of course only one at a time. Usually the indicator is placed so as to be easily seen by the furnace tender; while the recorder, which is a more delicate and expensive instrument, is mounted in the office or in a protecting cabinet.

The average small-shop man can get along without the recorder. A good base-metal indicating outfit can be bought for from \$25 to \$50. Additional base-metal fire ends will cost from \$3 to \$8 each. Rare-metal fire ends are four or five times as expensive. Fortunately, for most shop use the base-metal fire end will serve, leaving the more expensive kind for the foundry, which can quickly make up its cost by rapping the patterns a little harder!

### MAKING THE SHOP PYROMETER BEHAVE

Even the ordinary mercury thermometer, on which we base our opinions of the climate, is likely to err. So it must not be supposed that a pyrometer, which is subject to such a high limit of temperature, will do its work day after day without attention. Portable pyrometers which are used occasionally do not change very quickly, but those which are subject to constant heat must be looked after at regular intervals.

Nine times out of ten when there is anything the matter with a pyrometer, it is in the fire end. It may be due to a faulty connection at the end of the couple where the instrument leads are attached, or to too hot a "cold end," but it is much more apt to be because heat and gases have affected the "hot end."

The prices of base-metal fire ends are so reasonable that the small-shop man can afford to have a half-dozen

of them in stock, keeping one as a reference with which to check up the accuracy of those which are in daily use. Checking consists simply in connecting the two fire ends to the same source of heat and to the same indicator with a double-throw switch on the circuit so that alternate readings may be taken on each fire end with the same indicator. Of course the readings should be the same; but if there is any difference, the correction can be made. Fire ends which are in constant use at a temperature of 1,500 deg. F. should be tested once a week, and those which are subject to a constant temperature of over 1,500 deg. should be tested daily if accurate readings are desired. If out over 20 deg., the fire end should be annealed from one to five hours at a temperature of 1,472 deg. and then retested.

Another way of checking up thermocouple pyrometers is by the use of what are called "sentinel pyrometers." These are small cylinders approximately  $\frac{1}{2}$  to  $\frac{3}{4}$  in. which melt at different temperatures ranging from 400 to 2,400 deg. F. Below 932 deg. they are inclosed in glass tubes so that they may be used over and over again. The higher-temperature sentinels are set in porcelain saucers and are also used repeatedly, being caught in the saucer when melted. Placing a number of these in the furnace with the pyrometer, watching when they melt and noting the indicator reading at the same time will give a very good check on the accuracy of the pyrometer.

There are other methods of checking thermocouple pyrometers, one of them being by the melting or freezing points of metals such as tin, lead, zinc, aluminum, salt and copper; however, for the small shop the sentinel pyrometers are more convenient and likely to give more accurate results.

### TAKING CARE OF THE COLD END

The amount of current flowing is determined by the difference in the temperature between the hot end and the cold end, which latter is kept at a certain average temperature, or else corrections are made for any differences in temperature above or below that for which the cold end is set. There are various ways of taking care of the cold end of a thermocouple pyrometer. One of these, practiced by the Bristol Co., is to make the thermocouple element long enough so that the cold end is extended outside of the furnace down near the floor level, where the temperature does not vary a great deal. The Hoskins Co. in some cases recommends the use of a water-cooled cold end, and instruments of other concerns provide a compensator for adjusting for differences of temperature at the indicator. A fairly good way is to bury the cold end under ground. Don't have it where a draft of cold air is likely to blow on it. Don't locate it so that heat from the furnace or melting pot will be able to affect its temperature. A little care about these things will save "cuss" words later on.

The small-shop man who uses the same amount of intelligence with his pyrometer that he does with his micrometer will find it the means of getting uniform heat results which will better his product. He will not have much trouble keeping the appliance in good working shape. He will find it accurate, reliable and long-lived—unless he does as they tell of one pyrometer purchaser, who stuck the indicator in the furnace and tried to get the fire-end sheath off so he could read the "dommed thaymometer" inside!

# Painting Small-Shop Products—I

BY JOHN H. VAN DEVENTER

---

*SYNOPSIS—This article is one of a number that will deal with methods of painting and finishing products made in the small shop. In this issue the desirability of good finish is described, and points are given on the selection of colors and the preparation of castings.*

---

"If you wish to enjoy a funny show at the theater, don't let an optimist tell you about it in advance."

Dave Hope was responsible for this bit of wisdom, and said that it is human nature to like an agreeable surprise not only in matters of pleasure, but also in business. Rather a funny way for him to answer my question about painting and finishing small-shop products, I thought at first, but changed my mind after he went a bit farther into the matter and related a personal experience.

"Did you ever have a real swell salesman call on you," he asked, laying aside his surface gage; "one of the kind that wears patent-leather shoes and gray spats, fuzzy green hats and diamond scarf-pins?"

"About a month ago I was in the market for a new machine, and one of these birds flew in to answer my inquiry. He didn't have to announce himself, for his clothes were loud enough to speak for themselves. Before I had time to recover from the shock, he pulled out a leather cigar case, offered me a Ruy Elegancia and insisted that I take dinner with him at the Castor House.

## AN ELABORATE CATALOG IN EMBOSSED LEATHER

"After we had eaten about four dollars' worth, and the waiter had made off with the remains of the fivespot, my fancy friend got down to business. He pulled out an elaborate catalog bound in embossed leather and began to show me the pictures. First was a bird's-eye view of the factory, and over the page a front elevation of the executive offices, with gardens and automobiles attractively arranged in the foreground. On another page was the interior of the president's private office, done in mahogany with tapestry hangings. After I had sufficiently admired this elegance, he turned to the secretary's sanctum, the stenographer's studio and the directors' room. Next he called attention to the designing department and engineering office, each the last word in finish and equipment. Coming to the factory, he pointed out the recreation and lunch rooms and also the first-aid department, with its white-enameled furniture and its white-upholstered attendants. A few more pages brought us to the chemical and physical laboratories, with bottles and test-tubes and ovens and thermometers arranged for 100 per cent. efficiency. Next came some elegant views of the foundry and various shop departments, the latter having individual motor drive and electric transportation trucks.

"Finally we got to the last part of the book, where it said a few words about what they made in the plant; but the poor fellow was all tired out by this time, so that I had to pick out the machine I wanted and sell it to myself.

"Two days later I received an engraved card thanking me for the order and promising shipment within three

weeks. Ten days after that the shipping bill arrived, and along with it was a book of instructions about operating and taking care of the machine. That book was a work of art, printed in three colors and containing some of the slickest pictures you ever saw. Mrs. Hope made me keep it on the parlor table.

"I could hardly wait to get the machine from the freight house and rip off the crate and packing paper to see the slick piece of work that such an uptodate and enterprising firm must have produced.

## FEELING LIKE A NICKEL'S WORTH OF RADIUM

"Say, you could have swapped me for a nickel's worth of radium when I saw that machine. Foundry sand was sticking to it here and there; and from the looks of the sloppy single coat of machine-gray paint, a bush-league painter's apprentice must have thrown a brushful of paint at the thing from center field, and almost missed the mark at that.

"I wrote a letter to the firm, asking them if that was the regular finish on their machine, and this is what I got in reply," exclaimed Dave, fishing a letter out of his pocket:

Dear Sir—In reply to yours of Jan. 6, with reference to the finish on machine shipped on your order No. 776 beg to state that this is our regular finish.

Our policy in this respect is to embody the highest mechanical skill in building these machines; and since fancy painting will not make it operate any better we prefer not to sacrifice quality for looks and therefore keep down expense on this less important feature. Yours very truly,

BLANK MACHINE WORKS.

"And here is my reply," said Dave, handing me the following letter:

Gentlemen— I have noted what you say with regard to finishing your machines.

I am not a stickler for style, but if a man whom I know to be in comfortable circumstances pays a call at my house dressed like a dilapidated hobo, with dirty face and hands, he won't get any farther than the kitchen steps, no matter how many engraved advance calling cards he has sent me.

I take as much pride in my shop as I do in my home; and while your machine has good working qualities, its poor finish has caused me to install it in a dark corner where I hope no visitors will see it. Yours very truly,  
DAVID HOPE.

## EFFICIENCY HAS NOT ELIMINATED HUMAN NATURE

A few large shops have built up purchasing organizations that can lay aside all thought of anything except the ultimate dividend-earning capacity of a proposed purchase. They don't care whether a machine is pink, green yellow or black, as long as it will operate with a certain guaranteed efficiency on a certain product for a certain number of days in the year. Those who build things that are bought only by such concerns do not need to add fine finish as a selling point. But remember, where there is one purchaser who comes in this class, there are nine hundred and ninety-nine others not so far advanced, who look upon the purchase of each machine as a red-letter event—something to be thought about a long time in advance and admired for a long while afterward. Give a man of this type an article that he can be proud to show as well as to use, and he will go out of his way to boost it.

Science has done a good deal during the past few years, but it hasn't succeeded as yet in making a silk purse out

## MAKING SMALL SHOPS PROFITABLE

of a sow's ear nor a well-finished machine—a durably finished one—from poor castings. Holes can be plugged with filler, and foundry sand covered with pigment until the surface is perfect to all appearances; but by and by a spot will scale off here and there, taking with it as many coats as have been applied and transforming an attractive machine into an imitation of a mangy dog.

The small-shop man as a rule buys his castings and is thus in a good position to pick and choose, much better than the man who operates his own foundry and who is tempted to use anything therein made that has a faint resemblance to the original pattern. In buying castings, usually from a large jobbing foundry, it is possible to insist upon and to get good, clean, smooth castings. If the people you deal with can't give you satisfactory castings at the right price, try someone else—sticking to one thing isn't always a virtue, as the fly remarked to the fly-paper. Therefore if you are aiming at quality finish, make sure of a fair start toward it in the matter of castings and have them sand-blasted.

Sand-blasting makes the best surface for paint or enamel that can be had. The small shop with a sand-blast apparatus is an exception, and I should not advise installing one in such a shop unless conditions are quite unusual and there are a number of other profitable uses for compressed air. But the jobbing foundry of any size that has no sand-blast apparatus is also an exception, and thus the small-shop man may have sand-blast cleaned castings if he calls for them.

### GETTING PICKLED HAS ITS DISADVANTAGE

Some shops get clean castings by pickling them in an acid dip. The solution that is most commonly used for cast iron is one part of the commercial sulphuric acid to eight parts of water. Pickling will remove the scale and sand, but has the disadvantage that some of the solution may remain in the pores of the casting, resulting in the painted surface flaking off in such places. It is not enough to wash the pickled casting in water if this catastrophe is to be prevented; the acid must be neutralized by an alkaline solution such as sal soda dissolved in water in the proportion of  $\frac{1}{2}$  lb. to the gallon, preferably kept and applied hot. This in turn must be washed from the piece with water, alkali not being any more friendly toward paint than it is toward oil or grease or acids.

Assuming that the small-shop man has by hook or crook, luck, sand-blast or pickle secured a fair start toward a fine finish by getting smooth, clean material, what further steps he must take will depend on whether he is going to brush, dip or spray; whether the finish is to be dull, semi-gloss or full gloss; whether it is to be air dried or baked, and somewhat upon the color.

### COLOR AFFECTS THE SALE OF MACHINES

Color is a more important thing than a great many imagine, as applied to machine finishing. A pea-green lathe or a bright-yellow miller would have small chance of leaving a jobber's display floor, whereas these same bright colors are favorable to disposing of hand pumps and farm tools. Black is the color of dignity; the machine shop must be a dignified place, judging by the color of its equipment—if you find it too oppressive, take a walk into the engine room and have a look at the frivolous red engine.

The choice of color that will make an article salable is far from being simply a matter of good taste. It really

calls for a mixture of genius and a deep knowledge of psychology, diluted with considerable good luck. It is easier to tell what not to do in this matter than to say what should be done. For one thing, do not depart too widely from what has been more or less accepted as general practice for the product. Make it similar, but better. A pioneer in the choice of colors has a hard row to hoe. When in doubt, paint it black, for this color in paint as well as in clothes is suitable for all occasions.

### GREEN AND YELLOW BRINGING HOME THE BACON

The painting of articles for export is an art in itself, especially where the goods go to tropical countries. This is not because of the difficulty in getting a finish that will stand the heat, but of getting one that will suit the natives. Having at various times been connected with two factories making quite different lines of mechanical goods, both of which had large sales in South America, I am in position to pass out a bit of advice that is the result of observation. If you make machines for this trade, paint them bright green with yellow stripes and decorate the larger surfaces liberally with florid transfers; then you are sure to make a killing. This may sound like a joke, and in fact the machine thus treated looks like one; but notwithstanding this, green and yellow will bring home the bacon from South America.

The choice between dull finish, semi-gloss and full gloss is not as difficult as that of the proper color. Size has a good deal to do with this. A large machine or surface looks better with the dull finish, largely because this tones down all large irregularities or waves which cannot be corrected by applying filler. Semi-gloss, or eggshell, finish, while taking considerable skill to apply properly, is effective for medium-sized machines where cast iron is the main material, and has the advantage of not showing splotches of oil. Full gloss, or enamel, finish is most effective on small articles such as may be made part of a machinery jobber's window display; when well executed, this finish will help to attract the eye of a possible customer.

### FINE FINISH MUST BE CONSISTENT

To be really fine, the finish selected must be consistent with the use of the machine or part, in other words must serve some purpose aside from mere decoration. It is disappointing, to say the least, to buy an engine or pump attractively painted and then have its color darken and turn dead and muddy when the thing is subjected to its working heat. Nor is it altogether pleasing to have a tool that is meant to be handled shed its coat like a locust. Japan and baked enamel finishes have reasons for use other than to simply give the article a shiny appearance. Resistance to heat and resistance to handling are among the reasons for the employment of these more durable finishes, which, it will be found, are not beyond the reach even of small shops.

Protection against rust is one reason for painting those parts of machines that do not show—here the ornamental side is forgotten altogether and the purpose becomes strictly utilitarian. The interior of oil chambers of bearings are painted with another purpose in view—to keep sand from the cast surfaces from dropping into the oil and thus damaging the bearing. A paint made of red lead and linseed oil is best for this purpose, not being softened by lubricating oils.

# Painting Small-Shop Products—II

BY JOHN H. VAN DEVENTER

---

*SYNOPSIS*—Brush painting and air drying of the painted articles comprise the process most common in the small shop. This article describes various methods of applying filler, flat finish, semigloss and full gloss. It also gives practical points in caring for brushes and securing freedom from dust.

---

There is an unfortunate and very general tendency to use paint as a means of covering up defects instead of regarding it as a means of emphasizing high-quality workmanship. A manufacturer of small hardware, for example, will tolerate sandy castings, with the expectation that Old Doctor Paint will apply his universal remedy for rough surfaces and make a healthy specimen out of each decrepit invalid. Wrinkled and scratched products of the drawing press get by, in the hope that they will become respectable and presentable beneath a few coats of black japan. Certain products of the woodturner's art (or, rather, lack of it) go into the dipping tanks fringed with wooden whiskers that must be rubbed off by the painter, who is thus forced to add the profession of barbor to his other accomplishments. This policy has made machinery painting much more expensive than it needs to be, because both painter and paint must do work that has been left undone by someone else. They are the ultimate correctors of all the sloppy jobs that go through the shop.

How much more does it cost to produce a smooth casting in the foundry than to make it smooth in the paint department? Balance the cost of good facing and a few moments' slicking of the mold against the cost of knifing on two coats of filler and currying them with sandpaper and rubbing bricks. How much longer does it take to get smooth products from the drawing press than scratched and wrinkled ones? How much longer does it take to sandpaper wood turnings in a tumbling barrel before they are painted than to rub down the irregularities after the first coat? Getting these things right in the first place costs less in money, but more in care—which is a scarce article in a good many shops.

## WHAT CONSTITUTES A PAINTING DEPARTMENT

A small-shop painting department may be a simple or an elaborate affair, according to its needs. But to be a success, it must be regarded as a real department, even if the equipment consists only of a putty knife, two brushes and a few cans of paint. It must be regarded as an institution worthy of existing for what it does, and not as a necessary but unpleasant evil. And for the same reason, the work of painting should be done by the same man, even if there is not enough of it to keep one man continually busy. This is the only way that real interest in the work can be created and maintained, and interest is as essential a part as is the paint can or the brush.

One of the greatest handicaps to a good painted finish is dust. A machine shop is sure to have plenty of it on hand at all times, no matter what other commodity is short. Fresh paint and varnish seem to attract it as a magnet draws iron filings, with the difference that the

filings can be removed, but the dust cannot. It sticks, and spoils the finish.

There are two ways of overcoming the dust disadvantage, both of them based on not letting it get on. The easiest and most common way, and quite naturally the one with lesser merit, is to shorten the drying time by the addition of drier, so that the period in which dust can settle and stick is decreased.

The second and better way is to have a separate room for painting, at least for the final coats. Don't throw up your hands at this point, Mr. Small-Shop Man—there are more ways than one of killing a cat or of making a paintroom. I have known small-shop owners with offices that were more ornamental than useful who moved their desks out into the shop, and their pails and brushes into the office, with beneficial results both ways. Sitting in an office chair does not buy the small-shop baby new shoes, and dust works less injury to bills payable than to painted products.

## COMPROMISING ON A CANVAS CURTAIN

In one shop, where it was felt that a separate room for painting could not be provided and yet the necessity for it was known, a satisfactory compromise was made by providing a canvas curtain that partitioned off the assembling floor from the rest of the shop. The curtain was kept rolled up until required; when dropped down while painting a machine, it had a noticeable effect in decreasing the amount of dust.

Dust works its way through shop ceilings; and when this condition must be avoided, the ceiling may be either filled and painted, thus stopping the cracks and the dust leakage, or it may be covered with sheet iron, provided the fire-inspection regulations will permit.

The dust which settles on a coat of paint that has dried sufficiently to lose the quality of stickiness should be removed before the next coat is applied. It would seem that this is so self-evident as to be hardly worth mentioning, but it is a precaution that is overlooked in many shops. Compressed air is the best dust remover, and a hand bellows will act as an air compressor and hose combined in the shops that do not have compressor installations.

Much could be said on the subject of the proper size and kind of paint brush to use for a given purpose and a given paint; but you will find that experienced painters have different views in the matter, and even among them there is little agreement. No scientific study of this subject seems to have been made, and little, except opinions, can be offered. There is one thing, however, that is beyond contradiction—the size of the brush should be in proportion to the size of the work. By size is meant paint-carrying capacity. An oval brush will carry more paint or varnish than a thin flat brush that is wider in dimension. A brush is really a paint conveyor working back and forth between the pail and the painted surface, and the fewer round trips that it must make to cover the job the higher will be its conveying efficiency. As far as helping to produce a smooth finish, the brush itself is of little importance, properly dipped work being as excellent in this respect as the most skillfully applied brushwork.

## MAKING SMALL SHOPS PROFITABLE

The matter of caring for brushes has been much more definitely worked out. It was my privilege recently to hear the views of Carl J. Schumann, of the Moller & Schumann Co., Brooklyn, on this and other points relating to metal finishing. In the matter of caring for brushes this firm has evolved what it calls a "brush keeper," which is a closed metal can in which brushes are held suspended in a solution of linseed oil and turpentine. The brushes are placed in this can after being properly cleaned in clear turpentine. Thus they are kept in first-class condition, ready for use. The instructions for using this device are as follows:

When through using your brushes, rinse them thoroughly in turpentine, then put into the brush keeper.

In the brush keeper use a mixture of about four-fifths raw linseed oil and one-fifth turpentine. As the oil shows signs of thickening, which practically means that the turpentine has evaporated, add more turpentine.

Empty and clean out the keeper at least once a month. Strain the contents through two thicknesses of cheese cloth and make good any deficiency with a mixture in the same proportions as the original.

When brushes hang in the keeper, make sure that they are at least 1 in. clear of the bottom and also clear of the sides and of each other.

Rinse the brush in turpentine after taking it from the brush keeper; and before putting it into the varnish cup, discharge the turpentine from the brush by drawing it once or twice across the wire, then shaking briskly.

Fill the brush with the varnish in the cup, draw over the wire once or twice, immerse again in the varnish and let it stand for a short time. The brush is then ready for use.

Keep the varnish cup at all times protected from dust.

### CLOSED PAINT CANS ECONOMIZE ON MATERIAL

Waste and evaporation take a greater percentage of paint in the small shop than in the large one. A can of paint may be used one day and then set away for a week, often without being tightly covered. This is especially true of those cans which are opened by cutting the top. A simple cure for this waste is at hand in all shops and costs nothing. If you are up against a case of this kind, put a sheet of paper over the top of the can, fold it down over the sides and tie a string around it. It will look like an old-fashioned can of mother's marmalade, but the contents will keep indefinitely, so appearances may be overlooked.

The customary method of applying filler by knifing it on the casting requires a fair degree of skill to produce a smooth job. A better way in the small shop is to use the "benzine" process, which is as follows: The filler is first reduced with turpentine to a stiff paste, using a round brush. A second and a third coat are applied in the same way, before the first coat has had time to dry. Three or four hours are then allowed for the filler to take hold, after which it is rubbed down with a piece of heavy felt soaked in benzine.

It is quite a common belief that priming, filling and rubbing are essential to a high-grade finish. Some machinery builders proclaim in their catalogs that their machines are given so many coats of filler and rubbed down after each coat, as if the application of filler and the elbow grease necessary to rub it were things that no self-respecting high-grade machine could do without.

If the notion that finish is a covering of imperfections, as mentioned in the first paragraph, did not exist, you would hear less about the primer and filler. Defective and rough surfaces necessitate filler, and this in turn calls for primer to make it stick. If you attempt to fill a porous surface that has not first been primed, the result will be disastrous, as the binding element in the

filler will be absorbed, leaving it without adhesive power and likely to flake off, carrying with it whatever paint and varnish have been applied. Neither primer nor filler is a necessary part of a good finish—neither of them adds one bit to its quality. Both are substitutes for a suitable surface on which to apply color and varnish. If you have the smooth surface to start with, no amount of these substitutes will better the finish; in fact, they will make it worse, for two coats will very often stick better than six. We cannot do away with filler and primer on many kinds of work, but at least we can give them their proper value as defect and roughness coverers.

### THREE CLASSES OF BRUSH FINISH FOR MACHINES

There are, omitting black asphaltum and other more or less temporary coatings, three classes of brush finishes for machine shop products. These are the flat, the eggshell, or semigloss, and the full-gloss finish. The suitability of each of these for certain classes of work was mentioned on page 41, in the preceding article. Priming and filling, when necessary, are the same, no matter which of these final finishes is to be used—which is another argument for regarding priming and filling as restricted to the preparation of the surface for finishing and not as a part of the finishing itself. In describing these three finishes I will assume that this preparatory work has been completed and that the surface is ready for color.

A flat finish may be obtained in one coat of color, but it will not be anything to brag about. Two coats, however, will produce a first-class flat-finished job, providing the materials used are of good quality. Give the first coat 24 hr. to dry, whenever possible, even if it means holding back the shipment one day—the customer won't kick if you come that close to keeping your promised date. In this connection beware of paint bargains.

The semigloss finish requires more skill to apply and get right than either of the others. The coat underneath the eggshell or semigloss must be impervious, as otherwise the soluble matter in the semigloss is absorbed in spots and the result is crude. A coat of full-gloss enamel will provide the necessary surface on which to put the eggshell finish, but it must be allowed to dry thoroughly before this finish is applied.

Full gloss can be obtained in two coats of enamel. Usually, a "first-coat enamel" and a "finishing enamel" are applied, the supposition being that these two must be of different composition to produce the best results. This is another of those wrong guesses, for equally good results can be obtained by using finishing enamel for the first coat, thinning or reducing it with turpentine. It does not pay the small shop to stock first- and second-coat enamels, the wastage and extra investment more than making up for the slightly greater cost of the finishing material.

The expense of applying brush finish and the length of time required to air dry put a limit to the number of coats that can be applied under these conditions. A first and a finishing coat of good quality enamel will produce a full-gloss finish that will reflect credit on the small-shop product, unless it is a machine of such high grade as to require a number of coats, with each one rubbed. When that is the case, however, one must look to dipping and oven drying for means of shortening the time and labor, as otherwise the shipment of small-shop products would be sadly delayed.



# Painting Small-Shop Products—III

BY JOHN H. VAN DEVENTER

*SYNOPSIS—While brush painting is the most common process of finishing small-shop products, dip-tank finishing should be studied. It is within the reach of the average small shop and saves labor. The use of dip tanks is described in this article, which also touches on oven drying, spraying, and tumbling.*

Dip-tank finishing is a subject that the small-shop man needs to know more about. Paint, primer, filler, enamel, japan and varnish can be dipped, although there are limitations coming from a design of the piece; but where this process can be employed, it not only saves labor, but is likely to give smoother results.

Work that contains holes or recesses from which the accumulated paint will drip upon other surfaces is not suitable for dipping. An example of this is shown in Fig. 1 at *A*, in which the cast-iron stove plate has a number of central depressions. If it is dipped and then

are good dipping colors; but olive green is a bad one, because it is composed of different pigments, which have a tendency to separate in the tank and give streaky effects.

Small-shop products are not, as a rule, large or complicated. Dipping tanks are so easily made that there is no excuse for their not being suitable for the work. A good dip tank has the least area of its contents exposed to evaporation and also contains a minimum quantity of paint. The evaporation from the surface of a dip tank causes considerable loss of material and also of time in keeping the solution at its proper consistency. A flat piece, for example, may be dipped either in a shallow tank, as shown at *B* in Fig. 2, or in a deep, narrow tank, as shown at *C*. The first way would be expensive in paint; although the first cost of the tank would be less, evaporation and waste would soon make up for this. Steel window sashes are dipped on this principle in tanks that are 6 to 10 ft. deep and only a few inches wide.

When a tank is designed to present the least surface area, it follows that the minimum amount of paint for

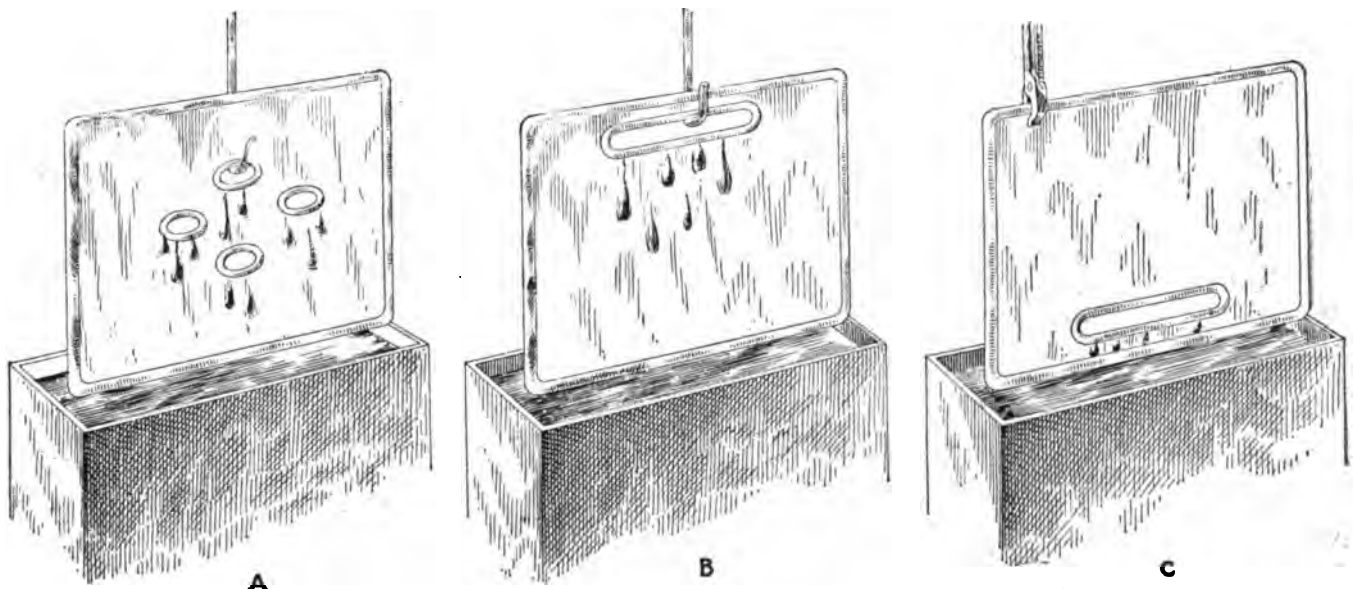

FIG. 1. THE SHAPE OF THE PIECE AND THE WAY IT IS DIPPED ARE IMPORTANT FACTORS

allowed to drain, drops will run down from these holes, and the result will be a smear. Of course, it is possible to touch up such spots with a brush, but this takes away the low labor-cost advantage of dipping. It is much better to design the piece with this point in mind and thus overcome the difficulty without cost.

Sometimes work that cannot be dipped successfully in one position may be made to turn out all right by using a little commonsense. An example of this is shown in Fig. 1 at *B* and *C*. Here is a steel plate having an opening, not at the center, but near one edge. If it is held and dipped in the position shown at *B*, the result will be even worse than in the foregoing case; but by turning this piece around, as shown at *C*, one stroke of the brush will remove the drip between the recess and the edge of the plate.

In addition to the restrictions coming from the design or shape of the piece there are certain points to consider about the color to be used. Black, bright red and blue

successfully operating the tank is also reduced in proportion. Thus these two principles of good design for dip tanks are both obtained by simply trying to live up to one of them.

Many small-shop products may be dipped in tanks that are no larger than ordinary cooking utensils or paint pails. Such small pieces are dipped by hand, then placed on one edge on boards to dry. When the pieces become larger, mechanical handling is necessary. This fact restricts the process on large work to shops in which the production is great enough to call for the equipment and room required. An overhead monorail trolley is usually found in such a dip-finishing room. It is broken over the tanks, the short broken section being provided with means for raising and lowering, so that the piece may be run onto this section, be dipped, raised again and run off without undue loss of time. After dipping, it must be allowed to drain, so that the surplus paint, which is worth saving, comes back to the tank.

## MAKING SMALL SHOPS PROFITABLE

Some automobile manufacturers paint their wheels by dipping, then get rid of the surplus paint by rotating them. Centrifugal force throws the paint back into the tank. Such complicated apparatus is out of the question for the small shop, but the centrifugal principle may be applied on smaller pieces without much elaborate machinery, and with good results. It is a thing that is worth remembering.

One of the problems in connection with dipping is to keep paint from getting where it is not wanted. This requirement restricts the use of the dip process, especially on work that has a number of finished surfaces or holes. There are ways of getting around this point. Whether it is economical to use these expedients or not depends upon whether the time needed for using them plus the time of dipping will be less than the time of brushing.

Wooden plugs are often used to keep paint out of holes. Melted paraffin run over finished surfaces will keep them free from paint, but it must be removed by heating the article after the paint is dry. This scheme can be used only with air-drying paints, for if parts with

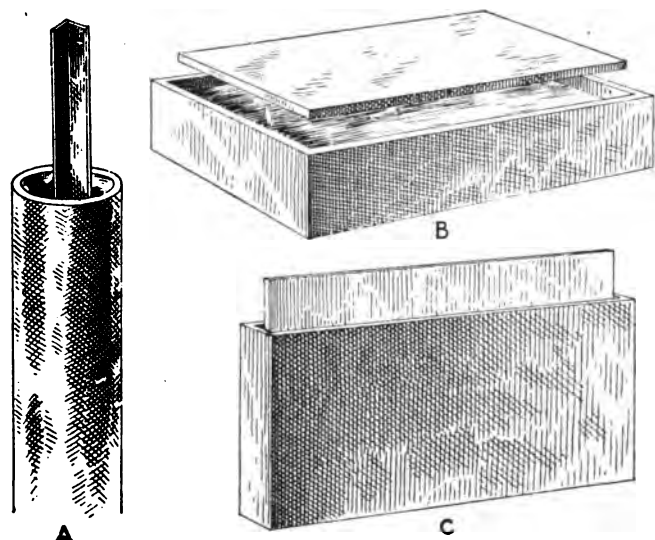

FIG. 2. THE DIPPING TANK MUST BE DESIGNED ON DEFINITE LINES

paraffined surfaces were put into an enameling oven, the wax would melt and run down and form a new and undesirable kind of finish. Hollow work, on which it is desired to keep paint from the interior, may be dipped with a closed end down, not being entirely submerged. After the piece is withdrawn from the dip tank, it is turned end for end so that the drip is downward toward the unpainted end, which is covered by a few strokes of the brush. There are hundreds of such expedients that may be used and that require only a little ingenuity and planning in advance.

A kink in connection with dipping has to do with obtaining a tag that will go through the dip tank without having its characters obscured by the paint. This problem presented difficulty to a manufacturer of small hand pumps and resulted in loss of time, because it was necessary for the man at the tank to remove each tag and fasten it on again after dipping. This trouble was overcome by the means shown in Fig. 3, which represents the product of a stencil-cutting machine. There is nothing about such a tag to become obscured in the dip.

The difference between air and oven drying is only a question of the degree of heat and the length of time

required. No doubt, an enamel finish-dried in the air for several months would be as hard to remove from the surface on which it was put as one that had been baked for a few hours in a drying oven. Ovens are therefore a means of hastening the process of securing a hard, durable finish. They are not complicated, and the temperatures do not run very high, 600 deg. F. being about the limit. As far as the small shop is concerned, there is nothing complicated about the process of baking enamel or japan. The only question is whether the quantity of pieces is sufficient to warrant the expense of the labor of handling them back and forth from the ovens.

Black japan, which one finds on typewriters, business phonographs, adding machines and a similar class of work, is one of the most durable and oil-resisting finishes that can be put upon metal. The finish secured with it varies from the plain two-coat finish for small and cheap articles to the seven and ten coats used on the higher-grade machines. On this fine class of work, each coat after being baked is sanded, or rubbed with pumice, and often on work that has been stripped or gilded a protecting coat or coats of varnish are applied and baked.

Japan finish is always black, but colors are obtained by the use of enamels that are baked in the same way. The number of coats for enamel finish varies with the quality of the work, but a very respectable job can be obtained with two coats. I recently saw a test piece

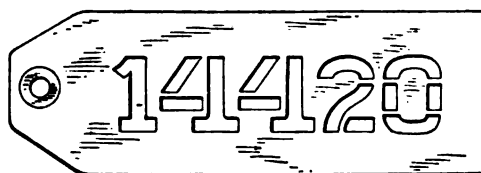

FIG. 3. PERFORATED TAGS ARE NOT DEFACED IN DIPPING

finished in two coats of enamel of ordinary quality. It had been submersed in kerosene oil for two years and showed no signs of softening.

Spraying is an ideal method of putting paint upon most surfaces, large or small. In small shops the lack of compressed air usually settles the matter at once and decisively. There are certain shops, however, which are small and yet have air compressors, and there are others in which the present method of finishing products would make it a paying proposition to install a small compressor such as is required for this class of work. Pressures as low as 14 lb. to the square inch are used, and as high as 80, painting, of course, going more quickly with the higher pressure. Filler, color and varnish can all be sprayed, but the consistency must be fixed so that the nozzle does not clog and paint does not run in waves on the work. It does not pay to spray work in which a large part is composed of open spaces—for example, bicycle wheels and wire.

Tumbling is suitable for small work that is to be japanned, where the quantities contained in the batch may vary from five hundred to fifty thousand pieces. Shoe buttons are an excellent example of this class of work, which it would be difficult to coat evenly, uniformly and as cheaply by any other method. After being tumbled for a certain length of time in connection with an amount of japan sufficient for the batch, the contents of the tumbling barrel are put on wire-mesh screens and baked in an oven. A number of coats are applied in this way.

# Caring for Small-Shop Bearings

BY JOHN H. VAN DEVENTER

**SYNOPSIS**—This article takes up some of the practical points in connection with the construction and operation of shaft bearings and tells how to make simple tests of the quality of the lubricant.

"How are you getting on with that perpetual-motion machine, Uncle Billy?"

"There is only one thing now left to be overcome, and then the machine will go."

"And what's that, Uncle Billy?"

"Oh, just friction."

Friction is the curse of the perpetual-motion inventor, and it is indeed more or less of a nuisance in the shop

a case of three, or even two, bearings on a bedplate. Unless the section of this plate is extremely rigid, any mechanic will know that it can be easily sprung out of shape to suit the lack of level or flatness level of the floor on which it is placed. It is almost impossible to line up three bearings upon a single shaft without producing more or less of this binding, which is the reason that the sale of flexible couplings is on the increase. Even the use of self-aligning bearings does not do more than make it easier for the shaft to bend under these conditions. The remedy in a case of this kind is to use a flexible coupling and self-aligning bearings, dividing the work between two shafts, as shown at *C* in Fig. 1. This arrangement costs more than the arrangement shown at

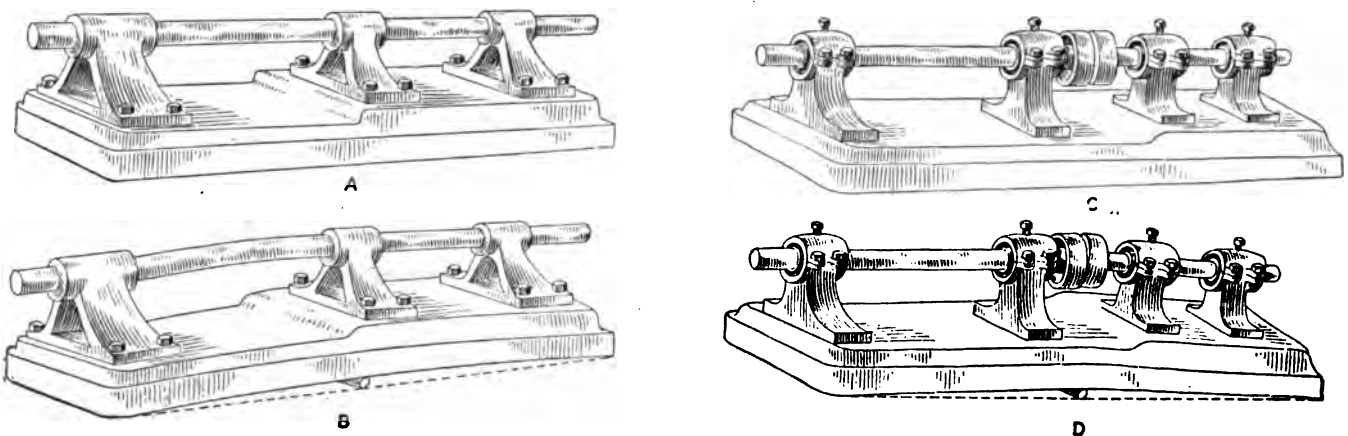

FIG. 1. SELF-ALIGNING BEARINGS AND A FLEXIBLE COUPLING MAKE BEARING FRICTION A MINIMUM  
A and B—three rigid bearings on one shaft are certain to result in loss of power. C and D—four self-aligning bearings and a flexible coupling increase the first cost, but pay dividends

anyway, except in the case of pulleys and belts, where it is quite desirable to have a fair share of it. Like all other evils, it has its uses; but like most other evils, it is easier to make use of its advantages than it is to minimize its disadvantages. And then if it weren't for

*A*; but the man who is going to use this outfit will pay the difference, if its disadvantages are properly explained to him.

Friction is blamed for a lot of things of this kind that really should not be laid at its door. As a matter of fact,

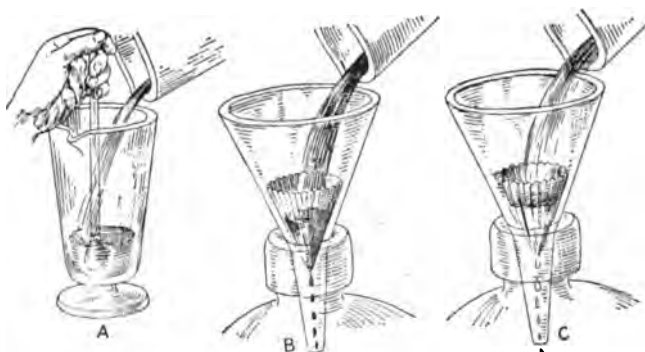
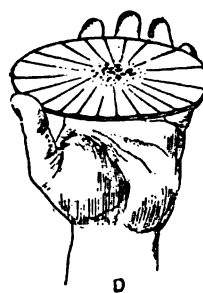

Fig. 2



D

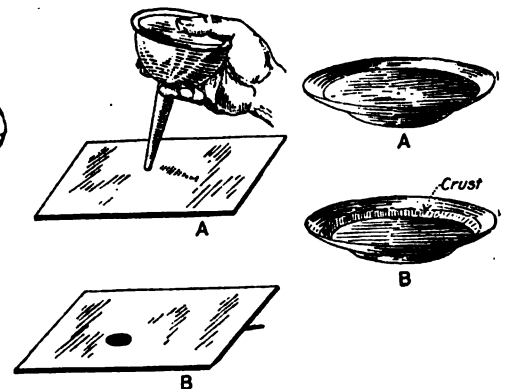

Fig. 3

Fig. 4

FIGS. 2 TO 4. VARIOUS TESTS OF OILS TO DETERMINE PRESENCE OF IMPURITIES

Fig. 2.—Testing oil for solid impurities. A—Thin the oil with kerosene. B—Strain through filter paper. C—Wash the oil through with pure kerosene. D—Examine the filter paper for a residue of solid particles. Fig. 3.—Testing oil for the presence of acid. A—Put a drop of oil on a polished brass sheet. B—a green spot on the brass after several days denotes acid in the oil. Fig. 4.—Testing oil for the presence of resins. A—Put some oil in a saucer and leave in a warm place for several days. B—If a crust forms, it shows the presence of resins

friction, the oil dealers would lose their jobs and the price of gasoline would go up another notch to keep up the general average.

A good deal of the friction that is ordinarily attributed to bearings is in reality actual mechanical binding. Take

the reason that many shafts run at all is because they possess enough flexibility to let them turn the corners imposed upon them by bearings that are out of line.

When a bearing heats up because something of this kind is the matter with it, conditions are wrong and

## MAKING SMALL SHOPS PROFITABLE

should be changed, but the mere fact that a bearing gets hot does not indicate that anything serious is the matter. A modern theory has it that the hotter a bearing becomes the more efficiently it runs and the less power it wastes in friction. If made properly, bearings can be run hot enough to fry an egg upon their surface, and yet this heat need not be the cause of alarm. However, this is true of the fast-running shafts that rotate one or more thousands of revolutions per minute. When the slower-moving small-shop bearings get hot enough for culinary purposes, it is time, ordinarily, to do something with them.

A hot bearing may be caused by lack of proper lubrication or by lack of sufficiently good workmanship, and sometimes, not infrequently, it is due to a lack of knowl-

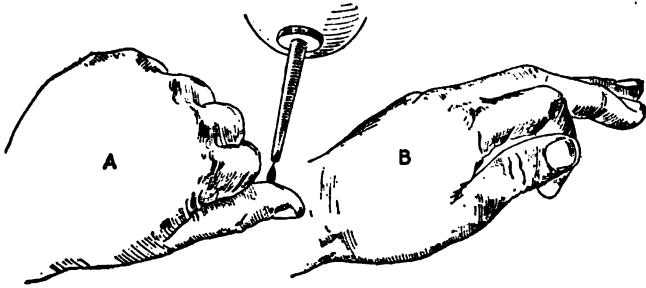

**FIG. 5. A SIMPLE SHOP TEST FOR VISCOSITY**  
A—Place a drop of the oil on the ball of the thumb. B—If you can squeeze out the “chummy feel” by rubbing a short time, the oil lacks lubricating qualities

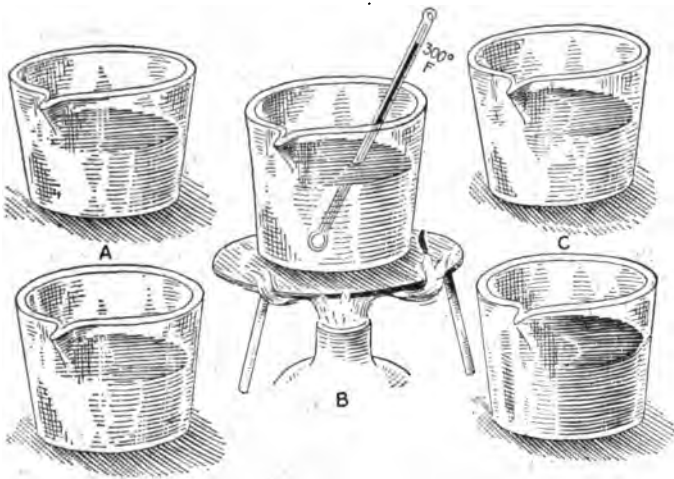

**FIG. 6. TESTING OIL FOR THE PRESENCE OF SULPHUR**  
A—Put a quantity of oil into each of two glass vessels. B—Heat one of the samples to 300 deg. F. and maintain this temperature for 15 min. C—If the heated sample turns darker than the original, it indicates the presence of sulphur.

edge on the part of the man who designed the bearing and who made it too small for the load. In the majority of cases, however, trouble is usually traced to a lack of proper lubrication.

Thus, the first and greatest rule in caring for small-shop bearings, and in fact any other, is to keep them lubricated with a lubricant of good quality, suitable for the work that they have to do.

Of course, there are people who simply will not oil a machine, out of general principles, I suppose, these people usually *not* being the ones who pay for the machines in the first place. Then there are others, and more of them, who do not neglect to oil machines on principle, but because of forgetfulness. The injury done by one of these fellows is as bad, however, and the aggregate damage is much greater. I have seen shops (and big

ones, too) where a machine that *was* in common use by a number of men went oilless because each one would look to the next fellow to oil it.

The crudest oiling device that exists is the “oil hole” to which oil is applied with a squirt can. The use of

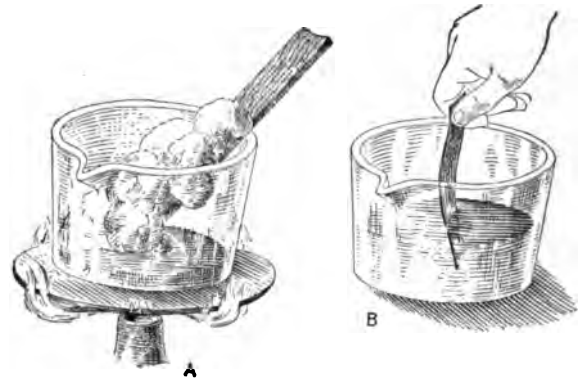

**FIG. 7. TESTING THE “NEUTRALITY” OF GREASE**  
A—Melt a quantity of the grease. B—Test with litmus paper. If blue litmus paper turns red, it indicates acid; if red litmus paper turns blue, it indicates alkalies. A very slow change of color indicates a neutral grease.

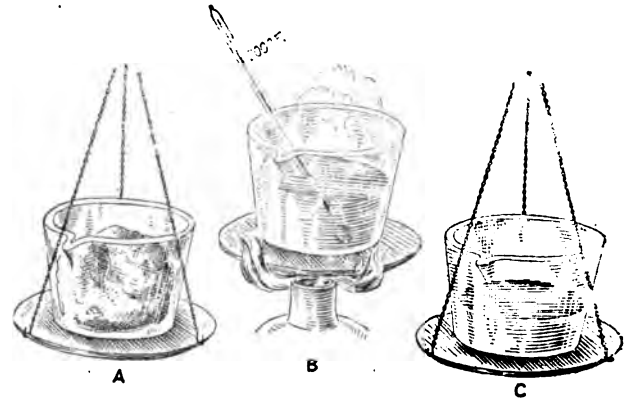

**FIG. 8. TESTING GREASE FOR VOLATILE MATTER**  
A—Weigh a quantity of grease on a sensitive balance. B—Heat at 200 deg. F. for 2 hr. C—Weigh again. The difference in weight is an indication of the amount of volatile matter, such as benzine, naphtha, etc., in the grease.

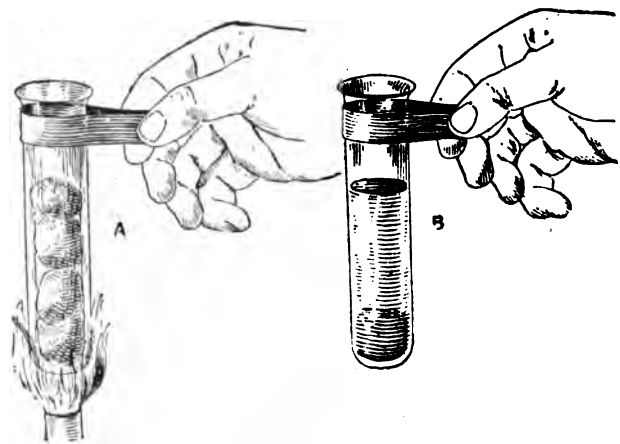

**FIG. 9. TESTING A GREASE FOR “FILLING”**  
A—Melt some grease in a test tube. B—A cloudiness at the bottom of the tube indicates soap or other filling.

the word “engine lathe” is almost a slander on the steam engine, for no matter how depraved and lost to hope be the designer of an engine he still retains a certain sense of shame that prevents him from totally ruining the design of his engine by providing for squirt-can lubrication. No, indeed, he puts on sight-feed oilers, even on farm engines in which the bearings are not scraped. What a pity to see excellent workmanship

wasted on hardened and ground spindles and high-grade bronze bushings such as we find in machine tools and then to think that the lubrication and like of these expensive bearings are left to the chance finding of a squirt-can hole! When you get a machine in which the important bearings have been mistreated in this way, do yourself a favor by tapping out the holes and adding sight-

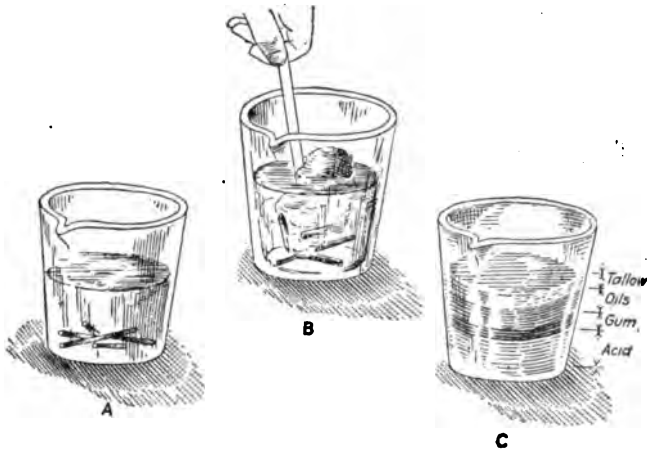

FIG. 10. TESTING GREASE FOR TALLOW AND GUMS  
A—Place some pieces of copper wire in a concentrated solution of nitric acid. B—Add some grease and stir. C—After an hour the ingredients will arrange themselves as shown.

feed oil cups, incidentally crediting yourself for this act by adding a couple of years to the probable life of the machine on your depreciation sheet.

An article of this length is a small place to cover the big subject of bearings, even for small shops. The man who is interested in the design and operation of bearings will find this subject fully covered in the "American Machinist Bearing Book." So I will use this space for pointing out certain simple tests for oils and greases—tests which need not be made in the laboratory, but which can be made in Mrs. Small-Shop Man's kitchen, if necessary.

### A Built-Up Limit Gage

By HENRY P. BOETTCHER

The cut shows a limit, or snap, gage which can be very easily and cheaply made and kept in repair. The central part, or body, *B* is first finished accurately to

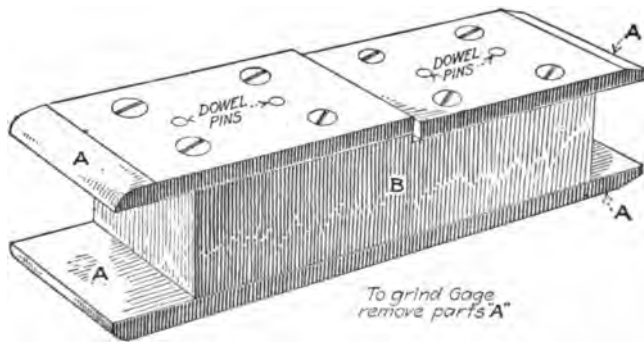

A BUILT-UP LIMIT GAGE

the desired measurement, and the parts *A* having the inner surfaces ground and lapped smooth are fitted and held in place by flush head screws passing clear through.

When the gage becomes worn all that is necessary to restore it is to remove the loose parts and straighten their inner surfaces on the lap.

### Special Form of Hollow Mill

By A. E. HOLADAY

Having a rush order for a quantity of iron castings with a  $\frac{3}{8}$ -in.-diameter wrought-iron pin cast in, and having in stock a sufficient number of these castings with a  $\frac{1}{16}$ -in. pin, we decided that it would be a good idea to mill these  $\frac{1}{16}$ -in. pins to the required size, there-

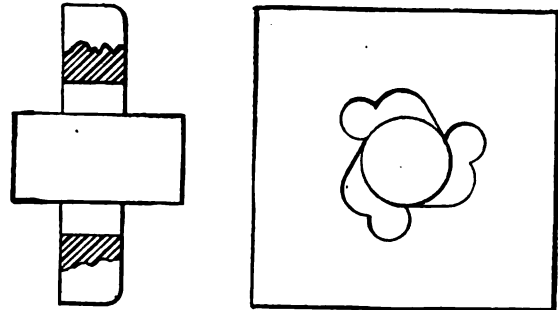

A HOLLOW MILL FOR WROUGHT IRON

by saving time in the execution of the order and also reducing an unnecessarily large stock. When we came to the actual milling operation, however, we experienced a vast amount of difficulty with the usual form of cutter owing to the nature of the material being worked.

After some experimenting the die shown in the illustration was evolved, it being practically a pipe-threading die without the threads. This tool was held in a four-jawed chuck on the lathe spindle and the work fed up by a collet in the tail spindle, the mill cutting very freely and smoothly as fast as the operator could advance the work.

### Radius Planing Tool

By F. E. ERVIN

The internal planing tool shown on page 380, Vol. 48, of the *American Machinist* is similar to a tool I have used for planing small radii. No clapper box is needed, as the cutter is placed just in front of this shank and thrust collar. A hole through the shank near the lower end receives the tool bar, the shank being split for some distance past the hole to allow for clamping the bar by means of the capscrew shown. A set-screw and hardened rod inserted from the rear end of the bar clamps the tool, which can be set to any desired radius by measuring over the bar with a micrometer.

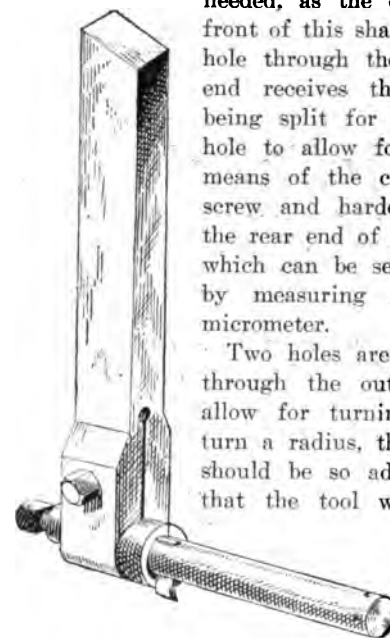

TOOL FOR PLANING RADII

Two holes are drilled at right angles through the outer end of the bar to allow for turning it with a pin. To turn a radius, the tension upon the bar should be so adjusted by the capscrew that the tool will not move of itself under pressure of the cut, but not tight enough to prevent it from being turned by means of the pin. Very accurate work can be done with this

tool, without the chatter that usually accompanies the use of formed cutters for the purpose.

# Methods of Locating Machinery-Foundation Templets\*

BY PAUL M. MEYERS

**SYNOPSIS**—A description of the needful equipment and the methods of using it in laying out machinery foundations and locating the anchor bolts. The methods include the application of the 3-4-5 rule, the measuring rod and the radius board.

When any machine which requires a foundation is to be installed it is frequently imperative and always desirable to locate accurately the anchor bolts in the foundation by using a templet. Where a new machine is to drive, or be driven by, some existing machine or appliance, it is usually necessary that the new machine be precisely located in relation to the other. This positioning obviously involves the correct locating of the anchor-bolt templet. In this article will be described some methods for locating templets, which practice has demonstrated to be satisfactory. Although the illustrations and descriptions relate specifically to small foundations, the principles involved apply to large and small alike. Small-machine installations are considered merely to insure conciseness of illustration and description. The

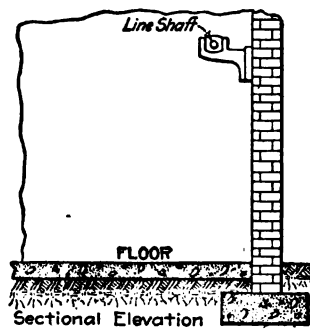
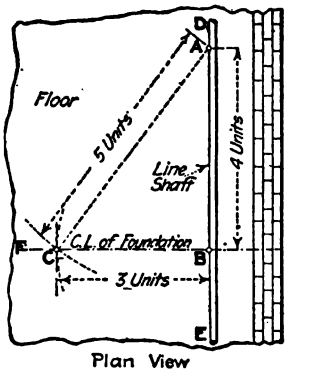

FIG. 1. APPLICATION OF 3-4-5 RULE IN LAYING OUT

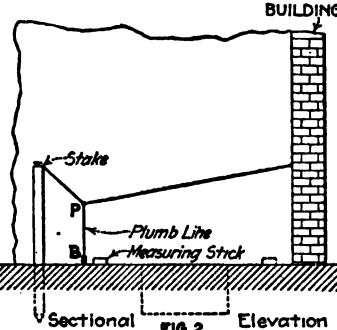
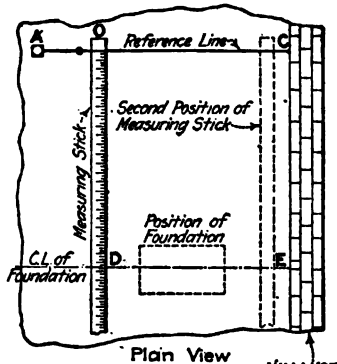

FIG. 2. METHOD OF ALIGNING TO TRUSS CENTERS USING A MEASURING STICK

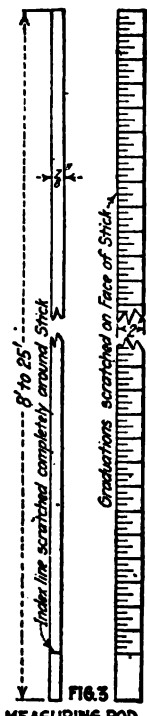

FIG. 3. MEASURING ROD FOR ALIGNING AND LAYING OUT

FIGS. 1 TO 3. METHODS AND DEVICES FOR LAYING OUT FOUNDATIONS.

necessity of accurate templet location is almost apparent. The location of the anchor-bolt templet determines the location of the machine which the anchor bolts are to fasten down. Thus it is essential that the templet be placed over the foundation excavation in such a position that the machine, after it is installed, will be at the correct elevation and in correct alignment with the other units to which it is related. Locating a templet means setting it in correct alignment (in relation to whatever is to drive, or be driven by, the new machine) and setting it at the required elevation. Grout is commonly used between the top surface of the foundation and the bed-plate of the machine; hence allowance should always be made for the thickness of grout in locating a templet as to elevation.

Locating a templet usually involves the location of at least two center lines of the machine—the longitudinal and the transverse. In addition secondary lines must frequently be located.

The laying off of one line at right angles to another is nearly always necessary in locating a templet. Therefore three practical methods involving the use of simple equipment for laying off such lines will be described. These methods are (1) with a cord by the 3-4-5 rule, (2) with a measuring stick, (3) with a radius board. Usually where a transit is available and the installation is a relatively large one, it will prove economical to use that instrument in projecting lines; but inasmuch as the methods of laying off angles with transits are well

understood by the men who use them, such methods will not be treated here. The method of laying off a right angle by the 3-4-5 rule, sometimes called the 6-8-10 rule, is illustrated in Fig. 1. It involves the well-known principle of geometry that if the ends of three lines proportional respectively in length to 3, 4 and 5 are joined together so as to form a triangle, the angle between the line which is 4 units long and the one which is 3 units long will be a right angle. Suppose it is desired to lay off a reference line in

the general direction of  $BF$ , so that it lies exactly at right angles to the direction of the line shaft  $DE$ .

A plumb bob is dropped down over the shaft from  $B$ , and the point directly under the point of the plumb bob is marked on the floor. The plumb bob is now dropped down at  $A$ , and a point indicating this location is marked on the floor. The distance from  $A$  to  $B$  should be just 4 units in length; that is, it may be 4 ft. if we take 1 ft. as our unit, or it may be 8 ft. if 2 ft. is taken as the unit. With radii of respectively 5 units and 3 units, arcs are now struck from the points  $A$  and  $B$ . These arcs intersect at  $C$ . They can be drawn by using a pencil, a piece of chalk or a nail tied at one end of a piece of cord and a nail tied in the cord at the correct distance from the marker, to act as a center. Then the line  $BCF$  through  $C$  will be at right angles to the shaft. The location of

\* Copyright, 1916, Hill Publishing Co.

## METHODS OF LOCATING MACHINERY-FOUNDATION TEMPLETS

this line may be preserved by stretching a chalk line over it, by marking it on the floor or by indicating the points of its course on walls, columns or girders.

The measuring stick or measuring rod, or measuring pole (it has various names in different localities), Fig. 3, may be used as shown in Fig. 2. For laying out lines at right angles to one another it is detailed in Fig. 4. It is merely a rod of clear-grained wood, preferably white pine, planed smooth on all four faces. It should be 2 in. or 3 in. wide, of  $\frac{7}{8}$ -in. stock and from 8 ft. to 25 ft. long, as conditions demand. An index or zero line should be scratched near one end of the rod, "squared" around on all four faces, and the rest of its length should be graduated in feet and half-feet, or in feet and inches. The graduations are marked on only one face of the rod. The rod should never be narrower than 2 in. on its wide face, because when it is used for laying out one line parallel to another the reference line (a string) lies over, and when the rod is at right angles it coincides with, the index line on the rod. If the rod be too narrow, the reference line may seem to coincide accurately with the index line when it actually does not. It is apparent then that, within reasonable limits, the wider the graduated face of the rod the more accurate will be the locations made with it.

Let us assume that it is desired to lay off a line from the point *C*, Fig 4, at right angles to *AB*, as shown in the first step. A stake, or pin, Fig. 5, should be driven in the ground or floor at *C*. Then a length 3 units long (usually 6 ft. in practice) *CD* is laid off along *AB*, as shown in the second step. Another pin or stake is driven at *D*. Now a cord *CM* is stretched from *C*, as shown in the third step, in a direction, as nearly as can be determined with the eye, at right angles to *AB*. Lay off a distance 4 units long (usually 8 ft. in practice) *CE* and drive a pin or stake at *E*. Batter boards or trestles should now be arranged, on which the measuring stick, Fig. 3, may rest while it is being adjusted. The trestles or batter boards should be as nearly as possible of such a height that the measuring stick when it is laid on them will lie just under the lines but will not touch them. Now swing line *CM* around *C* by moving *M* until the distance between *D* and *E* is 5 units long (usually 10 ft. in practice). The 3-4-5 triangle is completed, which insures *CE* at right angles to *AB*.

The radius board is an arrangement whereby right angles can be laid off with a minimum expenditure of time and labor. The arrangement, which is illustrated in Fig. 6, was, it is believed, first proposed by James F. Hobart and is described in his book, "Millwrighting." The device comprises two components—the marker board and the radius strip, Fig. 6. Almost any plank may be used for a marker board, but it should preferably be about 12 ft. long,  $\frac{7}{8}$  in. thick and 10 in. wide. It has a line *AB* scratched longitudinally along the center of one of its faces, which should be planed smooth. The radius strip is a wooden piece 2 in. or 3 in. wide, which has two nails *G* and *F* driven through it, one at each of its ends. The distance between the nails *F* and *G* may be

any desirable length, but 5 ft. is a convenient one. The nails should be so driven as to be at right angles to the wide faces of the strip. A hole *O* is now made in the center of the marker board. This hole may be made conveniently by driving one of the nails of the radius strip into the board. Then one of the nails *F* or *G* in the marker board is inserted in the hole *O* and the marks locating the points *C* and *D* are scribed, using the radius strip centered at *O* as a tram. The radius board is now completed and should appear as shown in Fig. 7.

The method of laying off a right angle with a radius board is shown in Fig. 7. It is assumed that it is desired to lay off a line, as *GZ*, at the point *G* at right angles to the base line *XY*. The assembled radius board is placed on the ground or floor or on a couple of battens or horses, as shown. Then with one nail *F* of the radius strip in position in the hole *O* of the marker board, the whole device is shifted until the other nail *G* of the strip is at the point from which the line at right angles to *XY* is to be projected. Now the trestles or battens are adjusted so as to lie directly under the board, and it is shifted until the point *B* lies directly under the line *XY*.

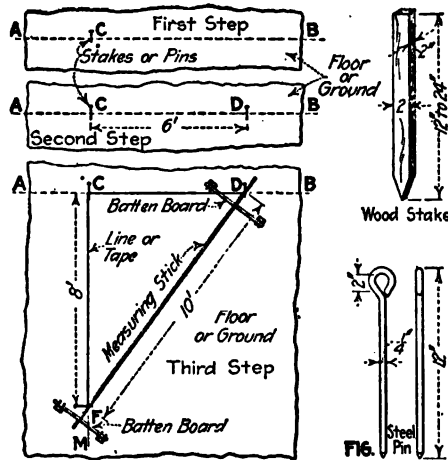

FIG. 4. APPLICATION OF 3-4-5 RULE USING MEASURING STICK

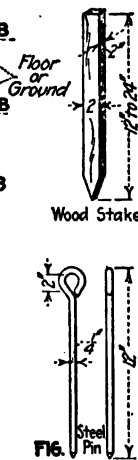

FIG. 5. WOODEN STAKE AND STEEL PIN USED FOR MARKERS IN LAYING OUT

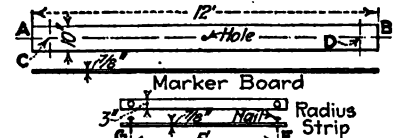

FIG. 6. CONSTRUCTION OF RADIUS BOARD

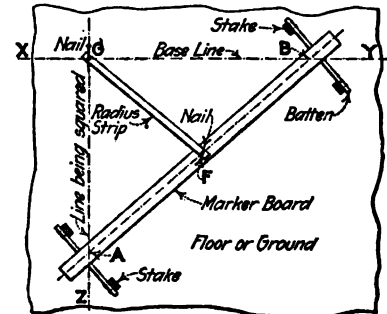

FIG. 7. METHOD OF USING RADIUS BOARD FOR LAYING OUT

FIGS. 4 TO 7. METHODS FOR USING MEASURING ROD AND RADIUS BOARD.

Then a line *GZ*, passing over the hole *A* in the marker board, will be at right angles to *XY*. The angle *AGB* will be a right angle regardless of the location of *B* along *XY*. However, it is desirable to maintain the distances *GB* and *GA* about equal, because this tends to insure maximum accuracy. Although in description this method may appear complicated, it is really very simple. In practice and doubtless provides the most rapid method for laying off lines at right angles to one another. The radius board is based on the geometric principle that any angle described in a semicircle is always a right angle.

The method of using the measuring stick to lay off one line parallel to another is shown in Fig. 2. Assume that it is desired to locate the center line *DE* of a foundation, it being necessary that *DE* be exactly parallel with some reference line *AC*. This reference line in the case shown is a cord which may be strung between the centers of two columns or between a stake and some other point. A plumb bob *B* is hung at a convenient location on the reference line. Then the measuring stick is placed on the ground or floor, in the position shown in Fig. 2, and its outer end is shifted around *O* as a center until, to a per-

## MAKING SMALL SHOPS PROFITABLE

son sighting with one eye from a position  $P$ , the index line on the measuring stick, the plumb line and the reference line coincide. Then the stick is at right angles to the reference line, and a mark is made on the floor at  $D$  at the required distance from the reference line. This operation is repeated with the stick in the position shown dotted, and the point  $E$  is obtained. A line through  $D$  and  $E$  is parallel to the reference line, at the correct distance from it and is a longitudinal center line for the foundation and the templet that is to locate it. Obviously the line  $OD$  must be at right angles to  $AC$ .

Typical examples illustrating methods of locating templates are given in Figs. 8 and 9. While these views show small (4-bolt) templates, the general procedure indicated is the same as would be followed for large machines. In each case it is necessary to locate a longitudinal and a transverse center line.

The method in aligning a templet to a line shaft is shown in Fig. 8, which illustrates the interior of a mill

distance  $ON$  similarly laid off. The cord  $LN$ , representing the transverse center line of the foundation, was drawn taut between the two stakes, located as shown. The templet was then adjusted over the foundation hole until the corresponding index lines on it coincided with the line  $LN$ . Then the templet was shifted until the distance  $JK$  measured from the truss center line was correct. It was then nailed securely to the stakes which had previously been driven, and held firmly in position. The elevation of the templet was determined by measuring up from the floor line, and it was adjusted until it was level in all directions. The boards composing the templet were purposely left long enough so that they would extend beyond the excavation and rest on the stakes for support.

The process of aligning a templet from a roof-truss center line is diagramed in Fig. 9. In this case a form was used for the foundation, and the templet, after being properly aligned and leveled, was nailed to the top edge of the form. The longitudinal center line of the templet

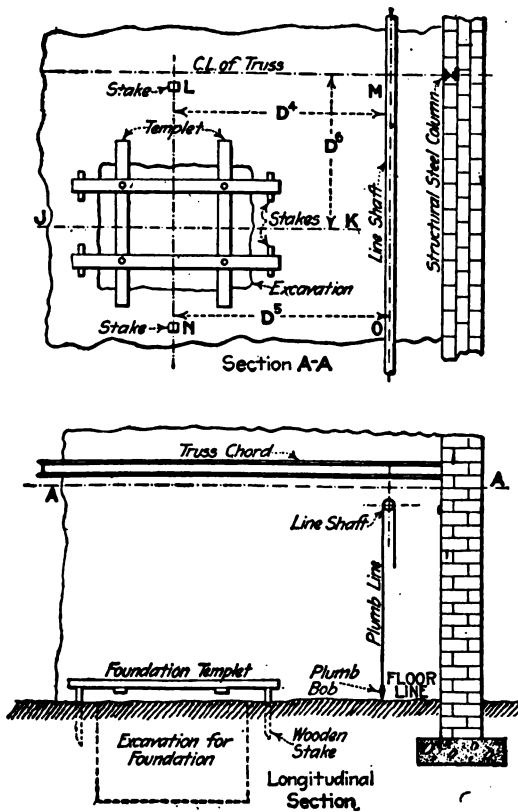

FIG. 8. METHOD OF ALIGNING TEMPLT TO LINE SHAFT

building where a motor to drive a line shaft is to be installed. The foundation center lines are located from the dimensions  $D^4$  and  $D^6$  distances from the center line of a roof truss and center line of a line shaft respectively. In the case illustrated the soil was so firm that no form was required for the foundation, the excavation itself constituting the form. Hence the templet, after having been accurately aligned in the manner to be described, was held in position by nails driven through it into wooden stakes driven into the ground. The procedure in aligning the templet was as follows: A plumb bob dropped over the line shaft indicated its location with reference to the ground. The plumb bob was adjusted at the point  $M$  and the distance  $LM$  laid off with a measuring stick (see Fig. 3). A tape line could have been used instead. Then the plumb bob was adjusted at  $O$  and the

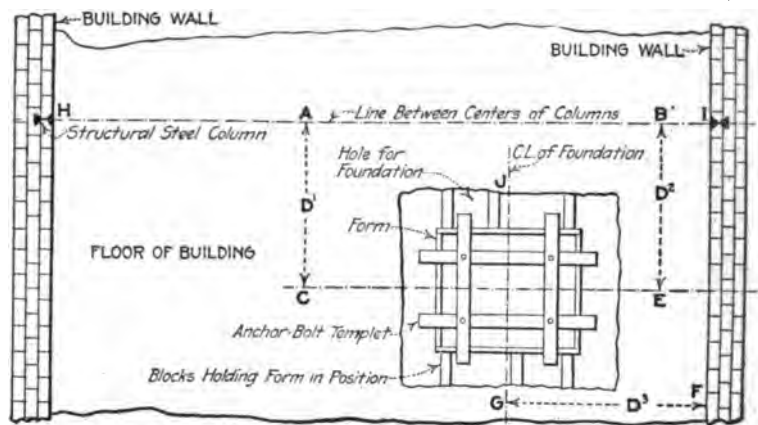

FIG. 9. METHOD OF ALIGNING FOUNDATION TO TRUSS CENTER

$CE$  was made parallel with the roof-truss center line  $HI$  by measuring the distances  $D^1$  and  $D^2$ . The distance  $D^3$  is from the inner face of the wall to the transverse center line. The distance  $D^1$ ,  $D^2$  and  $D^3$  were all specified on the erection drawing. All three of the center lines ( $HI$ ,  $CE$  and  $GJ$ ) are, in practice, taut cords. After the templet and form have been accurately located in their correct positions, blocks are wedged between the outer face of the form and the face of the excavation to prevent the form from shifting while the concrete is being poured. Sometimes, if the form is not worth saving, the space between it and the foundation is filled with earth before the concrete is placed, and the form is left in the ground.

## End Mill for Babbitt

BY A. E. HOLADAY

The illustration shows an end mill which has proved successful for machining babbitt or white metal. It is

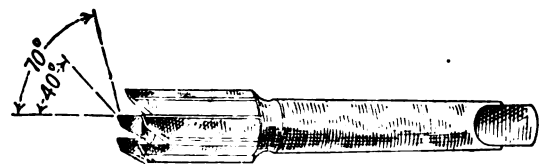

AN END MILL FOR BABBITT

a regular end mill with every other tooth cut back to the angles given. It was found not to clog up with metal as a regular mill does.



# Standardizing Shop Drawings of Machine Details

By A. C. SPENCER\*

**SYNOPSIS**—This plan is intended to relieve the drafting room of the large amount of duplication which is often considered necessary in the details of manufactured articles. It substitutes a form, printed on bond paper for easy blueprinting, and enables stock orders and instruction cards to be made by filing in a few blanks or crossing out unnecessary directions. A careful study of some of these forms should be helpful to many drafting-room heads.

The illustrations present a number of interesting examples of a plan for reducing labor in the drawing room by making it unnecessary to draw many of the details

universal application, as well as the surprising amount of detailed instructions which can be given with all necessary variations for different pieces. These variations are easily secured by crossing out unnecessary operations and putting in special figures wherever necessary, such as the length of time to be kept hot and the drawing temperature for pack hardening.

The actual size of the sheets shown is 6x8 in., although a larger size, 8x12 in., has also been used for some purposes. The sheets are printed on a bound paper in a printing press, and blueprints are easily made.

It will be noticed that the necessary stock is shown at the top of each sheet, as well as the list number of the sheet in the upper right-hand corner. An outline of the piece, not drawn to scale, gives all necessary dimensions,

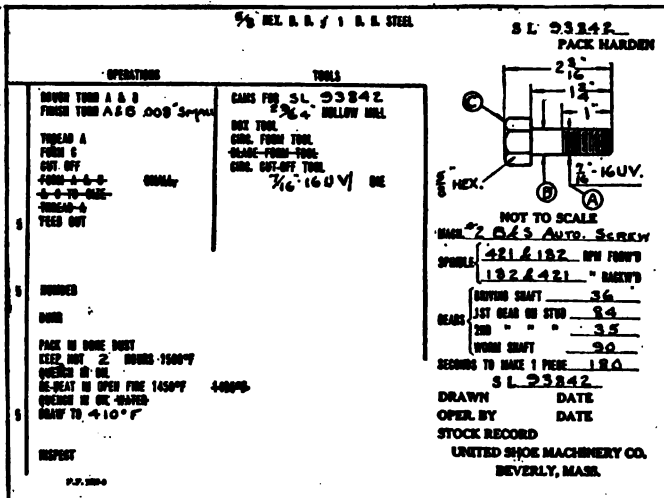

FIG. 1. SHEET FOR 1/8-IN. CAPSCREW

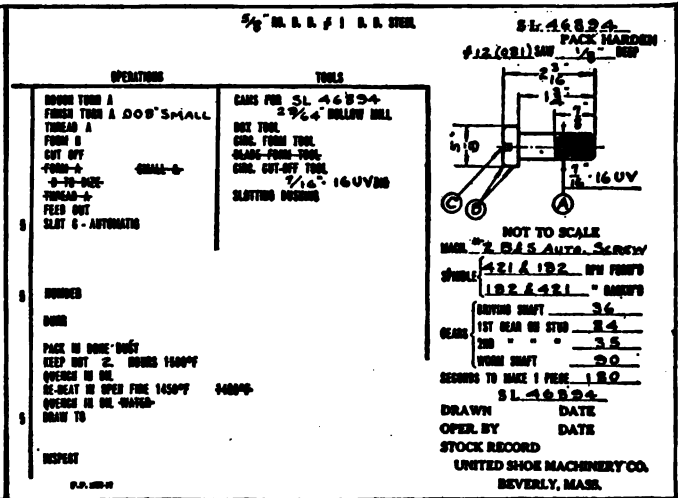

FIG. 2. SHEET FOR 1/8-IN. SCREW

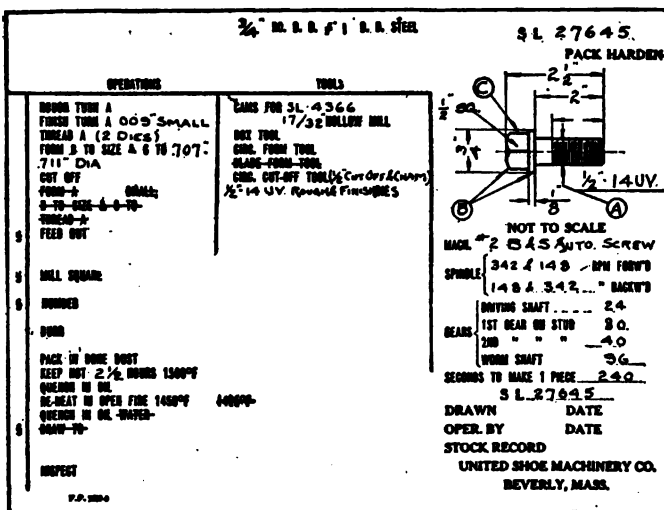

FIG. 3. SHEET FOR COLLARED CAPSCREW

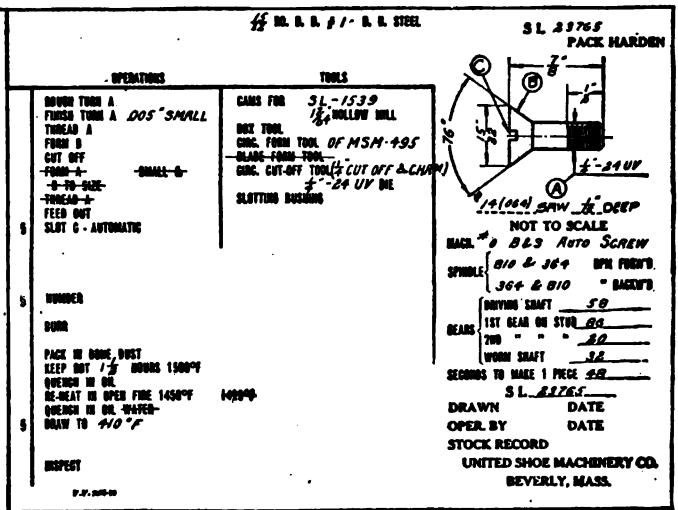

FIG. 4. SHEET FOR CONE-HEAD SCREW

used in standard machines, and for making possible the issuing of blueprint instruction sheets at a very low cost. A little study of these sheets will show their almost

and below this are instructions covering the type of machines on which the work is to be done, all necessary directions as to spindle speeds and the necessary gearing, as well as the standard time per piece.

\* Chief draftsman, United Shoe Machinery Co.

# MAKING SMALL SHOPS PROFITABLE

The left-hand column contains all the necessary operations and any special directions. Unnecessary operations are crossed out, and below this there are directions for the proper pack hardening in each case. The central column shows the necessary tools to be used.

Although only 16 examples are shown these printed sheets now cover about 30 subjects and will be added to

from time to time. They include, in *addition* to the parts shown, cam rolls, shouldered cap screws, special screws and work of this nature. It can easily be varied or enlarged to suit the individual of different shops.

This method, as will be seen, gives a very uniform set of drawings. As the draftsman is only required to add a few dimensions and perhaps cross out a few unnecessary

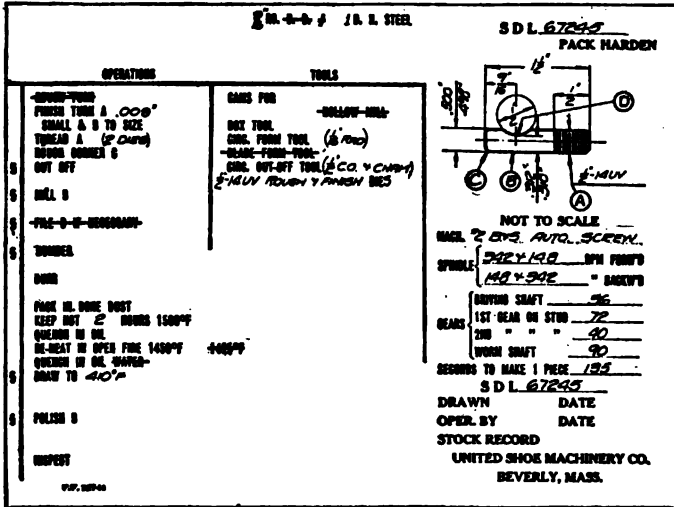

FIG. 5. SHEET FOR SPECIAL STUD

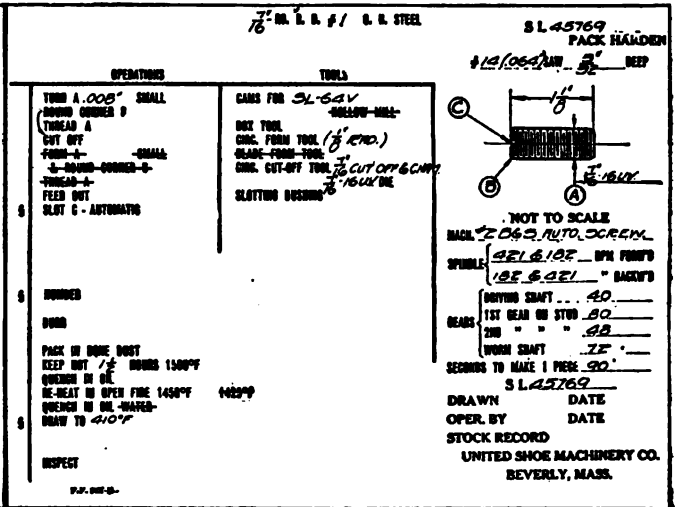

FIG. 6. SHEET FOR HEADLESS SCREW

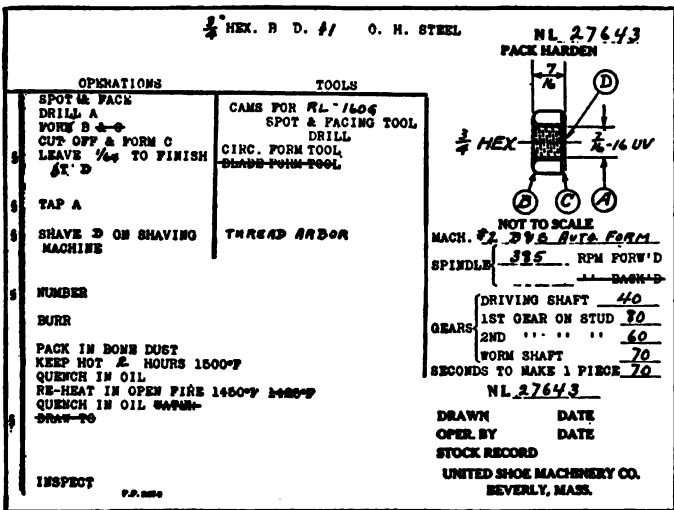

FIG. 7. SHEET FOR 3/4-IN. HEX NUT

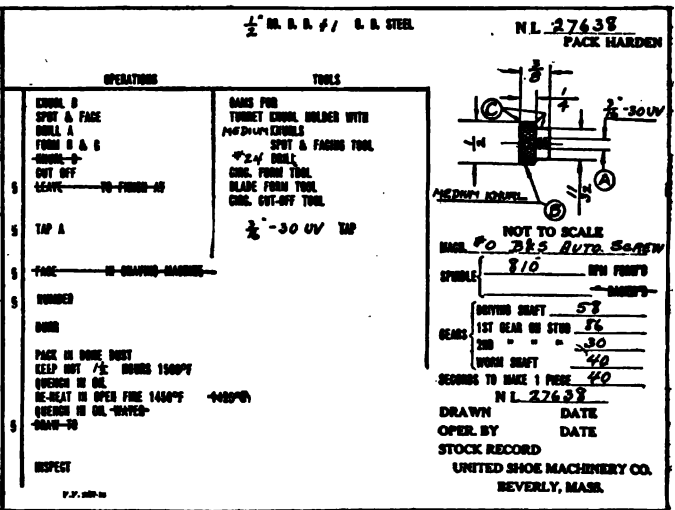

FIG. 8. SHEET FOR 1/2-IN. KNURLED NUT

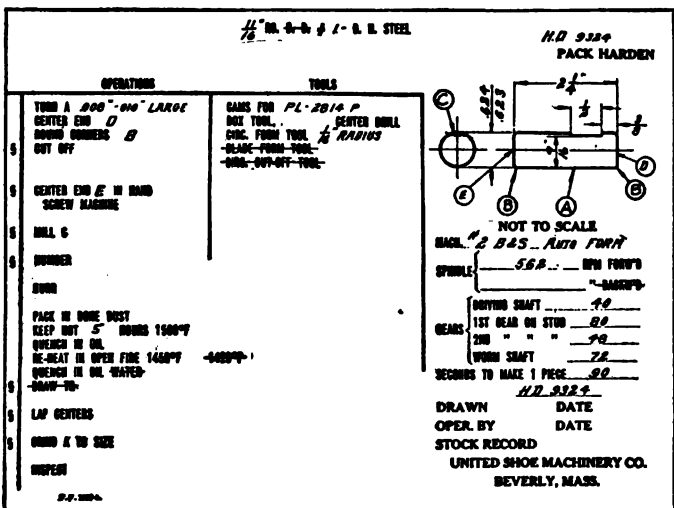

FIG. 9. SHEET FOR SPECIAL PIN

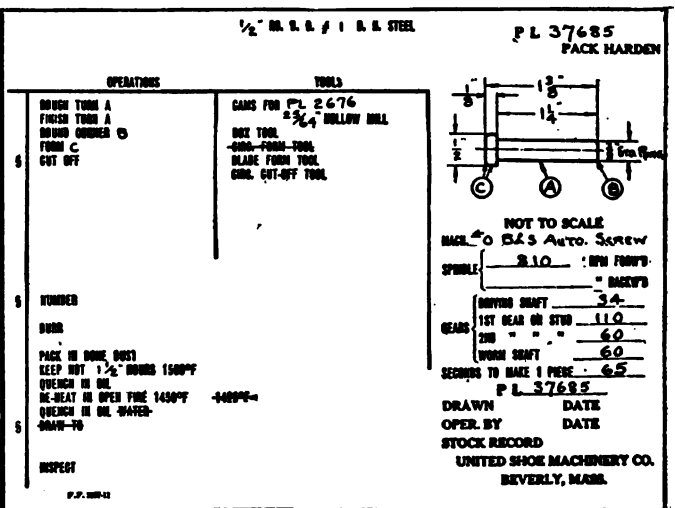

FIG. 10. SHEET FOR HEADED PIN



# Lubricating Oils and Cutting Compounds for Shop Use

BY W. ROCKWOOD CONOVER<sup>2</sup>

---

*SYNOPSIS*—Wastage of oils and cutting compounds through inexpert buying and careless use is common in machine shops. The principles that should govern selections, tests that should control quality and methods that should give satisfactory use are all outlined. The cheapest oil or compound is often the most expensive.

---

One of the subjects that enlist the attention of the manufacturer is that of lubricating oils and cutting compounds. The manufacturing plant that does not include among its departments a chemical testing laboratory where proper tests of lubricants can be made and values accurately determined often depends upon the judgment of its superintendent or department heads, with the too frequent result that either a too high price is paid for oils or else quality is sacrificed in a mistaken idea that, by employing cheap oils, money is being saved. There is scarcely any other subject connected with machine-tool operation on which there is such diversified and contradictory opinion and judgment as that of the lubrication of machine-bearing surfaces and the lubricating of cutting tools.

Often the superintendent or foreman of a department in selecting oils depends upon the judgment of the operator, which is apt to be biased by years of following some previously established rule or practice taught in the early days of learning his trade. Many of the old theories and practices have become obsolete and have been shown under the light of modern shop experience to be not only expensive, but not of equal value to the practices established in recent years.

## LUBRICATING OILS FOR MACHINERY

The preserving and maintaining of bearing surfaces of machinery and minimizing of friction are of prime importance and should have preference over all other considerations in the purchase of lubricating oils. In addition to chemical tests practical tests should be employed to determine satisfactorily the wearing quality and value of lubricants. To accept the opinion of individuals or dealers may as often prove expensive as otherwise. A reduced oil account is not economy if the ledger shows greatly multiplied upkeep and repair charges on machine tools at the end of the year and the factor of depreciation much increased. There is a wide latitude in the degree of viscosity of lubricating fluids between lubricants having a low specific gravity and lubricants having too much body; between pure mineral oils and those containing a high percentage of animal fats that tend to acidity and produce a corrosive effect, however modified, on bearing surfaces.

The small manufacturer not in a position to employ chemical analysis should at least determine by practical tests the lubricating value of given oils on the specific

work on which he desires to use them in his own factory. The importance and advantage of such tests in large establishments are equally obvious and not to be questioned, but there the conditions are essentially better and the facilities multiplied. The necessity for accurate data is also proportionately greater.

An oil purchased at a comparatively low cost may be good; it may answer the purpose, but it may be neither economical nor wise to use it in the long run. On the other hand, the axiom "The best is the cheapest" is not always a true one. Certain oils are adapted to the lubrication of shaft bearings, the bearings of shop motors and high-speed power-transmission machinery, but they are not adapted to the lubrication of the bearing surfaces of large boring mills and lathes, of millers and planers having heavy friction load. An oil of lighter body or less viscosity can be selected for the former than is practicable for the latter class of machinery. Conditions must be carefully studied—speeds, pressure, temperatures, friction load, etc.—and careful tests made, if the manufacturer would wisely and economically choose the grade or kind of lubricants adapted to his work. An error in judgment in the grade of oils for costly machine tools may necessitate repairs that neutralize the saving in purchase price for many months. With the indifferent manufacturer oil is oil, and through lack of proper attention to this important feature of factory expense the careless operative is as likely as not to use cylinder oil on all the smaller working engine parts or high-grade machine oil on line shaft bearings; and the practice is likely to be continued unobserved until serious trouble or loss results.

For the bearing surfaces of large machine tools an oil free from animal fats, of increased specific gravity and of much greater viscosity than oils designed for light high-speed machinery should be selected. This sort of lubricant will give increased wearing quality where speeds are comparatively slow and the friction loads more or less heavy. Such machine oils can be purchased at prices ranging from 14 to 20c. per gallon. With these oils there will be no increase in temperatures, and the bearing surfaces will keep in excellent condition. For babbitted surfaces on light machinery cheaper oils will serve.

Some manufacturers select an inexpensive mineral oil, costing 12c. or less per gallon, for general lubrication of machine tools, shafting, shop motors, etc. The economy of this practice is doubtful under conditions of heavy friction load or high speed, when the proper maintenance of shop machinery and of machine tools is considered and the expense of such upkeep for the year computed. An oil costing at least 30 or 40 per cent. more than the just mentioned figure will give far more satisfactory results and be found more economical in the long run, both from the standpoint of consumption and that of keeping the tools in good condition.

For lubricating the bearings of cranes of high-tonnage capacity and on some other classes of heavy machinery operated at low speed, where the friction load is not too

<sup>1</sup> Prepared for the author's forthcoming book on "Industrial Economics." Copyright, 1916, Hill Publishing Co.

<sup>2</sup> Factory economist, General Electric Co.

## LUBRICATING OILS AND CUTTING COMPOUNDS FOR SHOP USE

great to permit their use, one of the cylinder-oil stocks at a cost not exceeding 15 or 16c. per gallon can be chosen to advantage. These oils are also suitable for lubricating rubber mills, heavy rolls, cylinders, etc.

In running experimental tests and commercial tests on electrical or other machinery preparatory to shipment a good quality of mineral oil costing from 10 to 12c. per gallon should be employed as a substitute for the higher-priced oils preferred in the permanent operation of the machines. One of the reasons for this substitution is the fact that in these preliminary tests the facilities for handling the oil and preventing leakage are not, as a rule, as complete as when the machines are installed in their permanent location, and there is consequently an increased percentage of consumption and waste. It has been found by experiment that temperatures, even where machines are operated under high speed during the process of testing, are not perceptibly increased by the use of the cheaper oil. In all such cases, however, it is advisable to make careful tests on the specific work for which the lubricant is required, to determine any difference in temperature or friction load, before a permanent change is made.

### CUTTING OILS AND COMPOUNDS

Regarding the subject of cutting oils and cutting compounds there is wide diversity of opinion. Not a few manufacturers of the old school still hold the belief that pure lard oil is the cheapest and most satisfactory cutting lubricant for most classes of work in the long run. In the majority of cases this opinion is the result of clinging to old theories and of aversion to inaugurating new practices; or if based on actual tests and experiments, the tests have not been conducted on a practical basis. Were we to grant the correctness of judgment of these manufacturers in so far as the wearing quality of oil is concerned, we have still the factors of cutter grinding and the keeping of tools cool to consider. It has been demonstrated by practice that on certain classes of work and under certain conditions a compound into which water enters largely as a component part is not only cheaper in cost, but superior to pure oil in cooling properties.

On account of the number and variety of cutting lubricants on the market careful chemical analyses and practical tests should always be made by the manufacturer before purchasing. Nearly all compounds contain a certain percentage of free fatty acid and consequently are acid in their reaction, and nearly all have a more or less detergent action on metal surfaces covered with oils. Choice should be made of those compounds which are least acid and which exert the least corrosive influence on metal surfaces. This is especially important in the case of multiple-spindle machines and all machines where the work is in close proximity to the bearing heads, as under these conditions the oil is likely to become washed from the bearings and the expense of machine-tool repairs, in consequence, to be materially increased.

The initial cost of any cutting lubricant is relatively unimportant. What the consumer needs to know primarily is the action of the lubricant on the point of cutting tools in reference to absorbing and neutralizing heat generated in cutting, its lubricating properties, its wearing quality, its specific gravity, flash point, percentage of free fatty acid and in the case of water compounds its ability to form a perfect emulsion and remain in a proper

state of solution. The factor of retaining metal dust in suspension must also not be overlooked. Some compounds run dirty continually until entirely consumed, holding minute particles of metal dust in suspension until the compound becomes thoroughly charged with this foreign matter. This condition tends to increase friction at the point of the cutting tool and to raise temperatures abnormally, thereby reducing in some degree the cutting power. Lastly, the initial cost is important, but only relatively so. An oil of high market price may wear sufficiently longer than the cheaper grades to show a lower running cost per hour, and this is frequently true. It is one of the strongest arguments in favor of the use of pure lard oil or a high-grade mixture of lard and mineral oil.

When the manufacturer is about to purchase any of the cheaper oils or water compounds, he should insist upon being furnished by the refiner or dealer with running cost per hour, or consumption, on various classes of work, for comparison with the cost of lubricants he has previously been using. If these data cannot be obtained from the dealer, the manufacturer should conduct accurate and careful tests in his own shop in order to determine the relative economy of lubricants offered him. Without these precautions he can form no intelligent judgment in the matter and is as likely to be deceived as otherwise.

These comparative tests must include the cost of repairs to machine tools and many other items of information, as indicated in the paragraph on testing, in order to obtain data of sufficient value to render a decision as to purchase safe and correct. Even under such exhaustive analysis any fluctuation in the cost of maintenance of machine tools may be due to the character of the work performed and the strength of the tool itself rather than to the use of a different lubricant. For this reason it will readily be acknowledged that the manufacturer must, to some extent at least, base his decisions on broad judgment and experience, his habit of observation and his insight into the conduct of processes in his shop. It is not exceeding the limit of truth, however, to state that a very large percentage of the consumers of cutting oils and lubricants do not know with definite certainty the actual conditions with reference to economical consumption of these materials within their shops, and often too much dependence is placed on the statements of dealers or on the judgment and opinion of the tool operator.

### TESTING CUTTING LUBRICANTS

In making practical tests of cutting lubricants it is desirable to select a piece of work on which the machine can be run for at least one week, and a much longer period is preferable. The oil cups should have attention to see that there is a free flow of oil to the bearings. The tank should be thoroughly cleaned of the previous lubricant, and all bearing surfaces, turret heads and slides should be cleaned before the machine is loaded for test. It is not sufficient to allow the lubricant to flow onto the top or side of the tool. The feed pipe should be so arranged that a full, strong stream will be carried directly to the point of the tool and to the surface being cut, in order that the tools and work may be properly cooled. Of equal importance is the manner in which the tools are ground. A good compound has often been condemned through ignorance of these two essentials—the

## MAKING SMALL SHOPS PROFITABLE

adjusting of feed pipes for proper flow and the grinding of tools at the proper angle for greatest efficiency on the surfaces to be cut. Grinding the cutting tool at a wrong angle not only results in increased heating and loss of cutting power, but is frequently the cause of bad work as well. To this must be added the increased cost of frequent regrinding and the loss through delay and stoppage of productive work.

When the machine is loaded with compound and the test started, it is necessary that the proportion of stock or stock solution and water be maintained uniform throughout. Otherwise, the running cost per hour or cost for a given quantity of work cannot be satisfactorily ascertained, as the quality of the work will not be uniformly good. With all cutting lubricants into which water enters as one of the component parts the factor of evaporation is a serious one, and it is necessary, after the first day's run, to add more water, in greater or lesser amount, each succeeding day to hold the proportions constant. The degree of dilution called for in the manufacturer's or dealer's specifications should be maintained throughout the test. Without this care the operator will after a few days be running a mixture fully as expensive per hour's run or per piece as lard or other oils. It may be even more expensive.

In conducting comparative tests the following data should be carefully kept: Total running time, time spent grinding tools, time spent on repairs or other delays, actual operating time, condition of tools at commencement, depreciation of tools, speed and feed, number of pieces finished, quality or character of work done, number of gallons of compound in reservoir at start, number of gallons of compound in reservoir at finish.

With preliminary tests of this kind the cost per running hour and ratio of economy and advantage between different kinds of cutting compounds sold on the market, or between a cutting compound and a cutting oil, may be safely and satisfactorily determined. In the case of lard oil or mineral oil or a mixture of both the oil should be reclaimed from the chips and this amount deducted from the quantity with which the machine was originally loaded, the cost of reclaiming being considered in the final estimate.

After the choice of a cutting compound has been determined upon, the bearings of the machines should be opened at reasonable intervals and conditions noted; and careful inspection should be made of slides and all other wearing surfaces with which the lubricant has come in contact. Machines operated with any of the various water cutting compounds should be inspected and cleaned with greater frequency than those loaded with oil for reasons previously indicated in the paragraph relating to fatty acids and their tendency to corrode or wash oil from bearing surfaces. The cost of machine repairs should also receive attention and a comparison be made, after a reasonable length of time, with previous periods, taking into consideration the number of hours the tools are operated and the character of the work or burden placed upon the machine.

In addition to the reduced cost per running hour effected by the use of proper cutting compounds the factor of speed is worthy of consideration. It has been demonstrated that, with the right kind of lubricant, the cutting speed can in many instances be increased from 10 to 15 per cent. As productive output per machine is of

prime importance, particularly in the factory where tool equipment and space are limited, the securing of this advantage is desirable.

There are certain classes of work in the shop, such as milling large-sized keyseats, turning, tapping, threading and milling operations on steel containing a high percentage of carbon, where the work involved is unusually hard, in which the use of pure lard oil is wise. In this case it is well to use either a grade known as "prime lard oil" or one known as "off-prime lard oil." The amount of fatty acid in the former does not usually exceed 2 per cent., and in the latter the percentage is only slightly greater. The advantage of employing these grades, where pure lard oil is indicated, will be apparent, as they exert little or no detergent effect on machine tools, greater speeds are possible than can be secured with cheaper grades of oil, and they give most excellent service from any standpoint. The lower grades, known as "extra No. 1 lard oil" and "No. 1 lard oil," are not recommended. The former may contain as high as 10 per cent. of fatty acid, and in the latter this element may reach 20 per cent., which makes it undesirable as a cutting fluid.

### LARD OIL AND LARD-OIL MIXTURES

A large percentage of the heavy-duty work in most shops can be done to advantage with mixtures of lard oil and mineral oil or a good quality of mineral oil.

For automatics and for general screw-machine work on copper and steel where tapping or threading constitutes a part of the operations performed a lubricant consisting of equal parts of lard oil and mineral oil undoubtedly gives the best service. The mineral oil should be of fair quality, and the cost of the mixture should not exceed 35 to 40c. per gallon, according to market prices on lard oil. This makes a good lubricant of excellent body and sufficiently viscous to form a continuous and comparatively thick film on the point of the cutting tool. The tools stand up well and require less grinding than is the case when lighter-bodied oils are employed.

This formula for cutting oil, designed to do the most difficult operations of tapping and threading copper and steel in automatics and turret machines and other heavy-duty work on steel, is more satisfactory and more economical in consumption than the so-called mineral lard oils and screw-cutting oils generally offered to the manufacturer. The mineral lard oils and screw-cutting oils at prices ranging from 24 to 35c. per gallon must necessarily contain an increased amount of mineral oils or low-grade petroleum distillates, in order to yield the oil manufacturer or dealer a profit. If the consumer mixes his own lubricant, he is enabled to obtain a full-strength, equal-part solution of the two oils at a figure as low as, or lower than, he is compelled to pay for the so-called special cutting oils on the market. And this equal-part mixture has greater wearing durability and keeps the tools in better condition.

Any statements made to the effect that the mineralized lard oils or screw-cutting oils can be employed as a lubricant base and thinned down in the same manner in which prime lard oil or off-prime lard oil is capable of being reduced should receive careful and serious consideration before purchases are made.

From an economical standpoint the consumer will find it wise to make his own mixtures. By doing this he has accurate knowledge of the quality of the lubricants employed

## LUBRICATING OILS AND CUTTING COMPOUNDS FOR SHOP USE

on his machine tools, the ingredients composing each formula are fully within his control, the machine-tool equipment is better conserved, and a saving of at least 25 per cent. in initial cost should be the result.

In general, for the purposes of drilling, turning, shaping and cutting off of steel and copper and also for all operations on brass in automatics, semiautomatics and multiple-spindle turret machines a good quality of mineral oil not exceeding 12 to 15c. per gallon in cost gives excellent service. If this oil has a proper degree of viscosity, it will spread a continuous film on the point or face of the cutting tool, reducing friction and preventing abnormal heating and wear. The oil should flow freely through the pump and supply tubes. It is not necessary to employ the higher-priced mineral oils, screw-cutting oils or mixed lard oils for this class of work. This grade of oil is also suited to many operations on the lathe, miller, keyseater, etc., where an oil lubricant of comparatively light body is indicated. It not only keeps the tools cool, but wears well on the usual classes of work performed on the latter type of machines.

For steel sheet punching and for some classes of drawing work where the materials are not too heavy this grade of oil makes a satisfactory lubricant. It will be found, in competition with water lubricants, on steel sheet to show a lower cost per running hour or per machine. It also keeps the dies in better condition, reducing the amount of grinding. For the heavier work of drawing cups or shells from heavy steel sheets an oil of greater body is necessary. This may be prepared by mixing lard oil and mineral oil in proper proportions.

### DETERGENT EFFECT OF WATER COMPOUNDS

The advocates of water compounds will dispute the wisdom of employing oil for drawing work, but it is always better to use oil, except on lighter drawing processes, unless a reduced cost per operating hour or a reduction in total consumption cost can be shown to be accomplished by the former. The claims of great savings effected by the water compounds are frequently not borne out in actual practice. They also exert a detergent effect on machine tools in many cases, while oil maintains the dies and presses in good condition. The factor of evaporation in compounds into which water enters largely as an ingredient is also so great as often to render their adoption uneconomical and often prohibitive.

A large number of manufacturers still cling to the practice of using screw-cutting oils or mineralized lard oils on the greater percentage of their work. This practice in many cases is neither warranted nor indicated by the conditions. A very large percentage of the work in most factories, with the exception of tapping and threading operations on steel and copper, can be done with a good quality of mineral oil with far greater economy. This oil can be purchased at prices not exceeding 12 to 15c. per gallon.

Some manufacturers prefer a mixture of lard oil and fuel oil or of lard oil and kerosene in various proportions for cutting lubricants. These mixtures are used in bolt-threading and nut-tapping machines and also in automatic and hand screw machines. While the initial cost per gallon is below that of lard oil and mineral oil in equal proportions, fuel oil or kerosene is not recommended because of the low flash point of these oils. It is doubtful, also, if these formulas give the same degree

of durability as the equal-part mixture of lard oil and mineral oil.

The subject of cutting lubricants into which water enters largely as a component part of the formula deserves careful consideration. The number of these compounds offered on the market in recent years has greatly increased. The manufacturer is pressed to make a trial of each new brand, with the assurance that it is far superior to anything previously put forth, both in the quality of the mixture itself and in the reduction of consumption cost made possible by its use. The arguments of the salesman are frequently clinched with the statement that the new compound is the result of years of study on the part of some scientist whose discovery the dealer has been fortunate enough to secure and is now ready to sell the manufacturer at prices that will revolutionize the expense of tool lubrication.

### CONFUSION IN LUBRICANT PRACTICE

The progressive manufacturer desires to adopt all reasonable measures to keep in the front ranks of those aiming toward efficient management in business, with the result that he tries out many of these so-called new compounds, hoping thereby to save large sums of money, as he has been definitely assured he can do. All this experimenting tends to confusion in the lubricant practice in his shops and may in the end work injury to his machine-tool equipment, unless these tests are confined to a very limited number of machines in one department and are conducted for a long period of time before the use of the material is extended.

A large percentage of the cutting lubricants prepared with water have a detergent effect on metal surfaces. tend to wash the oil from the bearings and slides and to gum the working parts of machine tools. Many dealers claim that their compounds do not have a corrosive effect on metal surfaces and that the soluble oils, of which the better grades of these compounds are composed, lubricate and preserve the bearings and slides of the machines. That the oil portion of these compounds counteracts to a considerable extent the chemical action of the water is conceded.

In general, lubricants having water as a component part are not recommended for automatics, hand screw machines or any class of machines of the turret type where there are numerous working parts—exposed or otherwise—with which it will come in contact. The factor of evaporation is so great in the case of water solutions and the wearing quality or durability of these solutions so much below that of good oils as to render the economy effected a somewhat negligible quantity, when the maintenance of machine-tool equipment in prime condition is considered. And this is a most important item of expense in the large factory, bearing a direct relation to the investment in new tools. It is also true that in many instances carefully conducted tests will indicate the running cost per hour, or for a definite period, of a water compound to be in excess of that of a mixed lard oil, properly proportioned, or of a good grade of mineral oil, while the arguments in favor of the employment of oils on the previously mentioned types of machines are enhanced by the fact that with the use of oils the danger of corrosion is entirely eliminated.

Water compounds may be employed to advantage on certain classes of work and on certain kinds of machine

## MAKING SMALL SHOPS PROFITABLE

tools where the working parts are few and the danger from the action of water is reduced to a minimum. On plain horizontal lathes and on lathes of the Gisholt type, machining steel, etc., and on millers and drilling machines operating on both iron and steel the use of these compounds is indicated. They give excellent service, also, on coldsaw work.

In using water compounds on gear-cutting machines special care should be exercised in selecting a mixture that will not in any degree, however slight, gum or clog, as otherwise the index feed may be thrown out of true.

For the lighter machine operations, including plain drilling and milling processes, a simple, standard soap compound of good quality may be employed to advantage. For vertical drilling machines of the automatic-feed type these soap compounds are adapted to quite a wide range of work on steel and iron. They are sufficiently viscous to afford a fair amount of lubrication to the point of the tool, and at the same time the tendency to heating is largely overcome by the large percentage of water.

On account of the composition of soap bases and rapid evaporation of water these compounds require more or less frequent addition of water or of the stock solution, in order to maintain a proper degree of specific gravity throughout the run. The initial cost is attractive to the consumer, and this should not exceed from  $\frac{1}{2}$  to 1c. per gallon for the solution when prepared ready to load into the machine.

### A GOOD COMPOUND FOR MANY OPERATIONS

A good compound for the heavier classes of work, such as milling steel, cutting off steel on coldsaws and turning, boring and facing of steel castings on lathes and boring mills, may be prepared by the manufacturer within his own plant by combining a good-quality soap base with pure lard oil, soda and water in proper proportions. The proportion of lard oil entering into the formula should be graded from 1 to 5 gal. per barrel of solution, according to the class of work to be done. These mixtures will range in cost from 2 to 8c. per gallon.

This formula gives good service on a variety of operations on metals where the employment of a water compound of heavy body is indicated. It forms a strong, viscous solution that flows freely, supplying abundant lubrication to the point of the cutting tool and at the same time reducing the temperature to a minimum. The life or wearing qualities are excellent, due to the percentage of pure lard oil entering into its composition. It will be found to meet the severest conditions under which a water compound may be expected to work to advantage, while the initial cost of the several proportions or degrees of strength of the formula is lower in most instances than the various dilutions of the so-called soluble oils on the market. In general, the weakest form of the solution, costing approximately but 2c. per gallon, will do the work of mixtures costing from 30 to 50 per cent. more.

A good compound for grinding cams and cones and finishing shafts may be made by combining lard oil and mineral oil with a soap base, soda ash and water in proper proportions. The cost of this mixture should not exceed  $\frac{1}{2}$ c. per gallon ready to load into the machine. Notwithstanding this low initial cost, it proves a most satisfactory lubricant for this class of work. The tendency to hold metal dust in suspension is minimized to a

degree that renders it specially *adaptable* to automatic grinders for various classes of finishing operations. The quality of work obtained is equal to that secured by any of the more costly preparations.

### APPLYING SOLUBLE LUBRICANTS TO TOOLS

It is of the utmost importance in operating machines with soluble cutting lubricants that a strong, full stream of the fluid be supplied to the tool. The success or failure of a lubricant often depends upon this factor as much as on any other. It is sometimes desirable to supply the lubricant to the tool from different angles with more than one feed pipe, in order to flush the cutting point or edge to the fullest degree possible and also to lubricate the work.

The method of application has more to do with results than most overseers or tool operators appreciate. In shops where a number of machine tools are grouped or arranged in series a system of overhead tank and piping, conducting the lubricant to each individual tool of the group, affords an efficient method of lubrication. Sufficient compound to operate all the machines for a given length of time can be prepared and loaded into the supply tank, thus simplifying the labor of handling. By the introduction of proper methods of supplying the lubricant, speeds can often be increased and additional cutting tools employed.

As previously stated, the factor of evaporation in all cutting lubricants containing water is important. As it is necessary to add a small percentage of water daily to the tank, after the machine has been started, a careful inspection should be made at intervals to keep the dilution in proper proportion. Unless this is done, the cost of operating may equal or exceed that of clear oil, and no economy result. Since the degree of evaporation varies according to atmospheric conditions, it is not sufficient to add an equal quantity of water on each succeeding day.

Metal dust and other foreign matter with which compounds come in contact in the pan or tank of the machine also affect the specific gravity to a considerable extent. It is desirable, therefore, to use those compounds in which the tendency to hold metal dust in suspension is modified to as great a degree as possible. Where stock solutions of compounds are prepared and stored for future use, the barrels should be tightly headed to prevent evaporation and the solution drawn off through faucets in preference to opening the barrel.

The number of lubricating oils and cutting compounds required in any plant, however large, is generally comparatively limited, and the more simplified the practice the more economical and satisfactory are the results obtained.

### CARE AND DISTRIBUTION OF OILS AND COMPOUNDS

All stocks of oils and cutting compounds should be kept in a central storehouse under the supervision of a competent person to whom orders can be sent by the various foremen for such supplies as are needed for their current use. All solutions or compounds should be prepared at the oil house and delivered to the departments on signed orders only. It is not good practice to allow the foreman or boss of a department to make up mixtures according to his own judgment of what may be required for his work. This procedure tends to confusion and



## LUBRICATING OILS AND CUTTING COMPOUNDS FOR SHOP USE

prevents establishing and maintaining a uniform practice throughout the factory on similar processes. There is a common tendency among shop foremen to make up mixtures of their own for special jobs or to use a different oil from their neighbors on similar classes of operations and metals. There is not only no economy effected under this method, but on the contrary there is certain to be conspicuous loss. The manufacturer will be constantly called upon to purchase, either for trial or permanent use, some oil or compound not already in stock, to suit the whim or fancy of the individual overseer or workman.

A printed schedule of practice should be placed in the hands of the section superintendents or head foremen of each department, showing the various kinds of lubricants to be used for all classes of work throughout the factory. The oilhouse keeper should be provided with a record giving the formulas he is to prepare and keep in stock. He should also be provided with schedules showing the kinds of oils or compounds to be used in the several departments, together with the names of foremen eligible to draw these materials. An additional list including the names of foremen eligible to draw pure lard oil should also be in his possession.

### STANDARDIZING LUBRICANT PRACTICE

With these data he is enabled carefully to scrutinize all orders received and question the filling of any orders calling for lubricants which the foreman is not scheduled to use. By following this system the manufacturer will find that he is enabled to secure absolute uniformity of practice in his shops, and in addition to this he is enabled to control consumption within the limits of production requirements and prevent undue waste.

A good supply of small cans and spouts should always be kept in stock, so that no leaky cans may remain in the hands of the workmen.

Analyses and tests should be made at intervals on all oils purchased, in order to insure against adulterations and also to keep the standard of quality up to the specification as provided for in the original contract made with the oil refiners or dealers.

A record should be made of all oils and compounds delivered to the various departments. Regular monthly reports should be issued to the superintendents of sections and also to the head foremen of departments, in order to keep them advised of the rate of consumption and enable them to control the supplies of lubricants used within the portions of the factory under their jurisdiction. These reports are also criticized by the general superintendent or factory economist and the attention of the department heads called to any excess.

## Preventing Local Shrinkage in Aluminum Castings

By F. WEBSTER

In making aluminum pattern plates difficulty was experienced from surface cavities opposite each deep part, as shown in Fig. 1. It had been customary to mold these plates with the deep parts in the drag, using a riser over each thick place.

A method of molding them in the cope is now practiced with great satisfaction. The same pattern serves as before,

but reversed; and wire vents are made in the sand over each piece. Also, there is used on the plate a riser having a form of a pyramid instead of a cylinder, so as to prevent

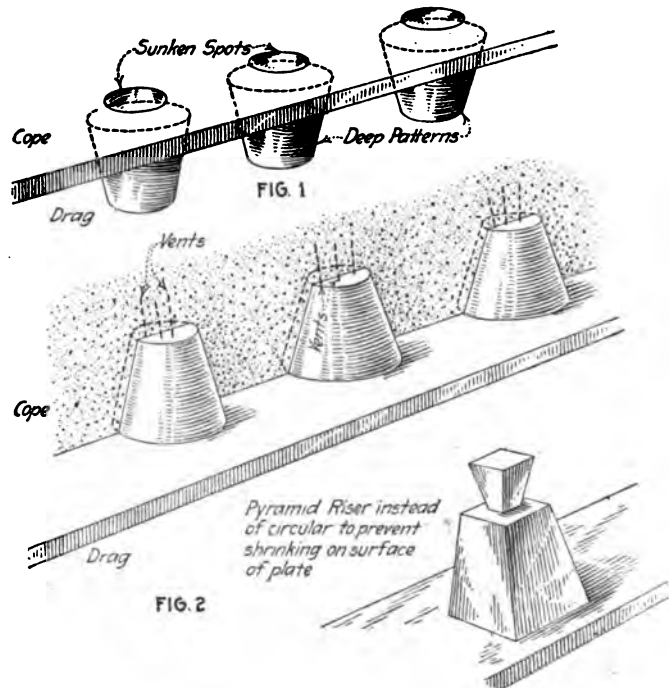

### PREVENTING SURFACE SHRINKAGE ON HEAVY PARTS OF ALUMINUM CASTINGS

a sunken ring around the riser. Fig. 2 shows the arrangement.

[Surface shrinkage on heavy parts is caused by their cooling more slowly than the light parts. It can be cured in many cases by the insertion of metal chills in the mold surfaces of the heavy parts. These equalize the cooling and prevent surface shrinkage.—Editor.]

## Adjustable Driver

By A. E. HOLADAY

The accompanying sketch shows a dog driver for a universal milling machine. All dog drivers for milling machines have two screws *A*, one on each opposite end. In making special small tools it is desirable a great

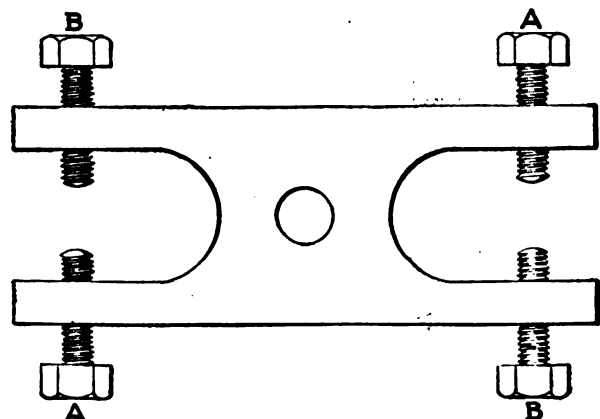

ADJUSTABLE DRIVER

many times to move the tail of the dog a few thousandths of an inch in milling flutes or for clearance. By placing two additional screws *B* on the driver it is possible to get very close adjustments, and I have found it has saved my departments a great amount of time.

# From A Small-Shop Notebook

By JOHN H. VAN DEVENTER

SHAFT-STRAIGHTENING PRESS  
MADE WITH I-BEAM

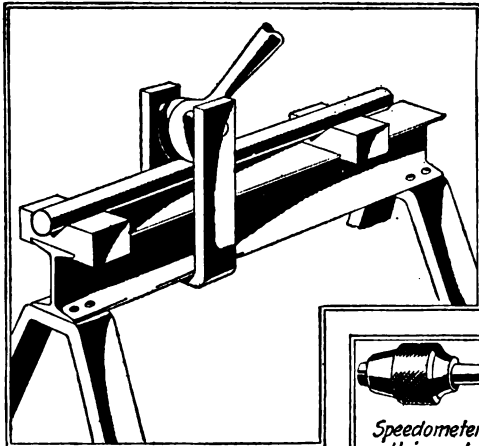

REMOVING BROKEN TAP EASILY  
WITH TWO PUNCHES

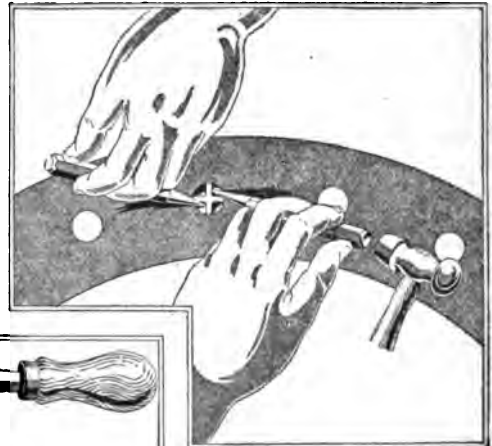

CLOSE-QUARTER  
DRILL  
MADE IN  
AUTO REPAIR  
SHOP

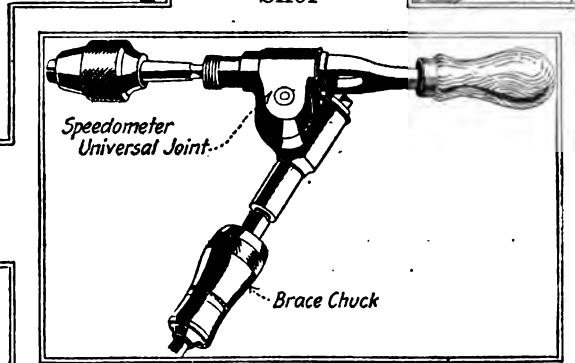

EASILY MADE PUNCH  
FOR THIN SHEETS

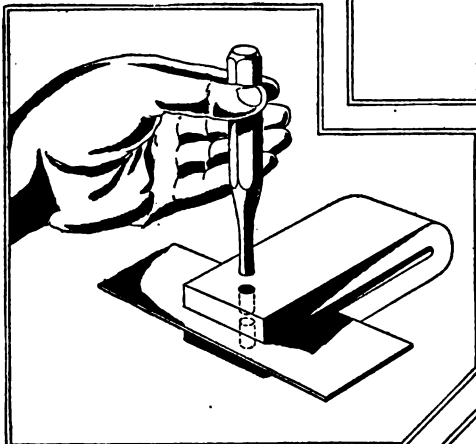

BELT LACE, SPLIT IN  
THE BENCH VISE

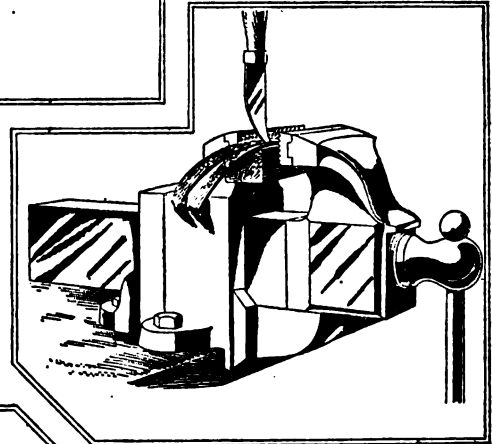

SWIVEL  
FILING TABLE  
FOR STRAIGHT  
SURFACING

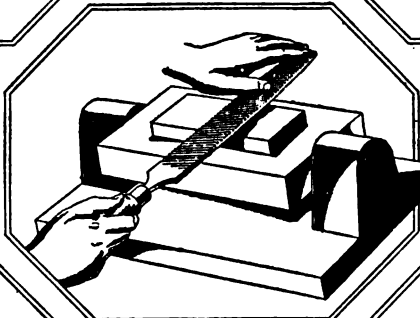

AN EASY WAY TO LIFT  
A PLANER CHUCK

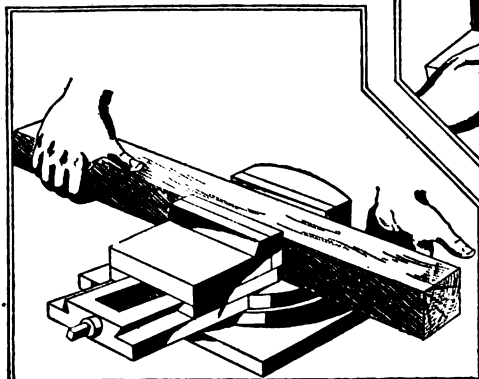

TAPER V-BLOCKS FOR  
CROSS DRILLING

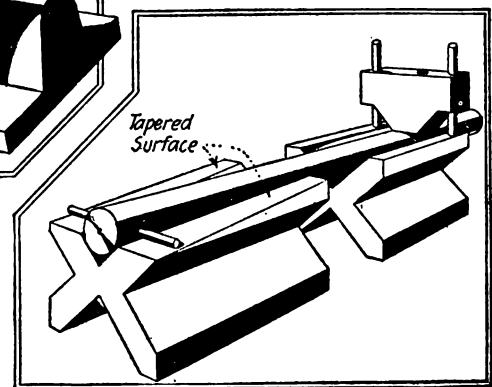

## Bench, Vise and Assembling Methods

THREADING THE END OF A LONG SHAFT ON TWO LATHES

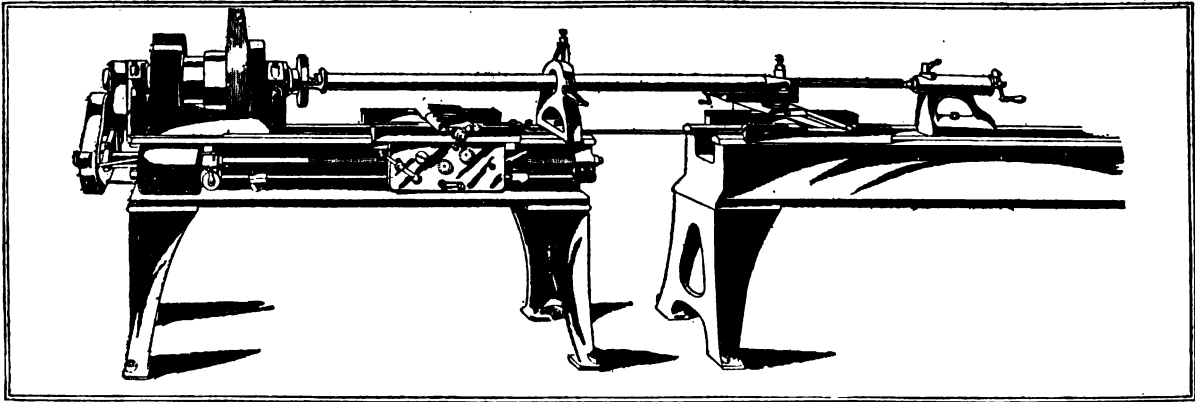

SIMPLE THREAD  
CLEANER

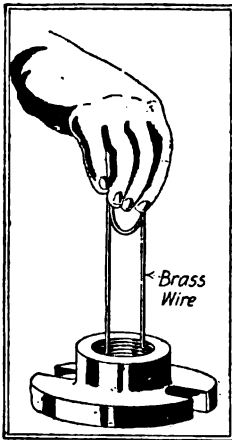

SHEARING SMALL PINS  
IN THE LATHE

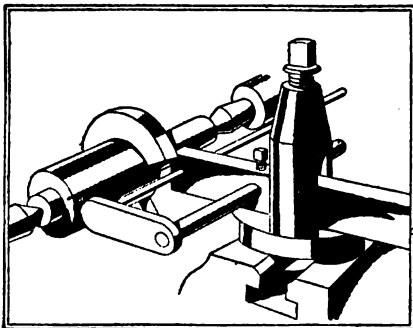

ARRANGING A LATHE  
FOR MILLING

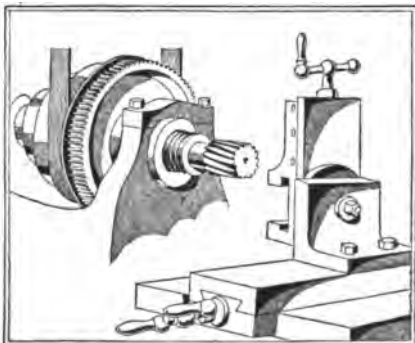

THIS ENGINE LATHE IS TACKLING  
A BORING MILL JOB

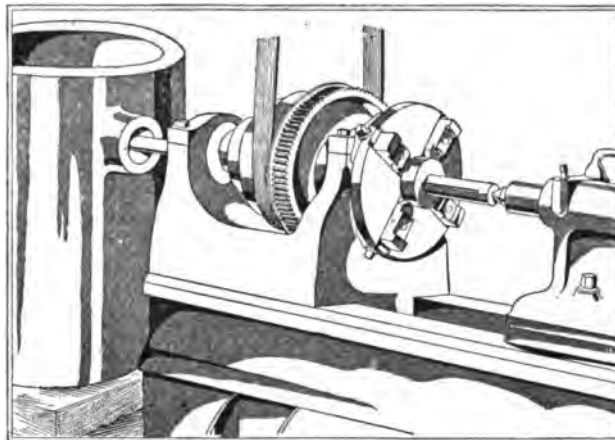

CENTER-BEARING  
SWAB



CENTER-OILING  
DEVICE

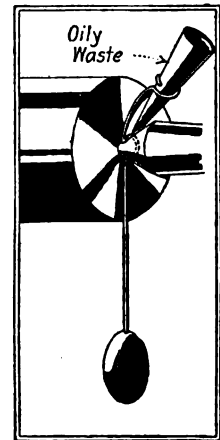

SIMPLE BUT EFFECTIVE  
FOLLOW REST

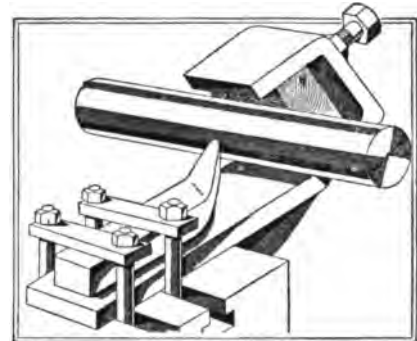

RIGID BORING WITH  
PILOTED BAR

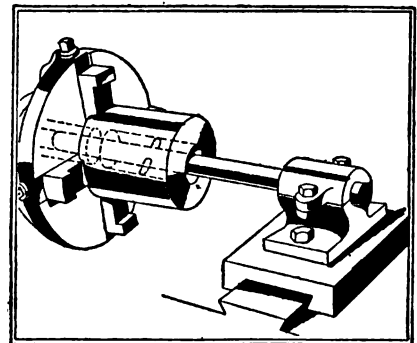

Devices That Make Lathes Profitable

# From A Small-Shop Notebook

BY JOHN H. VAN DEVENTER

## THREE DEVICES THAT SQUARE UP A HAND TAP

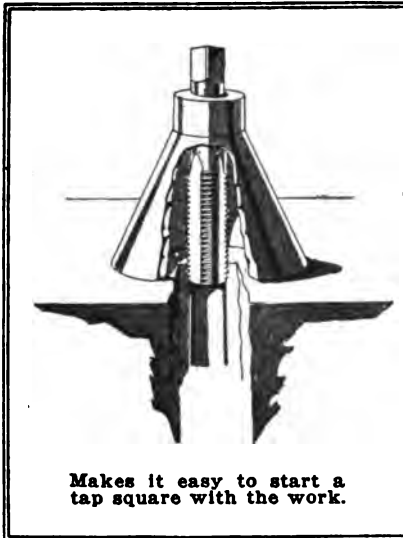

Makes it easy to start a tap square with the work.

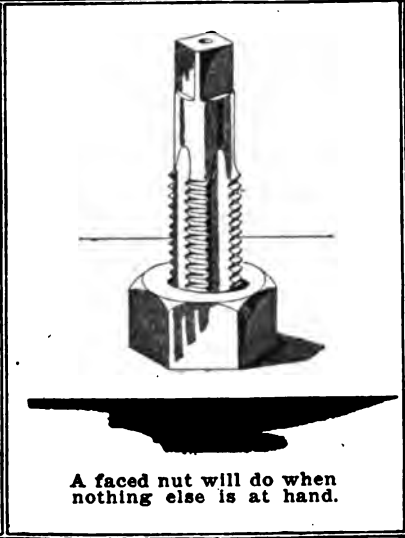
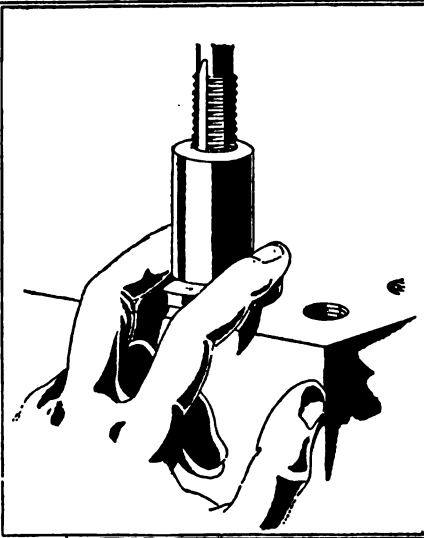

A faced nut will do when nothing else is at hand.

## EASY LOCAL ANNEALING OF SAW BLADES

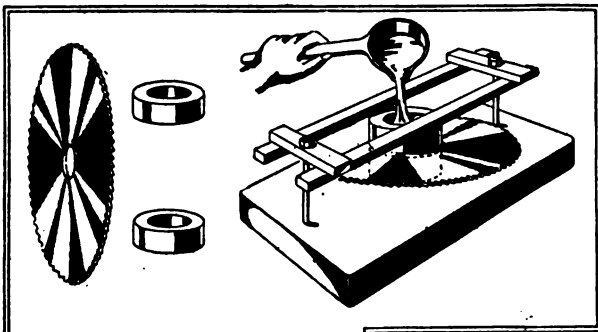

Melted lead does the job so one can file a keyway

## SIMPLE HAND FIXTURE FOR WIRE RINGS

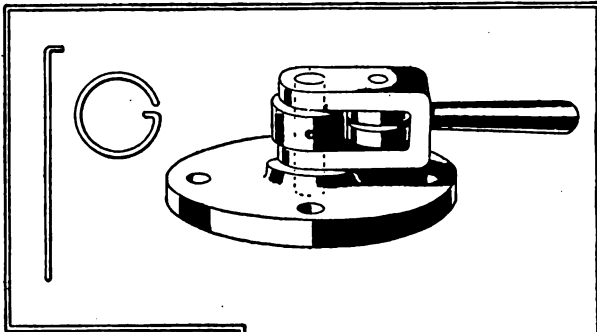

This device will take up little room and pays rent.

## MAKING AN ACCURATE TEMPLET

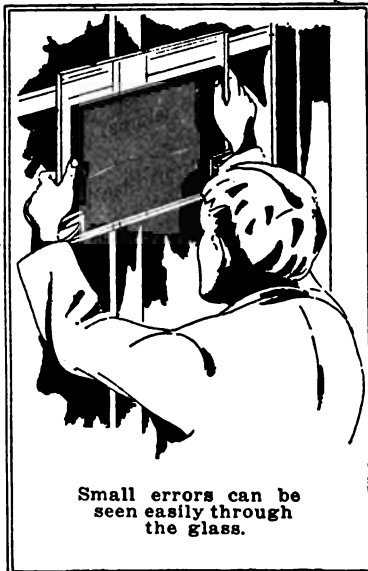

Small errors can be seen easily through the glass.

## A PIPE WRENCH FOR EMERGENCIES

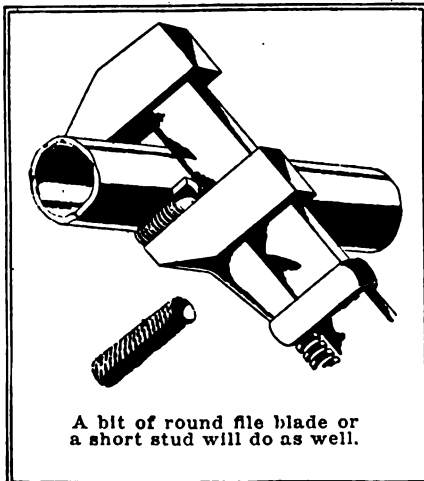

A bit of round file blade or a short stud will do as well.

## OIL GROOVING WITH TWIST DRILL

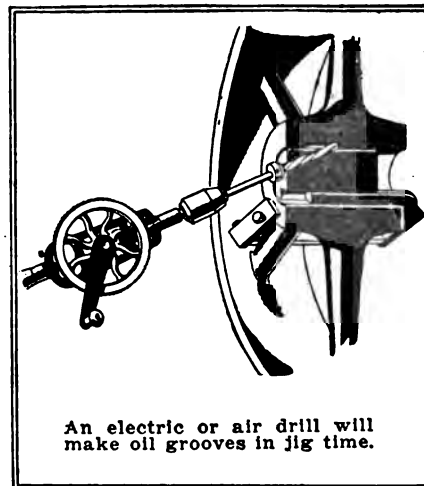

An electric or air drill will make oil grooves in jig time.

## BENCH, VISE AND ASSEMBLING METHODS

TURNING A CONCAVE SURFACE

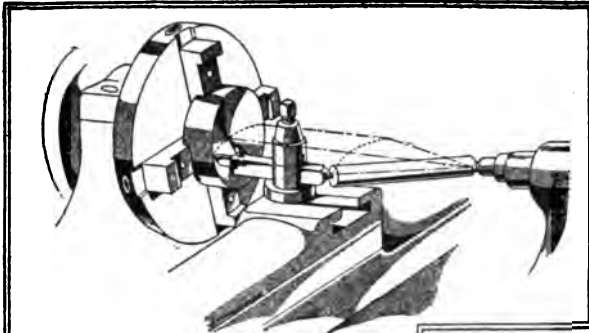

A mandrel with large centers is all of the rigging needed.

A THIN TUBE TAPPING KINK

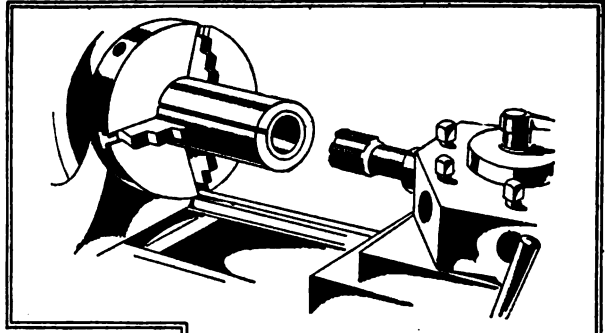

Thin tubes chucked like this will tap without distortion.

A FOLLOW REST FOR SMOOTH STOCK

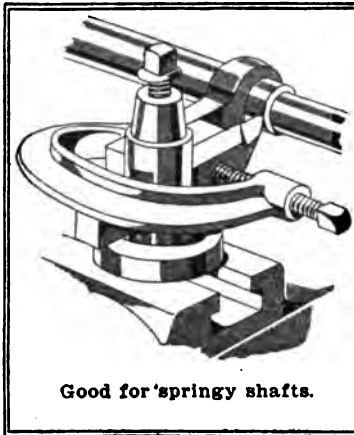

Good for 'springy shafts.

MULTIPLE FACING TOOLS IN LATHE

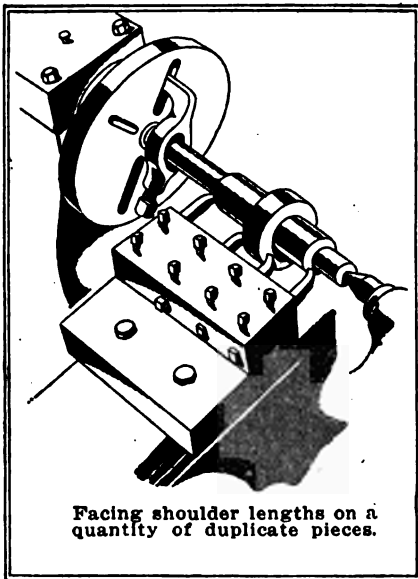

Facing shoulder lengths on a quantity of duplicate pieces.

SIMPLE BALL-TURNING FIXTURE

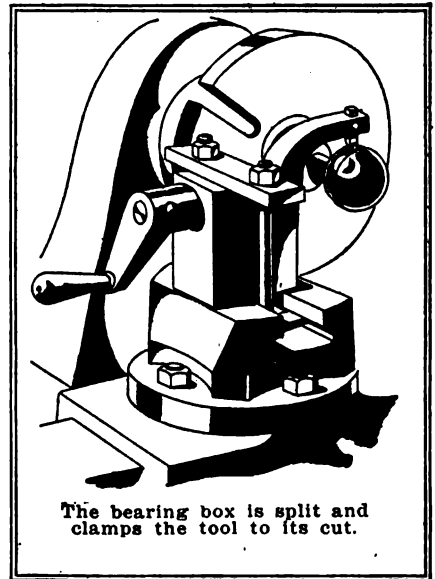

The bearing box is split and clamps the tool to its cut.

SELF-LUBRICATING TAIL CENTER

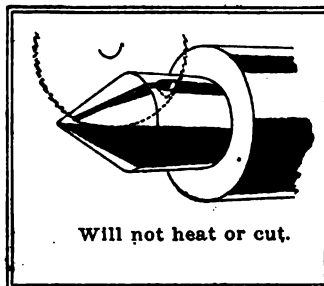

Will not heat or cut.

RIGGING UP A TAPER ATTACHMENT

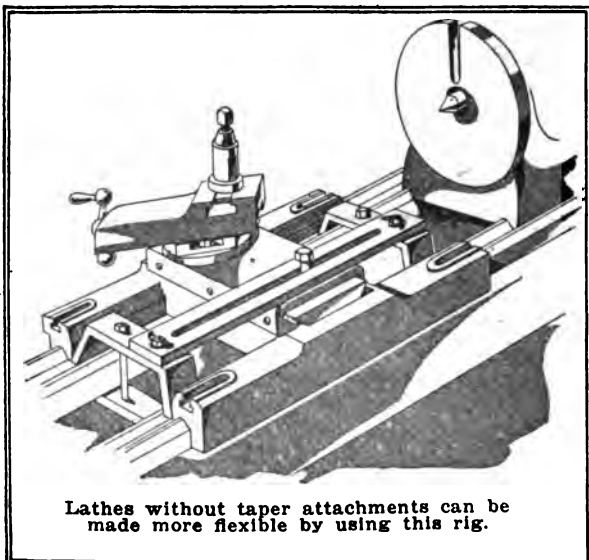

Lathes without taper attachments can be made more flexible by using this rig.

FORM TURNING IN THE ENGINE LATHE

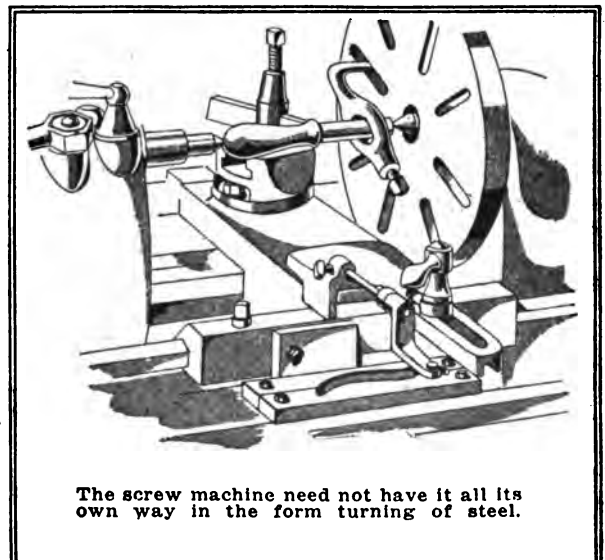

The screw machine need not have it all its own way in the form turning of steel.

DEVICES THAT MAKE LATHES PROFITABLE

# From a Small-Shop Notebook

By JOHN H. VAN DEVENTER

PROFILE BORING WITH  
TAILSTOCK TEMPLET

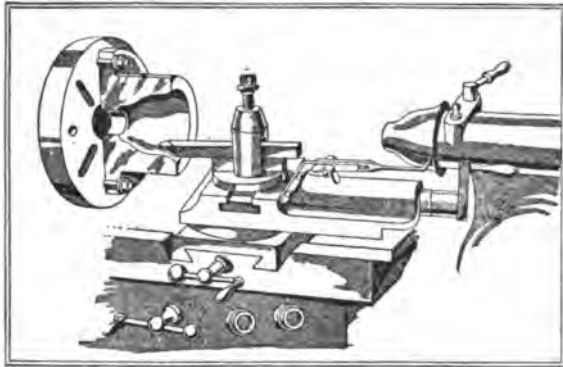

A SPECIAL TOOL POST  
FOR CRANK PINS

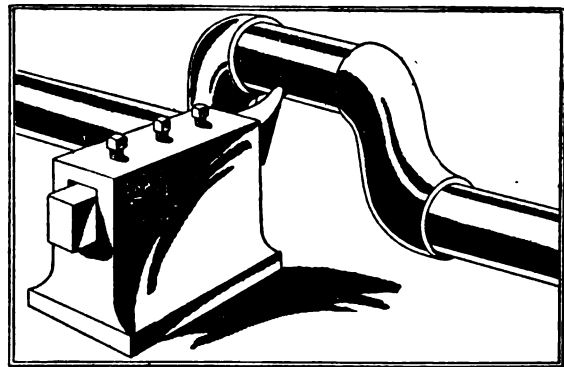

A SCREW-MACHINE JOB  
IN THE LATHE

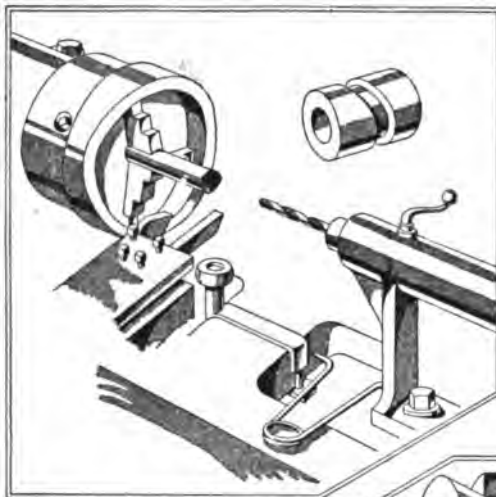

SIMPLE  
CENTERING  
"MACHINE"

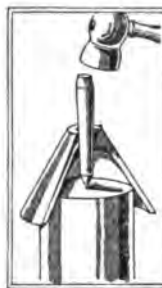

ADJUSTABLE  
ARBOR  
FOR HEAVY  
WORK

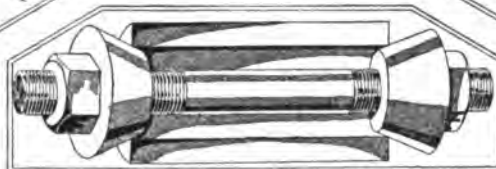

USING A PIPE TAP  
AS A CHASER

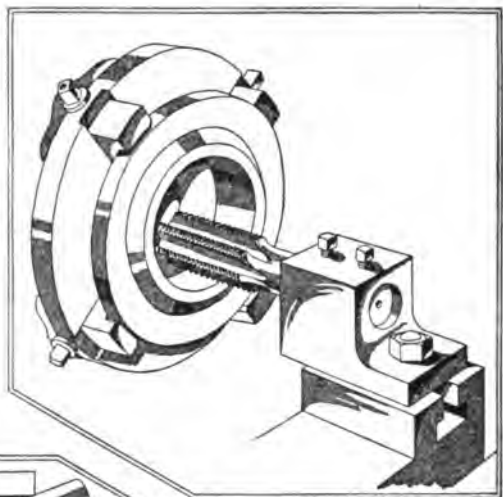

TURNING A CURVE  
WITHOUT TEMPLET

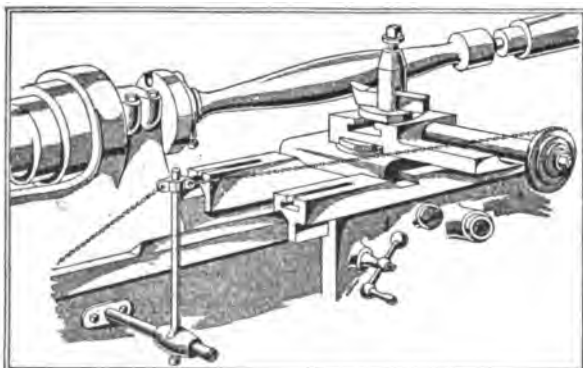

ONE WAY TO MAKE  
A HEAVY SPRING

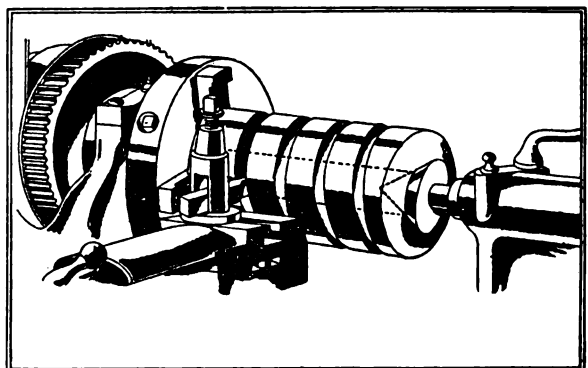

DEVICES THAT MAKE LATHES PROFITABLE

DIE FOR DRAWING  
LIGHT TUBING

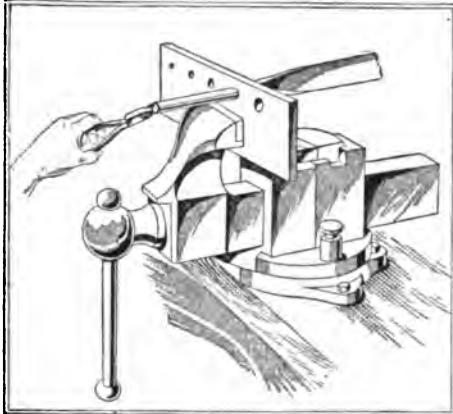

FORM MILLING  
TO TEMPLET

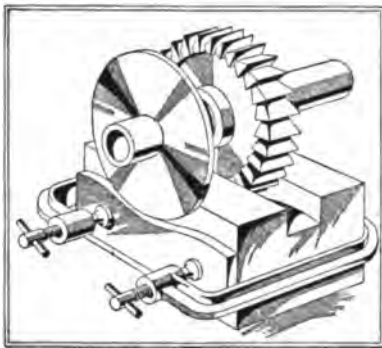

BENT TIN FOR TAP  
ENLARGING

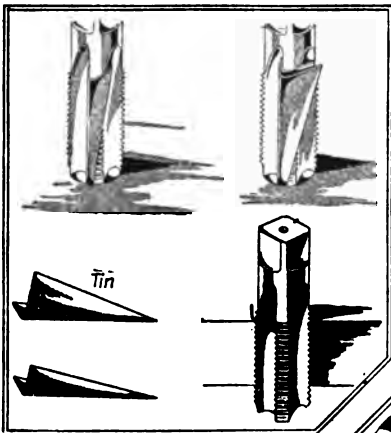

COTTON WASTE IS  
ALSO USED

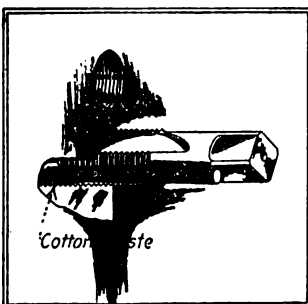

TUMBLING  
"BARREL"



GRADUATED PUNCH-BAR  
FOR SPACING

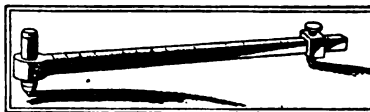

TURRET WORK ON  
BORING MACHINE

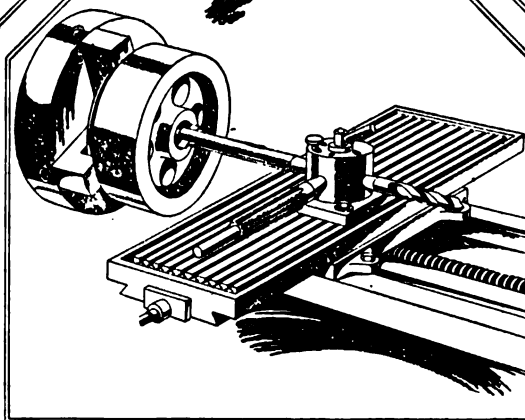
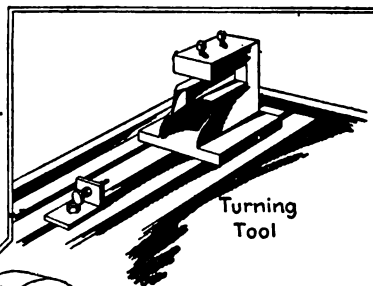

THIS GIVES REDUCED  
SIZE OF TAP

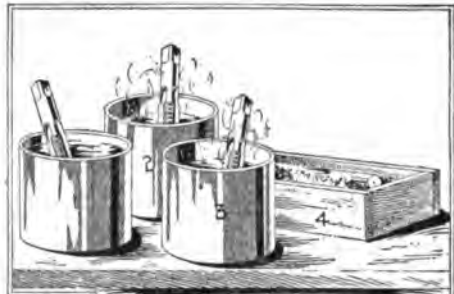

- 1-Muriatic Acid, 1 Part
- 2-Nitric Acid, 8 Parts
- 3-Hot-Soda Solution
- 4-Sawdust

SAVES TIME ON  
BUSHINGS

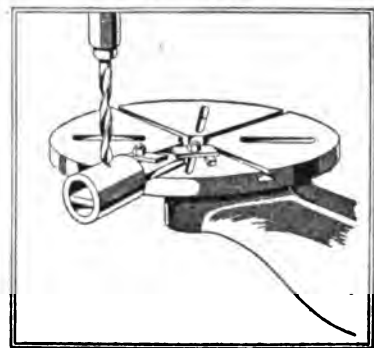

SAVES TOOLS WHEN  
SLOT DRILLING

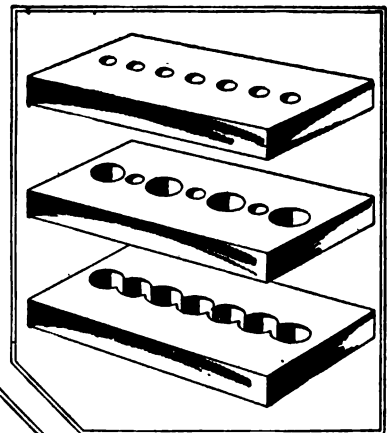

HEATING THE TAP  
ENLARGES IT



A VARIETY OF TIME-SAVING KINKS

# From a Small-Shop Notebook

By JOHN H. VAN DEVENTER

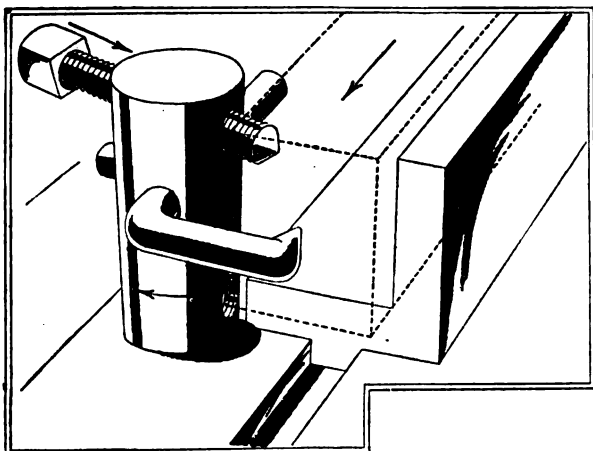

COMBINATION END STOP  
AND SIDE CLAMP

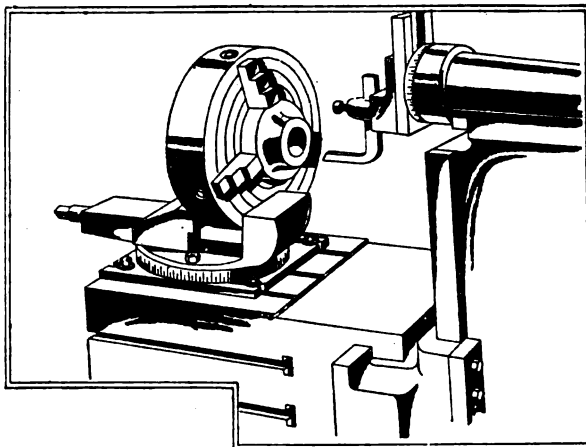

THE SHAPER BORROWS  
THE LATHE CHUCK

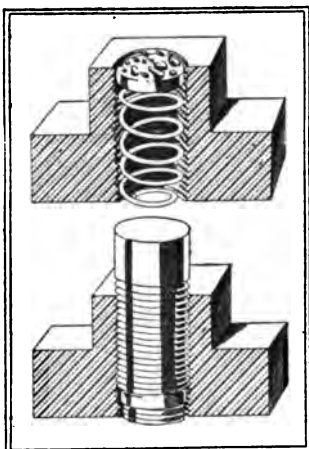

CHIP EJECTORS FOR  
TABLE-NUTS

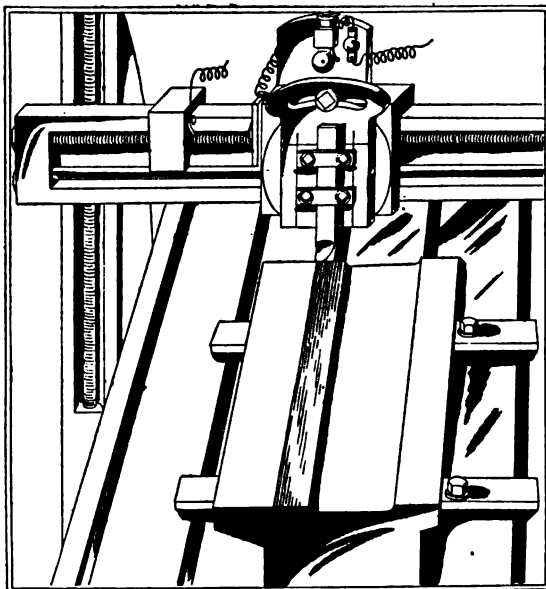

ONE MAN RUNNING TWO PLANERS NEEDS  
THIS SIGNAL

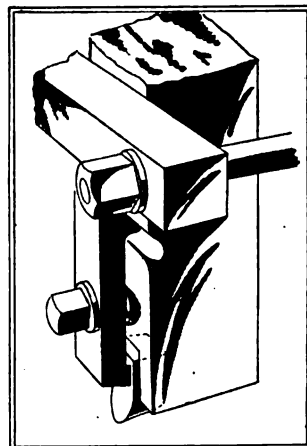

HOME-MADE STEEL  
ECONOMIZER

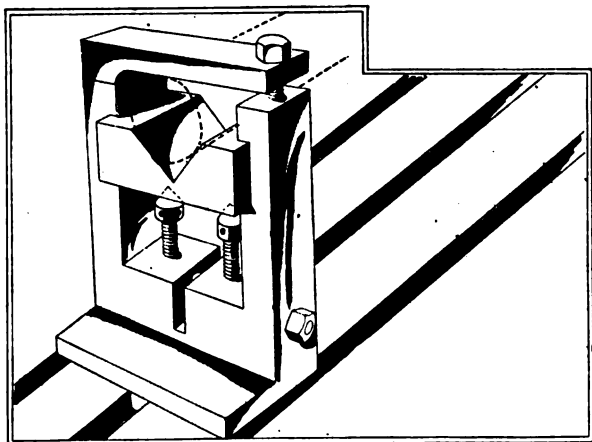

ADJUSTABLE V-BLOCK FOR THE PLANER

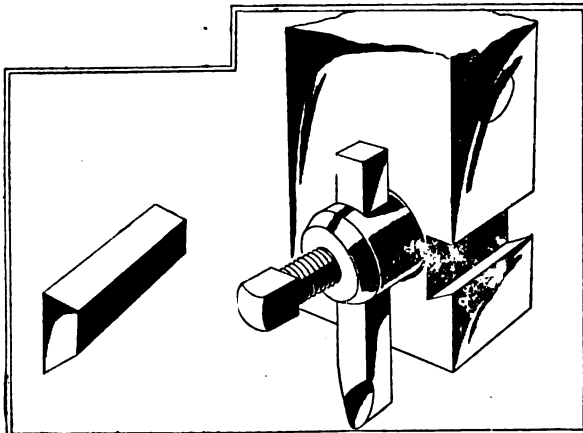

A TAPER GIB CURES LOOSE CLAPPERS



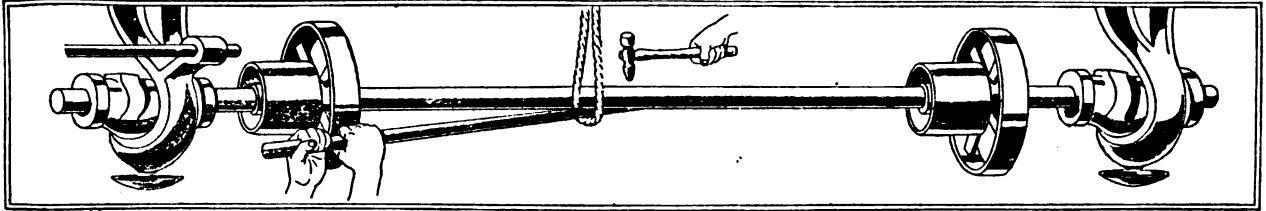

STRAIGHTENING SHAFTS IN PLACE

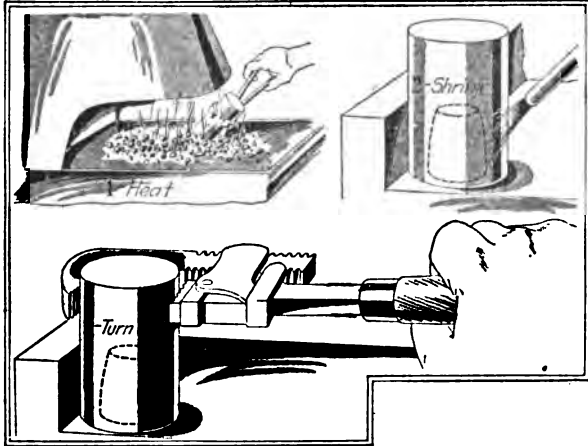

GETTING A GRIP ON A STUBBORN PIN

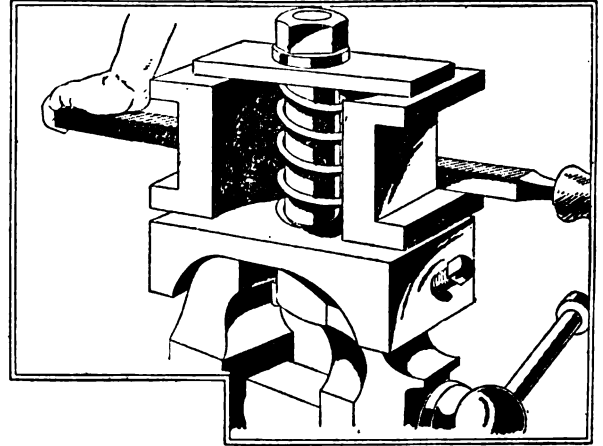

JIGS CAN BE USED ON VISES TOO

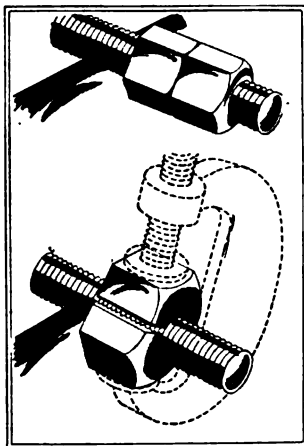

PULLING A STUD WITH A SPLIT NUT

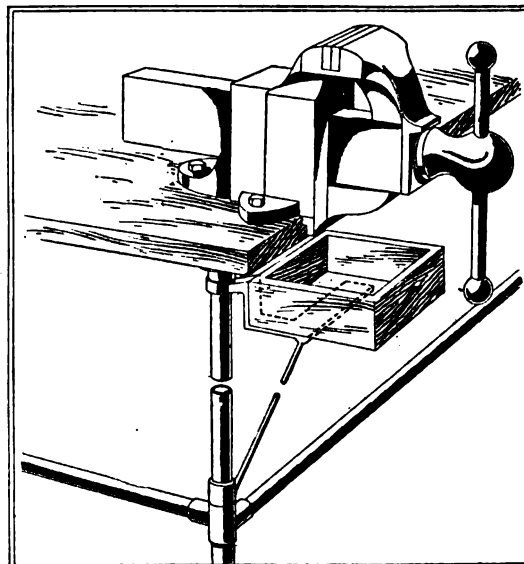

A SWINGING DRAWER FOR THE SMALL TOOLS

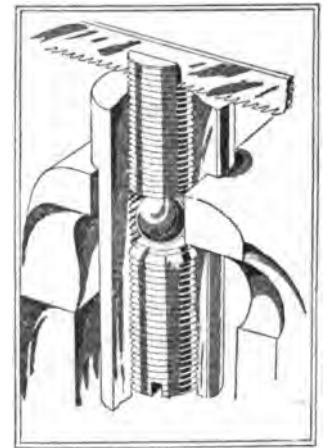

HOLDING SHORT SCREWS FOR SLOTTING

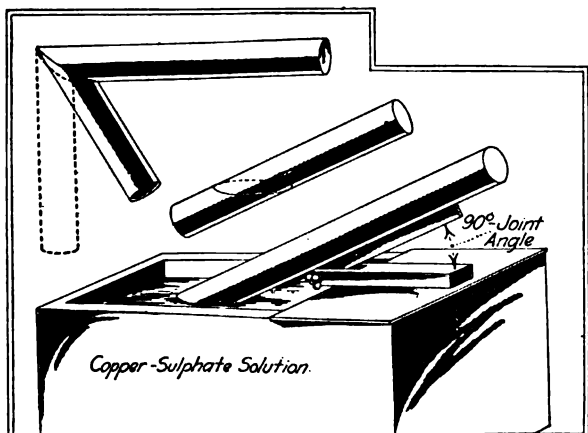

LAYING OUT MITERS ON BARS

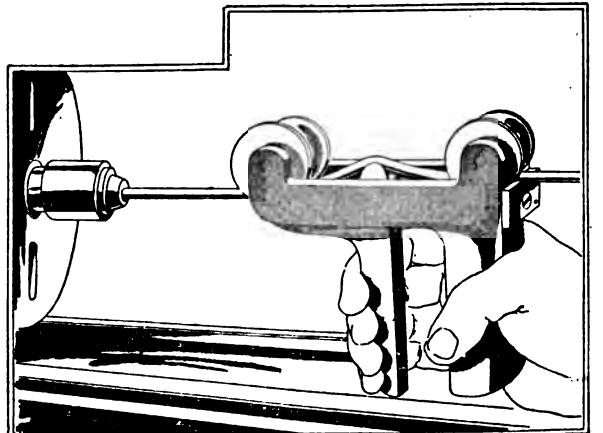

ADJUSTABLE WIRE KINK-REMOVER

# From a Small-Shop Notebook

BY JOHN H. VAN DEVENTER

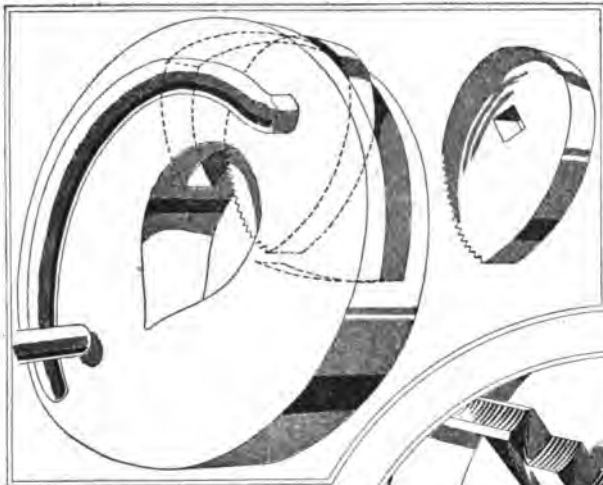

THIS DOG IS SAFE,  
BUT HAS A VICIOUS BITE

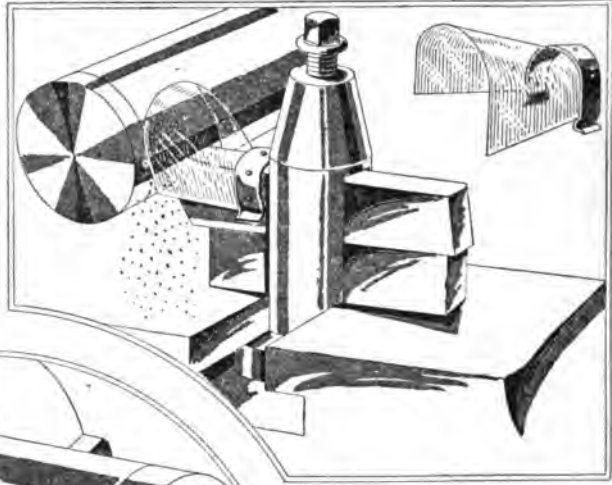

CELLULOID IS TRANSPARENT,  
BUT IT STOPS BRASS CHIPS

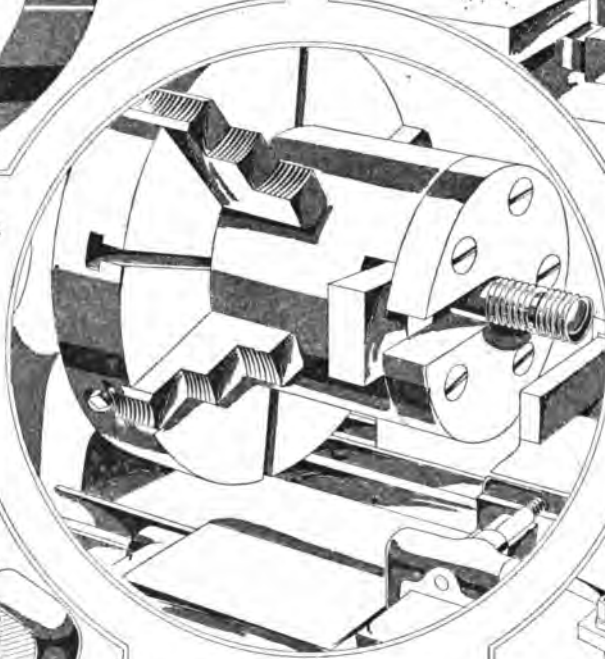

THIS WEDGE CHUCK MADE GOOD  
ON PIECEWORK

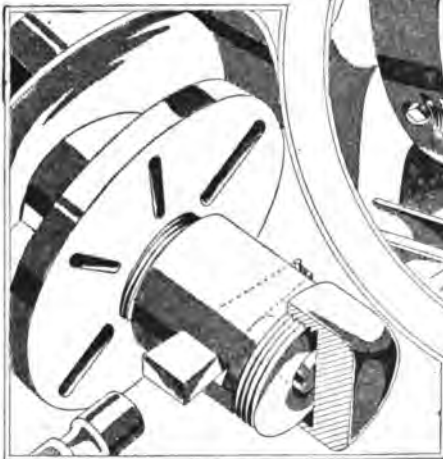

SCREW CAPS ARE HELD FIRMLY  
AND RELEASED QUICKLY

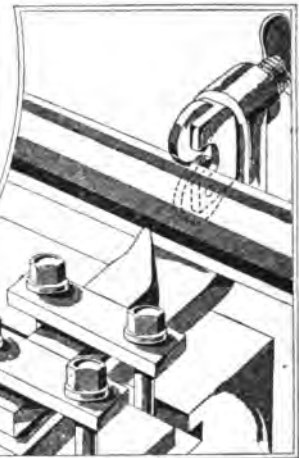

IMPROVED FOLLOW REST  
WITH SCREW ADJUSTMENT

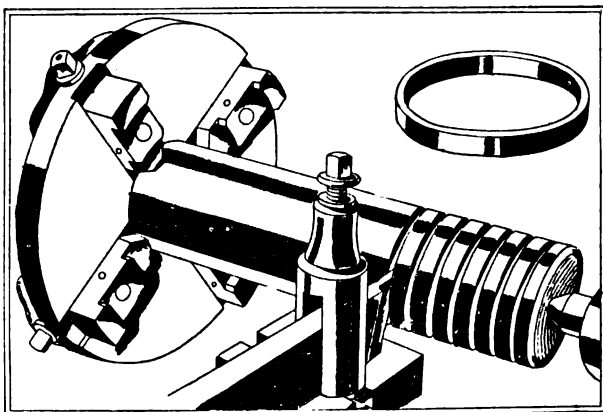

CUTTING BRASS OIL RINGS ON A WOOD ARBOR

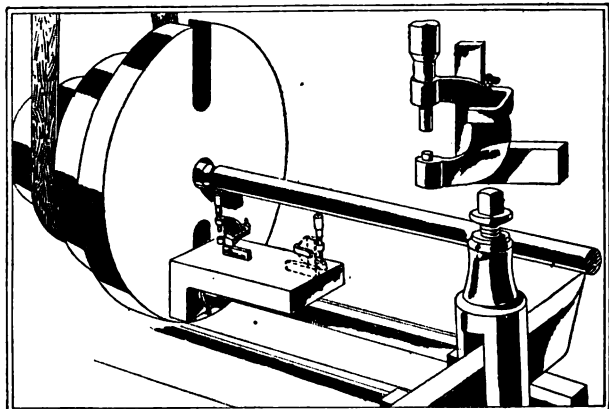

"MIKES" HELP TO SQUARE THE ANGLE PLATE

FROM A SMALL-SHOP NOTEBOOK

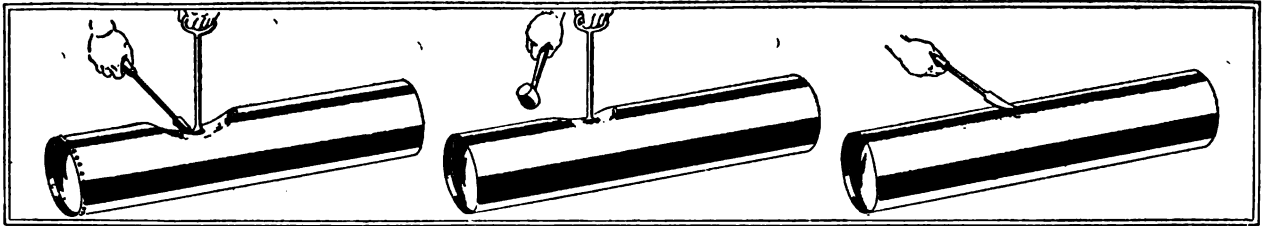

A HAMMER, SOLDERING IRON, PULL AND PATIENCE WILL TAKE A KINK OUT OF A CLOSED BOILER

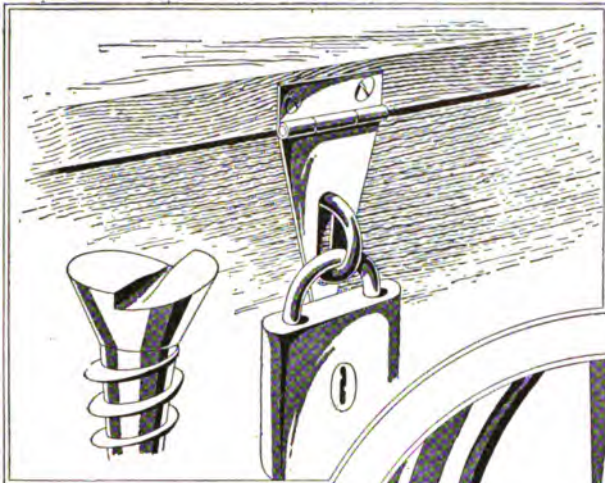

BURGLAR-PROOF WOOD SCREWS FOR CUPBOARDS

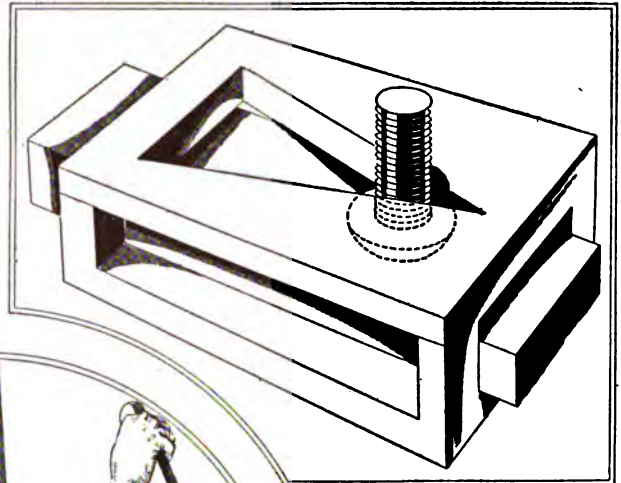

THIS TAPER CHUCKING BLOCK HELPS THE VISE HAND



PUTTING A HANDLE ON THE TEMPLET HELPS IN FITTING

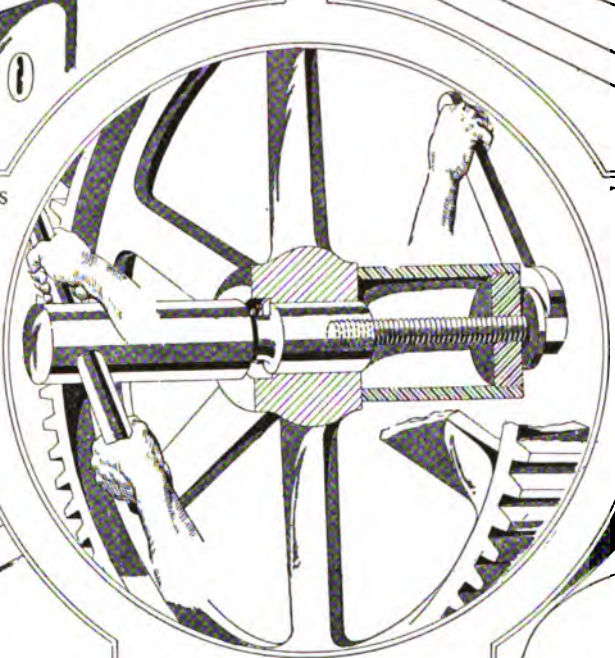

SOMETIMES A PULLEY OR FLYWHEEL MUST BE REBORED

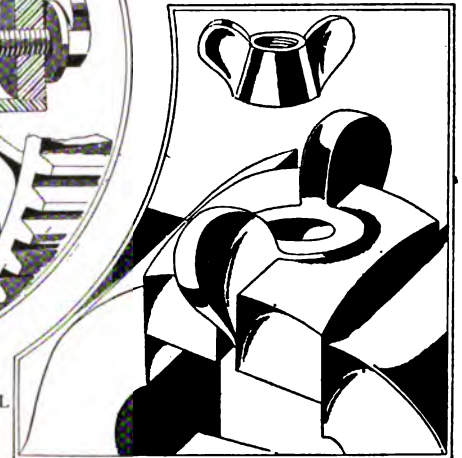

WING NUTS ARE HELD FIRMLY IN SPLIT SQUARE NUTS

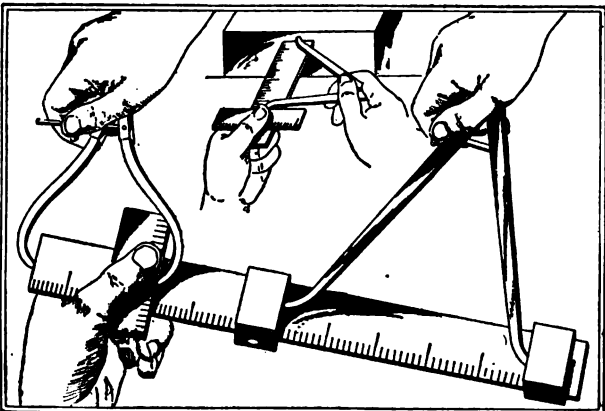

SLIDING BLOCKS ON SCALES AID IN SETTING CALIPERS

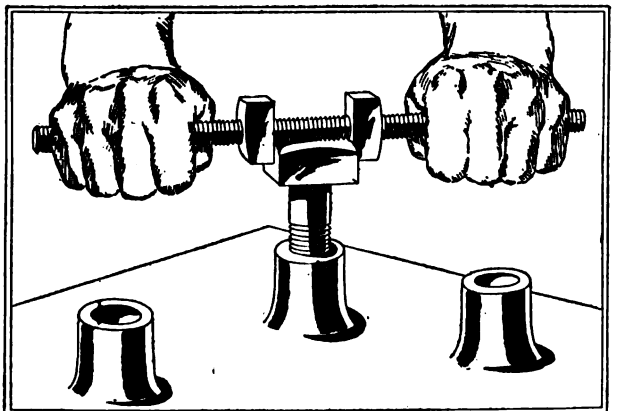

THIS EMERGENCY WRENCH IS HANDY TO HAVE AROUND

# From a Small-Shop Notebook

By JOHN H. VAN DEVENTER

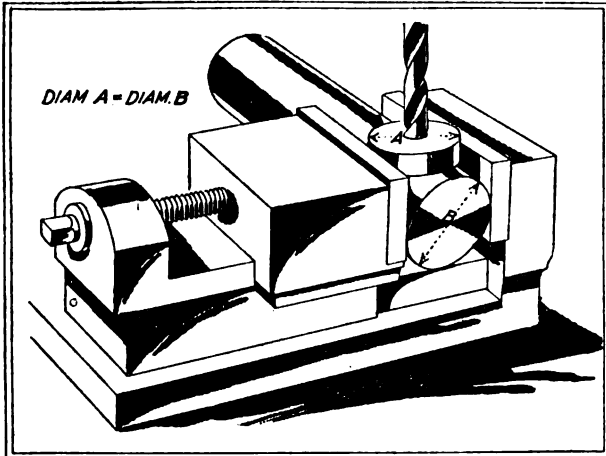

BOTH THE STOCK AND THE BUSHING ARE HELD BY THE JAWS

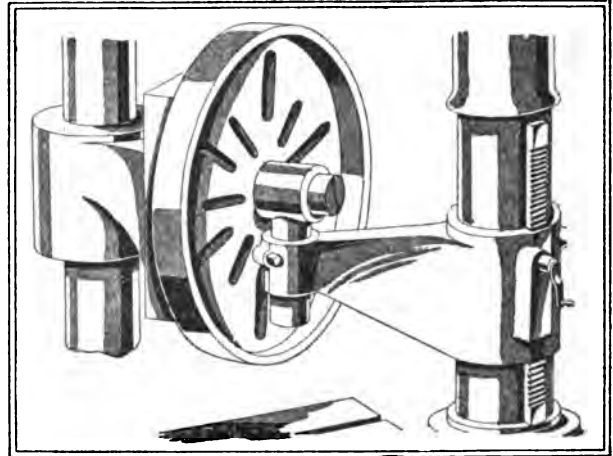

THIS SCHEME CONVERTS A "DRILL PRESS" INTO A BORING MACHINE

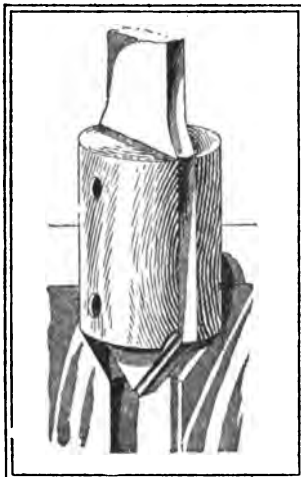

A SIMPLE FLAT REAMER WITH WOOD PACKING

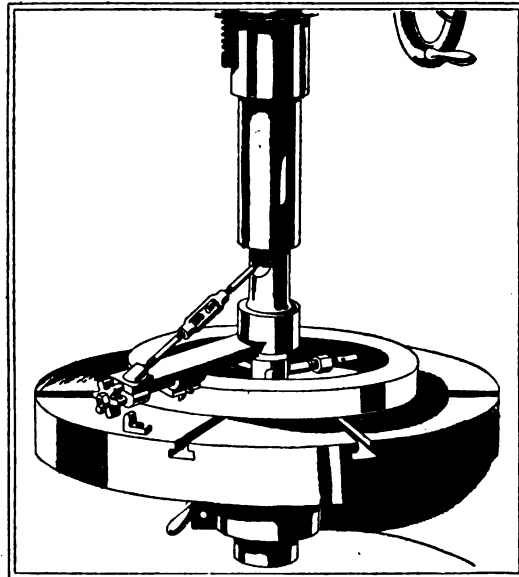

A "STAR FEED" FACING TOOL FOR THE DRILLING MACHINE

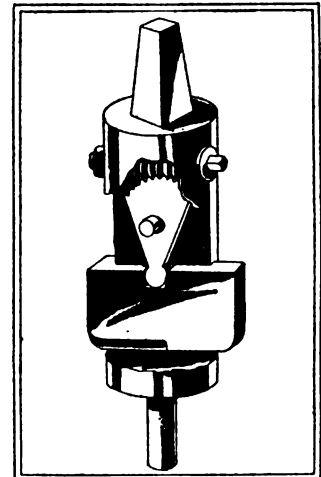

ADJUSTABLE BORING CUTTER FOR FINISHING HOLES

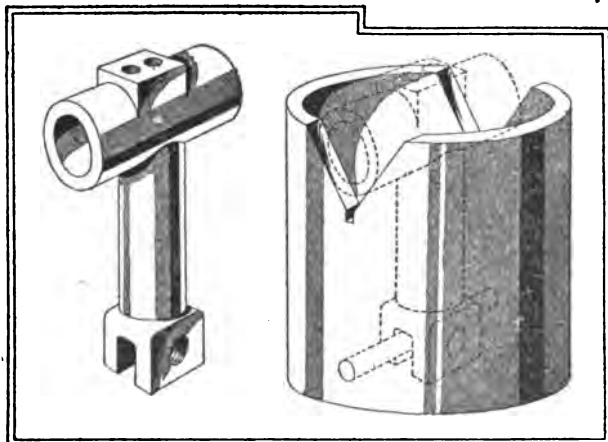

CONVENIENT V-BLOCKS ARE SOMETIMES MADE FROM ROUND PIPE

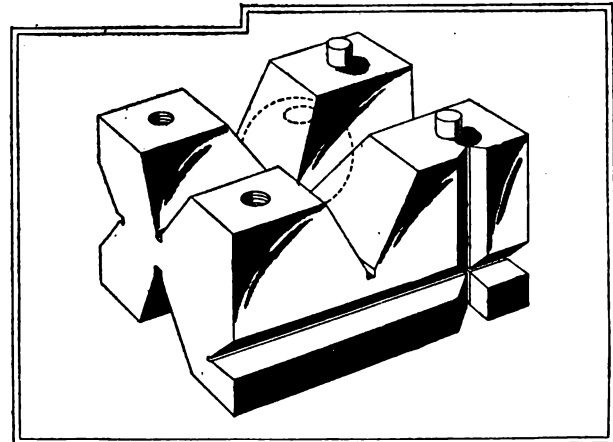

THIS UNIVERSAL V-BLOCK WILL HOLD ROUND STOCK AND SPHERES

HELPING THE DRILLING MACHINE TO EARN A PROFIT

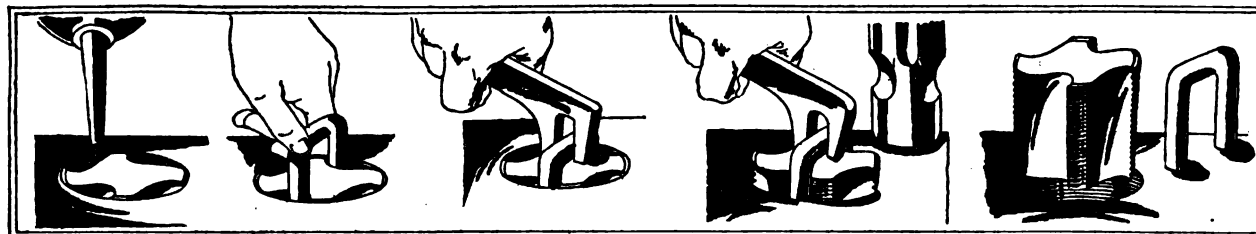

A WAY OF EXTRACTING BROKEN TAPS THAT IS WORTH REMEMBERING

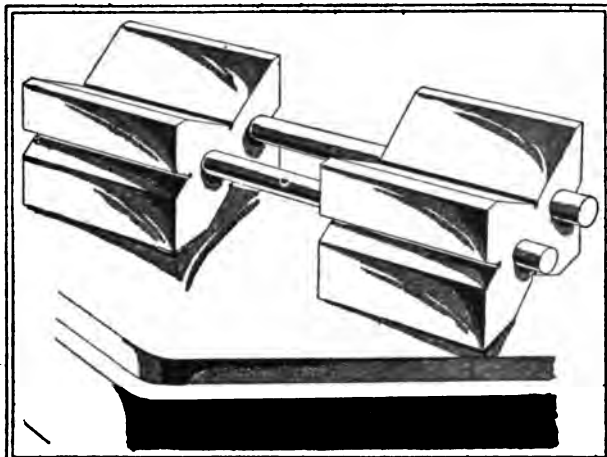

THESE V-BLOCKS ARE GUIDED BY TWO ROUND BARS

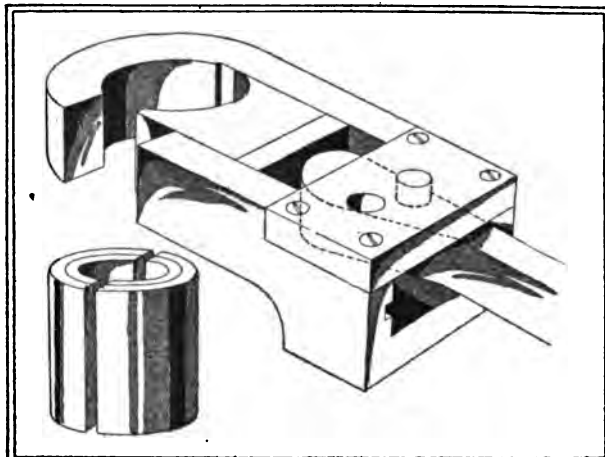

THIS PIPE WRENCH WILL NOT INJURE FINISHED WORK



A FIREPROOF RECEPTACLE FOR WELDING AND BRAZING TORCHES

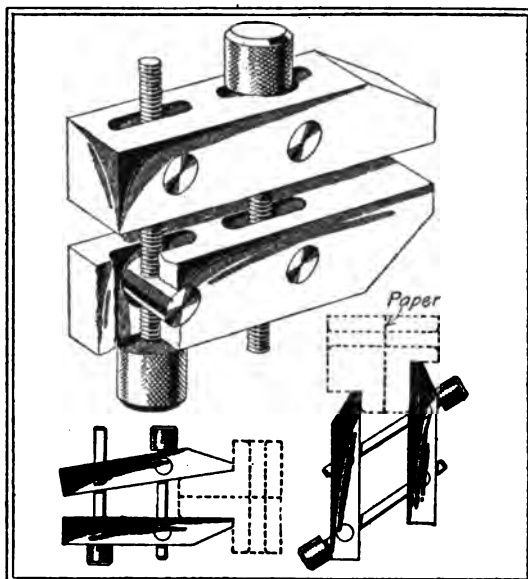

EVERY TOOL MAKER SHOULD HAVE A SET OF THESE CLAMPS

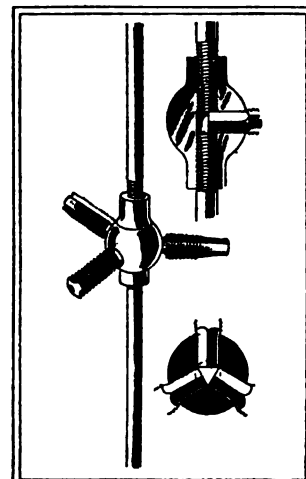

THIS TRIPLE TAP WRENCH BELIEVES IN PREPAREDNESS

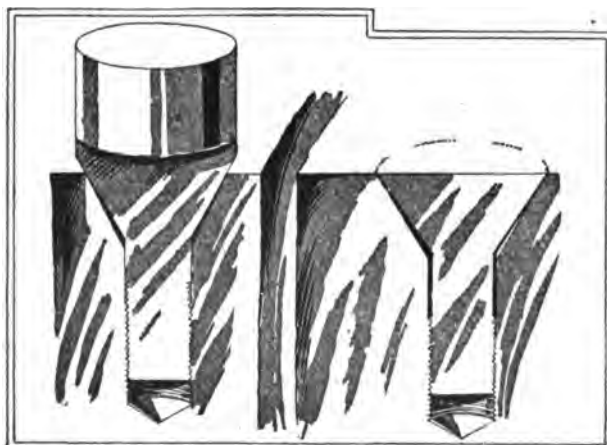

WHEN YOU MUST USE A "DUTCHMAN," PUT IT IN RIGHT

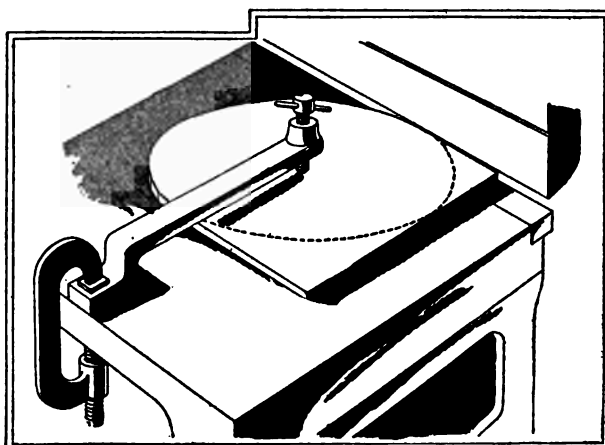

THIN DISKS MAY BE "TURNED" ROUND, ON A SQUARE SHEAR

# From a Small-Shop Notebook

By JOHN H. VAN DEVENTER

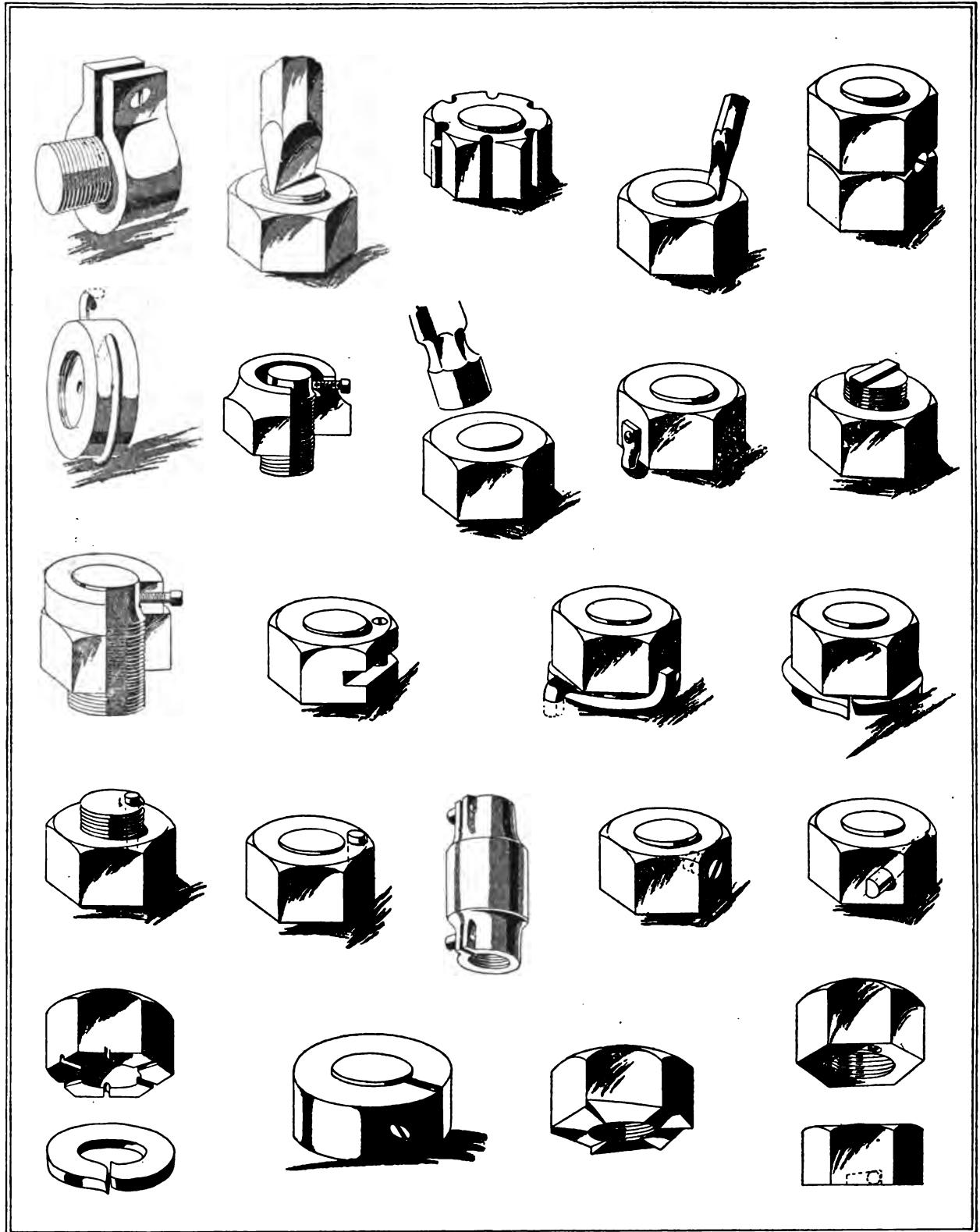

A WIDE VARIETY OF LOCKNUTS AND LOCKING DEVICES FOUND TO

FROM A SMALL-SHOP NOTEBOOK

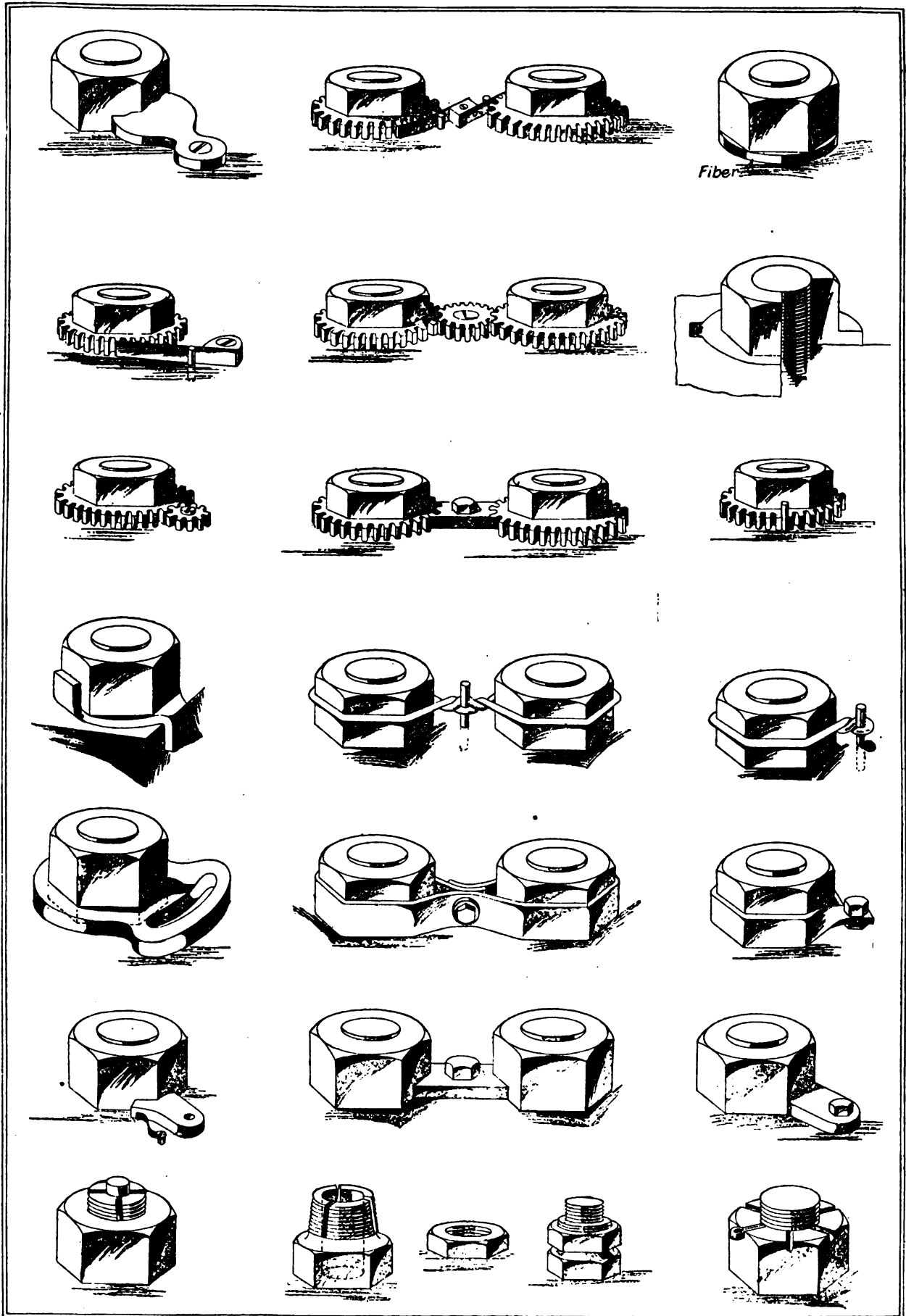

MEET PRACTICAL REQUIREMENTS IN VARIOUS CLASSES OF WORK

# From a Small-Shop Notebook

By JOHN H. VAN DEVENTER

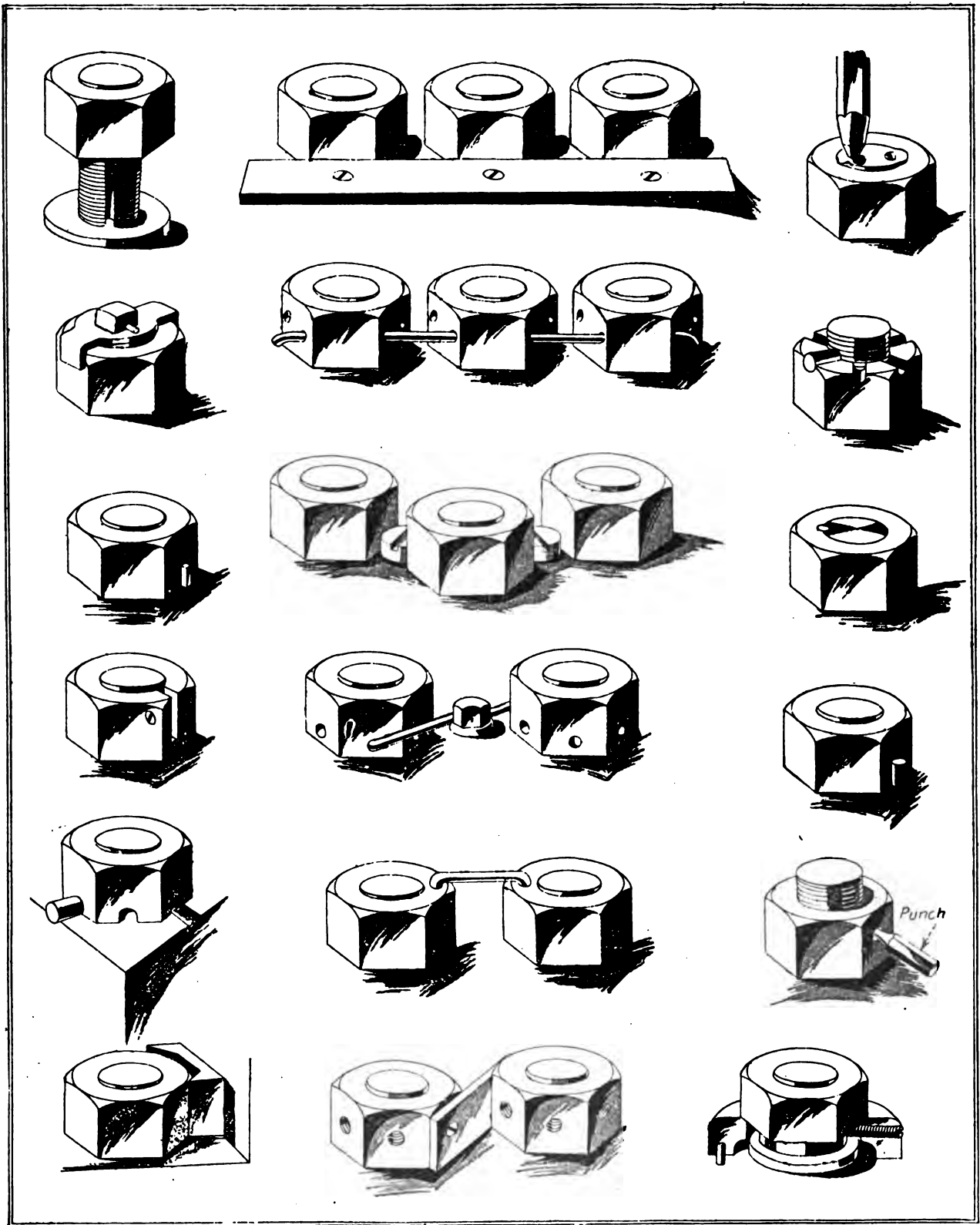

A NUT THAT WORKS LOOSE HAS LITTLE VALUE



FROM A SMALL-SHOP NOTEBOOK

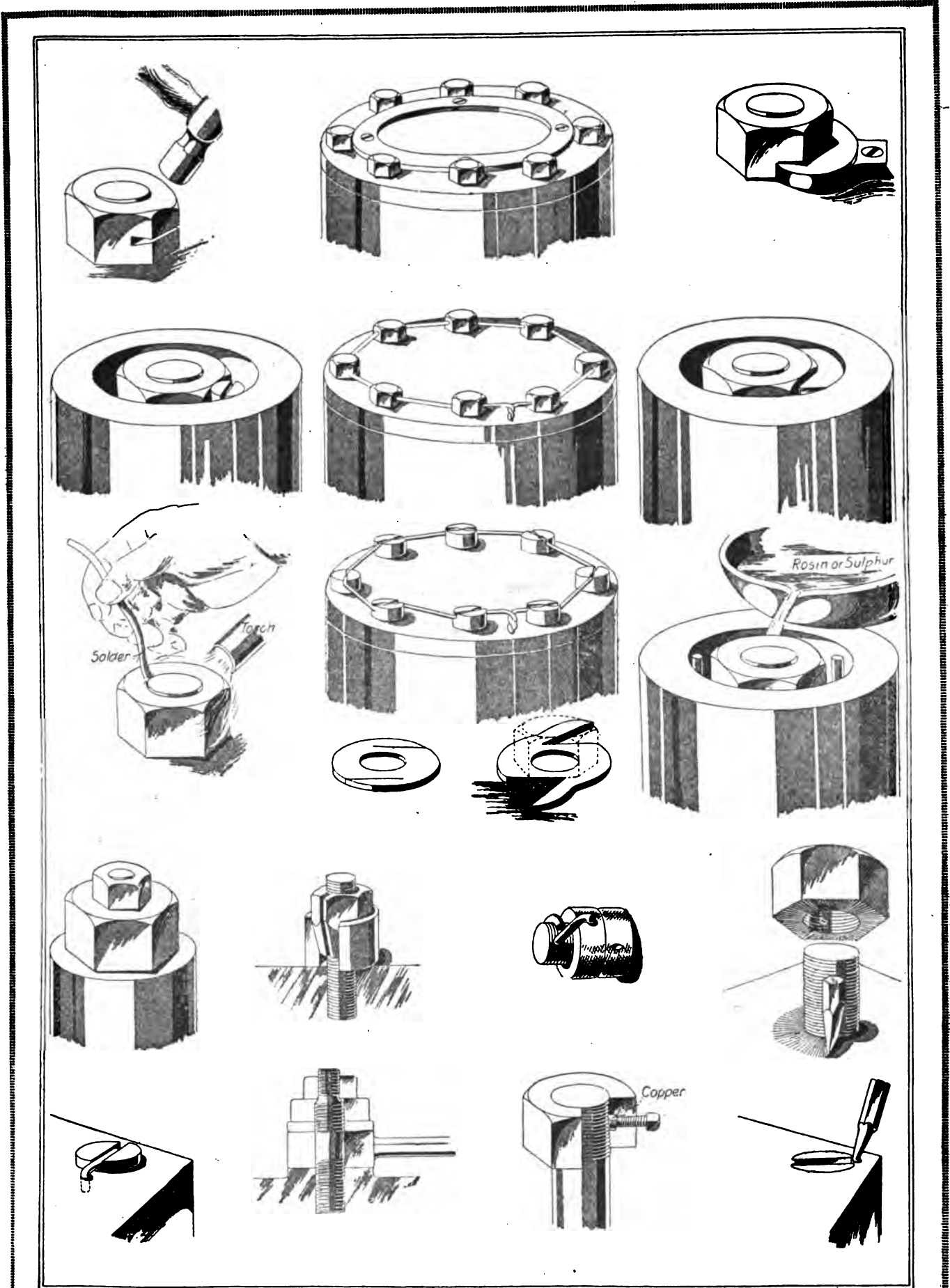

THESE PAGES SHOW A NUMBER OF WAYS OF LOCKING NUTS

# From a Small-Shop Notebook

By JOHN H. VAN DEVENTER

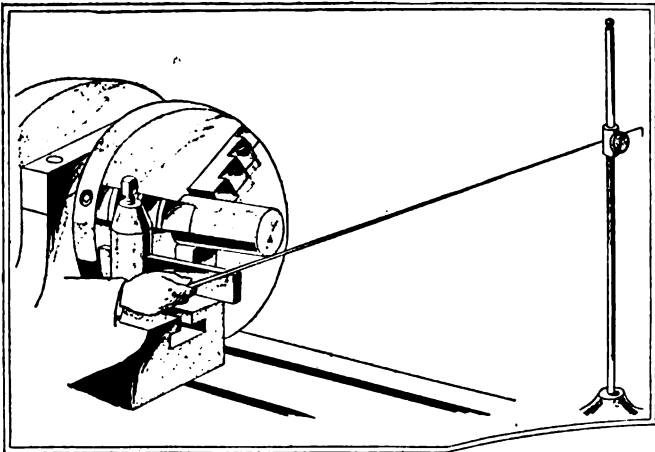

EMERGENCY INDICATOR

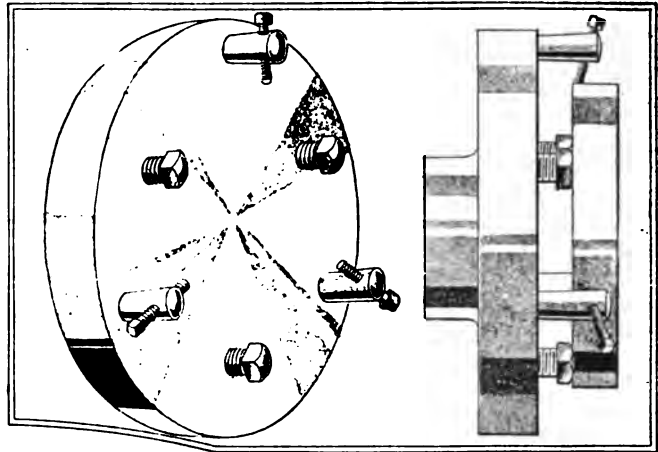

HOME-MADE CHUCK

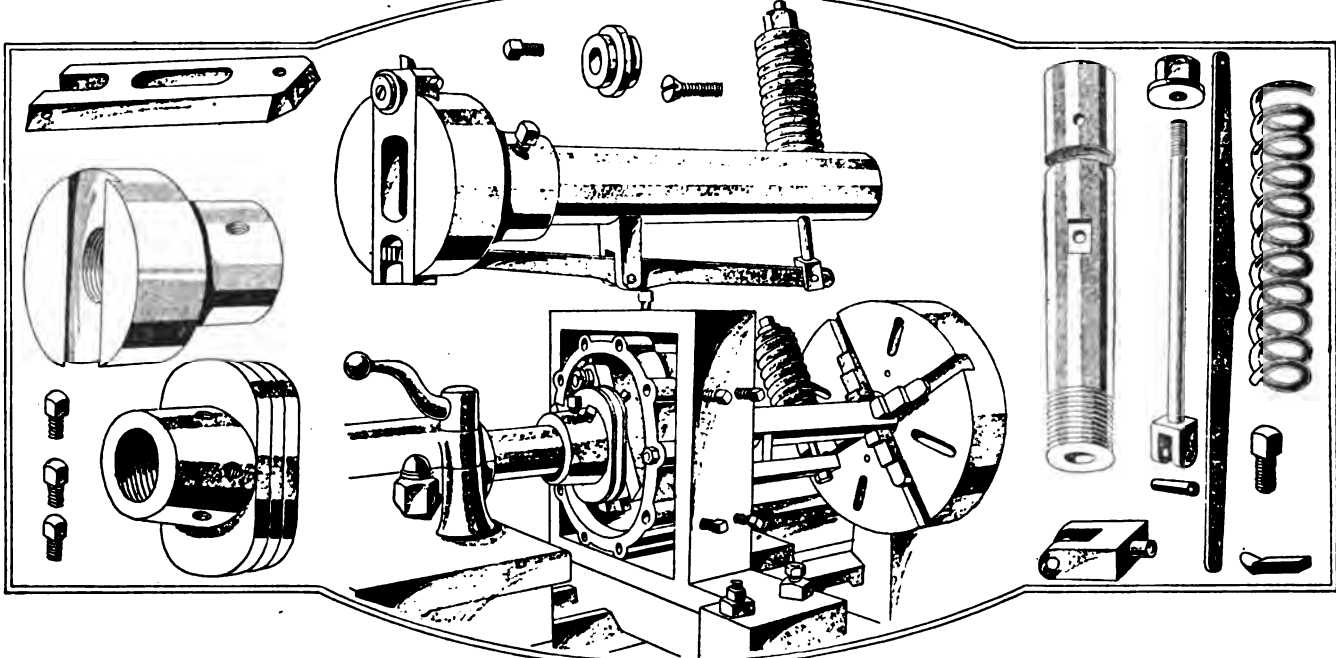

OVAL-TURNING DEVICE

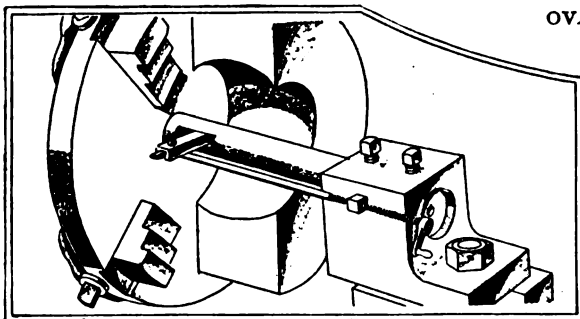

INTERNAL SPHERICAL TURNING

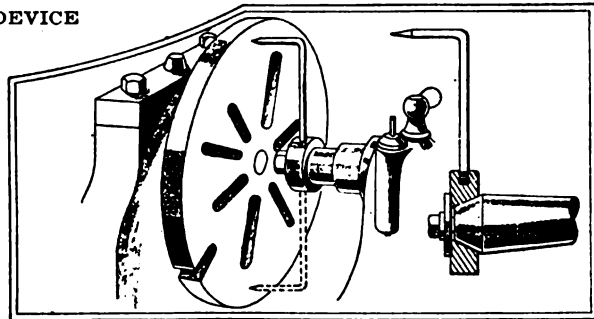

A FACEPLATE TESTER

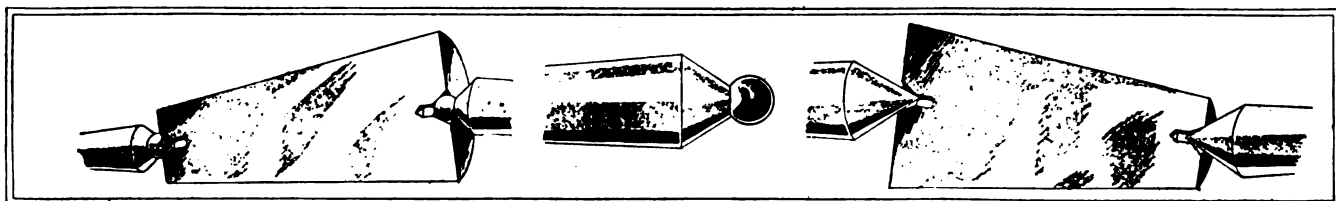

THE UTILITY OF BALL CENTERS IN TAPER TURNING

FROM A SMALL-SHOP NOTEBOOK

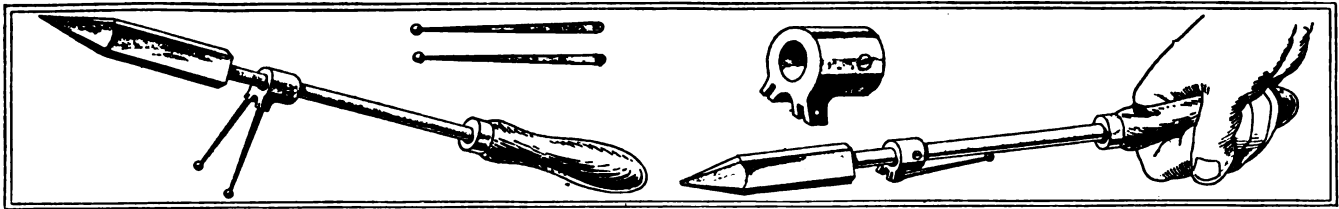

KEEP YOUR SOLDERING IRONS CLEAN AND DON'T BURN THE TABLES

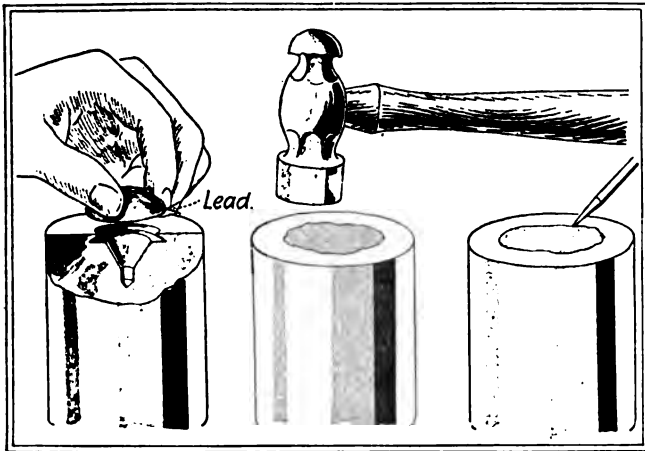

"SAFETY FIRST" ON MANDREL CENTERS

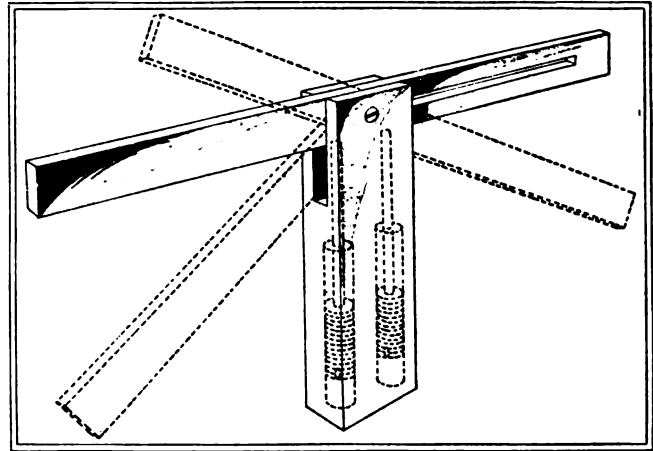

AN "ALL-IN-ONE" ANGLE SQUARE

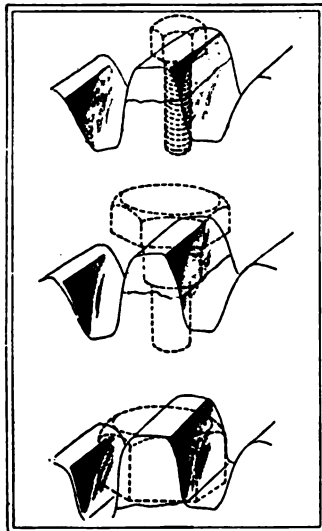

GEAR DENTISTRY

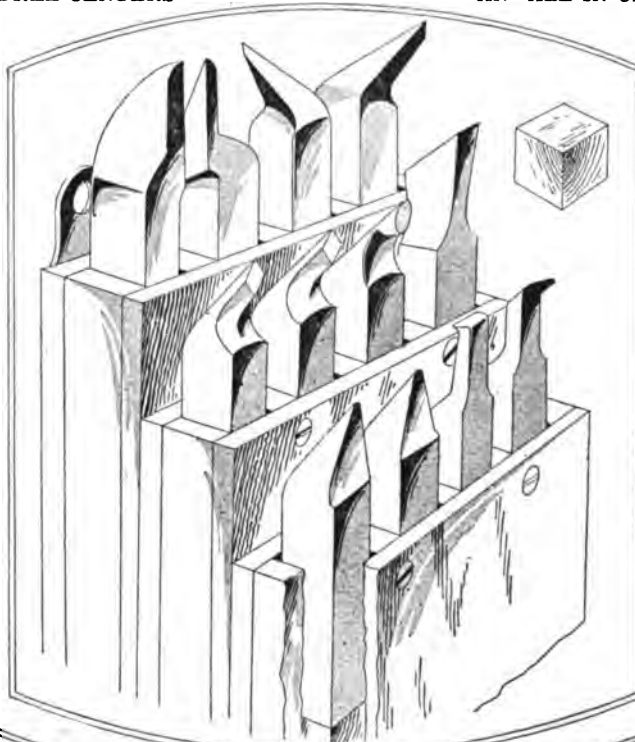

AVOID HUNTING FOR TOOLS

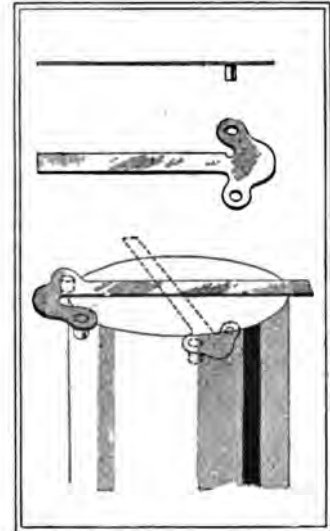

A CENTER SQUARE

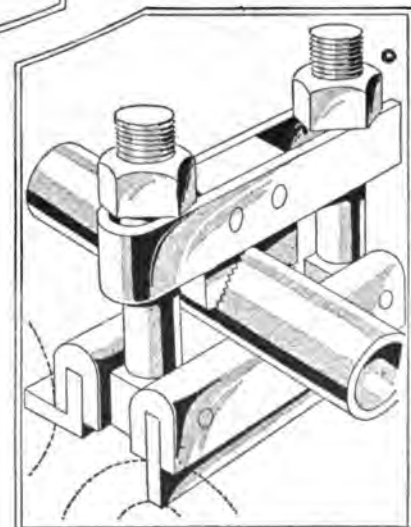
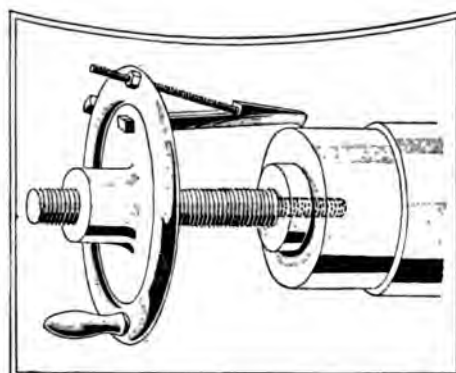
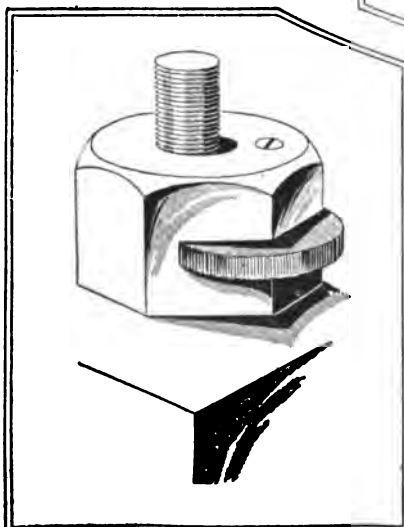

# From a Small-Shop Notebook

BY JOHN H. VAN DEVENTER

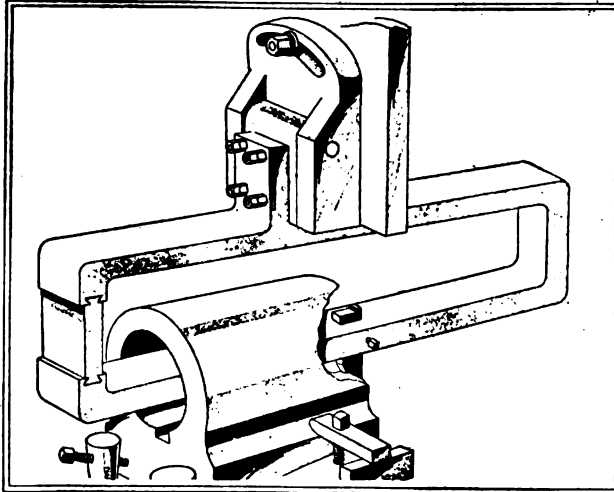

A RIGID RIG FOR KEYWAYING

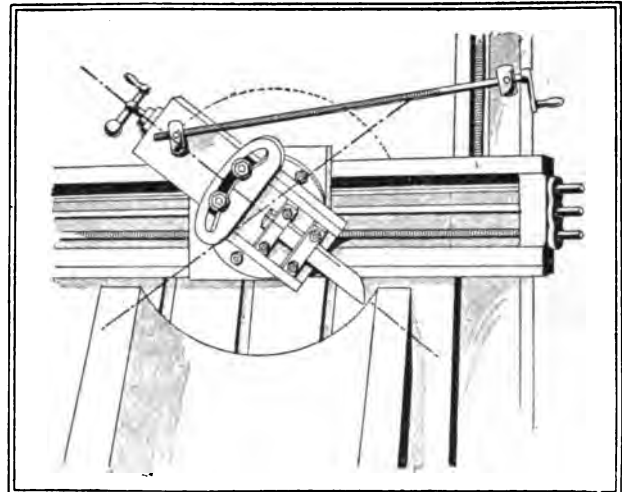

PLANING A CONCAVE RADIUS

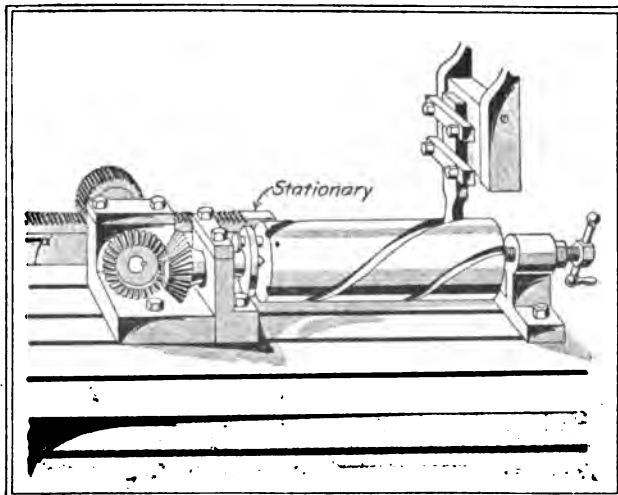

CUTTING SPIRALS ON PLANER

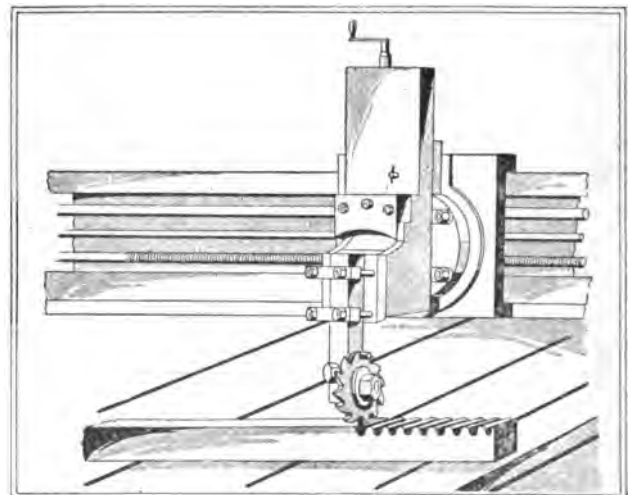

RACK-CUTTING ON THE PLANER

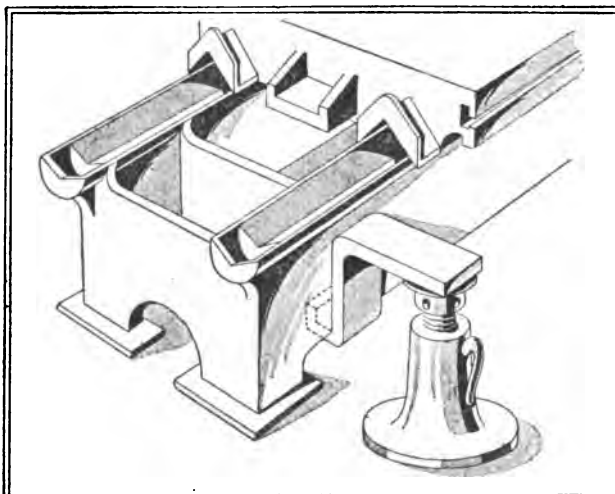

"SHORTENING" A JACK

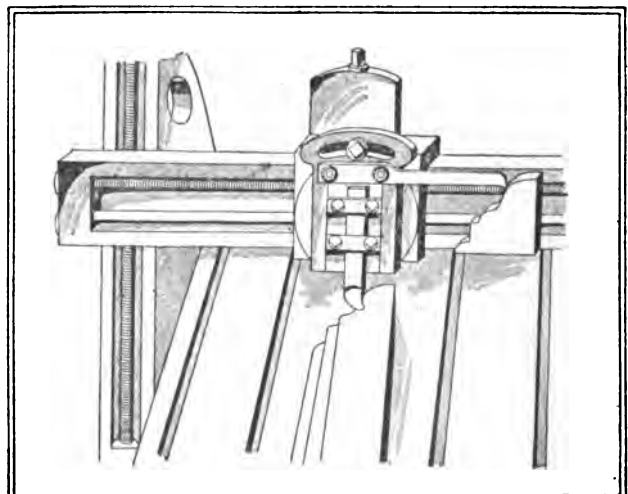

PLANING TO A TEMPLAT

SOME USEFUL PLANER KINKS

FROM A SMALL-SHOP NOTEBOOK

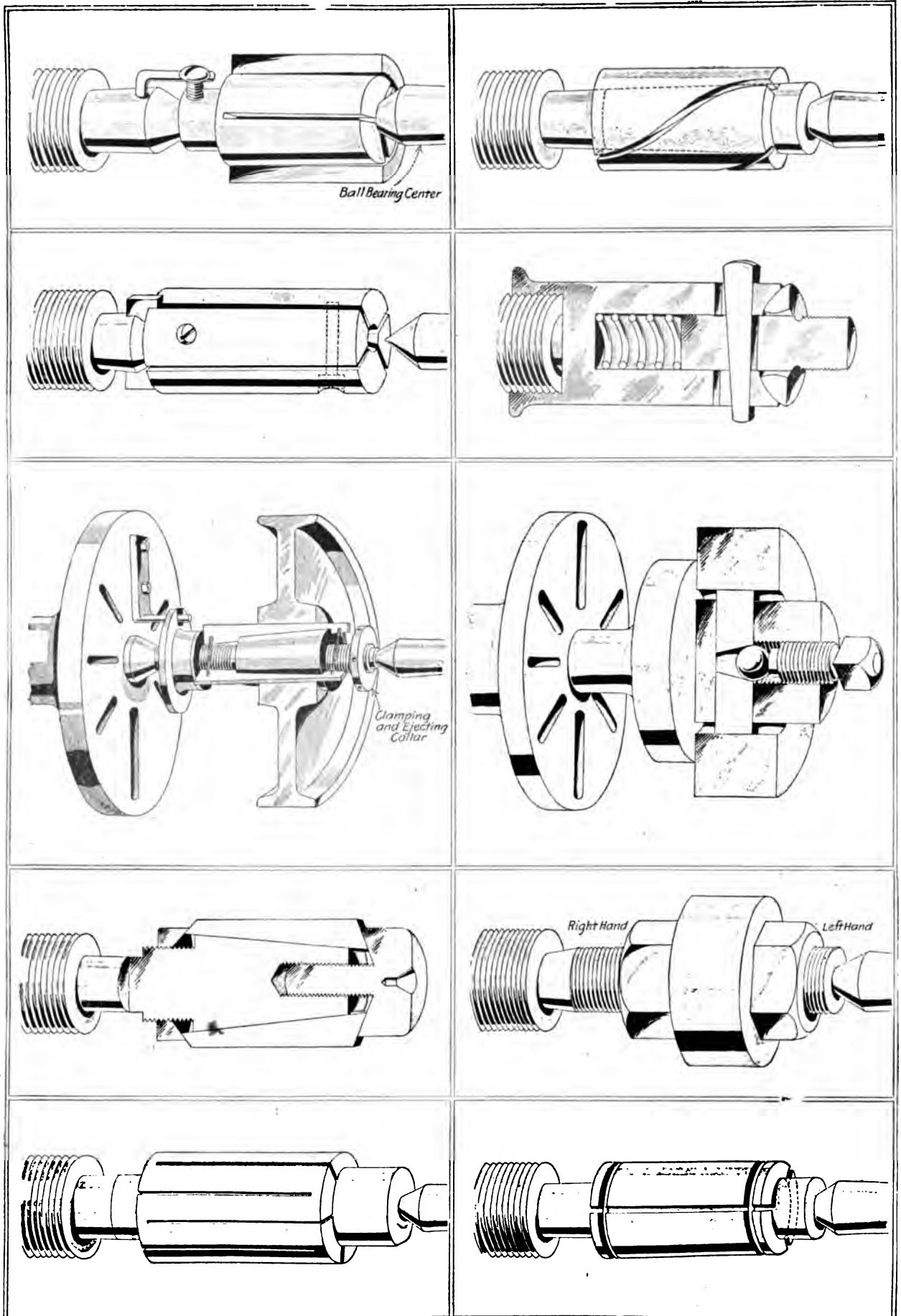

A VARIETY OF EXPANDING ARBORS

# From a Small-Shop Notebook

By JOHN H. VAN DEVENTER

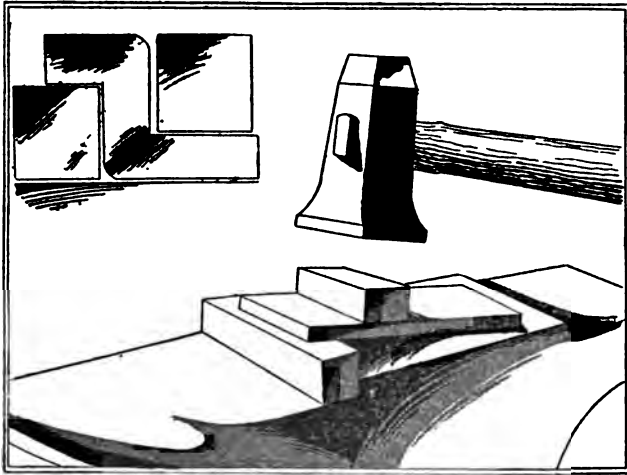

BENDING WITH FLATTER AND BLOCKS

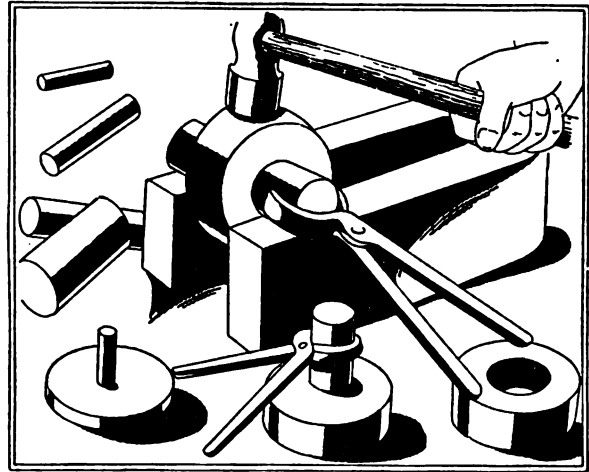

ONE METHOD OF MAKING RINGS

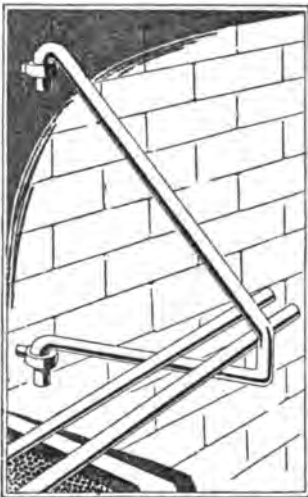

KEEPS THE BAR STOCK  
HIGH AND DRY

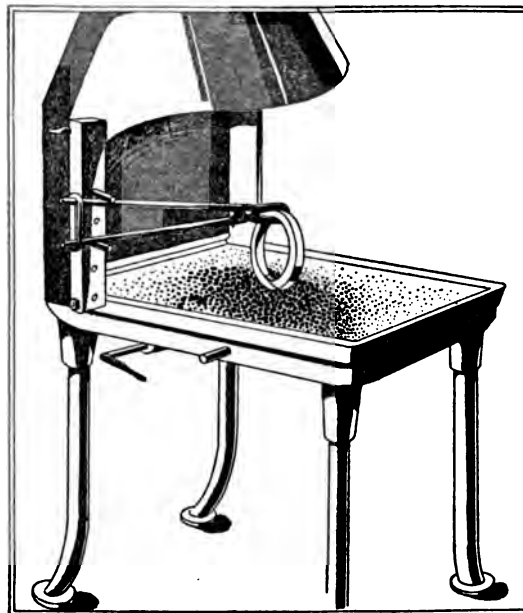

THE SMALL-SHOP SMITH'S HELPER

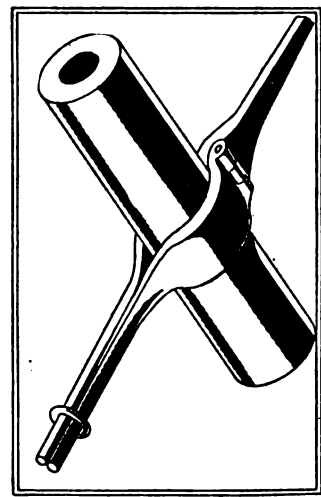

DOUBLE-END TONGS THAT  
WILL NOT SLIP

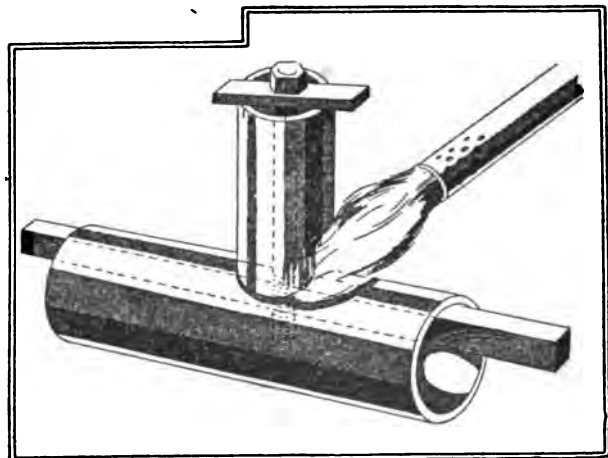
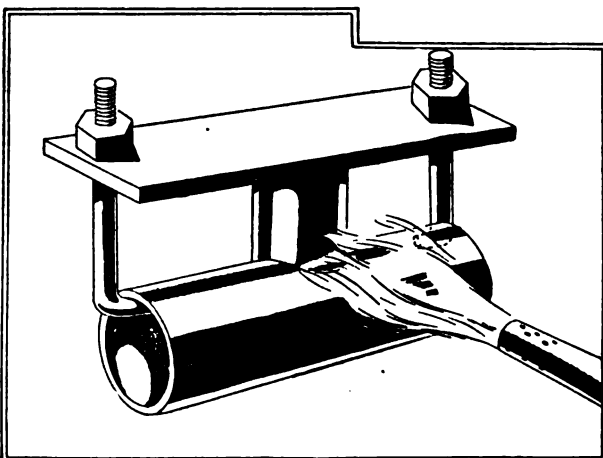

TWO LITTLE DEVICES THAT COME IN HANDY WHEN BRAZING PIPE  
THE SMALL-SHOP BLACKSMITH IS A BUSY MAN

FROM A SMALL-SHOP NOTEBOOK

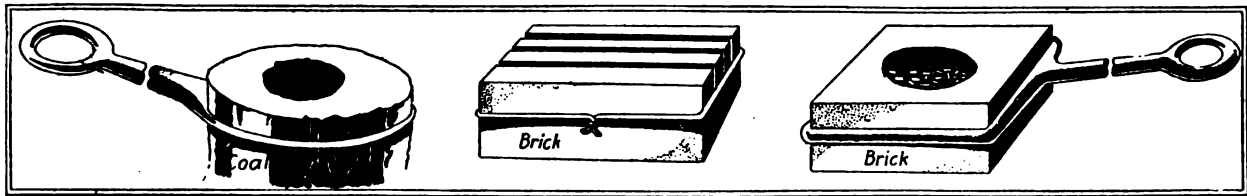

FOR HEATING SMALL PARTS THESE SIMPLE TRICKS ARE USEFUL

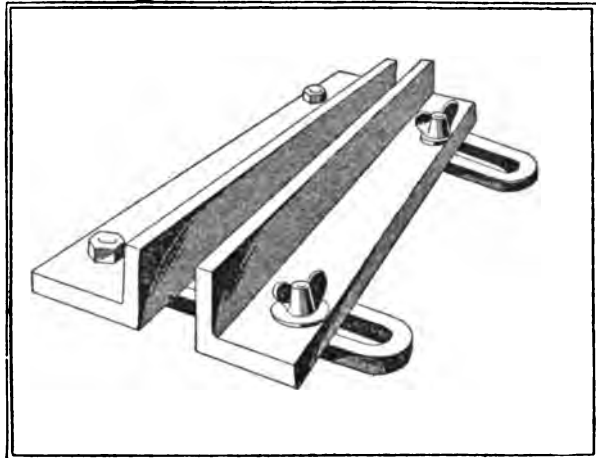

BLACKSMITH'S TAPER GAGE

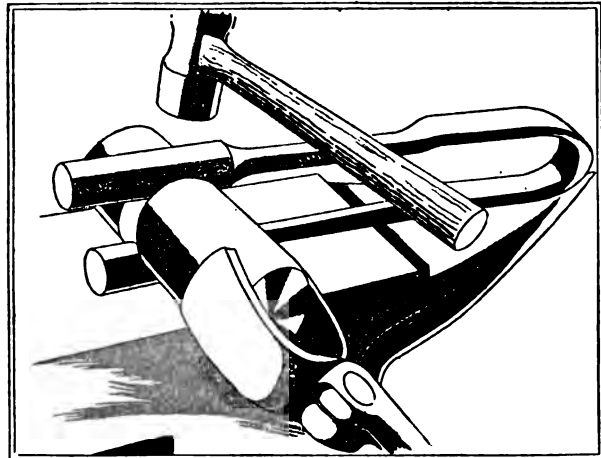

SPRING FULLERS ARE HANDY

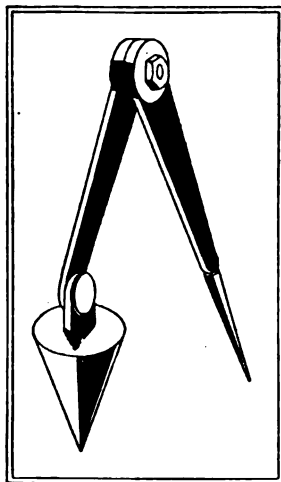

DIVIDERS FOR RING WORK

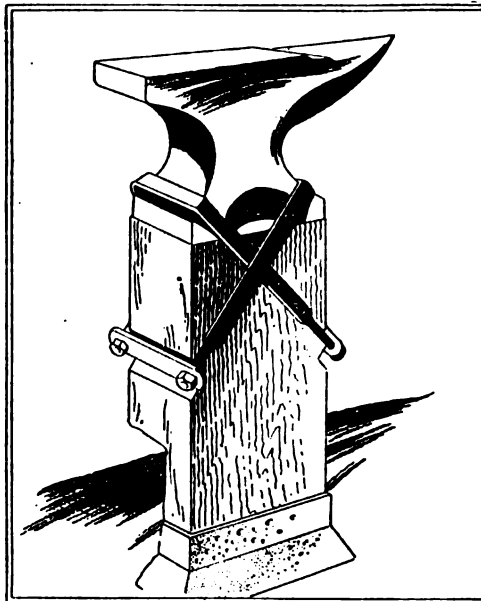

KEEPS THE ANVIL FROM JUMPING AND KILLS VIBRATION

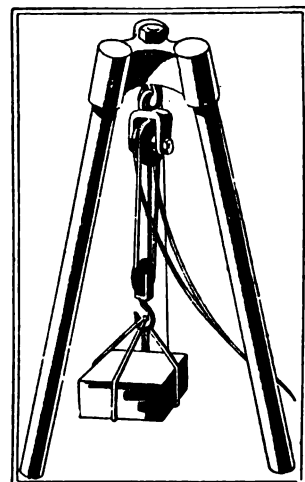

CRANE MADE FROM IRON PIPE

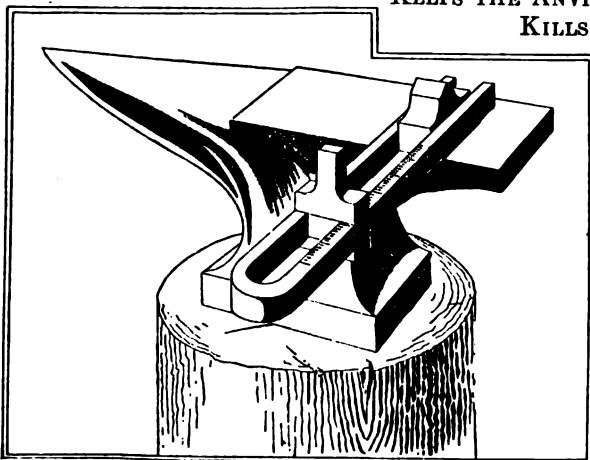

STOCK-MEASURING GAGE FOR ANVIL

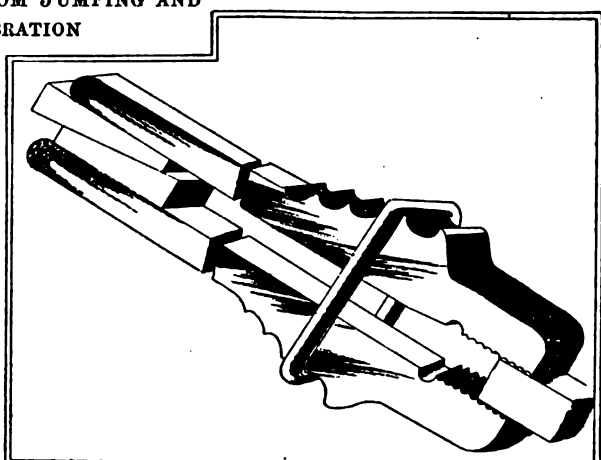

THESE TONGS TAKE A LARGE OR A SMALL BITE

THESE USEFUL KINKS WILL HELP HIM SAVE MONEY

# From a Small-Shop Notebook

By JOHN H. VAN DEVENTER

PATTERN TURNING ON THE PLANER

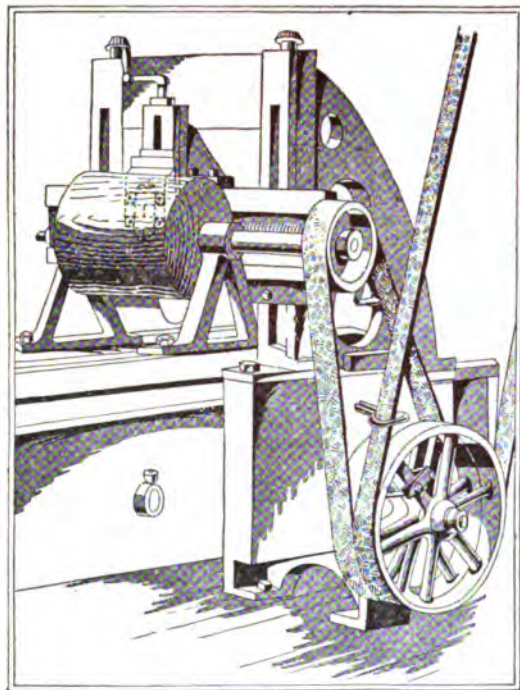

QUICK DETACHABLE PLANER BOLTS

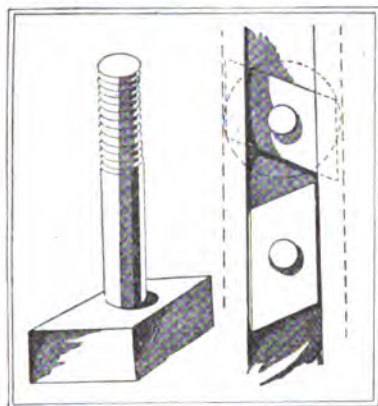

HANDY CLAMP FOR BAR KEYWAYING

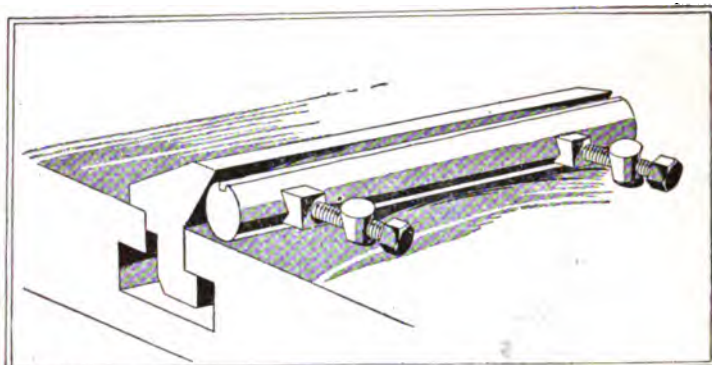

PLANING THE OVER-SIZE JOB

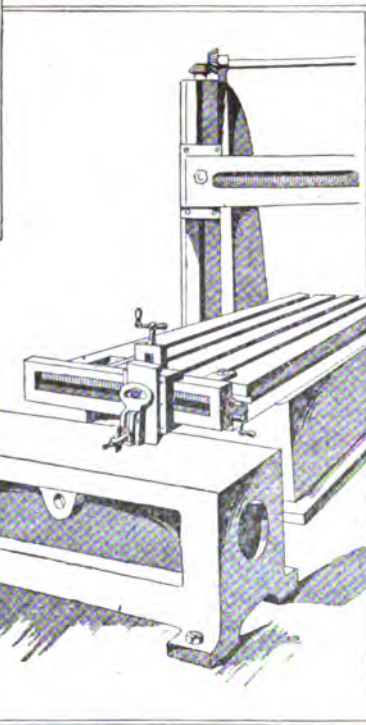

THE RAM OF THE SHAPER MAKES A FAIR PUNCH FOR THIN STOCK

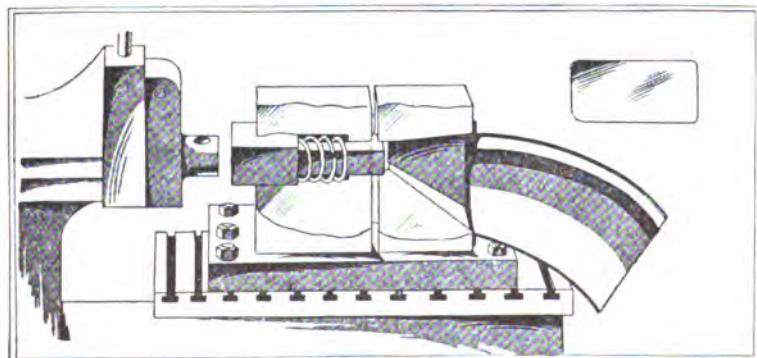

A TOOL THAT WILL CUT SLOTS

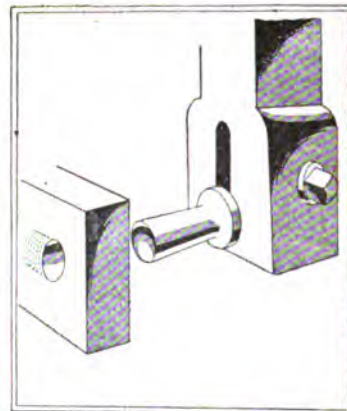

A HOME-MADE FOOT-DRIVEN SHAPER

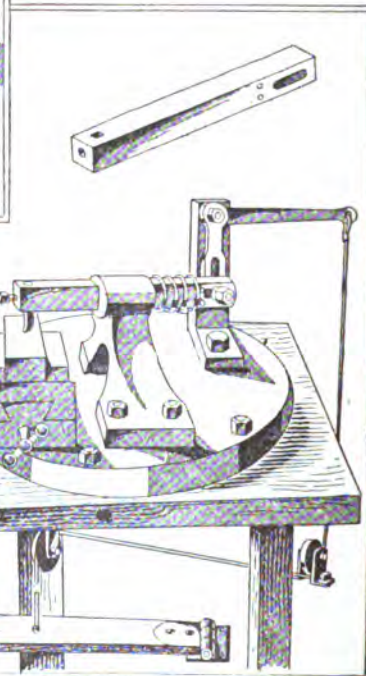

PLANER AND SHAPER DEVICES THAT SAVE MONEY



FROM A SMALL-SHOP NOTEBOOK

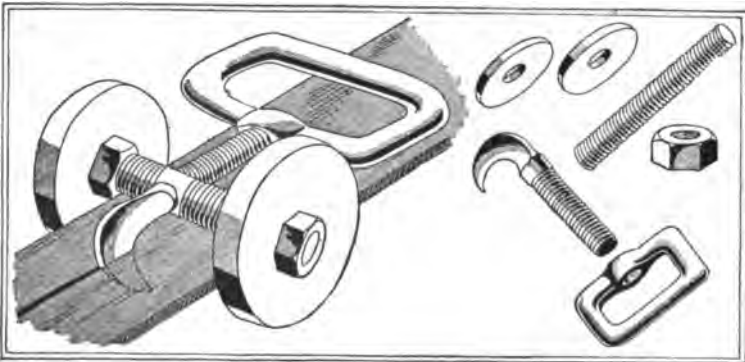
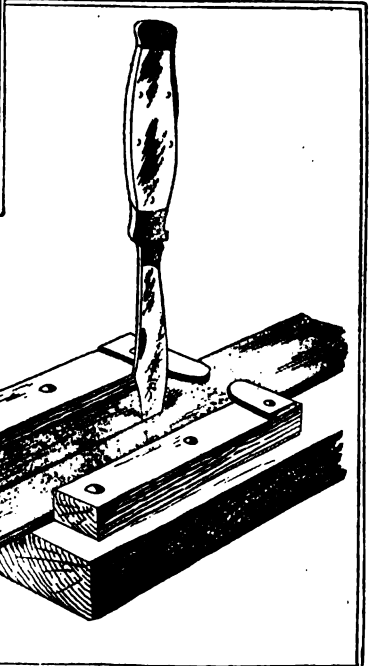
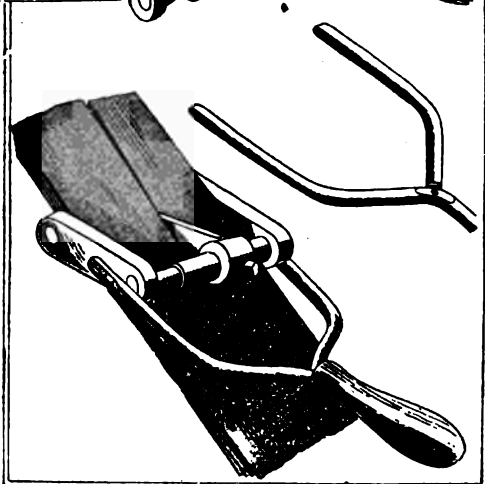
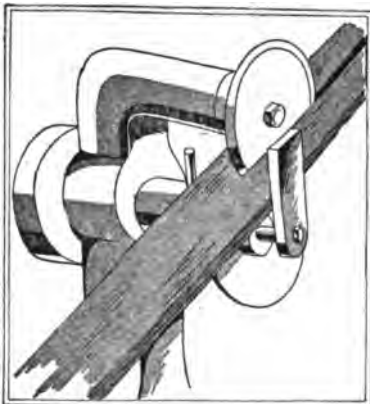
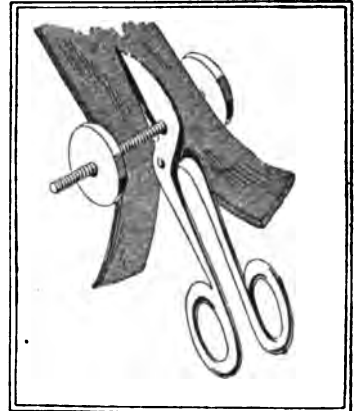
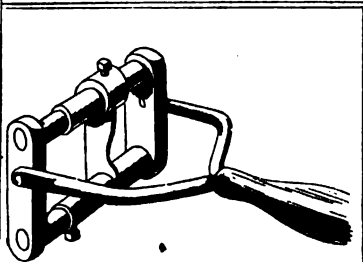
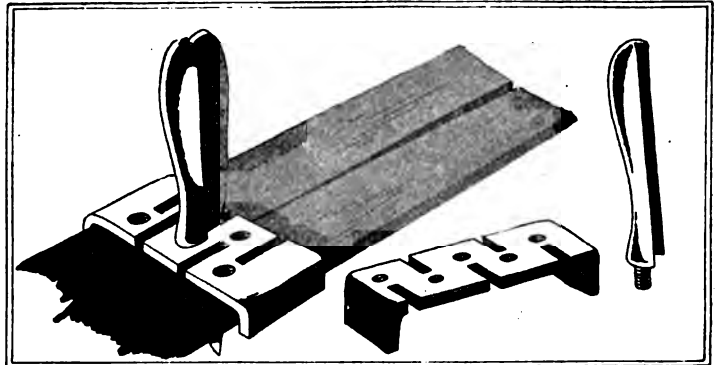
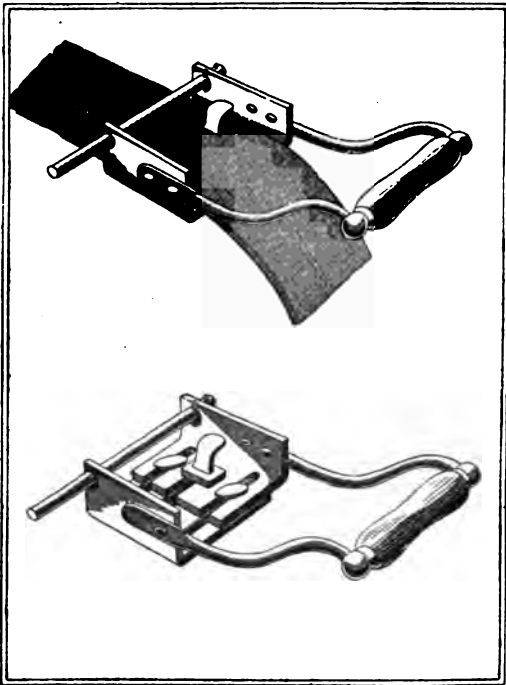

A COLLECTION OF BELT-CUTTING DEVICES

# MAKING SMALL SHOPS PROFITABLE

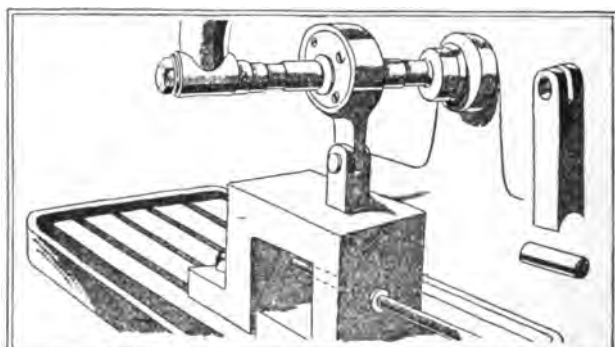
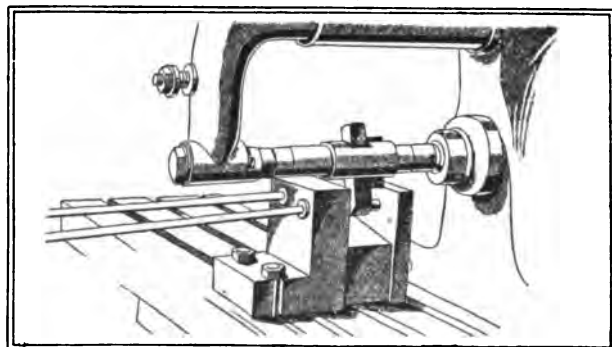
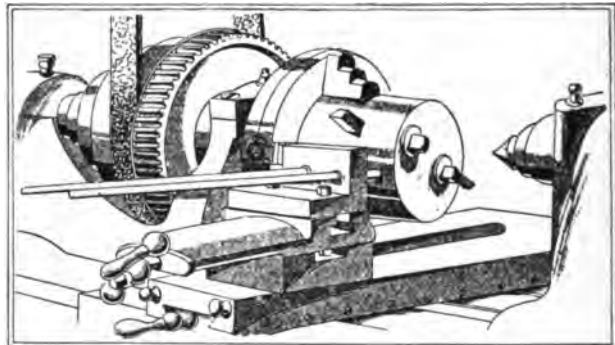
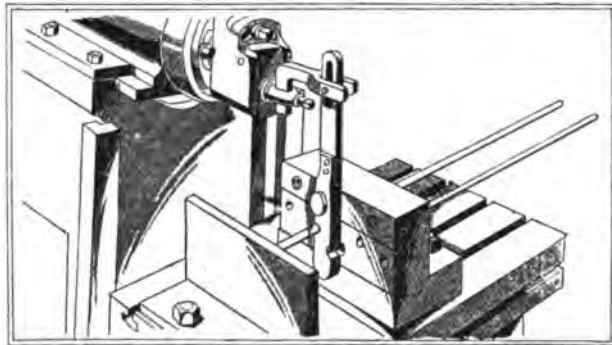
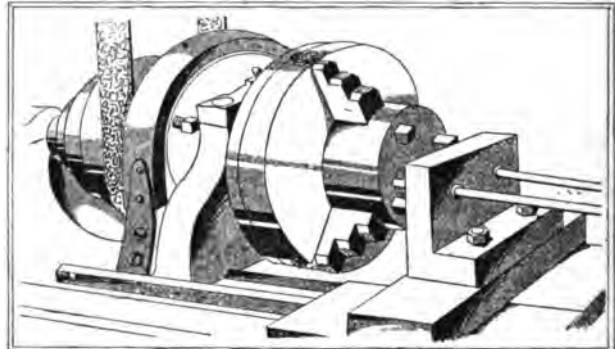
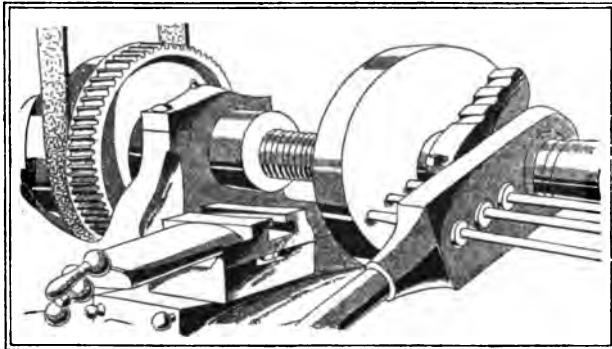
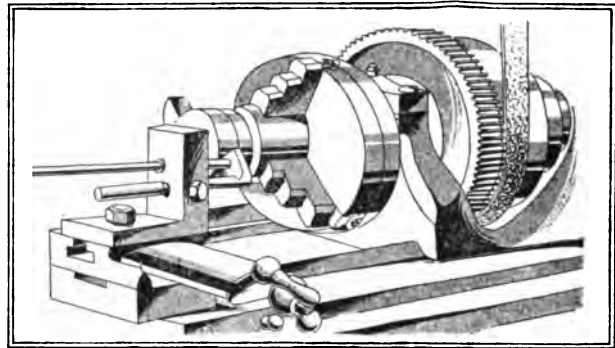
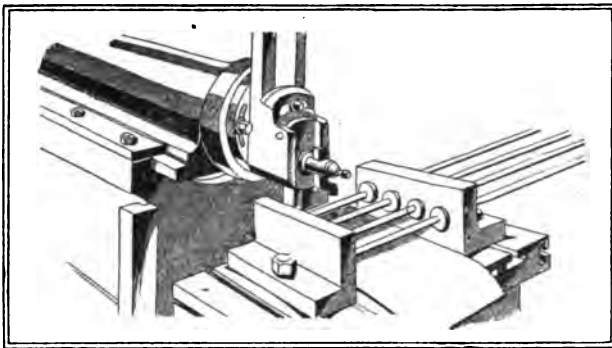

A NUMBER OF WAYS TO CUT PINS IN QUANTITIES

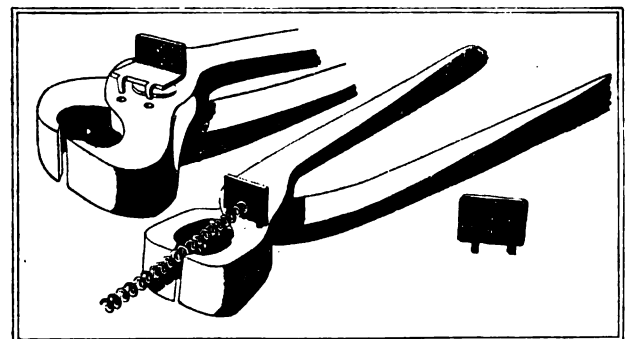
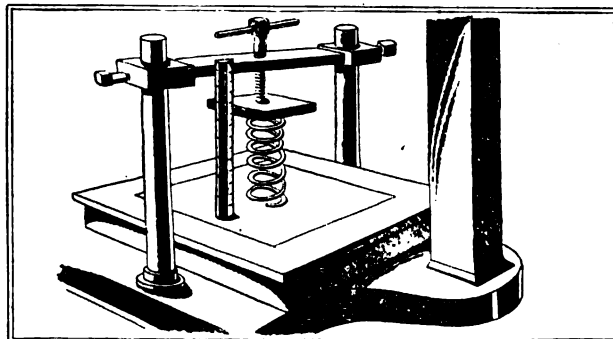
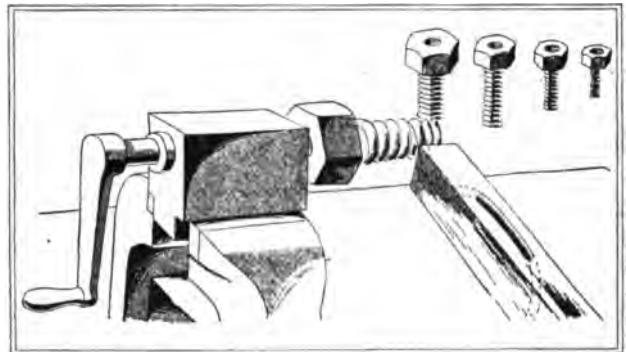
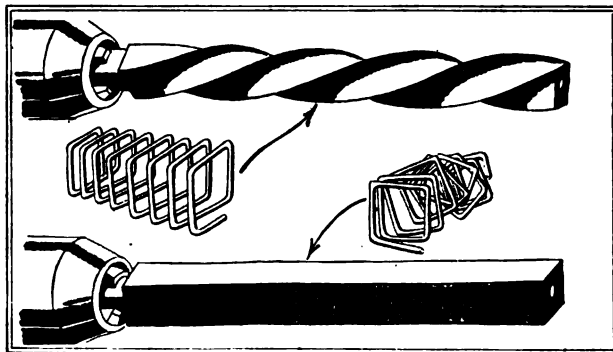
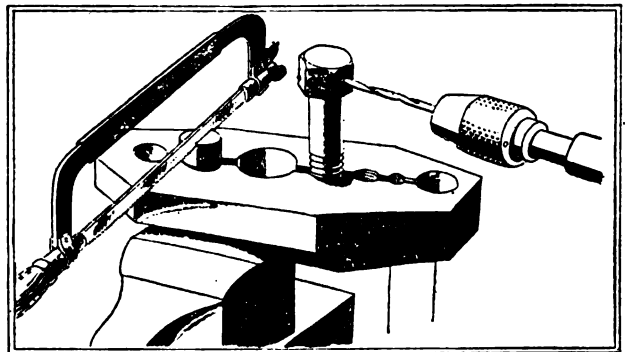
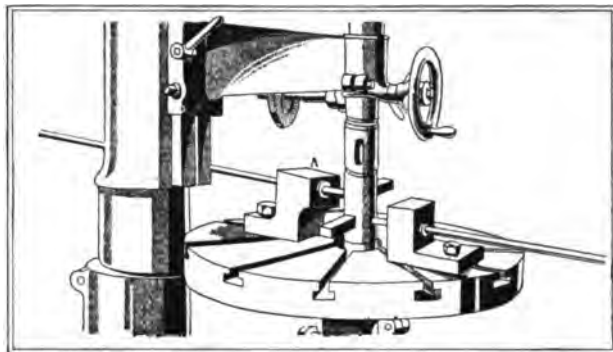
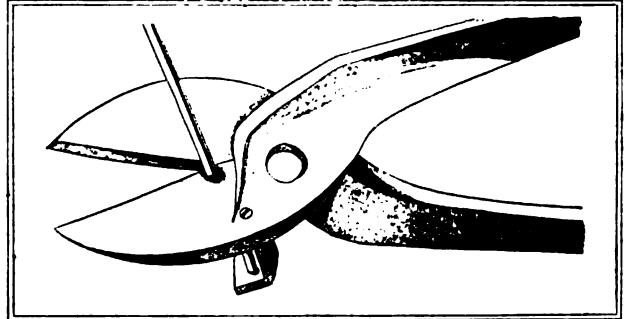
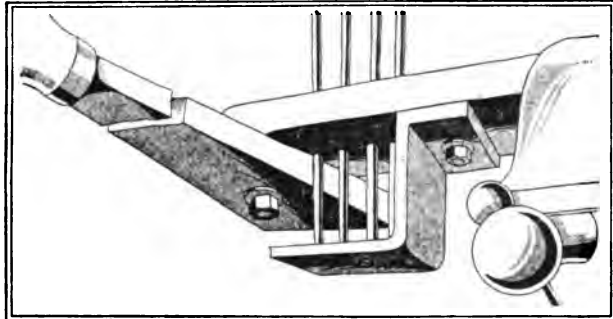
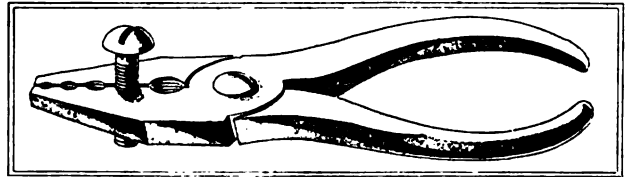
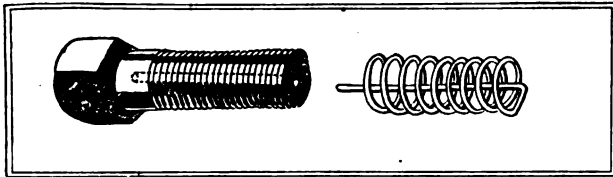

SPRING WINDING, TOOLING, AND CUTTING AND OTHER KINKS

# From a Small-Shop Notebook

By JOHN H. VAN DEVENTER

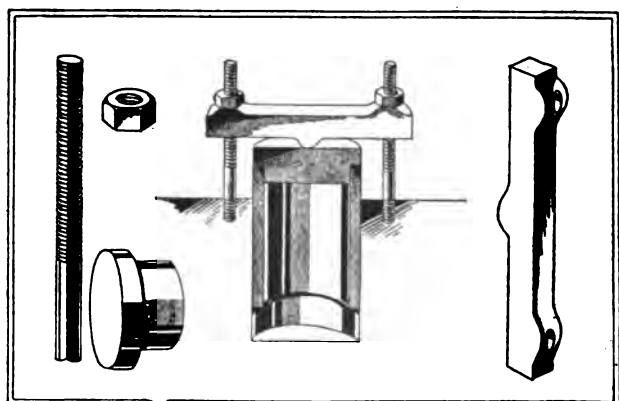
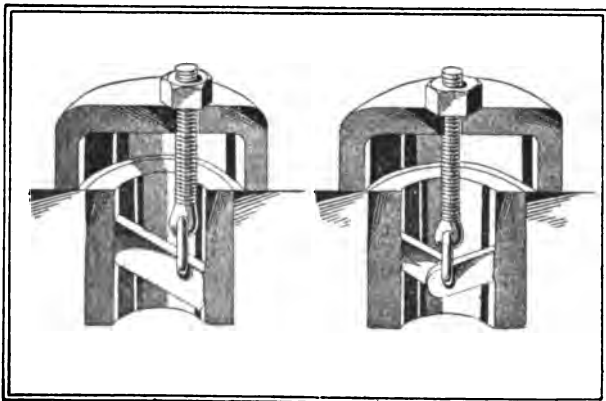
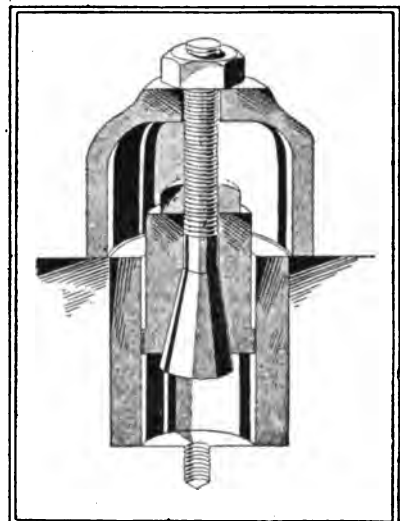
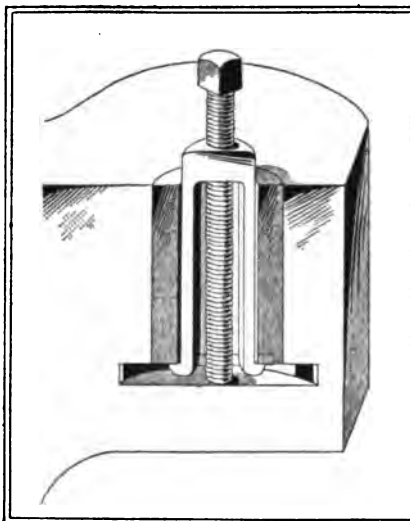
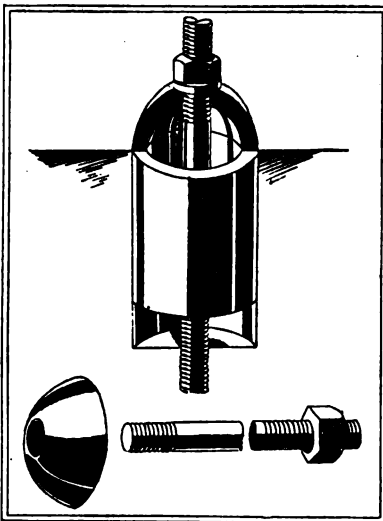
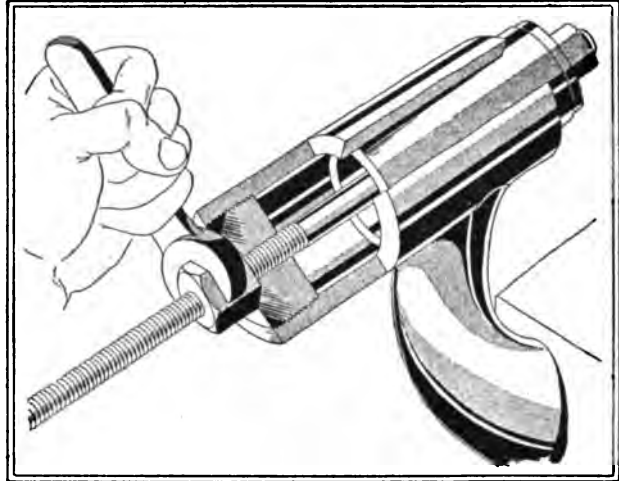
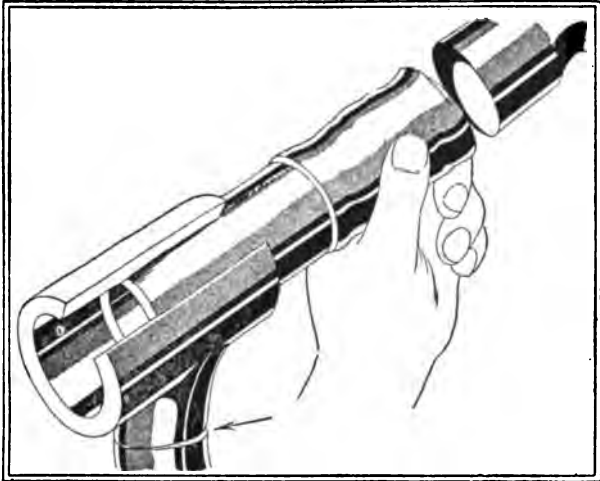

VARIOUS METHODS OF DRIVING AND PULLING BUSHINGS

FROM A SMALL-SHOP NOTEBOOK

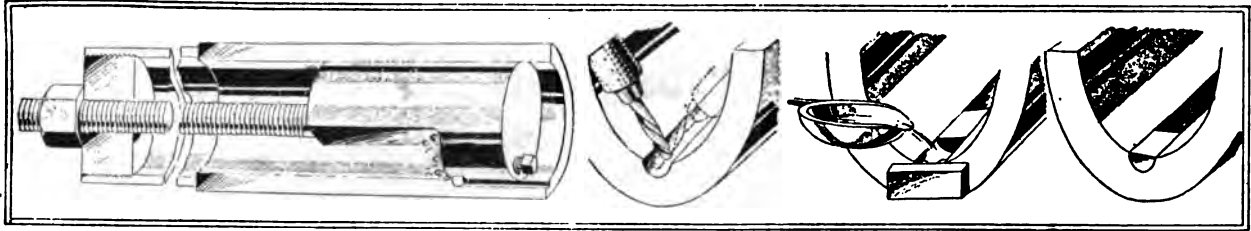

CUTTING A LONG OIL GROOVE

PLUGGING THE ENDS OF THE OIL GROOVE

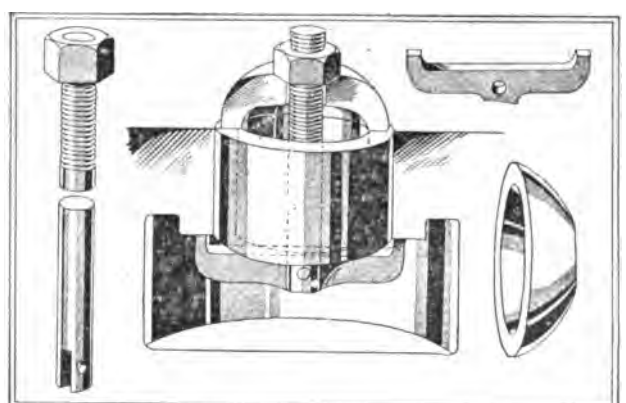
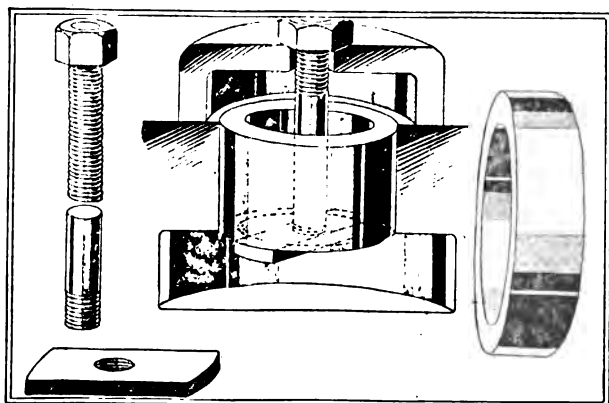
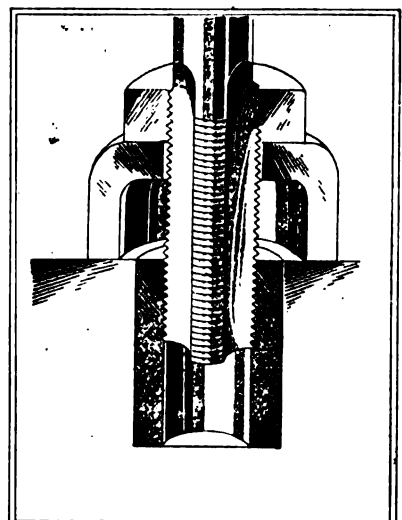
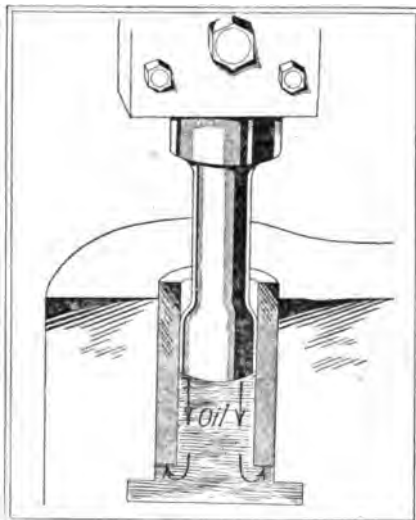
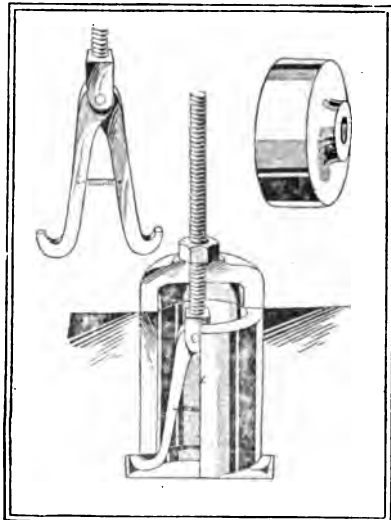
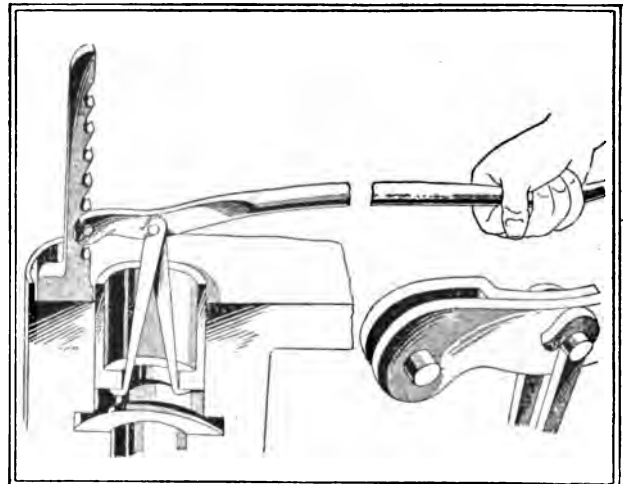
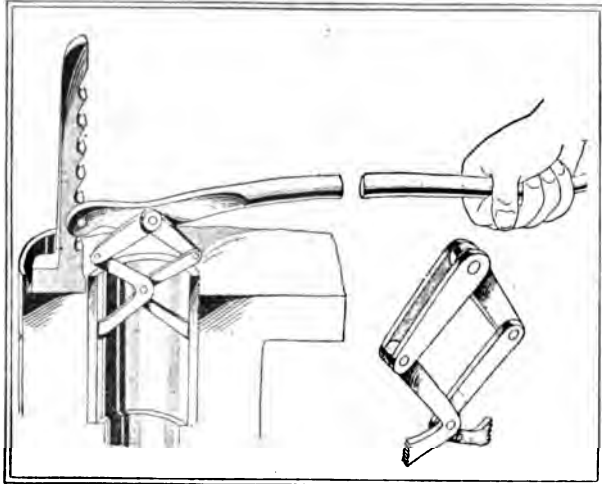

VARIOUS METHODS OF PULLING BUSHINGS

# From a Small-Shop Notebook

By JOHN H. VAN DEVENTER

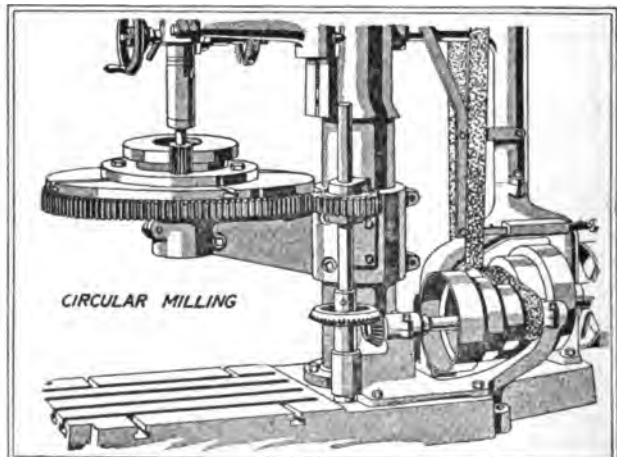
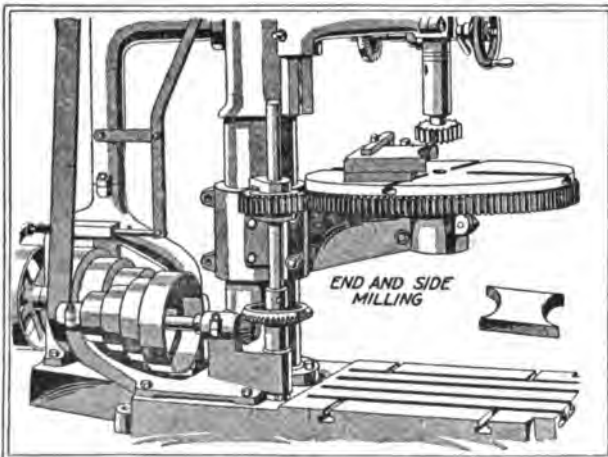
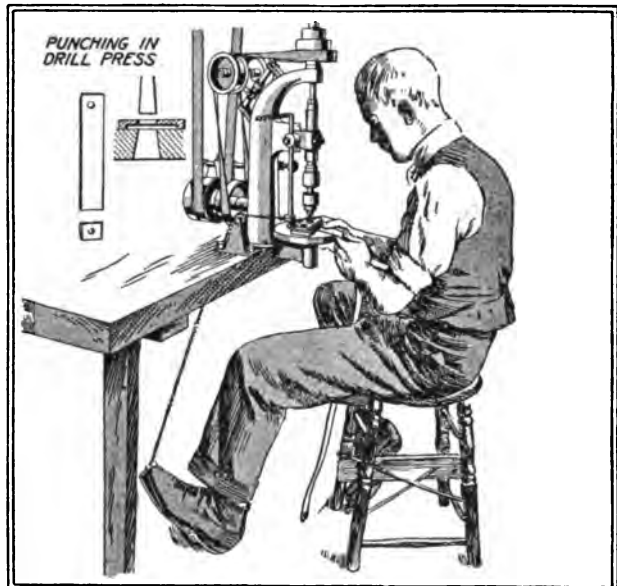
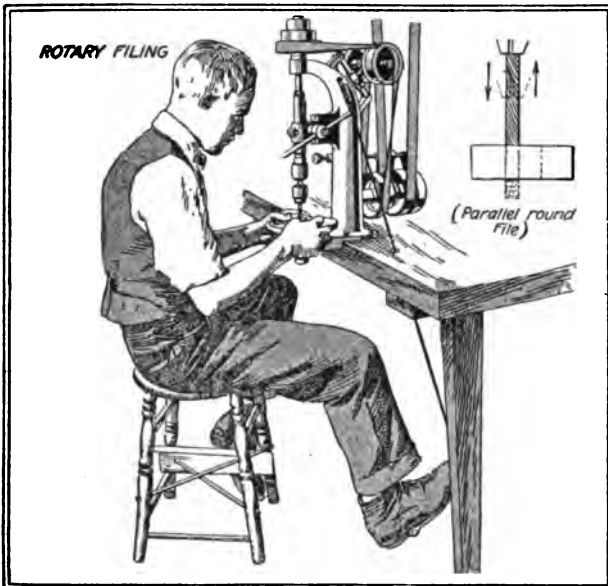
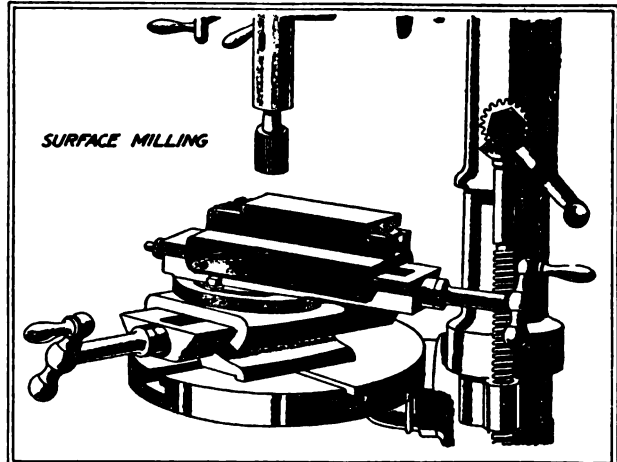
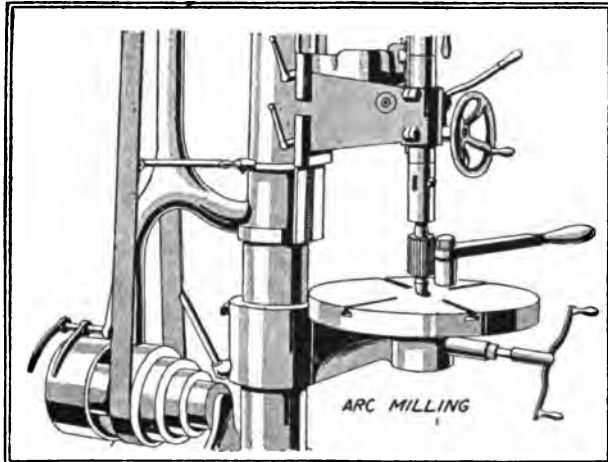

MAKING THE DRILLING MACHINE EARN DIVIDENDS

FROM A SMALL-SHOP NOTEBOOK

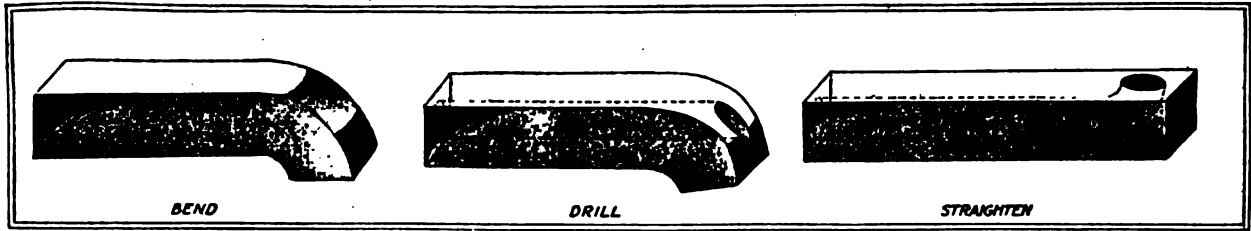

DRILLING A CURVED HOLE

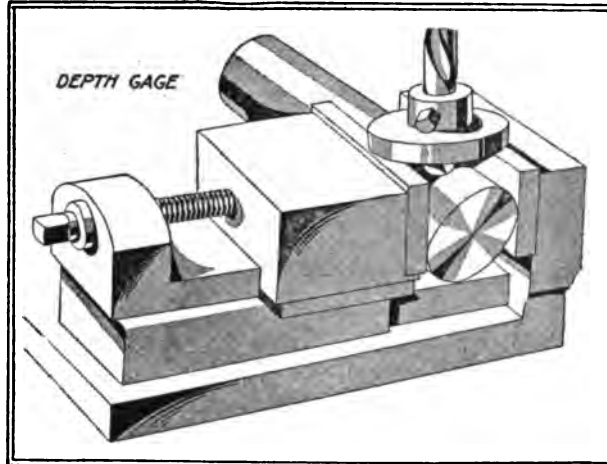

DEPTH GAGE

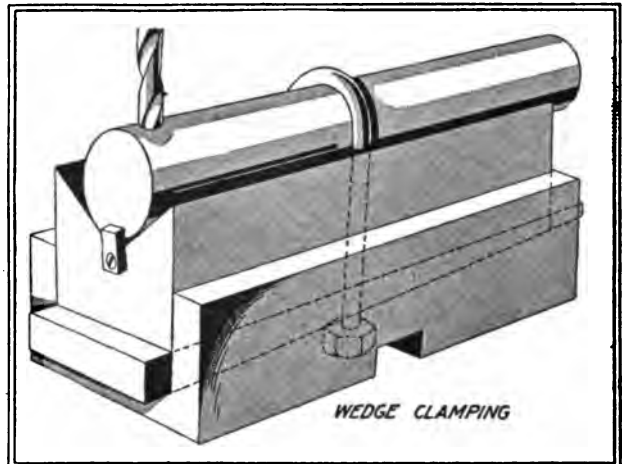

WEDGE CLAMPING

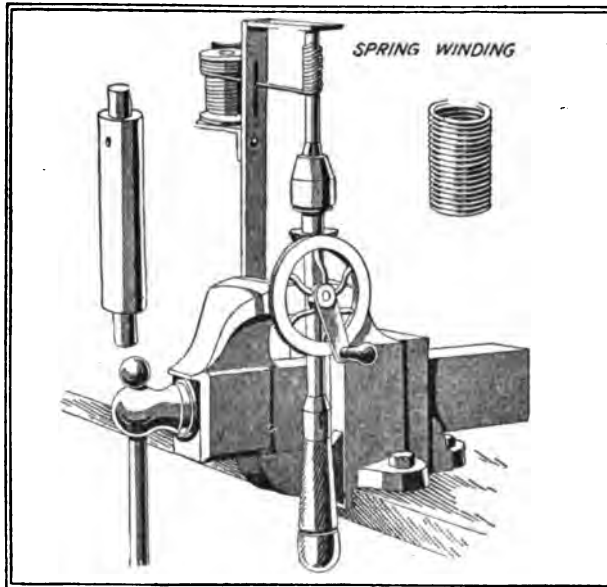

SPRING WINDING

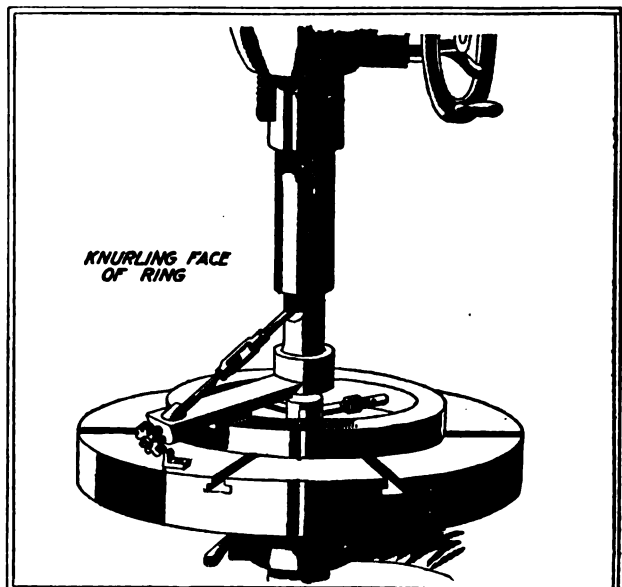

KNURLING FACE OF RING

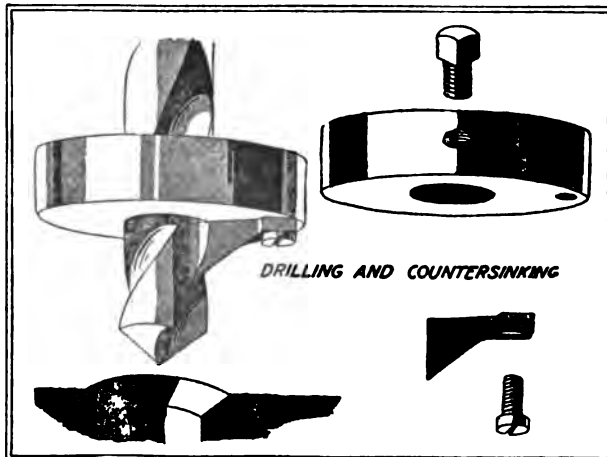

DRILLING AND COUNTERSINKING

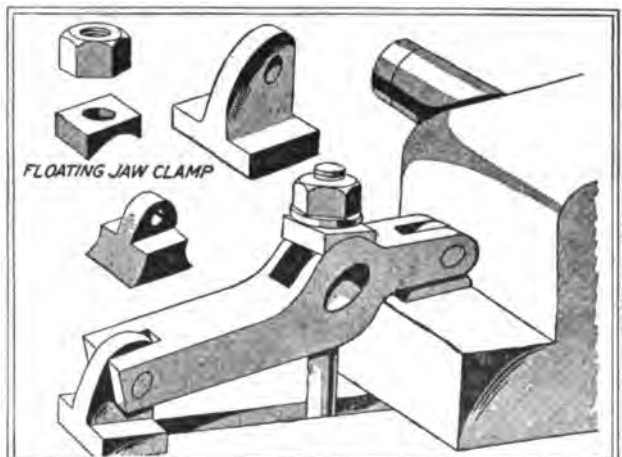

FLOATING JAW CLAMP

BENCH AND VISE KINKS OF SHOP VALUE

# From a Small-Shop Notebook

BY JOHN H. VAN DEVENTER

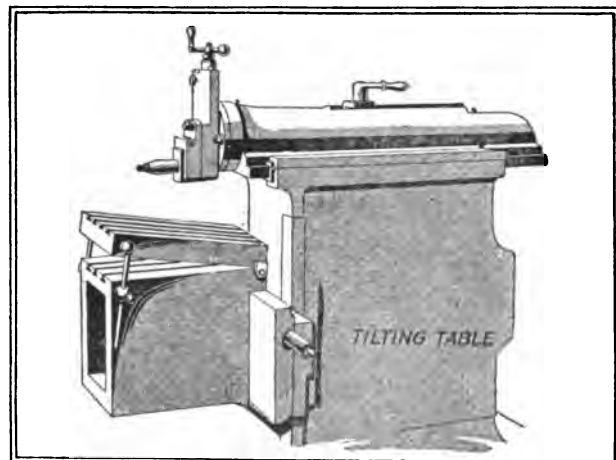
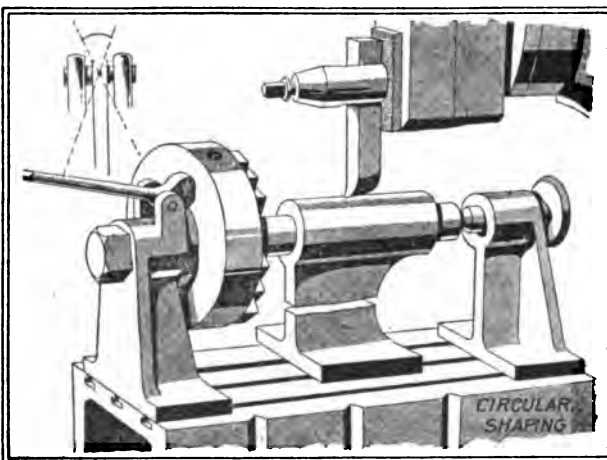
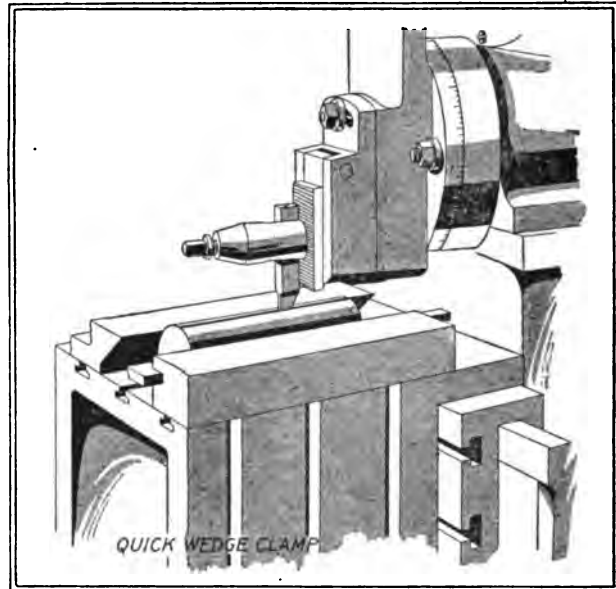
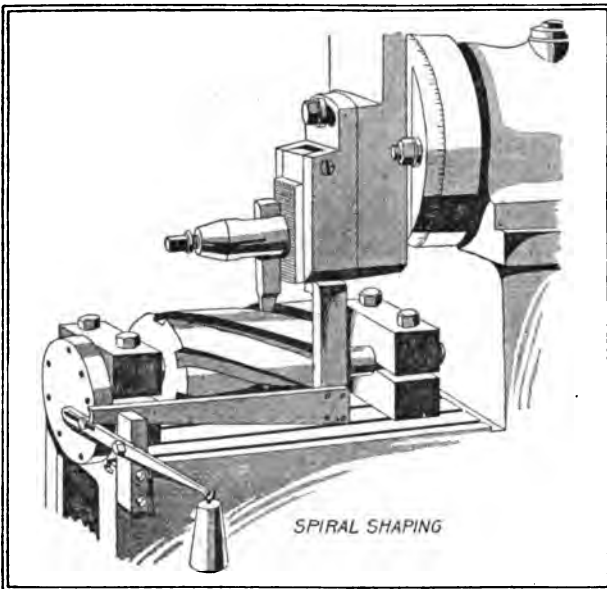
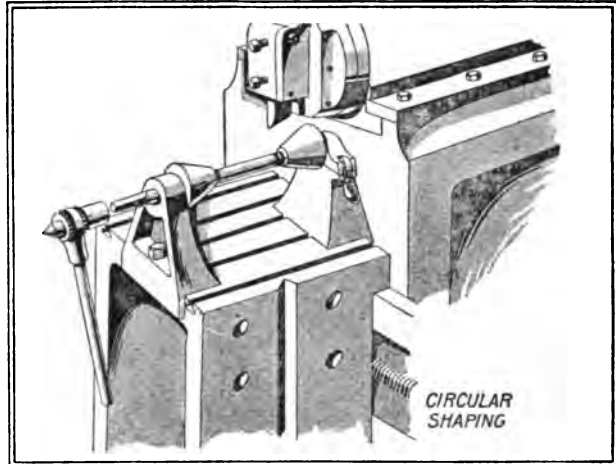
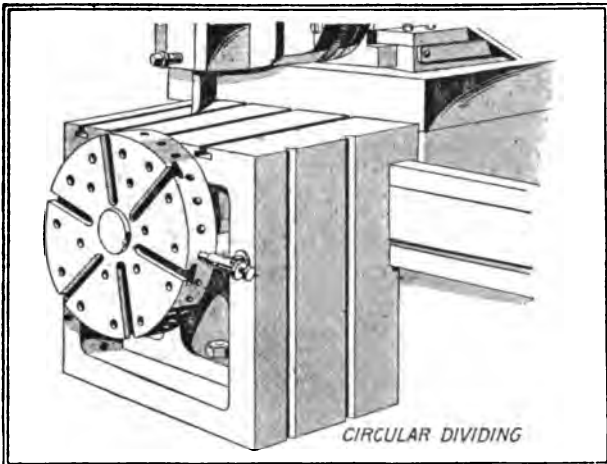

STUNTS THAT MAKE SHAPERS EARN PROFITS AND PAY DIVIDENDS



FROM A SMALL-SHOP NOTEBOOK

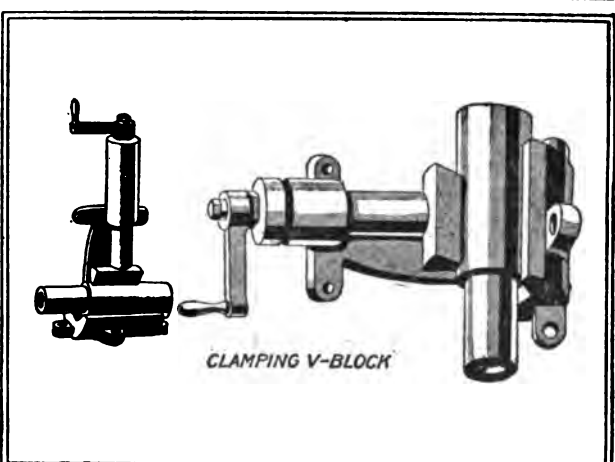
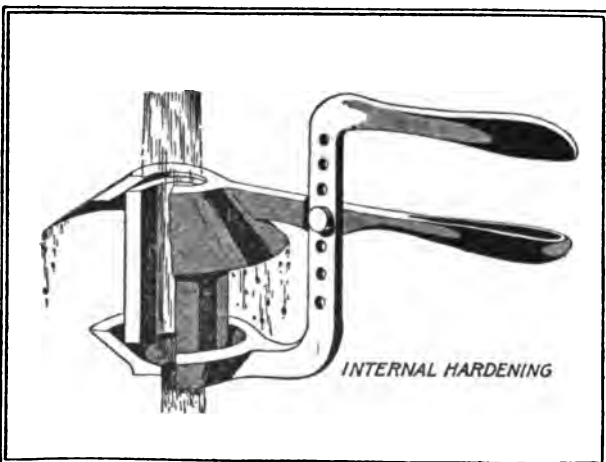
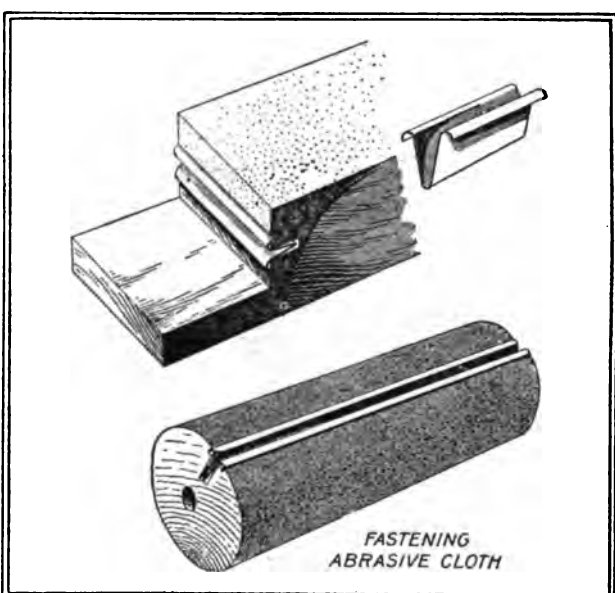
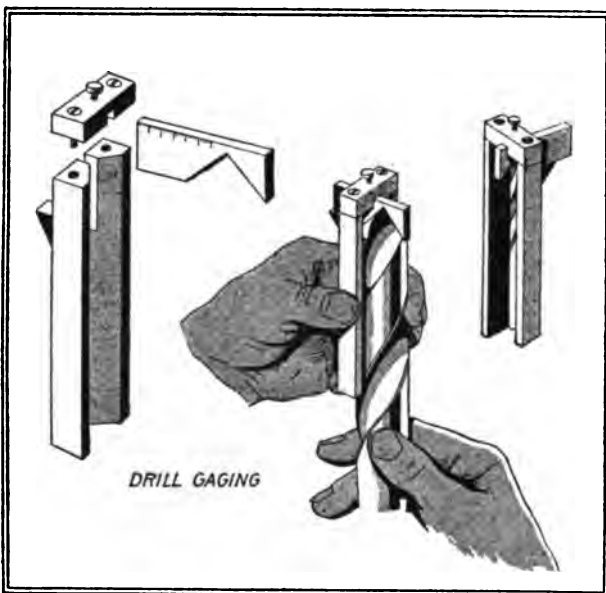
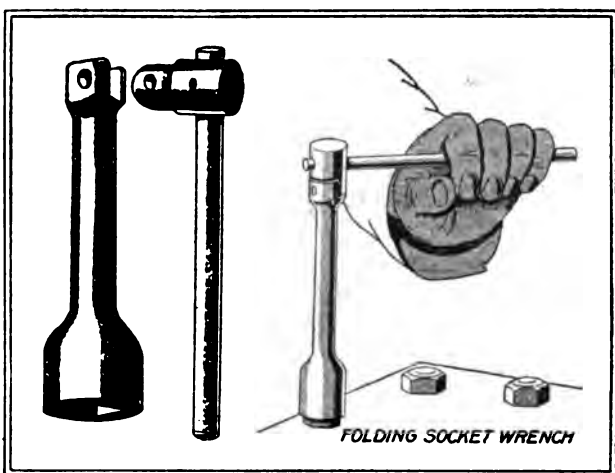
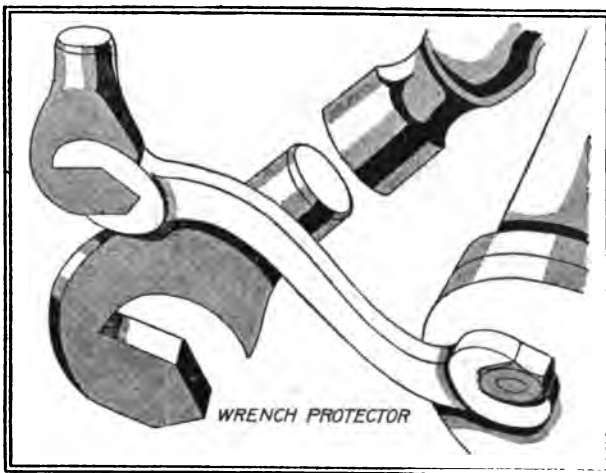
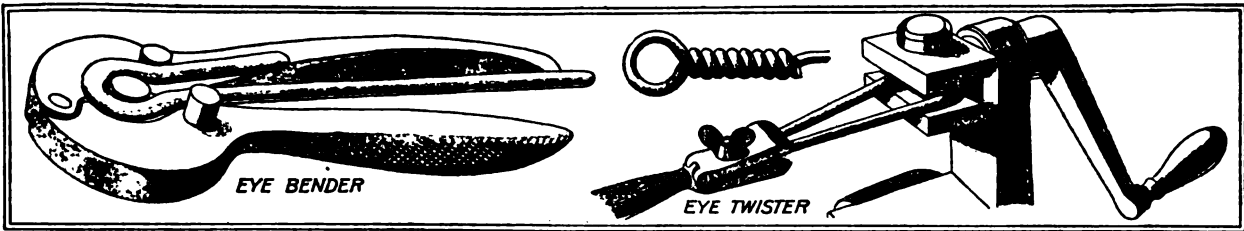

ADD THESE BENCH AND VISE KINKS TO YOUR COLLECTION

# From a Small-Shop Notebook

By JOHN H. VAN DEVENTER

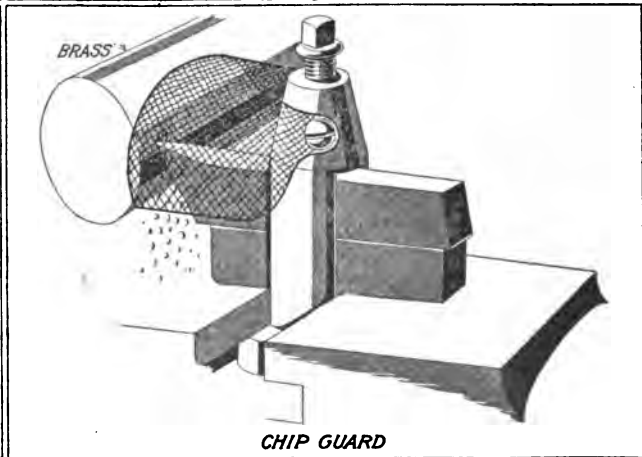
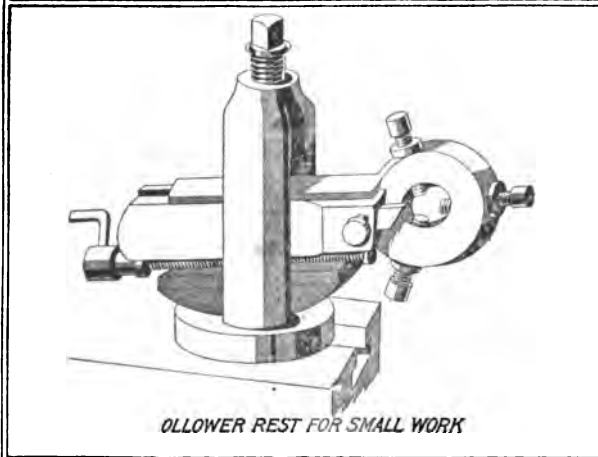
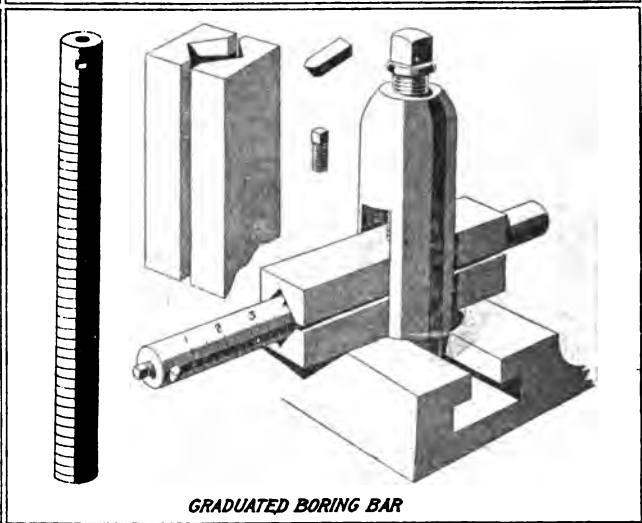
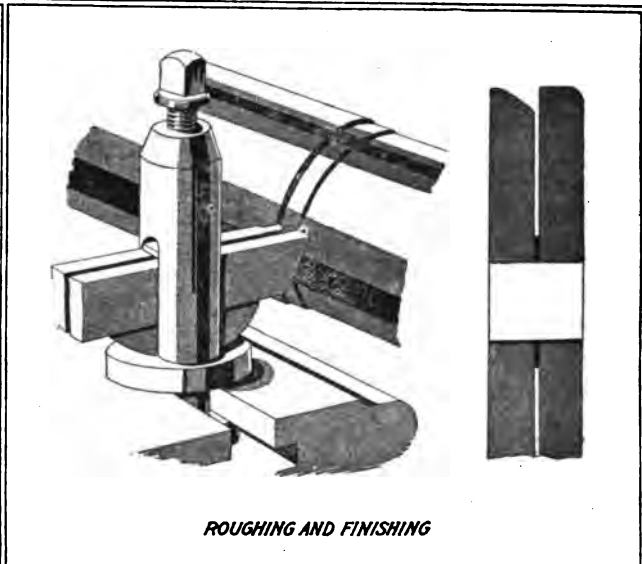
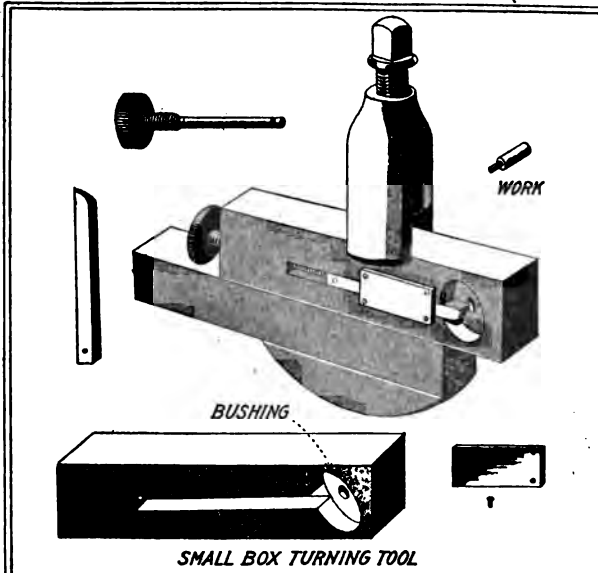

SLIDE-REST KINKS AND CUTTING-TOOL STUNTS

FROM A SMALL-SHOP NOTEBOOK

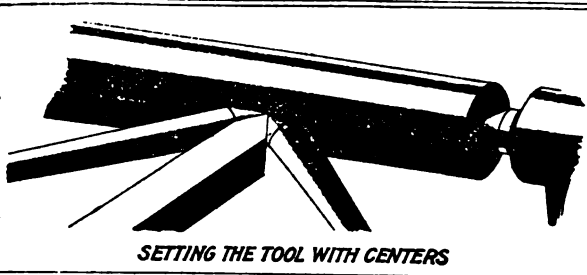

SETTING THE TOOL WITH CENTERS

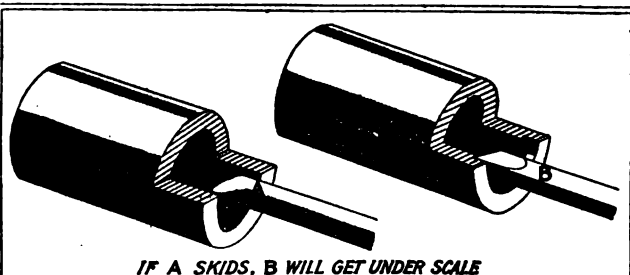

IF A SKIDS, B WILL GET UNDER SCALE

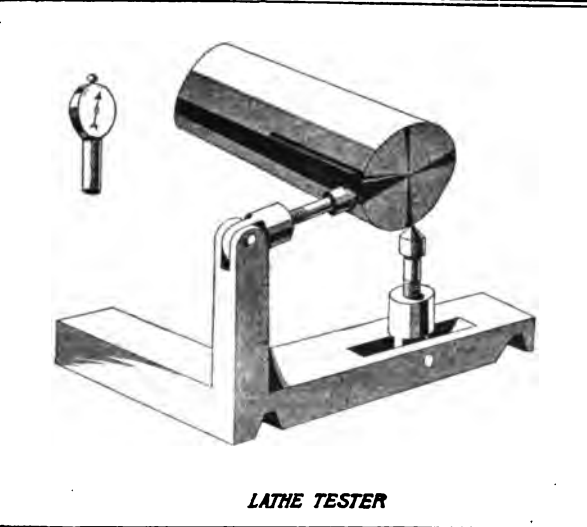

LATHE TESTER

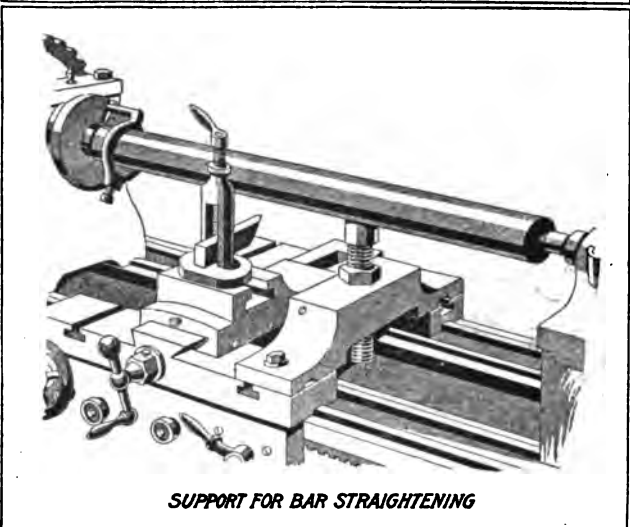

SUPPORT FOR BAR STRAIGHTENING

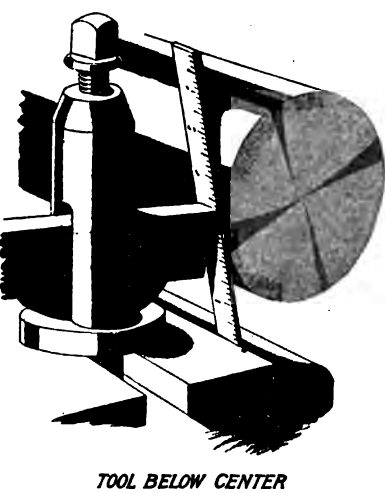

TOOL BELOW CENTER

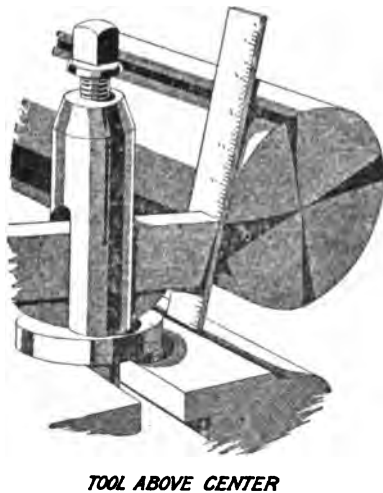

TOOL ABOVE CENTER

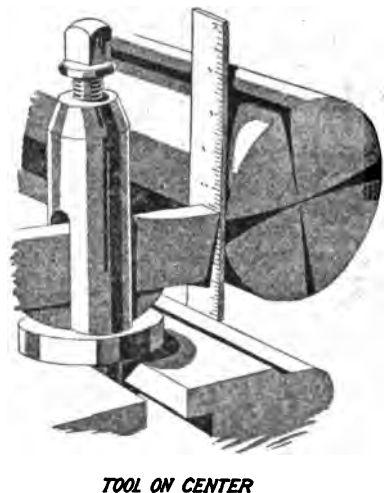

TOOL ON CENTER

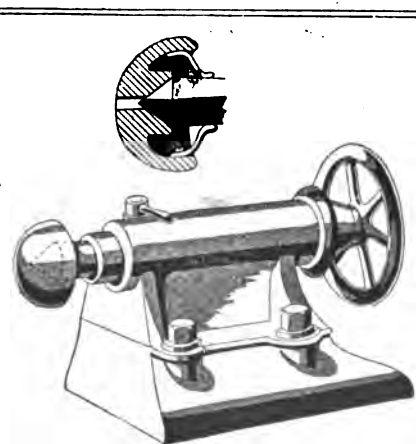
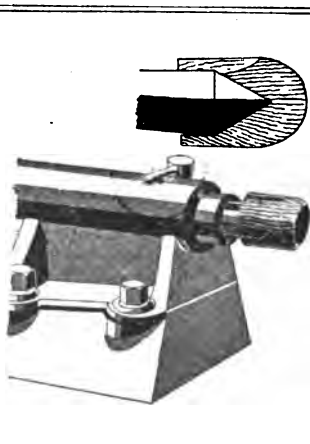

CENTER PROTECTORS

HINTS THAT WILL HELP THE AMBITIOUS LATHE HAND

# From a Small-Shop Notebook

By J. A. LUCAS

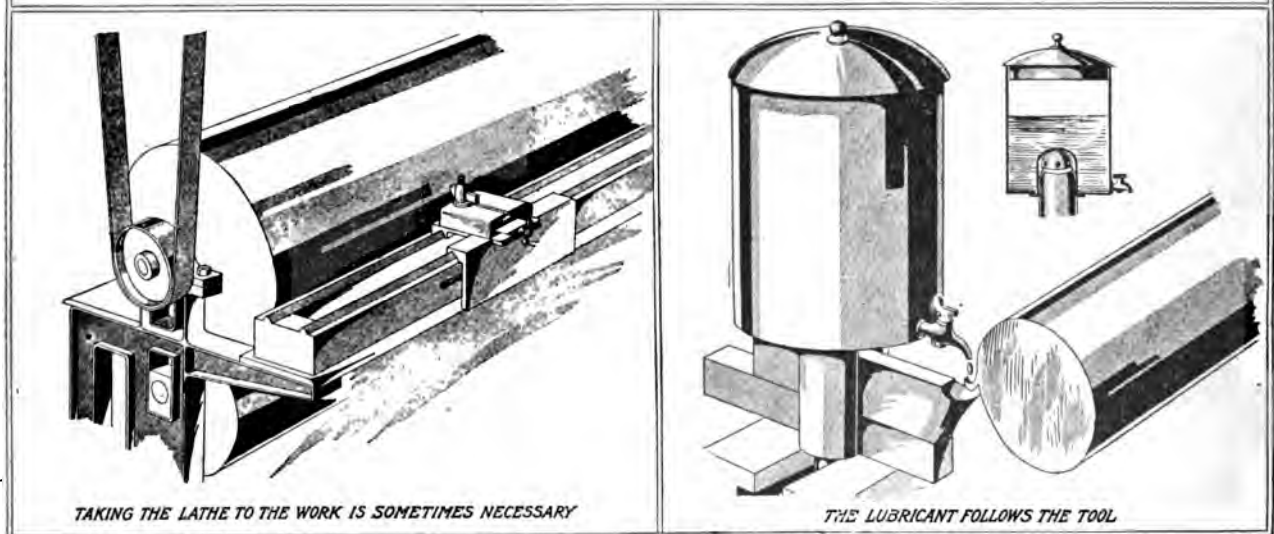
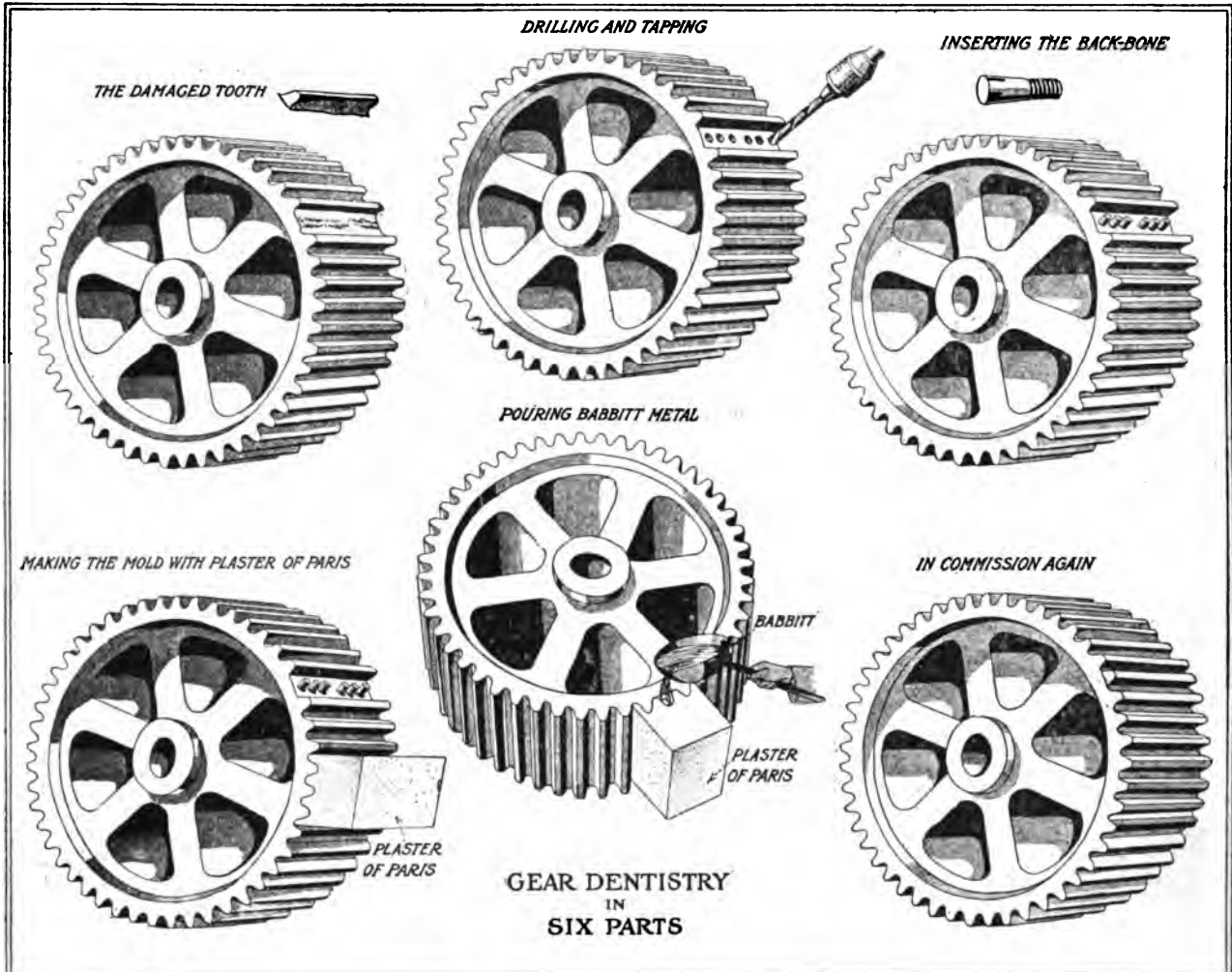

TAKEN FROM ACTUAL PRACTICE

FROM A SMALL-SHOP NOTEBOOK

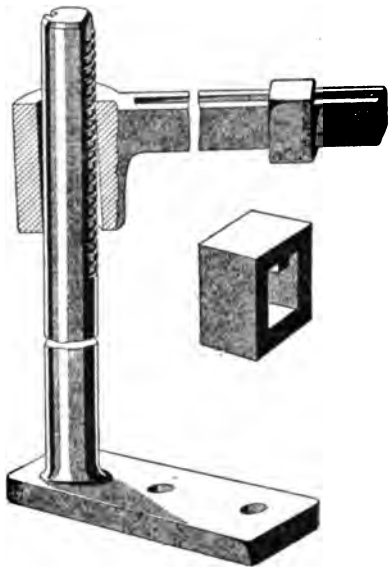

RATCHET GRIP

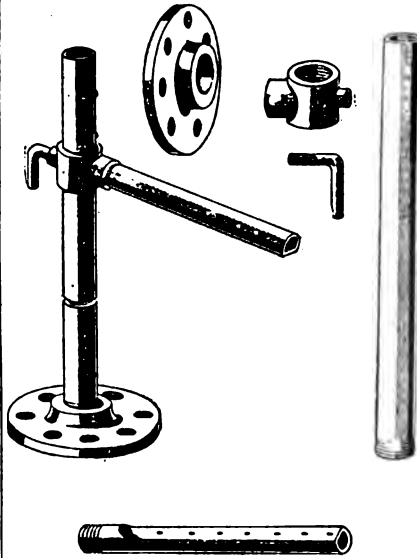

MADE OF PIPE AND FITTINGS

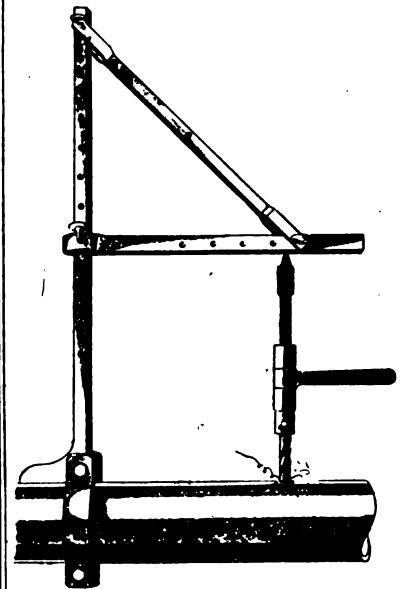

FOR PIPE OR SHAFTS

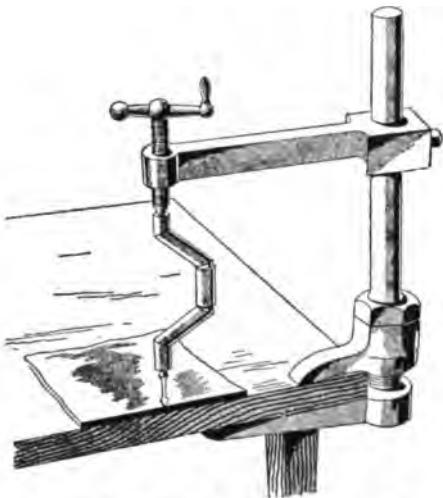

REQUIRES LITTLE SPACE AND DOES MUCH WORK

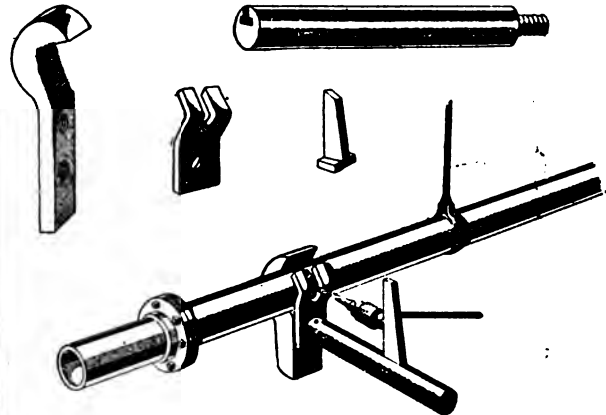

PERFORMS WONDERS ON BOARD SHIP

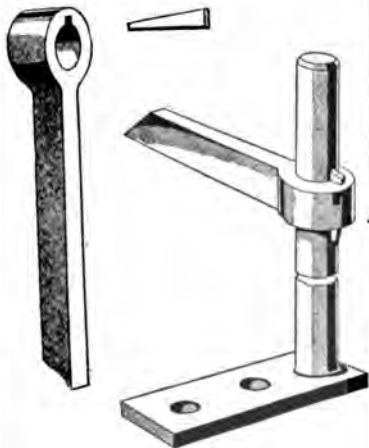

WEDGE GRIP

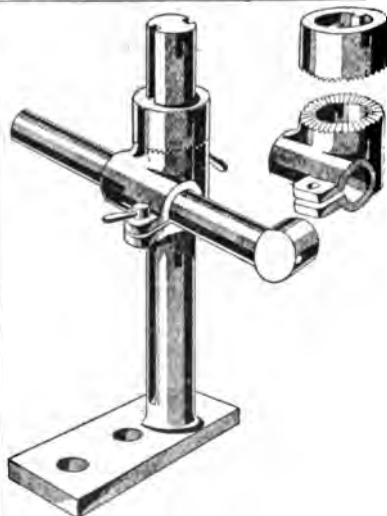

UNIVERSAL "OLD MAN"

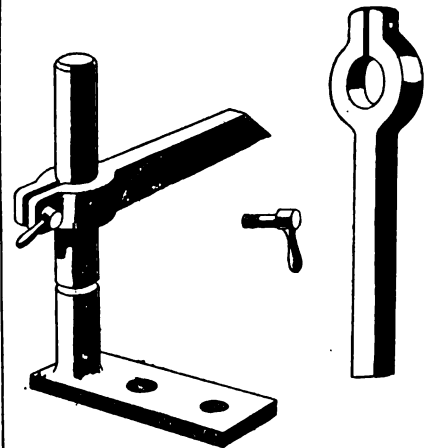

CLAMP GRIP

SEVEN APPLICATIONS OF "OLD MEN"

# From a Small-Shop Notebook

By J. A. LUCAS

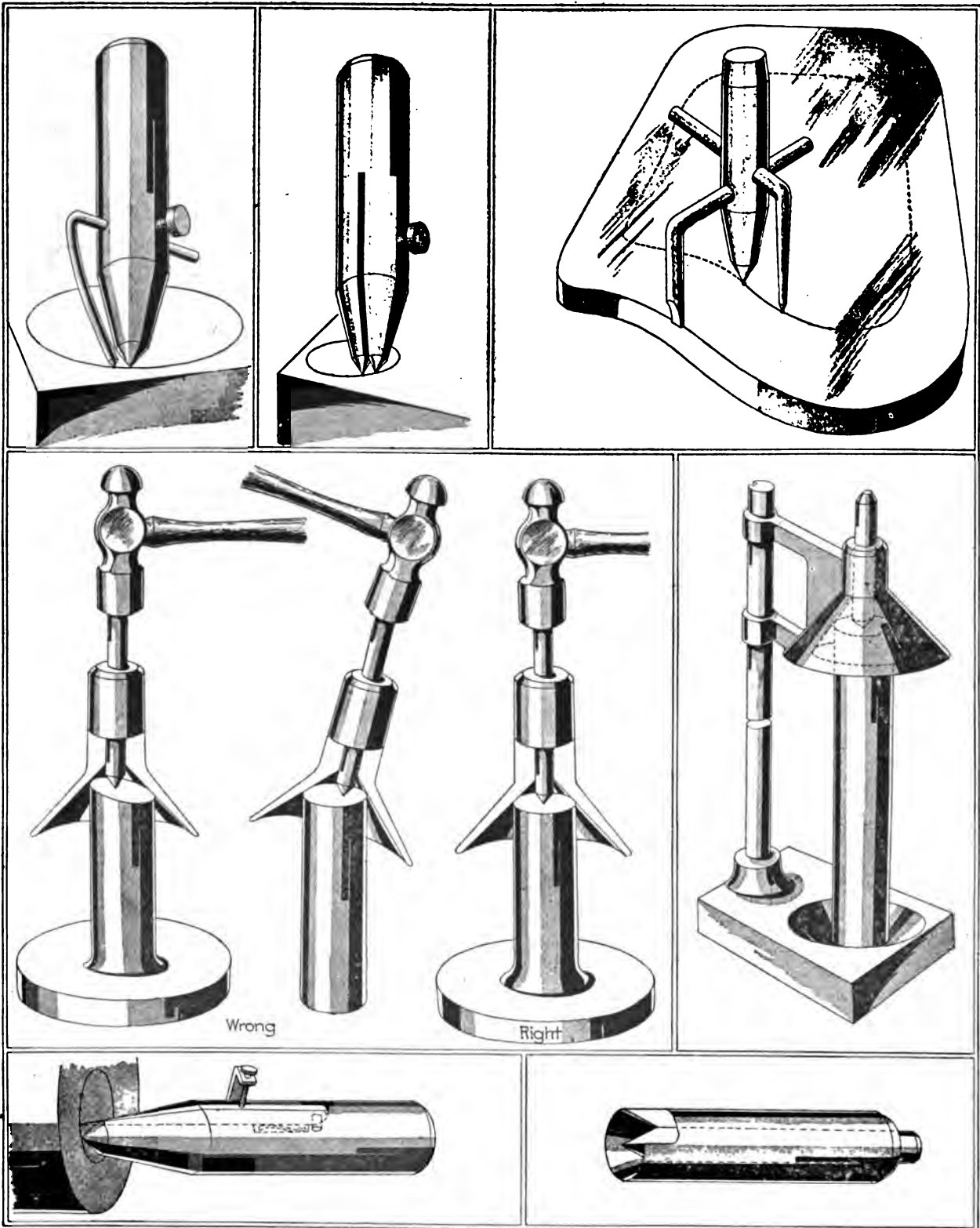

VARIOUS CENTERPUNCHING KINKS

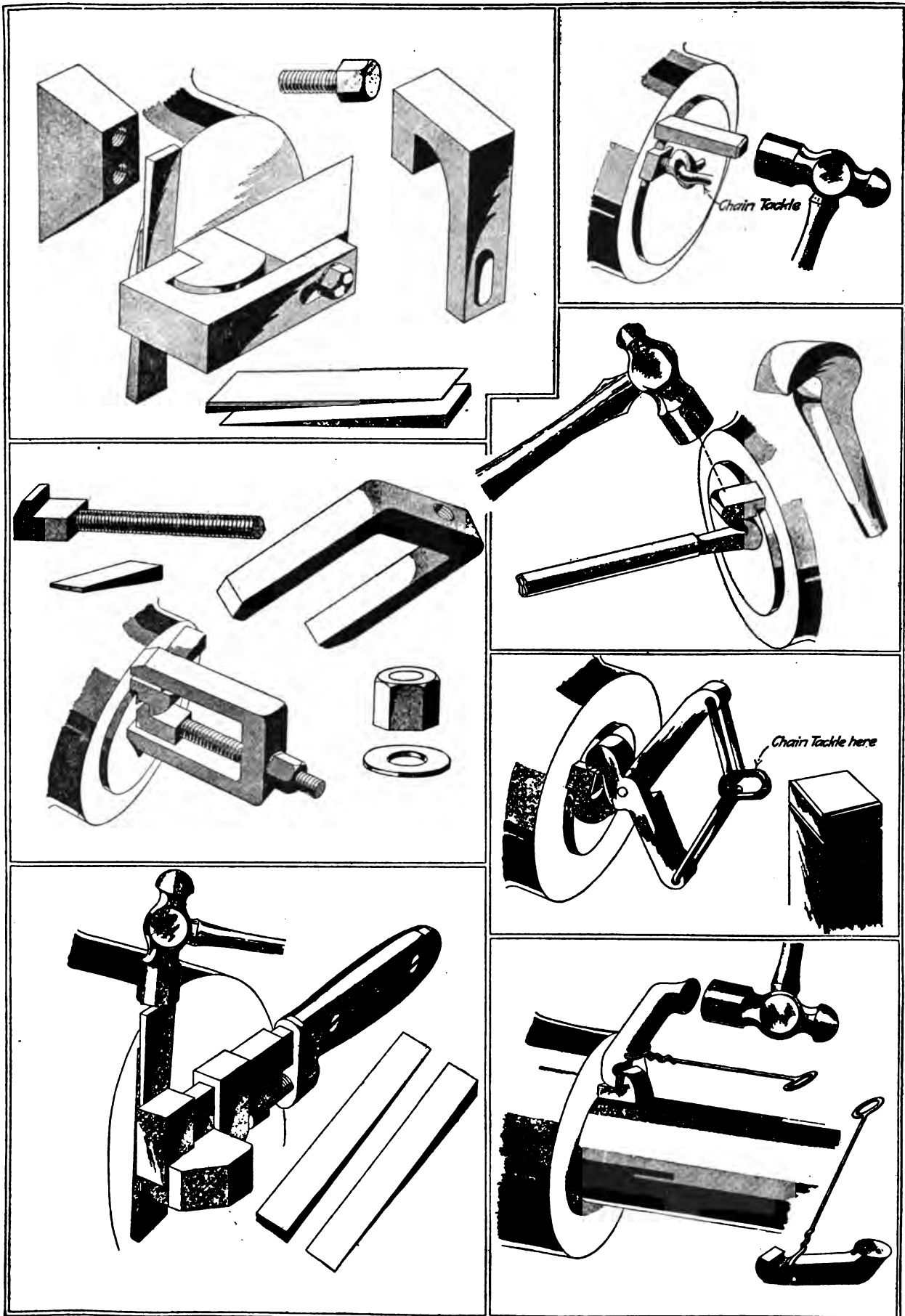

VARIOUS WAYS OF PULLING KEYS

# From a Small-Shop Notebook

By J. A. LUCAS

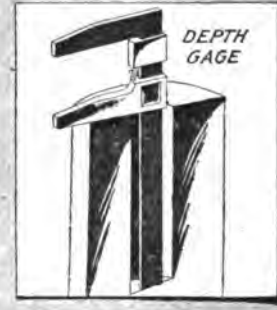
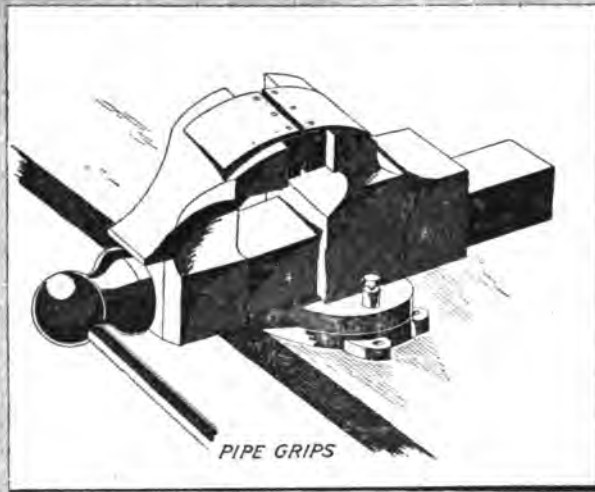
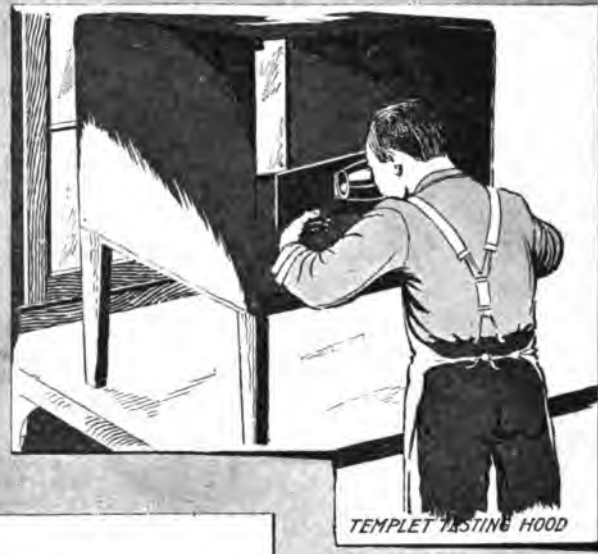
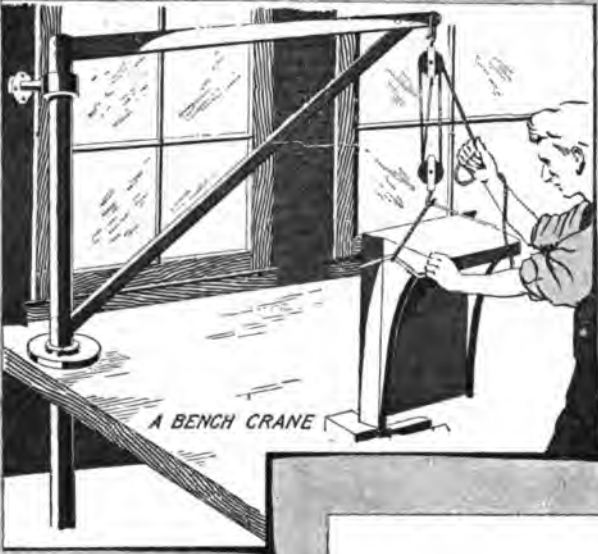

A NUMBER OF HANDY SHOP KINKS





AS A PUNCH PRESS

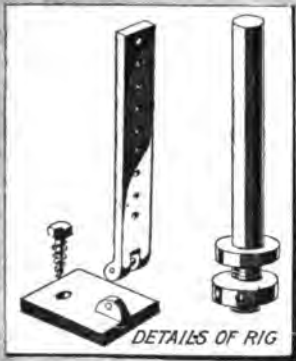

DETAILS OF RIG

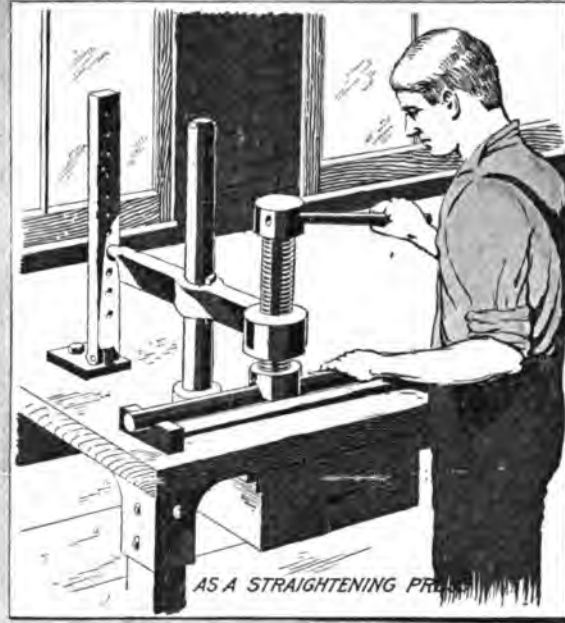

AS A STRAIGHTENING PRESS



DETAILS OF RIG

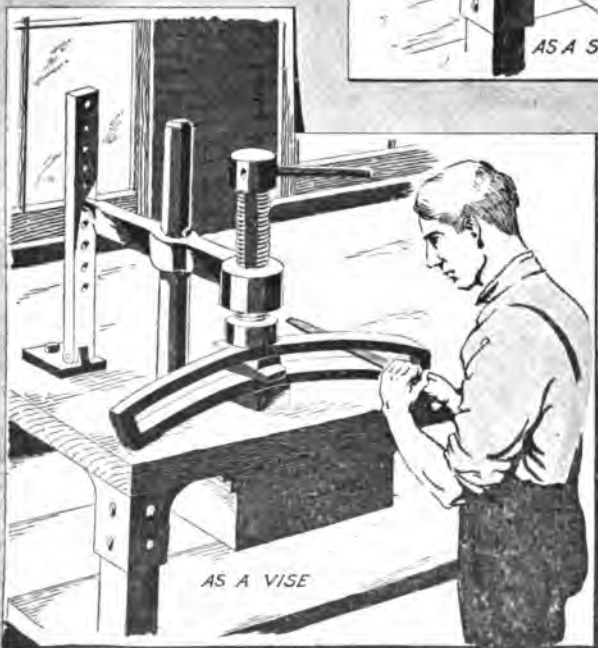

AS A VISE



DRIVING BUSHINGS

# From a Small-Shop Notebook

By J. A. LUCAS

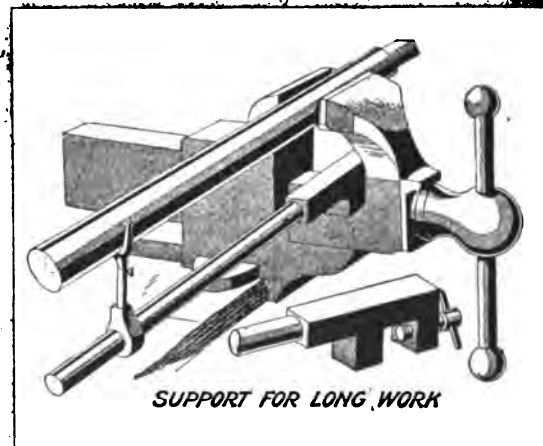
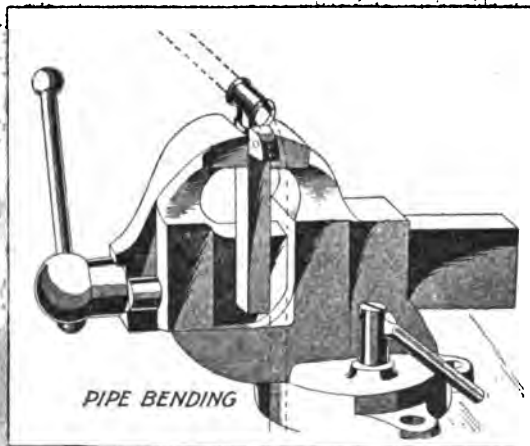
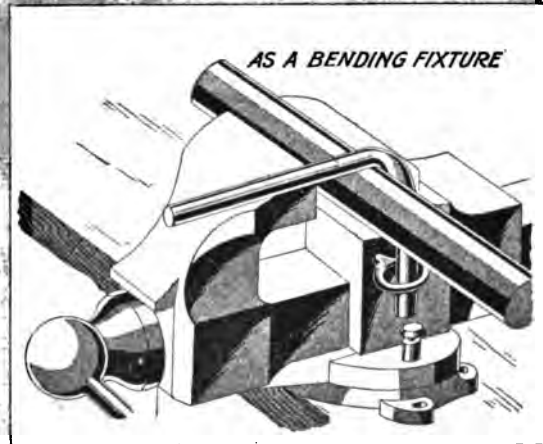
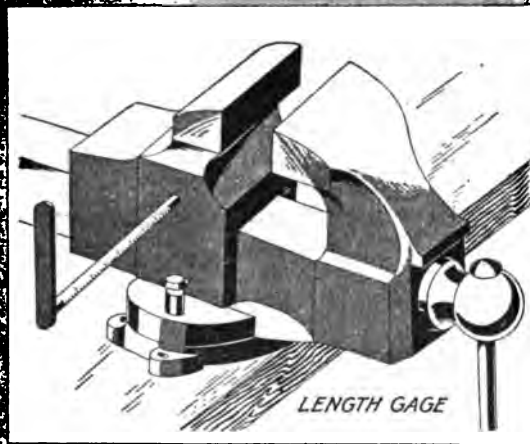
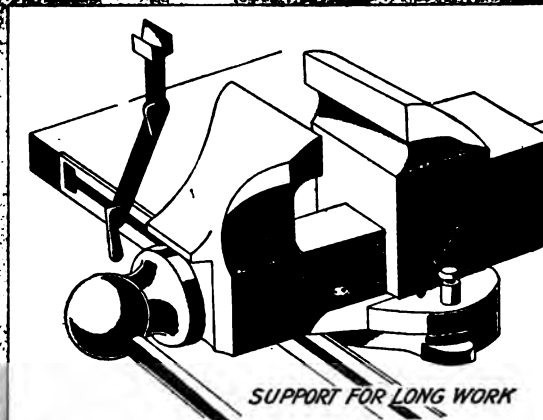
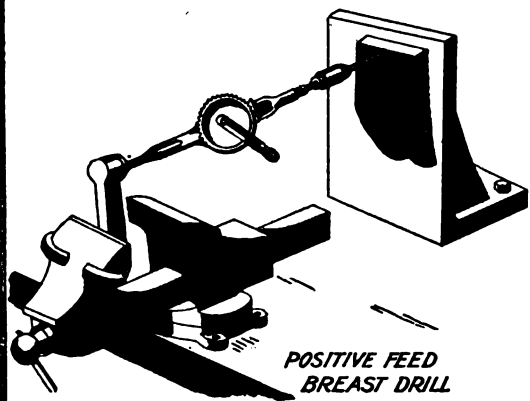

A NUMBER OF HANDY VISE KINKS

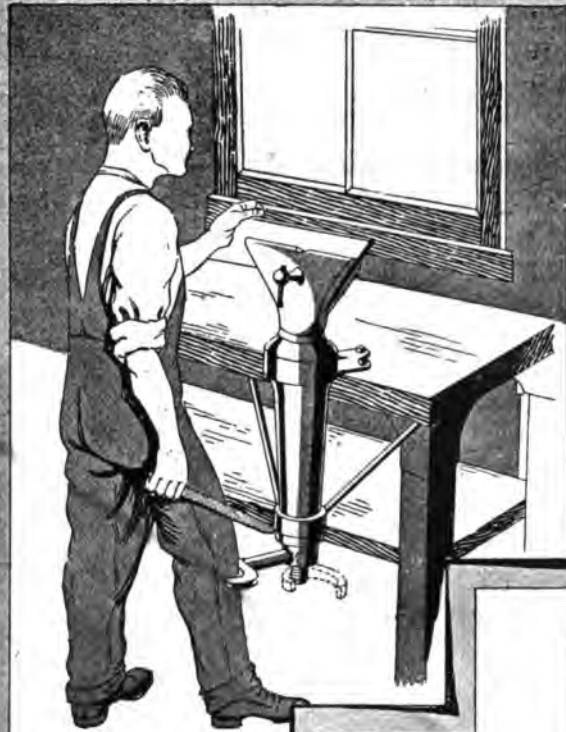

*KNEE-OPERATED VISE*

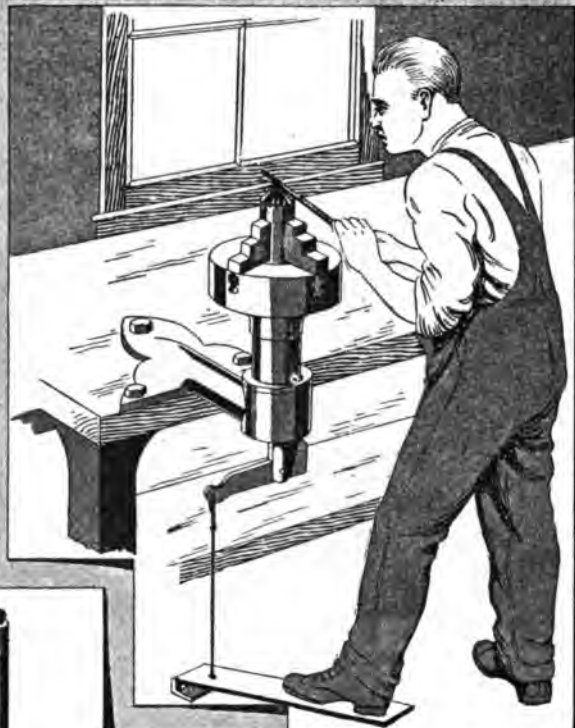

*FOOT-CONTROLLED INDEXING*

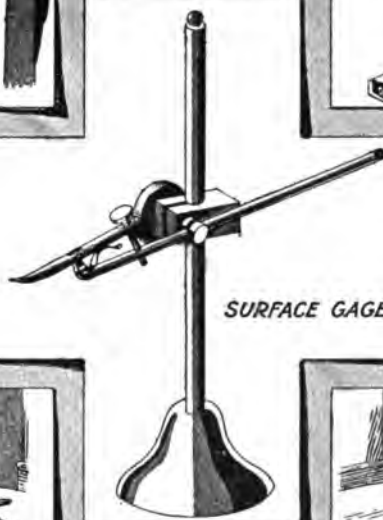

*SURFACE GAGE*



*FOOT-OPERATED SPRING CHUCK*



*FOOT-OPERATED CLAMP FOR SHEAR BLADES*

**HANDY WORK-BENCH DEVICES**

# From a Small-Shop Notebook

By J. A. LUCAS

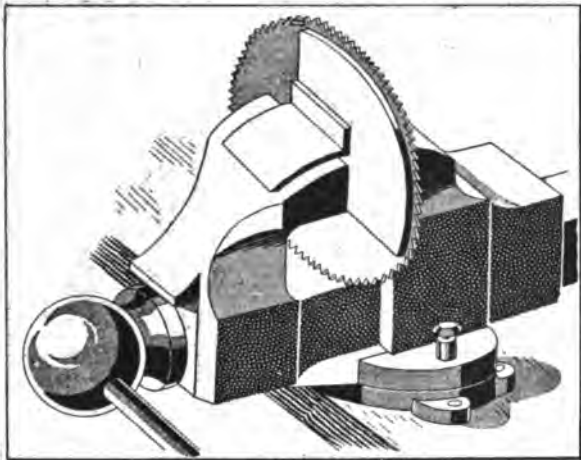

*SAW FILING CLAMP*

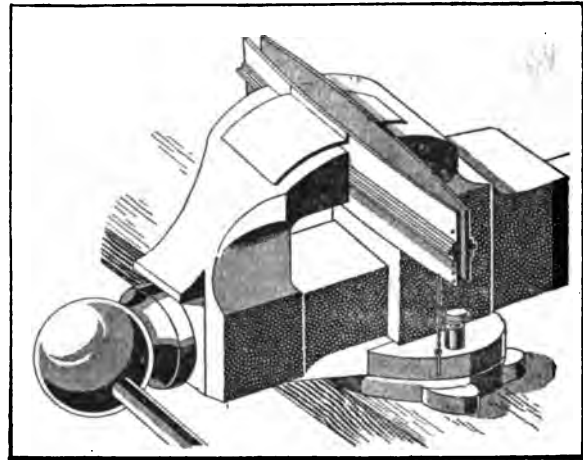

*SHEET METAL FILING CLAMP*

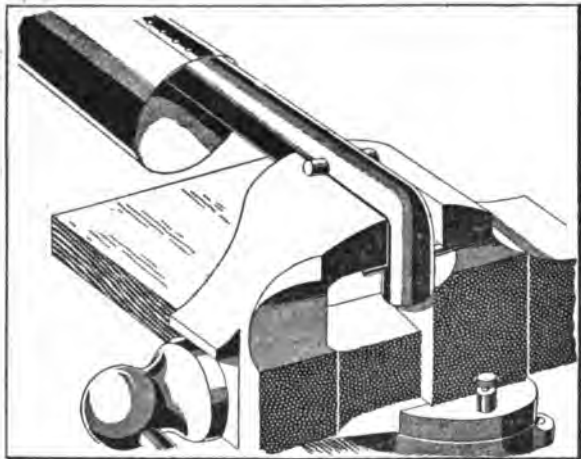

*PIPE RIVETING HORN*

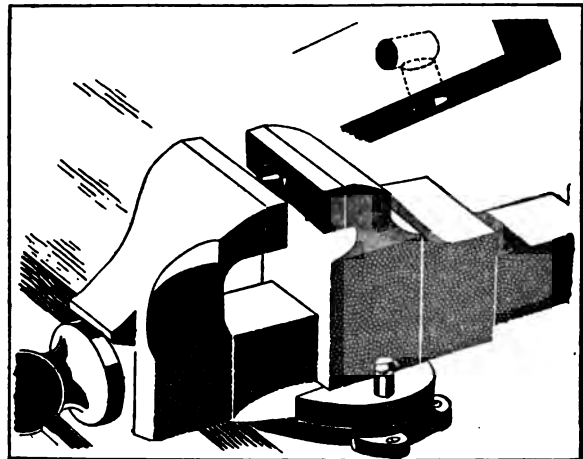

*LIGHT METAL PUNCHING FIXTURE*

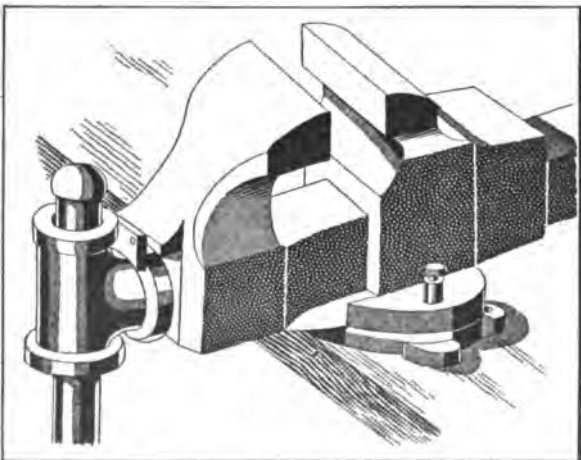

*TEMPORARY SCREW REPAIR*

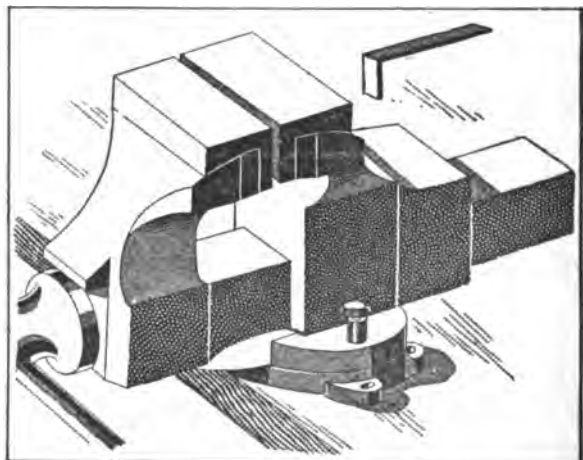

*FALSE JAWS FOR BENDING SHARP ANGLES*

A NUMBER OF HANDY VISE KINKS

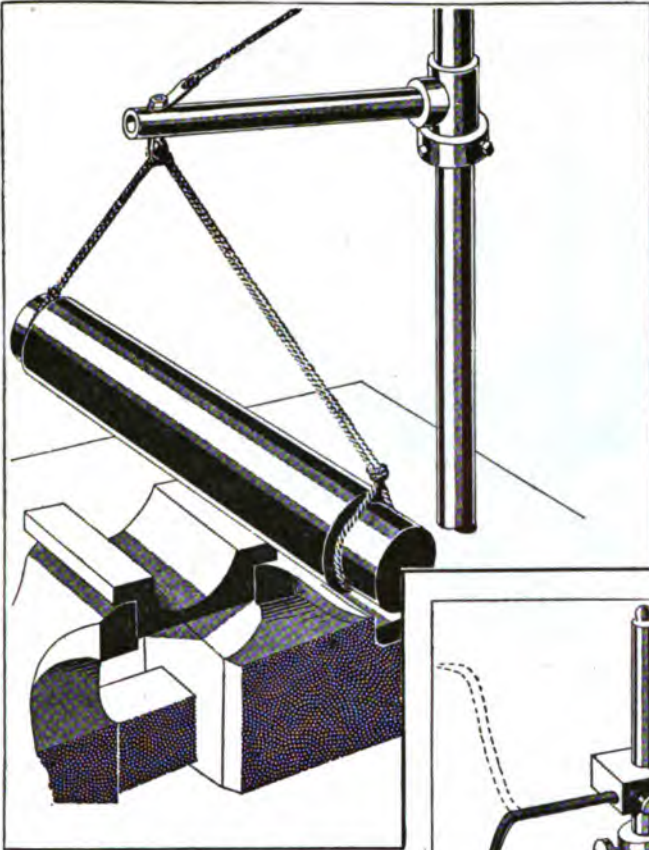

*HANDY BENCH CRANE*

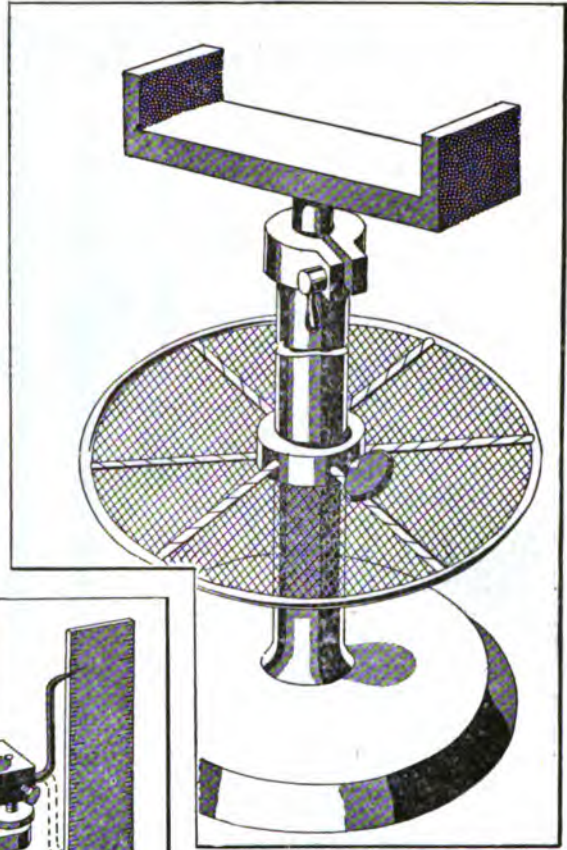

*COMBINED STOCK REST and TOOL SHELF*

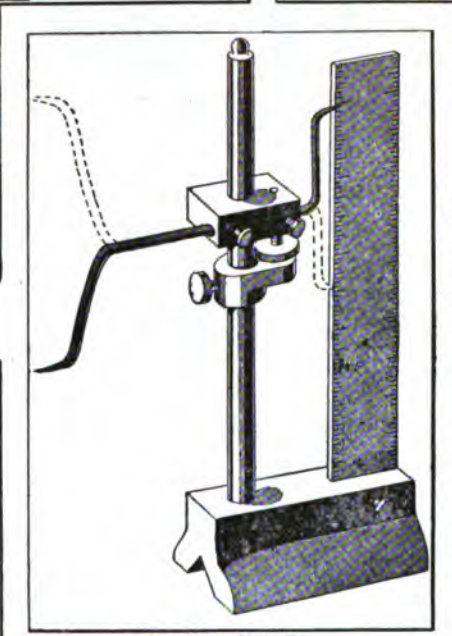

*DOUBLE POINTS*

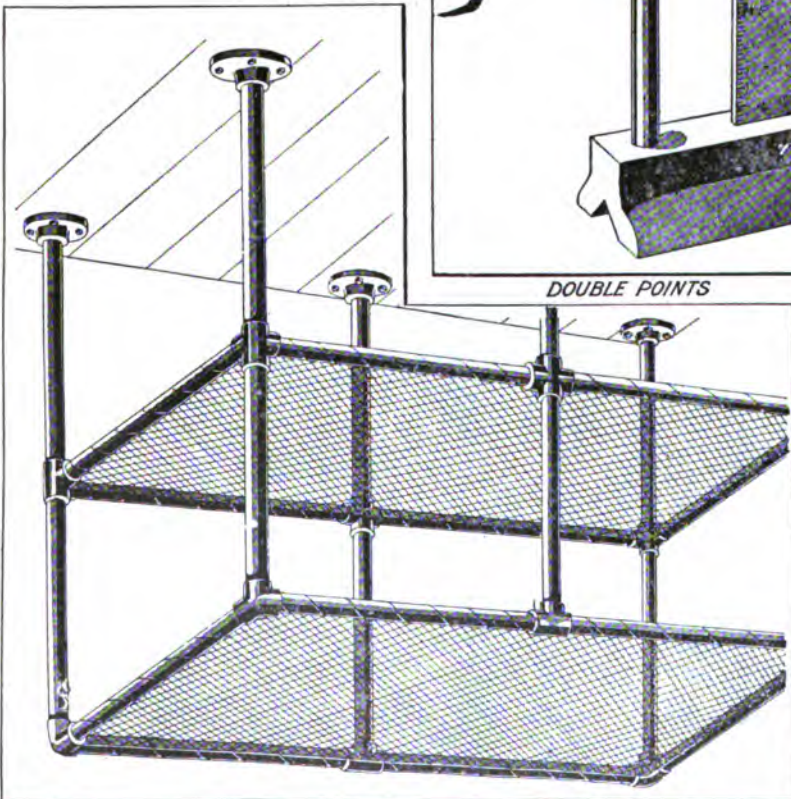

*DUSTLESS SHELVES*

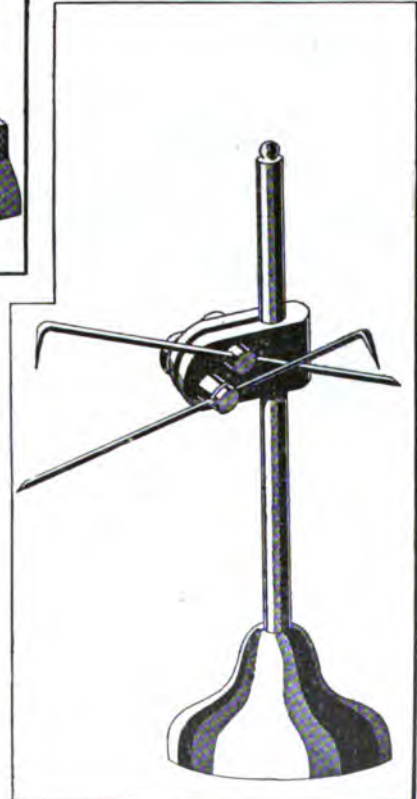

*DOUBLE POINTS*

# From a Small-Shop Notebook

By J. A. LUCAS

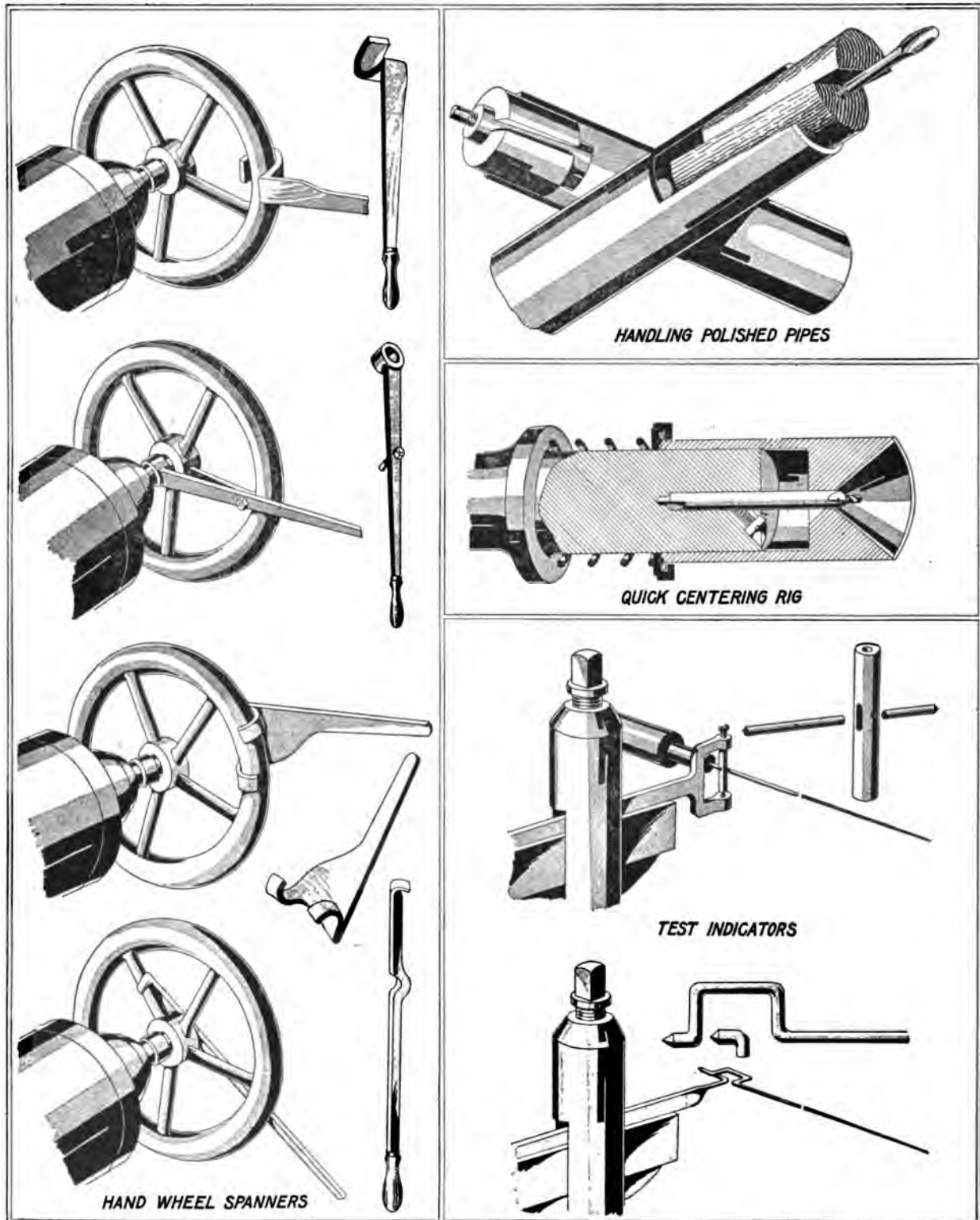

HANDLING POLISHED PIPES

QUICK CENTERING RIG

TEST INDICATORS

HAND WHEEL SPANNERS

SOME USEFUL SHOP KINKS

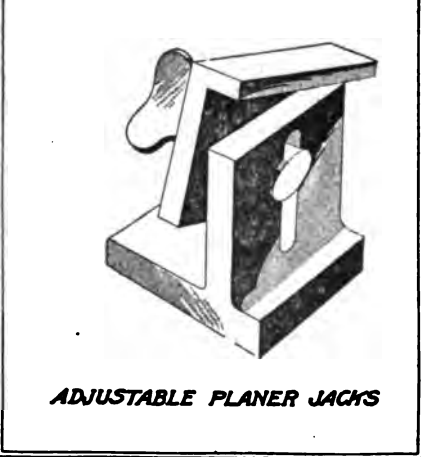
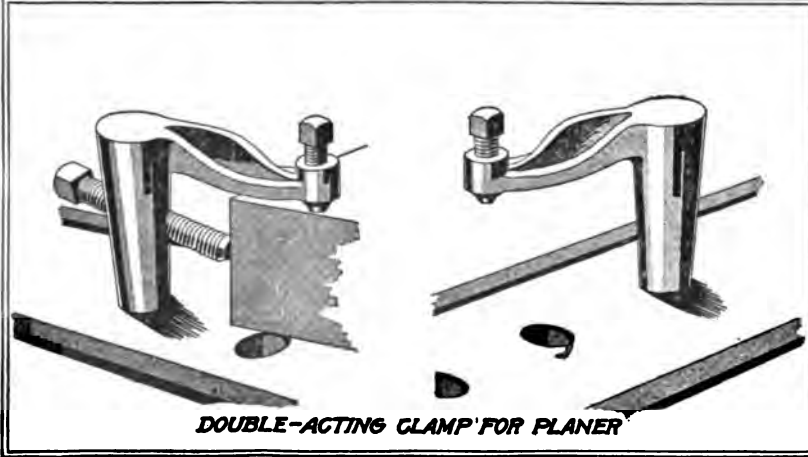
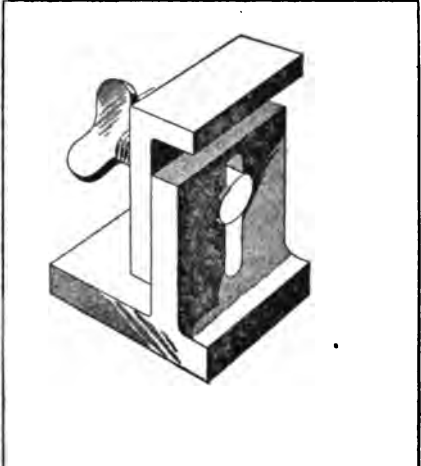
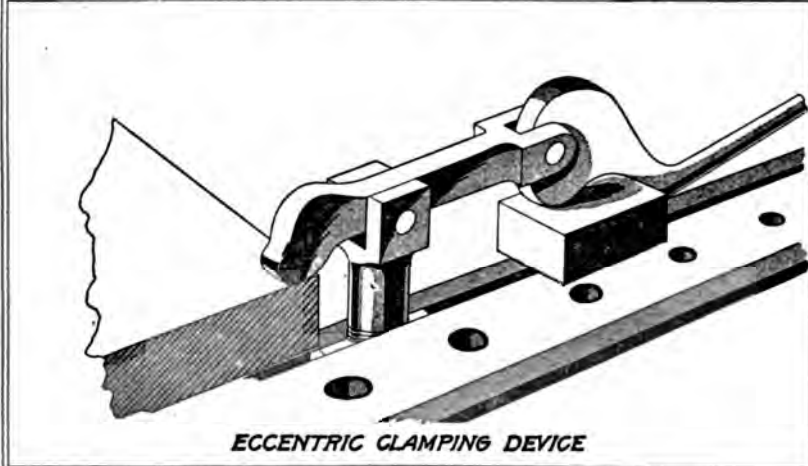
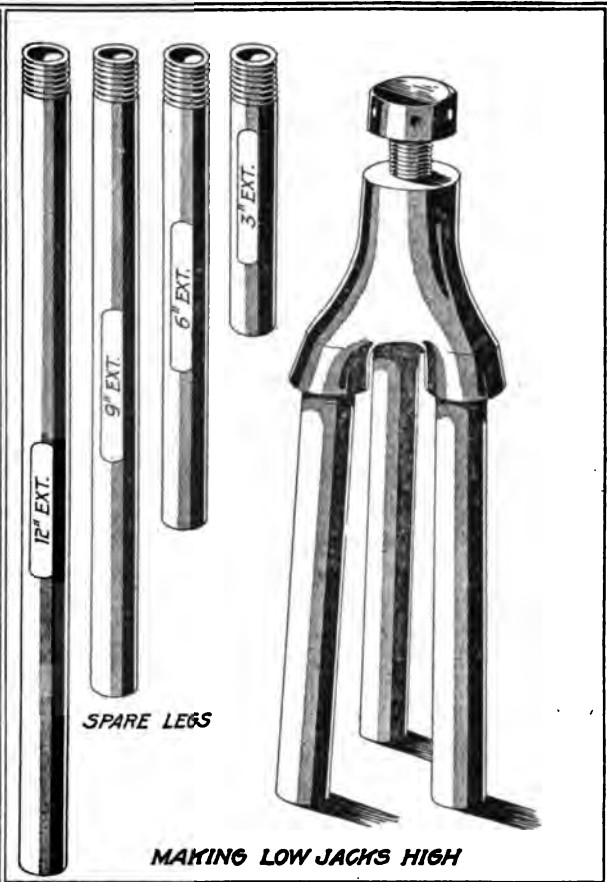
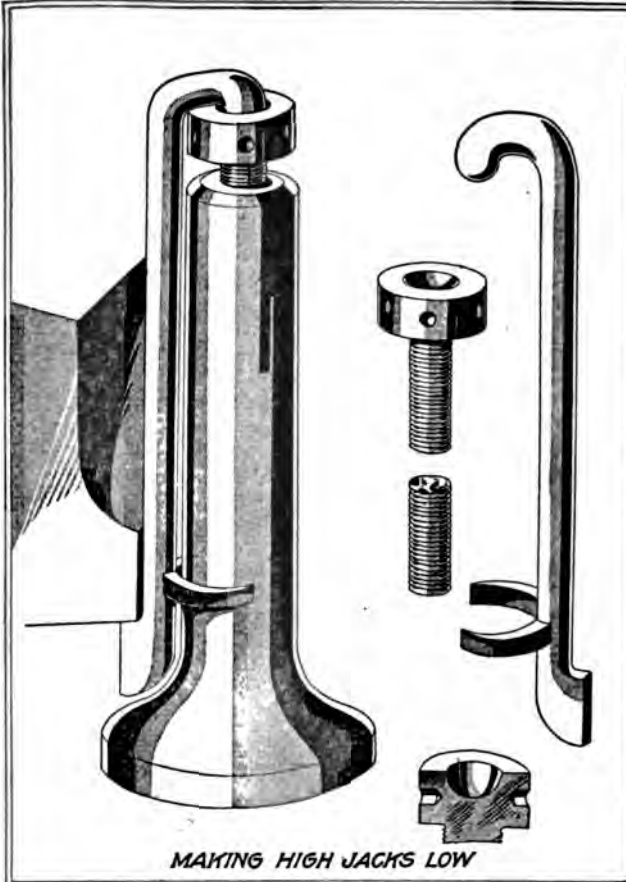

VARIOUS TYPES OF JACKS AND CLAMPS

# From a Small-Shop Notebook

By J. A. LUCAS

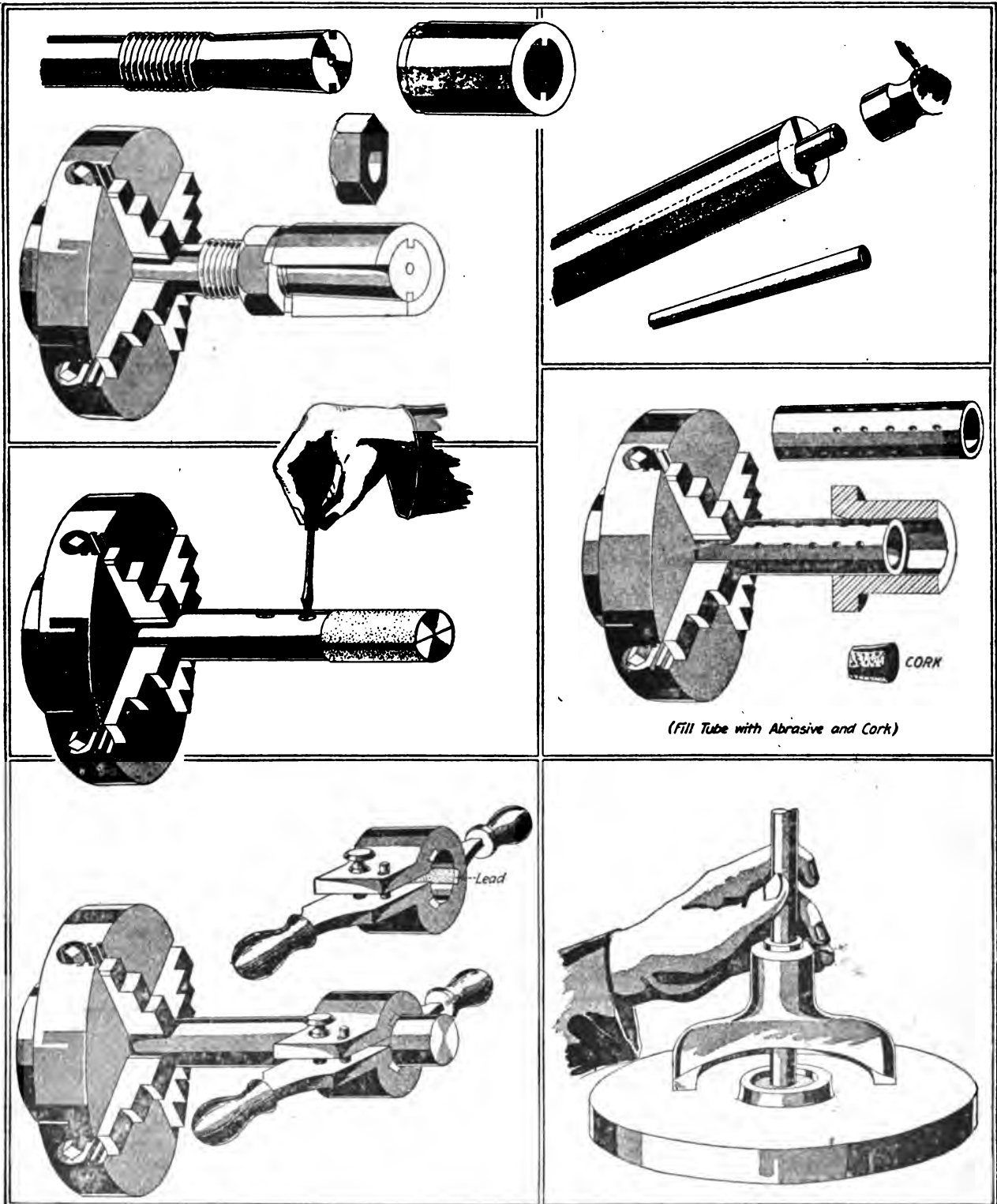

INTERNAL, EXTERNAL AND END LAPPING DEVICES



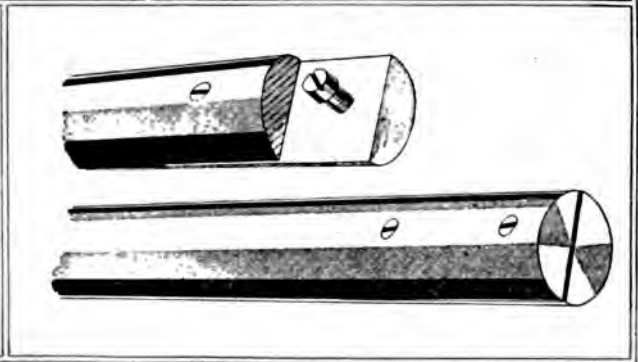
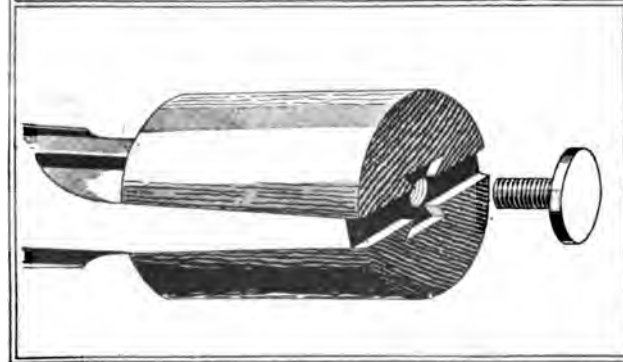
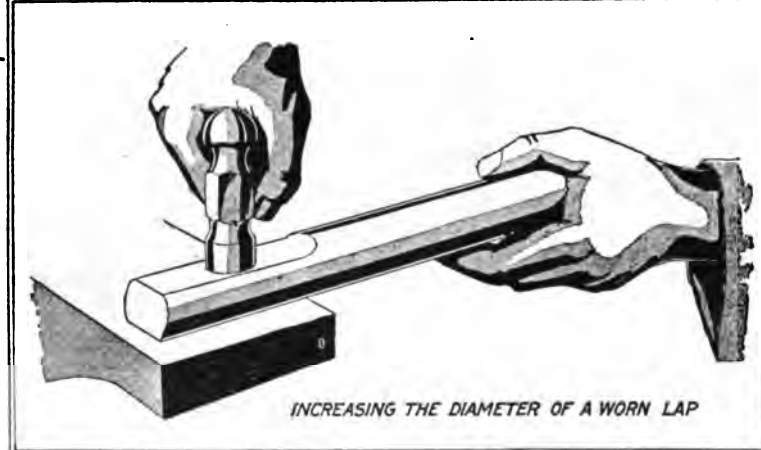
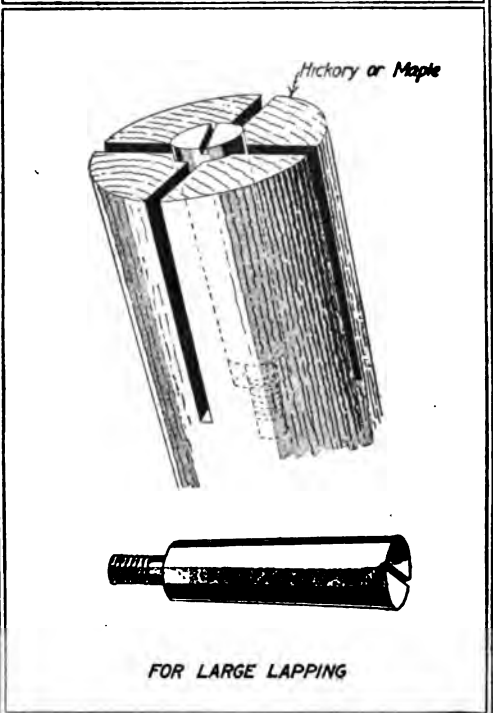
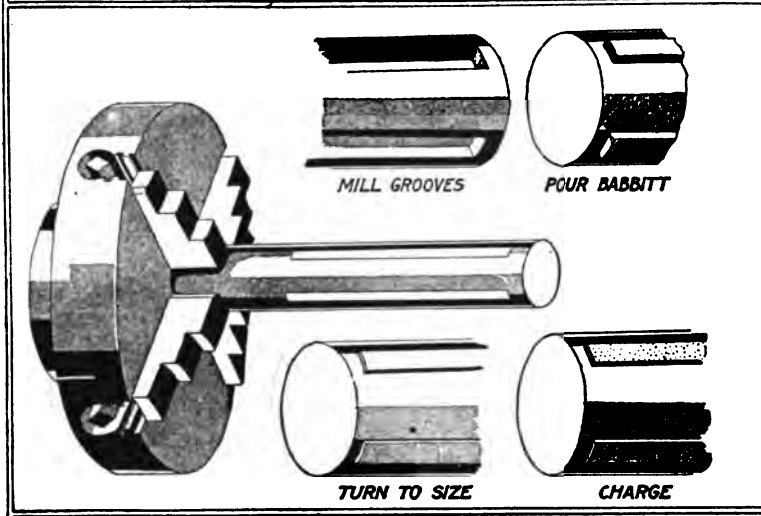
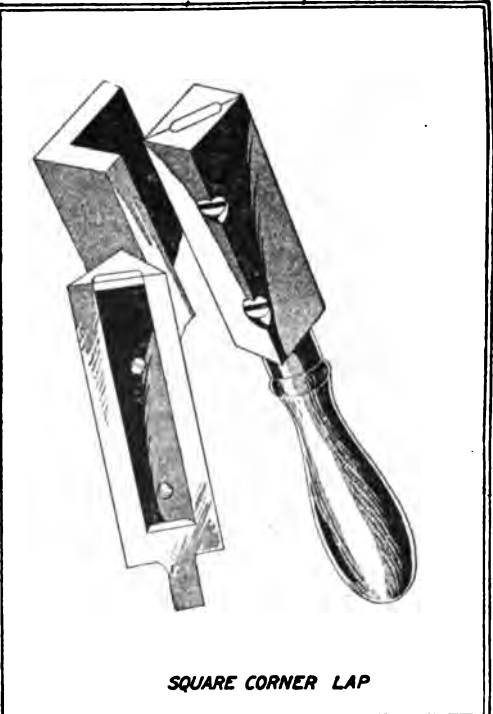
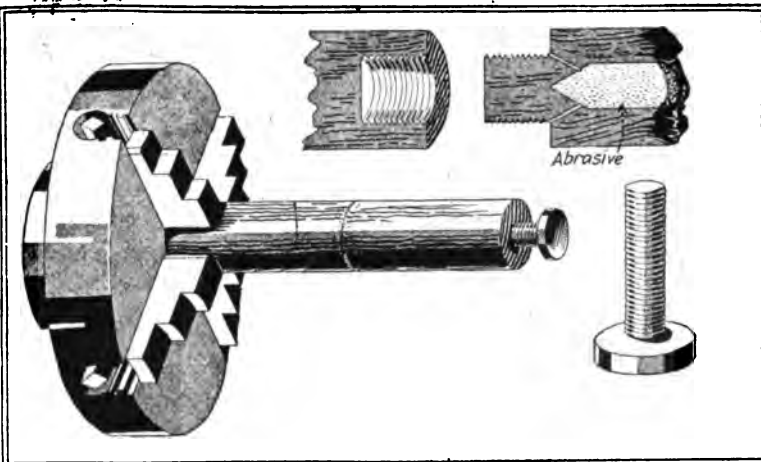

ROUGH INTERNAL LAPPING DEVICES

MAKING SMALL SHOPS PROFITABLE

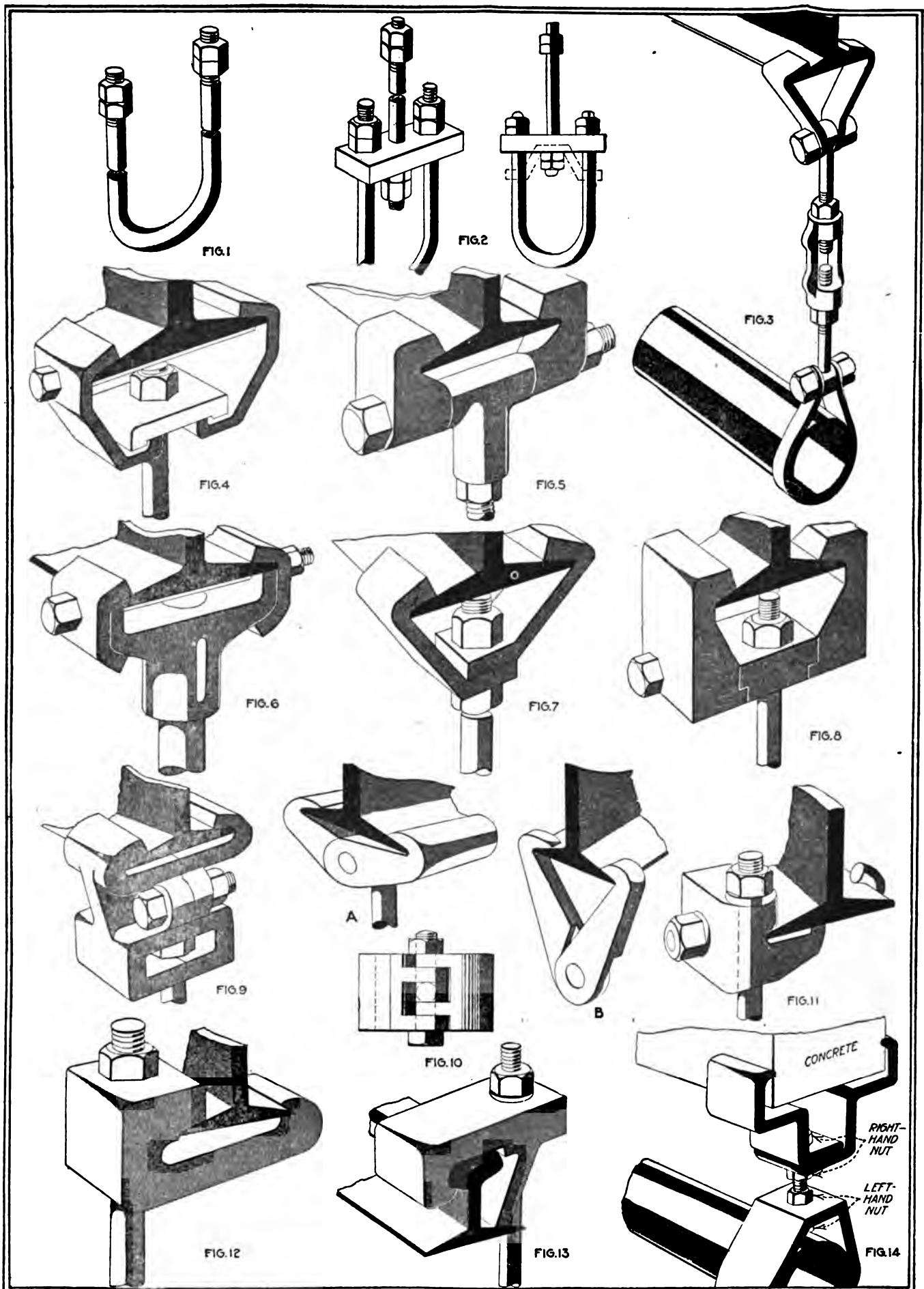

FIGS. 1 TO 14. A NUMBER OF DIFFERENT TYPES OF PIPE HANGERS

# Index

<b>A</b>		Clips for blueprints.....	19	Forge work, adjustable.....	83
Abrasive sheet, fastening on wood roll, etc.....	93	Compounds, good, general.....	60	Forge work, bending with fuller and block.....	82
Alloy steel, heat treatment for case hardening.....	37	Concave radius, planing.....	80	method of making rings.....	82
Aluminum castings, preventing local shrinkage.....	61	Concave surface, turning.....	65	Form turning in engine lathe.....	65
Angle plates, squaring on lathe face plates.....	70	Countersinking attachment for twist drill.....	91	Foundation, method of locating machinery templets.....	50
Angle square, universal.....	79	Crane, handy bench crane.....	105	Foundry, expensive luxuries in small shops.....	12
Angles, bending sharp in vise.....	104	Crane made of iron pipe.....	83	Full gloss finish.....	42
Annealing, saw blades locally.....	64	Cranes, simple crane for bench.....	100	Furnaces, various types for hardening and annealing steel.....	31
Annealing steel.....	32	Crank-pin, special tool for.....	66		
Arbor, adjustable for heavy work..	66	Credit in the small shop.....	1	<b>G</b>	
<b>B</b>		Critical temperature of steel.....	31	Gears, method of inserting teeth in	96
Babbitt, end mill form.....	52	Cupboard, burglar proof, screws for	71	Greases, testing for filling.....	48
Ball centers used for taper turning	78	Curved hole drilling.....	91	testing for rosin and gum.....	49
Bar stock, wedge V block for clamping.....	91	Curves, turning without templet in lathe.....	66	testing for volatile matter.....	48
Bearings, care of in small shop.....	47	Cutter, adjustable boring for finishing.....	72	Grinder in the small shop.....	17
self-aligning.....	47	Cutting oils and compounds, comparative tests for.....	57	Grinder, surface feeds for work... traverse and spindle attachment for lathe.....	17
Belt lace, splitting in bench vise..	62	<b>D</b>		universal in small shop.....	19
Belts, various methods of cutting..	85	Die for drawing, light tubing.....	67	Grinding troubles, causes and remedies for.....	18
Bending rods in vise.....	102	Die sinking shop, a successful small	5	Grinding wheel dressers.....	16
Best way to cut screw threads.....	25	Dipping tanks for different purposes perforated tags for.....	46	Grinding wheels, four methods of mounting.....	14
Bevels, laying out on bars.....	69	Disks, turning round disks on square shears.....	73	how to apply spindle nut.....	15
Blueprints, clips for hanging.....	19	Dividing, circular for shaper.....	92	how to enlarge the hole in.....	16
Boring machine, handling turret work on.....	67	Dock nuts and locking devices.....	74	method for keeping at proper speed.....	15
Boring mill job on engine lathe...	63	Dogs.....	70	safety code for use of.....	16
Boring, profile boring with tail-stock templet.....	66	Double-point surface gage.....	105	safety cover mountings.....	14
Box turning tool for lathe.....	94	Drawers, swinging for small tools..	69	stopping vibration of.....	14
Bushing, quick way to drill.....	67	Drawings, standardizing drawings of machine details.....	53	<b>H</b>	
Bushings, various methods of driving and pulling.....	88	Drill, close quarter.....	62	Hand Eye bender.....	93
<b>C</b>		Drill gaging methods.....	93	Hand Eye twister.....	93
Calipers, convenient method of setting.....	71	Drill press converted into boring machine.....	72	Hand turning device.....	79
Capital, using skill instead of.....	5	Drill, quick method for bushing....	67	Heat treatment of case hardened work.....	37
Carbon steel, case hardening treatment for.....	37	Drill vise, holding two pieces in...	72	Heating baths.....	31
Carbonizing boxes, details of.....	34	Drilling a curved hole.....	91	High skill work in small shops, profitable.....	6
Carbonizing steel.....	34	Drilling machine, circular milling in punch press work on.....	90	High speed steel cutters, tempering small shop specializing in.....	8
Case hardened work, the treatment necessary for.....	37	rotary filling in.....	90	time requirement in hardening...	33
Case hardening, combination cooling tank.....	36	side milling in.....	90	<b>I</b>	
local carbonizing by use of various methods.....	35	surface milling on.....	90	Improvements, limiting in the small shop.....	3
methods of.....	34	Drilling machines, boring pump chambers in.....	33	Improvised tumbling barrel.....	67
penetration of various heats...	35	Dull finish.....	42	Indexing, foot control for indexing vise.....	103
process of.....	34	Dustless shelves.....	105	Indicator, improvised lathe indicator	78
various penetrations.....	35	Dutchman, putting it in right....	73	Internal, external and end lapping devices.....	108
Castings, pickling.....	42	<b>E</b>		Internal hardening kinks.....	93
preventing shrinkage in aluminum	61	Enamel, first and second coat.....	44	Inventive instinct not always possible.....	3
Center bearings.....	63	Engine lathe, form turning in....	65	<b>J</b>	
Center oiling device.....	63	traverse and spindle grinder for..	17	Jacks, adjustable planer.....	107
Center punching kinks, various....	98	used as boring mill.....	63	method of shortening.....	80
Center square.....	79	Expanding arbors, variety of.....	82	shortening and lengthening.....	107
Centering device, simple.....	66	Experience, the kind that sticks...	1	Jigs for use in vise.....	69
Centering, rig for quick centering..	106	Eye bender, hand power.....	93	<b>K</b>	
Chasing threads with pipe tap....	66	Eye twister.....	93	Key waging planer, clamp for.....	84
Chip guard for lathe.....	94	<b>F</b>		Keys, various ways of pulling.....	99
Chip protectors, celluloid.....	70	Face-plate tester.....	78	Knurled effects produced by stamping.....	24
Chipping screen and tool trays, combination.....	100	Filing table, swivel.....	62	Knurling, angles for teeth.....	20
Chrome nickel steel, case hardening treatment for.....	37	Finish, necessity for good on machines.....	41	effect of various tooth impressions hardness of material and effect on teeth angle.....	20
Chuck, wedge chuck for lathes....	70	Flexible coupling.....	47	in the engine lathe.....	23
Chucking block for vise work.....	71	Follower for smooth chucks.....	65		
Chucks, home-made for lathes.....	78	Forge shop, blacksmith's taper gage cranes for.....	83		
Clamp, combination end and side for planer.....	107	dividers for ring work.....	83		
double-acting for planer.....	107	double anti-slip tongs.....	82		
floating jaws.....	91	handy rack for.....	82		
quick work clamp for shaper....	92	keeping mandrel from jumping..	83		
Clamping device, eccentric.....	107	method of heating small parts...	83		
		spring fullers for.....	83		
		stock-measuring gage for anvil...	83		
		tong attachment for forge.....	82		

# INDEX

<p><b>Knurling — <i>continued</i></b></p> <ul style="list-style-type: none"> <li>in small shops..... 20</li> <li>in the vise..... 23</li> <li>method of on screw machines... 22</li> <li>on the chucking lathe..... 23</li> <li>on the milling machine..... 23</li> <li>on the screw machine..... 23</li> <li>on the shaper..... 23</li> <li>on the speed lathe..... 23</li> <li>plain and spiral round..... 21</li> <li>planning the depth of knurl teeth varying the number of tooth im- pressions..... 20</li> <li>Knurls, adjustable triple..... 24</li> <li>holder and spacing collar for... 22</li> <li>master arrangement for cutting concave and convex..... 21</li> <li>method of producing ornamental master..... 24</li> <li>simple attachment for making a spiral knurl on millers..... 21</li> <li>special applications of..... 24</li> </ul>	<p>Oils, lubricating and cutting..... 54</p> <ul style="list-style-type: none"> <li>reducing wastage of..... 56</li> <li>simple testing for viscosity..... 48</li> <li>"old man" applications of..... 97</li> <li>Oval-turning device..... 78</li> </ul>	<p><b>Screw threads — <i>continued</i></b></p> <ul style="list-style-type: none"> <li>two- and three-wire system of measurement..... 29</li> <li>variations..... 29</li> <li>variations in diameter..... 29</li> <li>with incorrect angle..... 28</li> <li>Screws, accurate on thread millers.. 27</li> <li>holding short screws for slotting.. 69</li> <li>Semi-gloss or egg shell finish..... 42</li> <li>Shafts, aligning templets..... 52</li> <li>straightening in place..... 69</li> <li>straightening press made with I- beams..... 62</li> <li>Shaper chucks, lifting..... 30</li> <li>Shaper, circular dividing head for.. 92</li> <li>homemade foot driven..... 84</li> <li>punching thin stock on..... 84</li> <li>quick work clamp for..... 92</li> <li>shaping circular work..... 92</li> <li>tilting table for..... 92</li> <li>Shaping spiral work in shaper..... 92</li> <li>Shear blades, foot operated clamp for 103</li> <li>Shelves, dustless..... 105</li> <li>Slot drilling, improved method of.. 67</li> <li>Small filing clamp for vise..... 104</li> <li>Small tools, swinging drawer for.. 69</li> <li>Socket wrench, folding..... 93</li> <li>Spherical turning, device for inter- nal..... 78</li> <li>Spirals, cutting on planer..... 80</li> <li>Spring fever, curing in the small shop..... 10</li> <li>Spring, utilizing hand drill for wind- ing..... 91</li> <li>way to make a heavy..... 66</li> <li>winding and cutting methods... 87</li> <li>Steel annealing..... 32</li> <li>Steel, carbonizing..... 34</li> <li>critical points..... 31</li> <li>decarbonization, preventing in taps and reamers..... 32</li> <li>easing off internal stresses in.... 32</li> <li>fast heating to be avoided..... 32</li> <li>hardening and annealing in small shops..... 31</li> <li>hardening in brine solution..... 32</li> <li>loss of magnetic property at criti- cal temperature..... 31</li> <li>methods of heating for hardening and annealing..... 31</li> <li>rough cutting before hardening.. 32</li> <li>water annealing of..... 33</li> <li>Stock rest and tool-shelf combined.. 15</li> <li>Sulphur in oil, testing for..... 48</li> <li>Surface gage with double points.. 105</li> <li>Surface grinding attachment applied to planer..... 17</li> </ul>
<p><b>L</b></p>		
<p>Lapping devices, internal, external and end..... 108</p> <ul style="list-style-type: none"> <li>rough internal lapping..... 109</li> <li>Lard oil and lard oil mixtures.... 58</li> <li>Lathe, box turning tool for..... 94</li> <li>center protector for..... 95</li> <li>Lathe chuck, home-made..... 78</li> <li>improvised with screw adjustment 70</li> <li>Lathe chuck on wedge principle... 70</li> <li>Lathe faceplate tester..... 78</li> <li>Lathe, grinding, boring tool for scale 95</li> <li>Lathe hand wheel spanners..... 106</li> <li>improvised screw chuck for..... 70</li> <li>method of fitting tool in..... 95</li> <li>methods of testing height of tool with scale..... 95</li> <li>oval-turning device for..... 78</li> <li>screw cutting on..... 27</li> <li>testing device for..... 95</li> <li>tool post, special for crank pin.. 66</li> <li>turning curve without templet... 66</li> <li>Lathes, chip guard for..... 94</li> <li>follower for small work..... 94</li> <li>graduated boring bar for..... 94</li> <li>improvised taper attachment for.. 65</li> <li>milling in..... 63</li> <li>multiple tools in..... 65</li> <li>rigging up to cut quick leads... 25</li> <li>roughing and finishing tool com- bined..... 94</li> <li>screw machine job in..... 65</li> <li>squaring angle plate on face plate 70</li> <li>Leads, quick, rigging up to cut in lathes..... 25</li> <li>Length gage used in vise..... 102</li> <li>Long work, supporting in vise..... 102</li> <li>Lubricant practice, standardizing.. 61</li> <li>Lubricants, applying to tools..... 60</li> <li>testing, cutting..... 57</li> <li>Lubrication, record of..... 61</li> </ul>	<p><b>P</b></p> <ul style="list-style-type: none"> <li>Paint brushes, keeping in condition 44</li> <li>proper size and shape of..... 43</li> <li>Painting by dip-tank method..... 45</li> <li>Painting by spray..... 46</li> <li>Painting department, constitution of 43</li> <li>Paints, overcoming disadvantage of 43</li> <li>Pattern turning on planer..... 84</li> <li>Patterns and castings, making for small shop..... 12</li> <li>obtaining weight by displacement 9</li> <li>Patterns, getting them made for small shops..... 13</li> <li>Peripheral speed of grinding wheels, in terms of revolution..... 16</li> <li>Pickling castings..... 42</li> <li>Pins, getting a grip on..... 69</li> <li>shearing in lathes..... 63</li> <li>various ways of cutting in quan- tities..... 86</li> <li>Pipe, bending in vise..... 102</li> <li>devices to facilitate brazing.... 82</li> <li>Pipe hangers, various types of.... 110</li> <li>Pipe riveting horn for vise..... 104</li> <li>Pipe tap, tracing threads with.... 66</li> <li>Pipe wrench for finished work.... 73</li> <li>Planer chuck, lifting..... 62</li> <li>Planer, combination end stop and side-clamp for..... 68</li> <li>cutting racks on..... 80</li> <li>cutting spirals on..... 80</li> <li>double-acting clamp for..... 107</li> <li>handling oversize job on..... 84</li> <li>jacks adjustable..... 107</li> <li>signal for..... 68</li> <li>surface grinder attachment for.. 17</li> <li>templet work on..... 80</li> <li>turning patterns on..... 84</li> <li>Planing concave radius..... 80</li> <li>Planing to templet..... 80</li> <li>Protecting mandrel centers..... 79</li> <li>Pulley, reboring by hand..... 71</li> <li>Pulling keys, various ways of.... 99</li> <li>Pump chambers, boring in drilling machine..... 33</li> <li>Punch bar, graduated..... 67</li> <li>Punch, for thin sheets..... 62</li> <li>Punching, light metal in vise..... 104</li> <li>Punching thin stock on shapers... 84</li> <li>Pyrometer, thermocouple type..... 39</li> <li>Pyrometers, checking up cold ends.. 40</li> <li>expansion type..... 39</li> <li>in small shops..... 38</li> <li>keeping in condition..... 40</li> <li>protecting sheaths for fire ends.. 40</li> <li>temperature indicators and record- ers..... 40</li> <li>various types suitable for small shops..... 38</li> </ul>	<p><b>T</b></p> <ul style="list-style-type: none"> <li>Tail centers, self-lubricating..... 65</li> <li>Tanks, taking kinks out of closed.. 71</li> <li>Tap drill sizes, tapping by hand, ex- pense of..... 26</li> <li>Tap, measuring pitch diameter with wires..... 30</li> <li>removing broken..... 62</li> <li>Tap wrench, triple action..... 73</li> <li>Taper attachment on lathe..... 65</li> <li>Taper turning with ball centers... 78</li> <li>Tapping thin tubes..... 65</li> <li>Taps, comparing lead of, with lead screw..... 30</li> <li>measuring outside diameters of.. 30</li> <li>method of extracting broken.... 73</li> <li>methods of enlarging..... 67</li> <li>preventing decarbonization..... 32</li> <li>reducing size of..... 67</li> <li>testing for warp between lathe centers..... 29</li> <li>three ways to square hand taps.. 64</li> <li>Temperature indicating outfits, cost of..... 40</li> <li>Templet, making an accurate..... 64</li> <li>Templet testing hood..... 100</li> <li>Test indicators, improvised..... 106</li> <li>Thread cleaners, simple..... 63</li> <li>Threading long shaft on two lathes. 63</li> <li>Threading with leader on drilling machine..... 27</li> </ul>
<p><b>M</b></p>		
<p>Machine details, standardizing draw- ings of..... 53</p> <ul style="list-style-type: none"> <li>Machinery, lubricating oils for... 50</li> <li>Machines, how the purchase of one affected shop future..... 7</li> <li>Mandrel centers, protecting..... 79</li> <li>Mill, end for babbitt..... 52</li> <li>Milling, form milling to templet... 67</li> </ul>	<p><b>R</b></p> <ul style="list-style-type: none"> <li>Rack cutting on planer..... 80</li> <li>Reamer, simple flat reamer with wood packing..... 72</li> <li>Reboring, pulley by hand..... 71</li> <li>Rings, cutting brass oil rings on wood arbors..... 70</li> <li>simple fixture for forming wire.. 64</li> <li>Rough internal locking lapping... 109</li> </ul>	
<p><b>N</b></p>		
<p>Number of different types of pipe hangers..... 110</p>	<p><b>S</b></p> <ul style="list-style-type: none"> <li>Sand blasting for machine finish.. 42</li> <li>Saw, local annealing of..... 64</li> <li>Screw cap, quick lathe chuck for.. 70</li> <li>Screw cutting on lathe..... 27</li> <li>Screw machine work in lathes..... 66</li> <li>Screw threads..... 25</li> <li>limit gage for..... 29</li> <li>measuring..... 28</li> </ul>	
<p><b>O</b></p>		
<p>Oil grooving with twist drill..... 64</p> <ul style="list-style-type: none"> <li>Oil rings, cutting on wood arbors.. 70</li> <li>Oil, testing for sulphur..... 48</li> <li>various tests for impurities.... 47</li> <li>Oiling device, for lathe centers... 63</li> <li>Oils and compounds, care and distri- bution of..... 60</li> </ul>	<p><b>T</b></p> <ul style="list-style-type: none"> <li>Temperature indicating outfits, cost of..... 40</li> <li>Templet, making an accurate..... 64</li> <li>Templet testing hood..... 100</li> <li>Test indicators, improvised..... 106</li> <li>Thread cleaners, simple..... 63</li> <li>Threading long shaft on two lathes. 63</li> <li>Threading with leader on drilling machine..... 27</li> </ul>	

# INDEX

Threads, milling with single and multiple cutters .....	28
Tight grip for vise .....	100
Tilting table for shaper .....	92
Tool rack for lathe and boring mill tools .....	79
Tool-shelf and stock rest combined ..	105
Tool tray and chipping screen, combination .....	100
Toolmakers' clamp .....	73
Tools, multiple in lathes .....	65
Treatment of case hardened work ..	37
Tubes, tapping thin .....	65
Tubing, die for drawings, light .....	67
Tumbling barrel .....	67
Turning concave surface .....	65
Turning device for turning by hand ..	79
Turning point in the small shop .....	7
Turret work, handling on boring machine .....	67

## U

Universal angle square .....	79
Universal grinder in the small shop ..	19

## V

V blocks, adjustable for length ...	73
made from round pipe .....	72
universal for round stock and spheres .....	72
Various methods of cutting belts ..	85
Vibration of grinding wheels, stopping .....	14
Viscosity, testing oils for .....	48
Vise, chucking block for quick chucking .....	71
drilling in .....	102
drilling in bench vise .....	102
foot-operated clamp for shear blade .....	103
jaws for bending sharp angles ...	104
jigs .....	69
kinks, number of handy .....	102
knee operated .....	103
length gage for .....	102
pipe bending in .....	102
pipe-riveting horn .....	104
punching light metal in .....	104
sheet-metal filling clamp .....	104

## Vise — continued

small filing clamp for .....	104
spring chuck, foot operated .....	103
supporting long work in .....	102
temporary screw repair for .....	104
tight grip for .....	100
use of bending fixture .....	102

## W

Water compounds for cutting, effect of .....	59
Weight of patterns, obtaining by displacement .....	9
Welding and brazing torches, fire-proof receptacle for .....	73
Wing nuts, gripping in vise .....	71
Wire measurement method for screw threads .....	29
Wire ring fixture .....	64
Wires, kink remover for .....	69
Work bench, handy rig for .....	101
Wrench, emergency adjustable wrench .....	71
emergency pipe wrench .....	64
Wrench protector .....	93



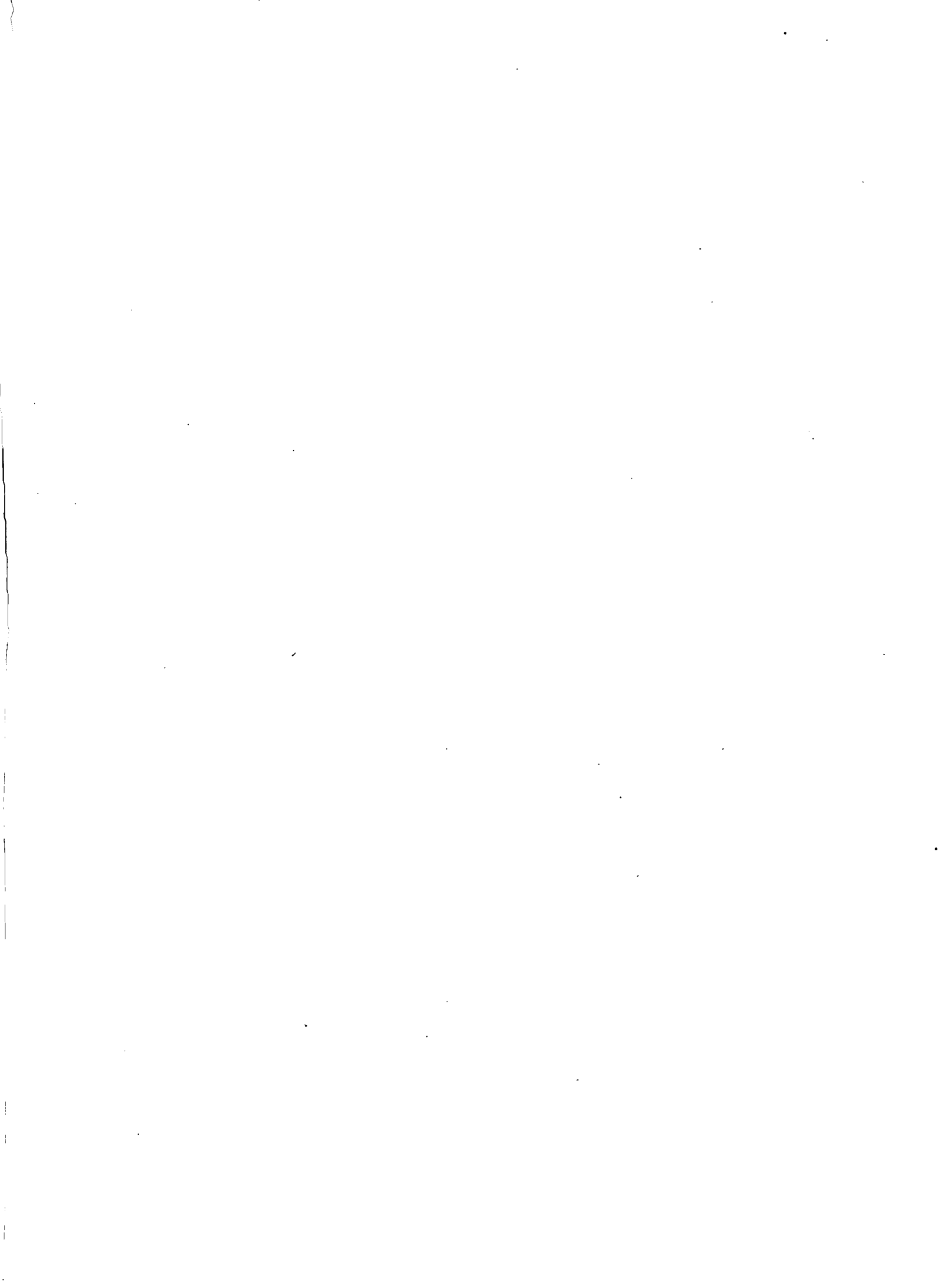





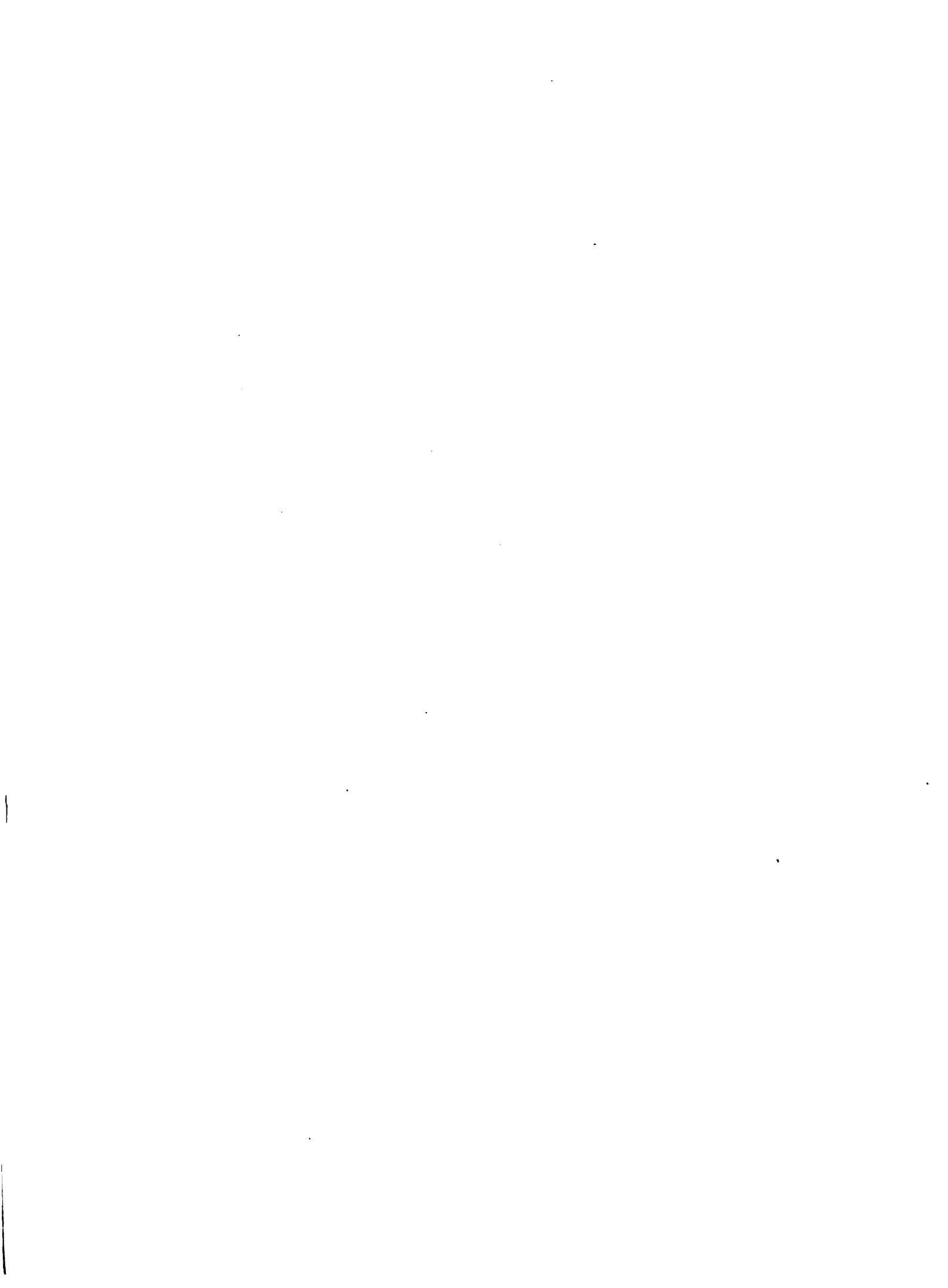



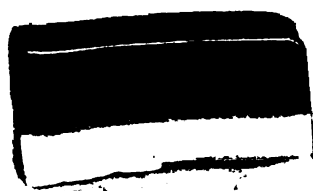
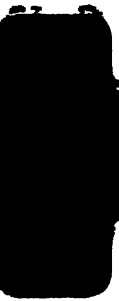
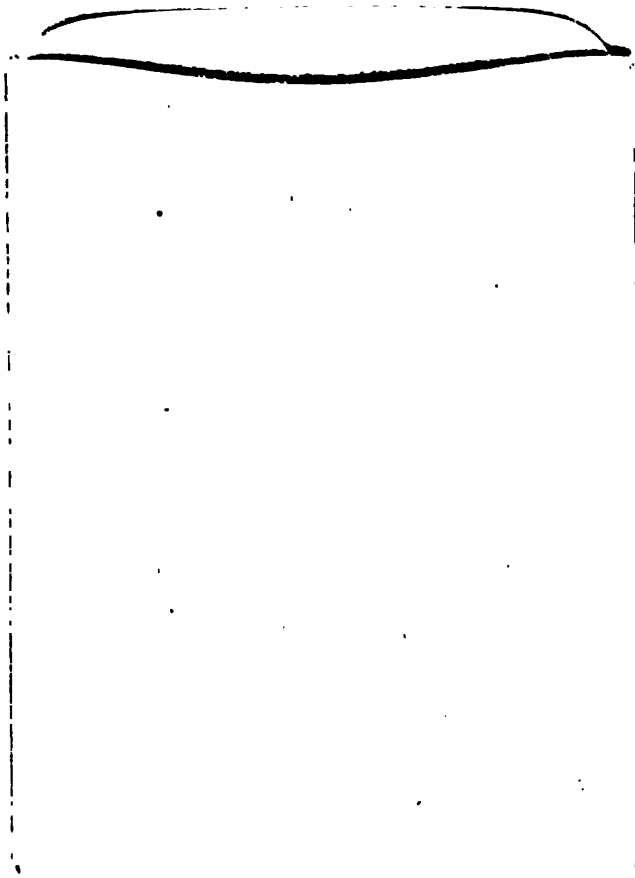

89089664890



b89089664890a