

A

RUDIMENTARY TREATISE

ON THE

INTEGRAL CALCULUS.

BY HOMERSHAM COX, B.A.

BARRISTER AT-LAW;

AUTHOR OF A "MANUAL OF THE DIFFERENTIAL CALCULUS."

LONDON:

JOHN WEALE, 59, HIGH HOLBORN.

1852.

LONDON :
GEORGE WOODFALL AND SON,
ANGEL COURT, BRINKER STREET.

PREFACE.

THE Differential and the Integral Calculus have been established upon entirely different axioms and definitions by the several founders of those sciences. The primary ideas of infinitesimals, fluxions, and exhaustions, though their results coincide, for the simple reason that all pure truth is consistent with itself, are widely diverse in their abstract nature. In writing, therefore, on the principles of either Calculus, a difficulty presents itself in the necessity of electing between systems, each of which has the sanction of high authority and peculiar intrinsic merits.

This consideration is of especial importance in a "Rudimentary Treatise," which cannot, of course, fulfil the profession of its title without singleness and simplicity of its fundamental ideas, and an exactness of thought and language often very difficult of attainment. The choice of methods in the present work has been determined partly by historical considerations. The discoverers of new truths usually search after them by the simplest and most familiar considerations; and it seems natural to presume that, as far at least as abstract principles are concerned, the way of discovery is the easiest way of instruction.

The original idea upon which Newton based the system of fluxions, regarded a differential coefficient as the rate of increase of a function. The idea upon which Leibnitz and the Bernouillis established the Integral Calculus, regarded an integral as the limit of the summation of an indefinite number of indefinitely diminishing quantities. The facility

with which the idea of "rate" may be conceived and applied to the science of which Newton was the great founder, and the similar advantages of the idea of summation in the Integral Calculus, determined the selection of the first idea as the basis of the "Manual of the Differential Calculus" by the present writer, and the second as the basis of the present treatise.

The value and importance of what is termed by Professor De Morgan the "summatory" definition of integration, has been insisted upon by him and others of the most eminent modern mathematicians; but the present is probably an almost solitary attempt to establish the Integral Calculus on that definition exclusively. Throughout the entire range of the practical applications of the Integral Calculus—to Geometry, Mechanics, &c.—the idea of summation is solely and universally applied. The rival definition of the Integral Calculus—as the inverse of the Differential Calculus—has a merely relative signification, and is, therefore, essential only in analytical investigations of the relations of the two sciences.

But whatever system be adopted for establishing either calculus must of necessity involve the idea of limits and limiting values. An unreasonable reluctance has been sometimes exhibited in adopting this idea in elementary treatises, whereas that it is one by no means difficult to be conceived is shewn by its adoption in the first ages of mathematics. By far greater difficulties have arisen from the shifts to which resort has been had to evade it in theorems of which demonstrations without it are necessarily illogical.

The idea of limits occurs, or ought to occur, much earlier in the study of exact science than is generally allowed. This idea is essentially involved in Arithmetic, Euclid, and Algebra. The laws of operation with recurring decimals and surds cannot be accurately established without limits—for in what sense is the fraction $\frac{1}{3}$ equal to $.3333\dots$, or $\sqrt{2}$ equal to another interminable decimal, except as the limits of the two infinite convergent series represented by the decimals? Euclid's definition of equality of ratios

(Book V., Def. V.), is made to include incommensurable ratios by considerations dependent on the method of limits, which also occurs repeatedly in Book XII. In Algebra, as the present writer has endeavoured to shew elsewhere (*Cambridge Mathematical Journal*, Feb., 1852), an exact demonstration of the Binomial Theorem must involve the method of limits. The same remark applies to the operation of equating indeterminate coefficients and the theorem $a^0 = 1$. Neglect of these considerations involves the writers of some treatises in obscurities, errors, and inconsistencies, which bring to remembrance the supposed common origin of the words "gibberish" and "algebra."*

Throughout the present work, the language of infinites and infinitely small quantities has been carefully avoided, partly because they cannot, except by an inaccuracy of language, be spoken of as really existing magnitudes which may be subjected to analytical operations, partly because the language of the method of limits is equally concise, and is, moreover, exact.

That infinity has a real existence must be admitted; for let us conceive any distance, however great, such that the remotest known star is comparatively near: we cannot say that space terminates at that distance. What is beyond the boundary? A void, perhaps, but still space; so that unless we can conceive the existence of a boundary which includes all space within it, and to which no space is external, we are forced to admit the existence of infinite space. But this admission is altogether different from that which subjects infinity to mathematical operations. How is the infinity thus operated upon to be defined? As a magnitude than which none other is greater? But by hypothesis it is the subject of analytical

* Algebra.—"Some, however, derive it from various other Arabic words, as from Geber, a celebrated philosopher, chemist, and mathematician, to whom they ascribe the invention of this science."—*Hutton's Mathematical Dictionary*. Gibberish.—"It is probably derived from the chemical cant, and originally implied the jargon of Geber and his tribe."—*Johnson's Dictionary*.

operations, and therefore of addition. Add, therefore, some quantity; the result is greater than this infinity, or the definition is contradicted. The truth is, that absolute infinity, such as the infinity of space, cannot be intelligibly conceived on the supposition that anything can be added to it.

Similar considerations apply to infinitely small quantities. There is no difficulty in seeing, that of any kind of magnitude the parts may be diminished infinitely, for, however small a part be taken, it may be divided, and thus smaller parts are taken. If, then, an infinitesimal quantity, the subject of analytical operation, be defined to be a real quantity less than any other, the definition may be readily shewn to be inconsistent with itself.

When, therefore, infinitesimals and infinity are introduced into mathematical operations, they ought to be regarded not as having an absolute existence, but merely as the means of expressing the *limits* to which results approach, as quantities in them are continually increased or diminished.

M. Cournot, in his admirable treatise "*Des Fonctions et du Calcul Infinitesimal*" (Paris, 1841), asserts, indeed, that the infinitesimal method does not merely constitute an ingenious artifice; that it is the expression of the natural mode of generation of physical magnitudes which increase by elements smaller than any finite magnitude. But he does not appear to have anywhere defined what he understands by elements smaller than any finite magnitudes; and without such a definition it is impossible to investigate his proposition accurately. If the words of it be interpreted literally it appears to lead to this dilemma: if the elements be not magnitudes, the addition of them produces no increase—if they be magnitudes, they cannot be less than any finite magnitude; for, being magnitudes, they may be divided into less magnitudes.

With respect to the method of limits, M. Cournot is of opinion that questions must occur in which it is necessary to renounce this method, and to substitute for it in language

and in calculations the employment of infinitely small quantities of different orders. He has not, however, specified any instance in which the substitution in question is required.

The following demonstrations do not refer directly or indirectly to different orders of small quantities, nor, indeed, to small quantities at all; for the use of the term "small," in an absolute sense, in mathematics, is objectionable on account of its inexactness. The limit where greatness ceases and smallness begins cannot be distinguished. Hence, though one quantity may be accurately said to be smaller than another, the former cannot with perfect exactness be said to be necessarily and absolutely small with respect to the latter.

The exclusive adherence to the "summatory" definition of the Integral Calculus, has rendered it necessary to present the greater part of the following propositions in a new form, and scarcely anything here given (except the historical notices) is compiled from analogous treatises. The first section contains a popular exposition of the Integral Calculus; and the second a brief account of its history, compiled from one or two cyclopedias and dictionaries. The two following sections are probably in a great measure new, as in them the general principles of integration and the integration of the fundamental functions are derived from the definition above referred to. The three short sections which succeed contain nothing original; but the eighth, on Rational Fractions, is almost entirely newly written. The ordinary demonstration of the possibility of resolving a rational fraction into partial fractions proceeds by the method of equating coefficients, and is defective in this respect—that it neglects to shew, *à priori*, that the assumed coefficients have any real existence, and that the equations determining them do not give impossible or inconsistent results.

To the kindness of PROFESSOR DE MORGAN, of University College, London, the Author is indebted for an exact demonstration of the existence of partial fractions corresponding to rational fractions, with denominators resolvable

into simple factors. Similar obligations have been conferred by MR. COHEN, of Magdalene College, Cambridge, by his analogous demonstration respecting quadratic factors. In a subsequent part of the section, a method of effecting these resolutions is proposed, which may, perhaps, save some labour.

In the ninth section a hint has been taken from Moigno's edition of Cauchy's "Leçons de Calcul Integral," to generalize in some measure the principles of Rationalization.

In the next chapter the "summatory" definition is extended to Multiple Integrals. The Quadrature of Curves and the Cubature of Solids are next considered; and a method, which is probably new, is given, of investigating the cubature by polar co-ordinates, by considering surfaces to be generated by the revolution of figures of *variable form*.

The theories of rectification of curves and complanation of surfaces have some difficulties which are frequently evaded by illogical reasoning. In the "Principia," the method of rectification is based on the fifth Lemma—"the homologous sides of similar figures are proportional." This is stated without demonstration, and is intended to be axiomatic. It assumes, in other words, that if any figure be drawn to a reduced scale, the linear dimensions of the corresponding parts are in the ratio of the scale of the original to that of the copy. Certain Cambridge versions of Newton's Lemmas, among other mutilations of the original, have attempted to prove this axiom respecting *lengths*, by reference to a proposition respecting *areas*, of which the evidence is of a totally different kind.

Some continental writers, amongst whom is M. Cournot, have thought to avoid all difficulty respecting the fundamental principles of rectification and complanation, by defining curves and surfaces to be respectively polygons and polyhedrons of indefinitely small sides. But it is, in truth, a mere postponement of difficulty to invent new definitions to answer special purposes. The methods of measuring curves and surfaces, as defined by M. Cournot, are, perhaps,

to be connected with his views respecting small quantities, but cannot be considered complete until extended by rigorous reasoning to surfaces and curves generated by continuous motion—such as solids of revolution and their sections. An essay is made in the following pages to establish the principles of this part of the Integral Calculus on very simple geometrical axioms, and the formula of complanation is proved without the usual reference to the inclination of tangent planes.

A consideration of the integration of functions which become discontinuous or infinite for particular values, appeared necessary to complete the subject, and an attempt has been made to elucidate the definition of multiple integrals of discontinuous functions. In the concluding section, an investigation of some of the properties of the second Eulerian integral is partly taken from Littrow's "*Anleitung zur höheren Mathematik*;" but in the original proofs an important defect exists, to remedy which, the article on ultimate ratios of Eulerian integrals has been given. The demonstration of the fundamental relation between the two kinds of such integrals is that of Poisson, as given by M. Cournot. Some remarks are offered on the inexactness of evaluations of the sine and cosine of an infinite angle.

Several invaluable suggestions of Professor STOKES, the Lucasian Professor of Mathematics at Cambridge, have been embodied in the two concluding chapters; and the obligations thus conferred are acknowledged by the Author with a feeling of great gratification.

Geometrical representations of analytical theorems have been frequently introduced for the purpose of illustration, but not of demonstration; for though the proof of purely analytical theorems of the Integral Calculus is independent of the extrinsic aid of geometry, they are often remarkably elucidated by being considered objectively.

CONTENTS.

[The Numbers designate Articles referred to.]

SECTION

I. GENERAL NATURE OF THE INTEGRAL CALCULUS.

II. EARLY HISTORY.

III. PRINCIPLES OF INTEGRATION.

Definitions, 11-14, 16, 17, 23-25. Limit of functions, 15. Quadrature of areas, 19. Limits of quadratures, 20, 21. Integral between its quadratures, 22. Integral, a function of its limits, 26. Sum of integrals with consecutive limits, 27. Integration inverse of differentiation, 31. Addition and multiplication of integrals, 32, 33. Integration by parts, 34, 35. Transformation by change of variable, 37, 38. Indefinite integration, 40. Differentiation of integrals, 41.

IV. FUNDAMENTAL INTEGRALS.

Integration of a^x , 42; of $\frac{1}{x}$, 43; of $\log x$, 44. Bernoulli's series, 45. Value of e , 46. Integrals of trigonometrical functions, 47-52; of $(x^2 + a^2)^{-1}$, &c., 53-59. Methods of integration classified, 62.

V. ALGEBRAICAL TRANSFORMATION.

$(a + bx + cx^2 + \dots)^n$, 64; $(\log x)^n$, 68; functions of $a + bx$, 70; functions of $a^2 \pm x^2$, 71.

VI. INTEGRATION BY PARTS.

VII. FORMULÆ OF REDUCTION.

Extension of Bernoulli's series, 81. Integrals of $(a^2 - x^2)^{\frac{n}{2}}$, 83; of $(A + Bx) \cdot (x^2 + 2\delta x + c)^{-n}$, 85.

VIII. RATIONAL FRACTIONS.

Definitions, 86-88. Every rational fraction may be resolved into partial fractions, 87-97. Form of result of the resolution, 98. Resolution by equating coefficients, by substitution, by differentiation, 99-101. Cases of quadratic factors, 102-104.

SECTION

IX. RATIONALIZATION.

To rationalize a function partly rational and partly irrational, 108.
Product of a rational and irrational function, 109. Criteria of integrability, 111.

X. INTEGRATION WITH SEVERAL VARIABLES.

Definition of multiple integrals, 115, 116. Multiple integrals found by successive integrations, 117. Order of integration indifferent, 118. Illustration, 119.

XI. QUADRATURE OF CURVES.

Circle, 122. Ellipse, 123. Oblique co-ordinates, 124. Hyperbola, 125. Area between asymptotes, 126, 127. Polar co-ordinates, 128, 132. Area in terms of length of curve, 134. Negative co-ordinates, 135, 136.

XII. CUBATURE OF SOLIDS.

General formula, 137. Limits of integration, 138, 139. Solids of revolution, 141-144. In terms of area, 146. Cubature by polar co-ordinates, 147-149.

XIII. RECTIFICATION OF CURVES AND COMPLANATION OF SURFACES.

Lemmas, 150, 151. Curve, the limit of a polygon; limit $\frac{\text{chord}}{\text{arc}}$, 152. Rectification, 153. Curved surface the limit of a polyhedron, 154. Complanation, 156.

XIV. DISCONTINUOUS FUNCTIONS.

Errors arising from integration of discontinuous functions by ordinary rules, 158. Definition of integrals of discontinuous functions, 159. "Principal" integrals, 160. Conditions of determinateness, 161. Geometrical illustrations, 162. Multiple integrals, 164. Definition, 165.

XV. DEFINITE INTEGRALS.

Eulerian integrals, 168-176. $\int_0^{\infty} dx e^{-ax} \cos bx$, 171.

$\sin ax$, 172, 173. Differentiation of definite integrals, 174.

$\int_0^{\infty} dx e^{-a^2x^2} \cos 2cx$, 175.

APPENDIX.

Taylor's Theorem.

INTEGRAL CALCULUS.

SECTION I.

GENERAL ACCOUNT OF THE OBJECTS OF THE INTEGRAL CALCULUS.

1. **AMONGST** the most important uses of the Integral Calculus are its applications to the measurement of the lengths of curves, the areas of curvilinear figures, the contents of solids contained by curved surfaces, and the effects of forces. This Calculus is required in the most important investigations in every branch of the exact sciences.

2. The names of the Integral and Differential Calculus sufficiently indicate the distinction between them. The Integral Calculus determines the whole sum or integral magnitude of a quantity of which the differential parts are given. The Differential Calculus, on the contrary, investigates the relations of the differential parts of a quantity of which the integral magnitude is given.

3. The process of Integration is therefore the inverse of Differentiation; in the same way as Subtraction is the inverse of Addition, Division the inverse of Multiplication, Evolution the inverse of Involution. But in the same sense that Integration is the inverse of Differentiation, the latter operation is the inverse of the former. As, therefore, the Differential Calculus is defined and investigated irrespectively of the Integral, so may also the Integral independently of the Differential. It is an unnecessarily restricted view which regards the Integral Calculus as a dependent science. Throughout the following pages its rules will be independently demonstrated; though the close relation between the two Calculi requires careful consideration, for the sake of its aid in comprehending both subjects, its suggestiveness in investigation, and its test of results by inverse operation.

4. It was said above, that the Integral Calculus determines the integral magnitude of a quantity from its differential parts. Now of course this indirect method of measurement would not be usually resorted to, if a more direct were practicable. But there are innumerable cases in which direct measurement is impracticable. The measurement of the lengths of lines affords a simple illustration. If the lines be straight, the method of measuring them is obvious and direct. It consists in successive applications of a straight "rule" or standard of a unit of length (a yard, metre, ell, &c.), along the straight line to be measured, and ascertaining how many times it contains the unit and known parts of it. But if the line to be measured be a curve, no such application of a straight "rule" can be performed; it will coincide with the curve no portion of it, however small.

5. A rough way of effecting the required measurement is, however, readily suggested. A number of points be arbitrarily taken in the curve, and be joined, or be



posed to be joined, by dotted lines. Then, if these be measured, their total length is an approximate measure of the length of the curve.

6. It was long ago perceived, that by diminishing lengths of the chords, and increasing their number, the approximation became closer and closer. An improvement of the method was effected by drawing from the extremities intermediate points of the curve, tangents meeting each at points in the convex side of the curve, as in the following diagram. If the curve be such that the tangent,

nt of it, cannot meet it at any other point, the total
 gths of these tangents is less than the length of the
 ve. In this way the length of the curve, though it could
 be exactly determined, might at any rate be ascertained
 be less than one, and greater than another, of two quan-
 'tities; which might be made to differ by a quantity less and

1. *A*
 arc
 cur
 cor
 Ca

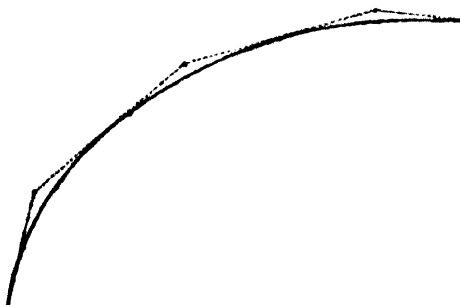

ever, as the number of chords and tangents was increased.
 that the error of the approximation would be determined
 within closer and closer extremes, as the geometer expended
 more and more labour on the mensuration. It is clear,
 however, that the length of the curve has some *exact* value,
 which is the LIMIT of the operations above explained; and
 the discovery of that exact limit is the solution of a problem
 in the Integral Calculus.

7. Again, the area of any plane curvilinear figure is certainly
 greater than that of any polygon of straight sides inscribed
 in it, and less than that of any such polygon circumscribed.
 By increasing the numbers of sides of the circumscribed and
 inscribed polygons, their areas are made to differ less and
 less. The area of the curvilinear figure lying between them
 may thus be determined within any degree of approximation.
 For instance, let the area ACB be included by a curve AB,
 the two straight lines AC, CB, at right angles to each other,
 which requires little science to perceive that one of the readiest
 ways of roughly measuring this area, is to divide it into portions
 nearly as parallel to AC, but not necessarily equidistant, and
 to compute the area of each such portion as if it were a rect-
 angle. Yet this method would give the area of the figure
 not by the curve, but by the zigzag dotted line

INTEGRAL CALCULUS.

within or without the figure. The difference between the rectilinear figures bounded by the two zigzag lines is reduced by increasing the number and diminishing the of the rectangles. Thus the curvilinear area may be det

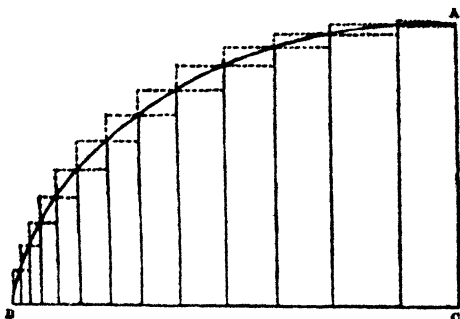

mined within a margin of error which may be diminished at pleasure. This process for determining areas is called the Method of QUADRATURES.

8. It may happen that this method of approximation suggests the limit to which it tends. The Integral Calculus differs from the preceding method only in that it substitutes *absolute exactness* for mere approximation. The curvilinear figure must have some *exact* area which is the *limit* of the results of the above operations. If, therefore, that limit may be inferred from them, they lead to *the solution of a problem of the Integral Calculus*.

9. Again, one of the most frequent problems of Dynamics is to ascertain the distance passed over in a given time by a point moving with continually-varying velocity. If the point were moving with uniform velocity, the distance described by it in any time could be immediately ascertained. The approximation to the distance described by a varying velocity is analogous to the approximations above described, and consists in supposing the velocity to change not continuously but after intervals, and remain uniform during each interval. The shorter the intervals, the more nearly does the distance computed on this supposition approximate to the real distance described. Let the distances be computed on the hypotheses, *first*, that the point retains throughout

each of the intervals into which its motion is hypothetically divided, the velocity it actually has at the commencement of that interval; *secondly*, that the point has throughout each interval the velocity it actually has at the termination of that interval. The first hypothesis evidently gives the distance traversed too small; the second hypothesis too large, if the velocity be a continuously-increasing one. By diminishing the hypothetical intervals, the error of approximation is reduced; and if the limit to which these operations lead can be found, the result is *the solution of a problem of the Integral Calculus*.

10. The principle on which all the above cases depend, may be stated generally thus:—A quantity is to be measured which cannot be immediately compared with the unit of measurement. The quantity is therefore divided into several parts, and it is ascertained of each of these, that it exceeds one, and falls short of another, of two quantities measurable by the given unit. The sums of the two series of measurable quantities are the one greater, the other less, than the whole quantity to be measured.

This process has been continually practised by the most unskilful as well as the most skilful computers. It is applied in innumerable cases in the ordinary avocations of life. The science which from this kind of approximation extracts rigorous and exact truth, is the INTEGRAL CALCULUS.

The foregoing remarks will probably suffice to show the student what kind of reasoning may be expected to engage his attention in this subject. They serve also to render intelligible the following slight sketch of its history.

SECTION II.

EARLY HISTORY OF THE INTEGRAL CALCULUS.

PYTHAGORAS, born about 590 B.C., died about 497 B.C. The history of his mathematical discoveries rests generally on no higher authority than that of tradition. The discovery of the quadrature of the parabola has been ascribed to him, as appears from the following passage in Dr. Hutton's Mathematical Dictionary. In reference to the theorem that the square on the hypotenuse of a right-angled triangle is equal to the sum of the squares on the sides, it is remarked, that "Plutarch even doubts whether such a sacrifice was made for the said theorem, or even for the area of the Parabola, which it was said Pythagoras also found out."

EUCLID, who lived about 280 B.C., and about 50 years before Archimedes, showed, in his 10th Book, that the areas of the Circle and Polygon inscribed in it are ultimately equal. He demonstrated that the area of the circle is equal to half the rectangle contained by the radius and circumference, and thus found out a problem of Integration. His method is known as the method of *Exhaustions*. The first proposition of the 10th Book asserts that, if from the greater of two given quantities be taken more than its half, from the resulting remainder more than its half, and so on continually, there will remain at last a quantity less than either of the given quantities. By this reasoning, the difference between the circle and polygon is exhausted, and the circle becomes ultimately equal to the polygon.

ARCHIMEDES, who lived about 250 B.C., investigated the ratio of the circumference of a circle to its diameter. By calculating the length of the periphery of a circumscribed polygon of 192 sides, and an inscribed polygon of 96 sides, he found that the circumference of the circle is between $3\frac{1}{8}$ and $3\frac{1}{4}$ of the diameter. He left a treatise on the Spiral which now bears his name; and determined the relation of the area bounded by that curve to that of the circumscribed circle. To Archimedes is attributed the quadra-

ture of the parabola, which discovery, however, as appears above, has been assigned to Pythagoras also. Let AO be a portion of a parabola, O its vertex, OB a part of its axis, and AB a straight line at right angles to it. The proposition in question, which is interesting from its antiquity and intrinsic importance, asserts that the area AOB is two-thirds of the rectangle $ACOB$. The student may easily ascertain after reading the following

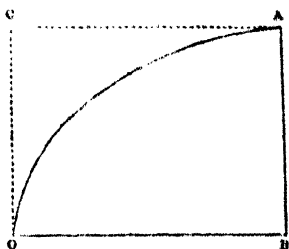

pages, that this result is equivalent to the integration of a function of the form cx^2 , where c is constant and x variable.

Archimedes showed in his treatise *Περὶ Σφαιρας καὶ κυλίνδρου*, that the content of a sphere is two-thirds of that of the cylinder which just contains it; that the surface of a sphere is four times as great as that of one of its great circles, &c.

CONON, a contemporary of Archimedes, is said to have invented the spiral which bears the name of the latter, and to have proposed to him problems respecting it, which were solved by him.

PAPPUS, who lived towards the end of the fourth century (about A.D. 380), demonstrated some of the principal properties of the same spiral, by adding together an indefinite number of parallelograms and cylinders, into which he supposed a triangle and cone ultimately divided. Pappus also gave in the preface to his 7th Book, the *centrobaric* method of determining the content and superficies of a solid of revolution in terms of the dimensions of the generating figure, and the position of its centre of gravity. The theorems of the *centrobaric* method discovered by Pappus, frequently are called *Guldin's properties*, from a much later mathematician, *Guldini*, by whom they were demonstrated.

GALILEO, born 1564, died 1642, proved that a body moving in a straight line with a constant acceleration, such as that produced by gravity, describes in any time from the commencement of the motion a distance proportional to that time. He thence showed that the path of a projectile is a parabola. The determination of the distance described by a

constantly-accelerated point depends necessarily on the principles of the Integral Calculus, as explained in Article 9.

TORRICELLI, born 1608, died 1647, was a disciple of Galileo, and wrote a treatise *De Dimensione Parabolæ*, with an appendix *De Dimensione Cycloidis*. Dr. Hutton says, that Torricelli "first shewed that the cycloidal space is equal to triple the generating circle (though Pascal contends that Roberval shewed this); also, that the solid generated by the rotation of that space about its base, is to the circumscribing cylinder as 5 to 8; about the tangent parallel to the base, as 7 to 8; about the tangent parallel to the axis, as 3 to 4," &c. (See DESCARTES.)

CAVALIERI, a disciple of Galileo, and friend of Torricelli, published in 1635, *Geometria Indivisibilibus continuorum novâ quâdam ratione promotâ*, 4to., Bononiæ. This work, which obtained for the author the credit in Italy of inventing the Infinitesimal Calculus, proceeds by division of geometrical figures into indefinitely small parts.

ROBERVAL, in 1646, determined the centres of percussion and centres of gravity of sectors of cylinders and circles, &c., by methods equivalent to Integration. From the letters of Descartes, it appears that these discoveries were subjects of controversy between him and Roberval. Roberval's Treatise on Indivisibles, appeared in 1666, in the Memoirs of the Academy of Sciences at Paris.

DESCARTES, born 1596, died 1650, determined the centres of gravity and centres of oscillation of various curvilinear figures. His method of demonstrating the proposition respecting the cycloid, referred to in the preceding notice of Torricelli, is an excellent instance of the geometrical investigation of the quadrature of curves. The following is an extract from a letter from him to Father Mersenne, in 1638. (*Lettres de Descartes*, tome iii. page 384, Paris, 1667.)

"You commence by an invention of Monsieur de Roberval, respecting the space included by the curve described by a point of the circumference of a circle supposed to roll on a plane; with respect to which, I acknowledge that I have never before thought of it, and that the observation of it is pretty enough. But I do not see that there is reason to make so much noise at having found a thing which is so easy, and which any one who knew ever so little of geometry could not fail to find if he sought for it. For if ADC be

this curve, and AC a straight line equal to the circumference of the circle STVX, having divided this line AC into 2, 4, 8, &c., equal parts, by the points B, G, H, N, O, P, Q, &c., it

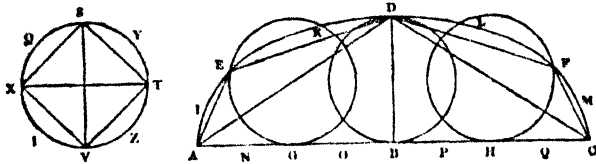

is evident that the perpendicular BD is equal to the diameter of the circle, and that the whole area of the rectilinear triangle ADC is double of this circle*. Then, taking E for the point where the same circle would touch the curve AED, if it were placed on its base at the point G, and taking also F for the point where it touches this curve, when it is placed on the point H of its base, it is evident that the two rectilinear triangles AED and DFC are equal to the square STVX inscribed in the circle. Similarly, taking the points I, K, L, M for those where the circle touches the curve when it touches its base at the points N, O, P, Q, it is evident that the four triangles AIE, EKD, DLF, and FMC are together equal to the four isosceles triangles inscribed in the circle SYT, TZV, VIX, and XQS; and that the eight other triangles inscribed in the curve on the sides of these four are equal to the eight inscribed in the circle, and so on to infinity; whence it appears that the whole area of the two segments of the curve, which have AD and DC for bases, is equal to that of the circle; and, consequently, the whole area contained between the curve ADC and the straight line AC, is triple that of the circle."

GREGORY (St. Vincent) of Bruges, published in 1647, *Opus Geometricum Quadraturæ Circuli et Sectionum Coni*. He showed that the space between a hyperbola and its asymptote is divided into equal portions by straight lines, which divide the asymptote into parts in geometrical progression, and which are parallel to the other asymptote.

FERMAT, who died 1663, was author of a "Method for Quadrature of all sorts of Parabolas," and a treatise on

* By a property of the circle mentioned in the notice of Euclid.

Maxima and Minima, in which problems concerning the centres of gravity of solids are solved by a method resembling Newton's Fluxions.

HUYGENS, in 1651, published *Theoremata de Quadraturâ Hyperbolæ, Ellipsis et Circuli ex dato Portionum Gravitatis Centro*; and in 1658, at the Hague, his celebrated *Horologium Oscillatorium sive de motu Pendulorum*, in which he states that he was the first discoverer that a certain segment of the cycloid is equal to a regular hexagon inscribed in the generating circle. He showed that the time of oscillation of the cycloidal pendulum is independent of the extent of vibration, and from the principles of the pendulum measured the effect of gravity, by which he showed that a body descended vertically from rest in vacuo, in the latitude of Paris, 15 French feet in one second.

WALLIS, in 1655, published his *Arithmetica Infinitorum*, a great improvement on the Indivisibles of Cavalieri. Wallis treats of quadratures, and gives the first expression for the quadrature of a circle by an infinite series in this work, "in which," says Professor De Morgan, "a large number of problems of the Integral Calculus is solved, and which contained more hints for future discovery than any other work of its day."

NEAL, in 1657, made a remarkable step in the Integral Calculus. He appears to have been the first person who determined the exact length of any curve. Wallis, in his *Treatise on the Cissoid*, states that Neal's rectification of the semi-cubical parabola was published in July or August, 1657.

VAN HAURENT, in Holland, in 1659, also gave the rectification of the semi-cubical parabola, as appears from Schooten's *Commentary on Descartes' Geometry*.

GREGORY (JAMES) published, in 1667, *Vera Circuli et Hyperbolæ Quadratura*, to which he added in the year following *Geometrica Pars Universalis*, of which the method resembles that of Roberval's Indivisibles.

Dr. BARROW, in 1670, published his *Method of Tangents*. He died in 1677, and the year following appeared his demonstrations of Archimedes' properties of the Sphere and Cylinder, by the method of Indivisibles.

LEIBNITZ, in 1684, gave in the *Leipsic Transactions* an account of his Differential Calculus. It is agreed that this was the first time that this grand discovery appeared in *print*; though in the celebrated controversy which arose as to his

claim to the priority of this invention, a Committee of the Royal Society decided that "Sir I. Newton had even invented his method before 1669." The general opinion of modern mathematicians appears to concede to Leibnitz the merit of an independent discovery, and to exempt him from the charge of plagiarism.

GREGORY (DAVID) published, in 1684, *Exercitatio Geometrica de Dimensione Figurarum*.

NEWTON published his *Principia* in 1687, the most memorable year, therefore, in the annals of science. The doctrine of limits, conceived and applied in the earliest periods of mathematical research, had been rapidly growing in importance at the time of Newton and Leibnitz. The great step made by them consisted in connecting the idea of limits with a specific notation, and in erecting into a regular system a science which before their time had been exhibited only in isolated theorems. A large part of the results of the *Principia* are demonstrated by geometrical methods equivalent to Integration. Newton's Method of Fluxions was first published in 1704, subjoined to his treatise on Optics.

MERCATOR (NICHOLAS), in 1688, published his *Logarithmotechnia*, and is stated to have been the first person who ever investigated the quadrature of curves *analytically*. This he did in a Demonstration of Lord Brouncker's Quadrature of the Hyperbola, by Wallis's method of reducing an algebraical fraction to an infinite series by division.

By the English contemporaries of Newton, the Integral Calculus, a Differential Coefficient, and an Integral, were called the Inverse Method of Fluxions, a Fluxion, and a Fluent respectively. The notation and phraseology of fluxions is now almost obsolete. The methods of Exhaustions, Primo and Ultimate Ratios, Infinitesimals, Indivisibles, Residual Analysis, Analysis of Derivations or Derived Functions, and of Limits, are different appellations which the same subject has at different times received.

From the time of Newton and Leibnitz the Integral Calculus rapidly advanced. Its progress was in a great degree due to John and James Bernouilli, who published a large number of memoirs on the subject; to Maclaurin, whose Fluxions appeared in 1742; to Cotes, whose *Harmonia Mensurarum* appeared in 1722; to D'Alembert, who gave Memoirs on the Calculus in the Paris and Berlin Memoirs; and to

Euler's great work, *Institutio Calculi Integralis*. Petr. 1768, 8 vols. 4to.

The analytical part of the Integral Calculus consists in reducing integrals to forms by which their numerical values may be computed. This computation is usually facilitated by the common mathematical tables of sines, cosines, logarithms, &c. But many integrals cannot be found by these tables. In order to compute such integrals, other tables have been constructed, of which the principal are called Tables of *Elliptic Integrals*, from their relation to the length of elliptic arcs.

FAGNANO, in his *Produzione Matematiche*, 1750, investigated a remarkable theorem respecting these arcs, which bears his name, and shows how the length of two arcs may be taken so as to differ by an assigned algebraical quantity.

EULER gave to the world some of the most important discoveries which constitute the basis of this branch of the Integral Calculus. In 1761 he published, in the Petersburg Transactions, the complete integration of an equation involving two terms, each an elliptic function not separately integrable. Euler also invented the class of integrals which are known as Eulerian Integrals.

LANDEN, in 1775, published his theorem showing that any arc of a hyperbola may be measured by two arcs of an ellipse.

LAGRANGE'S Memoirs in the Turin Transactions, in 1784 and 1785, greatly extended the subject of elliptic functions in a part of it which Euler had not discussed, and rendered the determination of numerical values of elliptic functions very complete.

LEGENDRE undertook the task, involving immense labour, of computing a greatly-extended series of tables. The second volume of Legendre's great treatise on elliptic functions, to which a large part of his life had been devoted, appeared in 1827. To him is attributed the merit of giving to the subject that systematic arrangement and connection which constitute it a separate science.

JACOBI, Professor of Mathematics in Koningsburg, published shortly afterwards, in Schumacher's Journal, his researches on elliptic functions. His principal object was the investigation of certain general relations of these functions, of which the investigations of Lagrange and Legendre involve particular cases.

ABEL, Professor of Mathematics in Christiania, gave investigations of the subject in Crelle's Journal, in 1827. He arrived independently at many of the important discoveries of Jacobi, and contributed valuable theorems respecting what are called ultra-elliptic functions. The works of Abel, who died at the early age of 27 years, are esteemed among the most important contributions to modern analysis.

For some account of modern discoveries in Calculus, the reader may be referred to Moigno's edition of Cauchy's *Leçons de Calcul Différentiel et de Calcul Integral*, 1844.

Among the best known general works on the Integral Calculus are the following:—

- Bossut, *Cal. Diff. et Integral*. Paris, 1798.
 Boucharlat, *Differential and Integral Calculus*, Eng. Translation. Cambridge, 1828.
 Carnot, *Metaphysique de Calcul Infinitesimal*. Paris, 1796.
 Cauchy, *Leçons de Cal. Diff. et Int.* Vol. 2, *Calcul Integral*. Paris, 1844.
 Condorcet, *Calcul Integral*. Paris, 1765.
 Cournot, *Des Fonctions et du Calcul Infinitesimal*. Paris, 1841.
 De Morgan's *Diff. and Integral Calculus*. London, 1842.
 Duhamel, *Cours d'Analyse*. Paris, 1847.
 Euler, *Institutiones Calculi Integralis*. Petersburg, 1792.
 Gregory's *Examples on the Diff. and Int. Cal.* Cambridge.
 Hirsch, *Integraltafeln*. Berlin, 1810.
 Lacroix, *Calcul Diff. et Integral*. Paris, 1797.
 Lagrange, *Leçons sur le Calcul de Fonctions*. Paris, 1806.
 Landen's *Residual Analysis*. London, 1758.
 Legendre, *Exercices du Calcul Integral*. Paris, 1816.
 ———— *Traité de Fonctions Elliptiques*, 1825-8.
 Littrow, *Anleitung zur höheren Mathematik*. Vienna, 1836.
 Mending's *Tables of Integrals*.
 Ohm (Martin), *System der Mathematik*, 1833-51.
 Raabe, *Die Differential und Integral Rechnung mit Functionen Mehrerer Variabeln*.
 Schlömilch, *Handbuch der Differenzial Rechnung*, 1847.
 Taylor, *Methodus Incrementorum*. London, 1715.

SECTION III.

DEFINITIONS.—GENERAL PRINCIPLES OF INTEGRATION.

11. QUANTITIES are said to be *functions* of one another, if their values depend in any manner on each other. The letters F, f, ϕ , &c., prefixed to quantities, are used to denote functions of them. A function of several quantities is expressed by writing the letters F, f , &c., before them all separated by commas.

12. A *variable* is a symbol of quantity to which different values may be assigned.

13. An *independent variable* is a symbol of quantity, on the value of which the value of a function of it is considered dependent.

14. A *limit* is the exact value which a function approaches nearest, as the variables on which it depends approach assigned values.

15. *The limit of a finite continuous function of several quantities is the same function of their limits*, or if $y_1, y_2, y_3 \dots$ be the limits of $y_1, y_2, y_3 \dots$ respectively,

limit of

where f means "any finite continuous function of."

A *continuous function* is one such that the series of operations denoted by it when performed on more and more nearly equal quantities, produce more and more nearly equal results;

$$f(y_1, y_2, y_3 \dots) - f(y_1, y_2, y_3 \dots) \dots\dots (2),$$

is smaller, as y_1, y_2, y_3 , &c., are more and more nearly equal to y_1, y_2, y_3 , &c., respectively. Therefore, the limit of the finite quantity (2) is zero, or

limit of $f\{(y_1, y_2, y_3 \dots) - f(y_1, y_2, y_3 \dots)\} = 0$,

from which equation (1) immediately follows.

16. The *quadrature* of a finite continuous function of one variable having a limited range of values is the sum of products of successive values of that function, each multiplied by the differences between the corresponding value of the independent variable and the next preceding or succeeding value.

17. The *integral* of such a function is the limit which its quadrature has when the differences of the independent variable approach zero, and their number approaches infinity.

18. Let $f x$ denote a finite continuous function of x , and let b_1 and b_2 be two constant assigned values of x . Also, let $x_1, x_2, x_3 \dots x_n$ be any successive intermediate variable values of x . Then the quadrature of $f x$ is by the definition, either

or $f b_1(x_1 - b_1) + f x_1(x_2 - x_1) + f x_2(x_3 - x_2) + \dots + f x_n(b_2 - x_n)$.

The integral of the function is the limit which these series approach when the differences $x_1 - b_1, x_2 - x_1, \&c.$, approach zero, and their number infinity.

19. In Art. 7, let x be the abscissa, measured from B along BC of any point in the curve BA, and let $f x$ denote the corresponding abscissa. Then it is clear that the differences $x_1 - b_1, x_2 - x_1, \&c.$, denote the breadth of the rectangles drawn in the figure, and $f x_1, f x_2, \&c.$, the corresponding altitudes. Hence, the several terms in the foregoing series denote the areas of those rectangles, and their sum is an approximation to the curvilinear area ABC, whence the term quadrature is derived, since that quantity expresses approximately the number of *square* units (square feet, square yards, &c.) contained in ABC. Also, the integral is the exact area ABC; for the magnitude of this area is between the magnitudes of the inscribed and circumscribed figures. But the difference between the two latter magnitudes has the limit zero. A fortiori, the curvilinear area differs from either of them, by a magnitude which has the limit zero.

As the figure last referred to is drawn, the initial values of x and of $f x$ are both supposed to be zero. If, however, they be finite positive quantities, the integral represents an area such as $abcd$, where o is the origin from which the abscissæ are drawn, and

$$\begin{aligned} oc &= b_1, & bc &= f b_1, \\ &= b_2, & \text{and } od &= f b_2. \end{aligned}$$

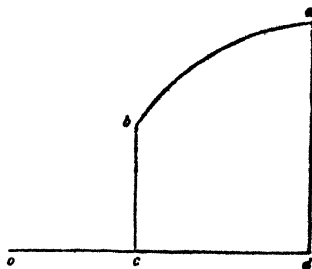

20. Both expressions for the quadrature in Article 18 have the same limit, if $f x$ have only one finite value for each value of x from b_1 to b_2 , for then they differ by the quantity

$$\begin{aligned} &(f x_1 - f b_1)(x_1 - b_1) + (f x_2 - f x_1)(x_2 - x_1) + \\ &(f x_3 - f x_2)(x_3 - x_2) + \dots + (f b_2 - f x_n)(b_2 - x_n). \end{aligned}$$

Let Δx be the greatest of the successive differences of x in the preceding quantity, which is therefore less than

$$(f x_1 - f b) \Delta x + (f x_2 - f x_1) \Delta x + \dots + (f b_2 - f x_n) \Delta x,$$

which expression is equal to $(f b_2 - f b_1) \Delta x$. This, therefore, is the difference between the two quadratures; but if $f b_2$ and $f b_1$ be finite, $f b_2 - f b_1$ is finite; Δx is zero in the limit. Therefore, the difference between the two quadratures is zero in the limit, i. e., they have the same limit.

21. The preceding article is exactly illustrated by the Lemma iii. of Newton's Principia, which is as follows (supposing all the parallelograms spoken of in the original to be rectangles):—

In the plane figure bounded by the curve AF and straight lines AA' , AF , at right angles to each other, are inscribed any number of rectangles AB' , BC' , CD' ... on unequal bases AB , BC , CD ..., and the rectangles AB'' , BC'' , CD'' ... are completed. If the breadth of these rectangles be diminished, and their number increased indefinitely, the in-

scribed figure $AKB'L'CM'D'NE'E$, and the circumscribed figure $AA'B''B'C''C'D''D'E''EF$ are ultimately equal. For let Af be equal to the greatest breadth of the rectangles, and complete the rectangle Af' , then this parallelogram will be greater than the difference between the inscribed and the circumscribed figures. But when its breadth is diminished, it will be less than any assignable quantity, and, therefore, à fortiori, the difference between the inscribed and circumscribed figures will be less than any assignable quantity, and, therefore, they are ultimately equal.

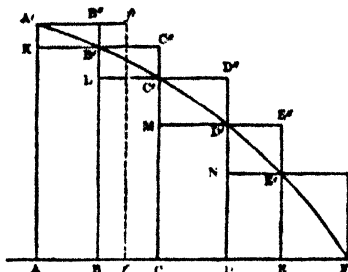

22. When fx continually increases or continually decreases, as x increases, the value of the integral is between those of its quadratures. First, let fx continually increase as x increases, then the integral is less than the first quadrature, Art. 18; for let x' and x'' be any two successive values of x , then one of the terms of this quadrature is $f x''(x'' - x')$.

Now, take a value x_1 between x' and x'' , then the term in question is replaced by

$$f x_1(x_1 - x') + f x''(x'' - x_1),$$

which is less than the term just mentioned by

$$(f x'' - f x_1)(x_1 - x'),$$

a quantity which is positive, since $f x''$ is always greater than $f x_1$; therefore, the effect of increasing the number of terms is to diminish the quadrature. But as the number of terms is increased, the value of the integral is more and more nearly approached; therefore, the integral is less than the first quadrature.

Similarly may it be shown that the integral is greater than the second quadrature.

The same reasoning may be applied when the function fx continually decreases as x increases; therefore, in either case, the integral has a value between those of its quadratures.

23. *The symbol of integration is \int , which derives its form from the initial letter of the word *Summa*, or *sum*. The integral of a function $f x$ of a variable x is written $\int f x . dx$; where the limit of the difference between two successive values of x is represented by dx , which is, therefore, *differential*, or diminished without limit; and $f x . dx$ is the general form of the limit of any term of the series in Art. 7, and is also differential.*

24. *The limits of an integral are the two constant assigned values of the independent variable b_1 and b_2 , in Art. 7. The greater and less of these values are frequently designated the superior and inferior limit respectively.*

25. When the limits of an integral are expressed, or defined, it is said to be *definite*; when they are not defined, *indefinite*. In the first case, the integral is said to be *taken between limits*. The usual way of expressing this symbolically is, by writing the superior limit above, and the inferior below, the symbol of integration. Thus, $\int_{b_1}^{b_2} f x . dx$ is the integral of $f x$, between limits b_1 and b_2 .

26. *The value of the integral is independent of the differences of the independent variable in the quadrature.* For the limit of the quadrature is, by Art 14, an exact quantity, therefore it cannot depend on the values $x_1, x_2, x_3, \dots x_n$, nor their differences, which may be altered arbitrarily. Also, it is evident that the integral does not involve any other values of x , except b_1 and b_2 .

COROLLARY. Hence $\int_{b_1}^{b_2} f x dx = \int_{b_1}^{b_2} f z dx$, where z is any other quantity than x .

27. *The sum of definite integrals, the inferior limit of each being the superior limit of the next.* If the series in Art. 18 were continued to the right, to the term in which $x = b_2$, the limit of this additional part of the series would, by the preceding definitions, be $\int_{b_1}^{b_2} f x . dx$. Also, the limit of the whole series, including the additional part, would be $\int_{b_1}^{b_2} f x . dx$. But this whole series is the sum of that written in Art. 18, + the supposed additional part. Hence,

$$\int_{b_1}^{b_2} f x \, dx = \int_{b_1}^{b_2} f x \, dx + \int_{b_1}^{b_2} f x \, dx \dots \dots \dots (1)$$

Similarly,

$$\int_{b_1}^{b_n} f x \, dx = \int_{b_{n-1}}^{b_n} f x \cdot dx + \int_{b_{n-2}}^{b_{n-1}} f x \cdot dx + \dots + \int_{b_2}^{b_3} f x \cdot dx + \int_{b_1}^{b_2} f x \cdot dx.$$

28. An Integral between limits is the difference between two values of the same function. By Art. 26, $\int_{b_1}^{b_2} f x \, dx$ is independent of all the values of x , except b_2 and b_1 . Therefore this integral may be put equal to $F(b_2, b_1)$, some function which contains no value of x except b_1 and b_2 . Similarly, if the form of this function be general, that is, capable of representing the integral for all values of the limits, $\int_{b_1}^{b_2} f x \, dx = F(b_2, b_1)$. Hence, from (1) Art. 27, transposing,

$$\int_{b_2}^{b_3} f x \cdot dx = F(b_3, b_1) - F(b_2, b_1);$$

but $\int_{b_2}^{b_3} f x \cdot dx$ involves no other value of x than b_3 and b_2 . Therefore b_1 disappears from the last equation, which, consequently, may be written

$$\int_{b_2}^{b_3} f x \cdot dx = F b_3 - F b_2;$$

COROLLARY, $\int_{b_2}^{b_3} f x \, dx = - \int_{b_3}^{b_2} f x \, dx.$

29. By Article 26, the value of the integral is independent of the differences $x_1 - b_1$, $x_2 - x_1$, &c., in Art. 18. We may therefore suppose those differences all = δx , so that $(n + 1) \delta x = b_2 - b_1$. Then, by Art. 28,

$$\text{limit of } (f x_1 + f x_2 + f x_3 + \dots + f x_n + f b_2) \delta x = F b_2 - F b_1.$$

The number of terms in the parenthesis is $n + 1$. Now suppose, first, that the $f x$ is always positive; and let $f a'$ be its greatest, $f a''$ its least value between the limits;

then $f x'$ is greater and $f x''$ less than any other of the terms in the parenthesis. Hence $(n+1)f x'$ is greater, and $(n+1)f x''$ is less than their sum;

$$\therefore (n+1)f x' \cdot \delta x > F b - F b_1; \quad (n+1)f x'' \delta x < F b_2 - F b_1;$$

$$\text{or, putting } (n+1)\delta x = h; \quad h f x' > F b_2 - F b_1;$$

$$h f x'' < F b_2 - F b_1.$$

There must therefore be one or more values of x between x_1 and b_2 , for which $h f x = F b_2 - F b_1$. But this intermediate value of x must also be between b_1 and b_2 , since x_1 may be taken as near b_1 as we please. Therefore the intermediate value in question may be expressed by $b_1 + \theta h$, where θ is some positive proper fraction. Hence, since we have supposed $b_2 = b_1 + h$, we have the formula

$$h f(b_1 + \theta h) = F(b_1 + h) - F b_1 = \int_{b_1}^{b_1+h} f x \cdot dx$$

The same conclusion would be arrived at if $f x$ were supposed to be always negative. Hence the formula is true when $f x$ is either always positive or always negative between the limits b_1 and $b_1 + h$.

30. The following is a geometrical illustration of the formula $h f(b_1 + \theta h) =$

$$\int_{b_1}^{b_1+h} f x \cdot dx.$$

Let $f x$ represent, as in Art. 19, the ordinates of the curve ab , and x its abscissa, measured from o along od ; $oc = b_1$, $od = b_1 + h$; $\therefore cd = h$. Also $bc = f b_1$; $ad = f(b_1 + h)$. Then the

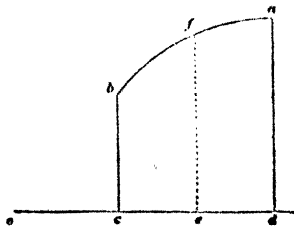

area $abcd = \int_{b_1}^{b_1+h} f x \cdot dx$. Now the formula asserts that

between bc and ad there is some intermediate ordinate represented by fe in the figure, and by $f(b_1 + \theta h)$ in the formula, such that $fe \times cd = \text{area } abcd$, a proposition which, from geometrical considerations, is evidently true.

31. *A Function is the differential coefficient of its Integral*
 Dividing by h , the result in Article 29,

$$f(b_1 + \theta h) = \frac{F(b_1 + h) - Fb_1}{h}.$$

Taking the limit of both sides of this equation, when h has the limit zero,

$$fb_1 = \text{differential coefficient of } Fb_1,$$

by the definition of a differential coefficient. Hence is seen that INTEGRATION IS THE OPERATION INVERSE OF DIFFERENTIATION.

32. *The integral of the sum of several functions between given limits = the sum of the integrals of the several functions between the same limits.* Let the several functions be $f_1x, f_2x, \dots f_nx,$

$$\int_{b_1}^{b_2} f_1x dx = \text{limit of } (f_1x_1 + f_1x_2 + f_1x_3 + \dots f_1b_2) \delta x$$

$$\int_{b_1}^{b_2} f_2x dx = \text{limit of } (f_2x_1 + f_2x_2 + f_2x_3 + \dots f_2b_2) \delta x$$

.....

$$\int_{b_1}^{b_2} f_nx dx = \text{limit of } (f_nx_1 + f_nx_2 + f_nx_3 + \dots f_nb_2) \delta x$$

Adding. $\int_{b_1}^{b_2} f_1x dx + \int_{b_1}^{b_2} f_2x dx + \dots + \int_{b_1}^{b_2} f_nx dx =$

limit of $\{(f_1x_1 + f_2x_1 + \dots + f_nx_1) + (f_1x_2 + f_2x_2 + \dots + f_nx_2) +$
 $\&c. + (f_1x_n + f_2x_n + \dots + f_nx_n)\} \delta x =$

$$\int_{b_1}^{b_2} (f_1x + f_2x + \dots + f_nx) dx.$$

33. *A constant multiplied by the integral of function between given limits = the integral of the function multiplied by the constant between the same limits.* Let c be the constant. Then

$$\begin{aligned}
 c \int_{b_1}^{b_2} f x \, dx &= c \text{ limit } (f x_1 + f x_2 + f x_3 + \dots + f b_2) \delta x \\
 &= (\text{by Art. 15}) \text{ limit of } (c f x_1 + c f x_2 + c f x_3 + \dots + c f b_2) \delta x \\
 &= \int_{b_1}^{b_2} c f x \, dx.
 \end{aligned}$$

34. To show that $\int_{b_1}^{b_2} y \, dx + \int_{c_1}^{c_2} u \, dy = b_2 c_2 - b_1 c_1$, if y be a function of u , and have the values c_1, c_2 , when u has the values b_1, b_2 , respectively. $y_1, y_2, y_3 \dots y_n$ being successive values of the function y and $u_1, u_2 \dots u_n$ of u , we have, by Art. 18,

$$\int_{b_1}^{b_2} y \, du = \text{limit of } \{c_1(u_1 - b_1) + y_1(u_2 - u_1) + y_2(u_3 - u_2) + \dots + y_n(b_2 - u_n)\}$$

$$\int_{c_1}^{c_2} u \, dy = \text{limit of } \{u_1(y_1 - c_1) +$$

$$u_2(y_2 - y_1) + \dots + u_n(y_n - y_{n-1}) + b_2(c_2 - y_n)\}.$$

By adding together the quantities in the $\{ \}$, it will be found that all in each line except one appear in the other line with contrary signs. So that the sum in question is reduced to $b_2 c_2 - b_1 c_1$. Hence

$$\int_{b_1}^{b_2} y \, du + \int_{c_1}^{c_2} u \, dy = b_2 c_2 - b_1 c_1.$$

35. The conclusion of Art. 34 may be arrived at from geometrical considerations, as follows:

Let AB be a curve referred to, Ox, Oy as axes of co-ordinates. Let $OC = b_1, OD = b_2$. Then the area $ABCD =$

$$\int_{b_1}^{b_2} y \, dx.$$

In the same way, if $OE = c_1, OF = c_2$, the

$$\text{area } ABEF = \int_{c_1}^{c_2} x \, dy.$$

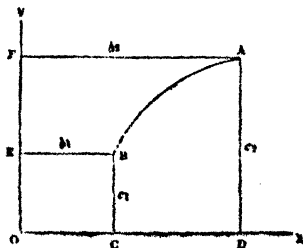

Therefore $\int_{b_1}^{b_2} y \, dx + \int_{c_1}^{c_2} x \, dy = \text{figure AFEBCD} =$
 rectangle AO — rectangle BO $= b_2 c_2 - b_1 c_1$.

36. To determine $\int dx$. In the first equation, Art. 29, it is not necessary that fx should be variable. Let it = 1.

Then limit of $(\delta x + \delta x + \dots + \delta x) = \int_{b_1}^{b_2} dx$.

But, evidently, the left-hand side of this equation = $b_2 - b_1$,

$$\therefore b_2 - b_1 = \int_{b_1}^{b_2} dx.$$

37. If x and y be functions of each other, so that

$$\int_b^x f x \, dx = \int_c^y \phi y \, dy \quad (1), \text{ and } x = b \text{ when } y = c,$$

$$\text{then } f x \, dx = \phi y \, dy.$$

For let (Art. 28) the first of these integrals = $Fx - Fb$, and the second = $\Phi y - \Phi c$. Then

$$Fx - Fb = \Phi y - \Phi c.$$

Let x become $x + \delta x$ when y becomes $y + \delta y$. Then

$$F(x + \delta x) - Fb = \Phi(y + \delta y) - \Phi c.$$

Subtracting the last equation from this,

$$F(x + \delta x) - Fx = \Phi(y + \delta y) - \Phi y,$$

$$\text{or } \frac{F(x + \delta x) - Fx}{\delta x} = \frac{\Phi(y + \delta y) - \Phi y}{\delta y} \cdot \frac{\delta y}{\delta x} \dots (\alpha).$$

Now this equation is true, however small δx and δy may be; therefore, the limits of both sides (corresponding to the limit zero of δx and δy) are equal; or, by Art. 17,

$$f x = \phi y \frac{dy}{dx}, \text{ or } f x \frac{dx}{dy} = \phi y \dots \dots \dots (\beta),$$

whence, $f x \, dx = \phi y \, dy$.

38. To prove that if $fx dx = \phi y dy$, and x be equal to b_2 and b_1 when y is equal to c_2 and c_1 respectively, then

$$\int_{b_1}^{b_2} fx dx = \int_{c_1}^{c_2} \phi y dy.$$

For let $\int_{b_1}^{b_2} fx dx = \int_{c_1}^{c_2} \phi y dy + \int_{c_1}^{c_2} \phi_1 y dy,$

then, by the last proposition, $fx = \phi y + \phi_1 y.$

But by the hypothesis $fx = \phi y,$

$$\therefore \phi_1 y = 0, \quad \therefore \int_{c_1}^{c_2} \phi_1 y dy = 0,$$

for this last integral is the limit of the sum of a series of which the terms are all absolutely zero;

$$\therefore \int_{b_1}^{b_2} fx dx = \int_{c_1}^{c_2} \phi y dy = \int_{c_1}^{c_2} \left(fx \frac{dx}{dy} \right) dy; \text{ by } (\beta).$$

39. From the preceding article follow many important relations among definite integrals. For instance, let $y + a = x$; then $c_2 + a = b_2, c_1 + a = b_1, dy = dx; \therefore fx = \phi y = f(y - a),$ and the formula becomes

$$\int_{b_1}^{b_2} f(y - a) dy = \int_{c_1}^{c_2} \phi y dy = \int_{b_1 - a}^{b_2 - a} fx dx.$$

Now in the first of these integrals we may, by the Corollary, Art. 20, write y for $x.$ Therefore

$$\int_{b_1}^{b_2} f(x - a) dx = \int_{b_1 - a}^{b_2 - a} fx dx \dots\dots\dots (I.)$$

Similarly,

$$\int_{b_1}^{b_2} f(x + a) dx = \int_{b_1 + a}^{b_2 + a} fx dx \dots\dots\dots (II.)$$

$$\int_0^{b_2 - b_1} f(b_2 - x) dx = \int_{b_1}^{b_2} fx dx \dots\dots\dots (III.)$$

Putting $y - a = s$ and $b_2 - y = x$ successively.

Putting $y = -x$; $\int_{b_1}^{b_2} f x dx = \int_{-b_2}^{-b_1} f(-x) dx \dots$ (IV.)

And generally, if $x = \psi y$, whence $y = \uparrow x$, $dx = \psi' y dy$,

$$\int_{b_1}^{b_2} f x dx = \int_{\uparrow b_1}^{\uparrow b_2} f(\psi x) \psi' x dx \dots\dots\dots$$
 (V.)

40. *Indefinite Integration.* We have shown that if function can be integrated between any limits a and b , its independent variable, the integral is of the form $F(a) - F(b)$. There is a large class of functions which cannot be thus integrated between *all* limits, or of which the *general integral* cannot be found. The first part, however, of the science of integration, is confined to the investigation of *general integrals*. Our object is, therefore, to find the *form* of the function F , which represents the result of the integration of the function f . It is not necessary for this purpose to find $Fa - Fb$, but, simply, Fx , from which $Fa - Fb$ may be found by substituting a and b successively for x , and subtracting. In the following chapter, therefore, Fx alone is required.

COROLLARY. It follows that the formula of Art 34 may be written

$$\int y du + \int u dy = uy, \text{ or } \int y du = uy - \int u dy.$$

41. *Differentiation of Integrals.*

From (a) and (β), Art. 37, it follows that

$$\frac{d}{dx} \int_b^x f x dx = f x = \int \frac{d}{dx} f x dx; \text{ or, writing } a \text{ for } x,$$

$$\frac{d}{da} \int_b^a f a da = f a; \text{ or, by corollary (Art. 26),}$$

$$\frac{d}{da} \int_b^a f x dx = f a. \text{ Also,}$$

$$\frac{d}{db} \int_b^a f x dx = - \frac{d}{db} \int_a^b f x dx = - f b.$$

From the first of these equations, it appears that the differentiation of an integral may be performed under the sign of integration.

SECTION IV.

FUNDAMENTAL INTEGRALS.

42. To integrate $a^x dx$ where a is a positive finite quantity. By Art. 15, putting $x_1 = b_1 + \delta x$, $x_2 = b_1 + 2\delta x$, &c., $x_n = b_1 + n\delta x$, $b_2 = b_1 + (n+1)\delta x$,

$$\begin{aligned} \int_{b_1}^{b_2} a^x dx &= \text{limit of } (a^{b_1 + \delta x} + a^{b_1 + 2\delta x} + \dots + a^{b_1 + (n+1)\delta x}) \delta x \\ &= \text{limit of } a^{b_1 + \delta x} (1 + a^{\delta x} + a^{2\delta x} + \dots + a^{n\delta x}) \delta x \\ &= \text{limit of } a^{b_1 + \delta x} \frac{a^{(n+1)\delta x} - 1}{a^{\delta x} - 1} \delta x \\ &= \text{limit of } \frac{\delta x}{a^{\delta x} - 1} (a^{b_2 + \delta x} - a^{b_1 + \delta x}) \dots \dots \dots (1.) \end{aligned}$$

Now the quadrature of which the limit is here to be taken is finite, since all the quantities are finite. By Art. 22, the integral of such a function as a^x has a value between those of the two quadratures, from which it may be obtained. But the quadratures evidently may here be finite quantities with the same sign. Therefore, the integral between them is not zero, nor infinite.

It follows that in (1) the limit of $\frac{\delta x}{a^{\delta x} - 1}$ is some exact function of a . Call it A . Then taking the limit of (1)

$$\int_{b_1}^{b_2} a^x dx = A (a^{b_2} - a^{b_1}). \quad \text{Also, } \int a^x dx = A a^x.$$

If A be such a function of a that $A = 1$ when a has some value ϵ ,

$$\int \epsilon^x dx = \epsilon^x.$$

$$\begin{aligned} \text{Also, } \int a^x dx &= \int e^{\log_e a \cdot x} dx = \frac{1}{\log_e a} \int e^{\log_e a \cdot x} d(\log_e a \cdot x) \\ &= \frac{1}{\log_e a} \cdot e^{\log_e a \cdot x} = \frac{a^x}{\log_e a}. \end{aligned}$$

43. To integrate $\frac{dx}{x}$. Let $x = e^y$, and when $y = c, c_1, c_2$, let $x = b, b_1, b_2$, respectively. Then

$$x - b = e^y - e^c,$$

$$\text{but } x - b = \int_b^x dx, \quad \text{and } e^y - e^c = \int_c^y e^y dy,$$

by Art. 36, and the last article respectively. Hence by Art. 37,

$$dx = e^y dy; \quad \therefore \frac{dx}{x} = dy.$$

Therefore, by Art. 38,

$$\int_{b_1}^{b_2} \frac{dx}{x} = \int_{c_1}^{c_2} dy = c_2 - c_1 = \log_e b_2 - \log_e b_1,$$

since if $x = e^y$, $y = \log_e x$. The indefinite integral is

$$\int \frac{dx}{x} = \log_e x.$$

44. To integrate x^a , where a is a finite constant and x variable.

Let $y = x^{a+1}$, or $\log_e y = (a+1) \log_e x$, a having any real value except -1 ; when $y = c$, or c_1 , or c_2 , let $x = b$, or b_1 , or b_2 , respectively. Then

$$\log_e y - \log_e c = (a+1)(\log_e x - \log_e b).$$

$$\text{By the last article, } \log_e y - \log_e c = \int_c^y \frac{dy}{y},$$

$$\text{and } (a+1)(\log_e x - \log_e b) = (a+1) \int_b^x \frac{dx}{x}.$$

Then by Art. 37, $\frac{dy}{y} = (a + 1) \frac{dx}{x}$;

$$\therefore dy = (a + 1) \frac{dx}{x} \cdot x^{a+1}; \quad \therefore \frac{1}{a + 1} dy = dx \cdot x^a.$$

$$\begin{aligned} \text{Hence } \int_{b_1}^{b_2} x^a \cdot dx &= \frac{1}{a + 1} \int_{c_1}^{c_2} dy = \frac{1}{a + 1} (c_2 - c_1) \\ &= \frac{1}{a + 1} (c_2^{a+1} - c_1^{a+1}). \quad \text{Also, } \int x^a dx = \frac{x^{a+1}}{a + 1}. \end{aligned}$$

45. JOHN BERNOULLI's series. By repeated integration by parts, and Arts. 37 and 44, we have,

$$\begin{aligned} \int_0^x X dx &= Xx - \int_0^x x \frac{dX}{dx} dx \\ &= Xx - \frac{x^2}{2} \frac{dX}{dx} + \int_0^x \frac{x^2}{2} \frac{d^2 X}{dx^2} dx \\ &= Xx - \frac{x^2}{2} \frac{dX}{dx} + \frac{x^3}{2 \cdot 3} \frac{d^2 X}{dx^2} - \int_0^x \frac{x^3}{2 \cdot 3} \frac{d^3 X}{dx^3} dx \\ &= \&c. \\ &= Xx - \frac{x^2}{2} \frac{dX}{dx} + \frac{x^3}{2 \cdot 3} \frac{d^2 X}{dx^2} - \dots \pm \int_0^x \frac{x^n}{2 \cdot 3 \cdot 4 \dots n} \frac{d^n X}{dx^n} dx. \end{aligned}$$

On the second side of this equation all the quantities are taken between the required limits x and 0 ; since each is zero for the latter limit; X , $\frac{dX}{dx}$, $\frac{d^2 X}{dx^2}$... being supposed to be always finite.

If the last term of this series become zero when n is sufficiently increased, we have

$$\int_0^x X dx = Xx - \frac{x^2}{2} \frac{dX}{dx} + \frac{x^3}{2 \cdot 3} \frac{d^2 X}{dx^2} - \dots \text{ ad infinitum.}$$

By Art. 29,

$$xf(\theta x) = \int_0^x f x dx. \quad \text{Put } \frac{x^n}{2 \cdot 3 \cdot 4 \dots n} \frac{d^n X}{dx^n} = f x.$$

Hence, a criterion that the last series may be continued ad infinitum, is, that $f(\theta x)$ become zero when n is sufficiently large, or that then $\frac{x^n}{2 \cdot 3 \cdot 4 \dots n} \frac{d^n X}{dx^n} = 0$ for all values of x between the limits x and 0.

46. e is the base of the Napierian logarithms. By Art. 42,

$$\int e^x dx = e^x \dots\dots\dots (1.)$$

$$\therefore \int e^{-x} dx = - \int e^{-x} d(-x) = - e^{-x} \dots\dots (2.)$$

Therefore, in Bernouilli's series (Art. 45), if

$$X = e^{-x}, \quad \frac{dX}{dx} = - e^{-x}, \quad \frac{d^2 X}{dx^2} = e^{-x}, \text{ \&c.}$$

Hence the series becomes

$$\int_0^x e^{-x} dx = \left\{ x + \frac{x^2}{2} + \frac{x^3}{2 \cdot 3} + \dots \right\} \cdot e^{-x}.$$

For all values of x in this series the criterion of Art. 45 is satisfied, so that the series may be continued *ad infinitum*. The first side of the equation by (2) is equal to $- e^{-x}$ taken between limits 0 and x , or $-(e^{-x} - 1)$

$$-(e^{-x} - 1) = \left\{ x + \frac{x^2}{2} + \frac{x^3}{2 \cdot 3} + \dots \right\} \cdot e^{-x}$$

Dividing by e^{-x} , and transferring one term to the second side of the equation

$$e^x = 1 + x + \frac{x^2}{2} + \frac{x^3}{2 \cdot 3} + \dots$$

In this equation put $x = 1$. Then

$$e = 1 + 1 + \frac{1}{2} + \frac{1}{2 \cdot 3} + \frac{1}{2 \cdot 3 \cdot 4} + \dots$$

Therefore, e is the base of the Napierian logarithms.

47. To integrate $\sin x dx$. $\int_{b_1}^{b_2} \sin x dx =$ limit of
 $\{\sin(b_1 + \delta x) + \sin(b_1 + 2\delta x) + \dots + \sin(b_1 + \overline{n+1} \cdot \delta x)\} \delta x$,
 where $b_2 = b_1 + (n+1)\delta x$.

By a known trigonometrical formula,

$$\cos(A - B) - \cos(A + B) = 2 \sin A \sin B.$$

Therefore, putting $B = \frac{1}{2} \delta x$

$$2 \sin(b_1 + \delta x) \sin \frac{1}{2} \delta x = \cos(b_1 + \frac{1}{2} \delta x) - \cos(b_1 + \frac{3}{2} \delta x)$$

$$2 \sin(b_1 + 2\delta x) \sin \frac{1}{2} \delta x = (\cos b_1 + \frac{3}{2} \delta x) - (\cos b_1 + \frac{5}{2} \delta x)$$

.

Adding these equations,

$$2 \sin \frac{1}{2} \delta x \{ \sin(b_1 + \delta x) + \sin(b_1 + 2\delta x) + \dots \\ + \sin(b_1 + \overline{n+1} \delta x) \}$$

$$= \cos(b_1 + \frac{1}{2} \delta x) - \cos(b_1 + \overline{n+1} \frac{3}{2} \delta x)$$

$$= \cos(b_1 + \frac{1}{2} \delta x) - \cos(b_2 + \frac{1}{2} \delta x);$$

$\therefore \int_{b_1}^{b_2} \sin x dx =$ limit of

$$\frac{\cos(b_1 + \frac{1}{2} \delta x) - \cos(b_2 + \frac{1}{2} \delta x)}{\sin \frac{1}{2} \delta x} \frac{1}{2} \delta x.$$

Assuming the demonstration given in the subsequent section on Rectification of Curves, that the limit of $\frac{1}{2} \delta x \div \sin \frac{1}{2} \delta x = 1$ when δx has the limit 0, we have,

$$\int_{b_1}^{b_2} \sin x dx = \cos b_1 - \cos b_2. \quad \text{Also, } \int \sin x dx = -\cos x.$$

48. To integrate $\cos x dx$. $\int_{b_1}^{b_2} \cos x dx =$ limit of
 $\{\cos (b_1 + \delta x) + \cos (b_1 + 2\delta x) + \dots + \cos (b_1 + \overline{n+1} \delta x)\} \delta x$,
 where $b_2 = b_1 + (n+1) \delta x$.

By the trigonometrical formula

$$\sin (A + B) - \sin (A - B) = 2 \cos A \sin B;$$

we have, putting $B = \frac{1}{2} \delta x$,

$$2 \cos (b_1 + \delta x) \sin \frac{1}{2} \delta x = \sin (b_1 + \frac{3}{2} \delta x) - \sin (b_1 + \frac{1}{2} \delta x)$$

$$2 \cos (b_1 + 2\delta x) \sin \frac{1}{2} \delta x = \sin (b_1 + \frac{5}{2} \delta x) - \sin (b_1 + \frac{3}{2} \delta x)$$

.....

$$\therefore 2 \sin \frac{1}{2} \delta x \{\cos (b_1 + \delta x) + \cos (b_1 + 2\delta x) + \dots + \cos (b_1 + \overline{n+1} \delta x)\}$$

$$= -\sin (b_1 + \frac{1}{2} \delta x) + \sin (b_2 + \frac{1}{2} \delta x),$$

$$\therefore \int_{b_1}^{b_2} \cos x dx = \text{limit of}$$

$$\frac{\sin (b_2 + \frac{1}{2} \delta x) - \sin (b_1 + \frac{1}{2} \delta x)}{\sin \frac{1}{2} \delta x} \cdot \frac{1}{2} \delta x = \sin b_2 - \sin b_1,$$

putting limit of $\frac{1}{2} \delta x \div \sin \frac{1}{2} \delta x = 1$, as in the last article.
 Also, $\int \cos x dx = \sin x$.

This integral may be obtained immediately from the preceding article, for

$$\int \cos x dx = -\int \sin \left(\frac{\pi}{2} - x \right) d \left(\frac{\pi}{2} - x \right) =$$

$$\text{(by the last article) } \cos \left(\frac{\pi}{2} - x \right) = \sin x.$$

49. To integrate $\frac{\sin x dx}{\cos^2 x}$ and $\frac{\cos x dx}{\sin^2 x}$. Since

$$\int \sin x dx = -\cos x, \quad \therefore d \cos x = -\sin x dx,$$

$$\therefore \int \frac{\sin x dx}{\cos^2 x} = -\int \frac{d \cos x}{\cos^2 x} = \frac{1}{\cos x} \text{ by Art. 44,}$$

50. Similarly, $\int \frac{\cos x dx}{\sin^2 x} = -\frac{1}{\sin x}$.

51. To integrate $(1 + \tan^2 x) dx$.

$$\tan^2 x dx = \frac{\sin^2 x dx}{\cos^2 x} = -\frac{\sin x d \cos x}{\cos^2 x} = -y du,$$

$$\text{if } y = \sin x \text{ and } du = \frac{d \cos x}{\cos^2 x}$$

$$\therefore \text{ by the last article } u = -\frac{1}{\cos x}, \text{ also } dy = \cos x dx.$$

Now, by Art. 40, $\int y du = yu - \int u dy$,

$$\therefore \int \tan^2 x dx = \frac{\sin x}{\cos x} - \int \frac{\cos x dx}{\cos x} = \tan x - x.$$

Therefore, $\int (1 + \tan^2 x) dx = x + \int \tan^2 x dx = \tan x$.

52. Similarly, $\int (1 + \cotan^2 x) dx$ will be found to be $-\cotan x$,

$$\text{or } \int (1 + \cotan^2 x) dx =$$

$$-\int \left\{ 1 + \tan^2 \left(\frac{\pi}{2} - x \right) \right\} d \left(\frac{\pi}{2} - x \right) = -\tan \left(\frac{\pi}{2} - x \right)$$

(as has been just proved) $= -\cotan x$.

53. To integrate $\frac{dx}{x^2 - a^2}$. If a be not zero,

$$\frac{1}{x^2 - a^2} = \frac{1}{2a} \left(\frac{1}{x - a} - \frac{1}{x + a} \right),$$

$$\therefore \int \frac{dx}{x^2 - a^2} = \frac{1}{2a} \int \frac{dx}{x - a} - \frac{1}{2a} \int \frac{dx}{x + a}$$

Now, $dx = d(x - a)$,

$$\therefore \int \frac{dx}{x - a} = \int \frac{d(x - a)}{x - a} = \log_1(x - a) \text{ (Art. 43),}$$

$$\begin{aligned} \therefore \int \frac{dx}{x^2 - a^2} &= \frac{1}{2a} \{ \log_1(x - a) - \log_1(x + a) \} \\ &= \frac{1}{2a} \log_1 \frac{x - a}{x + a}. \end{aligned}$$

If x be less than a , the logarithm just found is the logarithm of a negative quantity; and is, therefore, impossible. In order to express the integral in a possible form in this case, put

$$\begin{aligned} \int \frac{dx}{x^2 - a^2} &= - \int \frac{dx}{a^2 - x^2} = - \frac{1}{2a} \left\{ \int \frac{dx}{a - x} + \int \frac{dx}{a + x} \right\} \\ &= - \frac{1}{2a} \{ - \log(a - x) + \log(a + x) \} = \frac{1}{2a} \log \frac{a - x}{a + x}. \end{aligned}$$

54. To integrate $\frac{dx}{(x^2 \pm a^2)^{\frac{1}{2}}}$.

$$\text{Let } dy = dx + \frac{x dx}{(x^2 \pm a^2)^{\frac{1}{2}}}, \dots\dots\dots (1)$$

$$\text{Now } \int \frac{x dx}{(x^2 \pm a^2)^{\frac{1}{2}}} = \frac{1}{2} \int (x^2 \pm a^2)^{-\frac{1}{2}} d(x^2 \pm a^2)$$

$$= (x^2 \pm a^2)^{\frac{1}{2}} \text{ (Art. 44). } \therefore y = x + (x^2 \pm a^2)^{\frac{1}{2}}.$$

Also from (1),

$$dy = \frac{dx}{(x^2 \pm a^2)^{\frac{1}{2}}} \{(x^2 \pm a^2)^{\frac{1}{2}} + x\}, \therefore \frac{dy}{y} = \frac{dx}{(x^2 \pm a^2)^{\frac{1}{2}}}.$$

$$\text{Hence, } \int \frac{dx}{(x^2 \pm a^2)^{\frac{1}{2}}} = \log_e y = \log_e \{x + (x^2 \pm a^2)^{\frac{1}{2}}\}.$$

55. To integrate $\frac{dx}{x(a^2 \pm x^2)^{\frac{1}{2}}}$: where, in order that the denominator may be possible, a^2 is greater than x^2 , if x^2 be affected by the negative sign. In Art. 54, write $\frac{1}{a}$ for a , $\frac{1}{x}$ for x , and, therefore, $-\frac{1}{x^2} dx$ for dx .

$$\begin{aligned} \text{Then } \int \frac{-x^{-2} dx}{(x^{-2} \pm a^{-2})^{\frac{1}{2}}} &= -a \int \frac{dx}{x(a^2 \pm x^2)^{\frac{1}{2}}} \\ &= \log_e \{x^{-1} + (x^{-2} \pm a^{-2})^{\frac{1}{2}}\} = \log_e \frac{a + (a^2 \pm x^2)^{\frac{1}{2}}}{ax}, \\ \therefore \int \frac{dx}{x(x^2 \pm a^2)^{\frac{1}{2}}} &= \frac{1}{a} \log \frac{ax}{a + (a^2 \pm x^2)^{\frac{1}{2}}}. \end{aligned}$$

(since the logarithm of any quantity = - the logarithm of its reciprocal),

$$= \frac{1}{a} \log \frac{x}{a + (a^2 \pm x^2)^{\frac{1}{2}}} + \frac{1}{a} \log_e a,$$

of which expression the last term $\frac{1}{a} \log_e a$ may be omitted, as it disappears when the integral is taken between limits.

56. To integrate $\frac{dx}{(a^2 - x^2)^{\frac{1}{2}}}$: where $a > x$.

Let $dx = \cos y dy$. Then (Art. 48),

$$x = \sin y, (1 - x^2)^{\frac{1}{2}} = \cos y,$$

$$\therefore \int \frac{dx}{(1-x^2)^{\frac{1}{2}}} = \int \frac{\cos y dy}{\cos y} = y = \sin^{-1} x. \quad \text{Hence,}$$

$$\int \frac{dx}{(a^2-x^2)^{\frac{1}{2}}} = \int \frac{dx}{a \left(1-\frac{x^2}{a^2}\right)^{\frac{1}{2}}} = \int \frac{d\frac{x}{a}}{\left(1-\frac{x^2}{a^2}\right)^{\frac{1}{2}}} =$$

$\sin^{-1} \frac{x}{a} = \frac{\pi}{2} - \cos^{-1} \frac{x}{a} = -\cos^{-1} \frac{x}{a}$ if $\frac{\pi}{2}$ be included in the value of the integral at its inferior limit.

57. To integrate $\frac{dx}{x(x^2-a^2)^{\frac{1}{2}}}$. Let $\frac{a}{x^2} dx = \sin y dy$. The integral of the first side of this equation is $-\frac{a}{x}$, and of the second $-\cos y$; \therefore we may therefore put $\frac{a}{x} = \cos y$. Hence $\frac{(x^2-a^2)^{\frac{1}{2}}}{x} = \sin y$, and $\int \frac{dx}{x(x^2-a^2)^{\frac{1}{2}}} = \int \frac{x^2 dy \sin y}{a x^2 \sin y} = \frac{1}{a} \int dy = \frac{y}{a} = \frac{1}{a} \cos^{-1} \frac{a}{x} = \frac{1}{a} \sec^{-1} \frac{x}{a}$.

58. To integrate $\frac{dx}{(2ax-x^2)^{\frac{1}{2}}}$

$$\begin{aligned} \int \frac{dx}{(2ax-x^2)^{\frac{1}{2}}} &= -\int \frac{d(a-x)}{\{a^2-(a-x)^2\}^{\frac{1}{2}}} \\ &= \cos^{-1} \frac{a-x}{a} \text{ (Art. 56)} = \text{versin}^{-1} \frac{x}{a}. \end{aligned}$$

59. To integrate $\frac{dx}{a^2+x^2}$. Let $\frac{x}{a} = \tan y$,

$$dx = a(1 + \tan^2 y) dy \text{ (Art. 51),}$$

$$\begin{aligned} \therefore \int \frac{dx}{a^2+x^2} &= \int \frac{a(1+\tan^2 y) dy}{a^2(1+\tan^2 y)} = \frac{1}{a} \int dy \\ &= \frac{1}{a} \tan^{-1} \frac{x}{a}. \end{aligned}$$

Collecting the results of this Chapter, we have the following

TABLE OF FUNDAMENTAL INTEGRALS.

	ARTICLE
$\int a^x dx = \frac{a^x}{\log_e a}$	42
$\int x^n dx = \frac{x^{n+1}}{n+1}$ except $n = -1$ when,	44
$\int \frac{dx}{x} = \log_e x$	43
$\int \sin x \cdot dx = -\cos x$	47
$\int \cos x \cdot dx = \sin x$	48
$\int \frac{\sin x}{\cos^2 x} dx = \frac{1}{\cos x}$	49
$\int \frac{\cos x}{\sin^2 x} dx = -\frac{1}{\sin x}$	50
$\int (1 + \tan^2 x) dx = \tan x$	51
$\int (1 + \cotan^2 x) dx = -\cotan x$	52
$\int \frac{dx}{x^2 - a^2} = \frac{1}{2a} \log_e \frac{x-a}{x+a} \quad (x > a)$ $= \frac{1}{2a} \log_e \frac{a-x}{a+x} \quad (x < a)$	53
$\int \frac{dx}{(x^2 \pm a^2)^{\frac{1}{2}}} = \log_e \{x + (x^2 \pm a^2)^{\frac{1}{2}}\}$	54
$\int \frac{dx}{x(a^2 \pm x^2)^{\frac{1}{2}}} = \frac{1}{a} \log_e \frac{x}{a + (a^2 \pm x^2)^{\frac{1}{2}}}$	55
$\int \frac{dx}{\sqrt{a^2 - x^2}} = \sin^{-1} \frac{x}{a}, \text{ or } -\cos^{-1} \frac{x}{a}$	56

$$\int \frac{dx}{x(x^2 - a^2)^{\frac{1}{2}}} = \frac{1}{a} \cos^{-1} \frac{a}{x} = \frac{1}{a} \sec^{-1} \frac{x}{a} \dots\dots\dots 57$$

$$\int \frac{dx}{(2ax - x^2)^{\frac{1}{2}}} = \text{versin}^{-1} \frac{x}{a} \dots\dots\dots * \dots\dots\dots 58$$

$$\int \frac{dx}{a^2 + x^2} = \frac{1}{a} \tan^{-1} \frac{x}{a} \dots\dots\dots 59$$

60. The foregoing integrals are all found in terms of logarithmic, exponential, and circular functions. Tables may be obtained which contain numerical values of these functions computed to any required degree of accuracy. Therefore the values of these integrals may be completely determined. Similarly, other integrals which can be reduced to any of the forms in the preceding list, may be completely determined.

61. The operations of integration consist chiefly in reducing integrals to these fundamental forms. In many cases, however, this reduction cannot be effected by known methods. Where it is impracticable, resort is had to methods of expressing integrals in terms of convergent algebraical series, or in terms of elliptic and other functions not contained in the preceding list, but which have been partially tabulated.

62. For the present, however, attention will be confined to those integrals which can be reduced to the forms investigated above. The methods of effecting this reduction may be classified as follows:

1. Integration by Algebraical Transformation.
2. Integration by Parts.
3. Integration by Formulæ of Reduction.
4. Integration by Rational Fractions.
5. Integration by Rationalization.

Of each of these five methods a brief account will be given in the following sections.

SECTION V.

...TEGRATION BY ALGEBRAICAL TRANSFORMATION.

63. This method, of which instances occurred in Arts. 54, 56, &c., consists in finding for the expressions to be integrated algebraical equivalents which are of the forms of one of the fundamental integrals, or are the sum of quantities having any of those forms. The requisite transformation is effected by substitutions and other processes, for which no general rule can be given. It is only by continual practice and experience of the effect of various transformations that facility in the successful application of this method of integration can be attained. One or two examples are appended, but for an adequate knowledge of the subject, the student must be referred to larger collections of examples of the Integral Calculus.

64. Every polynomial of the form $(a + bx + cx^2 + \dots)^n dx$, may be integrated in finite terms when n is a positive integer, and the number of constants a, b, c , &c., finite. For the polynomial may be raised to the power n ; the result is the sum of a finite number of terms involving only integral powers of x , and each term may be integrated separately.

$$65. \text{ For example } \int (a + bx)^2 dx = \int (a^2 + 2abx + b^2x^2) dx \\ = a^2x + 2ab \frac{x^2}{2} + b^2 \frac{x^3}{3}.$$

66. If the function to be integrated can be expressed as the product of two quantities, Fx , and dFx , or more generally $(Fx)^m$, and dFx , it may be always integrated. For if Fx be put $= y$, the expression takes the form $y^m dy$, of which the integral (Art. 44) is $\frac{y^{m+1}}{m+1}$.

$$67. \text{ For example, } \int (a + bx + cx^2) (b + 2cx) dx \text{ becomes,}$$

$$68. \text{ Again, } \int (\log_e x)^n \frac{dx}{x} = \int (\log_e x)^n d(\log_e x) \\ = \frac{(\log_e x)^{n+1}}{n+1}.$$

$$69. \int \frac{dx}{e^x + 1} = -\int \frac{d(e^{-x})}{e^{-x}(e^x + 1)} = -\int \frac{d(e^{-x})}{1 + e^{-x}} \\ = -\int \frac{d(1 + e^{-x})}{1 + e^{-x}} = -\log(1 + e^{-x}).$$

70. All the preceding formulæ for integrals of functions of x may be extended to like functions of $a + bx$, by putting $a + bx = X$, $\therefore b dx = dX$, and $dx = \frac{1}{b} dX$.

In this manner it will be found that

$$\int a^{a+bx} dx = \frac{a^{a+bx}}{b \log_e a}$$

$$\int \frac{dx}{a+bx} = \frac{1}{b} \log_e(a+bx)$$

$$\int (a+bx)^n dx = \frac{1}{b} \frac{(a+bx)^{n+1}}{n+1} \text{ except } n = -1$$

$$\int \sin(a+bx) dx = -\frac{1}{b} \cos(a+bx)$$

$$\int \cos(a+bx) dx = \frac{1}{b} \sin(a+bx)$$

$$\int \{1 + \tan^2(a+bx)\} dx = \frac{1}{b} \tan(a+bx)$$

$$\int \{1 + \cotan^2(a+bx)\} dx = -\frac{1}{b} \cotan(a+bx).$$

71. A similar extension of formulæ for functions of $a^2 \pm x^2$, to like functions of $a + bx + cx^2$, where a , b , and

c are positive or negative, may be effected by the following transformation:

$$a + bx + cx^2 = c \left\{ \frac{a}{c} - \frac{b^2}{4c^2} + \left(\frac{b}{2c} + x \right)^2 \right\} = c (\Lambda + y^2),$$

if $\frac{a}{c} - \frac{b^2}{4c^2} = \Lambda$, where Λ may be positive or negative, and

$$\frac{b}{2c} + x = y, \quad \therefore dx = dy.$$

Hence it will be found that

$$\begin{aligned} \int \frac{dx}{a + bx + cx^2} &= \frac{1}{c} \int \frac{dy}{y^2 + \Lambda} \\ &= \frac{1}{c} \frac{1}{2(-\Lambda)^{\frac{1}{2}}} \log_e \frac{y - (-\Lambda)^{\frac{1}{2}}}{y + (-\Lambda)^{\frac{1}{2}}} \quad \text{Art. 53,} \\ &\quad (\Lambda \text{ negative}) \\ &= \frac{1}{c} \frac{1}{\Lambda^{\frac{1}{2}}} \tan^{-1} \frac{y}{\Lambda^{\frac{1}{2}}} \quad (\Lambda \text{ positive}), \text{ Art. 59.} \end{aligned}$$

$$\begin{aligned} \int \frac{dx}{(a + bx + cx^2)^{\frac{1}{2}}} &= \frac{1}{c^{\frac{1}{2}}} \int \frac{dy}{(\Lambda + y^2)^{\frac{1}{2}}} \\ &= \frac{1}{c^{\frac{1}{2}}} \log_e \{y + (y^2 + \Lambda)^{\frac{1}{2}}\} \quad (c \text{ positive,} \\ &\quad \Lambda \text{ positive or negative), Art. 54.} \\ &= \frac{1}{(-c)^{\frac{1}{2}}} \sin^{-1} \frac{y}{(-\Lambda)^{\frac{1}{2}}} \quad (\Lambda \text{ and } c \text{ negative),} \\ &\quad \text{Art. 56,} \\ &\quad (\text{impossible if } \Lambda \text{ be positive and } c \text{ negative).} \end{aligned}$$

SECTION VI.

INTEGRATION BY PARTS.

72. A FORMULA has been given, in Art. 40, of which very extensive use is made in integration, and of which applications have been already given in Art. 45 and 51. This formula, called the formula of integration by parts, is

$$\int u dv = uv - \int v du.$$

Any differential function of one independent variable may be put in the form $u dv$. If, then, $\int v du$ can be found, $\int u dv$ can also be determined by the preceding formula.

73. To integrate $x \log_e x dx$. Let $\log_e x = u$, whence $\frac{dx}{x} = du$ (Art. 43). Also let $x dx = dv$, whence $\frac{1}{2} x^2 = v$, (Art. 44),

$$\begin{aligned} \therefore \int x \log_e x dx &= \int u dv = uv - \int v du \\ &= \frac{1}{2} x^2 \log_e x - \int \frac{1}{2} x^2 \frac{dx}{x} \\ &= \frac{1}{2} x^2 \log_e x - \frac{1}{4} x^2. \end{aligned}$$

74. To integrate $x^r dx$. Let $x^r dx = dv$. Then $r^r = v$, Art. 41. Also, let $x = u$; $dx = du$.

$$\begin{aligned} \int x^r dx &= \int u dv = uv - \int v du = x^r - \int r^r dx \\ &= x^r - r^r. \end{aligned}$$

75. To integrate $\int \frac{x^2 dx}{(1-x^2)^2}$. Let $dv = \frac{2x dx}{(1-x^2)^2}$
 $= -\frac{d(1-x^2)}{(1-x^2)^2}$, \therefore (Art. 44) $v = \frac{1}{1-x^2}$. Also let $u = \frac{1}{2} x$.

The formula gives

$$\begin{aligned}\int \frac{x^2 dx}{(1-x^2)^2} &= \frac{1}{2} \frac{x}{1-x^2} - \frac{1}{2} \int \frac{dx}{1-x^2} \\ &= \frac{1}{2} \frac{x}{1-x^2} + \frac{1}{2} \int \frac{dx}{x^2-1} \\ &= \frac{1}{2} \frac{x}{1-x^2} + \frac{1}{4} \log_4 \frac{x-1}{x+1}.\end{aligned}$$

76. To integrate $dx (a^2 - x^2)^{\frac{1}{2}}$. Since

$$\int \frac{-x dx}{(a^2 - x^2)^{\frac{3}{2}}} = \int \frac{1}{2} \frac{d(a^2 - x^2)}{(a^2 - x^2)^{\frac{3}{2}}} = (a^2 - x^2)^{-\frac{1}{2}}, \text{ by Art. 44.}$$

$$\text{Therefore, } d(a^2 - x^2)^{\frac{1}{2}} = \frac{-x dx}{(a^2 - x^2)^{\frac{3}{2}}}.$$

Hence, integrating by parts,

$$\begin{aligned}\int dx (a^2 - x^2)^{\frac{1}{2}} &= x(a^2 - x^2)^{\frac{1}{2}} + \int \frac{x^2 dx}{(a^2 - x^2)^{\frac{3}{2}}} \\ &= x(a^2 - x^2)^{\frac{1}{2}} + \int \frac{a^2 dx}{(a^2 - x^2)^{\frac{3}{2}}} - \int \frac{(a^2 - x^2) dx}{(a^2 - x^2)^{\frac{3}{2}}} \\ &= x(a^2 - x^2)^{\frac{1}{2}} + a^2 \sin^{-1} \frac{x}{a} - \int \frac{dx}{(a^2 - x^2)^{\frac{1}{2}}};\end{aligned}$$

consequently, transferring to the first side of the equation the last member of the second side, we have

$$\int dx (a^2 - x^2)^{\frac{1}{2}} = \frac{1}{2} x(a^2 - x^2)^{\frac{1}{2}} + \frac{1}{2} a^2 \sin^{-1} \frac{x}{a}.$$

77. To integrate $x \cos x dx$. Putting $\int \cos x dx = \sin x$,

$$\begin{aligned}\text{we have } \int x \cos x dx &= x \sin x - \int \sin x dx \\ &= x \sin x + \cos x.\end{aligned}$$

78. *To integrate $e^x \cos x dx$.* Performing the operation of integration by parts twice,

$$\begin{aligned}\int e^x \cos x dx &= e^x \cos x + \int e^x \sin x dx \\ &= e^x \cos x + e^x \sin x - \int e^x \cos x dx.\end{aligned}$$

Transposing and dividing both sides of the resulting equation by 2,

$$\int e^x \cos x dx = \frac{1}{2} e^x (\cos x + \sin x).$$

SECTION VII.

FORMULÆ OF REDUCTION.

79. By Formulæ of Reduction, integrals involving powers of functions are expressed by integrals involving higher or lower powers of the same functions. These formulæ are obtained by the principles of integration by parts and algebraical transformation.

80. For instance, the integral of $x^m \cos x$ may be made to depend on a function of x^{m-1} ; the latter, similarly, on a function of x^{m-2} , and so on continually. If m be a positive integer, and the process be continued a sufficient number of times, the last integral is that of $\cos x$ or $\sin x$, which have been found in Art. 47 and 48.

Integrating by parts,

$$\begin{aligned} \int x^m \cos x &= x^m \sin x - m \int x^{m-1} \sin x dx \\ &= x^m \sin x + m x^{m-1} \cos x - m \cdot m-1 \int x^{m-2} \cos x dx \\ &= x^m \sin x + m x^{m-1} \cos x - m \cdot m-1 x^{m-2} \sin x - \\ &\quad m \cdot m-1 \cdot m-2 x^{m-3} \cos x + \&c. \end{aligned}$$

the positive and negative signs succeeding in pairs.

For instance, let $m = 4$

$$\begin{aligned} \int x^4 \cos x dx &= x^4 \sin x - 4 \int x^3 \sin x dx \\ &= x^4 \sin x + 4 \cdot x^3 \cos x - 3 \cdot 4 \int x^2 \cos x dx \\ &= x^4 \sin x + 4 \cdot x^3 \cos x - 3 \cdot 4 x^2 \sin x + 3 \cdot 4 \cdot 2 \int x \sin x dx \\ &= x^4 \sin x + 4 x^3 \cos x - 3 \cdot 4 \cdot x^2 \sin x - \\ &\quad 3 \cdot 4 \cdot 2 \cdot x \cos x + 3 \cdot 4 \cdot 2 \cdot 1 \sin x. \end{aligned}$$

81. The preceding integral is an instance of a general formula which is an extension of John Bernouilli's series. By the same method as that by which Bernouilli's series was obtained (Art. 45), we have, if P and Q be functions of x ,

and $Q', Q'', Q''' \dots$ successive differential coefficients of Q with respect to x , and

$$\begin{aligned} P_1 &= \int P dx, P_2 = \int P_1 dx, P_3 = \int P_2 dx, \&c. \\ \int PQ dx &= QP_1 - \int Q'P_1 dx \\ &= QP_1 - Q'P_2 + \int Q''P_2 dx = \&c. \\ &= QP_1 - Q'P_2 + Q''P_3 - Q'''P_4 + Q''''P_5 - \dots \mp \int Q^{(n)}P_n dx. \end{aligned}$$

82. To integrate $x^n \epsilon^r$, n being a positive integer. Here

$$\begin{aligned} Q &= x^n, Q' = nx^{n-1}, Q'' = n \cdot n - 1 \cdot x^{n-2}, \\ Q''' &= n \cdot n - 1 \cdot n - 2 \cdot x^{n-3} \&c., \end{aligned}$$

$$Q^{(n)} = n \cdot n - 1 \dots 2 \cdot 1, P = \epsilon^r, P_1 = \epsilon^r, P_2 = \epsilon^r, \&c.$$

Therefore,

$$\begin{aligned} \int x^n \epsilon^r dx &= x^n \epsilon^r - nx^{n-1} \epsilon^r + n \cdot n - 1 \cdot x^{n-2} \epsilon^r - \dots \\ &\quad \mp n \cdot n - 1 \dots 2 \cdot 1 \cdot \int \epsilon^r dx \\ &= \epsilon^r (x^n - nx^{n-1} + n \cdot n - 1 \cdot x^{n-2} - \dots \\ &\quad \mp n \cdot n - 1 \dots 2 \cdot 1). \end{aligned}$$

The formula of the last article but one is inapplicable, except where the successive integrals $P_1, P_2, P_3 \dots$ are simple quantities, and $Q^{(n)}$ such that $\int Q^{(n)} P_n dx$ may be found. This will not generally be the case for functions involving fractional indices. Such functions may, however, be frequently reduced by combining integration by parts with algebraical transformation, as in the following example:—

83. To integrate $(a^2 - x^2)^{\frac{n}{2}} dx$, n being an odd integer. In the formula for integration by parts

$$\int u dv = uv - \int v du, \text{ let } (a^2 - x^2)^{\frac{n}{2}} = u.$$

$$\text{Then } -nx(a^2 - x^2)^{\frac{n}{2}-1} dx = du; dv = dx.$$

$$\int (a^2 - x^2)^{\frac{n}{2}} dx = (a^2 - x^2)^{\frac{n}{2}} x + n \int (a^2 - x^2)^{\frac{n}{2}-1} x^2 dx \dots (1.)$$

Now,

$$(a^2 - x^2)^{\frac{n}{2}-1} x^2 = -(a^2 - x^2)(a^2 - x^2)^{\frac{n}{2}-1} + a^2(a^2 - x^2)^{\frac{n}{2}-1}$$

Integrating this equation, $n \int (a^2 - x^2)^{\frac{n}{2}} dx =$

$$na^2 \int (a^2 - x^2)^{\frac{n}{2}-1} dx - n \int (a^2 - x^2)^{\frac{n}{2}-1} x^2 dx \dots (2.)$$

Adding (1) and (2), and dividing both sides of the resulting equation by $n + 1$,

$$\int (a^2 - x^2)^{\frac{n}{2}} dx = \frac{x}{n+1} (a^2 - x^2)^{\frac{n}{2}} + \frac{na^2}{n+1} \int (a^2 - x^2)^{\frac{n}{2}-1} dx.$$

By this formula of reduction, the integral is made to depend ultimately on $\int (a^2 - x^2)^{-\frac{1}{2}} dx$, which has been found in Art. 56.

84. To integrate $\frac{dx}{(x^2 \pm a^2)^p}$. In the formula of integration

$$\int u dv = uv - \int v du, \text{ put } v = x, u = \frac{1}{(x^2 \pm a^2)^p},$$

$$\therefore du = -\frac{2px dx}{(x^2 \pm a^2)^{p+1}}. \text{ Then}$$

$$\begin{aligned} \int \frac{dx}{(x^2 \pm a^2)^p} &= \frac{x}{(x^2 \pm a^2)^p} + 2p \int \frac{x^2 dx}{(x^2 \pm a^2)^{p+1}} \\ &= \frac{x}{(x^2 \pm a^2)^p} + 2p \int \frac{dx}{(x^2 \pm a^2)^p} \mp 2pa^2 \int \frac{dx}{(x^2 \pm a^2)^{p+1}}. \end{aligned}$$

Whence, transposing, putting $p + 1 = n$,

$$\begin{aligned} &\int \frac{dx}{(x^2 \pm a^2)^n} \\ &= \frac{\pm 1}{2n-2} \frac{x}{a^2(x^2 \pm a^2)^{n-1}} \pm \frac{2n-3}{2n-2} \frac{1}{a^2} \int \frac{dx}{(x^2 \pm a^2)^{n-1}}. \end{aligned}$$

Except when $n = 1$.

When n is a positive integer, this formula of reduction reduces the integral ultimately to $\int \frac{dx}{x^2 + a^2} = \tan^{-1} \frac{x}{a}$ (when a^2 has the positive sign). When a^2 has the negative sign, the ultimate integral is $\int \frac{dx}{x^2 - a^2} = \frac{1}{2a} \log \frac{x-a}{x+a}$.

$$85. \text{ To integrate } \int \frac{(A + Bx) dx}{(x^2 + 2bx + c)^n} = \frac{B}{2} \int \frac{(2x + 2b) dx}{(x^2 + 2bx + c)^n} \\ + (A - Bb) \int \frac{dx}{(x^2 + 2bx + c)^n} =$$

(Art. 44, except when $n = 1$),

$$\frac{-B}{2(n-1)(x^2 + 2bx + c)^{n-1}} + \\ (A - Bb) \int \frac{dx}{\{(x+b)^2 + (c-b^2)\}^n} = \\ \frac{-B}{2(n-1)(x^2 + 2bx + c)^{n-1}} + \\ \frac{A - Bb}{2n-2} \frac{x+b}{(c-b^2)\{(x+b)^2 + (c-b^2)\}^{n-1}} + \\ \frac{2n-3}{2n-2} \frac{1}{c-b^2} (A - Bb) \int \frac{dx}{\{(x+b)^2 + c-b^2\}^{n-1}},$$

by the last article, putting $x+b$ for x , and $c-b^2$ for a^2 . All the constants may be positive or negative.

When $n = 1$, we have from the first equation of this article and Arts. 43 and 59,

$$* \int \frac{(A + Bx) dx}{x^2 + 2bx + c} = \frac{B}{2} \log_1 (x^2 + 2bx + c) \\ + \frac{A - Bb}{(c-b^2)^{\frac{1}{2}}} \tan^{-1} \frac{x+b}{(c-b^2)^{\frac{1}{2}}}.$$

SECTION VIII.

RATIONAL FRACTIONS.

86. A rational integral function of x is the sum of a finite number of terms which involve only positive integral powers of x , and these as factors.

87. A fraction rational with respect to x is a fraction of which the numerator and denominator are rational integral functions of x .

88. The partial fractions of a given rational fraction are those rational fractions with different denominators of which the sum is equal to the given fraction.

89. If the numerator of a rational fraction, cleared of negative indices of x , be of higher dimensions in x than the denominator (i.e. contain higher powers of x than the denominator), the fraction may be reduced to a rational integral function, + a rational integral fraction of lower dimensions in the numerator than in the denominator.

For if a rational function of x , $ax^{p+q} + bx^{p+q-1} + \dots$ be actually divided by another such function of lower dimensions in x , $Ax^p + Bx^{p-1} + Cx^{p-2} + \dots$ (p and q being positive integers), it will be found that the quotient consists of terms with descending positive integral powers of x , commencing with the index q , and ending with the index 0; and the remainder, after division, has terms with only positive integral powers of x , commencing with the index $p-1$, and ending with the index 0. So that

$$\frac{ax^{p+q} + bx^{p+q-1} + cx^{p+q-2} + \dots}{Ax^p + Bx^{p-1} + Cx^{p-2} + \dots} =$$

$$A_1x^q + B_1x^{q-1} + \dots + \frac{ax^{p-1} + bx^{p-2} + \dots}{Ax^p + Bx^{p-1} + \dots},$$

where the coefficients A, B, \dots, a, b, \dots are to be determined in the course of the process of division.

90. The rational function $A, x^n + B, x^{n-1} + \dots$ is immediately integrable by Art. 44. So that for the complete integration of a rational fraction, all that is required is to integrate a rational fraction of which the numerator is of lower dimensions than the denominator.

91. If in any rational integral function of x, x^2 be assumed to have the value $bx + c$, the function becomes linear (i. e. of one dimension in x). For $x^2 = x \cdot x = (bx + c)x$ by the hypothesis; $= bx^2 + cx$, which again, by the hypothesis, is equal to $b(bx + c) + cx$, which is linear.

So, likewise, may x^3, x^4 , &c., be reduced to a linear form. So that any rational function of x takes the linear form

$$\alpha x + \beta,$$

when $bx + c$ is substituted continually for x ; α and β being quantities not affected by $\sqrt{-1}$.

92. If the preceding $\alpha x + \beta = 0$ (1), then $\alpha = 0$ and $\beta = 0$. For the original assumption $x^2 = bx + c$, gives $x = \frac{1}{2} \{b + (b^2 + 4c)^{\frac{1}{2}}\}$, and $x = \frac{1}{2} \{b - (b^2 + 4c)^{\frac{1}{2}}\}$. Therefore equation (1) is required to be true for two different values of x (except when $4c = -b^2$); call them x_1, x_2 . Then

$$\begin{aligned} \alpha x_1 + \beta &= 0 \\ \alpha x_2 + \beta &= 0. \end{aligned}$$

Subtracting, $\alpha(x_1 - x_2) = 0$, $\therefore \alpha = 0$, since $x_1 - x_2$ is not zero.

Substituting $\alpha = 0$ in either of the equations last written, we get $\beta = 0$.

93. To show that real quantities, A and B , independent of x , may be found such that

$$\frac{\phi x}{(x^2 - bx - c)^n \psi x} = \frac{Ax + B}{(x^2 - bx - c)^n} + \chi x \dots\dots (1.)$$

where ϕx and ψx are rational integral functions, and do not contain $x^2 - bx - c$ as a factor, χx a rational fraction, and n a positive integer.

$$\frac{\phi x - (Ax + B) \psi x}{(x^2 - bx - c)^n \psi x} = \chi x \dots\dots\dots (2.)$$

Now, by a principle proved in the theory of equations, any

rational integral function of x contains $x^2 - bx - c$ as a factor if the function = 0 when $x^2 - bx - c = 0$.

The numerator on the first side of (2) is a rational integral function of x . If, therefore, real quantities A and B can be determined, so that this numerator = 0 when $x^2 - bx - c = 0$; then the numerator is divisible once, at least, by $x^2 - bx - c$.

The quotient will be a real rational integral function ϕ, x . Then (2) becomes

$$\frac{\phi, x}{(x^2 - bx - c)^{n-1} \psi x} = \chi x \dots\dots\dots (3.)$$

or χx is a rational fraction.

It only remains to be shown that A and B are real quantities, when determined by the condition supposed, namely, that

$$\phi x - (Ax + B) \psi x = 0 \dots (4), \text{ when } x^2 - bx - c = 0.$$

It has been shown by the last article but one, that when $x^2 - bx - c = 0$, or $x^2 = bx + c$, ϕx is reduced to the linear form $\alpha x + \beta$, and ψx to a similar linear form $\alpha' x + \beta'$, where $\alpha, \beta, \alpha', \beta'$, are real quantities; therefore, (4) takes the form

$$\alpha x + \beta - (Ax + B)(\alpha' x + \beta') = 0,$$

or, multiplying the quantities in parentheses, and putting $x^2 = bx + c$,

$$\alpha x + \beta - A\alpha'(bx + c) + A\beta'x + B(\alpha'x + \beta') = 0.$$

By the last article the coefficient of x in this equation is zero, and the quantity independent of x is zero, or

$$\alpha - A(\alpha'b - \beta') + B\alpha' = 0,$$

$$\beta - A\alpha'c + B\beta' = 0.$$

(Except, as before, when $-4c = b^2$, when $(x^2 - bx - c)^n = (x - \frac{1}{2}b)^{2n}$; see next article but one.)

It is clear that the values of A and B found from these equations are real quantities, independent of x .

From (1) and (3),

$$\begin{aligned} & \frac{\phi x}{(x^2 - bx - c)^n \psi x} = \frac{Ax + B}{(x^2 - bx - c)^n} \\ & + \frac{\phi, x}{(x^2 - bx - c)^{n-1} \psi x} \dots\dots\dots (\alpha.) \end{aligned}$$

94. Supposing the last fraction in this equation in its lowest terms in $x^2 - bx - c$, we have, similarly,

$$\frac{\phi_1 x}{(x^2 - bx - c)^{n-1} \psi x} = \frac{A_1 x + B_1}{(x^2 - bx - c)^{n-1}}$$

$$+ \frac{\phi_2 x}{(x^2 - bx - c)^{n-2} \psi x},$$

and so on. Therefore, generally,

$$\frac{\phi x}{(x^2 - bx - c)^n \psi x} = \frac{Ax + B}{(x^2 - bx - c)^n}$$

$$+ \frac{A_1 x + B_1}{(x^2 - bx - c)^{n-1}} + \dots + \frac{A_n x + B_n}{x^2 - bx - c} + \frac{\phi x}{\psi x},$$

where ϕx is a rational integral function of x .

95. To shew that a real quantity, C , independent of x may be found such that

$$\frac{\phi x}{(x - a)^n \psi x} = \frac{C}{(x - a)^n} + \chi x \dots \dots \dots (1.)$$

where ϕx and ψx are rational integral functions of x , χx a rational fraction, n a positive integer, ϕa not zero, and ψa not zero.

$$\frac{\phi x - C \psi x}{(x - a)^n \psi x} = \chi x \dots \dots \dots (2.)$$

Let $C = \frac{\phi a}{\psi a}$ (which is finite by hypothesis).

Then $\phi x - \frac{\phi a}{\psi a} \psi x$, the numerator of the fraction on the first side of (2), is zero when $x - a$ is zero; and, therefore, is divisible by $x - a$, once at least.

Then (2) becomes

$$\frac{\phi_1 x}{(x - a)^{n-1} \psi x} = \chi x.$$

From this equation and (1),

$$\frac{\phi x}{(x - a)^n \psi x} = \frac{C}{(x - a)^n} + \frac{\phi_1 x}{(x - a)^{n-1} \psi x} \dots \dots \dots (\beta.)$$

96. If the last fraction in (β) be in its lowest terms with respect to $x - a$, the numerator does not contain $x - a$, and $\phi_1 a$ is not zero. We, therefore, proceed as before, and put

$$\frac{\phi_1 x}{(x - a)^{n-1} \psi x} = \frac{C_1}{(x - a)^{n-1}} + \frac{\phi_2 x}{(x - a)^{n-2} \psi x},$$

and so on. Therefore, ultimately,

$$\frac{\phi x}{(x - a)^n \psi x} = \frac{C}{(x - a)^n} + \frac{C_1}{(x - a)^{n-1}} + \dots + \frac{\phi x}{\psi x}.$$

97. In the formulæ marked (α) and (β) in the last article and the preceding, respectively, the numerators ϕx , $\phi_1 x$, $\phi_2 x$, &c., have been supposed *not* to contain the simple or quadratic factor expressed in the denominators. If, however, either of these numerators happen to contain any number of times a factor of its denominator, reduce the rational fraction by division by the factor that number of times, and proceed to reduce the resulting fraction into its partial fractions.

98. If the quantities $U_1, U_2 \dots$ represent quadratic, and $V_1, V_2 \dots$ simple factors, we have, by the last two articles, continually reducing the rational fractions into partial fractions,

$$\begin{aligned} & \frac{\phi x}{U_1^{n_1} U_2^{n_2} \dots V_1^{m_1} V_2^{m_2}} \\ &= \frac{Ax + B}{U_1^{n_1}} + \frac{A_1 x + B_1}{U_1^{n_1 - 1}} + \dots + \frac{Ax_{n_1} + B_{n_1}}{U_1} \\ &+ \frac{A'x + B'}{U_2^{n_2}} + \frac{A'_1 x + B'_1}{U_2^{n_2 - 1}} - \dots + \frac{A'_{n_2} x + B'_{n_2}}{U_2} \\ &+ \&c. \\ &+ \frac{C}{V_1^{m_1}} + \frac{C_1}{V_1^{m_1 - 1}} + \dots + \frac{C_{m_1}}{V_1} \\ &+ \frac{C'}{V_2^{m_2}} + \frac{C'_1}{V_2^{m_2 - 1}} + \dots + \frac{C'_{m_2}}{V_2} \\ &+ \&c. \end{aligned}$$

99. In resolving rational fractions into partial fractions, the greatest difficulty occurs in those cases in which there are quadratic denominators of the partial fractions, and their numerators are therefore linear in x . Where, however, the partial fractions have only simple denominators, there are no (A)s and (B)s, and the numerators (C) are easily found by either of the following methods.

(1.) Clear the equation of the last article of fractions, by multiplying by the denominator of the first side. As the denominator is supposed to contain no quadratic factors, it is equal to $V_1^{m_1} \cdot V_2^{m_2} \dots$, and therefore is of $m_1 + m_2 + \dots$ dimensions in x . Therefore, when the equation is cleared of fractions by multiplication by this denominator, there are terms in the second side of the resulting equation of $(m_1 + m_2 + \dots) - 1$ dimensions in x . The new equation contains, therefore, $(m_1 + m_2 + \dots)$ different powers of x , and (equating coefficients of those powers) there are therefore $m_1 + m_2 + \dots$ equations to find the $m_1 + m_2 + \dots$ quantities (c).

EXAMPLE.—To resolve $\frac{1}{x^2 - x^2 - x + 1} = \frac{1}{(x-1)^2(x+1)}$ into partial fractions. Assume

$$\frac{1}{(x-1)^2(x+1)} = \frac{C}{x-1} + \frac{C_1}{(x-1)^2} + \frac{C_2}{x+1}.$$

Clearing the equation of fractions

$$1 = C(x^2 - 1) + C_1(x + 1) + C_2(x^2 - 2x + 1) \dots (a.)$$

Equating coefficients of x^2 , $0 = C + C_2$

.. .. of x , $0 = C_1 - 2C_2$

.. .. of x^0 , $1 = -C + C_1 + C_2$.

Adding these equations, we have $1 = 2C_1$, $\therefore C_1 = \frac{1}{2}$. Substituting this in the second of these equations, we have $C_2 = \frac{1}{4}$, and therefore, from the first equation, $C = -\frac{1}{4}$.

$$\therefore \int \frac{dx}{x^2 - x^2 - x + 1} = -\frac{1}{4} \int \frac{dx}{x-1} + \frac{1}{2} \int \frac{dx}{(x-1)^2} + \frac{1}{4} \int \frac{dx}{x+1} = -\frac{1}{4} \log(x-1) - \frac{1}{2} \frac{1}{x-1} + \frac{1}{4} \log(x+1).$$

(2.) The numerators of the simple partial fractions may be found by another method, which is frequently more convenient than that of equating coefficients. In the equation cleared of fractions, give x successively the values which make each of the (V)s zero. Then, in each case, all the (C)s disappear but one, which is therefore determined.

For instance, in the equation (a), in the last example, put $x = 1$. Then (a) becomes $1 = C_1 \cdot 2$ or $\frac{1}{2} = C_1$.

Put $x = -1$. Then (a) becomes

$$1 = C_2 \cdot 4, \text{ or } C_2 = \frac{1}{4}.$$

100. By this method of substitution, it is clear that as many coefficients (C) are determined as different simple factors of the denominator of the fraction to be resolved into partial fractions are made zero. But when this denominator contains higher powers than the first of any of its factors, there are more (C)s to be determined than there are *different* factors. For instance, in the example just considered only two different factors $x - 1$ and $x + 1$ can be made zero, and therefore only two out of the three (C)s can be thus found.

To determine the remaining (C)s, differentiate each side of the equation equivalent to (a) in the last example; for since that equation holds for all values of x , the differential coefficients of the two sides of the equation are equal.

In the new equation obtained by differentiation, put the factors = 0 successively, and so obtain more values of (C)s. Then, if necessary, differentiate again, and equate factors to zero, and so on continually, till all the (C)s are found.

For instance, in the last example, differentiate (a), then

$$0 = C \cdot 2x + C_1 + C_2 \cdot 2 \cdot (x - 1).$$

Put $x = 1$. Then

$$0 = C \cdot 2 + C_1, \quad \therefore \text{since } C_1 = \frac{1}{2}, C = -\frac{1}{4}.$$

101. We will take, as another instance, a fraction to be resolved of which the denominator contains the third power of a factor, and which therefore requires two successive differentiations.

$$\frac{2x^2 + 1}{(x - 2)^3(x + 3)^2} = \frac{C}{x - 2} + \frac{C_1}{(x - 2)^2} + \frac{C_2}{(x - 2)^3} + \frac{c}{x + 3} + \frac{c_1}{(x + 3)^2}.$$

Clearing this equation of fractions,

$$2x^2 + 1 = C(x-2)^2(x+3)^2 + C_1(x-2)(x+3)^2 + C_2(x+3)^2 + c(x-2)^2(x+3) + c_1(x-2)^2 \dots \dots (a.)$$

Putting $x = 2$, $9 = C_2 \cdot 25$, $\therefore C_2 = \frac{9}{25}$

$$x = -3, 19 = c_1(-5)^2, \therefore c_1 = -\frac{19}{5^2}.$$

Now differentiate (a).

$$4x = C\{2(x-2)(x+3)^2 + 2(x-2)^2(x+3)\} + C_1\{(x+3)^2 + 2(x-2)(x+3)\} + C_2 2(x+3) + c\{3(x-2)^2(x+3) + (x-2)^2\} + c_1 3(x-2)^2 \dots (b.)$$

Putting $x = 2$, $8 = C_1 \cdot 25 + C_2 \cdot 10$, $\therefore C_1 = \frac{22}{5}$, since $C_2 = \frac{9}{25}$

$$x = -3, -12 = c(-5)^2 + c_1 3(5)^2 = c(-5)^2 - \frac{57}{5}$$

$$\text{since } c_1 = -\frac{19}{5^2}, \therefore c = -\frac{1}{5^2} \left(\frac{57}{5} - 12 \right) = \frac{3}{5^4}.$$

Differentiate (b), retaining only terms which do not vanish when $x = 2$; then

$$4 = C \cdot 2 \cdot (x+3)^2 + C_1 \{2(x+3) + 2(x+3)\} + C_2 \cdot 2, \\ x \text{ being supposed} = 2. \text{ Consequently,}$$

$$4 = C \cdot 2 \cdot 5^2 + C_1 \cdot 2 \cdot (5+5) + 2C_2, \therefore C = -\frac{3}{5^4}$$

$$\frac{2x^2 + 1}{(x-2)^2(x+3)^2} = -\frac{3}{5^4(x-2)^2} + \frac{22}{5^2(x-2)^2} + \frac{9}{25(x-2)^2} \\ + \frac{3}{5^4(x+3)} - \frac{19}{5^2(x+3)^2}$$

as may be verified.

102. Where the denominator of the fraction to be resolved contains quadratic factors (and especially where each such

factor is trinomial ($= x^2 - bx - c$), the difficulty of resolving the proposed fraction is considerably increased. The student will probably be inclined to think that considerable labour is saved by the following method, if he will compare the amount of work which it requires for a difficult example with the amount required for the same example by other methods which have been proposed.

Assume the proposed fraction to equal a series of partial fractions, as in Art. 96. Clear this equation of fractions, and so obtain an equation corresponding to (a) in the last examples. In this equation make each quadratic factor $x^2 - bx - c = 0$ (i.e., substitute $bx + c$ for x^2). Then the equation may be reduced to the linear form $ax + \beta = 0$ (Art. 91), and $a = 0, \beta = 0$ (Art. 92). From these two equations the A and B corresponding to the factor $x^2 - bx - c$ may be found.

This method will give as many different (A)s and (B)s as there are *different* quadratic factors, successively made zero.

If there be more (A)s and (B)s (i.e., if any quadratic factor appear in (a) of higher power than the first), differentiate (a), and in this derived equation make all the quadratic factors zero successively, then, if necessary, differentiate again, and in the second derived equation make the factors again zero, and so on continually, till all the (A)s and (B)s are found. The (C)s, if any, corresponding to simple factors, may be determined from (a), and the derived equations by the method already explained.

Let us take, first, an instance of the simplest case, that of quadratic factor, which wants its second term, and is therefore binomial.

$$103. \text{ To integrate } \frac{x^3 dx}{(x-1)^2 (x^2+1)},$$

$$\text{Assume } \frac{x^3}{(x-1)^2 (x^2+1)} = \frac{Ax+B}{x^2+1} + \frac{C}{x-1} + \frac{C_1}{(x-1)^2},$$

$$\therefore x^3 = (Ax+B)(x-1)^2 + C(x^2+1)(x-1) - C_1(x^2+1) \dots (a.)$$

First, to determine the (C)s by the method of Art. 98, let $x = 1, \therefore 1 = C_1 \cdot 2$, or $C_1 = \frac{1}{2}$.

Differentiating (a), and for brevity retaining only terms which do not vanish when $x = 1$, we have then

$$3x^2 = C(x^2 + 1) + C_1 2x,$$

where $x = 1$. Consequently $3 = C \cdot 2 + C_1 \cdot 2$, or $C = \frac{3}{2} - C_1 = 1$.

Secondly, to find A and B by the method of the last article. Make the quadratic factor zero in (a); i. e. put -1 for x^2 continually; (a) becomes (expanding $(x - 1)^2$ and putting $x^2 = x \cdot x = -x$)

$$\begin{aligned} -x &= (Ax + B)(-1 - 2x + 1) \\ &= 2A - 2Bx \text{ (putting } -2Ax^2 = 2A), \\ \therefore 0 &= 2A - (2B - 1)x, \end{aligned}$$

which is of the linear form required by Art. 91. By Art. 92 the coefficient of x in this equation, and the quantity independent of x are each zero; $\therefore A = 0$; $2B - 1 = 0$, or

$$B = \frac{1}{2}. \text{ Hence, } \frac{x^2}{(x-1)^2(x^2+1)}$$

$$= \frac{1}{2} \frac{1}{x^2+1} + \frac{1}{x-1} + \frac{1}{2} \frac{1}{(x-1)^2},$$

$$\therefore \int \frac{x^2 dx}{(x-1)^2(x^2+1)} = \frac{1}{2} \tan^{-1} x + \log(x-1) - \frac{1}{2} \frac{1}{x-1}.$$

Next take a case in which all the operations for resolving partial fractions are required, and the quadratic factor is trinomial, and raised to a higher power than the first.

104. To integrate $\frac{x^2 + 3x - 2}{(x^2 - x + 1)^2 (x - 1)^2}$. Assume the

$$\text{fraction} = \frac{Ax + B}{x^2 - x + 1} + \frac{A_1 x + B_1}{(x^2 - x + 1)^2} + \frac{C}{x - 1} + \frac{C_1}{(x - 1)^2}$$

$$\begin{aligned} x^2 + 3x - 2 &= (Ax + B)(x^2 - x + 1)(x - 1)^2 \\ &+ (A_1 x + B_1)(x - 1)^2 + C(x^2 - x + 1)^2(x - 1) \\ &+ C_1(x^2 - x + 1)^2 \dots (a). \end{aligned}$$

First, to determine the (C)s, Art. 100. Put $x=1$, $\therefore 2=C_1$. Differentiate, retaining only terms which do not vanish when $x=1$,

$$2x + 3 = C(x^2 - x + 1)^2 + C_1 2 \cdot (2x - 1)(x^2 - x + 1),$$

$$\text{where } x=1, \therefore 5 = C + 2C_1, \therefore C=1.$$

Secondly, to find the (A)s and (B)s, Art. 102, put $x^2 = x - 1$ continually in (a); (a) becomes $(x - 1) + 3x - 2 = (A_1 x + B_1)(x - 1 - 2x + 1) = (A_1 x + B_1)(-x) = -A_1(x - 1) - B_1 x$, or $0 = 3 + A_1 - x(A_1 + B_1 + 4)$, whence Art. 92, $3 + A_1 = 0$, or $A_1 = -3$. Also $A_1 + B_1 + 4 = 0$, $\therefore B_1 = -1$.

Now differentiate (a), retaining (for brevity) only terms which do not vanish when $x^2 - x + 1 = 0$,

$$2x + 3 = (Ax + B)(2x - 1)(x - 1)^2 + A_1(x - 1)^2 \\ (A_1 x + B_1)2(x - 1),$$

when $x^2 = x - 1$. Making this substitution continually, to bring the equation to a linear form, we have, since $(x - 1)^2 = -x$,

$$2x + 3 = \{2A(x - 1) - Ax + B(2x - 1)\}(-x) \\ - 2A_1 x + 2A_1(x - 1) + B_1 2(x - 1) \\ = (Ax + 2Bx - 2A - B)(-x) - A_1 x + 2B_1 x - 2A_1 - 2B_1 \\ 0 = -2x - 3 - (A + 2B)(x - 1) + (2A + B)x \\ - (A_1 - 2B_1)x - 2A_1 - 2B_1.$$

This equation being of the required linear form, make the coefficient of x and the quantity independent of x each = 0. Art. 92.

$$0 = -2 + A - B - A_1 + 2B_1, \therefore A - B = 1,$$

$$0 = -3 + A + 2B - 2A_1 - 2B_1, \therefore A + 2B = -5,$$

$$B = -2, A = -1.$$

Hence the proposed fraction is equal to

$$-\frac{x + 2}{x^2 - x + 1} - \frac{3x + 1}{(x^2 - x + 1)^2} + \frac{1}{x - 1} + \frac{2}{(x - 1)^2}.$$

$$\int \frac{(x+2) dx}{x^2-x+1} = \frac{5}{\sqrt{3}} \tan^{-1} \frac{2x-1}{\sqrt{3}} + \frac{1}{2} \log(x^2-x+1),$$

Art. 85.

$$\begin{aligned} \int \frac{(3x+1) dx}{(x^2-x+1)^2} &= \frac{-3}{2(x^2-x+1)} + \frac{5}{2} \frac{2x-1}{3(x^2-x+1)} \\ &+ \frac{5}{3} \cdot \frac{2}{\sqrt{3}} \tan^{-1} \frac{2x-1}{\sqrt{3}}, \quad \text{Art. 85.} \end{aligned}$$

$$\int \frac{dx}{x-1} = \log(x-1)$$

$$\int \frac{dx}{(x-1)^2} = \frac{1}{x-1}, \quad \text{Art. 44,}$$

$$\begin{aligned} \therefore \int dx \frac{x^2+3x-2}{(x^2-x+1)^2(x-1)^2} &= \frac{7-5x}{3(x^2-x+1)} + \frac{2}{x-1} \\ &- \frac{25}{3\sqrt{3}} \tan^{-1} \frac{2x-1}{\sqrt{3}} + \log \frac{x-1}{(x^2-x+1)^{3/2}}. \end{aligned}$$

SECTION IX.

RATIONALIZATION.

105. THE last method of reducing functions of one variable to integrable forms which we have here to consider, is the method of Rationalization, which is a system of algebraical substitution, by which, for an *irrational algebraical* function, is found an equivalent which is rational, and therefore integrable by the preceding section.

106. *A rational function has a rational differential coefficient.* Every rational function of z may be reduced to the form

$$\frac{a + bz + cz^2 + \dots + kz^n}{a + bz + cz^2 + \dots + lz^m};$$

and it is clear the differentiation of this quantity cannot introduce fractional indices of z . It follows, that if x be any rational function of z , $\frac{dx}{dz}$ is a rational function of $z = R_1$; suppose, $\therefore dx = R_2 \cdot dz$, where R_2 is a rational function of z .

107. *A rational function of a rational function of x is a rational function of x .* For if ϕ, f , both indicate rational functions, $f x$ involves only integral powers of x , and $\phi(f x)$ involves only integral powers of $f x$: $\therefore \phi(f x)$ involves only integral powers of x , or is a rational function.

108. A universal method of rationalization cannot be given, as many irrational expressions are reduced to rational forms, by artifices peculiar to the cases in which they are applied. But the most general principle of rationalization may be stated as follows:—

Suppose that the expression to be rationalized is a rational function of an irrational function (I_1) of x , and of a rational function (R_1), so that the expression to be rationalized is

$$f(I_1, R_1);$$

where f indicates a rational function. Then assume, if possible, x equal to such a rational function of z , that I_x becomes equal to a rational function (R_z) of z . Then also, by Art. 106, $dx = R'_z dz$. Also, by Art. 107, $R_x = R''_z$, another rational function of z ;

$$\therefore f(I_x, R_x) dx = f(R_z, R''_z) R'_z dz.$$

But f indicates a rational function. Hence, by the article last referred to, $f(R_z, R''_z) R'_z dz$ is rational in z , or $f(I_x, R_x) dx$ is reduced to a quantity which is rational, and therefore integrable by the methods of the preceding section.

109. To rationalize $R_x \left(\frac{ax + b}{a_1x + b_1} \right)^{\frac{m}{n}} dx$, where R_x is a

rational function of x and m, n positive or negative integers. This is a particular case of the last article.

$$\text{Let } \frac{ax + b}{a_1x + b_1} = z^n, \therefore x = -\frac{a - a_1z^n}{b - b_1z^n} \dots\dots\dots (1).$$

or x is a rational function of z . Then by the last article,

$$R_x = R''_z, \quad dx = R'_z dz, \quad I_x = \left(\frac{ax + b}{a_1x + b_1} \right)^{\frac{m}{n}} = z^m,$$

and so the whole of the proposed expression is rationalized.

110. To rationalize $(a'x + b')^\mu (ax + b)^\nu dx$, where one of the three quantities

$$\mu, \nu, \text{ or } \mu + \nu \text{ is a positive or negative integer } \dots (2).$$

In the expression proposed to be rationalized in the last article, put $R_x = (a'x + b')^i$, where i is a positive or negative integer.

Put $a_1 = a', b_1 = b'$. Then the expression becomes

$$(a'x + b')^{i - \frac{\mu}{n}} (ax + b)^{\frac{\nu}{n}} dx,$$

which may be written

$$(a'x + b')^\mu (ax + b)^\nu dx,$$

where $\mu + \nu (= i)$ is an integer, or (2) is satisfied; and by (1),

$$\frac{ax + b}{a'x + b'} = z^n \dots\dots (3)$$

Next, let $R_x = (a'x + b')^i$, and in I_x let $a_1 = 0$, $b_1 = 1$. Then the expression rationalized becomes

$$(a'x + b')^i (ax + b)^{\frac{m}{n}} dx,$$

which, again, is of the form

$$(a'x + b')^\mu (ax + b)^\nu dx,$$

where one of the quantities μ or ν is an integer, and the condition (2) is satisfied. In this case (1) in the last article becomes

$$ax + b = z^n, \quad x = \frac{z^n - b}{a} \dots\dots (4)$$

111. To rationalize $x^p (ax^q + b)^{\frac{m}{n}} dx$.

Put $x^{\frac{1}{q}} = x$, $\therefore \frac{1}{q} \cdot x^{\frac{1}{q}-1} dx = dx$, $x^p = x^{\frac{p}{q}}$, and the

expression proposed to be rationalized becomes

$$\frac{1}{q} x^{\frac{p}{q} + \frac{1}{q} - 1} (ax + b)^{\frac{m}{n}} dx.$$

This can be rationalized by the last article, whenever $\frac{p}{q} + \frac{1}{q} - 1$ is an integer, and, therefore, $\frac{p+1}{q}$ an integer; or $\frac{p}{q} + \frac{1}{q} - 1 + \frac{m}{n}$ an integer, and, therefore, $\frac{p+1}{q} + \frac{m}{n}$ an integer.

The *First Criterion* of rationalization of

$$x^p (ax^q + b)^{\frac{m}{n}} dx,$$

is, that $\frac{p+1}{q}$ be a positive or negative integer, when (since $x^q = x$) we have to assume $ax^q + b = x^n$ by (4).

The *Second Criterion* of rationalization is, that $\frac{p+1}{q} + \frac{m}{n}$ be a positive or negative integer, when we have to assume $\frac{ax^q + b}{x^n} = z^n$ by (3).

112. The method of Art. 108 may be extended to several irrational functions $I_x^{(1)}, I_x^{(2)}, I_x^{(3)} \dots$ if it be possible to assume x such a rational function of z , that these irrational functions of x become equivalent to rational functions of z .

For instance, if the irrational function of x be

$$f \left\{ \left(\frac{a+bx}{a_1+b_1x} \right)^{\frac{1}{m}}, \left(\frac{a+bx}{a_1+b_1x} \right)^{\frac{1}{n}}, \left(\frac{a+bx}{a_1+b_1x} \right)^{\frac{1}{p}}, \&c. \right\} dx.$$

where $m, n, \&c.$, are integers.

$$\text{Put } \frac{a+bx}{a_1+b_1x} = z^{mnp\dots}, \quad \therefore x = -\frac{a-a_1z^{mnp\dots}}{b-b_1z^{mnp\dots}}$$

$$I_x^{(1)} = z^{mnp\dots}, \quad I_x^{(2)} = z^{mnp\dots}, \quad I_x^{(3)} = z^{mnp\dots},$$

dx is rational in z ; and so the whole expression may be rationalized.

SECTION X.

INTEGRATION OF FUNCTIONS OF SEVERAL VARIABLES.

113. We have hitherto considered the integration of functions of only one independent variable. The magnitude of a quantity may, however, depend upon the magnitudes of several other quantities, each of which is susceptible of independent and separate variation.

For instance, the cubic content of a right cylinder depends on two independent magnitudes, the altitude and the area of the base. Each of these magnitudes may be considered to vary independently of the other, for we may conceive the existence of any number whatever of cylinders with equal bases but different altitudes, and of any number of cylinders of equal altitudes but different bases.

Again, the content of a rectangular paralleliped is a function of three independent variables the lengths of three of its edges. The content of an oblique paralleliped is a function of five independent variables, namely, the lengths of three of its edges, and the inclinations of two of them to the third. The weight of a solid is a function of two independent variables, its volume and specific gravity. The time of vibration of a perfect pendulum vibrating in vacuo is a function of three independent variables—its length, the force of gravity, and the extent of the oscillation.

114. DEFINITION. The *Quadrature* of a finite continuous function of several independent variables having a limited range of values, is the sum of a series of different values of the function, each multiplied by the differences between the corresponding values of all the variables and their next preceding or succeeding values.

115. The *Multiple Integral* of such a function is the limit which its quadrature has when the differences of the independent variable approach zero, and their number infinity.

[These definitions are extensions of those of Articles 16 and 17.]

116. Let $f(z, y, x, w \dots)$ be a finite continuous function of any number (N) of independent variables. Suppose n_1 values given to z , n_2 values to y , n_3 values to x , &c. Then the total number of different values of the function will be the total number of different combinations of $n_1 + n_2 + n_3 + \dots$ different things taken N together.

Let $Z, z, Y, y, X, x \dots$ be the superior and inferior limits of the several variables. If Σ be understood to be the abbreviation of the words "sum of terms of the form of," the quadrature of

$$f(z, y, x, w, \dots) = \Sigma f(z, y, x, w \dots) \delta z \cdot \delta y \cdot \delta x \cdot \delta w \dots$$

where $\delta z, \delta y, \delta x, \delta w \dots$ indicate differences between successive values of the variables. Also,

$$\text{limit of } \Sigma f(z, y, x, w \dots) \delta z \cdot \delta y \cdot \delta x \cdot \delta w \dots$$

(when $\delta z, \delta y, \delta x, \delta w \dots$ approach the limit zero), is equal to the multiple integral of $f(z, y, x, w \dots)$ between the limits $Z, z, Y, y, X, x \dots$. This multiple integral is written

$$\int_z^Z \int_y^Y \int_x^X \dots f(z, y, x, w \dots) dz dy dx dw \dots$$

the sign \int being repeated as many times as there are independent variables.

117. *Multiple integrals found by successive integrations.*

Let $z_1, z_2, z_3 \dots y_1, y_2, y_3 \dots$ &c., be successive intermediate values of the variables between their limits. Also, let $\delta z_1, \delta z_2, \delta z_3 \dots \delta y_1, \delta y_2, \delta y_3 \dots$ &c., denote the successive differences of the values of the variables. The integral is the limit of the sum of terms of the form

$$f(z_m, y_n, x, \dots) \delta z_m \cdot \delta y_n \cdot \delta x, \dots$$

First. The sum of the terms in which z alone has different values, while the other variables have their first values, is

$$\{f(z_1, y_1, x_1 \dots) \delta z_1 + f(z_2, y_1, x_1 \dots) \delta z_2 + f(z_3, y_1, x_1 \dots) \delta z_3 + \dots\} \delta y_1 \delta x_1 \dots$$

of which the limit (since here z alone varies) is equal to

$$\text{limit of } \delta y_1 \delta x_1 \dots \int_z^Z f(z, y_1, x_1 \dots) dz.$$

This integral being taken between limits, involves only those limits, which may be functions of x, y, \dots or any other quantities whatever. But the variable intermediate values of z disappear (Art. 26) from the integral, which, therefore, takes the form $f_1(y_1, x_1, w_1 \dots)$, z being omitted.

Secondly. Add all the terms in which z alone varies, y having its second value, $x, w \dots$ as before their first values. The limits of the sum of these is

$$\begin{aligned} & \text{limit of } \delta y_2 \cdot \delta x_1 \dots \int_x^Z f(z, y_2, x_1, w_1 \dots) dz \\ &= \text{limit of } \delta y_2 \cdot \delta x_1 \dots f_1(y_2, x_1, w_1 \dots). \end{aligned}$$

Similarly for the terms in which $y_2, y_1, \&c.$ The sum of all these is

$$\begin{aligned} & \{ f_1(y_1, x_1, w_1 \dots) \delta y_1 + f(y_2, x_1, w_1 \dots) \delta y_2 \\ & \quad + f(y_3, x_1, w_1 \dots) \delta y_3 + \dots \} \delta x_1 \cdot \delta w_1 \dots \end{aligned}$$

of which the limit is (by reasoning with respect to y similar to the preceding with respect to z) the

$$\begin{aligned} & \text{limit of } \delta x_1 \cdot \delta w_1 \dots \int_y^Y f_1(x_1, w_1 \dots) dy \\ &= \text{limit of } \delta x_1 \delta w_1 \dots f_2(x_1, w_1 \dots), \end{aligned}$$

y being omitted from f_2 .

Continuing the process, $x, w \dots$ successively disappear by successive definite integrations; and the final result, or required multiple integral, is the result of as many successive integrations as there are independent variables.

Hence, where there are only two independent variables, if r be the last of the independent variables, this result is of the form

$$\begin{aligned} & \int_r^R f r dr = F(R) - F(r). \\ & \int_x^Z \int_y^Y f(z, y) dx dy = \int_y^Y dy \left\{ \int_x^Z f(x, y) dx \right\}; \end{aligned}$$

where there are three independent variables,

$$\begin{aligned} \int_x^Z \int_y^Y \int_x^X f(z, y, x) dz dy dx \\ = \int_x^X dx \left[\int_y^Y dy \left\{ \int_x^Z f(z, y, x) dz \right\} \right]. \end{aligned}$$

And, generally, a multiple integral is formed by integrating the proposed function with respect to one variable, as if the others were constant; substituting the limits of that variable; integrating the result with respect to another variable, as if the rest were constant; substituting the limits, and so on, till as many integrations have been performed as there are independent variables.

118. *Order of integration indifferent.* The sum of any number of quantities does not depend on the order in which they are added. Hence in the summation of the quadrature, the terms involving different values of any variable may be first collected, and the limit of their sum involves an integral with respect to that variable. Therefore, the variable with respect to which the first integration is performed, is indifferent. Similar reasoning applies to the other integrations.

COROLLARY.
$$\int_x^Y dy \left(\int_x^Z f(z, y) dz \right) \\ = \int_x^Z dz \left(\int_y^Y f(z, y) dy \right).$$

119. *The cubature of solids affords a very complete illustration of the foregoing principles.*

Let xOz , xOy , yOz be three planes perpendicular to each other; and let $ABCDabcd$, be a solid bounded by the curved surface $ABCD$, by a rectangle ac in the plane xOz , by two planes Ab , Dc parallel to the plane yOz , and two planes Ad , Bc parallel to the plane xOz .

Consider now the base ac of the solid divided into any number of rectangles, represented by dotted lines in the figure, and on these rectangles, as bases, let rectangular parallelepipeds be described, of which the sides cut the upper surface $ABCD$ in the curves shewn in the diagram.

If x, y, z be co-ordinates of any point (P) in the curved surface referred to rectangular axes Ox, Oy, Oz , the relation between x, y, z may be expressed by an equation

$$z = f(x, y),$$

in which z is supposed to be finite and continuous;

$$\text{and } pq = x, Oq = y, Pp = z.$$

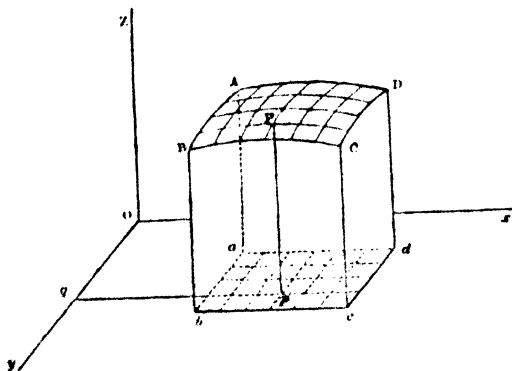

Let Pp be the altitude of one of the elementary parallelepipeds, δx and δy the length and breadth respectively of its base. Then the solid content of the parallelepiped is the product of these quantities, or $z \delta x \delta y = f(x, y) \delta x \delta y$.

Let $x_0, x_1, x_2, \dots, x_n,$

$y_0, y_1, y_2, \dots, y_n,$

be corresponding successive values of the co-ordinates, and $\delta x, \delta y,$ the common differences of the successive values of x and y respectively. Then it may be seen that the solid Ac contains parallelepipeds, of which (reckoning them in rows parallel to ab) the solid contents are

$$f(x_1, y_1) \delta x \delta y, f(x_1, y_2) \delta x \delta y, f(x_1, y_3) \delta x \delta y \dots f(x_1, y_n) \delta x \delta y,$$

$$f(x_2, y_1) \delta x \delta y, f(x_2, y_2) \delta x \delta y, f(x_2, y_3) \delta x \delta y \dots f(x_2, y_n) \delta x \delta y,$$

$$f(x_3, y_1) \delta x \delta y, f(x_3, y_2) \delta x \delta y, f(x_3, y_3) \delta x \delta y \dots f(x_3, y_n) \delta x \delta y,$$

.....

$$f(x_n, y_1) \delta x \delta y, f(x_n, y_2) \delta x \delta y, f(x_n, y_3) \delta x \delta y \dots f(x_n, y_n) \delta x \delta y.$$

Also, as will be proved hereafter, the more the number of these parallelipeds is increased, and their length and breadth diminished, the more nearly is their sum equal to the content of the solid AC. If the limits of the sums of the contents just written be taken in rows across the page, the result is

$$\begin{aligned} \text{limit } \{ & \delta x \int_{y_n}^{y_0} f(x_1, y) dy + \delta x \int_{y_n}^{y_0} f(x_2, y) dy + \dots \\ & + \delta x \int_{y_n}^{y_0} f(x_m, y) dy \} \\ & = \int_{x_m}^{x_0} \left\{ \int_{y_n}^{y_0} f(x, y) dy \right\} dx. \end{aligned}$$

If, however, the parallelipeds had been reckoned in rows parallel to the longest side of the page, that is, parallel to ab in the diagram, the limit of the summation would be

$$\int_{y_n}^{y_0} \left\{ \int_{x_m}^{x_0} f(x, y) dx \right\} dy.$$

And since both results represent the same solid content, they are equal.

SECTION XI.

QUADRATURE OF CURVES.

120. THE Integral Calculus is applied to the *rectification*, or determination of the *lengths* of curves; to the *quadrature*, or determination of *areas* of curves; the *complanation of surfaces*, or determination of their *superficies*; and the *curvature of solids*, or determination of their *volumes* or *contents*.

121. The methods of determining Quadratures and Cubatures are readily demonstrated by principles already laid down. Rectification and Complanation depend on geometrical theorems, hereafter given.

It has been shown, Art. 10, that if x and y be the rectangular co-ordinates of any point of a plane curve, X, Y , and x, y the co-ordinates of its extremities, the area included by it, and straight lines from its extremities parallel to the axes of x and y respectively, is given by the formulæ

$$\int_x^X x dy, \quad \text{or} \quad \int_y^Y y dx,$$

where it is supposed that x and y are always *positive* and *finite*, and to neither is assigned more than one value corresponding to any value of the other, between the limits X, Y, x, y .

122. *Quadrature of the Circle.* Let r be the radius of the circle; x, y , its co-ordinates at any point referred to the centre as origin of co-ordinates; then x and y are connected by the equation.

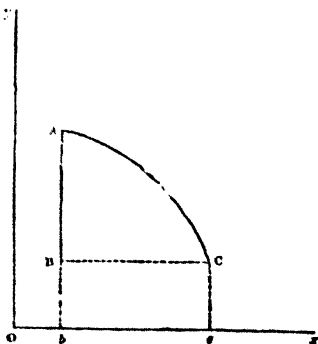

$$x^2 + y^2 = r^2;$$

$$\text{or, } y = (r^2 - x^2)^{\frac{1}{2}},$$

$$\int y dx = \int (r^2 - x^2)^{\frac{1}{2}} dx$$

$$= (r^2 - x^2)^{\frac{1}{2}} x + \int \frac{dx}{(r^2 - x^2)^{\frac{1}{2}}} \quad (\text{integrating by parts}),$$

$$\text{Now } \int (r^2 - x^2) dx = (r^2 - x^2)^{\frac{1}{2}} x$$

$$+ r^2 \int \frac{dx}{(r^2 - x^2)^{\frac{1}{2}}} - \int \frac{r^2 - x^2}{(r^2 - x^2)^{\frac{1}{2}}} dx.$$

The last integral on the second side of this equation is identical with the integral on the first side. Therefore, transposing and integrating the remaining integral by Art. 56,

$$\int (r^2 - x^2) dx = \frac{1}{2} x (r^2 - x^2)^{\frac{1}{2}} + \frac{1}{2} r^2 \sin^{-1} \frac{x}{r}.$$

If $Oc = X$, and $Ob = x$, we have to take this result between limits X and x , to find the area Λbc ;

$$\begin{aligned} \Lambda bc &= \frac{1}{2} X (r^2 - X^2)^{\frac{1}{2}} - \frac{1}{2} x (r^2 - x^2)^{\frac{1}{2}} \\ &\quad + \frac{1}{2} r^2 \sin^{-1} \frac{X}{r} - \frac{1}{2} r^2 \sin^{-1} \frac{x}{r}. \end{aligned}$$

If it were required to find the area of a quadrant, B , would be supposed to meet Oy , Ox , respectively, and therefore $X = r$, $x = 0$. Therefore, since $\sin^{-1} 0$ (or the angle ϕ which the sine is 0) = 0, and $\sin^{-1} 1 = \frac{\pi}{2}$,

$$\text{quadrant} = \frac{\pi}{4} r^2.$$

Therefore, area of whole circle = πr^2 .

123. *Area of Ellipse.* The equation to the ellipse referred to the major axis, and a line at right angles to it at its extremity as axes of co-ordinates, is

$$y = \frac{b}{a} (2ax - x^2)^{\frac{1}{2}},$$

where a is the semi-axis major, and b the semi-axis minor.

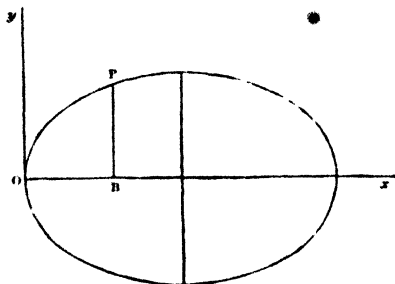

$$\begin{aligned} \int y dx &= \int \frac{b}{a} (2ax - x^2)^{\frac{1}{2}} dx \\ &= \frac{1}{2} ab \cos^{-1} \frac{a-x}{a} - \frac{b(a-x)}{2a} (2ax - x^2)^{\frac{1}{2}} \dots (1.) \end{aligned}$$

When $x = 0$ the preceding expression vanishes. It may, therefore, be supposed to be taken between the limits 0 and x ; consequently, if $OB = x$, the expression is the value of the area PBO.

When $a = b$ the ellipse becomes a circle, and the expression (1) for the area becomes

$$\frac{1}{2} a^2 \cos^{-1} \frac{a-x}{a} - \frac{a-x}{2} (2ax - x^2)^{\frac{1}{2}} \dots (2)$$

Hence, if $OP'M$ be a circle having the same centre C with the ellipse OPM , and OM , the diameter of the circle, be also the major axis of the ellipse, we have, comparing (1) and (2),

$$\frac{\text{area } OP'B}{\text{area } OPB} = \frac{a}{b}.$$

It appears also from (1), that the area OPB is proportional to b . Hence, if any number of concentric ellipses were

described on the same axis major, the areas of them having the same base, OB, would be in the proportion of the several minor axes.

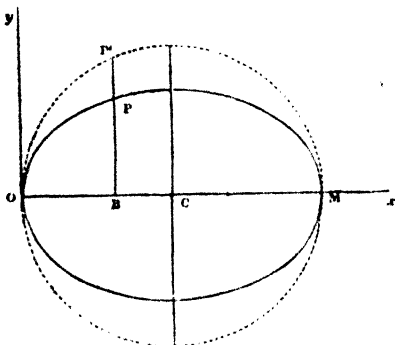

The area of a quadrant of the ellipse is found from (1), by putting $x = a$, to be

$$\frac{1}{4} ab \cos^{-1} 0 = \frac{\pi}{4} ab.$$

Hence the area of the ellipse $= \pi ab$.

124. *Quadrature of curves referred to oblique co-ordinates.* The method of obtaining, in Art. 19, the quadrature of curves referred to rectangular co-ordinates, consists in dividing the

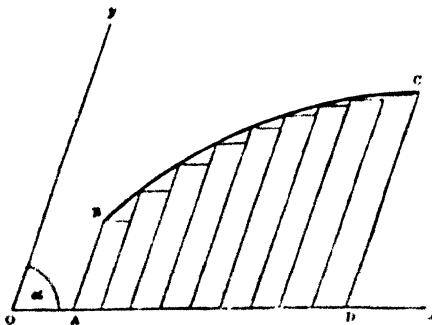

area by rectangles, and taking the limit which their sum has when their breadth is indefinitely diminished and their number indefinitely increased.

Similarly, if an area, $ABCD$, bounded by the curve BC , and three straight lines, of which BA is parallel to CD , be divided by parallelograms upon AD having sides parallel to CD , the limit of their sum is the area $ABCD$. Also, let the curve be referred to oblique axes of co-ordinates Oy , Ox , inclined to each other at an angle α . If δx and y be the lengths of two sides of one of the parallelograms, $y \sin \alpha$ is its altitude, and $y \sin \alpha \delta x$ is its area; whence it is easily seen, that the area $ABCD = \int y \sin \alpha dx$, taken between proper limits.

125. *Quadrature of the Hyperbola.* Let the hyperbola, of which A is the vertex, be referred to its asymptotes Ox , Oy ,

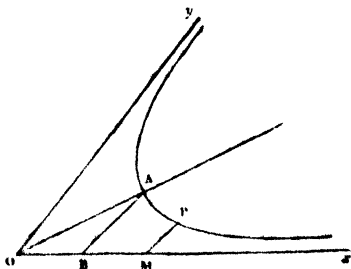

inclined to each other at an angle α , as axes. Draw AB parallel to Oy , and let $OB = c$. The equation to the hyperbola is $yx = e^2$. $Om = x$.

$$\begin{aligned} \text{Area } ABPM &= \sin \alpha \int_c^x y dx = \sin \alpha \int_c^x \frac{e^2}{x} dx \\ &= \sin \alpha e^2 \log \frac{x}{c}. \end{aligned}$$

126. *Quadrature of the Witch of Agnesi.* In the last example, as x increases, the area increases indefinitely; and, therefore, the whole area between the curve and the asymptote is infinite. There are, however, curves in which the area between an infinite branch of the curve and its asymptote are

finite. The "witch," or "versiera" of Donna Maria Agnesi, is an instance. Let AB be a diameter of a circle $= a$, AC a tangent, P any point in the curve, $AM = x$; AB , AC being the axes of x and y respectively.

The curve is defined by the relation rectangle $PA =$ rectangle DB .

The equation to the curve will be found to be $xy^2 = a^2(a - x)$.

$$\text{Now, } \left(\frac{a-x}{x}\right)^{\frac{1}{2}} = \frac{a-x}{(ax-x^2)^{\frac{1}{2}}}$$

$$= \frac{1}{2} \frac{a-2x}{(ax-x^2)^{\frac{1}{2}}} + \frac{\frac{1}{2}a}{\left\{\frac{1}{2}a^2 - \left(\frac{1}{2}a-x\right)^2\right\}^{\frac{1}{2}}};$$

$$\therefore \int y dx = a \int \left(\frac{a-x}{x}\right)^{\frac{1}{2}} dx$$

$$= a(ax-x^2)^{\frac{1}{2}} + \frac{1}{2}a^2 \cos^{-1} \frac{\frac{1}{2}a-x}{\frac{1}{2}a}.$$

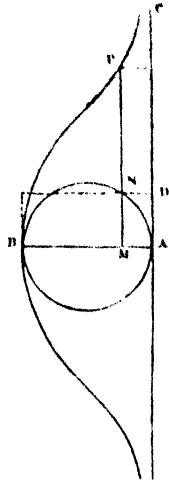

Arts. 44 and 50.

This expression is to be taken between limits $x = a$ and $x = x$, to give the area PBM .

The area between AC , AH , and the curve, is the limit which the result thus obtained has when x has the limit 0. This evidently is found by taking the expression for the integral between limits $x = a$ and $x = 0$;

$$\therefore \text{required area} = \{\cos^{-1}(-1) - \cos^{-1}1\} \frac{1}{2}a^2 = \frac{1}{2}\pi a^2.$$

The whole area between the asymptote and the whole curve on *both* sides of AB , is double the preceding, or $= \pi a^2$; and, consequently, is four times the area of the circle.

127. *Quadrature of the Cissoid of Diocles.* This curve, invented by Diocles, a Greek mathematician, about the sixth century, and used for finding two mean proportionals, resembles the curve last considered in several respects. It affords another instance of a finite area included between an infinite curve and its asymptote.

The cissoid may be defined by Newton's method of tracing

it. The arms of a bent lever are at right angles to each other, and the end of one of them slides along a straight line, while the other is always in contact with a point of which the distance from the straight line is equal to the length of the first arm. The angle of the lever traces out the cissoid.

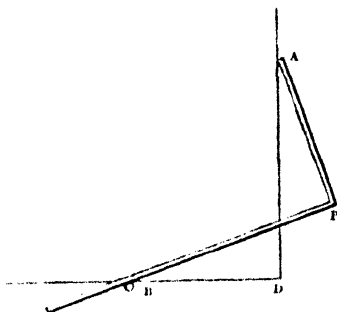

Let B be the fixed point. Then, if $AP = BD$, and the end A of the lever move along a straight line, while PC remains in contact with B, the cissoid is the locus of P.

Let $AC = a$, $AB = x$, $PB = y$. The equation to the cissoid will be found to be

$$y^2(a - x) = x^3.$$

$$\int y dx = \int x^{\frac{3}{2}} \frac{dx}{(a - x)^{\frac{1}{2}}}$$

$$= -2(a - x)^{\frac{1}{2}} x^{\frac{3}{2}} + 3 \int (a - x)^{\frac{1}{2}} x^{\frac{1}{2}} dx$$

(integrating by parts).

$$\text{Also, } (a - x)^{\frac{1}{2}} x^{\frac{1}{2}} dx = (ax - x^2)^{\frac{1}{2}} dx$$

$$= \left\{ \left(\frac{1}{2} a \right)^2 - \left(x - \frac{1}{2} a \right)^2 \right\}^{\frac{1}{2}} dx,$$

which is of a form which has been already integrated (Art. 83);

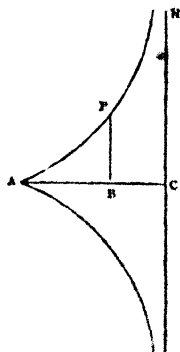

$$\therefore \int y dx = -2(a-x)^{\frac{3}{2}} x^{\frac{3}{2}} + 3\left(\frac{1}{2}x - \frac{1}{2}a\right)(ax-x^2)^{\frac{1}{2}} + \frac{3}{8}a^2 \text{vers}^{-1} \frac{x}{\frac{1}{2}a}.$$

For the whole area between AC, CH, and the curve, it appears by the same considerations as in the last article, that this integral is to be taken between the limits $x=a$ and $x=0$, when

$$\int y dx = \frac{3}{8}a^2 \{ \text{vers}^{-1} 2 - \text{vers}^{-1} 0 \} = \frac{3}{8}a^2 \pi.$$

The whole area included by both branches of the curve and the asymptote is double this, or $\frac{3}{4}\pi a^2 =$ three times the area of the circle of which AC is the diameter.

128. *Polar co-ordinates.* Let the position of any point in a plane curve be referred to polar co-ordinates, namely, the length (r) of the straight line drawn from the point in the curve to the *pole*, an assigned point in the plane of the curve; and the inclination (θ) of that line, to some fixed line in the same plane passing through the pole. Let S be the origin or pole, P the point in the curve, $SP = r$, which is called the *radius vector*, and Sx the assigned fixed line from which the angle $PSx = \theta$ is measured. If P be also referred to rectangular co-ordinates of which Sx and Sy perpendicular to Sx are axes, it is easily seen by trigonometry that

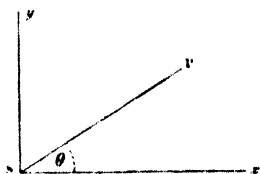

$$r \sin \theta = y, \quad r \cos \theta = x.$$

Suppose now that it is desired to determine the *sectorial* area included between the radii vectores at two points in a curve and the arc between them. When a curve is referred to rectangular co-ordinates x and y , the integrals $\int y dx$ or $\int x dy$ between limits determine the area included by a curve and straight lines parallel to the axes. The relation between such areas and a sectorial area is established by the following proposition.

129. *Sectorial area in terms of rectangular co-ordinates.*
 Let PQ in either of the accompanying figures be the curve, which is taken of such length that it is not met at two points by any one of its co-ordinates, and PSQ the required sectorial area.

(1.)

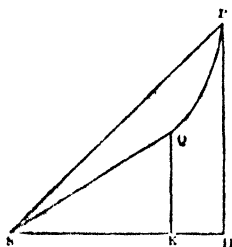

(2.)

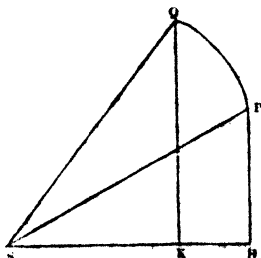

Let $SK = x$, $SH = X$, $QK = y$, $PH = Y$. It is evident that

$$PQKH = \int_x^X y dx.$$

Also, triangle $QKS = \frac{1}{2}yx$, triangle $PSH = \frac{1}{2}XY$. Also,

Fig. (1), $PQS + QSK + QKHP$ make up the whole PSH ;

$$\therefore PQS = \frac{1}{2}(XY - xy) - \int_x^X y dx.$$

Fig. (2), $PQS + PSH$ makes up the whole figure, as does also $QKHP + QSK$. Therefore,

$$- PQS = \frac{1}{2}(XY - xy) - \int_x^X y dx.$$

Hence in both cases, PQS , the sectorial area, is, by Art. 34, equal to

$$\pm \frac{1}{2} \left(\int_x^X y dx - \int_y^Y x dy \right)$$

130. *Sectorial area expressed by polar co-ordinates.* In the last article the sectorial area was found to be equal to $\frac{1}{2}(\int xdy - \int ydx)$ between proper limits.

Putting $x = r \cos \theta$, $y = r \sin \theta$,

$$dx = dr \cos \theta - r \sin \theta d\theta,$$

$$dy = dr \sin \theta + r \cos \theta d\theta:$$

$$\therefore xdy - ydx = r^2 d\theta;$$

$$\therefore \text{sectorial area} = \frac{1}{2} \int r^2 d\theta,$$

where the limits of θ are the angles between the prime radius vector and the radii vectores which bound the required area.

131. *The same result may be deduced directly from geometrical considerations.* Divide the sectorial area by radii vectores r_1, r_2, r_3, \dots between the extreme radii vectores R, r , with S as centre, and at distances R, r_1, r_2, \dots describe circular

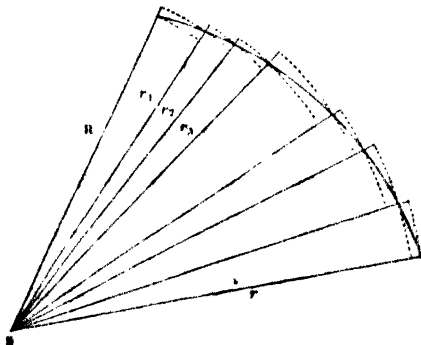

arcs represented in the figure by dotted lines. The sectorial area is less than the sum of the sectors of which the arcs are without it, and less than the sum of the sectors of which the arcs are within it. The area of a circular sector, of which the radius is r and the angle $\delta\theta$, is $\frac{1}{2} r^2 \delta\theta$. Therefore, the required sectorial area is

$$\text{less than } \frac{1}{2} (R^2 \delta\theta_1 + r_1^2 \delta\theta_2 + r_2^2 \delta\theta_3 + \dots) \quad (1.)$$

$$\text{greater than } \frac{1}{2} (r_1^2 \delta\theta_1 + r_2^2 \delta\theta_2 + r_3^2 \delta\theta_3 + \dots) \quad (2.)$$

where $\delta\theta_1, \delta\theta_2 \dots$ are the angles between the radii. Now, r is a finite continuous function of θ . Therefore, by Art. 20, the above expressions (1) and (2) have the same limit, and as the sectorial area is between them, it is equal to that limit, or
 sectorial area $= \frac{1}{2} \int_{\theta_1}^{\theta_2} r^2 d\theta = \int_{\theta_1}^{\theta_2} \int_0^r r dr d\theta$, where Θ, θ are the inclinations of R, r respectively to the prime radius.

132. *Quadrature of the spiral, $r = a \sin n\theta$, where n is an integer.* This curve has $2n$ similar loops, and, therefore, the whole area contained by it is equal to $2n$ times the area of one loop.

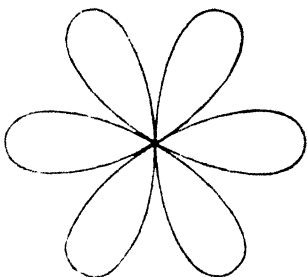

$$\frac{1}{2} \int r^2 d\theta = \frac{1}{2} a^2 \int \sin^2 n\theta d\theta.$$

Integrating by parts,

$$\begin{aligned} \int \sin n\theta \cdot \sin n\theta d\theta &= -\frac{1}{n} \cos n\theta \sin n\theta + \int \cos^2 n\theta d\theta \\ &= -\frac{1}{n} \cos n\theta \sin n\theta + \int (1 - \sin^2 n\theta) d\theta. \end{aligned}$$

Therefore, transposing and dividing by 2, we have

$$\begin{aligned} \int \sin^2 n\theta d\theta &= \frac{1}{2} \left(\theta - \frac{1}{n} \cos n\theta \sin n\theta \right), \\ \therefore \frac{1}{2} \int r^2 d\theta &= \frac{1}{4} a^2 \left(\theta - \frac{1}{n} \cos n\theta \sin n\theta \right). \end{aligned}$$

From the equation to the curve, it is evident that a is the greatest value which r can have, and that then it is drawn bisecting one of the loops. Since $r = a$ when $n\theta = \frac{1}{2}\pi$, and $r = 0$ when $\theta = 0$, the half loop lies between the two positions of the radius vector corresponding to those values of θ . Therefore, taking the preceding expression for the area between limits $\frac{\pi}{2n}$ and 0 of θ ,

$$\text{area of half loop} = \frac{1}{4} a^2 \cdot \frac{\pi}{2n}.$$

The whole area is $4n$ times this, or $= \frac{\pi a^2}{2}$, which is half the area of the circle circumscribing the curve. The result is remarkable, as it is the same whatever the number of loops of the curve.

183. *Of curves, such that one co-ordinate has more than one value for one value of the other co-ordinates, the quadratures are found by dividing the curve into several parts, each of which is of such length that it is not met at two points by any one of its co-ordinates, and determining by the preceding methods the quadrature corresponding to each such part.*

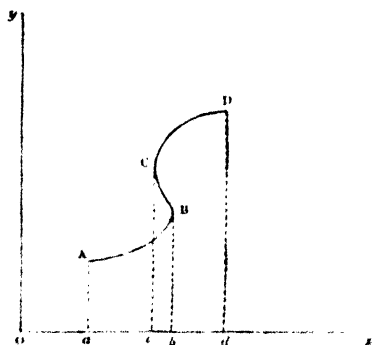

For instance, in the accompanying figure the ordinates parallel to Oy have three values for each value of x between Oc and Ob , where Cc , Bb , are ordinates touching the curve at C and B respectively. But the areas $AabB$, $CcbB$, $CedD$, may each be found by the preceding methods. Also, the required area

$$ABCDda = AabB + bBDD, \text{ and } bBDD = cCDd - cCBb;$$

$$\therefore \text{required area} = AabB + CcdD - cCBb.$$

It may easily be seen that the generalization of this rule is, to divide the area into as many parts as the curve has parts, alternately receding from and approaching the axis of y ; to find each of these parts by integrating ydx between corresponding limits; and to take the difference between the

sum of the areas under receding parts of the curve, and the sum of the remaining areas.

184. *Area in terms of the length of the curve.* The parts of the curve which recede from Oy are those for which x increases as the length of the curve measured from its extremity nearest to Oy increases; and where, consequently, if s denote the length of the curve, $\frac{dx}{ds}$ is positive. In the other parts of the curve $\frac{dx}{ds}$ is negative.

$$\text{Now, } \int y dx = \int y \frac{dx}{ds} ds \text{ (Art. 38).}$$

If, then, s_1, s_2, \dots, s_n , be the respective lengths of the curve from its commencement up to the points where $\frac{dx}{ds}$ changes sign,

$$\int_0^{s_1} y \frac{dx}{ds} ds, \int_{s_1}^{s_2} y \frac{dx}{ds} ds, \&c.$$

are the component parts of the required area. But the alternate parts are to be subtracted from the sum of the rest. The result will be the algebraical sum of all the parts, since $\frac{dx}{ds}$ is alternately positive and negative.

Therefore, the required area (S being the whole length of the curve)

$$\begin{aligned} &= \int_0^{s_1} y \frac{dx}{ds} ds + \int_{s_1}^{s_2} y \frac{dx}{ds} ds + \dots \\ &+ \int_{s_n}^S y \frac{dx}{ds} ds = \int_0^S y \frac{dx}{ds} ds, \end{aligned}$$

if $y \frac{dx}{ds}$ be a continuous finite function of s . By the nature of the quantities y can only have one value for each value of s ; and, if the curvature be continuous, $\frac{dx}{ds}$ has only one value for each value of s ; so that the result of integrating $y \frac{dx}{ds} ds$ is necessarily definite.

185. *Negative ordinates.* In investigating areas of curves,

it has been assumed that the co-ordinates are positive. When one of the co-ordinates is negative, the processes described in the preceding articles will require modification.

By the principles of analytical geometry the symbols + and - prefixed to symbols of length, are interpreted to indicate contrary directions of measurement; so that if from any point in a line curved or straight a length measured off along the line towards one of its extremities be reckoned positive, a length measured from any point in the line along it towards its other extremity is affected by the negative sign. But no such convention applies to areas which are considered essentially positive.

If the curve be referred to rectangular co-ordinates, and y do not change sign between the limits, and x be positive or negative, $\int y dx$ is of the same sign as y , if the limits be taken in the same order as was prescribed (Art. 10) for positive co-ordinates; that is, if x increase *positively* in passing from its value which is the inferior limit to its value which is the superior limit. This is shewn as follows:—

$\int y dx$ is the limit of the sum of terms of the form $y \delta x$, where δx , the increment of x , is positive, since x increases *positively*, in passing from the inferior to the superior limit; consequently, $y \delta x$ has the same sign as y , and $\int y dx$ has the same sign.

It follows, that for all areas on the negative side of the axis of x , $\int y dx$ is negative and $\int y dx$ is positive for all areas on the positive side of the axis of x .

In order, then, to determine the whole area bounded by a curve, of which part is on the positive and part on the negative side of the axis of the independent variable, the two parts must be determined by separate integrations, and the negative part must be added *positively* to the positive part.

136. *Negative polar co-ordinates.* In determining the sectorial area of curves referred to polar co-ordinates, $\int r^2 d\theta$ is to be taken between limits such that θ increases *positively* in passing from its value at the inferior to its value at the superior limit. Hence it appears, by similar reasoning to that used in the last article, that, whether θ be positive or negative, $\int r^2 d\theta$ is positive.

SECTION XII.

CUBATURE OF SOLIDS.

137. LET a solid, $ABCcdab$, be bounded by a curved surface $abcd$ and by five bounding planes, viz.:—by a rectangle, of which AB , BC are two sides, and by four planes dA , aB ,

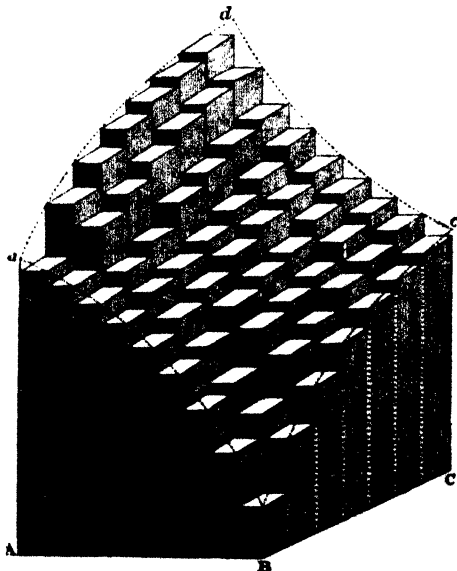

Bc , Cd , perpendicular to the plane of the rectangle, passing through its sides and meeting the curved surface in four plane curves ab , bc , cd , da .

Let the curved surface be referred to rectangular coordinates (x, y, z) of which the axes are parallel to BA , Bb , BC respectively, and let the surface be such that each

co-ordinate has but one value for each value of the other co-ordinates.

Draw within the solid planes, parallel to the bounding planes and cutting off within the solid, a number of rectangular parallelepipeds, of which, since they are within the solid, the total content is less than the volume V of the solid.

Add, now, a set of rectangular parallelepipeds (not shewn in the figure), within which the curved surface wholly lies, and which are formed by the above-mentioned parallelepipeds produced. It is clear, that as these additional parallelepipeds are increased in number and diminished in magnitude, their sides approach continually closer to the curved surface; and that, consequently, their volume (v) may be diminished without limit.

V is greater than the solid content of the first set of parallelepipeds, and less than that solid content $+ v$.

Therefore, V lies between two quantities, of which the difference may be diminished indefinitely. *A fortiori*, the difference between either of them and V may be diminished indefinitely.

Let the lengths of edges of one of the parallelepipeds be δx , δy ; z its altitude; $z \delta x \delta y$ its volume. Let $\Sigma z \delta x \delta y$ denote the sum of the volumes of the parallelepipeds within the solid V ,

$$\begin{aligned} V &= \text{limit of } \Sigma z \delta x \delta y \\ &= \iint z \, dx \, dy \quad (\text{Art. 117}) \\ &= \iiint dx \, dy \, dz, \end{aligned}$$

the integral being taken between limits which depend on the boundaries of the solid.

In the figure, for the sake of simplicity, the internal planes are supposed to be equidistant.

138. *The limits of integration for the cubature of a solid may be investigated by the following method of exhibiting the result just obtained.* Let $MM'NN'$ be an element of the curved surface, $QQ'RR'$ its projection on the plane of xy . Let $QQ_1 = \delta x$, $QR = \delta y$. In the limit the solid $M'R$ is a prism, of which the altitude is z and the area of the $dx \, dy$;

$$\therefore dV = z \, dx \, dy.$$

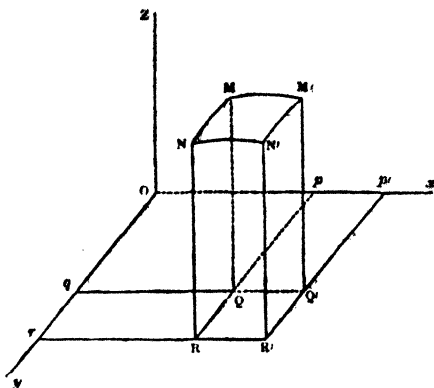

Suppose the equation to the curved surface gives $z = f(x, y)$. Then

$$dV = \iint f(x, y) dx dy.$$

In this expression take first (Art. 117) y constant, and integrate $f(x, y) dx dy$ with respect to x . The result is the limit of the sum of the prisms, of which the bases are between the parallel lines qQ' , rR' . Let $x = X$ and $x = x$ be co-ordinates of the extremities of their lengths in the solid;

$$\therefore dy \int_x^X z dx$$

is the analytical expression of the content of the row of prisms just defined.

In order to find V , we have to add together this and the parallel rows of prisms, and to take the limit of their sum. If Y, y be co-ordinates of the bounding planes parallel to zx ,

$$V = \int_y^Y \int_x^X z dx dy.$$

189. *Solid bounded laterally by a curved surface.* We have in the preceding articles taken the most simple case of cubature, that in which the solid is bounded laterally by four

planes. The limits of x and y are then the same for every point of the solid, and independent of each other. In this case the integrations are comparatively easily effected. If, however, the solid be bounded laterally by curved surfaces, the extreme values of x and y are no longer independent, but are connected by the equations to these curved surfaces.

Let X, x be constant quantities; Y, y two functions of the variable x ; Z, z two functions of the two variables x and y . Then it may be shewn that if the volume included between the six surfaces, of which the equations are respectively

$$x = X, x = x, y = Y, y = y, z = Z, z = z,$$

be designated by V ,

$$V = \int_x^X \int_y^Y \int_z^Z dx dy dz.$$

From the equations to the six surfaces it will be seen that V is the volume of a solid, De , bounded by two cylindrical surfaces $ECcc$ and $FDdf$, of which the traces are Aa and Bb respectively; by two parallel planes cd , ED , of which AB, ab are the intersections with xz , and by two curved surfaces $CDdc$ and $Eeff$.

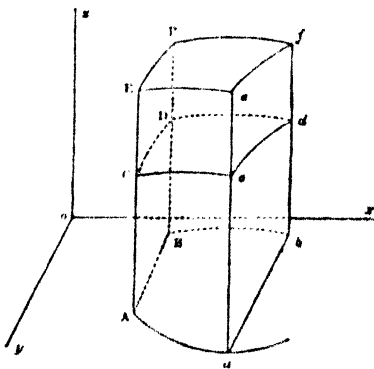

140. *Hyperbolic paraboloid.* The equation to the surface of the hyperbolic paraboloid is $xy = cz$ when c is a constant. The general expression for the volume becomes

$$V = \frac{1}{c} \iint xy dy dx.$$

Let it be required to find the volume contained by this surface, the plane xy , and a cylinder of which the base is a circle of radius r , and the axis parallel to the axis of x .

Integrating first with respect to y between limits Y, y ,

$$V = \frac{1}{2c} \int (Y^2 - y^2) x dx.$$

Now the equation to the cylinder is $(x-a)^2 + (y-b)^2 = r^2$, which gives two values of y for each value of x . One of these values is the superior, and the other the inferior limit of the integration just performed; or,

$$Y = b + \{r^2 - (x-a)^2\}^{\frac{1}{2}}, \quad y = b - \{r^2 - (x-a)^2\}^{\frac{1}{2}};$$

$$\therefore Y^2 - y^2 = 4b \{r^2 - (x-a)^2\}^{\frac{1}{2}};$$

$$\therefore V = \frac{2}{c} \int \{r^2 - (x-a)^2\}^{\frac{1}{2}} x dx.$$

The extreme values of x are evidently $a+r$ and $a-r$. Taking the last integral between those limits, it will be found that $V = \frac{abr^2\pi}{c}$

141. *Solids of revolution* are those generated by the revolution of a plane figure about a fixed axis. Let the revolution of a curve AB about an axis through A generate the surface of such a solid, and let the equation to AB be $y = f(x)$, where x is measured from A along the axis of revolution.

It is clear that the volume of the solid is the limit of the sum of a number of elementary cylinders having the same axis. Let δx be the altitude of one of these cylinders, y the radius of its base; $\therefore \pi y^2$ is the area of the base; and that area multiplied by the altitude, or $\pi y^2 \delta x$, is the volume of the elementary cylinder. Therefore, the required volume is equal to

$$\text{the limit of } \Sigma(\pi y^2 \delta x) = \pi \int y^2 dx.$$

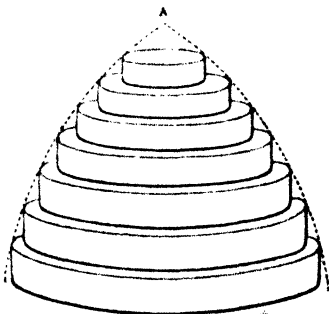

142. *Content of a cone.* A cone is generated by the rotation of a triangle about one of its sides. Let $y = ax$ be the equation to the straight line generating the conical surface, where a is the tangent of the angle at which that straight line is inclined to the axis of revolution. The content of the cone $= \pi a^2 \int x^2 dx = \frac{1}{3} \pi a^2 x^3$ (taking the integral between limits 0 and x) $= \frac{1}{3} \pi y^2 x^2$, or the solid content of a cone is one-third the area of the base multiplied by the altitude = one-third of the content of the cylinder having the same base and altitude.

143. *Paraboloid of revolution.* The surface generated by the revolution of a parabola about its axis, is called a paraboloid of revolution. To find the solid bounded by such a surface, and a plane perpendicular to the axis, we must put $y^2 = ax$, the equation to a parabola.

The required volume $= \pi a \int x dx = \frac{1}{2} \pi a x^2$.

144. *Solid of revolution through any angle.* The quantity $\pi \int y^2 dx = 2\pi \iint y dy dx$. Also it is evident, that if the generating figure turn through an angle ϕ instead of 2π , the solid content generated is equal to

$$\phi \iint y dy dx.$$

145. *Limits of the preceding integrals.* If the generating figure have not for one of its boundaries the axis of revolution, but a curved line, of which the equation is $y = \phi x$, the limits of integration of $y dy$ are $\int x$ and ϕx . Similarly, if it be required to find the solid generated by the portion of such a figure of which the extreme co-ordinates are two particular values X and x of x , the integral with respect to x must be taken between those limits.

146. *Content of a solid of revolution in terms of its area.* Let \bar{y} be some constant quantity. Then if \bar{y} were equal to the greatest value of the variable y , $\iint \bar{y} dy dx$ would obviously be greater than $\iint y dy dx$. If \bar{y} were equal to the least value of the variable y , $\iint \bar{y} dy dx$ would be less than $\iint y dy dx$. There is, therefore, some value of the con-

stant \bar{y} between the greatest and least values of y , for which $\iint \bar{y} dy dx$, or

$$\bar{y} \iint dy dx = \int y dy dx.$$

(By Pappus's Theorems, \bar{y} is shown to be the distance of the centre of gravity of the generating figure from the axis of revolution.) The integral on the first side of the preceding equation expresses the area of the generating figure. Therefore, from the last article, the content of the solid of revolution through an angle ϕ , is equal to

$$\bar{y} \phi \times \text{area of generating figure,}$$

where \bar{y} is a line less than the greatest and greater than the least distances of points in the generating figure from the axis of revolution.

147. *Cubature of a solid of revolution by polar co-ordinates.*

Let $PSA = \theta$, $PS = r$ be the co-ordinates of any point P in a plane figure referred to the pole S . The area of an element PP' of the figure is (by Article 131) $r d\theta dr$. By the last article, the solid generated by the revolution of PP' about SM through an angle ϕ , is $r d\theta dr \times$ a distance which is ultimately equal to the distance of P from SM , which is equal to $r \cos \theta$. Therefore, by the

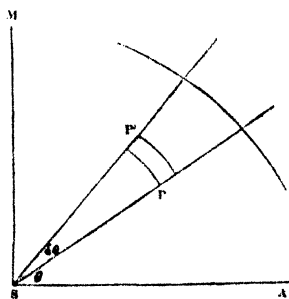

last article, the elementary solid $= \phi r \cos \theta d\theta dr$, and the content of a solid of revolution generated by a sectorial area revolving, about an axis fixed with respect to it, through an angle ϕ , is equal to

$$\phi \iint r \cos \theta d\theta dr.$$

148. *Cubature by polar co-ordinates.* Every solid may be generated by the rotation about a fixed axis of a generating figure of which the form is variable. Suppose the angle of rotation to be ϕ . Then any solid may be considered to be generated by the rotation of a figure bounded by a curve of which the equation is $r = f(\phi, \theta)$.

When the generating figure has revolved through an angle $\phi + \delta\phi$, the equation to this curve becomes

$$r = f(\phi + \delta\phi, \theta).$$

The solid bounded by the two corresponding generating figures may be always so taken as to be within that generated by the rotation of one of them, and partly without that generated by the rotation of the other, through an angle $\delta\phi$. Hence, ultimately, the required content is equal to that due to the rotation of either figure; and, therefore, by the last article, is equal to $\delta\phi \iint r \cos \theta d\theta dr$. Hence, the whole required solid content is equal to

$$\iiint r \cos \theta d\theta dr d\phi.$$

149. *Cubature by polar co-ordinates by direct investigation.*

Let an assigned point S be the pole; let SRQ be an assigned plane, and SR an assigned straight line in that plane. The position of a point P may be determined by the length (r) of SP, the radius vector, θ , the angle at which SP is inclined to the plane, and ϕ , the angle at which the projection of SP on the plane is inclined to the assigned line SR.

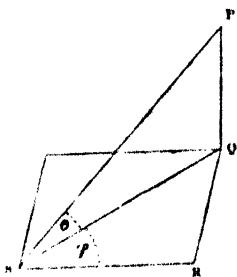

(This is evidently similar to a determination of the distance of a point above the earth by its distance (r) from the observer, its angular elevation above the horizon (θ), and (ϕ) its "bearing" north or south.)

In order to find the solid content bounded by a curved surface and planes meeting it and passing through the pole S, suppose that, by a number of planes passing through the pole, the solid is divided into a number of *pyramids* having all their vertices in S.

The required solid content is greater than the sum of the pyramids within it, and less than the sum of a corresponding set of pyramids partially external to it; and as the difference between these two sums may be diminished indefinitely, the limit of either of them is the required solid content.

Let P, P' be two adjacent points in the curved surface;

$PSp = \theta, pSR = \phi,$

co-ordinates of P ;

$\theta + \delta\theta, \phi + \delta\phi,$

co-ordinates of P' .

Draw through P, P' respectively, the

planes PQS_p and $P'Sq'Q'$, perpendicular to the plane in which ϕ is measured. Also, draw the planes $P'QS$ and $PQ'S$, respectively perpendicular to the last-mentioned planes through P, P' . Therefore the angle $PSQ = \delta\theta$ and $pSq' = \delta\phi$.

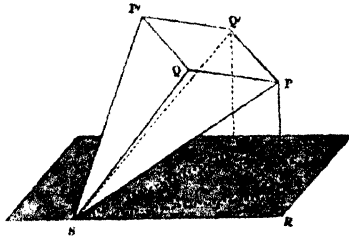

Ultimately, $P'S = PS = r$, and the pyramid on the rectangular base $P'P$ is an element of the required solid. Now the content of such a pyramid = $\frac{1}{3}$ area of base \times altitude. $Q'P = q'p = Sp \cdot \delta\phi$ ultimately (assuming the proof given hereafter, that the lengths of a chord and its arc are ultimately equal). But $pS = r \cos \theta$, $\therefore PQ' = r \cos \theta \delta\phi$ ultimately.

Similarly, $QP = r \delta\theta$ ultimately; altitude of the pyramid = r ultimately; \therefore its content = $\frac{1}{3} r \cos \theta \delta\phi \cdot r \delta\theta \cdot r$ ultimately. The required solid content is the limit of the sum of such elements, and therefore is equal to

$$\iint \frac{1}{3} r^3 \cos \theta d\phi d\theta, \text{ or } \iiint r^3 \cos \theta dr d\phi d\theta.$$

This result is the same of the last article, in which the same letters evidently signify the same quantities.

SECTION XIII.

RECTIFICATION OF CURVES AND COMPLANATION OF SURFACES.

AXIOM I. Of lines which join two assigned points, a straight line is the least.

AXIOM II. Of superficies which have an assigned plane perimeter, a plane is the least.

150. *Of all lines having the same extremities as a given curve, and met by planes which meet every point of it but cannot cut it, the curve itself is the least.* This proposition is proved by an extension of a method given in the Author's "Manual of the Differential Calculus," Art. 68.

Let AB be the assigned curve, either plane or of double curvature. Then lines joining A and B and met by planes which meet but cannot cut APB , are all of some length, but not all of the same length. There is, therefore, one at least of these lines which is the shortest possible. Let (if possible) ACB be one of these lines. Then, by hypothesis, ACB is met by the plane at any point P of APB . Two different lines cannot have common to all their points, planes which meet but cannot cut them; therefore, the plane through P may be taken to cut ACB in two points E and F . Therefore, FE ,

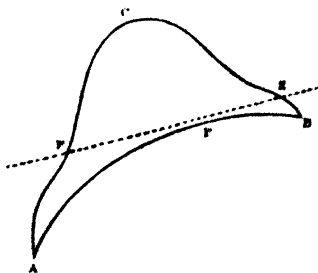

a straight line, is shorter than FCE (Axiom 1). Therefore, ACB is not the shortest of the lines in question. In the same way it may be shewn that any other line than APB is not the shortest, but a shortest exists, therefore APB is the shortest. *

151. *Of all surfaces having the same perimeter as a given surface, and met by planes which meet every point of it but cannot cut it, the given surface is the least.* Let APB be the assigned surface,

having an assigned perimeter $AaBb$. Then, surfaces having that perimeter and met by planes which meet but cannot cut APB , have all some magnitude, but not all the same magnitude. There is, therefore, one at least of these surfaces which is the least possible. Let ACB be one of these surfaces. Then, by hypothesis, ACB is met by the plane through any point P of APB .

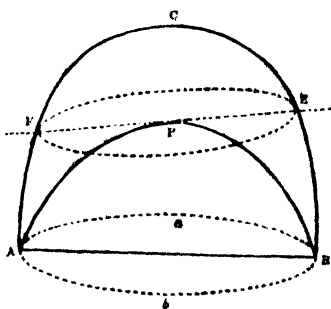

Two different surfaces cannot have common tangent planes at all their points. Therefore, the plane through P may be taken to cut ACB , which cuts off from that plane a plane superficies. This plane superficies is less (Axiom II.) than the curved surface between it and C . Therefore ACB is not the least of the surfaces in question. In the same way it may be shewn that no other surface than APB is the least. But a least surface exists. Therefore APB is the least surface.

152. *The length of a curve the limit of the length of a polygon.* Let AB be a normal to any curve, CBc (plane or of double curvature) and Cc a chord intersecting the normal perpendicularly at D . Draw cBE at right angles to AB , and in the same plane the normal ACE , and CF perpendicular to AC . ECF is a right angle; $\therefore EF > CF$.

Let the arc cBC be of such length that its curvature is continuous; then F and the curve are on opposite sides of touching planes at all points between C and B . Therefore, by the last article but one,

$$BF + CF > CB, \text{ but } EF > CF;$$

$$\therefore BE > BC.$$

Arc $CB >$ chord $CB > CD$ (*a fortiori*).

By similar triangles,

$$BE : DC :: AB : AD.$$

As the curvature is continuous, the chord Cc ultimately coincides with the tangent at B , when the arc CB is indefinitely diminished. Hence, ultimately, AD is equal to the finite line AB , which is the length of two ultimately intersecting normals, and therefore is a radius of curvature; \therefore the limit of the ratio $CD : EB$ is 1. Hence, since the arc CB is between CD and BE in magnitude, the limit of its ratio to either of them is 1,

$$\therefore \text{limit } \frac{CB}{CD} = 1; \text{ similarly, } \text{limit } \frac{cB}{cD} = 1.$$

$$\text{Adding, } \text{limit } \frac{CBc}{CDc} = 1, \text{ or } \text{limit } \frac{\text{arc}}{\text{chord}} = 1.$$

Hence it follows, that if in or about any curve of finite magnitude be described a polygon of any number of sides, the length of the curve is equal to the limit of their sum when they are indefinitely diminished in magnitude and increased in number.

COROLLARY. Let CDC be the arc of a circle of which A is the centre, and the angle $BAC = \theta = \frac{CB}{AC}$ according to

the circular measure of angles. $\frac{CD}{AC} = \sin \theta$;

$$\therefore 1 = \text{limit } \frac{CB}{CD} = \text{limit } \frac{CB}{AC} \div \frac{CD}{AC} = \text{limit } \frac{\theta}{\sin \theta}.$$

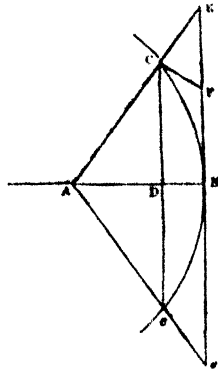

Similarly, $\lim_{\theta \rightarrow 0} \frac{\theta}{\tan \theta} = 1$.

153. *Rectification of curves.* If rectangular co-ordinates, (x, y, z) and $(x + \delta x, y + \delta y, z + \delta z)$, define two points in a curve, the distance between them is $(\delta x^2 + \delta y^2 + \delta z^2)^{\frac{1}{2}}$, which is the length of the chord. Hence the length of the curve is the limit of the sum of quantities of the form of $(\delta x^2 + \delta y^2 + \delta z^2)^{\frac{1}{2}}$.

$$= \int \left(1 + \frac{dy^2}{dx^2} + \frac{dz^2}{dx^2} \right)^{\frac{1}{2}} dx.$$

When the curve is plane one co-ordinate may be omitted, and the expression for the length of the curve becomes

$$\int \left(1 + \frac{dy^2}{dx^2} \right)^{\frac{1}{2}} dx.$$

154. *The superficies of a curved surface is the limit of the superficies of a polyhedron.* Let a polyhedron of any number of sides be circumscribed about a curved surface which is taken of such magnitude that its curvature is continuous. Then all tangent planes of the curved surface cut the polyhedron. Therefore (Art. 151), it is greater than the curved surface.

Within the curved surface inscribe a similar and similarly situated polyhedron. It is clear that planes may be drawn through every point of this polyhedron, which do not cut it, but cut the curved surface. Therefore, by the same article, this polyhedron is less than the curved surface.

Also, in a *continuous* curved surface, an inscribed plane ultimately coincides with a tangent plane when the surface subtended is indefinitely diminished. Therefore, the edges of the inscribed and circumscribed polygons ultimately coincide, and the limit of the ratio of the lengths of two homologous edges is 1 (Art. 152).

Also, their homologous sides, being in the duplicate ratio of their homologous edges, have 1 for the limit of their ratio. Therefore, the surfaces of the polyhedrons are ultimately equal. Consequently, the curved surface between them is ultimately equal to that of either polyhedron.

155. *Section of a parallelepiped.* The following proposition will be required in determining the complanation of solids.

Let $ABCD$ be the base of a rectangular parallelepiped, of which the sides AaD , aB , bC , cCD are cut by the plane $abcD$, which is a parallelogram. Its area is required.

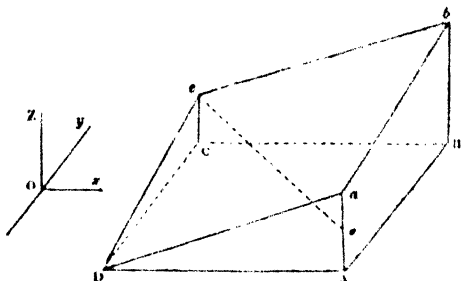

In the right-angled triangle aAD , $aD^2 = Aa^2 + AD^2$, (1.) Similarly, $Dc^2 = DC^2 + Cc^2$, (2.) To find the distance ac , let a perpendicular ce be drawn from c on to Aa . Then $ae = Aa - Cc$, and in the right-angled triangle ace ,

$$\begin{aligned} ac^2 &= ce^2 + (Aa - Cc)^2 = AC^2 + (Aa - Cc)^2 \\ &= AD^2 + CD^2 + (Aa - Cc)^2, \quad (3) \end{aligned}$$

In the triangle aDc , by a trigonometrical formula,

$$\begin{aligned} ac^2 &= aD^2 + cD^2 - 2aD \cdot cD \cos aDC; \text{ or from (1), (2), (3),} \\ AD^2 + CD^2 + (Aa - Cc)^2 &= aA^2 + AD^2 + DC^2 + Cc^2 \\ &\quad - 2(aA^2 + AD^2)^{\frac{1}{2}}(DC^2 + Cc^2)^{\frac{1}{2}} \cos aDC; \end{aligned}$$

$$\therefore Aa \cdot Cc = (aA^2 + AD^2)^{\frac{1}{2}}(DC^2 + Cc^2)^{\frac{1}{2}} \cos aDC;$$

also required area $abcD = aD \cdot cD \sin aDc$, and

$$\sin^2 aDc = 1 - \cos^2 aDc; \therefore (abcD)^2 =$$

$$\begin{aligned} &(aA^2 + AD^2)(DC^2 + Cc^2) \left\{ 1 - \frac{Aa^2 \cdot Cc^2}{(aA^2 + AD^2)(DC^2 + Cc^2)} \right\} \\ abcD &= (aA^2 \cdot DC^2 + AD^2 \cdot DC^2 + AD^2 \cdot Cc^2)^{\frac{1}{2}}. \end{aligned}$$

156. *Complanation of surfaces.* Let the surface be referred to rectangular co-ordinates x, y, z . Also, suppose the surface be cut by several planes parallel to the planes xz, yz , respectively. Then, by Art. 154, the surface is equal to the

limit of the sum of the sides of an inscribed polygon, and therefore is equal to the limit of the sum of parallelograms inscribed within the surface and bounded by the supposed planes.

In the last figure, let AD be parallel to the axis of x ; AB to that of y ; Aa to that of z ; and let (x, y, z) be the co-ordinates of D and $DA = \delta x$; $AB = \delta y$. Also let D , a , and b be three points in a curved surface. Then, if in the equation to the surface, when x is increased by δx , and y does not increase, z be increased by $\delta_x z$, $Aa = \delta_x z$. Similarly, if $\delta_y z$ be an increment of z , due to an increment δy , x not increasing, $Cc = \delta_y z$. Therefore, by the last article,

$$abcD = (\delta_x z^2 \cdot \delta y^2 + \delta x^2 \cdot \delta y^2 + \delta_y z^2 \cdot \delta x^2)^{\frac{1}{2}}.$$

Hence the required surface is equal to the limit of the sum of terms of the form

$$\left(1 + \frac{\delta_x z^2}{\delta x^2} + \frac{\delta_y z^2}{\delta y^2}\right)^{\frac{1}{2}} \delta x \delta y,$$

or the surface

$$= \iint dx dy \left\{1 + \left(\frac{dz}{dx}\right)^2 + \left(\frac{dz}{dy}\right)^2\right\}^{\frac{1}{2}},$$

where the parentheses indicate partial differential coefficients.

SECTION XIV.

INTEGRATION OF DISCONTINUOUS FUNCTIONS.

157. THE Definitions of Integrals, Arts. 17 and 115, were restricted to finite continuous functions of a finite variable, and the principles of integration were established on the tacit assumption that the integrals were finite exact quantities, and that, consequently, each function integrated had a single determinate value for each value of its independent variable.

If, therefore, a function be discontinuous, or have infinite or indeterminate values between the limits assigned for integration, or if either of these limits be infinite, the preceding definitions do not apply to it. It may be observed, that the accuracy of most of the foregoing theorems depends essentially on their application to finite functions, and is violated by the violation of this condition.

158. The following is an instance of the errors that would arise from application of the theorems of the preceding sections in neglect of the consideration of the last paragraph.

Let $y = \frac{1}{x^2}$ be the equation to a curve referred to Ox , Oy , as rectangular axes. These axes are asymptotes of the curve, which has two similar branches.

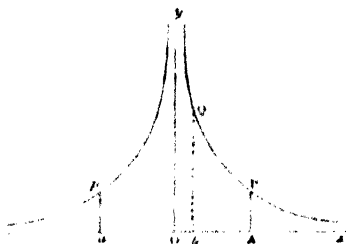

The area included by any portion of the curve, the ordinates at its extremities, and the axis of x , is equal to $\int y dx$ between corresponding limits (Art. 19), if the function integrated be finite and continuous between those limits. Therefore, the area

$$APQb = \int_b^a \frac{dx}{x^2} = \frac{1}{b} - \frac{1}{a},$$

if $OA = a$, $Ob = b$. This value of the area is increased indefinitely as b is diminished. We may, therefore, make the area $APQb$ as large as we please by taking the point b near enough to O .

If, however, we integrate from a to $-a$, we find the area

$$APypa = -\frac{2}{a},$$

if $Oa = -a$. And this result is evidently erroneous, for it gives the expression for the area, which ought to be positive (Art. 115), a negative sign, and it makes it equal to a finite quantity; whereas it has been proved, that of the area a portion may be taken indefinitely large. The error arises from integration through an infinite value of the integrated function.

159. The meaning, then, to be assigned to integrals of functions which are infinite or discontinuous between the limits of integration, is up to this place purely arbitrary; a definition of such integrals may, however, be given, which is so strictly analogous to the preceding definitions, as to render obvious the methods of extending to discontinuous functions the principles already demonstrated.

DEFINITION. If fx become infinite, impossible, or discontinuous for either or both the values $x = a$, $x = b$, but not for intermediate values, let $\int_b^a fx dx$ be defined to be

the limit of $\int_{b+\delta_2}^{a-\delta_1} fx dx$, when δ_1 and δ_2 are any continuous quantities which have the limit zero; $a - \delta_1$ and $b + \delta_2$ being values of x , between a and b .

More generally, if fx become infinite, impossible, or discontinuous for the finite number of values $a, b, c \dots m$, and for none else, of x between X and x , let, by analogy

with Art. 27, $\int_x^X fx dx$ be defined to be the limit of

$$\int_{a+\delta_1}^X fx dx + \int_{b+\delta_2}^{a-\delta_1} fx dx + \int_{c+\delta_3}^{b-\delta_2} fx dx + \dots \\ + \int_x^{m-\delta_m} fx dx \dots (a),$$

when $\delta_1, \delta'_1 \dots$ are any continuous quantities which have the limit zero; $a - \delta'_1$ and $b + \delta_2$ being between a and b , $b - \delta'_2$ and $c + \delta_3$ between b and c , &c.

160. *Principal values of integrals.* The value of $\int_x^X f x dx$, as just defined, may be dependent on the relative magnitudes of the arbitrary quantities $\delta_1, \delta'_1 \dots$. If these quantities be assumed to be all equal, the integral has then what is termed by M. Cauchy its *principal value*.

EXAMPLE.—The following is an instance of an integral, of which the value, according to the above definition, is essentially arbitrary:—

$$\begin{aligned} \int_{-a}^{+a} \frac{dx}{x} &= \text{limit} \left(\int_{\delta_1}^a \frac{dx}{x} + \int_{-a}^{-\delta_2} \frac{dx}{x} \right) \\ &= \text{limit} \left(\int_{\delta_1}^a \frac{dx}{x} + \int_a^{\delta_1} \frac{dx}{x} \right) \text{ Art. 39, IV.} \\ &= \text{limit} \log_e \frac{\delta_2}{\delta_1} = \log_e \left(\text{limit} \frac{\delta_2}{\delta_1} \right). \quad (\text{Art. 15.}) \end{aligned}$$

a quantity to which any value whatever may be assigned at pleasure, by assigning a corresponding relation between the arbitrary quantities δ_1, δ_2 .

If in the preceding result $\delta_1 = \delta_2$, we have the "principal" value of the integral equal to $\log_e 1 = 0$.

161. *Condition that integrals may be determinate.* Every function which is finite and continuous between any exact limits, either continually increases or continually decreases, or alternately increases and decreases an exact number of alternations. Take two limits, between which it continually increases or decreases. The integral of the function between those limits is (Art. 22) between its two finite quadratures, and is, therefore, a finite quantity. It is also determinate, not arbitrary, for the only arbitrary quantities in the quadratures disappear from them in the limit, Art. 26. Also, the whole integral between any finite limits is the sum of integrals, such as that just considered, and of which the

number is that of the alternations referred to. Therefore, the whole integral is an exact quantity.

If, however, the function to be integrated be not always finite and continuous between the limits of integration, the integral is the limit of the sum of the integrals of (a) in the last article but one. If the limit of all of them be finite, $\int_x^X f x dx$ (their sum) is finite. It is then also determinate. For each of the integrals of (a) is determinate according to the last paragraph, and the only arbitrary quantities δ, δ', \dots disappear in the limit.

Hence, when $\int_x^X f x dx$ is either infinite or indeterminate, the integrals in (a) have not all finite limiting values. If those which are infinite in the limit be all positive, $\int_x^X f x dx$ is evidently equal to $+\infty$; if they be all negative, to $-\infty$. Hence, the only case in which $\int_x^X f x dx$ can be indeterminate or arbitrary, is when more than one of the integrals in (a) are infinite, and have different signs in the limit, when $\int_x^X f x dx$ takes the indeterminate form (adding together the infinite quantities with like signs) $\infty - \infty$.

For instance, in the last example, $\int_{-a}^a \frac{dx}{x}$ is the limit of the sum of two integrals, of which the first has the limiting value $+\infty$, and the second $-\infty$.

162. The preceding principles may be illustrated geometrically. First, with respect to finite continuous functions: let y be such a function of x , and x, y , the co-ordinates of a plane curve which will be *unbroken*, since the function is continuous. Whatever may be the form of the curve, a finite area is included by a finite portion of the axis of x , the ordinates at the extremities of that portion, and the arc between them. But this area is equal to $\int y dx$, taken between finite limits.

Next, let the function be not always finite and continuous. Then it will be represented by a curve, $y = f x$, which has infinite branches, or breaks, or both.

Where there are breaks only, as from B to C and D to F, and not infinite branches, let a and b be the values of x at the points a and b in the diagram. Then the area $aABb$ is evidently equal

to the limit of $\int_{a+\delta_1}^{b-\delta_2} y dx$, a

finite quantity. Similarly, the areas bounded by the other parts

of the curve are expressed by the limits of integrals of the

form of those in (a), Art. 159; and the quantity $\int_x^X f x dx$

in that article represents the whole area of the curve, which is equivalent to the sum of the areas of its parts.

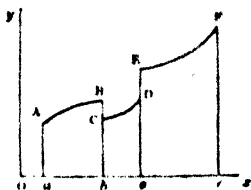

If the curve be of the form

AB, CD, and have no values of y

between Bb, Cc, the function is

impossible for the infinite number

of values of x greater than

Ob and less than Oc. Then the

definition of Art. 159, which is

restricted to functions with a finite

number of impossible values, is

inapplicable. In order to interpret

geometrically or analytically

integrals of such functions, another

definition would be required, as

essentially arbitrary as that just

mentioned.

Next, let the curve have infinite

ordinates y for finite values of x .

These ordinates are asymptotes of the

curve, and the area bounded by the

infinite branches of the curve may

be finite, as in instances given in

Arts. 126 and 127. If ordinates y

be all positive, these areas are

positive, and their sum is the quantity

$\int_x^X f x dx$, which is now

under consideration. If some of the

ordinates be negative, the corresponding

areas are negative (Art. 135), and the

limit of some of the integrals in (a),

Art. 159, will be negative; so that

$\int_x^X f x dx$, the algebraical sum of the

limits of those integrals, will represent the

difference between the total areas on

opposite sides of the axis of x .

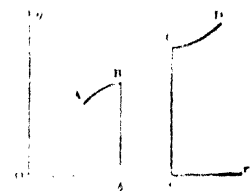

Lastly, let the curve be such as to represent $\int_x^X f x dx$

in the form $\infty - \infty$. The curve, of which the equation

is $y = \frac{1}{x}$, has two similar infinite branches; one on the positive and one on the negative sides of both axes, which are asymptotes. Let $OA = a$,

$OB = \delta_1$. The area $BbaA$

$$= \int_{\delta_1}^a \frac{dx}{x} = \log \frac{a}{\delta_1}.$$

Let $OA' = -a$,

$OB' = -\delta_2$;

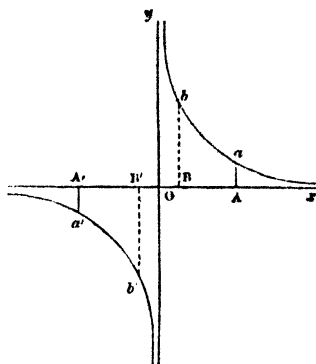

$$\text{area } B'b'a'A' = \int_{-a}^{-\delta_2} \frac{dx}{x} \text{ (Art. 135)}$$

$$= \int_a^{\delta_2} \frac{dx}{x} \text{ (Art. 39, IV.)} = \log \frac{\delta_2}{a}.$$

The integral $\int_{-a}^a \frac{dx}{x}$ is the limit of $\int_{\delta_1}^a \frac{dx}{x} + \int_{-a}^{-\delta_2} \frac{dx}{x}$

= limit of (area $BbaA - \text{area } B'b'a'A'$) as B and B' approach O . But the difference between these two is arbitrary,

or it depends on the ratio of the two arbitrary quantities OB, OB' . If we choose to assume $OB = OB'$, the two areas

$BbaA$ and $B'b'a'A'$ are always equal; their difference is then zero, which is, therefore, the "principal" value of the

integral $\int_{-a}^a \frac{dx}{x}$.

163. *Integrals with infinite limits.* The definitions of integrals (Arts. 17 and 159) were restricted to finite limits. The extension of the definition to integrals with infinite limits, may, by obvious analogy with preceding cases, be taken to be the limit which the integral with finite limits approaches when either or both limits are indefinitely increased.

164. *Multiple integrals of discontinuous functions.* Many of the principles of this section respecting integrals of one independent variable may be extended to multiple integrals.

For instance, it was shewn in Art. 118, that the result of multiple integration of finite continuous functions is the same in whatever order the several integrations be performed. This principle does not hold for functions which for particular values of the independent variables between the limits of integration become infinite.

For example, $\frac{y^2 - x^2}{(x^2 + y^2)^2}$, if x first approach the limit 0 and then y , has the limit x ; and, if y first approach the limit 0 and then x , has the limit $-x$. We cannot, therefore, affirm, that

$$\int_{-a}^a dx \int_{-b}^b dy \frac{y^2 - x^2}{(x^2 + y^2)^2}, \text{ and}$$

$$\int_{-b}^b dy \int_{-a}^a dx \frac{y^2 - x^2}{(x^2 + y^2)^2},$$

have the same result.

$$\int \frac{y^2 - x^2}{(x^2 + y^2)^2} dy = \frac{-y}{x^2 + y^2} = \frac{-2b}{x^2 + b^2},$$

taking the integral between limits, $y = b$ and $y = -b$,

$$-2b \int \frac{dx}{x^2 + b^2} = -2 \tan^{-1} \frac{x}{b} = -4 \tan^{-1} \frac{a}{b},$$

taking the integral between limits, $x = a$ and $x = -a$.

Now reverse the order of integrations.

$$\int \frac{y^2 - x^2}{x^2 + y^2} dx = \frac{x}{x^2 + y^2} = \frac{2a}{y^2 + a^2}$$

$$2a \int \frac{dy}{y^2 + a^2} = 2 \tan^{-1} \frac{y}{a} = 4 \tan^{-1} \frac{b}{a},$$

taking the integral between the same limits as before. Hence the two results differ by

$$4 \tan^{-1} \frac{a}{b} + 4 \tan^{-1} \frac{b}{a} = 4 \left(\frac{\pi}{2} - \tan^{-1} \frac{b}{a} \right) + 4 \tan^{-1} \frac{b}{a} = 2\pi.$$

165. In order that multiple integrals of discontinuous functions may be the subjects of exact investigation, a new arbitrary definition is requisite. The following is an obvious extension of the definition for discontinuous functions of one variable.

DEFINITION—Omit ranges of values of the function between arbitrary limits which include the discontinuous values. Integrate the function for the rest of its values. The limit of the result when the ranges of excluded values are as far as possible contracted is the required integral.

166. To illustrate the definition, suppose, first, that there are only two independent variables, x and y . Consider them to be rectangular co-ordinates of a point, of which $f(x, y)$, or z , is the third rectangular co-ordinate. Then $z = f(x, y)$ is the equation to a surface. Suppose, first, z to become infinite only when drawn from an isolated point (a, b) , in the plane of x, y .

Now, inclose the isolated point by any contour in that plane. Then integrate for all values of z drawn from points in the plane of x, y , without this contour. The result is, the volume of the solid under the supposed surface, *minus* the content of a tube surrounding the infinite ordinate. The analogy with the preceding definition requires that the bore of the tube be diminished indefinitely. Now, the bore or contour may diminish an infinite number of ways. Its ultimate form may be any curve or a point.

Again, all things else remaining as before, let z be infinite when drawn from any point of *some finite curve* in the plane x, y . Surround this curve by a contour on the same plane. The solid, *minus* the content of the tube, having this contour for its bore, is taken as before; but in this case the contour necessarily contracts into the assigned curve.

167. If the function include three independent variables x, y, z , we may regard $f(x, y, z)$ as some kind of magnitude (a mechanical magnitude, for instance.) which depends on

the position of points in space. Then, without assigning a meaning for the integral, we may suppose that the function becomes infinite, either at an isolated point, or at all points in a certain line, or all in a certain surface, or all in a certain solid. In either case, suppose the point or points surrounded by a surface. The required integral is the limit of that of the remaining solid when the surrounding surface is contracted to the utmost. When its ultimate form is a surface, the equation to it gives one relation between the variable limiting values of x , y , z ; when the ultimate form is a line, the equations to it give two relations; when the ultimate form is a point, three. In the same way with n independent variables, it may be conceived that 1, or 2, or 3 ... or n such relations exist, of which, some may be arbitrary.

168. The required integral, consequently, may depend on arbitrary relations, and itself, therefore, be arbitrary. Where, however, the function is such as to be infinite only for *isolated* values of the variables, and is the same in whatever manner the ranges of the excluded values are contracted, the following method gives the required determinate result.

Let a function $f(z, y, x \dots s, r)$ become infinite or discontinuous for a finite number of values of the independent variables of which those of r are $a_1, a_2, a_3, \dots a_m$, and none else between R and r . Also, let the required integral

$$\int_x^Z dz \int_y^Y dy \dots \int_r^R dr f(z, y \dots r)$$

be reduced (Art. 117) to the form $\int_r^R F(r) dr$, by the successive integration of $f(z, y \dots r)$, and other functions (which have not discontinuous or infinite values until a_1, a_2, a_3, \dots be substituted in them for r). Then the required integral may be considered to be the limit of

$$\int_{a_1+\delta_1}^R F(r) dr + \int_{a_2+\delta_2}^{a_1-\delta_1} F(r) dr + \int_{a_3+\delta_3}^{a_2-\delta_2} F(r) dr + \dots \\ + \int_r^{a_m-\delta_m} F(r) dr,$$

when $\delta_1, \delta_1' \dots$ are any continuous quantities which have the limit zero; $a_1 - \delta_1$ and $a_2 + \delta_2$ being between a_1 and a_2 , $a_2 - \delta_2'$ and $a_3 + \delta_3$ between a_2 and a_3 , &c.

169. *The integral is independent of the order of integration.* Let s designate the independent variable preceding r in the order of integration of $f(z, y \dots s, r)$, so that

$$\int_s^S f(r, s) ds = Fr,$$

just referred to. The integral is, by the preceding supposition, the limit of

$$\begin{aligned} & \int_{a_1 + \delta_1}^R dr \int_s^S f(r, s) ds + \int_{a_2 + \delta_2}^{a_1 - \delta_1'} dr \int_s^S f(r, s) ds + \dots \\ & + \int_r^{a_m - \delta_m} dr \int_s^S f(r, s) ds \dots \dots \dots (1) \end{aligned}$$

Let $b_1, b_2 \dots b_m$ be the values of s , which correspond to $a_1, a_2 \dots a_m$ of r , to render the original function discontinuous or infinite. It is required to shew that (when $\epsilon_1, \epsilon_1' \dots$ have the limit zero) the limit of

$$\begin{aligned} & \int_{b_1 + \epsilon_1}^S ds \int_r^R f(r, s) dr + \int_{b_2 + \epsilon_2}^{b_1 - \epsilon_1'} ds \int_r^R f(r, s) dr + \dots \\ & + \int_s^{b_m - \epsilon_m} ds \int_r^R f(r, s) dr \dots \dots (2) \end{aligned}$$

is the same as that of (1), if that be not arbitrary.

For brevity, omit all the symbols of integration except the limits. Then \int_s^S indicates the operation of integration of $f(r, s)$ between limits S and s . Then, since $f(r, s)$ is a continuous function, while the value of r is general,

$$\int_s^S = \int_{b_1 + \epsilon_1}^S + \int_{b_1 - \epsilon_1'}^{b_1 + \epsilon_1} + \int_{b_2 + \epsilon_2}^{b_1 - \epsilon_1'} + \int_{b_2 - \epsilon_2'}^{b_2 + \epsilon_2} + \dots + \int_s^{b_m - \epsilon_m} + \int_{b_m - \epsilon_m}^{b_m - \epsilon_m'}$$

by Art. 27. Therefore (1) becomes, supposing the operation written outside each bracket to be performed on all within it:

$$\begin{aligned}
 & \mathbf{B} \left\{ \mathbf{S} \left(b_1 + \epsilon_1 + b_1 - \epsilon'_1 + b_2 + \epsilon_2 + \dots + b_m + \epsilon_m + b_m - \epsilon'_m \right) \right. \\
 & \left. + \frac{\alpha_1 + \delta'_1}{\alpha_2 + \delta_2} \left\{ \mathbf{S} \left(b_1 + \epsilon_1 + b_1 - \epsilon'_1 + b_2 + \epsilon_2 + \dots + b_m + \epsilon_m + b_m - \epsilon'_m \right) \right\} \right. \\
 & \left. + \&c. \right.
 \end{aligned} \tag{I}$$

$$+ \frac{\alpha_m - \delta_m}{r} \left\{ \mathbf{S} \left(b_1 + \epsilon_1 + b_1 - \epsilon'_1 + b_2 + \epsilon_2 + \dots + b_m + \epsilon_m + b_m - \epsilon'_m \right) \right\}$$

In the same way (2) becomes

$$\begin{aligned}
 & \mathbf{S} \left\{ \mathbf{R} \left(\frac{\alpha_1 + \delta_1}{\alpha_1 - \delta'_1} + \frac{\alpha_1 - \delta'_1}{\alpha_2 + \delta_2} + \dots + \frac{\alpha_m + \delta_m}{\alpha_m - \delta'_m} + \frac{\alpha_m - \delta'_m}{r} \right) \right. \\
 & \left. + \frac{b_1 - \epsilon_1}{b_2 + \epsilon_2} \left\{ \mathbf{R} \left(\frac{\alpha_1 + \delta_1}{\alpha_1 - \delta'_1} + \frac{\alpha_1 - \delta'_1}{\alpha_2 + \delta_2} + \dots + \frac{\alpha_m + \delta_m}{\alpha_m - \delta'_m} + \frac{\alpha_m - \delta'_m}{r} \right) \right\} \right. \\
 & \left. + \&c. \right.
 \end{aligned} \tag{II.}$$

$$+ \frac{b_m - \epsilon'_m}{s} \left\{ \mathbf{R} \left(\frac{\alpha_1 + \delta_1}{\alpha_1 - \delta'_1} + \frac{\alpha_1 - \delta'_1}{\alpha_2 + \delta_2} + \dots + \frac{\alpha_m + \delta_m}{\alpha_m - \delta'_m} + \frac{\alpha_m - \delta'_m}{r} \right) \right\}$$

It will be found that the alternate expressions, beginning with the first and ending with the last in the $\{ \}$, correspond to integrals which are common to (I.) and (II.). Hence, the difference (I.) - (II.) does not contain those integrals.

Of all the remaining integrals, the limits written in the $\{ \}$ indefinitely approach each other when $\epsilon_1, \epsilon'_1, \dots, \delta_1, \delta'_1, \dots$ approach zero. Hence, the limit of each of these integrals is zero. Consequently, as their number is finite, the limit of the difference (I.) - (II.) is zero. Therefore, (1) and (2) have the same limit. This result shews that it is immaterial with respect to which independent variable the final integration is performed. And, with respect to all the other independent variables, the order of integration is proved to be independent in Art. 117.

SECTION XV.

DEFINITE INTEGRALS.

170. THERE are many functions, as has been already stated (Art. 40), of which the indefinite integral cannot be expressed in finite terms by ordinary algebraical, logarithmic, and circular functions; where, however, general integrals cannot be found, integrals between particular limits may be frequently determined. For instance, $\int_b^a \epsilon^{-x^2} dx$ cannot be expressed by a finite number of algebraical or trigonometrical functions of a and b ; but

$$\int_0^{\infty} \epsilon^{-x^2} dx = \frac{1}{2} \pi^{\frac{1}{2}},$$

as will be presently shewn.

The subject of definite integration is of great importance in difficult mathematical investigations, and it frequently happens that the particular limits between which definite integrals can be most readily determined, are those to which such investigations lead. The scope of this treatise will not allow of more than a very brief notice of one or two of the most important principles of definite integration.

171. *The second Eulerian integral.* $\int_0^1 \left(\log_1 \frac{1}{x} \right)^{n-1} dx$,

which is equivalent to $\int_0^{\infty} x^{n-1} \epsilon^{-x} dx$ when $\log_1 \frac{1}{x} = x$, derives its name from Euler, who first investigated it. It is designated by Legendre by the symbol $\Gamma(n)$, where n is positive. The integral is evidently a function of n only.

172. *To determine* $\int_0^{\infty} x^n \epsilon^{-ax} dx$, *where* n *is a positive integer.* In Art. 80, write $P = \epsilon^{-ax}$; $\therefore P_1 = -a^{-1} \epsilon^{-ax}$, $P_2 = a^{-2} \epsilon^{-ax}$, &c. Therefore.

$$\int x^n e^{-ax} dx = e^{-ax} (a^{-1} x^n + a^{-2} \cdot n x^{n-1} + a^{-3} \cdot n \cdot n-1 \cdot x^{n-2} + \dots + a^{-(n+1)} \cdot n \cdot n-1 \dots 2 \cdot 1).$$

When x becomes infinite, $x^n e^{-ax}$ has the limiting value zero, by evaluation according to the methods of the Differential Calculus;

$$\therefore \int_0^{\infty} x^n e^{-ax} dx = a^{-(n+1)} 1 \cdot 2 \cdot 3 \dots n. \quad \text{When } a = 1,$$

$$\int_0^{\infty} x^n e^{-x} dx = 1 \cdot 2 \cdot 3 \dots n = \Gamma(n+1)$$

by the last article; $\Gamma(2) = 1$; $\Gamma(3) = 1 \cdot 2$; $\Gamma(4) = 1 \cdot 2 \cdot 3$, &c.; $1^2 \cdot 2^2 \cdot 3^2 \dots p^2 = [\Gamma(p+1)]^2$.

173. To investigate $\int_0^{\infty} x^n e^{-ax} dx$, when n is not an integer. Changing x into ax in the equation

$$\int_0^{\infty} x^{n-1} e^{-x} dx = \Gamma(n), \quad \text{we have}$$

$$\int_0^{\infty} x^{n-1} e^{-ax} dx = \frac{\Gamma(n)}{a^n} \dots \dots (a),$$

for all positive values of n . Integrating by parts,

$$\int e^{-x} x^n dx = -e^{-x} x^n + n \int e^{-x} x^{n-1} dx.$$

Taking this between limits $x = \infty$ and $x = 0$, we have $\Gamma(n+1) = n \Gamma n$ for all finite positive values of n . Similarly, $\Gamma(n+2) = (n+1) \Gamma(n+1)$, $\Gamma(n+3) = (n+2) \Gamma(n+2)$, &c.

174. The first Eulerian integral. In (a) Art. 173, write $p+q$ for n , and $1+y$ for a . Then

$$\int_0^{\infty} x^{p+q-1} e^{-(1+y)x} dx = \frac{\Gamma(p+q)}{(1+y)^{p+q}}$$

Multiplying by $y^{q-1} dy$, and integrating between limits ∞ and 0,

$$\int_0^{\infty} \int_0^{\infty} x^{p+q-1} y^{q-1} e^{-(1+y)x} dy dx$$

$$= \Gamma(p+q) \int_0^{\infty} \frac{y^{q-1} dy}{(1+y)^{p+q}}.$$

The multiple integral may be integrated first with respect to y , considering x constant (Art. 117). The resulting integral is similar to that of (a) Art. 173. Hence, the multiple integral becomes

$$\int_0^{\infty} \frac{\Gamma q}{x^q} e^{-x} x^{p+q-1} dx = \Gamma q \int_0^{\infty} e^{-x} x^{p-1} dx = \Gamma q \cdot \Gamma p.$$

Whence from the preceding equation,

$$\frac{\Gamma p \cdot \Gamma q}{\Gamma(p+q)} = \int_0^{\infty} \frac{y^{q-1} dy}{(1+y)^{p+q}} = (p | q).$$

The integral is called the *first Eulerian integral*, and is designated by the symbol $(p | q)$, by Cournot. The preceding formula is the fundamental relation between the two Eulerian integrals. It is evident from it that

$$(p | q) = (q | p).$$

175. *Ultimate ratios of Eulerian integrals.* In the first Eulerian integral put $1+y = e^{\frac{z}{p}}$. Then, when $y=0$, $z=0$; and when $y=\infty$, $z=\infty$; so that the limits of the integral are not changed. Also, $dy = \frac{1}{p} e^{\frac{z}{p}} dz$, and the integral becomes

$$\int_0^{\infty} \frac{(\epsilon^{\frac{z}{p}} - 1)^{q-1} \epsilon^{\frac{z}{p}} dz}{p \epsilon^{\frac{z}{p}(p+q)}} = \int_0^{\infty} \frac{(\epsilon^{\frac{z}{p}} - 1)^{q-1} dz}{p \epsilon^z \epsilon^{\frac{z}{p}(q-1)}}$$

$$= p^{-q} \int_0^{\infty} \{p(1 - \epsilon^{-\frac{z}{p}})\}^{q-1} e^{-z} dz.$$

All the steps by which this result is obtained hold when p is indefinitely increased. Then the quantity in the $\{ \}$ may be put in the form $\frac{0}{0}$, and by evaluation by differentia-

tion becomes z . Hence, when p is indefinitely increased, the first Eulerian integral

$$(p | q) \text{ becomes } p^{-q} \int_0^{\infty} z^{q-1} e^{-z} dz = \frac{\Gamma q}{p^q}.$$

Therefore, substituting in the last article for $(p | q)$,

$$\frac{\Gamma p}{\Gamma(p+q)} = \frac{1}{p^q}, \quad \frac{\Gamma(p+q)}{\Gamma p} = p^q,$$

when p is indefinitely increased.

If in the last result we put for q , successively, $1+n$ and $1-n$, and multiply together the results so obtained, we have

$$\begin{aligned} 1 &= \frac{\Gamma(p+1+n) \cdot \Gamma(p+1-n)}{p^2 [\Gamma p]^2} \\ &= \frac{\Gamma(p+1+n) \cdot \Gamma(p+1-n)}{[\Gamma(p+1)]^2} \end{aligned}$$

(Art. 173), when p is indefinitely increased.

176. Multiplying together a series of the equations at the end of Art. 173, $p+1$ in number, and omitting common factors,

$$\begin{aligned} n \cdot n+1 \cdot n+2 \dots n+p &= \frac{\Gamma(n+p+1)}{\Gamma(n)}, \\ \therefore 1-n \cdot 2-n \cdot 3-n \dots p-n &= \frac{\Gamma(p+1-n)}{\Gamma(1-n)}; \end{aligned}$$

writing $1-n$ for n , and $p-1$ for p . Multiplying together these two equations, we have

$$\begin{aligned} 1^2-n^2 \cdot 2^2-n^2 \cdot 3^2-n^2 \dots p^2-n^2 &= \frac{\Gamma(p+n+1)\Gamma(p-n+1)}{n\Gamma n\Gamma(1-n)} \\ 1-\frac{n^2}{1^2} \cdot 1-\frac{n^2}{2^2} \cdot 1-\frac{n^2}{3^2} \dots 1-\frac{n^2}{p^2} &= \frac{\Gamma(p+n+1)\Gamma(p-n+1)}{1^2 \cdot 2^2 \cdot 3^2 \dots p^2} \cdot \frac{1}{n\Gamma(n)\Gamma(1-n)} \\ &= \frac{\Gamma(p+n+1) \cdot \Gamma(p-n+1)}{[\Gamma(p+1)]^2} \cdot \frac{1}{n\Gamma(n)\Gamma(1-n)}. \end{aligned}$$

By Art. 175 the first fraction on the second side of this equation converges to the value 1, as p is indefinitely increased;

$$\therefore 1 - \frac{n^2}{1^2} \cdot 1 - \frac{n^2}{2^2} \cdot 1 - \frac{n^2}{3^2} \dots \text{ad inf. } \frac{1}{n \Gamma(n) \Gamma(1-n)};$$

$$\therefore \frac{\sin n\pi}{n\pi} = \frac{1}{n \Gamma(n) \Gamma(1-n)}, \text{ or } \Gamma(n) \Gamma(1-n) = \frac{\pi}{\sin n\pi}.$$

Hence when $n = \frac{1}{2}$,

$$[\Gamma(\frac{1}{2})]^2 = \pi, \quad \Gamma(\frac{1}{2}) = \pi^{\frac{1}{2}} = \int_0^{\infty} x^{-\frac{1}{2}} e^{-x} dx.$$

$$\text{Also, writing } \frac{1}{n} \text{ for } n, \quad \Gamma\left(\frac{1}{n}\right) \Gamma\left(\frac{n-1}{n}\right) = \frac{\pi}{\sin \frac{\pi}{n}},$$

$$\frac{2}{n} \text{ for } n, \quad \Gamma\left(\frac{2}{n}\right) \Gamma\left(\frac{n-2}{n}\right) = \frac{\pi}{\sin \frac{2\pi}{n}},$$

$$\dots \dots \dots$$

$$\frac{n-1}{n} \text{ for } n, \quad \Gamma\left(\frac{n-1}{n}\right) \Gamma\left(\frac{1}{n}\right) = \frac{\pi}{\sin \frac{n-1}{n} \pi}.$$

Multiplying $(n-1)$ of these equations together, and remembering that $\sin \frac{\pi}{n} \cdot \sin \frac{2\pi}{n} \dots \sin \frac{n-1}{n} \pi = \frac{n}{2^{n-1}}$, we have

$$\left[\Gamma\left(\frac{1}{n}\right) \Gamma\left(\frac{2}{n}\right) \dots \Gamma\left(\frac{n-1}{n}\right) \right]^2 = \frac{\pi^{n-1} \cdot 2^{n-1}}{n}.$$

From $\int_0^{\infty} x^{-1} e^{-x} dx = \pi^{\frac{1}{2}}$, we easily find

$$\int_0^{\infty} e^{-x^2} dx = \frac{1}{2} \pi^{\frac{1}{2}}, \text{ putting } x^2 = x.$$

177. To investigate $\int_0^{\infty} dx e^{-ax} \cos rx$. Integrating by parts,

$$\int dx e^{-ax} \cos rx = -\frac{1}{a} e^{-ax} \cos rx - \frac{r}{a} \int e^{-ax} \sin rx dx$$

$$\int dx e^{-ax} \sin rx = -\frac{1}{a} e^{-ax} \sin rx + \frac{r}{a} \int e^{-ax} \cos rx dx;$$

$$\therefore \int dx e^{-ax} \cos rx = -e^{-ax} \frac{a \cos rx - r \sin rx}{a^2 + r^2}$$

$$\int dx e^{-ax} \sin rx = -e^{-ax} \frac{a \sin rx + r \cos rx}{a^2 + r^2}.$$

These integrals are to be taken between limits $x = \infty$ and $x = 0$. When a is positive and not zero, e^{-ax} is zero at the former limit, at which also the fractions on the second sides of these equations are finite if a and r be not zero, since sines and cosines are finite by their definition. Again, when x has the limit 0, $e^{-ax} = 1$ if a be finite; the numerators of the fractions become a and r respectively, if a and r be finite. Hence

$$\int_0^{\infty} dx e^{-ax} \cos rx = \frac{a}{a^2 + r^2};$$

$$\int_0^{\infty} dx e^{-ax} \sin rx = \frac{r}{a^2 + r^2} \dots\dots (1.)$$

178. *Sine and cosine of an infinite angle.* If, in defiance of the restrictions with respect to a and r , by which these results are obtained, we put $a = 0$, r remaining finite, and assume that $e^{-ax} = 1$, for all values of x between its limits, the results apparently become

$$\int_0^{\infty} dx \cos rx = 0; \quad \int_0^{\infty} dx \sin rx = \frac{1}{r} \dots\dots (2.)$$

whence, since

$$\int dx \cos rx = \frac{\sin rx}{r}, \quad \int dx \sin rx = -\frac{\cos rx}{r},$$

it would follow that $\cos \infty = 0$ and $\sin \infty = 0$.

But it is essential to the evaluation of the original definite integral that $ax = \infty$, when $x = \infty$; a condition which re-

quires an arbitrary relation between x and a if the latter have the limit 0. Moreover, the supposed values of $\cos \infty$ and $\sin \infty$ violate the relation $\sin^2 + \cos^2 = 1$, which is part of the very definition of "sine" and "cosine."

The antecedent objection to assigning a definite value to the sine or cosine of an infinite angle is perfectly insuperable; for, however great a number of times the radius describing the angle revolve, the sine and cosine will vary from 1 to -1 in the course of *each* revolution.

The correct statement to be substituted for equations (2) appears to be, that the original definite integrals of $\epsilon^{-ax} \cos rx$ and $\epsilon^{-ax} \sin rx$, approach the limits 0 and $\frac{1}{r}$ respectively, when a approaches the limit 0, r remaining finite.

Since equations (1) are true for all finite positive values of a and r , let $r^2 = na$ where n is any arbitrary number. Then, the first equation of (1) becomes

$$\int_0^{\infty} dx \epsilon^{-ax} \cos (na)^{\frac{1}{2}} x = \frac{1}{a + n}$$

If it were allowable to put $a = 0$, we should have in strict analogy with (2), $\int_0^{\infty} dx = \frac{1}{n} \therefore \infty = \frac{1}{n}$, any finite arbitrary quantity, — a result which obviously contradicts the fundamental principles of the Integral Calculus.

170. To investigate $\int_0^{\infty} dx \epsilon^{-ax} \cos^2 x$, By integration by parts twice, it is easily found that

$$\int dx \epsilon^{-ax} \cos^2 x = \epsilon^{-ax} \cos x \frac{2 \sin x - a \cos x}{a^2 + 4} - \frac{2 \epsilon^{-ax}}{a(a^2 + 4)}$$

When $x = \infty$, ϵ^{-ax} is zero for all positive values of a not zero, and therefore the second side of the preceding equation vanishes. When $x = 0$, the same side becomes

$$-\frac{a}{a^2 + 4} - \frac{2}{a(a^2 + 4)};$$

$$\therefore \int_0^{\infty} \epsilon^{-ax} \cos^2 x dx = \frac{a^2 + 2}{a(a^2 + 4)}$$

180. *Differentiation of definite integrals.* The differential coefficient with respect to c of a definite integral

$$\int_b^a f(x, c) dx,$$

is found by differentiating under the \int the function $f(x, c)$. Let F be the integral, and δF its increment, due to an increment δc of c ; and let $\delta f(x, c)$ be the corresponding increment of $f(x, c)$.

$$\begin{aligned} \delta f &= \int_b^a f(x, c + \delta c) dx - \int_b^a f(x, c) dx \\ &= \int_b^a \{f(x, c + \delta c) - f(x, c)\} dx, \end{aligned}$$

$$\frac{\delta f}{\delta c} = \int_b^a \frac{\delta f(x, c)}{\delta c} dx, \text{ and } \frac{df}{dc} = \int_b^a \frac{df(x, c)}{dc} dx,$$

when δc has the limit zero.

181. To investigate $\int_0^\infty dx e^{-ax^2} \cos 2cx$. The principle of the last article is remarkably illustrated by this integral. Calling it F ,

$$\frac{dF}{dc} = - \int_0^\infty dx 2x e^{-ax^2} \sin 2cx \dots (1)$$

$$= \int_0^\infty \left(a^{-\frac{1}{2}} \cdot e^{-ax^2} \sin 2cx \right) - 2ca^{-\frac{1}{2}} \int_0^\infty dx e^{-ax^2} \cos 2cx,$$

integrating by parts. The quantity in the bracket disappears when taken between the assigned limits, for all finite values of c , a not being zero;

$$\therefore \frac{dF}{dc} = -2ca^{-\frac{1}{2}} F; \quad \therefore \frac{dF}{F} = -2ca^{-\frac{1}{2}} dc.$$

Integrating, $\log F = -c^2 a^{-\frac{1}{2}} + \text{a constant}$, or $F = C e^{-c^2 a^{-\frac{1}{2}}}$. Equation (1) and all that follow from it are true for all finite values of c , positive or negative. Therefore, if in the last equation, c having the limiting value 0, we have

$$C = \int_0^{\infty} dx e^{-a^2 x^2} = \frac{1}{2a} \int_0^{\infty} z^{-\frac{1}{2}} e^{-z} dz,$$

putting $a^2 x^2 = z$. Hence, by Art. 176, $C = \frac{\pi^{\frac{1}{2}}}{2a}$;

$$\therefore \int_0^{\infty} dx e^{-a^2 x^2} \cos 2cx = \frac{\pi^{\frac{1}{2}}}{2a} e^{-c^2 a^{-2}}.$$

This integral is due to Laplace:—*Mémoires de l'Institut*, 1810.

APPENDIX.

DEMONSTRATION OF TAYLOR'S THEOREM.

LET any function (f) of a single variable and its successive differential coefficients (f' , f'' , &c.) be finite and continuous for all values of the variable from a to $a + h$. In the expression

$$f(a+x) - f(a) - f'(a)x - f''(a)\frac{x^2}{1.2} - \dots - f^{(n-1)}(a)\frac{x^{n-1}}{1.2\dots n-1} - R\frac{x^n}{1.2\dots n} \quad (1),$$

let R be such a finite quantity, not involving x , that when $x = h$ the expression = 0. It is also zero when $x = 0$. But a function which is zero for two different values of its variable cannot be always increasing nor always decreasing in the interval. Hence there is some value (x_1) of x between 0 and h , for which the differential coefficient of (1) (i. e. its rate of increase) is zero; or,

$$f'(a+x) - f'(a) - f''(a)x - f'''(a)\frac{x^2}{1.2} \dots - R\frac{x^{n-1}}{1.2\dots n-1} \dots \quad (2),$$

is zero when $x = x_1$; (2) is zero also when $x = 0$. Therefore, as before, there is a value of x between x_1 and 0, for which the differential coefficient of (2) is zero. Continuing the process to n differentiations, we have, finally, $f^{(n)}(a+x) - R = 0$, when x has some value between 0 and h . Let this value be θh where θ is a proper fraction. Then $R = f^{(n)}(a + \theta h)$. Substituting this value of R in (1), and putting (1) = 0 when $x = h$,

$$f(a+h) = f(a) + f'(a)h + f''(a)\frac{h^2}{1.2} + \dots + f^{(n)}(a + \theta h)\frac{h^n}{1.2\dots n},$$

which is Lagrange's Theorem on the Limits of Taylor's Theorem.

If the last term of this series become zero when n is sufficiently large,

$$f(a+h) = fa + f'a \cdot h + f''a \cdot \frac{h^2}{1 \cdot 2} + \dots \text{ to convergence,}$$

which is Taylor's Theorem.

This demonstration is a somewhat simplified form of one originally published by the Author, in the "Cambridge and Dublin Mathematical Journal," vol. vi., p. 80, and reprinted in his "Manual of the Differential Calculus," Art. 54.

2. TAYLOR'S THEOREM DEMONSTRATED BY INTEGRATION.

By successive integration by parts,

$$\begin{aligned} \int f'(a+h-z) dz &= z f'(a+h-z) + \int z f''(a+h-z) dz \\ &= z f'(a+h-z) + \frac{z^2}{1 \cdot 2} f''(a+h-z) + \int \frac{z^2}{1 \cdot 2} f'''(a+h-z) dz \\ &= \&c. \\ &= z f'(a+h-z) + \frac{z^2}{1 \cdot 2} f''(a+h-z) + \frac{z^3}{1 \cdot 2 \cdot 3} f'''(a+h-z) + \dots \\ &\quad + \int \frac{z^{n-1}}{1 \cdot 2 \dots n-1} f^n(a+h-z) dz. \end{aligned}$$

Take this result between $z=k$ and $z=0$. The first side of the equation becomes, by Art. 30, (III.), $f(a+h) - fa$. Then, transferring fa to the second side of the equation taken between limits,

$$\begin{aligned} f(a+h) &= fa + f'a \cdot h + f''a \cdot \frac{h^2}{1 \cdot 2} + \dots \\ &\quad + \int_0^h \frac{z^{n-1}}{1 \cdot 2 \dots n-1} f^n(a+h-z) dz, \end{aligned}$$

which expresses the remainder of Taylor's series by a definite integral.

