









THE JOURNAL  
OF  
EXPERIMENTAL ZOÖLOGY

EDITED BY

WILLIAM K. BROOKS  
*Johns Hopkins University*

WILLIAM E. CASTLE  
*Harvard University*

EDWIN G. CONKLIN  
*University of Pennsylvania*

CHARLES B. DAVENPORT  
*Carnegie Institution*

HERBERT S. JENNINGS  
*University of Pennsylvania*

FRANK R. LILLIE  
*University of Chicago*

JACQUES LOEB  
*University of California*

THOMAS H. MORGAN  
*Columbia University*

GEORGE H. PARKER  
*Harvard University*

CHARLES O. WHITMAN  
*University of Chicago*

EDMUND B. WILSON, *Columbia University*

AND

ROSS G. HARRISON  
*Johns Hopkins University*  
MANAGING EDITOR

VOLUME II

THE JOURNAL OF EXPERIMENTAL ZOÖLOGY  
BALTIMORE

1905

418



# CONTENTS.

No. 1.—April, 1905.

CHARLES ZELENY, Compensatory Regulation. With 29 figures.....	1
AMOS W. PETERS, Phosphorescence in Ctenophores.....	103
ISABEL McCRACKEN, A Study of the Inheritance of Dichromatism in <i>Lina Lapponica</i> . With 1 plate and 3 figures in the text.....	117
C. B. DAVENPORT, Evolution without Mutation.....	137

No. 2.—May, 1905.

✓ EDWIN G. CONKLIN, Mosaic Development in Ascidian Eggs. With 82 figures.....	145
C. W. HAHN, Dimorphism and Regeneration in <i>Metridium</i> . With 2 figures.....	225
CHARLES G. ROGERS, The Effect of Various Salts upon the Survival of the Invertebrate Heart. With 1 plate.....	237
C. M. CHILD, Studies on Regulation. VII. Further Experiments on Form Regulation in <i>Leptoplana</i> . With 34 figures.....	253
✓ NAOHIDÉ YATSU, The Formation of Centrosomes in Enucleated Egg-Fragments. With 8 figures.....	287

N. M. STEVENS, A Study of the Germ Cells of <i>Aphis Rosæ</i> and <i>Aphis Enotheræ</i> . With 4 plates .....	313
N. M. STEVENS AND A. M. BORING, Regeneration in <i>Polychœrus Caudatus</i> . Part I. Observations on Living Material. By N. M. Stevens. With 21 figures.....	335
Part II. Histology. By A. M. Boring. With 2 plates and 1 figure in the text .....	340
CHARLES ZELENY, The Relation of the Degree of Injury to the Rate of Regeneration. With 6 figures.....	347
EDMUND B. WILSON, Studies on Chromosomes. I. The Behavior of the Idiochromosomes in Hemiptera. With 7 figures.....	371
G. H. PARKER, The Movements of the Swimming Plates in Ctenophores, with Reference to the Theories of Ciliary Metachronism. With 2 figures.....	407
HENRY EDWARD CRAMPTON, On a General Theory of Adaptation and Selection.....	425
WARREN HARMON LEWIS, Experimental Studies on the Development of the Eye in Amphibia. II. On the Cornea. With 2 plates.....	431

H. S. JENNINGS, Modifiability in Behavior. I. Behavior of Sea Anemones.....	447
H. S. JENNINGS, The Method of Regulation in Behavior and in Other Fields.....	473
T. H. MORGAN, "Polarity" Considered as a Phenomenon of Gradation of Materials.....	495
EDMUND B. WILSON, Studies on Chromosomes. II. The Paired Microchromosomes, Idiochromo- somes and Heterotropic Chromosomes in Hemiptera.....	507
CHAS. W. HARGITT, Variations Among <i>Seyphomedusæ</i> . With 1 plate and 17 figures in the text .....	547
LORANDE LOSS WOODRUFF, An Experimental Study on the Life-History of Hypotrichous Infusoria. With 3 plates and 12 figures in the text.....	585



576

# COMPENSATORY REGULATION.

BY

CHARLES ZELENY.

General Introduction.....	2
Data.....	5
I. The Leaflets of the Compound Leaf.....	5
II. The Rate of Regeneration of the Arms in the Brittle-star, <i>Ophioglypha lacertosa</i> ....	7
1. Introduction.....	7
2. Method.....	8
3. Data.....	14
4. Discussion.....	16
III. The Opercula of Serpulids.....	18
1. Comparative Anatomy.....	19
1. The genus <i>Hydroides</i> .....	19
2. Other genera of Serpulids.....	24
3. Distribution of the Opercula between Right and Left Sides.....	32
4. Exceptional Degrees of Development and One Case of a Supernumerary Operculum.....	37
2. Development of Opercula—	
1. Ontogenetic Development.....	38
a. Introduction.....	38
b. Historical Review.....	39
c. Observations.....	41
d. Summary of Data and Discussion.....	51
2. Regeneratory Development.....	54
a. Introduction.....	54
b. Unoperated Condition of the Opercula in <i>H. dianthus</i> .....	55
c. Operations on Functional Operculum.....	55
d. Operations on Rudimentary Operculum.....	58
e. Operations on Both Opercula.....	59
f. Body Cut in Two.....	62
g. Progressive Changes in Opercula.....	65
h. Experiments on Group V.....	65
i. Experiments on Group IV.....	67
j. Experiments on Group VI.....	69
k. Discussion of the Data.....	71
3. Probable Phylogenetic Development.....	72
3. Comparison of Regeneratory, Ontogenetic and Probable Phylogenetic Development.....	74
4. General Discussion of the Facts of Compensatory Regulation in the Opercula of Serpulids.....	76

IV. The Rate of Differentiation during Regeneration of the Opercula in the Serpulid, Apomatus.....	77
V Regulation of the Rate of Growth and Nature of Differentiation during Regeneration of the Chelæ of <i>Gelasimus</i> and <i>Alpheus</i> .....	81
1. Introduction.....	81
2. <i>Gelasimus pugilator</i> .....	81
3. <i>Alpheus dentipes</i> .....	85
General Discussion.....	96

### GENERAL INTRODUCTION.

That the development of an organ is dependent both quantitatively and qualitatively not only upon the factors inherent in its basis but also upon influences exerted by other parts of the body, is a fact that has been especially emphasized by much of the recent work in experimental embryology. The relative proportion of the two influences varies in individual cases and its determination has served as the objective point in various experimental studies. The most valuable method in attacking these problems has undoubtedly been the one in which the regulation following mutilation of the organism or change in its environment has been observed. Assuming an interaction between the parts of an organism, which is a necessary accompaniment of the idea of their correlation, we must consider the animal or plant as a system in equilibrium very nearly stable at certain periods, as in adults, and with a unilateral instability at other periods, as in embryonic development. This statement must apply not only to the organism as a whole but to all its parts and groups of parts individually.

A disturbance of the normal relations of the parts, such as is brought about by the removal of one of them or by the changing of the external environment, must lead to changes which if the system is not too rigid can give important light upon the normal relations of the parts. This is the fundamental consideration which lies at the base of all experimental biology and in the broad sense of the term all such studies are studies in compensatory regulation.

Of special importance in the present consideration is the fact that while the parts of an organism and their interactions are continually undergoing change, especially during the period of unilateral instability, the so-called embryonic period, these changes are of a remarkably constant character for individuals

of a species, notwithstanding environmental changes within a fairly wide limit. At the same time members of different species are constantly dissimilar notwithstanding similar external environments in many cases.

Disturbances of the system of an organism as above conceived may be conveniently grouped under two heads: First, disturbances in external environment, not considered here, and second, direct internal disturbances. As direct internal disturbances may be classed all mutilations. The removal of a part causes disturbances in the remaining parts which as the result of a new mode of interaction adjust themselves to a new stable system. As an example may be mentioned the rearrangement of the leaflets of a compound palmate leaf after removal of one of them. When complete regeneration takes place the new system may finally regain its original condition. However, during the intermediate stages while the regeneration of the organ is in progress a new condition of interaction must be present and this may lead to changes both in the old parts and in the new regenerating ones, so that the new stable equilibrium is very different from the old.

In a paper on the dimensional relations of the members of compound leaves, the writer has described the changes taking place in the members of a compound leaf after removal of one of the leaflets at an early stage. In this case there was no regeneration and the effects of the operation were confined to position and length changes in the remaining members. The results of these experiments will be considered briefly in a separate section at the beginning of the following discussion.

The present paper will deal, except for the above mentioned experiments, with cases among animals where, as a result of the operation, the character of regeneration of an organ varies with the character of the remainder of the system as in the arms of *Ophioglypha* and the opercula of *Apomatus*, or where there is an evident change not only in the regenerating part but also in other parts of the system, so that the final state of equilibrium differs from the original condition, as in the opercula of *Serpulids* and the chelæ of *Alpheus*. The experiments on *Ophioglypha* have already been described in a preliminary paper (Zeleny, '03a), and likewise some of the experiments on the *Serpulid*, *Hydroides dianthus* (Zeleny, '02).

It is the plan of the present paper to take up the different groups of experiments on compensatory regulation in turn and to connect them by a final general discussion. The individual groups of experiments are thus quite independent in the descriptive portion.

The work was carried on at the Woods Hole Biological Laboratory in the summer of 1901, at the Cold Spring Harbor Laboratory in 1902, and at the Naples Zoölogical Station from September, 1902, to June, 1903. I wish to express my great obligation to Prof. C. B. Davenport, to Prof. E. B. Wilson and to Prof. T. H. Morgan, for inspiration and aid in carrying out the work, and to the members of the staffs at the three laboratories where it was done, for their uniform kindness in giving every convenience in the course of the investigation.

The data will be considered in five sections as follows:

I. In the *first* section (p. 5) the experiments on the leaflets of the compound leaf will be briefly referred to as constituting a case of regulation of a system in which there is no regeneration of the removed part. The readjustment is here confined to the uninjured portions and the assumption of an interaction between the members of the leaf constitutes an important factor in the explanation of the changes that take place.

II. In the *second* section (p. 7) the rate of regeneration of the arms of the brittle-star, *Ophioglypha*, is taken up and studied with special reference to the influence which parts of the animal away from the injured surface have upon the nature of the regeneration at that surface.

III. The *third* section (p. 18) consists of experiments on the opercula of the Serpulids made with a view to the analysis of the factors involved in the control of the asymmetry of these animals. Observations on the comparative anatomy of the opercula and on their ontogenetic development made with special reference to the problem of compensatory regulation are included.

IV. The *fourth* section (p. 77) contains observations on the regulation of the rate of differentiation in the regeneration of the opercula of the Serpulid, *Apomatus ampullifera*. The influence of the removal of the posterior part of the body upon the opercula is taken up. The experiments are put into a section separate from the main one on the opercula of Serpulids because they are not directly concerned with the interaction of the two lateral sides of

the body, *i. e.*, with the factors controlling the asymmetry of the opercula, but rather with the influence of the presence or absence of the posterior regions of the body upon the process as a whole.

V. The *fifth* section (p. 81) gives an account of experiments on the regeneration of the chelæ of the Decapod Crustaceans, *Gelasimus* and *Alpheus*, with reference, *first*, to the problem of control of the asymmetry of the chelæ in the male *Gelasimus* and in the male and female *Alpheus*; *second*, with reference to the general problem of the influence of parts away from an injured surface upon the character of the regeneration at that surface; and, *third*, with reference to the influence of the character of the operation upon the moult period.

Finally, all the data are brought together in a general discussion of the facts of compensatory regulation and their relation to the point of view which considers the organism as a system of mutually interacting parts (p. 96).

## DATA.

### I. THE LEAFLETS OF THE COMPOUND LEAF.

The simplest instance of the application of the method employed in the present paper is furnished by the experiments on the compound leaf of the palmate type, as described in my paper on "The Dimensional Relations of the Members of Compound Leaves." It will not be necessary to go into the details of that paper but a sample result may be of value, because the case there described is a pure instance of change in the uninjured organs without regeneration of the injured one. The main point of the experiments may be briefly illustrated by the following quotation from the introduction as given there:

The individual members of the compound leaf as well as of other parts of the plant respond to stimuli in a definite way. Each member is, however, limited in its reaction by its mechanical and organic relations to the other parts of the leaf. This limitation is mutual and as a result of it we get an equilibrium of forces which results in a configuration more or less definite for each species. As a further consequence each member must respond not as a unit but as part of a system. If now we have a system of this kind with a definite configuration due to the mutual interaction of its members and we remove one of the component parts, we must get a disturbance of the equilibrium leading to changes in the relations of the remaining

parts limited only by the extent to which the rigidity of the skeletal structures may counteract such a tendency. We may in this manner get at the forces which are active in correlation at the time of and subsequent to the operation. The main difficulty with the method must consist in the reaction to the stimulus of the injury itself, a factor which does not enter into the normal relations of the parts.

A sample result will illustrate the method in a more concrete manner. When an asymmetrically placed leaflet of a five-leaved form (white lupine or Virginia Creeper) is removed at the earliest possible stage, the remaining four leaflets take up positions

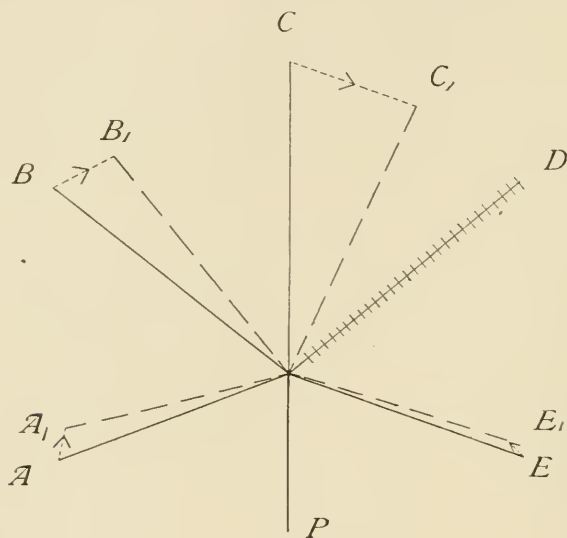

FIG. 1.

Virginia Creeper, *Parthenocissus quinquefolia*. Diagram of changes in position and length of leaflets of compound leaf after removal of one of their number ( $\times \frac{1}{2}$ ). Unbroken lines—Original positions. Dotted lines—Resultant positions. Barred lines—Removed leaflet. P—Petiole. Arrow—Direction of movement. A, B, C, D, E—Original positions. A<sub>1</sub>, B<sub>1</sub>, C<sub>1</sub>, E<sub>1</sub>—Resultant positions.

which tend to approach those of the units of a symmetrical *four*-leaved system, the chief change of position being confined to the two leaflets which were asymmetrically placed after the operation. In the case of the Virginia Creeper the resultant change of position was  $+5^{\circ}.9$  for leaflet A,  $+12^{\circ}.2$  for leaflet B,  $+24^{\circ}.4$  for leaflet C, and  $-3^{\circ}.2$  for leaflet E. (See Fig. 1.) Likewise in a three-leaved system (the red clover) after removal of an asym-

metrically placed leaflet the resulting two-leaved system tends to be symmetrical with respect to the petiole. This shows very definitely that the normal symmetrical palmate leaf has a definite configuration as a result of the interaction of its units and that the manner of this interaction may be revealed by the removal of a unit, an operation which brings about a *new* mode of interaction leading to a *new* resultant state of equilibrium.

Likewise after such an operation, which is performed at an early stage before the leaflets have fully unfolded, the remaining leaflets do not attain their full normal size, the average decrease for the leaflets of the three species being 6.8 per cent of the normal length. These changes in position and length for the Virginia Creeper are shown in the accompanying figure. (Fig. 1.)

In the following sections the experiments have to deal with more complicated cases because there is a regeneration of a new organ or organs in place of the old, and the changes in the system are the result not only of the interactions of the uninjured parts but also of these upon the regenerating part and in turn of the latter upon the former.

## II. THE RATE OF REGENERATION OF THE ARMS IN THE BRITTLE-STAR, OPHIOGLYPHA LACERTOSA.<sup>1</sup>

### I. Introduction.

*In this section we have a case of evident influence of organs situated away from a regenerating surface upon the character of the regeneration at that surface.* The influences exerted by the regenerating organ or organs upon the character of the uninjured organs, or the changes produced among the uninjured organs themselves by the new interactions resulting from the new conditions, were not studied because the material was evidently unsuitable for that purpose. The experiments to be described are, therefore, concerned entirely with the rate of regeneration of the arms as influenced by the number of arms removed. Incidentally the variation of the rate of regeneration of the arms with the size (*i. e.*, age [?]) of the animal must be considered.

<sup>1</sup>The principal results of this section were given in a preliminary paper already mentioned. (Zeleny, '03b.)

The experiments were performed at the Naples Zoölogical Station during the winter of 1902-03. The common five-armed brittle-star, *Ophioglypha lacertosa*, was used and five series of experiments, with one, two, three, four and five arms removed, respectively, were kept for 46 days after the operation and no food was supplied to them during the whole period.

The resulting data show that *the rate of regeneration of the arms varies on the one hand with the size of the animal and on the other with the number of removed arms*. Medium-sized individuals show the maximum rate of regeneration and there is a pronounced decrease both for smaller and for larger ones. The second correlation and the one that concerns us especially in the present paper gives *an increase in the rate of regeneration of an arm as we pass from the cases with a smaller to those with a greater number of removed arms*. The series with all five arms missing is excepted in the statement because the animals in this lot in every instance died or showed evidences of decay before the completion of the experiment.

## 2. Method.

Forty-five perfect specimens were divided into five equal groups of nine each, care being taken to distribute them in such a way as to make the sets approximately equivalent as regards size of individuals. The operations consisted in the removal of one or more arms by a transverse cut at the disk level. In the first series one arm was removed, in the second two contiguous arms, in the third three contiguous arms, in the fourth four, and in the fifth five arms. The animals were kept in ten "battery" jars, two for each series and *were not fed during the whole period of the experiment*. Measurements of the lengths of the regenerating arms were taken 22, 33 and 46 days after the operation. As stated above, the specimens of the series where all five arms were removed did not retain their vitality for a sufficient length of time to allow of complete comparison with the others, and they will therefore not be included in the main comparison, though the data concerning them are given in Table I.

The results are given in the accompanying table (Table I), which shows for each of the five series the disk diameters of the specimens and the lengths of the regenerating arm or arms 22, 33 and 46 days after the operation. Where more than one arm



TABLE I.

SERIES I—One Arm Cut Off.						SERIES II—Two Arms Cut Off.					
Specimen No.	Disk Diam.	22 days	33 days	46 days	Remarks	Specimen No.	Disk Diam.	22 days	33 days	46 days	Remarks
1	4.8	.15	.2	.0		1	6.0	—	—	—	dead (22)
2	6.5	.45	.1	.0		2	6.5	.55	.45	.0	
3	6.6	1.4	2.4	3.0		3	8.7	1.9	1.9	2.0	
4	11.0	.6	2.0	2.0		4	10.8	1.8	1.6	.65	
5	11.2	2.0	3.0	4.0		5	13.0	—	—	—	dead (22)
6	13.2	.2	2.0	3.1		6	13.5	1.25	2.3	3.5	
7	13.5	—	—	—	dead (22)	7	14.0	1.8	3.0	3.3	
8	14.5	1.0	—	—	dead (33)	8	15.0	.85	2.6	4.05	
9	19.8	.0	.0	.0		9	19.3	.0	.0	.0	

SERIES III—Three Arms Cut Off.						SERIES IV—Four Arms Cut Off.					
Specimen No.	Disk Diam.	22 days	33 days	46 days	Remarks	Specimen No.	Disk Diam.	22 days	33 days	46 days	Remarks
1	5.5	—	—	—	dead (22)	1	4.9	.65	1.0	.45	
2	6.5	.6	1.05	—	dead (46)	2	6.0	1.0	1.65	1.9	
3	9.0	—	—	—	dead (22)	3	8.2	2.45	4.6	6.2	
4	11.0	1.15	1.75	3.05		4	11.3	1.85	3.65	5.3	
5	12.5	1.35	2.35	3.2		5	12.3	2.15	4.3	7.1	
6	12.5	2.25	4.25	6.65		6	12.8	.6	2.1	4.05	
7	13.8	1.1	3.4	4.9		7	12.8	1.55	2.9	4.85	
8	14.3	1.1	1.7	2.15		8	15.2	1.75	3.3	5.55	
9	20.0	.05	.35	1.0		9	18.3	1.0	1.75	3.65	

SERIES V—Five Arms Cut Off.					
Specimen No.	Disk Diam.	22 days	33 days	46 days	Remarks
1	6.0	.6	.1	.0	dying (46)
2	6.5	.76	.1	.0	dying (46)
3	7.0	.6	.46	.0	dying (46)
4	11.0	2.26	2.86	2.66	
5 to 9	—	—	—	—	dead (22)

## EXPLANATION OF TABLE I.

The data for the experiments on the regeneration of the arms in *Ophioglypha lacertosa* after their removal by a cut level with the circumference of the disk. The measurements are in millimeters. In each of the sub-tables the second column gives the disk diameters, the third column the average lengths of the regenerating arms 22 days after the operation, the fourth column the lengths after 33 days and the fifth column after 46 days. In the four last tables (*i. e.*, in all except Series I) the lengths as given are the averages of all the regenerating arms of the individuals. The numbers under "Remarks" represent the time of death (in days) of specimens which did not outlive the experiment.

was removed, *i. e.*, in all except the first series, this length represents the average length of all the regenerating arms of the individual. In some specimens there is a decrease in the length of the regenerated arm from one period to another. This is due to a gradual disintegration and breaking off of the regenerating arm,

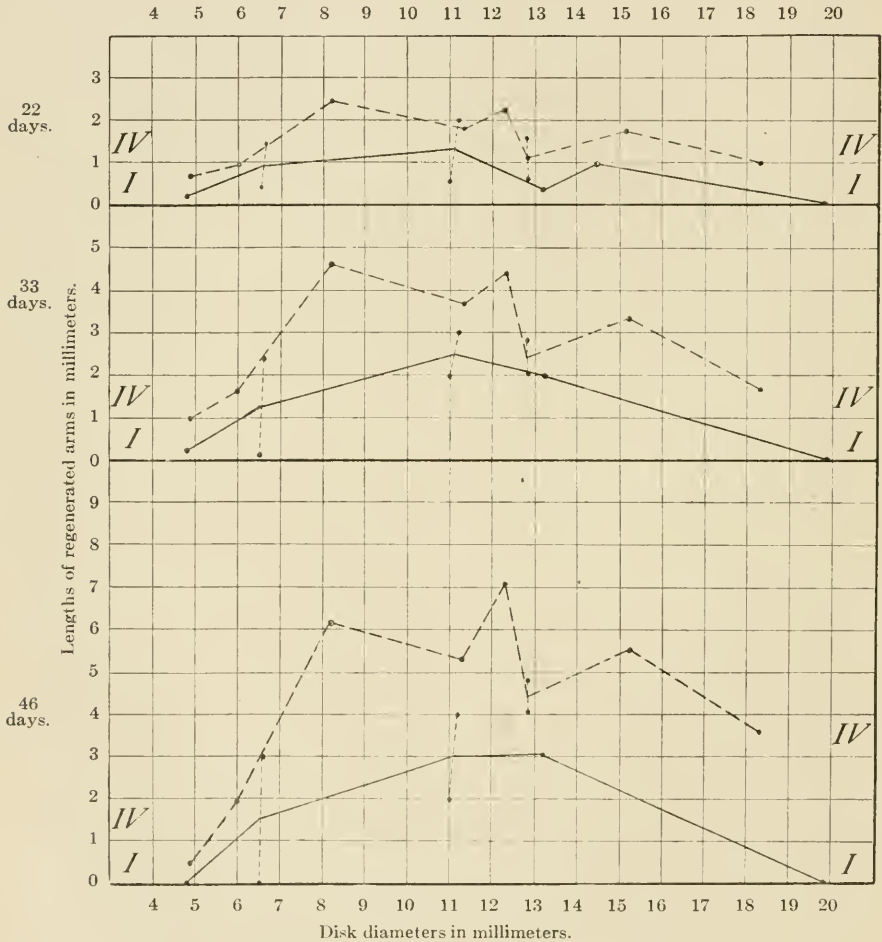

FIG. 2.

Brittle-star, *Ophioglypha lacertosa*. Comparison of lengths of regenerated arms in Series IV (four arms removed), dotted lines, with Series I (one arm removed), unbroken lines. Upper curves, 22 days; middle curves, 33 days; and lower curves, 46 days after operation. The lengths of the regenerated arms are distinctly greater in Series IV than in Series I.

a process which begins at the distal end and is usually accompanied by a loss of vitality with the approach of general bodily decay. In Series V, where all five arms were removed, none of the specimens retained its full vitality for the whole 46 days, though one did so for 33 days.

A glance at the table (Table I) is sufficient to show both of the main points brought out in the general statement of the results. In the first place the rate of regeneration of the arms is greatest in medium-sized individuals, decreasing for both the smaller and the larger ones and second, the rate of regeneration is dependent on the number of arms removed. Excepting Series V, where all the arms are removed, there is an evident increase in the rate of regeneration of the arms as we pass from the cases with the fewer to the cases with the greater number of removed arms.

As both these factors enter into the individual measurements the proper relations can best be represented graphically by means of "curves." Such "curves" are shown in Figs. 2 and 3 and the relative rates of regeneration of the arms are also represented for two typical individuals in Fig. 4, which gives two specimens, one from Series I (one arm removed) and the other from Series IV (four arms removed). In each of the individuals in Fig. 4 the condition of the arms 46 days after the operation is represented. Each of the four removed arms of the individual from Series IV has evidently regenerated more rapidly than the single removed arm of the individual from Series I.

In Fig. 2, Series I and IV, with respectively one and four arms removed, are compared. The individual cases are shown by dots. The abscissæ give the sizes of the animals as represented by the disk diameters in millimeters. The ordinates give the lengths of the regenerating arms also in millimeters. In the series where more than one arm was operated on the regeneration length as given is an average of all the regenerating arms of the individual. The individual cases of each series are connected by lines so as to give a basis for comparison of the two groups. The unbroken lines represent the lengths of the members of Series I and the dotted lines those of the members of Series IV. The upper two curves give the measurements as taken 22 days after the operation, the middle pair those at 33 days and the lower pair those at 46 days. In each group the curve showing the rate of regeneration of the arms in the series with four arms removed is well above the

one with only one arm removed. Fig. 2 likewise shows the increase in the rate of regeneration of the arms as we pass from the individuals with a smaller disk diameter to those with a medium disk diameter (about 12 mm.) which show the maximum rate. Then there is a decrease in rate of regeneration until indi-

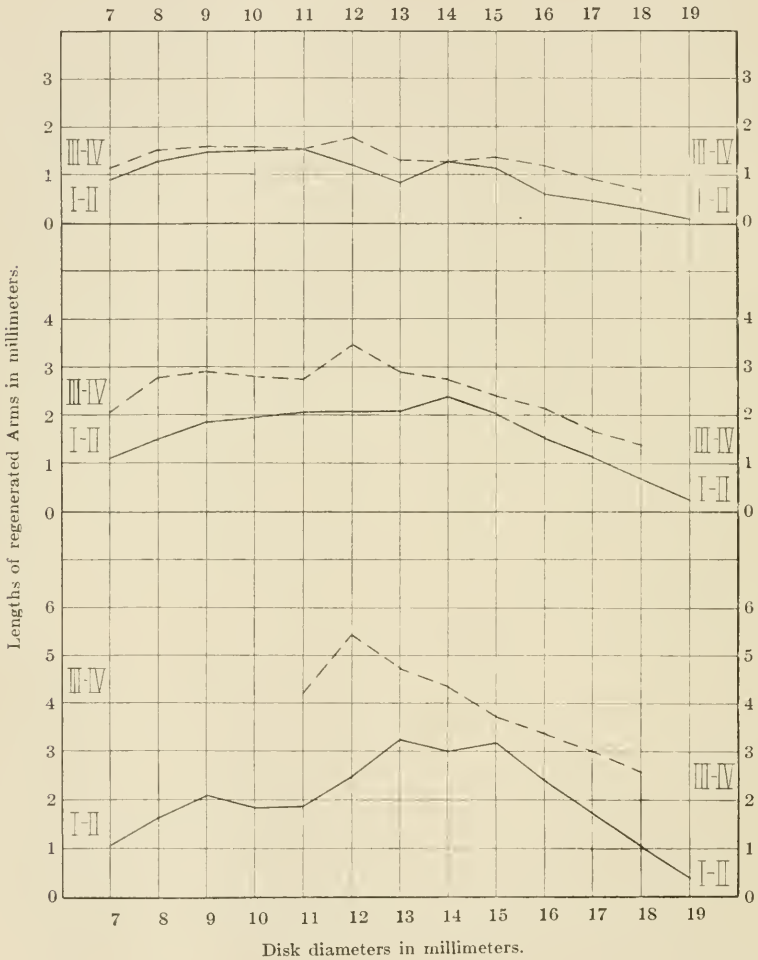

FIG. 3.

Brittle-star, *Ophioglypha lacertosa*. Comparison of lengths of regenerated arms in Series III and IV combined (three and four arms removed), dotted lines, with Series I and II combined (one and two arms removed), unbroken lines. Upper curves, 22 days; middle curves, 33 days; lower curves, 46 days after operation. The regenerated arm lengths are greater in Series III and IV than in Series I and II.

viduals of 19 or 20 mm. are reached when the regeneration length for 46 days arrives at a second minimum. A similar relation between rate of regeneration and disk diameter is shown in Fig. 3.

In Fig. 3 all the data for the Series I, II, III and IV are included. It was not, however, possible to put in the individual measurements without confusing the general effect of the curves. Therefore Series I and II are combined in one curve (the unbroken

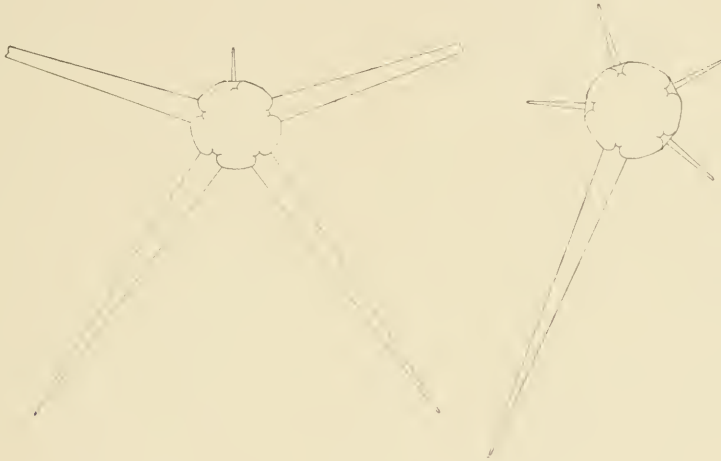

FIG. 4.

Brittle-star, *Ophioglypha lacertosa*. Left figure—Typical specimen with one regenerating arm. Right figure—Typical specimen with four regenerating arms. Both 46 days after operation. In left specimen two unoperated arms are shortened for lack of space in figure ( $\times 1\frac{1}{3}$ ).

line) and Series III and IV in another (the dotted line). As the individual disk diameters are not exactly equivalent in the different series, it was found convenient in taking the averages for the combination curves to use arbitrarily disk diameters equal to whole millimeters as the points for comparison. The values for such disk diameters are obtained from the separate curves constructed from the individual measurements for each series according to the method shown in Fig. 2. The average curve for Series I and IV in Fig. 2 would be one equidistant between them. The combination curves for Series I and II and Series III and IV, as given in Fig. 3, are constructed on this basis. The unbroken line gives

the average of the former group (one and two arms removed) and the broken line the average of the latter group (three and four arms removed).

### 3. Data.

The curves show very distinctly the correlation between the rate of regeneration on the one hand and the size of the animal and the number of removed arms on the other.

1. Taking up first the size correlation and using Fig. 3 as our basis of comparison, since it contains all the cases except those of Series V and therefore gives a more uniform and complete curve, we find that starting with the smaller individuals as we advance toward the larger ones there is a general increase up to a maximum at a diameter of 12 to 15 mm. This is most striking in the two later measurements, taken 33 days and 46 days after the operation. Thus in the 33-day measurement for Series I and II (Fig. 3), the regenerated length increases from 1.07 mm. for a disk diameter of 7 mm. to a maximum of 2.37 mm. for a disk diameter of 14 mm., and then goes down to .21 mm. for a 19 mm. diameter. Also for the Series III and IV at the same time the length increases from 2.04 mm. at a diameter of 7 mm. to a maximum of 3.45 mm. at a 12 mm. diameter, and down again to 1.36 mm. at a diameter of 18 mm. *The medium-sized individuals thus have the maximum rate of regeneration.*<sup>1</sup>

2. More striking still is the very constant difference between the regenerated lengths for Series I and those for Series IV in Fig. 2, and between the lengths for the combination of Series I and II and those for the combination of Series III and IV in Fig. 3. This shows a very decided advantage in favor of the animals with the greater number of removed arms. The difference is evident in the upper curves of Fig. 3 from measurements taken 22 days after the operation, but becomes more striking in the 33-day and 46-day curves. For example, in the 33-day curve for a 12 mm. diameter (the diameter at which we have the maximum rate of regeneration of Series III and IV) we get a regenerated length of 2.08 mm. for Series I and II, and of 3.45 mm. for Series

<sup>1</sup> Dr. Hans Przibram has called my attention to the fact that the specific rate of regeneration of the arms, *i. e.*, the amount of regeneration per unit of disk diameter as obtained from my data, does not show this increase from the smallest up to the medium-sized individuals, but gives a fairly constant figure up to 12 or 14 mm. The higher diameters then decline rapidly toward a minimum.

III and IV, an advantage of 1.37 mm. or 66 per cent in favor of the latter. Likewise, at a diameter of 14 mm. (where the Series I and II has its maximum regeneration) we get 2.37 mm. for Series I and II and 2.77 mm. for Series III and IV, an advantage of .4 mm. or 17 per cent in favor of Series III and IV. In a similar manner in the curves obtained from the 46-day measurements we get at a 12 mm. disk diameter a regenerated length of 2.46 mm. for Series I and II and 5.42 mm. for Series III and IV, and at a 15 mm. diameter 3.14 mm. for Series I and II and 3.72 mm. for Series III and IV, which represents an advantage for the group with the greater number of removed arms of respectively 2.96 mm. (= 120 per cent) and .58 mm. (= 18 per cent) for the two points named.

The difference between Series I and Series IV as represented in Fig. 2 is still greater. The regenerated lengths are on the whole at least twice as great in Series IV where four arms were removed as in Series I where only one arm was removed. Thus at a disk diameter of 8 mm. the regenerated length in Series I is 1.05 mm. and the average regenerated length in Series IV is 2.3 mm., an increase of 1.25 mm. or 119 per cent. For the same diameter at 33 days the respective values are 1.65 mm. and 4.4 mm., an increase of 2.75 mm. or 167 per cent. At 46 days the corresponding values are 2.0 mm. and 5.85 mm., an increase of 3.85 mm. or 192 per cent.

Likewise at a 12 mm. disk diameter for 22 days the values are .9 mm. and 2.1 mm., an advantage of 1.2 mm. or 133 per cent. At 33 days the values for a 12 mm. disk diameter are 2.3 mm. and 4.2 mm., an advantage of 1.9 mm. or 83 per cent, and at 46 days the corresponding values are 3.05 mm. and 6.5 mm., an advantage of 3.45 mm. or 113 per cent.

We may sum up the results on the rate of regeneration of the arms of the brittle-star, *Ophioglypha lacertosa*, as follows:

1. There is a definite relation between the size (*i. e.*, age [?]) of the animal and the rate of regeneration of its arms. The maximum rate is exhibited by individuals of medium size (with a disk diameter of 12 to 15 mm.). Both the smaller and the larger ones give a diminishing rate as we go away from this point.

2. The greater the number of removed arms (excepting the case where all are removed) the greater is the rate of regeneration of each arm.

4. *Discussion.*

We must, therefore, conclude that when more than one arm is removed the regenerative energy as expressed in the replacement of the lost arms is greatly increased. Not only is the total regenerative energy greater in this case, but the energy expressed in each arm is greater than the total energy when only one arm is removed.

Expressing this in mathematical form, if  $E_1$  represents the regenerative energy exhibited in the replacement of the lost arm when only one is removed, assuming that increase in length is a measure of such energy, and  $E_n$  represents the energy exhibited in regeneration when more than one arm is removed,  $n$  being the number of absent arms, then not only is  $E_n > E_1$  but also

$$\frac{E_n}{n} > E_1 \text{ or } E_n > n E_1.$$

Therefore, when we remove  $n$  arms we increase the total regenerative energy by more than  $n$  times the amount exhibited when only one is removed. The force of this statement is made especially strong when we consider that throughout the experiments the animals received no food supply whatever.

Expressing the relation in still another way, let us take a brittlestar with arms  $A, B, C, D$  and  $E$ , in which  $a_1, b_1, c_1, d_1$  and  $e_1$  represent the respective lengths these arms will attain after a definite period of regeneration, supposing that one alone is cut off in each case. Now let us suppose instead that the first four are cut off, then after this same period of time we get for the regenerated lengths  $a_4 > a_1, b_4 > b_1, c_4 > c_1, d_4 > d_1$ . Now in the first case we cannot assume that the stimulus of removal and the resultant reaction of regeneration are purely local and concern only the tissues in the immediate vicinity of the cut surface, for we then get into difficulty as soon as we try to explain the cases where four arms are simultaneously removed. Here we find we must add a considerable quantity ( $r_4$ ) to each of the original single regeneration lengths to get the new regeneration length, *e. g.*,  $a_4 = a_1 + r_4$ . Then  $a_4 + b_4 + c_4 + d_4 = a_1 + b_1 + c_1 + d_1 + R_4$  where  $R_4 (= \Sigma r_4)$  represents the total response of the organism as a whole which must be added to the local effects of the operation stimulus. If, on the other hand, we consider the influence of the organism as a



whole on the regeneration of its arms as one of retardation, we must take the values  $a_4$ ,  $b_4$ ,  $c_4$  and  $d_4$  as representing most nearly the original local stimulus effect. Then without changing the values of  $r_4$  or  $R_4$  we may rearrange the formulæ, making  $a_1 = a_4 - r_4$ , etc., and  $a_1 + b_1 + c_1 + d_1 = a_4 + b_4 + c_4 + d_4 - R_4$ .

The regeneration of the arms of *Ophioglypha* thus offers us a very good example of the influence of conditions away from an injured surface upon the regeneration at that surface. The result may be stated in two ways and each mode of statement may be made to lead to a separate mode of interpretation.

*We may say that the rate of regeneration increases with an increase in the number of removed arms.* With this statement as a starting point it is natural to assume that, in the cases where more than one arm is removed, the stimulus of the additional operations or of the additional regenerating organs exerts an accelerating influence upon the regenerating tissues at any one such surface.

Another mode of statement is the following: The increase in the number of removed arms is necessarily accompanied by a decrease in the number of uninjured arms present, and *the rate of regeneration of a removed arm therefore increases as the number of uninjured arms still remaining decreases.* If the uninjured arms exert a retarding influence upon the regenerating tissue at an injured surface we can understand why a removal of additional arms may bring about an increase in rate of regeneration of each. The discussion of this interpretation involves the whole problem of nutrition and perhaps the whole general problem of form regulation as well. It will be best to reserve further discussion until we have examined the other experiments to be described in the following pages.

But whether we consider the influence of the organism as a whole to be one of acceleration or one of retardation, we must recognize in either case that the regeneration rate is not a matter which involves only the local conditions at the wounded surface as determined by the direct action of the operation. It seems, on the other hand, to be bound up with intricate reactions affecting the whole character of the activities and organization of the animal.

## III. THE OPERCULA OF SERPULIDS.

We have now considered a case (section one) in which there is a readjustment in the uninjured portions of a system as a result of their mutual interaction. This interaction is not complicated by the addition of a regenerating organ. The result is a new system in equilibrium, based on the resultant of the interactions of the uninjured parts.

In a second section (section two) a case was considered in which it was possible to study the effect of the presence or absence of uninjured portions of the animal upon the rate of regeneration of the removed ones. The reaction is here more complicated than in the first case, because there may be here an action of other regenerating surfaces upon any particular wounded surface as well as the action of the uninjured organs themselves.

In the present section (section three) a case will be considered in which there are two organs, dissimilar in size, situated on morphologically similar opposite sides of the median line. An extremely close interaction is found to exist between these two organs so that any disturbance in one is reflected in changes in the other. This close interrelation between the opercula of the Serpulids, the organs in question, gives a good basis for the study of such interactions as were outlined in the general introduction. The opercula of the Serpulids furthermore furnish exceptionally good material for this study of compensatory regulation because of the various degrees of asymmetry present in the different species.

In the following account it will be necessary to go into paths not in the line of the main discussion, but such a course cannot be avoided in a study of the factors controlling the regulation of the opercula.

In the adult Serpulids of the genus *Hydroides* we have an asymmetrical stable system with the functional operculum on the right side and the rudimentary operculum on the left or vice versa. The nature of this case will first be taken up. Then the opercula of other members of the family will be described. This will be followed in turn by a description of the ontogenetic development, the regeneratory development, some speculations as to the probable phylogenetic development, a discussion on the comparison of regeneratory, ontogenetic and probable phylogenetic develop-

ment and finally by a discussion of the facts of compensatory regulation as here exhibited.

In a separate section (section four) a special series of experiments on the regulation of the rate of differentiation of the opercula in the Serpulid, *Apomatus ampullifera*, will be treated.

1. *Comparative Anatomy.*

1. The Genus *Hydroides*.

The opercula and branchiæ of the genus *Hydroides* will serve as the type in our description of the anatomy of these structures throughout the family. The branchiæ are brought in only incidentally as our main purpose is to get the details of the structure of the opercula to serve as a basis for the regeneration and regulation experiments to be described later. Unless otherwise stated the description applies to *H. dianthus*. *H. uncinata* and *H. pectinata*, living in the Mediterranean at Naples, were also used in the experiments and the differences will be pointed out at the close of the special description. *H. dianthus* is found on the Atlantic coast of North America living attached to stones, mollusk shells and other hard materials, from low water mark to a depth of several fathoms. The worm lives in an irregularly twisted calcareous tube which is attached by its side to the supporting surface. The tube increases in size from the posterior end anteriorly and is continually being built up at the anterior end by additions from the special calcareous glands.

The body of the animal is very distinctly divided into the thorax and the abdomen. The first-named region is marked by the presence of the broad, flat fold of the thoracic membrane, which is continued at both the anterior-ventral and the posterior-ventral ends as a projecting membrane. At the anterior end this membrane forms a collar which, except for a slight break on the dorsal side, completely surrounds the head end. (See Fig. 5A.)

Upon the anterior surface thus enclosed by the collar are located the two semicircular rows of branchiæ, one on each side of the mouth, which apparently serve on the one hand as organs of respiration and on the other through their cilia as agents for the creation of a current of water carrying food particles to the mouth. The two rows of branchiæ are placed on slight ridge-like elevations, the branchial ridges. These are not strictly semicircular

in shape but the ends of each are curved inward. This shape evidently has some connection with the proper collection of the food particles carried downward by the cilia. (See Fig. 5B, C.) The number of the branchiæ increases with the age of the animal and in fully grown individuals there are about fourteen on each side.

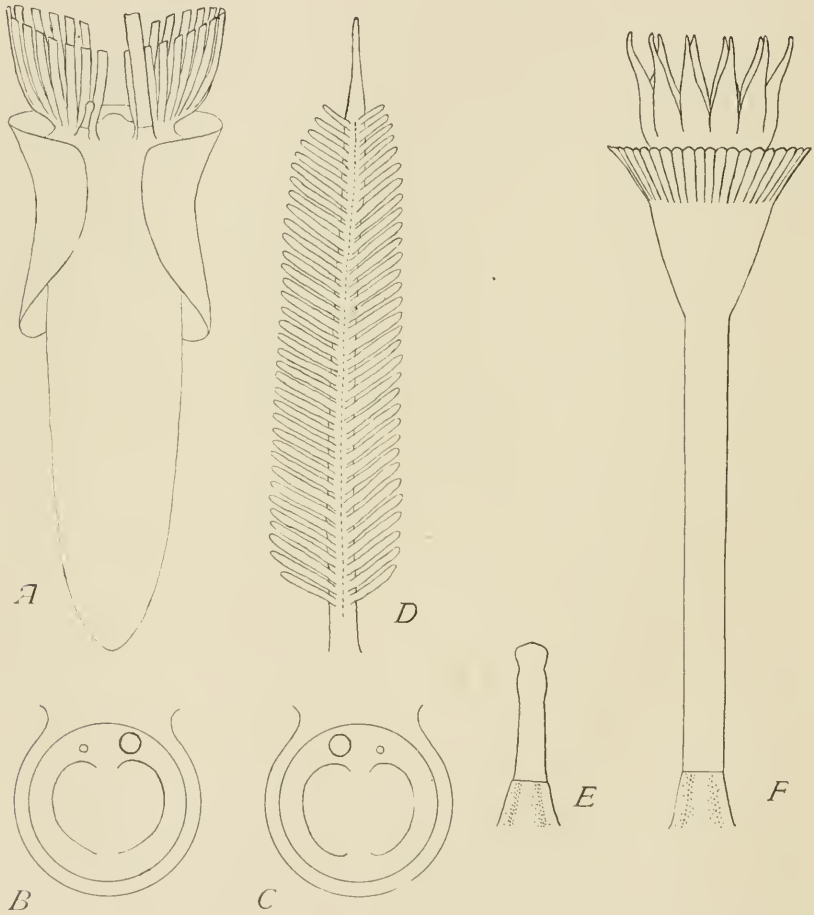

FIG. 5.

Hydroides dianthus. *A*—Dorsal view of right-handed specimen, showing relations of parts. Ends of branchiæ and functional operculum not given ( $\times 6$ ). *B, C*—Diagram of anterior surface of head of left-handed and right-handed specimens ( $\times 6$ ). *D*—Branchia viewed from inner surface ( $\times 25$ ). *E*—Rudimentary operculum ( $\times 30$ ). *F*—Functional operculum ( $\times 30$ ).

Each branchia consists of a long axis bearing two rows of secondary processes, the pinnules. (See Fig. 5D.) The axis is continued for a short distance beyond the region of the secondary processes as a slender tapering thread. The pinnule rows slope inward so as to inclose a trough-like area, V-shaped in cross section and with the cavity of the trough pointing inward, *i. e.*, toward the mouth. The surfaces bordering this area are ciliated and it is along them that the food-bearing currents are formed.

Near the dorsal end of one of the branchial ridges, not in the line of the branchiæ but dorsal to it, there is a stout, naked stalk of approximately the same length as a branchia but bearing at its distal end a funnel-shaped expansion. (See Fig. 5F.) The whole organ constitutes the functional operculum. The edge of the expanded portion is marked by teeth-like serrations, the hollows between which are continued for some distance down the outside. From the center of the terminal circular area within this row of serrations there arises a group of secondary processes, arranged so as to form a cup-shaped figure. The ends of the processes are usually hooked and considerable foreign material often clings to them. The whole organ serves as a very efficient plug for the open end of the tube when the animal has retired within for protection. An examination of the place of attachment of the opercular stalk shows that it is located dorsal to the first branchia or sometimes nearly opposite the interval between the first and second branchiæ. Near the base of the stalk there is a transverse suture varying in distinctness in different cases and which, as we shall see later, is a "breaking joint," an important structure in the experiments.

On the opposite side of the mid-dorsal line, and in a position corresponding in all respects with that of the large operculum, is a small organ consisting of a slender stalk with a slight terminal enlargement. (Fig. 5E.) It also shows a distinct line of demarcation between a darker colored more basal region and the lighter remainder of its body. This small organ, the "pseudopercule" of de St. Joseph is most commonly called the rudimentary operculum.

A study of the relative positions of the opercula is interesting. An examination of 244 adult individuals of *H. dianthus* gave 139 or 57 per cent with the functional operculum on the right side and 105 or 43 per cent with it on the left. The distribution between

right and left is thus fairly equal though there is a considerable advantage in favor of those with the functional operculum on the right side and the rudimentary on the left. Similarly in *H. uncinata* out of 16 specimens ten had the functional operculum on the right side and six on the left, and in *H. pectinata* out of 41 specimens 21 were right handed and 20 left handed.

An examination of the internal structure of the branchiæ and opercula brings out a close agreement between the two in anatomical details. Their morphological agreement has been especially emphasized by Örley and Meyer. Örley ('84) compares the internal anatomy of the branchia and the functional operculum in *Serpula*. He makes no mention of the rudimentary operculum. According to him an operculum corresponds morphologically with a branchial stalk, all the pinnules of which have been collected at the end in one bundle. He describes the presence of an axial blood vessel in both branchial and opercular stalks. In the branchial stalk, however, he saw only one nerve trunk (the axial one) while in the opercular stalk two lateral ones were shown. Meyer ('88) showed the more complete similarity of the branchia and operculum in *Eupomatus uncinata* (= *Hydroides uncinata*), while at the same time pointing out the incompleteness of Örley's observations and the error in his mode of homology. He describes three nerve trunks in both branchiæ and operculum, although the middle one is very small in the opercular stalk and does not reach much more than halfway to the distal end. In the branchia the two lateral ones likewise are very insignificant. Meyer points out that this difference is probably due to the fact that the pinnules and ciliated groove are innervated from the middle nerve, so that this has a greater development in the branchiæ where pinnules and ciliated groove are present than in the opercular stalk where they are absent. The stalk of the operculum is thus made directly homologous with a branchial axis lacking its pinnules.

A study of the internal structure of the branchiæ and opercula of *Hydroides dianthus* brings out points which are in entire agreement with the conclusions of Meyer and which emphasize the close similarity of the branchiæ and opercula.

An interesting characteristic is further made out in the functional operculum. There is a difference between the cells near the basal region and those in the middle and terminal regions of the stalk. Near the base of the stalk in the region below the

“breaking joint” the cells of the connective tissue have more of an embryonic character than elsewhere, having fewer and shorter processes and less intercellular material. This distinction has already been noted by Orley ('84) in his description of the connective tissue of the opercular stalk in *Serpula vermicularis*. He says, speaking of this tissue, “Die Modificationen dieses Bindegewebes sind nach den Ortsverhältnissen sehr verschieden. *Im innersten Theile des Stieles* wo dieser mit dem Kiemenlappen zusammen hängt, findet man kleine weniger verzweigte Zellen in der sehr spärlichen Intercellularsubstanz. *Es ähnelt sehr der embryonalen Form.* Etwas höher trifft man bereits Zellen an, die sich durch Grösze und durch die Zahl ihrer Ausläufe auszeichnen und eine gut entwickelte Intercellularsubstanz haben.”<sup>1</sup> The significance of the differences of the regions will be brought out in connection with the experiments described later in the paper (p. 55).

The rudimentary operculum of *H. dianthus* has two well-defined regions. The cells distal to the “breaking joint” are distinctly embryonic in form and general character. Those proximal to the breaking joint have among them well-developed supporting cells of the type found in the branchiæ and functional operculum, though these cells are not as highly differentiated as in the latter organs.

A comparison of the two other members of the genus *Hydroides* with *H. dianthus* brings out only slight differences in the character of the opercula and branchiæ. *H. pectinata*, however, has pectinate secondary processes as opposed to the unbranched ones of *H. uncinata* and *H. dianthus*.

Any conclusion drawn from direct anatomical evidence must emphasize a very close resemblance in the internal structure as well as in the position of the opercula and branchiæ. A similar conclusion as regards the morphological worth of the rudimentary operculum can be reached by a recognition of similarity in position on the one hand and the nearly equal appearance of right and left-handed individuals on the other.

The functional operculum in *Hydroides* is therefore morphologically a branchia which has formed an expansion at its distal end and which has at the same time lost its respiratory pinnules.

<sup>1</sup>Italics mine.

The increase in strength of the supporting axis is a necessary concomitant of the other changes.

The rudimentary operculum cannot be compared directly with a branchia because of its bud-like appearance and embryonic tissues. In position it, however, corresponds perfectly with the functional one and therefore with the branchiæ as well.

## 2. Other Genera of Serpulids.

An examination of the different groups of Serpulids brings out the fact that we have almost all gradations between forms with no opercular modification of the branchiæ and forms with the single operculum possessing scarcely any trace of a branchial character.

*a. Group I. No Opercular Differentiation.* Examples of Serpulids with no opercular modification of the branchiæ are *Protula* (Risso) and *Protis* (Ehlers). Each branchia possesses respiratory pinnules and tapers to a point at its distal end. The branchiæ resemble one another throughout both right and left circlets. The members of this group are able to retreat for a long distance back into the tube, in this respect resembling the Sabellids which also have no opercula. (See Fig. 6A.)

*b. Group II. Each Branchia with a Terminal Enlargement.* In *Salmacina Dysteri* Huxl. there are eight branchiæ, four on each side and each has a terminal club-shaped enlargement. The branchial stalk or axis has from fifteen to twenty pairs of ciliated pinnules. The two rows of pinnules are bordered on the outside by enlarged mucous cells which near the distal end spread out along the sides of the club. This enlarged region bears no pinnules. The eight branchiæ are similar in their characters. It is evident that when the animal retreats into its tube these enlarged ends must collectively serve as a stopper for the opening and thus barricade the end more effectively than those of *Protula* which bear no such enlargements (Fig. 6B).<sup>1</sup>

*c. Group III. Two Equal Opercula, Right and Left, on Ends of Branchiæ. Branchial Pinnules Present.* *Filograna implexa* resembles *Salmacina* in having eight branchiæ. The dorsal one on each side is, however, terminated by a small, transparent, chitinous, spoon-shaped structure obliquely attached to the side of the tip of the axis of the branchia. The other branchiæ end

<sup>1</sup>de St. Joseph, however, seems unwilling to admit an opercular function for these structures.



in short blunt points. The two opercula are equal in size and the stalks which bear them retain the pinnules and other branchial characters (Fig. 6c). When the animal has withdrawn into its tube the branchiæ are twisted in spiral form and the two opercula are superimposed, the one upon the other. The more anterior



FIG. 6.

*A*—End of branchia of *Protula*. *B*—Club-shaped end of branchia of *Salmacina* (after de St. Joseph). *C*—One of the two opercula of *Filograna* (after de St. Joseph). *D*—Tip of non-operculate branchia of *Apomatus ampullifera* ( $\times 17$ ). *E*, *F*—Tip of rudimentary operculum (*E*) and functional operculum (*F*) of same ( $\times 17$ ). *G*—Distal portion of functional operculum of *Serpula vermicularis* ( $\times 19$ ).

one closes the tube after the manner of forms with but one operculum. The more posterior operculum, therefore, serves as a protection only in the cases where the barricade formed by the first is not effective. As compared with *Salmacina*, to which it is otherwise closely related, *Filograna* has two, more effective oper-

cula instead of eight less effective club-shaped enlargements. The fact that when the animal is retracted the expanded portion of one operculum occupies a position in front of the other may be of importance in connection with a theory of the development of asymmetry in these organs in other members of the group.

*d. Group IV. One Functional Operculum and One Rudimentary Operculum. Both on ends of Branchiæ. Pinnules present. Examples—Apomatus, Josephella.*

In *Apomatus* the next to the dorsal branchia on either the right or the left side is expanded at its end into a globular almost transparent operculum. The chitinous shell of the sphere itself contains irregularly branched blood vessels, the green-colored blood of which makes them very conspicuous. The branchia in a corresponding position on the opposite side has a small ovoid enlargement with a very pronounced network of blood vessels containing distinctly pulsating green blood. Both these opercula are placed at the ends of stalks which retain all the branchial characters in an unchanged condition.<sup>1</sup> (Fig. 6D, E, F.)

In a few cases the branchia occupying the place of the rudimentary operculum ended in a tapering point instead of an ovoid enlargement. There are usually about twenty pairs of branchiæ in the adult. Each of the two circlets breaks off very readily along a definite breaking plane level with the anterior surface of the head. The division plane is very pronounced and the break is clean cut and takes place so readily that it is very hard to remove the animal from its tube without causing it to throw off both of the branchial circlets.

*e. Group V. One Functional Operculum and One Rudimentary Operculum. Functional Operculum with Naked Stalk. Rudimentary Operculum Not on End of Long Stalk. Examples—Serpula, Crucigera, Hydroides.*

The description given above for *Hydroides* (p. 21) is sufficient as a general characterization of this type. The functional operculum may be either on the right or on the left side, the rudimentary operculum in each case occupying the opposite position. The opercula are not in the line of the branchiæ but occupy a position

<sup>1</sup>According to de St. Joseph ('94) the functional operculum appears on the left side and the rudimentary, his "pseudopercule," on the right. He does not mention the possibility of the reverse arrangement. The specimens which I examined at Naples showed a preponderance of the right-handed condition. (See p. 32.)

dorsal to the first dorsal branchiæ or to the interval between the first and second dorsal ones. *Serpula* differs from *Hydroides* in the entire absence of the secondary group of processes in the operculum (Fig. 6G). *Crucigera* has only four secondary processes and these are arranged in the form of a cross (de St. Joseph, '94).

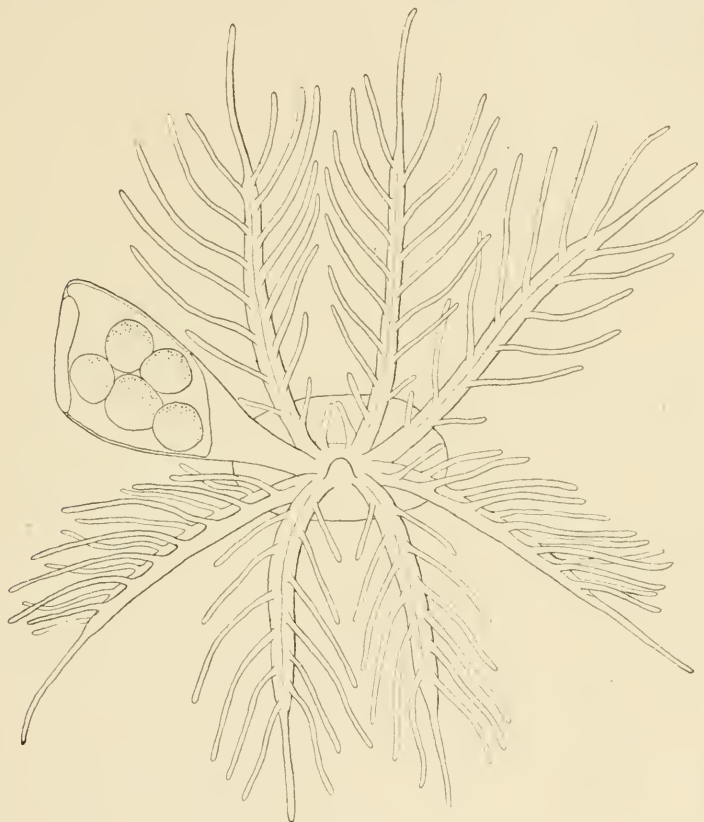

FIG. 7.

*Spirorbis Pagenstecheri*. Ventral (slightly anterior) view showing branchiæ and operculum with its brood chamber containing embryos ( $\times 40$ ).

*f. Group VI. One Operculum. No Rudimentary Operculum.* The members of this group have only one operculum. There is no rudimentary operculum. Examples are *Spirorbis*, *Pileolaria*, *Ditrupa*, *Filigranula* (?), *Pomatoceros*, *Vermilia*.

This group may be further subdivided according as the operculum has a position in the line with the branchiæ (*Ditrupa*,

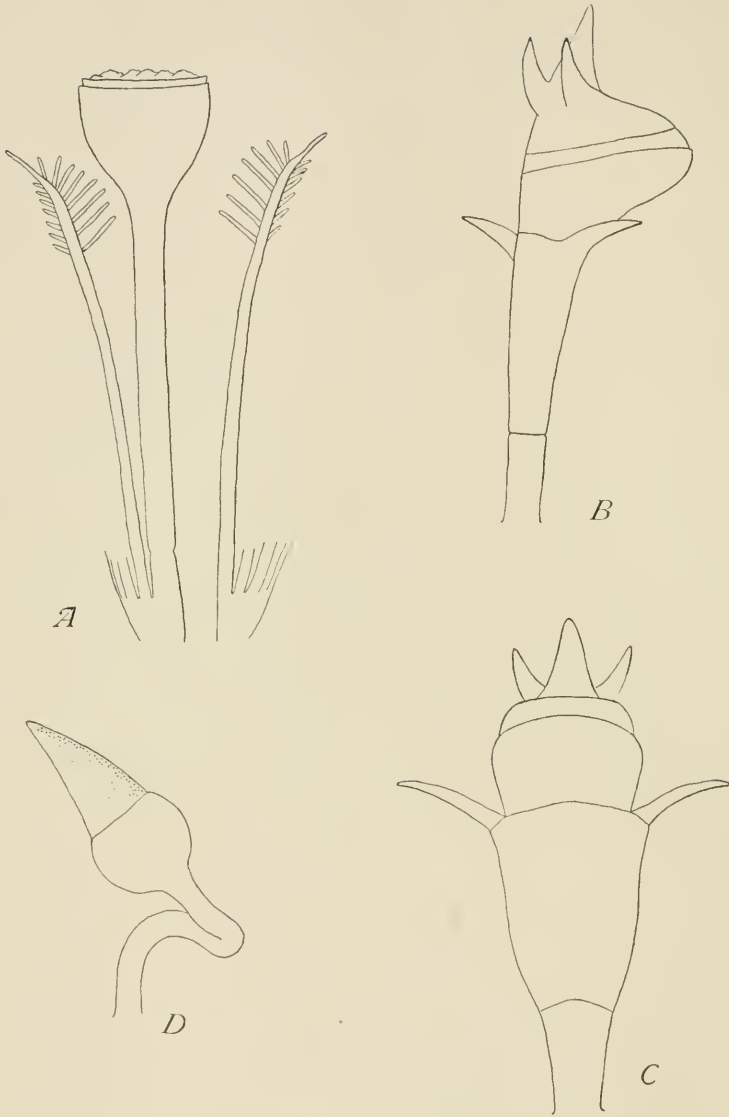

FIG. 8

*A*—*Ditrupa subulata*, showing single naked stalked operculum in line with branchiæ of left side. Dorsal view. Note indication of basal suture ( $\times 15$ ). *B, C*—Side view and dorsal view of operculum of *Pomatoceros triquetroides*, showing highly modified terminal and lateral spines. Basal suture present ( $\times 10$ ). *D*—Operculum of *Vermilia multivaricosa*, showing curved stalk and absence of a basal suture. Dorsal view—Left-handed individual ( $\times 8$ ).

Spirorbis, Pileolaria, Filogranula [?]) or dorsal to the line of the branchiæ (Pomatoceros, Vermilia and others). In the latter case the operculum may further be either at one side of the median line (most species of Pomatoceros and Vermilia) or in the middle line itself (Pomatoceros elaphus, Haswell).

In Ditrupa there is a large cup-shaped operculum with a naked stalk situated on the left side in line with the branchiæ. It occupies a position on the median side of the most dorsal branchia of that side (Fig. 8A). I had only four specimens for examination. In all of these the operculum was on the left side, but whether this was merely a coincidence or not it is impossible to say. The tube of Ditrupa subulata lies freely on the sea bottom usually at a considerable depth. Its substance is extremely hard and difficult to break. The tube is slightly curved and resembles very much the shell of the mollusk Dentalium.

The Spirorbis-like forms (Spirorbis, Pileolaria, etc.) have closely coiled tubes attached by the dorsal side to a flat surface. In some the tube is attached for its whole length but in others (some species of Pileolaria) the end may rise up from the level of the surrounding surface. The direction of the coil of the tube is constant for any one species but varies in the different species. Thus dextral and sinistral species are distinguished according as the tube is coiled clockwise or counter clockwise. The dorsal side of the animal is next to the attached surface and the posterior end of the animal upon removal has a pronounced curve to the right or left according as the tube is dextral or sinistral. In the dextral species the operculum is on the right side and in the sinistral on the left so that in all cases the operculum is on the side next to the concave curve of the shell. The number of branchiæ varies in the different species from five to twelve, according to Caullery and Mesnil ('96). Of the two species examined by me Spirorbis Pagenstecheri had four branchiæ on the left side and three plus the operculum on the right and Pileolaria sp. had five branchiæ on the right and four plus the operculum on the left. In both cases the operculum occupies the position of the next to the dorsal branchia on its side, *i. e.*, the right side in Spirorbis and the left side in Pileolaria. In all members of the group the operculum is in line with the branchiæ. It is as a rule much smaller than the opening of the tube so that the animal can retreat to a considerable distance within the tube. There is no sign in either of the two

genera of any modification of the branchiæ to compare with the rudimentary operculum of *Apomatus* or *Hydroides*. The right or left position of the operculum is definitely correlated with the direction of curvature of the tube and as the latter is constant for any one species the former must be also. In *Spirorbis Pagenstecheri* the operculum serves as a brood pouch and is of a trumpet shape. The branchial pinnules are comparatively large and it is sometimes hard to tell whether a basal pinnule should or should not represent a branchial stalk. (Fig. 7.) *Pileolaria* sp. also uses its operculum as a brood pouch. Other species, however (*S. borealis*, for example, according to Alex. Agassiz, '66), keep the eggs in a string within the tube on the ventral side of the body.

Next comes the group in which the single operculum does not occupy the line of the branchiæ but is dorsal to it. First are the cases in which it is lateral. In *Pomatoceros triquetroides* the operculum is very large and stout. There are two lateral processes beyond which comes an expansion ending in a cap of three spines. There is a very pronounced suture near the base. The whole region below the two lateral processes is flattened dorso-ventrally. In the cases examined the operculum was always on the left side (Fig. 8B, c).

In *Vermilia multivaricosa* the operculum occupies a position corresponding with that of *P. triquetroides* but it may be either on the left or on the right side. The stalk of the operculum is approximately circular in cross section though possessing a corrugated outer surface. It loops around from its point of attachment toward the median line. The terminal region is thus brought nearer to the median line than is the proximal region. The terminal portion is very large and heavy. There is a basal globular portion upon which rests a heavy cone-shaped body (Fig. 8D).

Haswell ('85) describes a species of *Pomatoceros* (*P. elaphus*) with a large median operculum which is short and flattened dorso-ventrally. At the sides of the proximal portion are two wing-like lobes bearing small processes. Terminally there are three processes with antler-like branches. In another *Serpulid* (*Vermilia cæspitosa*), according to Haswell, there is also a large operculum on a short stubby stalk (but not median judging by the figure, though there is no statement in the paper on this point). This operculum is armed terminally with peculiar spines and serrated

processes and also has two lateral wings like those of *Pomatoceros elaphus* but not as well developed as the latter. E. Meyer ('88) concludes that these opercula have been formed by the union of two lateral ones, but the evidence as regards this point is by no means conclusive, since we have species where similar opercula are evidently lateral in position (*P. triquetroides* and *V. multivaricosa*, for example).

*g. Summary.* The principal modifications of the opercula throughout the family of Serpulids have now been passed over briefly and the general characters may be summarized. In the *first* group are the forms with no opercular modification (*Protula*, *Protis*). In the *second* each branchia has a small club-shaped enlargement, the combination of the enlarged ends no doubt making a more or less effective barricade against invaders when the animal has retreated into its tube (*Salmacina*). In the *third* group (*Filograna*) the modification is confined to the most dorsal branchia on each side. All the others lack opercular differentiations. The two dorsal ones mentioned also retain their branchial characters, but in addition each has an operculum of sufficient size to close up the opening of the tube. In the *fourth* group (*Apomatus*, *Josephella*) there is one functional and one rudimentary operculum, one on the end of each of the two next to the dorsal branchiæ. The stalks supporting these opercula retain their branchial pinnules and other branchial characters. In the *fifth* group (*Serpula*, *Crucigera*, *Hydroides*) there are likewise one functional and one rudimentary operculum, the distribution between right-handed and left-handed forms being fairly equal in adults. The opercula, however, do not possess branchial pinnules though their internal anatomy and position indicate branchial characters. The rudimentary operculum is not situated on the end of a long stalk but is a small bud-shaped organ corresponding in position with the functional operculum. Judging by their position the opercula seem to have moved down from the interval between the most dorsal and the next to the dorsal branchiæ on each side. Finally in the *sixth* group there is only one operculum and this retains but little of its branchial character. In some of the group, however (*Ditrupa*, *Spirorbis*, *Pileolaria*), it retains its position in the branchial circlet. In some cases it may be used as a brood pouch (*Spirorbis*, *Pileolaria*). In other forms (*Pomatoceros*, *Vermilia*) it is a considerable distance below

the branchial region and is large and massive. In some of the species as *P. triquetroides* and *V. multivaricosa* it has a lateral position and in others, as *P. elaphus*, a median one.

*These six groups form a very complete morphological series which points strikingly toward the homology of the opercula and branchiæ in all the forms.*

### 3. Distribution of the Opercula between Right and Left Sides.

The data upon this point will be presented under this separate heading because of their special interest in connection with later discussions. The first three of the groups of Serpulids mentioned above exhibit no asymmetry in their opercula and need not be considered here. The three others will be discussed in turn:

*a.* The *fourth group* have one functional and one rudimentary operculum. Both opercular stalks have branchial pinnules. (Examples—*Apomatus*, *Josephella*.)

*b.* The *fifth group* have one functional and one rudimentary operculum, each with a naked stalk. Rudimentary operculum not on end of a long stalk. (Examples—*Serpula*, *Crucigera*, *Hydroides*.)

*c.* The *sixth group* have only one operculum. No rudimentary operculum is present. (Examples—*Ditrupa*, *Spirorbis*, *Pileolaria*, *Pomatoceros*, *Vermilia*.)

(*a.*) In the *fourth group* thirteen specimens of *Apomatus* were examined and of these *ten* had the functional operculum on the right side and the rudimentary on the left. The other three had the reverse condition with the functional on the left and the rudimentary on the right.

TABLE II.

	Total No.	F = Right R = Left	F = Left R = Right
<i>Apomatus ampullifera</i> .....	13	10	3
Per cent .....	—	77	23

(*b.*) In the *fifth group* *Hydroides dianthus*, *H. uncinata*, *H. pectinata* and one specimen of *Serpula vermicularis* were exam-



ined for the distribution of opercula. By far the most extensive observations are on *Hydroides dianthus*.

TABLE III. *Hydroides dianthus*. Position of Opercula.

Locality and Date.	Total No.	F = Right. R = Left.	F = Left. R = Right.	Not like other two groups.
Woods Hole, Mass. . . . . 1901/IX/16-IX/19.	57	31	24	2*
Cold Spring Harbor, L. I. . . . 1902/VII/5-6-7.	74	39	30	5†
Cold Spring Harbor, L. I. . . . 1902/VIII/9 to 20.	120 + †7‡	69	51	†7‡
	251 + †7			7 + †7
Total. . . . .	=258	139	105	=14
		53.9%	40.7%	5.4%

EXPLANATION OF TABLE.

F = Functional operculum; R = Rudimentary operculum.

\*These two specimens had a rudimentary operculum on each side.

†These irregulars come under four heads: 1. *One* specimen with Right = operculum missing; Left = operculum between rudimentary and functional stage. 2. *One* specimen with Right = between rudimentary and functional; Left = rudimentary operculum. 3. *Two* specimens with Right = functional operculum; Left = two-thirds developed functional. 4. *One* specimen with Right = rudimentary; Left = one-half developed functional.

‡In this case the number of unclassified irregular cases was unfortunately not put down. My notes give only the indefinite statement "several abnormal and incomplete ones observed are not included in the present list." Assuming that the percentage of such cases is the same as in the other two groups, where it is 5.4 per cent of the total number, we will not be far astray in making the unknown number equal to seven.

The relative relation between right-handed and left-handed forms is expressed to better advantage if the irregular cases are not included. Removing the last column from the former table we get the relations expressed in the following one:

An examination of this table shows that 57 per cent of the "normal" cases have the functional operculum on the right and the rudimentary on the left, while 43 per cent have the opposite arrangement. The striking agreement in the three sets of figures,

one from Woods Hole and the other two from Cold Spring Harbor, indicates the probability of some organic basis back of the fact. This matter will come up again later in the discussion of the development in ontogeny and during regeneration. At the same time the considerable number of cases (fourteen [?] or 5.4 per

TABLE IV. *Hydroides dianthus*. Position of Opercula (not including irregular ones).

Locality and Date		F = Right R = Left	F = Left R = Right	Total
Woods Hole, Mass.,	No.	31	24	55
1901/IX/16-19 .....	Per cent	56.4	43.6	—
Cold Spring Harbor, L. I.,	No.	39	30	69
1902/VII/5-6-7.....	Per cent	56.5	43.5	—
Cold Spring Harbor, L. I.,	No.	69	51	120
1902/VIII/9-20.....	Per cent	57.5	42.5	—
	No.	139	105	244
Total.....	Per cent	57	43	—

TABLE V. *Hydroides uncinata*. Position of Opercula.

Locality and Date		F = Right R = Left	F = Left R = Right	Total
	No.	10	6	16
Naples, 1902/XI/21 .....	Per cent	62.5	37.5	—

cent of the whole number) which do not come under either of these groups will be taken up.

Sixteen specimens of *Hydroides uncinata* were examined at Naples. Of these ten, or 62.5 per cent, had the functional operculum on the right and the rudimentary on the left, and six, or 37.5 per cent, had the reciprocal arrangement; a considerable advantage in favor of the right-handed ones.

Likewise 41 specimens of *Hydroides pectinata* were examined at Naples, and of these 21 or 51.2 per cent had the functional operculum on the right side and the rudimentary on the left while 48.8 per cent had the reciprocal arrangement, a slight advantage in favor of the right-handed ones.

TABLE VI. *Hydroides pectinata*. Position of Opercula.

Locality and Date		F = Right	F = Left	Total
		R = Left	R = Right	
Naples, 1902/IX/27	No.	21	20	41
1903/III/31 .....	Per cent	51.2	48.8	—

In *Serpula vermicularis* I examined only one specimen and this had the functional operculum on the left side and the rudimentary on the right.

Our general conclusion regarding the distribution of the opercula in the *fifth* group of Serpulids, those with the naked-stalked functional and small bud-like rudimentary is that the right and left-handed forms are nearly equal in number, but there is a slight advantage in favor of the right-handed ones.

(c.) In the *sixth* group there is only one operculum.

In *Ditrupa subulata* only four specimens were examined as regards this point. All four of these had the operculum on the left side.<sup>1</sup>

In the dextrally coiled *Spirorbis Pagenstecheri* eleven specimens were examined and all had the operculum on the right side, while in the sinistrally coiled *Pileolaria* the one specimen examined had the operculum on the left. The observations of Caullery and Mesnil ('96) show that in the species with dextrally coiled tubes the operculum is always on the right side and in the sinistrally-coiled ones always on the left side.

<sup>1</sup>de St. Joseph ('98) gives a description of *Ditrupa arietina*, O. F. Müller (= *D. subulata*, Desh.) in which he mentions the operculum as a structure of the left side in agreement with the present observations. Also the left side according to him has one less branchia than the right, *i. e.*, there are 11 branchia (plus the operculum) on the left and 12 on the right.

In *Pomatoceros triquetroides* 21 specimens were examined and all had the operculum on the left side. This makes a fairly strong probability in favor of the permanence of such a characteristic. As a further argument may be mentioned the statement of de St. Joseph ('94), who mentions the observation of Grube on 63 specimens of *P. triqueter*, L. (= *P. triquetroides*, D. Ch.) and of himself on many more than this number which showed the operculum in every case on the left side, so that we may be fairly certain that in this species the organ is a permanent structure of the left side.

In *Vermilia multivaricosa* eleven specimens were examined. Six had the operculum on the right and five on the left side. In this case, therefore, there seems to be a fairly equal distribution between the two sides.

The data for Group VI are collected in the following table:<sup>1</sup>

TABLE VII. *Group Six. Position of Operculum. Locality: Bay of Naples.*

Name and Date.	No.	Operc. Right.	Operc. Left.	Per cent Right.	Per cent Left.
<i>Ditrupa subulata</i> ..... 1903/I/10.	4	0	4	0	100
<i>Spirorbis Pagenstecheri</i> ..... 1903/I to V.	11	11	0	100	0
<i>Pileolaria</i> sp. (?) ..... 1903/III/2.	1	0	1	0	100
<i>Pomatoceros triquetroides</i> ..... 1903/I/25, IV/3, IV/5.	22	0	22	0	100
<i>Vermilia multivaricosa</i> ..... 1903/I/16, III/5.	11	6	5	55	45

*Discussion of the Evidence from Group VI.* In *Spirorbis Pagenstecheri* and *Pileolaria* sp. the position of the operculum

<sup>1</sup>Former observations on the position of the operculum in this group are those of Caullery and Mesnil ('96), who state that dextrally coiled *Spirorbis*-like Serpulids always have the operculum on the right side (example—*Spirorbis Pagenstecheri*) while sinistrally coiled ones have it on the left side (example—*Pileolaria* sp. [?]). de St. Joseph ('98) describes the operculum of *Ditrupa subulata*, Desh., as a structure of the left side. de St. Joseph ('94) for himself and also for Grube describes *Pomatoceros triquetroides* as always left-handed.

bears a direct relation to the direction of the coil of the tube. Caullery and Mesnil ('96) have shown that the operculum of *Spirorbis* and its relatives is always located on the side next to the concave surface of the coil, *i. e.*, on the right hand side in dextral tubes and on the left-hand side in sinistral ones. Whether or not any such relation can be made out in other members of Group VI it is not possible to say. In *Ditrupa* there is a slight curvature of a definite form in the tube but the relation of the body within the tube has not been made out definitely enough to determine the significance of the constancy of position of the operculum. In *Pomatoceros triquetroides* there is a definitely fixed left-handedness though the tube is irregularly coiled, and in *Vermilia multivaricosa* there is an almost equal distribution between the two sides, the tube being again irregularly coiled.

A discussion of the factors controlling the determination of the position of the opercula must be left until the ontogenetic and regenerative development of these organs have been studied.

#### 4. Exceptional Degrees of Development in General and One Case of a Supernumerary Operculum.

The two opercula in Groups IV and V in the vast majority of cases consist of a fairly typical functional and a fairly typical rudimentary operculum. There are, however, exceptions to this statement, as has already been indicated above. The main exceptions are due to the partial further development of what probably would otherwise correspond with the rudimentary operculum, either with or without the loss of the functional operculum. There thus arise either one functional operculum and one partly developed functional or a missing operculum and one partly developed one. In other individuals both opercula were found to be rudimentary or one rudimentary and one partly developed one were present. The discussion of these cases must be reserved until we come to the experimental part of the paper.

One case of a supernumerary operculum was found and this is interesting in connection with the problem of the regulation of the opercular development. The accompanying figure (Fig. 9) gives the relations of the opercula. On the left-hand side there is a rudimentary operculum of the typical form in the usual position. On the right-hand side in a corresponding position is a typical

functional operculum, but in addition to it there is an added rudimentary operculum with its point of attachment posterior to that of the functional. This added rudimentary operculum agrees in all respects with the one on the opposite side, so that we have two rudimentary opercula and one functional one. The specimen indicates that the influence which determines the development of a functional or a rudimentary operculum is not always a bilaterally differentiated one. A more complete discussion must be reserved until the experimental data have been given.

## 2. *Development of Opercula.*

### 1. *Ontogenetic Development.*

*a. Introduction.* In a paper, entitled "A Case of Compensatory Regulation in the Regeneration of Hydroides Dianthus," I

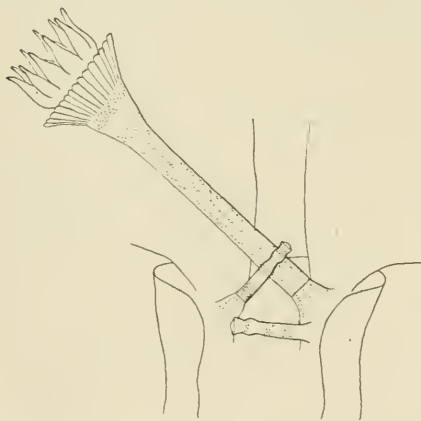

FIG. 9.

Hydroides dianthus with three opercula, two rudimentary and one functional. Note that one of the rudimentary opercula is attached near the base of the functional one ( $\times 15$ ).

described some experiments showing that when the functional operculum of this Serpulid is removed the rudimentary operculum on the opposite side develops into a new functional operculum similar to the old one while in place of the old functional stalk a new rudimentary bud develops. In the discussion of this and similar experiments it was stated that a knowledge of the ontogenetic development of the organ is highly desirable before we can be in a position to discuss the data in their full relations. With this object in view the writer

undertook to raise the larva up to the stage where both opercula have attained their normal adult development.

In attempting a provisional explanation of the compensatory regulation of the opercula it was stated in the above paper that there may be a restraining influence exerted by the fully developed

operculum upon the rudimentary one which prevents the latter from attaining its full development. The removal of the functional operculum removes the restraining influence and the rudimentary continues its development. The new functional operculum in turn restricts the new bud developing in place of the old functional operculum and holds it at the rudimentary stage. The plausibility of this explanation is increased if it is found that in the ontogenetic development one operculum develops before the other, and therefore can hold the latter in check in the manner before indicated. With this object in view the investigation of the ontogenetic development was undertaken.

*b. Historical Review.* The first recorded observations on the development of the branchial apparatus in Serpulids which I have been able to find are those of Milne-Edwards ('45), on the development of the young Protula. He saw the larvæ attach themselves to solid objects at the bottom and sides of his dish. Here they secreted a cylindrical tube which at first was open at both ends and shorter than the length of the larva. At about the same time two lobes were differentiated at the anterior end of the larva, one on each side of the median line. At a slightly later period he thought he saw digitations of these lobes and he took them to be the beginnings of the branchiæ.

Pagenstecher ('63) gives an account of the development of the branchiæ and operculum in Spirorbis. He states that the first traces of the branchiæ are exhibited in the form of three knobs upon each of the two head lobes. The operculum is not differentiated until a later time when there is formed "der Fortsatz welcher ihn tragen soll und der von den Tentakeln durch eine Runzelung oder seichte Kerbung der Oberfläche ausgezeichnet war." Judging by Pagenstecher's figure there is very little difference at the above-mentioned stage between the so-called opercular outgrowth and the other branchiæ. The figure gives two branchiæ on one side and two plus the opercular outgrowth on the other.

Fritz Müller ('64) noticed on the side of a glass vessel which he had on his study table a young Serpulid with three pairs of branchiæ, and which he took to be a member of the Protula group because of the absence of an operculum. However, a short time later he noticed that one of the branchiæ had an opercular enlargement at its end though it still retained its branchial pinnules. Still later the branchial pinnules disappeared also and he had a Serpulid with the typical genus-Serpulatype of operculum, which had developed by a modification of a branchia. In the meantime a new pair of branchiæ had been added to the oral crown making three branchiæ plus one operculum on one side and four branchiæ on the other. This is the only recorded observation of the transformation of a branchia into an operculum.

In 1866 Agassiz described the development of branchiæ and operculum in *Spirorbis spirillum*, Gould (not Lamarck), and made out an alternate appearance of the tentacles (branchiæ). "The first tentacle appears on the right, next comes the corresponding tentacle on the left and only later the rudiment of the odd opercular tentacle (on the right side)." The rudiment of the operculum, though at first somewhat resembling that of the tentacles, shows a difference from the start. Claparede and Mecznikow ('69), on the contrary, make out a *paired mode* of formation of the branchiæ in other species of *Spirorbis*. Willemoes-Suhm ('70) speaks again of an alternate mode in *Spirorbis*.

Giard ('76b) raised the larvæ of *Salmacina Dysteri*. He found two lateral head lobes each of which soon showed a threefold division. These divisions elongated to form the first three pairs of branchiæ. On each side there were two dorsal and one ventral branchia, the latter, however, dividing into two on the fifth day, so that there were then present eight branchial trunks, four on each side. The first pinnule appeared on the eighth day on the upper third of the external dorsal branchia. This is the only notice of pinnule formation I have found.

In *Manayunkia*, a fresh water Serpulid, Leidy ('83), describes the head lobes as showing the branchial digitations from the first trace of formation of the former.

Salensky ('83) likewise states for *Pileolaria* sp. that four branchiæ and the operculum appear at the same time from a median dorsal plate. The opercular "anlage" is from the beginning three to four times as large as the branchial "anlagen." In Salensky's words: "On voit d'après cette description, que, chez *Pileolaria* la formation des branchies et de l'opercule s'opère en même temps, et non comme Agassiz et Pagenstecher le montrent pour *Spirorbis spirillum*."

Meyer ('88) describes the development of the branchiæ in *Eupomatus* (= *Hydroides*). He makes out the appearance of the two head lobes from each of which the three processes representing the first three branchiæ sprout out. The development was not carried further than this. This method of formation agrees also with that described by Roule ('85) for the larvæ of *Dasychone*.

From the foregoing notes it is evident that further observations on the early development of the branchiæ are necessary in order to clear up our ideas regarding the matter, and when we come to the opercular development we have practically nothing outside of the observations on the highly modified forms *Spirorbis* and *Pileolaria* except the short note of Fritz Müller upon the change of a branchia into an operculum. Regarding the formation of the rudimentary operculum there is nothing at all, and we therefore get very little aid in our study of the correlation between



the two opercula at their first appearance and up to the time when they assume the final adult condition.

The following observations on *H. dianthus* were made at the Cold Spring Harbor Biological Laboratory on Long Island, N. Y., during July, August and September, 1902. The observations on the other species, *H. uncinata* and *H. pectinata*, were made at the Naples Zoölogical Station in the winter of 1902-03. The observations on the method of rearing the larvæ and on their general activities will be given in a separate short note.<sup>1</sup>

*c. Observations.* When the free-swimming larva is about nine days old its body is considerably elongated and shows external signs of segmentation. The apical cilium is long and two very prominent, reddish eyespots are present. (Fig. 10A.) As the movements of the animal become more and more sluggish just before its fixation to a solid object the apical cilium gradually grows smaller until it disappears entirely. At the same time three pairs of setæ are formed, the first pair being especially long and prominent. (Fig. 10B.) Fig. 10C shows a larva, 17 days old, with the tube covering about one-half of the body.<sup>2</sup> Here each of the two lateral head lobes already shows the division into three blunt processes, the forerunners of the branchiæ. These divisions of the head lobe appear very soon after the formation of the head lobe itself but the latter has a short separate existence before the tripartite subdivision appears. The two dorsal processes are more closely connected together than with the third and more ventral one. The relation is more clearly made out in Fig. 10D, where the mutual union of the two dorsal pairs is very evident. The two larvæ (Fig. 10C and Fig. 10D) are of the same age (17 days) and come from the same dish.

In Fig. 10E there are still the same three pairs of processes though the branchial character is more evident than before. This specimen is from the same dish as the others (16 days after fertilization). It is evident from these data that the rate of development of the different larvæ in a single dish varies within wide limits. At the stage represented in Fig. 10E the inner surfaces of the branchiæ are covered with very active cilia. In order

<sup>1</sup>Biological Bulletin, '05, vol. viii.

<sup>2</sup>The tube secreted by the animal is at first a very short cylinder which is quite transparent and covers only a small part of the larva. The ring at first is situated near the anterior end of the body just back of the eyes.

to get at the method in which these primary processes branch later on, I have designated them arbitrarily by the Roman numerals I, II and III. I represents the most dorsal pair, II the middle pair and III the ventral pair, R or L being prefixed to represent right or left when there is any need for distinction between the two sides.

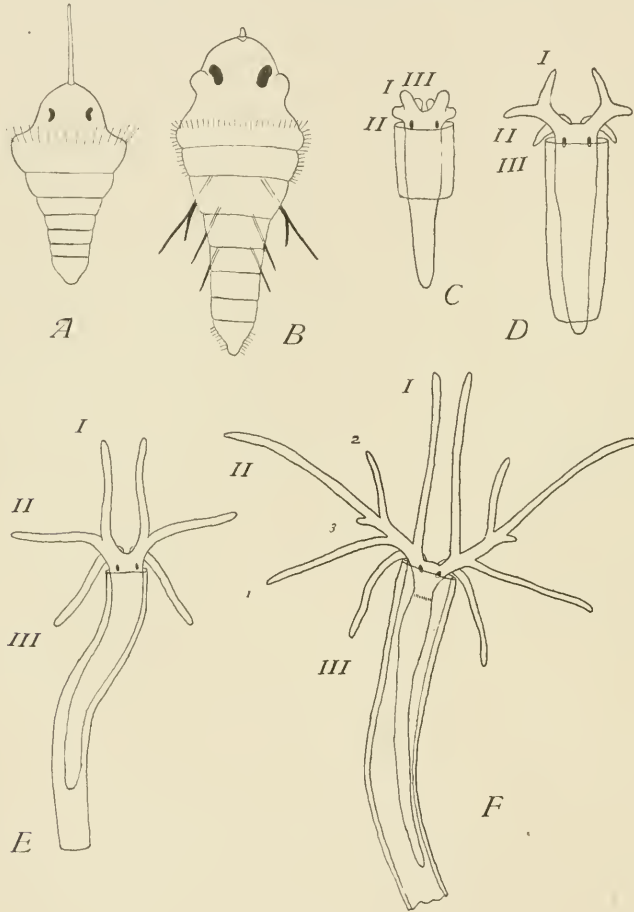

FIG. 10.

*Hydrisoides dianthus*. Larvæ. Stages of transformation from free-swimming to sedentary life. Dorsal views. *A*—Free-swimming larva. Age, 9 days. Shows long apical cilium ( $\times 208$ ). *B*—Swimming but sluggish larva. Age, 9 days. Shows setæ and shortened apical cilium ( $\times 185$ ). *C*—Attached larva ( $\times 90$ ). Age, 17 days. Three pairs of head lobes. Beginning of secretion of tube. *D*—Age, 17 days ( $\times 90$ ). *E*—Age, 16 days ( $\times 85$ ). *F*—Age, 17 days. Second of original three pairs of branchiæ shows secondary branches ( $\times 70$ ).

In Fig. 10F, also 17 days after fertilization, we find a stage considerably more advanced in which each of the middle branchiæ has already sent out three branches, which may be labeled according to age, II—1, II—2 and II—3. Of these it will be seen that II—1 very early takes on the character of one of the main branchial trunks, so that we thus get a stage with four pairs of branchiæ. II—2 and II—3 retain the characters of pinules of the Branchia II. Neither I nor III has any branches at this stage.

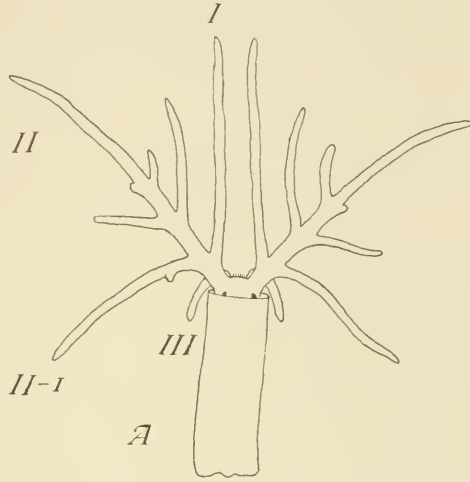

Fig. 11A shows a later stage taken from the same dish at the same time (17 days). Here we still have no branches of I and III. Branchia II has five branches and the first branch of L-II (L-II—1) a branchlet of its own (L-II—1—1) just appearing as a very small knob. It is very evident that Branchia II is rapidly outgrowing I and III in strength.

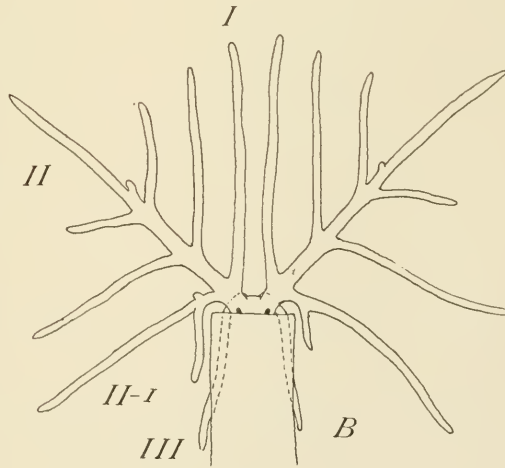

FIG. 11.

Hydris dianthus. Dorsal views. A—Age, 17 days ( $\times 47$ ).  
B—Age, 19 days ( $\times 62$ ).

Fig. 11B (19 days old) gives a still older stage. Branchia I on each side has not increased much in size and is hardly larger than

the older branches of II. L-II—1 has two branchlets (= pinnules) and R-II—1 has one branchlet. Branchia II on each side now shows the beginning of the sixth branchlet or pinnule. Branchia III also has not increased much in size.

In Fig. 12 (23 days old) Branch II—1 with its six pinnules has very evidently taken its place as a prominent part of the branchial

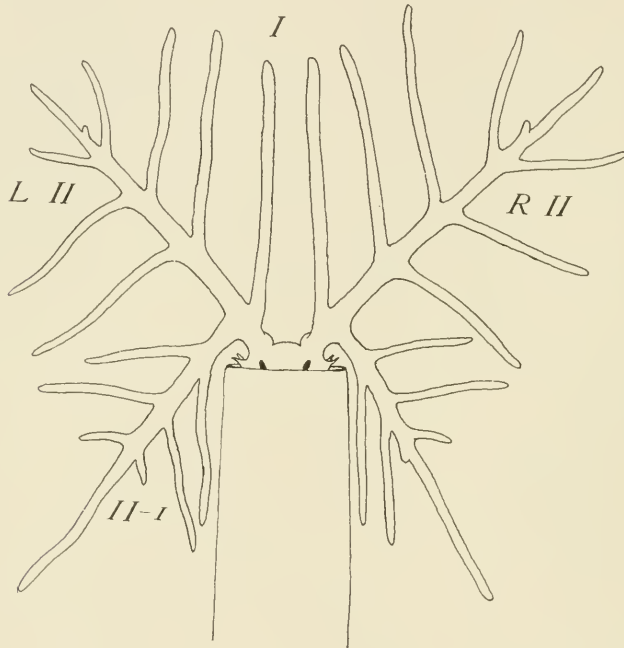

FIG. 12.

*Hydroides dianthus*. Age, 23 days ( $\times 75$ ). The first secondary branch of Branch II has assumed the character of an independent main branch with branchlets of its own. The original third pair of branches is not shown.

apparatus. Branchia II has now added its eighth pinnule. Branchiæ I and III are still unbranched and have increased comparatively little in size.

In Fig. 13 (23 days old), in which only the right side is represented as both sides are essentially similar, Branchia I for the first time shows a trace of branching, seven little branchlets (pinnules) appearing simultaneously. Branchia II has added one new branchlet making nine in all counting Branchia II—1 as the first

one. Branchia II—1 has eight pinnules. The character of Branchia III was not made out.

The operculum was seen for the first time six days later at the stage shown in Fig. 15. Fig. 14, taken five days later still (34 days old), shows an earlier stage of the operculum. Here it appears as a rounded knob on the end of Branchia L-II.

This branchia has at this time nine branchlets counting the one (II—1) which has assumed the character of a main branch. The eight represented as pinnules are II—2 to II—9. The knob at the end of the branchia is conical in form with the base of the cone free and the apex attached to the stalk. The corresponding branchia on the right side (R-II) has likewise at this stage nine branchlets counting the independent one (II—1) or eight dependent ones (pinnules) II—2 to II—9 without this, but there is no modification at the tip of the main stalk as occurs on the left side.

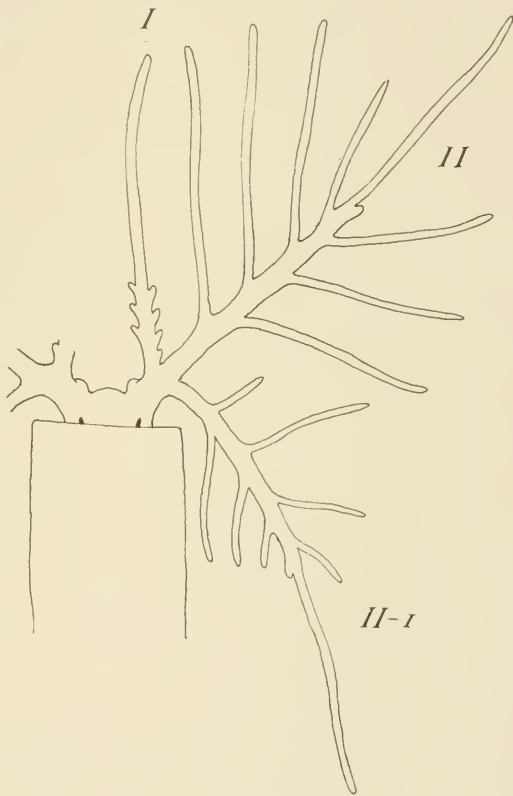

FIG. 13.

Hydroides dianthus. Age, 23 days. Dorsal view ( $\times 75$ ). Original third pair is not shown. First pair shows beginnings of secondary branches.

In Fig. 15 the opercular character of the knob on L-II is very evident. The cup of the operculum has a notched edge with eleven serrations and resembles in its character the *Serpula* type and not the *Hydroides* type. The eight dependent (II—2 to II—9) and one independent branch are very prominently developed

and evidently all of them retain their respiratory character. The corresponding branchia (R-II) on the right side has branchlets similar to those of the branchia (L-II) on the left side though it shows no opercular modifications. It is similar to the latter and different from all the other branchiæ in one essential respect. While I, II—1 and III show buds of new developing pinnules its pinnules (*i. e.*, the eight dependent ones II—2 to II—9) are all

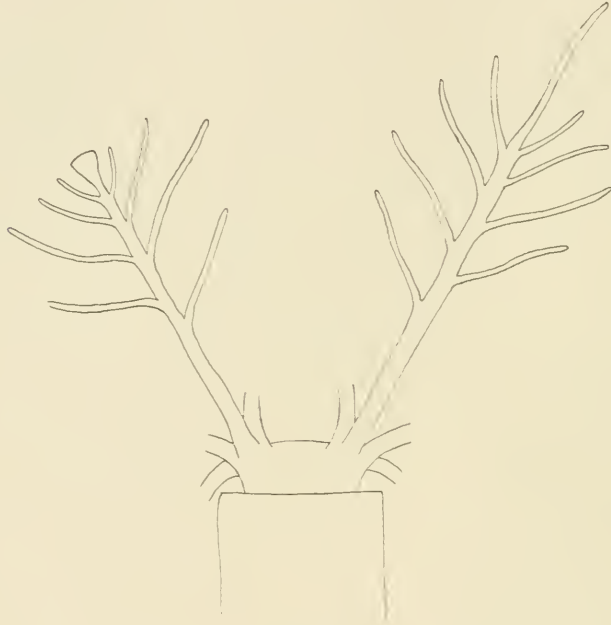

FIG. 14.

*Hydroides dianthus*. Age, 34 days. The next to the dorsal branchia on each side. The left one shows the beginning of the knob of the functional operculum. The right one later drops off and the rudimentary operculum regenerates from the remaining stump.

well grown, indicating, no doubt, that the organ has reached its limit of development as a branchia.

With the beginning of the opercular differentiation Branchia I enters on a new period. It increases in size and new branchlets (pinnules) sprout out in rapid succession, the first ones appearing simultaneously. Thus in Fig. 15, I already has thirteen well formed pinnules with several buds crowded into a zone at the base of the terminal filament. Branchia II—1 has likewise been

increasing in size and now has 12 pinnules plus a thirteenth bud on each side. Branchia III is also branched but the character of its pinnules is not given in the figure in order that complication may be avoided. This pair of branchiæ is directed away from the observer toward the ventral side of the animal. At all these stages the Branchiæ L-II and R-II both retain their flexible and branchia-like character in all respects except for the terminal enlargement in L-II.

In Fig. 16 the pinnules of L-II have disappeared, leaving a cup-like operculum with a serrated edge on the end of a long, slender, flexible but bare stalk. The corresponding branchia on the other side (R-II) has dropped off, leaving only a small round knob at the place of its former attachment. The other branchiæ, I, II—I and III, all are keeping on with their branchial development by continually adding new pinnules to the old ones. We thus have three pairs of branchiæ at this stage with a functional operculum of the *Serpula* type on the left side and a rudimentary operculum on the right side. No young *Serpulids* were observed that showed an exception to this order of appearance of the opercula. Numerous observations were made

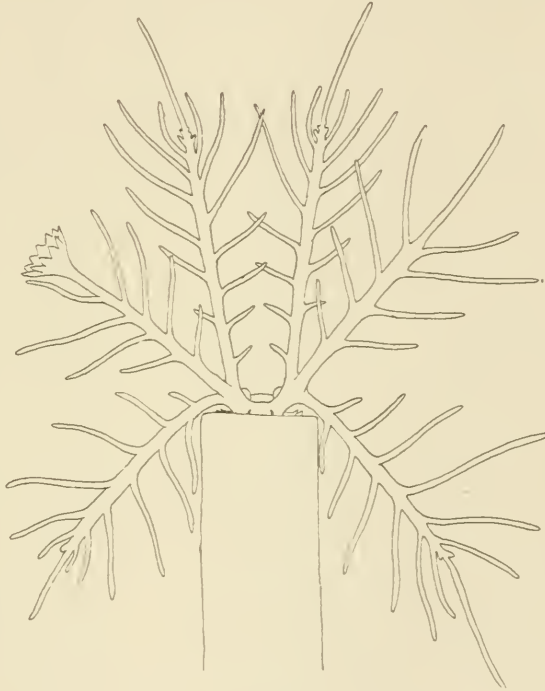

FIG. 15.

*Hydroides dianthus*. Age, 28 days. Shows the three most dorsal pairs of branchiæ. The ventral pair directed away from observer is not shown. The opercular knob of the left side is notched and its stalk still retains the respiratory pinnules. The next to the dorsal branchia of the right side has eight pinnules but differs from other branchiæ, except the opercular one, in the absence of new pinnule buds.

upon specimens before a count was undertaken. In this count twenty individuals were noted. All without exception, the former as well as the latter, showed the functional operculum appearing on the left side.

Fig. 17A shows the rudimentary operculum at a slightly later stage in which it has more definitely assumed its typical condition.

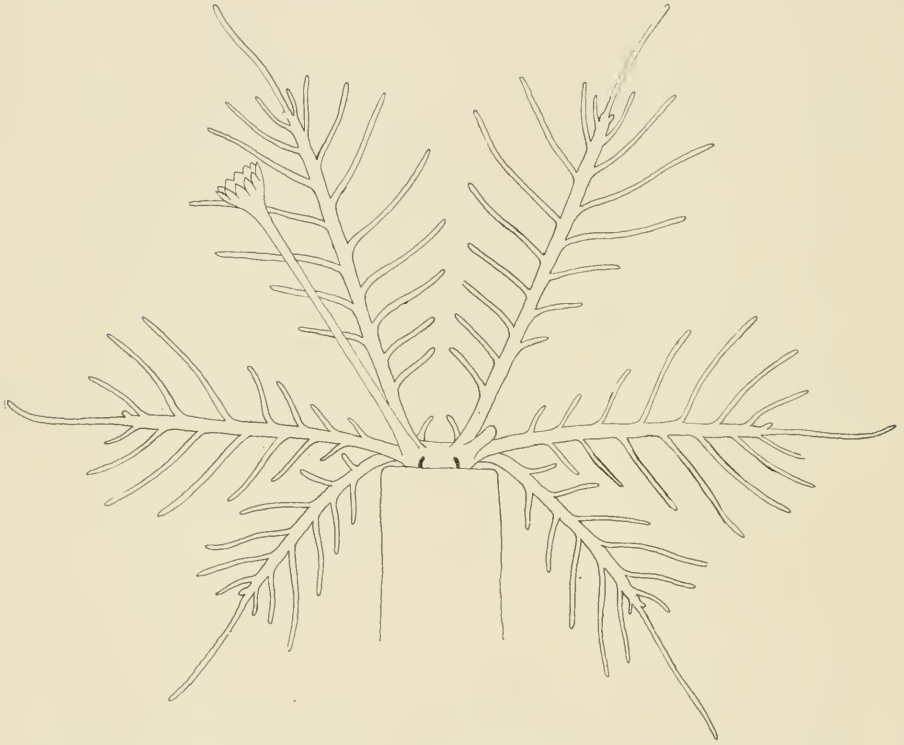

FIG. 16.

*Hydroides dianthus*. Age, 34 days. Dorsal view ( $\times 38$ ). On left side is functional operculum of *Serpula* type with naked stalk and cup with one row of serrations. On right side is rudimentary bud developed from the base of the cast-off second branchia of that side. The three pairs of typical branchiae also are shown.

The condition at this time resembles very closely that of the adult *Serpula*, as the functional operculum as shown in Fig. 16 is without doubt of the *Serpula* type. The further changes were not followed in *H. dianthus*, the species at Cold Spring Harbor, but were made out in the two Naples species, *H. pectinata* and *H. uncinata*.



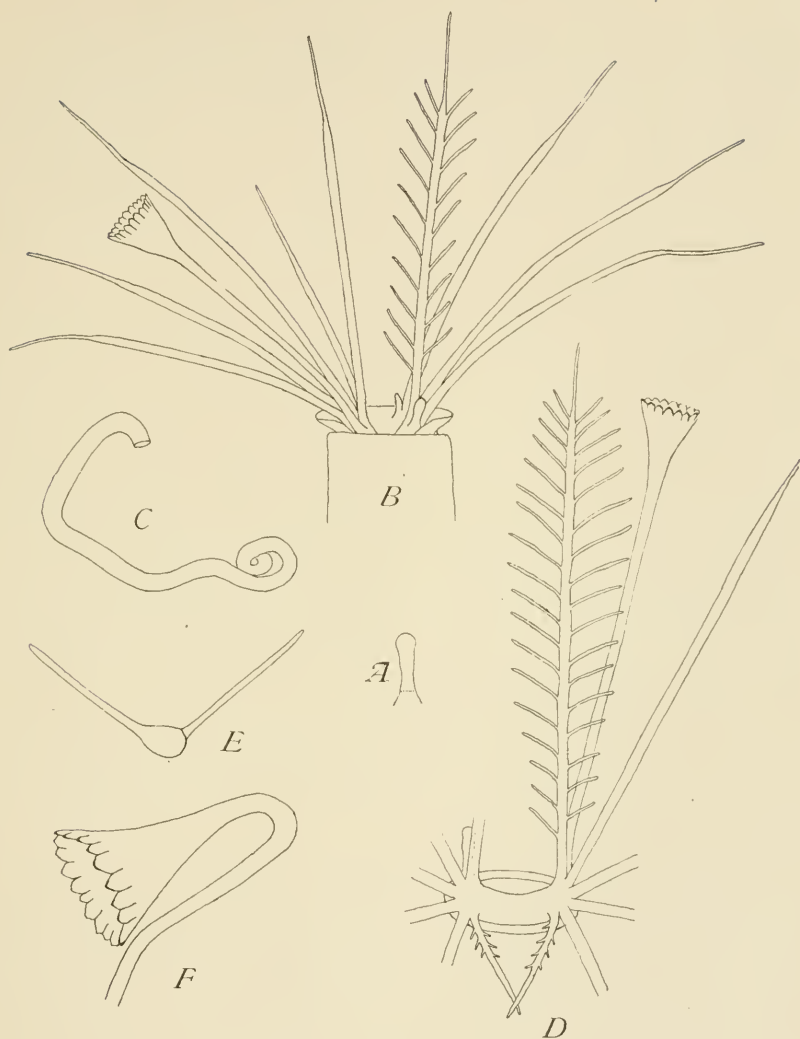

FIG. 17.

*A*—*H.* dianthus. Age, 34 days. Primary rudimentary operculum, right side ( $\times 50$ ). *B*—*H.* pectinata. Age, 45 days. Dorsal view. Functional operculum of *Serpula* type on left. Rudimentary operculum on right. Pinnules are shown in only one branchia, the other branchiæ being essentially similar to this one. *C*—Tube of *H.* pectinata. Age, 45 days ( $\times 6$ ). *D*—*Hydroides uncinata*. Age, 46 days. Ventral view. Shows *Serpula* type of functional operculum on left side and rudimentary operculum on right. *E*—Diagram of cross-section of a branchia of *H.* uncinata showing method of attachment of pinnules. *F*—*H.* uncinata. Age, 179 days or nearly six months. Original or Primary functional operculum as appearing after it has dropped off.

Evidently the adult condition with an operculum situated on either the right or the left side and having two rows of processes at its distal end is not fully explained by the Cold Spring Harbor observations.

Only three larvæ out of a great many sets of eggs started at Naples lived through the period of attachment. Two of these were *H. uncinata* and the other *H. pectinata*. These were first carefully observed only after they had developed up to the stage corresponding to Fig. 16 of *H. dianthus*.

In Fig. 17B is represented a specimen of *H. pectinata* with essentially the same characters as those of *H. dianthus* in Fig. 16. The number of branchiæ has, however, meantime increased and there are here besides the opercula five branchiæ on the left side and four plus the bud of a fifth on the right side. The functional operculum has the essential characters of the *Serpula* type (see above). The new branchiæ are being added on the ventral edge of each of the branchial ridges. Both opercula have moved down from the line of the branchiæ and the gap left in the line by their absence is being closed up. The character of the tube at this stage is shown in Fig. 17C. The tube was so extremely irregular in shape, largely because it was detached from the glass frequently in order to facilitate observation.

Practically the same conditions are shown at this time in *H. uncinata* where there are on each side five branchiæ plus the operculum. The opercula here as before have the characters of the *Serpula* type. (Fig. 17D.)

No further changes in the opercula were noticed for a long time. Finally, six months after the fertilization of the ova, the animals were again carefully observed, and it was noticed that the primary functional operculum (left side) had fallen off (Fig. 17F) and in its place a rudimentary one had developed, while the primary rudimentary operculum of the other (right) side had developed into a functional one. (Fig. 18A, B, C.) The two specimens of *H. uncinata* retained their simple *Serpula*-like operculum longer than did *H. pectinata*.

Returning to the specimen of *H. pectinata* as it was found after the reversal of the opercula we find all the adult characters except the full number of branchiæ. The branchiæ increase in number by additions along the ventral edge of each branchial ridge. In specimens at this stage there are beside the opercula seven branchiæ

plus a very small bud on the left side and six branchiæ plus a large bud on the right. The functional operculum has a basal funnel-shaped cup with a serrated edge. From the upper flat end of this cup there projects a new secondary cup, the individual serrations of which reach nearly to the base and are strongly toothed.

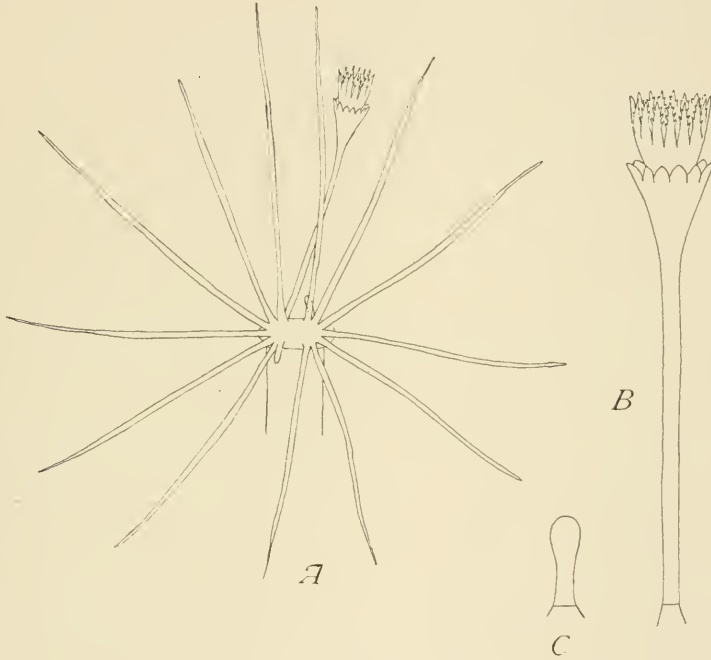

FIG. 18.

*Hydroides pectinata*. Age, 181 days or 6 months. *A*—Ventral (somewhat inclined) view, showing position of secondary functional and rudimentary opercula. Pinnules of branchiæ are not shown in the figure ( $\times 16$ ). *B*—Secondary functional operculum (adult *Hydroides* type with two rows of processes) ( $\times 32$ ). *C*—Rudimentary operculum ( $\times 32$ ).

*d. Summary of Data and Discussion.* The above results concerning the ontogenetic development of the opercula may be summarized as follows:

At the stage with four pairs of branchiæ the next to the dorsal one on each side stops its development when it has eight long slender pinnules. The two branchiæ of the third pair, counting from the dorsal side, arise originally as branches which resemble in all respects the ordinary pinnules, but instead of retaining their

dependent condition increase in strength, develop secondary branches of their own and soon take their place as independent branchiæ coequal with the three primary pairs. After reaching its limit of growth as a branchia the next to the dorsalmost branchia on the *left side* starts a new differentiation at its end, developing a knob which rapidly increases in size and soon assumes the shape of an inverted cone. Along the edge of the upturned base notches appear so that the whole knob has the general character of the opercular cup of members of the genus *Serpula*. All this time, however, the stalk has retained its eight branchial filaments and the corresponding branchia on the other side has remained unchanged. This stage corresponds in general with the adult of *Filograna* or rather with *Apomatus* except that only one operculum is present. The branchial filaments of the stalk, however, soon disappear. Whether they drop off or are resorbed was not made out but the former supposition is the more probable one, as they were still very long a short time before they had entirely disappeared; or, in other words, no intermediate stages of resorption were seen. Almost coincidentally with the disappearance of these pinnules the next to the dorsal branchia of the right side drops off, the region of the break being near the base. From this broken stump a bud develops which in a few days has reached its limit of development for the time being. This bud, which *remains as the primary rudimentary operculum* for several months, is a *regenerated structure, a true case of physiological heteromorphosis*. Furthermore, it is restricted in its development by some forces acting from without its own substance. At this stage the opercula remain for a considerable time (several months) with no further change, although at the same time the animal is increasing in size, is building up its tube and new branchiæ are being added on the ventral edge of each of the branchial ridges. In its essential characters this stage is equivalent to that of adult members of the genus *Serpula* with the functional operculum on the left side.

After this long period of no opercular change the primary functional operculum drops off, the stalk breaking near its base. Immediately the primary rudimentary operculum on the right side, no longer restricted by outside forces, starts its further development and becomes a functional opercular organ. However, it does not develop into an operculum of the simple type like the pri-

mary functional one. Instead it takes on the characters of the adult Hydroides operculum with two rows of serrations. Beside the inverted cone with serrations around its upper edge there is an additional circlet of pointed and often hooked processes, which constitute the most important character of the Hydroides group as distinguished from the Serpula group. At the same time the broken stump on the left side has started to develop a knob of embryonic tissue which grows only up to the stage represented by the rudimentary operculum of the adult and is in its turn restricted in its further development by some force most likely similar to the one which in the first place restricted the original primary rudimentary operculum. There are, therefore, at this time a secondary functional operculum on the right side and a secondary rudimentary operculum on the left side. These have the essential characters of the opercula of adult specimens of Hydroides. However, one point of difference is evident in specimens taken at random from the sea. It is found that approximately the same number have the operculum on the left side as on the right though there is uniformly a slight advantage in favor of the right-handed ones (57 per cent right-handed to 43 per cent left-handed in *H. dianthus*), while all the larvæ appeared first as left-handed ones and later by reversal changed to right-handed ones. How does this change occur? Either we must suppose that the similarity in character of all the larvæ was accidental or that the reversal takes place in nature during the life of the individual more than the one time described for the young animal. The first supposition seems improbable because the larvæ came from a great many different individuals, and moreover the order of appearance was found to be the same in the two Naples species (*H. uncinata* and *H. pectinata*). We are, therefore, forced to assume a further reversal as taking place in nature. This reversal may be a purely physiological one, induced by the normal activities of the animal, like the first reversal already described, or may be induced by some injury to the functional operculum of the character which was found to cause such a reversal in my experiments. (See below, p. 55 *ffl.*) However, unfortunately, there is no experimental evidence to show that physiological reversal takes place in nature after the first time already described. As is mentioned elsewhere (p. 65) in this paper the experiments undertaken to determine whether worms

kept in dishes<sup>6</sup> in the laboratory exhibited physiological reversal were negative, although the time was in all cases too short to constitute a good test. There was no change in any case unless the functional operculum was injured. However, the very near equality between right and left-handed individuals seems to preclude the possibility of all reversal being due to injury of the functional operculum. And we have beside the analogous case of physiological reversal in the young animals as has been emphasized before.

## 2. Regeneratory Development.

*a. Introduction.* The nature of the opercular modifications among the Serpulids has now been outlined in the discussion of the comparative anatomy and their *origin* within the individual life history has been traced in the genus *Hydroides*. There now remains an attempt at an *experimental analysis* of the factors involved in the development and maintenance of the adult characters. Partly because of the imperfection of the method and partly because it is not desirable to dissect the data too minutely while presenting them, the latter will be given in the descriptive portion of this section as parts of individual experiments without perfect regard to logical development of the analysis of the factors involved. The latter will be attempted more fully in the general discussions to follow the descriptive portions.

In a former paper a preliminary report of some of my experimental results on compensatory regulation in the regeneration of *Hydroides dianthus* was given. Since that time a more detailed series of experiments has been undertaken along the same lines and the work has been extended to other species of the family. Two distinct problems have come up. In the first place is the study of the factors involved in the compensatory regulation of the opercula which, as stated above, is the main object of the present paper. In the second place a comparison of the regeneratory development of the opercula with the ontogenetic and with the probable phylogenetic development brings up an extremely interesting discussion with important bearings on the recapitulation theory.

The great majority of the experiments were performed on *H. dianthus* and this form will be discussed first. Then will follow the other members of Group V, namely, *H. uncinata*,

*H. pectinata* and *Serpula vermicularis*, then a member of Group IV, *Apomatus ampullifera*, and finally the members of Group VI, *Ditrupa subulata*, *Spirorbis Pagenstecheri*, *Pomatoceros triquetroides* and *Vermilia multivaricosa*. The adult condition of the opercula which has already been described in detail in the anatomical portion of the paper will be again briefly noted, as it must serve as the basis of our experiments. The experiments will then be described in turn, and finally the results will be discussed.

*b. Unoperated Condition of the Opercula in Hydroides Dianthus.* The character of the adult opercula has already been given on p. 21 *ffl.* and is also shown in Fig. 5E, F. A repetition of these data is therefore unnecessary.

In all the experiments about to be described the animal was first removed from its tube and placed in a dish of sea-water, the desired operation was performed under a dissecting microscope and the animal was kept in its individual dish either with running or standing water, in the latter case the water being changed once or twice a day as required. The running water was not found as favorable as the standing because of the collection of a fine deposit on the animals notwithstanding the greatest care exercised. The dishes with standing water were found very favorable if provided with a glass cover to keep out the dust. The observations were in most cases made on the living animals.

*c. Operations on Functional Operculum.* The results may best be arranged around a description of the effect of a cross cut through the stalk three-fourths of the distance from the base to the beginning of the terminal expansion. The stump of the functional stalk remains attached to the animal for two or three days as a rule or even longer in some cases. It then breaks off from the body, separating by a clean division at the basal suture or "breaking joint" described above (pp. 21-23). On the distal end of the small stump still remaining attached to the animal a small bud now appears and gradually increases in size until it reaches the dimensions and character of the former rudimentary operculum of the opposite side. At this point it stops and proceeds no further. In order to understand the result it is necessary to look away from the immediate vicinity of the operated organ and to note the change going on in a corresponding position on the other side of the animal. Even before the attached stump of the

operated functional operculum has fallen off the rudimentary operculum has started to enlarge and processes appear at its distal end. Gradually the structure increases in size and assumes

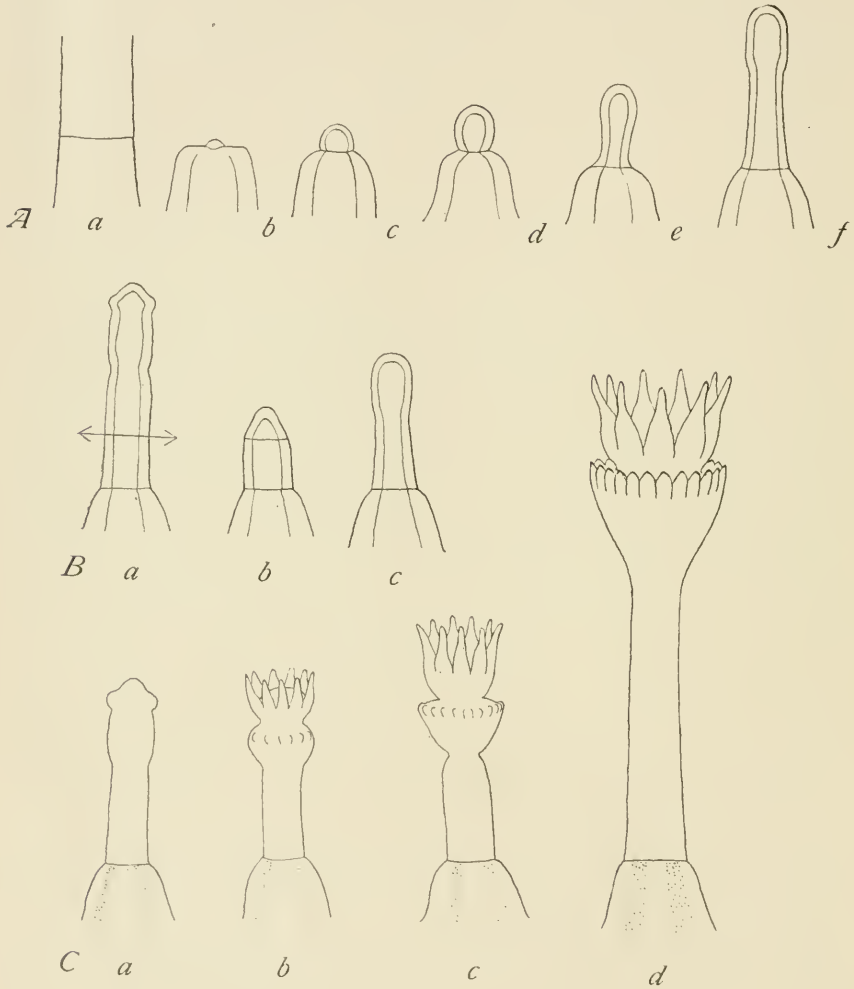

FIG. 19.

*Hydroides dianthus*. *A, a-f*—Stages in the development of a rudimentary operculum from the stump of an old functional one ( $\times 54$ ). *B, a-e*—Stages in the regeneration of a rudimentary operculum after a cut at the region indicated by the double-headed arrow ( $\times 54$ ). *C, a-d*—Stages in the transformation of the old rudimentary operculum into the new functional after removal of the old functional operculum. The final condition of the functional operculum is shown in Fig. 5F.



more and more the character of the former functional operculum. After 15 to 20 days the development is complete and we have a complete reversal of the opercula. The former functional operculum is now the rudimentary and the former rudimentary has become the functional. The resulting arrangement is the exact reciprocal of the former one.

The case just briefly outlined will now be taken up in more detail. Before the stalk of the functional operculum is cut it is almost impossible to pull it off from the animal. The basal suture resists breaking as well as the solid material of the stalk. The hardest kind of a pull that can be given with a pair of forceps is not sufficient to dislodge the organ. Inside of a few days after the operation, however, the opercular stalk as we have seen comes off of its own accord, so that great changes must be assumed to have taken place in the region. The time at which the stalk drops off varies greatly. In one case it had not come off 5 days after the operation and in another after 6 days it was still attached. Very soon after the stalk has dropped off a bud appears at the top of the stump and this steadily increases in size until the typical form of a rudimentary operculum is reached. (Fig. 19 A, a-f.) It seems very probable that the breaking off of the remanent of the stalk is induced by histological changes in the suture region which are attendant upon the beginning of the development of the new bud. Evidence in favor of this view will be given later in another place.

Except in one case no differentiation of tissues took place at the cut end of the functional stalk. In this case there was an expansion on each of the two sides of the stalk near its tip. The stalk did not drop off for 5 days after the operation. The changes are represented in Fig. 20.

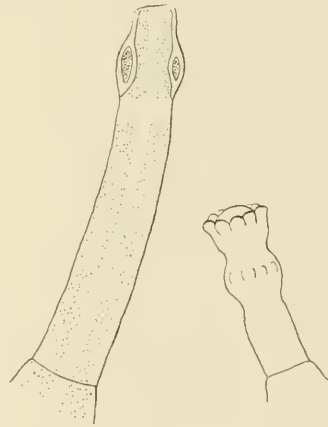

FIG. 20.

Opercula of *Hydroides dianthus*, five days after transverse section of stalk ( $\times 26$ ). Exceptional case. Differentiation at the distal end of a functional stalk which had been cut two-thirds of the distance from the base to the terminal cup. The old rudimentary is also shown.

The changes taking place on the other side of the body are very evident 3 or 4 days after the operation, often before the remnant of the functional stalk has dropped off. This fact that the rudimentary operculum begins to develop even before the functional has dropped off seems to argue against the mere retarding influence of the organ as a mechanical weight, though of course the weight is considerably diminished by the removal of the part of the operculum distal to the cut. The stages through which the rudimentary operculum passes in changing into a functional one are given in the accompanying figures. (Fig. 19c, a-d.) The essential points to be emphasized in this development are: first, *the fact that throughout there is no sign of the appearance of special branchial characters*, and, second, *that the secondary processes of the operculum appear before the primary ones*. The regenerative development, therefore, differs widely from the ontogenetic or probable phylogenetic one as regards these points.

A series of operations was performed on the functional operculum to determine the amount of injury necessary to bring about reversal. The cases overlap slightly but it is found that in general the cutting off of the distal circlet of processes does not induce reversal while cuts through the main enlarged portion of the operculum bring about a reversal of the opercula. In one case the stalk of the injured operculum remained attached though the rudimentary operculum in the meantime had reached a stage equal to three-fourths of the normal functional development. It may be concluded that *a removal of the secondary circlet of processes of the functional operculum does not as a rule cause reversal, while a similar injury below this point to the main portion of the cup or to the stalk of the operculum always brings about such a result*.

*d. Operations on Rudimentary Operculum.* When the rudimentary operculum alone is removed there is no effect upon the functional operculum and a new rudimentary develops in place of the old one which had been cut off. The cut end rounds off, a bud-like mass of new tissue appears there, and the whole, both old and new tissue together, gradually assumes the shape of the old rudimentary operculum. The greater part of the change from the beginning is, however, accomplished by the growth of new tissue and only very little by the change in form of the old. No further development takes place. The result is the same no matter what the level of the cut may be. One of the levels at

which cuts were made in my experiments is shown in the accompanying figure. In none of them did the functional operculum change its character or did any structure other than a rudimentary operculum develop in place of the old rudimentary. (Fig. 19B, a-c.)

*e. Operations on Both Opercula.* When both opercula were cut off it was found that while in some cases there was a reversal, in others two functional opercula were developed, one on each side, while in still others characteristics differing from either of these two combinations were formed. An attempt was made to find the cause of the difference in results and with this object in view cuts were made at different levels. The difference of level in the cuts in the rudimentary operculum could not be easily controlled, but since in the former cases where only the rudimentary operculum was removed there was no specific influence either on the opposite functional operculum or on the new regenerating one, it is supposed that these differences of level have here also no influence upon the character of the result. In every case care was taken to bring the cut well down toward the base of the rudimentary operculum. The different levels on the functional operculum are indicated in Fig. 21. A summary of the results is made in Table VIII.

If we neglect the differences in the levels of the cuts in the rudimentary operculum and divide those of the functional one into

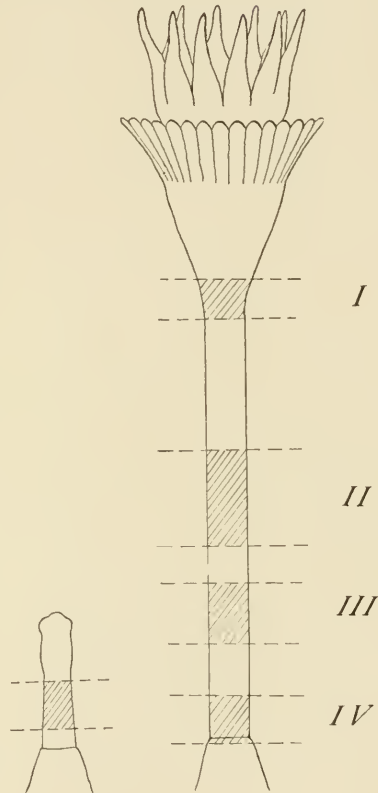

FIG. 21.

*Hydroides dianthus* ( $\times 30$ ). Operations made on both opercula simultaneously. I, II, III, IV represent the regions of functional operculum in which the cuts of the four groups of experiments were made. The shaded portion of the rudimentary operculum between the two dotted lines includes all the cuts on this side.

four groups we get a very interesting correlation between the regions and the corresponding results of the operation. In this way we get four fairly well marked groups. Group I consists of accurately located cases near the distal end of the stalk where it expands into the cup. Group II has the earlier cases located from description alone, in most cases stating that the "functional stalk was cut near its middle." Group III has accurately determined cases located about one-fifth of the length of the opercular stalk from the basal suture. Finally, Group IV contains the cuts made just distal to the basal suture. (Fig. 21.)

TABLE VIII. *Hydroides dianthus*. Both Opercula Removed.

	$F_1 = F_2$	$F_1 = R_2$	$F_1 = F_2$	$F_1 = S$	$F_1 = r'$
	$R_1 = R_2$	$R_1 = F_2$	$R_1 = F_2$	$R_1 = F_2$	$R_1 = r''$
Group I.....	0	3	0	0	0
Group II.....	1	1	3	1	1
Group III.....	0	1	4	0	0
Group IV.....	0	5	0	0	0

$F_1$  = Original functional operculum.

$R_1$  = Original rudimentary operculum.

$F_2$  = Resultant functional operculum.

$R_2$  = Resultant rudimentary operculum.

S = Functional stalk remains attached.

$r', r''$  = Small undifferentiated buds of new tissue.

In Group I the three valid cases (see Table VIII) all showed a reversal of the opercula, the old functional becoming the new rudimentary and the old rudimentary becoming the new functional.

In Group II where the region of the cut was not so accurately located the results are scattering. Seven of the cases give results valid for our purpose. Of these three developed two functional opercula, one showed a reversal similar to that of Group I, one showed the development of a new functional in place of the old and a new rudimentary in place of the old rudimentary, in one the functional stalk did not become detached and the old rudimentary developed into a functional, and in still another case there were rudimentary buds on both sides, neither of which reached a stage beyond a rounded knob and were, therefore, not developed even up to the rudimentary stage proper.

In Group III, consisting of accurately determined levels, four of the five cases showing valid results developed two functional opercula, the fifth one showed a reversal of the opercula.

In Group IV, also consisting of accurately determined levels, five cases showed a clear result and all of them had a reversal of the opercula.

The result is a peculiar one in that *the most distal and the most proximal groups agree in giving rise to a reversal of the opercula, while the intermediate two groups give rise in a majority of the cases to two functional opercula.*

An attempt at an explanation is hazardous and can be little more than a guess. Such a provisional attempt may, however, be made, for by so doing some light may be thrown on the regulation of the "normal" condition in the animal. An examination of the whole number of cases where both opercula are cut off shows that in all but two the rudimentary operculum after regeneration did not stop at the rudimentary stage but kept on developing until it reached the functional stage. The difference in the results is then due to differences in the regenerative development of the old functional operculum. What factor or factors hold it in the rudimentary stage in some cases, while in others it is allowed to develop into a full-sized functional organ? Two factors are to be considered: first, the influence of the position of the cut upon the initial stages of change in the embryonic tissue in the neighborhood of the basal suture and, second, the possibility of a retarding influence emanating from the new functional operculum which is rapidly developing on the opposite side from the stump of the old rudimentary.

*First Factor.* It has been shown above (p. 58), in the series of experiments with an uninjured rudimentary operculum, that injury to the extreme distal portion of the functional operculum does not lead to the dropping off of the injured organ or to the development of the opposite rudimentary operculum into a functional. Further, from the same series of experiments it is seen that the development of the opposite rudimentary operculum is more easily induced by a terminal injury to the old functional than is the dropping off of the old functional stalk. The latter point is well illustrated by several cases in which the injured stalk remained attached to the animal while the opposite rudimentary had already developed into a full sized new functional. From these data we

may assume that the distal cuts do not affect the embryonic tissue at the basal suture as quickly as do the more proximal cuts and for this reason the tissue will have had only a small start when the opposite rudimentary already has a very considerable one. The latter may then restrict the further development of the bud after the old stalk has fallen off. In Group IV, on the other hand, the cut is so near the embryonic tissue of the suture itself that it may directly injure the cells which are to give rise to the mechanism of a cleaving plane or else leave such short leverage in the distal portion of the stalk as to compel the growing tissue to do all the work in pushing off the useless portion and thus to retard its growth. It is possible also that in some of the cases in Group IV the short portion distal to the suture is not cast off, but that the tissues are re-formed and thus give rise to the growing bud. However, no observations were made on this last point and it is merely put down as a possibility in view of some of the later experiments on *Pomatoceros* (p. 70).

*In the above paragraph an attempt has been made to show how the embryonic tissues at the basal suture in Group I and in Group IV may develop up to the stage of a rudimentary operculum less rapidly than those of Groups II and III.*

*Second Factor.* Admitting this greater development of the bud of the old functional side in Groups II and III than in Groups I and IV, and further assuming the uniform development of the bud of the old rudimentary side in all four groups, we are led to the consideration that if one of the opercula when well developed compels the other to stay in a rudimentary stage such a cause may act in Groups I and IV and not in Groups II and III. *Therefore, in the former cases, the result of the simultaneous operation on both opercula is a reversal of the original condition, while in the latter it is the production of two "functional" opercula.*

*f. Body Cut in Two. Regeneration of Opercula at the Anterior End.* When the body is cut in two in the thoracic region two opercula and groups of branchiæ are regenerated on the two sides of the median line but the opercula instead of being differentiated into a large one and a small one are both of the large functional type. We must assume in this case that since both had an equal start in development the retarding influence of the one upon the other which occurs in other cases did not occur here.

The newly developed opercula were in some cases exact dupli-

cates, the one of the other, but in others one operculum was considerably larger than the other, though both showed the true "functional" characters. The extremes of the different cases are given in the accompanying figure. (Fig. 22.)

The resultant opercula usually differed from the normal functional one in being shorter and stubbier than the latter. It is to be noted that two fully developed opercula of the kind indicated can

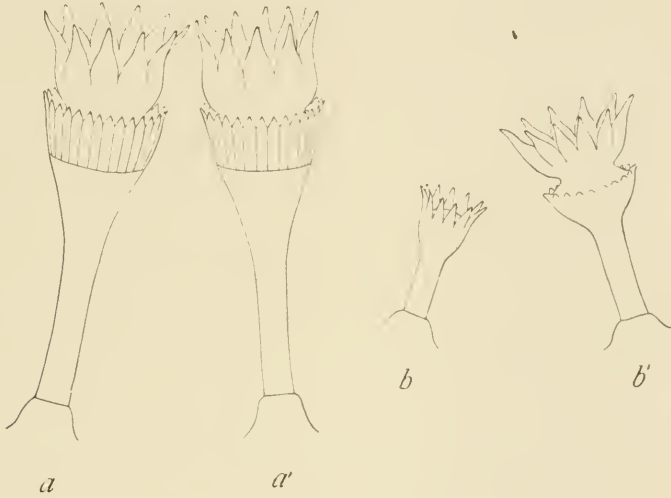

FIG. 22.

*Hydroides dianthus*. Opercula as regenerated at the anterior end of the posterior piece after transverse section in the thoracic region ( $\times 17$ ). Left, case with equal opercula. Right, case with unequal opercula.

be of little value in closing up the opening of the tube as each one stands in the way of the other. The animals in the experiments were, however, not kept in their tubes so that the actions under such circumstances were not observed. It seems that the anterior missing segments were not regenerated in any case. Whether such regeneration would be possible under favorable conditions cannot be said. In my specimens bacteria and infusoria developed on the tender regenerating tissues and the growth was retarded and finally stopped.

The main point as regards the opercula made out in the group of experiments where the body was cut in two in the thoracic region is this: *When the opercular buds have an equal start in development both develop into functional opercula.*

The relation of the developing opercula and branchiæ of each side to the nerve cord of that side is very interesting. This is most noticeable in the regeneration of these organs from a cut near the posterior end of the thorax where the nerve cords are widely separated. In the Serpulidæ it will be remembered the nerve cords do not come together ventrally as in most Annelids but remain widely separated, forming two latero-ventral trunks. The principal blood vessels, however, do not have this arrangement. The branchial circllets, each with its operculum, regenerating from a cut near the posterior end of the thorax, are always widely separated and seem to be located in intimate relation with the nerve trunks of the corresponding sides. This fact agrees very well with the data as made out by Morgan ('02) for the regeneration of the head of the earthworm which showed that the regenerating head always develops in connection with the anterior cut end of the nerve cord. A similar relation has been made out for other forms. A further discussion of this and other cases of nervous control in regeneration is reserved for a future time.

The results of a *transverse cut in the abdominal region* were in every case negative as far as the posterior piece is concerned. Its anterior cut surface in every case healed over and no regeneration took place. The piece lived for a considerable time but did not show any signs of regenerating tissue.

In this connection two other groups of experiments may be described.

The first concerns the regeneration and regulation following the *longitudinal dorso-ventral division of the body* into equal right and left parts.

In this group a dorso-ventral longitudinal cut divided the body into approximately equal right and left halves. Fourteen specimens were operated on in this way and of these several showed traces of the regeneration of knob-like elevations near the anterior end of the cut surface. Two of these showed especially clear structures which correspond very well with young regenerating branchial circllets from the anterior end of a posterior piece after transverse section of the thorax. It is probable that the new structures may be located at a cut end of a nerve cord. In one of the cases the new circllet in question was a considerable distance behind the old branchial circllet. In no case did the animal live long enough to allow of a full development of the new organs.



The effect of the cut upon the old organs is as follows: The rudimentary operculum in several cases showed a slight development though only one advanced to the stage with both rows of opercular processes present. Usually the rudimentary operculum remained unchanged or a slight development of the secondary processes took place. No changes were observed under similar circumstances in the functional operculum.

The second group of experiments concerns the regeneration from a posterior cut surface of a half (right or left) Serpulid. Two of the cases of regeneration at the posterior cut surface after longitudinal dorso-ventral section of the whole organism showed very clearly the character of the new tail bud regenerating there. After transverse section of the whole body in the abdominal region the new tail bud is always very evidently double. In the present experiments, however, where only half of the animal was used the regenerating bud always showed a single tail knob. As the two components of the ventral nerve-cord in Serpulids and Sabellids are widely separated this singleness of structure may be correlated with the presence of only one of these nerve cords at the posterior end when the animal is cut in two longitudinally before the cross cut is made.

*g. Progressive Changes in Opercula.* Progressive changes in the opercula of adult specimens were not observed. Several groups of specimens were kept under observation for varying periods of time but in no case was evidence of such a change noted. It must, however, be stated that the periods were all relatively short, not over a month at most. The indirect arguments in favor of the occurrence of such changes as furnished by specimens in nature with intermediate stages of reversal, etc., are given elsewhere. (p. 33.)

*b. Experiments on Group V.* (See p. 26 for definition.) A series of experiments on *H. uncinata* was undertaken with the object of determining the relative capacity for regeneration at different levels in the body. The most posterior region showing regeneration of branchial and opercular structures was an anterior cut surface located between the next to the last (sixth) and the last (seventh) thoracic segments. Several posterior pieces back of this point lived for a sufficient length of time to allow of regeneration if it were to occur at all, but all these healed up at the cut surface and showed no regeneration of head structures. We

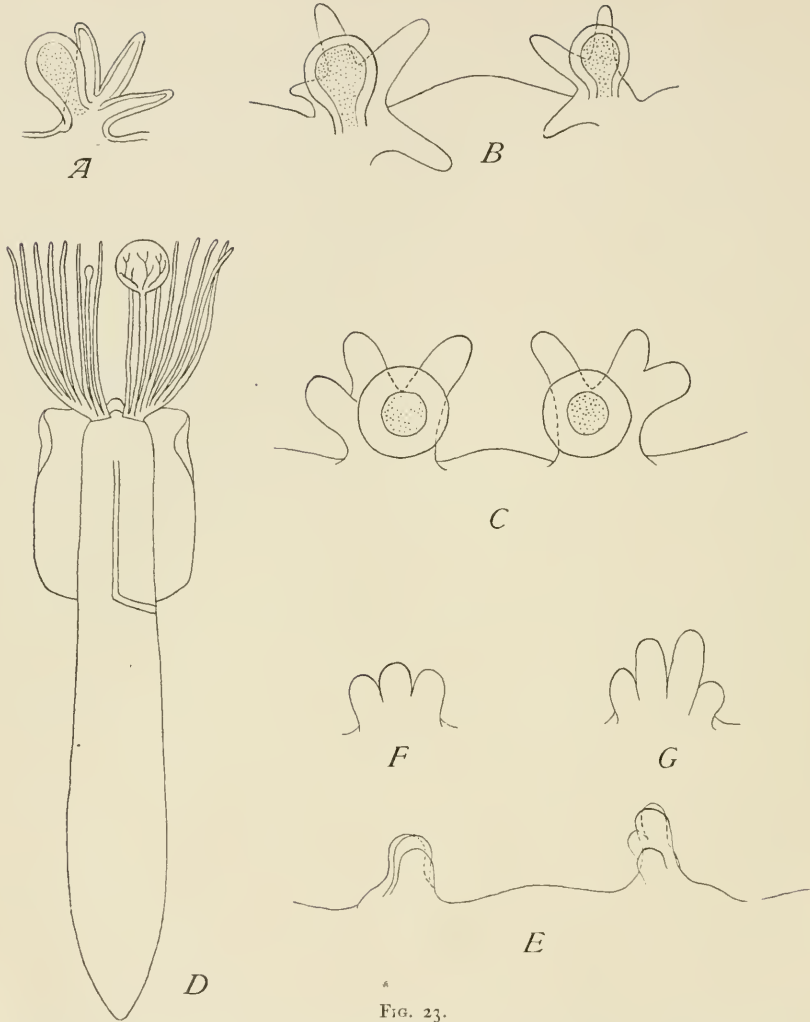

FIG. 23.

*A, B*—*Hydroides uncinata*. Regenerating branchiae and opercula at anterior cut surface after transverse section between fourth and fifth thoracic segments ( $\times 93$ ). *A*—13 days after operation. *B*—14 days after operation. *C*—*H. uncinata*. Regenerating branchiae and opercula at anterior cut surface after transverse section between first and second thoracic segments, 18 days after operation ( $\times 60$ ). *D*—Dorsal view of *Apomatus ampullifera* showing functional and rudimentary opercula ( $\times 5$ ). Pinnules not represented. (See also Fig. 6 *D, E, F*).

*E, F, G*—*Apomatus ampullifera*. Regenerating branchiae and opercula at anterior cut surface after transverse section between the third and fourth thoracic segments, 23 days after operation ( $\times 60$ ). *E*—Dorsal view of both branchial groups. *F*—Left group as viewed from right side. *G*—Right group as viewed from left side.

must, therefore, for lack of positive evidence to the contrary decide that in *H. uncinata* the power to regenerate head structures is found only in the thoracic region and that anterior surfaces of the posterior pieces after transverse section through the abdomen do not possess this power.

The manner in which the regeneration takes place is extremely interesting when compared with the development of the same structures in ontogeny. It was found that in each of the cases at the earliest stages three branchial buds and one opercular bud were present on each side. (Fig. 23A, B, C.) *This corresponds with the number present in the ontogenetic development of Hydroides at the first appearance of the opercula.* A similar relation holds for the regeneration of the branchial circlets of *Apomatus* after a transverse cut in the thoracic region.

A series of experiments was performed on *H. pectinata* to determine whether the cutting of the animal in two by a transverse cut through the second and third segments of the thorax would cause any changes in the opercula remaining at the anterior end. In this series the opercula were not disturbed. The result was not completely satisfactory because most of the specimens died at an early stage but it was found that the cut did not cause the opercula to change. A severe bodily injury, therefore, need not cause a reversal.

Another series was undertaken in the hope of finding the influence of sectioning of the thorax upon the differentiation of the opercula after the functional stalk had been cut at its middle. It was found that the separation of the region of the body back of the fourth thoracic segment from the rest *does not retard* the changes of reversal in the opercula which usually take place after a section of the functional stalk at its middle.

A single specimen of *Serpula vermicularis* was operated on. Both opercula were cut off, the functional one at its middle. The result was a reversal of the former condition. The animal was kept in its dish unobserved for about three months and was then found to have reversed back again to its original condition.

i. *Experiments on Group IV. Apomatus ampullifera.* Two characteristics of the branchiæ and opercula of *Apomatus* need to be taken into account before going on with a description of the experiments. (See also description, p. 26.)

In the first place there are two opercula, one a large spherical body and the other a very small terminal enlargement, each at the end of the branchial stalk occupying the next to the dorsal position in its branchial circlet. This stalk is in each case a typical branchia except for the opercular enlargement and apparently carries on its full respiratory as well as its opercular function. (Fig. 23D.)

In the second place each branchial semicircllet taken as a whole breaks off very readily along a definite line at its base so that all the branchiæ including the opercular one come off together. Thus a very slight irritation is sufficient to cause the animal to throw off the whole branchial apparatus, including the opercula. The fission plane is in a very definite region at the base of the branchial circlet and after coming off the whole branchial crown holds together in one piece because of the union of the branchiæ near their bases. The right and left branchial circlets act independently in the matter since it often happens that only one is cast off. Usually, however, both are thrown off. Such an operation as the removal of the animal from its tube usually brings about this autotomy of the branchiæ. Out of 42 specimens removed from their tubes on November 6, 1902, thirty lost both branchial circlets, 6 lost one of the circlets and only 6 retained the whole branchial crown. For this reason it was not possible to repeat the ordinary operculum reversal experiments on *Apomatus* as after such an operation the branchial circlet was cast off.

After the casting off of the branchial crowns in these cases a regeneration of two functional opercula usually followed, though one was often larger than the other. Probably correlated with the differentiation of a "breaking joint" at the base of the circlet is the fact that the regeneration of the branchial crown does not show only three branchiæ plus the operculum at the first differentiation as in *Hydroides* but at once brings out several branchiæ on each side. One of these may show the opercular differentiation from the start, while in other cases it develops first as a branchia and only later shows the opercular character.

The regeneration at the anterior end of a posterior piece after transverse section through the thoracic region showed a less highly differentiated character of the new organ at the start than when the regeneration took place from the "breaking joint." A great number of operations were made, but the animal proved very

sensitive to the injury and nearly all the individuals died very early. However, the beginning of the process of regeneration was observed in a few cases. In one of these which had been cut through the third thoracic segment there was, 23 days after the operation, a distinct indication of the young branchial circlets at the anterior end of the posterior piece in the form of *three branchial knobs on the left side and four on the right*. (Fig. 23E, F, G.) Of the latter four the ventral one was very small and the next to the dorsal one evidently larger than the others and showing thus early its opercular character. The regenerating tissue appears first as an undifferentiated mound. When differentiation does occur it takes on the form of three or four knobs in each mound, corresponding evidently with those of *Hydroides dianthus* after a similar section and reminding one strongly of the first branchial differentiation in the young of the latter species where, as we have seen, each branchial circlet appears first as three processes, one of which divides at its base, forming four in all. The early differentiation of the opercular knob after a thoracic cut in *Apomatus* as in *Hydroides*, however, brings in a point of difference as compared with the ontogenetic development.

*j. Experiments on Group VI.* In four specimens of *Ditrupa subulata* the functional stalk was cut in two just below the terminal cup. The embryonic tissues at the base of the stalk increase in bulk and bulge out, showing an oblique suture. The stalk drops off a few days after the operation and a new operculum develops from its stump. Evidently the increase in the embryonic tissues serves as a mechanical stimulus for the dropping off of the old stalk. See Fig. 24A, B.

All the specimens of *Spirorbis Pagenstecheri* in which the operculum was removed died. There is, however, evidence that regeneration of the operculum takes place. A considerable number of the specimens just removed from their tubes showed stages of growth of the operculum from a small bud to a large full-sized operculum. Whether the process is a direct physiological one or is due to injury cannot of course be definitely stated. A periodic replacement may be connected with a possible periodic injury during the breaking out of the embryos from the brood pouch, though evidence is also lacking as to the length of life of the animals.

Several experiments on the regeneration of the opercula in

*Pomatoceros triquetroides* were started. It will be remembered that the operculum has a distinct basal suture. In about half of the specimens which were removed from their tubes it was

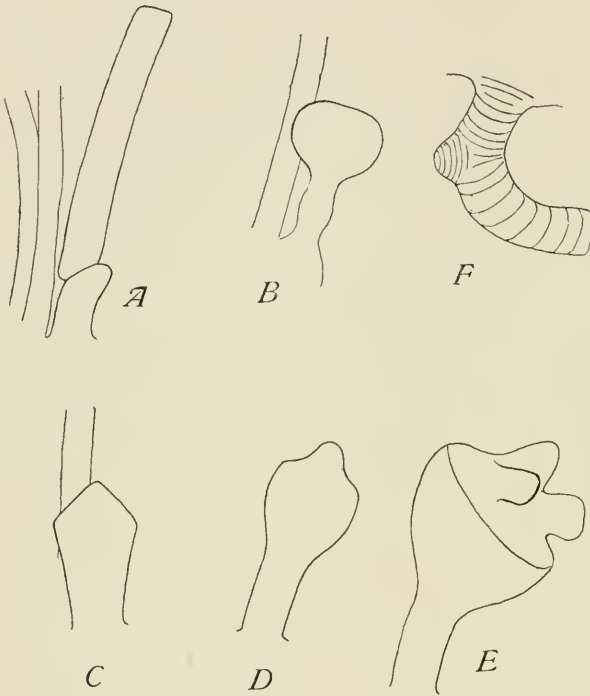

FIG. 24.

*A*—*Ditrupa subulata*. Stalk, two days after operation, showing projection of new tissue at one side of basal portion below breaking joint ( $\times 20$ ). *B*—Regenerating operculum of *D. subulata*, 9 days after operation ( $\times 20$ ).

*C, D, E*—*Pomatoceros triquetroides*. Stages in regeneration of new operculum from breaking joint level ( $\times 10$ ). *C*—Operculum just pulled off. *D*—3 days after operation. *E*—8 days after operation.

*F*—*Vermilia multivaricosa*. Stalk of operculum two days after removal of cup ( $\times 16$ ). Note projecting knob of new tissue at side of stalk.

found that the operculum had been thrown off at this basal suture, the distal portion of the operculum remaining in the tube. The plane of the fracture is not a straight one but the middle is pointed forward so as to give in a dorsal view the form of an inverted  $\Lambda$ . Figs. 8B, C; 24C, D, E. Three series of operations were carried out. In the first the operculum was cut in two distal to the basal suture. Here it seems that the part

of the operculum above the suture did not drop off but the regeneration took place by a growth from the cut surface. The first sign of this regeneration was a swelling of the terminal region from which three knobs developed, which evidently became the terminal processes of the new operculum. The evidence for this change and for the later changes in general is not complete as the later stages were not followed out.

The interesting general point is that regeneration takes place from the cut surface without a breaking off at the basal suture.

When the operculum was pulled off at the time of removal of the animal from its tube the break always took place at the  $\Delta$ -shaped suture and the regeneration then naturally followed from this level.

In a third set of experiments the animal was cut in two in the thoracic region. All such specimens, however, died before the appearance of regeneratory changes.

The operculum was removed in five specimens of *Vermilia multivaricosa*. In no case was there any regeneration of the organ. In one individual the cut was made through the narrow portion of the stalk just below the terminal cup. In this case (Fig. 24F), two days after the operation, there was a protruding knob on the median side of the stalk which may represent the beginning of an opercular regeneration, such as that shown in the case of *Ditrupa*. (Fig. 24.) In the other four specimens the cut was through the cup portion of the operculum. In all of these there was no regeneration, though three of them lived more than eleven days after the operation.

*k. Discussion of the Data.* It has been seen that the character of the regeneratory process varies according to the location of the cut. When the regeneration takes place from the breaking joint of the operculum (*Hydroides*, etc.) or of the branchial circling (*Apomatus*) the regeneration is highly specialized and the stages do not follow the ontogenetic ones very closely. When, however, the regeneration is from a thoracic cut, where the branchial and opercular tissues are not as highly specialized with respect to the mechanism of regeneration, the organs pass through a stage which may very well be compared with a corresponding stage in the ontogeny of *Hydroides*. However, even here the regeneratory development does not follow the other closely because the operculum is very evidently differentiated as such from the start in regeneration though not in ontogeny.

Our general conclusion may, therefore, be that when there is no definite mechanism for the autotomy of a region of the body the regenerating tissue may in its various stages resemble ontogenetic stages quite closely, but where a definite mechanism is present the resemblances are much less close, the development being hastened in the latter as compared with the former and both being hastened,

though in different degrees, as compared with the ontogenetic development.

The discussion of the regulation of the process may be referred to the general discussion of compensatory regulation in the group of Serpulids, as given on p. 76.

### 3. Probable Phylogenetic Development.

The opercula and branchiæ of the family Serpulidæ furnish as good a case of a morphological series as can be found within the animal kingdom. There are all gradations between species with no modification of the branchiæ up to those with a degree of opercular modification so great that no branchial characters can be made out in the organ. Furthermore, in the ontogeny of the one form studied (*Hydroides*), in which there is a high degree of modification, each of the two opercula passes through a stage in which it is to all appearances a functional branchia. The paleontological evidence, however, is fragmentary. Our only knowledge is obtained from the calcareous tubes and it is not always possible to decide whether the animal inhabitant was or was not operculate. Tubes evidently belonging to the genus *Spirorbis* are, however, found as low down as the upper Silurian.

The morphological and ontogenetic evidence leads us to the probable conclusion that the ancestors of the present day operculate Serpulids were non-operculate forms and that the opercula arose in the course of phylogeny by the development of enlargements upon the branchiæ which served to close the opening of the tube in which the animal lived.

Some speculations as to the origin of the asymmetry of the opercula in the Serpulids may be permissible if it is recognized that the course of the probable phylogeny can at present be no more than guessed at. The existence of a morphological series running from forms with no opercular modification of the branchiæ (*Protula*) through forms with a terminal enlargement at the end of each branchia (*Salmacina*), others with two equal opercular knobs one on each side of the median line attached to stalks still retaining respiratory pinnules (*Filograna*), to still others with a large operculum on one side and a small one on the other (*Hydroides*, etc.) or with one operculum and that lateral in position (*Ditrupa*, etc.) indicates that the early differentiations of the



operculum were symmetrically arranged with respect to the median line.

However, the ontogeny of Hydroides shows an asymmetry from the very first appearance of the opercular modification. Furthermore, the fact that this earliest development always occurs on the left side indicates some correlation between the character of the tube and the position of the organ. In Hydroides, however, there is an irregularity in the coiling of the tube from the very start, so that we get no evidence here of such a relation.

An examination of several Serpulids brings out the following relation between the adult position of the functional operculum and the character of the coils of the tube. A tabulation of the result is given below:

TABLE IX.

Genus	Funct. Operculum	Tube
Spirorbis . . . . .	Always right. . . . .	Dextral coil.
Pileolaria . . . . .	Always left. . . . .	Sinistral coil.
Ditrupa. . . . .	Always left. . . . .	Definite curve. Relation to animal not made out.
Pomatoceros. . . . .	Always left. . . . .	Irregular.
Vermilia. . . . .	Right or left. . . . .	Irregular.
Hydroides. . . . .	Right or left. . . . .	Irregular.
Serpula . . . . .	Right or left. . . . .	Irregular.

In the case of the definitely coiled forms *Spirorbis* and *Pileolaria* there is a very definite relation between the direction of the coil and the position of the operculum, the operculum being always on the inner side of the opening, *i. e.*, the side next to the concave side of the coil.<sup>1</sup> In *Ditrupa* this may also be true though the curve of the tube is slight and the relation between body position and the curve was not made out. The supposition of such a relation between opercular position and the curve of the tube is weakened by the fact that the tube lies freely on the sea bottom and, therefore, may lie on either side as far as known. In *Poma-*

<sup>1</sup>See Caullery et Mesnil ('96).

*toceros triquetroides* the operculum is always on the left side though the tube is irregularly coiled.

The functional operculum in the young Hydroides always appears on the left side though later in ontogeny the corresponding branchia of the other side is modified into a rudimentary operculum which possesses the power of developing into a functional one under certain conditions usually connected with injury to the operculum of the opposite side. The tube is irregularly coiled.

The constancy of position of the operculum in *Pomatoceros* and of the functional one in the larval Hydroides, notwithstanding the irregularity of the coils in the tubes, indicates that these forms may be descended from ancestors with a definitely coiled tube with which, further, the definite position of the operculum was associated. The fruitlessness of such speculations is, however, very evident, especially if an attempt be made to apply the same reasoning to the case of *Vermilia multivaricosa*, in which the single operculum may be either on the right or on the left side. The coils are here also irregular. Would it be necessary to assume a descent from a definitely (*i. e.*, not irregularly) coiled species which produced both dextral and sinistral, and, therefore, right and left operculate individuals in a manner corresponding with that of some of the species of snails? Speculation from this point of view seems to be of little value.

In connection with this discussion it may be well to state that *Vermilia multivaricosa* evidently comes under the head of the cases which Conklin ('03) seeks to explain on the basis of a reversal in the polarity of the egg, as there is no mechanism for the reversal of the opercula in post-embryonic development. The two conditions, right and left, in the present case are of practically equal occurrence.

### 3. *Comparison of Regeneratory, Ontogenetic and Probable Phylogenetic Development.*

As the data obtained from ontogeny have been used in the determination of the probable phylogeny the probability of the course of the phylogeny as given in the present discussion is weakened by the removal of these data though such a removal is made necessary by the character of the comparison. Neverthe-

less, the morphological series is so complete that there is sufficient ground for the conclusion that the opercula arose in the course of phylogeny as modified branchiæ.

The functional operculum of Hydroides has been shown to arise in ontogeny as a branchia, which later is modified to serve as an operculum. Moreover, in its modification it passes through a series of changes which corresponds very closely with the similar morphological series that may be picked up from different genera of the family. We have thus first, a stage in which the branchia is unmodified (Protula stage); second, a stage with a terminal enlargement on a branchial stalk having the ordinary respiratory filaments still present (Filograna or Apomatus stage); third, a stage in which the respiratory filaments have disappeared and in which the terminal cup has only one row of serrations (Serpula stage). The adult Hydroides condition, with two rows of serrations, is then finally attained as the result of the reversal of the opercula already described. (p. 50.) It is seen that this ontogenetic series corresponds very closely with the probable phylogenetic one.

The rudimentary operculum develops as a branchia which drops off and regenerates a rudimentary structure from the basal stump, so that it also passes through a stage which may be considered to resemble a phylogenetic one.

The *regeneratory development* falls under two heads, the development of the rudimentary operculum from the stump of the old functional or old rudimentary and the later differentiation of this into a functional. The two stages, according to the conditions, follow one another without a break or else there is a period of rest at the rudimentary stage. *The course of regeneration is characterized by a great condensation and directness of the development. There is no trace of a branchial stage and the development of the two rows of processes of the terminal cup does not follow in the ontogenetic order, that is, the more proximal row (Serpula stage) does not appear before the more distal row (Hydroides stage). The time between the appearance of the two rows is not great but the more distal row appears before the more proximal one, contrary to the course in ontogeny. The absence of a branchial stage and the reversal in the order of appearance of the two rows of processes of the cup, therefore, show a wide departure from the ontogenetic development.*

The instances so far given include those cases only which involve the regeneration of the opercula alone. When the anterior portion of the body is removed by a transverse cut the regeneration at the anterior end of the posterior piece follows a similar series as regards the development of the opercula, but the manner of regeneration of the branchial cirrlets shows a striking similarity to that of the first appearance of these organs in ontogeny. In its first stages the cirrlet consists of a group of four buds, one of which from the first shows its opercular character. The number of these buds recalls very strikingly the number in the ontogeny. The operculum here also, however, shows no trace of the branchial characters so evident in its ontogeny.

The data furnished by the opercula of the Serpulids, therefore, give a fairly close agreement between the ontogenetic stages and the probable phylogenetic ones as determined by the usual criteria. *The regeneratory* development, however, follows a course which may be modified by the character of the operation that leads to the regeneration.

#### 4. *General Discussion of the Facts of Compensatory Regulation in the Opercula of Serpulids.*

The data of both ontogeny and regeneration show that when the opercula have an equal start in development they develop as equal organs. When, however, one has an advantage over the other as regards the time of starting it exerts a retarding influence upon the other and holds the latter in a rudimentary condition. The rudimentary operculum very evidently is either continually held in check by a stimulus from the opposite fully developed operculum or else there is no such continual retarding stimulus, and the removal of the functional produces the positive stimulus for further development, or both these conditions may hold. The manner in which the presence of the large organ on one side acts upon the smaller organ is, of course, not known, but there are various arguments in favor of the view that the control may be a nervous one. The experiments of Wilson ('03) on the nervous control of the process of reversal of the chelæ in *Alpheus*, my observations on the regeneration of the branchial cirrlets and tail knobs in Serpulids in connection with the cut ends of the here widely

separated nerve cords and other cases, for which reference must be made to a future paper, indicate such a control. (See p. 62.)

The study of the ontogeny of the opercula in Hydroides has cleared up the subject greatly. It is seen that the experimentally obtained reversal is merely an expression of a normal developmental process. The primary functional operculum develops as an asymmetrically placed (left) structure and by virtue of its early development holds in check the embryonic opercular tissue of the opposite side. Later the primary functional operculum drops off, the former rudimentary tissue is no longer retarded, and, therefore, develops to a functional stage when it in turn restricts the now developing bud of the other side. Evidently the experimental reversal is merely an expression of this same process, the artificial removal of the functional operculum by a transverse cut causing the removal of the retardation effects on the opposite bud, and at the same time hastening the formation of the embryonic tissue at the basal suture of its own side, therefore leading to the dropping off of the remnant of its stalk above the suture and leaving room for the new rudimentary to develop as far as the now rapidly developing new functional of the opposite side will allow it. The fact that there is such a retardation effect of the larger organ on the smaller is further indicated by the fact that after transverse section of the body the two opercula which develop are both large and resemble the functional in general character though differing from it in particulars. The same thing is further indicated by the possibility of an explanation on this basis of the complicated results obtained when both opercula are cut off. It has been shown (p. 61) that assuming such an interaction between the opercula as here given we can explain the development of two functionals in one group and the reversal of the opercula in the other by the earlier dropping off of the functional stalk in the former group as compared with the latter, giving the bud of the functional side in the first case an equal chance in the competition with the opposite one, which chance it does not possess in the second case.

#### IV. THE RATE OF DIFFERENTIATION DURING REGENERATION OF THE OPERCULA IN THE SERPULID, APOMATUS.

The effect of the size of the piece upon the rate of regeneration of the opercula may be very conveniently studied in this species

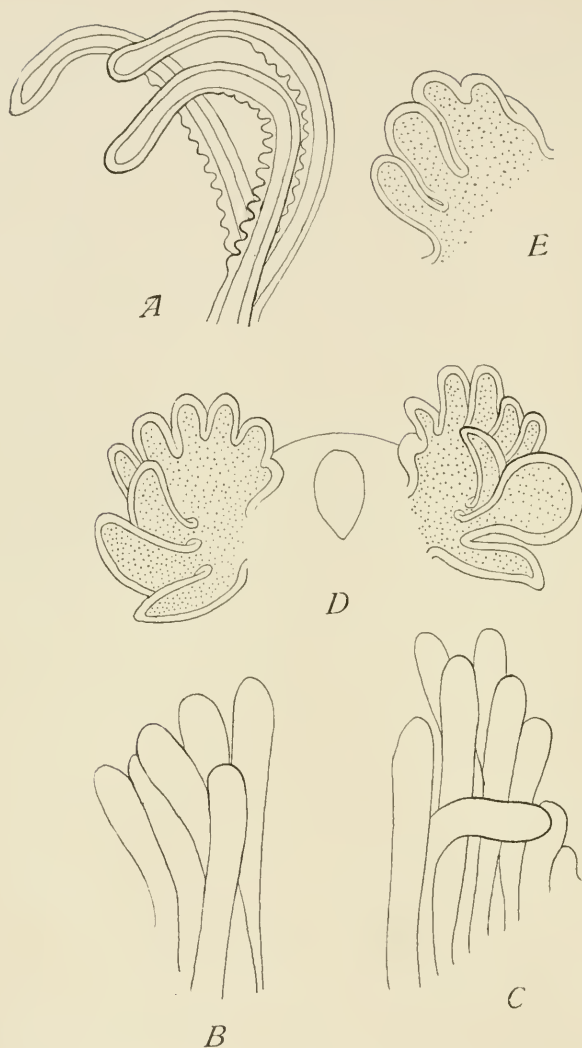

FIG. 25.

*Apomatus ampullifera*. *A*—Operation: Branchial cirrilli cast off at breaking joint. Body intact. Figure of three most dorsal branchiae of right side 9 days after operation. No opercular differentiation ( $\times 45$ ). *B*—Operation: Same as in *A*. Figure of regenerating right branchial cirrillus 6 days after operation. No opercular differentiation. *C*—Left branchial cirrillus of same ( $\times 62$ ). *D*—Operation: Branchial cirrilli thrown off at breaking joint. Body posterior to third thoracic segment removed. Eight days after operation. Note opercular differentiation ( $\times 62$ ). *E*—Operation: Same as *D*, except that thoracic cut is at second segment. Figure shows the regenerating left branchial cirrillus 6 days after operation. Note beginning of opercular enlargement.

because there is a very definite line of cleavage along which the break always takes place, and similar materials may be assumed to exist at the regenerating surface at the time of the operation in all individuals of a set of experiments. If, therefore, the body is cut in two at various levels and the branchiæ are thrown off at the "breaking joint" any differences in the regeneration of the branchiæ and opercula may be considered as due to differences in the posterior body operations.

In the *first* lot of *Apomatus* the branchiæ were removed in the manner mentioned but there was no operation on the body. In the *second* lot the body was cut between the third and fourth thoracic segments in addition to the removal of the branchiæ, and in a *third* lot the thoracic cut was made between the first and second segments. The last two operations in a great number of the cases naturally caused the death of the animals, but in general a very interesting result was obtained. In the cases where the body was cut in two in the thorax as mentioned *the opercular differentiation appeared much earlier than in those in which the body was intact.*

When the body is uninjured except for the removal of the branchial circlets the branchial buds to the number of eight or nine on each side appear simultaneously or nearly so, although there is a slight gradation in size from dorsal to ventral edge of the branchial ridge from the beginning. The few remaining buds to be developed are added from the ventral edge. These bud-like processes increase rapidly in length and soon appear as long slender filiform processes which usually take on the secondary pinnules before the appearance of the first traces of opercular differentiation. The opercular differentiation then appears as a vesicular enlargement in the next to the dorsal branchia on each side.

In the two-segment and four-segment thoracic pieces, left by the thoracic cuts in lots two and three, the development does not follow this course. The opercular bud is from the start very evidently different from the others, being larger and more spherical than the branchial buds proper. This is well shown in the figures. (Figs. 25 and 26.) The branchiæ in this case, however, are also thicker and shorter than the corresponding ones where the body remains intact. It is very evident that while in the one case where the body is intact the operculum passes through a distinct

branchial stage before showing even a beginning of an opercular knob, in the other case where only the anterior two or four segments remain the operculum appears as such from the start.

Unfortunately the animals in the last two lots did not live long enough to show whether or no the final outcome would have been the same in the two cases. In fact none of them showed any pinnules on the branchiæ at the time of death. Notwithstanding



FIG. 26.

*Apomatus ampullifera*. Regenerating branchial circlets. Nine days after operation ( $\times 40$ ). Operation: Autotomy of both branchial circlets at breaking joint and removal of body posterior to second thoracic segment. Note pronounced opercular differentiation on both sides.

these limitations it is evident that we have a definite acceleration of the rate of differentiation of the opercula.

Two probable factors may be mentioned as concerned in the bringing on of the acceleration. 1. The shock of the transverse division of the body may lead to such an increase in rapidity of differentiation. 2. The small size of the piece itself may directly influence the process and bring about such a differentiation. This action may result because of the difference in the interactions of the organs in the one case as compared with the other.



V. REGULATION OF THE RATE OF GROWTH AND NATURE OF DIFFERENTIATION DURING REGENERATION OF THE CHELÆ OF GELASIMUS AND ALPHEUS.

I. *Introduction.*

The general problem to be taken up in the experiments on the chelæ of the two Decapod Crustaceans mentioned corresponds with that already given for the Serpulids. The interactions of the two chelæ naturally constitutes the principal point of study. Likewise the influence of the removal of one or both chelæ upon the rate of moulting of the animals will be discussed and some further incidental points will be touched.

In *Gelasimus pugilator* the two chelæ are of nearly the same size and character in the female but differ widely in the male. In *Alpheus dentipes* the chelæ differ both in size and character in both male and female.

2. *Gelasimus Pugilator.*

In *Gelasimus* the male has one of the two chelæ enormously developed. This large chela is nearly equally distributed between right and left sides in a group of individuals taken at random. In the female the two chelæ are small and equal in size. The animals readily autotomize their legs if a needle is inserted between two of the joints distal to the "breaking joint" so as to touch the nerve. In the following experiments the animals were made to throw off their chelæ in the way mentioned. They were kept in glass dishes with just sufficient water to keep them moist and fed with bits of the horse-mussel, *Mytilus*. Under these conditions they lived very well, though unfortunately the growth of the new legs was extremely slow and the experiments could not be completed as satisfactorily as was wished.

1. Experiments on Males.

a. *Large Chela Alone Removed.* The first object of the work was to determine whether reversal of the character of that of *Hydroides* takes place in these forms. The large chela was autotomized in the manner already indicated. In the great majority of the cases the animals lived through the 62 days after the operation, but in only a few did a moult take place so that the results are

not entirely satisfactory. Twenty specimens, ten with the large chela on the right side, and ten with it on the left, were treated in this way. Five specimens had moulted at the end of 62 days after the operation when the experiment was closed. The first one moulted 54 days after the operation and in this the regenerated chela (= former large one) was as yet smaller than the other (= former small one). The old small one had no pronounced change as a result of the moult. In the four other specimens, one of which moulted 59 and the other three 62 days after the operation, the new regenerated chela was in each case larger than the opposite old one, though it had not as yet attained the full size and characteristics of the typical large one.

It may be safely concluded from the above observation that no reversal of the chelæ in the sense of the reversal of opercula in *Hydroides* takes place in the males of *Gelasimus* after removal of the large chela, for it seems evident that in the first case mentioned, where the regenerated chela was as yet smaller than the old small one of the opposite side, it had not yet reached its full growth. In further support of this view is the fact that no pronounced change in the old chela was noticed.

*b. Small Chela Alone Removed.* The following results were obtained when the small chela alone was removed: Only four of the ten specimens moulted before the end of the 62 days, constituting the limit of the experiments. In all of these the newly regenerated chelæ were much smaller than the opposite large ones and approached in character the ordinary small chelæ. The four specimens mentioned moulted, respectively, 48, 61, 61 and 62 days after the operation. Therefore, here also there is no reversal of the chelæ.

*c. Both Chelæ Removed.* In this set of experiments both chelæ were autotomized. Ten specimens were kept for 62 days and eighteen for 42 days. Seven of the former moulted and showed the characters of the regenerated chelæ. In each of the seven a large chela was regenerated in place of the former large one and a small chela in place of the former small one. There was no reversal. The chelæ after the first moult did not of course as yet have the full size of the old ones but the difference in size was very evident.

In one of the seven cases mentioned here as having moulted so as to show the characters of the regenerated chelæ one specimen

showed an abnormality in that the smaller regenerated chela had two pinchers at its end. This case will be described in a separate note at another time.<sup>1</sup>

*d. Two normal male specimens* kept in glass dishes for 62 days did not moult or show any changes. They were fed on fragments of *Mytilus* in the same manner as the others.

## 2. Experiments on Females.

*a. Removal of One Chela* (right or left). Two of the six specimens moulted before the completion of the experiment. In one of these the regenerated chela was a trifle smaller than the opposite one. In the other the two chelæ, the old and the regenerated one, were nearly equal in size after the moult. One of these specimens moulted 56 days, the other 62 days after the operation.

*b. Removal of Both Chelæ.* Only three specimens were operated on in this way. All had moulted within 46 days after the operation. The new animals regenerated two new and equal chelæ. The regenerated structures, therefore, repeat the character of the removed appendages.

## 3. The Rate of Regeneration and of Moulting After the Operation. (Male and Female.)

The data show very plainly that the moulting takes place sooner in the cases where both of the chelæ are removed than in the cases where only one or none are removed. In fact all three members of the female set with both chelæ removed moulted before any of those with only one chela removed had done so. It does not seem possible that the matter of accident can come in here as there are too many cases both as regards this point and as regards other related ones.

A general comparison in both males and females of the cases in which both chelæ were removed with those in which only one or none were removed bring out an interesting result.

1. *Time of moulting.* *The specimens with both chelæ removed moulted sooner than those with only one chela removed.*

2. *The regenerating buds in the specimens where both chelæ had been removed were in general larger than the corresponding buds*

<sup>1</sup> Biol. Bull., '05.

where only one chela was removed. This statement is of course not a definite quantitative one on account of the difficulty in estimating relative sizes, but becomes interesting in connection with the following results on *Alpheus* (p. 85, *ffl.*) and the former cases already described.

*The results, therefore, indicate that where two chelæ are removed the time of moulting is hastened and the rate of regeneration of each chela is increased as compared with the cases where only one chela is removed.*

#### 4. Rate of Moulting after Removal of One or Both Eystalks. (Male and Female.)

Three sets of experiments were performed.

*a.* In one set of three females the right eystalk was cut off near its base. Pigment very soon collected near the cut end so that the region assumed a color much darker than the normal eye color. A similar change took place in all the other experiments after the cutting of the eystalk.

*b.* In another set there were three males, one with the large chela on the left and two with it on the right side. The right eystalk was cut off near its base. The first noticeable change as in the last set was a collection of very dense pigment at the cut surface. All three of the specimens moulted before the close of the experiment, one 56 days, another 58 days and the third 61 days after the operation. At moulting the dark pigment of the cut surface disappeared and the end of the new eystalk was rounded and resembled the old eystalk except that it was shorter.

*c.* In a third set of four males and one female both eystalks were cut off near their bases. Two of the specimens lived for more than a few days. One moulted 14 days after the operation but was found dead and broken after the moult. In the other one the cut surfaces of the eystalks were black with pigment at this time and also five days later, 19 days after the operation. This specimen moulted 23 days after the operation, at which time the eystalk ends were rounded but there was no appreciable increase in eystalk length. The very dark pigment disappeared with the moult as in the last series. The animal died 40 days after the operation.

*d. Conclusion.* In the specimens with an eystalk operation the time of moulting was hastened as compared with unoperated

specimens. In the cases where both eyestalks were removed the moults came sooner (14 and 23 days) than when only one was removed (56, 58 and 61 days). Here again, therefore, there is a hastening of the physiological process in the cases of a greater disturbance as compared with those of a lesser disturbance of the organism.

### 3. *Alpheus Dentipes*.

#### 1. Introduction and Review of Former Work.

The reversal of the cutting and snapping chelæ of *Alpheus* has been demonstrated and the process studied by Przibram ('01, '02) and recently by Wilson ('03) and Brues ('03, '04). It has been shown that when the snapping claw is removed, the cutting chela of the opposite side is differentiated into a snapping chela, while in place of the removed snapping chela a new cutting chela is developed. When the cutting chela alone is removed there is no reversal, a new cutting chela developing in place of the old. When both chelæ are removed there is again no reversal, a new snapping chela being regenerated in place of the old snapping and a new cutting chela in place of the old cutting one. In the latter case Przibram, working on *A. dentipes* and *A. platyrrhynchus* mentions



FIG. 27.

Chelæ of *Alpheus dentipes* ( $\times 4$ ). Left-hand figure: cutting chela. Right-hand figure: snapping chela. Dotted lines represent the lengths measured (see text, p. 91).

the fact that the newly regenerated cutting chela is relatively larger as compared with the snapping chela than in the animal before the operation. Wilson's result on the Beaufort, N. C., species (*A. heterochelis*) agrees with that of Przibram except that in the case where both chelæ were removed the new cutting chela does not approach the new snapping chela as nearly as in the species upon which Przibram worked. Wilson further added the interesting result that when the snapping chela is removed and the nerve leading to the cutting chela is cut below the breaking joint

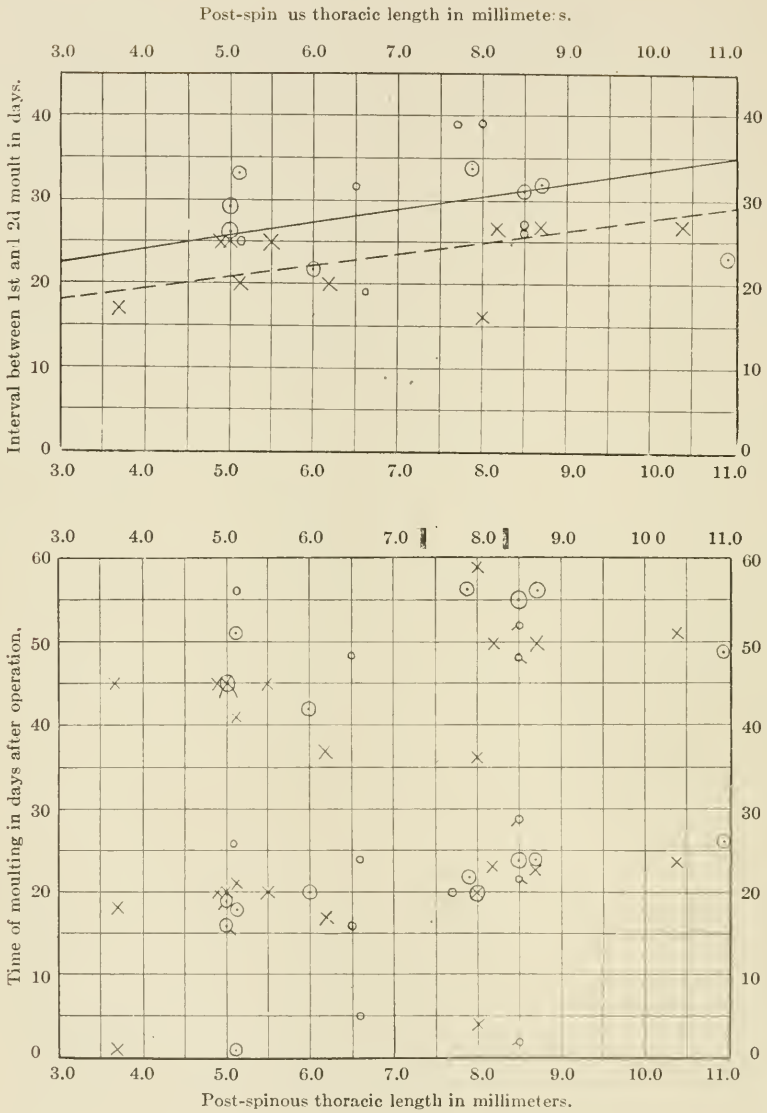

FIG. 28.

*Alpheus dentipes*. Lower data—Time of moult in days after operation. Upper data—Interval between first and second moult in days. Abscissæ are post-spinus thoracic lengths.  $\circ$  = Cutting chela (Cu) alone removed.  $\odot$  = Snapping chela (Sn) alone removed.  $\times$  = Both chelæ (Cu + Sn) removed. In the upper data the upper line is drawn to fit the first two groups of cases (one chela alone removed) and the lower line to fit the last group (both chelæ removed).

“the reversal in some cases at least does not take place or is incomplete.” Brues (Wilson, '03, p. 210) adds the interesting fact that in *A. heterochelis* the nerves supplying the two chelæ and the ganglionic centers from which they proceed do not differ perceptibly in size.

## 2. The Data.

The experiments about to be described in the present section of the paper were performed at the Naples Zoölogical Station in the winter of 1902-03. They confirm the general facts of reversal of the chelæ as given above. Their main object, however, was the determination *first*, of the effect of the removal of one or both chelæ upon the rate of moulting of the animal, and, *second*, of the influence of the presence or absence of the opposite chela upon the rate of regeneration of a chela.

*a. The Influence of the Removal of One or Both Chelæ upon the Rate of Moulting of the Animal.* Three sets of specimens were operated on. In one set (*Sn*) the snapping chela alone was removed. In a second (*Cu*) the cutting chela alone was removed. In a third (*Sn + Cu*) both snapping and cutting chelæ were removed. The animals were kept in isolated dishes for 59 days after the operation and were fed either every day or every other day on small pieces of fresh fish meat. Without taking into account the cases where the legs were accidentally autotomized a second time during the experiment, or in which other disturbances occurred, we have the following relation between the time of moulting and the post-spinous thoracic length of the animals without reference to the character of the operation: On the coördinate paper (Fig. 28, p. 86) the abscissæ represent the thoracic lengths in millimeters and the vertical columns (ordinates) the days after the operation when moulting occurred. The animals were killed 59 days after the operation. The data from the first set (*Cu*) are represented by the symbol  $\circ$ , those of the second set (*Sn*) by the symbol  $\odot$  and of the third set (*Sn + Cu*) by  $\times$ . It will be seen that in general the moulting interval increases with the size of the animal as represented by the thoracic length.

On pp. 88 and 89 the data are put in Tables X, XI and XII, each of the sets being placed by itself. The interval of time in days between the first moult and the second moult is put down in a separate column. Upon averaging this interval in the three

sets separately it is found that *the interval decreases from 29.6 days for the Cu set and 28.7 days for the Sn set to 22.9 days for the Sn + Cu set.* This result is represented on coördinate paper on p. 86, Fig. 28.

When two chelæ are removed there is, therefore, a shortening of the period between the first two moults as compared with the cases where only one chela is removed. It will be seen that there is only a slight difference between the moult period in the two single chela cases. This result agrees perfectly with that obtained for the time of appearance of the first moult in *Gelasimus*, where

TABLE X. *Alpheus dentipes.* Time of Moulting. Cutting Chela (R or L) Removed.

Cat. No.	Thoracic Length.	Date of Operation.	1st moult.	2d moult.	3d moult.	Interval 1st-2d.
		1903				
562	6.6	1/8	5	24	—	19
565	8.5	1/8	2	29	52	27
569	8.0	1/8	20	—	—	39+
573	8.5	1/9	22	48	—	26
576	6.5	1/9	16	48	—	32
579	5.1	1/9	1	26	56	25
582	7.7	1/9	20	—	—	39+
Av. =						29.6

it was found (p. 83, *ffl.*) that the specimens with both chelæ removed in every case except one moulted before those with only one chela removed.

The greater disturbance of the normal condition of the animal here again causes greater activity as regards the moulting period. Starting with the smallest disturbance and going upward we have a series ranging, respectively, through (1) cutting chela removed, through (2) snapping chela removed, to (3) both chelæ removed. Correspondingly, the interval between the first and second moult decreases from 29.6 days, through 28.7 days to 22.9 days for the cases named.



TABLE XI. *Alpheus dentipes* Time of Moulting. Snapping Chela (R or L) Removed.

Cat. No.	Thoracic Length.	Date of Operation.	1st moult.	2d moult.	3d moult.	Interval 1st-2d.
561	8.7	I/7	24	56	—	32
563	7.9	I/8	22	56	—	34
575	8.5	I/9	24	55	—	31
578	5.0	I/9	19	45	—	26
581	5.0	I/9	16	45	—	29
617	6.0	I/7	20	42	—	22
619	11.4	I/7	26	49	—	23
620	5.1	I/7	18	51	—	33
Av. =						28.7

TABLE XII. *Alpheus dentipes*. Time of Moulting. Both Chelæ Removed.

Cat. No.	Thoracic Length.	Date of Operation.	1st moult.	2d moult.	3d moult.	4th moult.	Interval 1st-2d.
		1903					
566	6.2	I/8	17	37	—	—	20
567	8.7	I/8	23	50	—	—	27
571	10.4	I/9	24	51	—	—	27
574	8.2	I/9	23	50	—	—	27
577	5.5	I/9	20	45	—	—	25
580	4.9	I/9	20	45	—	—	25
583	5.0	I/9	20	45	—	—	25
584	5.1	I/9	21	41	—	—	20
585	3.7	I/9	1	18	45	—	17
618	8.0	I/7	4	20	36	59	16
Av. =						22.9	

SUMMARY OF TABLES X, XI, XII. Comparison of Interval Between First and Second Moults.

*Cu* Removed = 29.6 days. (Av. of 7 cases.)

*Sn* Removed = 28.7 days. (Av. of 8 cases.)

*Cu* + *Sn* Removed = 22.9 days. (Av. of 10 cases.)

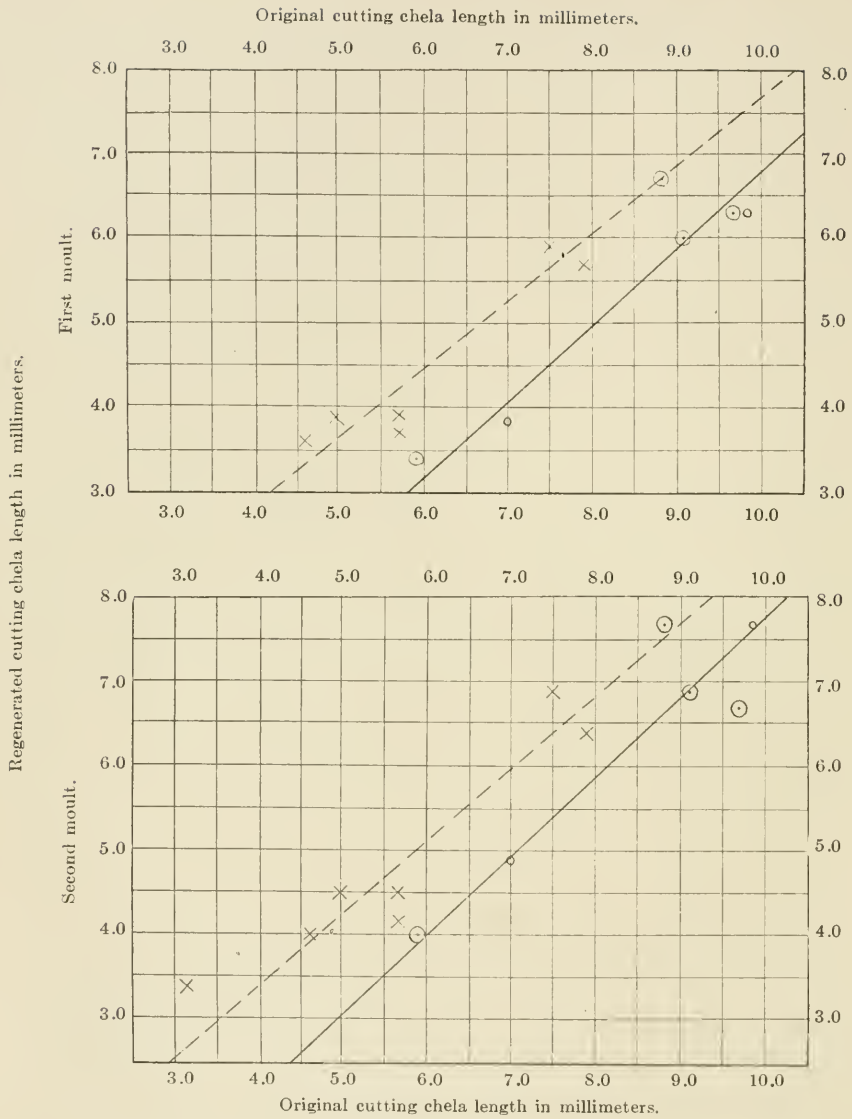

FIG. 29.

*Alpheus dentipes*. Lengths of regenerating cutting chelæ at the end of the first and second moults. Ordinates = Regenerated cutting chela lengths in mm. Abscissæ = Original cutting chela lengths. ○ = Cutting chela (Cu) alone removed. ⊙ = Snapping chela (Sn) alone removed. × = Both chelæ (Cu + Sn) removed. The broken lines fit the last group (both chelæ removed) and the unbroken lines fit the first two groups (one chela alone removed).

*b. The Influence of the Presence or Absence of the Opposite Chela upon the Rate of Regeneration of a Removed Chela.* A comparison was made of the regenerated lengths of the cutting chela in cases where only one chela was removed with cases where both chelæ were thrown off.

When the cutting chela alone was autotomized a new cutting chela was regenerated in its place. When the snapping chela alone was removed there was a reversal and the old cutting chela was differentiated into the new large snapping chela, while in place of the removed snapping chela a typical cutting chela was developed. In the second case this new cutting chela is the one taken in our measurements. In a third case both chelæ were thrown off, a new cutting chela regenerating in place of the old cutting chela and a new snapping chela in place of the old snapping one. The lengths are taken from the moulted casts of the animal, the original length being taken from the cast of the first moult, the first moult condition from the cast of the second moult, etc. The final measurements are taken from the alcoholic specimens of the animals killed 57 days in each case after the operation. The lengths measured in the data about to be described are the greatest lengths of the cutting chela, *i. e.*, the distances from the tip of the pincher process of the fourth podomere to the farthest corner of the base. (Fig. 27.) The chelæ or their casts were in every case drawn carefully to scale by the aid of a camera lucida and the measurements are taken from these drawings. Out of 29 specimens kept for 59 days only 12 can serve for first moult data and 13 for second moult data. The others are not valid because of the death or escape of the animal or the accidental secondary autotomy of one or both of its appendages.

The relation of the regenerated chela lengths to the original lengths is shown on coördinate paper (Fig. 29) for both the first and the second moult. The number of individual cases is small, but it is evident that the regenerated lengths of the cutting chela in the cases where both chelæ were removed have a distinct advantage over the others. This is especially clear for the first moult.

The relation comes out very clearly when we take the ratio between the regenerated cutting chela length and the original length in that specimen as our basis for comparison, for we see that the regenerated length increases as we go from small original lengths to large original lengths. As the cases given on the coör-

dinate paper (p. 90, Fig. 29) show, the correlation is not a perfect one, *i. e.*, it is positive but equal to slightly less than one. The results of such a comparison are given for both the first and the second moults in Tables XIII–XVI.

TABLE XIII. *Alpheus dentipes*. Length of Regenerated Cutting Chela. Cutting Chela Removed.

Cat. No.	Original Cu. Lg.	Reg. Cu. Lg. 1st moult.	$\frac{\text{Regen. Cu.}}{\text{Orig. Cu.}} \times 100$	Reg. Cu. Lg. 2d moult.	$\frac{\text{Reg. Lg.}}{\text{Orig. Lg.}} \times 100$
573	7.0	3.8	54.3	4.9	70.0
576	9.8	6.3	64.3	7.7	78.6
—	—	—	59.3	—	74.3

TABLE XIV. *Alpheus dentipes*. Length of Regenerated Cutting Chela. Snapping Chela Removed.

Cat. No.	Original Cu. Lg.	Reg. Cu. Lg. 1st moult.	$\frac{\text{Regen. Cu.}}{\text{Orig. Cu.}} \times 100$	Reg. Cu. Lg. 2d moult.	$\frac{\text{Reg. Lg.}}{\text{Orig. Lg.}} \times 100$
561	8.8	6.7	76.1	7.7	87.8
563	9.1	6.0	65.9	6.9	75.8
575	9.7	6.3	64.9	6.7	69.1
578	5.9	3.4	57.6	4.0	67.8
—	—	—	66.1	—	75.1

The tables show that *Cu* + *Sn* has a very distinct advantage over *Cu* alone or *Sn* alone. This advantage amounts to 19.1 per cent for the first moult and 16.5 per cent for the second moult. Just after the first moult the cutting chela regenerated from the breaking joint surface of what was formerly the snapping claw has a distinct advantage over the cutting chela regenerated from a removed cutting chela but this advantage is nearly overcome at the time of the second moult.

TABLE XV. *Alpheus dentipes*. Length of Regenerated Cutting Chela. Both Chelæ Removed.

Cat. No.	Original Cu. Lg.	Reg. Cu. Lg. 1st moult.	Regen. Lg. $\times 100$ Orig. Lg.	Reg. Cu. Lg. 2d moult.	Reg. Lg. $\times 100$ Orig. Lg.
	566	5.7	3.7	64.9	4.2
567	7.5	6.4	85.3	6.9	92.0
574	7.9	5.7	72.2	6.4	81.0
577	5.7	3.9	68.4	4.5	78.9
580	3.2	—	—	3.4	106.2
583	4.6	3.6	78.3	4.0	86.9
584	5.0	3.9	78.0	4.5	90.0
—	—	—	74.5	—	87.0

TABLE XVI. Summary of Tables XIII, XIV and XV.

		First Moult.	Second Moult.
Original data.			
Regenerated Lg. $\times 100$ ...	Cu	59.3	74.3
Original Lg.	Sn	66.1	75.1
	Cu + Sn	74.5	87.0
Comparisons.			
Absolute difference .....	(Cu + Sn) - Cu	+15.2	+12.7
	(Cu + Sn) - Sn	+ 8.4	+11.9
	Sn - Cu	+ 6.8	+ .8
Per cent of increase .....	$\frac{(Cu + Sn) - Cu}{Cu}$	+25.6	+17.1
	$\frac{(Cu + Sn) - Sn}{Sn}$	+12.7	+15.8
	$\frac{Sn - Cu}{Cu}$	+11.5	+ 1.1

The general result is clear. The regenerated cutting chela is larger in the case where two chelæ are regenerating than where one alone is to be replaced. This result is emphasized by the fact that the time between the first two moults is shorter in the specimens with two chelæ removed than in those with only one gone. (See p. 87.)

### 3. Discussion.

The significance of the data may be emphasized by bringing them out in two ways, one of which lays special stress upon the fact of removal of a certain organ or organs and the necessity of a certain amount of regulation in restoring the normal form, and the other of which emphasizes rather the interactions of the two chelæ as parts of a system normally stable at the condition with a large snapping chela on one side and a small cutting chela on the other.

The first point of view in which the total necessary amount of regulation is compared with the rate of regeneration of a part of the whole will first be taken up. The three series of experiments may be compared in the following way:

1. With the cutting chela alone gone the animal has merely to accomplish the regeneration of this organ in order to regain its normal condition.

2. With the snapping chela alone gone the animal has not only to regenerate a cutting chela in place of the old snapping one but also to differentiate the tissue of the old cutting chela into the new snapping chela.

3. With both chelæ gone the animal has not only to regenerate a new cutting chela in place of the old one but also to regenerate a new snapping chela.

Taking the ratios given in Table XVI, p. 93, we see that in the first case where the least work is to be accomplished, at the end of the first moult the cutting chela has regained but 59.3 per cent of its original size, while in the second case it has reached 66.1 per cent, and in the third case 74.5 per cent of its original size. At the end of the second moult likewise we have, respectively, 74.3 75.1 and 87.0 per cent for the three cases in question.

*Therefore, the amount of actual regeneration accomplished in the cutting chela is greater the greater the amount of other work of a similar character to be accomplished at the same time.*

But if we consider the matter from the second point of view, namely, of the influence of the presence of another similar and opposite organ upon the regenerating tissue, the apparent anomaly of the case is cleared up to a great extent. For it is seen that in the first case (*Cu* alone removed) we have an uninjured opposite large snapping chela to retard the growth of the regenerating cutting chela. In the second case (*Sn* alone removed) we have as the retarding agent at the beginning merely the smaller *Cu* chela which, however, gradually undergoes the changes in size and character leading up to the large snapping chela. Finally, in the third case (*Cu* + *Sn* removed) we have at the beginning no retarding agent, though gradually the snapping chela develops from this point.

Expressing this in concise form we have the following relation referring to the *retarding agent* as indicated by the size and complexity of differentiation of the chela situated on the side opposite to the developing cutting chela:

The *snapping chela* in the group where the cutting chela alone is removed is greater than the *cutting chela developing into a snapping chela*, as in the group where the snapping chela alone is removed and this in turn is greater than the retarding agent where both chelæ are removed, and which amounts to *zero at the beginning with a gradual development up to a snapping chela condition*.

And referring to the corresponding regenerated lengths of the cutting chela we have:

The amount of regeneration of the cutting chela in the first group (*Cu* alone removed) is less than the amount of regeneration of the cutting chela in the second group (*Sn* alone removed), and this in turn is less than the amount of regeneration of the cutting chela in the third group where both chelæ are removed.

In graphic form this may be represented as follows:

Snapping chela [as in *Cu* group] >  
 Cutting chela (→ snapping chela) [as in *Sn* group] >  
 Zero (→ snapping chela) [as in (*Cu* + *Sn*) group].

Correspondingly,

Amount of regeneration of cutting chela in *Cu* group  
 < Amount of regeneration of cutting chela in *Sn* group  
 < Amount of regeneration of cutting chela in *Cu* + *Sn* group.

Evidently the differences between the retarding influences of the three members are greatest near the beginning of the experiments, *i. e.*, immediately after the operation, and gradually decrease as we go away from this point. Correspondingly, the results show a greater comparative difference in regenerated material at the end of the first moult than at the end of the second moult.

This result agrees very well with the experiments on the fiddler-crab *Gelasimus* (p. 81) and on the brittle-star *Ophioglypha*, (p. 7).

As moulting involves not only an increase in bulk of the animal but also a complicated degree of differentiation of materials before it can be accomplished, we may likewise compare the acceleration of moulting in *Alpheus* and *Gelasimus* with the acceleration of the rate of differentiation of the opercula in *Apomatus* when the posterior region of the body is also removed as compared with the cases where this region is uninjured.

#### GENERAL DISCUSSION.

The following discussion does not serve as a summary of the data of the preceding sections. For this the reader must be referred to the summaries of the individual sections which are complete entities in themselves. It is the writer's purpose in the general discussion to show the manner in which the various data, at first sight seeming to have little in common, can be brought under a common point of view.

In the introduction it was stated that the standpoint of the present paper would be the consideration of the organism as a system made up of mutually interacting parts, the relations of which were to be studied by noting the disturbances produced as a result of the removal of one or more of the parts.

In the paper on the dimensional relations of the members of compound leaves the relations of the parts of a system were studied in which the removal of one member was not followed by its regeneration but resulted in changes in size and position of the remainder. The chief reactions were the following: In the five-leaved forms in which an asymmetrically placed leaflet was removed the other four leaflets tended to rotate to a position such that the new system was a symmetrical four-leaved one. Like-



wise in the three-leaved system after removal of one of the asymmetrically placed leaflets the two remaining leaflets tended to take up a position so as to form a symmetrical two-leaved system. From the position reactions it is evident that the parts of the normal compound leaf are exerting a continual influence upon each other which when resolved into its resultants gives rise to a configuration very definite for a given species. The removal of one of the parts changes the whole system of reactions, and we have a tendency toward the formation of a new stable symmetrical system, with one less leaflet than the original number, the completeness of the new symmetry being only limited by the rigidity of the leaflets.

In *Ophioglypha* we have a radial system in which the removed arms are regenerated. The experiments on the rate of regeneration bring out the presence of an unsuspected interaction between the arms which must naturally be correlated with some interaction present in the perfect, unamputated animal. The data of the experiments show that (leaving out of consideration the cases where all five arms are removed and which cannot be used because of the early death of the animals) the rate of regeneration of an arm is greater the greater the number of other arms removed at the same time. This indicates an interesting interaction of the arms upon each other for the presence of unremoved arms seems to retard the rate at which the removed ones are regenerated, for it is not probable that the increase in rate in the one case is due entirely to the increase in stimulus to regeneration produced by the added injuries.

The two members of a pair of appendages in bilateral animals have been shown by the present experiments to have a profound influence upon each other.

In those *Serpulids*, for example, which have one large functional and one small rudimentary operculum it has been shown that either organ originally has the potentiality of developing into a functional operculum, which is to be developed in this way, depending upon the matter of an early start. When one side gets a start over the other the development of the latter is restricted to a rudimentary stage, while the former develops to a full functional size. Also, when the functional operculum is removed its restricting influence being removed at the same time, the rudimentary operculum immediately develops into a functional one, which in turn restricts the developing new bud of the other side. When both develop at

the same time, as from the anterior cut surface of the thorax, two functional opercula are formed.

Similarly, in the Decapod Crustaceans the two chelæ have a profound influence upon each other.

In *Alpheus* there are two chelæ, one a larger "snapping" chela and the other a smaller "cutting" chela. The snapping chela seems to hold the cutting chela in check, for as soon as the former is thrown off the cutting chela changes over to the snapping chela by a qualitative and quantitative change combined. The new organ regenerating in place of the old snapping chela comes into a system no longer relatively like the old, so that the interaction of parts forces it into a different niche in the new order of things. The reversal, here as in the Serpulids, is easily understood in the way mentioned, if we consider the systems as asymmetrical interacting systems such that the removal of one part can lead only to the development of a certain definite structure. The removal of the organ (functional operculum or snapping chela) brings about an instability in the system which because of the reactions between the parts tends to assume the condition of a new *stable* system. This new system reacts now in a different way on the regenerating organ, causing it to develop into a different structure. The readjustment in the old material and in the regenerating material is further complicated by the fact that both processes go on at the same time, the final outcome being the resultant of both.

In *Alpheus* as also in *Gelasimus* we have an interesting relation between the two chelæ, in that when both are removed the rate of regeneration is greater in each than when one alone is removed. Evidently this comes under the Ophioglypha relation that the presence of an unremoved organ retards the rate of regeneration of a removed one. Likewise if we consider the cutting chela of *Alpheus* as a stage in the development of the snapping chela (Wilson, '03) and the rudimentary operculum as a stage in the development of the functional, we can say that the presence of the larger organ retards the differentiation of the smaller one. This comes into relation with the series of experiments on the rate of differentiation of the regenerating opercula in *Apomatus*, in which it was found that the absence of the posterior region of the body back of the second or fourth thoracic segment accelerates the rate of differentiation of the regenerating opercula.

From the point of view of the retarding influence exerted by one organ upon another the data that have been brought out in the present paper may be collected in the following concise form:

1. *Ophioglypha*. Arms *a, b, c, d, e*.

$a_1$  = Rate of regeneration of an arm when it alone is cut off.

$a_2$  = Rate of regeneration of an arm when two arms are cut off, etc.

$r_{a_1}$  = Retardation as result of influence of remaining arms on  $a_1$ , etc.

Then

$$a_5 = a_4 + r_{a_4} = a_3 + r_{a_3} = a_2 + r_{a_2} = a_1 + r_{a_1}$$

arms remaining = none, *e*, *d* and *e*, *c, d* and *e*, *b, c, d* and *e*.

In the above  $a_5 > a_4 > a_3 > a_2 > a_1$

and  $0 < r_{a_4} < r_{a_3} < r_{a_2} < r_{a_1}$ .

2. *Hydroides*. Opercula,  $OF_{R \text{ or } L}$  and  $OR_{L \text{ or } R}$ .

$OF_{R \text{ or } L}$  = Functional operculum, right or left.

$OR_{L \text{ or } R}$  = Rudimentary operculum, left or right.

Taking for the sake of simplicity the opercula as  $OF_R$  and  $OR_L$  we have:

<i>Operation.</i>	<i>Result.</i>	<i>Explanation on "Retardation" Theory.</i>
(1) Both off.		
(thoracic cut) = $OF_R + OF_L$	No retardation of one by the other.	Therefore both reach full development.
(2) Functional off. = $OR_R + OF_L$	Reversal of opercula.	Release of normal retardation of old rudimentary and the presence of a new retardation influence upon the new rudimentary. $\therefore$ a reversal.
(3) Rudimentary off. = $OF_R + OR_L$	Full action of old retardation influence upon the new bud and therefore no change.	

3. *Gelasimus*. Chelæ  $CR, CL$ . Asymmetry in ♂ only.

In ♂ one chela is considerably larger than the other, but the condition is fixed and cannot be reversed as can the opercula of *Hydroides*.

In ♀ the two chelæ are equal.

$CR + CL$ , as compared with  $CR$  alone or  $CL$  alone, shows an acceleration of the time of moult and has each chela bud larger than the single bud of the latter.

4. *Alpheus*. Chelæ  $CR, CL$ . Asymmetry in both ♂ and ♀.

The basal ganglia controlling the chelæ are similar on the two sides (Brues).

(1.) Reversal takes place as in *Hydroides*.

(2.) Relations of time of moult and size of regenerated structure similar to those of *Gelasimus*.

5. *Apomatus*. Serpulid. Opercula OF<sub>R OF L</sub> and OR<sub>L OF R</sub>. (See Fig. 23D.)

*Operation.* Removal of two branchial cirrlets + opercula at basal suture. Uniform in all experiments.

(1) In one set of experiments body of animal is kept entire.

(2) In other set of experiments body of animal back of second or fourth thoracic segment is removed.

Result:

Rate of differentiation of new opercula in (1)	$\left\langle \begin{array}{l} / \\ \backslash \end{array} \right.$	Rate of differentiation of new opercula in (2).
because	$\left\langle \begin{array}{l} / \\ \backslash \end{array} \right.$	Retarding influence of anterior two or four thoracic segments (2).
Retarding influence of whole body (1)	$\left\langle \begin{array}{l} / \\ \backslash \end{array} \right.$	Retarding influence of anterior two or four thoracic segments (2).

The superficiality of the attempted explanation of the data is very apparent, but it is from this point of view that the analysis of the problems must be attacked. That the factors which it is attempted to isolate are real factors in normal development is shown by the physiological reversal of the opercula which takes place in the ontogeny of Hydroides, a process in all ways similar to the reversal after artificial section of the stalk of the functional operculum. From such a point of view the present analysis may be of value as affording a basis for further experimentation on the isolation of the factors involved in regulation.

Hull Zoölogical Laboratory,  
 University of Chicago,  
 May 17, 1904.

## LITERATURE CITED.

- AGASSIZ, ALEX., '66.—On the Young Stages of a Few Annelids. *Ann. Lyc. N. H. N. Y.*, vol. viii, pp. 303-343.
- BRUES; C. T., '03.—Reference in Wilson, E. B., '03.
- '04.—*Biol. Bulletin*, vol. vi, No. 6, May, 1904, p. 319.
- CAULLERY ET MESNIL, '97.—Études sur la morphologie comparée et la phylogénie des species chez les Spirorbes. *Bull. Scient., France, Belg.*, t. 30, pp. 185-233.
- '97.—Sur les Spirorbis; asymétrie de ces Annelides et enchainement phylogénique du genre. *Compt. Rend.*, t. 124, pp. 48-50.
- CLAPAREDE AND MECZNIKOW, '69.—Beiträge zur Erkenntnis der Entwicklungsgeschichte der Chætopoden. *Zeit. wiss. Zool.*, Bd. 19, pp. 163-205.
- GIARD, A., '76.—Note sur l'embryogénie de la *Salmacina Dysteri* Huxley. *Compt. Rend.*, t. 82, pp. 233-235 et 285-288.
- GRUBE, ED., '40.—Actinien, Echinodermen und Würme des Adriatischen u. Mittelm. *Königsb.*, p. 64.
- GRUBE, ED., '62.—Mittheilungen über die Serpulen mit besonderer Berücksichtigung ihrer Deckel. *Breslau. Sitzung der Schlesischen Gesellschaft für vaterlandische Kultur am 19 Juni*, '61.
- '78.—*Annulata Semperiana*. *Mem. de l'Acad. des Sc. de St. Petersburg*, p. 279.
- HASWELL, W. A., '85.—The Marine Annelids of the Order Serpulea. Some Observations on their Anatomy, with the Characteristics of the Australian Species. *Proceedings of the Linnean Soc. of N. S. Wales*, vol. ix, part 3.
- LEIDY, J., '83.—*Manayunkia speciosa*. *Proceed. Acad. Nat. Sc. Philadelphia*, 1883, pp. 204-212.
- MEYER, ED., '88.—Studien über den Körperbau der Anneliden. IV. Die Körperform der Serpulaceen und Hermellen. *Mitth. aus der Zool. Stat. zu Neapel*, viii, Bd.
- MILNE-EDWARDS, M., '45.—Observations sur le développement des Annélides. *Annales des Sc. Nat. Troisième Serie. Tome troisième*.
- MORGAN, T. H., '02.—Experimental Studies of the Internal Factors of Regeneration in the Earthworm. *Archiv. f. Entwicklungsmech. d. Organismen*, xiv, Bd. 3 u. 4 Heft.
- '04.—Notes on Regeneration. *Biol. Bull.*, vol. vi, No. 4. V. Transpositional or Compensatory Regeneration of the Chelæ in some Crustacea.

- MÜLLER, FRITZ, '64.—Für Darwin, pp. 76–77.
- ÖRLEY, L., '84.—Die Kiemen der Serpulaceen und ihre morphologische Bedeutung. Mitth. aus der Zool. Station zu Neapel, 5 Bd. s. 197.
- PAGENSTECHER, A., '63.—Untersuchungen über niedere Seethiere aus Cete. VII. Entwicklungsgeschichte und Brutpflege von *Spirorbis spirillum*. Zeit. wiss. Zool., 12 Bd., pp. 486–495.
- PRZIBRAM, H., '01.—Experimentelle Studien über Regeneration. Archiv. f. Entwicklungsmech. d. Organismen, Bd. 11.
- '02.—Experimentelle Studien über Regeneration. Zweite Mittheilung. Crustaceen. Archiv. f. Entwicklungsmech. der Organismen, Bd. 13, Heft 4.
- ROULE, L., '85.—Notes embryogéniques. Esquisses du développement de la *Dasychone lucullana*, D. Ch. Revue Sc. N. Montpellier (3), tome 4, p. 463–470.
- SALENSKY, W., '83.—Études sur le développement des Annélides. Première partie. No. 3. *Pileolaria*. Arch. Biol., tome 4, p. 143.
- DE ST. JOSEPH, X., '94.—Les Annélides Polychetes des Côtes de Dénard. Serpuliens. Annales des Sc. Nat. Zool., vii serie, t. xvii.
- '98.—Les Annélides Polychetes des Côtes de France. Ann. des Sc. Naturelles. Zool., viii serie, t. v, p. 209.
- WILLEMOES-SUHM, R. v., '71.—Biologische Beobachtungen über niedere Meeres-thiere. Zeit. wiss. Zool., 21 Bd., pp. 380–396.
- WILSON, E. B., '03.—Notes on the Reversal of Asymmetry in the Regeneration of the Chelæ in *Alpheus heterochelis*. Biol. Bulletin, vol. iv, 1902–03.
- ZELÉNY, C., '02.—A Case of Compensatory Regulation in the Regeneration of *Hydroides dianthus*. Archiv. für Entwicklungsmechanik der Organismen., xiii, Bd. 4 Heft.
- '03.—The Dimensional Relations of the Members of Compound Leaves. Bull. of the N. Y. Botanical Garden, vol. iii, No. 9.
- '03.—A Study of the Rate of Regeneration of the Arms in the Brittle-star, *Ophioglypha lacertosa*. Biol. Bull., vol. vi, No. 1.

## PHOSPHORESCENCE IN CTENOPHORES.

BY

AMOS W. PETERS.

### I. INTRODUCTION.

The problems discussed in this paper are the localization of the power of phosphorescence in mature and in young ctenophores, and the influence of certain factors, such as mechanical stimulation, light, and heat, upon the ability of these animals to phosphoresce.

The species upon which I have worked is the common summer ctenophore, *Mnemiopsis leidyi* A. Agassiz. These animals were to be found at Wood's Hole, Mass., abundantly during August, 1902 and 1903. The phenomenon of phosphorescence which they exhibited in their native sea-water when mechanically agitated after dark was suggestive of laboratory experiments.

In my experiments I found it necessary to use a dark chamber, which I constructed from a simple pine box heavily covered first with paper and then with several layers of black cloth. The dark box was placed upon a table before the experimenter and its open front was provided with overhanging cloth, sufficient to include his head and shoulders. This arrangement permitted both the observation of phosphorescence and the free use of the experimenter's hands for agitating the ctenophores, etc. This apparatus was not quite as efficient as a dark room, yet it was adequate for the work that was attempted in it. As observation of the animals required the continuous attention of the experimenter in the dark-box and as light must be excluded, the time was read and recorded by an assistant upon signals from the experimenter. This procedure also favored the adjustment of the experimenter's eye to the conditions of observation after the change from daylight to darkness. The time here recorded was read to tenths of a minute, and differences so small as this are nowhere of conse-

quence in the following work. The abundance of the material made it possible to select animals of the same large size for most of the experiments. Lots of from four to eight were placed in glass or porcelain dishes containing about one liter of sea-water brought in with the animals. In these dishes most of the tests for phosphorescence were made.

Several methods of mechanical stimulation, to be used in testing the animals for phosphorescence, were tried and compared. The most efficient of these was stirring the ctenophores by means of a glass rod. Simple contact with the rod frequently succeeded in bringing forth the response of phosphorescence when jarring, shaking, etc., failed. The adult animals being of sufficient size and weight, the contact of the glass rod with them was easily perceptible through the skin and muscles of the experimenter in the dark. This method of stimulation was uniformly adopted as a standard in this work, being also used for small parts of animals, embryos, and eggs. Unless a statement to the contrary is made, a fresh, previously unused lot of ctenophores was used in each test.

Strict uniformity of conditions and the constant presence of control animals excluded from the observations here recorded, it is hoped, errors arising from insufficient adjustment of the eye as well as from other sources. That these experiments could profitably be repeated and extended with a much greater degree of refinement, is a point the writer desires to emphasize.

He wishes to express here his indebtedness to Dr. G. H. Parker, of Harvard University, for critical advice and suggestion, and for the revision of the manuscript. He is also under obligation to the Humboldt Fund of the Museum of Comparative Zoölogy at Harvard College for financial assistance. Furthermore, his thanks are due to the authorities of the United States Fish Commission for the use of its laboratory at Wood's Hole, Mass., during the summers of 1902 and 1903.

## II. LOCALIZATION OF PHOSPHORESCENCE.

### I. *In Mature Animals.*

As is well known, ctenophores brought into the laboratory disintegrate quite readily. The dead substance of such animals was frequently tested both in the dark-box and in the dark-room.



In no case was any phosphorescence detected in the dead matter originating from ctenophores.

It was observed that after rough weather many ctenophores were mutilated but nevertheless phosphorescent. Even separated portions of the animal show this reaction both in the sea and in the laboratory. Such pieces examined under the magnifier always showed movements of the paddle plates and frequently muscular contraction. In short, the pieces of the animal were found to be alive. All the observations made gave the result that only the living ctenophores or living parts of them phosphoresce.

When either whole ctenophores of small size, or, much better, excised parts from various regions of the animal were examined under the magnifier in the dark, phosphorescence seems to be present only along the rows of paddle plates. When the paddle plates were numerous upon the excised piece, adjacent parts were often so illuminated as to make this determination uncertain. But when portions of the jelly entirely free from paddle plates were examined no phosphorescence was seen. Such jelly was alive, for when the same preparation was examined in the daylight muscular contraction could be seen in it. In the course of these experiments no phosphorescence could be obtained from jelly free from paddle plates.

The smallest piece from which phosphorescence was obtained consisted of four connected paddle plates with, of course, some jelly adhering. Even single excised paddle plates were observed to live for many hours or a day, as judged by their motion, and yet all efforts to get phosphorescence from single excised paddle plates were unsuccessful.

The excised auricles showed, under the magnifier, cilia but no paddle plates. No phosphorescence was obtained from them.

The sense organ with adjacent parts was excised in a piece about two centimeters long and one centimeter broad. Under the magnifier no paddle plates were seen, but muscular contraction was evident. No phosphorescence could be obtained from such a piece.

The previously described experiments with excised rows of paddle plates, or parts of them, are sufficient to show that phosphorescence does not depend upon correlation of the part with the sense organ. Whether cut in two transversely, or longitudinally in such a manner as to leave the sense organ wholly in one part,

the result was the same. In both cases the piece without the sense organ, as well as that with it, was phosphorescent.

If the whole animal had been made phosphorescent in the dark-box before the operation, both pieces retained phosphorescence; if the whole animal was originally non-phosphorescent, the pieces acquired this property in the dark-box.

Numerous tests were made to determine whether after transverse or longitudinal division the piece retaining the sense organ acquired phosphorescence sooner or later than the other piece. A normal animal, as a check, was subjected to the same test at the same time. The results seemed to follow the law of chance. Sometimes the piece with the sense organ phosphoresced more quickly than the other, sometimes more slowly. The results were hence negative and warrant the statement that the sense organ is not a controlling center for phosphorescence.

It was now clear that phosphorescence was localized somewhere in or near the paddle plates, and that the reaction-chain from stimulation to response consists very probably of an anatomically short and entirely local series of elements, *i. e.*, there is no distant central station for the reception, modification, or dispatch of impulses. Although it was shown that phosphorescence bears a local relation to the paddle plates the question was still open whether any necessary relation existed.

The attempt was therefore made to ascertain by experiment whether all movement of the paddle plates are accompanied with phosphorescence. A glass evaporating dish eight inches in diameter and three inches in depth was filled with sea-water to within half an inch of the top. At night a single medium-sized and strongly phosphorescent ctenophore was placed in the dish in the dark-room. The whole was left undisturbed for some time to insure the absence of currents originating from external mechanical disturbance of the dish. At intervals the dark-room was sufficiently illuminated to enable the observer to note the position of the animal in the dish. During the dark periods the attention of the experimenter was directed upon the dish for the purpose of observing phosphorescence, if any occurred. The result was that though the ctenophore was almost constantly changing position, sometimes to the extent of half the diameter of the dish, yet it showed no phosphorescence during the great majority of the dark intervals. Evidently during such intervals the paddle plates are

in motion and yet without being accompanied by phosphorescence. When in a dark period phosphorescence was seen, the light was immediately turned on, and it was observed that the ctenophore was adjacent to the side of the dish and had probably struck it in the course of locomotion. A slight mechanical stimulus, such as touching the animal with a glass rod, jarring the dish, or the table upon which it was placed, easily elicited the response of phosphorescence, both before and after the experiment described above. It was clear that the animal was capable of phosphorescence during all the periods of locomotion, but the necessary mechanical stimulus was absent except when the ctenophore came into contact with the side of the dish.

## 2. *In Embryos.*

Further observations were directed toward finding how far back in the ontogeny of the animal phosphorescence could be traced. The eggs were obtained as follows: On August 6, some ctenophores were brought into the laboratory and placed in glass evaporating dishes each containing about two liters of the sea-water brought in with them. Two animals were placed in each dish. The water was changed once or twice, only such being used as was brought directly from the sea. On the morning of August 7, a layer of eggs in various stages of development was found upon the bottom of each dish. By withdrawing the sea-water above them and replacing it with fresh sea-water about twice a day, they were reared to fully formed young ctenophores. In no instance were eggs observed to be deposited in the day time.

When a lot of eggs had developed to the stage in which the four sets of paddle plates first appear, phosphorescence could be demonstrated. If at night the embryos were stirred with a glass rod, or the dish containing them was jarred, numerous phosphorescent specks would appear momentarily. The experiment did not easily succeed in the day time, even if the eggs were kept in the dark-room. Perhaps the same rhythm in the intensity of phosphorescence belongs to them as to the adults. In the latter it was observed (1903) that phosphorescence was more intense and more easily excited at night than during the daytime, even when the animals were kept continuously in the dark-room. Furthermore, the phosphorescence of these embryos could not be indefinitely repeated, but was exhausted after a few flashes. In

this respect also they resemble the adults, except that exhaustion is much more quickly produced.

Experiments were made to test for phosphorescence before the formation of the paddle plates. A single gastrula was isolated at night in a watch glass. It was still contained in the egg-capsule and showed ciliary movement but no paddle plates were as yet developed. It was placed in the dark-room and, to make the conditions as favorable for the reaction as possible, it was allowed to remain undisturbed for half an hour, when the watch glass was suddenly jarred and a flash resulted. Another flash could not be obtained until after a period of rest.

Experiments were next made to test for phosphorescence in the segmentation stages and in the egg. It had been several times observed during these studies that embryos from animals that had been kept in the dark-room during the previous day were further advanced when examined the next morning than the embryos from animals kept in diffuse daylight during the previous day. Both lots originated from the same collection and were parallel in conditions except with regard to light. In this experiment the influence of light upon the time of egg laying was also tested.

August 11, 1903, 2 p. m. Collected *Mnemiopsis*. Distributed them into lots A and B, each consisting of several dishes. A was kept in the dark-room. B remained in diffuse daylight, later in artificial light, electricity and gas.

10 p. m. No eggs.

11.15 p. m. Eggs present in lot A of the dark-room. No eggs in lot B.

A number of eggs were immediately isolated in a solid watch glass and tested by stirring with a glass rod and by jarring, at intervals, in the dark-room. They were examined before and after the series of tests and were found to consist of one-cell stages. No phosphorescence could be detected in these undivided eggs.

August 12, 12.20 a. m. Cleavage stages from lot A were isolated in a solid watch glass. Examination before and after the tests showed that no ciliated (moving) embryo was as yet formed. Stages from one to thirty-two cells were present. After an undisturbed period in the dark-room stirring with a glass rod elicited phosphorescent flashes, but probably not from all the embryos.

12.45 a. m. No eggs in lot B.

1.20 a. m. Many embryos in lot A were becoming gastrulæ. Also many undeveloped (dead?) one-cell stages were still present in lot A.

1.30 a. m. No eggs in lot B.

2.20 a. m. Some eggs in lot B. Some of these were isolated in solid watch glasses, examined before and after testing for phosphorescence and found to be in one-cell stages.

2.40 a. m. No phosphorescence was detected in the one-cell stage isolated above from lot B.

An interesting result of this experiment is the difference of about three hours in the time of the laying of the eggs between lots A and B; lot A having been in the dark longer, deposited eggs sooner. In a subsequent experiment it was observed that animals kept in the dark from 9 a. m. had not yet deposited eggs at 10.30 p. m., although eggs were present the next morning. Hence the deposition of eggs does not seem to occur after simply a given number of hours of darkness. The indications favor the view that the deposition of eggs takes place in accordance with the daily rhythm of light and darkness, deposition occurring in the dark period, and being capable of retardation by light.

### III. INFLUENCE OF CERTAIN FACTORS ON PHOSPHORESCENCE.

#### I. *Agitation and Light.*

In determining what factors influence phosphorescence it has been found convenient to deal with agitation and light together. Preliminary tests showed that ctenophores removed to the dark-box at once from their native sea-water, where they had been exposed to direct sunlight, were not immediately phosphorescent. However, they became so after remaining in the dark for some time. Similar observations were first made on Beroë by Allman ('62) and subsequently by Panceri ('72). The above fact was the starting point for a series of experiments in which both light and agitation were factors.

*Experiment I.* Lots A and B having been exposed to direct sunlight for about one hour, were both placed in the dark-box at the same time. The ctenophores in A were then continually agitated with a glass rod, while B was left undisturbed except for momentary tests made at intervals. A phosphoresced first in 2.5 minutes; B in 3.0 minutes.

The result shows that direct sunlight prevents the occurrence of phosphorescence and that mechanical stimulation accelerates it.

*Experiment 2.* Two phosphorescent lots, A and B, were exposed to direct sunlight for three minutes. They were then both placed in the dark-box at the same time. They were both found to be non-phosphorescent. A was then continuously agitated and B was left undisturbed except for tests, as above described. A phosphoresced first in 2.5 minutes; B in 3.0 minutes.

After permitting the phosphorescence to develop for a minute or two, A was exposed to direct sunlight for two minutes while B remained in diffuse daylight. A was continually agitated in the dark-box as above described. A phosphoresced first in 1 minute; B continued to phosphoresce.

After some minutes both were exposed to diffuse daylight and then tested as follows: A was agitated in the dark-box, while B remained undisturbed. A first phosphoresced in 1 minute; B in 2 minutes.

The result indicates that exposure to direct sunlight not only prevents phosphorescence, as found in the preceding experiment, but also overcomes a previously acquired power to phosphoresce. Furthermore mechanical stimulation, as before, accelerates the appearance of phosphorescence.

*Experiment 3.* It was observed that Mnemiopsis was sometimes phosphorescent and sometimes not so after standing for a time in the diffuse daylight of the laboratory. The object of this experiment was to test the power of diffuse daylight, of the intensity then prevailing in the laboratory, to inhibit or permit phosphorescence, as well as to test further the influence of mechanical stimulation. The ctenophores used had been exposed to diffuse daylight. A was agitated in the dark-box, but B, in the same box, was undisturbed except for tests. Both A and B were then again exposed to diffuse daylight. A was then put in the dark-box and agitated; B was undisturbed except for tests. A phosphoresced first in 1.7 minutes; B in 2.5 minutes.

The results show that diffuse daylight can check phosphorescence and, as before, mechanical stimulation can accelerate its appearance.

*Experiment 4.* In this experiment ctenophores in the dark-box were continuously agitated with a glass rod to determine whether

the phosphorescent condition could be removed by excessive mechanical agitation. Reduction of intensity had frequently been observed after long continued agitation.

2.22 p. m. Strong phosphorescence.

2.42 p. m. Phosphorescence appears only in slight gleams, but these persist upon stimulation with the glass rod.

The result indicates that sufficiently long-continued agitation reduces the intensity of phosphorescence, but does not entirely inhibit it.

*Experiment 5.* The object of this experiment was to determine whether the rate at which the ability to phosphoresce is acquired, varies with the intensity of the light. Lots A and B each with six ctenophores, were exposed to direct sunlight for five minutes. The temperature of the sea-water before the exposure was  $21^{\circ}.5$  C.; after it,  $22^{\circ}.5$  C. Then A was kept in the dark-box until phosphorescent, being tested at intervals (*i. e.*, not continuously agitated). During the same time B was exposed to diffuse daylight and at intervals it was placed in the dark-box for a momentary test. B did not phosphoresce during the whole experiment (19.5 minutes). A phosphoresced first after three minutes in the dark-box, and though kept in diffuse daylight, it retained its phosphorescence over five minutes, after which it lost its phosphorescence so long as it remained in the light.

The result indicates that the ability to phosphoresce is acquired more quickly in darkness than in diffuse daylight and also that phosphorescence has a proportionate relation, in a negative sense, to the intensity of the light.

*Experiment 6.* Preceding experiments have shown that: (1) darkness is at least one necessary condition for phosphorescence; (2) darkness alone does not result in phosphorescence; and (3) mechanical agitation can call forth and accelerate this phenomenon in the dark. This comparison suggested the question, Can agitation alone produce phosphorescence? To make this determination a lot of ctenophores were poured repeatedly from one dish to another in diffuse daylight and were tested at intervals in the dark-box. The agitation including the tests was continued for a period of ten minutes. No phosphorescence whatever could be detected. The inability of agitation to produce this phenomenon was frequently observed.

This result shows that a non-phosphorescent ctenophore is not made phosphorescent by mechanical agitation alone. Furthermore, comparison of all preceding experiments shows that darkness accompanied by mechanical stimulation is at least one combination of conditions which is able to produce phosphorescence, but its two factors acting singly cannot produce this result. Other stimuli capable of eliciting phosphorescence may, of course, exist.

## 2. *Temperature.*

*Experiment 1.* This experiment was made to determine the effects of physiological extremes of temperature. It was performed in a dark room. A pailful of fresh ctenophores standing there at a temperature of  $21^{\circ}.5$  C. emitted, when jarred, enough light to illuminate the room to a considerable degree. From this supply four animals (lot A) were removed to the ice bath and four others (lot B) to the warm-water bath. The respective cooling and warming of the two lots was done simultaneously. The ice bath consisted simply of a basin containing broken ice, in which the vessel containing lot A was partly immersed. Neither ice nor fresh water (from melting ice) came into contact with the animals. They were gradually cooled in their original sea-water. The other lot of animals (B) were warmed in sea-water by placing the vessel containing them over sufficiently warmed water. The tests for phosphorescence were made at intervals by stroking the ctenophores as usual with a glass rod. The temperatures were taken with the bulb of the thermometer in contact with the surface of the animal. Since the phosphorescent parts, the paddle plates, are superficial, the temperatures given apply to these parts. The interior of the jelly might have been at a different temperature. Under these conditions the following record was obtained:

Lot A at  $21^{\circ}.5$  C. was strongly phosphorescent; seven minutes later at  $12^{\circ}.5$  C. no phosphorescence could be observed. A was then removed to the warm-water bath whereupon the animals became, after some time, phosphorescent. Hence the previous cessation of phosphorescence was not due to death.

Lot B at  $21^{\circ}.5$  C. was also strongly phosphorescent; five minutes later at  $37^{\circ}$  C. no phosphorescence was observable.



Lot B was then removed to the ice bath whereupon the animal became, after some time, phosphorescent. Hence the previous cessation of phosphorescence was not due to death.

*Experiment 2.* The aim and methods of this experiment were the same as in Experiment 1.

Lot A at  $21^{\circ}.5$  C. was strongly phosphorescent; after 6.5 minutes cooling it was much diminished, and after 13.5 minutes ( $9^{\circ}$  C.) there was no phosphorescence. Lot A was then placed on the warm water-bath and in 13 minutes became again phosphorescent.

Lot B at  $21^{\circ}.5$  C. was strongly phosphorescent; after seven minutes warming the phosphorescence was much diminished, and after ten minutes ( $38^{\circ}$  C.) there was none. At this temperature the animals had completely disintegrated.

*Experiment 3.* The aim and methods of this experiment were the same as in Experiments 1 and 2.

Lot A, strongly phosphorescent at  $21^{\circ}.5$  C., was cooled in ten minutes to  $9^{\circ}.5$  C. and became non-phosphorescent.

Lot B, strongly phosphorescent at  $21^{\circ}.5$  C., was cooled in 12.5 minutes to  $11^{\circ}.5$  C. and became non-phosphorescent.

Another series of experiments was made to determine the effects of variations of a few degrees only from the normal. Such variations, of from one to four degrees above and below the normal ( $21^{\circ}.5$  C.), showed, in all the trials but one, a diminution of phosphorescence as compared with a control. In other words, phosphorescence in the dark-box appeared sooner in the animals at normal temperature than at any other temperature. It would not have been surprising to find an optimum point slightly different from the normal temperature. The experiments made upon this subject are not regarded as conclusive.

The general result of this work upon temperature may be stated as follows:

The phenomenon of phosphorescence in the ctenophores here investigated occurred during a range of temperature extending from about  $9^{\circ}$  C. to  $37^{\circ}$  C., with an optimum at or near  $21^{\circ}.5$  C., which was the temperature of their native sea-water. The intensity of phosphorescence diminishes as physiological extremes of temperature are approached.

## IV. DISCUSSION OF RESULTS.

The preceding experiments demonstrate that the power of phosphorescence is located in the mature animal solely in the region of the paddle plates. I am not aware of direct evidence for a more precise localization than that just given. Allman ('62, pp. 518-519) and Chun ('80, p. 195) attributed this phenomenon in *Beroë* to the germinal cells lying in the walls of the gastro-vascular tubes. The supposed fatty, phosphorescent substance of *Panceri* according to Chun ('80, p. 195) does not exist. Phosphorescence was observed by A. Agassiz ('74, p. 371) in embryos.

The experiments described in this paper also show that this property belongs to protoplasm that has but little organic differentiation, viz: that of the earlier stages of segmentation. When we inquire what service in the economy of the animal is rendered in the process of phosphorescence we find it difficult to give a satisfactory reply. I have never been able to obtain phosphorescence in mature ctenophores without the motor activity of the paddle plates, but not every movement of these is accompanied by phosphorescence. Darkness and mechanical agitation are the two selective stimuli whose joint presence results in phosphorescence. This important fact, taken in connection with the localization of the reaction, the acceleration of its appearance by mechanical agitation, and its complete inhibition by extremes of temperature, lead to a probable conclusion regarding its nature. The phosphorescence of *Mnemiopsis* is a metabolic reaction which is dependent upon the formation of a substance in darkness, the katabolism of which takes place upon mechanical stimulation and becomes observable as the energy of light. The amount of substance so accumulated may be exhausted by continued mechanical stimulation in darkness or may be consumed as produced. When the animal is brought into the light the substance is no longer produced or, if so, it undergoes katabolic transformation rapidly, or the energy is given out in some other form than light. That the phosphorescent substance cannot accumulate in the light is shown by the fact that ctenophores removed from bright daylight or sunlight to darkness are not immediately phosphorescent. This is the case whether they have been previously agitated or have remained undisturbed.

SUMMARY.

1. The dead matter originating from ctenophores is not phosphorescent, *i. e.*, only living ctenophores or parts of them phosphoresce.

2. Phosphorescence appears along the rows of paddle plates and no phosphorescence was obtained from jelly free from paddle plates.

3. The smallest piece from which phosphorescence was obtained consisted of four connected paddle plates.

4. Movement of the paddle plates is not always accompanied by phosphorescence.

5. No phosphorescence was obtained from the excised auricles having cilia but no paddle plates.

6. The sense-organ is not phosphorescent.

7. Phosphorescence does not depend upon correlation of the part with the sense organ. The sensory-motor circuits for phosphorescence are local in character.

8. No phosphorescence could be obtained from the eggs of *Mnemiopsis* before segmentation.

9. The early cleavage stages (without cilia) are phosphorescent.

10. Gastrulæ (ciliated) are phosphorescent, as are also all stages in which paddle plates are present.

11. The phosphorescence of embryos is easily exhausted.

12. The deposition of eggs can be retarded by light.

13. Direct sunlight prevents the appearance of phosphorescence, but in darkness, the power to phosphoresce upon stimulation, is acquired.

14. Direct sunlight inhibits a previously acquired power to phosphoresce. Diffuse daylight of sufficient intensity has the same effect.

15. Phosphorescence has a proportionate relation, in a negative sense, to the intensity of light.

16. Mechanical stimulation accelerates the appearance of phosphorescence in darkness.

17. Non-phosphorescent ctenophores do not become phosphorescent by mechanical agitation alone.

18. Long-continued mechanical stimulation reduces the intensity of phosphorescence but does not easily inhibit the phenomenon entirely.

19. Darkness accompanied by mechanical stimulation is at least one combination of conditions which produces phosphorescence, but these two factors acting singly cannot produce this result.

20. The phenomenon of phosphorescence was observed at temperatures ranging from about  $9^{\circ}$  C. to  $37^{\circ}$  C., with an optimum at or near  $21^{\circ}.5$  C., the temperature of the sea-water.

21. The intensity of phosphorescence diminishes as physiological extremes of temperature are approached.

22. The phosphorescence of *Mnemiopsis* is probably a metabolic reaction which is dependent upon the formation of a substance in darkness the katabolism of which takes place upon mechanical stimulation and becomes evident to observation as the energy of light.

#### BIBLIOGRAPHY.

- AGASSIZ, A., '74.—Embryology of the Ctenophoræ. Mem. Amer. Acad. Arts and Sci., vol. x, pt. 2, no. 3, pp. 357-398, 5 pl.
- ALLMAN, G. J., '62.—Note on the Phosphorescence of *Beroë*. Proceed. Roy. Soc. Edinburgh, vol. iv, no. 57, pp. 518-519.
- CHUN, C., '80.—Die Ctenophoren des Golfes von Neapel und der angrenzenden Meeres-abschnitte. Fauna und Flora des Golfes von Neapel. Monographie 1. xvii + 313 pp., 18 Taf.
- PANCERI, P., '72.—La luce e gli organi luminosi dei *Beroidei*. Atti R. Accad. Sci. fis. e mat. Napoli, vol. v, no. 20, 15 pp., 1 tav.

# A STUDY OF THE INHERITANCE OF DICHROMATISM IN *LINA LAPPONICA*.

BY

ISABEL McCracken.

*Stanford University, California.*

WITH 1 PLATE AND 3 FIGURES IN THE TEXT.

## I. INTRODUCTION.

This paper contains a statement of breeding experiments with a certain species of leaf-beetle, *Lina lapponica*, which have been carried on this year (1904) in the Entomological Laboratory of Stanford University.

*Lina lapponica* is a small beetle of the family Chrysomelidæ. Both larvæ and adults feed from early spring until late in the fall on willow or poplar leaves. The females are, for the most part, considerably larger than the males, although intergrading sizes occur.

The thoracic length of the smallest males is about 1.5 mm., abdominal length 6 mm., thoracic width 2.5 mm., abdominal width about 4 mm. Thoracic length of the largest females is about 2 mm., thoracic width 3 mm., abdominal length 7 mm., abdominal width 5 mm. The wing covers in both males and females may be entirely black, (Pl. 1, Fig. 6), or brown with fourteen black spots (Pl. 1, Fig. 4). The eggs are elongate, yellowish, and laid side by side upon the leaves of the plant furnishing food for both larvæ and adults. The life of each individual, in the early generations of the season, occupies from three to six days in the egg stage, from fifteen to twenty days (with two moults) in the larval stage, and from four to eight days in the pupal stage. The adult stage varies from twenty to thirty days. The adult stage of later generations is of longer duration. Each female produces from four to six broods a season, each brood containing from thirty to forty individuals. The number of generations in a year under normal

outdoor conditions is unknown, but under laboratory conditions at least five generations may be secured.

The object of the present experiment was to observe through several generations the behavior of the particular differentiating character, *color*, with the view of testing for this insect Mendel's principles of dominance and segregation.

The particular circumstances that make *Lina lapponica* favorable material for this study are these:

1. Both sexes are dichromatic.
2. The sexes are easily distinguished on account of the difference in size.
3. Individuals may be mated for life, or males of one brood may be allowed to mate freely with females of another, thus securing diversity of partners (the plan without doubt pursued in nature), while securing the same lineal record for the offspring.
4. Life habits are adapted to laboratory conditions.
5. At least five (probably more) generations may be reared in a single season.

This work was not begun until the first generation of *Lina* for the present year had come to maturity. However, the four succeeding generations studied offer some interesting and instructive data that will be supplemented another year when an earlier brood will be secured.

## II. CHARACTER OF THE MATERIAL USED IN THE EXPERIMENTS.

For the initial study, about 1000 individuals in the last larval stage were collected from willows between April 20 and May 4, 1904. From these a total of 600 adults were secured, the rest having fallen prey to a parasitic fly. This lot contained a representative number of males and females, and the dichromatic extremes of color.

Individuals in one of the two color and pattern series have, as previously stated, wing covers with ground work of brown, dotted with fourteen black spots (Pl. 1, Fig. 4). There is considerable variation in shape, size and coalescence of spots, but no apparent variation in ground color. Individuals representing this color type are referred to in this paper as S. In the other series the individuals are wholly melanic or black (Pl. 1, Fig. 6). These are here referred to as B. In each series the thorax is similar,

having a median dorsal area of black covering one-half of the dorsal surface, and marginal areas that are white when the insect first emerges, and turn a copper-red about six days later. A single black spot is present within each marginal area.

For the purposes of this year's study no account was taken of the variation within each series, namely, the fluctuating variations, and their behavior in heredity, as this demands a special series of experiments.

I began the present series of experiments with the notion that the melanic variety was the possible result of a coalescence of all the spots in the spotted variety. A study of the color development at ecdysis, however, revealed the fact that the dark pigment giving the melanic series its color is superimposed on the spotted condition. The wing covers of an adult that has just slipped out of its pupal case are at first white (Pl. 1, Fig. 1). Within a few minutes the spotted areas, first the anterior, then the middle, and lastly the posterior are dimly but distinctly indicated as light drab color against the white background (Pl. 1, Fig. 2). The spots deepen gradually to a dark drab, and the ground color becomes a light drab (Pl. 1, Fig. 3). In the melanic series these two steps, namely, pigmentation of the spotted areas and pigmentation of the rest of the wing cover, occasionally take place almost simultaneously, the spotted areas then becoming so obscured as not to be apparent. Their presence in every doubtful case, however, was determined by holding the wing cover between the light and the observer. From the drab stage development proceeds in one of two directions. In one series of individuals, including both males and females the spots deepen to black, and following quickly upon this change, the drab ground color gives way to brown pigment against which the fourteen black spots are clearly marked (Pl. 1, Fig. 4). In the other series, the spots as before deepen to black, and the drab gives way to black pigment (Pl. 1, Fig. 5). This soon overshadows and totally obscures the spots from surface view (Pl. 1, Fig. 6). Their presence may still be demonstrated, however, by holding the wing to the light.

It appears, therefore, that in *Lina lapponica* we have to deal in its dichromatism with a case of "substantive discontinuous<sup>1</sup> variation." Each individual is either melanic, B, or not melanic, S, all individuals alike being spotted.

<sup>1</sup>Bateson: "Materials for the Study of Variation."

The question arises, "How do these extremes of color and pattern behave in heredity?" Having no known pure bred stock to begin with, my first attempt was to breed out by selection the alternative color from each of the two extreme lines. Succeeding in this, I hoped to have on hand material for testing the validity of Mendel's laws of "dominance and segregation" for this species. In pursuance of this the following breeding experiments were devised and carried out, and the results recorded in detail. In the succeeding tables summaries only are given.

### III. METHOD OF EXPERIMENTATION AND RESULTS.

Experiment 1. To determine relation of first generation from laboratory reared adults to the color types S and B. (Table I.)

Experiment 2. To determine relation of second generation bred from similars to color types S and B. (Tables II and III.)

Experiment 3. To determine relation of individuals bred for two generations from similars to the color types S and B. (Tables IV and V.)

Experiment 4. To determine relation of offspring of extremes, having on each side pure heredity for at least a generation to the color types S and B. (Tables VI, VII and VIII.)

Experiment 5. To determine in what generation from mixed parentage the alternative characters breed pure. (Tables IX and X.)

*Experiment I.* The generation with which this work was begun was collected in last larval instar from willow trees in a certain locality in the neighborhood of Stanford. These were caged in the laboratory, and thereafter fed upon poplar and willow leaves until pupation. As soon after emerging as the wing color was established, namely, in about an hour, the adults were placed in one of four breeding cages as follows:

- Cage 1. Black ♂'s and black ♀'s only.
- Cage 2. Spotted ♂'s and spotted ♀'s only.
- Cage 3. Black ♂'s and spotted ♀'s only.
- Cage 4. Spotted ♂'s and black ♀'s only.

Sex was determined by size. Individuals not exhibiting extremes of size, namely, individuals not easily distinguished as to



sex were discarded. By this means individuals were limited to mates of a definite color without forced mating. A pair once mated, however, were mated for life, as they were then removed to a 1 x 4 inch shell vial and numbered. Here they lived and reproduced for the rest of their lives.

Each mass of eggs oviposited was removed to a 12 ounce breeding jar for further development, and given its parental number. In this way 288 individuals were mated, representing 144 crosses. Of these, ten pairs produced no eggs, although copulation took place several times, nineteen pairs produced eggs that failed to develop, nine pairs produced eggs that went through pre-embryonic development, but failed to hatch, and 106 pairs produced eggs that hatched in from three to six days, the offspring reaching maturity in about twenty-five days from the date of hatching. The 106 pairs represented the following matings:

57 pairs of S ♂ × S ♀  
 19 pairs of B ♂ × B ♀  
 14 pairs of B ♂ × S ♀  
 16 pairs of S ♂ × B ♀

Table I, compiled from the records of individual broods, gives a summary of the data obtained.

We find, therefore, that in a lot of 57 ♂ S's mated with a lot of 57 ♀ S's without respect to ancestry, that over one-half reproduce their kind, while the others produce mixed broods (32 : 25). The mixed broods are made up of individuals representing the extremes of color only—no blends—in the proportion 890 S : 280 B, or 3.2 S : 1 B.

Also in a lot of 19 ♂ B's and 19 ♀ B's, the parents chosen at random without respect to ancestry, two sorts of broods are produced, namely, broods true to parent color and mixed broods, in the proportion 14 pure : 5 mixed. The mixed broods are made up of individuals representing the extremes of color only, in the proportion 1 S : 1.7 B.

Therefore, from parents chosen at random, but similarly mated, two sorts of broods are obtained, broods true to parental type, or pure broods, and mixed broods, the preponderance of individuals being in each case on the side of the color type of the immediate parents. Records of individual broods show that this condition

TABLE I.

Color Character of Matings.	Total Number of Mating Pairs.	Total Number of Broods Obtained.	Average Number in a Brood.	Total Number Individuals Reared to Maturity.	Total Number Pairs Producing Broods True to Parental Color.	Total Number of Individuals True to Parental Color.
a S♂ × S ♀	57	114	32 -	3625	32	2455
b B♂ × B ♀	19	39	30	1188	14	1029
c S♂ × B ♀	16	35	30	1049	2	0
d B♂ × S ♀	14	29	31	910	1	0
Total . .	106	217	—	6872	—	—

Color Character of Matings.	Number of Pairs Producing Mixed Broods.	Total Number of B in Mixed Broods.	Total Number of S in Mixed Broods.	Per Cent of Pairs Producing Pure Broods.	Per Cent of Pairs Producing Mixed Broods.	Proportion of S : B in Mixed Broods.
a S♂ × S ♀	25	280	890	56+ %	44- %	3.2 - : 1
b B♂ × B ♀	5	100	59	73+ %	27- %	1 : 1.7+
				Total Number S in S Broods.	Total Number S Broods.	Total Number Mixed Broods.
c S♂ × B ♀	14	369	645	35	2	33
d B♂ × S ♀	13	341	559	10	1	28

obtains for the total number of offspring of each pair, as well as for the sum total in both series.

Dissimilar parents produced on the whole mixed broods with preponderance of individuals in the S color type. Records of individual broods show that that preponderance was maintained in every S ♂ × B ♀ cross but four, namely, in 12 out of 16

TABLE II—B × B. (See also Table VII.)

Broods Utilized (Note-book Numbers).	Number of Egg Masses Collected.	Offspring Reared to Maturity.		Total Offspring.	Color Character.	
		♂	♀		B.	S.
a 19♂ × 27♀	25	460	379	839	all	none
b 27♂ × 19♀	18	314	243	557	all	none
c 39♂ × 29♀	31	570	467	1037	all	none
d 29♂ × 39♀	24	376	348	724	all	none
e 39♂ × 40♀	3	59	41	100	all	none
f 40♂ × 39♀	5	88	83	171	all	none
g 110♂ × 55♀	7	120	111	231	all	none
h 55♂ × 110♀	21	299	281	580	all	none
i 62♂ × 59♀	1	14	20	34	all	none
j 59♂ × 62♀	22	373	339	712	all	none
Total	157	2673	2312	4985	all	none

crosses, and in every S ♀ × B ♂ cross but two, namely, in 12 out of 14 crosses.

*Experiment 2.* My next effort was to see if I could by selection bring the two differentiating characters to breed true in certain lineages. I, therefore, selected ten broods from among the pure broods (broods true to parents) produced by B × B and ten broods from among the pure broods produced by S × S. All the males of one brood were placed in a breeding jar with all the females of

another brood of the same type. Each mass of eggs oviposited was removed to a separate jar for development.

Tables II and III show the results in full. The numbers in the first column are simply my distinguishing numbers of broods utilized for the crossings. The second column represents, not the total number of egg masses produced, but the number of broods which the facilities for handling permitted me to rear.

TABLE III—S × S. (See also Table VI.)

Broods Utilized.	Number of Egg Masses Collected.	Number of Broods Produced True to Parents.	Number of Mixed Broods Produced.	Offspring Reared to Maturity.		Total Offspring.	Total Number Bred True to Parents.	Color Character of Mixed Broods.	
				♂	♀			B.	S.
<i>a</i> 30♂ × 79♀	4	0	4	93	72	165	0	46	119
<i>b</i> 79♂ × 30♀	6	2	4	123	93	216	70	27	119
<i>c</i> 119♂ × 129♀	4	1	3	91	51	142	31	21	90
<i>d</i> 129♂ × 119♀	5	3	2	112	68	180	91	25	64
<i>e</i> 144♂ × 134♀	8	8	0	150	115	265	265	0	0
<i>f</i> 134♂ × 144♀	6	6	0	104	78	182	182	0	0
<i>g</i> 32♂ × 73♀	19	9	10	409	274	683	321	78	284
<i>h</i> 73♂ × 32♀	19	10	9	411	273	684	343	95	246
<i>i</i> 112♂ × 119♀	3	2	1	63	31	94	61	5	28
<i>j</i> 119♂ × 112♀	14	11	3	245	172	417	298	48	71
Total.....	88	52	36	1801	1227	3028	1662	345	1021

In Table II we find a total of 4985 individuals, representing a total of 157 broods, all coming true to parents in the second generation, the grandparents having been selected at random, except for color type (*i. e.*, regardless of ancestry).

In Table III we find two matings, *e* and *f*, producing broods entirely like parents, but every other mating produced either mixed broods, or some pure and some mixed broods. If we leave out of consideration the evidently pure lineage-matings produced

by *e* and *f*, the proportion of the pure to the mixed broods, stands as 38 pure to 36 mixed in the aggregate, or, 51 + per cent : 49 - per cent, a relation not materially differing from that obtained in Table I from random matings within the color type S. In the mixed broods the aggregate proportion of S : B is 1021 : 345, or 2.98 S : 1 B. Table I shows the relation of S : B resulting from random S × S crossings to be 3.2 S : 1 B.

TABLE IV—B×B.

Broods Utilized (Note-book Numbers).	Number of Egg Masses Collected.	Number of Broods True to Parent Color.	Number of Mixed Broods.			Total.		
				♂	♀	B.	S.	
<i>a</i> 21♂×81♀	4	4	0	41	40	81	all	0
<i>b</i> 81♂×21♀	5	5	0	63	69	132	all	0
<i>c</i> 28♂×13♀	5	5	0	65	54	119	all	0
<i>d</i> 13♂×28♀	7	7	0	94	85	179	all	0
<i>e</i> 17♂×35♀	5	5	0	75	69	144	all	0
<i>f</i> 35♂×17♀	6	6	0	98	96	194	all	0
<i>g</i> 32♂×63♀	10	10	0	175	136	311	all	0
<i>h</i> 63♂×32♀	5	5	0	92	75	167	all	0
<i>i</i> 31♂×47♀	5	5	0	95	74	169	all	0
<i>j</i> 47♂×31♀	4	4	0	66	55	121	all	0
Total.....	56	56	—	864	753	1617	all	0

From a comparison of Tables II and III it follows, therefore, that here the differentiating color characters S and B follow different lines of behavior in heredity, B breeding pure in second generation from random parentage, and S continuing to breed some pure and some mixed broods in the second generation, following Mendelian expectations for recessives and dominants.

*Experiment 3.* In order to determine how the color types were inherited in the third generation (first generation bred from

similar of random selection, second bred from similars of pure selection) certain broods were chosen from those designated in Table II, for B  $\times$  B crossings, and in Table III, from broods true to parents for S  $\times$  S crossings. Males of one brood were allowed to breed freely with females of another brood as in previous experiments. Great mortality prevailed at this time, materially affecting the number of S broods available. Tables IV and V show results in the aggregate.

Table IV shows no reappearance of S in the fourth generation from B  $\times$  B.

TABLE V—S  $\times$  S.

Broods Utilized (Note-book Numbers.)	Number of Egg Masses Collected.	Number of Broods True to Parentage.	Number of Mixed Broods.			Total Number of Indi- viduals Reared.	B.	S.
				♂	♀			
a 7♂ $\times$ 39♀	6	6	o	99	63	162	o	all
b 39♂ $\times$ 7♀	4	4	o	83	52	135	o	all
c 8♂ $\times$ 24♀	5	5	o	92	76	168	o	all
d 24♂ $\times$ 8♀	4	4	o	83	60	143	o	all
Total . . .	19	19	—	357	251	608	o	all

The results in Table V while involving but four parental broods are consistent throughout, making it probable that B can be eliminated from the S  $\times$  S line in three generations of selective mating. Whether it would reappear later must be determined by future experiment.

The accompanying diagrams represent the ancestry of two third generation broods. The numbers used are the recorded numbers of certain individuals in Table I, and certain broods in other tables.

Fig. 1 shows that all the offspring reared through the third generation from the eight great-grandparents; that is, from 19 ♂, 19 ♀, 27 ♂, 27 ♀, 39 ♂, 39 ♀ and 29 ♂, 29 ♀ are B, and this

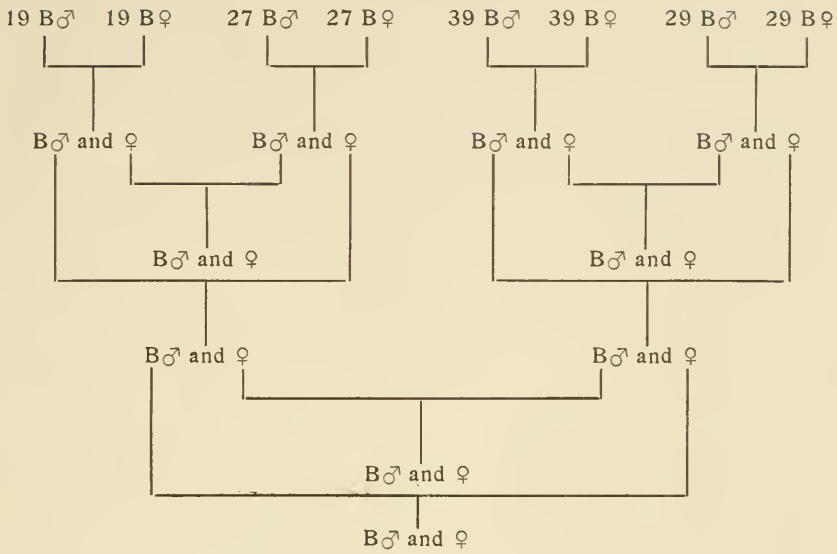

FIG. 1.

Diagram showing pedigree of certain B broods through three generations.

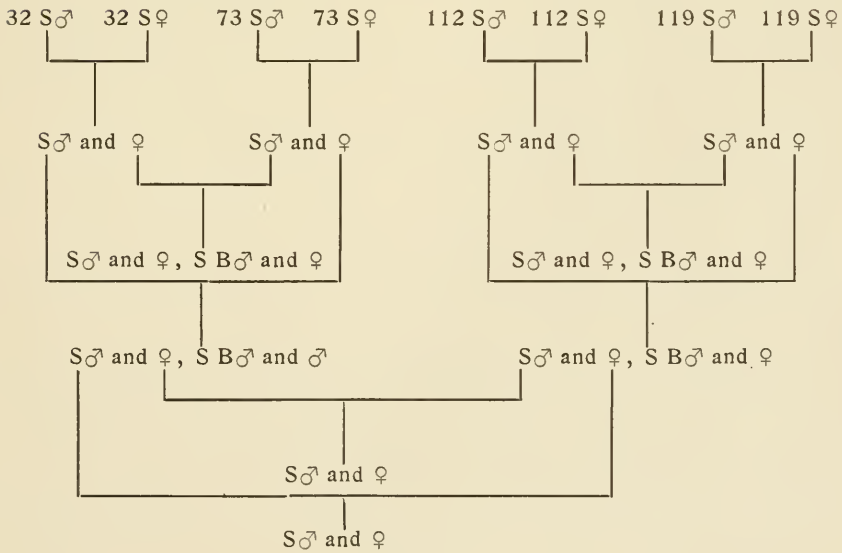

FIG. 2.

Diagram showing pedigree of certain S broods through three generations, the parents having been selected from pure S broods only, viz: broods from 7 S♂ × 39 S♀ and 39 S♂ × 7 S♀. See Table V, a and b.

diagram is characteristic of the pedigree of all of the fourth generation individuals specified under total in Table IV.

Fig. 2 shows, as previously stated, that in the first generation from  $S \times S$ , pure S broods only were obtained, in the second generation both pure and mixed broods were obtained (*i. e.*, S, and S and B), in the third generation pure S broods only.

*Experiment 4.* With second generation broods (first generation bred from known parents) some crosses were made between

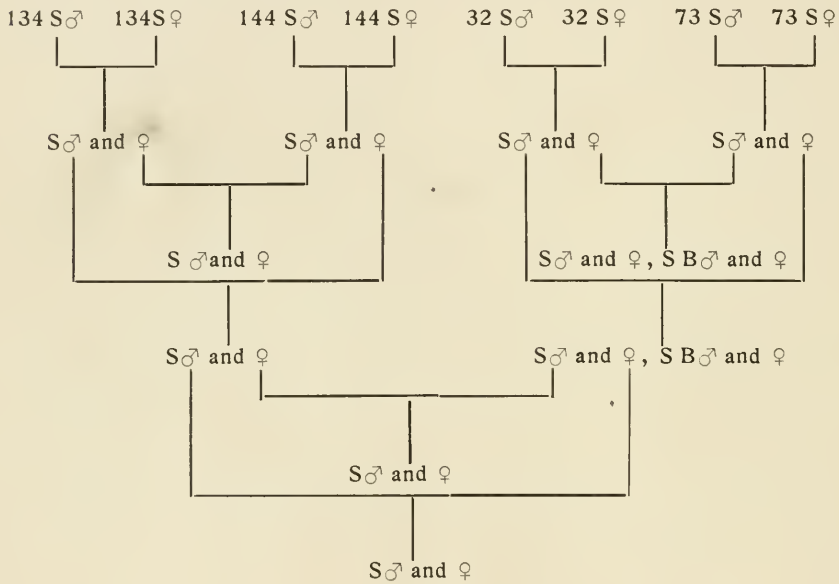

FIG. 3.

Diagram showing the pedigree of the broods recorded in Table V, *c* and *d*, namely, broods obtained from  $8 S \text{♂} \times 24 S \text{♀}$  and  $24 S \text{♀} \times 8 S \text{♂}$ .

extremes of color type to determine the relation the color types bore to each other in heredity in case each extreme was found to breed true to itself, in other words to test the validity of Mendel's law of dominance under these conditions.

Eight pure S broods and eight pure B broods were chosen from Table I, *a* and *b*, column 6. Each cross was between a half brood of B's and a half brood of S's. Table VIII shows the results of the reciprocal cross matings, and Tables VI and VII the results of control pure matings.



In Table VI we observe the progeny in matings *a* and *b* only breeding true to parentage. Consequently in Table VIII the only crosses answering to Mendelian conditions are crosses *a* and *b*, crosses between individuals of two differentiating characters S and B, each of which presumably breeds true to its kind. In the progeny of these crosses we observe typical Mendelian results, namely, each cross produces offspring like one parent only, the S parent, regardless of whether S is a male or a female character.

TABLE VI—S×S Parents. S×S Grandparents.

Broods Utilized.	Number of Egg Masses Collected.	Number of Broods True to Parents.	Number of Mixed Broods.	Number of Individuals.		Total Number of Individuals.	B.	S.
				♂	♀			
<i>a</i> 157♂×134♀	4	4	0	92	76	168	0	168
<i>b</i> 134♂×157♀	3	3	0	57	37	94	0	94
<i>c</i> 112♂×119♀	3	1	2	55	36	91	3	88
<i>d</i> 119♂×112♀	4	3	1	70	36	126	3	123
<i>e</i> 152♂×162♀	5	3	2	81	66	147	10	137
<i>f</i> 162♂×152♀	4	3	1	76	40	116	2	114
Total.....	23	17	6	431	311	742	18	724

While cross *b* gives a Mendelian result we cannot say that it entirely answers Mendelian conditions, since as shown in Table VI, *c* and *d*, S 112 may or may not have been a pure Mendelian dominant. If we interpret the results as typically Mendelian we must look upon S 119 in Table VI as representing hybrids and influencing the offspring in S 119 × S 112 crosses. The results of crossing S 119 × B 154, Table VIII, are in harmony with this interpretation.

Having no other pure S broods of similar ancestry than those of *a* and *b*, Table VIII, these broods were left unmated, and consequently the fate of the S and B characters is unknown; that is, as

TABLE VII—B×B Parents. B×B Grandparents.

Broods Utilized.	Number of Egg Masses Collected.	Number of Broods True to Parents.	Number of Mixed Broods.	Number of Individuals.		Total Number of Individuals.	B.	S.
				♂	♀			
<i>a</i> 153 ♂ × 166 ♀	5	5	0	81	69	150	all	0
<i>b</i> 166 ♂ × 153 ♀	3	3	0	44	31	75	all	0
<i>c</i> 154 ♂ × 169 ♀	6	6	0	96	86	182	all	0
<i>d</i> 169 ♂ × 154 ♀	3	3	0	34	33	67	all	0
Total.....	17	17	—	255	219	474	all	0

TABLE VIII—S♂ × B♀ Parents. S × S and B × B Grandparents.  
S♀ × B♂ Parents. S × S and B × B Grandparents.

Broods Utilized and Color Character of Individuals Mated.	Number of Egg Masses Collected.	Number of S Broods.	Number of Mixed Broods.	Number of Individuals.		Total Number of Individuals.	B.	S.
				♂	♀			
<i>a</i> B 153 ♂ × S 134 ♀	10	10	0	182	144	326	0	326
<i>b</i> S 134 ♂ × B 153 ♀	2	2	0	38	32	70	0	70
<i>c</i> B 166 ♂ × S 157 ♀	2	0	2	46	34	80	13	67
<i>d</i> S 157 ♂ × B 166 ♀	5	3	2	117	76	193	16	177
<i>e</i> B 154 ♂ × S 119 ♀	2	0	2	50	38	88	20	68
<i>f</i> S 119 ♂ × B 154 ♀	8	6	2	149	116	265	10	255
<i>g</i> B 169 ♂ × S 112 ♀	6	5	1	108	91	199	8	191
<i>h</i> S 112 ♂ × B 169 ♀	6	5	0	88	79	167	0	167
Total.....	41	32	9	778	610	1388	67	1321

to whether the B character would reappear according to Mendelian expectations, or the S character again carry over.

*Experiment 5.* Inspection of Table I, *a*, columns 6 and 8, shows that some of the S × S matings produced pure broods, while some produced mixed broods. A number of matings were

TABLE IX—B × B. (From S × S, Same Parentage as in Table X.)

Broods Utilized (Note-book Numbers).	Number of Egg Masses Collected.	Number of Broods True to Parents	Number of Mixed Broods.	♂	♀	Total Number Individuals.	B.	S.
<i>a</i> 93♂ × 109♀	10	all	0	119	158	357	all	0
<i>b</i> 93♀ × 109♂	2	all	0	41	21	62	all	0
<i>c</i> 135♂ × 113♀	9	all	0	136	123	259	all	0
<i>d</i> 135♀ × 113♂	2	all	0	36	27	63	all	0
<i>e</i> 113♂ × 128♀	4	all	0	63	49	112	all	0
<i>f</i> 113♀ × 128♂	6	all	0	97	71	168	all	0
<i>g</i> 131♂ × 139♀	5	all	0	109	90	199	all	0
<i>h</i> 131♀ × 139♂	3	all	0	50	36	86	all	0
<i>i</i> 161♂ × 156♀	2	all	0	22	28	50	all	0
<i>j</i> 161♀ × 156♂	1	all	0	21	14	35	all	0
<i>k</i> 137♂ × 135♀	4	all	0	74	67	141	all	0
<i>l</i> 137♀ × 135♂	2	all	0	40	36	76	all	0
<i>m</i> 162♀ × 139♂	2	all	0	27	35	62	all	0
Total.....	52	all	0	915	655	1570	all	0

made between similars from mixed broods, columns 9 and 10, to obtain data for comparison with Tables II and III.

It will be remembered that Table II represents results of B × B that had bred true to B × B parents, and Table III represents results of S × S that had bred true to S × S parents.

Tables IX and X represent results of matings of B × B and S × S, respectively, between individuals from mixed broods, *i. e.*, from broods that had not bred entirely true to parentage.

We find upon inspection that, as in Tables II and III,  $B \times B$  produces offspring like parents, while  $S \times S$  under similar conditions produces in part pure broods, and in part mixed broods.

In the initial experiment, adults were isolated according to color type, as already stated, as soon as color type was established or in the morning succeeding the night during which adults had issued. Since mating does not take place for several days after the adults issue, I considered this a sufficient safeguard against

TABLE X— $S \times S$ . (From  $S \times S$ , Same Parentage as in Table IX.)

Broods Utilized (Note-book Numbers).	Number of Egg Masses Collected.	Number of Broods True to Parents.	Number of Mixed Broods.	♂	♀	Total Number Individ- uals.	Total Pure S.	Mixed Broods.	
								B.	S.
<i>a</i> 93♂ × 109♀	7	5	2	128	110	238	168	20	30
<i>b</i> 93♀ × 109♂	1	0	1	27	19	46	0	7	39
<i>c</i> 113♂ × 128♀	2	1	1	39	28	67	35	9	23
<i>d</i> 113♀ × 128♂	6	2	4	134	96	230	58	53	119
<i>e</i> 131♀ × 139♂	1	0	1	24	16	40	0	12	28
<i>f</i> 161♀ × 156♂	1	0	1	20	27	47	0	7	40
Total . . . . .	18	8	10	372	296	668	0	108	299

mating before isolation. It has been suggested to me that the possibility exists that some of the adults escaped notice until mating had taken place. If this were the case, it would account for the discrepancy in results between Table I, *b*, and Table IX.

While the data in Table X are recognizably insufficient, they point in the same direction as results drawn from previous tables of  $S \times S$  matings; that is, that  $S \times S$ , when presumably not far removed from  $B$  progenitors produces two kinds of broods—broods wholly like the parents and mixed broods. Table IX shows conclusively that  $B \times B$  produces offspring true to parents in the first generation from similar parents, leaving the discrepancy between this table and Table I to be accounted for as suggested.

A number of matings were made between similar individuals, the offspring of dissimilar parents. The broods chosen for these matings were taken from those represented in Table I, *c* and *d*.

TABLE XI—S×S.

Broods Utilized.	Color of Parents and Grandparents.	Number of Egg Masses.	Number of Broods Similar to Parents.	Number of Mixed Broods.				Total in True Broods.	Total in Mixed Broods.	
					♂	♀	Total.		S.	B.
<i>a</i> 24 ♂ × 56 ♀	$\left. \begin{array}{l} S \times S - P. \\ S \times B - G. P. \end{array} \right\}$	10	3	7	217	141	358	100	190	68
<i>b</i> 56 ♂ × 24 ♀										
<i>c</i> 60 ♂ × 107 ♀	$\left. \begin{array}{l} S \times S - P. \\ B \times S - G. P. \end{array} \right\}$	3	—	3	67	51	118	—	95	23
<i>d</i> 107 ♂ × 60 ♀										
<i>e</i> 84 ♂ × 108 ♀	$\left. \begin{array}{l} S \times S - P. \\ B \times S - G. P. \end{array} \right\}$	2	1	1	29	23	52	28	20	4
<i>f</i> 108 ♂ × 84 ♀										
Total.....		36	16	20	700	489	1189	422	612	155

In each case the dissimilar parents had produced mixed broods. The following diagram shows the method of mating for data of color inheritance of first generation from mixed parentage:

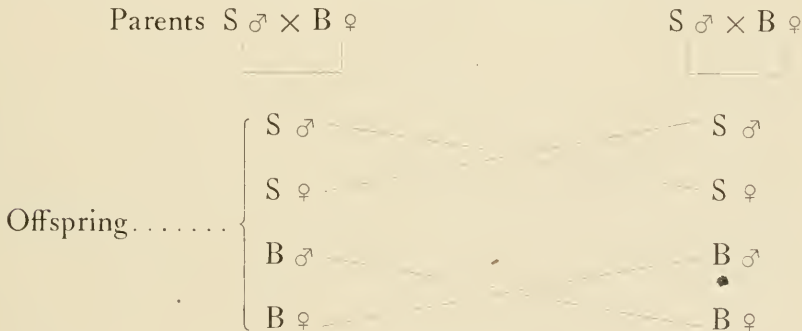

Table XI shows results of  $S \times S$  matings from both  $S \text{ ♂} \times B \text{ ♀}$  and  $B \text{ ♂} \times S \text{ ♀}$  parentage, while Table XII shows results of  $B \times B$  matings from the same parents.

The data in these tables add to the evidence of previous tables that B behaves like a Mendelian recessive, reproducing its kind, while S behaves like a Mendelian dominant, reproducing both its own kind, S, and the recessive, B.

TABLE XII— $B \times B$ .

Broods Utilized.	Color of Parents and Grandparents.	Number of Egg Masses.	Number of Broods Similar to Parents.	Number of Mixed Broods.	♂	♀	Total.	B.	S
<i>a</i> 24 ♂ × 56 ♀	{ B × B — P. S × B — G. P. }	3	3	0	56	42	98	all	0
<i>b</i> 56 ♂ × 24 ♀									
<i>c</i> 60 ♂ × 107 ♀	{ B × B — P. B × S — G. P. }	7	7	0	132	88	220	all	0
<i>e</i> 84 ♂ × 108 ♀	{ B × B — P. B × S — G. P. }	2	2	0	43	22	65	all	0
Total.....		19	19	0	361	233	594	all	0

At date of writing, the available material for the fifth generation matings is very much reduced, being confined to fifteen B broods pure bred for four generations and five S broods pure bred for the same length of time. These have shown no tendency to mate, and it is hoped that they will hibernate and form a nucleus for next year's work; failing this, the experiment will be continued with the first outdoor individuals to appear in the spring.

## SUMMARY.

1. No amount of crossing between the two characters in question accomplishes any disintegration or breaking up of either one. These are absolutely fixed with reference to each other in this species. (Tables I and VIII.)

2. In the offspring of a cross between the two characters, either both characters, or only one, the spotted, appears. (Tables I and VIII.) (Data on the latter point are insufficient.)

3. Cross-bred B's, namely, B's appearing in a cross between the two opposing characters, transmit B only to the offspring when similars are bred together. The B character is, therefore, stable, or self-perpetuating in the first generation. (Tables II, IV, VII, IX, XII.)

4. Cross-bred S's transmit both opposing characters to the offspring, the offspring likewise transmitting both characters, though bred from similar parents. (Tables III, VI, X.)

5. In the third generation from similar parents, S's appear to breed true. (Table V.)

While this summary shows no exact parallelism to Mendelian results, it is in accord with Mendelian principles in the following features:

1. Character S of  $S \times B$  parentage behaves like a dominant when mated with S. It appears always in greater numbers than character B (with the exception noted in Table I, *b*) and its broods fall into two categories, *i. e.*, pure broods (each individual being similar to the parents) and mixed broods (broods made up in major part of S, in minor part of B). Its behavior when mated with B must be further noted, I believe, before we can say assuredly that it is a "fully normal Mendelian dominant" in all respects.

2. Character B behaves like a Mendelian recessive in that from its first appearance (with the exception noted in Table I, *b*) it reproduces B only.

3. As to the "segregation" of characters in the germ cell, or "purity of the germ cell," it is evident that only one of the two opposing characters in question is called into activity in the somatic cells capable of expressing it, namely, the cells of the wing covers, and that as far as the experiments extend, individuals in each series appear at once, or eventually, to breed true.

In conclusion it appears from this single year's observations that dichromatism and variability are two distinct characteristics as represented in this species. The heredity of the dichromatism is such that if any barrier should interpose to intercrossing between the two types, each would eventually become permanently established. In this seems to lie its only evolutionary significance.

EXPLANATION OF PLATE.

- Fig. 1. *Lina lapponica*, immediately after casting pupal skin, showing absence of pigment in elytras.  
Fig. 2. *Lina lapponica*, 10 or 15 minutes after casting pupal skin, spotted areas outlined in elytras.  
Fig. 3. *Lina lapponica*, 15 or 20 minutes after casting pupal skin early drab stage of both S and B types.  
Fig. 4. *Lina lapponica*, about 45 minutes after casting pupal skin, S type (mature).  
Fig. 5. *Lina lapponica*, 20 or 25 minutes after casting pupal skin, later drab stage of B type.  
Fig. 6. *Lina lapponica*, about 45 minutes after casting pupal skin, B type (mature).





Mary Wellman del.



## EVOLUTION WITHOUT MUTATION.<sup>1</sup>

BY

C. B. DAVENPORT.

Professor de Vries having found in nature races that seem to have arisen suddenly, fully formed, and having repeatedly observed mutating individuals that breed true, declares, in his "Mutationstheorie," for the universality of mutation as the method of phylogenetic differentiation. He says (1901, p. 139): a gradual origin of elementary species is not yet known but very many cases are known in which species have suddenly made their appearance. "Nach der Mutationstheorie sind die Arten nicht durch allmähliche, während Jahrhunderte oder Jahrtausende fortgesetzte Selection entstanden sondern stufenweise, durch plötzliche, wenn auch ganz kleine Umwandlungen."

The mutation theory as a sufficient theory of evolution has many supporters. Bateson has long urged a theory of this sort as a result of his studies, particularly on the data collected in his "Materials for the Study of Variation," 1894. In his recent book "Evolution and Adaptation" Morgan adopts de Vries' views.

Now it seems to be a common characteristic of men of science when they have discovered a real and large truth to insist on its universality. But, particularly in biology, this tendency is fraught with danger on account of the complexity of the phenomena involved. I am quite convinced (and have, indeed, for more than a decade in my university lectures contended) that mutation or sporting plays an important part in evolution. I yield to no one in admiration for the work of the genial author of "Die Mutationstheorie," a work that has placed experimental evolution on a solid basis as a science and which has thus rendered a service to biology with which Darwin's only compares. Yet, I think, the acceptance of mutation as a method of evolution should not prevent us from conceding the force of any evidence that selection of

<sup>1</sup>Read before National Academy of Sciences, Chicago, November, 1903.

trivial or individual variations has had something to do with the origin of species.

For what are species? They are assemblages which differ in one or more of their characters to so pronounced a degree as to meet the more or less hazy ideals of the systematist. Now it is quite certain that such differences may arise in several ways. I propose to present certain evidence indicating that the differences between certain recognized species are of the order of accumulated individual variations and not of the order of mutations. Such evidence will then go to prove that evolution may, in some cases, take place without mutation.

Evidence as to the method of origin of species should be looked for in a group where closely related species are found to-day. Any interspace of distribution or time should be searched to see whether there are any graduated, transitional forms, or whether, on the contrary, a sudden change of character occurs. There are, in general, two kinds of series available for examination: one is the geographical, the other the palæontological series. At the present day two "species" are often found occupying two more or less distant regions of the continent. If we examine the intervening territory shall we find all gradations between the species or shall we find a sudden transition from one to the other? We should expect the sudden transition only if mutation is the sole method of origin of species; on the other hand, if fine intergradations appear these would speak for evolution by trivial variation. So, too, if a series of fossils connecting one species A with a second B are examined a sudden transition or a gradual one will be found as mutation has or has not acted in the case in question.

The facts of geographical variation are well illustrated in the broad territory of North America. Our eastern song sparrow, to cite a single example, was formerly thought to be replaced by a distinct species on the Pacific Coast in the vicinity of San Francisco, by a small light-colored desert species in Arizona and by a large dark species in Alaska. Later collections from intermediate localities revealed intermediate forms so that the different geographical forms are now regarded as varieties of one widespread species showing fine gradations in coloration and structure from place to place. In speaking of the results of the study of geographical variation of land birds in America, Newton ('93-'96, p. 343) says: "The great fact was established that, given a species

. . . which had a wide range on a continent, the variation exhibited by individuals from different localities is generally so considerable that it is hardly possible to predict its amount while almost every intermediate form may be found if the series of specimens be large enough."

To get additional data relating to geographical variation I have made quantitative studies of races of *Pecten* inhabiting different geographical regions. My first example will illustrate the fact of geographical variation where the extremes are not usually called species. *Pecten opercularis* occurs on the coast of Europe from the Lofoten Islands to the Canary Islands and throughout the Mediterranean Sea. I have studied (1903) specimens from three localities on the coast of Great Britain: at Eddystone Light, the Irish Sea, and the Firth of Forth, at north latitudes  $50^{\circ} 15'$ ,  $54^{\circ} 18'$  and  $56^{\circ} 05'$ , respectively. I find that the individuals from the ends of the series are the most unlike and that those from the intermediate latitudes are intermediate in most of their dimensions, as the following table shows:

	Eddystone.	Irish Sea.	Firth of Forth.
Maximum dorso-ventral diameter	70 mm.	77 mm.	80 mm.
Ratio ant.-post. to dorso-ventral diameter when latter = 67 mm..	1.067	1.061	1.039
Ratio hinge length to antero-posterior diameter .....	0.507	0.483	0.473
Half globosity at length of 53 mm.	0.151	0.151	0.132
Relative length of ears to hinge...	—	shortest	longest
Average number of rays.....	17.478	18.101	17.673
Standard deviation of rays.....	1.000 ± .020	1.074 ± .021	1.117 ± .019
Coefficient of variability.....	5.72	5.93	6.32

This series shows that there is a geographical variation and that the transition from one extreme to the other may be gradual.

The second example has to do with the *Pecten*s of the East coast of the United States. On the shores of Long Island is a species of scallop known as *Pecten irradians*. On our Gulf of Mexico coast occurs a second "species"—*P. gibbus*. For the

purposes of this paper these two form units may be considered distinct species although some persons, considering facts like those here presented, would regard the two as varieties, but this difference in view does not affect our argument. When shells from Long Island and the Gulf Coast at Tampa, Fla., are compared they are found to differ in color, the lower valve of the Gulf shells lacking the blue of the more northern shells and being white or white and red. They differ quantitatively as follows:

	Long Island.	Tampa.
Average number of rays, R. valve...	16.48 ± .08 to 17.35 ± .02	20.512 ± .030
Average globosity of shell when antero-posterior diameter = 57-62 mm.....	.283 ± .010	.314 ± .010
Average excess of antero-posterior diameter over dorso-ventral when latter = 58-60 mm.....	+6.1 mm.	+1.5 mm.

Taken together these three pairs of characters seem satisfactorily to differentiate the two species. But when we study shells from Cape Hatteras (Morehead, N. C.) we find here a form unit in many respects constituting a link connecting the two species. The color is quite intermediate. The number of rays is 17.3, which is intermediate between some Long Island localities and Tampa, but more like Long Island. The globosity of the shell is much like that of Tampa, being 0.319 for shells of a length of 59 mm. The range of globosity is such as largely to bridge the gap between the means of the Tampa and Long Island lots. The average excess of antero-posterior diameter is 2.5 mm. for 59 mm. shells; thus intermediate between the 1.5 mm. of Tampa and the 6 mm. of Long Island.

Finally, important evidence is afforded by a series of fossils from the Pliocene or late Miocene of the Nansemond River (James River system) at Jack's Bank near Suffolk, Va. These fossils are *Pectens*<sup>1</sup> closely related to *P. irradians* and known

<sup>1</sup>Now deposited at the University of Chicago.

as *Pecten eborus* of Conrad. I gathered shells from three layers, at 1 foot, 4 to 6 feet and 15 feet above tide water. As there were relatively few from the middle layer these shells are not considered here. These layers represent periods of time, the upper layer of molluscs having lived latest.

First, let us examine the number of rays in the right and left valves from the bottom and top layers and, for comparison, in recent shells (1900) from Morehead, N. C., in default of living *Pectens* from a nearer locality. Both averages (A) and indices of variability ( $\sigma$ ) are given, although the former alone are of special importance in this discussion. The number of shells measured in each case is given in the column headed *n*.

NUMBER OF RAYS.						
Right Valve.			Left Valve.			
<i>n</i>	A	$\sigma$	<i>n</i>	A	$\sigma$	
Lowest tier . . . . .	164	22.478 ± .059	1.118 ± .042	138	21.674 ± .070	1.223 ± .049
Upper tier . . . . .	163	21.693 ± .058	1.104 ± .041	134	21.119 ± .065	1.121 ± .046
Morehead . . . . .	449	17.307 ± .017	0.821 ± .021	558	17.228 ± .028	0.982 ± .020

GLOBOSITY OF VALVE—*i. e.*,  $\frac{\text{Transverse diameter}}{\text{Dorso-ventral diameter}}$  WHEN DORSO-VENTRAL DIAMETER IS 57-61 MM.

Right Valve.			Left Valve.			
<i>n</i>	A	$\sigma$	<i>n</i>	A	$\sigma$	
Lowest tier . . . . .	13	.1481 ± .0013	.0072 ± .0009	8	.1975 ± .0039	.0164 ± .0028
Upper tier . . . . .	17	.1579 ± .0017	.0107 ± .0012	8	.2063 ± .0019	.0078 ± .0017
Morehead . . . . .	75	.3303 ± .0012	.0158 ± .0008	129	.2800 ± .0010	.0161 ± .0007

RATIO OF ANTERO-POSTERIOR TO DORSO-VENTRAL DIAMETER WHEN LATTER IS 57-61 MM.

Right Valve.			Left Valve.			
<i>n</i>	A	$\sigma$	<i>n</i>	A	$\sigma$	
Lowest tier . . . . .	10	1.0960 ± .0049	.0232 ± .0035	7	1.0750 ± .0033	.0131 ± .0023
Upper tier . . . . .	25	1.0800 ± .0043	.0321 ± .0030	25	1.0560 ± .0038	.0283 ± .0027
Morehead . . . . .	52	1.0411 ± .0024	.0258 ± .0017	127	1.0459 ± .0015	.0261 ± .0011

The number of varieties (*n*) is fairly satisfactory for determining the number of rays because this quality is independent of the size (age) of the shell and consequently shells of all sizes were taken. The proportions of shell diameters, on the contrary, change greatly with age; moreover, it seemed desirable to take shells of the same size from all series whether the modal size was small or great. Consequently *n* is small in the ratio determinations and the probable errors correspondingly high. Despite the large size of the probable errors there is a significant difference in

the shells of the three epochs; the shells from the bluff being, however, more like each other than like those of Morehead.

The series show that the number of rays in both right and left valves has diminished since the Pliocene and that the reduction had made progress during the interval from the lowest deposits in Jack's Bank to the uppermost deposits. They show also that the change in question has been of the quantitative order rather than of the qualitative or mutational.

Again, the shells have been becoming more globose. For, the ratio of transverse diameter of either the right or the left valve to its dorso-ventral diameter has increased. Although the recent *P. irradians* is twice as globose as the fossil *P. eboreus* the later fossil deposits show a change from the earlier in the same direction and make it probable that a quantitative change that was in progress in geological times has continued to the present time.

Finally, both valves have been getting more nearly circular—the antero-posterior diameter becoming more nearly equal to the dorso-ventral one. Here, again, there is a quantitative change in a character; not the introduction of a new one.

Apart from a certain bleached appearance of the shell and its less weight (both due, in part at least, to postmortem changes) the fossil shells differ from the recent ones, so far as I can see, in no other respects than the three enumerated above. It seems justifiable, therefore, to conclude that the evolution from the one species to the other has been without mutation and solely by graduated variation.

#### SUMMARY.

The process of evolution has taken place by various methods and not always in the same way. It is no more justifiable to maintain that all evolution is by mutation than that evolution has always proceeded by slow stages. The best evidence for slow evolution is found in wide-ranging species which while differing greatly at the limits of their range exhibit all gradations in intermediate localities (*Melospiza*, *Pecten*); also in fossil series (*Pecten eboreus* and *P. irradians*) where the change from one horizon to the next is of the quantitative order. Thus evolution may take place without mutation.



LITERATURE CITED.

- BATESON, W., '94.—Materials for the Study of Variation. London: Macmillan, 598 pp.
- DAVENPORT, C. B., '03.—Quantitative Studies in the Evolution of Pecten. III. Comparison of Pecten Opercularis from Three Localities of the British Isles. Proc. Amer. Acad. Arts and Sciences, xxxix, 123-159. Nov.
- DE VRIES, H., '01.—Die Mutationstheorie. Versuche und Beobachtungen über die Entstehung von Arten im Pflanzenreich. Leipzig: Veit & Co. 1901. 648 pp., 8 Taf.
- NEWTON, A., '93-'96.—A Dictionary of Birds. London: A. & C. Black. 1088 pp.



# MOSAIC DEVELOPMENT IN ASCIDIAN EGGS.

BY

EDWIN G. CONKLIN.

WITH 82 FIGURES.

I. Normal Development .....	146
II. Objects and Methods of Experiment .....	151
III. Results of Experiments .....	155
1. Right or Left Half Embryos .....	157
a. Cleavage .....	157
b. Gastrulation .....	163
c. Formation of Larva .....	168
(1) Neural Plate and Sense Organs .....	168
(2) Notochord .....	169
(3) Muscles and Mesenchyme .....	169
2. Three-Quarter Embryos .....	170
3. Anterior Half Embryos .....	175
4. Posterior Half Embryos .....	179
5. Quarter Embryos .....	183
6. Eighth or Sixteenth Embryos .....	189
7. Anterior and Posterior Half Gastrulae .....	193
IV. Other Experimental Work on the Ascidian Egg .....	197
1. Cleavage .....	198
2. Gastrula .....	199
3. Larva .....	200
a. Neural Plate and Sense Organs .....	203
b. Notochord .....	204
c. Muscles and Mesenchyme .....	205
V. Regulation in Ascidian Egg and Embryo .....	206
VI. General Conclusions .....	209
1. Organ-Forming Substances .....	209
2. Localization of Oöplasmic Substances .....	210
3. Cleavage and Localization .....	213
4. Determinate and Indeterminate Cleavage and Development .....	214
Summary .....	216
Literature Cited .....	221

In almost every instance in which fragments of eggs or isolated blastomeres have been found to be capable of giving rise to entire larvæ the substance of the unsegmented egg is apparently undifferentiated and the cleavage cells are so nearly equal and homogeneous that it has not been possible to trace the lineage of individ-

ual blastomeres throughout the development. The most notable exception to this rule is found in the case of ascidians. That the cleavage of the egg in these animals is constant in form and differential in character and that specific blastomeres are destined in the course of normal development to give rise to specific parts of the larva has been demonstrated by Van Beneden and Julin, Chabry, Castle, and many others. Chabry ('87) also showed, in one of the earliest experimental investigations dealing with the potency of cleavage cells, that individual blastomeres of *Ascidia aspersa* always develop into those parts of the larva which they would produce under normal conditions. On the other hand, Driesch ('95) discovered, some eight years later, that in *Phallusia mammilata* individual blastomeres up to the 4-cell stage at least are capable of giving rise to entire larvæ and this conclusion was afterward confirmed by Crampton ('97) in the case of *Molgula manhattensis*. Since the results of Chabry were thus flatly contradicted by these later investigators and as they have been defended by no one who has actually experimented on these eggs<sup>1</sup> these results have been generally discredited and the ascidians are now commonly regarded as belonging to that group of animals in which the early cleavage cells are equipotential. The ascidians, therefore, should afford an excellent opportunity of determining the exact method by which an egg fragment or isolated blastomere gives rise to an entire larva, since in this case it is possible to follow the lineage of individual cells until they enter into larval organs; furthermore, they should afford means of testing the justice of the distinction which has been proposed (Conklin, '97) between determinate and indeterminate types of cleavage, and finally they should throw light upon the significance of the high degree of differentiation which is known to exist in the early development of these animals.

#### I. NORMAL DEVELOPMENT.

I have recently ('05<sup>1</sup>) shown that these differentiations of the ascidian egg are much greater than has heretofore been supposed; in the unsegmented egg of *Cynthia (Styela) partita* at least five distinct kinds of oöplasm can be recognized. These are, (1) the

<sup>1</sup>Several persons, viz: O. Hertwig ('92), Roux ('92), Weismann ('92), Barfurth ('93) have discussed Chabry's work from a critical point of view.

deep yellow protoplasm which later enters into the muscle cells of the tail of the larva; (2) the light yellow material which becomes mesenchyme; (3) the light gray material which forms the chorda and neural plate; (4) the slate gray substance which becomes endoderm, and (5) the clear transparent protoplasm which gives rise to the general ectoderm. All of these substances are recognizable in the egg before the first cleavage and immediately after that cleavage they all occupy their definitive positions in the egg, the yellow protoplasm forming a yellow crescent around the posterior side of the egg just dorsal to the equator, the light gray substance forming a gray crescent around the anterior border of the egg, the slate gray substance lying at the middle of the dorsal hemisphere and between the two crescents, while the transparent protoplasm is chiefly localized in the ventral hemisphere of the egg. In these positions and from these substances the organs and germinal layers specified arise.

At the first cleavage of the egg all of these substances and areas are equally divided, since this cleavage lies in the plane of bilateral symmetry of the egg and future embryo. The second cleavage plane is perpendicular to the first and separates the gray crescent in front from the yellow crescent behind; the cells of the anterior quadrants are therefore very unlike the posterior ones and the two can always be distinguished at a glance. (Fig. 1.) The third cleavage is equatorial and separates four clear ventral cells from four dorsal ones which contain the yellow and gray crescents and the deep gray material. (Fig. 2.) The ectoplasm is now completely segregated in the four ventral cells but the other oöplasmic substances are not as yet located in separate cells, though from the time of the first cleavage onward their locations and boundaries are perfectly sharp and distinct.

At the fourth cleavage each of the eight cells divides, thus giving rise to sixteen cells (Fig. 3) and at the fifth cleavage these are increased to thirty-two. During the fifth cleavage the substance of the gray crescent is segregated into four cells ( $A^{0.2}$ ,  $A^{0.4}$ , Fig. 4)<sup>1</sup> at the anterior border of the egg, while the yellow crescent comes

<sup>1</sup>The system of cell nomenclature employed in this paper is similar to that used by Castle ('96) and is fully explained in my work on the cell-lineage ('05<sup>1</sup>); in brief *A* and *a* designate cells of the anterior half of the egg, *B* and *b* those of the posterior half, the capitals being used for cells of the vegetal (dorsal) hemisphere, the lower case for those of the animal (ventral) hemisphere. Corresponding cells of the right and left sides receive the same designation, except that those of the right side are underscored.

NORMAL DEVELOPMENT OF *CYNTHIA PARTITA*, 4-CELL TO 64-CELL STAGES;  $\times$  333.

The yellow crescent which surrounds the posterior half of the egg dorsal to the equator is stippled. The gray crescent around the anterior border of the egg is left unshaded. The boundary between the clear protoplasm and the yolk is indicated by a crenated line. The polar bodies (shaded by vertical lines) lie at the animal or ectodermal pole.

Fig. 1. Four-cell stage from the animal pole, the yellow crescent showing through the egg.

Fig. 2. Telophase of the third cleavage (8-cell stage), from the left side.

Fig. 3. Twenty-cell stage from the animal (ventral) pole.

Fig. 4. Twenty cells, transitional to the 24-cell stage, from the vegetal (dorsal) pole. The gray crescent is now segregated in the two pairs of cells  $A^{6.2}$ ,  $A^{6.4}$ ; the yellow crescent will be localized in separate cells at the close of the division which has already begun in the cells  $B^{5.1}$ .

Figs. 5 and 6. Ventral and dorsal views of the same egg in the 64-cell stage. The yellow and the gray crescents each consist of a double arc of cells; the anterior arc of the gray crescent ( $A^{7.4}$ ,  $A^{7.5}$ ) is composed of neural plate cells, the posterior arc ( $A^{7.3}$ ,  $A^{7.7}$ ), of chorda cells; only two pairs of cells in the yellow crescent ( $B^{7.4}$ ,  $B^{7.8}$ ) are muscle cells, the others are mesenchyme. The pair of cells  $A^{7.6}$  also gives rise to mesenchyme. All the other cells of the dorsal hemisphere (Fig. 6) are endodermal. All the cells shown in Fig 5, except those of the yellow and gray crescents, are ectodermal.

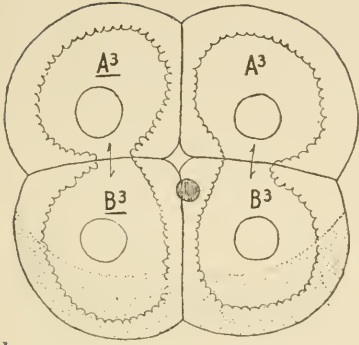

1

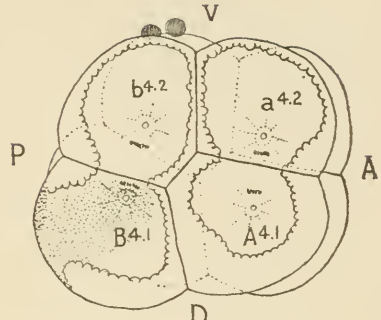

2

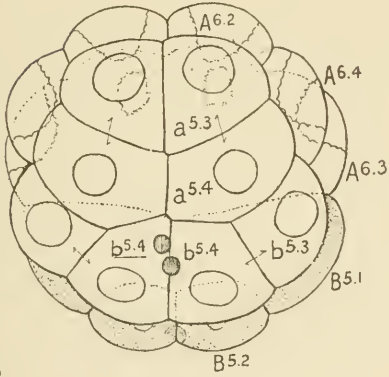

3

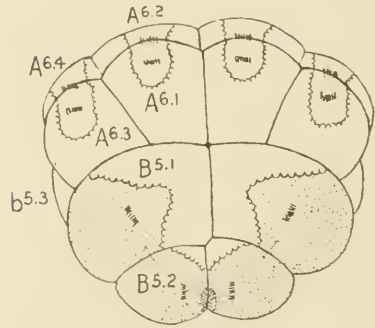

4

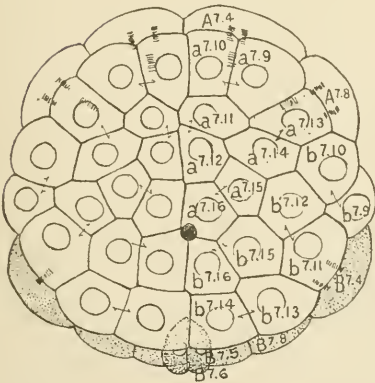

5

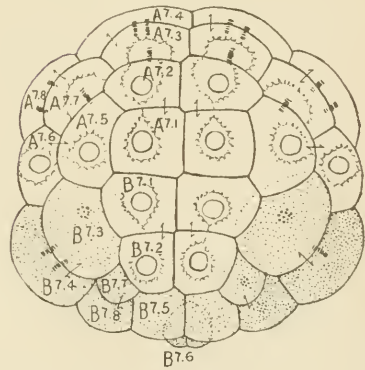

6

to occupy six cells ( $B^{6.3}$ ,  $B^{6.4}$ ,  $B^{6.2}$ ) around the posterior border (the spindles which lead to the formation of these six cells are indicated in Fig. 4). These thirty-two cells are increased to sixty-four at the next cleavage (Figs. 5 and 6); during this cleavage four chorda cells ( $A^{7.3}$ ,  $A^{7.7}$ ) are separated from the four neural plate cells ( $A^{7.4}$ ,  $A^{7.8}$ , Fig. 6), while the six cells of the yellow crescent have given rise to twelve, four of which are muscle cells ( $B^{7.4}$ ,  $B^{7.8}$ ) and eight mesenchyme ( $B^{7.3}$ ,  $B^{7.7}$ ,  $B^{7.5}$ ,  $B^{7.6}$ ). At the same time an additional pair of mesenchyme cells ( $A^{7.6}$ ) is separated from a pair of endoderm cells in the anterior quadrants. This is the only mesenchyme cell derived from the anterior quadrants.

At this stage all the substances of the germ layers and of the principal organs of the larva are gathered into separate cells, but although this segregation into separate cells comes relatively late in the cleavage these substances have been definitely localized in certain regions of the egg from the time of the first cleavage. Subsequent cleavages lead to changes in the shape of the embryo but produce no changes in this localization.

In the gastrulation the endoderm cells are depressed and are overgrown in front by the chorda cells and these in turn are covered by the neural plate cells; similarly the mesenchyme cells overgrow the endoderm at the posterior border of the blastopore, while the mesenchyme cells are overgrown by the muscle cells, and finally the latter by the ectoderm. (Figs. 7-10.) In the closure of the blastopore the anterior (dorsal) lip grows posteriorly until it covers most of the dorsal face, while the muscle cells form the lateral boundaries of the blastopore. (Figs. 9, 10.) In this overgrowth of the dorsal lip the chorda cells which originally lay at the anterior border of the egg are carried back into the posterior half of the embryo, where by interdigitation they form the chorda. The neural plate cells are also carried back with the chorda nearly to the posterior end of the embryo. The ventral (posterior) lip of the blastopore then grows forward over the remnant of the blastopore and the neural plate is rolled up into a tube which closes from behind forward. The muscle cells become arranged in three rows on each side of the chorda; in front of the muscle cells is a mass of small mesenchyme cells, while a double row of endoderm cells ventral to the chorda constitutes the cord of ventral or caudal endoderm. (Figs. 11 and 12.) Finally the tail of the larva elongates greatly and becomes coiled around the body of the



larva within the egg membranes, and about twelve hours after the fertilization of the egg the larva may hatch and become free swimming. However, in a considerable proportion of cases the larva never hatches but undergoes its metamorphosis within the egg membranes.

## II. OBJECTS AND METHODS OF EXPERIMENT.

This brief review of the normal development<sup>1</sup> shows that there is a remarkable degree of differentiation and localization of the substances of the egg and embryo and it seems to render necessary some further explanation of the results of the experiments of Driesch and Crampton; certain it is that the egg is highly differentiated and if portions of this differentiated oöplasm may give rise to portions of the larva which they would never produce under normal conditions it is important to know the steps by which this is accomplished.

With this object in view I spent the summer of 1904 at the Marine Biological Laboratory at Woods Hole, Mass., experimenting on the eggs of *Cynthia* (*Styela*) *partita* and of *Molgula* *manhattensis*; I was unable to obtain *Ciona intestinalis*, the normal development of which I had studied during the previous summer, and my experimental work is therefore limited to the two species first named. Most of my work was done on the egg of *Cynthia*, which is a better object for experimental work than that of *Molgula*, owing to its greater size and the more brilliant coloring of its different oöplasmic substances. Enough work was done on *Molgula*, however, to show that the development of isolated blastomeres is the same in this genus as in *Cynthia*.

All the experiments performed had for their purpose the testing of the potencies of the various substances and blastomeres of the egg. Injuries to the unsegmented egg of whatever nature, whether produced by sticking, cutting or shaking the eggs, invariably inhibited all further development. I have therefore been unable to test the developmental potencies of the different kinds of oöplasm of the unsegmented egg. But inasmuch as these substances are the same in appearance and localization before and

---

<sup>1</sup>For a more detailed account of the normal development of these ascidians the reader is referred to my previous papers on the "Organization and Cell-Lineage of the Ascidian Egg" ('05<sup>1</sup>), and on "Organ-Forming Substances in the Eggs of Ascidians" ('05<sup>2</sup>).

NORMAL DEVELOPMENT OF *CYNTHIA PARTITA*, GASTRULA TO TADPOLE;  $\times 333$ .

The neural plate or tube is finely stippled, the chorda coarsely stippled; muscle cells are shaded by vertical lines, mesenchyme by transverse lines.

Figs. 7 and 8. Ventral and dorsal views of a gastrula (180-cell stage), showing T-shaped blastopore, neural and chorda plates, mesenchyme and muscle cells. Most of the cleavage cells are in the ninth generation.

Figs. 9 and 10. Two views of the same gastrula from the dorsal pole; Fig. 9, showing the superficial cells, Fig. 10, those at a deeper level. The overgrowth of the dorsal lip of the blastopore and the approximation of the muscle cells of each side toward the median plane have reduced the blastopore to a longitudinal groove in the posterior half of the embryo. The ectoderm cells are in the tenth generation and there are in the entire embryo about 360 cells.

Fig. 11. Dorsal view of an embryo in which the neural plate (n. p.) is closing to form the neural tube (n. t.) Beneath the nerve tube is the notochord and on each side of the latter is shown a row of muscle cells (ms.) At the posterior end of the muscle rows is the caudal mesenchyme, at their anterior end the trunk mesenchyme (m'ch.)

Fig. 12. Young tadpole viewed from the left side, showing three rows of large muscle cells (ms.) along the side of the notochord (ch.); dorsal to the latter is the nerve tube (n. t.); anterior to the muscle rows is the trunk mesenchyme (m'ch.); ventral to them is the ventral or caudal endoderm (v. end.)

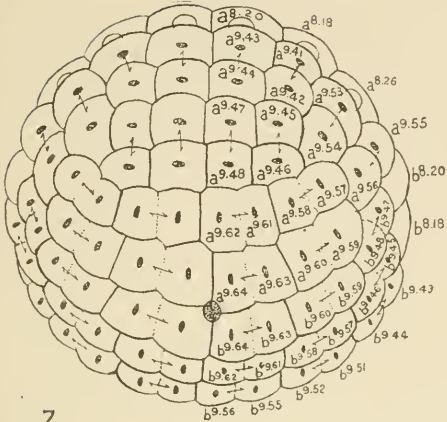

7

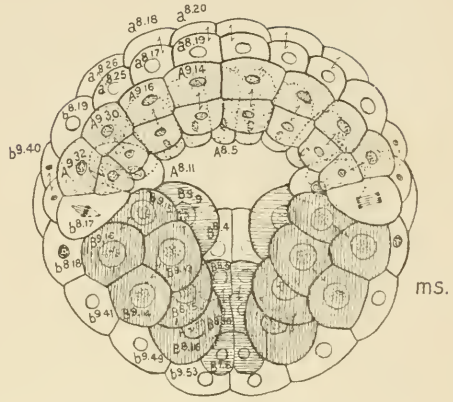

8

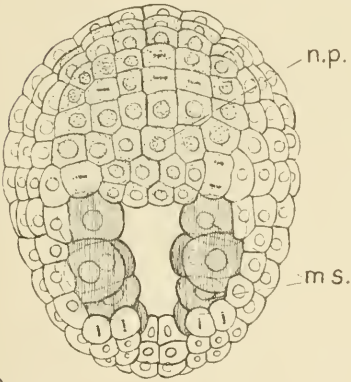

9

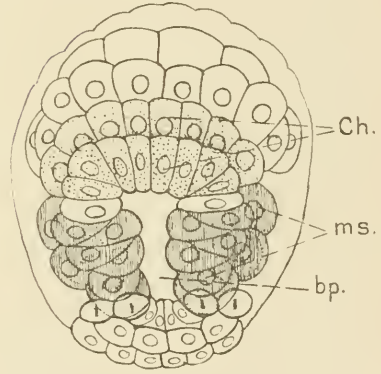

10

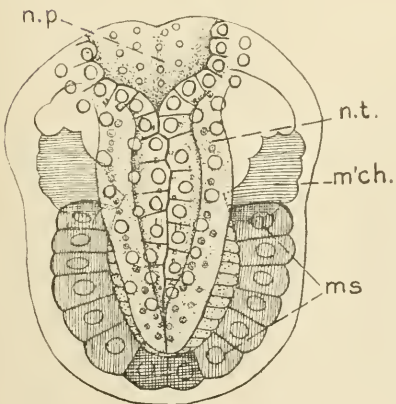

11

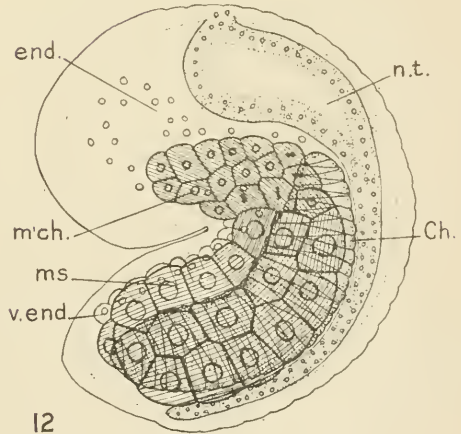

12

after cleavage begins it can scarcely be doubted that their potencies are also the same. Hundreds of experiments involving many thousands of eggs were made upon the various cleavage stages. The methods of experimenting which I employed were essentially like those used by Driesch and Crampton, viz: the eggs in the 2-cell, 4-cell, 8-cell or later stages were strongly spurted with a pipette, or were shaken in a vial, and thereby some of the blastomeres were frequently injured while others were uninjured and continued to develop. The injured blastomeres were rarely killed, as was shown by the fact that they remained transparent and entire for a day or more, whereas dead cells soon become opaque and disintegrate. These injured cells never again divide and sections show that their nuclei are frequently broken and their chromosomes scattered. Cells are more likely to be injured during nuclear division than during rest. The fact that these injured cells never again divide though they remain whole within the chorion and preserve their characteristic color and structure makes it possible to determine at all stages just what cell or cells have been injured. Whether or not the presence of these injured cells within the chorion may influence the development of the uninjured cells will be considered later. Attempts to completely separate individual blastomeres by the use of Herbst's calcium-free sea water were not successful, probably owing to the presence of the chorion and to the close union between the blastomeres.

In addition to this method of experimentation which yielded hundreds and thousands of eggs in which one or more of the blastomeres had been injured I also cut eggs and embryos in two with knives made from small needles. In no single instance was I able to get fragments of unsegmented eggs to develop; in the gastrula stages I was more successful, being able to cut gastrulæ in two in the manner described by Driesch ('03) and observe the subsequent development.

I have not attempted to repeat the various ingenious methods of injuring blastomeres which were devised and employed by Chabry, since they are necessarily slow and difficult of application and yield but a small number of injured eggs, whereas by simply spurting or shaking the eggs one may injure blastomeres in an enormous number of eggs which can then be sorted out and classified according to the character of the injury; furthermore the ease and certainty with which the identity of injured blastomeres of

Cynthia may always be determined renders unnecessary such experiments as Chabry's on the individual cleavage cells.

If one desires to trace with accuracy the lineage of individual blastomeres, whether in normal or experimentally altered development, it is essential that a large quantity of material should be available. In even the most favorable material the lineage of the later stages can be successfully studied only by the aid of fixed and stained material and without a large number of eggs it is difficult if not impossible to secure all the stages of development. Furthermore it is desirable that a considerable number of eggs of every stage be available for study, since the liability to error decreases with the number of cases studied. Accordingly, in addition to the study of living eggs during successive stages after their injury, many eggs were also fixed at brief intervals and were afterward stained and mounted entire or sectioned. For this purpose I have found Kleinenberg's picro-sulphuric acid followed by my picro-hæmatoxylin to give the best results. Entire eggs so prepared show cell outlines, nuclei and karyokinetic figures much more plainly than in the living condition; on the other hand the yellow crescent is less distinct since the yellow pigment is extracted by alcohol; nevertheless this crescent may always be recognized by its peculiar staining qualities and it therefore affords a never failing aid in orientation.

### III. RESULTS OF EXPERIMENTS.

In undertaking this work it seemed to me scarcely possible that all of these strikingly different kinds of oöplasm, each with its own peculiar developmental history and destiny, were nevertheless morphogenetically alike, as might be concluded from the results of Driesch and Crampton. On the other hand a possible escape from this conclusion was suggested by the fact that although the cleavage cells are strikingly different from one another, the isolation of the oöplasmic substances in them is not quite complete; almost all of the yellow protoplasm is contained in the yellow crescent; but a small amount of it is found around the nuclei of all the cells; most of the gray substance is contained within the dorsal hemisphere, but a small amount of it occurs in the ventral cells also; most of the clear protoplasm is found in the ventral hemisphere but a small quantity is also found in the dorsal cells.

It therefore seemed possible that the production of a complete larva from any one or two of the first four cells might be due to the replacing of a missing substance by the greater development of the trace of that substance contained in the cells in question. Thus the anterior quadrants which lack the yellow crescent might, perhaps, regenerate it from the small amount of yellow perinuclear protoplasm which they contain, and correspondingly the posterior quadrants might regenerate the lacking gray crescent from the small amount of gray substance which they contain. In the light of the work of Driesch and Crampton either there must be such regeneration, or the substances which appear so different must after all be each and all totipotent.

However the solution of this problem has turned out to be much simpler than I had supposed possible, viz: *isolated blastomeres do not give rise to entire larvæ, as claimed by Driesch and Crampton, but on the contrary each blastomere produces only those parts of a larva which would arise from it under normal conditions. The development is, in short, a "mosaic work."* Since the first cleavage is bilaterally symmetrical each of the first two blastomeres contains one-half of each and all of the substances of the egg and correspondingly the half larva which develops from one of these blastomeres contains portions of every larval organ. Owing to the fact that the cells which arise from an isolated blastomere close over the injured surface these partial embryos are rounded in form and many of the one-half larvæ resemble superficially whole larvæ of half size, but in no case are they complete. When the anterior or posterior quadrants of the 4-cell stage are killed nothing even remotely resembling a normal larva is ever produced. My results are therefore directly opposed to those of Driesch and they agree in all essential respects with those of Chabry.

The partial embryos and larvæ obtained in these experiments may be classified as right or left, anterior or posterior, dorsal or ventral, or composite forms. Furthermore they may be known as half, quarter, eighth, sixteenth, etc., embryos, according as they are produced from blastomeres of the 2, 4, 8, 16, etc., cell stages; however, the character of the embryo depends entirely upon the region from which the isolated blastomeres come and not upon the number of such blastomeres.

1. *Right or Left Half Embryos (Figs. 13-33, 36-46).*

## a. Cleavage.

When the right or left half of an egg is injured in the 2, 4 or 8-cell stage, the other half continues to segment in a normal manner, provided it was not also injured. I have traced the cell-lineage of these right or left half embryos up to the eighth generation of cleavage cells (the 112-cell stage of normal eggs), while I have determined the lineage of many individual cells as late as the ninth or tenth generation (218-360 cell-stage). The cell-lineage of these half embryos is essentially like the right or left half of a normal egg, except that the direction of division and consequently the position and size of some of the blastomeres may be slightly altered.

This alteration in the direction of cleavage is most evident in cases where the egg was injured in the 2-cell stage, and it is probably due to the fact that the uninjured blastomere in such cases becomes nearly spherical in shape, and does not remain hemispherical as in the normal egg. Owing to this fact the median pole of certain cleavage spindles, *i. e.*, the one next to the original median plane, is shifted toward the middle of that plane. The resulting mass of cells is, therefore, more nearly spherical than in the half of a normal embryo. (Figs. 13-20.) If the injury occurs in the 4-cell stage or later, the change in the direction of the early cleavages is not so evident as when it takes place in the 2-cell stage. In case one of the blastomeres was injured at the close of the first cleavage, the direction of the karyokinetic spindles of the second and third cleavages are entirely normal, since in both these cases they lie parallel with the first cleavage plane, Fig. 13; but in the fourth cleavage in which one pole of the spindles lies nearer that plane than the other, the median pole is shifted toward the middle of that plane and consequently the cells formed along the median plane come into closer contact with one another and the cell aggregate is more nearly spherical than in the right or left half of a normal 16-cell stage. (Figs. 14, 15, 21, 22.) These results entirely agree with those of Chabry and Crampton.

The fifth cleavage of the right or left half embryo is also like the normal except in the direction of a few of the divisions; *e. g.*, Fig. 16 is nearly normal but in Fig. 17 the division of the cell

## DEVELOPMENT OF RIGHT BLASTOMERE OF 2-CELL STAGE.

Figs. 13-20. Successive stages in the development of the same right half embryo, the left blastomere having been injured in the 2-cell stage; drawn at intervals of about five minutes. Here and elsewhere the yellow protoplasm is indicated by coarse stipples.

Fig. 13. Right half of 8-cell stage, posterior view. A small amount of yellow protoplasm surrounds the nucleus of the ectoderm cell  $b^{4,2}$ . The position of the cells shows that the ventral ends of the third cleavage spindles diverged from the first cleavage plane in the posterior quadrant and converged toward that plane in the anterior quadrant, just as in the normal egg. (See Conklin, '05<sup>1</sup>.)

Fig. 14. Right half of 16-cell stage, anterior view. The yellow crescent is seen through the cell  $B^{5,1}$ . In the normal egg of this stage the cells  $A^{5,1}$  and  $a^{5,3}$  lie more nearly in front of the cells  $A^{5,2}$  and  $a^{5,4}$ .

Fig. 15. Same stage as preceding posterior view. In normal eggs the cells  $B^{5,2}$  and  $b^{5,4}$  lie nearly behind the cells  $B^{5,1}$  and  $b^{5,3}$  and not on their median side.

Fig. 16. Right half of 30-cell stage, dorsal view.  $A^{6,2}$  and  $A^{6,4}$  are cells of the gray crescent;  $B^{6,2}$  and  $B^{6,3}$ , cells of the yellow crescent.

Fig. 17. Right half of 34-cell stage, posterior view. In normal eggs the cell  $B^{6,4}$  lies on the lateral border of  $B^{6,3}$ .

Fig. 18. Same stage as preceding, dorsal view. The cell  $B^{6,1}$  normally lies between  $B^{6,3}$  and  $A^{6,1}$ .



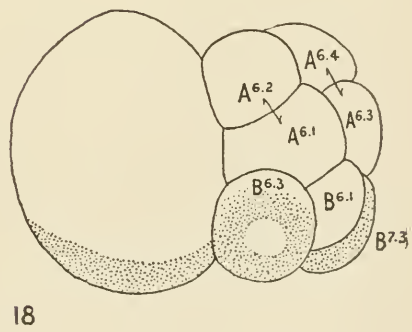
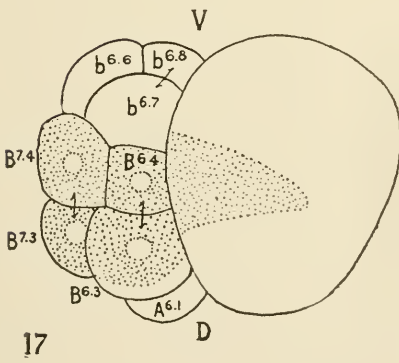
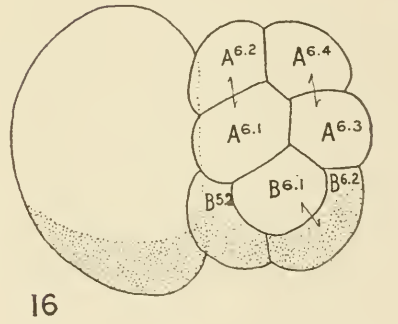
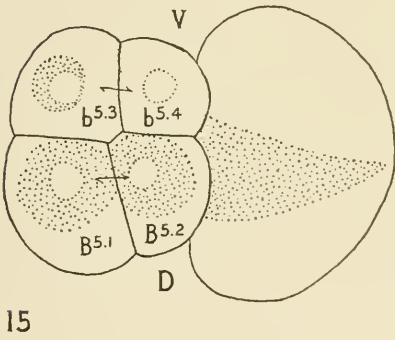
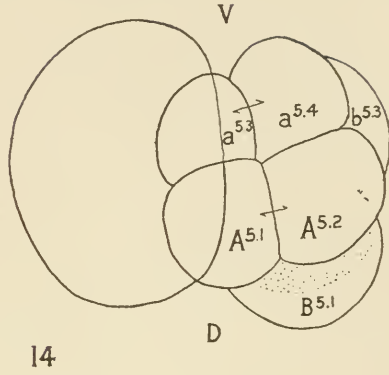
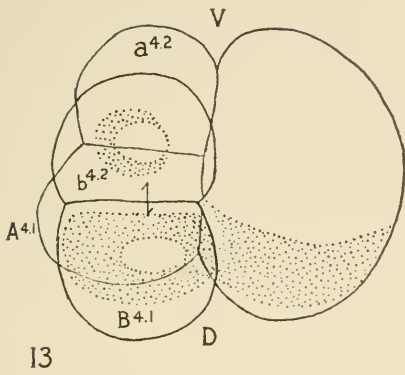

DEVELOPMENT OF RIGHT BLASTOMERE OF THE 2-CELL STAGE; ALSO OF RIGHT AND LEFT BLASTOMERES  
OF THE 4-CELL STAGE.

Figs. 19, 20. Same embryo as that shown in Figs. 13-18. Fig. 19. Right half of 46-cell stage, posterior view; the yellow crescent cells are not quite normal in position. Fig. 20. Right half of 48-cell stage, dorsal view. The caudal endoderm cells ( $B^{7.1}$  and  $B^{7.2}$ ) have been shoved away from the median plane by the cell  $B^{7.5}$ .

Figs. 21, 22. Fixed and stained preparations of half embryos in the 16-cell stage. Fig. 21. Right half embryo, posterior view. Fig. 22. Left half embryo, ventral-posterior view.

Figs. 23, 24. Successive stages of one and the same half embryo, the left half having been injured in the 4-cell stage, dorsal view. Fig. 23. Right half of 16-cell stage. Fig. 24. Right half of 32-cell stage. The cleavage is like the right half of a normal egg in every respect.

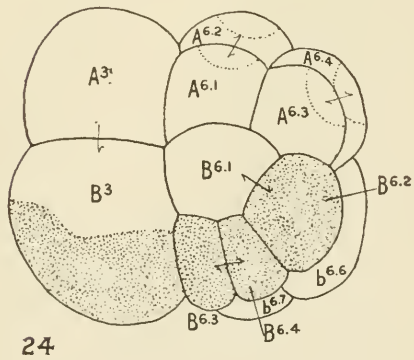
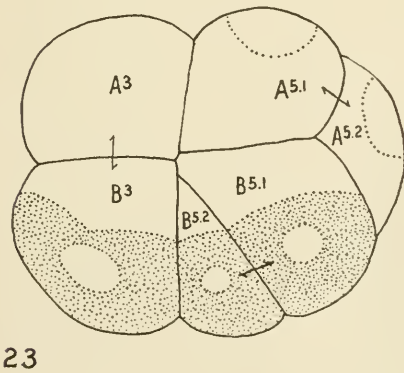
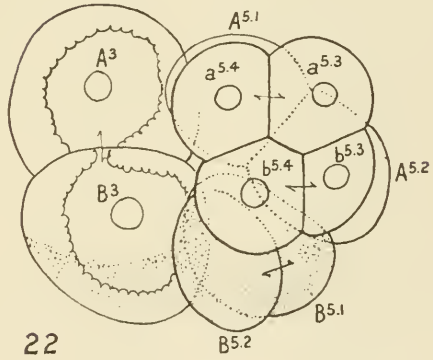
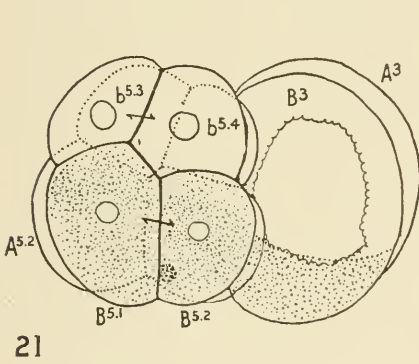
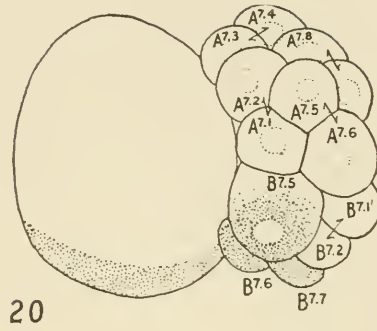
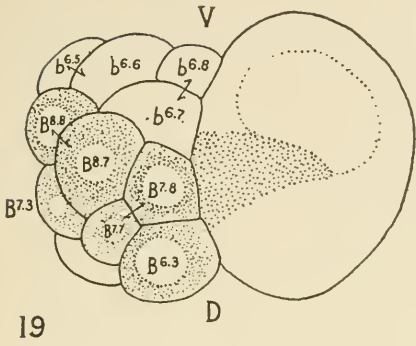

$B^{5.2}$  into  $B^{6.3}$  and  $B^{6.4}$  is almost at right angles to its normal direction. In other cases, as is shown in Fig. 24, this cleavage is normal in direction, and I am, therefore, of the opinion that the condition shown in Fig. 17 and the later stage of this same egg shown in Fig. 19 may be due to some slight injury to the developing half of this egg. In Fig. 18, which is a dorsal view of the same egg in the same stage as Fig. 17, the cells  $A^{6.2}$  and  $A^{6.4}$  have moved in toward the median plane as compared with Fig. 16, though in this respect, also, the corresponding stage shown in Fig. 24 is quite normal. This shifting of the anterior dorsal cells toward the median plane is shown again at the next cleavage (the sixth), of this egg. (Fig. 20.)

The seventh cleavage, which is shown in Figs. 25 and 26, is also normal except for the direction of a few of the divisions. The cells which constitute the yellow and gray crescents are in all respects like the right half of a normal egg. However the position of the cells  $A^{7.1}$  and  $A^{7.2}$ , Fig. 25, and the direction of division in several of the ectoderm cells shown in Fig. 26 are not quite normal.

In conclusion therefore it may be said that the cleavage of one of the blastomeres of the 2-cell stage or of the right or left blastomeres of the 4-cell stage, is like that of the corresponding half of a normal egg, except in minor details. Even these minor differences are not always present and when they are they do not alter the localization of the oöplasmic substances. In every case the distribution of the yellow, the gray and the clear substances to the different blastomeres is the same as in the right or left half of a normal egg; the cells of the yellow crescent, for example, form only the right or left half of a normal crescent, and the same is true of the gray crescent and of the other substances of the egg. Even the small amount of yellow protoplasm which is found around the nuclei of the posterior ectoderm cells  $b^{4.2}$ , Fig. 13, is perfectly normal in its occurrence and subsequent distribution.

I have elsewhere ('05<sup>1</sup>) shown that the localization of different oöplasmic substances in the ascidian egg precedes cleavage and that cleavage and localization are here relatively independent of each other; these experiments show that in both cleavage and localization the development of the right or left half of an ascidian egg is a "mosaic work," for the slight amount of regulation, which is manifested in the changes in the direction of certain cleavages, and the consequent closing of the embryo in no way alters the

histological character of the cleavage cells nor their developmental tendencies.

*b. Gastrulation.*

In the development of the right or left half of an egg the process of gastrulation sometimes occurs in an unusual manner. The most frequent modification of the normal process is that shown in Figs. 27, 29, 30, where the endoderm cells are not infolded but come to protrude above the level of the other cells, thus forming exogastrulæ. In later stages these endoderm cells must become infolded for it is a rare thing to see exogastrulæ or any indication of an original evagination of endoderm cells in any of the cultures of older embryos. By what process these exogastrulæ right themselves I have not been able to observe, but I think it probable that this like normal gastrulation is accomplished by overgrowth of the ectoderm cells and change of shape of the endoderm cells.

Sometimes when the endoderm cells are evaginated other portions of the blastula wall invaginate. In this way false gastrulæ may arise in which the infolded cells are not endodermal but ectodermal, as is clearly shown by their histological structure. (Fig. 63.)

While some embryos in the gastrula stage show such abnormalities as those which have just been described in other cases the gastrula is strictly a half one, as is shown in Fig. 31, and it seems to me probable that exogastrulæ or false gastrulæ only arise when the surviving half of the egg has been slightly injured. These half gastrulæ contain just one-half of all the cells of the normal gastrula and the position of the various cells and organ bases is essentially like that which occurs in the right or left half of a normal gastrula; the cells of the yellow crescent lie along one side only of the blastopore groove; the neural plate and chorda cells each form half of the arc which is normally present in the anterior lip of the blastopore, while the closing of the open side of the gastrula, which is turned toward the injured cell, is chiefly accomplished by the overgrowth of the ectoderm cells of the ventral side. (Fig. 31.)

Except, therefore, for this tendency of the cells along the injured side to come together, these half gastrulæ are strictly partial and the gastrulation no less than the cleavage may be regarded as an illustration of mosaic development.

## RIGHT OR LEFT HALF EMBRYOS; 64-CELLS TO GASTRULA.

Figs. 25, 26. Fixed and stained half embryos; spurted in the 2-cell stage and fixed 2 hours later. Fig. 25. Right half of 64-76-cell stage, dorsal view. The neural plate cells ( $A^{8.7}$ ,  $A^{8.8}$ ,  $A^{8.15}$ ,  $A^{8.16}$ ) have just divided, the chorda cells ( $A^{7.3}$ ,  $A^{7.7}$ ) are dividing. The position of the cells  $A^{7.1}$ ,  $A^{7.2}$  is slightly abnormal. (v. Fig. 6.) Fig. 26. Left half of 64-76-cell stage, ventral-posterior view.

Figs. 27, 28. Right half of embryo in about 180-cell stage; spurted in the 4-cell stage and fixed 2½ hours later. Fig. 27. Dorsal view; the large endoderm cells lie above the level of the other cells and form an exogastrula; some of the yellow cells (stippled) still lie at the surface while others are covered by endoderm cells. Fig. 28. Ventral view of similar embryo.

Figs. 29, 30. Living right half embryos, dorsal view, showing the endoderm cells forming exogastrula and the yellow crescent cells at the surface.

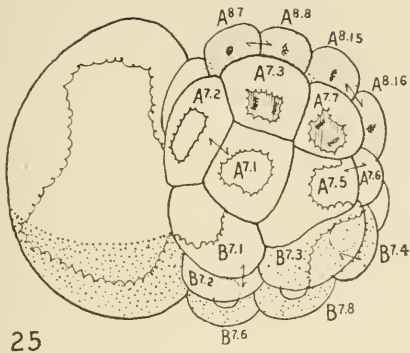

25

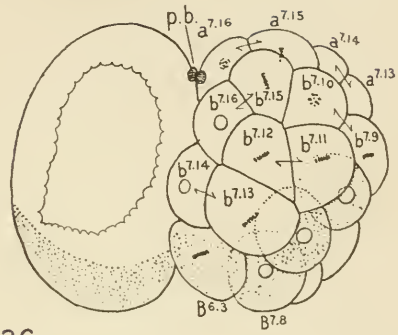

26

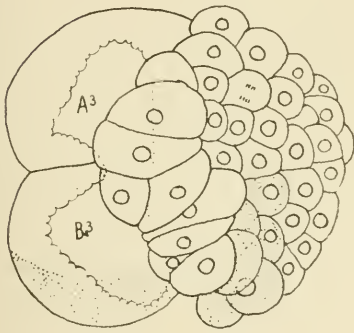

27

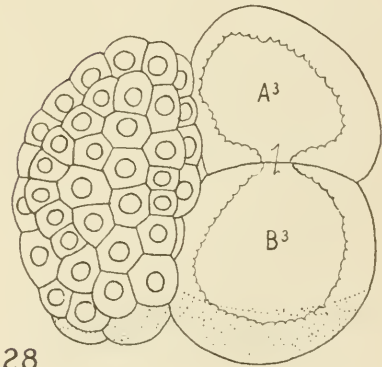

28

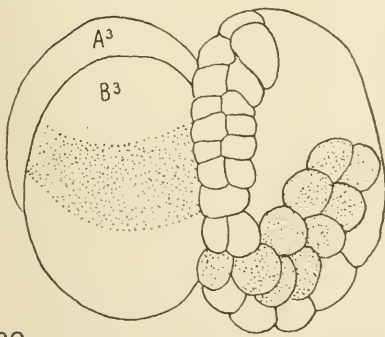

29

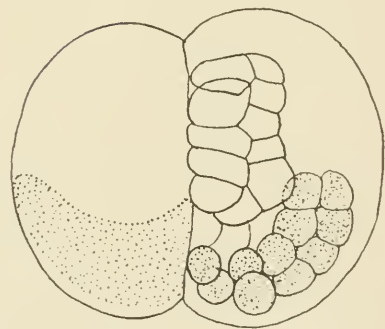

30

RIGHT OR LEFT HALF OR THREE-QUARTER EMBRYOS; GASTRULA TO TADPOLE. DRAWN FROM  
FIXED AND STAINED MATERIAL.

Fig. 31. Right half gastrula of about 220-cell stage; spurted in the 4-cell stage and fixed 3 hours later. The neural plate, chorda and mesoderm cells are present only on the right side and in their normal positions and numbers.

Fig. 32. Left half of young tadpole, dorsal view; spurted in the 4-cell stage, fixed 5 hours later. The notochord is normal except for size and number of cells; the muscle and mesenchyme cells are present only on one side; the neural plate is abnormal in form but not in position.

Fig. 33. Right half of young tadpole, dorsal view; spurted in the 4-cell stage, fixed 4½ hours later (slightly younger stage than Fig. 32). The notochord consists of a small number of cells which are interdigitating; muscle cells and mesenchyme lie on the right side of the notochord, but not on the left, though the muscle cells have begun to grow around to the left side; the neural plate is normal in position but not in form.

Fig. 34. Right-posterior three-quarter embryo, from the right side. The left anterior cells ( $A^{4,1}$ ,  $a^{4,2}$ ) were killed in the 8-cell stage and the embryo fixed 5 hours later. The posterior half of the embryo is normal, but the left half of the anterior part is lacking and the neural plate is abnormal and has not formed a tube though sense spots are present.

Fig. 35. Left-anterior three-quarter embryo, dorsal view; the right posterior quadrant ( $B^3$ ) was killed in the 4-cell stage and the embryo fixed 6 hours later. The anterior half of the embryo is entirely normal. The muscle cells are lacking on the right side though they have begun to grow around the hinder end of the notochord. The posterior portion of the trunk mesenchyme is found only on the left side, but its anterior portion, which is derived from the cells  $A^{7,6}$  and  $A^{7,8}$  (Fig. 6) of the anterior quadrants is present on both sides. In the region of the injured cell the notochord and neural tube are curved away from that cell.

Fig. 36. Left half embryo, from left side; spurted in the 4-cell stage, fixed 6 hours later. The dorsal lip of the blastopore is being overgrown by the ventral (posterior) lip. Muscle cells and mesenchyme are found only on the left side. The neural plate is abnormally folded, but still open; sense spots are present.



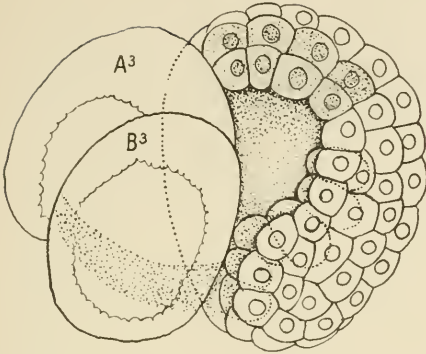

31

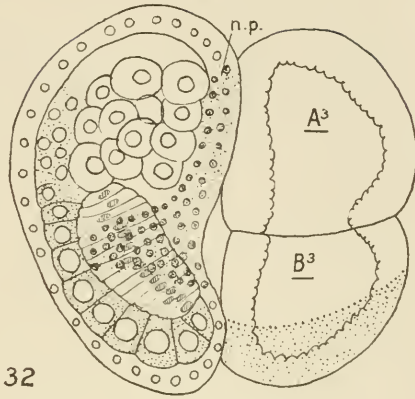

32

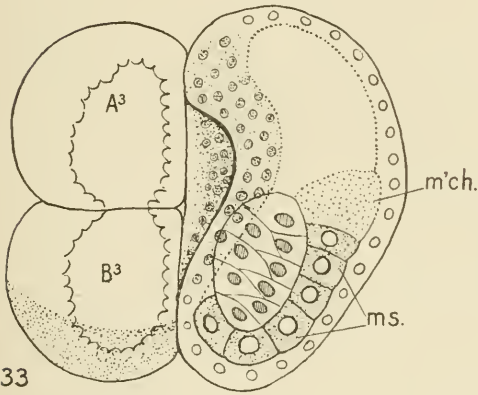

33

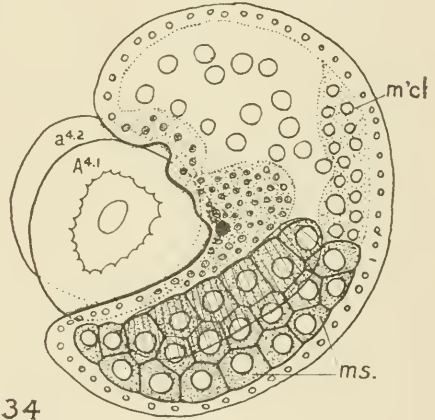

34

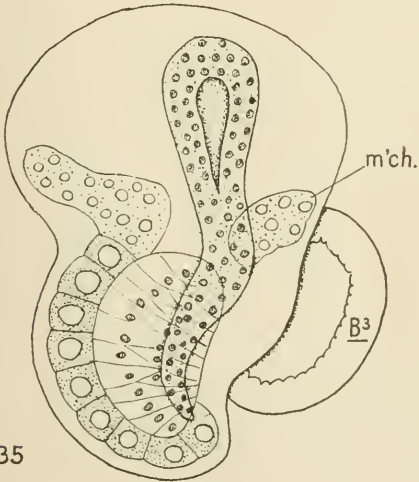

35

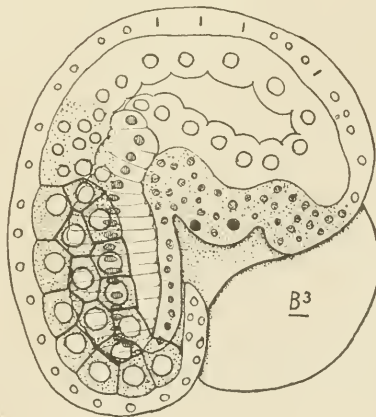

36

## c. Formation of Larva.

A considerably later stage in the development of the half embryo is shown in Figs. 32, 33 and 36 (Figs. 34 and 35 are three-quarter embryos and will be described later); of these stages Fig. 33 is the youngest and Fig. 36 the oldest. In all of these figures the blastopore has already closed and the chorda cells have given rise to a fusiform notochord, which lies in the posterior half of the embryo. The blastopore closes chiefly by the posterior growth of the dorsal (anterior) lip, as in the normal gastrula. With the formation of the notochord the posterior half of the embryo becomes elongated and narrower than the anterior half and the developing tail bends around toward the injured side. (Figs. 32, 33.)

The anterior half remains large, the posterior half becomes long and narrow; the latter portion contains the notochord and muscle cells, the former the gastral endoderm, mesenchyme and most of the neural plate. The general superficial appearance of an embryo of this stage is very similar to a normal one, but a more detailed study shows many differences.

(1) *Neural Plate.* The neural plate occupies in the main its normal position, that is, it lies along the first cleavage plane on the dorsal side, next to the injured cell. In this position the plate becomes folded and ultimately comes to contain a vesicle (the sense vesicle) though the steps by which this vesicle is formed are always irregular and abnormal. (Figs. 36-40.) The anterior portion of the plate is usually doubled over posteriorly while the posterior portion is folded forward (Figs. 36, 39, 40) and in this way a vesicle is finally formed.

The tail of the embryo grows around toward the injured side so that the concave side of the embryo is median or dorsal, the convex side being lateral or ventral. In the younger, normal larvæ the concave side is ventral, the convex dorsal. In these half larvæ the nerve plate lies along the concave side, a condition which is the reverse of what is found in the normal larva. (*cf.* Figs. 12 and 36.) In the older half larvæ there is almost always found one or more pigmented sense spots in the neural plate or sense vesicle. (Figs. 36-40, 45, 46.) These pigment spots appear within cells of the neural plate and, as I am well convinced, always within definite cells, though owing to the abnormal foldings of the neural plate they do not always occupy exactly the same

positions. Furthermore these sense spots may be more numerous than in the normal larva, as shown in Figs. 45 and 46, probably owing to the fact that the cells which form the pigment and which normally lie on the margins of the neural plate do not come together to form two spots as in normal larvæ, but remain separated so that several such spots are formed.

(2) *Notochord*. The chorda cells grow back into the posterior half of the embryo and the cells here interdigitate in the normal manner, finally forming a linear series of cells. (Figs. 32-46.) The notochord, which is at first relatively short and thick, Fig. 33, becomes later very much longer and more slender, Fig. 40, and in all respects it has the appearance of a normal notochord, save that it evidently contains a smaller number of cells. The position of the notochord of the half larva is always slightly abnormal; it never lies along the original median plane (first cleavage) as in normal larvæ, but its anterior end is diverted away from that plane and toward the lateral border of the larva. (Figs. 32, 33, 37, 41.) This position is that which the chorda cells, which arise in the anterior lip of the blastopore and which grow posteriorly around the margin of the blastopore, would naturally assume. (*cf.* Figs. 31 and 33.) What it is which causes the chorda cells to interdigitate in their characteristic manner is a question difficult to answer; it certainly is not dependent upon the crowding together of chorda cells from the right and left sides since it occurs normally when the cells of one side only are present; on the other hand it must depend upon a certain amount of lateral compression of the chorda cells since it occurs very rarely if at all in the anterior half larvæ in which the ectoderm and mesoderm of the tail are lacking.

(3) *Muscles and Mesenchyme*. In these right or left half embryos and larvæ the muscle and mesenchyme cells are present on one side of the notochord; here they occupy their normal positions, the muscle cells giving rise to three rows of cells along the lateral border of the notochord and the mesenchyme forming a group of small cells anterior to the muscle rows. (Figs. 32, 33, 36.) In later stages the muscle cells slowly extend over to the side of the tail on which they were originally lacking; this takes place especially at the hinder end of the tail, the overgrowth taking place around the end of the notochord and over its ventral side. In this way the right or left half embryo or larva tends to become complete, but I have never seen a case in which three rows of muscle

cells were found on both sides of the notochord. Indeed, I am not at all sure that this extension of the muscle cells around the end of the notochord is accompanied by any increase whatever in the number of muscle cells or in the number of rows of cells. The latest stage in which I can positively identify the three rows of muscle cells is shown in Fig. 36. In this larva the muscle rows lie nearer the ventral side than in normal larvæ (see Fig. 12), and they are evidently extending over the ventral surface toward the opposite side. In later stages the muscle cells become much elongated, but I have not been able to determine the number of rows present. I have found it still more difficult to decide whether the trunk mesenchyme ever extends over to the side on which it was originally lacking, but I believe that this takes place only to a limited extent, if at all, and that Chabry was right when he affirmed that only one atrial invagination is formed in these right or left half embryos.

## 2. *Three-Quarter Embryos (Figs. 34-35).*

In connection with the right or left half embryos I shall here consider three-quarter embryos, which, of course, include the whole of the right or left half. Two such embryos are shown in Figs. 34 and 35. In the former the left anterior quadrant was killed in the 8-cell stage; in the latter the right posterior quadrant in the 4-cell stage. The embryo in which the cells of the anterior quadrants were uninjured (Fig. 35) is perfectly normal in its anterior half; its posterior half, however, lacks those parts which would have developed from the cell which was injured. This embryo is younger than the one shown in Fig. 34 and no sense spots are present, but the sense vesicle is closing in a normal manner. This figure well shows that a part of the trunk mesenchyme is derived from the anterior quadrants, and indeed from the pair of cells  $A^{7,6}$ , Fig. 6, while a portion of it comes from the posterior quadrants, as may be seen by comparing the right and left sides of Fig. 35. The muscle cells are entirely lacking on the right side, the substance which would have formed them being located in the injured cell  $B^3$ ; they are shown growing around the end of the notochord as in the half embryo shown in Fig. 33. The notochord and nerve tube are apparently full sized, which is explained by the fact that they come from the anterior quadrants, but owing to the lack of the right side of the tail they are somewhat distorted in form.

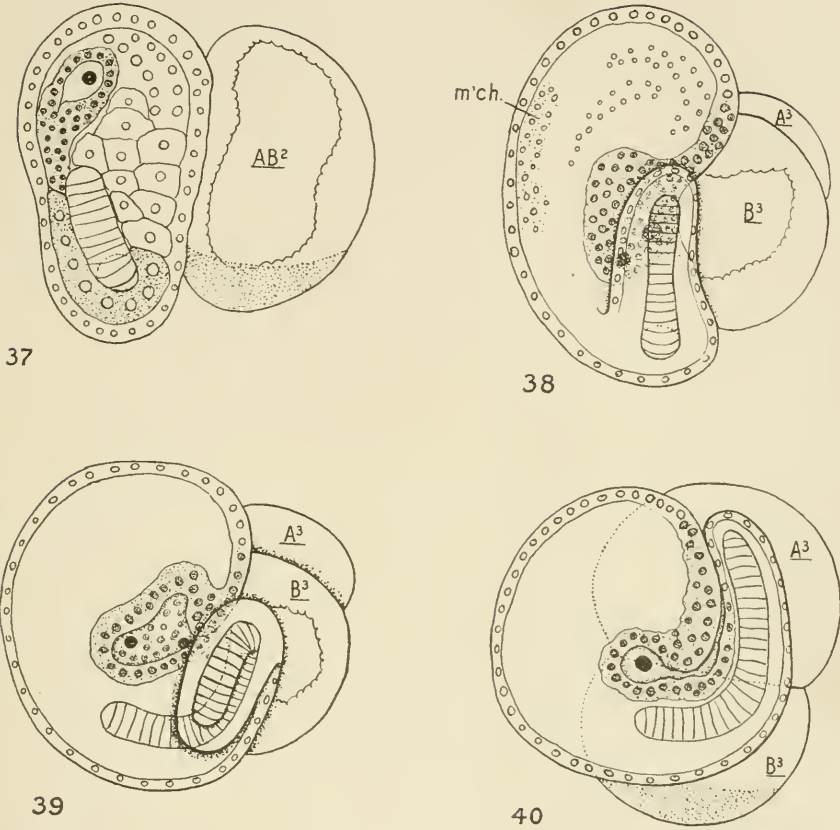

RIGHT OR LEFT HALF LARVAE. FIXED AND STAINED MATERIAL.

Figs. 37-40. Four half larvæ from eggs which were spurted in the 2-cell or 4-cell stage and fixed 22 hours later. These larvæ are still within the egg membranes though at a corresponding age normal larvæ are undergoing metamorphosis.

Fig. 37. Right half larva, ventral view. The tail which is elongated is turned down toward the dorsal side; the sense vesicle also lies on the dorsal side and is here seen through the embryo. The muscle cells are chiefly on one side of the notochord but have grown over to the other side at the posterior end.

Fig. 38. Left half larva, dorsal view. The neural plate with sense spots is partly covered by the end of the tail. The mesenchyme is found only on the left side.

Fig. 39. Left half larva from the left side. The neural plate is folded so as to form a nearly closed sense vesicle, in which are two sense spots.

Fig. 40. Left half larva viewed from the left side. The neural plate is partially closed, but is abnormal in form. In all of these larvæ the neural plate lies on the concave side.

RIGHT OR LEFT HALF LARVAE DRAWN FROM LIVING SPECIMENS FROM 12 HOURS (FIGS. 41, 42) TO 20 HOURS (FIGS. 45, 46) AFTER THE INJURY OF ONE OF THE FIRST TWO BLASTOMERES.

Fig. 41. Posterior-dorsal view. Fig. 42. Same embryo, posterior ventral view. In both these figures the muscle cells are found chiefly on one side of the notochord, but they have grown over to the opposite side at the end of the tail. Fig. 43. Right half larva from right side. Fig. 44. Left half larva from left dorsal side. The yellow crescent on the injured blastomere apparently occupies different positions with respect to the larva in these two figures, but it is by no means certain that the convex side of the larva is morphologically the same in the two figures.

Figs. 45, 46. Two views of one and the same left half larva. Fig. 45, from the dorsal side; Fig. 46, from the left side, showing two sense spots on the dorsal and two on the ventral sides. The neural plate is continuous between these spots on the side next to the injured blastomere.

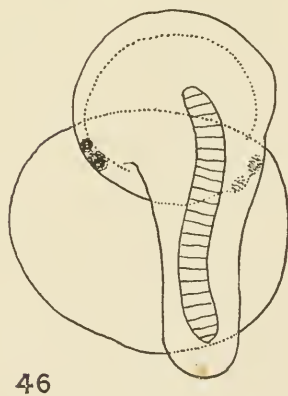
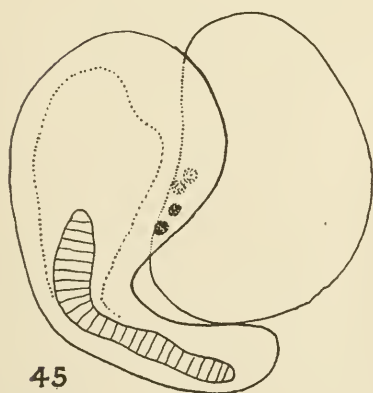
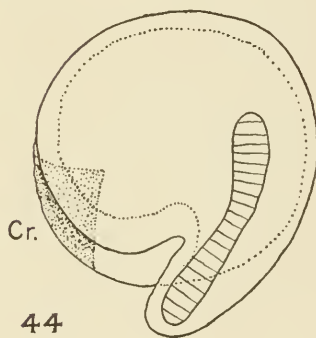
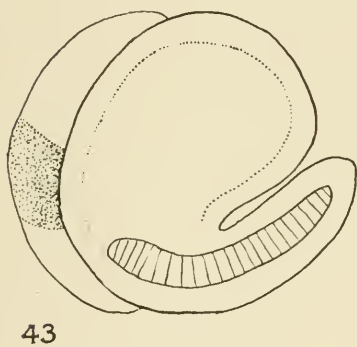
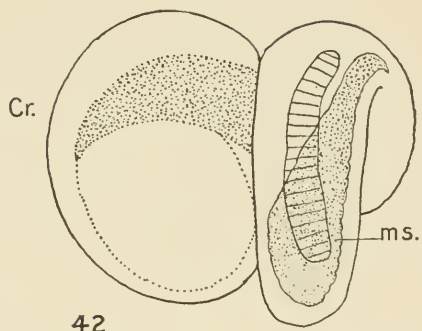
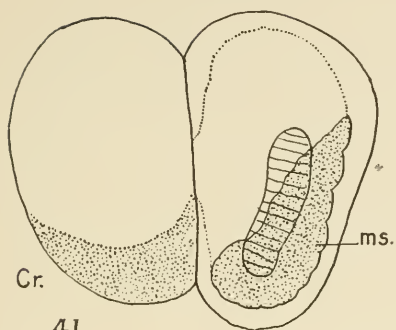

In Fig. 34 the left anterior quadrant was killed and the posterior portion of this embryo is normal save only for the fact that the notochord and nerve tube are smaller than usual, which is explained by the fact that the substance of these organs is derived from the anterior quadrants; three rows of muscle cells are found on both sides of the tail. The anterior half of this embryo, on the other hand, is quite defective; the neural plate is irregularly folded and has not formed a sense vesicle, although sense spots are present.

I have seen and studied many three-quarter embryos similar to those shown in Figs. 34 and 35 and they all show, as do the right and left half embryos, that where part of the substance which would normally form an organ is destroyed the organ which develops is defective, whereas if all or any organ-forming substance is lacking the organ to which it would normally give rise is also lacking.

So far as I have observed these partial larvæ never escape from the egg membrane, and in this my observations accord with those of Chabry and Driesch, and although I have kept them alive until a period after the normal larvæ have undergone metamorphosis I have never observed this transformation in them.

In conclusion then I find that the cleavage and gastrulation of these half or three-quarter embryos is partial and the resulting larva incomplete although the notochord is well formed and there is a tendency on the part of some of the cells to grow over and close up the open side of the larva. However, this regulation never leads to the formation of a complete larva; the neural plate may close, but it forms an abnormal sense vesicle; at the end of the tail the muscle cells extend over toward the injured side, but they do not form three rows of cells on each side of the notochord as in the normal larva; the mesenchyme likewise does not develop along the injured side and it is probable that only one atrial invagination is formed.

Furthermore *not a single cleavage cell nor any one of the oöplasmic substances ever gives rise to parts or organs which it would not normally produce; the notochord, for example, invariably comes from the chorda cells, the sense vesicle from the neural plate cells and both these structures from the material of the gray crescent; the muscles always come from the muscle cells and these from the substance of the yellow crescent; the ectoderm, from the ectoderm cells and ultimately from the clear protoplasm; the endoderm, from the*



*endoderm cells and these from the deep gray material of the egg.* In spite therefore of the regulation which is apparent in the closing of the open side of the embryo, and in the formation of a whole notochord and of an imperfect sense vesicle, the various oöplasmic substances of the unsegmented egg and of the different blastomeres are not totipotent but each shows in these experiments, as well as in normal development, that it is differentiated to give rise to one, and only one, particular kind of tissue.

### 3. *Anterior Half Embryos (Figs. 47-52).*

The anterior and posterior half embryos show even more clearly than do the lateral ones the mosaic character of the development of these eggs. When the posterior half of an egg is killed in the 4-cell or 8-cell stage the anterior half continues to develop as if the posterior half were still living. The cleavage is in all respects like that of the anterior half of a normal egg; the gastrulation is essentially the same, but the later development is modified in many important particulars.

Figs. 47 and 48 are ventral and dorsal views, respectively, of one and the same living embryo of the 76-cell stage, in which the posterior dorsal cells,  $B^{4.1}$ , containing the yellow crescent, were killed in the 8-cell stage. None of the cells of the ventral hemisphere were injured and consequently the cleavage of these cells is quite normal; thirty-two ectoderm cells are present, all of which have entirely normal positions, shapes and sizes. (*cf.* Figs. 5 and 47.) The anterior half of the dorsal hemisphere is also entirely normal (*cf.* Figs. 6 and 48); eight chorda cells are shown forming an arc which bounds anteriorly the six endoderm cells and which is flanked on each side by the anterior mesenchyme cell,  $A^{7.6}$ . The number, size and position of each and all of these cells is the exact counterpart of what is found in the normal embryo, and, although the outlines of the neural plate cells were so indistinct in the living specimen from which this figure was made that I could not draw them, there is every reason to suppose that these cells like all the others in this embryo conform to the normal type.

In the posterior half of the dorsal hemisphere all the parts which would have developed from the cells  $B^{4.1}$  and  $B^{4.1}$  are entirely lacking; there are neither mesenchyme, caudal endoderm,

## ANTERIOR HALF AND THREE-QUARTER EMBRYOS; 76 CELLS TO METAMORPHOSIS.

Figs. 47, 48. Anterior-ventral three-quarter embryo of the 76-cell stage (*v.* Figs. 5 and 6); the dorsal posterior cells B<sup>1,1</sup>, containing all of the yellow crescent, were killed in the 8-cell stage. The ventral ectoderm cells (Fig. 47) are quite normal both in position and number (*cf.* Figs. 5 and 47); the anterior dorsal cells are also normal, but the posterior dorsal cells (muscle, mesenchyme and caudal endoderm) are entirely lacking. (*cf.* Figs. 6 and 48.)

Figs. 49-51. Three views of one and the same anterior half embryo of about the 250-cell stage; spurted in the 4-cell stage and fixed 2 hours later. Fig. 49. Dorsal view, superficial focus, showing the neural plate. Fig. 50. Dorsal view, deeper focus, showing two rows of chorda cells besides several ectoderm and endoderm cells. Fig. 51. Dorsal view, still deeper focus, showing the cells of the ventral ectoderm.

Fig. 52. Anterior half embryo, dorsal view. Spurted in the 4-cell stage, fixed 22 hours later. The yellow crescent is plainly visible in the injured cells. Sense spots are present but the neural plate never forms a tube. The chorda cells lie in a heap at the left side. There is no trace of muscle substance or of a tail in this anterior half embryo. This embryo is from the same experiment as Figs. 37-40; normal larvæ of this stage are undergoing metamorphosis.

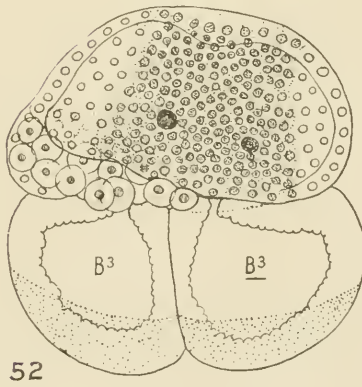
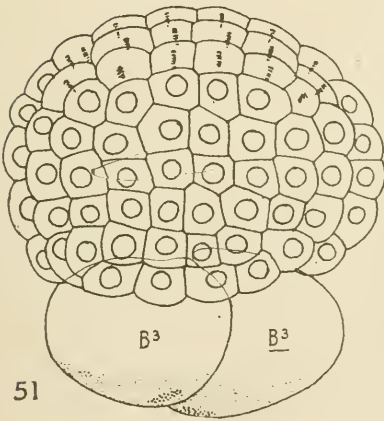
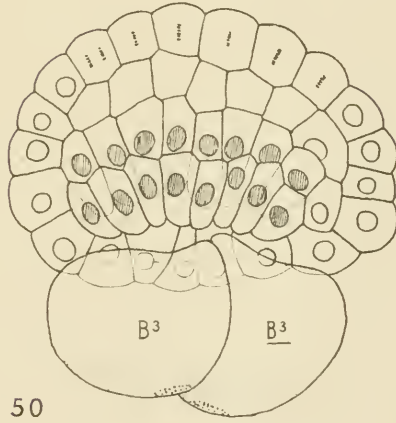
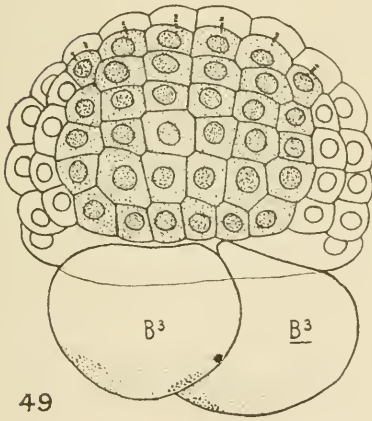
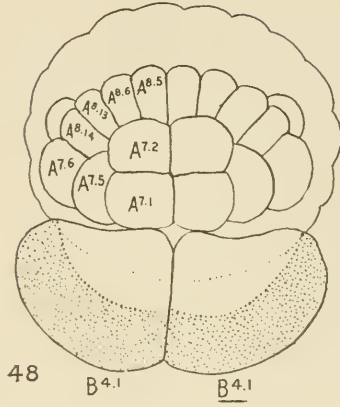
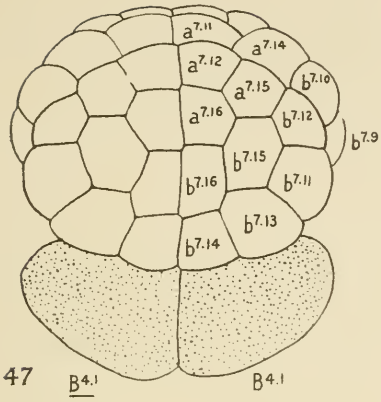

nor muscle cells. Unfortunately this particular embryo was not followed through the various stages of development until it gave rise to a larva and none of the older stages which I have studied have shown precisely this type of injury, *i. e.*, the destruction of the yellow crescent without injury to the ectoderm cells of the posterior half.

In many other cases which I have seen all of the posterior half of the egg was injured in the 4-cell stage. I have followed the development of the surviving anterior halves of such eggs as late as the stage of the metamorphosis of the normal larvæ; the development of such blastomeres is always partial. Figs. 49, 50 and 51 represent three views of one and the same anterior half embryo of about the 250-cell stage; in all the figures the embryo is viewed from the dorsal side, but in Fig. 49 the focus is high and only the ectoderm and neural plate cells of the dorsal surface are shown; Fig. 50 is a median optical section showing chorda and endoderm cells surrounded on the anterior side by ectoderm; Fig. 51 represents the ectoderm of the ventral surface which is visible at a deep focus. This half embryo is exactly like the anterior half of a normal one in the formation of the neural plate, the chorda plate, the general ectoderm and gastral endoderm, in the overgrowth of the dorsal lip of the blastopore, even in the position, shape and size of the individual cells. (*cf.* Figs. 9 and 10.)

Finally in Fig. 52 there is represented an anterior half embryo 22 hours after the posterior cells were killed, and at a stage when normal larvæ of corresponding age have already undergone metamorphosis. The ectoderm has not yet inclosed the embryo on the side next the injured cells, and this rarely happens in anterior or posterior half embryos. The neural plate has not rolled up nor invaginated to form a tube, though it is slightly depressed along its median line; two sense spots are present though there is no sense vesicle. The large rounded chorda cells are irregularly scattered along the posterior border of the embryo, where they project beyond the ectoderm; they never form a notochord. There is no trace of yellow crescent substance nor of muscle cells in these anterior larvæ and no indication whatever of a tail. They are, therefore, altogether unlike the normal larvæ and they afford complete and convincing evidence that the anterior blastomeres of the ascidian egg are not totipotent but rather that the development is a mosaic work.

4. *Posterior Half Embryos (Figs. 53-58).*

All that has been said of the mosaic-like development of the anterior half of the egg is equally true of the posterior half. The cleavage progresses in normal fashion up to the time of the closure of the blastopore. Figs. 53 and 54 represent posterior half embryos of the 32-cell and 76-cell stages, respectively. The former is entirely normal and the latter is normal in all respects save that a single pair of cells, B<sup>8,9</sup>, is larger than in the normal embryo. The clear, the yellow and the gray substances of the egg are distributed exactly as in the posterior half of a normal embryo. The clear ectoderm cells lie on the ventral side and only two of them appear in the dorsal view shown in Fig. 54 (the two clear cells at the posterior pole). In Fig. 53 the gray endoplasm is contained in two cells (B<sup>6,1</sup>) and in Fig. 54, in four (B<sup>7,1</sup>, B<sup>7,2</sup>); these cells give rise to the strand of caudal endoderm. The yellow crescent consists at the 32-cell stage of a single arc of yellow cells (Fig. 53) which then, by division, become a double arc of fourteen cells (Fig. 54); the inner arc consists of eight mesenchyme cells and the outer of six muscle cells. In all these respects these posterior half embryos are entirely like the posterior half of a normal embryo.

But while the pregastrular stages of these posterior half embryos are like the normal, the gastrulæ and later stages show many interesting modifications. Figs. 55, 56, 57 are three views of one and the same posterior half embryo, the normal embryos of the same stage being young tadpoles like Fig. 11. In all of these figures the embryo is viewed from the dorsal side; Fig. 55 shows the ectoderm cells which cover the dorsal surface; Fig. 56, the muscle cells which lie below the ectoderm on the dorsal side; Fig. 57 is an optical section at a still deeper level showing the caudal endoderm and mesenchyme. Fig. 58 is another posterior half embryo of similar age seen from the ventral side, showing the yellow mesoderm cells on each side of the caudal endoderm.

The gastrulation occurs between the stages shown in Figs. 54 and 55. The caudal endoderm and the surrounding arc of mesenchyme, shown in Fig. 54, invaginates; the muscle cells come to lie above (dorsal to) the mesenchyme cells and finally the latter are overgrown by the ectoderm in the manner shown in Fig. 8. In normal embryos the posterior part of the blastopore is closed chiefly by the growth of the anterior lip; in the latter stages of

## POSTERIOR HALF EMBRYOS; 32 CELLS TO TADPOLE STAGE. FIXED AND STAINED PREPARATIONS.

Fig. 53. Posterior half of 32-cell stage, dorsal view. The cleavage is altogether normal. Spurred in the 4-cell stage, fixed 1 hour later.

Fig. 54. Posterior half of 76-cell stage (*cf.* Fig. 6); spurred in the 4-cell stage, fixed 2 hours later. Two rows of yellow crescent cells are present, the inner being mesenchyme, the outer muscle cells; the anterior pair of mesenchyme cells ( $B^{8.6}$ ) are larger than normal. There are two pairs of caudal endoderm cells ( $B^{7.1}$  and  $B^{7.2}$ ). A pair of ventral ectoderm cells is visible in the midline behind.

Figs. 55-57. Three views of one and the same embryo; spurred in the 4-cell stage, fixed 4 hours later, normal embryos being in the stage represented by Fig. 11. Fig. 55. Dorsal view of the superficial ectoderm. The notch in front represents the notch in the ventral lip of the blastopore. Fig. 56. Same view, deeper focus, showing the muscle cells beneath the ectoderm; these cells are continuous from side to side, there being no chorda in the midline. Fig. 57. Same view, still deeper focus, showing the double row of ventral endoderm cells in the midline, and on each side of this a mass of mesenchyme cells.

Fig. 58. Ventral view of posterior half embryo of the same stage as the preceding, showing the muscle and mesenchyme cells beneath the ectoderm and on each side of the strand of ventral endoderm.

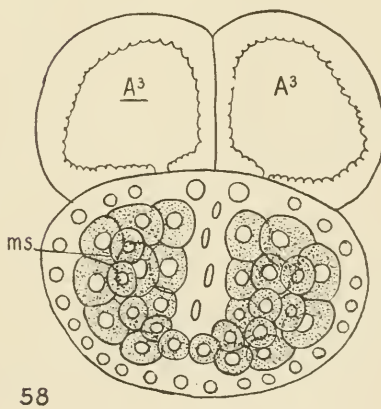
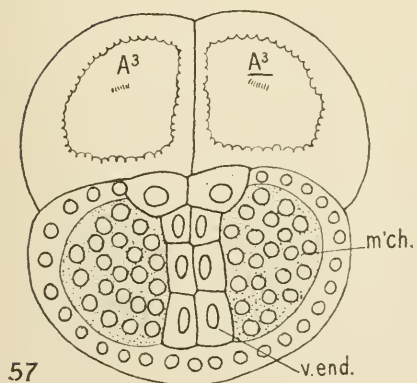
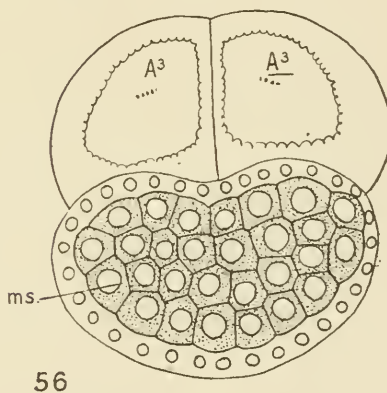
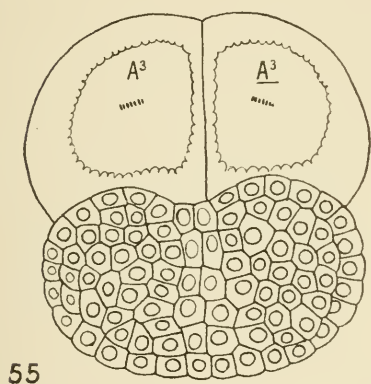
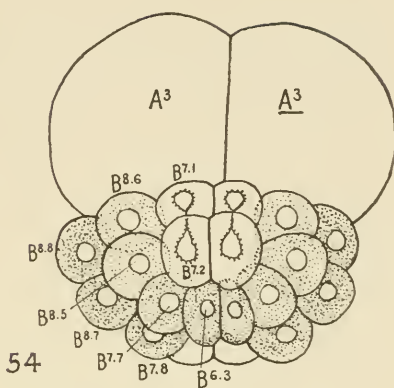
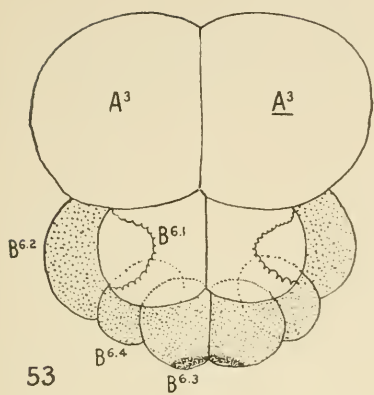

gastrulation a blastopore groove is left in the posterior half of the embryo, on each side of which lie the muscle cells. (Fig. 9.) By the continued growth of the anterior lip this groove is shoved to the posterior end of the embryo and the rows of muscle cells are tilted up from an antero-posterior to a vertical position. Later, when the notochord is formed, the muscle cells come to lie alongside of it, thus forming the three rows of muscle cells on each side. Finally the ectoderm of the posterior lip of the blastopore, which has, up to this stage, formed a notch at the end of the blastopore groove, grows forward and reduces this groove to a minute pore.

Owing to the absence of the anterior lip of the blastopore, and of the notochord and the neural plate, the later stages in the development of these posterior half embryos is much altered. In the first place the blastopore groove and the muscle cells are not pushed to the posterior end of the embryo. Then the muscle cells on each side of the blastopore groove are not kept apart by the notochord but come into contact forming a continuous layer of muscle cells across the dorsal side. (Fig. 56.) The blastopore groove, therefore, disappears by the fusion of the lateral lips of the groove and the ectoderm cells grow over the whole dorsal surface; the only trace of the blastopore groove which is left is a slight notch in the anterior border of the embryo. (Figs. 55, 56.) The ectoderm never entirely incloses the posterior half embryo on the side next to the injured cells, but the endoderm here comes to the surface as shown in Figs. 57 and 58.

No trace of notochord, neural plate nor sense spots ever appears in these posterior half embryos, and what is more remarkable a tail is never formed but the embryo always remains rounded in form, as shown in Figs. 55-58. It is quite evident that the elongation of the tail of the normal larva, together with the elongation of the individual muscle cells and perhaps also the arrangement of these cells in three rows on each side, is dependent upon the presence and elongation of the notochord. Perhaps one reason why a normal notochord is never formed in the anterior half embryo is due to the fact that the ectoderm does not completely inclose the embryo, so that the chorda cells in their growth crowd out of the open side and hence become free and scattered.

*In conclusion, the study of anterior or posterior half embryos establishes in a most convincing manner the fact that the development of individual blastomeres of the ascidian egg is a mosaic work.*



*These blastomeres give rise only to those tissues and parts of an embryo which would come from them normally. Nothing even remotely resembling a complete normal larva is ever produced from the anterior or posterior quadrants of the egg.*

#### 5. Quarter Embryos (Figs. 59-70).

The development of individual blastomeres of the 4-cell stage furnishes additional confirmation of the mosaic theory as applied to ascidian eggs; in every instance individual blastomeres give rise only to those parts or organs which they would produce in normal embryos. Quarter embryos generally show more abnormalities and variations than half embryos,—probably owing to the more severe injury which they have suffered, which often affects the surviving quarter of the egg.

The cleavage of these quarter eggs is normal in every detail, save that the position of the cells is sometimes slightly altered; the rhythm of cleavage and the size and quality of the cells is the same as in the corresponding quarter of a normal egg. In Fig. 59, which corresponds to the 16-cell stage of the normal egg, each of the surviving quadrants has divided twice; in Fig. 60 the left posterior quadrant of a 44-cell stage is shown and in both of these figures the size, quality and position of the cells as well as the rhythm of division and the distribution of the different oöplasmic substances is entirely normal. Fig. 61, which is the right anterior quadrant of the 76-cell stage, is normal in every respect, save for the position of the endoderm cells which are here displaced toward the first cleavage plane. The mesoderm cells in the right posterior quadrant, shown in Fig. 62, are not normal in position; the two caudal endoderm cells (lying next the first cleavage plane) are, however, normal and the ectoderm cells are normal save that they show a tendency to grow inward at the first and second cleavage furrows and thus surround the embryo. In particular, attention should be directed to the yellow crescent and caudal endoderm cells in Fig. 60, and to the neural plate and chorda arcs in Fig. 61, which are similar in every respect to the quarter of a normal embryo at these stages.

I have already commented upon the fact that the quarter embryo shown in Fig. 63 is a "false gastrula" since the invaginated cells are ectodermal, probably neural plate cells, while the larger endo-

## QUARTER EMBRYOS; 16 CELLS TO YOUNG TADPOLE STAGE. FIXED AND STAINED PREPARATIONS.

Fig. 59. Left anterior and right posterior (diagonal) quarter embryos of the 16-cell stage, ventral view.

Fig. 60. Left posterior quarter embryo of the 44-cell stage, posterior view.

Fig. 61. Right anterior quarter embryo of the 76-cell stage, dorsal view, showing the neural plate and chorda cells of the right side.

Fig. 62. Right posterior quarter embryo of about the 180-cell stage, dorsal view (*cf.* Figs. 7, 8); spurted in the 4-cell stage, fixed  $2\frac{1}{2}$  hours later, showing 6 muscle and 2 caudal endoderm cells.

Fig. 63. Left anterior quarter embryo, dorsal view; spurted in the 4-cell stage, fixed 5 hours later. An invagination of the ectoderm cells has the appearance of a gastrula, but is probably the invagination of the neural plate.

Fig. 64. Left anterior and right posterior (diagonal) quarter embryos, dorsal view; spurted in the 4-cell stage, fixed 5 hours later. Muscle cells are found only in the posterior quarter.

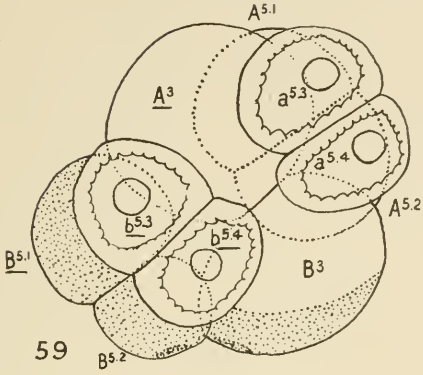

59

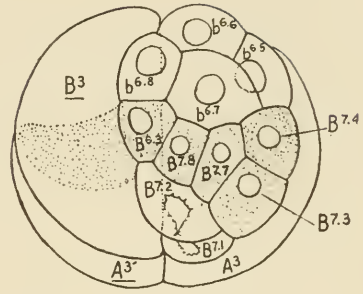

60

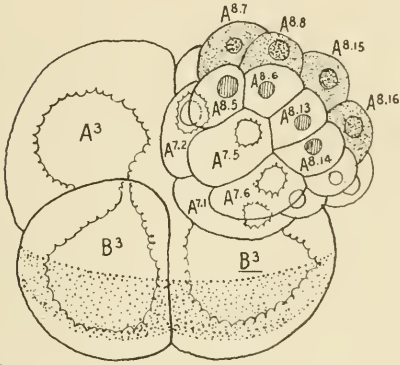

61

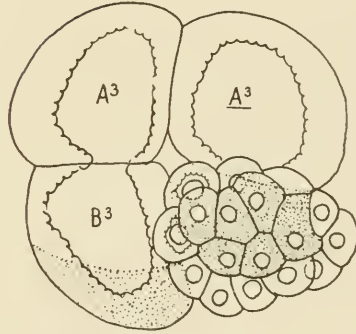

62

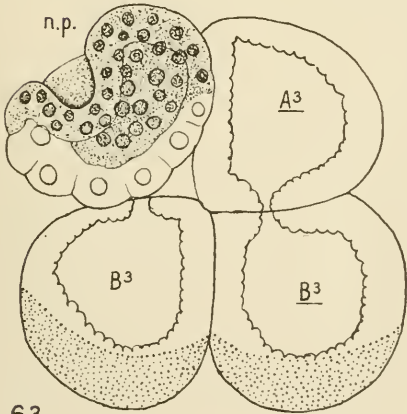

63

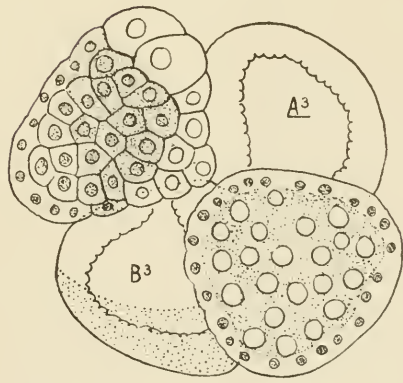

64

QUARTER EMBRYOS; YOUNG TADPOLE TO METAMORPHOSIS STAGES. FIXED AND STAINED PREPARATIONS.

Fig. 65. Left anterior and right posterior (diagonal) quarter embryos, dorsal view; spurted in the 4-cell stage, fixed 5 hours later. The anterior quarter shows thickened ectoderm cells, probably neural plate, around the endoderm cells; in the posterior quarter are 8 muscle and 3 caudal endoderm cells.

Fig. 66. Left anterior and right posterior (diagonal) quarter embryos from the right anterior side, the dorsal pole being above; spurted in the 4-cell stage, fixed 22 hours later. In the posterior quarter the muscle and mesenchyme cells form a solid mass; in the anterior quarter the chorda cells project freely over the dorsal surface and the neural plate is partially infolded and contains three sense spots.

Fig. 67. Right anterior and left posterior (diagonal) quarter embryos, dorsal view; spurted in 4-cell stage, fixed 22 hours later.

Fig. 68. Left anterior and right posterior (diagonal) quarter embryos, dorsal view; spurted in 4-cell stage, fixed 22 hours later. In this and the preceding figure the chorda cells (Ch.), neural plate (n. p.) and sense spots are found only in the anterior quarters; the muscle, mesenchyme and caudal endoderm cells, only in the posterior quarters.

Figs. 69, 70. Right anterior quarter embryos, dorsal side above; spurted in 4-cell stage, fixed 12 hours later. These embryos show free chorda cells, neural plate and sense spots, but not a trace of muscle cells.

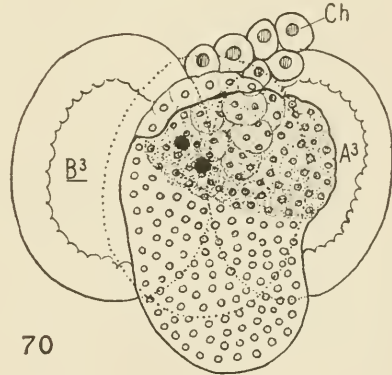
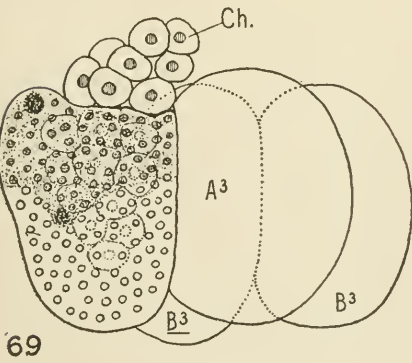
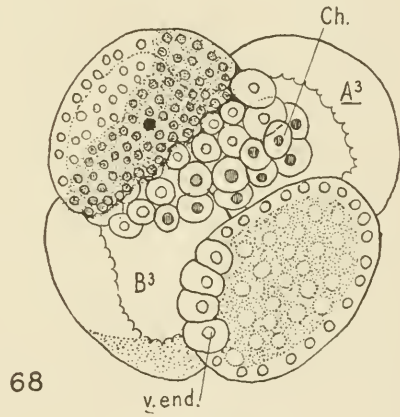
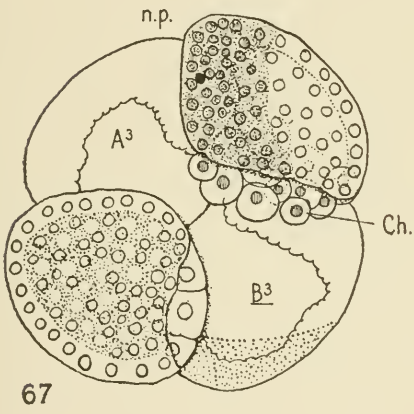
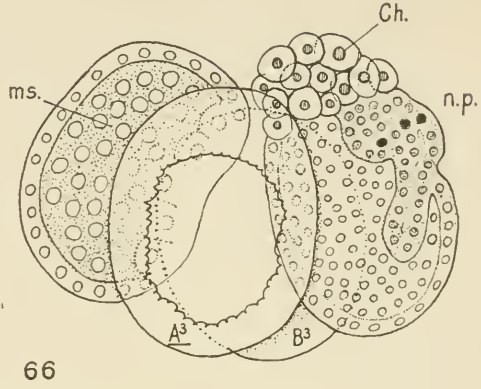
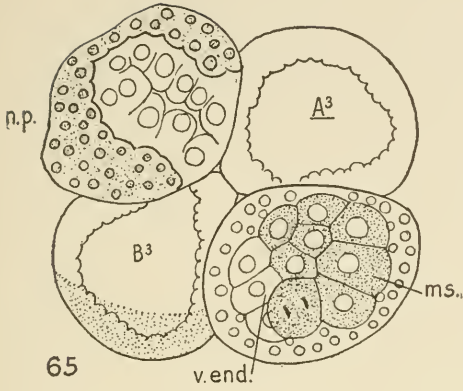

derm cells remain on the rounded surface of the embryo. I have not observed in detail the process of gastrulation in any of these quarter embryos, but it is evident that there is no considerable gastrula cavity and that the endoderm cells are chiefly overgrown by the ectoderm, as shown in Fig. 65. Ultimately the endoderm and mesoderm are largely overgrown, though in this case, as in the half embryos, the ectoderm does not entirely inclose the embryo on the side next to the injured cells and through the opening thus left some of the endoderm cells may protrude.

Although the localization of oöplasmic substances and of organ bases is usually the same as in the quarter of an entire embryo, in some cases there are dislocations of these substances and bases which are probably due to injury of the surviving quarter. Thus in the left anterior quarter, shown in Fig. 64, large endoderm cells lie at the surface next to the first cleavage plane; in the same quadrant of another egg shown in Fig. 65 the neural plate cells lie at the periphery of the quadrant and chiefly on the left side, instead of along the median plane as in normal embryos. I have seen many other instances of such dislocations but they are all of such nature that they can be interpreted as due to slight injury to the surviving blastomeres. In not a single instance are parts derived from a blastomere which would normally have come from another cell.

The anterior quarter embryos are always recognizable by the presence of the neural plate and, in later stages, of the sense spots. The neural plate usually remains at the surface and is not infolded, but in some cases it is invaginated through at least a portion of its area, though a sense vesicle is not formed. (Figs. 63, 66.) In all later stages one or more sense spots appear in the plate. (Figs. 66-70.) The neural plate always lies along the dorsal side of the embryo, though it may be shifted more or less from the median plane. (Figs. 65-70.) The chorda cells are found exclusively in the anterior quadrants and in later stages they protrude to the exterior along the injured side where they are found as scattered cells in the perivitelline space. (Figs. 66-70.) In no case, save one, have I seen any indication that these cells form a rod-shaped notochord, and this case (Fig. 72) was that of a living embryo in which it is possible that the notochord-like structure was really composed of gastral endoderm and hence not a true notochord at all. It is evident that the chorda cells are unable to give rise to a

notochord when once they have escaped and have become free, a certain amount of compression being necessary to bring about the characteristic interdigitation which leads to the formation of a rod-shaped notochord.<sup>1</sup>

The posterior quadrants can be distinguished in all eggs at all stages by the presence of the yellow crescent substance or cells. In early stages, as I have shown, these crescent cells are normal in position and character; in later stages the yellow cells fill the whole interior of the embryo. When once these cells have been inclosed by the ectoderm I have been unable to recognize any constancy in their position and arrangement. As in the posterior half embryos, a tail is never formed in these posterior quarter embryos and the muscle cells are never elongated, both these features evidently depending upon the presence of a notochord. The caudal endoderm cells are found in most, if not all, of these posterior quarter embryos as a single row of yolk laden cells which lie along the first cleavage plane (Figs. 65-68), the position which they normally occupy.

*These quarter embryos show in the most unmistakable manner that the development is strictly partial, and that an individual blastomere never gives rise to parts which it would not produce in the entire embryo. Among the hundreds of quarter embryos which I have studied both in the living condition and as stained and mounted preparations I have never seen a single one which even remotely resembled a normal larva.*

#### 6. Eighth or Sixteenth Embryos (Figs. 71-76).

When eggs are spurted or shaken in the 8-cell and 16-cell stages a great variety of abnormal forms are produced, a few of which are shown in Figs. 71 and 73-76. Without exception, however, the same principles apply here as in the case of half and quarter embryos, viz: a given blastomere or group of blastomeres produces only those parts of an embryo or larva which would develop from it under normal conditions. Fig. 71 represents an embryo derived from the dorsal anterior eighth of an egg (the cell  $A^{4.1}$ ) 14 hours after the injury. Normally this eighth gives rise to neural plate, chorda, gastral endoderm, and a small amount of

<sup>1</sup>Chabry, however, figures (his Fig. 18) a partial embryo with a rod-shaped notochord lying outside the embryo in the perivitelline space.

PARTIAL EMBRYOS FROM ISOLATED BLASTOMERES OF 8-CELL OR 16-CELL STAGES. DRAWN FROM LIVING SPECIMENS.

Fig. 71. Right anterior dorsal eighth embryo, 14 hours after injury, showing endoderm, chorda, and neural plate cells with sense spots.

Fig. 72. Right anterior quarter embryo, 14 hours after injury, showing chorda, neural plate, and sense spots.

Fig. 73. Posterior ventral quarter embryo derived from the cells  $b^{4.2}$ ,  $b^{4.2}$  and containing no endoderm and only a small amount of yellow protoplasm which was derived from the perinuclear plasm of the cells  $b^{4.2}$ , Fig. 13.

Fig. 74-76. Three views of a partial embryo derived from 7 cells of the 20-cell stage, viz: 2 ( $B^{5.2}$ ), 2 ( $b^{5.4}$ ), 1 ( $a^{5.4}$ ), 2 ( $a^{5.3}$ ). (cf. Figs. 3 and 4.) The embryo consists of an outer layer of clear ectoderm and of a mass of yellow mesenchyme cells derived from the cells  $B^{5.2}$ , but it is wholly without endoderm.

Fig. 74, Ventral view; Fig. 75, Posterior; Fig. 76, Postero-dorsal.



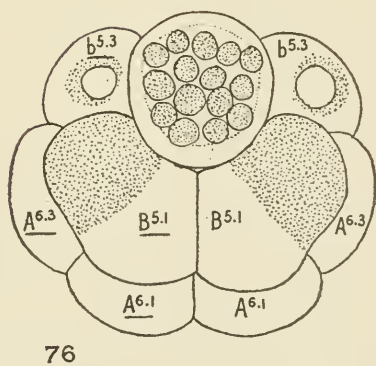
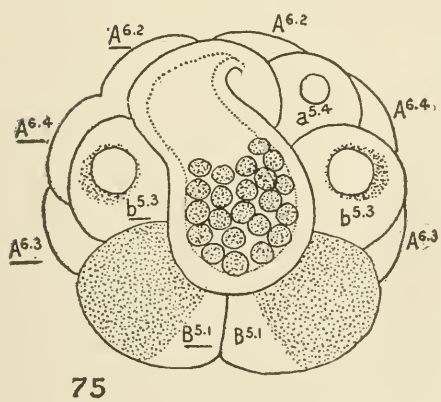
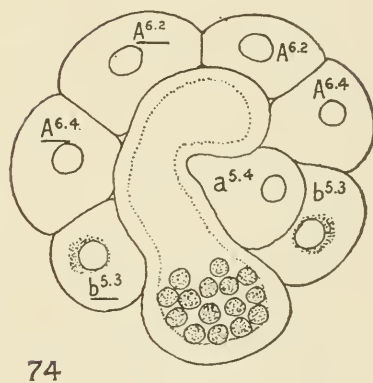
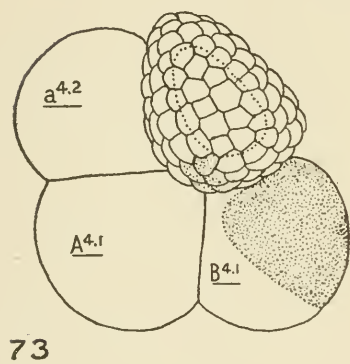
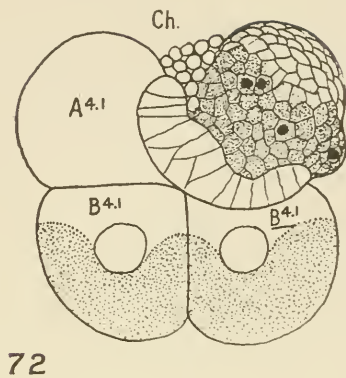
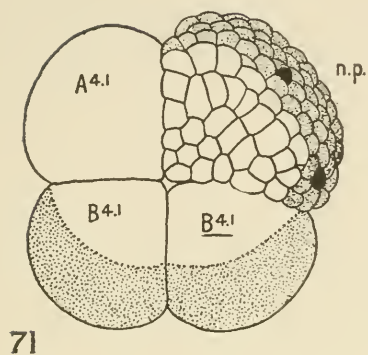

mesenchyme derived from the cell  $A^{7.6}$ . In the embryo shown in Fig. 71 the neural plate cells are clearly shown around the periphery of the figure and two of the cells clearly contain sense spots. The chorda, endoderm, and mesenchyme cells are shown internal to the neural plate, but I am unable to distinguish in this embryo between these three kinds of cells; they are all more or less yolk-laden as in the normal egg. Owing probably to the fact that no ventral ectoderm cells are present the neural plate is not pushed up onto the dorsal face and there are no evidences of gastrulation, although normal embryos of a corresponding age have already reached the full larval development. That this failure to gastrulate is not due to the slower development of the egg fragments as compared with the entire egg is shown by the degree of histological differentiation of the neural plate and sense spots, the latter appearing normally only in the fully formed larvæ.

Fig. 72 is a quarter embryo of the same age as the preceding, derived from the cells  $A^{4.1}$ ,  $a^{4.2}$  of the right anterior quadrant. The ventral ectoderm cells have here pushed the neural plate cells up onto the dorsal face of the embryo, while the chorda cells (?) lie along the median and transverse furrows. Four sense spots are present in the neural plate.

Fig. 73 is also a quarter embryo of the same age as the preceding, derived from the two posterior ventral cells  $b^{4.2}$ ,  $b^{4.2}$ . This embryo consists entirely of ectoderm which is arranged in a single layer of cells around a central cavity, the blastocoel. There has been no gastrulation and the embryo contains neither endoderm nor mesoderm. A few of the ectoderm cells next to the cell  $A^{4.1}$  contain yellow pigment, exactly as in the normal embryo.

Figs. 74 to 76 are three views of one embryo, about 20 hours after the egg was spurted in the 20-cell stage. By the spurting all the cells were killed except seven from which this embryo has developed, viz: a pair of mesenchyme cells  $B^{5.2}$ , and five ectoderm cells,  $b^{5.1}$ ,  $b^{5.1}$ ,  $a^{5.3}$ ,  $a^{5.3}$  and  $a^{5.4}$ . (See Fig. 3.) This embryo consists entirely of an outer layer of clear ectoderm cells, inclosing at its posterior end a mass of small mesenchyme cells; it contains no endoderm. It is an interesting fact that the mesenchyme cells are here inclosed by the ectoderm, showing that some process in the nature of gastrulation must have taken place.

A great many other partial embryos, produced from one or more blastomeres of the 8, 16 or 32-cell stages, have been studied

but they all illustrate the principle that a blastomere never gives rise to any other structures than those which it would produce in a normal embryo.

7. *Anterior and Posterior Half Gastrulæ (Figs. 77-82).*

In a recent publication Driesch ('03) has maintained that an alteration in the capacity for regulation occurs in the ascidian development between the early and the late gastrula stages. When the open cup-shaped gastrulæ of *Phallusia* were cut in two transversely into anterior and posterior halves, each of these halves developed into "einer vollständigen kleinen Appendicularie, welcher Organe niederer Bedeutung (Otolith, Augenfleck) eventuell fehlten." However, when the elongated gastrulæ were cut in two transversely a head developed from one piece and a tail from the other, "so deutlich und scharf begrenzt und ausgebildet, als habe man eine fertige Appendicularie scharf durchschnitten."

Considering the results which I have obtained on the development of the two anterior or two posterior cells of the 4-cell stage of *Cynthia* the conclusions of Driesch seemed most remarkable and I therefore undertook to repeat his experiments upon *Cynthia*. Gastrulæ of the stage shown in Fig. 8 were cut in two with a sharp knife made from a needle, under a Zeiss binocular dissecting microscope. With the power used the individual cells of the yellow crescent could be plainly seen and it was always easy to determine the exact boundary between the anterior and posterior halves. In every instance the section was made as close as possible to this boundary (second cleavage plane) and so as to leave all of the yellow cells in one of the pieces. Owing to the presence of the chorion the experiment was not an easy one to perform, since the chorion would frequently slip under the knife, or the egg move within the chorion. Nevertheless in one day I succeeded in cutting in two about thirty of these early gastrulæ; ten of these lived for twenty hours or longer after the operation, the others were too badly crushed to survive. Four of these which survived the operation are shown in Figs. 77-82, the drawings having been made from nineteen to twenty hours after the operation. Every one of these ten surviving embryos was a partial one and, although I was unable to determine their structure with the same amount of detail as in the case of stained and mounted preparations, it was

## ANTERIOR AND POSTERIOR HALF GASTRULAE.

Figs. 77-82. Partial embryos derived from gastrulae of the stage shown in Fig. 8, which were cut in two transversely so as to leave the whole of the yellow crescent in one half. The chorion is shown as a line around the embryos. Figs. 77, 78. Dorsal and ventral views respectively of one and the same embryo, drawn 19 hours after the operation. A mass of cellular debris lies between the two half embryos; the endoderm cells are chiefly contained in the anterior half, the mesenchyme and muscle cells are entirely confined to the posterior half. Neither half at all resembles a normal embryo or larva. Figs. 79, 80. Ventral and postero-dorsal views of another embryo, 19½ hours after the operation. The crescent of yellow cells is entirely confined to the posterior half and neither half resembles a normal larva. Fig. 81. Anterior and posterior half embryos 20 hours after the operation. Fig. 82. Posterior half embryo from the postero-dorsal side, 20 hours after the operation. The anterior half is degenerating and is shown only in dotted outline; the posterior half contains all of the yellow cells and practically no endoderm. At the stages represented by all these figures the normal embryos have already undergone their metamorphoses.

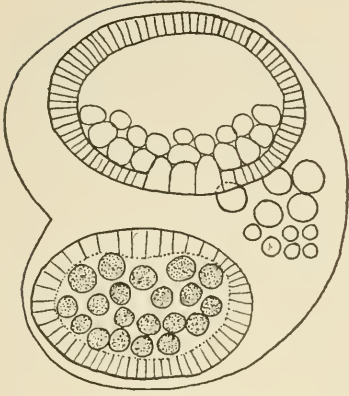

77

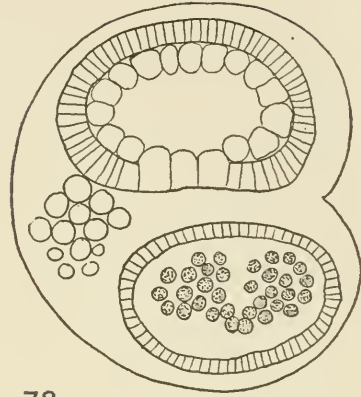

78

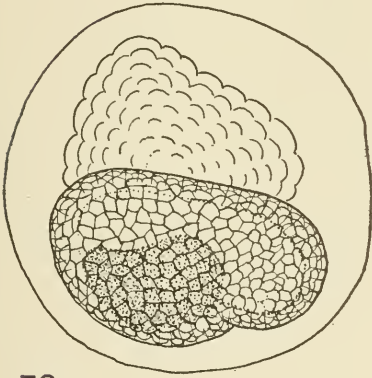

79

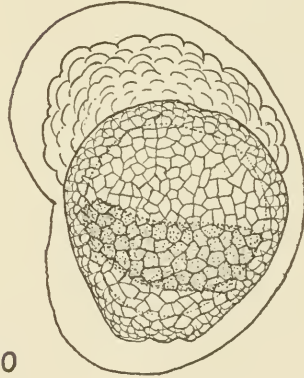

80

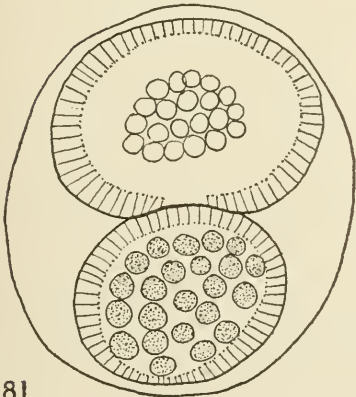

81

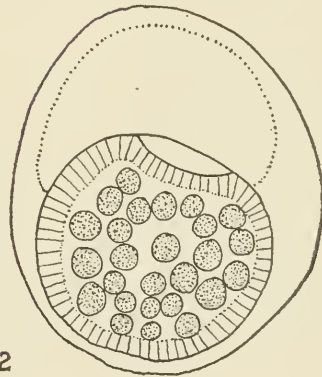

82

quite evident that not one of them resembled in any respect whatever a normal larva. In some cases both halves survived, as shown in Figs. 77-81, in other cases one half only survived. In all cases the surviving halves became rounded in form after the operation, the more seriously injured cells being crowded out of the embryo and forming a cellular mass of débris within the chorion. In every instance the surviving halves remained within the chorion, which was sometimes infolded as shown in Figs. 77-80. Each half was surrounded by a layer of clear ectoderm cells; the yellow cells were always found exclusively in the posterior half, the gray endoderm cells largely in the anterior half. Nothing resembling a notochord or neural tube ever developed in either half and no structure resembling a tail was ever formed. In fact these half embryos produced by cutting the early gastrulæ in two were altogether like the anterior and posterior half embryos which I have already described. (*cf.* Figs. 77-82 and Figs. 47-58.)

These results were so definite and conclusive that I did not continue the experiments and I regret now that I did not also cut gastrulæ in two along the median plane, though there is no reason to doubt that the results would be the same as in cases where one of the first two blastomeres is killed.

Comparing these results with those of Driesch, only one of two explanations is possible. Either *Phallusia* must differ most fundamentally from *Cynthia*, or Driesch must have mistaken the median for the transverse plane in these cup-shaped gastrulæ. That the former possibility is not probable is evidenced by the fact that the cell-lineage of all ascidians so far studied is essentially the same; furthermore my results as to the development of anterior and posterior halves of the egg of *Cynthia* are confirmed by my experiments on *Molgula*, as well as by Chabry's experiments on *Ascidia aspersa*. There is every reason to believe that what is true of these three genera is also true of *Phallusia*. On the other hand there are certain evidences that Driesch may have mistaken the transverse plane for the median; on p. 56 he says, "Aber auch an der Bechergastrula kann man die künftige Mediane und also auch die Hauptrichtungen senkrecht zu ihr unterschieden: es verlaufen nämlich die Zelltheilungsgrenzen des Ektoderms dieser Objecte so, dass sie gerade in der Medianen eine über die ganze Oberfläche fortgesetzte, nur sehr wenig gebrochene Einheitslinie bilden (S. z. B. Castle, Fig. 62, 71) welche ohne Weiteres

schon bei schwacher Vergrößerung kenntlich ist; schneidet man also in der Mitte und senkrecht zu dieser Linie, so zerlegt man auch die Bechergastrula in 'vorn' und 'hinten.'"

It is true that the median plane is marked out by a nearly straight line, though Castle's figures to which Driesch refers show this line between endoderm and not between ectoderm cells, but any one who has studied these embryos knows how difficult it is to determine the median plane in this way, especially in living material. Even in stained and mounted preparations it would not be a sure guide, much less could it be relied upon in the study of living gastrulæ. Whether the median plane appears as a straight line or not depends entirely upon whether that plane lies directly in the line of vision, and conversely some of the transverse planes of cleavage may appear as straight lines if they lie in the line of sight. Thus Fig. 7 shows several transverse rows of ectoderm cells which in the hinder part of the embryo are curved back in the middle and forward at the sides, but if the embryo were rotated forward so that the polar body were brought to the highest point these transverse rows would appear nearly straight.

I am convinced therefore that the half gastrulæ from which Driesch obtained apparently normal larvæ were right or left halves and not anterior and posterior ones as he supposed. Whether these larvæ were really normal, *i. e.*, whether they had the organs of both the right and left sides, cannot be determined from Driesch's figures or descriptions, since he seems to have considered that the only evidence required to show that a larva is complete is that it should have a head and a tail.

The fact that Driesch always obtained partial larvæ from the anterior and posterior halves of an elongated gastrula, where the chief axis is unmistakable, requires no comment.

#### IV. OTHER EXPERIMENTAL WORK ON THE ASCIDIAN EGG.

Chabry's ('87) contribution on the normal and teratological embryology of ascidians contains not only the most careful and complete experimental work which has ever been done on the ascidian egg but it is at the same time such an excellent analytical treatment of the normal development that it deserves to rank as an embryological classic. The experimental part of his paper was based upon an unusual knowledge of the normal and patho-

logical development of this species and it was carried out with a delicacy and precision of method which has never been surpassed. Add to this the fact that the work was undertaken with clear insight into the principal problems involved and at a time when almost no other work of this sort had ever been done<sup>1</sup> and its right to rank as one of the great works in experimental embryology seems assured. Considering these facts it is surprising that this work should have received so little attention and that it should have been so widely misunderstood or discredited.

Chabry's extensive experiments deal with right and left half embryos, anterior and posterior two-quarter embryos, and various forms of three-quarter, one-quarter and two-quarter diagonal embryos, and in all of these I find that my results are in the main in accord with his. The points in which my work is more detailed than his concern the presence and distribution of the various oöplasmic substances and the more accurate study of some of the later stages, made possible by the use of fixed and stained material. That the substance of the mesodermal crescent was seen by Chabry as early as the 32-cell stage is evident from his description of the mesoderm cells, which in *Ascidia aspersa* are greenish ("verdâtre") in color and which he recognized when only three were present on each side. Neither Driesch nor Crampton speak of having observed any of these oöplasmic substances and neither of them studied the later stages by means of fixed and stained material.

### 1. *Cleavage.*

Chabry showed that in rhythm of cleavage and in the size and character of the daughter cells the isolated blastomeres of *Ascidia* behave as if they were still part of the normal egg, while he described in great detail the changes which take place in the facets between cells. Crampton's conclusions are very similar; he found that "an isolated blastomere of the *Molgula* egg segments as if still forming a corresponding part of an entire embryo. The *cleavage phenomena* are strictly *partial*, as regards the origin of cells, the inclination of cleavage planes, and especially in respect to the rhythm of segmentation." Driesch, on the other hand, found in *Phallusia* that there was no fixed relation between the

<sup>1</sup>See Roux, Ges. Abhand II, p. 958.



cleavage planes of the surviving half and the dead blastomere; that after the third cleavage the cells occupy very different positions from the normal (Tetraeder, Halbtetraeder); that divisions may be equal or unequal at the fourth cleavage, and finally that the cleavage could not be regarded as partial ("halb") nor entire ("ganz") but "regellos-solid." The evidence which Driesch brings in support of this conclusion is of little value since it is plain that he was unable to orient these cleavage forms and did not know from what part of the original egg they came nor from what pole they were viewed. My observations on the cleavage of isolated uninjured blastomeres of the egg of *Cynthia* confirm and extend the conclusions of Chabry and Crampton that the cleavage of such blastomeres is unaltered save for slight changes in the direction of some of the divisions; they are opposed to the conclusions of Driesch that the cleavage of such blastomeres is inconstant and irregular.

## 2. *Gastrula.*

Chabry figures four gastrulæ from isolated blastomeres, viz: his Figs. 108, 114, 129 and 130. O. Hertwig, who copies Fig. 129 in his book, "Die Zelle" ('98), says that it is a normal typical gastrula. Similarly Korschelt and Heider, who also copy this figure in their text-book ('02), affirm that it is a normal small gastrula. However, these authors bring no particle of evidence to the support of this bare assertion; Chabry himself nowhere says that any of the gastrulæ figured by him are normal and the figures themselves do not show that such is the case. On the other hand I can positively affirm that a normal entire gastrula is never formed from an isolated blastomere of the egg of *Cynthia*. In the absence of any evidence in favor of Hertwig's and Korschelt and Heider's interpretation and in the face of this positive evidence against it I think it may safely be assumed that Chabry's figures are not those of normal typical gastrulæ. Crampton expressly says that he did not carefully observe the process of gastrulation in the embryos derived from isolated blastomeres of the *Molgula* egg, but Driesch says that the process of gastrulation may be easily observed in *Phallusia*, that a typical ascidian gastrula is formed and that the closure of the blastopore takes place in the normal manner. "Alles sind verkleinerte Aehnlichkeitsbilder der Prozesse an normalen Eiern, welche stets verglichen wurden."

However, it is quite evident from the observations of Van Beneden and Julin, Chabry, Castle and many others that something more than a mere invagination is necessary to constitute a normal gastrula. The ascidian gastrula is bilaterally symmetrical and its anterior and posterior portions are very unlike; furthermore all the principal organs of the larva are here represented by cells of peculiar structure and localization. In order to determine whether a gastrula is normal or not all of these features have to be considered, and this Driesch has not done.

### 3. *Larva.*

It is somewhat surprising that doubt should have been expressed as to whether Chabry obtained half embryos or whole embryos of half size from one-half of the ascidian egg. He again and again declares that lesion of a single cell up to the 16-cell and probably up to the 32-cell stage always causes a "hemiterie," or monster. (Chabry, pp. 246, 249, 250, 257, 258, 261, etc.) He even enters into a calculation of the number of kinds of monsters which may be produced by injuries to the cleavage cells. He says that if at the 8-cell stage each cell is capable of four different kinds of modification (certainly less than the reality), the number of modalities of this stage is  $4^8$  (= 65536) of which only one is normal. In this way there arises that "admirable and infinite variety of monsters" to which he repeatedly refers. He says expressly, p. 289, "De là on tire aisément la conclusion (que je ne crois valable que pour l'Ascidie et les animaux, dont les blastomères sont différenciés de bonne heure), que chaque blastomère contient en puissance certaines parties dont sa mort entraîne la perte irrémédiable et que les différentes parties de l'animal sont préformées dans les différentes parties de l'oeuf." Again on p. 299 he says, "On ne saurait donc conclure avec sécurité de l'oeuf d'Ascidie à celui des autres animaux, mais, en ce qui concerne celui-ci, il est exact de dire qu'il se comporte comme s'il contenait en puissance un seul adulte déterminé et que chaque partie de l'oeuf contient une partie de cet adulte." This same conclusion is repeated again and again so that as Barfurth ('93) and Driesch ('95) have said there can be no question as to what Chabry believed that his observations and experiments proved.

The statements of Driesch and Crampton are even more positive and explicit that whole larvæ are formed from any one or more of the first four blastomeres. Driesch (p. 405 in summarizing his results uses, in part, the very words of his conclusions regarding the value of the cleavage cells in the echinoderm egg: "Aus isolirt überlebenden Blastomeren des Ascidieneies entwickelt sich nicht ein halber (resp. viertel, drei viertel) rechter oder linker (resp. vorderer oder hinterer) Embryo, sondern stets ein ganzer von halber Grosse, dem allerdings (meist) gewisse Organe von minderen Bedeutung (Otolith, ein Haftorgan fehlen." Crampton neither figures nor describes the larvæ obtained from isolated blastomeres of *Molgu'a*, but he says, p. 55, "Enough of the later development has been ascertained to prove that a larva arises which resembles the normal larva, except as regards its smaller size and certain minor defects. My results, therefore, are entirely confirmatory of those of Driesch upon *Phallusia*."

Chabry first discovered that larvæ from one of the first two blastomeres were superficially like normal larvæ in that they had head and tail, notochord, neural plate and sense spots, but he showed that they also lacked the organs distinctive of the missing side, viz: one papilla, one or more sense spots and one atrial invagination. It is surprising therefore that neither Driesch nor Crampton undertook to prove that the larvæ obtained by them from one of the first two blastomeres were really complete. One looks in vain in their papers for any evidence that the organs characteristic of that side which would have developed from the dead half (muscles, mesenchyme, papilla, atrial invagination) are present in the surviving half.

Chabry further showed that the type of embryo derived from the anterior or posterior two-quarters of the egg was very unlike that derived from the right or left two-quarters, while the one-quarter embryos were still more unlike the normal; in each of these cases he found that the development was strictly partial, only those parts arising from a blastomere which would develop from it in the normal embryo. In the face of these conclusions of Chabry's neither Driesch nor Crampton advance any evidence in favor of their claim that the anterior and posterior quadrants of the egg as well as the right or left may give rise to a larva. Chabry's figures and descriptions show plainly what my work proves that nothing even remotely resembling a normal larva is ever pro-

duced from any portion of an egg which does not include the whole of the right or left half. In my opinion Driesch and Crampton have not studied nor taken any account of anterior or posterior half embryos, but only of right or left ones. The question whether these embryos were actually complete will be considered when we come to deal with the various larval organs.

Both Driesch and Crampton make the claim that single blastomeres of the 4-cell stage of the ascidian egg may give rise to entire larvæ. This is a crucial test of their views, for while it is possible and I believe practically certain that all their "complete larvæ of half size" were derived from the right or left halves of the egg and so included portions of all the various oöplasmic substances, this explanation could not apply to their quarter embryos. Driesch figures a larva with all the principal organs (his Fig. 16), which he says is derived from one of the first four blastomeres. However, in size it is as large as any of the half larvæ which he figures, and I have no doubt that it is such.

Crampton figures correctly the early cleavages of one of the anterior quadrants and he gives two figures of quarter larvæ, probably of an advanced stage; these figures, however, show no structure whatever save that there is an outer layer around the embryo. There is absolutely no evidence that these embryos are complete. Crampton calls attention to the fact that the long axes of these quarter embryos "are approximately parallel to the principal dorso-ventral axis of the original egg," a fact which I also can confirm. (See my Figs. 66, 69, 70.) He does not, however, determine the fact, which he apparently assumes, that the long axes of these quarter embryos correspond to the long axis of a normal embryo. This is actually not true, as I have shown; the long axes of the quarter embryos are not antero-posterior in direction but dorso-ventral and there has not therefore been any shifting of the axes nor of the oöplasmic substances of these quarter embryos.

Whether a larva derived from the right or left half of the egg is complete or not can be determined only by a study of the various systems of larval organs. It is evident that parts of all organs which are normally formed along the median plane (first cleavage plane) would appear in an embryo derived from one of the first two cleavage cells, even if the development were strictly partial; the really decisive test as to whether such an embryo is complete

or not must be found in the study of those organs which do not lie along the median plane.

*a.* Neural Plate and Sense Organs.

Chabry says that he never saw a partial embryo in which the neural plate had invaginated; on the contrary the nervous system always remains spread out in the form of a layer or plate; this plate occupies the face of the embryo which is morphologically median in position (its normal location), while the sense spots consist of pigmented cells which are superficial in position and which lie near the base of the tail. This agrees very closely with my observations, though I have frequently seen the neural plate invaginate by an irregular process. The eye is said by Chabry to be formed on the right side normally, but the fact that it may appear in the left half embryo leads him to conclude that its rudiment exists in the left half of the egg also. He thinks that the otolith comes only from the right posterior cell. I have not determined the exact cell origin of the sense organs in the normal larva, but in the partial larvæ they are formed only from the anterior quadrants and from either the right or left sides. I have not been able to distinguish between the eye and the otolith in the partial embryos of *Cynthia*.

Driesch says nothing of the neural plate nor of the manner in which the nervous system is formed in his small larvæ, though he mentions the fact that "the sense vesicle with the eye and otolith are not formed in the typically clear manner characteristic of the normal development." He found the eye spot almost always present, the otolith very seldom and he concludes that it makes no difference in the presence or absence of the sense organs whether the embryo has developed from certain cells of the 4-cell stage rather than from others. Since Driesch expressly states that he never raised a quarter embryo beyond the stage of his Fig. 16, at which stage the sense organs have not appeared, and since neither his figures nor descriptions give any evidence that he has distinguished anterior or posterior quadrants from right or left ones, it would be interesting to know how he could determine that sense organs might be formed from any quadrant of the egg—a result entirely contrary to my observations.

*b.* Notochord.

Chabry supposed that the notochord arose from both the anterior and posterior quadrants of the egg. Castle ('96) held that a single pair of cells of the posterior quadrants, B<sup>8,6</sup>, "the posterior chorda fundament," were the only cells of the posterior quadrants which entered into the formation of the notochord. I am of the opinion that this cell is a mesenchyme and not a chorda cell (see Conklin, '05<sup>1</sup>), but even if it should be found to be a chorda cell it is only one cell of nine on each side of the mid line which give rise to that structure, while eight pairs of chorda cells come from the anterior quadrants. Certain it is that no trace of a notochord ever arises from the posterior cells when they are isolated, whereas chorda cells always arise from isolated anterior cells, though a notochord is rarely formed in such cases. Chabry describes (p. 294, Fig. 118) an anterior two-quarters embryo in which a naked chorda was seen in the perivitelline space outside the body of the embryo; such a case somewhat resembles the one shown in my Fig. 72. However, in every other instance which I have observed the chorda cells of an anterior embryo do not give rise to a notochord, but after escaping from the body of the embryo lie free in the perivitelline space as scattered cells. (Figs. 52, 66-70.)

But while a notochord is rarely or perhaps never formed in an anterior embryo and never in a posterior one, it is invariably found in a right or left one, and the figures of Chabry and Driesch as well as my own show that the process of formation is essentially the same as in a normal embryo. Chabry indeed believed that the notochord was primitively double and that half of it arose from each lateral half of the egg. He speaks of the fact that in *Ascidia* and *Botryllus* it is composed of a double row of cells and Crampton also refers to the fact that in the normal ascidian tadpole there are two rows of chorda cells, whereas Driesch has well said that in its fully formed condition the ascidian notochord is normally composed of a single row of cells. I find, as did Driesch, that the notochord of a lateral embryo is formed by interdigitation, just as in the normal embryo, but I also find, as opposed to Driesch that the notochord is never formed from any cells save the chorda cells which come from the posterior part of the gray crescent. Furthermore, my observations show, as did Chabry's, that the

formation of a tail is dependent upon the development of a notochord.

*c.* Muscles and Mesenchyme.

Chabry paid no particular attention to the number and location of the muscle cells in his partial larvæ, though he frequently speaks of their presence as being proved by the twitchings of the tail; these movements are less energetic than in normal larvæ and, as a consequence, partial larvæ do not escape from the egg membranes. Driesch also found that partial larvæ rarely hatch, probably because of their weak muscular movements, but he, too, paid no attention to the number and position of the muscle cells. Owing to the brilliant color of these cells in *Cynthia* they are recognizable at all stages; in the partial larvæ they are found only along one side of the notochord, where they form the characteristic three rows of cells, whereas the muscle cells of the opposite side are entirely lacking. In the oldest larvæ a few of the muscle cells extend around the end of the notochord to the side on which they were lacking. I have not been able to determine whether the number of muscle cells is actually increased during this process or merely rearranged, but I believe that the whole process consists in the moving of certain cells over to the side on which they were lacking, without any increase in their number. This is part of that process of regulation which begins with the rounding up of the surviving blastomere after the other one has been killed. In fact, this very extension of the muscle cells around the end of the notochord begins in this rounding up of the surviving blastomere and in that slight change in the direction of division which causes the median cells of the yellow crescent to lie nearer the middle of the first cleavage plane than in the normal egg. (Fig. 15.)

Chabry found (p. 308, Fig. 132) only one atrial invagination and one organ of fixation (papilla) in right or left half embryos. Driesch did not determine the number of atrial invaginations but he does call attention to the fact that but one papilla is present in embryos from isolated blastomeres. I have not observed the formation of the atrial invaginations or of the papillæ in *Cynthia*; even in the normal larvæ they are inconspicuous at the time of the metamorphosis and I have not studied them before that period. However, the areas of trunk mesenchyme in which the atrial invaginations appear, are conspicuous areas of clear, slightly

yellow, protoplasm in front of the muscle rows on each side of the tail; these areas may be recognized in the early cleavage stages and in no case are both these mesenchyme areas present in right or left half embryos. It is almost certain, therefore, that only one atrial invagination is formed in such embryos.

We find, therefore, that those parts of the larva which normally lie on the right side are missing in a left half embryo and those which normally lie on the left side are not found in a right half embryo, whereas unpaired organs which lie along the median plane are represented in both lateral half embryos. This is exactly what might be expected from a study of the organization of the egg since the substances, which give rise to median organs, are found along the median plane in both right and left blastomeres, whereas the materials which give rise to organs of the right side are found only in the right blastomere, those which give rise to organs of the left side, in corresponding positions in the left blastomere.

Neither Driesch nor Crampton attempt to show that a larva from the right half of an egg has the organs of the left side and this is the whole question at issue; if it does have these organs it is a complete embryo; if it lacks them it is a partial embryo, even if it does have a head and a tail. Chabry found that a larva from one of the first two blastomeres had a head and tail and median organs, but that it did not have the organs of the missing side and this conclusion I can entirely confirm.

All of the muscle substance (myoplasm) and most of the mesenchyme (chymoplasm) is localized in the posterior half of the egg, and corresponding to this distribution we find that an anterior half embryo entirely lacks muscles, though it may have a small amount of mesenchyme (that derived from the cell A<sup>7.6</sup>), whereas a posterior half embryo contains a large number (probably the full normal number) of muscle cells and most of the mesenchyme.

##### V. REGULATION IN THE ASCIDIAN EGG AND EMBRYO.

It is well known from the work of Loeb ('92) and L. Schultze ('99) that the brain of *Ciona* will be regenerated when extirpated in the adult animal, and that the siphons will be restored when they are cut off. Driesch ('02) has also shown that *Clavellina* has extraordinary powers of regenerating almost all lost parts.



This power of regeneration in the adult is in striking contrast with its lack in the egg and embryo and requires some explanation.

It should not be overlooked that such injuries to the egg and embryo as have been described in the preceding pages are probably more extensive and far-reaching than any which are capable of being repaired in the adult. As Chabry says the destruction of one of the first two blastomeres is the same in its effect as the destruction of the right or left half of the body of an adult. The destruction of the anterior half of the egg is similar to the total loss of the nervous system and notochord of the larva; while the death of the posterior half corresponds to the destruction of the whole of the muscular system and most of the mesenchyme of the larva, since in each case the specific substance which alone gives rise to these organs is destroyed. Therefore these injuries are probably much more extensive than any which have been practiced on the adult animal.

Furthermore, I am of the opinion that the extremely rapid development of the ascidian egg and embryo may itself act as a check on regulation. In *Cynthia* and *Ciona* the fully formed larval stage is reached in about twelve hours after the fertilization of the egg, and these larvæ usually undergo metamorphosis into the adult form within the next twelve hours. In *Molgula* the development is even more rapid. It seems to me probable that the restoration of the parts of the missing right or left half of a larva might be fully accomplished if the larval life were longer. In a right or left half larva one day old the ectoderm cells have closed over the injured side, the notochord is complete, the neural plate has invaginated, although abnormally, and the muscle cells have begun to grow over from the uninjured to the injured side. There is here evidence of considerable regulative ability and it seems to me possible that, with more time before the metamorphosis, complete rows of muscle cells might be found on both sides of the tail and that the mesenchyme cells might grow over to the side on which they are lacking and an atrial invagination appear in them.

Inasmuch as the only form of regulation shown by the ascidian egg or embryo is this overgrowth of cells from the uninjured to the injured side, it is probable that no amount of time would ever suffice to produce an entire larva from the anterior or posterior half of an egg or from a quarter or any smaller portion. As a

matter of fact there is not the slightest indication in an anterior half embryo of any attempt to restore the missing myoplasm or muscle cells, nor does a posterior half embryo show any tendency to form chorda-neuroplasm or neural plate or chorda cells. So far as observation and experiment show, each oöplasmic substance is capable of giving rise only to one particular kind of organ or tissue.

The question may be raised whether the presence of the injured blastomere within the chorion may not influence the development of the surviving cells and possibly prevent regeneration. In this and in all previous experimental work on the ascidian egg these injured cells have been left within the chorion in contact with the surviving cells and in this respect all work on these eggs has been done under similar conditions. Owing to the presence of the chorion it is practically impossible to remove the injured cells, and I am therefore unable to furnish an experimental test of the influence or lack of influence of these cells upon the surviving ones. However, there is sufficient evidence, I think, to show that it is not the presence of these cells which prevents regeneration. Contact with the injured cell might be expected to hinder or prevent the closing of the surviving half along the injured side, but it is just this form of regulation, and this only, which is manifested by these eggs. The presence of the injured cells can have nothing to do with the failure of the anterior half embryo to form a tail, or the posterior half embryo, a head; on the other hand, I have shown conclusively that the development of a tail is dependent upon the presence of a notochord, and the formation of a head upon the presence of the gastral endoderm and neural plate. The only possible influence of the injured cell upon the surviving one would be to limit the form-regulation; but as I have said this it does not do. It is inconceivable that the presence of the injured cell should prevent the myoplasm from giving rise to other organs than muscles, or the chorda-neuroplasm to other organs than chorda and neural plate.

These injured cells are rarely killed, but they remain transparent and entire, although quiescent; they do not decay and form a nidus for bacteria and I am convinced that their presence does not materially influence the development of the surviving half nor limit its powers of regulation.

## VI. GENERAL CONCLUSIONS.

The conclusions which follow from these experiments are so obvious that they need but little emphasis here. Not only is the fact established that individual blastomeres give rise only to those parts of an embryo which they would produce under normal conditions, but the cause of this is clearly indicated. The development of the ascidian egg is a mosaic work because individual blastomeres are composed of different kinds of oöplasmic material; this mosaic work is not merely a cleavage mosaic but also a mosaic of germinal substances, several of which are recognizable before cleavage begins.

I. *Organ-Forming Substances.*

I have elsewhere shown that at least five distinct kinds of oöplasm are recognizable in the egg of *Cynthia* before the first cleavage and that all of these substances are localized in their final positions as early as the close of that cleavage. In these experiments I have not been able to isolate the different oöplasmic substances in the unsegmented egg, but after the second or third cleavages several of these substances may be isolated and in such cases each substance gives rise only to a definite kind of tissue or organ, and apparently it has no power to produce any other kind. The myoplasm produces muscle cells only; the chorda-neuroplasm, only chorda and neural plate cells; the chymoplasm, only mesenchyme; the endoplasm and ectoplasm only endoderm and ectoderm, respectively. Whenever an isolated blastomere lacks any of these substances, the embryo which develops from that blastomere lacks the corresponding organs. Accordingly the potencies of individual blastomeres are dependent upon the oöplasmic substances which they contain; the prospective value of any blastomere is not primarily a function of its position, but rather of its material substance.

The reason that the anterior quadrants of the egg never produce muscle cells is evidently due to the fact that they totally lack the yellow myoplasm; the fact that the posterior quadrants never produce a neural plate or chorda, is evidently due to the complete absence of the chorda-neuroplasm in these quadrants; the cells of the ventral (animal) pole produce only ectoderm, without a trace of endoderm or mesoderm,—evidently because these cells are composed almost entirely of clear ectoplasm.

*Experiment confirms, therefore, what observation of the normal development plainly indicates that these strikingly different oöplasmic substances are not totipotent, but that as early as the close of the first cleavage and probably much earlier, they are differentiated for particular ends, and that if they develop at all they give rise to organs of a particular kind. These materials are, therefore, "organ-forming substances" and the areas of the egg in which they are localized are "organ-forming regions."*

I need not here point out the similarity between this conclusion and the well-known theories of Sachs and His, nor the differences between my results and the commonly accepted view that the egg is composed of "simple undifferentiated protoplasm" or that "cleavage is a mere sundering of homogeneous materials capable of any fate," or that "the prospective value of a blastomere is a function of its position." Whatever may be true of other animals these things are certainly not true of ascidians.

While there are few, if any, other cases known in which the differentiations of the oöplasm are so striking or so numerous as in the egg of *Cynthia* there can be no doubt that organ-forming substances are present in the eggs of many animals. In particular the works of Fischel ('97, '98, '03) on the *Ctenophore*, of Boveri ('01) on *Strongylocentrotus*; of Wilson ('04) on *Dentalium* and *Patella* and of Conklin ('03) on *Physa*, *Planorbis* and *Limnæa* have shown that distinct kinds of protoplasm are present in these eggs which are destined in the course of development to give rise to particular germ layers or organs. In the light of these discoveries it can scarcely be doubted that the general cause of mosaic development is to be found in the presence in the egg or blastomeres of distinct kinds of protoplasm, or of organ-forming substances.

## 2. *Localization of Oöplasmic Substances.*

The three principal substances in the egg of *Cynthia*, viz: the clear, the yellow and the gray, are already present and localized in the oöcyte before it escapes from the ovary. The yellow (mesoplasm) forms a peripheral layer around the entire egg; the clear (ectoplasm) is the clear achromatic substance within the germinal vesicle; the gray (endoplasm) constitutes most of the

remainder of the egg.<sup>1</sup> For the sake of brevity this earliest form of localization may be described as concentric or spherical, although the germinal vesicle does not lie exactly in the center of the egg but is slightly eccentric toward one pole.

During maturation and fertilization this concentric localization gives place to a polar or radial form. Immediately after the entrance of the spermatozoon into the egg the peripheral layer of yellow mesoplasm flows rapidly to the lower pole where it collects in the form of a cap; the clear ectoplasm which escapes from the germinal vesicle at first lies at the animal pole where it surrounds the maturation spindles but after the entrance of the spermatozoon it also flows to the lower pole where it collects into a layer or stratum just above the mesoplasm; the gray endoplasm after these movements occupies almost all of the upper half of the egg. The egg at this stage appears to be radially symmetrical, the three principal substances being arranged in strata at right angles to the egg axis.

Soon after the entrance of the spermatozoon this radial form of localization gives place to a bilateral one; the sperm nucleus and aster move up to the equator of the egg along one meridian which further development shows to be the median plane on the posterior side; the clear and yellow substances also move to the posterior pole along with the sperm nucleus and the yellow substance here forms a crescent around the posterior side of the egg, just below the equator. At this stage the egg is bilaterally symmetrical, there being but one plane which will divide equally all of the oöplasmic substances.

Finally during the first cleavage this early bilateral localization is changed into the definitive localization which is characteristic of all stages up to the late gastrula. The yellow crescent remains in the position which it occupied before the first cleavage and here gives rise to muscle and mesenchyme cells; the clear protoplasm comes to occupy most of the ventral hemisphere and gives rise to ectoderm; the gray substance occupies the dorsal hemisphere in

---

<sup>1</sup>Although I have not been able to isolate these various oöplasmic substances before cleavage begins and, therefore, can bring no experimental evidence to prove that they are organ-forming substances at this early stage, it nevertheless seems probable that materials which are identical in color and texture with the organ-forming substances of later stages, to which they directly give rise, are also similar in potency. There is no apparent reason for believing that these strikingly different kinds of oöplasm of the ovarian egg are any less distinct or more nearly totipotent than during the cleavage stages.

front of the yellow crescent and its anterior portion becomes the gray crescent of chorda-neuroplasm, while its posterior portion is the deep gray endoplasm which gives rise to the gastral endoderm.

The form of localization of these substances, therefore, undergoes marked changes during the fertilization and first cleavage; it is concentric in the oöcyte, polar or radial immediately after the entrance of the sperm, bilateral just before the first cleavage, and definitive at the close of the first cleavage.

I have elsewhere ('05<sup>1</sup>) shown reason for believing that even in the stage of radial localization in the egg of *Cynthia* there is probably some structural peculiarity of the egg which determines that the path of the sperm shall lie in one meridian rather than in another and therefore that the median plane of the embryo and its posterior pole are not determined by the chance movements of the sperm within the egg. Similarly the basis for polar or radial localization is present in the ovarian egg in the slight eccentricity of the germinal vesicle toward the animal pole, though the oöplasmic substances are largely localized in concentric form at this stage. I am unable to determine whether any structural basis for bilateral localization exists in the ovarian eggs of ascidians, but inasmuch as the localization invariably becomes bilateral at a later stage it seems necessary to suppose that there is some such intrinsic determinative factor.

In almost every group of animals the chief axis of the egg is already marked out in the oöcyte, the pole toward which the germinal vesicle is eccentric becoming later the animal pole of the egg and the ectodermal pole of the embryo. Despite this eccentricity of the germinal vesicle the localization of oöplasmic substances in the oöcyte of ctenophores, nemertines, echinoderms and ascidians is chiefly concentric, the polar localization of these substances first appearing during the maturation and fertilization. On the other hand Wilson ('04) has found a markedly polar localization of the oöplasm in the oöcyte of *Dentalium*; while it is probable that in the oöcytes of insects and cephalopods the localization is bilateral in form.

Boveri ('01) found that distortion of the egg of *Strongylocentrotus* after the formation of the equatorial zone produced no change in the polar stratification of the egg nor in the potencies of its different substances. Wilson ('03), Yatsu ('04) and Zeleny ('04) have discovered that fragments from any part of the egg of

Cerebratulus before maturation may give rise to entire larvæ; whereas this is not usually the case after maturation and fertilization, the potencies of the substances at the animal and vegetal poles being different. It is evident that during the concentric stage of localization section of an egg in any plane would leave samples of all the oöplasmic substances in each piece; in the stage of polar-radial localization any section of the egg parallel with the egg axis would leave samples of all the oöplasmic substances in each piece; in the bilateral stage, only the right or left halves would contain parts of all the substances. Probably one important reason why parts of eggs may give rise to whole embryos in some cases and not in others may be found in the fact that at the time of the experiment the form of localization may have been concentric in some cases, radial in others and bilateral in still others. (See Boveri, '01; Wilson, '04<sup>1</sup>.)

### 3. *Cleavage and Localization.*

In previous publications ('05<sup>1</sup>, '05<sup>2</sup>) I have pointed out the fact that localization precedes cleavage in the ascidian egg and that the localization pattern does not closely coincide with the cleavage pattern. On the other hand there is normally a constant relation between particular cleavage planes and the various oöplasmic substances. The first cleavage always lies in the median plane and bisects all the oöplasmic substances; the second is transverse to the median plane and separates the yellow crescent from the gray one; the third cleavage is at right angles to the two preceding ones and separates the clear ectoplasm of the ventral hemisphere from the different substances of the dorsal hemisphere. Probably in no other animal is the cleavage so constant and so perfectly bilateral as in the ascidians and yet even here the position and direction of the cleavage planes is less constant than the form of localization.

Among annelids and mollusks, as is well known, the cleavage is typically spiral and in many cases it is radially symmetrical. This radial symmetry of cleavage does not indicate, however, that the localization of oöplasmic substances is also radially symmetrical, for in some cases this localization is known to be bilateral and this is probably true in all cases. (See Conklin, '05<sup>1</sup>, pp. 90-92.)

The relation of the cleavage planes to this bilateral organization

is very different in cases of spiral and of bilateral cleavage, and consequently the results of killing any one or more of the first four blastomeres may vary in different cases; in general there is less likelihood of obtaining an entire embryo from an isolated blastomere of spiral cleavage than from one of the first two blastomeres in bilateral cleavage.

In other cases the cleavage planes bear no constant relation to the planes of localization. Thus in the frog's egg the first cleavage may lie in the median plane or at varying angles to this plane and Brachet ('04) has recently shown that the character of an embryo derived from one of the first two blastomeres depends entirely upon the relation between the first cleavage plane and the median plane of organization.

It is probable that the bilaterality of organization is no more perfect in ascidians than in annelids, mollusks or amphibians, but the bilaterality of cleavage is much more perfect. Accordingly, each of the first two blastomeres of the ascidian egg always contains half of every oöplasmic substance, in the frog's egg it may or may not contain half of these substances, in the annelid or mollusk it never does.

I agree therefore with Brachet ('04) and Wilson ('04<sup>1</sup>, '04<sup>2</sup>) that the varying results of experiments on the potencies of blastomeres are due in part to the varying relations of cleavage to localization, and in part also to the different types of localization (concentric, radial, bilateral) in different eggs.

#### 4. *Determinate and Indeterminate Cleavage and Development.*

In a great many animals belonging to phyla as widely separate as Ctenophora, Polyclada, Nemertinea, Nematoda, Rotifera, Annelida, Mollusca, Arthropoda and Tunicata the cleavage of the egg is constant in form and differential in character and under normal conditions, definite cleavage cells always give rise to definite structures of the embryo or larva. For this type of cleavage I proposed several years ago ('97, '98) the designation "determinate." In a few animals the cleavage is known to be extremely irregular, as in *Pennaria* (Hargitt, '04), *Renilla* (Wilson, '84), and probably also in planarians (Hallez, '87; Stevens, '04), while in other cases it is unknown whether the cleavage is normally constant and differential or not (Echinoderms); in still other cases



the planes of cleavage bear no constant relation to the planes of localization, as in the eggs of some of the vertebrates (frog, fish). For all such cleavages I proposed the name "indeterminate," but at the same time I was careful to state that this was "to be understood as applying only to the cleavage, for in its main features and results the development of all animals is determinate; that is, predictable. Even in cnidaria, echinoderms and vertebrates there appears successively a blastula, gastrula, larva, and adult of determinate form and character" ('98, p. 21).

But while the cleavage is indeterminate in some cases there is reason to suppose that there is a definite organization of the egg in all animals—in short that the organization of the individual is determinate at all stages from the egg to the adult. Even in such an egg as that of *Pennaria* it is certain that there must be determinative factors somewhere, if not in the cytoplasm then in the nucleus, which determine that the egg shall develop into a *Pennaria* rather than into some other animal; and it is further evident that these determinative factors must be present in the cytoplasm at a relatively early stage, if not at the very beginning of development.

In the echinoderm egg, which was at one time supposed to be homogeneous or isotropic, Boveri ('01) has shown that a polar-radial localization of at least three distinct morphogenetic substances takes place immediately after maturation, and in this case, as in the ascidians it is probable that there is an earlier concentric localization of these substances in the oöcyte. Since these three substances are localized in zones or strata, one above the other, around the chief axis of the egg, they are all present in each of the first four blastomeres of the egg, each of which may give rise to an entire embryo; but when they are isolated each is found to be strictly limited in its potentialities.

While therefore there are several groups of animals in which the cleavage is indeterminate there are few or none in which the oöplasm is isotropic; on the contrary in almost every phylum the eggs and blastomeres show differentiations and localizations of the oöplasm which are of morphogenetic value. "Everywhere," as Fischel ('03) has well said, "the fundamental principle of normal development is a mosaic work." But while Fischel supposes that "only the materials for the primitive organs of the embryo are preformed in the egg cell and that the material substratum for the differentiation of the special organs is probably first formed during

the later stages," I find that in the ascidian egg all the principal organs of the larva are represented by distinct organ-forming substances which are localized in their definitive positions and proportions as early as the close of the first cleavage.

There is a world-wide difference between such results as these and those which were reached by Driesch and some of the earlier workers in this field. Wilson ('04) has recently expressed the opinion that "had the experimental analysis of cleavage been first undertaken in the case of such a determinate type as that of the gasteropod or annelid and had Roux not handicapped his theory with a purely speculative hypothesis of differentiation, which proved to be untenable, the whole discussion would have taken a different course; and I believe it would from the first have been recognized that the mosaic principle holds true in greater or less degree for every type of development, not excepting the most 'indeterminate' forms of cleavage." Considering the fact that such highly determinate forms as the ascidian and the ctenophore were studied in some of the earliest experiments on the potency of cleavage cells, I am of the opinion that the course which this discussion took was not primarily due to the fact that work began on relatively indeterminate forms. On the other hand I am convinced that the whole trend of opinion on the organization of the egg and on the potency of cleavage cells would have been different if those who did this work had been more familiar with the normal development of the forms studied, and in their zeal for the experimental method had not discarded the old and approved method of observation. It has taken such careful observers of normal processes as Boveri and Wilson to apply most successfully the experimental method to the problem of the organization of the egg, and the results of such work constitute a well-deserved tribute to the permanent value of the work of Roux.

#### SUMMARY.

##### I. *Normal Development.*

1. In the ovarian egg of *Cynthia* (*Styela*) *partita* there are three strikingly different kinds of oöplasm, viz: a superficial yellow layer, a central gray area, and a large transparent germinal vesicle. At this stage the localization of these substances is approximately concentric.

2. During maturation and fertilization the yellow substance flows rapidly to the vegetal pole where it forms a superficial layer or cap; the clear substance escapes from the germinal vesicle and flows toward the vegetal pole where it forms a stratum above the yellow cap; the gray substance occupies the animal half of the egg. The localization at this stage is polar-radial.

3. The sperm nucleus which lies in the center of the yellow cap moves to the posterior pole of the egg and the yellow and clear substances move with it. The yellow material here forms a crescent which lies with its center at the posterior pole and its arms extending forward on each side about halfway around the egg; the clear substance forms a band just above and internal to the crescent; the gray substance occupies the remainder of the egg. At this stage the localization is bilateral.

4. The first cleavage furrow appears in the plane of bilateral symmetry and divides each of the oöplasmic substances equally. At the close of this cleavage the clear substance occupies the animal (ventral) half of the egg; the gray substance lies at the middle of the vegetal (dorsal) pole while around the posterior border of the dorsal hemisphere is the yellow crescent and around its anterior border is a light gray crescent. This is the definitive localization of these substances, and in these positions the clear material gives rise to ectoderm, the gray to endoderm, the yellow crescent to muscles and mesenchyme, and the gray crescent to chorda and neural plate.

5. The second cleavage is transverse to the antero-posterior axis and separates the gray crescent from the yellow; the third cleavage separates the clear protoplasm of the ventral hemisphere from the various substances of the dorsal hemisphere.

## II. *Experiments.*

6. Individual blastomeres were injured by spurting or shaking the eggs in the 2, 4, 8, or 16-cell stages. The surviving blastomeres were then studied both in the living condition and after being stained and mounted.

7. *Cleavage.* Isolated blastomeres always segment as if they still formed part of the whole, except that the direction of some of the cleavages is slightly altered so that the resulting cell mass is more nearly spherical than in the normal egg. These alterations

in the direction of cleavage and the consequent closing of the injured side are more apparent in isolated blastomeres of the 2-cell stage than in those of later stages.

8. *Gastrulation.* In right or left or anterior halves, gastrulation usually proceeds as if the fragment still formed part of the whole; even though the gastrula may be rounded in form the location of the different substances shows that it is strictly partial. Not infrequently isolated blastomeres give rise to exogastrulæ, which ultimately right themselves. In posterior halves and in quarter embryos, gastrulation does not at all resemble the normal process, either in methods or results.

9. *Right or Left Half Embryos.* A lateral half embryo is usually closed along the injured side; it has a head and a tail; a typical notochord, which is formed only from the chorda cells of the surviving side, and which is therefore composed of half the normal number of cells; an atypical neural plate and sense vesicle, formed only from the typical neural plate cells of the surviving side; a typical mesenchyme area in which the atrial invagination of one side is formed and three typical rows of muscle cells on one side of the notochord, but none along the injured side. In the latest stages to which these lateral embryos were reared (corresponding to the period of metamorphosis in normal larvæ) the muscle cells have begun to grow around the hinder end of the notochord to the side on which they were lacking; but in no case are the three rows of the normal embryo present on this side. Probably only one atrial invagination and one papilla are ever formed in these lateral embryos. These are therefore half embryos in which some cells have grown over from the uninjured to the injured side, but in which absolutely no change has taken place in the potency of the individual cells or of the different oöplasmic substances.

10. *Anterior Half Embryos.* Embryos derived from the two anterior quadrants of the egg have no trace of muscle cells nor of muscle substance; although the normal number of chorda cells are present they rarely if ever form a notochord but usually escape from the body of the embryo and lie scattered in the perivitelline space; the neural plate cells are present in normal number and position but the plate rarely, if ever, invaginates to form a sense vesicle; in late stages sense spots are formed from certain cells of the neural plate; cells of the gastral endoderm and general ecto-

derm are frequently present in their normal positions and numbers. A tail is never formed in these anterior embryos and they bear no resemblance whatever to a normal larva.

11. *Posterior Half Embryos.* Embryos derived from the two posterior quadrants have no trace of notochord or of chorda cells, neural plate, sense vesicle, sense spots, or gastral endoderm; they contain a mass of muscle and mesenchyme cells and a double row of caudal endoderm cells, as in the normal embryo. There is no indication of a tail or head, the embryo remaining rounded in form as long as it lives.

12. *Three-Quarter Embryos.* Embryos derived from three of the first four blastomeres are more nearly perfect than are half embryos, but they always show defects corresponding to the missing blastomere. If an anterior blastomere is killed, the neural plate and sense vesicle of the resulting larva are atypical and the notochord lacks the normal number of cells; if a posterior cell is killed, the muscle and mesenchyme cells are lacking along one side of the tail.

13. *One-Quarter Embryos; Two-Quarter Diagonal Embryos.* Embryos derived from any one quadrant or from two diagonal quadrants of the egg are always very defective. They never have a notochord, though if they come from anterior quadrants they may give rise to scattered chorda cells in the perivitelline space; there is never a sense vesicle, though if they are from an anterior quadrant a neural plate and sense spots are present. The posterior quadrants always contain muscle, mesenchyme and caudal endoderm cells, but never a trace of notochord, neural plate nor sense spots. The embryos are always rounded, there being no distinction of head and tail, and in no respect do they resemble normal larvæ.

14. *Eighth and Sixteenth Embryos.* When blastomeres are injured in the 8-cell or 16-cell stages a great variety of abnormal forms are produced. Ventral blastomeres give rise only to rounded masses of ectoderm cells in which there is no trace of endoderm or mesoderm; posterior dorsal cells give rise only to muscle, mesenchyme, and caudal endoderm; anterior dorsal cells to neural plate, chorda, and gastral endoderm.

15. *Anterior and Posterior Half Gastrulæ.* When cup-shaped gastrulæ of the stage shown in Fig. 8 are cut in two transversely so as to leave all of the yellow cells in one half and all of the chorda

and neural plate cells in the other a notochord, sense vesicle, or tail is never formed and nothing resembling a normal larva develops from either half. The anterior half never contains muscle cells; the posterior half contains many muscle and mesenchyme cells, but evidently no chorda or neural plate cells.

### III. *Conclusions.*

16. My results confirm and extend those of Chabry, but they are fundamentally unlike those of Driesch; I agree with the work of Crampton as to the cleavage of isolated blastomeres but cannot agree with him that whole embryos or larvæ are ever formed from isolated blastomeres of the ascidian egg.

17. Regulation in the ascidian egg and embryo is limited to the closing of the embryo and the consequent extension of certain cells from the uninjured to the injured side; and also to the formation of a typical notochord and an atypical sense vesicle in right or left half embryos. One oöplasmic substance never gives rise to another nor does a given type of cell ever produce cells of another type or organs of a different kind than those which would arise from it in a normal embryo. The fact that the power of regulation is apparently greater in the adult ascidian than in the egg or embryo may be deceptive; the injury to the egg which wipes out completely certain oöplasmic substances may be really greater than any which may be repaired in the adult. Furthermore it is possible that the very rapid development of ascidians may act as a check on regulation.

18. These results prove that at least five of the substances which are present in the egg at the close of the first cleavage, viz: ectoplasm, endoplasm, myoplasm, chymoplasm, and chorda-neuroplasm, are organ-forming substances. They develop, if they develop at all, into the organs which they would normally produce; and conversely, embryos which lack these substances, lack also the organs which would form from them. Although I have been unable to test the potencies of these substances before cleavage begins, there seems to be no reason for supposing that they are ever totipotent. Three of these substances are clearly distinguishable in the ovarian egg and I do not doubt that even at this stage they are differentiated for particular ends.

19. A possible explanation of the fact that all the fragments of an immature egg may give rise to entire larvæ, whereas the proportion which gives rise to larvæ steadily decreases after maturation and fertilization, may be found in the fact that before maturation the localization of oöplasmic substances is usually concentric, after maturation and fertilization, polar-radial; while just before or shortly after the first cleavage the localization may become bilateral. Also the fact that isolated blastomeres may give rise to whole embryos in some animals and to partial ones in others may be due to the varying relations of cleavage planes to localization planes. If at the close of the second cleavage the localization is still radially symmetrical, each of the first four blastomeres would probably be capable of giving rise to an entire larva; if the first cleavage invariably lies in the plane of bilateral symmetry, as in ascidians, each of the first two blastomeres might be capable of giving rise to an entire larva (though my work shows that this would not necessarily happen); if the cleavage planes do not coincide with the planes of localization, as in mollusks and annelids, isolated blastomeres would not give rise to entire larvæ. (See Wilson, '04<sup>1</sup>, '04<sup>2</sup>.)

20. The development of ascidians is a mosaic work because there are definitely localized organ-forming substances in the egg; in fact the mosaic is one of organ-forming substances rather than of cleavage cells. The study of ctenophores, nemertines, annelids, mollusks, ascidians and amphibians (the frog) shows that the same is probably true of all these forms and it suggests that the mosaic principle may apply to all animals. (*cf.* Fischel, Wilson.)

## LITERATURE CITED.

- BARFURTH, D., '93.—Halbbildung oder Ganzbildung von halber Grosse? *Anat. Anz.*, viii.
- BENEDEN, VAN ET JULIN, '84.—La segmentation chez les ascidiens dans ses rapports avec l'organization de la larve. *Arch. de Biol.*, v.
- BOVERI, TH., '01.—Ueber die Polarität des Seeigeleies. *Verh. Phys. Med. Ges., Würzburg*, xxxiv.
- '01.—Die Polarität von Ovocyte, Ei und Larve des *Strongylocentrotus lividus*. *Zool. Jahrb.*, xiv.
- BRACHET, A., '04.—Recherches expérimentales sur l'oeuf de *Rana fusca*. *Arch. de Biol.*, xxi.

- CASTLE, W. E., '96.—The Early Embryology of *Ciona intestinalis*, Flemming L. Bull. Mus. Comp. Zool., xxvii.
- CHABRY, L., '87.—Contribution à l'embryologie normale et teratologique des Ascidies simples. Journ. Anat. et Physiol., xxiii.
- CONKLIN, E. G., '97.—The Embryology of *Crepidula*. Jour. Morph., xiii.  
'98.—Cleavage and Differentiation. Woods Hole Biol. Lect.  
'03.—The Earliest Differentiations of the Egg. Science, xvii.  
'05<sup>1</sup>.—The Organization and Cell-Lineage of the Ascidian Egg. Jour. Acad. Nat. Sci., Philad., xiii.  
'05<sup>2</sup>.—Organ-Forming Substances in the Eggs of Ascidiens. Biol. Bull., viii.
- CRAMPTON, H. E., '97.—The Ascidian Half-Embryo. Ann. New York Aca. Sci., x.
- DRIESCH, H., '95.—Von der Entwicklung einzelner Ascidiensblastomeren. Arch. Entw. Mech., i.  
'02.—Studien über das Regulationsvermögen der Organismen. 6 Die Restitutionen der *Clavellina lepadiformis*. Arch. Entw. Mech., xiv.  
'03.—Ueber Aenderung der Regulationsfähigkeiten im Verlauf der Entwicklung bei Ascidiens. Arch. Entw. Mech., xvii.
- FISCHEL, A., '97, '98.—Experimentelle Untersuchungen am Ctenophorenei. I and II Arch. Entw. Mech., vi, vii.  
'03.—Entwicklung und Organ-Differenzirung. Arch. Entw. Mech., xv.
- HALLEZ, P., '87.—Embryogénie des Dendrocoeles d'eau douce. Paris.
- HARGITT, C. W., '04.—The Early Development of *Pennaria tiarella*. McCr. Arch. Entw. Mech., xviii.
- HERTWIG, O., '92.—Urmund und Spina Bifida. Arch. Mik. Anat., xxxix.  
'98.—Die Zelle, II. Jena.
- KORSCHULT UND HEIDER, '02.—Lehrbuch der vergleichenden Entwicklungsgeschichte. Allgemeine Theil. Jena.
- LOEB, J., '92.—Untersuchungen zur Physiologischen Morphologie der Thiere, vi and vii.
- ROUX, W., '95.—Gesammelte Abhandlungen über Entwicklungsmechanik der Organismen. Bd. II, Leipzig.  
'92.—Ueber das Entwicklungsmechanische Vermögen jeder der beiden ersten Furchungszellen des Eies. Verh. d. Anat. Ges. zu Wien.  
'03.—Ueber die Ursachen der Bestimmung der Hauptrichtungen des Embryo im Froschei. Anat. Anz., xxiii.



- SCHULTZE, L. S., '99.—Die Regeneration des Ganglions von *Ciona intestinalis* L. und über das Verhältnis der Regeneration und Knospung zur Keimblätterlehre. *Jena. Zeit.*, xxxiii.
- STEVENS, N. M., '04.—On the Germ Cells and the Embryology of *Planaria Simplicissima*. *Proc. Acad. Nat. Sci., Philad.*
- WEISMANN, A., '92.—Das Keimplasma. *Jena.*
- WILSON, E. B., '84.—The Development of *Renilla*. *Philos. Trans.*, clxxiv.
- '03.—Experiments on Cleavage and Localization in the Nemertine Egg. *Arch. Entw. Mech.*, xvi.
- '04<sup>1</sup>.—Experimental Studies on Germinal Localization, I and II. *Jour. Exp. Zoöl.*, i.
- '04<sup>2</sup>.—Mosaic Development in the Annelid Egg. *Science*, xx.
- YATSU, N., '04.—Experiments on the Development of Egg Fragments in *Cerebratulus*. *Biol. Bull.*, vi.
- ZELNY, C., '04.—Experiments on the Localization of Developmental Factors in the Nemertine Egg. *Jour. Exp. Zoöl.*, i.



## DIMORPHISM AND REGENERATION IN METRIDIDIUM.

BY

C. W. HAHN.

WITH 2 FIGURES.

The experiments on which this paper is based were begun at Harvard University in the winter of 1901-02 and continued at the United States Fish Commission Laboratory at Woods Hole in the summers of 1902 and 1903.

To Prof. E. L. Mark, Director of the Harvard Zoölogical Laboratory, and Drs. H. M. Smith and Francis B. Sumner, directors in successive years of the Fish Commission Laboratory, I wish to express thanks for the accommodations kindly provided for the work.

At the suggestion of Dr. W. E. Castle, to whom I am deeply indebted for guidance and help throughout this investigation, I undertook to discover if the dimorphism which occurs in *Metridium marginatum* Milne-Edwards, is perpetuated in accordance with some hereditary law, perhaps related to the law of Mendel. So far at least as concerns asexual reproduction, it soon became evident that this is not the case. Further studies have shown that the dimorphism is due to a peculiar method of development in asexual reproduction.

The dimorphism of actinians was noticed and described more or less completely by Thorell ('59), Dixon ('88), McMurrich ('89), and Carlgren ('93), but the first full discussion of it was made by Parker ('97), and the only extensive experimental study thus far made with a view to discovering the exact nature of the anomaly is that of Carlgren ('04).

The dimorphic condition referred to is this: The polyps of a given species may have either one or two (rarely three) siphonoglyphs. With each siphonoglyph, as shown for *Metridium* by Parker ('97), there is invariably associated a pair of directive mesenteries.

The siphonoglyph is a groove in the œsophagus, covered with cilia, which tend to set up a current of water into the polyp. The relative abundance of monoglyphic, diglyphic and triglyphic Metridia, as indicated by observations of Torrey ('98), Parker ('99), and myself, is shown in Table I. Monoglyphic polyps, it will be observed, predominate in all localities examined, though the proportion varies within wide limits. The large and small

TABLE I.

Locality.	Total No. Counted.	Number Diglyphic.	Number Monoglyphic.	Per cent Monoglyphic.
Newport, R. I. (Parker) .....	131	53	77	59
Oakland, Cal. (Torrey).....	200	43	157	78.5
Salem, Mass.....	465	57	399	85.8
Lynn, Mass.....	670	53	611	92.6
Woods Hole, Mass.....	123	15	108	87.8

polyps from the same locality occur with about the same proportion of monoglyphic to diglyphic forms. There is no discoverable correlation with any variation in color or in structure, save the constantly associated pair of directive mesenteries and perhaps certain irregularities of the non-directive mesenteries. These structures have been investigated by Parker ('97, '99). He finds the diglyphic character to be associated more often with regularity in the number and arrangement of the non-directive mesenteries. But the variations in the mesenteries are not conformable to any known laws and cannot be regarded as of specific importance.

My first experiments were directed toward discovering whether monoglyphic and diglyphic polyps produce, in asexual reproduction, each its own sort only. The result obtained gave an emphatic negative to this hypothesis. Each sort was found to produce, by asexual methods, both monoglyphic and diglyphic polyps, monoglyphic individuals predominating among the young in both cases.

Two methods of inducing multiplication were employed. The anemones were, in some cases, divided into halves by a vertical cut, so as to produce artificially specimens equivalent to those

supposedly produced by fission in nature. The greatest success, however, was attained when fragments were cut from the basal portion of a polyp, as in the natural process of basal fragmentation. In either case the number of siphonoglyphs in the parent polyp was determined, so that the fragments from monoglyphic and diglyphic parents might be kept separate.

Diglyphic and monoglyphic parent polyps could be distinguished either by inspection externally, when they were fully expanded, or by cutting the contracted polyp across after removing fragments from its base. The fully regenerated young were stupefied by means of magnesium sulphate and fixed in chromic acid (1 per cent) then imbedded in paraffin and sectioned. Staining the sections with hæmatoxylin and eosin made it possible, with a low power of the microscope, to decide the various questions on which the interpretation of a polyp's structure depends.

Fragments cut from monoglyphic polyps produced twenty-eight monoglyphic and five diglyphic individuals. (See Table II.) Three of the diglyphic polyps were *simple*, *i. e.*, having a single œsophagus to which the two pairs of directive mesenteries were attached; two were *double*, *i. e.*, having a divided œsophagus, each branch of which was connected with a different pair of directive mesenteries, as if a portion of œsophagus had been produced in connection with each pair of directives, but the two portions had failed to unite.

There were also twelve polyps regenerated from fragments cut from monoglyphic parents, which up to the time when they were examined had developed no mesenteries which could be recognized as directives. It is probable, however, for reasons which will presently appear, that most, if not all, of these would have become unmistakably monoglyphic polyps had they been given a longer time for regeneration.

Fragments cut from diglyphic polyps produced in all thirty-six monoglyphic and ten diglyphic polyps, all simple, as well as two polyps whose character was indeterminable.

These experiments show conclusively that each sort of polyp can produce the other by asexual methods; but, it will be observed, the diglyphic parents produced a somewhat greater proportion of diglyphic young, and the question at once arose whether this might not be due to an hereditary influence. A more careful study, however, of the regenerated polyps showed that such was

not the case. It was found that in the monoglyphic polyps the directive mesenteries arose regularly from the *new* or regenerated portion of the body-wall, and that in the diglyphic polyps, likewise, *one* of the two pairs of directives arose in this same position, but the other arose from the old or parental tissue. This observation at once suggested a different explanation of the dimorphism, *viz.*: that it was due not to the monoglyphic or diglyphic nature of the parent polyp, but to the character of the fragment from which regeneration took place. If this fragment contained a pair of directive mesenteries the polyp produced would be diglyphic, since it would retain the pair of directives derived from the parent and gain a second pair through regeneration. If, on the other hand, the parent fragment contained no directive mesenteries, then the regenerated polyp would be monoglyphic, containing only the pair of directives produced in the new tissue.

To test this hypothesis a more detailed examination of the polyps was made, the monoglyphic polyps of different parentage being compared with each other, and, likewise, the two lots of diglyphic polyps with each other.

In determining which is the regenerated portion of a polyp no single character can be relied upon. Usually considerable familiarity is necessary to enable one to distinguish regenerated from parent tissue. The latter, as seen in cross-section, is usually characterized by deep folds of the ectoderm into which small V-shaped points of the mesogloea extend. (Figs. 1 and 2.) The external surface in this side is more regular and evenly curved; the mesenteries are quite regular, especially is this true of the secondaries and tertiaries in relation to the primaries. The primaries arising from the old portion of the body-wall are longer than those arising from the regenerated part. The mesogloea on the regenerated side is not of uniform thickness or contour and does not conform as regularly with the folds of the ectoderm, when such exist. Regenerated directives and old directives usually differ in length and thickness when viewed in cross-sections, the former usually being short and thick. (Figs. 1 and 2.) These conditions, however, vary greatly, but when the evidence from one criterion is uncertain that furnished by other criteria is usually conclusive.

The results of the detailed examination made are incorporated in Table II. From this it will be seen that the monoglyphic

polyps derived from monoglyphic parents had the directives developed in new tissue in all except one of twenty-six cases, in which the limits of old and new tissue could be recognized. In that one case the directives clearly were attached to the old or

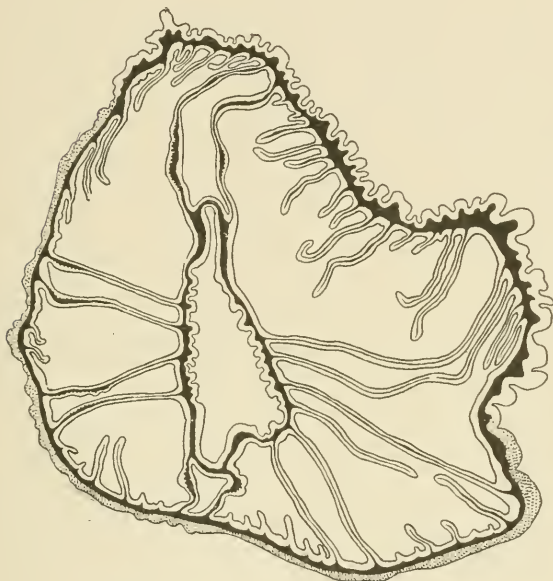

FIG. 1.



FIG. 2.

FIG. 1. Cross section of a diglyphic polyp produced by a fragment cut from the foot-disc of a diglyphic parent in such a way as to include a pair of directive mesenteries. The parental directives lie in the upper half of the figure, the regenerated directives in the lower half. The ectoderm is stippled in the regenerated portion of the body-wall. (From a camera lucida drawing, histological details being omitted.)

FIG. 2. Cross section of a monoglyphic polyp produced by a fragment cut from the foot-disc of a diglyphic polyp so as not to include directive mesenteries. The regenerated portion of the body-wall is indicated, as in Fig. 1, by stippling of the ectoderm. The single short pair of directive mesenteries is attached to this portion of the body-wall. (From a camera lucida drawing, histological details being omitted.)

parental part of the body-wall. It would seem, accordingly, that in this exceptional case no directives had been produced in the new tissue. Had this taken place the polyp would have been diglyphic, with the directives arranged exactly as in the twelve

diglyphic polyps mentioned in the fifth column of Table II. This peculiar monoglyphic polyp may be considered the result

TABLE II.

Parents.	Young.	With Directives in New Tissue.	With Directives in Old Tissue.	With One Pair of Directives in New Tissue, One in Old.	With Both Pairs of Directives in New Tissue.	Limits of Old and New Tissue Uncertain.	Totals.
M.....	M	25	1	—	—	2	28
	D	—	—	3	2 (double)	—	5
D.....	M	24	1	—	—	11	36
	D	—	—	9	1?	—	10

Character of polyps produced by basal fragments cut from monoglyphic and from diglyphic parents respectively, the relation of the cut to the parental directives being unknown in a majority of cases. M = monoglyphic; D = diglyphic.

of the union of the cut edges of the parental fragment without regeneration of a directive system. Such a result occurs not infrequently in the case of fragments containing only non-directive mesenteries, as well as of those, like this one, which contain a pair of directives. In the former case wholly aglyphic polyps are produced. Three such were observed in these experiments. Carlgren ('04) has shown, in the case of *Sagartia*, that such a result is obtained most often when the parental fragments are of relatively large size. It is probable that the same is true in *Metridium*, though precise observations on this point are wanting.

The monoglyphic polyps of diglyphic parentage, like those of monoglyphic parentage, had the directive mesenteries in all cases except one (out of a total of twenty-five) in the regenerated area. In that one case the single pair of directives was clearly received directly from the parent polyp and no new directives had been regenerated. Likewise in the case of the diglyphic polyps no difference was recognizable between those of monoglyphic parentage and those of diglyphic parentage. In all cases except possibly one there was a pair of directives in the old tissue, and one in the new. There were three diglyphic polyps of this sort



derived from monoglyphic parents, and nine derived from diglyphic parents. The possible exception mentioned was a diglyphic polyp of diglyphic parentage which had two pairs of directive mesenteries, both apparently in the new tissue. Yet the limits of the old tissue could not in this case be located with certainty, and it is possible that one of the two pairs had really been derived directly from the parent fragment. Otherwise we must suppose that regeneration had taken place in such a way as to produce simultaneously out of new tissue two pairs of directive mesenteries. That such a thing probably occurs sometimes is indicated by the observation once in a great while of a *triglyphic* individual, a condition which would be reached if a fragment already containing a pair of directive mesenteries acquired two more by regeneration. The triglyphic condition may, however, arise in a different way, *viz.*: by laceration of a diglyphic polyp, which then produces in the area of regeneration a new or third siphonoglyph system.

It still remains to account for the fact shown in Table II that more diglyphic polyps are produced by diglyphic than by monoglyphic parents. A moment's reflection will show that this is not difficult. If pieces are cut at random from the bases of polyps without reference to the position of the directive mesenteries, it is evident that directives are likely to be included in the fragment removed, twice as often when the parent polyp is diglyphic as when it is monoglyphic, since the diglyphic polyp contains *two* directive systems on opposite sides of the body, whereas the monoglyphic polyp contains only one. Accordingly we should expect the proportion of diglyphic polyps regenerated to be about twice as great in one case as in the other. The observed proportions are not greatly at variance with this expectation.

In order to test more fully and directly the hypothesis already presented,—that the condition of a regenerated polyp, whether monoglyphic or diglyphic, depends on whether the parental fragment did or did not contain portions of the directive mesenteries,—advantage was taken of the fact that in the experiments summarized in Table II certain fragments had been cut from the bases of parent polyps in such a way as to include a pair of directive mesenteries, and others had been cut in such a way as not to include directives in the fragment removed, the two lots having been reared separately. In the former lot unfortunately the

mortality was high, because of unfavorable conditions in the aquarium in which they were placed, and only three polyps survived. Further, two of these were insufficiently regenerated to show the character of the new mesenteries, but the third was clearly a diglyphic polyp with one pair of directives in the old tissue and one in the new, as expected.

The fragments cut so as to exclude directives did somewhat better. Ten polyps were reared from them. Eight of the ten were clearly monoglyphic, with the directives always in the new tissue; a ninth polyp was insufficiently regenerated, but it had a pair of mesenteries on the regenerated side, which gave some indications of being directives. If so, this polyp is similar in character to the eight previously mentioned; if not, it is aglyphic. The tenth polyp was diglyphic, but quite asymmetrical in character, one of the two pairs of directive mesenteries arising close to the boundary between the old and the new tissue. It is impossible to say whether a pair of directives was accidentally included in the fragment from which this polyp developed or whether there arose simultaneously two areas of regeneration, each of which produced a pair of directive mesenteries.

This direct experiment, incomplete though it is, supports the hypothesis based on the experiments previously described. It indicates that the dimorphism found in *Metridia* asexually produced is not dependent upon the monoglyphic or diglyphic character of the parent polyp, but upon whether the parent fragment does or does not contain a portion of a siphonoglyph system. It harmonizes, likewise, with the observations of Carlgren ('04) on regeneration in *Sagartia* and other actinians and supports the idea advanced earlier by Carlgren ('93) and supported by Parker ('97), that the dimorphism of actinians is an incident of asexual reproduction.

As a control of the experiments examination was made of nine spontaneously regenerated polyps collected at Lynn, Mass. This yielded results closely similar to those obtained from the artificially regenerated polyps. One of the polyps was indeterminable; one was diglyphic, with one pair of directives in the old and one in the new tissue; and seven were monoglyphic. Of the seven monoglyphic polyps, five had the directives attached to what was unmistakably the regenerated portion of the body-wall, while in the remaining two old and new tissue could not be

distinguished on account of the advanced state of regeneration of the polyps.

The frequent occurrence of asexual reproduction in *Metridium* explains the prevailing asymmetry of individuals in this species, regenerated diglyphic polyps in particular being rarely symmetrical. It is usual to find the mesenteries arranged with more primaries and secondaries on one side of the plane passing through the siphonoglyphs than on the other. This condition is to be explained by the fact that fragments, either spontaneously produced or formed artificially by random cuts from the base of the foot-disc, arise without any definite reference to the parental mesenteries which traverse that region. Hence, if the directive mesenteries chance to be nearer one end of a fragment than the other or if the new directives are formed nearer one edge of the regenerated area than the other, an asymmetrical polyp results.

The idea which has been advanced in the foregoing pages is capable of giving an explanation also of the great variation in the numerical proportions of monoglyphic and diglyphic polyps in different localities. (See Table I.) If we suppose that in certain localities, like Newport, R. I., or at particular seasons of the year sexual reproduction is favored, regular hexamerous diglyphic polyps should at such places or seasons be relatively more abundant. Torrey ('02) correctly explains as due to asexual reproduction patches of similarly colored sea-anemones, but the occurrence of diglyphic individuals among polyps asexually produced does not, as he supposes, show that the diglyphic character has been inherited as such, but rather that in these particular cases the parental fragments happened to include a directive system. The diglyphic hexamerous polyp of *Aiptasia*, described by Andres and cited by Torrey ('02) as "evidence to be explained," may be explained on the same basis. The dimorphism which, according to Torrey ('02), occurs in polyps produced by budding from the column of sea-anemones is doubtless capable of explanation in a similar way.

The production in the experiments here described of polyps with a divided œsophagus and perhaps, in other cases, of two directive systems formed simultaneously in the regenerated tissue are worthy of notice as giving a clew to the origin of double monsters and of triglyphic polyps. Both of these abnormal conditions well known in collections of polyps, doubtless arise in spontaneous

asexual reproduction, since the processes leading up to them have been observed in regeneration artificially induced. In view of these facts it is improbable, as has been supposed by several investigators, that double Metridia are a stage in a process of reproduction by longitudinal fission. The older view that they are genuine monstrosities seems better supported, but not the view that they are due to coalescence, as was once thought to be the case.

From long strips cut from the margin of the foot-disc and including a half or more of its circumference, polyps with two or three distinct oral discs have several times been obtained in these experiments. This result throws still further light on the origin of double monsters.

#### SUMMARY.

The dimorphism which occurs in *Metridium* is due not to alternative inheritance of the diglyphic and monoglyphic conditions, but to the frequent occurrence of asexual reproduction. This takes place spontaneously by basal fragmentation and may readily be induced by cutting off pieces of the foot-disc. Whether a particular fragment produces a monoglyphic or a diglyphic polyp depends, not on the monoglyphic or diglyphic condition of the parent polyp, but upon whether the fragment does or does not contain some portion of a directive system, for a directive system is regularly produced in the regenerated portion of the young polyp. Accordingly, if the portion derived from the parent already contained a directive system, the young polyp will have two such systems and will be diglyphic. But if the parental fragment contained no directives, the young polyp will have only one directive system, that produced in regeneration, and will be monoglyphic.

Not only the dimorphism of *Metridium*, but also its prevailing asymmetry and extreme variability in number and arrangement of mesenteries can be explained by its method of development in asexual reproduction. Triglyphic polyps and those with two or more oral discs or with double or branched œsophagus or devoid of siphonoglyphs are abnormalities due probably to regeneration from fragments of unusual size or shape, as compared with the fragments normally produced in spontaneous basal fragmentation.

BIBLIOGRAPHY.

- CARLGREN, O., '93.—Studien über nordische Actinien. Königl. svenska Vet.-Akad., Handl., N. F., Bd. 25, No. 10, 148 pp., 10 Taf.
- '04.—Studien über Regenerations- und Regulations-Erscheinungen. Königl. svenska Vet.-Akad., Handl., N. F., Bd. 38, No. 8, 84 pp. 22 Fig., 10 Taf.
- DIXON, G. Y., '88.—Remarks on *Sagartia venusta* and *Sagartia nivea*. Sci. Proc. Roy. Dublin Soc., N. S., vol. 6, pp. 111-127.
- McMURRICH, J. P., '89.—The Actinaria of the Bahama Islands, W. I. Jour. of Morph., vol. 3, no. 1, pp. 1-80, pl. 1-4.
- PARKER, G. H., '97.—The Mesenteries and Siphonoglyphs in *Metridium marginatum* Milne-Edwards. Bull. Mus. Comp. Zoöl. Harvard Coll., vol. 30, no. 5, pp. 259-273, 1 pl.
- '99.—Longitudinal Fission in *Metridium marginatum* Milne-Edwards. Bull. Mus. Comp. Zoöl., Harvard Coll., vol. 35, no. 3, pp. 41-56, 3 pl.
- THORELL, T., '59.—Om den inre byggnaden af *Actinia plumosa* Müll. Öfversigt Königl. Vet.-Akad., Förhandl., Årg. 15, 1858, pp. 7-25, Tab. 1.
- TORREY, H. B., '98.—Observations on Monogenesis in *Metridium*. Proc. Cal. Acad. Sci., ser. 3, Zoöl., vol. 1, pp. 345-360, pl. 21.
- '02.—Papers from the Harriman Alaska Expedition. XXX. Anemones, with a Discussion of Variation in *Metridium*. Proc. Wash. Acad. Sci., vol. 4, pp. 373-410, pl. 34, 35.



## THE EFFECT OF VARIOUS SALTS UPON THE SURVIVAL OF THE INVERTEBRATE HEART.

BY

CHARLES G. ROGERS.

WITH 1 PLATE.

The cause which underlies the rhythmic contraction of the heart has been the subject of much controversy. In recent years the importance of the inorganic compounds of the blood has been acknowledged by most physiologists, but the rôle of each of these different salts in originating and maintaining rhythmic contractions has caused much discussion. Up to the present time almost all of the work done upon the physiology of the heart has concerned vertebrates alone.

It was, therefore, a pleasure to follow the kind suggestion of Dr. Loeb and use the heart of an invertebrate as the subject upon which to conduct a series of experiments which may furnish an answer to the following questions: What is the influence of the various salts, found in the blood, upon heart action? And, is this influence the same in the crab as in the heart of the vertebrates?

I wish to express my thanks to Dr. Loeb for suggesting the problem and for many kind criticisms during the course of the work.

### METHODS.

In the study of the problem the hearts of the marine crab *Brachynotus nudus* were employed. This crab is found very abundantly along the western shore of San Francisco Bay, beneath rocks, between tide marks. The crabs may be kept in the laboratory for a considerable period without serious deterioration and hence prove to be an admirable form upon which to work.

In carrying out these experiments three general methods of procedure have been employed, of which two, however, were

soon discarded. The first consisted in carefully isolating the hearts in watch glasses, each containing about ten cc. of the solution to be tested, and making observations upon the number and quality of the beats developed. This method was employed only during the early stages of the work as it did not permit of any accurate estimate of the amount of work done by the heart. The second method was that of carefully suspending the hearts by means of delicate glass hooks in connection with light recording levers and allowing them to trace upon smoked papers the records of their contractions. In these experiments the hearts were moistened with the solutions by means of camel's hair brushes. Oxygen, of course, is easily taken up from the air, but the effects of the various constituents of the solutions are difficult to determine with this method as the amount of solution in contact with the heart is small and variable. One can not be sure at any given time that the solution has replaced the body liquid normally present. In view of this fact a third method was employed. This was similar to the second except that the hearts were immersed in tubes, each containing about 30 cc. of the solution. While the general results of the first method agree with those of the third they are disregarded in the final summing up of the work as lacking in sufficient accuracy. The second method failed to give uniform results. The author feels that the results obtained by the third method are far more reliable than those obtained by either of the preceding ones, hence they form the basis of the following report.

#### EXPERIMENTS.

##### A. *What is the Optimum Concentration of Salt Solution which will Favor the Rhythmic Activity of the Heart?*

Botazzi<sup>1</sup> has measured cryoscopically the osmotic pressure of the blood of many of the marine invertebrates and has found that it is practically the same as that of the sea water. The average depression of the freezing point in the body liquids of invertebrates is given by Hamburger<sup>2</sup> as  $-2^{\circ}.29$ , and the depression of the freezing point of the sea water is given by Höber as  $-2^{\circ}.3$ .

<sup>1</sup>Botazzi. Archives Italiennes de Biologie, xxviii, 1897, p. 67.

<sup>2</sup>Hamburger. Osmotischer Druck und Ionenlehre in den Medicinischen Wissenschaften.



The NaCl solution having the same osmotic pressure contains 3.783 per cent of NaCl, or is a solution of about  $\frac{3}{8}$  m. concentration. In bays and in the mouths of rivers the osmotic pressure of the sea water becomes greatly modified. Dr. Loeb<sup>1</sup> has shown that animals taken from the waters of San Francisco Bay thrive in solutions with an osmotic pressure approximately equal to that of a  $\frac{3}{8}$  m. NaCl solution. The animals upon which the present work was carried out were collected at a point about three miles north of the Golden Gate where the water sweeps by at both flood and ebb of tide in strong currents. At flood tide the water has nearly the same concentration as the water of the open ocean, but at ebb tide it is much freshened by the water of the Sacramento River.

A series of experiments was made to determine the concentration of a solution of NaCl which would favor the rhythmic contraction of the heart. For this purpose a  $\frac{5}{8}$  m. NaCl solution was employed and this was diluted with distilled water in varying amounts. It might be expected that the beats, if any at all appeared, would continue longest in that concentration of NaCl which most nearly approaches the normal concentration of the blood of the animal. As a result of a long series of trials it was found that a  $\frac{3}{8}$  m. and a  $\frac{7}{16}$  m. solution of NaCl acted most favorably. Both of these concentrations were employed in the further work.

#### B. *Is NaCl Essential for Maintaining Rhythmic Contractions?*

In considering the question whether any substance is essential for the origination of rhythmic contractions the following condition must be kept in mind: In order to demonstrate that a substance is necessary for the origination of rhythmic beats in a muscle we must employ a muscle which does not beat rhythmically when it is removed from the body. Dr. Loeb<sup>2</sup> has shown that this is true in the case of the center of the bell of the medusa *Gonionemus*, and was able to demonstrate that NaCl is essential for the origination of rhythmic contractions in this muscle. The

<sup>1</sup>Loeb, J. *Pflüger's Archiv.*, vol. xcvi, 1903, p. 394. Also University of California Publications, *Physiology*, vol. i, No. 7, pp. 55-69.

<sup>2</sup>Loeb, J. *American Journal of Physiology*, vol. iii, 1900, p. 383.

ventricle of the heart of the turtle also does not exhibit rhythmic contractions when it is removed from the body of the animal and in this case also Lingle<sup>1</sup> was able to show that the development of rhythmic contractions depended upon the presence of NaCl. Lingle also emphasized the necessity of a large supply of oxygen. Overton<sup>2</sup> working independently, and apparently not having seen the reports of the work already mentioned found that in the absence of NaCl, *e. g.*, in a pure sugar solution muscle does not respond to electrical stimuli.

In the present work we are dealing with a heart of a single chamber and one that continues to beat when it is removed from the body of the animal. We can, hence, only raise the question whether the heart of the crab will continue to beat for a long time in the absence of NaCl while with this salt present it will continue to beat for a much longer period. We may also raise the question whether when the contractions of the heart have ceased in some solution lacking in NaCl the addition of NaCl will cause rhythmic contractions again to take place.

In order to show whether the hearts of the crabs depend upon the presence of NaCl to maintain rhythmic contractions they were immersed in solutions lacking in this salt, but in which the osmotic pressure was kept approximately at the normal height by means of cane sugar. In some experiments no oxygen was added to the solution in others hydrogen-peroxide was added, following the experiments of Lingle, and in others a current of gaseous oxygen was allowed to bubble through the solution. As the result of these experiments it was found that the fresh hearts of the crab do not cease beating at once when placed in a pure sugar solution and that the length of time during which such contractions may continue is somewhat extended by the presence of oxygen. In no case, however, did the heart in such a solution continue to beat for more than one hour and in the very great majority of cases not more than twenty minutes. There seemed to be no great difference in the action of the hearts when the concentration of the solutions varied between  $\frac{3}{8}$  m. and  $\frac{5}{8}$  m. In a sugar solution the beats are at first not weakened but very soon they lose in strength and soon cease altogether. When no oxygen is

---

<sup>1</sup>Lingle, D. American Journal of Physiology, vol. viii, p. 75 ff.

<sup>2</sup>Overton. Pfluger's Archiv., Bd. 92.

added to the solution the beats are of regularly decreasing amplitude until finally no contraction is visible. When the oxygen supply is ample it frequently happens that the last beats have perhaps one-third of the amplitude of the normal contraction, but they occur at regularly increasing intervals until they cease altogether.

In some cases irregularities of beat occur. These may be due to injuries received by the heart when it was removed from the body of the animal or from a deficient supply of oxygen. A very marked effect of the cane sugar is the great increase of muscular tone which occurs in all hearts immersed in such solutions.

If, as has been held by some, NaCl is the substance which is necessary for the development of rhythmic contractions we should find upon adding NaCl to the sugar solution that the length of time during which a heart will continue to beat will be lengthened as we increase the amount of the salt, up to the limit of the concentration in which this salt exists in the sea water. In order to test this varying amounts of  $\frac{3}{8}$  m. NaCl were added to a  $\frac{3}{8}$  m. cane sugar solution and it was found that as the proportion of NaCl in the solution increased the hearts beat for a longer time.

The following examples will illustrate:

No. 222—25 cc.  $\frac{3}{8}$  m. NaCl plus 75 cc.  $\frac{3}{8}$  m. cane sugar beat for 26 minutes.

No. 213—50 cc.  $\frac{3}{8}$  m. NaCl plus 50 cc.  $\frac{3}{8}$  m. cane sugar beat for 35 minutes.

No. 228—75 cc.  $\frac{3}{8}$  m. NaCl plus 25 cc.  $\frac{3}{8}$  m. cane sugar beat for 70 minutes.

(The above experiments were made without adding any extra oxygen to the solutions.)

In a pure  $\frac{3}{8}$  m. NaCl solution the hearts beat on the whole longer than in the mixtures of NaCl and cane sugar.

It now becomes of interest to know whether other substances than the NaCl have the power to aid in the maintenance of rhythmic contractions when added to a solution of cane sugar. On account of the importance of calcium, potassium and magnesium for marine animals we naturally turned first to these in order to answer the question. Small and varying amounts of the chlorides of these metals were added to solutions of cane sugar and records made of the heart contractions under the influence of these solutions.

C. *The Effect of the Addition of Calcium Chloride to a Sugar Solution.*

Small amounts (.5 cc. to 3.00 cc.) of a  $\frac{5}{16}$  m.,  $\frac{3}{8}$  m., or  $\frac{7}{16}$  m. calcium chloride solution added to 100 cc. of  $\frac{3}{8}$  m. cane sugar solution in which a heart may be immersed modify very materially the action of the heart. The beats become more uniform in quality and occur at more regular intervals than when the heart is immersed in a pure sugar solution. At the same time it seems probable that the length of time during which a heart will continue to beat in such a solution is somewhat lengthened. It is difficult to make a definite statement with regard to this last point, however, on account of large individual variations in the actions of different hearts. A very characteristic effect of the addition of calcium is seen in the gradual retardation of the beats, the contractions coming at regularly increasing intervals until they stop altogether. In some cases instead of this retardation we may find a progressive decrease in the amplitude of the beats while the rate remains fairly constant.

If larger amounts of calcium chloride be added to the solution there is a very evident poisonous effect exerted upon the heart by the salt and in a pure calcium chloride solution the effect becomes very marked, the hearts continuing to beat for only a very few minutes even though a large supply of oxygen be available.

D. *The Effect of the Addition of Potassium Chloride to a Sugar Solution.*

The addition of small amounts of a  $\frac{5}{16}$  m. solution of potassium chloride to a solution of cane sugar in which hearts are immersed brings about a marked increase in the amplitude of the contractions. At first the beats occur much more rapidly than in the pure sugar solution and these contractions are very powerful. After the first series of very strong contractions, which lasts for only a few minutes (eight or nine at the most) comes a series of contractions of nearly normal amplitude but somewhat more rapid than usual. Following these but coming more slowly is another series of exceedingly strong contractions which is finally followed by a rapid decline in the amplitude of the beats.

Coincident with this decline is the characteristic increase of muscular tone generally associated with the action of the sugar solutions. A particular feature of the action of solutions containing potassium is that a single muscle twitch occupies much less time than when the muscle is immersed in a pure sugar solution, or even in other solutions in which the amount of potassium is much less.

E. *The Effect of the Addition of Magnesium Chloride to a Sugar Solution.*

When small amounts of a  $\frac{5}{16}$  m. solution of magnesium chloride are added to a solution of cane sugar in which the hearts are immersed it is found that the quality of the contraction becomes modified although the length of time during which the heart will continue to beat is not altered. The first contractions are usually stronger than normal. After a short series of these powerful beats the beats lost strength and became somewhat irregular, and finally were weak and rapid, with occasional strong contractions scattered among the much weaker ones.

F. *The Effects of the Addition of Calcium and Magnesium to a Sugar Solution.*

Small amounts of  $\frac{3}{8}$  m.  $\text{CaCl}_2$  and a  $\frac{3}{8}$  m.  $\text{MgCl}_2$  solution added to a solution of cane sugar have a marked influence upon the action of a heart immersed in such a solution. The beats become more regular as to time and intensity and the average length of time during which the heart will continue to beat is greater than in the solution with either one salt alone.

G. *The Effect of Sodium Chloride and Calcium Chloride.*

While in a pure  $\text{NaCl}$  solution the heart tracings are very similar to the fatigue curves of voluntary muscle, as has been noted by other observers upon other hearts, the addition of a slight amount of a  $\frac{3}{8}$  or  $\frac{7}{16}$  m. solution of calcium chloride exerts a profound influence upon the heart action. The cardiac

contractions become more regular in time and amplitude and last for a longer time than when the heart is immersed in pure NaCl alone. This may be due to one of two causes: either the calcium is necessary in itself for the long continuance of the contractions or it may be necessary to counteract the poisonous effects of the NaCl. A record of a single experiment will indicate the trend of results. The heart was immersed in a solution containing 100 cc.  $\frac{7}{16}$  m. NaCl plus 3 cc.  $\frac{7}{16}$  m.  $\text{CaCl}_2$ . These proportions are the same as regards these two salts as were used later in the optimum solution. In this solution the beats continued for a period of more than two hours, probably for more than three but owing to a mechanical defect the heart tracing is imperfect. The record indicates however the main fact which is to be demonstrated—that the addition of calcium chloride to a solution containing sodium chloride renders that solution less harmful. In no case did a heart continue to beat for so long a time in a pure sodium chloride solution as in the experiment just mentioned.

Whether any other salt may be found to fully take the place of the calcium chloride in the solutions I am at present unable to say. Up to this time none has been found.

#### H. *Will NaCl Restore to Activity Hearts Which Have Ceased Beating in Other Solutions?*

A heart immersed in a solution containing 100 cc.  $\frac{3}{8}$  m. cane sugar and .5 cc.  $\frac{5}{16}$  m.  $\text{CaCl}_2$  beat regularly for a period of fifteen minutes, the beats becoming gradually retarded during that time. During the next fifteen minutes only one contraction was recorded. At the end of half an hour the heart was immersed in a  $\frac{7}{16}$  m. NaCl solution and rhythmic contractions began at once and continued for about an hour and a half, becoming more rapid and of less amplitude toward the end of the series. It ought to be stated that in this case the response was unusually prompt and long continued.

In another case an immersion for 50 minutes in a solution containing 100 cc.  $\frac{3}{8}$  m. cane sugar, .5 cc.  $\frac{5}{16}$  m.  $\text{CaCl}_2$  .75 cc.  $\frac{3}{8}$  m.  $\text{MgSO}_4$ , and a slight amount of hydrogen peroxide sufficed to bring the heart to a standstill. The heart was then immersed in a solution of  $\frac{7}{16}$  m. NaCl and after a latent period of twelve

minutes contractions were resumed. At first these contractions were very weak and of little amplitude, but they gradually became stronger, and later diminished in the manner common to hearts immersed in a pure solution of sodium chloride.

The substitution of what is termed later in the paper the "optimum solution" failed to restore rhythmic contractions in hearts which had ceased beating in a sugar solution.

A large number of experiments were made to discover if hearts which had ceased beating in a pure NaCl solution could be made to beat again by some other solution. In no case were beats resumed after they had stopped in a pure NaCl solution. This might seem to indicate that in this case irreversible compounds are formed in the tissues of the heart under the influence of the sodium chloride which will not allow rhythmic activity to proceed.

#### J. *The Effect of Hydrogen Peroxide and of Oxygen in Solutions.*

During the course of the experiments it became evident that in some cases at least the failure of the heart to respond to the solutions was due to an insufficient supply of oxygen. Even when well aerated the solutions contain less oxygen than does the blood by which the hearts are normally surrounded. Lingle<sup>1</sup> found that the addition of small amounts of hydrogen peroxide to his solutions aided very materially in the long continuance of the heart beats. My own experiences confirm his results in this regard. In fact it seems safe to say that without a good supply of oxygen the heart beats are impossible.

In many experiments made with sodium chloride as the principal agent there was noticed a very marked loss of tone as the heart continued to beat. At first this was attributed entirely to the action of the NaCl but later it seemed more probable that the loss of tone was, partly at least, due to the lack of oxygen. Hearts beating in a solution lacking in oxygen show marked fatigue in a short time and finally cease entirely to beat. Such hearts may be revived and again caused to contract rhythmically by simply adding to the solution in which the heart is immersed a little hydrogen peroxide. The following experiment will illustrate the point in question: When a heart was immersed in what I have

<sup>1</sup>Lingle. *Loc. cit.*

shown elsewhere to be the "optimum solution" plus hydrogen peroxide or plus gaseous oxygen it would continue to beat for a period ranging from 20 to 30 hours. To show the effect of the oxygen a heart was immersed in such a solution *lacking in oxygen*. At first the beats were quite strong but became weaker rapidly and within forty minutes had ceased entirely. When the heart had been in the solution for fifty minutes it was immersed in another solution of the same composition but containing hydrogen peroxide. After a latent period of about an hour and a half contractions were again resumed, becoming gradually stronger till they had reached a maximum which was steadily maintained. When this heart had been beating steadily for one and three-fourths hours it was again immersed in the solution lacking in oxygen. The contractions were almost immediately slowed and were later reduced in amplitude. After being in this solution for fifteen minutes and the beats had become very feeble the heart was again placed in the solution containing the hydrogen peroxide. After a few minutes of weak contractions it again recovered and continued to give maximum contractions for some hours. The exact length of time during which the beats continued was not taken.

If instead of adding hydrogen peroxide to the solution we allow a current of gaseous oxygen to bubble through it, taking care that the bubbles do not cause sufficient agitation of the solution to mechanically stimulate the heart to contraction, we find that the heart will make use of the oxygen held in the solution and continue to beat for a long time. (See Fig. 4.)

#### K. *The Effect of Van't Hoff's Solution.*

Van't Hoff has given us the formula showing the relative proportions of the various salts in the sea water. Calcium is, according to his statement, the only considerable variant. The other salts exist in the following proportions: NaCl 100, KCl 2.2, MgCl<sub>2</sub> 7.8, MgSO<sub>4</sub> 3.8.

If, as has been supposed, these salts exist in the blood and body liquids of the crab in the same proportions in which they are found in the sea water and the heart of the crab derives its stimulus from such a solution, then an artificial solution containing these salts



in the proportions mentioned should be as favorable for the continuance of rhythmic contractions as the blood itself provided we add to it the amount of calcium which is usually found in the sea water in which the animal occurs. Analyses of the sea water showed that the amount of calcium chloride present in the sea water of San Francisco Bay is about one for every one hundred of sodium chloride. The addition then of a corresponding amount of calcium chloride to the Van't Hoff solution should render that solution favorable for the life of the hearts. A series of experiments with solutions containing sodium, potassium and magnesium in the proportions stated and with calcium as a variant were made. The amount of calcium chloride used ranged from .5 cc. to 3.25 cc. for every 100 cc. of NaCl of the same molecular concentration ( $\frac{7}{16}$  m.) As the result of these experiments it seems safe to say that the heart of the crab will continue to beat for a long time only in a solution which contains a greater proportion of calcium chloride than the sea water. In the following experiments the sodium chloride, magnesium chloride, magnesium sulphate, and potassium chloride were employed in the proportions stated above, the concentration of the solutions being  $\frac{7}{16}$  m. Various amounts of  $\frac{7}{16}$  m. calcium chloride were added as indicated:

Exp. 349—	1.0 cc. CaCl <sub>2</sub>	to 100 cc. NaCl,	heart beat for 50 minutes.
Exp. 384—	1.5 cc. “ “ “	“ “ “	“ “ “ “ 90 minutes.
Exp. 387—	2.0 cc. “ “ “	“ “ “	“ “ “ “ 6 hrs. or more.
Exp. 513—	3.0 cc. “ “ “	“ “ “	“ “ “ “ 18 hours.
Exp. 515—	3.25 cc. “ “ “	“ “ “	“ “ “ “ 30 “

(See Figs. 1, 2 and 3.)

The above figures do not give an adequate idea of the improvement in the action of the hearts caused by the increase in the amount of calcium in the solution. There is a very marked improvement in the quality of the beats, and the regularity of the contractions in addition to the increase in the length of time during which the contractions may continue as the greater amounts of calcium are added. That a part of the effect of the calcium consists in neutralizing the poisonous effect of the KCl in the solution was shown when the amount of KCl employed was less than that called for by the formula. In such cases the amount of calcium

chloride needed to make a well balanced solution was less than when the full amount (2.2 cc.) was used.

When we employ a solution containing sodium, potassium and magnesium in the proportions in which they exist in the sea water and add a sufficient amount of calcium to neutralize the poisonous effects of these salts we find that the beats exhibit a remarkable uniformity of contraction which is long continued. When more than 3.0 cc. of calcium chloride is added to 100 of sodium chloride we find that the amplitude of the contractions is lessened, but the beats are slower, more nearly the normal rate, and continue through a longer period than in any of the solutions containing less of the calcium.

#### L. *The Effect of Sea Water as a Nutrient Solution.*

In Van't Hoff's solution of  $\frac{7}{16}$  m. concentration we have been using the various salts in the proportions in which they exist in the sea water, as it is found in the bay. If the concentration of the various salts in the blood of the animal is the same as in the sea water by which they are normally surrounded we should find that when a heart is immersed in sea water it would beat as well as in our artificial solution. The water used in this series of experiments was taken from the open ocean and hence of higher concentration than the water of the bay. In order to reduce the osmotic pressure of this water to about that of the water of the bay it was diluted with distilled water. It was found that the most satisfactory results were obtained when 85 cc. of sea water and 15 cc. of distilled water were used. But even this dilution did not give a solution which was so favorable for the action of the hearts as was the artificial solution. In the diluted sea water all the hearts behaved like hearts immersed in solutions containing too much NaCl or too little CaCl<sub>2</sub>. As we have already shown the sea water contains about one part of calcium chloride for every one hundred of sodium chloride. But the artificial solution which had been found most favorable for the long continued heart action contained at least three parts of calcium chloride to every one hundred of sodium chloride. If now we add to the diluted sea water small amounts of calcium chloride so as to raise the proportion of this salt to about that which we have in our

artificial solution we should have a solution which would be equally as good as the artificial solution in its action upon the heart of the crab. This was indeed found to be the case. The heart beats became more regular and the length of time during which the heart would continue to beat was much increased. The solution now proved to be in every particular the equivalent of the artificial solution. This suggests the possibility that the concentration of the  $\text{CaCl}_2$  in the blood of the crab, and also the concentration of this same salt necessary for long continued heart action is higher than that of the sea water.

M. *The Rôle of Sodium Bicarbonate and Sodium Hydrate in Artificial Solutions.*

It was found during the course of the experiments that the addition of small amounts of sodium bicarbonate to the solutions employed had a very beneficial effect upon the action of the hearts. For a time it was thought that this substance was in itself a necessary component of the liquids intended to favor rhythmic activity. Dr. Loeb<sup>1</sup> has shown that the sea water is practically neutral in reaction. How the bicarbonate could affect the action of the heart was a puzzle until it was remembered that very small amounts of free acids in artificial solutions may exert very injurious effects. The rôle of the bicarbonate in neutralizing any free acid that may be present in the solutions throws a new light upon the subject and makes its presence desirable. It has the power to neutralize acids and yet is not itself alkaline in reaction. It is therefore possible to have solutions containing an excess of this substance without affecting the neutrality of the solution. By thus neutralizing any free acid which may be present we make the conditions most favorable for heart activity, and add for the proof of the fact that the body liquids are neutral in reaction.

The addition of small amounts of  $\frac{n}{10}$  NaOH will have exactly the same effect. Care has, of course, to be taken not to add too much of this substance as the solution must not be too alkaline in reaction.

---

<sup>1</sup>Loeb, J. Archiv. für die gessammte Physiologie, Bd. 99, 1903, p. 637.

N. *The Substitution of Another Metal for Sodium.*

Dr. Loeb<sup>1</sup> has shown that in the case of the skeletal muscles which are made to give rhythmic contractions by means of electrolytes, it is possible to substitute in the place of the sodium another metal, especially lithium. Up to the present time no one has succeeded in making such a substitution in the case of cardiac muscle. A large number of experiments were made using lithium chloride in the place of sodium chloride in the Van't Hoff solution. In no case was it found that rhythmic contractions would continue in such a solution for a longer time than they would in a pure sugar solution.

## SUMMARY AND CONCLUSIONS.

1. The blood of the crab studied, *Brachynotus nudus*, probably has the same concentration as the average of the sea water of the bay.

2. On account of the fact that the heart does not cease beating when it is removed from the body of the animal it is impossible to determine that any substance is essential for the *origination* of rhythmic contractions. It has been demonstrated, however, that such contractions will not long continue when NaCl is absent. Calcium, potassium and magnesium each have an important influence upon the heart contraction.

3. The balance between the salts entering into the composition of the artificial solution, and presumably of the blood also, is a very delicate one and can be determined with great accuracy.

4. Sodium chloride has the power to restore rhythmic contractions in hearts which have ceased beating in some other solutions.

5. Hearts which have ceased beating in a pure NaCl solution do not again beat when placed in a solution lacking in NaCl.

6. The presence of a supply of oxygen in the solutions is necessary for rhythmic contractions. Oxygen may be supplied by adding small amounts of hydrogen peroxide to the solution or by allowing oxygen gas to bubble through it.

7. The solution most favorable for rhythmic contractions of the crab's heart was found to have the following composition:

<sup>1</sup>Loeb, J. Festschrift für Professor Fick, 1899.

100 parts NaCl, 7.8 parts MgCl<sub>2</sub>, 3.8 parts MgSO<sub>4</sub>, 2.2 parts KCl, 3.25 parts CaCl<sub>2</sub>, all of  $\frac{7}{16}$  m. concentration and oxygen. In case the oxygen is added in the form of the peroxide, sodium bicarbonate or sodium hydrate must be added to neutralize the acid introduced with the peroxide.

8. Sea water to which has been added calcium chloride acts in the same way as does the artificial solution.

9. The normal circulating fluid of the crab must contain a larger proportion of calcium than does the sea water.

10. Lithium chloride can not be substituted for sodium chloride in the artificial solutions.

## EXPLANATION OF PLATE.

All records read from right to left. The time marker indicates intervals of thirty seconds.

Fig. 1. Record of a heart beating in a solution containing 100 cc.  $\frac{1}{2}$  m. NaCl, 2.2 cc.  $\frac{1}{2}$  m. KCl, 7.8 cc.  $\frac{1}{2}$  m. MgCl<sub>2</sub>, 3.8 cc.  $\frac{1}{2}$  m. MgSO<sub>4</sub>, 1 cc.  $\frac{1}{2}$  m. CaCl<sub>2</sub>, .75 cc.  $\frac{1}{2}$  m. NaHCO<sub>3</sub> and oxygen. It will be noticed that the first beats were strong, but became rapidly weaker, then slower, finally ceasing in less than an hour from the beginning of the experiment. The curve is characteristic of all hearts beating in solutions in which the amount of Na is too great, or the Ca too small.

Fig. 2. Record of a heart beating in a solution similar to that mentioned above, except that 2 cc.  $\frac{1}{2}$  CaCl<sub>2</sub> were employed. This heart beat for a much longer period than that in the previous experiment. Section *b* of the record was taken two hours from the start *a*; section *c* four hours and section *d* six hours.

Fig. 3. Record of a heart beating in a solution similar to those used in the above experiments except that it contains a larger amount of CaCl<sub>2</sub>, viz: 3 cc.  $\frac{1}{2}$  m. solution. The beats maintain their first strength and rate of contraction for a long period. Section *b* is taken four hours from the beginning of the record, section *c* seven hours, section *d* eleven hours, section *e* eighteen hours and section *f* twenty hours. At the point *x* in section *d* a couple of drops of hydrogen peroxide were added to the solution in which the heart was immersed. Its effect is shown in the ensuing stronger and more rapid contractions.

Fig. 4. Portion of the record made by a heart beating in a solution similar to those above, but containing 3.25 cc.  $\frac{1}{2}$  m. CaCl<sub>2</sub>. The beats shown at *a* are characteristic for hearts beating in such a solution and under ordinary conditions will continue for periods of thirty hours or more. At the point *b* the solution containing oxygen was replaced by one which had been heated to expel the gases in solution and then cooled to the same temperature as the solution first employed. The effect of the lack of oxygen is shown in the regularly decreasing force of contraction. At *c* the heart was again placed in the solution containing oxygen, and after a short time regained its former strength and continued beating for a number of hours. This experiment was repeated frequently with similar results.







EFFECT OF SALTS UPON THE  
INVERTEBRATE HEART.

CHARLES G. ROGERS.



Fig. 1

a

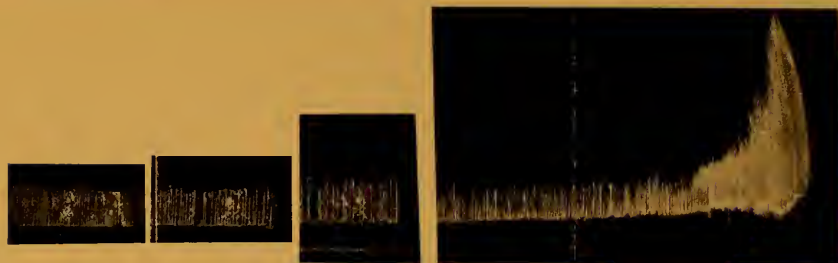

Fig. 2.

d

c

b

a

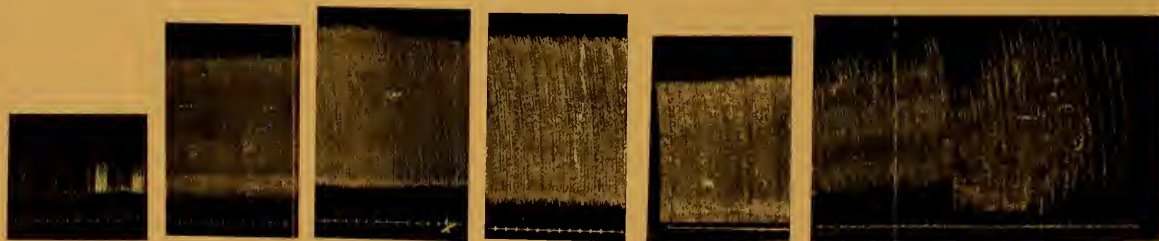

Fig. 3

f

e

d

c

b

a

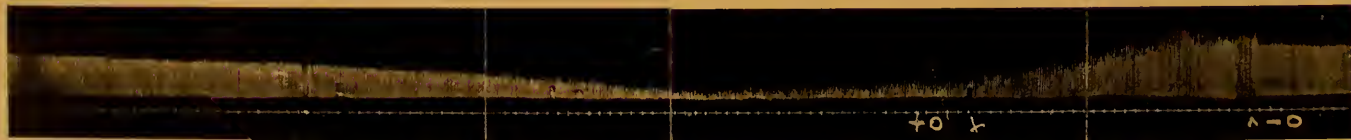

Fig. 4

c

b

a



## STUDIES ON REGULATION.

### VII. FURTHER EXPERIMENTS ON FORM-REGULATION IN LEPTOPLANA.

BY

C. M. CHILD.

WITH 34 FIGURES.

The present paper is devoted to a consideration of certain phases of the process of form-regulation in *Leptoplana*, which, although of great interest when viewed in the light of the conclusions reached in previous papers on *Leptoplana* (Child, '04a, '04b, '04c), do not in themselves afford sufficient data for these conclusions. Considered at this time they serve to confirm and extend the conclusions already drawn from other data.

#### A. TYPICAL CHANGES IN PROPORTION DURING REGULATION.

During the process of form-regulation of pieces in many of the lower animals certain changes of form occur which involve not only the new parts but also the old fully differentiated regions. Under normal conditions these changes consist in approximation to the typical proportions of the species. A description of these changes in *Planaria*, where they are considerable, has been given by Morgan ('00) who has applied to them the term "morphallaxis." I have shown recently (Child, '02, '03) that similar changes in *Stenostoma* are at least in part the result of traction upon the parts in certain directions in consequence of the characteristic motor activity and I have obtained strong evidence as yet unpublished, that the same factors are concerned in *Planaria*. But the term "morphallaxis" has been applied to phenomena which, in my opinion, are wholly diverse and therefore, although I have employed it in certain previous papers (Child, '02, '03a, '03b), it seems preferable to use some less vague term. Driesch ('01) considers "morphallaxis" identical with his "Restitution durch Umdifferenzierung," but morphallaxis may occur without

any "redifferentiation" as in the case of *Gonionemus* (Morgan, '99).

Some term is necessary to denote those changes of form in the Turbellaria and other groups which are primarily mechanical and connected with motor activity. There is no fundamental difference between such changes in the new parts and in the old. Both, as well as many other regulative phenomena, may be included under the head of mechanical regulations (Child, '02). The fact that the typical proportions usually result is merely incidental. I have shown ('02) that in the absence of the locomotor tensions the result may be exactly the reverse. Until opportunity offers for a more extended discussion of this matter I prefer to designate these changes merely as changes in proportion.

During form-regulation in *Leptoplana* changes in proportion similar to those occurring in *Planaria* and *Stenostoma* occur. In pieces containing the cephalic ganglia changes are considerable, though not as great nor as rapid as in *Planaria* and *Stenostoma*, a difference which is evidently due to the fact that the tissues of *Leptoplana* are less soft and plastic than those of the other forms mentioned. The changes consist in relative elongation and reduction of the transverse diameter, especially toward the posterior end.

In order to make clear my point of view in these experiments it is necessary to refer briefly to earlier experiments on *Stenostoma* and *Leptoplana* (Child, '02, '03a). In the case of *Stenostoma* I found that the changes in form and proportion of the pieces during regulation, *i. e.*, the elongation and the change from cylindrical to conoidal form were due primarily to the tension upon the tissues consequent upon the use during locomotion of the posterior end as an organ of attachment. It was possible to inhibit or retard the change in proportions by preventing the pieces from attaching themselves to the substratum (Child, '03a). In *Stenostoma* the changes in proportion are much more rapid than in other forms examined, being completed in many cases in twenty-four to thirty hours.

In my first paper on *Leptoplana* (Child, '04a) a brief description of the method of locomotion was given, certain points of which must be recalled to mind. In creeping, *Leptoplana* uses the margins of the head region for drawing the body forward,

while the margins of the body from about the middle or a little anterior to it, to the posterior end are employed as organs of attachment, the most posterior part, the "tail" being most frequently used in this manner. The body of the animal is frequently subjected to tension during creeping and I believe that, as in *Stenostoma*, this tension is of considerable importance in determining the general form. Its effect upon the newly formed regenerating parts has already been discussed (Child, '04b, '04c). We have now to consider the changes in proportion of the old parts during regulation and to discuss the rôle of mechanical factors in these changes. Since the changes are slow it is impracticable to control them by preventing the animals from attaching themselves to the substratum, as was done in the case of *Stenostoma*, but modification of the changes is possible by certain methods which will be described below.

In *Stenostoma* (Child, '02) the posterior region of the body is subjected most frequently and in greatest degree to tension, but in *Leptoplana* the lateral margins of the body as well as the posterior end are used for attachment, so that very frequently only the anterior portions of the body are subjected to tension, the whole posterior portion being attached. However, the posterior end is usually the first part to attach itself and the last to be released, hence in the long run it is undoubtedly more stretched than other parts. It is probable that the outline of the body of *Leptoplana* is due in large part to the mechanical factors connected with attachment and locomotion. A form which like *Stenostoma* uses only the posterior end and the median ventral region for attachment must be slender and only slightly tapering in the definitive condition, while on the other hand a species which uses the margins of the body for attachment will be broader and the decrease in breadth toward the posterior end will depend upon the relative frequency with which the lateral margins and the posterior end alone are used for attachment. In *Leptoplana* the posterior end is still the principal organ of attachment and the body possesses a tapering form as it must according to mechanical principles if it is plastic. But in such forms as *Stylochus* where the whole margin is used as an organ of attachment and the posterior end is used with no greater frequency than other parts the form of the body becomes ovoid or almost circular. (See Child, '04a.) The

more frequently the lateral margins are extended laterally and attached, the broader does the body of the worm become.

When a part of the body of *Leptoplana* is isolated from the other parts it is necessary to consider the particular conditions in each case before we can understand the changes that occur. The mechanical conditions connected with locomotion will differ according to the region of the body from which the piece is taken, since different regions show different behavior as regards attachment and, what is more important, the kind and degree of change in the direction and amount of tension to which the tissues are subjected, will differ greatly according to the regions of the body involved, the amount and kind of movement and various other conditions. Usually observation of the pieces during locomotion is the only satisfactory method, for this is the only way of determining how a particular piece uses a certain part or when it begins to use the regenerated tissues in locomotion.

All figures are drawn from careful measurements made when the specimens were fully extended, the following measurements being made in each case, where the parts mentioned were present: length of animal or piece, distance from anterior end of head to middle of groups of eyes, distance from anterior end of head to anterior end of pharynx, length of pharynx, length of new tissue, width of head at widest part, width of head at level of eyes, width of body at posterior end of pharynx, width of body 1-2 mm. anterior to cut surface, *i. e.*, just anterior to the region which has contracted in consequence of the cut, width of new tissue at cut surface, one or two other measurements of width of new tissue at different levels according to form of this part. While the specimen was under observation figures were drawn from the measurements in order that local curvatures and other special features not indicated by the measurements might be recorded; the extent of the intestinal branches in the new tissue was also indicated in the figures.

### 1. *Experiments.*

From some twenty-five series of experiments concerning the changes in proportion four have been selected which show the results obtained after section at different levels of the body. In order to permit direct comparison the more important measurements of these series are grouped in tabular form. All measure-

ments given are reduced to millimeters. The table gives simply the measurements of the pieces concerned; not of the whole animal from which they were taken. The first measurements of

TABLE OF MEASUREMENTS.

Series.	Time.	Length of piece.	Length of new tissue.	From anterior end to eyes.	From anterior end to pharynx.	Length of pharynx.	To level where decrease in width begins.	Greatest width.	Width at posterior end of old tissue.	Width at anterior end of new tissue.	Figure.
27...	Time of section.	4	—	3	—	—	3	3	3	—	1
	10 days.....	5	1.5	2.7	3	0.5	3	3	3	2.3	2
	27 days.....	6	3	2.5	3.5	1.5	1.5	2	1.7	1.3	3
	39 days.....	5.5	3	2	2.8	1.7	1	1.8	1.4	1.1	4
	64 days.....	4.3	2.5	1.3	2	1.5	0.6	1.4	1.1	1	5
	75 days.....	3.8	2.3	1.2	1.6	1.4	0.6	1.2	1	0.9	6
57...	Time of section.	9	—	3.5	5.5	3.5	3.5	3.5	3.2	—	7
	13 days.....	9.5	1.5	3.3	5.3	3	3.3	3	2.5	2	8
	25 days.....	9.5	2.7	3	4.7	3.1	3	2.5	2.1	1.9	9
	37 days.....	8.6	3.1	2.5	4.3	2.6	2.5	2.4	2	1.7	10
58...	Time of section.	10	—	2.5	5	5	2.5	2.5	2.1	—	11
	13 days.....	10.5	1.3	2.3	4	5.2	2.3	2.2	1.6	1.3	12
	25 days.....	9.8	1.8	2	3.5	4.5	2	2	1.2	1	13
	37 days.....	8.3	1.7	1.7	2.7	4	1.7	2	1.2	1	14
	61 days.....	7.7	1.5	1.5	2.4	4	1.5	1.4	1.1	1	15
	96 days.....	5	1	1.1	1.8	2.5	1.1	1.1	0.8	0.7	16
59...	Time of section.	11	—	2	4	6	2	2.3	1.8	—	17
	13 days.....	12	1	1.8	3.6	6	1.8	2	1.6	1	18
	25 days.....	12.2	1.2	1.7	3.2	6	1.7	1.7	1.5	1	19
	37 days.....	11.3	1.3	1.7	2.7	5.5	1.7	1.7	1.4	1.1	20
	61 days.....	9.6	1.3	1.5	2.5	4.8	1.5	1.5	1.2	0.9	21
	96 days.....	7.5	1	1.3	2	4	1.3	1.3	1	0.8	22
	136 days.....	5	0.7	0.9	1.4	2.7	0.9	0.9	0.75	0.6	23

each series, however, give the dimensions of the piece as they were at the time of section.

Certain of the headings of the vertical columns require brief explanation; the eighth column is headed "To level where decrease in width begins;" the anterior region of the body is the widest part

and under ordinary conditions the width of the body is uniform to about the level of the eyes; during the changes in proportion accompanying regulation the decrease in width may begin a considerable distance anterior to the eyes, hence the importance of giving this measurement. The following column "Greatest width" gives the width of this widest anterior region. The tenth and eleventh columns also require a word of explanation. The cut surface contracts after section in all cases and thus the extreme posterior end of the old tissue is more or less reduced in width. When the new tissue arises its width is the same as that of the contracted cut surface, hence the arc of the cut surface is equal to the width of the new tissue at its anterior end, the eleventh column of the table. It is desirable, however, to determine not only the width at this point, *i. e.*, the arc of the contracted cut surface, but also the width of the body just anterior to the region where it is effected by the local contraction. These measurements are given in the tenth column under the heading, "Width at posterior end of old tissue." In Fig. 2 the difference in level of the two measurements is indicated by the transverse dotted lines. As is evident from the figure the "width at the posterior end of the old tissue" is measured on the tangent to the contracted cut surface at right angles to the longitudinal axis and the width at the anterior end of the new tissue is the arc of the cut surface. As in Fig. 2, there is usually a marked difference between these two measurements except in later stages and this difference represents the contraction of the cut surface.

The last column of the table gives the number of the figure representing each stage, in order that comparison between the table and the figures may be readily made.

The intervals are not exactly the same for Series 27 as for the other series, but the difference is not sufficiently great to prevent comparison. A few data are given to supplement the figures and table.

*Series 27 (Figs. 1-6).* The level of section 4 mm. from the anterior end is indicated in Fig. 1. The short anterior piece resulting from section contains nothing but the head region and a short portion posterior to the ganglia. The margins of this part of the body are used chiefly for drawing the body forward and for the flying movements, not, like the posterior end, for holding to the substratum during locomotion. As a matter of fact this piece



was incapable before regeneration occurred of adhering to the substratum by its posterior end. It advanced by means of its cilia and alternating extensions and contractions of the antero-lateral margins of the head but its posterior end did not adhere.

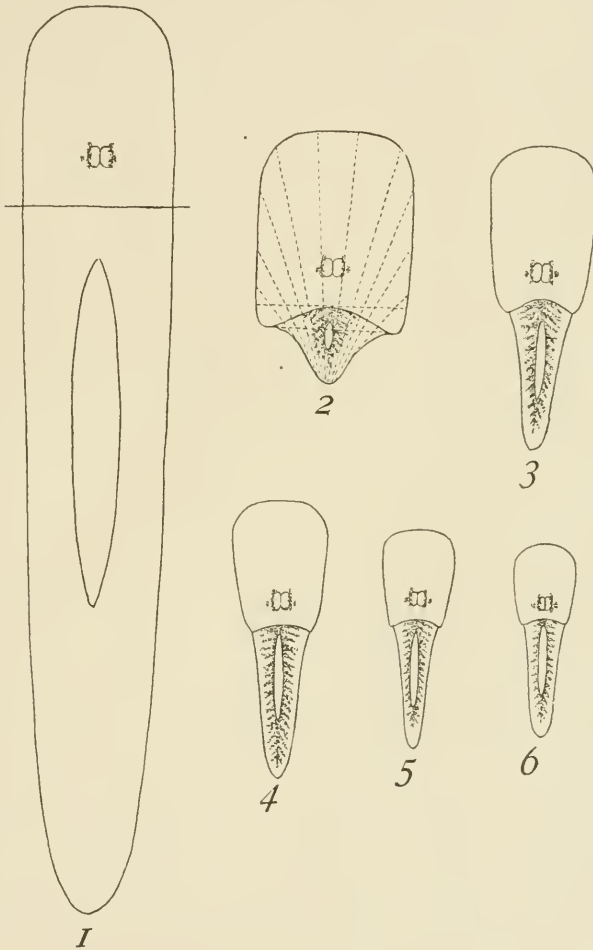

Regeneration of the posterior portion began in the usual manner from the somewhat contracted cut surface and in the course of a few days the new part began to be used for attachment as the animal advanced. The first result of this method of use was the

change in form of the new tissue from a rounded mass with convex margins to the more elongated condition with concave margins shown in Fig. 2. It is clearly evident that in this piece with short posterior end the mechanical conditions connected with locomotion are very different from those existing before section (Fig. 1). Before section this piece was continuous across the whole posterior end with the parts posterior to it, and therefore any tension to which it was subjected in consequence of attachment of the posterior parts of the animal must have been approximately parallel to the longitudinal axis.

But after the regenerating posterior portion has begun to serve as an organ of attachment (Fig. 2, two days after section) the lines of tension are no longer nearly parallel to the longitudinal axis but converge toward the posterior end (Fig. 2), this being the part most frequently used for attachment.

If the tissues of the body are at all plastic their relations must be altered to a greater or less extent by these new conditions. The effect of the tension must bring about elongation and decrease in width of the body, most marked posteriorly and decreasing toward the anterior end. And this is exactly what occurs. At the stage of Fig. 2 attachment by the posterior end has been possible only a short time and has not as yet affected any marked change in the form of the piece. In Fig. 3 (twenty-seven days), however, the form is greatly altered. Not only has reduction of size in the old part occurred but its proportions are different (see table of measurements). Its length is 25 per cent and its greatest width 33 per cent less than originally; moreover, it is now much narrower at the posterior end than at the anterior end, whereas originally its width was about the same at both ends.

The Figs. 4-6 show later stages in the process. The change of form is not great after the stage of Fig. 3, but in consequence of the more rapid reduction in size of the old part as compared with the new, some change does occur. It is of interest to note that as the piece gradually becomes smaller and less active the length of the old part decreases more rapidly than its width, *i. e.*, it becomes relatively wider (Figs. 4-6 and table). This change is always more or less evident in pieces of this kind and is exactly the reverse of what might be expected if the change in form were a "reduction to approximately normal proportions." Pieces of this kind always show a decrease in motor activity after several

weeks without food. At the stage shown in Fig. 6 (seventy-five days) the specimen was much less active than at the stage of Fig. 3. Its movements were slow and it did not adhere very closely to the substratum. The relative decrease in length of the old part is probably simply the result of the decrease in longitudinal tension accompanying decrease in motor activity. The new part does not show this change to such an extent since it is still increasing in amount, *i. e.*, relatively, at the expense of the old tissue, as is evident from the Figs. 3-6 and from the measurements of these stages in the table.

The piece died about eighty days after section.

*Series 57 (Figs. 7-10).* In this case section occurred near the middle of the body, 9 mm. from the anterior end. In consequence of contraction of the animal during section the cut was oblique on the left side (Fig. 8), but this does not affect the value of the results.

This piece included portions of the region where the margins are used for attachment, and so was able to hold to the substratum and creep in the normal manner after section and before the regenerating part became functional, *i. e.*, the regenerating posterior end was not the only posterior organ of attachment, as in the preceding series. The small protruding piece on the left side was much used for attachment even after the new tissue appeared. In consequence of the ability of the piece to attach itself by the margins and also because of the greater length of the piece the change in direction of the tension is much less than in the preceding series. It might be expected therefore that the change in form would be less rapid as well as less in amount than in the preceding series. Figs. 9 (twenty-five days) and 10 (thirty-seven days) represent later stages of the piece and it is evident that the change of proportion is relatively slight. At the stages of Figs. 8 and 9 the width of the posterior region of the old tissue is relatively less than at the time of section (see table) but in Fig. 10 the proportions are almost the same as at the time of section. Examination of the figures and measurements will show that the width at the posterior end underwent a relative decrease during earlier stages, while in later stages a relative increase appears. In other words the piece first acquired a somewhat tapering form without much reduction in length but later reduction in length brought about a return to approximately the original proportions.

The apparent change in position of the pharynx is of some interest. This is probably due on the one hand to reduction of the old anterior portion and on the other to regeneration of a

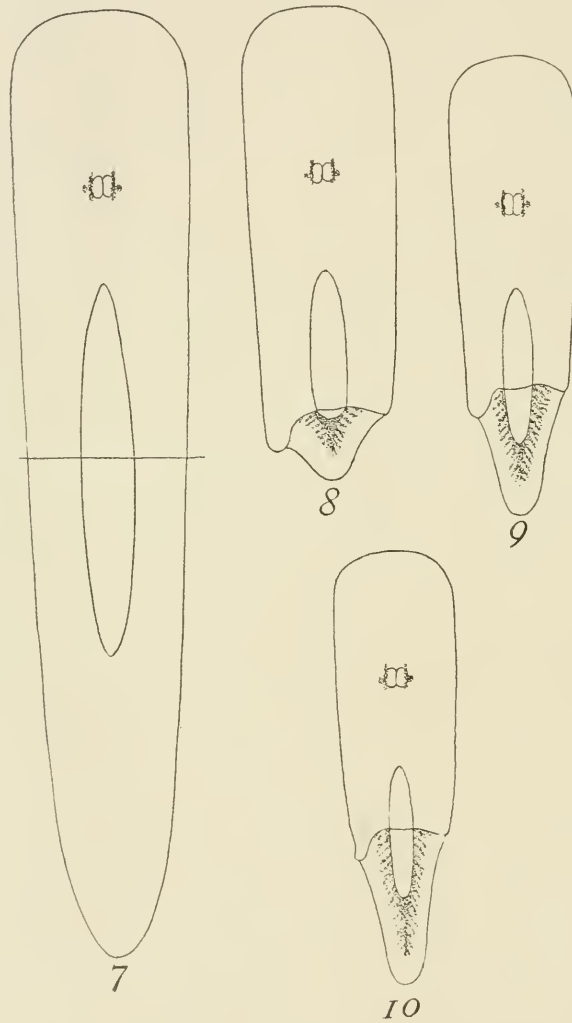

new posterior portion. That any extensive actual shifting in the position of the pharynx has occurred seems doubtful, although some degree of shifting of the internal organs within the body wall is perhaps possible.

In general the change in proportions in this piece was less marked than in other similar pieces. The relative decrease in width at the posterior end of the old part was less than usual. Possibly the tissues of this individual were less plastic than in most cases, but I think it more probable that an individual peculiarity in the activity of parts of the margin during locomotion is

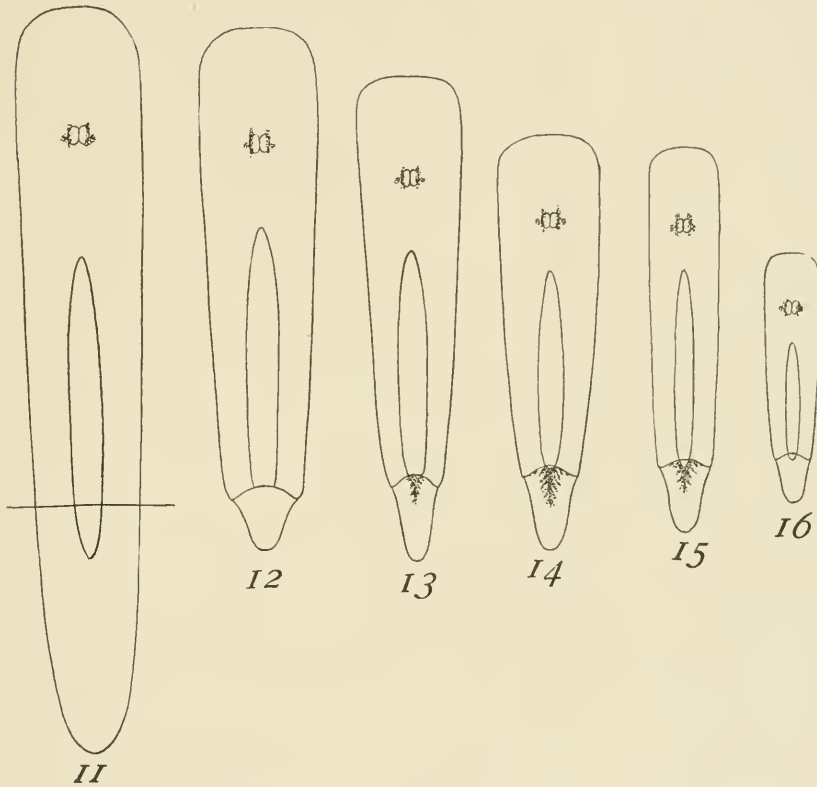

responsible. Throughout the course of the experiment it was noted that the small protruding part on the left side was very frequently and closely attached to the substratum, *i. e.*, it was used in much the same manner as a tail, doubtless a consequence of its form and relation to the substratum during movement. But the attachment of this part was usually followed or accompanied by the attachment of the other parts of the lateral margins in this region of the body on both sides. This method of use of the parts must

retard or prevent the decrease in width in this part of the body to a certain extent, hence the unusual width even in late stages (Fig. 10) of the posterior part of the old tissue. This, of course, determines the width of the new tissue at the level of the boundary between old and new. Consequently this also is wider than usual (compare Fig. 10 with Fig. 4).

This piece was accidentally killed at the stage of Fig. 10.

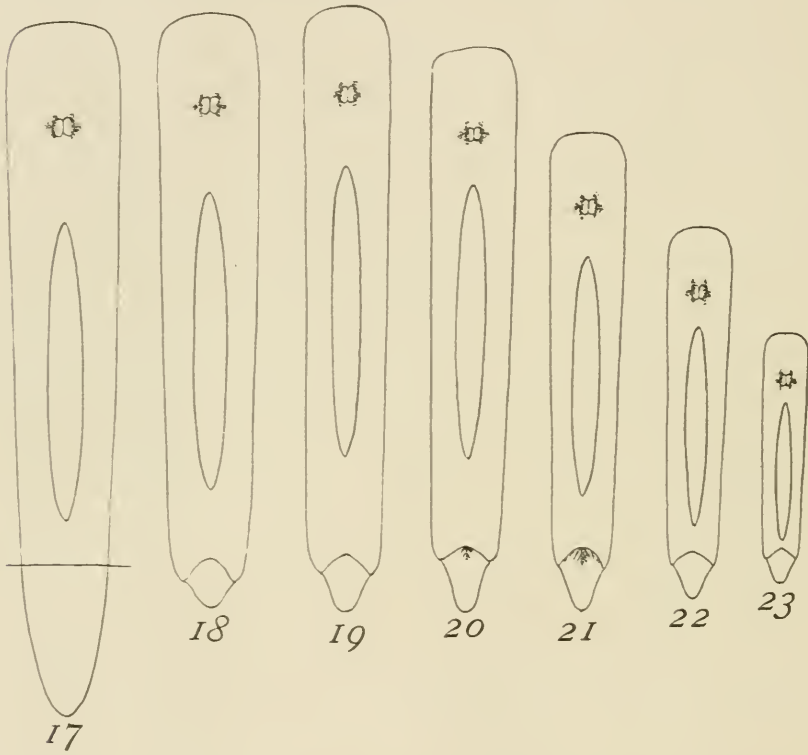

*Series 58 (Figs. 11-16).* In this series a specimen somewhat smaller than the preceding was cut transversely near the posterior end of the pharynx (Fig. 11). Figs. 12-16 show the changes in proportion which occurred, Fig. 14 is probably not quite fully extended. The decrease in width at the posterior end of the old part is marked in Figs. 12-14. Toward the end of the experiment (Figs. 15-16) the change is an almost proportional reduction in size, though with approaching exhaustion there is some relative

decrease in length. Fig. 16 represents the specimen ninety-six days after section. A few days later it died.

*Series 59 (Figs. 17-23).* The level of section in this series was some distance posterior to the posterior end of the pharynx (Fig. 17). Figs. 18-23 show the changes in form during one hundred and thirty-six days. The changes in form of the old part are relatively slight in this case as might be expected since only the posterior end is removed and the changes in the direction of tension are only slight. But a relative reduction in the width of the body in the posterior part of the old tissue does occur during the first sixty-one days of the experiment as the figures and the table show, *i. e.*, during this time the old part has become relatively longer and more tapering.

As the activity of the piece decreases during the later part of the experiment, however, a change in the reverse direction occurs: the piece becomes relatively shorter and broader until at the last stage measured (Fig. 23, 136 days after section) the posterior width of the old part is slightly greater in proportion to the length than it was at the time of section.

Circumstances made it necessary to conclude the experiment at the stage of Fig. 23, but there is no doubt that further relative decrease in length would have occurred had the piece been kept.

## 2. Discussion of the Experiments.

In all the four series of experiments described the results are similar; in each piece the old part becomes relatively longer and more slender during the earlier part of the experiment. The greatest change in all cases is in the width at the posterior end of the old part which undergoes greater reduction than the width at the anterior end, *i. e.*, the body assumes a more tapering form. These changes in proportion differ in degree according to the level at which section is made, being in general greatest in short pieces. As I have shown for *Stenostoma* (Child, '02) this is exactly what must be expected if the changes in form are the result of the changes in tension connected with locomotion. It is evident that if these changes in proportion continued the piece would finally attain proportions approximating those of the specimen from which it originated, *i. e.*, the characteristic proportions of the species. This also is to be expected if these changes are due to

mechanical factors since in the typical animal under typical conditions those factors constitute a characteristic complex.

But in all of the four cases described these changes are followed in later stages of the experiment by changes in the reverse direction: the pieces become relatively shorter and broader until in some cases the width of the body is relatively greater than before section. These "inverse" changes in proportion carry the piece farther and farther away from its original proportions. As was noted above the motor activity of the pieces decreases in marked degree long before death occurs and these changes are undoubtedly the result of the decreased longitudinal tension consequent upon the decrease in motor activity. As the tension decreases the effect of various internal physical conditions, capillarity, surface-tension, etc., becomes manifest and it may be also that a reaction to the altered conditions leads to reduction of the elongated parts, though this reduction may be in part mechanical.

The occurrence of these changes of proportion in opposite directions disposes effectually of the idea that these pieces possess some inherent capacity for assuming the characteristic proportions of the species. The piece will attain the characteristic proportions at least approximately provided the characteristic complex of conditions is present: changes in this complex result in changes in proportion and changes in the reverse direction may occur under certain conditions as I have shown.

The changes in proportion are not as rapid nor as marked as in *Stenostoma* or *Planaria* but they are similar in kind. The tissues of *Leptoplana* are much firmer than those of the other forms mentioned and are consequently less readily affected by mechanical conditions. Reverse changes in proportion have already been described for *Stenostoma* (Child, '02) and I have also found them in *Planaria* and other species.

These four series of experiments on *Leptoplana* are sufficient to illustrate the character of the changes in pieces containing the cephalic ganglia. All other experiments of the same kind—some twenty series—afforded similar results. The validity of the results can scarcely be questioned since those of each series are in a sense independent of the others. The measurements of the various stages and specimens were not tabulated and compared until long after the experiments were concluded; thus the results obtained in a given series were not influenced by the results of other experi-



ments. This fact renders the agreement between the different series all the more convincing. Moreover, the experiments show, I think, that it is not impossible to obtain fairly accurate series of measurements, even of animals so changeable in form as these.

These four series also afford some interesting data bearing upon the questions discussed in my second paper upon *Leptoplana* (Child, '04b). As regards the amount of regeneration Series 27 (Figs. 1-6) and Series 57 (Figs. 7-10) are nearly equal but in Series 58 (Figs. 11-16) the amount of regeneration is much less and in Series 59 (Figs. 17-23) still less. As regards Series 27, 58 and 59 the result agrees with the conclusion reached regarding this point in the paper above mentioned, viz: that the amount of posterior regeneration is proportional to the size of the part removed. According to this Series 58 might be expected to show less regeneration than Series 27 but as a matter of fact the amount of regeneration is greater than in any other piece among the hundreds examined. This case is an individual exception but the only one observed. At all events comparison of these pieces from different series shows that the amount of regeneration is much less when the level of section is in the posterior half than when it is in the anterior half. The bearings of this fact were discussed in the paper referred to above.

The form of the regenerated part requires only brief consideration. It is so manifestly determined in large degree by the mechanical conditions connected with locomotion that discussion is scarcely necessary. The decrease in width of the new part without corresponding increase in length which is most evident in Series 27 (Figs. 3-5) can scarcely be accounted for except as the result of longitudinal tension.

The differences in the rapidity and amount of intestinal regeneration are also well illustrated by the four series. The rapidity and amount of regeneration is greatest in Series 27 (Figs. 2-6), slightly less in Series 57 (Figs. 8-10) much less in Series 58 (Figs. 12-16) and scarcely perceptible in Series 59 (Figs. 18-23). The difference is not merely absolute and dependent upon the size of the new part but is relative, the extent of the intestine in the new tissue being relatively greatest in Series 27 and decreasing with approach of the level of section to the posterior end.

Moreover, in the later stages of Series 58 (Figs. 14-16) and Series 59 (Figs. 21-23) the intestinal branches in the new tissue

gradually disappear. The branches do not simply become invisible or difficult to see because of loss of contents but the distal portions actually disintegrate. The disintegration occurs not only in the new parts but in the old as well, though not indicated in the figures, so that in these stages only the more central parts of the intestine remain. Some consideration of these changes has been given in previous papers (Child, '04b, '04c) but other species are more favorable for experiment along this line. These cases support the suggestions reached in the other papers on *Leptoplana* regarding the effect of internal intestinal pressure on form and extent of the intestinal branches.

#### B. THE EXPERIMENTAL PRODUCTION OF ABNORMAL FORMS.

A considerable variety of abnormal forms may be produced experimentally in *Leptoplana*. Duplication of the anterior or posterior end may be obtained by the usual method, viz: partial longitudinal splitting from one end or the other. Repeated cutting of the parts is always necessary in order to obtain duplication and in most cases in spite of all precautions the parts unite, or else the repeated cutting causes the death of the specimen. Since the cephalic ganglia do not regenerate from other parts of the nervous system, duplication of the head is possible only when each part contains a considerable portion of one of the ganglia, *i. e.*, only when the cut lies very near the median plane. Tails can be produced from a cut surface facing more or less posteriorly anywhere along the lateral margin of the body provided the part can be kept from uniting with the other parts.

A full description of the various experiments is unnecessary since both method and results are similar to those described for other species of *Turbellaria*. A few of the experiments, however, are of interest and are given brief consideration.

##### 1. *Formation of a Tail Between Two Heads.*

This specimen was one of a series of ten in which the attempt was made to duplicate the head region by splitting the body from the anterior end along the median line to the pharyngeal region. Five good cases of duplication were obtained, after cutting several times, some with heads of equal size, others with one head

larger than the other. In each case where the cut separated the ganglia into halves or nearly so each half regenerated the other half and each of the two heads was similar to other cases of lateral regeneration in this region (Child, '04c). It was necessary to repeat the operation of longitudinal splitting from three to five times in order to prevent union of the two parts.

Fig. 24 shows the anterior portion of the specimen in question after the operation of splitting had been performed three times. At this stage the operation was repeated for the last time. At the next examination, a week later, it was found that the cut surfaces resulting from the last operation had united in a somewhat unusual manner (Fig. 25). The right margin of the left head overlapped the left margin of the right head. It is evident from Fig. 25 that the left margin of the right head is giving rise to an outgrowth in the posterior direction which is situated ventral to the original body; in other words, from that part of the cut surface on the right head which did not unite with the opposing surface, a tail is regenerating.

In Fig. 26 the new posterior end has elongated still further. It functions in all respects like the typical posterior end of the species. The animal uses it for attachment in creeping in the same manner as the posterior end of the main body. Since the right head is the dominant head of the specimen the functional activity of this accessory posterior end is fairly coördinated with that of the other parts of this head.

It will be noted from the figure that the right margin of the left head continues ventrally on the right margin of the new posterior end and the left margin of the right head is continuous with its left margin. The peculiar relations of this part to the other parts of the specimen make it especially interesting. It is highly probable that the attachment to the substratum of this part of the margin

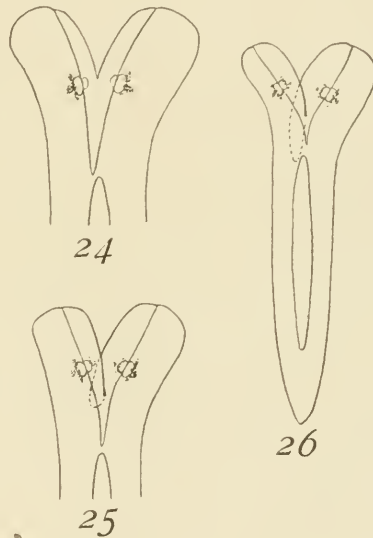

of the right head and the longitudinal tension exerted upon it are the most important factors for the formation of the tail, as was shown to be the case in *Stenostoma* (Child, '03a). It is difficult otherwise to understand why a bilaterally symmetrical posterior end should arise from the extreme lateral portion of the body. The cases of formation of supernumerary posterior ends in *Planaria* and other forms are without doubt similar in character. An account of certain experiments along this line will be given at another time.

## 2. *Experimental Duplication of the Posterior End.*

Attempts at duplication of the posterior end by partial longitudinal splitting succeed only rarely because the use of the margins and posterior ends for attachment during locomotion is such as to press the two cut surfaces closely together and union almost invariably occurs within a few days, no matter how often the operation is repeated. A few cases showing some degree of duplication of the posterior end were obtained, but one case was of special interest since it indicates the importance of the mechanical tension as a factor in the regeneration of the posterior end.

This case was one of a series of eight specimens each of which had been cut transversely through the middle of the body and then the anterior piece split longitudinally nearly to the ganglia (Fig. 27). After the first operation all the pieces united again, but after the second operation one piece was found in which the union was not complete (Fig. 28). In this piece the contraction of the longitudinal cut surfaces was so great that each half of the transverse cut surface which originally formed the posterior end of the piece had been drawn in into a position facing the median plane, *i. e.*, at right angles to its original position. In consequence of this contraction a part of the lateral margin of each half of the specimen formed the actual posterior end. The posterior portion of the specimens with the two parts separated as widely as possible is shown in Fig. 29 on a larger scale ( $\times 14$ , the other figures  $\times 7$ ). Here it is seen that the longitudinal cut surfaces have united except for a short distance at the posterior end. The originally transverse cut surfaces, though now nearly longitudinal, can be distinguished from the original longitudinal cut surfaces by their concavity and by the amount of regeneration which has taken

place upon them. From each of these cut surfaces new tissue has grown out at right angles and in much larger amount than on the longitudinal cut surfaces just anterior to these.

It should be noted that the position shown in Fig. 29 was never taken by the specimen and has been used in the figure merely to show the parts without overlapping. The position of the two posterior ends usually approached that shown in Fig. 28, though when the animal was holding tightly to the substratum the overlapping was much greater than in the figure. Most commonly during ordinary creeping the two regenerated "posterior" ends

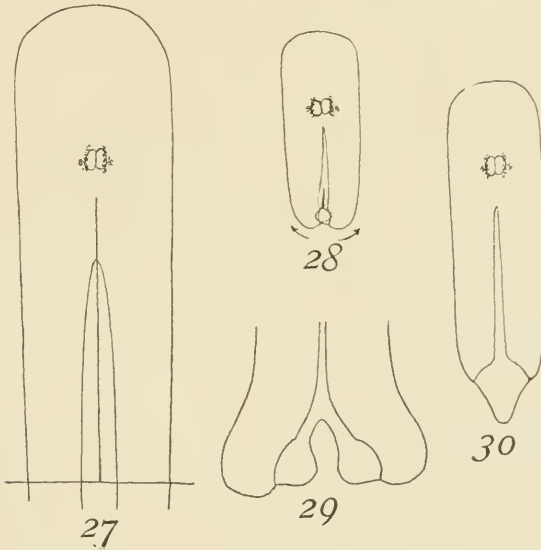

were apposed and turned dorsally so that neither of them touched the substratum. The new tissue was not much used by the specimen for attachment to the substratum, the most posterior parts of the lateral margins being employed instead. This functional substitution of the lateral margin for the posterior end is in itself interesting and determines certain other important features. The parts of the lateral margins which formed the actual posterior end of the piece reacted to contact with the substratum in much the same manner as the posterior end in normal animals. If one of the regenerated "tails" happened to be in contact with the substratum it often adhered to some extent. While the other tail

applied itself to the dorsal surface of the first (Fig. 28). But the margins of the body bent across the posterior end adhered so much more closely that the regenerating tails were not subjected to the characteristic tension. Even when one or both of the posterior ends underwent temporary contraction and the new tails were stretched the contraction took place in a curve parallel with the curved margin of each half as indicated by the direction of the arrows below Fig. 28. It is easy to see that this peculiar form of contraction follows from the course of the longitudinal muscles in the curved posterior parts.

From this description of the movements it is clear that the tension to which the regenerating tissue on the originally posterior surfaces is subjected is slight compared with that in the typical case of posterior regeneration. The incurved lateral margins of the old part perform the function which in typical cases is performed by the new tissue on the posterior cut surface. And secondly, since all muscular contraction of these posterior ends follows the curve indicated by the arrows in Fig. 28 it is clear that any tension to which the new tissue may be subjected in consequence of attachment during such contraction is approximately perpendicular to the cut surfaces. Attachment of one of the new tails was sometimes observed under these conditions and actual stretching perpendicular to the cut surface was visible.

If we compare the amount of regeneration in this specimen with that in other pieces in which the cut surfaces had united we find that there is a marked difference. Figs. 28 and 30, both drawn to the same scale, represent two pieces of the same series at the same time after the operations. In the case shown in Fig. 30 the cut surfaces united fully, and the new tissue was subjected to the typical longitudinal tension and posterior regeneration occurred in the typical manner and amount. In the other case the new tissue on the (originally) posterior cut surfaces could not be used in the typical manner, hence was subjected to slight tension only. The amount of regeneration in this case is only a small fraction of the amount in Fig. 30. This case constitutes almost an experimental demonstration of the correctness of the conclusions reached in previous papers (Child, '04b, '04c), viz: that the mechanical conditions are important factors in determining the amount of regeneration.

Another feature of importance in this case is the direction of regeneration from the posterior cut surfaces. On each side the

new tissue grows out perpendicularly to the cut surface, *i. e.*, at right angles to the longitudinal axis of the body when the parts are in their usual position (Fig. 28). In my first paper on *Leptoplana* (Child, '04a) I showed that the direction of outgrowth of new tissue was determined, at least in part, by the direction of the mechanical tension to which it was subjected. As regards the present case it was pointed out above that when these outgrowths of new tissue are subjected to tension it is approximately perpendicular to the cut surface. Thus, in this case the direction of the outgrowth is determined by the direction of the tension to which it is subjected. If the specimen were capable of holding the two ends in the position indicated in Fig. 29 and if the new tissue were much used for attachment there is little doubt that each outgrowth would soon become oblique with respect to the surface from which it arose and approximately parallel to the longitudinal axis of the body. But in the case under consideration the functional substitution of the margins of the old part for the tail became more and more complete as time went on. The animal seemed to become more and more accustomed to the altered positions of parts and coördination apparently became more perfect. The form and relative size of the new parts did not change appreciably from the condition represented in Fig. 28.

This case, like others described in previous papers, indicates how readily the course of regulation may be altered when the really essential conditions are changed. It also shows very clearly that the power of a piece to attain the characteristic form of the species is dependent upon characteristic functional activity.

Repeated attempts to obtain other specimens of the same sort were unsuccessful. Usually the contraction of the cut surfaces was not sufficient to bring the transverse surface into line with the longitudinal.

### 3. *Duplication of the Posterior End by Protrusion of the Pharynx from the Cut Surface.*

Like the preceding, this case is interesting, not merely as an abnormality, but as adding to the evidence regarding the factors concerned in the growth of new parts.

The individual, a worm of average size, was cut transversely through the anterior end of the pharynx leaving only a small part

of the old pharynx in the anterior piece (Fig. 31). Six days after section the anterior piece presented the appearance of Fig. 32. The regenerating posterior region was incompletely divided into two parts by the mass of pharyngeal tissue that protruded in the median line. It will be observed that the separation of the two tails is much more complete ventrally than dorsally. On the dorsal side a thin membrane joins them back almost to the tip of the protruding pharyngeal mass, while on the ventral surface they are distinct to the level of the old tissue. Fig. 33 is an enlarged diagram showing the conditions at the level of the dotted line in Fig. 32. The stippled mass in the middle represents the old pharyngeal tissue, on each side the portions of the tails in contact

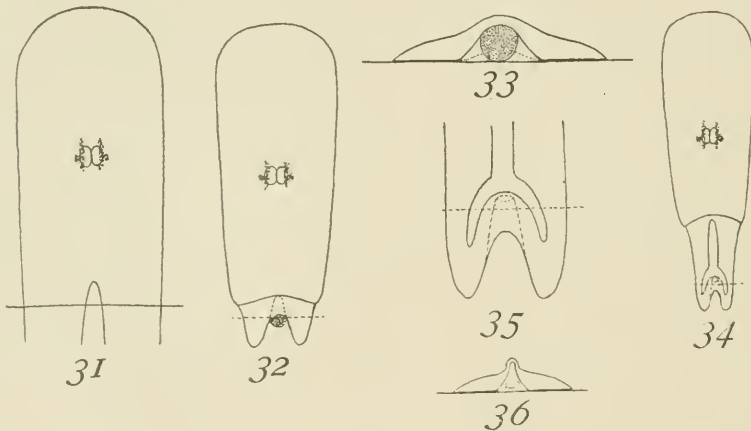

with the substratum are indicated and continuous with these is the thin membrane dorsal to the old pharynx.

A few days later the old pharyngeal tissue dropped off, but the walls of the old pharyngeal pouch had already united with the body-wall so that when the pharynx fell away an opening facing postero-ventrally remained.

The condition of the piece twenty-one days after section is shown in Fig. 34. The regenerating posterior region has elongated considerably and only its posterior third is double. The regenerated pharynx, like the body, is duplicated posteriorly. The relations of parts are more clearly shown in the enlarged diagrams 35 and 36. In Fig. 35, a dorsal view, it is seen that union between



the two tails extends further posteriorly on the dorsal side than on the ventral; the region between the two longitudinal dotted lines in Fig. 35 is not in contact with the substratum as the animal creeps and at the anterior end of this space between the two tails the opening still persists.

Fig. 36 is similar to Fig. 33 and indicates the relations of parts in the dorso-ventral plane at the level of the transverse dotted line in Fig. 35. The two tails are less widely separated than in earlier stages, hence the thin membrane between them is thrown into a dorsal fold as indicated in the figure.

The postero-ventral opening in the space between the two tails was apparently connected with the pharyngeal pouch of the new pharynx and may therefore be regarded as a mouth. In the living animal I was unable to find any other mouth on the ventral surface.

It was my intention to keep the specimen alive as long as possible in order to determine whether this duplication was gradually obliterated and then to fix the piece and study by means of sections. During the six weeks following the stage shown in Fig. 34 no marked changes except reduction in size occurred. At the end of this time the piece was lost. It is evident that the protrusion of the mass of old pharyngeal tissue from the cut surface was the condition which originally determined duplication of the end. If this be admitted several questions arise at once. Of these we may consider first why the region dorsal to the old pharynx does not regenerate as rapidly as the regions lateral to it. The protrusion of the old pharynx in a postero-ventral direction offers no obstacle to growth in the posterior direction of the parts dorsal to it. Evidently the dorsal region does regenerate, for the thin membrane uniting the two tails dorsal to the pharynx represents the regeneration from this region. But regeneration here is less rapid than in the regions lateral to the pharynx so that duplication appears dorsally as well as ventrally, though to a less extent.

The factors which have served in so many other cases, viz: attachment to the substratum and tension consequent upon locomotion are in my opinion the chief factors concerned here. It is evident that the protrusion of the mass of pharyngeal tissue in the postero-ventral direction prevents the new tissue which arises dorsal to it from coming into contact with the substratum. This

was clearly seen to be the case by observation of the specimen during movement. Only the regions lateral to the pharynx could be used in the characteristic manner. The result of the duplication in the complex of functional conditions is the duplication in structure. The thin membrane dorsal to the pharynx elongates only as the tension exerted upon the two tails is transferred to it and so remains behind these parts in growth.

But it may appear at first glance that the loss of the old pharynx a few days later alters conditions and that after this there is nothing to prevent the median region from coming into contact with the substratum and elongating as rapidly as other parts. This is not the case, however, for as long as the two tails are used in the typical manner (Figs. 34 and 35) the median connecting region cannot come into contact with the substratum but must remain as a dorsal fold (Fig. 36). Indeed the fold is frequently more marked than before the loss of the old pharynx since the two tails often lie nearer together than was possible when they were separated by the old pharynx. Thus, even after the loss of the old pharyngeal tissue the median region is subjected to tension only as the lateral parts are strongly stretched and so maintains the relations with other parts which were originally determined by the presence of the mass of pharyngeal tissue.

Incidentally this case shows very clearly that the terminal portions are formed first in the regeneration of the posterior end. The postero-ventral "mouth" between the two tails which was at first situated at the level of the cut surface is carried posteriorly as regeneration occurs and at the stage of Fig. 34 lies far behind the cut surface. Occasionally when the animal drew back suddenly from some object which its head had touched the two tails became more or less extended laterally each forming an angle of about  $45^\circ$  with the longitudinal axis. Under these conditions the median region was sometimes in contact with the substratum, but since this position was not often taken and was never maintained for more than a short time no appreciable effect could be expected.

This case is interesting chiefly because it constitutes valuable evidence in favor of the view that the functional conditions and among them the tension to which parts are subjected are important "formative" factors.

## D. REGULATION AND EMBRYONIC DEVELOPMENT.

The problem of regulation must be regarded as a part of the problem of development; indeed, as has already been abundantly demonstrated the investigation of regulatory phenomena and processes is of fundamental importance as a means of throwing light upon the problems of embryonic development. On the other hand the phenomena of regulation and of ontogeny are in certain respects so different that caution is always necessary in extending conclusions from the one field to the other.

Probably the most important field of investigation in connection with regulatory phenomena is the determination by experimental methods of the conditions and processes of morphogenesis. Exact knowledge of these conditions and processes is of fundamental importance in biology, not only directly as an addition to the data of science but indirectly as well, since it affords the only means by which we can ever hope to attack intelligently certain other problems, such for example as those of heredity and evolution. It is clearly impossible to obtain any intelligent conception regarding the nature of the germ cells before we have determined the relation between the adult organism and the cells from which it arises. It is scarcely too much to say that the only satisfactory method of determining what is inherited is the method of elimination: at any rate if we can determine experimentally what is not inherited we shall be in a far better position to discuss the nature of inheritance. Objection to these statements may be made on the ground that it is possible to determine by direct experiment, *i. e.*, by hybridization or other forms of breeding, that certain "characters," *e. g.*, a color or a structural feature are inherited in certain cases. Such an objection rests, however, on a total misunderstanding of my position. The point I wish to make is that the color or the structure is not itself inherited, but only an unknown something that can give rise to the one or the other under certain conditions. This is of course familiar to all, yet it seems to be forgotten again and again. Qualities, relations, and reactive capacities of protoplasm not "characters" are inherited. Theories of heredity which regard the germ cell as containing a multitude of elements, each representing some character or group of characters in the developed organism are the monstrous offspring of a morphology divorced from physiology

and can serve only to delay the advance of biology. Exact experimental data concerning the physiology of development constitute the most effective weapons for combating and overcoming errors of this kind. Within the last few years they have been forced repeatedly to retire from one defense to another.

But there is evident in much of the work of recent years upon developmental physiology a certain inclination to regard the problems of morphogenesis as at present insoluble. This manifests itself in Driesch's later work in the form of a vitalistic or "autonomistic" hypothesis based on certain phenomena of form-regulation, another interesting though perhaps logical consequence of the separation of morphology and physiology. As I have shown in several papers (Child, '02, '03, '04a, '04b) certain of the phenomena of regulation which appear so mysterious to Driesch and others are so only because they are wrongly interpreted. Others, like Morgan, who are less extreme hold that while the problem of morphogenesis is fundamentally a physico-chemical problem yet it is at present and perhaps will always be insoluble.

These views undoubtedly take their origin from the morphological conception of life, the belief that the essential feature of organic development is the production of structure. When we cease to consider "the tendency to return to normal proportions," "form-entelechies" and other similar and fundamentally morphological abstractions, and regard the organism as a complex functioning in a characteristic manner morphogenesis appears as one of the results of this functional activity of the complex. The term function is used here to include all the activities of the organism, all transference and transformation of energy. Undoubtedly qualitative differences must exist as a basis for complex function. The point of importance is that the organism is primarily a functional rather than a morphological complex. It is the qualities, *i. e.*, the capacities for functional activity that are transmitted from individual to individual and from period to period. The form of the organism is in general the result of its own activity under characteristic external and internal conditions.

Roux has recognized two stages in development, an organ-forming and a functional stage. During the first period the various organs develop without "functional" activity, while during the second increasing "functional" activity and interdependence

appear. In other words, during the first period the machine is constructed and during the second it functions. Here again the morphological conception of development appears as the basis of this analysis. In my opinion, all stages of development are to be regarded as functional though the kind of function and its visible results differ.

It is important, moreover, to distinguish between the visible substances or those which future investigation may prove to exist in the nucleus or cytoplasm of the germ-cell and the structures into which they develop. Suppose a certain substance or region of the egg can be followed to the entoderm of the larva. It is not conceivable that this substance or region if isolated can form a typical intestine, although its cells may differentiate into typical intestinal cells. In other words this region may continue to function in the characteristic manner after isolation, and each of its cell units may undergo the differentiation corresponding to this function, but the typical form of the whole does not appear because the typical relations of the elements to each other, and to the environment are not established. The differentiation of the cell units is doubtless in large part the result of their chemical constitution while the formation of a characteristic organ, the intestine, is largely the result of physical factors, the natural pressures and movements of cells, surface tensions, tensions due to conditions in other parts, pressure of fluids, etc. Development of the typical *form* is due to these conditions as well as to the character of the substance itself. And these conditions have been ignored to a large extent in the study of development.

Morphogenesis is very commonly regarded as the result of the composition of the substances in the germ-cell. From this point of view have arisen the hypotheses which regard morphogenesis as analogous to crystallization, and the theories of formative stuffs which, though perhaps correct for certain elements of structure, are, nevertheless, without general significance because they are based on inadequate conceptions.

The relation between the composition of the germ-cell and the structure of the developed organism cannot be a direct one, but is rather exceedingly remote. To look for the equivalents of morphological characters in the germ-cell must involve us in many difficulties, because most so-called morphological characters are primarily typical space-relations of masses and these necessarily

differ from anything in the germ-cell. When, however, we consider the matter from the physiological side we can trace a certain relation between the cell and the fully formed organism; both exhibit characteristic functional activities and frequently we can trace a given functional complex from the cell through ontogeny by its effect upon organization. This, I think, is the real significance of His' "organbildende Keimbezirke" and Wilson's ('04) formative substances in the egg-cytoplasm. But the designation of these regions as formative regions or substances is a morphological mode of expression which seems to me misleading. All living complexes are formative, or may be under proper conditions; but they are formative because they are functional. Let us consider briefly a case in point, viz: the typical form of the posterior end in *Leptoplana* or *Stenostoma*. This is a characteristic of the species, yet I have shown that it depends largely upon mechanical conditions of tension for its formation. The tension is the result of typical activity on tissues of a typical physical quality in a typical environment. The typical activity depends again on a typical constitution, and so on. What is transmitted from the previous generation? Certainly not tail-germs, nor tail-forming substances, nor anything that is directly related to the tail of the adult. In this case the "tail" is primarily a physical arrangement of material resulting from a characteristic complex of physical and other conditions. In other cases the analysis may proceed on widely different lines but the result must be similar.

I believe it can be shown that morphological conceptions of development are all anthropomorphic in character and related to our conceptions of man-made structures composed by adding element to element. It becomes more and more evident as our knowledge increases that these conceptions must be discarded. But we cannot as yet substitute for them any adequate conception; we can compare life to nothing but itself. It is perfectly evident that with the physics and chemistry of the past and present we can never hope to interpret the phenomena of life, but we are entering on a period which promises that our physical and chemical conceptions will be as profoundly transformed by increasing knowledge of the processes of living organisms as our conceptions of life ever were by the adoption of physico-chemical hypotheses.

The phenomena of regulation in the broadest sense constitute at present one of the most important and promising fields for work. Within the last few years many of our conceptions regarding development have been profoundly modified by the results of experimental work along these lines and there can be little doubt that they are destined to still greater modification. Whatever modifies our theories of development must alter our ideas regarding inheritance and the nature of the germ-cell, both problems which are receiving much attention from morphologists. The physiological investigation of development will probably afford in future far more numerous and exact data regarding the nature of inheritance and other fundamental problems of biology than any other field of research. The phenomena of regulation differ from those of embryonic development as the conditions differ in the two cases. Many parts of the field are accessible even at present to experimental methods and there can be no doubt that in future it will be possible to extend control of them much farther.

Roux ('95) maintains, however, that two distinct categories of development "typical" and "regulatory" must be recognized and that the mechanisms concerned in the formation of a given structure in typical development may be different from those which come into play in regulation. Hypotheses of this kind only increase instead of diminish our difficulties and, moreover, they are based on theoretical considerations and not on observation and experiment. If we admit instead that form and structure are results of reactions to conditions it is evident that changed conditions may change both the processes and the results. Regeneration of a part removed may differ widely from the ontogenetic development of the same part, but, as I have attempted to show in this and preceding papers on *Leptoplana* (Child, '04a, '04b, '04c) the conditions to which the regenerating tissue is subjected are different from those to which the part is subjected in ontogeny; in the one case the tissue arising from the cut surface is connected with a fully developed part, in the other all parts are developing together. It is to be expected therefore that the course of regeneration will be briefer than that of ontogeny and, moreover, that it will differ in various respects, according as particular conditions differ. Notwithstanding these differences, indeed often because of them, the phenomena of regeneration are of great importance in the physiology of development. But other methods of regulation

occur, one of the most important being what Driesch ('01) has designated as redifferentiation. I think it probable that in many cases the so-called "redifferentiation" when subjected to a closer study will turn out to be merely differentiation. Cases of this sort in which the formation of new tissue is involved, such for example as the formation of the new pharynx in the old tissue in Planaria, differ from regeneration proper, *i. e.*, the outgrowth of new tissue from the cut surface, chiefly in that growth is not localized at the cut surface but is distributed through a larger or smaller portion of the old tissue. But why should the new growth be localized in the one case and not in the other? In attempting to answer this question it is necessary to anticipate somewhat and state certain conclusions from my experiments for which the data have not yet been fully given. These will serve merely as suggestions to make clear my point of view. In cases where regeneration, *i. e.*, outgrowth from the cut surface, takes place it will be found that the old part remains essentially a part as regards function; functional substitution for the part removed does not occur. But when proliferation at the cut surface begins as the direct result of the altered conditions the functional conditions to which this region is subjected are more or less similar to those characteristic of the part removed and growth, *i. e.*, regeneration of this region and its differentiation into a part more or less like that removed occur. If, on the other hand, the old part is capable of performing more or less perfectly the functions of the part removed, that is to say, if its reactions are modified by the changed conditions so as to resemble those of the part removed, corresponding changes will occur in the structure of that portion which resembles functionally the part removed and it will be "redifferentiated" into a part like that removed. As an example let us compare the case of Leptoplana (Child, '04a, '04b, '04c) with that of Stenostoma (Child, '02, '03). Regulation after removal of the posterior end in Leptoplana is wholly or almost wholly regeneration, *i. e.*, growth from the cut surface, while in Stenostoma the posterior region of the old part "redifferentiates" into the new tail. When we compare the behavior of the pieces after removal of the posterior end, we find that in Leptoplana functional substitution of the posterior end of the piece for the original posterior end does not occur or occurs only in slight degree, while in Stenostoma the posterior end of the piece functions almost perfectly as a tail. This brief comparison



is perhaps sufficient to illustrate the point. I believe that the absence or occurrence of functional substitution of other parts for a part removed are important conditions determining whether regeneration or "redifferentiation" shall occur.

In certain cases of regulation, as for example one form of regulation occurring in *Clavellina* (Driesch, '02) the old structure disappears more or less completely and the piece seems to return to the embryonic condition. Out of this apparently undifferentiated mass a new complete individual arises by processes more or less similar to those of ontogenetic differentiation. This is apparently a case of true redifferentiation. Our knowledge of cases of this sort is very incomplete as yet; we do not even know exactly to what extent the old structure disappears, but it is evident that we have here something widely different from regeneration and approaching more closely to embryonic development. In the first place, according to my point of view, the disappearance of the original structure of the piece is only incidentally a part of the regulative process; the old structure disappears simply because the conditions which maintained it are no longer present. The previous differentiation has not destroyed the capacity of the tissues for reacting to altered conditions and the first effect of this altered reaction is the disappearance of the old structure. The transformation of the part into a "whole" is probably identical with the loss of the specification which resulted from the particular conditions to which it was subjected; it is thus a negative rather than a positive change, the loss of visible differentiation rather than the acquisition of new potentialities. The development of the new individual from the undifferentiated mass occurs in much the same manner as in typical ontogeny. The different origin of the cell-mass in the two cases does not constitute a fundamental difference, though it may be found to determine some differences in detail.

From what has been said it follows that the greater the degree of differentiation, or in other words the greater the specialization of conditions in different parts of the organism, the greater will be the difference in the parts and the less the capacity for altering the reactions in correspondence with altered conditions. Hence we may expect "redifferentiation" to occur only in relatively simple forms while regeneration, or destruction of other parts followed by regeneration, or finally destruction without regeneration may follow removal of a part in more complex forms.

## SUMMARY.

1. During regulation typical changes in proportion of the old parts occur, consisting in a relative decrease in width and increase in length of the body. These changes in proportion are greatest in the posterior region of the piece involved and are greater in short than in long pieces. In cases where a marked decrease in motor activity occurs, as for example during the later stages of regulation of pieces without food, changes of proportion in the reverse direction occur.

2. These changes in proportion are primarily due to mechanical factors. The relative elongation and decrease in width are largely the result of the tension consequent upon the use of the regenerating posterior end as an organ of attachment during locomotion. The change in direction of the tension differs according to the length of the piece, being greatest in short pieces.

The reverse changes in proportion are the result of marked reduction in the longitudinal tensions consequent upon a decrease in motor activity. Under these conditions the piece approaches more or less a rounded form in consequence of internal pressures, surface tension, capillarity, etc.

3. Certain cases of experimental duplication of the anterior or posterior end afford strong evidence in favor of the view that the direction and amount of posterior regeneration and the form of the regenerated part are determined in large degree by the functional conditions connected with motor activity, the mechanical tension being probably the chief factor.

4. The experimental analysis of regulative phenomena constitutes one of the most effective methods of attacking the problem of morphogenesis and affords valuable data for the problems of heredity. The results of this field of work indicate that physiological conceptions and hypotheses must be substituted for morphological.

Hull Zoölogical Laboratory,  
University of Chicago.

May, 1904.

## BIBLIOGRAPHY.

- CHILD, C. M., '02.—Studies on Regulation. I. Fission and Regulation in Stenostoma. Arch. f. Entwicklungsmech., Bd. xv, 2 and 3 H., 1902.
- '03.—Studies on Regulation. II. Experimental Control of Form-Regulation in Zooids and Pieces of Stenostoma. Arch. f. Entwicklungsmech., Bd. xv, 4 H., 1903.
- '03b.—Studies on Regulation. III. Regulative Destruction of Zooids and Parts of Zooids in Stenostoma. Arch. f. Entwicklungsmech., Bd. xvii, 1 H., 1903.
- '04a.—Studies on Regulation. IV. Some Experimental Modifications of Form-Regulation in Leptoplana. Journ. of Exper. Zoöl., vol. i, No. 1, 1904.
- '04b.—Studies on Regulation. V. The Relation between the Central Nervous System and Regeneration in Leptoplana; Posterior Regeneration. Journ. of Exper. Zoöl., vol. i, No. 3, 1904.
- '04c.—Studies on Regulation. VI. The Relation between the Central Nervous System and Regeneration in Leptoplana; Anterior and Lateral Regeneration. Journ. of Exper. Zoöl., vol. i, No. 4, 1904.
- DRIESCH, H., '01.—Die Organischen Regulationen. Leipzig, 1901.
- MORGAN, T. H., '99.—Regeneration in the Hydromedusa *Gonionemus vertens*. Amer. Nat., vol. xxxiii, 1899.
- '00.—Regeneration in Planarians. Archiv. f. Entwicklungsmech., Bd. x, 1900.
- ROUX, W., '95.—Gesammelte Abhandlungen. Leipzig, 1895.
- WILSON, E. B., '04.—Experimental Studies in Germinal Localization. I. The Germ-Regions in the Egg of Dentalium. Journ. of Exper. Zoöl., vol. i, No. 1, 1904.



# THE FORMATION OF CENTROSOMES IN ENUCLEATED EGG-FRAGMENTS.<sup>1</sup>

BY

NAOHIDÉ YATSU.

WITH 8 FIGURES

I. Introduction .....	287
II. Solutions and Precautions Against Accidental Fertilization .....	289
III. Experiments on the Egg at the Metaphase of the First Maturation Mitosis .....	291
A. Enucleated Fragments Treated with CaCl <sub>2</sub> Solution, Heat-sterilization .....	291
a. Methods .....	291
b. Cytasters Studied in Life .....	291
c. Cytasters Studied in Sections .....	293
d. Nature of the Central Granules, and Development of the Cytasters .....	299
B. Enucleated Fragments Treated with CaCl <sub>2</sub> Solution, Time-sterilization .....	301
C. Enucleated Fragments Treated with MgCl <sub>2</sub> Solution, Heat-sterilization .....	301
IV. Experiments on the Egg before the Dissolution of the Germinal Vesicle; CaCl <sub>2</sub> Solution, Heat-sterilization .....	303
V. Review of Literature .....	304
VI. Conclusions .....	308
VII. Summary .....	310
VIII. Literature .....	311

## I. INTRODUCTION.

Whether or not an aster containing a centrosome (centriole) may arise in the egg-cytoplasm independent of preëxisting centers is a cytological problem of high interest. This seemingly difficult question may be decided by a simple experiment. If we are able to produce an aster with the centriole in an egg-fragment containing no preëxisting centrioles, we cannot escape the conclusion that these structures may be formed *de novo* in the egg-cytoplasm.<sup>2</sup>

<sup>1</sup>The main part of the present paper was carried on in the summer of 1904 under a grant from the Carnegie Institution, to which I wish to express my sincere thanks. To Prof. E. B. Wilson I acknowledge my great indebtedness for his kindly advice and criticism during the progress of this work. I am also under obligation to Prof. J. S. Kingsley, Director of the Harpswell Laboratory, for his kindness extended to me in many ways during my stay at his laboratory.

<sup>2</sup>The presence or absence of the centrosome, *i. e.*, the larger body surrounding the central granule or centriole, need not concern us here; for according to the latest work (for example, of Vejdovský and Mrázek, Meves, Bouin), the centrosome is a periodical accumulation of the special substance, centrosplasm, around the centriole, which alone can be considered as a constant and autonomous structure.

This method of examining the problem was first employed by Wilson in 1901 by shaking to pieces the unfertilized eggs of *Toxopneustes* and treating the enucleated fragments thus obtained with  $MgCl_2$  solution. He found, upon studying the living fragments, that not only do asters appear in such fragments, but also that some of them have the power of division like the normal asters. In sections he observed that the asters thus formed contain in some cases the centriole. He, therefore, drew the conclusion that these centrioles must have been formed *de novo*. Subsequently Meves and Wassilieff almost simultaneously raised objections against Wilson's method and cast doubt upon his results on a priori ground. Meves thinks that by shaking the egg center may be thrown out into the cytoplasm, while Wassilieff takes the view that shaking may bring about the flowing out of the nuclear fluid from the egg-nucleus. To meet these criticisms Professor Wilson suggested to me in February, 1903, to carry out similar experiments on enucleated fragments obtained by cutting eggs individually. In the summer of 1903 I made series of experiments at the Harpswell Laboratory on the eggs of *Cerebratulus lacteus* and obtained clear evidence that cytasters do appear in such fragments, provided the egg be cut after the first maturation figure is formed (which in this egg occurs before fertilization); no cytasters are found, however, if the operation be performed before the germinal vesicle has faded. I tried similar experiments on the egg of *Echinarachnius parma* and found that here cytasters arise in enucleated fragments from the matured egg. In the meantime Petrunkevitch independently attacked the same problem in enucleated fragments obtained both by shaking and by cutting the eggs singly. In none of the fragments did he find asters containing a centrosome. He was, therefore, led to the conclusion that in the whole eggs the centrosomes in the cytasters are the division products of the egg center. The obvious inadequacy of his evidence has been pointed out by Wilson in a brief rejoinder ('04).<sup>1</sup>

In 1904 I undertook a repetition and extension of the experiments of the previous year during my stay at the Harpswell Laboratory, confining my attention to the egg of *Cerebratulus lacteus*. Fortunately I obtained very consistent and constant

<sup>1</sup>A more detailed historical review of literature I shall take up later on (see p. 304, *et seq.*)

results; in fact, cytasters appeared in almost all cases. In sections of the enucleated fragments, in which asters were produced, I found that *in all the cytasters the centrioles were present.*

The egg of *Cerebratulus* is better suited to our present purpose than that of sea-urchin. The egg, when removed, has a large germinal vesicle. In some twenty minutes the nuclear membrane fades away, and in an hour or so the egg being still unfertilized, the first maturation mitosis reaches the metaphase. The mitosis, however, does not proceed beyond this stage, unless fertilization takes place.<sup>1</sup> One can, therefore, in the nemertine egg trace the progressive changes of condition in the cytoplasm from the primary oöcyte onward. Moreover, the asters of *Cerebratulus* have very well defined centrioles, which seem to have, even in the division stages, far greater power to resist the action of various fixing fluids than those of the sea-urchin egg.

To avoid confusion I shall follow strictly Boveri's definitions of centriole, centrosome and centroplasm, using the term "aster" for the whole structure including the ray system, archiplasm, centroplasm and centriole. The aster without the centriole (if such aster exist) I shall call "pseudaster" (= Boveri's pseudosphere). In accordance with Wilson I use the term "cytaster" for an aster or pseudaster which is unconnected with nuclear matter.

## II. SOLUTIONS AND PRECAUTIONS AGAINST ACCIDENTAL FERTILIZATION.

The means of producing cytasters that were tried were: shaking, ether,  $MgCl_2$ ,  $CaCl_2$ ,  $KCl$ , and  $NaCl$ . Of these the first two did not cause any perceptible change on the eggs, while the other four modified mitoses and produced the cytasters in various degrees. The following solution of  $CaCl_2$  proved best of all; it was, therefore, used almost exclusively for the experiments on enucleated fragments:

<sup>1</sup>I did not succeed in producing the normal polar bodies artificially. Although, as a matter of fact, in a small percentage of the  $CaCl_2$  eggs and the  $CaCl_2+KCl$  eggs (the latter being Professor Wilson's material) one or two polar bodies were extruded, yet in these cases the mode of maturation was so abnormal that it was thought undesirable to use the eggs thus matured for other purposes.

55 per cent sol. of $\text{CaCl}_2$ (= 5 m. $\text{CaCl}_2$ ) <sup>1</sup> .....	1 part.
Sea-water .....	9 parts.

The two solutions found to be the next best were:

14.6 per cent of $\text{NaCl}$ (= $\frac{20}{8}$ m. $\text{NaCl}$ ).....	1 part.
Sea-water .....	2 parts.
18.6 per cent of $\text{KCl}$ (= $\frac{20}{3}$ m. $\text{KCl}$ ).....	1 part.
Sea-water .....	2 parts.

It may be stated that there are only slight differences in action of these three solutions, while that of  $\text{MgCl}_2$  solution is totally different from the others.

The precautions taken against accidental contamination of the eggs with spermatozoa were as follows: Sea-water was first heated to  $80^\circ \text{C}$ . for twenty minutes, cooled down to the original temperature ( $20^\circ \text{C}$ .) and well-water was added to make up the loss by evaporation. The bottle containing the water thus sterilized was aerated by violent shaking. The female worms were kept for two days in an aquarium separate from the males. To obtain the eggs for experiment a piece about an inch long was cut out of a ripe female with a pair of sterilized scissors and was submerged in fresh water for five minutes. After that the piece was washed with sterilized sea-water to get rid of the eggs, which had been squeezed out in fresh water, since the eggs thus discharged might have undergone some pathological changes. The piece thus treated was chopped up with a pair of scissors sterilized with fresh water. Of course, all the dishes used for experiment were washed with fresh water.

For each experiment with the cytasters two lots of eggs from the same piece were used as controls to see if the particular lots of eggs were healthy.

A. One lot of eggs was examined after five hours' sojourn in the sterilized sea-water. Most of them were at the metaphase of the first maturation mitosis, while in a few eggs the germinal vesicle was found intact.

B. The other lot of eggs was mixed with sperm-water ten minutes after release. Fertilization and subsequent development took place normally as in those eggs kept in ordinary sea-water.

<sup>1</sup>Dry crystals dissolved in well water.



## III. EXPERIMENTS ON THE EGG AT THE METAPHASE OF THE FIRST MATURATION MITOSIS.

A. *Enucleated Fragments Treated with the CaCl<sub>2</sub> Solution Heat-Sterilization.*

a. *Methods.* The eggs were released in the sterilized sea-water, the precautions already stated being taken. After an hour and half the operation was begun. Had the eggs been fertilized they would have reached the two or four-cell stage by that time. As a matter of fact, none went beyond the metaphase of the first maturation mitosis. The eggs were cut singly into two with a lancet known as Jaeger's straight keratomy knife. Both the nucleated fragment (*i. e.*, the one containing the mitotic figure) and enucleated one were put for five minutes in separate dishes with the sterilized sea-water so as to give them time to round up, since sudden contact of fresh cut surface with a salt solution seemed injurious. The enucleated fragments were examined and drawn. Then they were transferred into the solution of CaCl<sub>2</sub> prepared with the sterilized sea-water. (See p. 290.) In it they were kept for an hour or sometimes a little longer. (This length of time was found to be the right one from the experiments made on the entire eggs.) The enucleated fragments thus treated were then put back into the sterilized sea-water. The water was changed once. After from five to ten minutes the fragments were studied in a compressorium, but not compressed. Some of the fragments subjected to the above treatment were fixed with acetic sublimate (saturated solution of sublimate 98 parts plus glacial acetic acid 2 parts). When they reached 90 per cent alcohol they were stained with erythrosin and, after clearing, they were fastened on a piece of ulva by means of celloidin-clove-oil. The iron-alum-hæmatoxylin method was used for all sections. While the enucleated fragments were in the CaCl<sub>2</sub> solution, the nucleated ones were stained with aceto-carmin to see that the two ends of the first maturation spindle were not injured by the operation.

b. *Cytasters Studied in Life.* First I shall take up one particular case of the formation of cytasters as an example. The egg was cut in a plane a little below the equator. In the animal half one could see a dumbbell-shaped clear area, indicating the first maturation figure (Fig. 1a), while in the vegetative half not a single clear spot was present (Fig. 1c). The animal half was stained with

aceto-carminé. As is shown in Fig. 1b, there came into view a complete mitotic figure. The enucleated fragment, after five minutes' stay in the sterilized sea-water, was transferred into the  $\text{CaCl}_2$  solution, where it was first plasmolyzed. (Fig. 1d.) In



FIG. 1 ( $\times 330$ ).

1a, Nucleated half with first maturation figure. 1b, the same stained with acetocarmine. 1c, enucleated half of the same egg before  $\text{CaCl}_2$  treatment. 1d, the same plasmolyzed in  $\text{CaCl}_2$  solution. 1e, the same transferred to sterilized sea-water. 1f, the same after the appearance of the clear area containing cytasters (section shown in Fig. 8).

the cytoplasm no visible change took place while in the salt solution, nor could even the primary radiation be seen. After an hour it was put back into the sterilized sea-water, afterward the water was changed. The fragment became perfectly spherical (Fig. 1e), but there was no visible indication of the cytaster formation. After about ten minutes a clear spot with rays around it appeared near the center of the fragment. (Fig. 1f.) This central area grew very rapidly, reaching after half an hour almost the size of the germinal vesicle. It ceased to enlarge at this stage. During the growing period the rays became indistinct, so that the clear area gave the appearance of a vesicle. It should here be noted that the size of the fragment did not change perceptibly during the formation of the clear area. (*cf.* Fig. 1e and 1f.)

The above case with a large spherical central area is the commonest mode of appearance of the cytasters, while quite often the clear area has an irregular outline or a deep indentation on one side. Fig. 2a shows an enucleated fragment, in which, under the same treatment, appeared two clear areas with fine radiation. These two made their appearance simultaneously at two separate spots. They, therefore, are not the division product of one original aster. The stained nucleated half from the same egg is represented in Fig. 2b. In one enucleated fragment three clear spaces of about the same size appeared, as is shown in Fig. 3. In another three areas of different shape were found. (Fig. 4.) In still another case a splendid display of the cytasters was seen (Fig. 5a),<sup>1</sup> dozens of small asters being scattered throughout the fragment; the enucleated half of this egg is drawn in Fig. 5b.

*c. Cytasters Studied in Sections.* Nine enucleated fragments subjected to the  $\text{CaCl}_2$  treatment were fixed after from twenty to thirty minutes' sojourn in the sterilized sea-water and cut into sections. One of them had no asters in it; the mode of appearance of the cytasters studied in the remaining eight fragments may conveniently be classified in three categories: *a*, the cytasters found throughout the cytoplasm; *b*, one single large aster at the center of the fragment, and *c*, a group of cytasters in a large central clear area.

*a.* In four fragments several cytasters made thier appearance

---

<sup>1</sup>This fragment has been drawn greatly compressed. Some twenty asters are left out in this figure owing to the difficulty of drawing all of them in perspective.

FIG. II ( $\times 330$ ).

2a, Eucleated fragment with two cytasters. 2b, nucleated fragment from the same egg stained with acetocarmine. 3, enucleated fragment with three cytasters. 4, enucleated fragment with five cytasters; three of them have fused. 5a, enucleated fragment with many cytasters. 5b, nucleated fragment from the same egg.

throughout the cytoplasm, as is shown in Fig. 6, corresponding to the pieces studied in living state. (Fig. 2a, 3, 4 and 5a.) In one of the fragments as many as twelve cytasters were found. In case a few cytasters are produced they have a tendency to come together near the center of the fragment. Another point to be noted is that the larger the number of cytasters in a fragment the smaller the aster. The central portion of the fragment stains lighter than the outer. Besides fine yolk granules large ones of various sizes are found. The latter kind of granules is more thickly disposed near the periphery than the center.

b. In one fragment a single aster is found near the center with an enlarged centrosome. (Fig. 7.) The general character of the cytoplasm is the same as those of the four fragments described under a.

c. In three fragments I found a group of cytasters in a central clear area. This type occurs more frequently than any other, as I learned from the study of living fragments. Fig. 8 is a section through the same fragment represented in Fig. 1f. The entire cytoplasm is packed with large yolk granules, which look as if

they were crowded together by the central accumulation of hyaloplasm. They stain very dark and resist extraction by the iron-alum solution for a considerable length of time. In fact, when these granules become dark blue both the rays and centrioles are found completely decolorized. At the center there is a large clear area of almost the size of the germinal vesicle. In it some two or three dozens of cytasters are seen, most of them being situated near the periphery. Each aster bulges out a little toward

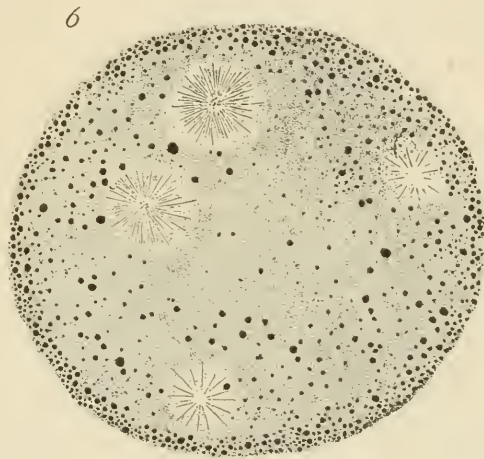
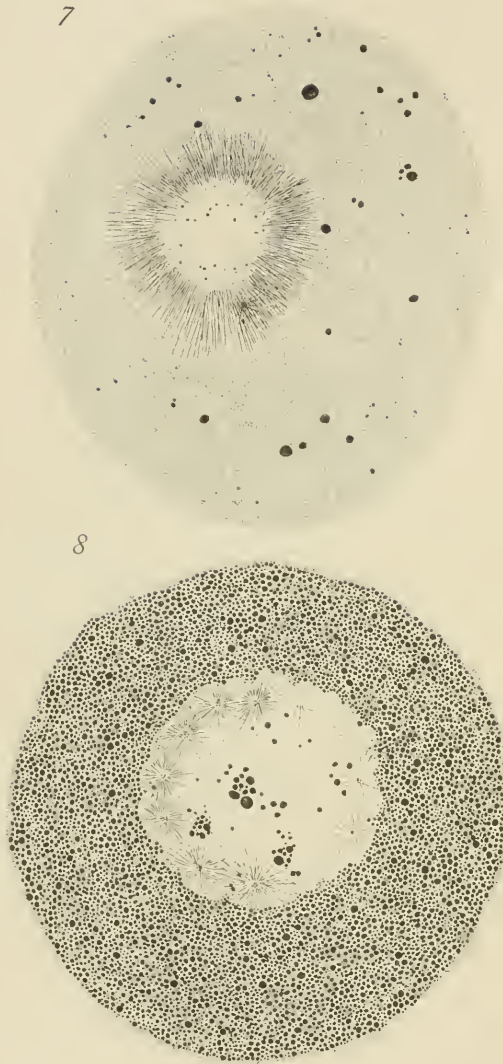

FIG. III ( $\times 913$ ).

6, Section of an enucleated fragment, in which several cytasters have been produced, by  $\text{CaCl}_2$  solution; four cytasters are seen in the section; the centrioles of the two cytasters are in the next section.

FIG. IV ( $\times 903$ ).

7, Section of an enucleated fragment, in which a single cytaster has made its appearance. Notice enlarged centrosome and many centrioles in it. 8, section of the enucleated fragment, represented in Fig. 1f, with central clear area containing many cytasters and yolk-islands.

the yolk part, so that in sections as many indentations are present as the number of intervals between two asters. It should be noted that the yolk granules near the clear space in over extracted preparations shows a radial arrangement (Dotterstrahlung of Häcker), and clear streaks run between the rows of yolk granules. These streaks, however, do not go far into the yolk layer.

In both the types *a* and *c* the structure of the cytasters is very similar, so much so that it is hardly necessary to describe them separately. The only difference between them lies in that in the type *a* the rays are much stronger than those of the type *c*. Some of the cytasters are drawn with a higher power. Fig. 9a and 9b are the same ones shown in Fig. 6; the former is the upper one and the latter the lower one. Fig. 9c is from a section of another fragment in which only three large

cytasters have arisen. At the center of the cytasters there is always a little accumulation of centropiasm; in Fig. 9c this has enlarged a good deal. The ray system around the centropiasm is exactly the same as that of the normal asters. Many rays extend quite far into the yolk region. A few stronger rays go through the centropiasm and reach the center, while most of them start from the periphery of the centropiasm. No marked archiplasmic differentiation can be detected, but there is a little difference in the nature of rays between the part of rays running through the yolk layer and that within the central portion of the cytaster free from yolk granules. This relation is clearly seen in Fig. 6. At the center of the cytaster are always found a few dark granules of various sizes. In small cytasters, where there is very little centropiasm, the granules are crowded together (Figs. 9a and 9b), while in case the centropiasm is enlarged the granules are found farther apart from one another. In no case I was able to find at the center either a single granule or the granule at the division stage.

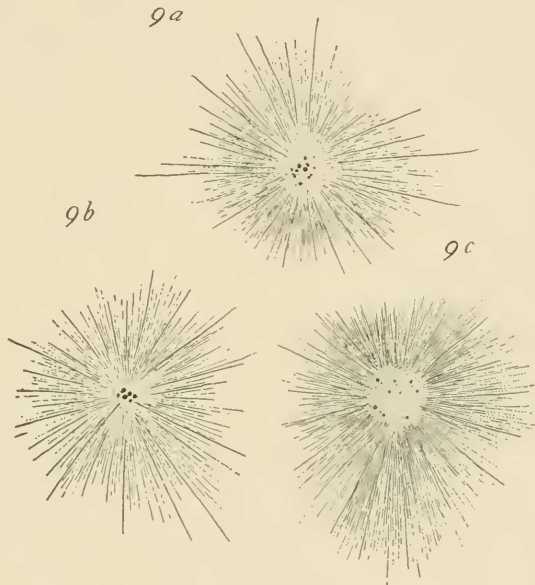
FIG. V ( $\times 2284$ ).

9a and b, Cytasters from the section shown in Fig. 6, more highly enlarged. 9c, cytaster with enlarged centrosome and several centrioles in it, showing intermediate stage between the cytasters 9a and b, and the one shown in Fig. 7.

In the section represented in Fig. 7 only one large cytaster occupies the central part of the fragment and the centropiasm is of enormous size with many dark granules. The rays are comparatively short and not very straight. They intercross one another, giving a felt-like layer.

In the section represented in Fig. 7 only one large cytaster occupies the central part of the fragment and the centropiasm is of enormous size with many dark granules. The rays are comparatively short and not very straight. They intercross one another, giving a felt-like layer.

10

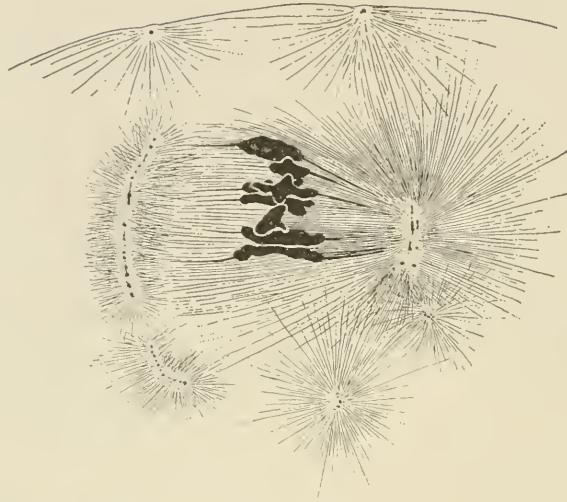

11

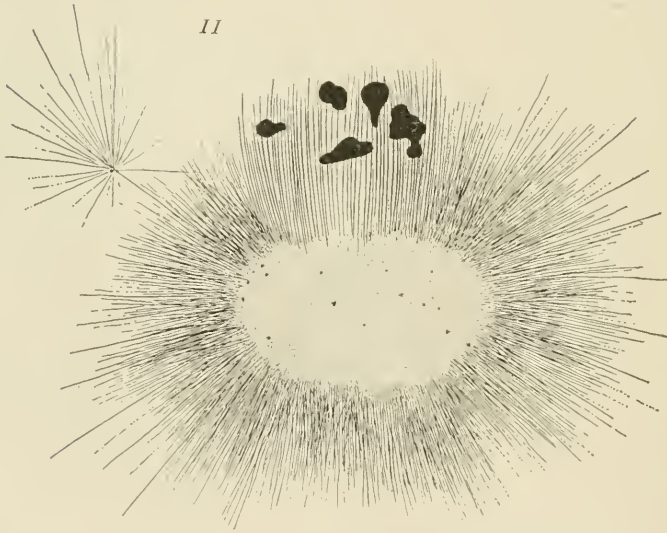
FIG. VI ( $\times 2182$ ).

10, First maturation figure ( $\text{CaCl}_2$  entire egg), showing abnormal multiplication of centrioles in enlarged centrosome. 11, central aster of first maturation figure ( $\text{CaCl}_2$  entire egg) with centrosome of enormous size and many centrioles in it.



d. *Nature of the Central Granule and Development of the Cytaster.* It is highly important to determine whether the dark granules found in the cytaster of the enucleated fragments now under consideration are real centrioles or not. The direct comparison of these cytasters with the asters of the normal egg is, I think, not just for the reason that, even if the normal aster did appear in the enucleated fragment, it would have been acted at the same time by the salt solution. The more reasonable way, it seems to me, would be to compare our cytasters with the asters found in the entire  $\text{CaCl}_2$  eggs.

Fig. 10 shows a portion from a section of an entire egg shaken fifteen times, treated for an hour with the  $\text{CaCl}_2$  solution and fixed after ten minutes' sojourn in sea-water.<sup>1</sup>

In the section one observes a large centrosome at either end of the first maturation-spindle; single at the right, and double at the left—the latter undoubtedly a division-product of one original centrosome, as shown by the course of the spindle fibers. Besides these, four asters are found in the vicinity. Noteworthy is the abnormal growth of the centrosome and extraordinarily rapid multiplication of the centrioles in the centrosomes. (*cf.* Wilson, '01, Figs. 24, 25 and 34.)

Another section shown in Fig. 11 illustrates these points very clearly. This is from an egg shaken fifteen times, treated with the  $\text{CaCl}_2$  solution for an hour and killed after five minutes' sojourn in sea-water. Only the central aster of the first maturation mitosis is pictured here. (*cf.* Morgan, '99, Pl. 10, Fig. 67.) The centroplasm of colossal size is surrounded by irregular rays, and in it one sees a number of dark stained granules. That these granules are really the centrioles can clearly be demonstrated in Morgan's figures (Pl. 10, Figs. 68, 70 and 60B), each granule having acquired a new ray system about it.

From the above two examples it will be seen that  $\text{CaCl}_2$  has the power to call forth two independent phenomena at the same

<sup>1</sup>This lot of eggs was originally intended for the study of cytasters in enucleated fragments obtained by shaking, but quite a number of eggs escaped from being broken. It is noteworthy that shaking has no effect at all on the mitotic figure, nor are the cytasters produced by it. We may, therefore, safely look upon all the changes that have taken place in the section about to be described, as due to the action of the  $\text{CaCl}_2$  solution. Although it may be claimed that these changes are caused by the combined action of shaking and  $\text{CaCl}_2$ , yet I think the comparison does not lose its validity for our present purpose, since the operation of cutting might give the egg as strong a shock as shaking does.

time, one an acceleration of the division rate of the centriole and the other an enlargement of the centrosome. One who is familiar with the literature soon finds that number, shape and size are not the criteria of the centriole. Meves describes a group of centrioles in the first maturation mitosis of the oligopyrenous spermatozoon of *Paludina* ('03, Pl. 3, Figs. 70 and 78). Heidenhain's microcenters in the leucocytes are another example, although these may be brought about by some pathological conditions, as suggested by Boveri ('01, pp. 21 and 22). The spongy or pluricorpuscular centrosomes have been observed by Wilson in the  $MgCl_2$  egg of *Toxopneustes* ('01, Figs. 70 and 82). These three examples will suffice for the present to show that the centrioles may vary in number. Generally speaking, the centriole has constant size to a particular kind of cells of an animal, yet considerable periodical fluctuation in size was noticed by the writer in the egg of *Cerebratulus*. The centriole is as a rule spherical, yet quite often we meet rod-shaped ones among the "normal" eggs. In abnormally treated eggs the size and shape of the centriole are exceedingly variable as is shown in the  $MgCl_2$  eggs (*Toxopneustes*) and  $CaCl_2$  eggs (*Cerebratulus*). (Fig. 10.) From this it will be seen that Vejdovský and Mrázek's conclusion that "die Centriolen in allen Fällen dieselbe Grösse und Beschaffenheit zeigen" seems untenable especially in abnormal cases.

Now let us consider how the cytasters which have appeared in enucleated fragments differ from the normal aster. The size and number of the dark granules are not constant in the cytaster, while in the normal aster the centrioles are almost of the same size and never exceed two in number. In some cytasters an enormous accumulation of the centropiasm takes place, while in the normal case the growth of the centrosome is limited. As we have already seen, all these abnormalities of the cytasters occur in the whole egg treated with the  $CaCl_2$  solution. We are, therefore, led to the conclusion that the dark granules at the center of the cytaster of the enucleated fragments are not mere metaplastic granules, but real centrioles.

My experiments and sections of the enucleated fragments are not numerous enough to ascertain the development of the cytaster. I may, however, be able to construct the history out of the material at hand without great error. According to the distribution of the centers in enucleated fragments we shall get two different types

of appearance of the cytasters; in one case the cytasters will develop throughout the fragment as in Fig. 6, while in the other one, two or three cytasters will appear near the center. Suppose in the latter case these cytasters grow to a considerable size, accompanied by the multiplication of the centrioles, then we shall have a condition somewhat similar to that shown in Fig. 7 (in this case it should be mentioned only one cytaster has been formed). Meanwhile the rays degenerate, leaving radiating line of yolk granules behind. The granules are pushed out as the centrosome grows. In case two or three cytasters appear they finally fuse together, giving rise to a huge central space. The yolk granules found as islands in the clear area may be the remnant of the interastral spaces. In fact, in some cases the yolk island is connected by a narrow bridge with the peripheral yolk layer. Then most of the centrioles move out toward the periphery of the clear space. Each centriole acquires a daughter ray system around it. The condition shown in Fig. 8 is thus reached. (Morgan, '99, Pl. 10, Figs. 67, 68, 70 and 60B.)

B. *Enucleated Fragments Treated with the CaCl<sub>2</sub> Solution, Time-Sterilization.*

To test whether the formation of the cytasters in the enucleated fragments be due to the action of the CaCl<sub>2</sub> solution or to the heat-sterilized sea-water I made a few experiments using sea-water kept for two days, the precautions and subsequent treatment being the same as Experiment A.

The cytasters appeared exactly in the same way as the experiments in which the heat-sterilized sea-water was used. Two fragments are shown in Fig. 12a and 12b. One piece was cut into sections. The cytological characters of the cytasters were similar to those of Fig. 8.

From this experiment it will be seen that the formation of the cytaster is entirely due to the action of CaCl<sub>2</sub>.

C. *Enucleated Fragments Treated with the MgCl<sub>2</sub> Solution, Heat-Sterilization.*

An enucleated fragment was put in the MgCl<sub>2</sub> solution used by Morgan (3.5 per cent of MgCl<sub>2</sub> in the sterilized sea-water). When I examined this fragment after half an hour a clear area

had been developed to a fairly large size. (Fig. 13a.) The nucleated half of the same egg was stained and the mitotic figure was found intact. (Fig. 13b.) The enucleated fragment was cut into sections. The general character of the cytoplasm is very similar to that of Fig. 7, while the large aster (Fig. 14a) at the center shows totally different features from any other that

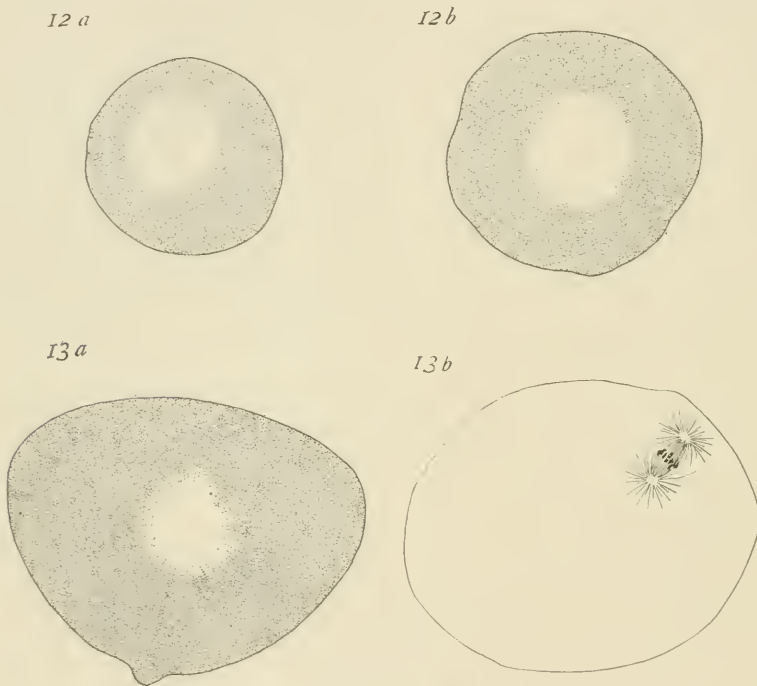

[FIG. VII ( $\times 330$ ).

*12a* and *b*, Enucleated fragments containing cytasters produced by  $\text{CaCl}_2$  solution, time-sterilization. *13a*, enucleated fragment with cytaster produced by  $\text{MgCl}_2$  solution, heat-sterilization. *13b*, nucleated fragment from the same egg as *13a*, stained with acetocarmine.

come under my examination. The center (centrosome?) is elongated; no central granules could be made out. Around this center long strong rays radiate. They look very brittle, judging from the fact that some rays show jagged broken edges. For comparison I reproduce a central maturation aster (Fig. 14b) from an entire egg kept in 3.5 per cent solution of  $\text{MgCl}_2$  in sea-

water for twenty-two minutes after the first maturation mitosis reached the metaphase. The centriole is here obscured by the strong rays. Striking is the similarity between Figs. 16 and 17. (*cf.* Morgan, '99, Pl. 10. Figs. 54c, 55, 57— $MgCl_2$ , and Fig. 63— $NaCl$ .) The strong-rayed asters seem to be due to the peculiar action of  $MgCl_2$  on the egg of *Cerebratulus*. Further experiments are necessary to find out whether the centrioles are produced by  $MgCl_2$ .

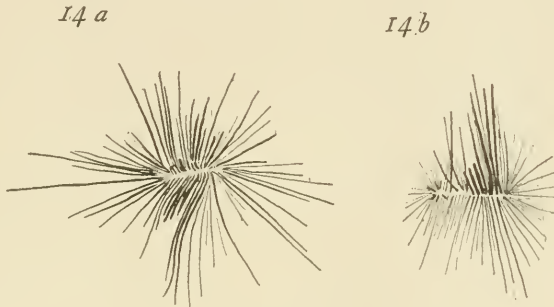

FIG. VIII ( $\times 903$ ).

14a, Cytaster from section of the fragment shown in Fig. 13a. 14b, central aster of the first maturation figure, modified by  $MgCl_2$  solution.

#### IV. EXPERIMENTS ON THE EGG BEFORE THE DISSOLUTION OF THE GERMINAL VESICLE. $CaCl_2$ SOLUTION, HEAT-STERILIZATION.

To determine whether the cytasters are produced by the  $CaCl_2$  solution before the dissolution of the germinal vesicle the following experiments were carried out:

In 1903 ten enucleated fragments were cut from the eggs just released into water and were treated with the  $CaCl_2$  solution. No cytasters appeared in any of these fragments.

In 1904 three parallel experiments were made on the egg fragments taken from one individual.

I. Five enucleated fragments were cut from eggs immediately after they were released into the sterilized sea-water. These fragments were kept in the water and then transferred into the  $CaCl_2$  solution. After an hour's sojourn in this solution they were put back to the sterilized water, which was changed once. *No asters appeared.*

II. Five enucleated fragments were cut from the egg immediately after they were released and kept for an hour in the sterilized water; first, in order to give the enucleated fragments more time to ripen, so to speak, and second, for the sake of uniformity with the following experiment. Then the fragments were transferred into the  $\text{CaCl}_2$  solution. After an hour they were put back into the sterilized sea-water. *In none of the fragments did cytasters appear.*

III. (Control) Eggs were kept for an hour in the sterilized sea-water. Meanwhile the germinal vesicle faded and the first maturation mitosis reached the metaphase. Five enucleated fragments were cut and treated in the same way as Experiment A, a. *In all the fragments cytasters were found.*

The above three experiments<sup>1</sup> show clearly that the cytasters do not appear in the enucleated fragments from the egg immediately after release.

#### V. REVIEW OF LITERATURE.

An experimental study of the cytasters was for the first time made by Morgan. In 1893 he saw refractile drops in the egg of *Arbacia* treated with the sea-water to which a little  $\text{NaCl}$  (2 per cent) had been added. In the winter of 1894-95 he extended his experiments on the egg of *Sphærechinus* to see if the refractile drops, which he later found to be the cytasters, cause the division of cytoplasm. Although his expectation failed, yet, from the studies along this line, he reached important results which may be summarized as follows:

---

<sup>1</sup>The following objection might be raised. The enucleated fragments for Experiments I and II were smaller than those for Experiment III, and cytasters might not have been able to develop for this reason. In fact, however, the former were only a little smaller than the latter; *i. e.*, about the size of a fragment represented in Fig. 12a. The minimal size of the cytoplasm which can produce cytasters is, I think, by far smaller than any piece I used for the above experiments. In this connection I might cite a case in which an egg was cut into three pieces, one nucleated and the other two enucleated. In one of the enucleated fragments the aster was found.

Another point: the eggs for experiment I and II were cut; as I stated expressly, immediately after release. Sections of the normal eggs clearly show that a few asters do rarely appear after from twelve to fifteen minutes' stay in sea-water, in spite of the fact that the nuclear membrane remains apparently intact. The asters thus developed prior to the dissolution of the germinal vesicle, lie usually on or close to the nucleus and very rarely far away from it.

1. Asters and pseudasters (*i. e.*, asters without the centriole) are produced *de novo* in the cytoplasm by the action of some salts.<sup>1</sup> The presence or absence of the centriole in the aster is not due to the action of fixing fluid ('00, p. 522). The centriole in the cytaster is sometimes single, sometimes a group of granules ('96, p. 343).

2. The first step to the cytaster formation is a local accumulation of hyaloplasm, rays are formed in it, and then the centrioles develop at the center ('99, pp. 477 and 513).

3. The cytasters become more distinct when the nuclear membrane fades, while they become less marked when the nuclei come into the resting stage ('99, pp. 468, 469 and 517).

4. In the unfertilized egg cytasters develop more slowly and are less distinct than those in the fertilized egg ('96, p. 344; '99, p. 473).

5. No cytasters appear before the dissolution of the germinal vesicle in the egg of *Sphærechinus* ('96, pp. 348 and 349), and in *Sipunculus* ('99, p. 502).

In his paper on the nature of the centrosome Boveri ('01) touches on the question of the cytaster in several places, although he has no observations of his own. He distinguishes two kinds of cytasters: one assumed to be descendants of the ovocenter, and the other artificial asters (p. 169). Central bodies may be present in the latter, yet their identification as centrioles is doubtful, unless their division is actually observed. In other words, he does not accept the formation *de novo* of the centrosome and seems to incline to the conclusion that every centrosome in the egg is a division product of the ovocenter.<sup>2</sup>

In eggs of *Toxopneustes* treated with solutions of  $MgCl_2$  Wilson ('01) confirmed the formation *de novo* of the centriole from the study of sections as well as living eggs. Moreover, he, for the first time, proved the above fact experimentally in enucleated fragments. His results are as follows:

<sup>1</sup> It is perhaps worth pointing out that R. Hertwig ('02) misquotes Morgan's experiment, stating that he obtained cytasters in enucleated egg-fragments (p. 19). This is an error, the experiment having been done for the first time by Wilson ('01). Fischer and Ostwald ('05) cite Morgan's merogony experiment as giving the same result (p. 253), but this is also erroneous and in the papers they referred to no experiment giving this result is described.

<sup>2</sup> After the appearance of Wilson's paper ('01), Boveri accepted the formation *de novo* of the centrosome ('02, p. 40).

1. Asters having the power of division arise in the cytoplasm independent of the nucleus. These asters first appear simultaneously *in situ* scattered through the cytoplasm and, though plainly visible in the living eggs, show no evidence of genetic connection with one another. At a later period, however, they multiply by division synchronously with the division of the nuclear asters.

2. At first vague clear spots appear in the cytoplasm, which gradually become surrounded by radiating lines of granules and finally assume the form of asters. In sections central granules appear in the accumulations of hyaloplasm and afterward rays are formed about them.

3. In the cytasters there is a central granule which is a true centriole formed *de novo* in cytoplasm. The central bodies divide as in the ordinary asters and thus give rise to the centers of the daughter aster. Sometimes two centrioles are found in a centrosome (p. 561).

4. In enucleated fragments obtained by shaking the unfertilized eggs and treated with  $MgCl_2$  the typical cytasters often containing the centrioles are found. Moreover, these asters may multiply by division (p. 581).

Wassilieff ('02) made interesting experiments on the egg of *Strongylocentrotus lividus*. The centriole, he claims, is formed by the interaction of the nuclear fluid and cytoplasm. "Der Kern sondert in das Protoplasma eine gewisse Substanz ab, welche zur Bildung eines Centrums in Protoplasma Veranlassung giebt und um dieses letzteres herum lagert sich die protoplasmatische Strahlung ab" (p. 769). I perfectly agree with him, so far as this conclusion is concerned, though his evidence was not strong enough to establish it. Moreover, he fails to consider what seems to be of prime importance; he insists that the nuclear fluid flows out as the egg nucleus fades. If so, why should the cytasters in some cases appear, while the egg nucleus is intact? He states that the cytasters must have originally been connected with the nuclear aster. To bear out this view he gives a case in which a cytaster is connected with the nucleus. The connection seems to me to be merely secondary one. He raises objections to Wilson's results on the formation *de novo* of the centrioles in the enucleated fragments obtained by shaking on the ground that if the eggs are so violently shaken that they break



up into fragments, the membrane of the egg-nucleus may be torn and consequently the cytasters are formed by the intermingling of the nuclear fluid and cytoplasm.

Meves ('02, *a*, *b*, and '03) thinks that the cytasters may arise in the following way: Numerous centrioles may be handed down to the egg from the last division of the multiplication period somewhat as in the formation of the oligopyrenous spermatozoon in *Paludina*. He, therefore, holds the view that cytasters may be derived from preëxisting centrioles which have acquired a new ray system around them by the action of salt solution ('02, *a*, p. 155). He criticises Wilson's experiment on enucleated fragments on a ground slightly different from Wassilieff's objection, assuming that, even if there be no preëxisting centrioles in the cytoplasm, the egg center may by shaking be thrown off in the enucleated fragments ('02, *a*, p. 155).

It was in order to test the above two possibilities that Professor Wilson suggested to me two years ago to repeat his experiment on enucleated fragments by cutting unfertilized eggs in two singly and to treat the enucleated piece with some salt-solution. This I tried both in the egg of *Cerebratulus lacteus* and of *Echinarachnius parma*<sup>1</sup> in the summer of that year.

In the meantime appeared Petrunkevitch's paper on artificial parthenogenesis ('04). He took up the same form as that studied by Wassilieff, *Strongylocentrotus lividus*, in which I fully realize how difficult the fixation of the centriole is. Surprisingly enough Petrunkevitch was led to the conclusion that *in the egg of this sea-urchin there is no centriole at all* (p. 32).<sup>2</sup> His whole argument, therefore, applies to the centrosome not to the centriole. He denies the formation *de novo* of the centrosome and tries to rescue Boveri's idea of continuity of the centrosome. He came to this conclusion from the study of sections of the eggs, the "stages" of which were selected arbitrarily. Despite this he insists that his view regarding the origin of cytasters is thus con-

<sup>1</sup>In the egg of this echinoid I used the following solution: 11.8 per cent of  $MgCl_2$  ( $=\frac{1}{8}$  m.  $MgCl_2$ ), 1 part; sea-water, 1 part. In two cases out of eighteen fragments the cytasters were formed. Total preparations of these two pieces showed that they had no nucleus in them. In passing I should state that the following solution is the best to induce parthenogenesis in the egg of *Echinarachnius*: 18.6 per cent of KCl ( $=\frac{2}{8}$  m. KCl), 15 parts; sea-water, 85 parts.

<sup>2</sup>Noteworthy is the fact that, judging from his figures, he actually saw the centrioles, but mistook them for reduced centrosomes (not in Boveri's sense), *e. g.*, Pl. 2, Fig. 24.

firmed by the fact "in glänzender Weise" (p. 45). Besides repeating Wilson's experiment on enucleated fragments obtained by shaking he also made cutting experiments. In both cases he very seldom saw cytasters; none of them had centers and they faded earlier than the true asters in the control eggs (p. 36). Centrosomes were never observed in the enucleated fragments. His general conclusion is, therefore, exactly in agreement with the position taken by Boveri in his *Zellstudien IV, i. e.*, there are two kinds of cytasters, one containing the centrosome, the other devoid of a centrosome. The centrosome of the former are supposed to arise solely as division products of preëxisting ones, and only the latter can be produced *de novo* in the cytoplasm.

Wilson ('04) in his rejoinder to Petrunkevitch's paper points out that the evidence given in that paper does not sustain this conclusion and that the negative result is insufficient to disprove the formation *de novo* of the centrosome. The results brought forward in the present paper fully sustain this position.

#### VI. CONCLUSIONS.

My experiments consist in cutting singly unfertilized eggs by horizontal section at two different periods and in treating the enucleated fragments thus obtained with a solution of  $\text{CaCl}_2$ . By these experiments I think I have established the facts, (a) that at the period of the metaphase of the first maturation mitosis cytasters can arise at any point of the egg,<sup>1</sup> but (b) that prior to the fading of the germinal vesicle cytasters never arise. (*cf.* footnote on p. 304.) In all the cytasters developed in enucleated fragments there is a central group of dark staining bodies, which I do not hesitate to identify as multiplied centrioles. It is to be regretted that I did not find in any enucleated fragment either a single centriole or one in division. This, however, does not invalidate the general conclusion for the reason that centers of exactly the same nature as those in enucleated fragments are found in the nuclear division figure in whole  $\text{CaCl}_2$  egg.

<sup>1</sup>My experiments show that cytasters appear in the vegetative half. It was, however, impossible to test experimentally whether the cytasters develop in the vicinity of the first maturation mitotic figure. Nevertheless it will not be unreasonable to infer that they may so arise there from the fact that the whole  $\text{CaCl}_2$  egg has many cytasters near the animal pole as well.

My cutting experiments were performed at two periods, one immediately after release and the other an hour and a half later. From these we can by no means determine exactly when the cytoplasm acquires the power of producing the centrioles and ray system. What brings about the change in the characters of the cytoplasm during this interval? In all probability the intermingling of the nuclear fluid and cytoplasm during the time of fading of the germinal vesicle gives to the cytoplasm the aster producing power. A striking difference between the matured and immature cytoplasm has been described by many observers. Delage emphasizes the fact that during this period, when the cytoplasmic maturation takes place, the eggs become fecundable both in *Strongylocentrotus* ('99) and in *Asterias* ('01.) Wilson verifies this phenomenon in the eggs of *Cerebratulus* ('03, p. 417). Spermatozoa can enter immature eggs freely, but they remain undeveloped. (O. and R. Hertwig, '89, p. 199; Wilson, '96, p. 149.) In immature cytoplasm not only is the development of the sperm nucleus and ray system inhibited, but also the centrioles do not arise in eggs, even if they are treated by salt solutions. Morgan ('99) noticed that cytasters did not develop either in the egg of *Sphærechinus* or of *Sipunculus* before maturation begins, and I was told by Professor Wilson that he observed the same fact in the  $MgCl_2$  egg of *Toxopneustes*. Leaving open for the present the question how the nuclear fluid acts upon the cytoplasm we can at least say that the matured cytoplasm is ready to produce or, in other words, has the power to form centrioles as well as rays as a result of certain stimuli, this being in our case a  $CaCl_2$  solution.

As to the origin of the centrioles in the cytasters there are two possibilities besides the one just mentioned. First, as suggested by Meves the centrioles might multiply in the cytoplasm during the growth period of the egg and become the centers of the cytasters under the action of a salt solution. Such an assumption is not in contradiction with what has just been said, that asters do not develop in unmaturing cytoplasm even when the spermatozoon brings a centriole into the egg, since the centrioles might be present, but incapable of producing asters *until the germinal vesicle fades*. There is another possibility similar to the above, namely, that centrioles may be present as such in the nucleus and, at the dissolution of the germinal vesicle, escape into the cytoplasm

where they acquire rays and thus give rise to the cytasters. Apart from the fact that neither of these assumptions is supported by any direct observations they contradict the definition of the centrosome as given by Boveri ('01, pp. 132, 162, etc.) that the organ is single (or double by anticipation). A multiplication of centrioles *capable of producing centrosomes* is nowhere known to take place unless it be in abnormal or degenerating cell, such as the giant cells or the oligopyrenous spermatozoa. It may be said that centrosomes (centrioles) arise by the enlargement of ultra-microscopical granules or plastids that coexist with the visible astral centriole. This is quite possible, but if visible centrioles may thus arise in addition to the visible ones already existing and independently of them *centrosome formation de novo in the ordinary sense of this expression is demonstrated none the less*. The results of my cutting experiments, therefore, I believe, lead us to the unavoidable conclusion that the centrioles are formed *de novo*, as Wilson maintained.

In conclusion one word about the nature of the sperm centriole. One might be readily led to infer from what I have said that the sperm centriole in the normally fertilized egg may arise in the same manner as those found in the cytasters. In *Cerebratulus*, at least, this is not the case, for I have been able to show that the centriole, as such, is actually brought into the egg in the middle piece of the spermatozoon. Detailed evidence in support of this statement will be published hereafter.

#### VII. SUMMARY.

1. When subjected to the action of a solution of  $\text{CaCl}_2$  enucleated fragments of unfertilized egg of *Cerebratulus lacteus*, obtained by cutting the eggs singly at the metaphase of the first maturation mitosis, develop true asters containing central bodies. The corresponding nucleated fragments show the typical maturation spindle.

2. Cytasters do not, however, appear in enucleated fragments from unfertilized eggs before the fading of the germinal vesicle.

3. The central bodies of the cytasters developed in enucleated fragments are centrioles identical in structure with those in the nuclear asters of whole eggs similarly treated.

4. Centrioles, therefore, can be produced *de novo* in the matured cytoplasm (*i. e.*, after the dissolution of the germinal vesicle).

Zoölogical Laboratory,  
Columbia University.  
January 23, 1905.

## VIII. LITERATURE.

- BOVERI, TH., '01.—Ueber die Natur der Centrosomen: Zellenstudien, Heft 4.  
'02.—Das Problem der Befruchtung.
- DELAGE, YVES, '99.—Étude sur la mérogonie: Arch. Zool. exp. (Ser. 3), 7.  
'01.—Études expérimentales sur la maturation cytoplasmique et sur la parthénogénèse artificielle chez les échinodermes: Arch. Zool. exp. (Ser. 3), 9.
- FISCHER, M. H., AND OSTWALD, W., '05.—Zur physikalisch-chemischen Theorie der Befruchtung: Arch. f. d. ges. Physiologie. 106.
- HERTWIG, O. AND R., '87.—Ueber den Befruchtungs- und Teilungsvorgang des tierischen Eies unter dem Einfluss äusserer Agentien: Jen. Zeit. 20.
- HERTWIG, R., '02.—Die Protozoen und die Zelltheorie: Arch. Protistenkunde 1.
- MEVES, F., '02.—Ueber die Frage ob, die Centrosomen Boveri's als allgemeine und dauernde Zellorgane aufzufassen sind: (a) Verhandl. der anat. Gesell. in Halle. b) Mitteilungen Aertz. Verein Schlesw.-Holst. Jg. 10, Nr. 6.  
'03.—Ueber oligopyrene und apyrene Spermien und über ihre Entstehung, nach Beobachtungen an *Paludina* und *Pygaera*: Arch. mikr. Anat. 41.
- MORGAN, T. H., '96a.—On the production of artificial archoplasmic centers: Rept. of the Am. Morph. Soc., Science N. S. 3, No. 54.  
'96b.—The production of artificial astrospheres: Arch. Entwm. 3.  
'98.—The effect of salt-solutions on the unfertilized eggs of *Arbacia*: Science N. S. 7, No. 164.  
'99.—The action of salt-solutions on the unfertilized and fertilized eggs of *Arbacia* and of other animals: Arch. Entwm. 8.  
'00.—Further studies on the action of salt-solutions and other agents on the eggs of *Arbacia*: Arch. Entwm. 10.
- PETRUNKOVITSCH, A., '04.—Künstliche Parthenogenese: Zool. Jahrb. Supplement 7.
- VEJDOVSKÝ, F. AND MRÁZEK, A., '03.—Umbildung des Cytoplasma während der Befruchtung und Zellteilung, nach den Untersuchungen am *Rhynchelmis*-Eie: Arch. mikr. Anat. 62.

- WASSILIEFF, A., '02.—Ueber künstliche Parthenogenesis des Seeigel-Eies: Biol. Centbl. 22 No. 24.
- WILSON, E. B., '96.—The Cell: 1st Ed. New York.
- '01.—A cytological study of artificial parthenogenesis in sea-urchin eggs. Experimental Studies in Cytology I: Arch. Entwm. 12.
- '03.—Experiments on cleavage and localization in the nemertine egg: Arch. Entwm. 16.
- '04.—Cytasters and centrosomes in artificial parthenogenesis: Zool. Anz. 28.
- YATSU, N., '04.—Aster formation in enucleated egg-fragments of *Cerebratulus*: Science N. S. 20, No. 521.

# A STUDY OF THE GERM CELLS OF APHIS ROSÆ AND APHIS CENOTHERÆ.<sup>1</sup>

BY

N. M. STEVENS.

*Associate in Experimental Morphology, Bryn Mawr College, and Research Assistant, Carnegie Institution of Washington.*

WITH 4 PLATES.

I. Material and Methods.....	314
II. Parthenogenetic Development.....	314
1. Female Line.....	314
2. Male Line.....	316
III. The Winter Eggs.....	318
1. Early Development and Growth.....	318
2. Maturation.....	320
IV. Spermatogenesis.....	321
V. General Discussion.....	323
1. Mendel's Law, and the Individuality of the Chromosomes.....	323
2. Maturation of Parthenogenetic Eggs.....	324
3. Determination of Sex.....	326
VI. Summary of Results.....	329

This work was undertaken in connection with a series of experiments on sex-determination in Aphids. On approaching the subject, it was found that very little is known concerning the oogenesis and spermatogenesis of these insects. Blochmann ('87) showed that the parthenogenetic egg gives off one polar body, and the winter egg two; but I find no account of the number of chromosomes or the method of reduction in either egg, nor is there any published work on the spermatogenesis of Aphids. The present paper will be devoted mainly to the germ-cells, a few points in the early stages of parthenogenetic development being considered incidentally.

---

<sup>1</sup> This paper was awarded the prize of one thousand dollars offered in 1904 by the "Association for Maintaining the American Woman's Table at the Zoölogical Station at Naples, and for Promoting Scientific Research among Women."

## I. MATERIAL AND METHODS.

Sections of Aphids from various host plants—the rose, English ivy, honeysuckle, alder, arrow-head, *Oenothera*, and hop, were examined; but *Aphis rosæ* proved the most satisfactory for study of the ovogenesis of both parthenogenetic and winter eggs, and *Aphis œnothæræ* for the spermatogenesis.

Both the Aphids and the winter eggs were killed and fixed with Gilson's aceto-chloroform-sublimate mixture, which gives far better results than any other method tried. Very small Aphids were embedded whole; larger ones after removing the head and thorax. Sections were cut from  $5\ \mu$  to  $7\ \mu$  thick, and stained with Delafield's hæmatoxylin and orange G, or with Heidenhain's iron-hæmatoxylin. The former method of staining gives remarkably good differentiation for ordinary purposes. The latter is more satisfactory for the study of ovogenesis and spermatogenesis. Many slides stained at first with Delafield and orange, were restained with iron-hæmatoxylin for more careful study.

## II. PARTHENOGENETIC DEVELOPMENT.

1. *Female Line.*

Most of the stages in ovogenesis of parthenogenetic eggs and also early segmentation stages were obtained from sections of the unborn young of the viviparous female. For more advanced segmentation stages and early embryos very young Aphids were sectioned.

All the species examined have twelve ovaries in two groups as described by Balbiani ('69-'72). Oögonial mitoses were observed, but offered nothing of especial interest as the division figures are identical with other embryonic mitoses.

The resting oöcyte, before the growth stage of the ovum begins, has a very large nucleus in proportion to the size of the cell (Figs. 1 and 2). A large nucleolus occupies the center of the nucleus, and in addition to this the nucleus contains a linin reticulum and irregular masses of material, presumably chromatin, which does not take the hæmatoxylin stain at this stage.

One at a time the oöcytes at the posterior end of the ovary enlarge and push out into the oviduct, remaining, however, con-



nected by a stalk with the central core of the ovary (Fig. 1). As many as three eggs may be thus connected by stalks with the center of an ovary,—one egg just passing into the oviduct, another in maturation stage, and a third in 8 to 16-cell stage. As the oöcyte increases in size, the cytoplasm changes its staining reaction, coloring somewhat deeply with Delafield; and the nucleus shows various changes. The nucleolus disappears and the chromosomes become stainable at an early stage (Figs. 1, 3, 4, 5). As the egg rapidly enlarges the nucleus approaches the periphery at one side of the oval egg (Fig. 6). Just before maturation, clear vesicles appear in the cytoplasm and soon fuse forming large irregular spaces filled with a clear non-staining substance, presumably yolk material, separated from the general cytoplasm (Blochmann).

Fig. 7 shows the equatorial plate of a polar spindle in metaphase. There are 10 chromosomes of 5 different sizes. This is the somatic number, and there is therefore no synapsis or conjugation of chromosomes and no reduction in the maturation of the female parthenogenetic egg. The same number (10) and the same variation in size (5 pairs) is shown in the segmentation spindles and equatorial plate of Fig. 12. The maturation spindle in anaphase is well shown in Fig. 8; also the lacunar spaces in the interior of the egg.

The polar body is at first completely extruded from the egg and separated from it as seen in Figs. 8 and 9. It is distinctly a polar body not a "polar nucleus." Soon, however, it comes to lie within the boundary of the egg among the segmentation nuclei (Figs. 10 and 11). In such a stage as in Fig. 11, the polar body is easily recognizable by its clear cytoplasm and deeply-staining mass of chromatin. It lies in a sort of vacuole in the egg-cytoplasm. I have been able to follow the polar body as far as the stage shown in Fig. 13. The cytoplasm can no longer be distinguished from that of the egg; the chromatin mass is irregular in outline, usually stains less deeply and appears to be degenerating. I therefore feel sure that the polar body takes no part in the development of the embryo. Its inclusion within the egg is probably due merely to mechanical conditions, *i. e.*, to the pressure of the walls of the oviduct upon it, as it lies on the side of the oval egg.

There is only one point of especial interest in the later development, and that is the relation of the young embryo to the vitellaria.

This is shown in Figs. 14 and 15. Fig. 14 shows an embryo which has just begun to take in yolk (the "secundäre Dotter" of Will, '89). At the base of the embryo as figured are two conspicuous cells (*b*) which apparently guard a valvular opening in the wall of the oviduct, and recall the four guard-cells at the inner end of the embryonic pharynx of *Planaria simplicissima*. At the lower focus of the section the valve is slightly open and a small amount of yolk material has entered (Fig. 14, *a*). In Fig. 15 the valve is widely open and yolk cells are being taken into the embryo. Whether the embryo actively sucks in the yolk, or the yolk cells themselves are the active agents, it is impossible to tell, but the former seems more likely. Will ('89) describes the secondary yolk as forming in connection with the follicle epithelium and then being taken into the gastrula. In speaking of the work of Witlaczil ('84), he says, "Von seiner ganzen Darstellung ist nur das eine richtig, das der secundäre Dotter von Follikelepitheel seinen Ursprung nimmt," and later he says, "Diese innerhalb der Epithelverdickung producirte Dottermasse ist es nun welche in das Ei eintritt und demselben den sogenannten secundären Dotter liefert. Dass es sich dabei nicht um eine Einwanderung von Zellen . . ."

The close resemblance in structure between the secondary yolk and certain large cells in the body cavity of the mother was easily observed in the sections, but the relation between the embryo and the vitellaria described above was first seen in connection with the egg of *Aleurodes*, a related form, where the relation is much more conspicuous than in the Aphid. It was later traced with certainty in the winter egg and in the parthenogenetic embryo of the Aphid.

No variation could be detected in the development of ova which produce winged parthenogenetic individuals. The winged young can often be distinguished before birth, and some of the same brood may be winged, others apterous. The winged parthenogenetic individuals are migrants and their appearance seems to be conditioned by the amount or the quality of the food supply.

## 2. Male Line.

The mothers of the males are apterous and cannot be distinguished externally from the apterous females which produce female offspring. The ovaries show no difference in structure, unless it may be in size and number of the oöcytes, and only one

polar body is given off. In studying the development of male<sup>1</sup> eggs, one is at a disadvantage so far as the amount of available material is concerned, because only eggs connected with the ovaries of females which contain embryos large enough to be recognized as male can be utilized, while in the female line the best eggs for study are found in abundance in the larger embryos. No polar spindles were found in the few male eggs obtained. Figs. 17 and 18 show the polar body as it appears in eggs containing 4 and 8 nuclei. There is no indication of fusion of two polar bodies. In Fig. 18 the chromosomes are not so fully fused as in Fig. 17, but this is the condition at a corresponding stage in the female eggs. Examination of the segmentation spindles in male embryos and of spermatogonial mitoses makes it certain that the full somatic number of chromosomes is present until we come to the spermatocytes when reduction occurs. This is what we should expect had it not been claimed by Castle ('03) that the female character which is usually dominant in parthenogenetic insects is removed from the egg with the second polar body, thus allowing the recessive male element to assert itself. There is no evidence in my material of any difference between the maturation of the female parthenogenetic egg and that of the male egg, and until I can procure more material and examine the point further, I shall assume that the method of maturation of all parthenogenetic Aphid eggs is the same, *i. e.*, only one polar body is produced and there is no reduction of chromosomes. There is no mixture of male and female young in the offspring of one individual: certain apterous females produce only females, either winged or apterous, and others produce only winged males.

The ovarian oöcytes, eggs and polar bodies in the male line (Figs. 16, 17, 18) are noticeably larger than those figured in the female line (Figs. 1-12), but this may be due to the fact that the drawings were made from different species; the former from *Aphis ænotheræ*, the latter from *Aphis rosæ*. The difference is one of size not of structure, and much the best and most abundant male material was obtained from *Aphis ænotheræ*, where parthenogenetic reproduction was wholly replaced by the sexual method early in October, and young males of all ages were abundant.

<sup>1</sup>Male is used here merely in the sense that these eggs produce males.

## III. THE WINTER EGGS.

1. *Early Development and Growth.*

The material for study of the winter eggs was obtained by bringing into the laboratory rose twigs with broods of sexual females on the leaves. Adult males were usually found on the same leaves. These young females develop more rapidly in a warm room under glass, and soon begin to lay the fertilized eggs. The winged mothers of the sexual females were sectioned for the study of the ovaries of the sexual female embryos, and young sexual females for early stages in the development of the winter egg. Fig. 19 shows an ovary from such an embryo. It is considerably larger than the ovary of the ordinary parthenogenetic female embryo (Fig. 1), and in every case these ovaries show a large number of degenerating oöcytes at the posterior end (Fig. 19, *a*). These cells are more or less shriveled and stain deeply and irregularly. Whether this is simply degeneration of a large number—at least half—of the oöcytes of an ordinary parthenogenetic ovary in order that the remainder may have room for growth, or whether the parthenogenetic ovary may contain originally both eggs capable of parthenogenetic development and others capable of development only after fertilization, and the former degenerate in order that the latter may develop, I am unable to say. The number of oöcytes in the twelve parthenogenetic ovaries is certainly more than double the number of young ever produced by an individual, so that the latter supposition might be possible. Two cases observed in dissection, but never duplicated in fixed material, might support either view, and certainly tend to show that the ovary which produces parthenogenetic embryos and the ovary which produces winter eggs are originally identical. In two individuals egg-strings and winter ovaries with developing eggs were found associated in both groups of ovaries. The number in each varied—in one individual one group contained 5 egg-strings and one winter ovary, the other group 3 egg-strings and 3 winter ovaries; in the second individual each group contained 5 winter ovaries and one egg-string; on one side there was one parthenogenetic ovary with eggs and embryos (Fig. 20, *c* and *e*), on the other side was an egg-string consisting of two parthenogenetic embryos, a winter ovary and a young winter egg (Fig. 21, *a*, *b* and *e*). These individuals with mixed ovaries were found in

the greenhouse January 23, 1904, on a small rose bush which had lost its leaves and was nearly dead as a result of serving as a food plant for several generations of Aphids. They were the third generation from a winged female. Two or three others escaped dissection. Unfortunately only freehand sketches were made, and no other such cases were observed. One of these sketches is reproduced in Fig. 20 and a part of another in Fig. 21. Similar observations were recorded by Bonnet ('45) and by Leydig ('50), and Kyber ('15) observed sexual forms on the willow in June and on ripening grain in midsummer, but did not connect both parthenogenetic young and winter eggs with the same individual.

The oöcytes in the winter ovaries increase immensely in size before any eggs are given off, and the large nearly spherical ovaries are easily distinguished in dissections from the minute oval parthenogenetic ovaries (Fig. 20, *a* and *c*). The first egg is given off after the birth of the sexual female.

It is not my purpose to describe the growth period of the winter egg in detail. The nucleus, at first central, gradually moves to the periphery at one side, usually nearer the anterior end of the egg as it lies in the oviduct. When the egg has reached about one-half its ultimate size, yolk material from the vitellaria is taken in at the posterior end of the egg. There seems to be no such definite opening as in the case of the parthenogenetic embryo and of the egg of *Aleurodes*. Fig. 22 is an oblique section through an egg which plainly shows the relation between the yolk within and that without the egg. Entrance seems to be effected between any of the cells of the follicle epithelium, which is merely a part of the oviduct. Here again one wonders which is the active agent, the egg or the yolk cells, but it is impossible to tell. In the case of the embryo one is inclined to believe that it may actively suck in the yolk as the planarian embryo does, but there is nothing to indicate that the egg could have any such power. In the case of *Hydatina senta*, Linsen ('98) describes the yolk cells as penetrating the egg by their own activity. The entrance of yolk seems to be associated with a definite size of the ovum and would therefore occur at a definite point in the oviduct. The relation between the oviduct and the yolk gland may therefore be a more definite one than the sections show. Entrance of yolk must be effected very quickly as cases where the process can be demonstrated are very rare; and one

finds no such intermediate stages as would necessarily appear if this secondary yolk were formed within the egg as described by Balbiani ('69-'72). The outlines of the yolk cells are lost and only fragments of nuclei are found (Fig. 22), while in *Aleurodes* several whole yolk cells with nuclei intact enter the oviduct below the egg and are later included in the posterior end of the egg.

The chromatin in the egg during its growth period offers no favorable conditions for study. In earlier stages it does not take chromatin stains, and in later stages the chromosomes are spherical and mingled with nucleoli of similar form and staining qualities.

## 2. Maturation.

The earliest stage found in the laid egg was that shown in Fig. 23—the equatorial plate of the first polar spindle, showing 5 chromosomes, the reduced number, of the same relative form and size as the chromosomes of the 5 pairs in Figs. 7 and 12. The manner in which the egg chromosomes are paired is not evident, but the two divisions appear to be longitudinal and identical with the maturation divisions of the spermatocyte where it is quite certain that they are paired longitudinally, and probable that the first division separates the paired chromosomes.

Fig. 24 shows the first maturation spindle in metaphase. One chromosome appears in both figures (stippled in *b*). In Fig. 25 the first polar body and the second polar spindle in metaphase are figured. A part of a chromosome appears in *a* and parts of two in the spindle of *b*. In Fig. 26, a later stage is seen; the chromosomes of the first polar body are massed together, those of the second (not yet separated from the egg) show the comparative size relation of Fig. 23, their position indicating a longitudinal division; the chromatin of the egg nucleus is becoming diffuse and less stainable.

The spermatozoön enters at any point, more often near the posterior end of the egg, and leaves a train of cytoplasm behind it, as it traverses the yolk preceded by an aster. Fig. 27 shows the male and female pronuclei, the former distinguished by the cytoplasmic path (indicated by arrows). I have never found the first segmentation spindle in my material nor indeed the divisions immediately following, though the resting nuclei of these stages have frequently been observed. In the later segmentation stages

it is impossible to distinguish the individual chromosomes in the spindle; they are crowded together and often are so united in metaphase as to resemble a spireme in one plane.

#### IV. SPERMATOGENESIS.

Nearly all of the material for the study of the spermatogenesis was obtained from the *Ceanothera*. On the rose the young males are never met with in large numbers while on the *Ceanothera* an abundance of all sizes may often be found on the still-blossoming tips of the flower spikes, while the sexual females are scattered over the leaves and stalks. Here also were found a few mothers of the males. The few young males from the rose showed the same number and relative size of chromosomes.

The testes, as seen in dissections, have 6 lobes corresponding to the 6 ovaries in each group. The lobes are much larger than the ovaries, and as the spermatogonia are somewhat smaller than the oögonia, the number of mitoses leading to the spermatocyte must be several more than in the case of the oögonia. Only spermatogonial divisions are found in the embryos, and the last such division often, if not always, occurs after birth. Fig. 28 shows a resting spermatogonium; Figs. 29 and 30 spermatogonia just before division. In Fig. 30, 9 chromosomes of characteristic form and size can be recognized, one of the smallest not being visible. The equatorial plate, as also in most somatic mitoses, is too crowded for distinguishing either number or form of chromosomes.

The resting spermatocyte of the first order (Fig. 32) does not differ materially in appearance from the resting spermatogonium (Fig. 28) and indeed can often be recognized only by its relation to later stages. There is no evidence of so long a growth stage as in most forms. Closely associated with the first maturation mitosis and probably immediately preceding it are found the stages shown in Figs. 33 and 34. In Fig. 33, *a*, 8 of the 10 chromosomes are to be seen scattered through the nucleus; in *b*, *c* and *d*, chromosomes of the same form and size are seen paired longitudinally. Fig. 34 suggests the synapsis stage described for many insects. This stage is of much more frequent occurrence than that shown in Fig. 33, and appears to follow that, and immediately precede the first spermatocyte division which is shown in Figs. 35-39. Fig. 35, *a*, *b* and *c* show the 5 chromosomes in the equa-

torial plate of the first maturation spindle. All are connected by linin threads, and every possible arrangement of the 5 chromosomes is found in different cells. In *c* the longest chromosome is seen to be double and as a side view of the spindle in metaphase always shows the chromosomes double, it is probable that they come into the mitotic figure in that condition from the preceding conjugation stage. A second longitudinal split to form a tetrad cannot be detected at this stage. In Fig. 36, a side view and an oblique view of the equatorial plate show the double chromosomes. Two stages of the anaphase appear in Figs. 37 and 38. There is always one "lagging" chromosome in this division, and it certainly is not usually the longest, as I at first thought likely. In fact it appears in most cases to be either the second or third in size. After the two spermatocytes of the second order are fully formed, as shown in Fig. 39, the two daughter elements of this "lagging" chromosome are still connected by a thread extending through the cytoplasm of each cell. This phenomenon seems to be a peculiar characteristic of one of the chromosomes in this particular division. I have never seen an exception, nor have I ever seen anything similar in the second spermatocyte division or in fact in any other mitosis.

If, as I have supposed, this first maturation division simply separates paired chromosomes, it is possible that the pair that shows this peculiarity has a different linin connection from the others. In Fig. 35, it will be seen that the 5 chromosomes are united by linin threads into a chain with free ends. A side view (Fig. 36) shows two pairs connected by two parallel linin threads. Now if one of the end pairs always has its two elements connected by a single thread, we might expect such figures as 37, 38 and 39.

Fig. 40 is the equatorial plate of the second maturation mitosis, showing again the 5 chromosomes of characteristic form and size. Fig. 41 shows one of a few fortunate sections showing the daughter chromosomes in anaphase, and removing all doubt as to the kind of division, longitudinal or transverse.

Judging from analogy in other insects, I fully expected to find one longitudinal and one transverse division, but was soon convinced that both are longitudinal, and from such figures as 23 and 26 that the same is true in the maturation division of the winter egg. This point will be more fully discussed later.



The chromosomes retain their individuality in the spermatids for some time, but finally become massed together to form the sperm-head (Fig. 42). The development of the spermatozoon from the spermatid appears to be very simple, the head being formed mainly from the chromatin and the long, rather thick tail from the cytoplasm. None of the accessory structures described for other insects are present. No centrosome has been detected in any mitosis, and asters have been seen only in connection with the sperm-nucleus in the egg, the pronuclei, and the segmentation spindles of the winter egg. There is no trace of anything that could be called an "accessory chromosome" (McClung, '02). The nucleolus appears to be of the same character throughout, appearing in resting cells and disappearing in mitosis. That it is not a chromatin nucleolus, or karyosome, is shown by the fact that the chromosomes in many cases are visible before it disappears (Fig. 29) and with the Delafield-orange combination the nucleolus invariably takes the orange stain while the nuclear reticulum stains with the hæmatoxylin.

#### V. GENERAL DISCUSSION.

##### 1. *Mendel's Law, and the Individuality of the Chromosomes.*

It appears that in the Aphids studied there is a series of 5 chromosomes of different shape and size in the germ cells of the sexual generation: the maternal or egg-series is exactly equivalent to the paternal or sperm-series. The chromosomes show the same relative form and size throughout the maturation divisions. The two series of chromosomes meet in fertilization, and throughout the parthenogenetic generations, both female and male, we find the double series, 10 chromosomes of five different sizes. In the spermatocytes, and presumably in the oöcytes, the chromosomes of the double series are paired, and in one of the maturation divisions, apparently the first, the paired chromosomes are separated. Supposing that the different chromosomes have different physiological values, or represent different hereditary characters, as maintained by Boveri ('02), we find in the behavior of the chromosomes in the germ cells of the Aphid exactly the conditions required by Mendel's Law of Heredity. The characters represented by the 5 constantly different chromosomes would be segregated at

each recurrence of sexual reproduction, giving germ cells pure with respect to each of the 5 different characters or sets of correlated characters represented by the five chromosomes. During the whole series of parthenogenetic generations the same paternal and maternal series of chromosomes is maintained by longitudinal division, there is no amphimixis and no apparent chance for variation unless it be a change in dominance of certain characters, due to external conditions; for example, the winged-character and the sex-character.

The constant recurrence of this single or double series of chromosomes of the same relative form and size, is one point more in support of the hypothesis of the individuality of the chromosomes, strongly advocated by Rabl ('85) and Boveri ('87, '88, '91, '02). Recent papers by Sutton ('02) on *Brachystola* and Baumgartner ('04) on *Gryllus* show similar form and size relations of chromosomes; but in the Aphid one has the advantage of working with a smaller number, where each individual chromosome can be distinguished from all others of the series appearing in a winter egg or a spermatocyte.

## 2. *Maturation of Parthenogenetic Eggs.*

In comparing the results of various authors on this subject, one meets with great variations in different parthenogenetic forms. In the drone bee (Blochmann, '88-'89) two polar bodies are found, and Petrunkewitsch ('01) states that reduction occurs in the second maturation division, the normal number of chromosomes probably being restored by a subsequent longitudinal splitting of the chromosomes without mitosis. In *Liparis dispar*, *Bombyx mori* and *Ocneria dispar* (Platner, '88-'89, Henking, '92), two polar bodies are given off by the occasional parthenogenetic eggs and both sexes are produced. Weismann ('91), in attempting to bring these cases into line with his views of maturation and fertilization, says, "The nucleoplasm of certain eggs possesses a greater power of growth than that of a majority of the eggs of the same species, while in the case of the bee every ovum possesses a power of growth sufficient to double its nuclear substance." Petrunkewitsch's explanation of the presence of the normal number of chromosomes in somatic cells of the male bee sounds more like an echo of Weismann's argument than like the result of actual observation.

In *Rhodites rosæ* (Henking) there are two maturation divisions but no reduction of chromosomes in eggs that produce females. Males are rare and the maturation of the male egg is not known. In *Artemia salina* (Brauer, '94) either one polar body only is formed, or a second division occurs and the resulting nucleus conjugates with the egg nucleus. Here again the female and male generations seem not to have been distinguished.

Weismann and Ischikawa ('88) found only one polar body in the parthenogenetic eggs of several rotifers and crustaceans, no statement being made in regard to the male generations. Mrazek ('97), and Erlanger and Lauterborn ('97) found that in *Asplanchna*, a rotifer, the parthenogenetic female eggs gave off one polar body, while the parthenogenetic male eggs formed two, and there was no indication of a union of the second polar body with the egg nucleus.

In *Hydatina senta* (Lenssen, '98) the first maturation division in parthenogenetic female eggs goes only as far as the metaphase; there is no reduction, and the chromosomes (10 or 12) fuse to form the egg nucleus. In the male egg reduction occurs, 5 or 6 chromosomes appearing in the polar plates of the spindle. In *Hydatina* it is supposed that the first maturation division is suppressed in both the parthenogenetic and the sexual eggs. In the Aphid only one polar body is given off in the parthenogenetic egg—male or female—and there is no evidence of reduction in either male or female parthenogenetic egg.

Thus we find a series, beginning with forms where parthenogenesis is either occasional or continues for only one generation, when maturation appears to follow the usual course for fertilized eggs; and ending with *Hydatina senta* where the whole process is practically suppressed in the parthenogenetic female eggs, and the Aphid where one maturation division without reduction remains in both male and female parthenogenetic eggs. We are thus led to question the importance of the second polar body in determining the male sex, also to question the view that parthenogenesis is due to the suppression of one or both maturation divisions, and to suggest that the various degrees of suppression of maturation phenomena in parthenogenetic eggs may be a more or less simple and perfect adaptation to a necessity of continued parthenogenetic reproduction, *i. e.*, the retention of the full double series of maternal and paternal chromosomes throughout the parthenogenetic

portion of the cycle. The whole subject needs further investigation from the standpoint of the determination of sex.

### 3. *Determination of Sex.*

As the male sex cells of the Aphid contain no "accessory chromosome," McClung's theory of sex-determination need not be discussed in this connection. The question naturally arises whether the "accessory chromosome" is to be found in any of the parthenogenetic insects or crustaceans.

Castle ('03) in his recent paper on "The Heredity of Sex" attempts to place the sex-character in the same category with other hereditary characters and to apply to it the principles of Mendel's Law of Heredity—dominance and segregation. He says on page 198, "A study of sex-heredity in parthenogenetic animals shows (1) that in such animals the female character uniformly dominates over the male whenever the two are present together," and on page 199, "With a single exception, we know that in uninterrupted parthenogenetic reproduction, as it occurs in the Daphnidæ and Rotiferæ at certain seasons, the parthenogenetic egg forms only one polar cell, and the animal developing from such an egg is invariably female, or more correctly ♂ (♀), the male character being recessive," and further on, "At the return to sexual reproduction, the parthenogenetic mother produces eggs which form a second polar cell, and from such eggs only males develop. It is clear, then, that in the second maturation division the female character has been eliminated from the egg, for were it still there, it must from its nature dominate."

As an exception Castle cites *Rhodites rosæ*, in which according to Henking the parthenogenetic eggs produce two polar bodies, but no reduction occurs, and therefore no segregation of sex characters. Castle assumes that the occasional egg which produces a male, does, in some way, eliminate the female character. *Hydatina senta* is also cited: according to Lenssen ('98) no polar body is formed and there is no reduction in the female egg, while in the male egg one maturation division occurs with reduction. Castle supposes in the latter case that the first maturation division is regularly suppressed as Sobotta ('99) has found to be the case in the mouse.

In the Aphid only one polar body is formed in the female and

also in the male parthenogenetic egg, and there is no reduction of chromosomes in either case. If the sex character resides in one of the chromosomes, it is certainly not eliminated from the male egg. How shall we harmonize the conditions in the Aphid with Castle's theory? We cannot argue as he does for *Bombyx mori*, *Ocneria dispar* and all normally diœcious animals that there is no uniform dominance of one sex over the other. How then shall we account for the appearance of males, if all parthenogenetic Aphids are sex-hybrids with the female character usually dominant? The only possible argument seems to be that certain favorable conditions (warmth and abundant food) determine that the female sex-character shall continue dominant, the male sex-character recessive; while certain other conditions (not yet definitely determined) cause the male sex-character to become dominant and the female character recessive. A similar change in dominance may be imagined to account for the presence or absence of wings in both the parthenogenetic and the sexual generations. According to this theory we must suppose all of the oögonia to be alike in their hereditary characters—all sex-hybrids as well as hybrids in respect to other maternal and paternal characters. In addition, we must suppose that in parthenogenetic eggs, which undergo no reduction, dominance of certain characters can be reversed by external circumstances. This may of course occur at a very early stage in the history of the germ-cells, making the eggs at the time of maturation virtually male or female.

The case cited of two Aphids, each containing both parthenogenetic and winter ovaries (Fig. 20), and also showing that a parthenogenetic ovary may, after giving off parthenogenetic eggs, change to a winter ovary, the sexual form, is strong evidence that the ovarian oöcytes of the Aphid may be affected by external conditions. Whether the degeneration of certain oöcytes in all ovaries which are to produce winter eggs, can be considered evidence that there are two kinds of eggs, those that produce parthenogenetic young and those that require fertilization in order that they may develop, is not clear.

Beard ('02) says, in discussing parthenogenesis, "When in a parthenogenetic form, a long series of one sex appears, the eggs of the other sex must have been either delayed or suppressed." According to Beard's theory we must suppose that in the Aphid there are both male and female eggs, or at least such germ-cells,

produced, and that all the male eggs are suppressed in the female generations while all the female eggs are suppressed in the male generations. There is no histological evidence of any such degeneration of the germ-cells.

In trying to fit the Mendelian theory of dominance, as elaborated by Castle, to the sex-conditions in Aphids, we meet with a peculiar contradiction in the fact that the same external conditions lead to the production of males and of sexual females. On the *Oenothera* this condition is very conspicuous, for in the autumn parthenogenetic reproduction is completely changed over into the sexual method of reproduction. Certain apterous individuals are producing male offspring, and at the same time or slightly earlier other winged individuals are producing the winter egg-layers. Three generations at least are involved in the winter egg production—an apterous generation followed by a winged generation and that by the apterous sexual females. In the case of the males only two generations are necessarily involved, an apterous generation and the generation of winged males. The food conditions which probably lead to the change in method of reproduction, may therefore differ in degree, the earlier conditions starting the sexual female line, and later conditions the male line. In favor of this argument is the fact that on the rose a scattered generation of sexual females is often met with before there are any males and before the regular female sexual generation appears.

It is perfectly evident that histological study of the germ-cells combined with observation of the living insects has not settled the question of sex-determination in the Aphid, but it has, in a way, cleared the field for interpretation of the results of experiment. We know (1) that there is no "accessory chromosome," and (2) that the formation of a second polar body with reduction of chromosomes does not occur in the male generation.

In the discussion of sex-determination by Cuénot ('99), Beard ('02), O. Schultze ('02), and Lenhossek ('03) we find that the evidence is overwhelmingly on the side of the view that sex is determined in the egg; but to the question how sex is determined in the egg, no thoroughly convincing answer has yet been given.

V. SUMMARY OF RESULTS.

1. There is no reduction in the number of chromosomes in the female parthenogenetic egg.

2. The 10 chromosomes form 5 pairs of different form and size.

3. The polar body, at first extruded from the egg, later becomes sunken in the cytoplasm, but takes no part in the development of the embryo.

4. The early segmentations are nuclear only, cell walls coming in at a later stage.

5. The young embryo takes in yolk material (the *secundäre Dotter*) from the vitellaria, through a definite valvular opening in the oviduct.

6. In the maturation of male eggs only one polar body is given off, and there is no reduction in the number of chromosomes.

7. The offspring of one parthenogenetic female are either all females or all males.

8. The ovaries of the parthenogenetic and of the sexual females may be originally identical in structure, as shown (1) by the presence of both kinds of ovaries in the same individuals; (2) by the degeneration of about half of the oöcytes in the posterior half of the ovary of the sexual female embryo. The significance of the latter phenomenon is uncertain.

9. The reduced number of chromosomes appears in the polar spindles of the winter eggs, and both divisions are longitudinal.

10. The somatic number of chromosomes appears in the spermatogonia.

11. Reduction in the spermatocytes is effected by longitudinal pairing of the chromosomes immediately before the first maturation mitosis.

12. The first maturation division probably separates paired chromosomes and the second is a longitudinal division of the original univalent chromosomes.

13. The delay in separation of one pair of chromosomes in the first maturation division is probably due to a different linin connection from the others, rather than to any physiological peculiarity.

14. There is no "accessory chromosome" in the male germ-cells of aphids.

## LITERATURE.

- BALBIANI, E. G., '69-'72.—Mémoire sur la génération des aphides. *Ann. Sc. Nat. Ser. 5, Zool. T. 11, 1869; T. 14, 1870; T. 15, 1872.*
- BAUMGARTNER, W. J., '04.—Some new Evidence for the Individuality of the Chromosomes. *Biol. Bull. vol. viii, No. 1.*
- BEARD, J., '02.—The Determination of Sex in Animal Development. *Zool. Jahrb. vol. xvi.*
- BLOCHMANN, F., '87.—Ueber die Richtungskörper bei Insekteneiern. *Morph. Jahrb. vol. xii.*
- '88.—Ueber die Richtungskörper bei unbefruchtet sich entwickelnden Insekteneiern. *Verh. naturh. med. Ver. Heidelberg, N. F., vol. iv, No. 2.*
- BONNET, CH., '45.—Traité d'Insectologie ou observations sur quelques espèces de Vers d'eau douce et sur les Pucerons. Paris. Durand.
- BOVERI, TH., '87.—Ueber Differenzierung der Zellkerne während der Furchung des Eies von *Ascaris meg.* *Anat. Anz., vol. ii.*
- '88.—Zellenstudien II. *Jena Zeitschr., vol. xxii.*
- '91.—Befruchtung. *Merkel u. Bonnet's Ergebnisse, vol. i.*
- '02.—Ueber mehrpolige Mitosen als Mittel zur Analyse des Zellkerns. *Verh. d. phys.-med. Ges. Würzburg. N. F., Bd. xxxv.*
- BRAUER, A., '94.—Zur Kenntniss der Reifung des parthenogenetisch sich entwickelnden Eies von *Artemia salina.* *Arch. mikr. Anat., vol. xi.*
- CASTLE, W. E., '03.—The Heredity of Sex. *Bull. of the Mus. of Comp. Zoöl. Harvard College, vol. xl, No. 4.*
- CUÉNOT, L., '99.—Sur la détermination du sexe chez les animaux. *Bull. Sci. Fr. Belgique, vol. xxxii.*
- ERLANGER U. LAUTERBORN, '97.—Ueber die ersten Entwicklungsvorgänge im parthenogenetischen und befruchteten Räderthierei. *Zool. Anz., vol. xx.*
- HENKING, H., '92.—Untersuchungen über die ersten Entwickelungsvorgänge in den Eiern der Insekten. *Zeit. wiss. Zool., vol. liv.*
- KYBER, J. F., '15.—Einige Erfahrungen und Bemerkungen über Blattläuse. *Germar's Magazin der Entomologie, t. 1-2c.*
- LENHOSSEK, M. v., '03.—Das Problem der geschlechtsbestimmenden Ursachen. *Jena. Fischer.*
- LENSSSEN, J., '98.—Contribution à l'étude du développement et de la maturation des oeufs chez *Hydatina senta.* *La Cellule, vol. xiv.*
- LEYDIG, T., '50.—Einige Bemerkungen über die Entwicklung der Blattläuse. *Zeit. wiss. Zool., vol. ii.*



- McCLUNG, C. E., '02.—The Accessory Chromosome—Sex-Determinant? *Biol. Bull.*, vol. vii, Nos. 1 and 2.
- MRAZEK, AL., '97.—Zur Embryonalentwicklung des Gattung *Asplanchna*. *Jahresb. böhna Ges.*, vol. ii.
- PETRUNKEWITSCH, A., '01.—Die Richtungskörper und ihr Schicksal im befruchteten und unbefruchteten Bienenei. *Zool. Jahrb.*, vol. xiv.
- PLATNER, G., '88.—Die erste Entwicklung befruchteter und parthenogenetischer Eier von *Liparis dispar*. *Biol. Centralbl.*, vol. viii, No. 17.
- '89.—Ueber die Bedeutung der Richtungskörperchen. *Biol. Centralbl.*, vol. 8.
- RABL, C., '85.—Ueber Zellteilung. *Morph. Jahrb.*, vol. x.
- SCHULTZE, O., '02.—Was lehren uns Beobachtung und Experiment über die Ursache männliche und weibliche Geschlechtsbildung bei Tieren und Pflanzen? *Sitz. ber. der phys.-med. Ges. Würzburg*. 1902.
- SOBOTTA, J., '99.—Ueber die Bedeutung der mitotischen Figuren in den Eierstockeiern der Säugetiere. *Festschr. phys.-med. Ges. Würzburg*. 1889.
- SUTTON, W. S., '02.—On the Morphology of the Chromosome Group in *Brachystola magna*. *Biol. Bulletin*, vol. iv, No. 1.
- WEISMANN, A., '63.—Die Entwicklung der Diptera im Ei. *Zeit. wiss. Zool.*, vol. xiii.
- '92.—*Essays on Heredity*. Vol. ii. Oxford. 1892, p. 174.
- WEISMANN AND ISCHIKAWA, '88.—Weitere Untersuchungen zum Zahlengesetz der Richtungskörper. *Zool. Jahrb.*, vol. iii.
- WILL, L., '83.—Zur Bildung des Eies und Blastoderms bei der viviparen Aphiden. *Arb. Zool. Zoot. Inst. Würzburg*. Vol. vi.
- '88.—Zur Entwicklungsgeschichte der viviparen Aphiden. *Biol. Centralbl.*, vol. viii, No. 5.
- '89.—Entwicklungsgeschichte der viviparen Aphiden. *Zool. Jahrb.*, vol. iii.
- WITLACZIL, EM., '84.—Entwicklungsgeschichte der Aphiden. *Zeit. wiss. Zool.*, vol. xl.

## DESCRIPTION OF PLATES.

With the exception of Figs. 20 and 21, the figures are all camera drawings, made with Zeiss obj. 2 mm., oc. 8, except Figs. 1, 14, 15 and 19, which were drawn with Zeiss obj. 2 mm., oc. 4, and Fig. 22, for which Zeiss obj. D, oc. 4 was used. Plates II and III have been reduced one-tenth.

## PLATE I.

- Fig. 1. Parthenogenetic ovary from an embryo of *Aphis rosæ*. *a* = a developing ovum. *b* = stalk of the next ovum in the egg-string.
- Fig. 2. Oöcyte from above ovary.
- Fig. 3. Oöcytes at the beginning of their growth period, showing chromosomes but no nucleolus.
- Figs. 4-6. Later growth stages of the oöcyte.
- Fig. 7. Equatorial plate of the polar spindle, showing 10 chromosomes of 5 different sizes and shapes *a-e*.
- Fig. 8. Polar spindle in anaphase. Polar body already separated from the egg.
- Fig. 9. A later stage, showing the polar body (*p*), and the egg-nucleus (*n*).
- Fig. 10. An egg containing the first segmentation spindle, and the polar body (*p*) somewhat sunken in the cytoplasm of the egg.
- Fig. 11. Segmentation stage with resting nuclei and polar body (*p*) lying in a vacuole in the cytoplasm of the unsegmented egg.
- Fig. 12. Segmentation stage, showing polar body (*p*) and mitotic figures. The chromosomes of the equatorial plate are lettered *a-e* to correspond to those of the equatorial plate of the polar spindle in Fig. 7.

## PLATE II.

- Fig. 13. Later segmentation stage, showing polar body (*p*) probably degenerating.
- Fig. 14. Young parthenogenetic embryo just beginning to take in yolk (*a*) through a valvular opening in the oviduct (*b*).
- Fig. 15. A slightly later stage of the same process.
- Fig. 16. Resting oöcyte from an ovary of *Aphis ænotheræ*, all the embryos male.
- Fig. 17. Section of a segmenting egg from an individual containing male embryos, showing one polar body (*p*).
- Fig. 18. Part of a section similar to the above, showing chromosomes not so completely fused.
- Fig. 19. Ovary from a female embryo of the sexual generation, showing degenerating oöcytes (*a*).
- Fig. 20. Freehand sketch of a mixed group of ovaries, consisting of five winter ovaries (*a*) with winter eggs (*b*), and one parthenogenetic ovary (*c*) with developing eggs and embryos (*e*).
- Fig. 21. Freehand sketch of egg-string from the other side of the same individual, showing two parthenogenetic embryos (*e*), a winter egg (*b*) and a winter ovary (*a*).

## PLATE III.

- Fig. 22. Oblique section of a winter egg, showing entrance of secondary yolk from without. *a* = yolk cell (nucleus in next section). *b* and *c* = fragments of nuclei.
- Fig. 23. Equatorial plate of first polar spindle in winter egg of *Aphis rosæ*. The five chromosomes are lettered *a-e* corresponding to the five pairs in Figs. 7 and 12.
- Fig. 24. First polar spindle, metaphase. The stippled chromosome is a part of one which appears in *a*.

Fig. 25. First polar body ( $p^1$ ) containing five chromosomes, and second polar spindle. Two chromosomes appear in two sections  $b$  and  $c$ , and a part of one belonging to the first polar body is seen in section  $a$ .

Fig. 26. First polar body ( $p^1$ ); chromosomes of second polar body ( $p^2$ ); and female pronucleus forming ( $n$ ).

Fig. 27. Male and female pronuclei. The arrows indicate the path of the sperm nucleus.

PLATE IV.

Fig. 28. Resting spermatogonium of *Aphis ænothoræ*.

Fig. 29. Spermatogonia preparing for mitosis, showing both nucleolus and chromosomes.

Fig. 30. Spermatogonium showing 9 of the 10 chromosomes, and no nucleolus.

Fig. 31. Equatorial plate of spermatogonial mitosis.

Fig. 32. Spermatocyte of first order in resting stage.

Fig. 33. Spermatocytes of first order, showing ( $a$ ) eight of the ten chromosomes not paired and ( $b, c, d$ ) chromosomes of the same size in pairs.

Fig. 34. Spermatocytes before division, possibly a "synapsis" stage.

Fig. 35. Equatorial plate of first maturation mitosis, showing variations in arrangement of chromosomes ( $a, b, c$ ), and double chromosomes, ( $c$ ) chromosomes lettered as in Figs. 7, 12 and 23.

Fig. 36. Side view and oblique view of equatorial plate of first maturation mitosis showing double chromosomes.

Fig. 37. Anaphase of first maturation mitosis showing "lagging" chromosome.

Fig. 38. Later stage of the same.

Fig. 39. A pair of spermatocytes of the second order in a partial resting stage, the lagging chromosomes still connected.

Fig. 40. Equatorial plate of second maturation mitosis, chromosomes lettered as in Figs. 7, 12, 23 and 35.

Fig. 41. Anaphase of second maturation mitosis.

Fig. 42. Spermatids in various stages.



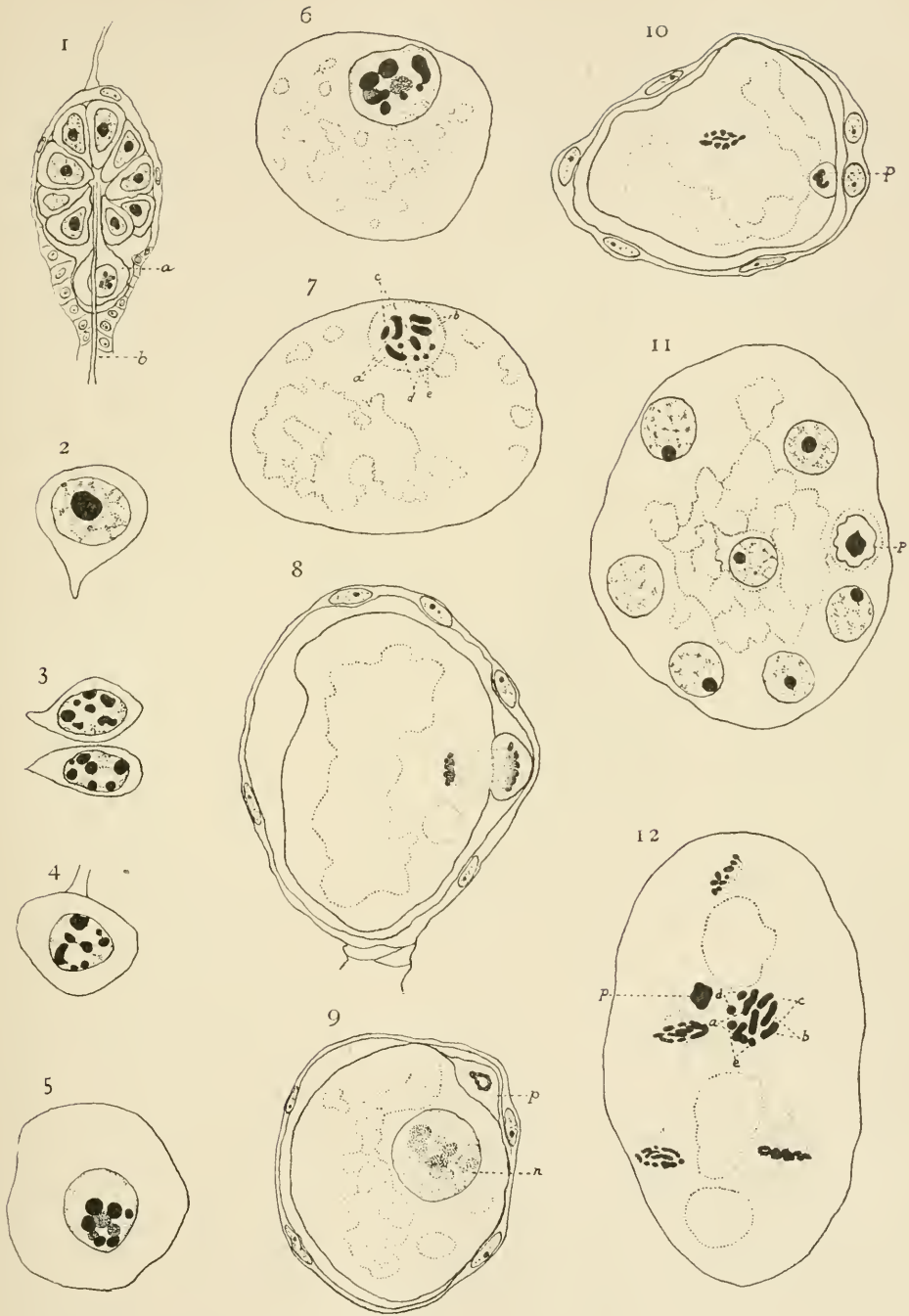

N. M. S. del.



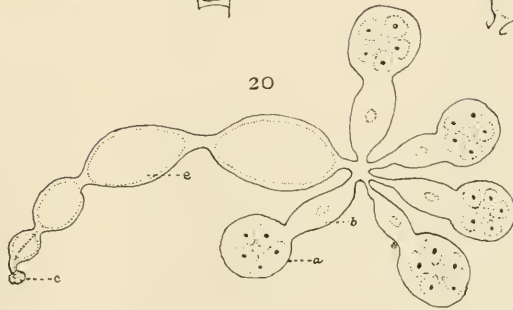
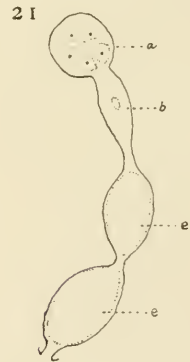
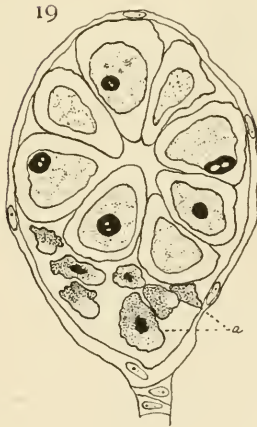
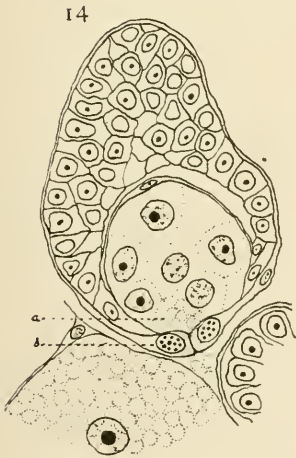
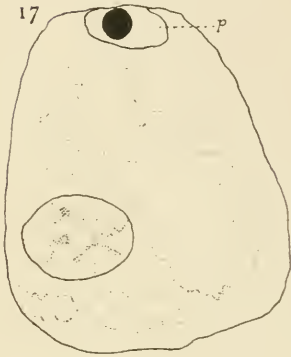
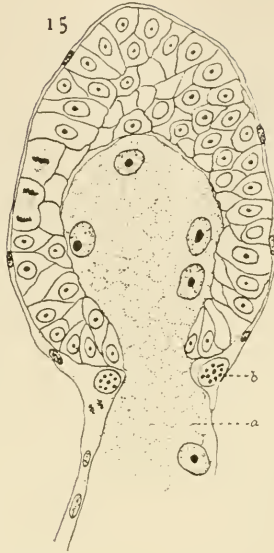
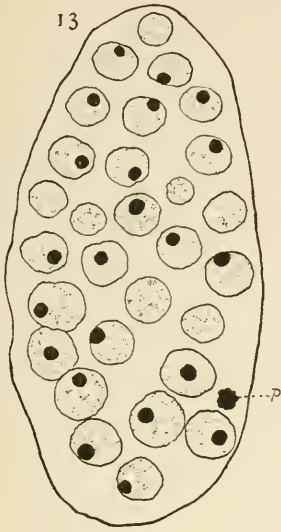

N. M. S. del.





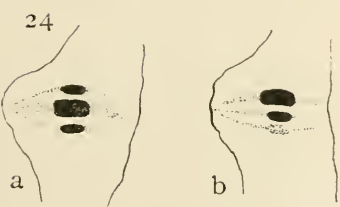
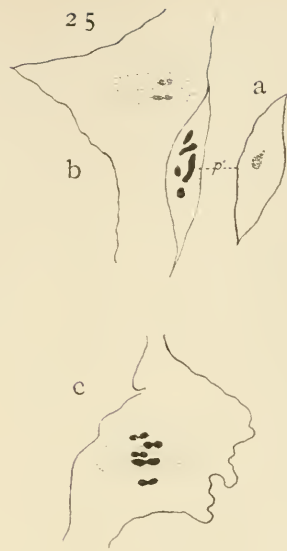
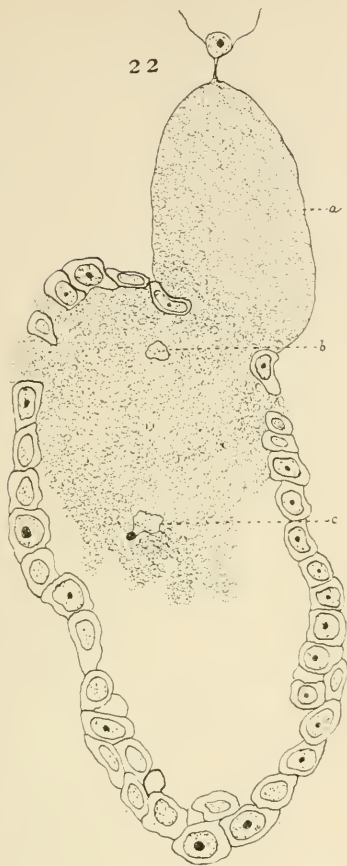

N. M. S. del.



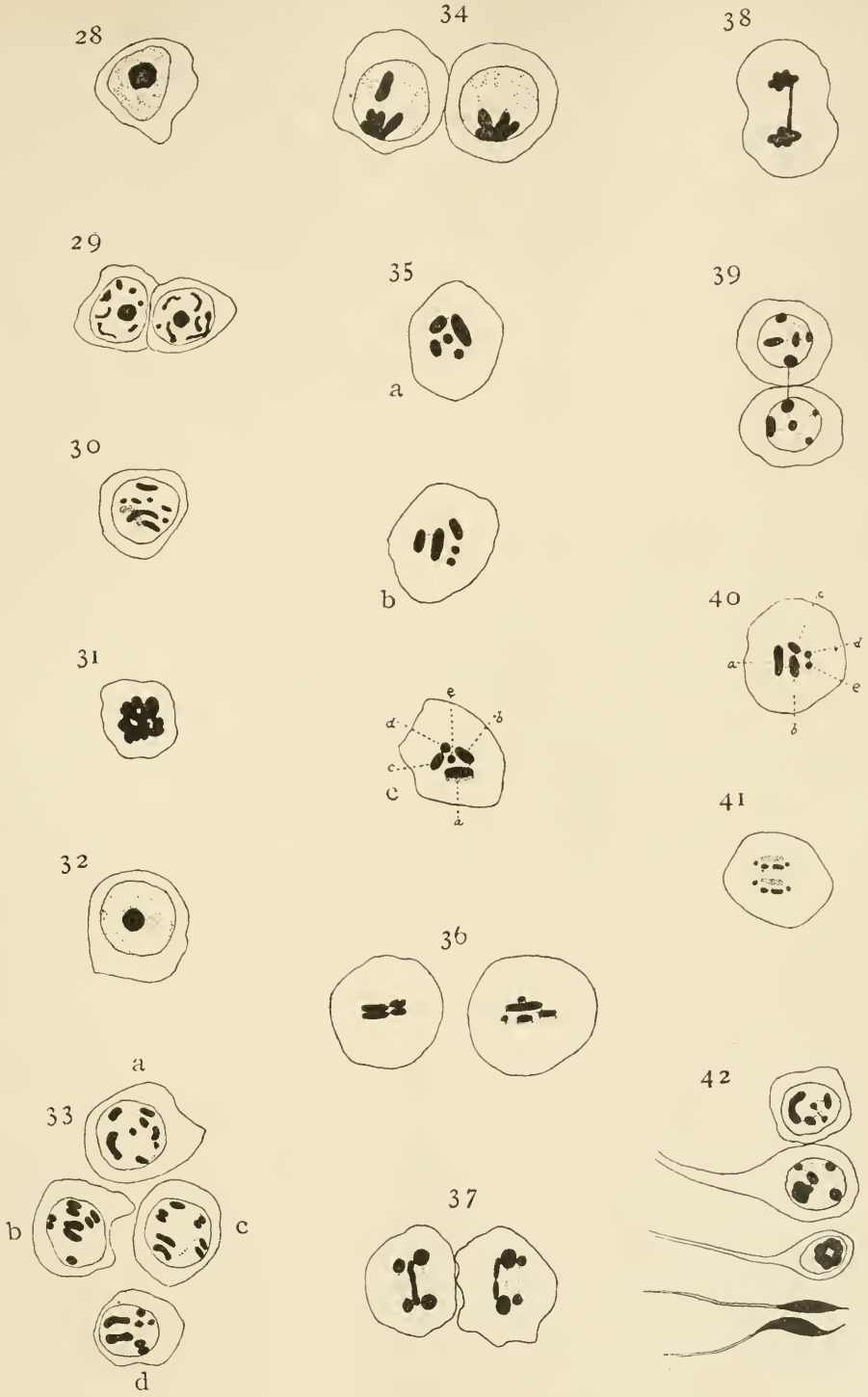

N. M. S. del.



# REGENERATION IN POLYCHÆRUS CAUDATUS.

BY

N. M. STEVENS AND A. M. BORING.

## PART I. OBSERVATIONS ON LIVING MATERIAL.

BY

N. M. STEVENS.

WITH 21 FIGURES.

While enjoying the hospitality of the Hopkins Seaside Laboratory at Pacific Grove, Cal., the past summer, I made a few experiments to test the powers of regeneration of the red acœlous flat-worm, *Polychærus caudatus*, which abounds there in shallow tide-pools on the underside of stones and shells and on *Ulva*. The object of the experiments was a comparison of the regeneration of this form which has no definitely differentiated organs—eyes, central nervous system, pharynx, etc.—with the more highly organized fresh-water Planarians, as well as with the results of Schultz ('02) and Child ('04) on *Leptoplana* and other marine forms which show very incomplete anterior regeneration.

### *Method.*

In most of the experiments, the worms were cut into three nearly equal parts as in Fig. A, *a—b*, *c—d*. These parts will be spoken of as head-pieces, middle-pieces and tail-pieces. The material was kept in covered glass dishes, somewhat shaded, and the sea-water was changed morning and evening.

Regeneration in general was much slower than in fresh-water Planarians. The animals are very sluggish normally, and the pieces moved but little even when disturbed by changing the water, the head-pieces, however, being much more active than the middle-pieces and tail-pieces. The tail-pieces continued to deposit eggs for several days as freely as did the entire worms, and the eggs developed normally.

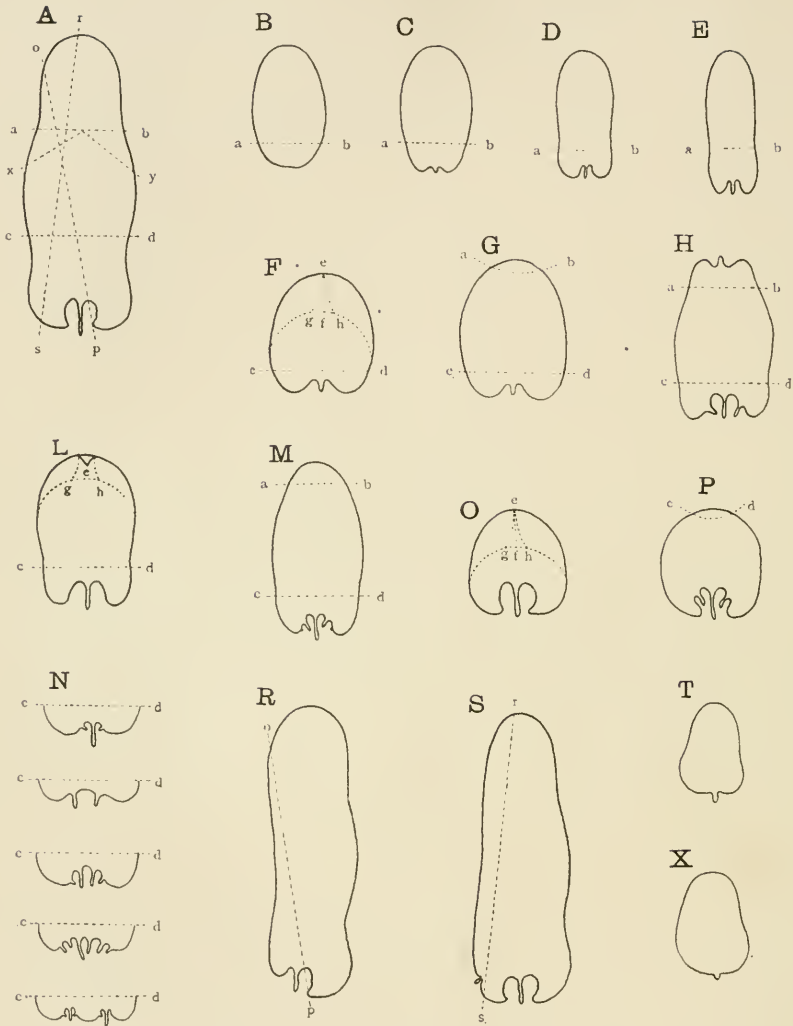

A.—Whole worm showing planes of section. B—D.—Head-pieces after 2 weeks' regeneration. E.—Head-piece after 4 weeks' regeneration. F.—Middle-piece after 2 weeks, showing ventral union of anterior edges ( $e-f$ ), V of new tissue ( $g-e-h$ ), and posterior regeneration. G.—Middle-piece after 2 weeks, showing anterior regeneration where the edges have not united as in F. H.—Middle-piece after 19 days, showing heteromorphic tail. L.—Middle-piece after 4 weeks, showing more advanced anterior regeneration of the type shown in F. M.—Middle-piece after 4 weeks, showing anterior regeneration of the type shown in G. N.—Posterior regeneration of middle-pieces, showing supernumerary appendages. O—P.—Regeneration in tail-pieces, 2 weeks. R—S.—Lateral regeneration, 4 weeks. T—X.—Young worms, still in jelly, with appendages just developing.

*Head-pieces.*

These pieces very soon began to produce new tissue at the cut surface as in other Planarians. Among the 40-50 pieces in a series, at the end of two weeks, the stages of posterior regeneration shown in Figs. B, C and D were found with all intermediate stages. A rounded mass of new tissue of considerable size forms posterior to the cut surface, *a-b*, before the characteristic notch and appendage appear. Continued regeneration adds to the length of the new part while the old part decreases in width and the whole piece gradually assumes the typical form. The notch, at first broad and shallow, becomes deeper and narrower, and the appendage longer. The new part assumes the characteristic pigmentation of the adult tail-region, and a digestive region forms anterior to the line of section, *a-b*. Regeneration of these pieces was not followed longer than four weeks, when most of the pieces had assumed the form shown in Fig. E, where, if one compares with Figs. A and B, morphallaxis is very apparent.

*Middle-pieces.*

In these pieces posterior regeneration proceeded somewhat differently. New tissue appeared along the whole of the cut surface, but was so distributed as to form a median notch from a very early stage. One or more appendages appeared earlier than in the regeneration of head-pieces. Figs. F and G show the usual amount of posterior regeneration after two weeks, and Figs. H, L, M and N after four weeks. In all of these pieces the notch is still much broader and more widely open than in the typical form A. The multiple appendages shown in the figures were at first thought to be a peculiarity connected with regeneration; but examination of many normal worms showed that, though one appendage is the typical structure, still all the variations observed in regeneration are to be found in normal adult worms. These variations are, however, far more frequent in regeneration, and more frequent in middle-pieces than in head-pieces, where, as a rule, only one appendage develops. These observations suggested a comparison with the formation of the tail-region in the embryo. Figs. T and X show two young worms, ten to twelve days after the eggs were laid, and still in the jelly which enveloped the eggs. The appendage has appeared but not the characteristic

notch. Posterior regeneration in head-pieces (Figs. B and C) follows more nearly the embryonic method of tail development than does that of middle-pieces, where regeneration from the beginning seems to be based on the adult form of the tail-region which has been removed.

Anterior regeneration varied greatly in different lots of material and in different pieces of the same series. There are, however, two distinct types. In most cases the cut anterior end, *a—b*, folded together ventrally and the portions on either side of the median line united as shown in Fig. F, *e—f*. In the first set of pieces no anterior regeneration occurred while the material was under observation. In another set, in which all the pieces regenerated better, a few at the end of two weeks showed a V of new tissue between the united cut edges, Fig. F, *g—e—b*. At the end of four weeks such pieces had developed as in Fig. L, *g—e—b*, and later some of them produced typical worms. As the union of the cut edges, as in Fig. F, *e—f*, appeared to hinder regeneration in many cases, an attempt was made to prevent the union of the edges or to remove the hindrance later on. Pieces were cut as in Fig. A, *x—y*, or with a sharper angle, but the cut edges still curled under and united as before. Cutting the line of union was equally unsuccessful. There were a few pieces which contracted at the anterior end without folding under and uniting; these regenerated as shown in Figs. G and M, and in due time produced worms of typical form. Anterior regeneration was, however, in all cases less rapid than posterior. One piece produced a heteromorphic tail, Fig. H. This individual did not crawl normally, but half crawled, half swam with great difficulty on its back or side. This was the only case of heteromorphosis observed.

#### *Tail-pieces.*

Anterior regeneration of tail-pieces was of the two general types described for middle-pieces and illustrated in Figs. O and P. In general it was less rapid and less complete than in middle-pieces.

#### *Lateral Regeneration.*

A few worms were cut longitudinally in various ways. Regeneration occurred along the whole cut surface as in other forms, the new material being distributed in proportion to the amount



removed. Figs. R and S show the result in two cases of diagonal section, as in Fig. A,  $\sigma-p$ , and  $r-s$ , after four weeks. In Fig. R the posterior end on the regenerating side is in approximately the same condition as in cases of entire posterior regeneration. In Fig. S, an abnormal notch and appendage has developed near  $s$ , as though the notch and appendage were a necessary accompaniment of posterior regeneration without regard to the presence of the same structure in the old part. This phenomenon also recalls the supplementary heads and tails described by Morgan ('01) and others, as appearing on long obliquely or longitudinally cut surfaces.

### *General Discussion.*

The results of the experiments show that in *Polychærus caudatus* anterior regeneration at different levels may proceed much as in many fresh-water forms (Figs. G, M and P), or it may be prevented or delayed, not by muscular contraction and union of the muscle bands, as described by Schultz ('02), but by a folding under and union of the cut edges. (Fig. F,  $e-f$ .) That such union of the cut edges is not an insuperable hindrance to regeneration in this form is proved by such cases as are shown in Figs. F, L and O, where regeneration begins with the formation of a V of new tissue and ends with the production of a typical head-region.

In *Polychærus* there is no axial gut (Bardeen, '01), nor is there a central nervous system to influence regeneration (Lillie, '00; Child, '04). The fact that head-pieces, which are more active, regenerate more rapidly than middle-pieces or tail-pieces, might be held to support Child's theory that "there is a close parallelism between the rapidity, amount and completeness of regeneration and the characteristic activity of the part concerned;" but the difference in rate of regeneration and morphallaxis is not proportionate to the difference in activity, for head-pieces are easily stimulated into activity by changing the water or jarring the dish, while middle-pieces and tail-pieces hardly move at all during the first two weeks unless violently disturbed. The difference in activity is great, while the difference in rate of regeneration is comparatively small.

So far as regeneration in *Polychærus* has been tested by these experiments, it seems to be largely a question of "organization"

and "totipotence" of material (Morgan, '04) modified in many cases by the folding under and uniting of the anterior cut surfaces.

It is the intention of the authors to supplement this work with further experiments during the coming summer.

## PART II. HISTOLOGY.

BY

A. M. BORING.

WITH 2 PLATES AND 1 FIGURE IN THE TEXT.

After working on the external features of the regeneration of *Polychærus caudatus* in California during the past summer, Miss Stevens brought back to Bryn Mawr some preserved material—the whole flatworms and pieces that had regenerated for varying lengths of time. The simplicity of structure and the lack of any great differentiation of tissue, made it a matter of interest to work out the histological side of the regeneration of this form, in order to see whether it differs in any essential points from the method of regeneration in more highly differentiated forms, such as *Planaria simplicissima*, described by Stevens ('01), and *Planaria maculata*, worked out by Curtis ('02) and Thacher ('02).

### *Technique.*

The material had been fixed in a mixture of corrosive sublimate and acetic acid, the regenerating pieces at the end of one, two, five, seven, ten, fourteen, and twenty-eight days. After being hardened in the alcohols, and embedded in paraffine, the whole worms were sectioned in transverse and sagittal planes, and the regenerated pieces in transverse, sagittal, and frontal planes. The sections were stained in Delafield's hæmatoxylin, followed by orange G. This combination gives a good differentiation of the various tissues. The reproductive cells stain purple, the mucus blue, the nuclei of the parenchyma cells brown, the parenchyma itself pale yellow, the muscle cells deeper yellow, and the cilia usually form a slightly stained border at the margin of the sections, in parts of which the separate cilia can be distinguished.

## Normal Structure.

Before describing the process of regeneration, it seems necessary to describe the normal structure, as this differs essentially from that of other Planarians, and has not been described in detail.

Fig. K is a sagittal section of a whole worm showing the general outline of the form and the location of the different openings; *x* is the digestive opening, *r* the female reproductive opening, and *p* the penis. It also shows the position of the cells that secrete the jelly in which the eggs are laid *j*.

Fig. 1 is a transverse section taken near the anterior end of the worm (Fig. K, *a—b*), showing the testis cells *t*, maturing spermatozoa *s*, mucus *m*, the parenchyma nuclei *n*, and the cilia *c*. Fig. 2 is a transverse section through the middle-region (Fig. K, *c—d*), showing in addition, egg cells *o*, the irregular digestive region *d*, containing some food *f*, and the digestive opening *x*. Fig. 3 is a transverse section near the posterior end (Fig. K, *e—f*), showing besides the foregoing features, the female reproductive opening *r*, and the jelly gland *j*. In these three sections, certain distinctions between the dorsal and ventral sides can be seen. Most of the mucus lies on the dorsal side. There are more nuclei on the ventral side than on the dorsal, and there is a marked aggregation of nuclei at the lateral edges of the ventral side. By comparing Fig. 4, a piece of the dorsal margin of a transverse section (similar to Fig. 2), with Fig. 5, a piece of the ventral margin, an additional difference appears, that of the arrangement of the muscle fibers. On the dorsal side, they are more regularly arranged, forming an outer circular and an inner longitudinal layer, while on the ventral side, there

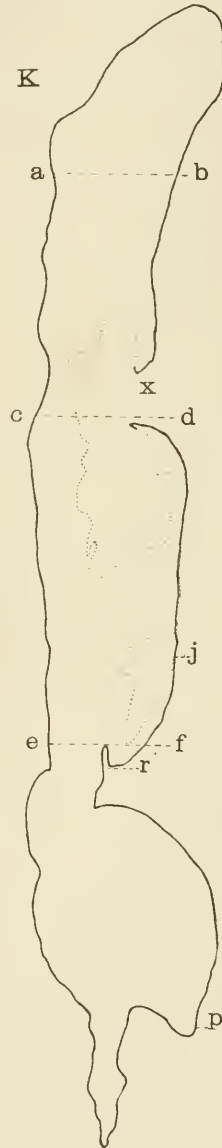

are no distinct layers. The apparent difference in the length of the cilia in these two figures (4 and 5) may be due to their being matted together in fixation.

There is no definite ectoderm or endoderm. The cells composing the mass of the body are the parenchyma cells, irregularly spindle-shaped, with large nuclei. (Fig. 4, *n*.) In many places, the outlines of these cells are so indefinite that it appears as though they merged into one another, forming a syncytium studded here and there with nuclei. Among these parenchyma cells are mucous cells, which have similar nuclei, but contain masses of a blue-staining secretion. (Fig. 4, *m*.) On the outer edge, where one would expect to find a definite ectoderm, these parenchyma cells are ciliated (Fig. 4, *c*), and stain a little more deeply, perhaps due to a cuticular secretion; but in no other way is the outer layer of cells different from the cells making up the mass of the body. This outer layer is not even arranged regularly, for the nuclei are at varying distances from the base of the cilia, and at irregular distances apart. The cells of the digestive region (Fig. 2, *d*)—it is not definite enough to be called a digestive tract—do not differ in any respect from the other parenchyma cells. In places pieces of crustaceans, which have been taken in as food, are found in between the cells near the digestive region (Fig. 2, *q*), showing that this cavity is continuous with the spaces between the loose parenchyma cells. At the opening of the digestive region (Fig. 2, *x*), a few of the cells are sometimes ciliated (Fig. 2, *c*) like the ectodermal parenchyma cells.

Muscle fibers are scattered throughout the parenchyma, but are accumulated especially among the ectodermal parenchyma cells (Fig. 4, *g*), around the female reproductive opening, and in the penis, of which they are the chief constituent. They vary much in size, in fact, so much that in sections stained with iron hæmatoxylin and orange G, some take the black and some the yellow color.

The reproductive cells are more distinctly differentiated than the other cells in these flatworms. They are not grouped into ovaries or testes, but they lie in definite positions among the parenchyma cells, and are discharged through definite openings, guarded by muscle cells having a sphincter-like arrangement. The testis cells (Fig. 2, *t*) extend along the lateral edge from near the anterior end to the penis which is an external muscular organ. (Fig.

K, *p*). The egg cells (Fig. 2, *o*) lie on each side of the median ventral line, extending from the region of the digestive opening back to the female reproductive pore. Just in front of this pore lie the cells which secrete the jelly in which the eggs are laid. (Fig. 3, *j*.)

This form has no central nervous system, no eyes or other sense organs, and no excretory system.

### *Regeneration.*

The regeneration of this form is as simple as its structure. The worms were cut into three pieces as stated in Part I, a head-piece, a middle-piece, and a tail-piece. In the regeneration of *Planaria simplicissima* and of *Planaria maculata*, the old ectoderm stretches over the cut surface in a thin layer, but the regenerative process in *Polychærus caudatus* is more like the regeneration after natural fission in *Planaria maculata*, as described by Curtis ('02), where the exposed surface simply heals over and embryonic cells migrate to that region and form the new tissue. In *Polychærus*, the cells at the cut end secrete a cuticular substance and develop cilia. Sections of most of the pieces fixed two days after being cut, show short cilia at the cut end (Fig. 6, *c*<sub>1</sub>) and the cells stain a little more deeply at the base of the cilia. In the five day sections, the cilia have reached their normal length. (Fig. 7, *c*.) By this time there is also a decided accumulation of nuclei at the regenerating end. Fig. 7 shows this, and a comparison of Fig. 7 with Fig. 6 clearly shows the progress of regeneration. This accumulation is not due to cell division, either in the regenerating end, or the old part. Cell division has been carefully looked for throughout the work, and the one or two cases which might possibly be interpreted as prophases of mitosis lose all significance from their rarity and the entire absence of actual mitoses; neither has any evidence of amitosis been discovered. Many of the nuclei in Fig. 7 have their long axes pointed toward the end, and the cells, as far as their outline can be made out, point in the same direction, indicating a streaming of parenchyma cells toward the regenerating region. In the whole worm, the parenchyma nuclei are accumulated on the ventral side and especially toward the lateral edge. In Fig. 9, a sagittal section some distance lateral to the median line, the accumulation of nuclei on the ventral side is continuous with the

accumulation at the regenerating end *n*, suggesting this accumulation as the chief source of the cells in the new part. Some of the cells come from the dorsal side, but the evidence from the examination of many sections is convincing that the majority come from the ventral side.

The muscle cells must develop from the parenchyma cells *in situ*, as they appear below the ectodermal parenchyma only in pieces which have been regenerating several days. (Fig. 8, *g*.) In Fig. 6, a section of a piece before the accumulation of nuclei had begun, some fibers appear scattered irregularly through the parenchyma near the end, but these are probably old fibers, as this section shows no definite layer of muscle fibers below the ectodermal parenchyma at the regenerating end.

The seven-day and ten-day sections show an increase in the length of the new part, but no other new points. In two weeks, most of the new tissue has taken on the loose parenchymatous character of the old part, as shown by the spaces in the tissue and the more scattered position of the nuclei in Fig. 10, only the extreme end of the regenerated tissue still having the nuclei in close proximity and the cells densely packed together. (The dotted lines in Figs. 9-12 show approximately the boundary between old and new parts.)

In the regeneration of one of the oldest head-pieces, a new digestive opening has formed. (Fig. 11, *x*.) It is in all respects like the opening in a full sized worm, being situated about halfway between the anterior and posterior ends, and opening directly from the digestive region to the exterior. Middle-pieces of this age have the old digestive opening, but some distance posterior to this, at the base of the new tissue, there is an accumulation of parenchyma and muscle cells, as in Fig. 12, *j*, which can be recognized as the anlage of the penis, for the sperm has moved down near to this anlage. Anterior to the penis is a slight indentation *r* which may indicate the anlage of the female genital pore.

Sections show that anterior regeneration is always slower than posterior; there is less new tissue at the anterior end than at the posterior, and it keeps its compact character and accumulation of nuclei longer than the posterior, as shown by comparing Fig. 7, an anterior end, with Fig. 8, a posterior end of the same age. In some pieces in which the anterior end folded under to form a pocket, as described in Part I, no regeneration can be seen in the

oldest stages, but in a few of these, the growth of new material between the united edges can be seen in section. (Fig. 13, v.) By studying the whole series of sections, this region can be identified as the place where the cut edges united. The accumulation of nuclei shows new tissue to be regenerating on both sides of the line of union.

A few cases of lateral regeneration were studied, but the sections showed no divergence from anterior and posterior regeneration.

The regeneration of *Polychærus caudatus* is an excellent example of the remolding of the old tissue in a piece of an organism, into the tissues and form of the whole organism, without the assistance of cell division by mitosis or amitosis. This is what Morgan calls morphallaxis. Other flatworms in which regeneration has been worked out histologically, *Planaria simplicissima* and *Planaria maculata*, show a proliferation of new cells at the cut end, as well as the changes of form due to morphallaxis, but in *Polychærus* the new part is formed wholly of cells which migrate from the old part. Regeneration in this form is, therefore, an example of morphallaxis, pure and simple.

Bryn Mawr College, Pa.  
April 19, 1905.

## LITERATURE.

- BARDEEN, C. R., '01.—On the Physiology of *Planaria maculata* with Especial Reference to the Phenomena of Regeneration. *Am. Journ. of Physiology*, vol. v, 1901.
- CHILD, C. M., '04a.—Studies on Regulation. IV. Some Experimental Modifications of Form Regulation in *Leptoplana*. *The Journal of Exp. Zoölogy*, vol. 1, No. 1, 1904.
- '04b.—Studies in Regulation. V. The Relation between the Central Nervous System and Regeneration in *Leptoplana*: Posterior Regeneration. *Ibid.*, No. 3, 1904.
- '04c.—Studies in Regulation. VI. The Relation between the Central Nervous System and Regulation in *Leptoplana*: Anterior and Lateral Regeneration. *Ibid.*, No. 4, 1904.
- CURTIS, W. C., '02.—Life History, Normal Fission, and Reproductive Organs of *Planaria maculata*. *Proc. Boston Soc. of Nat. Hist.*, vol. xxx, No. 7, 1902.

- LILLIE, F. R., '01.—Notes on Regeneration and Regulation in Planarians. *Am. Journal of Physiology*, vol. vi, 1901.
- MORGAN, T. H., '01.—Regeneration. *Columbia Univ. Biol. Series*, No. 7. New York, 1901.
- '04.—An Analysis of the Phenomena of Organic 'Polarity.' *Science*, N. S., vol. xx, No. 518.
- STEVENS, N. M., '01.—Notes on Regeneration *Planaria lugubris* (simplicissima). *Archiv. für Entw.*, Bd. xiii, H. 3, 1901.
- THACHER, H. F., '02.—Regeneration of a Pharynx in *Planaria maculata*. *Am. Naturalist*, vol. xxxvi, No. 428, 1902.

## EXPLANATION OF PLATES.

Figs. 1, 2, 3, 9, 10, 11, 12, 13 were drawn with Leitz oc. 2, obj. 3, camera lucida.

Figs. 4, 5, 6, 7, 8 were drawn with Leitz oc. 2, obj. 1-12, camera lucida.

Figs. 1 to 8 are reduced one-half.

The following lettering is used in all the figures: *c*, cilia; *c*<sub>1</sub>, cilia half developed; *d*, digestive region; *f*, food in digestive region; *g*, muscle fibers; *j*, jelly gland; *m*, mucus; *n*, nuclei of parenchyma cells; *o*, ova; *p*, penis; *q*, food among parenchyma cells; *r*, female reproductive opening; *s*, sperm; *t*, testis cells; *v*, new material; *x*, opening to digestive region; *y*, appendage.

## PLATE I.

- Fig. 1. Transverse section of whole worm near anterior end. (Fig. K, *a—b*.)
- Fig. 2. Transverse section of whole worm near middle, through the digestive opening. (Fig. K, *c—d*.)
- Fig. 3. Transverse section of whole worm toward posterior end, through female genital pore. (Fig. K, *e—f*.)
- Fig. 4. Portion of dorsal margin of transverse section.
- Fig. 5. Portion of ventral margin of transverse section.
- Fig. 6. Sagittal section of anterior end after 2 days' regeneration, showing developing cilia.
- Fig. 7. Sagittal section of anterior end after 5 days' regeneration, showing accumulation of nuclei.
- Fig. 8. Sagittal section of posterior end after 5 days' regeneration, showing appearance of muscle fibers.

## PLATE II.

- Fig. 9. Lateral sagittal section of middle-piece after 5 days' regeneration, showing accumulation of nuclei, *n*.
- Fig. 10. Median sagittal section of middle-piece after 2 weeks' regeneration, showing tissue with the loose character of the old. (Exceptionally rapid regeneration.)
- Fig. 11. Sagittal section of head-piece after 4 weeks' regeneration, showing the new digestive opening.
- Fig. 12. Sagittal section of middle-piece after 4 weeks' regeneration, showing anlage of penis and of female genital pore.
- Fig. 13. Transverse section of middle-piece (4 weeks) with a "pocket," showing triangle of new material, *v*.





A. M. Boring del.



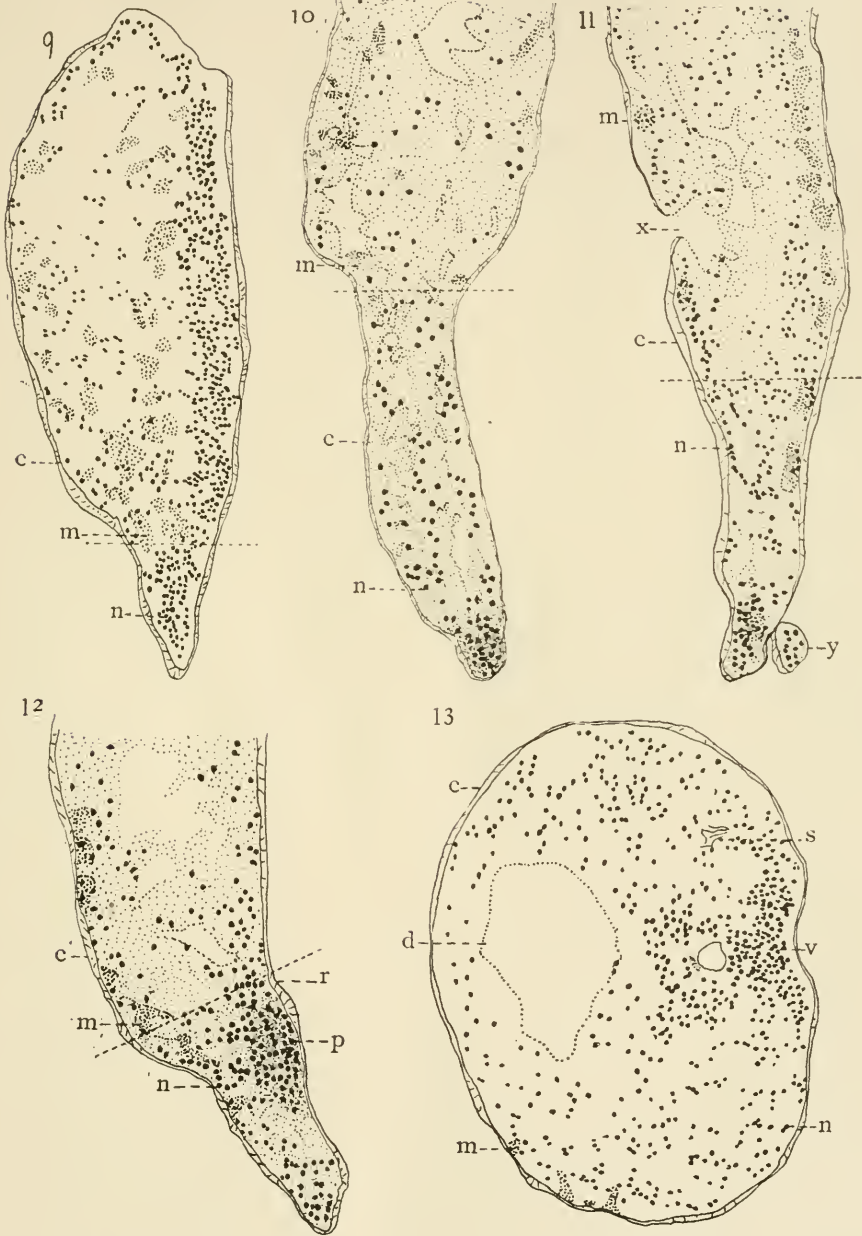

A. M. Boring del.



# THE RELATION OF THE DEGREE OF INJURY TO THE RATE OF REGENERATION.<sup>1</sup>

BY

CHARLES ZELENY.

## I. INTRODUCTION.

It is a common belief that an increase in the degree of injury to an animal lowers its vitality and thereby diminishes its capacity for repairing sustained injuries. It is certainly true that if an animal is mutilated to a degree so great that it can barely survive the operation a rapid rate of regeneration of the parts is not to be expected, though there is little direct evidence in favor of this statement. The general view that injury to an increased number of organs implies a decrease in the rate of regeneration of each, however apparent it may seem at first sight, needs further examination. The data to be given below prove very conclusively that the view is an erroneous one, for it is shown that the animal with the greater number of removed parts regenerates each part *more rapidly* than does the one with the lesser number of removed parts.

In the summer of 1902 the author performed some experiments on the fiddler crab, *Gelasimus*, which showed that when both chelæ are removed each of the regenerating buds grows more rapidly than does the single one in the cases where only one chela is removed. The rate of moulting of the animals is likewise greater in the individuals of the former group than in those of the latter. The difference was naturally more plainly made out in the female individuals which have chelæ of equal size than in the male individuals which have chelæ of unequal size. The results are, however, not as conclusive as they might have been, had the number of individuals been greater and had a greater length of time been available for the experiment.

---

<sup>1</sup>Contribution from the Zoölogical Laboratory of Indiana University, No. 68.

In the winter and spring of 1902-03 with the above results in mind two groups of experiments were undertaken to further test this point.

A comparison of the rate of regeneration of the arms in five series of the brittle-star, *Ophioglypha*, with one, two, three, four and five removed arms respectively, showed that excepting the case where all five arms are removed and in which the animals were dead or dying before the completion of the experiment, a series with a greater number of removed arms regenerates each arm faster than does a series with a smaller number of removed arms. Thus with an increase in the degree of injury there is *more* than a corresponding increase in the total amount of regeneration in a given time.

In the Crustacean, *Alpheus*, a result similar to that for *Gelasimus* was found but with the addition of a quantitative determination of the actual rate which was not possible for *Gelasimus* because of the slow rate of moulting in the latter. The *Alpheus* data are, however, complicated by the fact that the two chelæ are of unequal size and undergo a reversal upon removal of the larger one.<sup>1</sup> The number of individuals available for the final comparison was likewise small because a large proportion of the specimens cast their chelæ accidentally during the course of the experiment.<sup>2</sup>

It seemed desirable, therefore, to test the results in a more conclusive way upon a form which does not have the complications found in *Alpheus* and *Gelasimus*. The common crayfish, *Cambarus propinquus*, has chelæ which fulfill the requirements of such a form. They are equal in size and similar in character, are cast off at a definite breaking joint upon injury to their nerves and the animal does not readily throw off its appendages as a result of the necessary handling incidental to the course of the experiment. In one series the right chela alone was removed. In the other series the two chelæ and the last two pairs of walking legs were removed. The resultant data show very conclusively that *in the series with the greater degree of injury each chela regenerates more rapidly than the single removed chela of the series with the*

<sup>1</sup>Przibram, '01, Arch. Entw. Mech., xi; Wilson, '03, Biol. Bull., iv; Brues, '04, Biol. Bull., vi; Zeleny, '05, Journ. Exp. Zoöl., ii.

<sup>2</sup>The description of the preceding experiments is given in Journ. Exp. Zoöl., vol. ii, No. 1, Apr., 1905, pp. 1-102.

*lesser degree of injury. Likewise the members of the series with the greater injury moult more rapidly than those of the series with the lesser injury.*

## 2. METHOD.

The specimens used in the experiment were collected in a small brook about a mile and a half from the Indiana University campus at Bloomington. They were all taken from a part of the brook not exceeding two hundred feet in length and it is probable that the general conditions of the environment to which they had been subjected were similar for all up to the time of capture on October 11, 1904. About 150 specimens were obtained at this time and

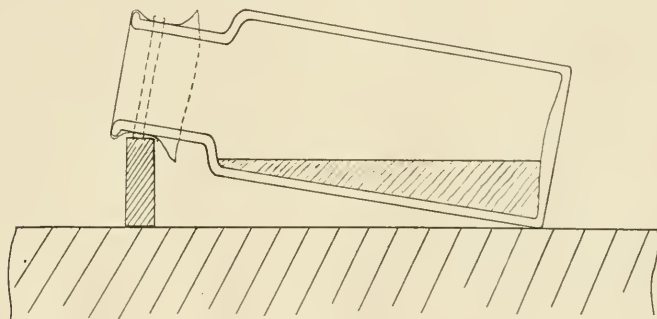

Fig. 1.

Diagram showing a bottle as arranged for the reception of one of the crayfish used in the experiment. See text description on page 350.

from this lot 77 of the individuals ranging in thoracic length from ten to twenty millimeters were selected and divided into two groups which were made as nearly as possible equivalent in point of size of individuals. In series A which comprised 36 individuals the right chela was removed at its breaking joint. In series B which comprised 41 individuals the two chelæ and the last two pairs of walking legs were removed in a similar manner. Except for this difference in the degree of injury the two series were consistently treated alike throughout the whole course of the experiment. The series with the greater injury (Series B) was purposely given the greater number of individuals in anticipation of a greater death rate in this series. Both males and females were included in each series.

The crayfish were kept in individual wide-mouthed bottles, which were inclined at a slight angle to the horizontal and were covered with pieces of cheese cloth held in place by rubber bands (see Fig. 1). The crayfish were fed every fifth day on frog meat or beef, the water being changed immediately after the meal. Under these conditions no difficulty was experienced in keeping the animals alive. The few deaths recorded during the course of the experiment were for the most part due to neglect in changing the water immediately after the meal. Such a suspension of ordinary care is especially liable to be fatal when occurring soon after a moult. The operation on the majority of the crayfish was performed October 12, 1904, and the experiment was closed April 20 after an interval of 181 days. A small minority comprising 16 individuals was operated on two days later and kept until April 22, the interval being likewise 181 days.

### 3. DATA.

The records of the experiment include the sex of the animals, the date of moulting, and the length in millimeters of the thorax and of the chelæ after each moult. The size of the regenerating walking legs of each individual in Series B is approximately expressed in my notes in fraction of the legs which are being replaced. The latter data are, however, not given in the tables reproduced in the present paper. In these tables (pp. 352 to 358) the moulting time is given in days after the operation. The thoracic length is the distance in millimeters between the posterior edge of the thorax and the base of the thoracic spine. The chela length is the greatest length in millimeters of the next to the last segment of the chela, the propodite.

The data are given in Tables I, II, III and IV. The males and females are separated because the rate of moulting and of regeneration was found to be different in the two sexes. The individuals in each table are arranged in order of thoracic length after the first moult. In the columns giving the original lengths, *i. e.*, the lengths before the operation, blank spaces indicate that the measurements were not taken. In the other columns a blank space indicates that the animal had not moulted when the experiment was closed, 181 days after the operation. In the last column the



number after "died" is the interval in days between the operation and the time of death.

A comparison of the rate of moulting in the two series is given in Table V. This table is derived from Tables I to IV and gives the number of male and female individuals which had moulted in each series 95 days, 130 days, and 181 days after the operation. The first column under each moult gives the number of individuals which have moulted, the second the number which have not moulted, the third the number which have died, and the fourth the *per cent of the living* which have moulted.

The data for the rate of regeneration as derived from Tables I to IV are given in Tables VI and VII. Table VI gives the male individuals of the two series and Table VII the female individuals. In these two tables the individuals are arranged in order of moulting, those moulting first being put at the head of the list. The specific amount of regeneration (Sp. Amt.) is the amount per unit of thoracic length at the end of the first moult. The specific rate of regeneration (Sp. Rate) is the amount of regeneration per unit of thoracic length per day.

#### EXPLANATION OF TABLES.

Series A = Series with right chela alone removed.

Series B = Series with the two chelæ and the last two pairs of walking legs removed.

In Tables I, II, III and IV the individuals are arranged in order of the thoracic length as determined after the first moult.

In Tables VI and VII they are arranged in order of the date of the first moult. In Series B the specific amount of regeneration and the specific rate are the averages of these quantities for the two chelæ of the individual.

TABLE I.—Series A. Males (181 days after operation).

Cat. No.	Original.		First Moul.				Second Moul.				Remarks.
	Thorax.	Left Chela.	Days.	Thorax.	Right Chela.	Left Chela.	Days.	Thorax.	Right Chela.	Left Chela.	
737	..	..	71	10.9	4.7	6.7	*	—	—	—	Died 157.
806	..	..	86	11.5	4.6	6.7	164	11.2	5.0	6.6	
746	..	..	3	—	—	—	?	12.4	5.3	7.3	Died 149.
797	..	..	57	12.2	5.7	7.6	144	12.6	5.8	7.3	
744	12.6	7.0	108	13.3	5.9	7.8	173	13.5	6.9	7.9	Died 73.
745	..	..	58	13.7	6.3	8.6	*	—	—	—	
736	..	..	72	14.2	6.0	9.7	143	14.8	7.6	10.0	Died 113.
776	14.1	11.7	..	..	..	..	..	..	..	..	
804	..	..	92	14.9	6.9	9.9	..	..	..	..	Died 113.
762	14.1	9.1	107	15.2	6.85	9.9	170	15.1	7.1	10.0	
778	..	..	105	15.5	6.7	8.9	..	..	..	..	Died 113.
777	14.9	9.3	137	15.9	7.3	10.3	..	..	..	..	
735	15.0	11.9	137	16.0	7.0	12.4	..	..	..	..	Died 113.
754	15.1	12.0	106	16.1	7.6	14.0	*	—	—	—	
761	16.1	11.0	116	16.6	7.0	11.8	..	..	..	..	Died 113.
752	16.2	12.1	112	17.7	8.0	13.0	..	..	..	..	
768	15.7	13.6	166	19.4	5.25	12.4	..	..	..	..	

TABLE II.—Series A. Females (181 days after operation).

Cat. No.	Original.		First Moul't.				Second Moul't.				Remarks.	
	Thorax.	Left Chela.	Days.	Thorax.	Right Chela.	Left Chela.	Days.	Thorax.	Right Chela.	Left Chela.		
791	10.3	6.4	135	11.0	4.6	6.4	..	..	..	..	{ *3d Moul't. 181-15.3-6.9- 9.2	
807	11.3	5.3	140	11.3	3.8	5.6	..	..	..	..		
775	13.1	8.5	119	14.0	6.0	9.1	..	..	..	..		
786	..	..	1	14.4	—	8.8	111	14.8	6.2	9.2		
785	..	8.0	104	14.6	6.3	8.3	180	14.0	6.4	7.9		
743	..	..	106	15.0	6.4	9.1	168	15.4	7.0	9.1		
784	13.9	9.1	163	15.2	6.0	9.6	..	..	..	..		
738	14.6	7.6	108	15.4	6.9	9.0	..	..	..	..		
760	14.6	9.6	165	15.7	6.0	9.4	..	..	..	..		
799	15.2	9.8	142	15.9	6.8	10.4	..	..	..	..		
796	15.1	10.2	133	16.2	6.7	10.6	..	..	..	..		
783	15.3	10.2	*	—	—	—	..	..	..	..		Died 154.
751	15.7	10.5	153	17.0	6.2	11.1	..	..	..	..		
798	16.0	10.2	..	..	..	..	..	..	..	..		
805	16.2	11.1	167	17.0	6.1	10.5	..	..	..	..		
753	17.1	12.0	..	..	..	..	..	..	..	..		
770	17.0	10.2	181	18.0	7.0	10.0	..	..	..	..		
767	17.8	11.2	..	..	..	..	..	..	..	..		
759	16.9	11.1	144	18.8	7.1	12.2	..	..	..	..		





TABLE V.—Rate of Moulting.

95 Days after Operation.

	First Moulting.				Second Moulting.			
	Moulted.	Not Moulting.	Dead.†	Per Cent* Moulting.	Moulted.	Not Moulting.	Dead.†	Per Cent* Moulting.
Series A ♂ . . . . .	7	10	0	41.0	0	16	1	0
Series B ♂ . . . . .	15	0	0	100.0	1	13	1	7.1
Series A ♀ . . . . .	1	18	0	5.3	0	19	0	0
Series B ♀ . . . . .	13	12	1	52.0	4	20	2	16.7

130 Days after Operation.

	First Moulting.**				Second Moulting.			
	Moulted.	Not Moulting.	Dead.†	Per Cent* Moulting.	Moulted.	Not Moulting.	Dead.†	Per Cent* Moulting.
Series A ♂ . . . . .	—	—	—	—	1	14	2	6.7
Series B ♂ . . . . .	—	—	—	—	7	6	2	53.8
Series A ♀ . . . . .	5	14	0	26.3	1	18	0	5.3
Series B ♀ †† . . . . .	19	6	1	76.0	12	12	2	50.0

181 Days after Operation.

	Second Moulting.				Third Moulting.			
	Moulted.	Not Moulting.	Dead.†	Per Cent* Moulting.	Moulted.	Not Moulting.	Dead.†	Per Cent* Moulting.
Series A ♂ . . . . .	6	8	3	42.9	0	14	3	0
Series B ♂ . . . . .	10	3	2	76.9	1	10	4	9.1
Series A ♀ . . . . .	3	15	1	16.7	1	17	1	5.6
Series B ♀ . . . . .	21	3	2	87.5	3	17	6	15.0

† Without having moulted.

\* Of living individuals.

\*\* A comparison of the males is not valid here because all those of Series B had already moulted 95 days after the operation.

†† One individual of Series B ♀ moulted a third time 128 days after the operation.

TABLE VI.—Rate of Regeneration (1). Males—First Moul.

Series A.					Series B.				
Cat. No.	Days.	Thorax.	Sp. Amt.	Sp. Rate.	Cat. No.	Days.	Thorax.	Sp. Amt.	Sp. Rate.
*746	3	..	..	..	†733	1	..	..	..
797	57	12.2	.467	.0082	739	33	12.2	.434	.0132
745	58	13.7	.460	.0079	789	34	11.0	.418	.0123
737	71	10.9	.431	.0061	803	42	13.5	.393	.0094
736	72	14.2	.423	.0059	††758	44	..	..	..
806	86	11.5	.400	.0047	780	44	14.8	.473	.0107
804	92	14.9	.463	.0050	792	44	13.4	.388	.0088
778	105	15.5	.432	.0041	790	48	15.5	.432	.0090
754	106	16.1	.472	.0045	801	65	14.3	.469	.0072
762	107	15.2	.451	.0042	732	69	16.5	.385	.0056
744	108	13.3	.444	.0041	765	73	17.5	.471	.0065
752	112	17.7	.452	.0040	740	76	14.7	.459	.0060
761	116	16.6	.422	.0036	748	83	15.8	.402	.0048
777	137	15.9	.459	.0034	764	84	14.7	.483	.0057
735	137	16.0	.437	.0032	773	95	16.9	.450	.0047
**768	166	19.4	..	..	..	..	..	..	..
776	181+	..	..	..	..	..	..	..	..
Av..	..	..	.444 ± .003	.0049 ± .0003	..	..	..	.435 ± .006	.0080 ± .0005

For explanation of Tables VI and VII, see pp. 350, 351.

\*, † No visible regeneration has taken place.

\*\* The stump of the operated leg was diseased for a long time after the operation and the data are therefore not included with the others.

+ The plus sign after 181 indicates that the animal had not moulted when the experiment was closed.

†† The animal moulted a second time before measurements for the first moult were taken.

TABLE VII.—Rate of Regeneration (2). Females—First Moul.

Series A.					Series B.				
Cat. No.	Days.	Thorax.	Sp. Amt.	Sp. Rate.	Cat. No.	Days.	Thorax.	Sp. Amt.	Sp. Rate.
†786	1	14.4	..	..	†788	1	..	..	..
785	104	14.6	.432	.0042	734	27	11.8	.415	.0154
743	106	15.0	.427	.0040	741	29	11.9	.395	.0136
738	108	15.4	.448	.0042	742	31	12.6	.433	.0140
775	119	14.0	.429	.0036	747	31	13.5	.456	.0147
796	133	16.2	.414	.0031	769	32	15.2	.408	.0127
791	135	11.0	.418	.0031	787	32	13.7	.412	.0129
807	140	11.3	.336	.0024	793	33	14.0	.382	.0116
799	142	15.9	.427	.0030	757	34	17.3	*	*
759	144	18.8	.378	.0026	795	35	13.5	.407	.0116
751	153	17.0	.365	.0024	794	37	12.4	.415	.0112
784	163	15.2	.395	.0024	800	37	13.9	.432	.0117
760	165	15.7	.382	.0023	763	52	16.9	.402	.0077
805	167	17.0	.359	.0021	781	104	17.5	*	*
770	181	18.0	.389	.0021	779	108	15.0	.373	.0035
783	154+	..	..	..	771	115	17.8	.399	.0035
798	181+	..	..	..	749	117	16.4	.375	.0032
753	181+	..	..	..	772	118	14.0	.443	.0038
767	181+	..	..	..	755	121	17.3	.399	.0033
..	..	..	..	..	731	134	16.1	.425	.0032
..	..	..	..	..	774	142	15.9	**	..
..	..	..	..	..	756	143	17.8	.390	.0027
..	..	..	..	..	750	147	19.0	.345	.0023
..	..	..	..	..	782	148	18.8	.383	.0026
..	..	..	..	..	766	161	19.8	*	*
..	..	..	..	..	802	17+	..	..	..
Av. 14 cases	..	..	.400 ± .006	.0030 ± .0001	Av. 20 cases	..	..	.403 ± .004	.0083 ± .0007

† No visible regeneration has taken place.

\* These cases are not included in the general result because one chela in each is much smaller than the other probably as a result of secondary injury.

\*\* Chelæ deformed and small. No measurement taken.

+ (Plus sign), see under Table VI.



## 4. RESULTS.

*Rate of Moulting.*

A comparison of Series A with Series B shows that the individuals of the latter, the ones with the greater degree of injury, *moult sooner* than those of the former, the ones with the lesser degree of injury. The data for the rate of moulting are collected in Table V in which is given the number of individuals of each series which

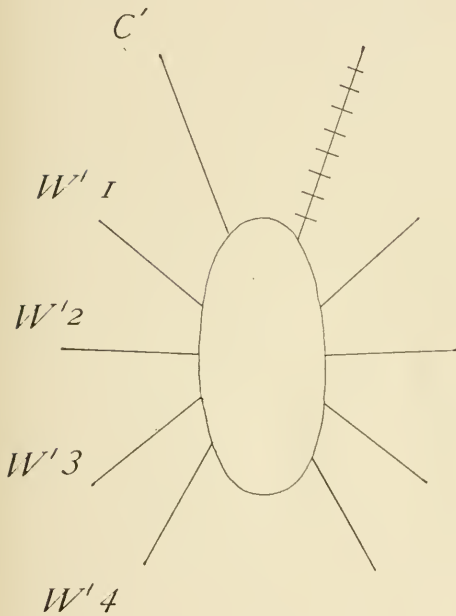

FIG. 2.

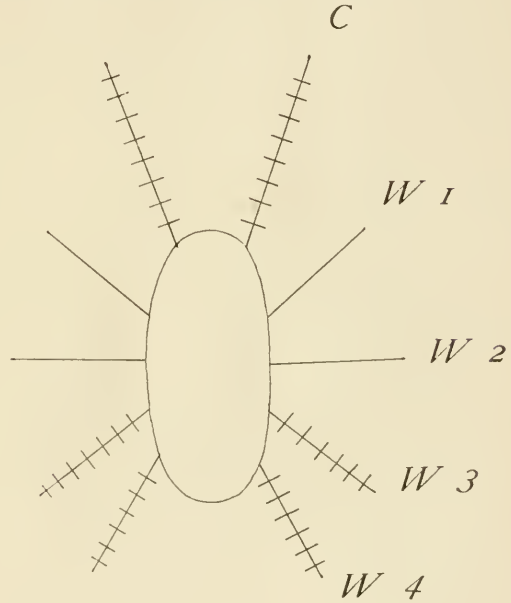

FIG. 3.

Diagrams to illustrate the comparative degree of injury in Series A (Fig. 2) and Series B (Fig. 3).

CC<sup>1</sup> = chelæ. W<sub>1</sub> to W<sub>4</sub>, W'<sub>1</sub> to W'<sub>4</sub> = walking legs. Plain lines = uninjured legs. Barred lines = removed legs.

had moulted once, twice or three times 95, 130, and 181 days after the operation. The males and females are considered separately in each case because the rate was found to differ in the two. The more rapid rate of moulting of the series with the greater degree of injury is evident throughout. Ninety-five days after the operation only seven out of the seventeen male members of the series with

the lesser injury (Series A), or 41 per cent, had moulted while at the same time all those of Series B had moulted. Likewise 95 days after the operation only one out of the nineteen female members of Series A or 5.3 per cent had moulted while thirteen out of the 25 living members of Series B, or 52.0 per cent, had done so. At the same time the only individuals that had moulted a second time belonged to the series with the greater injury. Of these one is a male and the other four are females.

One hundred and thirty days after the operation Series B shows a similar advantage over Series A. Only five out of the nineteen females, or 26.3 per cent, of Series A had moulted once or more as against nineteen out of twenty-five, or 76.0 per cent, of the living females of Series B. At the same time only 6.7 per cent of the males and 5.3 per cent of the females of Series A had moulted twice while 53.8 per cent of the males and 50.0 per cent of the females of Series B had done so. The one individual that had moulted a third time belongs to the series with the greater injury in accordance with the general rule for the other moults.

The final data as collected 181 days after the operation, when the experiment was closed, show the same advantage of Series B over Series A. Thus only 42.9 per cent of the living males and 16.7 per cent of the living females have moulted twice while 76.9 per cent of the living males and 87.5 per cent of the living females of Series B have done so. For the third moult at the same time there are none of the males and only one female, or 5.6 per cent of the living females, in Series A as against one male, or 9.1 per cent of the living males, and three females, or 15.0 per cent of those living, in series B.

The general result is very clear. The individuals of Series B moult more rapidly than those of Series A. Emphasis must be again laid on the fact that Series B differs from Series A only in the greater degree of injury in the former. All other conditions are as nearly alike as possible in the two cases.

#### *Specific Amount of Regeneration.*

The amount of regeneration of the right chela at the end of the first moult divided by the thoracic length gives a quotient which may be called the *specific amount* of regeneration or the amount per unit of thoracic length. It is a fairly *constant* quantity for the

individuals of one sex in a series and is *equal* in the two series. (See Tables VI and VII, pp. 357 and 358.) The amount of regeneration of the right chela at the end of the first moult is therefore the same no matter what the degree of injury may be. The average specific amount of regeneration for the males of Series A at the end of the first moult is .444 ( $\pm .003$ ). For the males of Series B at the same time it is .435 ( $\pm .006$ ). The difference between the two is just equal to the sum of the probable errors and therefore cannot be considered as significant. Likewise the females of Series A have an average specific amount of regeneration equal to .400 ( $\pm .006$ ) and those of Series B an average of .403 ( $\pm .004$ ). The difference is less than the sums of the probable errors and is therefore not significant.

These results show very definitely that the specific amount of regeneration of a removed chela at the end of the first moult after the operation is a constant which is not affected by the time of the moult, the size of the animal, or the degree of other injuries to the individual. Four of the individuals, which moulted very soon after the operation, three within the first day and one in three days, are not included in this statement. None of the individuals moulted in the interval between three and twenty-seven days after the operation so that it is not possible to say to what degree the statement holds true for this period. For all periods above 27 days up to 181 days when the experiment was closed the specific amount of regeneration is a fairly constant quantity for the first moult after the operation.

#### *Specific Rate of Regeneration.*

The specific amount of regeneration of the right chela divided by the number of days between the date of operation and the first moult gives the specific rate of regeneration. The specific rate of regeneration is the amount of regeneration per unit of thoracic length per day.

The average specific rate of regeneration of the two chelæ in the series with the greater injury (Series B) is *greater* than that of the one removed chela in Series A. This is brought out very definitely in Tables VI and VII (pp. 357 and 358). For the males the values of the specific rate are .0049 ( $\pm .0003$ ) for Series A and .0080 ( $\pm .0005$ ) for Series B. For the females the corresponding

values are .0030 ( $\pm .0001$ ) for Series A and .0083 ( $\pm .0007$ ) for Series B. In each instance there is a very striking advantage of the series with the greater injury over the one with the lesser injury. This amounts to 63 per cent for the males and 177 per cent for the females. The individuals with the two chelæ and the last two pairs of walking legs removed as compared with the individuals in which the right chela alone is removed regenerate the right chela more rapidly than do the latter. This takes place notwithstanding the fact that at the same time they have also to regenerate the left chela at the same rate as the right one and also the last two pairs of walking legs. The individual therefore which has the greater amount of material to regenerate regenerates each part faster than does the individual with the smaller amount of removed material.

*Relation between Rate of Moulting and Rate of Regeneration.*

The fact that the specific amount of regeneration is a constant for all individuals of a sex makes the relation between the rate of regeneration and the rate of moulting a very close one. One of three possibilities in the relation of the two must be the true one. The more rapid rate of regeneration of the limbs may be the cause of the acceleration of the moulting or the opposite may be the case or finally the two phenomena may be co-ordinate and only indirectly related. If the first is the case the growing limb-buds in pressing against their chitinous envelopes more vigorously in Series B must be supposed to act as the stimuli for the increase in the rate of moulting. If the second possibility is true the first result of the operation is an acceleration of the rate of moulting which secondarily affects the rate of regeneration. Finally it is possible that the stimulus of the removal of the limbs acts directly and independently upon both regeneration and moulting processes.

5. DISCUSSION.

In opposition to the very common belief that an increase in the degree of injury to an individual implies a lowering of its ability to repair the sustained injuries the experiments on the several forms mentioned above<sup>1</sup> have shown that with an increase in the

<sup>1</sup>Gelasimus, Alpheus, Ophioglypha, Cambarus (see pp. 347-362).

number of removed legs or arms there is *an increase and not a decrease* in the rate of regeneration of each. This striking fact must be reckoned with in any theory bearing on the nature of regeneration. It would be premature to attempt to build up a constructive theory on the basis of the few facts so far discovered. Enough, however, is clear to make profitable the mention of the bearing of the facts on some of the more common theories of regeneration.

1. Observers who have had to do with the responses of animals to adverse conditions have pointed out again and again the peculiar fact that the response to such adverse conditions is in a direction advantageous to the animal. The results of the present experiments may therefore be taken as another instance of such a response. The crayfish with the greater number of removed legs and the brittle-star with the greater number of removed arms respond to the greater injury by an increase in the rate of regeneration of each member. Obviously the animal with the greater number of removed appendages has more need of the absent organs than does the other. It therefore may seem very plain to some that the rate of regeneration is greater in the one case *because* there is more *need* of a rapid replacement in that case. It is but a step further to the familiar statement that the cause of any need in an organism may be taken as a sufficient cause for the fulfillment of that need. There are unfortunately a few who have been and will continue to be satisfied with superficial explanations of this character. For these the problem of regeneration is considered solved when the naive statement is made that if a part of an animal is removed it is obviously more advantageous to the animal to regenerate a new part than not to regenerate one.

2. The suggestion may be made that the animal with the greater number of appendages gone, exercises the regenerating ones more vigorously than does the animal with the smaller number gone. As a result of this greater activity the regenerating appendages grow more rapidly in the former case than in the latter. In support of this idea it may be said, for instance, that the animal which still has one uninjured chela concentrates its chela-functions upon that organ, thereby lessening the activity of the regenerating bud. On the other hand the animal with both chelæ gone having no uninjured chela upon which to concentrate its chela-functions exercises to their full extent the developing

functions of the new buds. Thus each of the new buds grows faster than the single bud of the other animal because each gets more exercise of its parts than does the latter. Unfortunately observations made upon the individuals of the two series did not show any difference between them as regards the activity of either the old or the new parts. It is, however, very hard to judge differences in activity in animals like the crayfish in the present experiment, for the specimens are observed only when disturbed by the presence of the observer. The individuals with one remaining chela under these circumstances naturally often put themselves in a defensive attitude threatening the observer with their uninjured chela. The members of the other series having no chela cannot do this. A strong individuality was found in the members of both series. Daily observation of the individuals in the experiment for 181 days with but a few gaps enabled me to make out striking differences in the activities of members of a single series. These individual differences in function were not correlated with any differences in the resulting regeneration as far as I was able to decide. Though there is no evidence one way or the other from the present instance, the comparative activities of the organs in future experiments of a similar character should be carefully observed. On the other hand there seems to be great danger in carrying the idea too far for it is inconceivable to me how the attempt of an animal to exercise a function for which it has no morphological background can lead to the formation of a structure furnishing the necessary background. Does not such a statement of the case come dangerously near to the other statement that "the cause for the existence of a need is a sufficient cause for the fulfillment of that need?" A mystical attempt to function resulting from the need to function has been supplied, that is all.

3. The difference in the mechanical redistribution of food materials which results from the difference in the extent of the injury may be supposed to cause directly the greater rate in the one series. A discussion of the assumptions which must be made in order to explain the facts on this basis will be interesting. Before going on it will be well to recognize the fact that the difference in activity of the parts in the two series as formulated above under the second suggestion (pp. 363, 364) is supposed to lead to a difference in the distribution of food materials which in turn brings about the difference in rate of growth. The same must be said of all

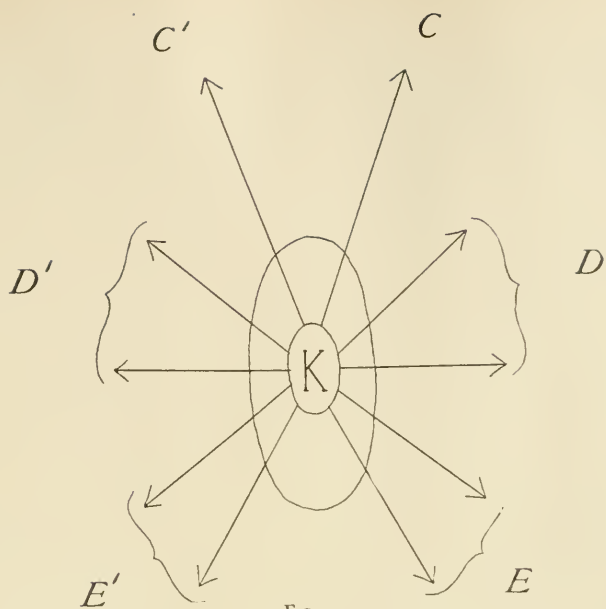

FIG. 4.

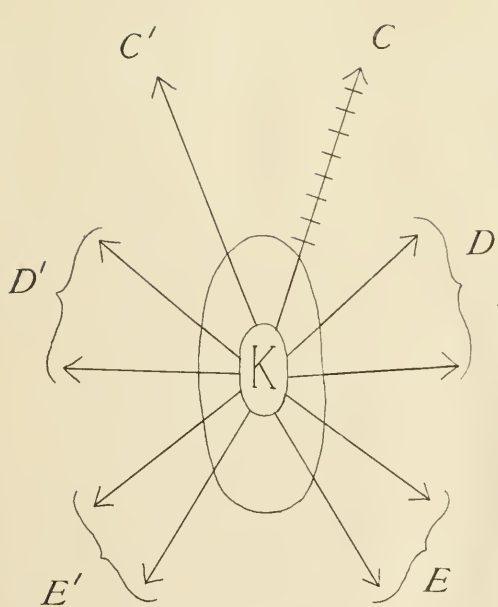

FIG. 5.

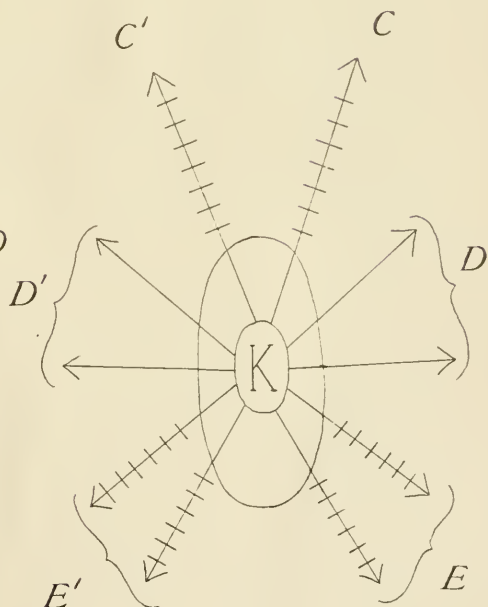

FIG. 6.

Diagrams to illustrate the distribution of food materials of a constant amount (K), to the limbs of an unoperated crayfish (Fig. 4), a crayfish of Series A (Fig. 5), and a crayfish of Series B (Fig. 6).

other attempts at explanation. The factor that they bring up may be supposed in every case to cause a difference in food-material distribution which in turn causes the difference in rate of growth. Under the present head it is therefore pertinent to discuss only the supposition that the direct mechanical disturbance of the channels of food-distribution shunts the materials off in such proportions into the new channels as to make probable an explanation purely on these grounds. At the very beginning the pure assumption must be made that the total amount of food materials elaborated and involved in chela-building in our case is a constant (K) in all individuals regardless of the character of the injury. The source and distribution of the food stuffs may be indicated by the diagrams shown in Figs. 4, 5 and 6. The facts to be explained are that chela C in Series A (Fig. 5) regenerates less rapidly than either chela C or C<sup>1</sup> in Series B (Fig. 6). The assumption according to the hypothesis now being tested is that the rate of growth and regeneration is determined by the amount of food material, an increase in the amount of food material going to a part determining the increase in rate of growth or regeneration of that part. The assumption is also made that the same kind of material is used in the growth of an uninjured chela as in the regeneration of a removed one and that the total amount of this food-material being distributed is a constant (K).

The distribution of the food-material may be represented for the three cases given in Figs. 4, 5 and 6 by the following formulae:

$$K = C + C^1 + D + D^1 + E + E^1. \quad (\text{Unoperated series, Fig. 4.})$$

$$= \text{reg. bud } C + C^1 + D + D^1 + E + E^1. \quad (\text{Series A, Fig. 5.})$$

$$= \text{reg. bud } C + \text{reg. bud } C^1 + D + D^1 + \text{reg. bud } E + \text{reg. bud } E^1. \quad (\text{Series B, Fig. 6.})$$

Now the rate of regeneration of chela C in Series B is greater than that of chela C in Series A. Therefore according to the present hypothesis the amount of food material going to the former chela bud is greater than that going to the latter or reg. bud C (in series B) > reg. bud C (in Series A).

Therefore

$$\text{reg. bud } C^1 + D + D^1 + \text{reg. bud } E + \text{reg. bud } E^1 > C^1 + D + D^1 + E + E^1.$$

(Series B.) (Series A.)

But  $D + D^1$  is the same in the two series.

Therefore

$$\text{reg. bud } C^1 + \text{reg. bud } E + \text{reg. bud } E^1 < C^1 + E + E^1$$



or the regenerating buds of the chelæ and walking legs receive less food material than do the same organs when uninjured. As the total amount of food material to be distributed is by hypothesis constant it follows that when a greater number of appendages is removed the surplus of material is greater. The surplus of material is therefore greater in Series B than in Series A and crowds upon both the regenerating parts more vigorously than in the latter. The regenerating buds in Series B, the series with the greater injury therefore grow more rapidly than those of Series A. Evidently when the degree of injury becomes great enough to disturb the mechanism of production of food material so that the amount of the latter is diminished and there is no longer a constant quantity  $K$ , the present statement cannot hold.

4. The results of the experiments on the relation between the degree of injury and the rate of regeneration of the crayfish and the brittle-star bring out very strongly an essential difference between crystals and organisms. In the former no matter what the number of removed parts the growth of each in a nutrient solution is entirely independent of the number or character of other removed parts in the same crystal. In the organism on the other hand there is no such independence. No part of the organism can be removed without affecting all other parts. This difference may, however, be due to the difference in the nature of the food-supply and not to an essential difference in the structures themselves. In crystals the food material is external and practically inexhaustible. Each part is thus independent of restrictions due to amount of food material.

5. The stimulation of the nerve of a leg or arm as a result of the injury to that member may be supposed to induce the processes leading to its regeneration. If it is assumed that an increase in stimulation causes more than a corresponding increase in intensity of such processes there will result a greater rate of regeneration in an animal with a greater injury than in one with a lesser injury. Physiologists have found that in general the curves for increasing stimulus and increasing response are not parallel. In some cases and this is especially true near the lower limits of the curves, the response curve runs up faster than does the stimulation curve. The organism possesses some inertia in every case and it is necessary to overcome this before any response at all is obtained. Having passed the lower limit, however, there is a very rapid upward

rise of the response curve in many instances. May not the acceleration of the regeneration rate with an increase in injury to the animal be explained on a similar basis?

6. In a series of experiments on the opercula of the Serpulid worms it was shown that when the large functional operculum is cut off near the middle of its stalk the small rudimentary operculum of the opposite side develops into a functional operculum while the remaining stalk of the old functional drops off at its base and in place of it a new rudimentary operculum is developed. The final result of the operation is therefore a reversal in position of the opercula. When the rudimentary operculum is cut off a new rudimentary is regenerated in its place. When the whole head region of the animal is cut off the two opercula which are regenerated are equal in size and resemble the old functional one.<sup>1</sup> It seems therefore that when one of the regenerating buds gets a start over the other it holds the latter back at the rudimentary stage. On the other hand when both buds have an equal start two opercula of equal size are developed. A retardation stimulus must be assumed to be given out by the functional operculum which holds the rudimentary operculum in check. When the organ is removed the retardation stimulus is likewise removed and the rudimentary operculum is enabled to develop into a functional one.

The same method of reasoning may be applied to the case of the regenerating chelæ of the crayfish. Each uninjured chela may be assumed to exert a retarding influence upon the growth or regeneration of all the others. When only one chela is removed the number of uninjured limbs remaining is greater than when the other chela and the last two pairs of walking legs are also removed. The retardation influence in the former case is therefore greater than it is in the latter and correspondingly the rate of regeneration in the former case is smaller than it is in the latter.

The term "retardation influence or stimulus" is undoubtedly a very vague one. It may perhaps be best considered as a nervous

---

<sup>1</sup>The results obtained for the chelæ of *Alpheus* are essentially similar except in the case with both chelæ removed where the regenerating chelæ are not alike. The difference here is probably due to the fact that the removal of both chelæ at their breaking joints leaves a basal stump on each side and is not a total removal as in the corresponding case of the Serpulid opercula. However, the resulting chelæ even here show an approach toward similarity. (See Przibram, '01, *Arch. Entw. Mech.*, xii; Wilson, '03, *Biol. Bull.*, iv; Zeleny, '05, *Journ. Exp. Zool.*, ii.)

influence exerted either upon the other organ or organs directly or else upon the mechanism for carrying food materials to those organs. The retardation influence is brought out in a somewhat different light when considered as a manifestation of the inertia of the organism. This idea also tends to unite the two suggestions of *positive stimulation* as a result of injury to the animal and the *negative or retardation stimulus* exerted by the uninjured organs. The former acts after the operation in overcoming the inertia of the organism. The latter on the other hand is merely a manifestation of the same inertia acting before removal.

The crayfish data when taken alone furnish no evidence in favor of either one of these two views as opposed to the other. The experiments on the Serpulid opercula and *Alpheus* chelæ, however, cannot be as well explained by the positive stimulation theory as by the retardation view.

The foregoing speculations are evidently of but small direct value. Their purpose is accomplished if they have emphasized the importance of the discovered relation between the degree of injury and the rate of regeneration in any general theory of regeneration.

#### 6. SUMMARY.

A comparison was made of the rate of regeneration and the rate of moulting in two series of crayfish with different degrees of injury. In one series the right chela alone was removed. In the other series the two chelæ and the last two pairs of walking legs were removed. It was found that the rate of regeneration of each chela in the series with the *greater* injury is greater than that of the single removed chela in the series with the lesser injury. Likewise the rate of moulting of the animals is greater in the former series than in the latter.

Indiana University,  
May 31, 1905.



## STUDIES ON CHROMOSOMES.

### I. THE BEHAVIOR OF THE IDIOCHROMOSOMES IN HEMIPTERA.<sup>1</sup>

BY

EDMUND B. WILSON.

WITH 7 FIGURES.

In studying the spermatocyte-divisions in *Lygæus turcicus* and *Cœnus delius*, and afterward in several other genera of Hemiptera, my attention was directed to the fact that the number of chromosomes appeared to vary, polar views of the equatorial plate showing sometimes seven chromosomes, sometimes eight (*cf.* Figs. 1*b*, 1*i*, 2*a*, 2*i*, 3*d*, 3*f*, etc.). Montgomery, in his extensive comparative paper of 1901, describes and figures a similar variation in a number of cases, including *Cœnus delius* and *Euschistus tristigmus* ('01, 1, pp. 161, 166), and in the latter case considered it as a result of variations in the synapsis of the two "chromatin nucleoli" which he supposed might either conjugate to form a bivalent body before the first division (in which case this division

<sup>1</sup>This paper is based on a study of some very fine series of sections of the testes of certain Hemiptera, prepared six or eight years ago by Dr. F. C. Paulmier, in connection with his valuable paper on the spermatogenesis of *Anasa tristis* ('99). Part of the original *Anasa* sections, with a number of series of the testes of some other insects, were given to the cytological cabinet of the Columbia laboratory at that time; some of the best of the remainder were subsequently loaned to Mr. Sutton, and others to Dr. Dublin, for comparison with their work on the spermatogenesis of other forms. Certain inconsistencies in the literature relating to the accessory chromosome and the microchromosomes or "chromatin-nucleoli" led me to re-examine the preparations of *Anasa* and some of the other genera, which yielded some new and interesting conclusions in the case of *Anasa*, and also of *Alydus*, *Lygæus* and *Cœnus*. Dr. Paulmier being preoccupied with other lines of work did not find it practicable again to take up his cytological studies, and he was generous enough to give me, for the laboratory, his entire set of preparations, comprising, in addition to the slides already given or loaned, serial sections of more than a hundred testes representing upward of twenty genera of Hemiptera and other insects. A typical series of the Hemiptera from which these testes were taken had been identified by the eminent specialist, Mr. P. R. Uhler. Much of this material is admirably fixed, sectioned and stained, and the best preparations are a model of technical excellence, showing especially the chromosomes of the spermatogonial and spermatocyte divisions with a clearness and brilliancy comparable with that of the best *Ascaris* preparations. The

was described as showing but seven chromosomes) or might remain separate during this division (in which case eight separate chromosomes appear). I soon found, however, that in *Lygæus* and *Cœnus* whole cysts differed in this respect, all of the cells of a given cyst constantly showing one number or the other. With this is correlated the fact that in the anaphases of the second division *no accessory chromosome in the usual sense of the term is present*, all the spermatid-nuclei receiving the same number of chromosomes, namely, seven, which is half the spermatogonial number in both species. Further study conclusively showed that in both of the species the cells with eight chromosomes were primary spermatocytes undergoing the first maturation-division, while those with seven were the secondary spermatocytes undergoing the second division. Of this fact no doubt can exist, since the secondary spermatocytes are much smaller than the primary ones, the spindles are shorter, the chromosomes only half as large, the metaphase-figures are often found in the same cysts with the characteristic late anaphases and telophases, and all the stages of both divisions were found in abundance. Though a great number of division-figures have been examined, I have never seen seven chromosomes in the first division in any of the forms examined; and though I will not deny that Montgomery may be correct in the statement that such forms occur, I believe he was misled on

---

most successful preparations are from material fixed with strong Flemming's fluid, and stained with iron hæmatoxylin followed by long extraction, in some cases followed also by counter staining with Congo red or orange G. These show the cytoplasm completely decolorized, the chromosomes intensely black, and with outlines of such regularity and sharpness that the most careful camera drawings give the appearance of being schematized. A few very fine series were stained with Zwaardemaker's saffranin (which gives a splendid transparent stain). Many others were fastened to the slide unstained, and some of these I have stained with saffranin and gentian violet (the method recommended by Montgomery) which have given very valuable control results, especially in regard to the accessory chromosome and plasmosome which in the earlier growth stages are not well differentiated by the hæmatoxylin. I am much indebted to Dr. Paulmier's generosity in placing at my disposal this valuable material, to which I have since added many new preparations of my own.

In a subsequent paper I shall describe the results of a re-examination of some of the maturation phenomena in *Anasa* and *Alydus*, in both of which there is demonstrative evidence that the accessory chromosome is not the small central chromosome or microchromosome ("chromatin-nucleolus" of Montgomery), as Paulmier supposed in the case of *Anasa*, but the odd or peripheral one, precisely as Gross ('04) has recently described in *Syromastes*. While looking over some of the other species for the sake of comparison my attention was directed, first in the spermatogenesis of *Lygæus turcicus* and *Cœnus delius* and afterward in that of *Euschistus*, *Podisus* and other forms, to the phenomena which form the subject of the present paper.

this point by failing in some cases to distinguish between the two divisions.

On tracing out the history of the two divisions step by step, decisive proof was obtained that the apparent reduction in number is brought about in the period immediately following the final anaphase of the first division (which coincides with the earliest prophase of the second division) by a conjugation of two unequal chromosomes that occupy the center of the equatorial plate in the first division and evidently correspond to some of the forms designated by Montgomery as "chromatin-nucleoli." This process can be determined with certainty, owing to the fact that in all of the species, with a single exception, one of the two conjugating chromosomes is much smaller than the others, while in *Lygæus* both are much smaller, and they are very unequal in size. The central dyad of the second division is therefore asymmetrical, one of its constituents being in *Lygæus* not less than five or six, and in *Cœnus* not less than two or three, times the bulk of the other. The two unequal constituents of this dyad are then immediately separated again in the ensuing division in such a manner that *in both species one half the spermatids receive the smaller, one half the larger, moiety of the central chromosome (or dyad) of the second division.* An essentially similar process was ultimately found to occur in *Euschistus fissilis*, in another undetermined species of the same genus, in *Brochymena*, *Nezara*, *Podisus* and *Trichopepla*. The first four of these show the same chromosome-numbers as in *Lygæus* and *Cœnus*. In *Podisus* the number is in each division one more than in the corresponding divisions of the other genera (*i. e.*, respectively 9 and 8 instead of 8 and 7, while the spermatogonial number is 16 instead of 14).<sup>1</sup> *Nezara* differs from the other genera in the fact, which is of importance for a comparison with such forms as *Anasa* or *Alydus*, that the two chromosomes which undergo conjugation after the first division *are of equal size*; so that in this form the two classes of spermatids are indistinguishable by the eye. Since the eight species I have

---

<sup>1</sup>In several of these cases the numbers do not agree with those given by Montgomery ('01, 1). I believe this observer to have been misled by the fact, which he also observed in some cases, that the first division shows one more than half the spermatogonial number of chromosomes; and it is easy to mistake the latter number owing to the fact that the larger spermatogonial chromosomes often show a more or less marked constriction in the middle. Slightly oblique views of the late metaphase, when the chromosomes are double, may also readily give an erroneous result.

examined represent two different families of Hemiptera (Pentatomidæ and Lygæidæ) the idiochromosomes will probably be found to be of wide occurrence in the group.<sup>1</sup> The only other case known to me in any higher plant or animal of the unequal division of a chromosome (or chromatin-body) in karyokinesis occurs in *Tingis clavata*, regarding which Montgomery states that one of the chromosomes of the first division "very frequently is seen to be characterized in having its two components of very unequal volume" ('01, 2, p. 262). This author also observed a considerable number of cases in which the "chromatin nucleoli" are unequal in the rest stage of the spermatogonia, and he describes some forms in which a similar condition appears in the growth-period of the spermatocytes (*e. g.*, in *Trichopepla*, *Peribalus* and *Euschistus tristigmus*). In the last-named species he found that a separation of the two unequal "chromatin nucleoli" takes place in the second mitosis ('01, 1, pp. 161, 162), but expressly states that they are not joined together in the equatorial plate (*op. cit.*, p. 162). It is evident from Montgomery's brief description that this phenomenon is similar to, and probably identical with, the one that forms the subject of this paper.

#### TERMINOLOGY.

Since confusion may readily arise in the terminology, I wish to define clearly the terms that will be employed throughout this paper and its successors. I shall apply the term "chromosome" to each coherent chromatin-mass, whatever be its form, mode of origin or valence, which as such enters the equatorial plate. In the case of compound or plurivalent chromosomes ("tetrads" or "dyads") McClung's term "chromatid" may conveniently be applied to each of their univalent constituents. I may call attention, in connection with this, to the fact that the valence of chromosomes cannot be determined by mere inspection of their form. In many Hemiptera, for example, the chromosomes of the first maturation-division frequently show a dyad-like or dumb-bell shape (typically the case, for example, in *Euschistus*, *Lygæus* or *Cœnus*) even though in earlier stages they are plainly quadripar-

<sup>1</sup>Since writing the above I have found the idiochromosomes in several additional genera. In *Mineus* they are only slightly unequal, in *Murgantia* nearly as unequal as in *Lygæus*. *Nezara*, *Mineus*, *Brochymena*, *Euschistus*, *Murgantia* and *Lygæus* thus show a progressively graded series of stages in the size-differentiation of this peculiar pair of chromosomes.



tite; and such dyad-like forms, agreeing both in mode of origin and in fate with actual tetrads, may occur in the same equatorial plate with obviously quadripartite forms (*cf.* Fig. 2*e*). Conversely it will be shown beyond that bivalent and univalent chromosomes occurring in the same equatorial plate may exactly agree in form, though having a wholly different mode of origin.

The purely descriptive term "idiochromosomes" (peculiar or distinctive chromosomes) will be applied to the two chromosomes, usually unequal in size, which, as stated above, undergo a very late conjugation and subsequent asymmetrical distribution to the spermatid-nuclei. These bodies, as already stated, are identical with some of those to which Montgomery ('01, '04) has applied the term "chromatin nucleoli." This use of the latter term is, however, undesirable, since the accessory chromosome also appears in the growth-period (of Orthoptera and some Hemiptera) in the form of a chromatin-nucleolus. I shall, therefore, employ the latter term in a broader sense to designate any compact deeply staining chromatin-mass, present in the resting nucleus, which afterward contributes to the formation of the chromosomes. When, as in case of the accessory chromosome, or the idiochromosomes, such a chromatin-nucleolus represents a single chromosome or pair of chromosomes it may conveniently be called a "chromosome-nucleolus"; but I think this term should be restricted to the resting nuclei and cannot appropriately be applied to the corresponding chromosome of the division-stage. Especially large or small chromosomes may be designated as "macrochromosomes" or "microchromosomes," irrespective of their behavior.

#### DESCRIPTIVE.

In the following account *Lygæus* and *Cœnus* will be taken as types, a brief comparison of the other forms being added. Some of the latter—especially *Brochymena* and *Nezara*—present features of peculiar interest which I hope to make the subject of a special study hereafter.

#### 1. *The Maturation Divisions.*

*Lygæus* and *Cœnus* show an extremely close agreement in the general history of the chromosome-group, and especially in the behavior of the idiochromosomes; though the earlier history of

these bodies shows a more primitive condition in the former genus. I have followed their behavior in the early stages less completely in *Euschistus* and *Podisus*, but their behavior during the maturation-divisions in these forms is closely similar to that of the others and leads to an exactly similar result. *Lygæus* is in some respects the most favorable of all these species owing to the remarkable disparity in size between the idiochromosomes; and to the fact that both are so much smaller than the other chromosomes as to admit of their immediate identification at every period.

In all the species, the chromosomes show distinct and constant size-differences. A largest chromosome or macrochromosome may be distinguished in all, and in most cases a second largest; and in all, the small idiochromosome is the smallest of the group and typically lies near the center of the equatorial plate. (Figs. 1*b*, 2*c*, 2*d*, 3*a*, *d*, *f*, etc.) It is difficult to be sure of the size-differences in case of the other chromosomes, owing to variations in form and position, which produce various degrees of foreshortening. In all the forms, with the exception of *Nezara*, the larger chromosomes of the first division are typically arranged in an irregular ring within which lie the two idiochromosomes, side by side, but always quite separate (Figs. 1*b*, 2*a*, 3*a*, *d*, *j*, etc.). This grouping is apparently invariable in *Lygæus*, but in *Cœnus* and *Euschistus* the larger idiochromosome frequently lies in the outer ring (Figs. 2*b*, 3*e*). In *Lygæus* the two idiochromosomes, within the ring, are always much smaller than any of the outer ones, and the smaller is so minute that at first sight I mistook it for a centrosome.<sup>1</sup> In *Cœnus* both the idiochromosomes are relatively larger than in *Lygæus*, and their inequality of size is less striking (Fig. 2, *a*, *b*, *g*, *b*). The larger one is about equal in size to the smallest of the peripheral chromosomes and hence cannot be certainly distinguished when it lies in the outer ring (Fig. 2*b*). In both species an equatorial plate occasionally occurs in which nine chromosomes clearly appear (Figs. 1*d*, 2*c*), but this is exceptional, and I have never found a spindle showing this body in division. The presence of this additional chromosome is probably due to a failure of synapsis between two of the spermatogonial chromosomes which normally conjugate to form a bivalent body, and it is evidently to be regarded as an abnormal condition.

<sup>1</sup>Cf. Montgomery's Fig. 105, of *Corizus*, '01, 1.



FIG. 1.<sup>1</sup>

*Lygæus turcicus*. *a, e*, metaphase of first division—in the first two figures several of the chromosomes are represented out of their natural positions at one side; *b, c*, normal metaphase-groups in polar view, first division; *d*, abnormal form with nine chromosomes; *f*, the idiochromosomes and two others, in early anaphase, first division; *g, h*, daughter-groups, late anaphase first division, from the same spindle; *i, j*, equatorial plates of second division, at the metaphase, in polar view; *k*, prophase of second division, showing all the chromosomes just before taking up their definitive positions; *l*, metaphase of second division—three of the chromosomes drawn out of position at one side; *m*, separation of the idiochromosomes, second division; *n, o*, daughter-groups, late anaphase of second division, from the same spindle.

<sup>1</sup>All of the figures were drawn as carefully as possible with the camera, a  $\frac{1}{12}$  oil immersion, and compensation ocular 12 (Zeiss), enlarged  $2\frac{1}{2}$  diameters with a drawing camera, carefully corrected by renewed comparison with the objects and then reduced in the engraving to one-half. At such an enlargement some error is unavoidable, but great care has been taken to represent the chromosomes

In side views of the spindles both species usually show the chromosomes of a symmetrical dumb-bell shape (Figs. 1*a*, *e*, 2*d*), though one or more of them may appear quadripartite, as is especially common in case of the largest one or macrochromosome (Fig. 2*b*, *e*). In both forms all of the eight chromosomes are symmetrically divided in the first mitosis (Figs. 1*f*, 2*e*, *f*), giving rise to two exactly similar daughter-groups of eight chromosomes each (Figs. 1*g*, *b*, 2*g*, *b*). The rate at which the daughter-chromosomes separate varies widely in different cases. Frequently the idiochromosomes lead the way in the march toward the poles and may be widely separated at a time when one or more of the larger chromosomes are only just separating (Fig. 1*f*), while the macrochromosome often lags behind the others (Fig. 2*e*); but now and then a spindle shows the reverse condition, the small idiochromosome being the slowest of the group. In the end the daughter-chromosomes come to lie at the same level, and in the final anaphase are drawn more closely together. At this period the grouping of the chromosomes is exactly the same in the two species, the two idiochromosomes lying close together and closely surrounded by a ring formed by the six larger chromosomes. In spindles that lie vertically or slightly obliquely the two daughter-groups may in both species be seen, with the greatest clearness, to be exact duplicates of each other, proving beyond doubt the equal division of all of the eight chromosomes of the first mitosis (Figs. 1*g*, *b*, 2*g*, *b*), and the size-relations of the chromosomes persist without noticeable change. In *Lygæus* at this period the two idiochromosomes are still as a rule clearly separated; in *Cænus* this may be the case, but they sometimes lie in close contact, already forming a dyad almost identical in appearance with the central unequal dyad of the second mitosis (Fig. 2*b*).

as accurately as possible, and none of the figures are schematized in this respect, except that in a few cases one or more of the chromosomes have been drawn out of their natural positions in order to avoid confusion in the figures. It should be noted that in the division-stages there is some variation in the actual size of the chromosomes, and this is more or less exaggerated in the figures owing partly to slight differences in position, which cause foreshortening in various degrees, and partly to differences in form (different degrees of elongation of the chromosomes cause corresponding variations in thickness as seen in polar view). No attempt has been made to represent the minuter details of the spindle-fibers or asters, though the figures are but slightly schematized in this respect. Some of the stages of the growth-period (especially stages *b*, *d* and *f*) are difficult to represent adequately in pen drawings; though I have attempted to show them as accurately as possible.

In all the figures the idiochromosomes are marked *i*, the plasmosome *p*.

In the stage that immediately follows, the chromosomes for a brief period become so crowded that their exact changes cannot be followed. In slightly later prophases of the second division, which follows without a pause, the chromosomes again spread apart.

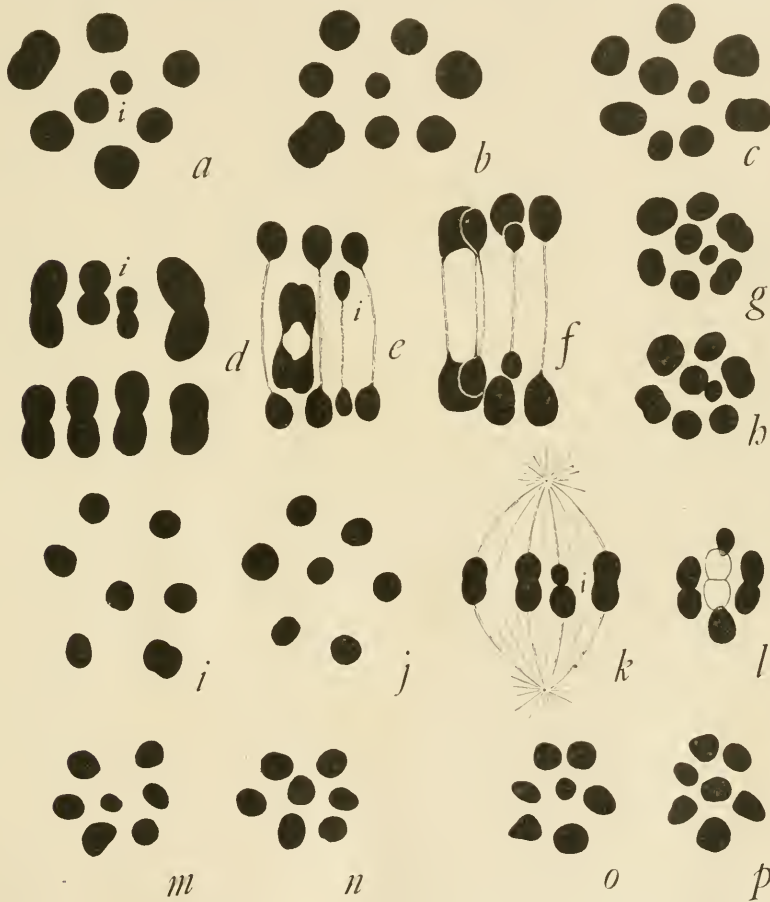

FIG. 2.

*Coenus delius*. *a, b*, normal equatorial plates, metaphase of first division; *c*, abnormal form with nine chromosomes; *d*, the entire chromosome-group, first division metaphase, in side view, the upper four in their natural position; *e, f*, anaphases in side view showing in each case the idiochromosomes and three others; *g, h*, daughter-groups, late anaphase of first division, from the same spindle; *i, j*, equatorial plates, metaphase of second division, polar view; *k*, metaphase of second division; *l*, later metaphase, separation of the idiochromosomes; *m, n—o, p*, two pairs of daughter-groups, late anaphase, second division, in each case from the same spindle.

and it may now be seen, even before the equatorial plate is formed, that the two idiochromosomes, retaining their characteristic size-relations, have conjugated to form an asymmetrical dyad, which shows the most striking contrast to the six other dyads, all of which have a symmetrical dumb-bell shape (Fig. 1*k*). The seven dyads are now drawn into the equatorial plate, the asymmetrical one invariably lying at the center of a ring formed by the six symmetrical ones (Figs. 1*l*, *m*, 2*k*, 3*b*). These dyads place themselves with their long axes parallel to that of the spindle, so that when seen in polar view they present a circular or more or less ovoidal outline; if they lie in a slightly oblique position, as is frequently the case, they may give a bipartite appearance. Since in polar view the small idiochromosome lies above or below the large one it is usually invisible, and hence only the larger one appears at the center of the equatorial plate (Figs. 1*i*, *j*, 2*i*, *j*). In the early metaphase the chromosomes, especially in *Cœnus*, are often rather widely separated, so that the equatorial plate may be nearly or quite as wide as in the first division (*cf.* Figs. 2*a*, *b*, 2*i*, *j*). Such figures might at first sight readily be mistaken for those of the first division, but without exception, in my material, both the chromosomes and the cell-bodies of the 7-chromosome cells are much smaller than those of the 8-chromosome ones; and the completeness of the series and the great number of division-figures that I have had under observation precludes, I think, the possibility of error on this point.

In the ensuing division each of the dyads draws apart into two spheroidal single chromosomes, the peripheral ones dividing equally, while the idiochromosome-dyad separates into its two unequal constituents—invariably, I believe, leading the way in the division (Figs. 1*m*, 2*l*, 3*c*, *g*, *k*). Owing to this fact the unequal division of the central dyad may be seen with unmistakable clearness. In polar or slightly oblique view of the late anaphases, when both daughter-groups are visible, the asymmetrical result may plainly be seen. In such figures the two daughter-groups show a most striking contrast to those of the first division, being no longer duplicates of each other, and both showing seven instead of eight chromosomes. Each daughter-group shows, as in the metaphase-group, a ring of six larger chromosomes (now single spheroidal bodies) within which lies at one pole the smaller, at the other pole the larger, of the idiochromosomes (Figs. 1*n*, *o*, 2*m*,

*n, o, p*). Each spermatid-nucleus thus receives seven chromosomes, one-half the spermatogonial number, and no accessory chromosome, in the usual sense of the word, is present; but *the spermatids nevertheless consist of two groups, equal in number, one of which contains the smaller, the other the larger of the idiochromosomes*. In the mature spermatozoa I have not been able to detect any corresponding difference.

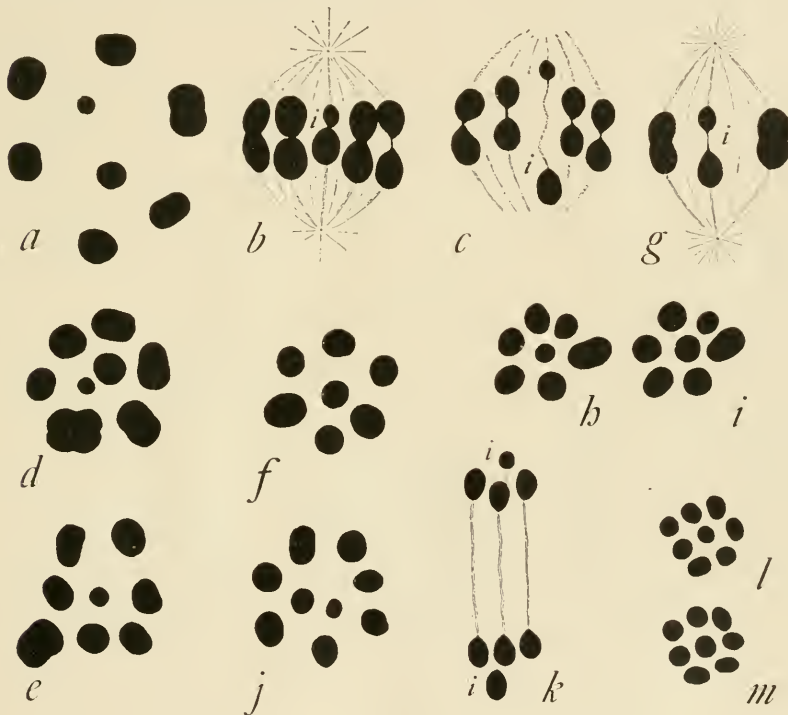

FIG. 3.

*Euschistus fissilis*, *Euschistus* sp., *Podisus spinosus*. *a-c*, *Euschistus fissilis*. *a*, metaphase-group, first division; *b, c*, metaphase-figure, and early anaphase in side view, second division. *d-i*, *Euschistus* sp.; *d, e*, metaphase groups, first division; *f*, metaphase-group, second division; *g*, second division, side view; *h, i*, daughter-groups, late anaphase of second division, from the same spindle; *j-m*, *Podisus spinosus*; *j*, metaphase-group, first division; *k*, late anaphase, second division; *l, m*, daughter-groups from the same spindle, late anaphase, second division.

In *Euschistus*, *Brochymena*, *Podisus* and *Trichopepla* the facts are, with a few variations of detail, essentially similar. In both species of *Euschistus* and in *Brochymena* the number of chromo-

somes agrees with that of *Lygaeus*, being 14 in the spermatogonia, eight in the first spermatocyte-division, and seven in the second, and their grouping is similar (Figs. 3, 7), save that in *Brochymena*, alone among all the forms, the small idiochromosome frequently lies in the outer ring (Fig. 7*k*). *Podisus* differs only in the fact that the numbers are respectively 9 and 8 (Figs. 3*j*, *l*, *m*), while the spermatogonial number is 16 instead of 14 (Fig. 5*k*). *Trichopepla* is a puzzling case which I have not yet fully cleared up. The daughter-groups of the second division show 7 chromo-

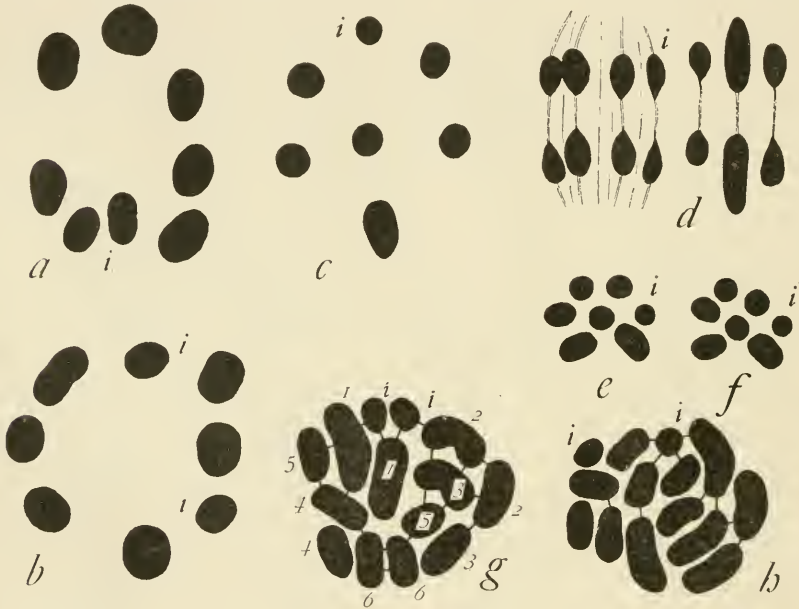

FIG. 4.

*Nezara*. *a*, *b*, metaphase-groups, first division; *c*, metaphase-group, second division; *d*, entire chromosome-group, second division, in side view, showing equal division (three chromosome-pairs from a lower level of the spindle shown at the right); *e*, *f*, duplicate sister chromosome-groups, anaphase of second division, from the same spindle; *g*, *h*, spermatogonial metaphase-groups.

somes each (Fig. 7*q*, *r*), the idiochromosomes being well differentiated. The first division, however, agrees with Montgomery's description in showing either 9 (Fig. 7*o*) or 8, the smallest chromosome being in the latter case wanting.

The conditions in *Nezara* are of particular interest from a comparative point of view in that *the idiochromosomes are of equal*



size. The first spermatocyte-division shows 8 chromosomes, which differ in grouping from that of the other forms in that all usually lie in a ring without a chromosome at its center (Fig. 4 *a, b*). For this reason no clue to the identification of the idiochromosomes is given by their position. Two of the chromosomes are, however, distinctly smaller than the others; and the relations in the spermatogonia leave little doubt that it is these two that correspond to the idiochromosomes. They may lie side by side (Fig. 4*a*) or more or less widely separated (4*b*). All these chromosomes are, in side view, seen to have a symmetrical dumb-bell shape, and all are equally halved in the first division. None of the preparations show the stage immediately following; but there can be no doubt that a conjugation of the two small chromosomes takes place at this time, since the second division (of which I have a large number) invariably shows in polar view but 7 chromosomes, which have now assumed the usual arrangement, with one in the center of a ring formed by the 6 others (Fig. 4*c*). Nezara differs again, however, from all the other forms in the fact that the small chromosome (*i. e.*, the idiochromosome-dyad) lies in the outer ring, in many if not in all cases, while one of the larger chromosomes lies at the center of the ring. Lateral views of the spindle show all of the chromosomes as quite symmetrical dyads; and in the ensuing division all divide equally (Fig. 4*d*). In such views the idiochromosome-dyad, which is readily recognizable by its size, may be clearly seen to divide equally; and in this respect Nezara differs from all the others. The anaphase sister-groups of the same spindle, each containing 7 chromosomes (Fig. 4*e, f*) are, accordingly, exact duplicates, the idiochromosome retaining its position in the outer ring.

The symmetrical division of the idiochromosome-dyad in Nezara is a fact of importance for the comparison of the idiochromosomes with the microchromosomes of such forms as Anasa or Alydus. Were it not for their failure to unite to form a bivalent body until the end of the first mitosis we should find no ground in this case for designating these chromosomes by a special name.

## 2 The Spermatogonial Chromosomes.

We have now to examine the relation of the chromosomes of the first maturation to those of the spermatogonia. The material

for the spermatogonial division is most abundant in the case of *Lygæus*, which is much the most favorable form for an accurate count, the chromosomes being well separated and showing with almost schematic clearness. In the preparations of this form numerous spermatogonial plates appear, showing, whenever an accurate count can be made, without exception 14 chromosomes (Fig. 5*g*, *b*). *Nezara*, of which numerous spermatogonial divisions are also available, shows the same number and with almost equal clearness, though the chromosomes are in this form more crowded. In the other forms the material is less abundant, but the relations are clearly shown in most of them. *Cœnus* (Fig. 5*i*) *Euschistus* (Fig. 5*j*), and *Brochymena* (Fig. 7*n*) also show 14 spermatogonial chromosomes, while in *Podisus* (Fig. 5*k*) the number is 16.<sup>1</sup> In all these cases, therefore, the spermatogonial number is double that of the chromosomes in the second spermatocyte-division, and two less than double the number in the first division. The most striking fact is that in all these forms, with the exception of *Nezara*, the spermatogonial groups show but one microchromosome (marked *i* in Figs. 4, 5, 7); in striking contrast to the fact first determined by Paulmier in *Anasa* and afterward by Montgomery in many other Hemiptera, that two such bodies ("chromatin-nucleoli" of Montgomery) equal in size, are often present. Did this observation rest only on the examination of a few division-figures (as in the case of *Cœnus*, *Euschistus*, *Podisus* and *Brochymena*) I should hardly trust in its general applicability to the species; but in *Lygæus* numerous demonstrative cases remove every doubt regarding this point, and the agreement of the other forms in their later history makes it nearly certain that my observation is not at fault with them.<sup>2</sup>

Distinct, though not very great, size-differences may be observed in the larger spermatogonial chromosomes, as has been indicated by Montgomery in several other genera of Hemiptera. Though these differences are not nearly as marked as those recognized by Sutton in *Brachystola*, it is nevertheless pretty clearly evident

<sup>1</sup>Montgomery ('01, 1) gives the numbers as follows: *Euschistus variolarius* 16, *E. tristigmus* 14, *Nezara* 16, *Cœnus* 14, *Brochymena* 16, *Podisus* 16.

<sup>2</sup>This point is emphasized since Montgomery describes and figures two spermatogonial microchromosomes ("chromatin-nucleoli") in *Euschistus variolarius* ('01, 1, Figs. 2, 3), *E. tristigmus* (*op. cit.*, Fig. 20), *Cœnus delius* (Fig. 55), and *Brochymena* (Fig. 47). One of the figures of the first-named species shows them equal, the other unequal, in size.

that the larger chromosomes may be grouped in six pairs; and in Figs. 5*b*, *i*, *j*, 4*g*, 7*n*<sup>1</sup> I have attempted to indicate these by corresponding numbers; though no pretense to complete accuracy of identification can be made, since the chromosomes vary somewhat in form and their apparent sizes vary somewhat with their position, owing to foreshortening. Allowing for all errors of identification it is obvious that in all but *Nezara* 12 of the larger chromo-

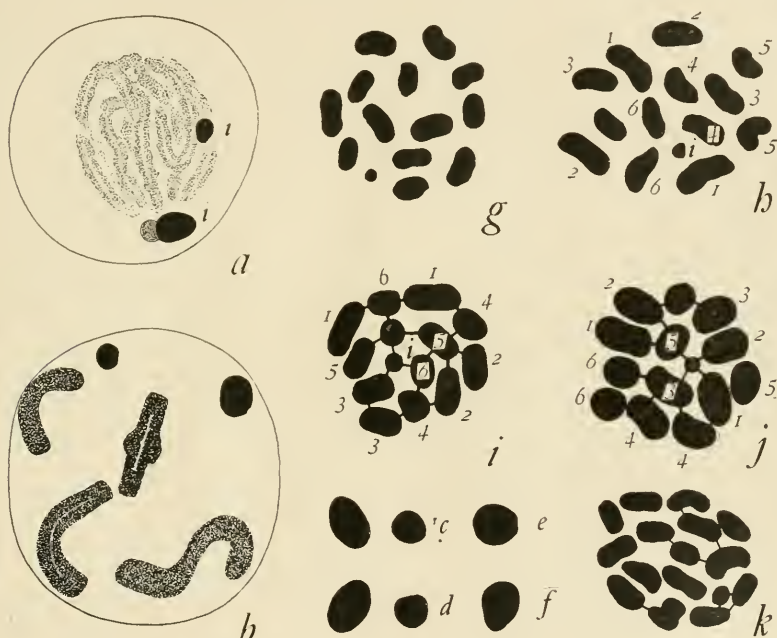

FIG. 5.

*Cœnus* (*a-f*, *i*), *Lygæus* (*g*, *h*), *Euschistus* (*j*), *Podisus* (*k*). *a*, *Cœnus*, contraction-phase, showing both idiochromosomes in the form of chromosome-nucleoli; *b*, prophase, corresponding to stage *h* in *Lygæus*, the two idiochromosomes and four of the others; *c-f*, chromosome-nucleoli of *Cœnus* from a stage corresponding to stage *f*; *c*, *d*, both idiochromosomes present, *e*, *f*, single chromosome-nucleoli; *g*, *h*, spermatogonial metaphase-groups, *Lygæus*; *i*, spermatogonial group, *Cœnus*; *j*, spermatogonial group, *Euschistus*, sp.; *k*, spermatogonial group, *Podisus*.

somes may be symmetrically paired off, two by two, while a thirteenth (unnumbered in the figures) is left without a fellow of like size. The conclusion is, I think, irresistible that in synapsis

<sup>1</sup>In the last figure the chromosomes have been by inadvertence wrongly lettered.

twelve of the larger chromosomes unite to form the six peripheral bivalents of the first division, that the thirteenth is the larger idiochromosome and the fourteenth (the microchromosome) the small idiochromosome. These two alone remain separate in the first division as univalent chromosomes, thus giving a group of eight instead of seven. This conclusion is in accordance with Montgomery's interpretation of the facts observed by him in *Euchistus tristigmus*, as pointed out beyond, except that he believed that in this form the first division might in many cases show only seven chromosomes, the "chromatin nucleoli" having, like the other chromosomes, already conjugated to form a bivalent body. My interpretation is strikingly confirmed by the facts observed in *Nezara*; for in this case, where the first spermatocyte-division shows two chromosomes of equal size and the smallest of the group, *the spermatogonia correspondingly show two equal microchromosomes*, as in *Anasa*, *Alydus*, or *Protenor* (Fig. 4*g, b*). Since these two are represented in the second division by a single symmetrical dyad, which is again the smallest of the group (Fig. 4 *g-f*) it is evident that the two equal microchromosomes must conjugate after the first division. They therefore agree in behavior with the unequal idiochromosomes present in the other forms, and differ from those of the *Anasa* type, in remaining separate during the first maturation-mitosis.

### 3. *The Growth-Period of the Primary Spermatocytes.*

#### (a) General History.

It is not my purpose to describe in detail at this time the general history of the chromatin during the growth-period, but it will be convenient to outline the stages in order to trace the history of the idiochromosomes. In *Lygæus* ten well marked stages may be distinguished from the early synapsis (*a*) to the metaphase of the first division (*j*), inclusive. Though some of these stages are best characterized by the condition of the idiochromosomes, an account of the latter can more readily be given after considering the history of the larger chromosomes. In stage *a* (early synapsis), which shortly follows the final anaphase of the last spermatogonial division, the chromosomes have the form of rather ragged, longitudinally split loops, the free ends of which converge toward

one pole of the nucleus. In stage *b* (contraction-phase, Fig. 6*a*) they become closely massed in a spheroidal aggregation at the center or toward one side of the nucleus, and surrounded by a large clear space. At this time they stain so deeply that their



FIG. 6.

*Lygaeus turcicus*. *a*, contraction-phase of synaptic period (stage *b*) showing large idiochromosome; *b*, early post-synapsis (stage *c*), both idiochromosomes shown; *c*, stage *d*, a plasmosome connected with the large idiochromosome; *d-f*, chromosome-nucleoli (with plasmosome) from stage *e*; *d* and *e* single, *f*, showing the two idiochromosomes; *g*, stage *f*, with plasmosome at its maximum size, and both idiochromosomes; *h-n*, chromosome-nucleoli from stage *f* (represented side by side near the plasmosome, out of their natural position); *h-k*, four cases in which but one is present, *l-n* showing both idiochromosomes; *o*, stage *g*, with both idiochromosomes; *p, q*, stage *h*, two sections of the same nucleus showing all of the eight chromosomes and a small plasmosome; *r*, stage *i*, showing the six larger chromosomes and the two idiochromosomes.

outlines can only with difficulty be made out, and then only after long extraction. In stage *c* (early post-synapsis) they again spread through the nuclear cavity, giving the appearance of an interrupted, contorted and more or less confused spireme, composed of delicate and somewhat varicose threads (Fig. 6*b*). In stage *d* (Fig. 6*c*) the threads become somewhat shorter and thicker and have a more open arrangement, but still show a very marked spireme-like arrangement. I believe the threads to be at this period longitudinally split, though this can only be made out with difficulty. This stage is well characterized by the condition of the large idiochromosome, as described beyond, and by the appearance of a pale plasmosome. In stage *e* the threads become markedly shorter and thicker, ragged in outlines, often faintly show a longitudinal split, and diminish somewhat in staining-capacity. The chromosomes now undergo a great change, becoming in stage *f* very loose in texture, showing only vague boundaries, and almost completely losing their staining-capacity, so that it is difficult to represent their appearance in a black and white figure (Fig. 6*g*). As may be seen from the figure the chromosomes now give the appearance of a rather vague, pale, finely granular network, in which traces of a spireme-like arrangement can usually be seen, but they cannot be clearly made out as individual bodies. Stage *g* again shows a great change (Fig. 6*o*) the chromosomes having resumed their staining capacity and definite boundaries, and now appearing as long, coarse, winding threads, often showing rather ragged outlines and a more or less distinct longitudinal split, as in stage *e*; the two stages may, however, at once be distinguished both by the position of the cells in the testis and by the different relation of the plasmosome and the chromosome-nucleoli, as described below. The condensation of the chromosomes now takes place, the succeeding three stages following in rapid succession. In stage *h* the long split rods shorten and thicken, stain much more deeply, and assume a great variety of forms—curved double rods, dumb-bell shaped figures (sometimes longitudinally split), closed rings, and peculiar cross-forms. (Fig. 6*p*, *q*, which show all the chromosomes from a single nucleus.) In stage *i* (early prophase) all these forms condense into quadripartite tetrads or dyad-like bodies, the latter consisting of two symmetrical halves closely joined together and frequently showing no trace of a second division, though in the same nucleus

may occur one or more distinctly quadripartite forms (Fig. 6r). The history of these dyad-like bodies clearly shows, I think, that with the exception of the idiochromosomes they are derived from bivalent longitudinally split rods, and they have therefore the same valence as the actual tetrads with which they are associated. The nuclear membrane now disappears and the chromosomes are drawn into the equatorial plate of the first mitosis.

The general history of the growth-period in *Cœnus* is similar to that of *Lygæus*, but is in some respects abbreviated; and stage *f* is much less marked, the chromosomes not losing their boundaries or their staining-capacity in so great a degree, and still presenting the appearance of a ragged interrupted spireme.

(b) The Idiochromosomes during the Growth-period.

The foregoing description applies only to the larger or ordinary chromosomes. Throughout the whole of the growth-period in *Cœnus* and from stage *e* onward in *Lygæus*, at least one of the idiochromosomes can always be distinguished as a compact, spheroidal, intensely staining chromosome-nucleolus, and frequently both idiochromosomes are distinguishable in this form in all of these stages. The early stages of *Lygæus* (*b* to *d*) are of especial interest in that the condensation of the idiochromosomes is delayed, and at least the larger one still has the form of an elongate, longitudinally split rod or thread. Even at this time, however, it is immediately distinguishable from the others by its greater thickness and greater staining capacity. It is clear beyond all question, therefore, that at least the large idiochromosome may retain its identity throughout the whole growth-period. With the small idiochromosome the case is not so strong, as will be seen from the following account.

It is convenient to trace the history of the idiochromosomes in the reverse order from stage *i* backward, again taking *Lygæus* as the type. In this stage (late prophase), when the six larger chromosomes are in the form of condensed tetrads or dyad-like bodies, both the idiochromosomes have very distinctly the form of dyads. The nucleus now contains therefore eight separate chromosomes, among which the idiochromosomes are at once recognizable by their small size (*6r*). In stage *b* the idiochromosomes have the same general appearance, though their bipartite

form is often less distinct (6g). Up to this point both idiochromosomes are apparently always present. In the stages now to be considered both are often plainly distinguishable, but quite as frequently this is not the case, the nucleus showing but a single chromosome-nucleolus the size of which proves it to be either the large idiochromosome or the large and small one united. Between these two possibilities I have not been able to decide in *Lygæus* and *Cœnus*; but decisive evidence is given in the case of *Brochymena*, as described beyond. In stage *g* (6o) the idiochromosomes (or the single chromosome-nucleolus) appear as spheroidal compact bodies, usually not showing a bipartite structure, and in addition one or more pale rounded plasmosomes are often present. In stage *f*, owing to the loss of staining capacity by the larger chromosomes, the idiochromosomes show with brilliant clearness, since they are still stained intensely black, and may very readily be studied with care (6g-n). When both are present they appear slightly larger than in the later stages, and often the larger one is plainly seen to be hollow (which probably accounts for its larger size) though this is shown still more clearly in *Brochymena*, as described beyond. A small plasmosome is sometimes attached to it at one side, but in addition to this there is always present a very large pale plasmosome quite free from both idiochromosomes, and free also from the single chromosome-nucleolus when but one of these bodies is present. In stage *e* the idiochromosomes present the same appearance, but the *larger one is now always attached to the large plasmosome*, and often more or less flattened against it (as is also the single chromosome-nucleolus when but one appears) while the small one is almost always free from it (Fig. 6d, e, f). The larger body is as before often evidently hollow.

Up to this point *Lygæus* and *Cœnus* agree almost exactly. In the earlier stages they differ in that *Cœnus* still shows the idiochromosomes in the form of compact chromosome-nucleoli, while in *Lygæus* the larger one certainly, and I believe the smaller one also, assumes the form of a longitudinally split elongate chromosome. In stage *d* in *Lygæus* (Fig. 6c) the large idiochromosome is a rather short, deeply staining rod, longitudinally split, and still attached (usually toward one end) to the plasmosome, which is now considerably smaller. The small idiochromosome is now also more or less elongate, but I cannot be sure whether it



is longitudinally split. All intermediate stages may readily be observed between this stage and the next earlier one (*c*) in which the large idiochromosome is an elongate split thread that may extend through more than half the diameter of the nucleus (Fig. 6*b*). It is, however, at once distinguishable from the other chromosomes by its straighter course, greater thickness and deeper staining capacity,<sup>1</sup> which renders it very conspicuous among the thread-like chromosomes. No plasmosome can now be seen. The small idiochromosome can still clearly be distinguished in many of the nuclei as a short rod staining like the larger one. Finally, in the contraction-phase (stage *b*) when all the chromosomes are massed together, the large idiochromosome still unmistakably appears as a very distinct deeply staining rod, sometimes nearly straight, more usually curved, and frequently horse-shoe shaped, at one side of the chromosome-mass (6*a*). Neither plasmosome nor small idiochromosome can now be made out. In *Cœnus* at this period (Fig. 5*a*) both idiochromosomes (or the single chromosome-nucleolus) still appear as compact, deeply staining spheroidal bodies, the larger one typically having a small plasmosome attached to it at one side.

The early history of the large idiochromosome proves most clearly that the chromosome-nucleolus into which it afterward condenses is a modified chromosome (as Montgomery first showed in *Euschistus variolarius*) and one that forms a connecting link between the ordinary chromosomes and the more usual forms of "chromatin-nucleoli" in Hemiptera, described by Montgomery, or the accessory chromosome of Orthoptera; for in none of these latter is the condensation to a compact body so long delayed. Paulmier ('99) showed, however, that in *Anasa* the compact chromosome-nucleolus of the synaptic period, afterward elongates considerably and appears as a rather short longitudinally split rod, similar to that of *Lygæus* at stage *d* (Paulmier, Fig. 22) afterward again condensing into a compact tetrad. In *Lygæus* there can be little doubt that the central cavity of the spheroidal chromosome-nucleolus, often visible in stages *e-g*, represents the original longitudinal split. It is therefore hardly open to doubt that the division of the large idiochromosome in the first mitosis is an equational-division, and the same is probably true of the small

<sup>1</sup>This has been somewhat exaggerated in the engraving.

idiochromosome. It is, on the other hand, quite certain that the division of the idiochromosome-dyad in the second mitosis is a reduction-division. The order of the divisions in case of the idiochromosomes is thus the reverse of that which occurs in the other chromosomes, according to Paulmier's and Montgomery's accounts; and as pointed out beyond, it is also the reverse of that which takes place in the division of the small central chromosome in *Anasa* and *Alydus*.

As already stated, I did not in *Lygæus* and *Cœnus*, succeed in finding any certain explanation of the fact that the nuclei of the growth-period may show either one or two chromosome-nucleoli.

In *Brochymena*, however, there is very clear evidence on this point. Here, too, the nuclei of the middle growth period show either one or two spheroidal chromosome-nucleoli, the former condition being much the more frequent. When both are present they may be widely separated or close together, and both very clearly show a central cavity, which is rendered very conspicuous by the fact that the chromatin is frequently concentrated in a dark zone immediately around it (Fig. 7*c-g*). When but one is present it is, as a rule, perfectly spherical, hollow, and shows no evidence of a double nature (Fig. 7*f, g*). In the early growth-period, however, the single chromosome-nucleolus almost always appears bipartite, being composed of two unequal halves, forming an asymmetrical dyad (Fig. 7*a, b*) very similar to that seen in the second maturation-division (Fig. 7*m*). At a later period both of the constituents become hollow (and hence appear somewhat larger) and stain less deeply; and all gradations may be observed in the fusion of the two bodies to form a single hollow body (Fig. 7*c, d, f*) which is plainly as large as the two separate chromosome-nucleoli (such as may be seen in cells of the same cyst) taken together. In *Brochymena*, therefore, there can be no doubt that *when only one chromosome-nucleolus is present it is to be considered as a bivalent body arising by the fusion or synapsis of the two idiochromosomes.*

Thus far the facts confirm the interpretation given by Montgomery ('01, 1) who observed in *Cœnus*, *Euschistus tristigmus* and some other forms that the cells of the growth-period may show either a single "chromatin-nucleolus" or (in *Euschistus* "apparently more frequently") two such bodies that are unequal in size; and this fact he interpreted to mean that the two corresponding

spermatogonial "chromatin-nucleoli" may either conjugate at the period of general synapsis to form a bivalent body or may remain separate as univalent bodies. As already pointed out, it was probably this interpretation that led him to conclude that the first division in these forms might show either seven or eight chromosomes. But the later stages observed in *Brochymena* give conclusive evidence that even though such a primary synapsis

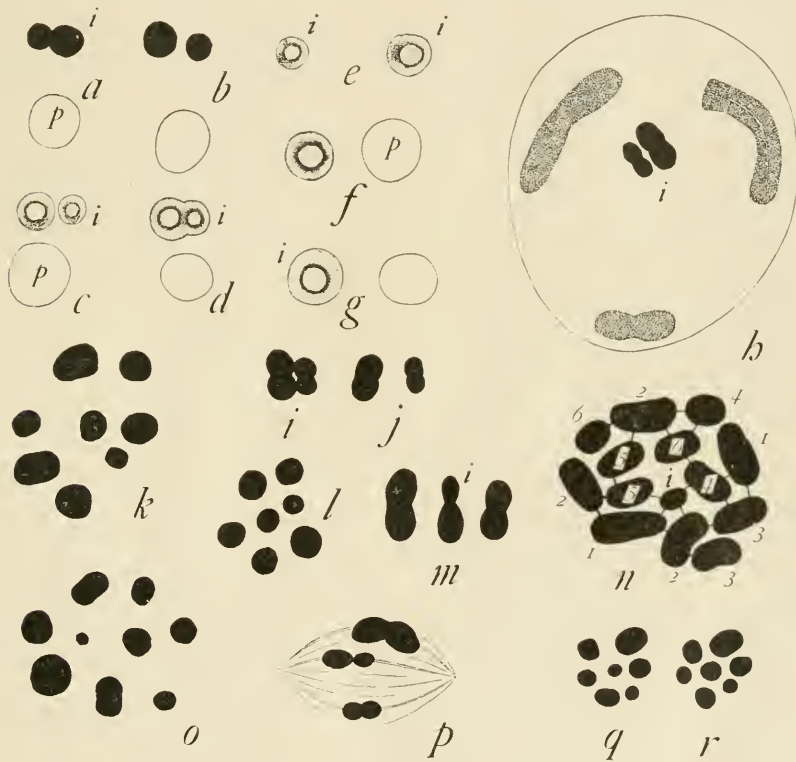

FIG. 7.

*Brochymena*, *Trichochepla*. *a-n*, *Brochymena*, *o-r*, *Trichochepla*; *a, b*, idiochromosomes and plasmosomes, from early growth-period; *c-g*, condition of the idiochromosomes in middle and late growth-periods; *h*, prophase of first division, showing idiochromosome-tetrad; *i, j*, two stages, one following and one preceding the last, in the division of the bivalent chromosome-nucleolus; *k*, metaphase-group, first division; *l*, metaphase-group, second division; *m*, side view, second division, showing idiochromosome-dyad and two other chromosomes; *n*, spermatogonial metaphase-group; *o*, metaphase-group, first division, *Trichochepla*; *p*, spindle of second division in lateral view; *q, r*, sister-groups, late anaphase of second division.

of the idiochromosomes takes place *the bivalent chromosome-nucleolus again separates into its univalent constituents in the early prophases of the first maturation-division*. This process, which at first greatly puzzled me, occurs at the time just preceding the concentration of the larger chromosomes into their final condensed form (corresponding to stage *b* in Lygæus). In cysts of this period every stage may be seen in the transformation of the single chromosome-nucleolus into an asymmetrical tetrad, consisting of two symmetrical dumb-bell shaped bodies of unequal size (Fig. 7*i*), and the separation of these unequal dyads to form the idiochromosomes of the first division (*cf.* Figs. 7*b, i, j*). It is evident that in these cases the final reunion or conjugation at the end of the first division is not a primary synapsis, but a secondary process.<sup>1</sup>

The facts observed in *Brochymena* make it very probable that when only a single chromosome-nucleolus is present in Lygæus, *Cœnus* and the other forms, it is there also a bivalent body as Montgomery assumed; but the uniform separation of the idiochromosomes in the first division of all the eight species I have examined is almost a demonstration that in all the forms a division of the bivalent body must occur. On the other hand it seems equally certain that in many of these forms the idiochromosomes may fail to unite at the period of general synapsis, and may remain separate through the whole growth-period; and in *Brochymena* the same cysts that show the division of the single idiochromosome-tetrad may also contain nuclei in which the dumb-bell shaped idiochromosomes are widely separated. In such cases it seems probable that the conjugation of the idiochromosomes at the close of the first spermatocyte-division must be regarded as a true or primary synapsis that has been deferred to this late period.

#### DISCUSSION OF RESULTS.

The most essential fact brought out by a study of the idiochromosomes is that in Lygæus, *Cœnus*, *Podisus*, *Euschistus*, *Brochymena* and *Trichopepla* a dimorphism of the spermatozoa exists, there being two groups equal in number, both of which contain

<sup>1</sup>The division of the bivalent chromosome-nucleolus is similar to the process described by Gross ('04) in *Syromastes*; though it occurs at a much later period. For reasons that will appear in a subsequent paper, I am, however, skeptical in regard to Gross's conclusion which is based on a study not of the idiochromosomes but of paired microchromosomes similar to those of *Anasa* or *Alydus*.

the same number of chromosomes, but differ in respect to one of them. In this respect these genera differ from all those that possess an accessory chromosome (*Pyrrochoris*, *Anasa*, *Alydus*, etc.), since in the latter case one-half of the spermatozoa receive one chromosome fewer than the other half. It is remarkable that two types of dimorphism apparently so different should coexist within the limits of a single order of insects. We are thus led to inquire into the relation between the idiochromosomes and the accessory; and this inquiry must also include the "small chromosomes" of Paulmier and the "chromatin-nucleoli" of Montgomery. It will conduce to clearness if the second part of this question be considered first.

It is evident from the figures and descriptions of Montgomery ('98, '01, 1, '01, 2, '04) that the bodies I have called idiochromosomes are identical with some of those that this author has described under the name of "chromatin-nucleoli" (which are usually also small chromosomes or microchromosomes); but it is now manifest that the bodies described under the latter name are not all of the same nature. It is evident that two types of these bodies may be distinguished that differ markedly in their behavior during the maturation-mitosis. One of these, typically represented in *Anasa*, *Alydus* and *Protenor* appear in the spermatogonia in the form of two equal microchromosomes ("chromatin-nucleoli") which like the other chromosomes sooner or later unite in synapsis to form a bivalent body that lies at the center of the equatorial plate of the first mitosis. Both divisions accordingly show exactly one half the spermatogonial number of chromosomes but it is a very noteworthy fact that the final conjugation of the two microchromosomes is long deferred, taking place in the prophases of the first division (as was first observed by Montgomery in *Protenor* and some other forms, more recently by Gross in *Syromastes* and by myself in *Anasa* and *Alydus*). In this case there seems to be no doubt that the first division of the bivalent body thus formed is a reducing division. It appears to be further characteristic of this type—at least in all the forms mentioned—that a true accessory chromosome is associated with the microchromosomes, and that only one-half of the spermatozoa receive one-half the somatic number of chromosomes, the other spermatozoa receiving one less than this. The distinction between the accessory and the microchromosomes or "chromatin-nucleoli" first demonstrated

by Montgomery ('01) in *Protenor*, has been more recently shown by Gross ('04) to exist in *Syromastes*; and I have also been able to demonstrate the same fact in *Alydus* and in *Anasa* (Paulmier having been in error in his identification of the accessory with the small chromosome in the last-named form).

The second type includes the idiochromosomes, which in the forms I have studied differ from the *Anasa* type in four respects (*Nezara* being an exception in regard to the first of these), namely, (1) in their unequal size, with which is correlated the fact that only a single microchromosome appears in the spermatogonia; (2) in the fact that the final conjugation or synapsis of these bodies is deferred until the prophases of the *second* division, a result of which is that the first division shows one more than half the spermatogonial number of chromosomes while the second division shows exactly half the spermatogonial number; (3) in the fact that in case of the idiochromosomes it is manifestly the second division that is the reducing one, while my observations on *Lygæus* render it practically certain that the first is an equation-division; (4) in the fact that no accessory chromosome in the usual sense is present and all the spermatozoa receive the same number of chromosomes. In view of these differences it seems expedient for the present to place these two types in different categories.

It is evident from Montgomery's figures and descriptions that he observed many of the details of the phenomena described in the present paper; but it is equally clear from the varying interpretations that he adopted that he failed to reach any consistent general result regarding the behavior of the idiochromosomes, or to recognize the dimorphism of the spermatozoa. For example, it is evident, I think, from his descriptions of *Euschistus variolarius*, *E. tristigmus*, *Cœnus delius*, *Oncopeltus fasciatus*, and *Lygus pratensis*, that the essential facts in these forms agree with those I have described, the idiochromosomes being in the last named two species of equal size, as in *Nezara*; but Montgomery offers for each of these cases a different interpretation. In the first named species the idiochromosomes are clearly figured in his first paper ('98, Figs. 171, 188, 189, etc.), and in Fig. 214 they are shown separating in quite typical fashion in the second division (the smaller one designated as a "chromatin-nucleolus"); but it is evident from the descriptions given in both this and the following paper ('01, 1) that he did not reach a correct interpretation of the

facts.<sup>1</sup> In *Euschistus tristigmus* and *Cœnus delius* the first division is stated to show either seven or eight chromosomes (the spermatogonial number being 14), but quite different interpretations are given of this in the two species, the conditions in *Euschistus* being assumed to be due to the frequent failure of the two "chromatin nucleoli" to unite in synapsis, while in the case of *Cœnus* seven of the chromosomes (including the large "chromatin-nucleolus") are assumed to be bivalent, while the eighth is an additional small "chromatin-nucleolus" not distinguishable in the spermatogonia ('01, 1, p. 166). In *Euschistus tristigmus* the "chromatin-nucleoli" are stated to be of unequal size and to be separated from each other without division in the second mitosis. This is evidently the same phenomenon that I have described; though Montgomery overlooked the conjugation of the two unequal "chromatin-nucleoli" at the end of the first division, and expressly states that they are not joined together in the second division. In *Oncopeltus*, likewise, the first division shows one more than half the spermatogonial number, 16 (*i. e.*, nine instead of eight, precisely as I have described in *Podisus*), and this is stated to result from the persistence of the two "chromatin-nucleoli" throughout the whole growth period without union; but an interpretation differing from both the foregoing is here sought in the assumption that each of the two "chromatin-nucleoli" is bivalent, even in the spermatogonia ('01, 1, p. 186). In *Lygus pratensis*, finally, the first division shows 18 chromosomes and the second 17, the still different explanation being here offered that the two "chromatin-nucleoli" pass undivided one to each pole of the first spindle ('01, 1). Of these various interpretations only the one given in the case of *Euschistus tristigmus*, I believe, con-

<sup>1</sup>The first mitosis is here clearly shown to have eight chromosomes, grouped in the same way as in my "*Euschistus* sp." and the anaphase daughter-plate of the second division is shown with seven (Fig. 220), precisely as in the two species I have studied. Montgomery gave the spermatogonial number, correctly I believe, as 14. He nevertheless concluded that all of the eight chromosomes (seven chromosomes + 1 "chromatin nucleolus") divide separately in both divisions, apparently overlooking the fact that this would give the spermatozoa one chromosome too many (since he himself demonstrated that the "chromatin-nucleolus" is a modified chromosome). This account of the divisions is not modified in the paper of 1901 except in the statement that "in the second maturation-division the chromatin-nucleolus is not always divided" (p. 161), while the spermatogonial number is now given as 16. Since the figures of the earlier paper show that the divisions in *E. variolarius* are evidently the same as in the species I have examined, I think that on both these points the first account was probably more accurate than the later one.

forms to the true one, and it is probable that all of these cases will be found to agree in the essential phenomena with those I have determined in *Lygæus*, *Cœnus*, *Nezara* and the other forms.

We may now inquire what is the relation of the idiochromosomes to the accessory chromosome. The observations suggest so obvious an answer to this question that I wish to indicate not only the evidence in its favor, but more especially the difficulties it has to encounter. In forms possessing an accessory chromosome the spermatozoa fall into two equal groups that differ only in respect to one chromosome. The same is true of *Lygæus* and other forms that lack the accessory but possess the idiochromosomes, with the difference that in the former case the distinctive chromosome is present in but one-half the spermatozoa, while in the latter case two such distinctive chromosomes are present, one of which is present in one-half, the other in the other half, of the spermatozoa. It is impossible to overlook the evident analogy between the two cases; and the idiochromosomes may in one sense be considered as two accessory chromosomes that are never allotted to the same spermatozoön since each fails to divide in the second mitosis (precisely as is the case with the single accessory in other Hemiptera). The difference between *Lygæus* and *Cœnus* in the size-ratio of the idiochromosomes obviously suggests the view that the single accessory of other forms may have arisen by the disappearance of one of the idiochromosomes; and in *Lygæus* the smaller one is already so minute as distinctly to suggest a vestigial structure. We might accordingly assume that in a more primitive type the two idiochromosomes were of equal size (as in *Nezara*), undergoing synapsis and subsequent reduction in the same way as the other chromosomes; that *Cœnus* and *Lygæus* represent successive stages in the reduction of one of these chromosomes; and that by the final disappearance of the smaller one in such forms as *Anasa* or *Pyrochoris* a single accessory chromosome remains.

This hypothesis at first sight seems to give a clear and intelligible view of the origin of the accessory chromosome, and to reconcile the remarkable mode of spermatogenesis occurring in the insects with forms in which no accessory seems to appear. But further reflection shows that it has to encounter a formidable if not insuperable difficulty in the fact that in some of the forms possessing an accessory chromosome the number of spermato-



gonial chromosomes is an even one (as in *Anasa* and *Syromastes*); and there seems to be no escape from the conclusion that the accessory is here a bivalent body arising by the synapsis of two equal spermatogonial chromosomes. Even in cases showing an odd number of spermatogonial chromosomes (as in many Orthoptera and some Hemiptera—for example *Alydus* or *Protenor*) it has been assumed, and with good reason, that one of the chromosomes (probably the accessory) is already bivalent,<sup>1</sup> and Montgomery has shown ('01, 1) that in *Protenor* the large accessory ("chromosome x") is sometimes transversely constricted into two equal halves in the spermatogonia. A similar fact was subsequently shown in *Harmostes* ('01, 2) which also has normally an odd spermatogonial number. To this should be added the fact that these forms possess the small bivalent central chromosome (which arises by the synapsis of two equal microchromosomes) in addition to the accessory. The difficulty pointed out above cannot be escaped by supposing that the disappearance of one of the idiochromosomes has been effected by its gradual absorption by the other; for this assumption, too, fails to explain the even number of spermatogonial chromosomes. Apparently therefore the hypothesis I have suggested, must in the present state of our knowledge be considered untenable.<sup>2</sup>

It appears more probable that the idiochromosomes are comparable to the two equal microchromosomes or "chromatin-

<sup>1</sup>Cf. Montgomery, '04.

<sup>2</sup>Since this paper was sent to press I have determined beyond the possibility of doubt, I think, that the number of spermatogonial chromosomes in *Anasa tristis* is 21, not 22 as given by both Paulmier and Montgomery. This result is based on the study of a large number of preparations, and careful camera drawings of more than twenty perfectly clear metaphase figures have been made. All without exception show 21 chromosomes, and I have sought in vain for even a single cell that shows 22. (Paulmier's original slides were used.) If corroboratory evidence be needed it is given by the fact that there are always three macrochromosomes, one of which is obviously without a mate of like size, and is probably the accessory. I have, also, positively determined the spermatogonial number to be 21 in a form included in Paulmier's material and labeled "*Chariesterus antennator*," (since this number disagrees with Montgomery's count of the spermatocytes there may be an error of identification; but the form is certainly different from *Anasa*) and 15 in *Archimerus calcarator* (from my own material, identified by Mr. Uhler), both members of the same family as *Anasa*. This wholly unexpected result perhaps justifies a certain skepticism in my mind in regard to the accounts of other observers, who give an even spermatogonial number for forms possessing an accessory chromosome; and if this be well founded the objection urged above disappears. I shall return to this subject hereafter. It is needless to say that had I been acquainted with these facts, the discussion that follows would have been different.

nucleoli" which in such forms as *Anasa* or *Alydus* conjugate to form the small central chromosome of the first mitosis. The differences between the two forms have already been pointed out. Their resemblances are, however, no less obvious, namely, their usual central position in the equatorial plate, small size, occasional persistence as chromosome-nucleoli in the growth-period, and their late conjugation. This comparison finds very definite support in the conditions I have described in *Nezara*, where the idiochromosomes are of equal size and appear as two equal microchromosomes in the spermatogonia. From the analogy of other forms it is very probable that the more primitive and typical form of synapsis is that between chromosomes of like size. It is therefore probable that such a condition as that observed in *Nezara* is a less modified one than that in which the idiochromosomes are unequal; and that the latter condition has arisen through a secondary morphological differentiation of two chromosomes that were originally of equal size, and perhaps are represented by the two equal microchromosomes that appear in the spermatogonia of such Hemiptera as *Anasa*, *Alydus*, *Syromastes* or *Protenor*. This comparison involves two assumptions, namely, first that in case of the idiochromosomes the final conjugation of the microchromosomes has been postponed from the prophases of the first division to those of the second; and secondly that a reversal in the order of the reduction- and equation-divisions has taken place in case of these particular chromosomes, the first division being in case of the *Anasa*-type the reduction- and in case of the idiochromosomes the equation-division. The difficulty apparently involved by the second assumption is less serious than may appear. All the facts at our command indicate that a reduction-division is the necessary, or at least invariable, sequel to a foregoing conjugation; and if, as in the case of the idiochromosomes, the final conjugation is deferred to the second division, the reduction-division must also be deferred. The univalent idiochromosomes—as is shown with certainty in case of the larger one in *Lygæus*—undergo longitudinal division at the same stage of the growth-period as their bivalent companions and are already double at the time of the first mitosis. There is, therefore, no difficulty in the way of assuming—indeed, the facts seem to admit of no other conclusion—that this is the equation-division.

It must be recognized, however, that the foregoing comparison

wholly fails to explain the origin or meaning of the accessory chromosome, nor does it account for the surprising fact (of which the phenomena in *Brochymena* seem to leave no doubt) that two chromosomes may unite in synapsis, subsequently part company so as to divide as univalents in the first mitosis, but again conjugate to form a bivalent in the second mitosis. It seems likely that further comparative study of this phenomenon may throw important light on the general mechanism of karyokinesis and reduction.

The history of the idiochromosomes possesses a more general interest in the strong support that it lends to the general theory of the individuality of chromosomes, to the specific conclusions of Montgomery and Sutton in regard to synapsis, and especially to the correlation of the phenomena of reduction with those of Mendelian inheritance attempted by the last-named author ('02, '03). It has been assumed by some authors, including some of those who have accepted Montgomery's remarkable conclusion ('01, 1, '04) that corresponding paternal and maternal chromosomes unite in synapsis, that in this process the individuality of the conjugating chromosomes is completely lost—"Sie vereinigen sich zu einem einzigen Zygosom, aus dem erst wieder zwei neue Chromosomen hervorgehen."<sup>1</sup> It is undoubtedly true that frequently all visible traces of the duality of the bivalents that emerge from the synapsis stage are for a time lost; and as Sutton suggested ('03, p. 243), such cases as those of first crosses that breed true—and I may add, perhaps also those in which blended inheritance or weakening of dominance occurs—may be taken to indicate that a permanent fusion, or intermixture of the chromosome-substances, may really take place. But, on the other hand, the history of the idiochromosomes in cases where they remain separate through the whole growth-period leaves not the least doubt that as far as these particular chromosomes are concerned the same two that unite in synapsis persist as distinct individuals to be afterward separated by the reducing division and assigned to different germ-cells. This preliminary conjugation and subsequent separation ensures that the germ-cells shall be "pure" in respect to these particular chromosomes—*i. e.*, that both shall not enter the same spermatozoön—and if this be true of one pair of the conjugating chromo-

<sup>1</sup>Strasburger, '04, p. 26; *cf.* also Bonnevie, '05.

somes we have good reason to conclude that it may be true of all, as Montgomery has urged and as Sutton has so cogently argued, from a study of the size-relations. It is a fair working hypothesis that the idiochromosomes represent a pair of corresponding or allelomorphous qualities, or group of qualities, that are respectively maternal and paternal, as Sutton, building on the basis laid by Montgomery and himself, has argued for the chromosome-pairs in general. The argument of Montgomery and Sutton is based, it is true, on the fact that chromosomes of different sizes in the spermatocytes are represented by symmetrical chromosome-pairs of corresponding sizes in the spermatogonia; and to this the idiochromosomes in most of the cases described form an exception in being unequal. If this appears to be a difficulty it is removed by the case of *Nezara*, where the idiochromosomes are of equal size. Even in the more usual case, where they are unequal, symmetrical synapsis takes place between all the other chromosome-pairs. If the theory of the individuality of chromosomes be granted no other conclusion seems possible, accordingly, than that the remaining two, despite their size-difference, are respectively the paternal and maternal elements of the remaining pair; and if Sutton's general hypothesis be well founded, these elements may be assumed to be physiological correlates or allelomorphs. Their marked difference in size suggests a corresponding qualitative differentiation, and this inevitably suggests a possible connection between them and the sexual differentiation. The visible dimorphism of the spermatid-nuclei in such forms as *Lygæus*, *Cœnus* or *Podisus* shows too obvious a parallel to the sexual dimorphism of the germ-cells, indicated by so much of the recent work on sex-determination, to be ignored; while in *Nezara*, where no visible dimorphism exists, the spermatozoa nevertheless fall into two equal groups in respect to the previous behavior of one of the chromosomes. But such a suggestion as to the possible significance of the idiochromosomes immediately encounters the difficulty that both idiochromosomes are present in the male cells (spermatogonia, and spermatocytes), just as McClung's similar hypothesis regarding the accessory chromosome is confronted with the fact, determined by Montgomery and Gross, that in the Hemiptera both sexes show the same number of chromosomes. Whether these difficulties can be met by assumptions of dominance and the like remains to be seen; but the fact should be recognized

that as far as the Hemiptera are concerned neither the suggestion I have made, nor the hypothesis of McClung has at present any direct support in observed fact.<sup>1</sup>

The practical interest of the idiochromosomes lies in the very definite basis that they give for an examination of the question by the study of fertilization, for their disparity in size gives us the hope of determining their history by direct observation. There is good reason to believe that such a study will yield interesting results.

#### SUMMARY OF OBSERVATIONS.

1. In *Lygæus turcicus*, *Cœnus delius*, *Euschistus fissilis*, *Euschistus* sp., *Brochymena*, *Nezara*, *Trichopepla* and *Podisus spinosus* all of the spermatids receive the same number of chromosomes (half the spermatogonial number), and no accessory chromosome is present; but the spermatozoa nevertheless consist of two groups, equal in number, which differ in respect to one of the chromosomes, which may conveniently be called the "idiochromosome."

2. In all of the forms named, excepting *Nezara*, half the spermatozoa receive a larger, and half a smaller, idiochromosome. In *Nezara* the idiochromosomes are of equal size, but agree in behavior with the unequal forms.

3. In all of the forms the idiochromosomes remain separate and univalent in the first maturation-division, while the other chromosomes are bivalent; this division accordingly shows one more than half the spermatogonial number of chromosomes. They divide separately in the first mitosis, but at the close of this division their products conjugate to form a dyad, which in all the forms save *Nezara* is asymmetrical. The number of separate

<sup>1</sup>The discovery, referred to in a preceding foot-note, that the spermatogonial number in *Anasa* is 21 instead of 22, again goes far to set aside the difficulties here urged. Since this paper was sent to press I have also learned that Dr. N. M. Stevens (by whose kind permission I am able to refer to her results) has independently discovered in a beetle, *Tenebrio*, a pair of unequal chromosomes that are somewhat similar to the idiochromosomes in Hemiptera and undergo a corresponding distribution to the spermatozoa. She was able to determine, further, the significant fact that the small chromosome is present in the somatic cells of the male only, while in those of the female it is represented by a larger chromosome. These very interesting discoveries, now in course of publication, afford, I think, a strong support to the suggestion made above; and when considered in connection with the comparison I have drawn between the idiochromosomes and the accessory show that McClung's hypothesis may, in the end, prove to be well founded.

chromatin elements is thus reduced to one half the spermatogonial number. In the second maturation-division the asymmetrical dyad separates into its two unequal constituents, the larger one passing to one pole and the smaller one to the other pole of the spindle, while the other dyads divide equally.

4. In all the forms excepting *Nezara* the spermatogonia possess but one microchromosome (the small idiochromosome), while in *Nezara* two equal microchromosomes are present as in forms like *Anasa* which possess an accessory chromosome.

5. In the primary synapsis the idiochromosomes may unite to form a bivalent body or may remain separate. In the former case the bivalent body condenses to form a single chromosome-nucleolus that persists throughout the whole growth-period, but again separates into its univalent constituents before the first mitosis (directly proved in *Brochymena*, inferred in the other forms). If the idiochromosomes fail to unite in the primary synapsis, they remain separate through the growth-period in the form of chromosome-nucleoli. In either case the idiochromosomes divide separately in the first mitosis.

6. In *Lygæus* the large idiochromosome has in the synaptic and early post-synaptic periods the form of a long longitudinally split thread which afterward condenses into a hollow spheroidal chromosome-nucleolus.

Zoölogical Laboratory, Columbia University,  
May 5th, 1905.

#### WORKS CITED.

- BONNEVIE, K., '05.—Das Verhalten des Chromatins in den Keimzellen enteroxenos östergreni. *Anat. anz.*, xxvi, 13, 14, 15.
- GROSS, J., '04.—Die Spermatogenese von *Syromastes marginatus*; *Zool. Jahrb.*, Anat. u. Ontog., xx, 3.
- MONTGOMERY, T. H., '98.—The Spermatogenesis in *Pentatoma*, etc. *Zool. Jahrb.*, Anat. u. Ontog., xii.
- '01, 1.—A Study of the Chromosomes of the Germ-cells of Metazoa. *Trans. Amer. Phil. Soc.*, xx.
- '01, 2.—Further Studies on the Chromosomes of the Hemiptera heteroptera. *Proc. Acad. Nat. Sci., Phil.*, March, 1901.
- '04.—Some Observations and Considerations upon the Maturation Phenomena of the Germ-cells. *Biol. Bull.*, vi, 3, Feb.

- PAULMIER, F. C., '99.—The Spermatogenesis of *Anasa tristis*. Jour. Morph., xv, supplement.
- STRASBURGER, E., '04.—Ueber Reduktionsteilung. Sitzber. Kön. Preuss. Akad. Wiss., xviii, 24 März, 1904.
- SUTTON, W. S., '02.—On the Morphology of the Chromosome Group in *Brachystola magna*. Biol. Bull., iv, 1.
- '03.—The Chromosomes in Heredity. Biol. Bull., iv, 5.
- WILSON, E. B., '05.—Observations on the Chromosomes in Hemiptera. Rept. N. Y. Academy of Sciences, May 8th, 1905; Science, xxi, 548, June 30.





THE MOVEMENTS OF THE SWIMMING-PLATES IN  
CTENOPHORES, WITH REFERENCE TO THE  
THEORIES OF CILIARY METACHRONISM.

BY

G. H. PARKER.

WITH 2 FIGURES.

I. INTRODUCTION.

Since the publication in 1880 of Chun's elaborate monograph on the ctenophores, it has been generally admitted, contrary to the opinion of many of the older investigators, that the swimming-plates of these animals are their principal organs of locomotion. Moreover, the ciliary nature of these organs may now be regarded as well established, and their relatively enormous size has already made them favored objects with investigators of ciliary phenomena. As is well known, these swimming-plates are arranged in rows and the members of each row, like ordinary cilia, beat metachronally, not synchronally. The explanation of this peculiarity has called forth two somewhat opposing views. According to the first of these, which has been developed chiefly by Engelmann ('68, p. 475; '79, p. 388), it is maintained that one element beats immediately after its next neighbor in a given order because of a nerve-like impulse that is supposed to pass from cell to cell and thus to bring into action in regular sequence the overlying elements. This may be called the neuroid theory of ciliary action. According to the second view, advanced in the main by Verworn ('90, p. 175), the cause of metachronal action is not to be sought for in the cell-body proper, but rather in the mechanical effect of one cilium on another, in that the action of one cilium mechanically stimulates the next one to action. This may be called the mechanical theory of ciliary action. Because of the minute size of ordinary cilia, experimental tests of these two theories are not easily carried out; hence the anatomical conditions presented in ctenophores are of unusual importance. It is the principal object

of this paper to discuss the cause of metachronism in ciliary action as exemplified in the swimming-plates of these animals.

The material upon which I worked consisted almost entirely of the common summer ctenophore of the New England coast, *Mnemiopsis leidyi* A. Agassiz, though I also made some observations on the winter species *Pleurobrachia rhododactyla* L. Agassiz. The work was done for the most part during the last few summers at the Wood's Hole Laboratory of the United States Bureau of Fisheries, to the officers of which I am under obligations for many kindnesses shown me.

## II. OBSERVATIONS.

### *Anatomical.*

*Mnemiopsis leidyi* is a lobate ctenophore measuring often as

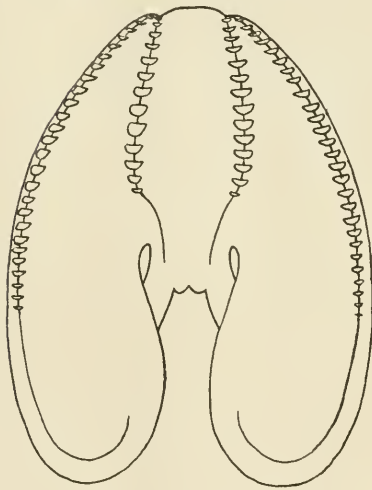

FIG. 1.

Side view of *Mnemiopsis leidyi*. The sagittal plane corresponds to that of the paper and the aboral pole is uppermost. Two short sub-transverse rows of swimming plates and two long subsagittal ones are seen converging toward the aboral pole. The subsagittal rows extend as vibratile lines far over the surface of the lobes.

much as seven or eight centimetres in length. Its external form is shown in Fig. 1, which is a view of the animal so placed that its sagittal plane corresponds to the plane of the paper. The mouth is directed downward and the two large lobes that characterize this group of ctenophores are seen at the right and left of it. The aboral pole is pointed upward and four of the eight rows of swimming-plates are shown converging toward it. Their relation to the sense body at the aboral pole can be seen clearly in Fig. 2, where it will be observed that from the most aboral plate of each row a narrow band extends to the sense body. These bands, before they reach the sense body, unite in pairs and enter that organ as

four bands. As will be seen by comparing Figs. 1 and 2, the rows of swimming-plates are either long or short and the pairs

formed by the unions into the bands consist always of a long row combined with a short one. Since the long rows lie near the sagittal plane and the short ones near the transverse, they have been called, respectively, subsagittal and subtransverse. The combination of a long subsagittal row with a short subtransverse one to form a pair has long been known to be one of the structural characteristics of the lobate ctenophores, and, as will be shown later, this feature is not without its physiological significance. Each such pair, as can be seen in Fig. 2, is restricted to a quadrant of the animal's body.

The number of swimming-plates in the subsagittal and the subtransverse rows varies more or less with the size of the animals. Thus in a small specimen eight millimeters long the subsagittal rows contained each about 19 plates, the subtransverse ones about 13; while in a large individual sixty millimeters long, there were about 73 plates in each subsagittal row and about 39 in the subtransverse ones. In the specimen from which Figs. 1 and 2 were drawn, there were about 29 plates in each subsagittal row and about 17 in each subtransverse one.

In *Mnemiopsis* the bands that lead from the sense body to the swimming-plates are ciliated, as in other ctenophores, and, as Samassa ('92, p. 229) has shown for other lobate forms, a band of cilia connects plate with plate.

In this species, however, the spaces between the plates seem to be much more sparsely provided with cilia than in other lobate ctenophores, if, in fact, cilia are not sometimes entirely absent from these regions.

The second species upon which I worked, *Pleurobrachia rhododactyla*, was of simpler structure than *Mnemiopsis*. It belongs to the Cydippidæ and has the typical form of an oblong spheroid. Its eight rows of swimming-plates are of about equal length and can be readily distinguished as subsagittal or subtransverse only by their relations to other parts in the animal's

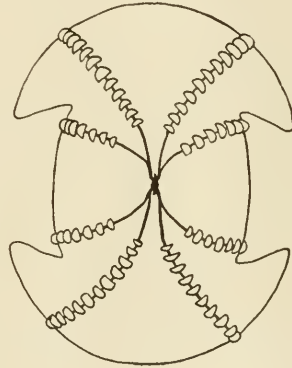

FIG. 2.

Aboral view of *Mnemiopsis leidyi*. The four subsagittal rows of swimming-plates, two from each lobe, and the four subtransverse ones converge on the sense body at the aboral pole.

body. In a specimen of average length, about sixteen millimetres, there were approximately 40 plates in each row.

*Physiological.*

The resting position of the swimming-plates in both *Mnemiopsis* and *Pleurobrachia* is one in which the individual plate is turned close to the body of the animal and with its tip directed orally. In action the plate makes a vigorous stroke aborally and then returns to its resting position. In consequence of such movements carried out more or less simultaneously by certain plates in each row, the animal's body is moved through the water with the mouth forward. The plates in any one row strike one after another beginning at the aboral end, *i. e.*, to use the term proposed by Verworn ('90, p. 152), they beat metachronally. Ordinarily the first plate to strike is the most aboral one and the others follow in sequence giving rise, by the order of their beat, to a wave-like appearance which progresses, of course, in an oral direction.

Chun ('80, p. 172) has shown that when in a normal animal a wave starts over one row, a like wave also starts over the other row of the same quadrant, *i. e.*, the two rows of any quadrant act in unison. This relation was observed by Verworn ('91, p. 456) in all the ctenophores that he studied, and it is certainly an invariable occurrence in *Mnemiopsis*, but not in *Pleurobrachia*. In *Pleurobrachia*, though the rows of plates on the same quadrant are often seen to beat in unison, they also frequently beat independently. That their beating in unison is not a mere matter of accident is seen from the fact that, whereas rows on the same quadrant often beat in unison, adjacent ones belonging to different quadrants do not beat in this manner. There can be no question, I believe, that the rule laid down by Chun, to the effect that rows on the same quadrant always beat in unison, has its exceptions, for in *Pleurobrachia* the two rows of any quadrant may beat independently. As might be expected from the researches of Chun ('80, p. 172), the removal of the sense body from *Mnemiopsis* or from *Pleurobrachia* is invariably followed by a complete loss of the partial or perfect unison of action between rows of plates.

Since there is an agreement in the metachronism of the two rows of plates on any quadrant in *Mnemiopsis*, there should

be a synchronism in the action of the corresponding plates in these two rows, and such proves to be the case. This condition is very noticeable when at the beginning of a series of swimming-plate movements, the waves run at varying rates, for when a wave passes rapidly or slowly over one row, it passes at the same rate over the other row of the same quadrant. Similar conditions were observed in *Pleurobrachia* when its swimming-plates were acting in unison.

The reversed action of the swimming-plates in ctenophores has been stated to occur by numerous observers, but the expression reversed action in this connection is undoubtedly somewhat ambiguous. In the so-called reversal of cilia and other like organs at least two kinds of reversal are possible: a reversal of the propagation wave, "Reizwelle" of Engelmann, and a reversal of the effective stroke of the cilia (Parker, '05, p. 9). In the first instance the question turns on the sequence in which the cilia beat; thus in the normal action of a series of cilia, element *a* may beat first and *z* last, the propagation wave passing from *a* to *z*, while in reversed action *z* would beat first and *a* last, the wave passing in the reverse direction. In the second instance only the effective stroke of the cilium is concerned; this may be normally toward *z* or reversed toward *a* irrespective of the sequence in which the cilia of the series act.

In ctenophores a reversal of the direction of the propagation wave has often been observed. This was early noticed on fragments of *Beroë* by Eimer ('80, p. 226), an observation confirmed on this and other species by Chun ('80, p. 182) and by Verworn ('90, p. 167; '91, p. 459), though the latter is misquoted in this respect by Pütter ('03, p. 35). Reversal of the propagation wave occurs occasionally in *Pleurobrachia*. When a rapid wave from the aboral end of the animal reaches the oral limit of a row of plates, it may be reflected aborally over the row again, but it seldom retraces its course for more than one-third the whole length of the row. As Verworn ('90, p. 167; '91, p. 440) observed, these reversed waves can often be induced by stimulating mechanically the oral end of a row of swimming-plates.

In *Mnemiopsis* I have never observed unquestionably reversed waves, nor have I been able to induce them by special stimulation. Some slight evidence of reversal has been seen when a relatively slowly moving wave near the oral end of its course is overtaken

by a more rapid one. This is seen to sweep over the slower wave and, as it does so, what seems to be a reversed wave starts from the point of collision and runs aborally over not more than six or eight plates at most. This short wave is the only evidence of reversal that I have found in *Mnemiopsis*; it is my belief that this reversal of the swimming-plate action, so common in many ctenophores, is almost entirely absent from this species.

According to previous investigators, ctenophores can reverse the effective stroke of the swimming-plates as well as change the direction of the propagation wave. Under ordinary conditions, the effective stroke carries the animal with the oral end forward; when this is reversed, the animal moves with the aboral end ahead. Chun ('80, p. 181) mentions that this reversed form of locomotion is a regular though rare occurrence with all ctenophores, especially when by normal locomotion their oral ends collide with some fixed body. Verworn ('91, p. 432) states that he has on rare occasions observed this reversed swimming in *Eucharis* and *Callianira*, but not in other species of ctenophores. I have never seen any evidence of the reversal of the effective stroke in either *Pleurobrachia* or *Mnemiopsis* and I am inclined to believe that Chun's statement that the effective stroke can be reversed in all ctenophores, may be a mistake based upon a confusion of this form of reversal with the reversal of the propagation wave. In *Pleurobrachia* it can be easily shown that when the propagation wave reverses from an oral to an aboral direction the swimming-plates continue their effective stroke in an aboral direction as before.

When a row of swimming-plates in *Pleurobrachia* or *Mnemiopsis* is cut through so as to divide it into oral and aboral portions, the plates in both parts cease to move for a short time and when they resume their activity, the two parts are found to beat differently, *i. e.*, their propagation waves are found to be independent. In this respect the American species agrees with the European forms experimented upon by Eimer ('80, p. 227), Verworn ('90 p. 167), and others. If a row in *Mnemiopsis* is cut with care, the aboral part almost immediately begins to beat metachronally with reference to its fellow of the same quadrant, and the oral part reestablishes independent movements in a few minutes or even seconds. In the quickness of recovery of the oral part *Mnemiopsis* is in strong contrast with *Beroë* and *Eucharis*, in which, accord-

ing to Krukenberg ('80, p. 2) and Verworn ('90, p. 156), the activity of the oral part may not return for an hour or so after the row is cut. The waves in the oral part of *Mnemiopsis* always proceed from near the cut end of the row orally; the most aboral plate to show motion, however, is not the one next the wound but usually the third or fourth from it. The oral portion will thus move its swimming-plates for hours without relation to the movements of the aboral part. I have never seen any evidence of the reestablishment of harmony in the two parts of a severed row such as has been described by Eimer ('80, p. 229) and Verworn ('90, p. 167; '91, p. 463). When a swimming-plate band is cut through, not where there are swimming-plates but between the most aboral plate and the sense body (compare Fig. 2), the whole row in its movements becomes independent of the sense body and if the sense body is destroyed, the coördination of the four pairs of rows entirely disappears, as has already been shown by Verworn ('91, pp. 457-459) and others for several European species.

When a *Mnemiopsis* is cut in two transversely, the parts of rows on the aboral portion retain their coördination as in a normal animal; those on the oral part, as might be expected, lose all signs of such relations. It is clear from this and the preceding experiments that the coördinating influences proceed from the aboral pole, and, when this is lost, coördination disappears. In this respect my observations confirm those of Krukenberg ('80, p. 2) on *Beroë* and are opposed to those of Eimer ('80, p. 231), who stated that the oral half of *Beroë* is indistinguishable in the movements of its plates from a whole animal.

When a *Mnemiopsis* is shaken in sea-water, it can be broken easily into fragments and the plates attached to these pieces will continue to beat rhythmically and metachronally for from one to two days. As Verworn ('90, p. 157) has shown for *Cestus*, so also in *Mnemiopsis*, even a single plate with a small basal piece of protoplasm will beat rhythmically for a long time. This condition led Verworn to believe that each plate possessed a certain degree of autonomy, which was seen in the continued activity of the isolated plates and must be imagined to be counteracted by some influence when the plate as a member of a row was quiescent. But in my opinion the swimming-plate, when it beats, does so because it is stimulated, and its quiescence is evidence of the absence of appropriate stimuli. When it beats normally on

a whole animal, it does so in response to a wave of stimulation from the aboral pole, the cessation of which is followed by the cessation of the movement in the plate. When one plate with a small amount of protoplasm attached continues to beat, as it often will for hours, it does so because the fragmentary condition of its base exposes this part to continual stimulation. I see no reason to assume that the plates possess an autonomy that is inhibited much of the time by the animal.

A fragment of a swimming-plate of *Mnemiopsis* made by splitting the plate lengthwise will continue to beat if a small basal mass of protoplasm is still attached to it. Whole swimming-plates or fragments of plates cease to beat when the base is trimmed off to such an extent that only the swimming-plate proper is left. In this respect the plates of *Mnemiopsis* resemble those of the ctenophores on which Verworn ('90, pp. 158, 161) experimented. This failure of the isolated plates to vibrate has generally been attributed to the loss of a stimulus normally received from the basal protoplasm, but Pütter ('03, p. 42) has suggested that it may be due to the rapid death of the plates after isolation from the living substance of the animal. That this is not so in *Mnemiopsis* is seen from the fact that a fragment of a plate cut off from its basal protoplasm and kept in sea water half an hour trembles and curves when a little picric acid is applied to it just as the living plates do on a whole animal when this reagent is poured on them. I therefore believe that the quiescence of isolated plates is due to the absence of a stimulus to contraction and not to early death.

It is evident from what has preceded that the rows of swimming-plates of ctenophores ordinarily beat in pairs corresponding to the quadrants of the animal's body and that the plates of any row beat metachronally beginning ordinarily at the aboral end. As Chun ('80, p. 172) long ago pointed out, that which regulates their beat proceeds usually from the region of the aboral pole and here four centers must be assumed, one for each quadrant of the animal's body. It is also evident that the regulating influence in its passage from the aboral pole is strictly limited to the bands leading from the sense body to the rows of plates, and to the rows of plates themselves, and that, though the waves usually start from the aboral end and progress toward the oral one, they may in some species reverse and run some distance aborally. All these



facts are explainable on either the theory of neuroid transmission as advocated by Engelmann, or on that of mechanical transmission as put forward by Verworn; for on the former assumption the band of epithelium leading from the sense body to the oral end of a row of swimming-plates may serve as a transmitting tract, and on the latter the ciliated bands leading from the sense body to the rows of plates may serve to transmit the mechanical disturbance from the center to the plates. I propose now to turn to certain observations that are, in my opinion, inconsistent with one or other of these theories.

Since in accordance with the idea of mechanical transmission the mechanical activity of the vibratile elements is a necessary accompaniment of transmission, it follows that any means of bringing this activity to a standstill ought to check transmission. It might be supposed that the cutting off of one or more plates would produce such an effect. When this is done in *Cestus*, according to Verworn ('90, p. 173), and in *Mnemiopsis*, according to my own observations, the waves still pass regularly over the whole row of plates and are not interrupted by the interval from which the plates have been removed. Since, however, the spaces between the plates in *Cestus*, as well as in the lobate ctenophores, have been shown by Samassa ('92, p. 229) to be ciliated, it might be assumed that these cilia in their vibrations transmit the mechanical disturbance over the whole row. The assumption that in the absence of plates the cilia may transmit the disturbance is, however, in my opinion improbable, for the space made by the removal of a plate is so considerable in comparison with the length of the cilia that, unless we assume as Verworn ('90, p. 173) does that the whole base of the plate is surrounded by cilia, I see no way by which the mechanical disturbance made by the cilia on one side of the root of the plate could influence those on the other side and thus effect transmission. As I have never seen in *Mnemiopsis* any reason to believe that the plates are surrounded at their bases by cilia, I do not believe that transmission can be accounted for in the present experiments by the mechanical theory, even admitting the presence of cilia between the plates.

A modification of the experiment just described has been employed by Verworn ('90, p. 171) with the view of testing further the nature of transmission. This experiment consisted in restraining a plate from beating instead of cutting it off and then ascer-

taining whether waves passed beyond it. When a plate in *Beroë* is turned aborally by a lancet point, waves from the aboral end fail to pass this plate. If only the tip of the plate is held and the base is allowed to move, the wave passes onward to the oral portion of the row. These observations led Verworn ('90, p. 171) to conclude that the mechanical vibrations of the plates were necessary for transmission, and he drew this conclusion notwithstanding the fact that in *Cestus* he ('90, p. 172) found that the holding or even the pulling out of a plate did not interfere with transmission. Verworn confessed to have been astonished at the conditions found in this species, but, as already stated, he believed that they might be explained on the assumption that the base of each plate is more or less surrounded by cilia which after the removal of the plate continue to transmit mechanically. Unfortunately I have been unable to try the experiment of restraining plates in *Mnemiopsis*, for the rows of plates in this species, like those in *Beroë*, as pointed out by Krukenberg ('80, p. 10), are so sensitive to mechanical stimulation that the moment they are touched they are drawn down into the animal's body to such an extent as to make experiments of this kind very unsatisfactory, if not impossible.

Although the great sensitiveness of the rows of plates in *Mnemiopsis* prevented me from trying the experiment of holding plates individually, it afforded a very natural means of checking their action. As Verworn ('90, p. 170) has shown, when the middle of a row of plates is touched, the row in that region becomes depressed and the edges of the depression fold over and cover the plates. Thus in *Mnemiopsis* half a dozen plates may become so much restrained that they will not show the least motion and yet waves that arrive at the aboral entrance to this depression emerge from its oral end with the greatest regularity. This may happen while the covered region is under close inspection through a lens and gives not the least sign of plate or ciliary movement. I am, therefore, forced to conclude, that, contrary to the statement made by Verworn ('90, p. 170), such restrained tracts transmit with perfect regularity even in the absence of observable ciliary and plate motion.

Kraft ('90, p. 223) in his study of the ciliated epithelia of vertebrates, showed that, though low temperature may bring cilia to a standstill, it does not greatly check the transmitting power of the tissue. It ought, therefore, to be possible to check the action of

plates in a ctenophore by cold and yet leave the transmitting power of the row unimpaired. To test this proposition, I passed a small curved metal tube through the substance of a *Mnemiopsis* directly under one of its rows of swimming-plates and at right angles to the direction of the row. The animal was anchored by being pinned in a small aquarium of sea water whose temperature was  $21^{\circ}$  C. Normal waves of action were seen to course over the row of swimming-plates under which the metal tube had been placed. I now passed through the tube water of a temperature between  $4^{\circ}$  and  $5^{\circ}$  C. A steady flow was kept up to insure as complete a chilling as possible of that portion of the row under which the tube went. The chilled plates soon ceased to move and the waves appeared to jump from the aboral side from which they approached the chilled region to the oral one beyond it. Sometimes half a dozen waves in rapid succession appeared thus to jump this chilled region. But the best evidence was obtained when the waves ran at considerable intervals, at which times the correspondence between the parts of the wave in front of and behind the chilled region was most striking. To be certain that there was no movement of cilia or plates in the chilled region, a small amount of powdered carmine in sea water was placed on the plates of that portion. The carmine remained motionless while wave after wave ran over the aboral and the oral parts of the row. At the close of the experiment the chilled region was allowed to regain its normal temperature, whereupon its plates became vibratile again and the waves passed without interruption. This experiment was repeated on six different individuals and with constant results. In one instance the temperature of the water used for chilling the tissue was  $8.5^{\circ}$  C. and under this condition the cessation of movement was only partial, but in all other experiments the temperature was kept at  $5^{\circ}$  C. or lower with the result that complete cessation of movement invariably followed. Hence it is fair to conclude that in *Mnemiopsis* a temperature of  $5^{\circ}$  C. or less will check the movement of the swimming-plates without essentially altering the transmitting power of the row.

In handling ctenophores in the experiments last described, I noticed that when the row of plates under which the metal tube passed was subjected to a little local stretching by the awkward manipulation of the tube, the plates often ceased to vibrate in the stretched region. On repeating this operation I found that as a

rule the slight stretching of a region would bring the plates of that part to a standstill, though it did not interfere seriously with transmission. But it must be noted that in such an operation much care must be used not to overstrain the tissue, for otherwise a permanent cessation of action will follow. Avoiding this difficulty, however, mechanical strain, like low temperature, may be made to check motion without interfering with transmission.

### III. THEORETIC CONSIDERATIONS.

The results of the experiments just described, in which the swimming-plates of ctenophores were removed or restrained, or the row chilled or stretched locally, afford good grounds for denying to the mechanical theory any essential part in the explanation of ciliary metachronism. If ordinary transmission is really dependent upon the mechanical action of one element on the next, it is inconceivable how such a process can be accomplished when these elements for any reason cease to move. That transmission does take place after the swimming-plates have been brought to a standstill by physical restraint, cold, etc., is unquestionable. Verworn ('90, p. 172) admitted surprise when he found that in *Cestus* transmission occurred even after the removal of a plate and he was led to assume a continuous band of cilia to account for this condition. In *Mnemiopsis* no such band is present and yet transmission takes place even after the removal of a plate.

The failure of a wave to pass when the plates in *Beroë* are restrained from moving is not, as Verworn believed, a satisfactory test of the nature of transmission, for, notwithstanding the care used in restraining the plate, the operation may influence the deeper parts of the tissue and thus check transmission as well as plate movement. The fact that transmission does occur in *Mnemiopsis* when the plates are restrained, shows how treacherous such negative evidence is. These facts, together with the evidence from chilled and stretched rows, show, I believe, that the mechanical theory is not a necessary part of the explanation of ciliary metachronism.

Although the mechanical theory may not be the correct explanation of transmission, its rejection does not imply a rejection of the idea that the plates are open to mechanical stimulation. Everyone who has worked with ctenophores knows how sensitive the

plates are in this respect. The slightest touch will often cause them to vibrate and will even give rise to a wave which, beginning with the plate stimulated, runs orally over the row. This condition is undoubtedly suggestive of such a view as that advanced by Verworn; his ('90, p. 168) ingenious experiment of attaching plate to plate by cotton filaments and thus obtaining a form of mechanical transmission shows how this idea may find application. When, however, it is remembered that in rest the plates point orally, that the propagation wave ordinarily proceeds from the aboral end of the row, and that the effective stroke of the plate is made in the aboral direction, it is clear that each plate as it goes into action does not strike toward the next plate to act but away from it and hence in a direction unfavorable for mechanical stimulation. When the propagation wave is reversed, as happens in *Pleurobrachia* and probably in many other ctenophores, the action of the plates is such that an oral one may well stimulate mechanically the next in turn, and, while I believe that the normal wave depends for its propagation upon a neuroid transmission, I am inclined to the opinion that the reversed waves may depend largely on mechanical transmission. As is well known, these reversed waves seldom extend far and are always insignificant as compared with the normal ones. Hence I do not believe that mechanical stimulation plays any really important part in transmitting the normal wave.

Direct stimulation seems to be a possible means of transmission over a cut in a row of plates. Since both Eimer ('80, p. 229) and Verworn ('90, p. 167) have recorded the occurrence of this form of transmission in European species, it might be looked for in other forms, though I have been unable to find any evidence of it in *Mnemiopsis* or *Pleurobrachia*. However, I see no reason why the vibration of a plate on the aboral side of a cut may not stimulate to action a plate on the oral side of the same cut provided the two plates are brought close enough together. The subject is worthy of further investigation.

Most of the observations that have been brought forward against the mechanical theory might now be urged in favor of the neuroid theory, for transmission without ciliary or plate motion is what is implied by this view. The idea that the movement of the swimming-plates is controlled by nerves was held by some of the older investigators such as Eimer ('73, p. 45) and Krukenberg

('80, p. 5), though on insufficient grounds, for no one has ever demonstrated that nerves are connected with these plates. Engelmann ('87, p. 442) has used the expression "innervated" in reference to the rows of swimming-plates, but it is perfectly evident from other statements in his account (p. 440) that this term is used in a physiological sense and not in an anatomical one, and that he consistently adheres to his original idea ('79, p. 395) of epithelial transmission. Chun ('80, p. 173) made perhaps the best brief statement of the mechanism of transmission in ctenophores when he declared that the rows of epithelial cells served as nerves. It is in my opinion an open question whether in any instance cilia are really controlled by nerves. Such a control is denied by Verworn ('95, p. 251), though Pütter ('03, p. 98) in his recent survey of the whole subject of ciliary activity states that in the larvæ of certain annelids such control occurs. It seems to me that Pütter's grounds are insufficient for such a conclusion; but, however this question may stand for annelids, in the ctenophores not the least histological evidence has ever been advanced to show that their rows of plates are accompanied by nerves. Samassa ('92, p. 226), who has studied this matter with care, denies that ctenophores have any nervous system properly so called and points (p. 230) to the epithelial bands in *Beroë* as the transmitting organs. There thus seems to be good reason for believing that the epithelial cells on the rows of swimming-plates in ctenophores transmit impulses that control the metachronism of these plates; in other words the neuroid theory, contrary to the statement made by Verworn ('90, p. 175), is tenable. Such a conclusion is entirely consistent with the results of Gruetzner ('82) and of Kraft ('90) in their experiments on transmission in the ciliated epithelia of the higher animals, for both investigators found it necessary to assume a deep-seated cellular transmission to explain the spread of ciliary disturbances in active and in quiescent fields of cilia.

Although the results of my experiments make me confident that the metachronism of the swimming-plates of ctenophores is due to neuroid transmission, I do not believe that the facts warrant the extreme position taken by Engelmann ('87, p. 440) that no form of mechanical transmission obtains. It seems to me much more likely that, as Chun ('80, p. 174) has declared, mechanical action is a subordinate though real factor in transmission. In my

opinion, this factor would never of itself result in giving rise even to a single full wave, though it might, if vigorously started, carry a wave over a small number of plates. Its influence at most would be only of a subordinate character. Chun's view that both neuroid and mechanical factors take part in transmission has been adopted by Pütter ('03, p. 98).

While mechanical transmission may be of only subordinate importance, mechanical stimulation must be regarded as of no small significance. It has already been pointed out that a plate, if mechanically stimulated, may become the point of origin of a wave which will be transmitted over the row of plates in all respects normally. Hence mechanical stimulation will not only bring a plate into action but will induce the formation of a normal neuroid propagation wave.

If the ciliated epithelia of the higher animals and such specialized structures as the swimming-plates of the ctenophores are controlled by impulses that are passed in a definite direction and within circumscribed limits from cell to cell, it seems highly probable that many of the coördinated responses of the lower metazoans and of the early larval stages of the higher forms may depend upon this form of mechanism rather than on any kind of true nervous organization. Thus it may well be that the slow but uniform responses of sponges to local stimulation may be due to neuroid transmission through their epithelial layers and not through true nervous tissue, which, as is well known, has been sought for in vain in these animals. The exact orientation to light of larval sea urchins at the blastula or gastrula stage involves a certain coördinated beat of the cilia which, in the absence of nervous elements, may well be due to neuroid transmission. Thus animals in such early stages of growth may carry out by means of their epithelia reactions which in later stages would be performed by a true nervous mechanism. Conditions of this kind lead me to believe that before primitive metazoans possessed any nervous organs whatever, they probably had in their epithelia organs which exhibited the most fundamental property of nervous tissue, namely, a capacity to transmit in a prescribed direction impulses to motion. From epithelia of this kind sense organs and central nervous organs were probably evolved, and yet this evolution did not bring about the entire suppression of these primitive pre-nervous mechanisms; for the ciliated epithelia of the highest

animals, as well as the swimming-plates of the ctenophores, still possess the power of neuroid transmission.

#### IV. SUMMARY.

1. In *Mnemiopsis* and *Pleurobrachia* the swimming-plates normally beat metachronally beginning at the aboral ends of the rows.

2. In *Mnemiopsis* the two rows of plates belonging to the same quadrant of the animal's body beat in unison. In *Pleurobrachia* this is also often true, but all eight rows in this ctenophore may beat independently.

3. The propagation wave ("Reizwelle" of Engelmann) shows scarcely any evidence of reversal in *Mnemiopsis*, but often reverses in *Pleurobrachia*.

4. Reversal of the effective stroke of the plates was never observed in *Mnemiopsis* or in *Pleurobrachia*.

5. On cutting a row of plates in *Mnemiopsis* transversely, the oral part quickly recovers and begins beating, but not in unison with any other part; the aboral part also recovers soon and beats in unison with the other row of its quadrant.

6. A single isolated plate will beat if it retains a small amount of basal protoplasm.

7. Plates without basal protoplasm will not beat, though they are not dead.

8. Loss of a plate in a row does not prevent the passage of a wave even in *Mnemiopsis* where the cilia on the rows do not always form continuous bands.

9. When the plates on part of a row in *Mnemiopsis* are restrained from moving, an impulse to plate movement may still be transmitted.

10. Cooling a part of a row with water at 5° C. will bring the movement of the plates to a standstill, but not interrupt transmission.

11. Stretching part of a row will cause local cessation of movement, but will not interrupt transmission.

12. The metachronism of the plates in ctenophores cannot be explained as a result of the mechanical influence of one plate on its neighbor, but the facts observed necessitate the assumption of a deep-seated transmission from cell to cell, nerve-like in character.



13. This neuroid transmission is probably supplemented by mechanical transmission, which of itself is insufficient to carry forward a normal wave.

14. Phylogenetically an epithelium with neuroid transmission probably preceded true nervous structures and such an epithelium is in all likelihood the only means of transmission in many animals at their earliest larval stages (blastulæ, gastrulæ, etc.) and in such primitive forms as sponges.

BIBLIOGRAPHY.

- CHUN, C., '80.—Die Ctenophoren des Golfes von Neapel. Fauna und Flora des Golfes von Neapel. I. Monographie. xviii, 313 pp., 18 Taf.
- EIMER, T., '73.—Ueber Beroë ovatus. Zoologische Studien auf Capri. I. 92 pp., 9 Taf.
- '80.—Versuche über künstliche Theilbarkeit von Beroë ovatus. Arch. f. mikr. Anat., Bd. 17, pp. 213-240.
- ENGELMANN, T. W., '68.—Ueber die Flimmerbewegung. Jena Zeitschr., Bd. 4, pp. 321-478.
- '79.—Physiologie der Protoplasma- und Flimmerbewegung. Hermann, L., Handbuch der Physiologie, Bd. 1, Theil 1, pp. 343-408.
- '87.—Ueber die Function der Otolithen. Zool. Anz., Jahrg. 10, No. 258, pp. 439-444.
- GRUETZNER, P., '82.—Zur Physiologie des Flimmerepithels. Physiol. Studien, pp. 1-32.
- KRAFT, H., '90.—Zur Physiologie des Flimmerepithels bei Wirbelthieren. Arch. f. ges. Physiol., Bd. 47, Hefte 4, 5, pp. 196-235.
- KRUKENBERG, C. F. W., '80.—Der Schlag der Schwingplättchen bei Beroë ovatus. Vergleichend-physiologische Studien zu Tunis, Mentone und Palermo, Abt. 3, pp. 1-23.
- PARKER, G. H., '05.—The Reversal of Ciliary Movements in Metazoans. Amer. Jour. Physiol., vol. 12, No. 1, pp. 1-16.
- PÜTTER, A., '03.—Die Flimmerbewegung. Ergeb. Physiol., Jahrg. 2, Abt. 2, pp. 1-102.
- SAMASSA, P., '92.—Zur Histologie der Ctenophoren. Arch. f. mikr. Anat., Bd. 40, pp. 157-243, Taf. 8-12.
- VERWORN, M., '90.—Studien zur Physiologie der Flimmerbewegung. Arch. f. ges. Physiol., Bd. 48, Hefte 3, 4, pp. 149-180.
- '91.—Gleichgewicht und Otolithenorgan. Arch. f. ges. Physiol., Bd. 50, Hefte 9, 10, pp. 423-472.
- '95.—Allgemeine Physiologie. Jena, 8vo, xii +, 584 pp.



# ON A GENERAL THEORY OF ADAPTATION AND SELECTION.

BY

HENRY EDWARD CRAMPTON, PH.D.

It is the purpose of the present brief article to state in general and non-mathematical form some of the results of statistical and experimental studies, dealing with lepidoptera, that have been in progress for nearly six years, and in the second place to develop on the foundation of these results a generalized conception of natural selection and its actual basis during the segregation of the fit or adapted and the unfit or unadapted individuals of a species. I am led to offer this statement in this form and at this time because many months must elapse before the statistical results of recent studies may be put in final form for publication, though the more general conclusions to be drawn from them may be stated in simple terms; and it is my desire, furthermore, to present the theory so that it may bear the scrutiny of the numerous investigators now at work upon the problems of variation and selection, in order that its validity may be tested in connection with different kinds of biological material. In a word, this paper is an outline of a fuller discussion that must be deferred until the complete statistical results of my own investigations may be brought into relation with those of other investigators of the problem of natural selection and of its actual basis.

## I.

In 1899 a brief preliminary investigation was begun upon the pupæ of a saturnid moth, *Philosamia cynthia*, in order to ascertain whether there was a definite relation between the variability of various pupal structures and the elimination that took place after the larvæ spun their cocoons in the fall of the year and pupated. The same question was also examined with reference to the reduction in numbers that occurred when the pupæ emerged in

the following spring, when many individuals proved to be unable to form perfect moths, and thus offered a comparison with the pupæ that metamorphosed successfully and perfectly. The material possessed a peculiar interest for the reason that the pupa does not "use" many of its structures at all during its long period of quiescence but remains practically inactive until the time for emergence approaches. To state the results of this investigation in briefest form, it was found in many instances that the pupæ which died before metamorphosis were of somewhat different types and were more variable than the surviving individuals; and the same relation between elimination at the time of metamorphosis and structural variation appeared on the basis of a statistical examination of the two groups of pupæ distinguished at that time.<sup>1</sup>

Since 1900, the same species has been much more extensively examined to see if similar phenomena were exhibited in other years, and other forms of related moths have also been investigated—*i. e.*, *cecropia*, *promethea*, *ruber*, *zorilla*, etc. The results have been confirmatory, in that in every series where successful pupæ have been compared with unsuccessful pupæ some of the characters exhibit the stated relation between variation and elimination.

Nevertheless, the conclusion that this relation was a general and a final one did not appear to me to be justified, for there were many cases where the reverse was true, where, that is, the survivors were of the same type as the others but were *more* variable, or they were of the same type and variability. In addition, the characters that exhibited "selection," where it was indicated, were of such a nature that they could hardly have served the pupa either advantageously or disadvantageously. The pupa does not "use" its antenna, and yet the pupæ that succeeded in producing perfect moths often possessed antennæ that were certainly selectively different from those of the contrasted unsuccessful group. It was inferred, therefore, that selection was "indirect," and that the real basis for selection was not to be sought in the series of individual characters themselves but in the condition of correlation between and among these characters. The conclusion of the preliminary study reads as follows:

<sup>1</sup>See *Biometrika*, vol. iii.

“ . . . the test of fitness or unfitness has reference to the physiological and morphological co-ordination or correlation among the constituents of the whole organism, and . . . any relaxation in either series, in a formative sense or otherwise, results in an instability which may culminate in death, and which expresses itself in structural deviation as well as in a higher degree of variability.”

It is implied in the foregoing that a distinction may be made between formative correlation and functional correlation. In a later instalment<sup>1</sup> the subject is discussed at length, and it is contended that the condition of correlation exhibited by the structures of the pupa is dependent upon the correlation of the formative factors or agencies which control the manufacture of the pupa by the larva, while the immediate functional elements are concerned scarcely if at all. The case is therefore quite different from that of the moth, where indeed formative factors of the general condition of correlation must be operative, but where the physiological co-ordination of the imaginal structures has a large share in determining the “fitness” of the organism. But entirely aside from the relative values to be assigned to these two classes of factors, the point is that the separate “characters” do not serve directly as adaptive or unadaptive elements of the organism, but they do so only in so far as they exist in close or loose correlation with other structural and functional characteristics.

## II.

The truth of the conclusion stated was next put to the test of quantitative determination. The co-efficients of correlation were determined, according to the familiar methods, in the case of the characters that had been previously treated individually in their relation to elimination, and the co-efficients of correlation of the two groups were compared, *with positive results*. While it is true that the general condition of correlation, regarded as the basis for elimination, is only imperfectly indicated by the degree of correlation between any two characters and that the co-efficients of multiple correlation involving three or more characters would be more reliable as indices of this condition, yet if the principle be true

---

<sup>1</sup>Now in press, *Biometrika*.

the advantage in favor of the surviving or more successful group of pupæ should appear more clearly where the co-efficients of correlation are used than where the comparison with the eliminated group is based upon the types and variabilities of the individual characters concerned. Such is, indeed, the case. While the former group is not invariably the superior in correlation, there is a smaller proportion of negative cases than where the individual characters are taken singly; so that definite confirmation is found for the conclusion reached at first entirely by inference.

### III.

It now becomes the task to develop the principle of "the correlative basis for selection" so as to cover the wider range, over which, I believe, it extends. And I may state at the outset that statistical results have already been obtained proving in part that the wider range is indeed covered, though in the nature of the case, as will appear, complete mathematical demonstration is impossible.

So far, the general condition of correlation, which it is contended serves as the basis for elimination, has been regarded as determined by the whole series of internal or organismal characters taken together. We may next attempt to bring the series of environmental conditions or influences into the case by taking as an illustration the correlation between a single internal character as representing the whole series of internal characters and a single external character as a representative of that series. The first is "*length of pupal period*" in days, and the second is the "*time of the year.*" Neither of these varieties is simple, it is true. The time of emergence will depend upon a number of things, upon the time of pupation, upon the weight of the whole organism, which, it is found, is indeed correlated with the type character; while in the second place the time of emergence is dependent also upon the time of the year, as increase of temperature hastens metamorphosis. But the point is rather, that when a given series of pupæ is kept under natural conditions of temperature, their times of emergence, even when they are members of a single family, will form a curve of error, like that of structural character such as antenna length, weight, etc. Likewise, the time of the year reckoned as so many days from an arbitrary date such as January first, will form a

curve; and this external "character" too, is compound or at least representative of a series of external influences that affect lepidoptera, for not only will temperature conditions agree with calendar time, but food-supply and many other things will follow in a general way the temporal curve. It is clear, I think, that a certain degree of correlation between time of the year and metamorphosis will be adaptive, while a low degree will be unadaptive. Those individuals that mature too early will, even if they find mates, produce eggs and larvæ that will find poor food-supply, while those that emerge too late, supposing that they too find similar mates, will produce larvæ that will not have time to become full fed before cold weather will kill them and cut off their food-supply. Facts might be cited, showing still further that those that differ most from the average as regards the time of metamorphosis, vary also in unadaptive directions in internal characters, producing few eggs, possessing imperfect wings, and in other ways. It is needless to amplify the disadvantages that a lack of correlation with external influences or conditions would entail.

In brief, then, we find that the principle of correlative basis for selection involves not only the whole constitution of the organism itself, but the whole series of graded external influences as well, be these inorganic or organic, homogeneric or heterogeneric.

#### IV.

A few words are necessary with regard to the relations of the conception presented above. In the first place, it differs from the general theories hitherto brought forward in having a concrete basis in the results of statistical investigations of correlation and variation, and secondly, in that it places the series of external conditions on the same plane as the series of internal conditions, in their relation to the final welfare of the organism, regarding them also as varying according to the familiar laws of error. How far it may be justifiable to extend this principle over the external world, remains for future investigation; but it will be possible, as I believe, to utilize statistical methods in such investigations.

Selection is not regarded as in any way *originative* but only as *judicial*, so to speak. As the members of any species present themselves at the bar, "selection" decides the question of survival

or destruction on the basis of the condition of correlation that is exhibited. Adaptation receives a precise definition: it means a degree of correlation, capable of numerical determination; and the question as to the utility of any given character becomes subordinate to the question of the effectiveness of any given *combination* of unit-characters, working in a functional or formative complex.

Finally, to possess an evolutionary value, this conception must be taken in connection with the view that the heritable characters of an organism are congenitally determined. The heritable nature of fluctuations as contrasted with mutations, however, is not a matter that is necessarily brought into court.

Barnard College, Columbia University,  
June 10, 1905.



# EXPERIMENTAL STUDIES ON THE DEVELOPMENT OF THE EYE IN AMPHIBIA.

## II. ON THE CORNEA.

BY

WARREN HARMON LEWIS.

*Associate Professor of Anatomy, Johns Hopkins University.*

WITH 2 PLATES.

### INTRODUCTION.

With the introduction of the binocular dissecting microscope the possibilities of investigating the subject of correlative embryology have been greatly enhanced. With its aid, as I have already pointed out in my paper on the origin of the lens in *Rana palustris*, one can make with very delicate instruments exceedingly minute dissections of the living amphibian embryo, and by transplantation and extirpation of organs and tissues can gain an insight into the influences of intra-organic environment in development. Spemann's experiments on *Rana fusca* and my own on *Rana palustris* establish without doubt the correlative character of the origin of the lens in these two species and my unpublished work on *Rana sylvatica* and *Amblystoma punctatum* show that in these species likewise the lens is dependent for its origin on the influence exerted by the optic vesicle on the overlying ectoderm. The cornea is likewise a correlative product, but of a quite different nature from the lens as will appear in the following pages. While the lens is apparently dependent upon specific influences from the optic cup, the cornea or rather corneal changes of the ectoderm may be brought about by such different structures as the lens alone or of the optic cup alone. Spemann<sup>1</sup> concludes that the clearing of the corneal ectoderm is dependent in *Rana fusca* on the presence beneath the skin of the eye with its lens. In my own experiments on *Rana palustris*<sup>2</sup> it was noted that in

<sup>1</sup> Verhand. d. Anat. Gesel., 1901.

<sup>2</sup> Am. Jour. of Anat., vol. iii, Fig. 9, p. 512.

this species likewise corneal clearing of the ectoderm fails when the eye is wanting. In this paper it will be clearly shown, however, that corneal clearing of the ectoderm in *Amblystoma* will occur over a naked lens or over the optic cup without the lens, provided the lens or cup are close to the overlying ectoderm. If this be true for *Amblystoma* it probably holds also for other amphibia and consequently Spemann's conclusion for *Rana fusca* should be modified to this extent.

In a preliminary communication before the Association of American Anatomists, at Philadelphia, 1903,<sup>1</sup> concerning my experimental studies on the development of the eye in amphibia, the following conclusions were given for the cornea: "(1) The cornea fails to develop when the optic vesicle is entirely removed. (2) Over the regenerated eye with lens a cornea develops, normally, except for size, which is small to correspond to the small regenerated eye. (3) If the optic cup is torn out after the lens has separated from the skin, a small area of clear epithelium will develop immediately over the undisturbed lens. (4) Such clearing for the cornea will also develop over an optic cup, from which the lens has been extracted, but not in all cases."

These conclusions were based mainly upon experiments on *Amblystoma punctatum* and *Rana palustris*. More recent experiments on *Rana sylvatica* show that in this species also the cornea fails to develop when the eye is wanting. The present paper is concerned more especially with the conditions in *Amblystoma*, which is a more favorable form for the study of corneal formation than *Rana*. The experiments enable me to consider only the early stages of corneal formation, namely: (1) The thinning of the ectoderm of the corneal area; (2) the clearing of this ectoderm and loss of its pigment; (3) the formation of the endothelial layer of the cornea, which is in reality the anterior wall of the anterior chamber of the eye.

In addition to the above conclusions some of my more recent experiments show that the cornea will form from ectoderm other than that which normally gives rise to the cornea.

This spring I have repeated most of the experiments on *Amblystoma* and find that it is easy to confirm all of the conclusions stated above. Some new experiments show that even after the

<sup>1</sup> Am. Jour. of Anat., vol. iii.

cornea is formed it will disappear almost completely if the optic cup and lens are entirely removed, without injury to the overlying cornea.

The experiments in this paper with the sole exception of MD<sub>4</sub> have been selected each from a series of several similar ones.

#### METHODS.

Embryos of various ages were operated upon under the binocular microscope. Either ordinary tap water or a 0.2 per cent salt solution was used. The older embryos were first anesthetized with acetone-chloroform. The embryos were held with a pair of fine forceps, and the incisions were made with a very small pair of scissors, the points of which were ground with great care. Ordinary needles complete the instruments needed. The manipulation requires considerable practice, but one soon finds experiments possible, which at the beginning seemed beyond such methods. The method possesses great advantages over the use of the hot needle or electric cautery. A new and very wide field of work is opened by means of this dissection method and it will undoubtedly throw much light upon developmental processes.

The embryos were killed in Zenker's fluid, cut into serial sections 5  $\mu$  or 10  $\mu$  in thickness and stained in hematoxylin and Congo red.

The operations were all performed on the right side. The figures are all from photo-micrographs of transverse sections through the region of the right eye.

#### EXPERIMENTS.

##### *A. Non-development of the Cornea after Total Extirpation of the Eye.*

The numerous experiments on *Rana palustris* where the optic vesicle was completely removed at an early stage before lens formation and consequently long before there are any indications of corneal formation, have all failed to show corneal changes in the ectoderm which under normal conditions would have formed corneas. Even days after the operation and long after the cornea on the normal side of the head was well developed all traces of

corneal clearing of the ectoderm were wanting in the skin covering the region from which the eye had been taken. I have already given an experiment of this nature in my article on the origin of the lens in *Rana palustris*.<sup>1</sup> In this embryo a skin-flap was turned forward from over the optic vesicle, the latter cut away and the flap returned to its original position without injury to the corneal area of the ectoderm. The embryo was killed eleven days after the operation but showed no signs of corneal changes on the side operated on, while upon the normal side there was a well-developed cornea. In other experiments similarly performed only a portion of the optic vesicle was cut away and over the regenerated eye corneal formation took place provided the regenerated eye was of sufficient size to come into contact with the skin. It is evident then that the lack of corneal formation after complete extirpation of the eye was not due to the turning forward of the skin-flap. If a skin-flap is turned forward from over the eye and then replaced without injury to either it or the eye, perfectly normal development of the eye, lens and cornea will ensue. A deeply situated regenerated eye separated from the ectoderm by mesenchyme will not cause corneal formation.

In similar experiments on *Rana sylvatica* like results follow total or partial extirpation of the eye.

In *Amblystoma punctatum* the corneal changes are much easier to follow than in *Rana* as the ordinary ectoderm is of considerable thickness and the contrast between it and the cornea much greater than in the frog.

In *Amblystoma* as in frog larvæ the early total extirpation of the optic vesicle, before the period of lens formation, results in the failure of corneal development. For example, if in an embryo at this stage a flap of skin is carefully turned forward from over the eye, the optic vesicle completely cut away, and the uninjured skin-flap returned to its original position, it readily heals in place but no traces of corneal formation are to be observed even sixteen days after the operation. Fig. 1 gives an accurate idea of the conditions in such experiments. The lens also is entirely wanting while on the normal unoperated side optic cup, lens and cornea are present. The endothelial layer of the cornea likewise fails to develop without the presence of the optic cup.

<sup>1</sup> Am. Jour. of Anat., vol. iii, p. 512, Fig. 9.

If at a much later stage, namely, shortly after separation of the lens from the ectoderm, both optic cup and lens are taken out in a manner similar to that just described, corneal changes fail to develop, even if the embryos are allowed to live from twelve to eighteen days after the operation. (See Fig. 1, from Experiment XIV<sup>356</sup>.)

The end result as regards non-development of the cornea is the same in each embryo, whether the eye is taken out before the lens begins to form or shortly after its separation from the skin.

In *Amblystoma*, as in *Rana*, however, corneal formation occurs after partial extirpation of the eye, whether this is done before the lens has formed or shortly after its separation from the ectoderm, provided the regenerated eye comes into contact with the ectoderm. The mere lifting of the skin-flap here as in *Rana* does not interfere with corneal formation, so that the lack of corneal development after complete extirpation of the eye is not due to the lifting of the skin-flap but must be in some manner associated with the absence of the eye. It is evident that the cornea is not a self-differentiating structure.

#### *B. Rudimentary Corneal Area after Late Extirpation of the Eye.*

If in *Amblystoma* the optic cup and lens are taken out sometime after the separation of the lens from the ectoderm but before corneal changes are visible on the surface of the embryo a small clear corneal area will develop in the region where the large normal cornea would have formed. An examination of a normal embryo of the same stage at which the operation was performed shows that corneal changes have begun and consist in a slight thinning of the ectoderm over the eye. The endothelial layer is also in the process of formation. The operations consist in making an incision about the caudal side of the eye and then carefully turning forward the skin-flap from over it without injury to the corneal region. The eye and lens were then cut out and the skin-flap turned back into place where it readily healed. A few days after the operation a small clear corneal area appears in the ectoderm of the corneal region. An examination of the sections shows that this clear area differs from the ordinary ectoderm surrounding it in that it is much thinner, the pigment is wanting and the ectodermal cells have lost or not acquired the

usual vacuolization. It is in general like the normal corneal ectoderm except in being somewhat thicker. The rudimentary corneal area, however, never seems to become much larger than that pictured in Fig. 2, even twenty days after the operation. This experiment ( $Mn_4$ ) is only one of several in which almost exactly similar results were obtained as regards the development of the small corneal area.

In most of these experiments the rudimentary cornea is at the bottom of a depression in the ectoderm as in Experiment  $Mn_4$  (Fig. 2). Such depressed areas occur, however, without corneal changes. (See Fig. 3, Experiment  $ME_2$ .) In this experiment ( $ME_2$ ) the optic cup was removed some time before the separation of the lens from the ectoderm. The lens has been pinched off from the skin and has become separated from the latter by mesenchyme. The lens is, however, very much smaller than the normal one on the other side of the head. The embryo was killed 16 days after the operation and there is no trace of corneal formation even at the bottom of the depressed ectodermal area. The depression of the ectoderm then can scarcely be looked upon as a factor in its clearing.

In explanation of these rudimentary corneal areas it may be that the influences causing corneal formation had, at the time of the removal of the eye, not been acting long enough on the ectoderm to enable the clearing process to go on independently and form the normal sized cornea. A longer continued influence of the eye is evidently necessary for normal corneal formation and as will be shown later on it is necessary for the eye to be present even after the cornea is well formed if the latter is to continue its existence. It may be that the cornea can never maintain itself independently of the eye; however, farther experimentation is necessary to determine this point. Here it again becomes apparent that the cornea of normal size is not a self-differentiating structure.

### *C. The Size of the Cornea is Dependent upon the Size of the Eye.*

In the various experiments where portions of the eye have been cut away the regenerated eyes even thirty days after the operation fail to reach the size of the one on the normal side, unless the amount cut away is very small. The size of the regenerated eye is somewhat in proportion to the amount of eye stuff left

behind so that the new eye is to be viewed more as a re-formation than a regeneration. Such a regenerated eye coming into contact with the epidermis causes corneal clearing, the area of which varies in size with that of the eye. If but a small portion of the optic vesicle is cut away the regenerated eye will be of nearly normal size, with a cornea in all respects normal except of slightly less diameter to correspond to the smaller diameter of the eye.

If more of the optic vesicle is cut away a still smaller regenerated eye and cornea will result. In Experiment VII<sub>301</sub> (Fig. 4), the somewhat irregular optic cup is about three-quarters of the diameter of the normal one and the cornea about two-thirds of the diameter of the normal cornea. In other respects the cornea is like the normal one. The lens which is nearly as large as the normal one is still adherent to the retina and fills the entire posterior chamber of the eye. This is not an uncommon condition of the lens in the regenerated eyes even as late as eighteen days after the operation.

If a still greater portion of the optic cup is cut away a regenerated eye less than one-half the diameter of the normal one may develop with a correspondingly small cornea. In Experiment VII<sub>33</sub>, (Fig. 5), the small irregular optic cup contains a large lens which fills completely the cup cavity. The endothelial layer stretches over the lens and is for the most part in contact with it. The cornea although but one-half the normal diameter is in other respects like the normal one on the opposite side.

Even more of the optic vesicle may be cut away than in the preceding experiments, yet if the small regenerated eye remains in contact with the skin a very small corneal area will develop.

In the above experiments an incision was made around the caudal part of the eye and the skin-flap with lens attached turned forward. Varying amounts of the optic cup were cut away and the skin-flap with the lens attached turned back into the original position where it readily healed.

In another series of experiments both lens and optic cup were turned forward with the skin-flap and then varying amounts of the deep portion of the eye cut away. The skin-flap with the lens and remainder of the optic cup were then turned back into position. The re-formed eyes vary in size according to the amount left attached to the skin-flap, and the cornea in each embryo also varies in size with the size of the re-formed eye.

In still another series of experiments a portion of the optic cup together with the lens and all of the epidermis over the eye were cut away. In these experiments new epidermis soon covers the remainder of the eye and from it the cornea develops, and here, too, the size of the cornea varies with the size of the eye. This formation of cornea from strange ectoderm will be treated more fully in another section.

The area of the corneal clearing of the epidermis over the optic cup alone or over the naked lens is likewise in proportion to the size of the area of contact of these organs with the skin. A large optic cup may be so situated that only one small corner of it is superficial and in contact with the epidermis. The size of the corneal clearing is in proportion to this area of contact and not in proportion to the size of the eye.

*D. Corneal Formation with the Optic Cup Alone and Without the Lens.*

In order to analyze more completely the influence of the eye on corneal formation I have in the following series of experiments excluded the possible influence of the lens and find that the early stages of corneal formation will develop without the presence of a lens or without a lens ever having formed from the skin. This last point is illustrated by a single fortunate experiment (MD<sub>4</sub>) on *Amblystoma*. A skin-flap was turned forward from over the eye in the usual manner at a time when in normal embryos of the same stage the skin is just beginning to show signs of thickening for lens formation. A portion of the shallow optic cup was cut out and the skin-flap replaced. The sections show that for some reason the regenerated eye failed to cause lens formation, but nevertheless corneal formation is present (Fig. 6). The optic cup is contracted and the cavity much reduced in size, the pupil is small and the endothelial layer of the anterior chamber reduced in area. The transparent corneal area is smaller than normal and slightly thicker.

If at a somewhat later stage after the lens has formed and separated from the skin, but before there is any corneal clearing, a skin-flap is turned forward and the lens with part of the cup cut out, a small cornea will form over the small optic cup provided the latter is close under the skin. (See Fig. 7, from Experiment



MF<sub>2</sub>.) The contracted cup with small cavity and pupil presents a similar appearance to the condition seen in Experiment MD<sub>4</sub>. The extent of the endothelium and of the cornea correspond in size with the cup. The cornea is somewhat thicker than the normal one on the opposite side of the head, but otherwise similar to it.

I have numerous other similar experiments giving like results. In these experiments the optic cup or its endothelial membrane lie close to the corneal clearing, which corresponds in size with the area of contact. If, however, the optic cup and its endothelial membrane lie somewhat deeply buried and separated from the ectoderm by mesenchyme the corneal clearing fails to develop.

The formation of the cornea is then neither dependent upon the formation of a lens nor upon the presence of the lens.

#### *E. Small Corneal Clearing over the Superficial Naked Lens.*

If in *Amblystoma* the optic cup is taken out about the time of, or shortly after, the separation of the lens from the skin and the lens left in position close against the skin, a small clear corneal area will develop immediately over the naked lens. In such experiments there was at the time of the operation no trace of cornea and if both optic cup and lens are taken out the small area of corneal clearing does not appear.

An incision was made about the caudal two-thirds of the eye and the whole eye and skin-flap turned forward together. The optic cup was then carefully removed, leaving the lens *in situ* and the skin-flap with the lens attached turned back into its normal position.

At about the time when corneal clearing appears on the normal side the skin over the lens clears also, but is limited to the area immediately over the lens. As both epidermis and lens become perfectly transparent one can look down into the depths of the head in the living animal. The lens in most of the embryos is considerably smaller than the one on the normal side and often shows degeneration changes. The endothelial layer does not develop about the naked lens. The corneal area does not seem to spread beyond the extent of the contact area of the lens, nor

does the skin become as thin as that of the normal cornea. The pigment disappears and the large vacuolated cells which are present in the surrounding ectoderm are absent. (See Fig. 8, Experiment MG<sub>4</sub>.)

If, however, the lens is disturbed by the operation so that mesenchyme grows in between it and the skin, the corneal changes do not occur. (See Fig. 9, from Experiment Ma<sub>1</sub>, and Fig. 3, from Experiment ME<sub>2</sub>.)

If after the optic cup is taken out the lens is transplanted a short distance from the normal position, the mesenchyme often separates the lens from ectoderm and in such experiments the corneal clearing likewise fails to develop, and a condition similar to that seen in Fig. 9 is present.

#### *F. Corneal Formation from Strange Ectoderm.*

If the ectoderm covering the optic cup and lens is completely torn away at a stage shortly after the separation of the lens from the ectoderm but before there are any visible corneal changes, the wound thus formed will heal by the ingrowth of ectoderm from the sides of the denuded area. In many of the experiments there was more or less disintegration of the optic cup before the wound healed. In some almost the entire optic vesicle disappears; in others but little of it is lost. In the experiments where the optic vesicle remains of sufficient size to come into contact with the new ectoderm true corneal formation follows, the size of the cornea varying with the size of the eye. In Experiment XV<sub>362</sub> (Fig. 10), there was very little loss of optic vesicle substance and the new ectoderm soon covered the entire denuded area. The cornea with its endothelial membrane is apparently normal except in size being of less extent than the normal in proportion as the eye is smaller than normal. The new cornea was not well developed until about four days after the normal one on the left side had become perfectly clear. The difference in time in the formation of the corneas on the normal and operated sides may be even much greater than this, as when there is considerable disintegration of the eye, after the skin is torn off from over it, healing may be delayed a day or so and the eye much reduced in size. In some of these experiments the corneal clearing may be delayed from four to eight days after the one on the normal side is

perfectly clear. And more than eight days may elapse before all of the pigment cells are gone.

In another experiment performed in a similar way (XV<sub>366</sub>) there was considerable disintegration of the eye before the new skin completely covered over the denuded area. The eye is about one-half the diameter of the normal one and the clear corneal area even smaller in size. The various layers of the retina are irregular and the lens also. The latter fills the posterior chamber of the eye and has a process projecting into the pupil. (Fig. 11.)

In these experiments as in those in which a portion of the optic cup was cut away without injury to the overlying skin, the size of the corneal area is in direct proportion to the area of contact of the underlying eye.

In these experiments the skin that grows over the eye is at first opaque and shows no signs of clearing. Pigment cells are scattered through it as in the ordinary epidermis. This condition often remains until long after the cornea on the normal side is well formed and clear. The clearing of the new epidermis which has grown over the eye is usually a slow process, and a few pigment cells are especially prone to remain even for a long time after the skin has cleared.

If not only the skin from over the eye is cut away but with it is taken the lens and even the lens and part of the optic cup the adjoining skin will slowly cover the optic cup and after considerable delay a cornea will form over this optic cup, the lens being absent. The size of the cornea varies with the size of the re-formed eye. Here, too, the corneal formation is much retarded and only appears days after the one on the normal side is well formed.

If too much of the optic cup is taken away with the lens, what remains may be so deeply buried that it does not come into contact with the skin. In such embryos the cornea does not develop. (See Fig. 12, from Experiment XVII<sub>316</sub>.)

If skin, lens, and optic cup are completely removed, new epidermis will cover over the large wound but corneal changes fail to appear even four weeks after the cornea has developed on the normal side. So we can scarcely look upon the cornea in the above experiments as a product of regeneration, but must consider it as a new product from skin other than that which normally gives rise to a cornea.

*G. Degeneration of the Cornea after Extirpation of the Optic Cup and Lens.*

If after the cornea is well formed an incision is made dorsal to the eye and the optic cup with the lens taken out, care being taken not to injure the cornea, the large cornea will gradually disappear. At first instead of forming a bulge on the surface of the head there results a depressed area owing to the absence of the optic cup. At the bottom of this area is the corneal clearing. This corneal area gradually contracts and pigment cells invade it from the adjoining skin, and in some of the experiments there is scarcely a trace of the cornea left 30 days after the operation.

CONCLUSION.

It seems very probable that the optic vesicle brings about lens formation through a specific influence. The cornea, however, in so far as its early stages are concerned, namely, the thinning and clearing of the skin and loss of pigment can hardly be ascribed to a specific influence. That the mechanical pressure of the eye, or cup or lens may in some way be accountable for the corneal changes is a possibility. I am more inclined to the view, however, that the changes are due to another and quite different reason. The contact of either the eye or cup or lens with the epidermal cells must of necessity alter the environment of the overlying cells as regards their relation to the mesenchyme. It is possible that this exclusion from contact with the mesenchyme cells may be responsible for changes in the metabolism of the epidermal cells and cause them thereby to alter their mode of development, such alteration leading to corneal changes. That such apparently slight alterations in environment are responsible for other important changes in the history of embryonic ectodermal cells I think quite probable. From some experiments already completed it seems highly probable that the central nervous system is in part at least dependent for its origin and differentiation on the difference of environment of cells which at one time possessed the possibilities of producing either ordinary epidermal cells or of producing nerve cells.

SUMMARY (AMBLYSTOMA.)

1. A normal cornea will not develop without the eye.
2. The size of the cornea varies with the size of the eye, with the area of contact between it and the skin.
3. Contact between eye and skin is a necessary factor, as an eye separated from the skin by mesenchyme will not cause corneal formation.
4. The optic cup alone (without the lens) can cause corneal formation.
5. The lens alone (without the optic cup) can cause corneal formation, provided, as is the case with the optic cup, it is in contact with the skin.
6. The size of the corneal area over the optic cup or lens is dependent upon the area of contact between these structures and the ectoderm.
7. It is not necessary that the lens should be first formed from the skin in order to have corneal formation.
8. The cornea will develop from strange epidermis other than that which normally forms the cornea.
9. After the cornea is once formed it degenerates and disappears after extirpation of the rest of the eye.
10. The cornea is neither predetermined nor self-differentiating.
11. The cornea is dependent upon the correlation between the eye and the overlying ectoderm for its origin.

## EXPLANATION OF PLATES.

## PLATE I.

Fig. 1. Experiment XIV<sub>356</sub>. Right optic cup and lens taken out shortly after separation of the latter from the skin. Embryo killed 11 days after the operation. Figure from section through right eye region. A bit of the optic cup with nerve is deeply buried near optic foramen. No traces of corneal formation. The normal left side has a well developed cornea.  $\times 80$  diameters.

Fig. 2. Experiment Mn<sub>4</sub>. Right optic cup and lens taken out at a somewhat later period than the above, but before there were visible corneal changes. Embryo killed 12 days after the operation. Figure from section through the right eye region. A small depressed area of corneal clearing is seen, which is scarcely  $\frac{1}{10}$  the diameter of the normal cornea on the left side.  $\times 80$  diameters.

Fig. 3. Experiment ME<sub>2</sub>. Right optic cup removed shortly before the separation of the lens from the skin. Embryo killed 16 days after the operation. Figure from section through the right eye region. The lens, much smaller than normal, is separated from the ectoderm by mesenchyme. There are no corneal changes in the epidermis. On the left side the cornea is large and well formed.  $\times 80$  diameters.

Fig. 4. Experiment VII<sub>361</sub>. A portion of the right optic cup cut away before corneal formation. Embryo killed 9 days after the operation. Figure shows irregular eye smaller than normal with correspondingly small cornea.  $\times 80$  diameters.

Fig. 5. Experiment VII<sub>3</sub>. Operation as above except that more of the optic vesicle was cut away. Figure shows small eye and cornea.  $\times 80$  diameters.

Fig. 6. Experiment MD<sub>4</sub>. Portion of eye cut away before lens formation. Embryo killed 12 days after the operation. Figure shows absence of lens, small eye with small cavity and pupil, and corneal formation over the optic cup.  $\times 80$  diameters.

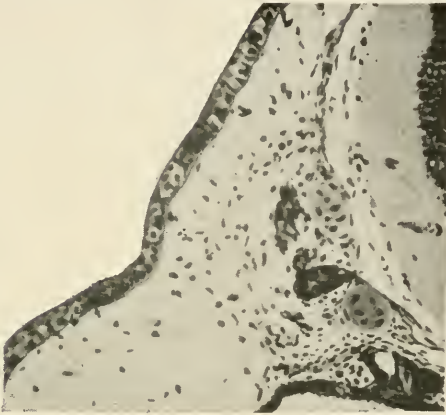

1



2



3

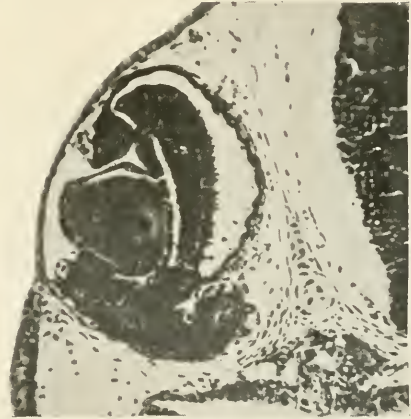

4

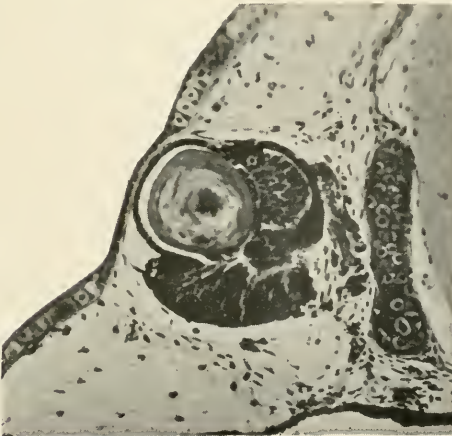

5



6







## PLATE II.

Fig. 7. Experiment MF<sub>2</sub>. Lens and part of optic cup removed shortly after the separation of the lens from the skin. Embryo killed 14 days after the operation. Figure from section through right eye region, shows the regular reformed optic cup with small cavity and pupil, and overlying cornea with its endothelium.  $\times 80$  diameters.

Fig. 8. Experiment MG<sub>4</sub>. Right optic cup removed shortly after separation of lens from skin, but before corneal formation. Embryo killed 13 days after the operation. Figure from section through the right eye region, shows a lens smaller than normal pressed close against the skin, where there is distinct corneal clearing, but no endothelial formation.  $\times 80$  diameters.

Fig. 9. Experiment Ma<sub>1</sub>. Operation as above except that the lens was disturbed. Embryo killed 13 days after the operation. Figure shows the small lens separated from the skin by mesenchyme. There are no corneal changes in this region nor endothelial formation. A small mass of eye-cells lies medial to the lens.  $\times 80$  diameters.

Fig. 10. Experiment XV<sub>362</sub>. Epidermis from over the entire right eye cut off before traces of corneal formation present. Embryo killed 11 days after the operation. Figure from a transverse section of the right eye region shows how new skin has completely covered the eye and become transformed into cornea.  $\times 80$  diameters.

Fig. 11. Experiment XV<sub>366</sub>. All of the skin over the eye and a portion of the optic cup removed. Embryo killed 11 days after the operation. Figure shows small eye with irregular lens and corneal formation from the new skin.  $\times 80$  diameters.

Fig. 12. Experiment XVII<sub>316</sub>. All of the skin over the eye, the lens and part of the optic cup cut away before corneal formation. Embryo killed 11 days after the operation. Figure shows deep optic cup without pupil or cavity separated from skin by mesenchyme. There are no traces of corneal formation in the new ectoderm.  $\times 80$  diameters.

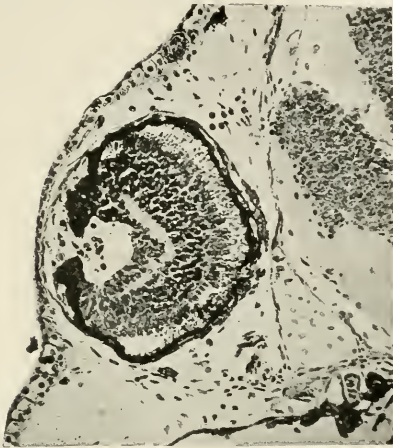

7

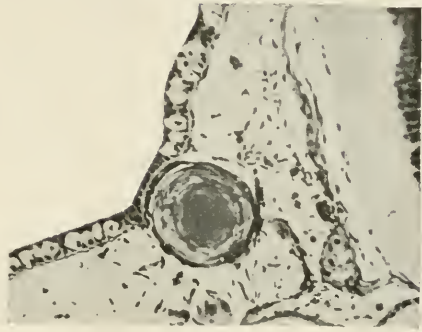

8

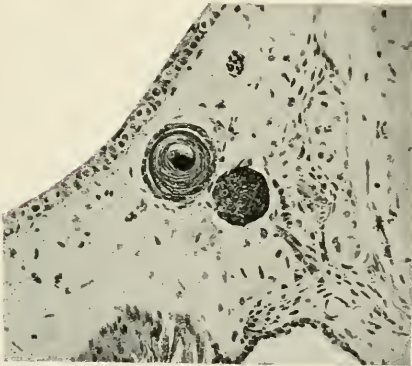

9



10



11



12



# MODIFIABILITY IN BEHAVIOR.

## I. BEHAVIOR OF SEA ANEMONES.

BY

H. S. JENNINGS.

A thorough study of the modifiability of reactions to external stimuli in lower organisms seems at present one of the great desiderata in the study of animal behavior. Recent work has been devoted largely to the study of sharply defined forms of reaction and to the discovery of conditions under which these forms appear in the typical way. As a result there is a widespread impression that the behavior of lower organisms is composed of invariable reflexes, occurring always in the same way under the same external circumstances. This is far from the truth and leads, as it seems to the writer, to a fundamentally false conception of the nature of animal behavior. Inner states and changes are fully as important in determining behavior as are external stimuli, modifying fundamentally the reactions which the latter produce. The present studies are devoted to an analysis of some of these modifying factors; in other words to some of the inner factors in behavior.

The study of the behavior of sea anemones herewith presented was made possible by a stay at the Carnegie Research Laboratory at the Tortugas. I am under great obligations to the Carnegie Institution and to the director of the laboratory, Dr. A. G. Mayer, for opportunity to carry on the work, and for supplying every facility that could assist it. The Tortugas laboratory furnishes an ideal situation for carrying on such investigations. An indefinite number of species of sea anemones and corals can be procured at a few moments notice, and they live as well in the laboratory as in the sea, since the water becomes cooler instead of warmer when brought into the house.

## I. CHANGES IN BEHAVIOR DUE TO VARYING STATES OF METABOLISM.

Nagel ('92) and Parker ('96) have shown that the food reaction of actinians toward weak stimuli becomes changed on repetition of the stimulation. A *Metridium* or an *Adamsia* at first readily takes filter paper soaked in dilute juice of crab meat. But after this has been fed several times in alternation with pieces of meat, the reaction to the filter paper becomes slower, and finally ceases, while the meat is taken as readily as before. Torrey ('04) shows that in *Sagartia* the state of hunger or satiety determines largely the reaction to small solid bodies. A very hungry *Sagartia* readily swallows inert bodies, such as filter paper and sand grains, while a fairly well fed one rejects these, though it takes meat. Has this effect of hunger and satiety any connection with the changes observed by Nagel and Parker, or are these of a different character? What relation have they to the changes due to experience in higher animals? The whole problem of the changes induced in behavior by changing metabolic states is one of the greatest importance for an understanding of the adjustment or regulation produced in behavior. I have attempted to study this matter carefully in a number of sea anemones, and to distinguish modifications due to this cause from those which result from other factors.

*Stoichactis Helianthus.*

This large sea anemone has often a disk 10 to 15 cm. in diameter. This is covered closely with short tentacles of uniform size, about 8 mm. in length.<sup>1</sup> *Stoichactis* is voracious; it is usually when captured ready to take large quantities of crushed crab appendages. To three specimens I fed piece by piece nearly all of three good sized ghost crabs (*Ocypode*). The food reaction depends on contact with the meat itself—that is, on chemical stimuli in combination with contact. Hard parts of the crab, or other indifferent objects, are usually not taken, though in rare cases even filter paper is swallowed.

Food is taken in the following way: If a piece of crab's leg, with some of the flesh exposed, is placed on the disk of a hungry

<sup>1</sup>For photographs of the disk of *Stoichactis*, see Duerden, 1902, Pl. 1.

specimen, the tentacles immediately surrounding it (including many not in contact with it) begin suddenly to wave back and forth. After an instant this usually ceases, and all is absolutely quiet for a few seconds. Then the movement begins again. All the tentacles that in their waving motion come in contact with the food, bend over against it and shrink, in such a way as to hold it down against the disk. Now that portion of the disk bearing the food begins to sink inward, by a folding of the surface. The mouth, which may be 4 or 5 cm. distant, begins to open, and the walls of the esophagus protrude from the mouth as large bladderly lobes. The region between the mouth and the food body begins to contract, the tentacles borne here collapsing and almost completely effacing themselves. By this contraction the mouth and food approach each other, the intervening region disappearing. Meanwhile other parts of the disk swell and their tentacles become plump and enlarged; this appears to be a secondary phenomenon due to the squeezing of the internal fluid from the contracted region to other parts. The esophageal lobes increase in size, becoming 2 to 4 cm. long, and half as thick; they extend toward the food, finally reaching it. By the contractions and expansions already mentioned the mouth may be moved from the center of a disk 10 cm. in diameter to within 1 cm. of the edge. By this time mouth and food may be hidden beneath the surface of the contracted disk, though in other cases they lie on the surface in plain view. Now the esophageal lobes extend over and around the food, while the tentacles progressively withdraw from it until the food body is lying on the contracted portion of the disk, completely covered by the esophageal lobes. Next that part of the disk beneath the food withdraws, involving an enlargement and further displacement of the mouth, till there is nothing beneath the food body, and it is pressed by the esophageal lobes into the internal cavity. The whole reaction is thus very complex.

Twenty or more pieces of crab, including entire large appendages, may thus be successively taken, till the body of the anemone has become a mere stretched sack full of crab appendages. But in the later reactions of a series the process of food-taking becomes much slower, the animal seeming to become gradually satiated. The food may be taken by the tentacles and held for a long time before it is finally moved to the mouth. In other cases the ten-

tacles do not react for some minutes, the food lying on the disk undisturbed, until finally it is slowly taken. Sometimes there is an interesting combination of the positive food reaction and the negative reaction (to be described later). The food is taken by the tentacles and carried very slowly to the mouth, in the way above described, while the mouth opens and the esophageal lobes are protruded. But when the food body reaches the lobes, or sometimes before, the process stops. The food is released by the tentacles, and is finally carried away and rejected, in the way to be described. Finally, when the animal seems fully satiated, the piece of crab meat may be rejected as soon as it comes in contact with the disk. But after one or more pieces have been rejected one may sometimes see another piece accepted. The internal state is in a condition of most unstable equilibrium, and may easily incline toward the positive or the negative reaction.

Thus it is clear that in *Stoichactis* the reaction to a given stimulus is by no means a set, invariable property of the organism, but depends on the state of the internal processes. To the same stimulus we may get a quick positive reaction or a quick negative reaction; a slow and deferred positive reaction or a combination of the positive and negative reactions.

Peculiar effects are observed when several pieces of meat are placed at the same time on different parts of the disk. If the animal is hungry all are carried to the mouth; the entire disk folds inward and the pieces are swallowed simultaneously or successively. I have seen six pieces, placed as far apart on the large disk as possible, thus ingested. When the animal is less hungry the results are different. In some cases, when two pieces of meat are placed on the disk, one is swallowed while the other is rejected. If the rejected piece is again placed on the disk after the first piece has been disposed of, it will sometimes be swallowed.

Adding new pieces while swallowing is in progress often produces interference. Thus, in one case two pieces of meat, *a* and *b*, were placed near opposite edges of the disk. Both began to approach the mouth in the usual food reaction. Now two new pieces, *c* and *d*, were placed near the edge midway between *a* and *b*. Thereupon the reaction to *a* and *b* ceased, while *d* was transported to the edge of the disk (about 2 cm.) and dropped off. Now the food reaction was resumed, *a*, *b* and *c* traveling toward the mouth.



Piece *d* was now replaced on the disk. The reaction to the other pieces was suspended, and *d* was carried to the mouth. Here it came against the middle of the esophageal lobe that was extending toward *a*,—in such a way that *d* could not well be ingested without a rearrangement of the lobes. Thereupon *d* was again carried away from the mouth and once more dropped over the edge of the disk. The other pieces were now successively swallowed. Piece *d* was readily swallowed when given to another specimen.

*The Rejecting Reaction.*—After *Stoichactis* has become satiated, it rejects food, as we have seen. The rejecting reaction presents a number of points of much interest. By this same reaction the disk is kept clean when débris falls upon it. If a mass of waste matter of any sort (as a mass of dead plankton or a quantity of sand) is placed on the disk of *Stoichactis*, measures are set in operation which result, within ten or fifteen minutes, in removing this material and leaving the disk free. The behavior in bringing about this result is complex and the operation may be accomplished in more than one way.

The tentacles bearing the débris or the rejected food body collapse, becoming thin and slender, and lying flat against the disk. At the same time the disk surface in this region begins to stretch, separating the collapsed tentacles widely. As a result the waste mass is left on a smooth, exposed surface, the tentacles here having practically disappeared—though under usual conditions they form a close investment almost completely hiding the surface of the disk. Thus the waste mass is fully exposed to the action of waves or currents, and the slightest disturbance in the water washes it off. Under natural conditions this must usually result in an immediate removal of the débris. If this does not occur at once, often the region on which the débris is resting begins to swell, and becomes a strongly convex, smooth elevation, thus rendering the washing away of the mass still easier.

But the process may go much farther. If the débris is not removed in the way just described, new reactions set in. If the mass is nearer one edge of the disk this edge usually begins to sink, while at the same time the tentacles between the edge and the waste object collapse and practically efface themselves. Thus a smooth, sloping surface is produced and the waste mass slides off the disk. If this does not occur at once, after a little time the

region lying behind the mass (between it and the center of the disk) begins to swell, producing a high, rounded elevation, with tentacles plump and swollen. The waste mass is now on a steep slope, and is bound soon to slide down and over the edge. Sometimes by a continuation of this process the entire disk comes to take a strongly inclined position, with the side bearing the débris below. Often one portion of the edge of the disk after another is lowered in this way, till all the waste matter has been removed. The disk then resumes its horizontal position, with nearly flat or slightly concave surface.

Sometimes the edge bearing the débris cannot be lowered, owing to the fact that it is almost against an elevation in the irregular rock to which the anemone is attached. In this case, after perhaps an attempt to bend the edge downward, the part between the edge and the waste body swells and rises, rolling the mass toward the center, while at the same time the region between it and the center sinks down. The sinking continues till it reaches the opposite edge, so that the mass is rolled across the disk to the opposite side and there dropped off the disk. The process is slow, often taking fifteen minutes to half an hour.

The rejecting reaction is characterized by great flexibility and variability. The débris or refused food sets in operation certain activities; if these do not remove the source of stimulation, other activities are induced until one is successful.

Thus in *Stoichactis* the same stimulus—crab's meat—may in the same individual produce sometimes the long train of activities resulting in the ingestion of food; in other cases the complicated and variable behavior resulting in rejection, in still others a combination of the two. The deciding factor is internal—the condition of the metabolic processes.

#### *Aiptasia.*

Two species of *Aiptasia* were studied. One was *Aiptasia annulata* Les.; the other a smaller and darker species, with shorter tentacles, which I have been unable to identify with certainty. I shall call it *Aiptasia* No. 2. Both came from the moat surrounding Fort Jefferson. Rather small specimens, with columns 4 to 10 cm. in length, were used in most of the work.

The species of *Aiptasia* are relatively active and quick-moving anemones. Especially is this true of *Aiptasia annulata*. If the tip of one of the long tentacles is touched, the whole disk and column shrinks with a sudden quick contraction, reminding one of the rapid contraction of a medusa. To the eye all parts of the body appear to contract at once. Often the disk and column have contracted strongly before the actual contraction wave has made any apparent progress from the tip of the long tentacle to the disk. Certainly in this animal the general contraction does not appear to be due to a spreading of an actual contraction wave from one part of the animal to another, through the actual pulling of one region upon the neighboring one, as it does in *Hydra*, and according to Torrey ('04), in *Sagartia*. On the contrary, there seems certainly to exist some rapid method of conduction, suggesting nervous action.

In *Aiptasia annulata* the use of India ink indicates the presence of cilia driving a current away from the mouth and toward the tip of the tentacles, as in *Metridium*.

*Aiptasia annulata* usually takes crab meat or filter paper soaked in the juices of such meat, but refuses neutral bodies, such as plain filter paper or sand. *Aiptasia* No. 2, on the other hand, is usually prepared to swallow readily balls of plain filter paper and other small neutral bodies, as well as crab meat. This furnishes opportunity for some interesting comparative experiments.

Food is taken in the following way: If a small object comes in contact with a tentacle it adheres to the surface, and the tentacle contracts strongly, the whole animal usually contracting at the same time. Then the tentacle bends over and places the food with considerable precision on the mouth. The tentacles near by likewise bend over and are applied to the food body, holding it down against the mouth. This happens even when the body is quite neutral, as plain filter paper, so that the bending of the neighboring tentacles is clearly due to some influence transmitted from the one tentacle in contact with the body. The mouth now opens, the lips protruding a little and seizing the food, while the tentacles may release it and bend away. But sometimes the tentacles follow the food into the mouth and their tips remain enclosed for some time. The actual swallowing of the food is mainly due to the activities of the lips and esophagus; it may occur without any intervention of the tentacles, when the food is placed directly on

the mouth. A piece of meat or filter paper may be completely enclosed by either species within ten seconds of the time it comes in contact with a tentacle.

With these two species of *Aiptasia* the experiments of Nagel and Parker, mentioned on page 448, were repeated and varied, with somewhat peculiar results. Pieces of crab meat and of filter paper (plain or soaked in juice of crab meat) were given alternately to the individual under experimentation. In *Metridium* and *Adamsia*, as we have noted, the animal soon comes to reject the filter paper, while still accepting the meat.

In *Aiptasia annulata* a typical experiment is as follows: The animal is fed alternately filter paper soaked in crab juice and crab meat. Both are taken readily till four pieces of each have been ingested. At the fifth piece of paper—the ninth piece of the whole series—the animal balks and rejects it. But it likewise rejects the immediately following fifth piece of meat! It has evidently lost its hunger, and refuses to take anything. This is the usual result with *Aiptasia annulata*.

In *Aiptasia* No. 2 plain filter paper (not soaked in crab juice) was given alternately with pieces of crab meat. In a typical experiment six pieces of filter paper and six of meat were taken in regular alternation. But the seventh piece of paper and the immediately following seventh piece of meat were rejected.

The results above given are the usual ones. But sometimes, though rarely, results are reached which are analogous to those attained in *Metridium* by Parker. Thus, in one case a specimen of *Aiptasia annulata* accepted the first piece of plain paper, but thereafter refused paper consistently, while accepting meat offered in regular alternation with it.

For all these results the following explanation suggests itself: The animals when hungry take both meat and filter paper; when satiated they take neither. Usually the tendency to take both ceases at the same point, but sometimes the reaction to the weaker stimulus (filter paper) ceases before that to the stronger stimulus—as a higher animal that is not hungry may refuse most things, while accepting peculiarly tempting morsels.

If the degree of hunger is thus the determining factor, then it should be possible to produce the rejection of the filter paper by feeding meat alone. This turns out to be the case. Indeed, usually the rejection of filter paper may be induced more readily

by feeding meat alone than by feeding the two alternately, or than even by feeding filter paper alone. Thus, two specimens of *Aiptasia* No. 2, which we will call A and B, living side by side, were both found to take plain filter paper readily. Then A was fed alternately meat and filter paper, while B was fed successive pieces of meat. After eight pieces had thus been fed to each, A still took filter paper (though slowly), while B refused it absolutely—though B would still slowly take a piece of meat. Thus B, through satisfying its hunger with meat, had come to reject filter paper, while A still accepted it after devouring several pieces. Apparently meat is more satisfying to sea anemones than is filter paper!

In another case a specimen of the same species was fed filter paper alone. It swallowed ten pieces in succession, till the body was puffed out with them, meanwhile ejecting some of the pieces already swallowed, in the intervals between the taking of new ones.

In *Aiptasia annulata* similar relations were found. The animal could be caused to reject filter paper soaked in crab juice much more readily by feeding it meat alone than by feeding soaked paper alone, or by feeding the two in alternation. A large number of comparative experiments were tried, showing this result to be general. It is therefore clear that the state of hunger or satiety is the essential factor in this behavior, in *Aiptasia*.

The experiments showed further that it is not the mere mechanical fullness of the digestive cavity that determines acceptance or rejection, but some change in the metabolic processes themselves. Filling the digestive cavity with filter paper does not have the same effect in producing rejection as does filling it with meat. Even when the cavity is so filled that pieces of paper are repeatedly disgorged, new pieces are readily taken. In *Aiptasia* No. 2, a piece of paper that has been disgorged after remaining some time in the cavity, is usually swallowed again immediately, if it is returned to the disk.

As the animal becomes less hungry the details of the behavior toward food bodies change greatly. In a hungry specimen, as we have seen, the food reaction is rapid, often requiring but ten to fifteen seconds. After several pieces of meat have been ingested the reaction of all parts becomes much slower and less precise. The tentacles touched by the food may not react at all for several seconds; then they bend in a rather languid way toward the

mouth, while the surrounding tentacles may quite omit their reaction. The food body is not placed so accurately upon the mouth as in the hungry individual. At a further stage toward satiation, a piece of crab meat applied to the tentacles induces either no reaction at all or a straight withdrawal—a negative reaction; they may then bend back from the disk along the column. If the meat is placed directly on the disk, in contact with the mouth, the latter may very slowly open and in a languid way partly or entirely enclose the food, even when there is no reaction of the tentacles. The mouth is thus usually readier to give the food reaction than are the tentacles.

In this condition of approaching satiation some peculiar combinations and alternations of positive and negative reactions may be observed. In a specimen of *Aiptasia* No. 2 after five pieces of alternate meat and paper had been taken, another piece of paper was swallowed, then after one and one-half minutes this was disgorged. The disgorged piece lay on the disk for a few seconds, then the mouth opened and began swallowing it again. But after it was about half enclosed, it was again rejected. Now it was grasped again and partly re-swallowed, then again rejected. This performance was repeated once more before this piece of paper was definitely rejected. A fresh piece of paper presented immediately after was slowly swallowed, then in two minutes disgorged. The anemone presented exactly the spectacle which we should interpret in a higher organism as a struggle between desire and repugnance for the available food.

In another case a piece of meat was presented after six pieces had been swallowed. The tentacles reacted only very slowly, but finally deposited the piece of meat on the disk, and withdrew. The mouth opened part way, then closed again without ingesting the food. Later it opened again a very little and enclosed a minute shred of the meat between its lips. The piece was thus quietly held for ten minutes, when it was seen to be sinking imperceptibly. Fifteen minutes after it was given it was completely enclosed. Many other cases were seen of partial rejection and acceptance of the same piece of meat. At times after one piece has been rejected, another is accepted.

In *Adamsia* and *Metridium*, according to Nagel ('92) and Parker ('96), after the tentacles of a certain region of the disk have through repeated trials come to reject soaked filter paper,

those of another part of the same disk will still carry it to the mouth. This shows clearly that a general lack of hunger on the part of the organism as a whole cannot be the only factor involved. In *Aiptasia* No. 2 I tried experiments to determine whether there was the same independence in the tentacles of different regions. Crab meat was given to the tentacles of the left side; these carried it to the mouth, where it was swallowed, the tentacles of the right side playing no part in the reaction. After the tentacles of the left side had taken five pieces they reacted very slowly, a piece of meat resting against them for several seconds before it was seized. When it was finally carried to the mouth, however, it was swallowed readily. The next piece of meat, not being seized at once by the left tentacles, was transferred to those of the right side. They seized it instantly and quickly carried it to the mouth. Thus it is clear that the experience of the individual tentacles plays some part in the behavior; either from fatigue or some other cause, tentacles frequently stimulated gradually lose the tendency to respond. The fact that this result is produced by meat, the purest form of food, seems to indicate that fatigue may be the cause.

But the rest of the experiment indicates that this plays only a minor part in the change of behavior. After a short rest the giving of food to the tentacles of the left side was resumed. They continued to carry it slowly and with much delay to the mouth, where it was very slowly swallowed. After taking four more pieces, the tentacles of the left side absolutely refused to carry any more food to the mouth. The mouth had now almost ceased taking food when directly applied to it, though after some minutes the food was finally ingested. Now a piece of meat was given to the tentacles of the right side, which had only reacted once, and that more than fifteen minutes ago. Yet they behaved in exactly the same way as did the others, refusing to react at all, save by hanging back from the disk along the column.

Thus it is clear that the animal is a unit so far as hunger and satiety are concerned. If the satiety has arisen through the activity of the tentacles of one side, the tentacles of the other side are equally affected by it. It is the general progress of metabolism that is the chief factor in determining the reactions to food.

As Torrey ('04) has already noted for *Sagartia*, the reactions of satiated sea anemones differ in many other ways from those of

hungry specimens. The well fed animal reacts much less readily and strongly to simple mechanical shock. If touched with a needle the well fed individual of *Aiptasia* either does not react at all, or contracts very slightly, while the hungry specimen reacts suddenly and powerfully. A slight disturbance in the water has no effect on the well fed individual, while the hungry one contracts strongly. To chemical stimuli the same relations apply. A much stronger solution of any given chemical is required in order to produce contraction in the well fed individual, as compared with the hungry one. The bearing of such facts on quantitative determinations in reaction work is evident. If we should attempt to determine the strength of a given chemical which causes contraction in *Aiptasia*, we should obtain totally different results, according as we used specimens that were very hungry, moderately hungry, or thoroughly satiated. No "normal" concentration for causing reaction could be determined for even a single given specimen, for the state of metabolism, and with it the tendency to react, is continually changing.

It is, of course, clear that the change due to varying metabolic states cannot be interpreted alone as a general increase or decrease of sensitiveness. Much more significant is the complete qualitative change in the nature of the reaction to a certain stimulus, due to this cause, which we have seen both in *Stoichactis* and in *Aiptasia*.

## 2. ACCLIMATIZATION TO STIMULI.

Sea anemones show acclimatization to stimuli in the same way as do the protozoan *Stentor* and many other low organisms. A light stimulus that is not injurious may cause at first a strong reaction, then on repetition produce no reaction at all, or a very slight one. This is easily shown with *Aiptasia annulata* in the following way: A specimen is selected with outspread disk close beneath the surface of the water. From a height of about 30 cm. a drop of water is allowed to fall on the water surface just above the disk. At once the animal contracts strongly. Waiting till it has expanded again, another drop is allowed to fall in the same way. As a rule there is no reaction to this or to succeeding drops. Sometimes there is a response to the first two or even three drops, but usually there is no reaction after the first one. A slight



reaction of a different sort, that often comes on later, will be mentioned in the next section.

Experiment shows that the failure to respond is practically universal if the drops fall three minutes or less apart. With drops five minutes apart there is still marked evidence of acclimatization, though irregularities appear. With drops falling at intervals of more than five minutes I was unable to satisfy myself with certainty that acclimatization occurs.

Related to the present subject are changes in the reaction to light. *Aiptasia annulata* is very sensitive to light, expanding in darkness, but contracting after a few seconds when exposed to strong light. In ordinary daylight the animal remains contracted for some hours, but after such a period most specimens extend in spite of the light. In comparative darkness the animals direct the disk toward the source of light, through a contraction on the side of the column exposed to the light. After remaining undisturbed for a long time in an aquarium that is fairly well lighted, the animals give up their orientation with respect to the strongest source of light; with less light they retain it.

### 3. REACTIONS MODIFIED AS A RESULT OF THE PAST EXPERIENCES OF THE ORGANISM.

Under this head will be considered all positive changes in reaction, due to former stimuli or former reactions of the organism, aside from those due to changes in metabolism.

We have already described certain cases belonging here. In the reaction by which the disk is kept clean in *Stoichactis* we find that a mass of débris on the disk causes first one reaction, then another, till one of these or a combination of several rids the animal of the stimulating agent (see p. 451). In this case either the continuation of the same stimulus, or the fact that a certain reaction has been given, induces a new reaction, without change in the external conditions.

A similar phenomenon is often seen in the experiments with falling drops of water, described above. To the first drop the animal responds by a sudden sharp contraction, then to a considerable number of drops there is no response. Now if the drops continue, the animal usually begins to shrink slowly away from the region where the drops are falling, so that in the course of time the

disk has been withdrawn some distance below the surface, though no decided reaction has occurred to any one stimulus. These facts are precisely parallel to those which I have described in a previous paper (1902, p. 50) for the infusorian *Stentor*.

More marked changes result when the animal is stimulated by light strokes of a rod. At the first stroke on the disk *Aiptasia* contracts strongly. It then extends in the same direction as before. When it is fully extended the stimulus is repeated. The animal responds in the same way as at first. This is usually continued for about ten or fifteen stimulations, the animal each time extending in the same direction as at first. But at length, when stimulated anew, the animal contracts, bends over to one side, and extends in a new direction. Under natural conditions, where stimulation at every extension would usually be due to some fixed object, this would of course put an end to the series of stimuli. If, however, the stimuli are still continued after each extension, the animal repeats for a number of times the extension in the new direction, then finally turns again and tries a new position.

This may be repeated many times. But in the course of time the reaction becomes changed in a still different manner. The anemone releases its foothold and moves to a new region. This result I have not succeeded in attaining by striking the animal with a rod each time it extends; the time required is evidently to be measured in hours. But obstructions may be so placed that every time the animal extends, the disk strikes against a solid body. In such a case it is usually found after a few hours that the animal has moved to a new region.

Thus to the same stimulus when repeated many times the anemone reacts first by contraction, then by turning repeatedly into new positions, then by moving away. The phenomena are parallel to those described by the present author ('02) for the infusorian *Stentor*, and by Wagner ('05) for *Hydra*. Beyond doubt other stimuli would here, as in *Hydra* and *Stentor*, produce the same series of reactions.

In the behavior just described there are at times certain phenomena which bear a striking resemblance to the formation of new habits. *Aiptasia annulata* frequently extends its body in most awkward turns, the column retaining an irregular and crooked form. This is evidently due to its method of life. The animal lives in irregular crevices and crannies beneath stones or in the

hollows of the coral reefs. In order that its disk may protrude into the free water, it is often compelled to extend in the irregular way mentioned, and to retain the crooked forms thus reached. When removed from the natural habitat it still retains these irregularities of form and action. The lower part of the column may stand at right angles to the upper part, or there may be permanent S-shaped bends, or still more irregular forms. It would appear that these must have arisen as a result of the way in which it extends in its natural habitat. The peculiar methods of extension found in given individuals could then hardly be characterized otherwise than as habits, the peculiarities of form being the structural correlates of the habits.

In searching for experiments that would test the possibility of the formation of new habits in sea anemones, the following suggested itself. It should be possible to produce new habits in *Aiptasia* by so arranging the surroundings as to compel the animal to extend in a new way whenever it extends, and to retain the new form thus induced. If the animal when thus compelled by obstacles to extend in a new direction, still extends in the same direction after the obstacles are removed, one would be inclined to hold that a new habit had been formed.

I supposed that this result would require a long period of time. But some preliminary experiments showed it to be attained, in some cases, with such absolute ease as to raise the doubt whether we have here anything that can be called habit formation. Thus an individual attached to a plane horizontal glass surface was bent in extension far over to the left. Stimulating it repeatedly, it contracted at each stimulation, then bent, in extending, again to the left. This continued for fifteen stimulations, one succeeding another as soon as the animal had become fully extended. At the next contraction the animal turned and bent over to the right. Now when stimulated it contracted as before, then bent regularly, in extending, over to the right. It seemed to have acquired a new habit—bending to the right instead of to the left.

Attentive examination showed that when the animal contracted in response to stimulation, the concave side of the column contracted a little more than the rest, so that that side remained a little shorter. In other words, the animal did not take on an entirely symmetrical structure, but the region which was most contracted in extension remained most contracted also in the con-

tracted animal. Now on expanding, all parts extended more or less proportionately to their extension in the contracted animal, so that the original curved form was regained. In other words, the structural conditions resulting in the curved form were not really given up even in contraction, and were only made evident when extension occurred.

If the animal was compelled by repeated strong stimulation to contract maximally in all parts, then in extension there was no greater tendency to bend in the direction previously occupied than in any other. And in about half the individuals this result followed (after once the first habitual position found in nature had been given up) even after a single stimulation, so that there was no indication of anything like the formation of a new habit.

What is the interpretation to be given to the numerous cases in which bending in a certain direction when extended *does* induce, in the way set forth above, bending in the same direction on a new extension? Is this the formation of a habit? It is certainly a condition of affairs that gives the same result as habit formation. The anemone might indeed be looked upon as a sort of structural model, illustrating the principles on which habit formation might occur. A certain action (extension in a certain direction) leaves structural peculiarities, persisting even in the intervals of action (in the contracted state), which result in a repetition of the same action. Is not this the picture that we commonly make for ourselves of the real nature of habit formation? In the sea anemone this seems to occur in a relatively gross way, but it appears difficult to point out any difference in principle between this and habit formation. If the persisting structural peculiarities were of such a nature as to be hidden from observation, there would be no ground for hesitation in calling these phenomena the formation of habits. There can hardly be doubt that the striking individual peculiarities of action and structure, described above, have arisen in precisely this way, so that it plays the part taken by habit formation in higher animals.

It would be well if the study of this matter could be extended to the same individual for a long time, beginning with a young, still regular, specimen, compelling it to live in a position where it would have to extend in a definite irregular way. In this way the development of the structural correlates of the habits (?) could doubtless be observed.

The facts may be summed up for the anemone as follows: Performance of a certain action involves the assumption of certain structural conditions. These conditions persist in a slight degree even in the intervals between the actions. At a new action they show their influence by causing it to take place in the same way as the former one. This gives the same results as what we are accustomed to call habit.

#### 4. GENERAL AND COMPARATIVE.

The sea anemones are among the lowest of the Metazoa, and their behavior, when compared with that of most other animals, is of a very simple character. Yet it is evident that even in these low organisms the reaction to a given external stimulus depends upon many things beside the nature of the stimulus itself. Varying states of metabolism induce totally different reactions to the same stimulus, one state producing the long train of actions looking toward the ingestion of food, another inducing the equally long and variable chain of activities resulting in rejection. The same factors cause marked changes in reaction to other stimuli than possible food. Past stimuli received and past reactions performed likewise determine the reaction to a given external condition, resulting sometimes in a cessation of reaction, in other cases in a complete change in its character. Certain simple conditions produce a tendency in the organism to perform more readily an act previously performed (bending, on extension, in a certain direction).

Examination of the conditions under which the animals live shows clearly that all the usual reactions and modifications of the reactions are such as to assist in adapting the organism to its environment. In other words, they aid the physiological processes of which the organism is the seat. *Aiptasia annulata*, for example, lives in crevices beneath and among stones or coral rocks. It is, of course, evident that its food reactions maintain its metabolic processes, which would necessarily cease in their absence, that the rejecting reaction keeps the surface clean, so that respiration may take place uninterruptedly, and obstacles or injurious substances be avoided. The transformation of the food reaction into the rejecting reaction after the animal is satiated with food is of course as much to the interest of the sea anemone as it is to that of higher

animals. If the food reaction were an invariable reflex, occurring whenever food is present, without regard to internal conditions, the results would be disastrous. The fact that the very hungry animal will take indifferent bodies that would otherwise be rejected is of course likewise adaptive; as Torrey ('04) remarks "substances with a very small food value must be of some importance to a starving polyp although they would not be desirable as food to a well nourished animal."

The tendency of *Aiptasia* to remain in the dark and to contract when strongly lighted keeps it in the crevices where it finds protection for its soft body. The fact that it faces and bends toward the lighted side keeps its tentacles and disk directed toward the entrance to the crevice, where food may be captured; if they were directed toward the darkest part of the crevice little or no food would be obtained. While the contraction under light is protective, it would result, if continued indefinitely by a lighted polyp, in starvation; we find that after a considerable period of light the animal extends. In correlation with its life in irregular crevices or under stones we find that *Aiptasia* does not take any definite position with reference to gravity, as some other anemones do. Such a reaction would render its usual habitat impossible. The tendency to react by a quick contraction when there is a slight disturbance in the water is undoubtedly protective. Yet such a disturbance when not followed by an attack from its author is not harmful and the animal under such circumstances quickly resumes its usual behavior, even though the disturbance continues. But such a disturbance maintained indefinitely would result in loss of opportunity for obtaining food, and the animal after a time shrinks gradually away from such a disturbed region. Injurious stimuli, interfering with the natural physiological processes of the polyp, cause contraction—the animal withdrawing from the field of action for a time. But this continued indefinitely would result in a loss of food and doubtless other injurious effects. We find that the animal has recourse then to extension in another direction, and finally to creeping away and establishing itself elsewhere. Located in an irregular crevice, we find that the polyp extends in various directions, until it finds a direction in which its disk and tentacles are unimpeded in their spreading to form a trap for prey. It then continues to extend in this manner, even though this may require the body to bend at right angles or to take other irregular

forms. It continues to extend in this manner even when removed from its irregular crevice, and the body is found to have become structurally modified, so that a collection of *Aiptasias* shows many crooked and zigzag shapes, each being an adaptation to the crevice in which the animal lived. The formation of such habitual methods of extension can be imitated and modified in the laboratory.

All together, the activities and their modifications are clearly such as to directly adjust the organism to its environment, enabling the physiological processes to continue under all sorts of conditions. It has become the fashion to neglect such facts, but they fairly force themselves on the attention of the careful student of the behavior, and their existence can hardly be held to be accidental. To remove such an organism to the artificial conditions of the laboratory and then endeavor to understand its behavior is like dissecting an internal organ out of the body and trying to understand its functions when thus separated from the other structures with which it interacts. Almost everything the animal does has a direct relation to something in its usual environment, and when cut off from this environment, its activities are likely to become unintelligible. One can hardly resist the belief that the fact that these activities do assist the physiological processes of the organisms has determined their selection and retention from among other possible activities.

This adaptation and adaptive modifiability of behavior in sea anemones and their relatives has not been explicitly set forth in most works dealing with their reactions. Yet when other careful accounts of behavior in such organisms are analyzed we can discover such relations as clearly as in *Aiptasia*. Let us look for example at the cases of *Hydra*, studied by Wagner ('05), and of *Cerianthus*, as described in the classical papers of Loeb ('91). It will be found instructive to consider the conditions on which the retention of a certain position depends. *Hydra* and the sea anemones tend as a rule to retain a position at rest, with the foot attached and head free. This usual position is often said to be due to a reaction to gravity, or to contact, or to some other simple stimulus. But when we examine into the matter closely, we find that it is not an entirely simple one. Let us take first the case of *Hydra*. Suppose the animal is placed on a horizontal surface with head downward and foot upward. It does not retain this

position, but bends the body, placing the foot against the bottom, releases its head, and straightens upward. *Aiptasia* shows the same reaction. In neither of these animals is the reaction due to a tendency to keep the body in a certain position with reference to gravity, for both keep the body indifferently in any position with reference to the pull of gravity, provided that the foot is attached and the disk and tentacles can be spread freely. To what then is the reaction due? Evidently there is a tendency to keep the foot in contact with a surface, for the body of the inverted *Hydra* is bent till the foot comes in contact. There is likewise a tendency to keep the head free, for it is released. But this is not all, for now the body is straightened, then the tentacles are spread out symmetrically in all directions. It is clear that the reaction is directed toward getting the organism into a position that may be called "normal," and this normal position has various factors—attachment of foot, freedom of head, comparative straightness of body, and tentacles outspread.

Suppose now that our *Hydra* has reached this position, and all the conditions remain constant; is this sufficient? We find that it is not. If the conditions remain so constant that no food is obtained, the *Hydra* becomes restless and changes the position of its body repeatedly, though still retaining its attachment by the foot. Later even this is given up, and the animal, of its own internal impulse, quite reverses the position attained through the "righting reaction." It now bends the body, attaches the head, and releases its foot, thus bringing it back into the inverted position.

Is this because the irritability of head and foot have become reversed, so that the head now tends to remain attached, the foot free? Apparently not, for no sooner has the animal taken the inverted position than it draws its foot forward and now performs the "righting reaction" again, so that it stands once more on its foot. These alternations of behavior are repeated, and we find that by this means the animal is moving from place to place (see Wagner, 1905, Fig. 3).

It seems clearly impossible to refer each of these acts or the whole behavior to any particular present external stimulus. An internal state—hunger—drives the *Hydra* to move to another region, and these different opposite acts are the means by which another region is reached. Each phase of the locomotion is



evidently partly determined by the fact that a certain other phase has just been performed, partly by the general state of hunger. The same behavior is shown by Hydra under continued injurious stimuli of different sorts.

In speaking of righting reactions, it is often said that the organism is *forced* by the different irritabilities of diverse parts of the body to take a certain orientation with reference to gravity or to the surface of contact (see for example Loeb, 1900, p. 184). The facts just brought out (taken from Wagner) show that we cannot in Hydra consider this orientation forced, save in the general sense that all things which occur may be considered forced—including of course the behavior of man. Man takes sometimes a sitting position, sometimes a standing one, sometimes a reclining one, depending upon his "physiological state" and past history, and the facts are quite parallel for Hydra. So far as objective evidence shows, the behavior is not forced in Hydra in any other sense than it is in man. Both organisms take that position which seems best adapted to the requirements of their physiological processes; these requirements vary from time to time.

In the sea anemone *Cerianthus* the conditions for staying in a certain position are somewhat more complex than in Hydra, according to the account given by Loeb (1891). *Cerianthus* is usually found in an upright position, inhabiting a tube made of mucus and imbedded in the sand. If placed head downward in a test tube, it rights itself in the same way as Hydra and *Aiptasia*, freeing the head, bringing the foot into contact, and straightening the body. But in *Cerianthus* Loeb showed clearly that gravity plays a part in the behavior. If the animal is placed on its side on a wire screen of large mesh, it bends its foot down through the meshes, lifts up its head, and takes its usual position with reference to gravity. If now the screen is turned over, the animal again directs its head upward, its foot downward—as a human being under similar circumstances would do if possible. It may thus weave itself in and out through the meshes.

But to be in line with gravity, with head above and free, is not the only requirement for *Cerianthus*. Loeb found that it would not remain indefinitely in this position on the wire screen, as it does in the sand. After a day or so it pulls its foot out of the wire and seeks a new abode. Only when it can get the surface of the body in contact with something, as is the case when it is imbedded

in the sand—in its natural habitat—is it at rest. If this condition is fulfilled, the requirement of the usual position in line with gravity may be neglected. Loeb found that when the animal is placed in a test tube, so that its body is in contact with the sides, it remains here indefinitely, *even though the tube is placed in a horizontal position* (Loeb, 1891, p. 54). The head is bent upward, but the body remains transverse to the direction of gravity.

Examples of the fact that a certain orientation with reference to gravity is not a rigid requirement even in animals that usually or at times react to this agent, are common among sea anemones and other lower organisms. Thus, Torrey ('04) shows that *Sagartia*, though it usually maintains an upright position, may oftentimes take a position on the surface film, with head downward. In the rejecting reaction of *Stoichactis*, described on p. 451, we have clearly a reaction with reference to gravity, though one which even the most sanguine could hardly denominate a fixed tropism. The situation "waste - matter - on - the - disk - not - removed - by - the - first - (usual) - reaction" is responded to by taking such a position with reference to gravity as results in removing the waste; then the reaction to gravity ceases. This is somewhat analogous to the reaction to gravity described by Bohn (1903) in the hermit crab. While investigating a shell which it may adopt as a home if fitting, this animal takes up a certain position with reference to gravity—namely, with the body on the steepest slope of the shell, and head downward; it then turns the shell over and ceases to react with reference to gravity. Of a different but equally significant character are the variations shown in the reactions to gravity by the low acelous flatworm *Convoluta*, as described by Bohn ('03b) and Gamble and Keeble ('03). Under conditions that are favorable *Convoluta* remains on the surface of the sand. But when the sun becomes hot, or when the tide rises, so that the animal is likely to be washed away, it becomes "positively geotropic," going downward in the sand, where it is protected. When the tide falls again *Convoluta* becomes "negatively geotropic," thus reaching the surface of the sand, where it obtains food and carries on its usual activities. These alternations of reaction become a fixed habit with *Convoluta*, so that when removed to an aquarium it still goes downward at high tide, upward at low tide, though the conditions surrounding it remain constant; it may thus be used for a time as an in-door tide indicator. Gradually, however, when

removed for a long time from the influence of the tides, this alternation of reactions to gravity ceases, showing it to be a true habit, resulting from individual experience. Many other instances of reactions to gravity, of the most diverse sorts and variable character, could be given. Gravity affects organisms in many diverse ways—determining the distribution of internal substances of differing specific gravity, causing differences in the ease of movements in diverse directions, inducing strains or pressure in unaccustomed parts of the body when an unusual position is taken—indeed, influencing the life processes in almost every detail. Any of the points at which it comes in contact with the life processes may serve as the basis for a reaction, so that we find behavior induced by relations to gravity in different organisms to be of the most diverse character. We have been assured by various writers that the reaction to gravity must be explained in the same way in all cases, but this is evidently said rather in the capacity of a seer or prophet, than in the capacity of a man of science whose conclusions are inductions from observation and experiment.

Returning to *Cerianthus*, we find, according to Loeb, that even the usual position in line with gravity and with sides in contact, does not satisfy the animal indefinitely, if left quite undisturbed. If it secures no food it again leaves its place and seeks another region.

Thus in order that *Cerianthus* may remain quiet in a given position, a considerable number of conditions should be fulfilled, constituting the usual, and perhaps what we may call the "normal" state of affairs for this animal. These conditions are the following: (1) The foot should be in contact; (2) the head should be free; (3) the body should be straight; (4) the axis of the body should be in line with gravity, with the head above; (5) the general body surface should be in contact; (6) food should be received at intervals. If these conditions are largely unfulfilled, the animal becomes restless, moves about, and finds a new position. But no one of these conditions is an absolute requirement at all times, unless it be that of having the head free. In the wire screen the animal remains for a day or two in the required position with reference to gravity, even though foot and body surface are not in contact. In the horizontal tube it remains with foot and surface in contact, though the body is not straight nor in line with gravity. If all conditions are fulfilled save that of food, the animal remains for a time, then moves away.

Clearly, the holding of any given position depends, not on the relation of the body to any one or two sources of stimulation, but on the proper maintenance of the natural physiological processes of the organism. The actinian does not always maintain a certain position with relation to gravity, nor does it always keep its body straight, nor its foot in contact, nor its body surface in contact. It does not at all times receive food. It may remain quiet for considerable periods with one or more conditions lacking. The organism tends on the whole to take such a position as is most favorable to the unimpeded course of its natural physiological processes. Certain usually required conditions may be dispensed with provided other favorable ones are present. The behavior, like that of higher animals, represents a compromise of the various needs imposed upon the animal by its physiological processes.

Examination of the literature shows that throughout the Cœlenterates there is a similar dependence of behavior on the progress of the internal physiological processes, particularly those of metabolism. The state of metabolism decides whether *Hydra* shall creep upward to the surface or shall sink to the bottom (Wilson '91), how it shall react to chemical and to solid objects (Wagner '05), whether it shall remain quiet in a certain position, or shall reverse this position and undertake a laborious tour of exploration. In the sea anemones it determines, as we have seen, even the details of long trains of reaction. The state of the metabolic processes appears to be the most important determining factor in the behavior of Cœlenterates.

The same dependence of behavior on the internal physiological processes is found in other groups, even in those much lower than the Cœlenterates—the Protozoa, and particularly the Bacteria. This is brought out especially in some of the work of Engelmann. A number of examples of this relation will be given in the paper which follows the present one, so that they may be omitted here. The fact that in higher animals behavior depends largely on hunger and satiety is, of course, so well known that it need not detain us.

The relation of behavior to the internal physiological processes, of which we have given some examples in the foregoing pages, is manifestly of the greatest significance for the understanding of behavior. The facts adduced show directly that in many cases the determining factor in reactions to stimuli is not the anatomical configuration of the body, taken in connection with simple laws

of conduction, but is the relation of the action of the external agent to the internal processes. The problem presented by the fact that the same stimulus, in the same intensity, applied to the same part of the body, produces qualitatively different and even opposite results, depending on the inner metabolic states, seems not to have received the attention it deserves. It evidently places marked difficulties in the way of a simple mechanical conception of the reflex process, based merely on the anatomical structure of the organism. The internal physiological state determines in some way which of various courses within the body the transmitted stimulus shall follow and what organs it shall arouse to activity. The organism cannot be looked upon as a static structure, on which external agents must act in a simple invariable way. *The organism is a process*, and some of the chief determining factors in behavior are given by the relation of the internal to the external processes. As the internal processes change, the reaction to external agents changes correspondingly. We find that reactions which assist the existing internal processes are continued or repeated, while those which oppose them are changed. This gives one of the chief bases for the regulatory character of behavior, as I shall attempt to set forth in farther detail in the paper which follows the present one. The metabolic processes, while the most striking of those taking place in the lower organisms, are of course not the only ones occurring in animals. An immense number of other processes are in progress, and the relation of external agents to these processes may and does equally determine behavior. This gives the phenomena of behavior their complexity, preventing them from being in relations of *simple* dependence on external agents, as they are often represented of late. Such a view quite underestimates the difficulty of the problem of behavior. The dependence on external agents exists, but is complex, and can usually not be predicted without a knowledge of the present internal state of the organism—this depending on its past history and the course of its various internal processes.

It would of course be more convenient if the problems of behavior were as simple as they are often proclaimed to be. Work revealing their complexity is naturally not received with the acclaim that greets the announcement that all these things are simple and easy. But if our object is really to obtain control of the vital processes, then we must face them in all their com-

plexity. To control animal behavior it is necessary to study animal nature, in much the same way that it is necessary to study human nature in order to control human behavior. It is necessary to know the past history of the organisms, and what is going on within them, in order to predict what they will do. He who expects even the lower animals to behave always in certain simple invariable ways when acted upon by the various forces of nature has many disappointments in store, when he comes to make a thorough study of the matter. The internal modifying conditions must be made the object of deliberate and extended investigation in lower animals as well as in higher ones, before the study of behavior can be placed on a really scientific basis.

## LITERATURE CITED.

- BOHN, G., '03.—De l'évolution des connaissances chez les animaux marins littoraux. Bull. Institut Général Psychologique, No. 6; 67 pages.
- '03.—b. Les *Convoluta roscoffensis* et la théorie des causes actuelles. Bull. Mus. d'Histoire Naturelle, pp. 352-364.
- DUERDEN, J. E., '02.—Report on the Actinians of Porto Rico. Bull. U. S. Fish Com., vol. xx, second part, pp. 323-374, 12 pl.
- GAMBLE, F. W., AND KEEBLE, F., '03.—The Bionomics of *Convoluta roscoffensis*, with Special Reference to Its Green Cells. Quart. Journ. Micr. Sci., vol. xlii, pp. 363-431.
- JENNINGS, H. S., '02.—Studies on Reactions to Stimuli in Unicellular Organisms. IX. On the Behavior of Fixed Infusoria (*Stentor* and *Vorticella*), with Special Reference to the Modifiability of Protozoan Reactions. Amer. Journ. Physiol., vol. viii, pp. 23-60.
- LOEB, J., '91.—Untersuchungen zur physiologischen Morphologie der Thiere. I. Ueber Heteromorphose, pp. 48-59.
- '00.—Comparative Physiology of the Brain and Comparative Psychology. 309 pages. New York.
- NAGEL, W., '92.—Das Geschmacksinn der Actinien. Zoöl. Anz., Bd. xv, S. 334-338.
- PARKER, G. H., '96.—The Reactions of *Metridium* to Food and Other Substances. Bull. Mus. Comp. Zoöl. at Harvard Col., vol. xxix, pp. 107-119.
- TORREY, H. B., '04.—On the Habits and Reactions of *Sagartia davisii*. Biol. Bull., vol. vi, pp. 203-216.
- WAGNER, G., '05.—On Some Movements and Reactions of *Hydra*. Quart. Journ. Micr. Sci., vol. xlviii, pp. 585-622.
- WILSON, E. B., '91.—The Heliotropism of *Hydra*. Amer. Natural., vol. xxv, pp. 413-433.

# THE METHOD OF REGULATION IN BEHAVIOR AND IN OTHER FIELDS.

BY

H. S. JENNINGS.

The results set forth in the preceding paper, together with certain other relations found in the behavior of lower organisms, that have been detailed in previous papers by the present writer, suggest a certain point of view in regard to the general method of regulation or adjustment in organisms. Everywhere in the study of life processes we meet the puzzle of regulation. Organisms do those things which advance their welfare. There are some exceptions, but this is certainly true in a general survey. If the environment changes, the organism changes to meet the new conditions. If the mammal is heated from without, it cools from within; if it is cooled from without it heats from within, maintaining the temperature that is to its advantage. The dog which is fed a starchy diet produces digestive juices that are rich in the enzymes which digest starch, while under a diet of meat it produces juices rich in proteid digesting substances. When a poison is injected into a mouse, the mouse produces substances which neutralize this poison. If a part of the organism is injured, a rearrangement of material follows till the injury is repaired. If a part is removed, it is restored, or the wound is at least closed up and healed, so that the life processes may continue without disturbance. Regulation constitutes perhaps the greatest problem of biology. How can the organism thus provide for its own needs? To put the question crudely, how does it know what to do when a difficulty arises, so as to overcome this difficulty? It seems to work toward a definite purpose. In other words, the final result of its action seems to be present in some way at the beginning, determining what the action shall be. In this the action of living things appears to contrast with that of things inorganic. It is regulation of this character that has given us the theories of vitalism. By these theories the principles controlling the life

processes are held to be of a character essentially different from anything found in the inorganic world.

Nowhere is regulation more striking than in the behavior of organisms. Indeed, the processes in this field have long served as the prototype for regulatory action. The organism moves and reacts, on the whole, in ways that are advantageous to it. If it gets into hot water, it takes measures to get out again, and the same is true if it gets into excessively cold water. If it enters an injurious chemical substance, it at once changes its behavior and escapes. If it lacks material for its metabolic processes, it sets in operation movements which secure such material, suspending these movements when the lack is fully supplied. If it lacks oxygen for respiration, it moves to a region where oxygen is found. If injured it flees to safer regions. In innumerable details it does those things which are good for it, and this is as true of the Protozoan as of the Metazoan. It is plain that behavior depends largely on the needs of the organism, and is of such a character as to satisfy these needs. In other words, behavior is adjustment or regulation.

There seems no reason to think that regulation in behavior is of a different character from that found elsewhere. But nowhere else is it possible to perceive so clearly how regulation occurs. In the behavior of the lowest organisms we can see not only what the animal does, but precisely how this happens to be regulatory. The method of regulation lies open before us. This method is of such a character as to suggest the possibility of its application to other fields; in other words, it suggests a possible general explanation of the method of regulation. This suggestion the present paper attempts to develop.

In the lower, unicellular, organisms where we can see just how regulation occurs, the process is as follows. Anything injurious to the organism causes changes in behavior. These changes subject the organism to new conditions. As long as the injurious condition continues, the changes in behavior continue. The first change in behavior may not be regulatory, nor the second, nor the third, nor the tenth. But if the changes continue, subjecting the organism successively to all possible different conditions, a condition will finally be reached that relieves the organism of the injurious action, provided such a condition exists. Thereupon the changes in behavior cease, and the organism remains in the



favorable condition. The movements of the organism when stimulated are such as to subject it to various conditions, one of which is selected.

This method of regulation is found in its purest form in unicellular organisms, such as *Paramœcium* and *Stentor*. Yet it occurs also in higher organisms, and indeed is found in a less primitive form throughout the animal series, up to and including man. When we ourselves, or other animals, are confronted with a difficulty for which neither experience nor inherited tendency has furnished us with a direct method of relief, the only recourse is to this same method of regulation. We perform movements which subject us to various conditions, till one is found that relieves the difficulty. We call the process searching, testing, trial, and the like. In the lowest and highest organisms the injurious condition acts as a stimulus to produce many movements, subjecting the organism to various conditions, one of which is selected.

In connection with this method of behavior three questions arise, which are fundamental for the theory of regulation. First, How is it determined what shall cause the changes in behavior that result in new conditions? Or why does the organism change its behavior under certain conditions, not under others? Second, How does it happen that such movements are produced as result in more favorable conditions? Third, How is the more favorable condition selected; what is this selection and what does it imply? Our first and third questions may indeed be condensed into one, which involves the essence of the regulatory process: Why does the organism choose certain conditions and reject others? This selection of the favorable conditions and rejection of the unfavorable ones presented by the movements is perhaps the fundamental point in regulation.

It is often maintained that this selection is precisely personal or conscious choice, and that behavior cannot be explained without this factor. Personal choice it evidently is, and in man it is often conscious choice; whether it is conscious in other animals we do not know. But in any case this does not remove it from the necessity for analysis. Whether conscious or unconscious, choice must be determined in some way, and it is the province of science to inquire as to how this determination occurs. To say that rejection is due to pain, acceptance to pleasure, or to other conscious states, does not help us, for we are then forced to inquire

why pain occurs under certain circumstances, pleasure under others. Surely this is not a haphazard matter! There must be some difference in the conditions to induce these differences in conscious states (if they exist) and at the same time to determine the differences in behavior. We are therefore thrown back upon the objective processes occurring. Why are certain conditions accepted, others rejected? This is essentially what has often been called the pleasure-pain problem.

Such facts as are set forth in the preceding paper give us a basis for an objective answer to this question. Organisms are not static structures; processes of complicated character are in continual progress within them. Among these the processes of metabolism are most prominent. Ostwald ('02) has emphasized the point that one of the chief characteristics of living matter is the fact that processes are occurring with much energy within it. The organism is a complex of processes. In the preceding paper we have seen that the reactions of organisms to external agents depend largely on the relation of the action of these agents to the internal processes.

Let us examine certain cases of this dependence in the simplest organisms—bacteria and protozoa. The green *Paramœcium bur-saria* requires oxygen in its metabolic processes. While swimming about it comes to a region where oxygen is lacking. It reacts by turning away and going in some other direction. The white *Paramœcium caudatum* does the same, and so also do many bacteria. All require oxygen in their metabolic processes; lack of oxygen interferes with these processes, and they react to such a lack by changing their movement and going elsewhere. But there are some bacteria that do not require oxygen in their metabolic processes. When these come to a region lacking oxygen they do not react, but keep on and enter this region. In many of these anaërobic bacteria oxygen is known actually to interfere with the physiological processes. When these bacteria come to a region containing oxygen, they change their movement and go elsewhere. In *Paramœcia* and the bacteria that require oxygen, this does not occur (unless the amount of oxygen rises above the optimum). In all these cases, whenever there is interference with the metabolic processes, the organism reacts by turning away, otherwise it does not. In the reactions of these creatures with reference to light and darkness we see the same thing. In the

green *Paramœcium bursaria*, in *Euglena*, and many other green infusoria, light assists the metabolic processes, while lack of light interferes with them, and the same is true of the so-called purple bacteria. All of these organisms react on coming to a region of darkness by turning away and going elsewhere. In the colorless *Paramœcium caudatum* and in the colorless bacteria ordinary light does not affect the metabolic processes, so that there is no interference with these processes in darkness, and we find that they do not react on reaching a dark region, but enter it readily. For all these organisms, colored and uncolored, light may be made so intense that it does interfere with the physiological processes, as is shown by the fact that the processes stop, the organisms dying. To such light all react by turning away—including even the colorless *Paramœcium caudatum*. We find in all of these cases that the animal reacts by turning away when there is interference with the physiological processes, and does not so react unless there is such interference.

In some cases the relation between behavior and the effect of an agent on the physiological processes is marvelously precise. Thus, Engelmann ('82) proved that in *Bacterium (Chromatium) photometricum* the ultra red and the yellow-orange rays are those which most favor metabolism (assimilation of carbon dioxide, etc.). When a microspectrum is thrown on a preparation of these bacteria, they are found to react in such a way as to collect in precisely the ultra red and the yellow-orange. The reaction consists in a change of behavior—a reversal of movement—at the moment of passing from the ultra red or the yellow-orange to other parts of the spectrum, while passing in the opposite direction produces no such effect. Bacteria are not in nature subjected to spectral colors in bands, so that there has been no opportunity for the production of this correspondence between behavior and favoring conditions through the selection of varying individuals.

What is the explanation of these facts? Why does the infusorian or the bacterium shrink back from darkness or the region containing no oxygen? As a matter of fact, it requires the light or the oxygen for the continuance of its metabolic processes, and it does not shrink back from a region lacking them unless it does need them. But we have no reason to attribute to the bacterium any knowledge or idea of that relation. We do not need any

purpose or idea in the mind of the organism, or any "psychoïd" or entelechy to account for the change of behavior, for an adequate objective cause exists. We know experimentally that the darkness or the lack of oxygen interferes with the metabolic processes. This very interference is then evidently the cause of the change of behavior. When anything interferes with the internal processes, running with much energy, the energy overflows in other directions, resulting in changes in behavior. This statement is a mere generalized formulation of the facts determined by observation and experiment in the most diverse organisms.

Internal as well as external interference may cause the changes of behavior. If oxygen or other material for metabolism is lacking to such an extent as to interfere with the metabolic processes, the organism changes its behavior. In the sea anemones, as we have seen in the preceding paper, this condition induces the animal to change its position and start off on a laborious tour of exploration. The initiation of changes in movement through internal conditions gives the basis for the reactions which we call positive, as we shall see.

The answer to our first question is then as follows: The organism changes its behavior as a result of interference with its physiological processes.

Our second question was: How does it happen that such movements are produced as bring about more favorable conditions? This question we have already answered, so far as many lower organisms are concerned, in our general statement on page 474. The organism does not go straight for a final end. It merely acts—in all sorts of ways possible to it—resulting in repeated changes in the conditions. In this way a condition is after a time reached that relieves the interference with the internal processes.

The nature of the changes in behavior produced—the movements that occur in any given organism—depend on what may be called the "action system" of the organism. The animal, in other words, performs the movements that it is accustomed to perform, as determined by its structure and its past history. The essential fact is that interference with the internal processes causes a *change* in behavior. The mere fact of a change under these conditions tends in itself to be regulatory. The original behavior has brought on the interfering conditions, hence the

best thing to do is to change this behavior. If the unfavorable condition still continues the behavior is changed again; this being continued, the organism is bound to escape from the interfering condition if it is possible to do so. In some cases the movements produced are, when considered by themselves, of a rather uniform character, yet are of such a nature as to subject the animal to many changes of the environmental conditions. This is the case for example in the reactions of such infusoria as *Paramœcium*, where the character of the movement is determined partly by structure, yet involves a continued change of relation to the outer conditions. In other cases the movements themselves are varied in character, the organism first reacts in one way, then in another, running through a whole series of activities, till one results in ridding the organism of the stimulating condition. This is the method of behavior seen in *Stentor* and in most higher organisms.

Our third question was: How does the organism select the more favorable condition thus reached? This question now answers itself. It was interference with the physiological processes that caused the changes in behavior. As soon, therefore, as this interference ceases, there is no further cause for change. The organism selects and retains the favorable condition reached merely by ceasing to change its behavior when interference ceases. This process is seen clearly in the behavior of such infusoria as *Paramœcium*.

It is perhaps fairly evident how reaction on the plan just described may result in the avoidance or rejection of sources of interfering stimuli; in other words, in the production of negative reactions. The matter of positive reactions should perhaps receive further elucidation.

In conditions that are completely favorable—so that all the life processes are taking place without lack or hindrance—there is no need, from the standpoint of regulation, for a change in behavior—for definite reactions of any sort. The most natural behavior on reaching such conditions, and that which is actually found as a rule among lower organisms, is a continuation of the activities already in progress. These activities have resulted in the favorable conditions, and there is no cause for a change. This we find exemplified in infusoria, bacteria, rotifers, and many other organisms, under most classes of conditions. A change in behavior takes place only when the activities tend to remove the

organism from the favorable conditions; in other words, to produce interference with the life processes. Unfavorable stimuli, in these organisms, cause a change in behavior; favorable stimuli cause none. It is perhaps a general rule in organisms, high or low, that continued completely favorable conditions do not lead to definite reactions. Of course while the external conditions remain the same, the internal processes may change in such a way that these conditions are no longer favorable, and now the behavior may change. This frequently happens.

When the organism is not completely enveloped by favorable conditions, but is on the boundary, if we may so express it, between favorable and unfavorable ones, there is often a definite change in the behavior leading toward the favorable conditions—a positive reaction. To understand such reactions, we may start from the fact, already mentioned, that unfavorable internal conditions (as well as external ones) cause a change of behavior. It is a general fact, for example, that the animal whose metabolic processes suffer interference from lack of material—the hungry animal—sets in operation trains of activity differing from the usual ones. Interference with respiration, or an increase in temperature above that favorable for the physiological processes, has similar effects. This is indeed a general rule for all internal changes interfering with the usual physiological processes.

But the activities thus induced are in themselves undirected, save by structural conditions. There is nothing in the cause producing them to direct them with reference to external things. Let us suppose, however, that certain of these movements lead to a condition which relieves the interference with the internal processes. The cause for a change of behavior is now removed, hence the organism continues its present movement. But perhaps later—sometimes at the very next instant—this same movement may tend to remove the organism from the favorable condition—as when a *Paramœcium* in a heated preparation passes across a small area of water cooled to the optimum, and reaches the opposite side, or when a hungry organism comes in contact with food, which will be lost if there is further movement. Thereupon the cause for a change—interference with the life processes—is again set in operation, and the present movement is changed. Thus the animal changes all behavior that leads away from the favorable condition, and continues that which tends to retain it, so that we

get what we call a positive reaction. The change of behavior is due in each case primarily to the unfavorable stimulation, internal or external. This style of behavior is seen with diagrammatic clearness in the free swimming infusoria. These animals continue their movements as long as they lead to favorable conditions, changing at once such movements as lead away. They thus retain favorable conditions by avoiding unfavorable ones; the positive reaction is seen to be, in a sense, a secondary result of negative ones.

We have a similar condition of affairs in the taking of food by *Amœba*. The animal moves forward with broad front, and comes in contact at a certain point on this front with a food body. Part of its movement is taking it away from the food, part toward the food. On coming in contact, all movement which takes it away is changed, only that being continued which keeps the animal in contact with the food. We have here then the same condition of affairs as in the infusoria—the selection of certain conditions through the rejection of all others.

This is perhaps the fundamental condition of affairs for organisms in general. In higher animals the positive, as well as the negative, reactions, have become complicated through the influences to be brought out later, so that this primitive condition is not evident. But the essential point is that unfavorable conditions are rejected as a result of the fact that they produce changes in behavior, and this results in the attainment and retention of favorable conditions. In negative reactions it is the new unfavorable external condition that is rejected, retaining the old favorable internal condition. In positive reactions it is the old unfavorable internal conditions that are rejected, retaining the new favorable external conditions. In both cases the impulse to change of movement comes from interference with the physiological processes—external interference in negative reactions, internal interference in positive reactions.

To sum up, in the lowest organisms we find individual adjustment or regulation on the basis of the three following facts:

1. Definite internal processes are occurring in organisms.
2. Interference with these processes causes a change of behavior and varied movements, subjecting the organism to many different conditions.
3. One of these conditions relieves the interference with the

internal processes, so that the changes in behavior cease, and the relieving condition is thus retained.

It is clear that regulation taking place in this way does not require that the end or purpose of the action shall function in any way as part of its cause, as some vitalistic theories hold. There is no objective evidence that a final aim is guiding the organism. None of the factors above mentioned appear to include anything differing in essential principle from such laws of causality as we find in the inorganic world.

Now an additional factor enters the problem. By the process which we have just considered, the organism reaches in time a movement that brings relief from the interfering conditions. This relieving response becomes fixed through the operation of a certain law which appears to hold throughout organic activities. This law may be stated as follows: An action performed or a physiological state reached, is performed or reached more readily after one or more repetitions, so that in time it becomes "habitual." The statement of this law just given is in reality not adequate, and it may be well to dwell upon it a moment, developing it farther, and pointing out some of the phenomena in which it is expressed. In previous papers, including the one immediately preceding the present, I have pointed out the fact that the behavior and reactions of an organism depend largely on "physiological states;" the same point has recently been emphasized by Bohn ('05). We may distinguish at least two great classes of physiological states—those depending on the metabolic processes of the organism, treated in detail in the preceding paper, and those otherwise determined. The physiological states of organisms change in accordance with certain laws. The changes in the metabolic states of course depend on the laws of metabolism. In the physiological states not directly dependent upon metabolism, but rather upon stimulation and upon the activity of the organism, such as are found in *Stentor* and *Planaria* (see Jennings, '04), we find certain fairly well defined laws of change that are of a peculiar character.

In the organisms just mentioned, and in many others, the following phenomena have been found. Under certain external conditions the organism reacts in a certain way. These conditions continuing, the organism changes its first reaction for a second, and then perhaps for a third and fourth. Later the same external conditions recur, and now the organism at once



responds, not by its first reaction, but by the final one. This is illustrated for unicellular organisms by the case of *Stentor*, for higher metazoa by the behavior of certain crustacea, as described by Yerkes ('02) and Spaulding ('04). There are certain differences between the two cases, but they are not essential for our present purpose.

How does this condition of affairs come about? As we have set forth in previous papers ('04), the different methods of reaction under the same external conditions must be due to different physiological states of the organism. The "physiological state" is evidently to be looked upon as a dynamic condition, not as a static one; it is a certain way in which the bodily processes are occurring; it tends directly to the production of some change. In this respect the "law of dynamogenesis," propounded for ideas of movement in man, applies to it (see Baldwin, '97, p. 167); ideas must indeed be considered, so far as their objective accompaniments are concerned, as certain physiological states in higher organisms. The changes toward which physiological states tend are of two kinds. First, the physiological state, like the idea, tends to produce movement. This movement often results in such a change of condition as destroys the physiological state producing it. But in case it does not, then the *second* tendency of the physiological state shows itself. It tends to resolve itself into another and different state. State 1 passes to state 2, and this again to state 3. This tendency shows itself even when the external conditions remain uniform.

In this second tendency there manifests itself the important law of which we have spoken above. When a certain physiological state has been resolved, through the action of an external agent, or otherwise, into a second physiological state, this resolution becomes easier, so that in the course of time it takes place more quickly, and even spontaneously.

This may be illustrated from the behavior of the unicellular organism *Stentor*, as described in previous papers by the present writer ('02 and '04), as follows: When the animal is stimulated by the flood of carmin grains (or in any other way), this produces immediately a certain physiological state corresponding to that accompanying a sensation in ourselves. This state we may designate A. It at first produces no reaction. As the carmin continues or is repeated, this state A passes to a second state

B, producing a bending to one side. After several repetitions of the stimulus, the state B passes to the state C, producing a reversal of the cilia, and this finally passes to D, resulting in a contraction of the body. Each state must of course be different from the preceding one, because it produces a different result. The course of the changes in physiological states may then be represented as follows:

$$A \longrightarrow B \longrightarrow C \longrightarrow D$$

Now we find that after many repetitions of the stimulation the animal contracts at once as soon as the carmine comes in contact with it. In other words, the first condition A (direct result of contact) passes at once to the state D, and this results in immediate contraction:

$$A \longrightarrow D$$

It seems probable that the same series occurs as before, save that B and C are now passed rapidly and in a modified way, so that they do not result in a reaction, but are resolved directly into D. The process would then be represented as follows:

$$A \longrightarrow B' \longrightarrow C' \longrightarrow D$$

But whatever the intermediate conditions, it is clear that after the state A has become resolved, through pressure of external conditions, into the state D, this resolution takes place more readily, occurring at once after state A is reached.

The same law is illustrated in the experiments of Yerkes and Spaulding on association in crabs. In the experiments of Spaulding ('04) with hermit crabs, the introduction of the dark screen into the aquarium, and the diffusion of the juices of the fish, cause the animals to move about. In so doing they reach the dark screen, which induces, let us say, the physiological condition A. This leads to no special reaction. But this is followed regularly by contact with food, inducing the physiological state B, which is concomitant with a positive reaction. The physiological state A is thus regularly resolved into the state B. In the course of time this resolution becomes automatic, so that as soon as the state A is reached, it passes to B. The positive reaction concomitant with B is therefore given even though the original cause of B is absent. The actual number of physiological states which could be dis-

tinguished is of course greater than what we have set forth, but this does not alter the principle involved.

The law which we have just brought out may then be summed up as follows:

*The resolution of one physiological state into another becomes easier and more rapid after it has taken place one or more times.* Hence the behavior primarily characteristic for the second state comes to follow immediately upon the first.

The operations of this law are seen on a vast scale in higher organisms, where they constitute what we commonly call memory, association, habit, and the basis of intelligence. It has been shown to hold in a number of lower organisms, though in these the manifestations of this law are comparatively little known. Yerkes and Spaulding have demonstrated its applicability to Crustacea. The low acelous flatworm *Convoluta* evidently shows it clearly, since as we have seen in the preceding paper, it forms definite habits. It has even been demonstrated, as we have seen, in the protozoa, particularly *Stentor* and *Vorticella*. According to Hodge and Aikins ('95) a method of reacting thus developed lasted in *Vorticella* as long as five hours. In view of these facts, it is probable that the law is a general one and that it will be demonstrated in some form for other lower organisms. There seems to be no theoretical reason for supposing it to be limited to higher animals. The paucity of experiments fitted to test it is amply sufficient to account for the very slight knowledge we have of it in lower organisms.

To return then to the thread of our discussion: In virtue of this law of the readier resolution of physiological states after repetition, the final reaction of a trial series, relieving the organism of the interference with its physiological processes, is later reached more readily than at first, and in time becomes the immediate reaction to the interfering condition. Thus the change of behavior induced by interference of a certain sort has come to be of a perfectly definite character, and all trial movements are omitted.

It is in this second stage of the process, when the relieving response has become set through the law above discussed, that an end or purpose seems to dominate the behavior. This end or purpose of course actually exists, as a subjective state called an idea, in man. Whether any such subjective state exists in the

lower organism that has gone through the process just sketched we of course do not know. But some objective phenomenon, as a transient physiological state, corresponding to the objective physiological accompaniment of the idea in man, would seem to be required in the lower organism. The behavior in this stage is that which, in its higher reaches at least, has been called intelligent.

But so far as the objective occurrences are concerned there would seem to be nothing in even this later stage of behavior involving anything different in principle from what we find in the inorganic world. The only additional feature is this law of the readier attainment of a certain state or action after repetition. We have not attempted to state this law in an entirely adequate manner, but there would seem to be nothing implied by it that is specifically vital, in the sense that it differs in essential principle from what we find in the laws of causality as applied to the inorganic world. It certainly by no means requires in itself the action of any "final cause"—that is, of an entity that is at the same time purpose and cause. On the other hand, it undoubtedly does produce that type of behavior which has given rise to the conception of the purpose acting as cause. This conception is in itself of course a correct one, so far as we mean by a purpose an actual physiological state of the organism, determining behavior in the same manner as other factors determine it.

That regulation takes place in the behavior of many animals in the manner above sketched seems to the writer an established fact, and it appears to be perhaps the only clearly intelligible way in which regulatory behavior could be developed in a given individual.

But we are of course confronted with the fact that many individuals are provided at birth with definitely regulatory methods of reaction to certain stimuli. In these cases the animal is not compelled to go through the process of performing trial movements, with subsequent fixation of the successful movement. How are such cases to be accounted for?

If the regulatory methods of reaction acquired through the process sketched in the preceding paragraphs could be inherited, there would of course be no difficulty in accounting for such congenital regulatory reactions, or habits. It is perhaps not going too far to say that this possibility is not yet out of court, though

opinion at present seems to be generally against it. Yet Semon ('04) in his recent valuable monograph on the phenomena allied to memory and habit, maintains the affirmative view, and presents evidence in favor of it. We are in the beginning of the study of such problems, and it can hardly be said that experiments of sufficient duration and precision have yet been tried to really test the matter. If the inheritance of regulatory reactions acquired after trial should be demonstrated, the process sketched above would give us a satisfactory general method for the development of regulatory behavior, in the race as well as in the individual. In the protozoa this difficulty of course does not exist; the acquirements of individuals may remain as acquirements of the race.

If such inheritance does not occur, then the existence of congenital definite regulatory reactions would seem to be explicable only on the basis of the selection of individuals having varying methods of reaction, unless we are to adopt the theories of vitalism. In the method we have sketched above, a certain reaction that is regulatory is selected, through the operation of physiological laws, from among many performed by the same individual. In what is called natural selection, the same reaction is selected from among many performed by *different* individuals—in both cases because it is regulatory—because it assists the physiological processes of the organism. The two factors must work in the same direction. "Intelligence" and natural selection are two analogous methods of selecting the adaptive reactions from among the possible ones; they must then work together, as Baldwin ('02) has so well pointed out. Which of the two factors is the essential one in producing congenital adaptive reactions we shall of course not attempt to decide, since no one knows.

We often find in organisms behavior that is not regulatory, or that is regulatory only in a very imperfect way. How are we to account for this? Without going into details, it is evident that there exist at least three general conditions that may result in non-regulatory behavior. First, the organism is formed of substance that is subject to the ordinary laws of physics and chemistry. Various physical and chemical agents may act directly upon this substance, producing results that are not regulatory. The fact that the relation of external processes to internal ones is one of the chief determining factors in producing reactions, of

course does not exclude the possibility of the direct action of agents on the body substance. The operation of intense physical and chemical agents may injure or destroy the substance of which the organism is composed, and with it the organism, in spite of any reaction the organism can give. Second, the organism can perform only those movements which its structure permits. Often none of these movements can relieve the existing interference with the physiological processes. Then the organism can only try them, without regulatory results, and die. Examples of this are seen in the behavior of *Paramœcium*, or of *Planaria* when placed in heated water. Both animals perform practically all the reactions of which they are capable, before they succumb. Third, certain responses may become fixed, in the way sketched above, because under usual conditions they relieve the organism. Now if the conditions change, the organism can respond at first only by this fixed reaction, and if this does not relieve, the animal may be destroyed before a new regulatory reaction can be developed. This condition of affairs is widespread among animals.

All together, the regulatory character of behavior as found in many animals seems perhaps intelligible in a perfectly natural, directly causal way, on the basis of the principles brought out above. We may summarize these principles as (1) the selection by varied movements of conditions not interfering with the physiological processes of the organism; (2) the fixation of the movements by which the selected conditions were reached, by the law of the readier resolution of physiological states after repetition. Neither of these principles seem to contain anything specifically vitalistic, or opposed in principle to what we find in the inorganic world.

Is it possible that regulation is based on similar principles in other fields than behavior? Bodily movement is only one of the many kinds of activity that may vary, and variations of any of the organic activities may impede or assist the physiological processes of the organism. Is it possible that interference with the physiological processes may induce changes in other activities—in chemical processes, in growth, and the like—and that one of these activities is selected, as in behavior, through the fact that it relieves the interference that caused the changes?

There is some evidence for this possibility. Let us look for

example at regulative changes in the chemical activity of the organism, such as we see in acclimatization to poisons, in responses to changes in temperature, or in the adaptation of the digestive juices to the food. What is the material from which the regulative changes may be selected? One of the general results of modern physical chemistry is expressed by Ostwald ('02, p. 366) as follows: "In a given chemical structure all processes that are possible, are really taking place, and they lead to the formation of all substances that can occur at all." Some of these processes are taking place so slowly that they escape usual observation; we notice only those that are conspicuous. But in its enzymes the body possesses the means of hastening any of these processes and delaying others, so that the general character of the action shall be determined by the more rapid process. Such enzymes are usually present in the body in inactive forms (zymogens), which may be transformed into active enzymes by slight chemical changes, thus altering fundamentally the course of the chemical processes in the organism.

It is evident that the organism has presented to it, by the condition just sketched, unlimited possibilities for the selection of different chemical processes. The body is a great mass of the most varied chemicals, and in this mass thousands of chemical processes in every direction—all those indeed that are possible—are occurring at all times. There is then no difficulty as to the sufficiency of the material presented for selection, if some means may be found for selecting it. The process which will relieve any unfavorable condition, if any such process is possible, is actually occurring in an infinitesimal way, and needs only to be hastened.

Further, it is known that interference with the physiological processes does result in many changes in the internal activities of the organism, as well as in its external movements. Intense injurious stimulation causes not only "excess" movements of the body as a whole, but induces marked changes in circulation, in respiration, in temperature, in digestive processes, in excretion, and in other ways. Such marked internal changes involve, and indeed are constituted by, alterations of profound character in the chemical processes of the organism. These chemical changes are sometimes demonstrated by the production of new chemical substances under such circumstances. Furthermore, it is clear that the internal changes due to interference with the

physiological processes are not stereotyped in character, but varied. Under violent injurious stimulation respiration may become for a time rapid, then is almost suspended. The heart for a time beats furiously, then feebly, and there is similar variation in other internal symptoms.

Thus it seems clear that interference with the life processes does induce varied activities in other ways than in bodily movements, and that among these are varied chemical processes. There is then presented opportunity for regulation to occur in the same way as in behavior. Certain of the processes occurring relieve the disturbance of the physiological functions. There results then a cessation of the changes. In other words, a certain process or condition is selected through the fact that it does relieve.

There is much evidence that the law of the readier resolution of physiological states after repetition applies to other bodily processes as well as to behavior. The much readier induction of digestive trouble by a small quantity of a certain food, after a large quantity has once induced it is perhaps an example; many better ones are given by Semon ('05). If the analogy with behavior holds in this respect, there will be present at a later period certain fixed methods of chemical response, by which the organism reacts to certain sorts of stimulation—as by the production of a definite antitoxin when a certain poison is introduced. Definite organs or organisms will have left open to them only certain limited possibilities of variation—due to the development of something corresponding to the “action system” in behavior. Thus, in the pancreas there will not exist unlimited possibilities as to the chemical changes that may easily occur. Its “action system” will be limited perhaps to the production of varied quantities of certain enzymes—*amyllopsin*, *trypsin*, etc. The proper selection of these few possibilities will then occur by the general method sketched. When digestion is disturbed by food that is not well digested, variations in the production of the different enzymes will be set in train, and one of these will in time relieve the difficulty, through the more complete digestion of the food. Thereupon the variations will cease, since their cause has disappeared. By still more complete fixation of the chemical response, through the law of the readier resolution of physiological states after repetition, an organ or organism may largely lose its power of varying its chemical behavior, and thus be unable to



meet new conditions in a regulative way. A condition comparable to the establishment of a fixed reflex in behavior will result.

It is perhaps more difficult to apply the method of regulation above set forth to processes of growth and regeneration. Yet there is no logical difficulty in the way. The only question would be that of fact—whether the varied growth processes necessary do primitively occur, under conditions that interfere with the physiological processes. When a wound is made or an organ removed, is the growth process which follows always of a certain stereotyped character, or are there variations? It is, of course, well known that the latter is often the case. In the regeneration of the earthworm, Morgan ('97) finds great variation; he says that in trying many experiments, one finds that what ninety-nine worms cannot do in the way of regeneration, the one hundredth can. The very great variations in the results of operations on eggs and young stages of animals is well known. Removal of an organ is known to produce great disturbance of most of the processes in the organism, and among others, in the process of growth.

It appears then not impossible that in growth processes regulation may be brought about in accordance with the same principles as in behavior. A disturbance of the physiological processes results in varied growth activities. Some of these relieve the disturbance; the variations then cease, and these processes are continued. In any given highly organized animal or plant the different possibilities of growth will have become practically much limited, and it is only from this limited number of possibilities that selections can be made. In some cases, by the fixation of certain processes through the analogue of the law of the readier resolution of physiological states, the organism or a certain part thereof will have lost the power of responding to injury save in one definite way. Under new conditions this one way may not be regulative, yet it may be the only response possible. This may result in the formation under certain conditions of such things as heteromorphic structures—a tail in place of a head, or the like, from a part of the body that is accustomed (in normal development) to produce such an organ. This would again correspond to the production of a fixed reflex action in behavior, even under circumstances where this action is not regulative.

It appears to the writer that the method of form regulation recently developed in a most suggestive paper by Holmes ('04)

is in essential agreement with the general method of regulation here set forth, and may be considered a working out of the details of the way in which growth regulation would probably take place along such lines.

It may be noted that regulation in the manner we have set forth is what, in the behavior of higher organisms, at least, is called intelligence. If the same method of regulation is found in other fields, there is no reason for refusing to compare the action to intelligence. Comparison of the regulatory processes that are shown in internal physiological changes and in regeneration to intelligence seems to be looked upon sometimes as heretical and unscientific. Yet intelligence is a name applied to processes that actually exist in the regulation of movements, and there is, *a priori*, no reason why similar processes should not occur in regulation in other fields. When we analyze regulation objectively, there seems indeed reason to think that the processes are of the same character in behavior as elsewhere. If the term intelligence be reserved for the subjective accompaniments of such regulation, then of course we have no direct knowledge of its existence in any of the fields of regulation outside of the self, and in the self perhaps only in behavior. But in a purely objective consideration there seems no reason to suppose that regulation in behavior (intelligence) is of a fundamentally different character from regulation elsewhere.

It is perhaps hardly necessary to point out the relation of the method of regulation in behavior here discussed to the process of "selection of overproduced movements," so ably set forth in Baldwin's well-known works ('97, '02). The account here given is based on this same process, but differs in a number of points which seem to the writer of fundamental significance for a proper understanding of the method of regulation. Baldwin has likewise made some suggestion as to the possibility of extending this point of view to other fields (Baldwin '02).

We may make a general statement of the features in the method of regulation set forth in this paper, as follows: The organism is primarily activity. It is the seat of many processes, of chemical change, movement, and growth; these are proceeding with a certain amount of energy. These processes depend for their unimpeded course on one another and on the relations to the environment which the processes themselves largely bring about.

When any of the processes are blocked the energy overflows in other directions, producing varied changes in chemical processes, movement and growth. Some of the conditions reached through these changes relieve the interference that was the cause of the changes. Thereupon the changes cease, since their cause has disappeared; the relieving condition is therefore maintained. After repetition of this course of events, the change which leads to relief is reached more directly, as a result of the law of the readier resolution of physiological states after repetition. Thus are produced finally the stereotyped and under certain conditions non-regulatory changes sometimes resulting from stimulation.

This method of regulation is clearly seen in behavior, where its operation is, in the later stages, what is called intelligence. Its application to chemical and form regulation is at present hypothetical, but appears probable.

LITERATURE CITED.

- BALDWIN, J. MARK, '97.—*Mental Development in the Child and in the Race. Methods and Processes.* Second ed., 496 pages. New York.
- '02.—*Development and Evolution.* 395 pages. New York.
- BOHN, G., '05.—*Attractions et Oscillations des animaux marins sous l'influence de la lumière.* Institut Général Psychologique, Mémoires, i, 110 pages.
- ENGELMANN, TH. W., '82.—*Bacterium photometricum. Ein Beitrag zur vergleichenden Physiologie des Licht- und Farbensinnes.* Arch. f. d. ges. Physiol., Bd. xxx, S. 95-124.
- HODGE, C. F., AND AIKINS, H. A., '95.—*The Daily Life of a Protozoan: a Study in Comparative Psycho-physiology.* Amer. Journ. Psychol., vol. vi, pp. 524-533.
- HOLMES, S. J., '04.—*The Problem of Form Regulation.* Arch. f. Entw.-mech., Bd. xviii, S. 265-305.
- JENNINGS, H. S., '02.—*Studies on Reactions to Stimuli in Unicellular Organisms. IX. On the Behavior of Fixed Infusoria (Stentor and Vorticella), with Special Reference to the Modifiability of Protozoan Reactions.* Amer. Journ. Physiol., vol. viii, pp. 23-60.
- '04.—*Physiological States as Determining Factors in the Behavior of Lower Organisms. Contributions to the Study of the Behavior of the Lower Organisms, fifth paper, pp. 109-127.* Carnegie Institution of Washington, Publ. 16.

- MORGAN, T. H., '97.—Regeneration in *Allolobophora foetida*. Arch. f. Entw.-mech., Bd. v, S. 570-586.
- OSTWALD, W., '02.—Vorlesungen über Naturphilosophie. 457 pages. Leipzig.
- SEMON, R., '04.—Die Mneme als erhaltendes Prinzip im Wechsel des organischen Geschehens. 353 pages. Leipzig.
- SPAULDING, E. G., '04.—An Establishment of Association in Hermit Crabs, *Eupagurus longicarpus*. Journ. Comp. Neurol. and Psychol., vol. xiv, pp. 49-61.
- YERKES, R. M., '02.—Habit Formation in the Green Crab, *Carcinus granulatus*. Biol. Bull., vol. iii, pp. 241-244.

# “POLARITY” CONSIDERED AS A PHENOMENON OF GRADATION OF MATERIALS.

BY

T. H. MORGAN.

In my paper<sup>1</sup> entitled “An Attempt to Analyze the Phenomena of ‘Polarity’ in Tubularia” I offered an interpretation of certain experiments carried out by Stevens and myself.<sup>2</sup> In another paper,<sup>3</sup> “An Analysis of the Phenomena of Organic Polarity,” written at about this time the same interpretation was applied to the general question of polarity. These attempts to analyze the problem suggested a number of new experiments in which the conclusions could be tested further, and I shall give in the following pages the results of some new work on Tubularia.

I may recall my hypotheses that the phenomenon of polarity in Tubularia depends on the *graded distribution of materials from the hydranth to the stolon*. This gradation is the basis in which the formative action takes place and produces the new hydranth. The stimulus calling forth the reaction is the presence of a free end.<sup>4</sup> From the previous experiments and from those to be described here the following conclusions may be drawn:

(1) *That a gradation of hydranth-forming substances is present in the stem of Tubularia, and that the amount present at any level determines the rate at which both the oral and the basal hydranth develop.*

(2) *That in addition to the quantitative factor the direction of the gradation or the polarity is a qualitative factor in the result.*

---

<sup>1</sup>Journ. Exp. Zoöl., i, 1905.

<sup>2</sup>Journ. Exp. Zoöl., i, 1905.

<sup>3</sup>Science, xx, Dec., 1904.

<sup>4</sup>Following Driesch I have sometimes stated that the stimulus comes from the action of the sea water on the free end, but it is difficult to distinguish between the action of the sea water and the simple exposure of the free end (an internal factor). Since the normal regeneration of Tubularia takes place in sea water we can not distinguish between these two possibilities. If regeneration could be made to take place in moist air the sea water, as a factor, would be eliminated.

(3) That it is probable that the materials of the oral end set free in the circulation may influence, under certain conditions, the rate of regeneration of the aboral hydranth. The experiments that bear on these questions may now be given under their respective heads.

#### EXPERIMENTS.

##### *The Rate of Development at Different Levels.*

Long pieces of *unbranched* stems were used.<sup>1</sup> In one set the cut was made just below the hydranth; in the second set about the middle of the length of the stem; and in the third set near the base (leaving the piece still so long that the primordium of the hydranth would not be shortened). The long pieces produced their oral hydranths first; those cut through the middle next; and the short pieces last. Driesch obtained similar results.

At the same time experiments were made to determine the rate of development of aboral hydranths at different levels. Long stems were again selected and all tied near the oral end. The aboral ends were then cut off at different levels. Those in which the aboral end was near the ligature developed first; those whose aboral ends were near the middle of the piece developed next; and those whose aboral ends were near the base of the piece developed last. The results show that *the rate of both oral and aboral development is determined by the level at which the end lies*. The most probable interpretation of these facts is that the amount of hydranth-forming substances decreases from the free end to the base, and that their amount determines the rate of regeneration.

##### *Influence of the Direction of the Gradation of the Hydranth-Forming Materials.*

If a stem is tied at its two ends and then cut in two in its middle the cut ends will be at exactly the same level and the neighboring parts are nearly alike. The anterior piece has, in fact, the advantage in the amount of hydranth-forming material near the cut end, although its gradation is in the reverse direction from that at the oral end of the posterior piece. If the direction of the grada-

<sup>1</sup>In all cases where comparisons are made the pieces came from the same colony.

tion is a factor in the rate of development the posterior piece might develop a hydranth at its anterior end before the anterior piece makes a hydranth at its posterior end, despite the slight advantage of the material out of which the aboral hydranth develops. This is, in fact, what occurs, although the difference in rate is not very great and might be overlooked were not a close watch kept on the pieces. Halves of the same piece must of course always be compared rather than different pieces.

An experiment of this kind gave the following results:

Long pieces were tied at the oral and basal ends and were then cut in two in the middle. After twenty-four hours five primordia were present at the oral cut ends of the posterior pieces, and none at the basal cut ends of the anterior pieces. Six hours later the former had primordia in five pieces, the latter in three (but less advanced). After forty-eight hours one of the posterior pieces had produced an oral hydranth, and eight hours later four hydranths were out on these pieces but no aboral hydranths as yet on the anterior pieces. These results show that the hydranth at the oral end of a piece (closed at the basal end) develops a little sooner than does the hydranth at the basal end of a piece (closed at its oral end). This difference can be safely attributed, I think, to the difference in the direction of the gradation of the material near the two cut ends. The results confirm an experiment of King.<sup>1</sup>

*The Probable Influence of the Materials in the Circulating Fluids on the Rate of Development.*

It has been shown by Driesch, Morgan, and Loeb that by closing the oral end of a piece by a ligature the development of the aboral hydranth is greatly hastened; so much so, in fact, that it develops nearly as soon as an oral hydranth at the same level, as described in the last section. What factors cause this acceleration? It is clear that the suppression of the oral hydranth is in some way connected with the result, and it seems not unreasonable to suppose that when the oral hydranth develops it draws on the food supply and thus holds in check the aboral hydranth. The problem is, however, complicated in several ways. In the

<sup>1</sup>Biol. Bull., vi, 1904.

first place the ligature does not in some cases entirely prevent the beginning of the development of the oral end and occasionally I have seen, as Stevens and I have previously observed, that the primordium of the oral hydranth may be laid down. Furthermore, if the material in the circulation is derived mainly from the broken-down ridges, etc., of the oral end it is not clear why a similar breaking down might not also occur at the aboral end and in this way by doubling the total amount present make possible the simultaneous development of both hydranths. Other difficulties are also present that may be spoken of later. In the hope of gaining some further insight into these questions the following experiments were carried out:

The hydranths were removed from a number of pieces, the oral ends of some of these pieces were tied at once (A); others were tied at the end of six (B); or of twelve hours (C). Now during the first six to twelve hours after cutting, the endodermal ridges of the oral ends (in the pieces not yet tied) begin to break down and their material is thrown into the circulation. If the presence of this material in the circulation has any influence on the rate of development of a hydranth (oral or aboral) it might accelerate the aboral development if the oral end is now tied. A number of experiments of this sort show that *the aboral development often takes place sooner in pieces whose oral end is tied after six hours or often even after twelve hours than in check pieces tied at once*. Unfortunately the material began to "go bad" before a sufficient number of results could be obtained to place the conclusion entirely beyond doubt, but there seemed to be evidence in all cases of some acceleration in the development of the aboral hydranth in pieces tied later than in those tied at once, and in most cases the acceleration was so great that the former developed even before the latter. Some of the more satisfactory experiments may now be described.

In the first experiment some pieces were tied at once (A); others after six hours (B). Forty-seven hours later the A-pieces showed nothing, while four of the seven B-pieces had produced primordia. After seventy-two hours two of the A-pieces had primordia, while four of the B-pieces had primordia, one a hydranth, and two nothing.

In another series, in which the B-pieces were tied after fourteen hours, the aboral hydranths of the A-series developed first. The



start of fourteen hours was so great that even the acceleration of the B-pieces did not suffice to make them develop first, and this would hardly be expected since the whole development often occurred in less than forty-eight hours, but the B-pieces were not fourteen hours behind the A-pieces.

In another series tied at once (A); after six hours (B), and after eighteen hours (C), it was found after forty-eight hours that five of the A-pieces barely showed primordia and five others nothing; that four of the B-pieces showed primordia further advanced than the primordia of the A-pieces, and six nothing; that one of the C-pieces showed the barest beginning of a primordium and nine nothing (in poor condition). After seventy-two hours all of the A-pieces had primordia; four of the B-pieces had hydranths and the remaining six primordia; all ten of the C-pieces had *young* primordia.

In an experiment of this kind different pieces are necessarily compared, and, since no two pieces can be assumed to be cut at exactly equivalent levels, it is, perhaps, unsafe to draw conclusions from so small a number of observations. If, as seems to be the case, pieces tied after six hours develop as soon as, or sooner than, those tied at once (*i. e.*, six hours earlier), the result is probably due to the presence of material in the circulation derived from the oral end before tying.

It may be asked, why may not the reserve material of the wall throughout the piece be used rather than that thrown into the circulation by the breaking down of the ridges? If this were the case the total amount of material would be much more than necessary to supply both ends of a long piece at once, as shown by the fact that a long piece cut into shorter ones will produce as many oral hydranths as there are pieces, in the same time that long pieces cut at equivalent levels produce oral hydranths. Therefore if an appeal is made to the amount of food material to explain the acceleration of the aboral hydranth, it must be the material of the circulation postulated rather than that of the wall.

In still another way I have tried to find out what part, if any, of the materials of the circulation influence the rate of development. The hydranths were cut off from a number of pieces and then after six hours (or more) ligatures were tied around the pieces at different levels, in some pieces (A) near the oral ends; in others (B) near the middle; and in others (C) quite near the basal end.

If the rate of development of the aboral hydranths depends, to any extent, on the amount of fluid in the circulation, the A-pieces should develop first, then the B-pieces, and lastly the C-pieces; for the amount of gastro-vascular fluid, with its contained material shut off in the basal end is greater in (A) than in (B), and greater in (B) than in (C). The results show that in most cases the order is that just given.

In the first set tied after six hours, the rate in (A), (B) and (C) seemed to be about the same. In the second set, tied after twelve hours, the (A) and (B) appeared at nearly the same time, but the C-pieces were distinctly delayed.

In the third set, tied after six hours, the A-pieces developed ahead of the (C's). There were no B-pieces.

In the fourth set, tied after six hours, the (A's) developed before the (B's), and the latter sooner than the (C's). (The difference between the (B's) and the (C's) was not marked.)

In the fifth set, tied after six hours, the (A's) averaged better than the (B's), and the (B's) better than the (C's), although the difference was more apparent at first than later.

In the sixth set, tied after six hours, the (A's) began to develop before the (C's). There were no B-pieces. The same difference could be seen throughout the later development.

The results from these experiments all point in the same direction. The nearer the ligature to the basal end, after the oral end had been allowed to develop for six hours, the later the development of the aboral hydranth. Nevertheless without further experiments I feel it unsafe to rely too much on these data, because here also different pieces have to be compared, but if the results are established by further work they indicate that the materials of the circulation are a factor in the rate of aboral development. It should be clearly understood that whether this is true or not the general theory of polarity here proposed is little affected, for the question of the *rate* of aboral development in a piece tied at the oral end has only an indirect bearing on the problem of polarity. Only the rate is affected. The heteromorphosis is due to the totipotency of the stem and the stimulus of the free end.

GENERAL DISCUSSION OF RESULTS.

From the data furnished by these and by previous experiments we may, I think, formulate a statement in regard to the phenomena of polarity in Tubularia. Several factors enter into the result:

(1) The material of the stem is totipotent, and may produce a hydranth at any level, but more quickly at an oral end of a piece than at an aboral end. The quicker response at the oral end is due, on my view, to the gradation of the material in the direction of more to less.

(2) *The gradation is the polarity*, and on this as a basis the formative changes take place. Whether these formative changes involve only known physical elements need not be discussed here, but *whatever the kind of process the gradation gives the basis for its directive action*—the presence of a free end calling forth the formative changes.

(3) The development of the aboral hydranth may appear, on first thought, to contradict this idea of polarity. In reality it does not do so, for the gradation is only one of a number of factors that may possibly determine the result. A stronger influence of another sort may call forth, in the totipotent material, the hydranth-forming action. In fact, all the phenomena of axial heteromorphosis show that the polarity may be overcome; sometimes one condition, sometimes another causing this result. Thus when the totipotence is lost and the material can only produce one kind of structure, if it produces anything, as in the tail of the tadpole, the polar influence—the gradation of the material—is overcome in heteromorphic regeneration from the anterior end and here a tail and not a head develops.

That even in Tubularia there is a conflict between opposing factors when an aboral hydranth forms (in a piece tied at the oral end) is shown by the delay in the development compared with the oral development at the same level of the basal piece.

LOCALIZATION IN EGG AND ADULT AND ITS BEARING ON DEVELOPMENT AND REGENERATION.

A number of recent results in experimental embryology indicate that the protoplasm of the egg is composed of a number of materials—quantitatively or qualitatively different—that go to different parts of the embryo, and become later the basis of the parts

of the body. That the *early development* depends on the protoplasm, and not on the nucleus, as previous theories had assumed, was first demonstrated by Driesch and myself by means of an experiment on the unsegmented ctenophore-egg, from which a part of the protoplasm was removed but the entire nucleus left. Defects appeared in the embryo. Later observers have confirmed the conclusions that we drew from our experiment and have greatly extended the results. The observations of Wilson and of Conklin have been especially interesting in showing that extensive processes of protoplasmic migration may occur. Furthermore the results of Wilson and of Yatsu have shown that the localization of the materials takes place only after the germinal nucleus of the egg breaks down. Even in such eggs as the sea urchin there is evidence of a similar localization.<sup>1</sup> Although in this egg and in some other eggs the totipotence of the different regions often so overbalances the difference of the parts that isolated portions of the egg do not show strikingly the evidence of the specification of their materials.

Since the different regions of the adult animal are formed out of the different materials of the egg, which must be assumed to increase enormously in volume as the animal grows larger, we must suppose that these different materials furnish the basis for the regeneration of the same organs. In many animals the gradation in the amount of each kind of substance may be very gradual and extend throughout almost the entire length of the body, *e. g.*, in *Lumbriculus*, as shown in that a head or a tail may regenerate from any level. If on the other hand sharp regional differences exist, such as that between a leg and the body of an animal, we may expect to find a corresponding limitation in the regenerative capacity, so that the leg is no longer capable of making a body, etc.

Even where the material is proliferated at the cut surface to make the new part, as happens in many cases of regeneration, the gradation of the material of the old part still maintains—that first produced coming from the more distal end and that produced later coming from further in, from the more proximal parts—but the formative action must be supposed to take place not only under the influence of the new material, but of the neighboring parts as well.

---

<sup>1</sup>Driesch ('00); Boveri ('01); Morgan ('01).

It must be assumed, of course, that while some materials grade off from head to tail others grade off from tail to head, etc. Thus in *Lumbriculus*, the head-end material grades from the anterior end backward, while the tail-forming materials decrease from behind forward. There must often be regions of considerable overlapping of these materials as shown again in *Lumbriculus* and *Tubularia* and less so in *Lumbricus*. Furthermore certain regions may consist so largely, or even exclusively, of certain kinds of substances that despite the postulated polar gradation these regions are capable of regenerating only one kind of structure. Thus as I have shown in the posterior regions of the earthworm, and in the tail of the tadpole, only one kind of structure, *e. g.*, tail, can develop. I have tried also to show that the heteromorphosis of very short cross-pieces of Planarians finds its best explanation on the assumption that by the partial removal of the polar influences in such short pieces, this influence no longer dominates the development, and the centripetal influences determine that a new head will develop—the head-forming substances being in excess. In other Planarians the tail-forming substances seem to be dominant in certain parts and a heteromorphic tail develops at the anterior end when the polar influence is lessened.

The most striking example of the influence of the gradation of the material on the formative action is shown by lateral pieces of Planarians. If cross-pieces are first cut from the anterior, middle, and posterior regions of a Planarian, and if the sides are then cut from these pieces, so that none of the median organs are left, it will be found that the position of the pharynx in the new worms that regenerate will depend on the region of the original worm from which the pieces were cut. In the new worms from lateral pieces from the anterior part of the original worm the pharynx lies near the posterior end, in the worms from the middle pieces the new pharynx lies in the middle of the length; and in the worms from posterior pieces the new pharynx lies nearer the anterior end of the new worm. Thus, although in all these pieces having the same shape (and open at both ends) the possibility would seem to exist for the pharynx to lie in the same place in the new worm, in reality its position is different, and appears to be determined by the *gradation* of the material. Thus in the anterior pieces there is more of the pharynx material in the part of the piece nearer to the old pharynx, *i. e.*, at the posterior end.

In the middle pieces its amount is greatest at the middle. In the posterior pieces the amount is greatest nearer the anterior end.

These relations throw more light on the problem of localization in regeneration than any others that I know of, and the conclusions to be drawn from them are so obvious that they can scarcely fail to carry conviction.

The reader may probably have observed that in the preceding attempt to account for the phenomena of polarity I have referred to the protoplasm in the sense of cytoplasm rather than nucleus. Yet on the current view of embryologists every nucleus contains the sum total of all the hereditary qualities and may transfer, in some unknown way, these qualities to the protoplasm. Every part, therefore, is looked upon as potentially totipotent, and its only limitations are those due to its protoplasmic differentiation. Even this is supposed to be capable of being worked over under the influence of the nucleus so that it may at times return to its "embryonic condition" of indifference and may then under the influence of the nucleus again be differentiated in new ways. If this belief represents the actual conditions in the tissues then the remarkable limitations of regenerative power in some instances can only be explained by assuming that the protoplasm when once differentiated can in these cases no longer return to the so-called "embryonic condition." It is not apparent, if this be the case, why nuclei should always be present in somatic cells unless they have some other important function to perform than that of transmitters of hereditary qualities. There is, of course, much evidence to show that the nuclei have important physiological functions to perform, *viz.*, in connection with the metabolism of the cell. This admission at once raises the question as to whether the main function of the nucleus may not be connected with metabolism and have nothing to do with hereditary transmission, unless indirectly.

If we inquire on what evidence the accepted view rests that the nucleus is the transmitter of the hereditary qualities we shall find the evidence not entirely conclusive. The principal argument in favor of this doctrine is that the spermatozoön brings into the egg only, or mainly, the nucleus of the male germ-cell, and thus the paternal qualities must become transmitted to the offspring by means of the nucleus. It is pertinent to ask what becomes of the cytoplasm of the male germ-cell? Is the nucleus simply

ejected from the cell, leaving the cytoplasm behind? Assuredly not! A small part of the cytoplasm goes into the tail of the spermatozoön, and since, in some cases, the tail is said not to enter the egg that part of the cytoplasm is lost. The rest of the cytoplasm—by far the largest amount in many cases<sup>1</sup>—concentrates around the nucleus, enters the egg with it, and, no doubt, mingles with the cytoplasm of the egg. It is a matter of common observation that the chromatin of the nucleus must also greatly contract to be stowed away in the minute sperm-head. If we compare the size of the nucleus of the sperm mother-cell with the size of the head of the spermatozoön the enormous difference in volume between the two becomes apparent. It is true that most of the volume of the nucleus consists of nuclear sap rather than chromatin, but there can be no doubt that the chromatin itself may expand and shrink within very wide limits. Have we not laid too much emphasis on the nucleus of the sperm-head because we can trace its history with great clearness, and have we not ignored the cytoplasm that is carried in, because becoming at once commingled with that of the egg it is lost to sight? May it not be true that the paternal cytoplasm becomes incorporated in the fertilized egg as a part of the cytoplasm and as it increases in volume comes to play its part in the differentiation of the cell. The accumulation of cytoplasm around the male-nucleus<sup>2</sup> which accompanies the latter as it moves toward the female nucleus, its division and its distribution to the daughter-cells suggests how the mechanism of transmission may be accomplished. From this point of view the protoplasm and not the nucleus might transmit the hereditary qualities of the male as well as of the female. The nucleus would be concerned with the metabolism of the cell. The more difficult question still remains, of course, as to how far the metabolic influence of the nucleus might influence the cytoplasm and affect its hereditary properties, but a discussion of this possibility in the absence of data would be too speculative to be profitable.

In conclusion we find that the localization in the cytoplasm of the egg is directly comparable to the localization of the materials of the adult animal. The “polarity” in both cases is an expression of the gradation in the material. The phenomena of regeneration

---

<sup>1</sup>Its more watery parts are thrown off.

<sup>2</sup>Generally supposed to come mainly from the egg, but which may also *in part* come from the sperm.

are, in part, the outcome of this gradation; in part also of the kind of substances in a given region and also of a formative action using the preceding conditions as a basis, as well as taking into account the amount of material present. The formative influence acting in a centripetal direction always gives precedence, as it were, to the terminal organs. In regard to the specification of the cytoplasm, as the basis of regeneration, *versus* the assumed totipotency of the nuclei, we have at present a choice of three views, no one of which can be said to be satisfactorily established: (1) The cytoplasm alone furnishes the basis for the action of the formative changes without regard to whether the nuclei are storehouses of hereditary qualities or whether they have to do only with the feeding (and respiration?) of the cell—not *directly* with its growth and specification. (2) The nuclei are reserve storehouses of all of the hereditary elements and may be called upon to supply whatever is needed for the formation of the new part, the cytoplasm returning to an "embryonic condition" to be worked over under nuclear control. This view is the logical outcome, it seems to me, of the current view in regard to the relation of nucleus and cytoplasm. I have tried to show by a brief examination of the evidence on which this view rests that it is not established beyond doubt. (3) Both nuclei and cytoplasm may be progressively specialized, hence it may not be profitable to make any distinction between the part they play in regeneration. The gradation of the material—the polarity—is, on this view, expressed as much by one as by the other, and by both alike.



## STUDIES ON CHROMOSOMES. .

### II. THE PAIRED MICROCHROMOSOMES, IDIOCHROMOSOMES AND HETEROTROPIC CHROMOSOMES IN HEMIPTERA.<sup>1</sup>

BY

EDMUND B. WILSON.

WITH 4 FIGURES.

In investigating the physiological significance of the chromosomes and their individual values in heredity, it is important to determine as accurately as possible how far they are differentiated in respect to individual behavior, and to ascertain by the comparative study of different forms to what extent the chromosomes can be grouped in well-defined classes. The work of Henking, Paulmier, Montgomery, Gross and Stevens on the Hemiptera has shown that this group is peculiarly favorable for such a study; and I believe from my own observation that no group of animals has thus far been examined that offers greater advantages in this direction.<sup>2</sup> But although the general results obtained by the above-mentioned observers are of great value and interest they nevertheless show many discordances of detail that stand in the way of a consistent general interpretation of the phenomena, while some of Gross's conclusions are a stumbling block in the way of the whole theory of the individuality of the chromosomes. For this reason I propose in this paper to record a series of observations that I hope may serve to clear away some of the confusion that now exists in the accounts of the subject, and that open the way, I believe, to a true interpretation of the "accessory chromosome" and its relation to the determination of sex.

In a series of suggestive papers ('01, '04, '05) Montgomery

---

<sup>1</sup>Attention is called to the Appendix in which are briefly recorded facts, determined by later observations, that exactly realize the theoretic expectation regarding the sexual differences of the chromosome-groups, stated at p. 539. An abstract of these observations was published in the issue of *Science* for Oct. 20, 1905.

<sup>2</sup>I am much indebted to Mr. Uhler's kindness in identifying many of the species examined.

has endeavored to bring together under the name of "heterochromosomes" two classes of chromosomes in these insects, namely, the "unpaired heterochromosome" ("accessory chromosome" of McClung)<sup>1</sup> and the "paired heterochromosomes" (or "chromatin nucleoli"), which differ markedly in behavior from the other chromosomes during the maturation process. Montgomery gives as the most essential characteristic of these chromosomes "their difference in behavior from the other chromosomes in the growth period of the spermatocytes and oocytes, as sometimes during the rest period of the spermatogonia, a difference which appears usually to consist in the maintenance of their compact structure and deep-staining intensity, so that while the other chromosomes become long loops or even compose a reticulum, these do not undergo any such changes or only to slight extent" ('05, p. 191). "Thanks to this peculiarity they can be followed with extreme certainty from generation to generation, even during rest stages; and so are splendid evidence for the thesis of the individuality of the chromosomes" ('04, p. 146).

The study of these chromosomes has led Montgomery to some very important conclusions regarding synapsis and reduction with which, as far as their more general features are concerned, I am glad to find my own results in substantial agreement. Considered more in detail, however, there are many points regarding which I think Montgomery's general treatment of the "heterochromosomes" requires emendation.

In a preceding paper (Wilson, '05) the fact was indicated that two types of "paired heterochromosomes" or "chromatin nucleoli" occur in Hemiptera. The first, including what I have called the

---

<sup>1</sup>Since there is no reason for considering the "accessory chromosome" as in any sense accessory to the others, it appears to me that McClung's term might well be abandoned in favor of a less compromising one. I suggest that until their physiological significance is positively determined chromosomes of this type may provisionally be called *heterotropic* chromosomes (in allusion to the fact that they pass to one pole only of the spindle in one of the maturation-divisions) in contradistinction to *amphitropic* chromosomes, the products of which pass to both poles in both divisions. There are several objections to this term, one of which is that the "accessory" chromosome behaves as a heterotropic body in only one of the divisions (and probably in one sex only). Another is the fact that the members ("chromatids") of every chromosome-pair are heterotropic in the reducing division, since this only separates univalent chromosomes that were previously in synapsis; but if, as in these studies, the term "chromosome" be consistently applied to each coherent chromatin-element of the equatorial plate, whatever be its valence or mode of origin, this objection is perhaps not serious enough to weigh against the convenience of the term.

“idiochromosomes” (which occur in such forms as *Lygæus*, *Euschistus*, *Cœnus*, *Brochymena*, etc.) are typically unequal in size, and differ from all other known forms of chromosomes in the fact that their union in synapsis gives rise to an unequal or asymmetrical bivalent. The spermatogonial groups correspondingly show but one small chromosome, since the larger idiochromosome is not noticeably smaller than the ordinary chromosomes. The second type includes the equal paired “chromatin nucleoli” of such forms as *Anasa*, *Alydus*, *Syromastes* or *Archimerus*. Since the latter are almost always markedly smaller than the others they may conveniently be called the paired microchromosomes, or better, in order to avoid all ambiguity, simply the *m*-chromosomes; and these are distinguishable in the spermatogonial groups as an equal pair of especially small chromosomes. The most obvious difference of behavior between these two types, so far as is now known, is that the idiochromosomes divide as separate univalents in the first maturation-mitosis, which accordingly always shows one more than half the spermatogonial number of separate chromatin elements, while the *m*-chromosomes, like the other chromosomes, always unite to form a bivalent before the first mitosis—which therefore shows the same number as in the second division. Other no less characteristic differences are described beyond. These two forms are not yet known to coexist in the same species; and, as a rule, forms that possess the idiochromosomes do not have an “accessory” or heterotropic chromosome, while as far as now known such a chromosome is always associated with the *m*-chromosomes.

The confusion that has grown out of the failure to observe these differences arose in the first instance from two conclusions—both of which I shall show to be untenable—reached by Paulmier in his valuable, and, as far as the general history of the maturation-process is concerned, very accurate, study of the spermatogenesis of *Anasa tristis* ('99), and was increased by the subsequent efforts of Montgomery ('01, '04, '05) to reduce the behavior of the “chromatin nucleoli” to a uniform scheme. Paulmier, who was the first to reëxamine the history of the “accessory” chromosome since its discovery by Henking, was also the first to describe the *m*-chromosomes (in *Anasa*) as two very small chromosomes of equal size in the spermatogonial metaphase-groups. These two

small chromosomes, he believed, united in synapsis to form a single condensed bivalent chromosome-nucleolus which persisted throughout the growth-period of the spermatocytes and later gave rise to the small central "tetrad" of the first maturation-mitosis. He believed, further, that after an equal division of this small "tetrad" in the first mitosis each of its products passed undivided to one pole of the second spermatocyte-spindle. He therefore compared the "small tetrad" (microchromosome-bivalent) of *Anasa* to the body, first discovered by Henking in *Pyrrochoris*, and afterward found in the Orthoptera and some other insects by McClung and others, to which the last-named author gave the name of "accessory chromosome." In identifying the chromosome-nucleolus of the growth-period as the microchromosome-bivalent Paulmier has been followed by Montgomery in all of his papers and with some modifications by Gross ('04) in his recent study of *Syromastes*. Paulmier's conclusion on this point cannot, however, be sustained, as I shall try to show; and the same is true of his identification of the microchromosome-bivalent as the "accessory" or heterotropic chromosome.

#### I. GENERAL HISTORY OF THE *M*-CHROMOSOMES AND THE HETERO-TROPIC CHROMOSOME DURING THE GROWTH-PERIOD AND IN THE MATURATION-DIVISIONS.

The behavior of the *m*-chromosomes in the maturation-divisions may conveniently be considered first.

Paulmier's original preparations,<sup>1</sup> as well as my own more recent ones, give demonstrative evidence of the equal division of the small central chromosome in both maturation-mitoses, and the same appears no less clearly in *Alydus* and in *Archimerus*, precisely as has been shown by Montgomery ('01) in *Protenor* and by Gross ('04) in *Syromastes*. I was long since led to suspect an error in Paulmier's conclusion in regard to this point from the fact, which clearly appears in his own figures, that the "accessory" is nearly or quite as large as the other chromosomes, and much larger than the products of the first division of the small bivalent.

---

<sup>1</sup>I have in the previous paper acknowledged my indebtedness to Dr. Paulmier's generosity in placing at my disposal his entire series of preparations of *Anasa* and other insects. He has since added to this indebtedness by sending me from time to time a large amount of valuable living material.

(Cf. Paulmier's Figs. 28, 34-36, and my Fig. 2, *k-n*.) Both in *Anasa* and in *Alydus* careful search among longitudinal sections of the second division shows in fact in the clearest manner, that the "small dyad" divides into equal halves, so that each of the spermatids received one of its products (Figs. 1, *i-m*; 2, *m, n*). The heterotropic chromosome is a much larger body, as shown by the figures, in *Anasa* fully equal in size to some of the larger single chromosomes of the anaphases of the second division. Paulmier's failure to observe the second division of the small bivalent is easily explained by the difficulty of observing this body owing to its usually central or subcentral position, and the mistake was a very natural one at the time his paper was written. Had he examined *Alydus* where there are but seven chromosomes, which show marked and constant size-differences, he could not have failed to observe this division.

We have now to examine a second and more difficult point, namely, the nature of the condensed nucleolus-like body (chromosome-nucleolus) of the growth-period, which so closely simulates the heterotropic chromosome of the Orthoptera at the corresponding period. I have always doubted Paulmier's and Montgomery's conclusion that this body is the microchromosome-bivalent, from the fact, clearly shown in the figures of both these authors, that the chromosome-nucleolus of the synaptic and growth-periods is always larger, and in some species very much larger (*e. g.*, in *Alydus*)<sup>1</sup> than the two spermatogonial microchromosomes taken together, or than the small central bivalent to which it was assumed to give rise. (Cf. Paulmier's Figs. 16-21, with 26, 28.) This fact did not escape Montgomery's attention, but he explained it as due to an increase of volume on the part of the chromatin-nucleolus in the early growth-period and a corresponding decrease in the late growth-period or in the pro-phases of the first division ('01, p. 203). This explanation was, however, not supported by any sufficient evidence;<sup>2</sup> and the only detailed evidence on this point has been brought forward by Gross ('04) in the case of *Syromastes*. This observer, however, while apparently confirming Paulmier and Montgomery as to

---

<sup>1</sup>Cf. Montgomery, '01, Figs. 96-98.

<sup>2</sup>Montgomery's study of the facts in *Euschistus* ('98) is not in point, since he was here undoubtedly dealing with the idiochromosomes and not with the *m*-chromosomes.

the fate of the chromosome-nucleolus, differs entirely from them in regard to its origin, concluding that it is derived from two of the *larger* spermatogonial chromosomes. In the attempt to reconcile these contradictory results (with both of which my own are in disagreement) he is led to some speculative conclusions that I think must be regarded as highly improbable.<sup>1</sup>

A careful study of all the intermediate stages, not only in *Anasa*, but also in *Alydus*, *Archimerus*, and *Chariesterus* gives in point of fact, evidence that I believe is quite decisive, that *the small central bivalent is not derived from the large chromosome-nucleolus of the growth-period, and that the latter is nothing other than the accessory or heterotropic chromosome*, precisely as in the Orthoptera. To the differences between the idiochromosomes and the *m*-chromosomes already stated may therefore be added the fact that the former, like the heterotropic chromosome, may form a single chromosome-nucleolus during the growth-period, while this is not the case, in the forms I have studied, with the *m*-chromosomes. It may seem strange that Montgomery, after accurately tracing the history of the heterotropic chromosome ("chromosome *x*") in *Protenor* and showing its complete independence of the "chromatin-nucleoli" (*m*-chromosomes) was not led to suspect a similar relation in the other forms. That he apparently did not do so was doubtless due to his having failed to distinguish between the *m*-chromosomes and the idiochromosomes, which latter bodies he correctly identified (in *Euschistus*, etc.) as the bivalent chromosome-nucleolus (or two separate univalents) of the growth-period.

The entire independence of the large chromosome-nucleolus and the *m*-chromosomes is most obvious in *Alydus* and *Archimerus*, partly because in both these forms the heterotropic chromosome is at every period recognizable by its characteristic size, partly because—in *Alydus* certainly, and I believe also in *Archimerus*—the *m*-chromosomes frequently assume a compact condensed form at a much earlier period than in *Anasa*; they can therefore be recognized *in addition to the heterotropic chromosome*, throughout the latter part of the growth-period, at a time when the larger chromosomes are still in the pale, vague condition characteristic of so many of the Hemiptera at this period.

In *Alydus pilosulus* the first mitosis invariably shows seven

---

<sup>1</sup>Gross ('04) pp. 481, 482.

bivalent chromosomes, which show very marked and characteristic size-differences (Fig. 1, *c-g, b*). There are always (1) a largest chromosome or macrochromosome, which is frequently quadripartite; (2) a second largest; (3) three slightly smaller ones of nearly equal size; (4) a fourth, considerably smaller than the last; and finally (5) the smallest or microchromosome-bivalent. These show a characteristic grouping, the five larger ones forming an irregular ring with the small bivalent ("chromatin nucleolus") at its center, while the next smallest lies more or less at one side of the ring (Fig. 1, *g*). In the first division all these chromosomes are equally halved (Fig. 1, *f*). In the second all are again halved with the exception of the second smallest which passes undivided to one pole of the spindle (Fig. 1, *i-o*). The size-relations leave not the least doubt that this chromosome is derived from the one of corresponding size in the first division—*i. e.*, the odd or eccentric one—and the latter accordingly is to be identified as the "accessory" or heterotropic chromosome. In the first division this chromosome sometimes shows a quadripartite form (as was described by Paulmier in *Anasa*) sometimes a dumbbell-shaped or dyad-like form. In the second it is usually unconstricted and often curved (Fig. 1, *i, m, n*), sometimes into a U-shape so as almost to appear double (Fig. 1, *o*).

A study of the growth-period shows that the heterotropic chromosome may be traced uninterruptedly backward from the metaphase of the first division to the contraction-phase of the synaptic period, being always in the form of a condensed chromosome-nucleolus, which in the early growth-period is attached to a large, pale plasmosome, from which it afterwards separates. It is impossible to mistake this chromosome, owing to the fact that its characteristic size does not noticeably change except that it becomes *slightly* larger as the growth-period advances (probably owing to the presence of a central cavity), again becoming slightly smaller as the general condensation takes place. (*Cf.* Fig. 1, *a-c*.) In the contraction-phase (Fig. 1, *a*) and in the early post-synaptic spireme the *m*-chromosomes are not visible, but as the larger chromosomes assume the peculiar pale, ragged, clumped condition, characteristic of the middle and late growth-periods, the *m*-chromosomes frequently come into view, in the form of two compact, intensely-staining bodies, that may occupy any relative position (Fig. 1, *b*). The period at which these bodies

## FIGURE 1.

*Alydus pilosulus*.—*a*, Contraction-phase of synaptic period, “accessory” (*h*) in the form of a condensed chromosome-nucleolus attached to a large plasmosome (*p*); *b*, spermatocyte-nucleus, middle growth-period, showing large diffused chromosomes—“accessory” still attached to the plasmosome—and the two condensed *m*-chromosomes on opposite sides of the nucleus; *c*, early prophase of first division, showing all of the chromosomes, the larger ones condensing; *d*, late prophase, showing “accessory” (*h*) and the two *m*-chromosomes still separate; *e*, slightly later prophase, showing all of the chromosomes; *f*, initial anaphase, first division, the *m*-chromosomes separating; *g*, polar view of metaphase-group, first division; *h*, polar view of metaphase-figure, second division; *i*, *j*, initial anaphases, second division; *k*, spermatogonial metaphase-group; *l*, *m*, *n*, *o*, anaphases of second division.





FIGURE 1.<sup>1</sup>

<sup>1</sup>The figures are all drawn to the same scale as those of the preceding study.

condense into the compact form appears to vary considerably, for they cannot always be distinguished until the later growth-period, and it should be noted that during the pale period the nuclei often show a variable number of smaller deeply-staining granules. I believe, however, that there can be no doubt as to the nature of the two larger bodies on account of their great constancy, their size, and the completeness of the series that connects the earlier with the later conditions (such as is shown in Fig. 1, *c*), where no doubt of their nature can exist. The persistence of the larger chromosome-nucleolus ("accessory") throughout all these stages without any considerable change renders it manifestly impossible that it should give rise to the *m*-chromosome bivalent, either directly as assumed by Paulmier and Montgomery, or by division into two univalents that subsequently conjugate, as described by Gross in *Syromastes*.

In the early prophases the larger chromosomes resume their staining capacity and condense into characteristic cross-forms (Fig. 1, *c*), and finally into compact quadripartite tetrads or bipartite bodies. At this time the heterotropic chromosome assumes a dumbbell or quadripartite shape, and the *m*-chromosomes, which are still quite separate and may even lie on opposite sides of the nucleus, also frequently become bipartite. The nucleus now contains, accordingly, eight separate chromatin-elements, one more than the number of bivalents in the first mitosis, as is also the case in *Archimerus* and *Anasa*, as described beyond. As the spindle forms the two microchromosomes lose their bipartite shape, approach each other, and in the stage just preceding the metaphase finally conjugate to form the small bivalent chromosome at the center of the group. Without fusing, the two halves are then immediately separated, the division always taking place more rapidly than in the case of the larger chromosomes (Fig. 1, *f*).

It is clear to demonstration accordingly, that in *Alydus* the small central bivalent does not arise from the large chromosome-nucleolus of the growth-period, but is formed by the late conjugation of two separate microchromosomes that have no genetic connection with that body. The same fact is shown no less clearly in *Archimerus calcarator* (which shows eight chromosomes in the first mitosis), where the *m*-chromosomes, and the corresponding bivalent, are of extraordinary minuteness and are so much smaller than the accessory that they could not possibly be confused with the latter (Fig. 3).

I believe that in this form, too, the *m*-chromosomes are frequently recognizable as condensed separate bodies in the growth-period; but owing to their minute size it is difficult to be sure of this. In any case, in the period just before the disappearance of the nuclear membrane they are quite distinct from the "accessory," which is, as in *Alydus*, immediately recognizable by its size (Fig. 3, *g*). From this period, as in *Alydus*, the latter body may be traced continuously backward into the growth-period.

The foregoing facts, observed in *Alydus* and *Archimerus* are in close agreement with Montgomery's results on *Protenor*, differing only in that the condensation of the *m*-chromosomes takes place somewhat later.<sup>1</sup> In *Anasa* the condensation of these chromosomes from the diffused condition takes place still later; and this, combined with the fact that the "accessory" cannot be certainly distinguished from the other larger chromosomes by its size, renders the question more difficult of solution than in *Alydus*, though I believe the result is equally decisive. In *Anasa*, as in *Alydus* or *Archimerus*, the small central bivalent of the first equatorial plate is formed by a very late conjugation of two separate microchromosomes that only come together as the spindle forms, precisely as Gross describes in *Syromastes*. Of this fact no doubt is left by the study of a large number of preparations that show every stage of the process, step by step. In the late prophases, just before the nuclear membrane disappears, the nuclei invariably show twelve separate, condensed, intensely-staining chromatin-elements (one more than the number of chromosomes in the first mitosis) in addition to one or more pale rounded plasmosomes with which the chromosomes cannot for a moment be confused. Ten of these are larger bivalents which have the form of quadripartite tetrads or dumbbell-shaped bodies. The remaining two are much smaller bodies, irregularly ovoidal or frequently more or less distinctly bipartite (*m*, Fig. 2, *e*, *f*); they may occupy any relative position. As the spindle forms, the microchromosomes lose their bipartite form, assume an evenly rounded ovoidal shape, and conjugate at the center of the equatorial plate to form a small dyad-shaped bivalent (Fig. 2, *g-i*). Without fusion the two halves are then immediately drawn apart

---

<sup>1</sup>In *Alydus pilosulus* this author believed the *m*-chromosomes, as usual, to be derived from the large chromosome-nucleolus.

FIGURE 2.

*Anasa tristis*.—*a*, Contraction-phase of synaptic period, showing “accessory” (*h*) and plasmosome (*p*); *b*, spermatocyte-nucleus, late growth-period, beginning of the condensation, showing “accessory” (*h*) and the *m*-chromosomes (*m*); *c*, a slightly later stage than the last; *d*, later stage, immediately before the final condensation, from a long-extracted preparation; *e*, *f*, two sections of one nucleus, showing all of the twelve chromosomes immediately before the disappearance of the nuclear membrane; *g*, view of one pole of the late prophase just after disappearance of the nuclear membrane, the *m*-chromosomes still wide apart; *h*, early metaphase-group in side view, showing approach of the *m*-chromosomes; *i*, four chromosomes from the metaphase, conjugation of the *m*-chromosomes to form the small central bivalent; *j*, early anaphase, separation of the *m*-chromosomes, “accessory” at the left; *k*, polar view of metaphase-group, first division; *l*, polar view of metaphase-group, second division; *m*, *n*, anaphases of second division, showing division of *m*-chromosomes and the undivided heterotropic chromosome; *o*, *p*, spermatogonial metaphase-groups drawn as carefully as possible to show sizes of the chromosomes.

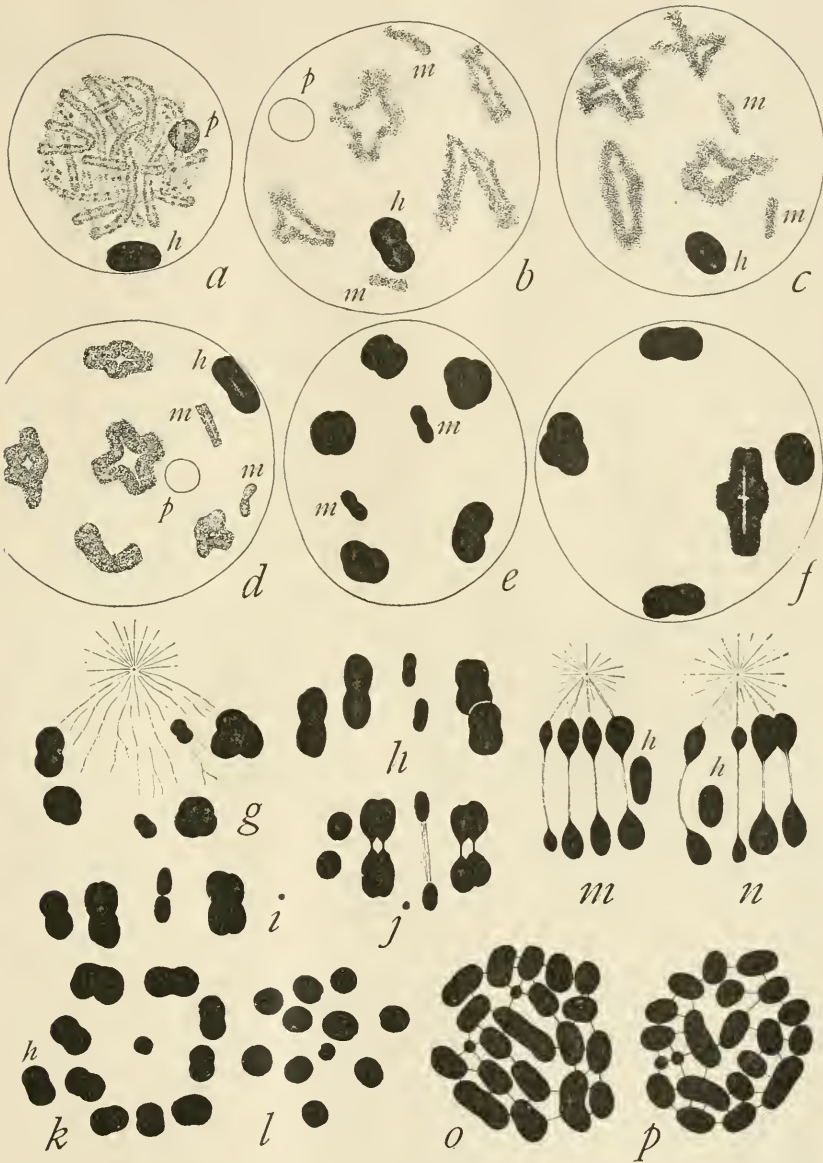

FIGURE 2.

in the initial anaphase, always separating in advance of the larger chromosome-halves (Fig. 2, *j*). It is not possible in the prophases just described to identify the heterotropic chromosome; but from the analogy of *Alydus*, *Syromastes* and *Archimerus* it may be assumed with great probability that it is the "odd or eccentric chromosome which in the metaphase-group lies outside the principal ring (Fig. 2, *k*).

During the growth-period, as Paulmier described, the chromosomes, with the exception of the single conspicuous chromosome-nucleolus, remain in a loose, diffused, lightly-staining condition from the post-synaptic spireme stage until the condensation of the tetrads begins; and until the end of this period the *m*-chromosomes cannot be distinguished. Throughout this whole period the chromosome-nucleolus is distinctly visible; and it may at every period, even in hematoxylin preparations, if long extracted, be at once distinguished from the true nucleolus or plasmosome (as is shown in Paulmier's figures), since the former stains intensely black, the latter pale blue or in double-stained preparations, pale red or yellow. In the contraction-phase of the synaptic period it is more or less elongated, ovoidal, or sometimes slightly constricted in the middle (Fig. 2, *a*). In the late post-synaptic period, at a time when the other chromosomes are beginning to shorten and to give rise to the characteristic double cross-figures and V-figures it is usually more or less elongated, the transverse constriction is less obvious or disappears from view, and the body often shows faintly but distinctly a longitudinal split. (Cf. Paulmier, Fig. 22.) Slightly later, as the other chromosomes continue to shorten and thicken, the chromosome-nucleolus also shortens and thickens, often assuming a spheroidal form in which a central cavity may sometimes be seen. As the remaining chromosomes condense to form the tetrads it again alters its shape, often becoming bipartite (Fig. 2, *b-d*), but sometimes showing a more or less distinctly quadripartite form as described by Paulmier (*e. g.*, in his Figs. 23, 24). It now becomes indistinguishable from the other larger chromosomes, since the latter have also condensed into similar tetrads or dyad-like forms, but the two *m*-chromosomes are immediately recognizable by their small size. It might therefore be supposed that the chromosome-nucleolus has divided to form the two microchromosomes, as Gross believed to be the case in *Syromastes*. The stage that immediately precedes this gives,

however, conclusive evidence that such is not the case. In this stage (corresponding to Paulmier's Figs. 22, 23) the chromosome-nucleolus is still unmistakably recognizable by its compact and rounded appearance, while the other chromosomes, including the two microchromosomes are still in the form of paler and more diffuse bodies. The *m*-chromosomes at this period (one of them is clearly shown in Paulmier's Fig. 24) appear as short, more or less ragged, paler, irregular rods that give the appearance of being longitudinally split (Fig. 2, *b-d*). Some of the cysts at this period show every stage in the condensation of these two small diffused chromosomes to form the two small, dyad-like microchromosomes that conjugate to form the small central bivalent. I have studied numerous nuclei in these stages with great care, and believe that they remove every doubt that the two microchromosomes that conjugate to form the small central bivalent in *Anasa* arise neither from separate small condensed bodies, as in *Protenor* or often in *Alydus*, nor from the single large chromosome-nucleolus as assumed by Paulmier, Montgomery and Gross, but from diffused masses similar to the larger ordinary chromosomes during the greater part of the growth-period. The same fact may be seen in *Chariesterus*, though I have not in this case so complete a series of stages. The chromosome-nucleolus must therefore give rise to one of the larger chromosomes; and the exact agreement of *Anasa* with *Alydus* and *Archimerus*, save in the one point of the later condensation of the microchromosomes in the former form, justifies the confident conclusion that in *Anasa* the chromosome-nucleolus is the "accessory" or heterotropic chromosome. *Anasa*, *Alydus*, *Chariesterus*, and *Archimerus* thus fall in line with the facts observed in the Orthoptera, and I believe the same will prove to be the case with other Hemiptera in which an "odd," "accessory" or heterotropic chromosome occurs.<sup>1</sup> This result, which is wholly at variance with the accounts of previous observers, forms the first step in clearing away the confusion that has hitherto stood in the way of a consistent general interpretation of the heterotropic chromosome.

---

<sup>1</sup>I cannot at present offer a definite explanation of the divergence between this result and that reached by Gross in *Syromastes*. Without questioning the accuracy of his figures, I feel confident, in view of what I have seen in so many other forms, that further examination of this genus will give a different result, both on this point and on a number of others.

## 2. RELATION OF THE CHROMOSOME-NUCLEOLUS TO THE SPERMATOGONIAL CHROMOSOMES.

In view of the foregoing conclusion it will readily be admitted that a derivation of the chromosome-nucleolus from the two spermatogonial microchromosomes is *a priori* highly improbable; and in point of fact, all the actual observations not only of myself, but also, I believe, of Paulmier and Montgomery, are opposed to such a conclusion.

This question has been complicated in a most unfortunate way by errors in counting the spermatogonial chromosomes. It was natural that the earlier observers should have expected to find an even number of chromosomes in the spermatogonial divisions; and the number is in point of fact an even one in all the forms that possess the idiochromosomes, as I have shown in the first of these studies. Regarding the forms that possess an accessory or heterotropic chromosome the existing accounts are, however, in conflict in giving sometimes an even number (*Anasa*, *t.* Paulmier and Montgomery, *Syromastes*, *t.* Gross, *Alydus pilosulus*, *t.* Montgomery), and sometimes an odd one (*Protenor*, *Harmostes*, *Ædancala*, *Alydus eurinus*, *t.* Montgomery). A similar difference occurs in the existing accounts of the spermatogonia in Orthoptera, some of which are described as showing an even number and some an odd. This contradiction has enormously increased the complication of the subject; for it has necessarily involved the view that in cases showing an even number the heterotropic chromosome is a bivalent body, formed by the synapsis of two of the spermatogonial chromosomes; and this, in turn, very naturally led Montgomery ('04, '05, etc.) to the further conclusion that in cases showing an odd number one of the chromosomes (presumably the "accessory") is already bivalent in the spermatogonia.

I myself had at first no doubt of the correctness of both these interpretations, and my faith was not shaken even after the discovery that the number is 13 in *Alydus pilosulus* (Fig. 1, *k*), 15 in *Archimerus* (Fig. 3, *i*), and 21 in "*Chariesterus*."<sup>1</sup> When, however, demonstrative evidence was obtained that even in *Anasa*—in opposition to the concordant results of Paulmier and Montgomery on *Anasa* and those of Gross on the related form *Syro-*

<sup>1</sup>The identification of this form (from Paulmier's material) is doubtful.



mastes—the number is 21 instead of 22 (Fig. 2, *o*, *p*) I confess that surprise at this result was followed by skepticism regarding all of the accounts asserting the occurrence of an even number in other forms. This result, which was totally unexpected to me, rests on the study of a large number of division-figures exactly in the metaphase, many of which are of almost schematic clearness. Of these, twenty-five (selected from six testes from different individuals, including both adults and larval forms) were drawn with the camera, chromosome by chromosome, and subsequently counted. Without one exception these drawings show exactly twenty-one chromosomes; it is therefore out of the question that my result (worked out on Paulmier's original preparations) can be due to an accidental displacement of one of the chromosomes in the process of sectioning, or to other similar sources of error. I believe the error of previous observers on this point is owing to the fact that one or more of the chromosomes sometimes show a more or less obvious constriction near the middle, and the larger ones are not infrequently curved—sometimes almost into a U-shape—so that one might readily be mistaken for two.

Quite in harmony with this result is the fact that in *Anasa* the metaphase groups always show not two but three chromosomes that are distinctly larger than the others,<sup>1</sup> one of these being obviously without a mate of like size, while all the others may be symmetrically paired, two by two, as a study of Fig. 2, *o*, *p*, will show. It is obvious therefore that the heterotropic chromosome, and hence the chromosome-nucleolus of the growth-period, must be compared with one, not two, of the spermatogonial chromosomes.

In *Alydus* the heterotropic chromosome appears in the contraction phase of the synaptic period as an ovoidal single body, always attached to one side of a large plasmosome and immediately distinguishable from the latter by its different staining-reaction (Fig. 1, *a*). Comparison of this figure with that of the spermatogonial chromosomes (Fig. 1, *k*), shows that the heterotropic chromosome at this period is much larger than the two spermatogonial microchromosomes united. In the spermatogonial equatorial plates of *Alydus* or *Archimerus* it is not possible

---

<sup>1</sup>I regret to find myself here again in disagreement with Montgomery, who finds only two large spermatogonial chromosomes in *Anasa* ('04, p. 151, Fig. 16).

positively to identify the heterotropic chromosome by its size; though it is evidently not one of the largest ones, since the latter form a symmetrical pair (Fig. 1, *k*) which doubtless unite to form the single macrochromosome of the spermatocyte-divisions (in accordance with Montgomery's account of several other forms). In *Anasa*, however, it may be regarded as highly probable that the heterotropic chromosome is one of the largest three chromosomes, the remaining two of which pair as usual to form the spermatocyte macrochromosome-bivalent (Fig. 2, *o*, *p*). This is confirmed by comparison with the chromosome-nucleolus at the synaptic contraction-period (Fig. 2, *a*). At this time it varies considerably in form, but is always more or less elongate, often ovoidal, sometimes almost rod-shaped, and sometimes more or less distinctly constricted in the middle; it rarely appears to be composed of two symmetrical halves (described by Gross as the typical condition in *Syromastes*.) It is rarely attached to a plasmosome, the latter body, when present, being usually separate (as in Fig. 2, *a*).

The discrepancy in size between the chromosome-nucleolus and the spermatogonial microchromosomes is here still greater than in *Alydus*. On the other hand, as a comparison of the figures will show, the chromosome-nucleolus of this period is of very nearly the same volume as one of the largest three spermatogonial chromosomes. All the facts therefore point to the conclusion that one of the latter is the heterotropic chromosome, and that it persists throughout the growth-period as the chromosome-nucleolus, precisely as in *Alydus* or *Protenor*. Exactly the same result is indicated in *Archimerus*, where the discrepancy in size between *m*-chromosomes and heterotropic chromosome is even greater than in *Anasa* (Fig. 3, *a*, *i*).

### 3. BEHAVIOR OF THE HETEROTROPIC CHROMOSOME IN THE MATURATION-DIVISIONS OF ARCHIMERUS CALCARATOR.

In all the Hemiptera thus far described (*Pyrrochoris*, *Anasa*, *Alydus*, *Protenor*, *Syromastes*, *Harmostes*, *Cedancala*, *Charies-terus*), the heterotropic chromosome, when present, divides equally in the first spermatocyte-mitosis, but fails to divide in the second, thus showing a marked contrast to the phenomena in the Orthoptera where the reverse order occurs. In the present section I wish

briefly to record the fact that Archimerus, which agrees so closely with Alydus in most other respects, differs from this and all the above-mentioned forms in that the heterotropic chromosome fails

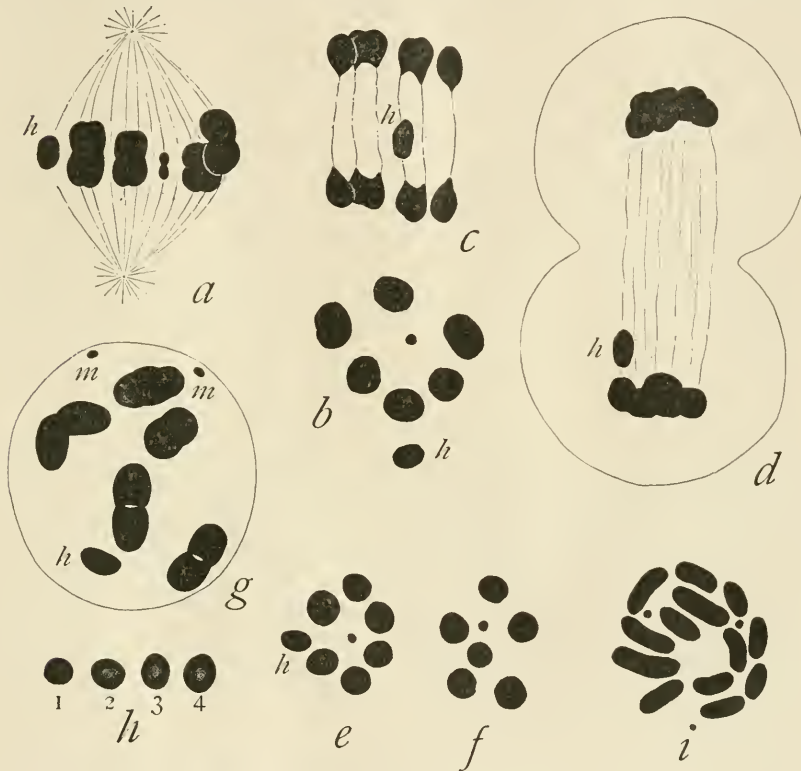

FIGURE 3.

*Archimerus calcarator*.—*a*, Side-view of first division metaphase showing heterotropic chromosome and *m*-chromosome bivalent; *b*, polar view of metaphase-group, first division; *c*, anaphase group, first division, side view; *d*, late anaphase, first division; *e*, *f*, polar views of metaphase-groups, second division, the former including, the latter lacking, the heterotropic chromosome; *g*, spermatocytenucleus, prophase of first division, showing heterotropic chromosome (*h*), the two separate *m*-chromosomes (*m*), and five of the six large bivalents; *h*, views of the chromosome-nucleolus (heterotropic chromosome) at different periods—1, from the contraction-phase of the synaptic period; 2, middle growth-period; 3, 4, later growth-period (the last three showing central cavity); *i*, spermatogonial metaphase-group.

to divide in the first mitosis, passing over bodily to one pole and dividing equally in the second mitosis, precisely as in the Orthoptera (Fig. 3, *c*, *d*). This fact, which at first I myself hardly found

credible, is placed beyond doubt by numerous preparations showing every stage in the first division, and no less certainly by the occurrence of two forms of the second division, in equal numbers and appearing side by side in the same cyst, one of which shows seven chromosomes, the other eight, the additional chromosome in the latter case being usually recognizable by its size. Fig. 3, *c, d*, shows two stages in the history of the heterotropic chromosome in the first division. Fig. 3, *e, f*, gives polar views of the two forms of equatorial plates in the second division, one showing seven, the other eight, chromosomes. A large number of sections from different individuals show no exception to this mode of distribution, the two divisions being immediately distinguishable by the size of the cells and by both the size and the form of the chromosomes. A similar case will be described, in *Banasa calva*, in the following section.

#### 4. THE CHROMOSOME-GROUP IN *BANASA CALVA*.

In this section I shall briefly describe a remarkable form that is unique among the Hemiptera thus far described in that it possesses both the idiochromosomes and a heterotropic chromosome; and as a consequence of this it is *unique among all described animals in possessing not merely two but four visibly different classes of spermatid-nuclei in equal numbers*. These four classes are in no visible way distinguishable in the fully formed spermatozoa, but are clearly apparent in the chromosome-groups of the spermatid-nuclei.

No spermatogonial metaphase-groups are shown with sufficient clearness to admit of an accurate count, but there are great numbers of dividing spermatocytes which show every stage of both the maturation-divisions. The first division constantly shows, in polar view of the metaphase, fifteen chromosomes, of which two are markedly smaller than the others (Fig. 4, *a, b*). As is demonstrated by their later history, one of these smaller chromosomes is the small idiochromosome (*i*) and one the heterotropic chromosome (*b*). One of them frequently, but not invariably, lies at one side of the group, sometimes outside the principal ring of chromosomes (Fig. 4, *a*); but it may lie inside the ring (Fig. 1, *b*). One always lies within the ring; and judging by the analogy of such forms as *Lygæus*, *Euschistus* or *Cænus*, a

much larger chromosome beside which it lies is to be identified as the larger idiochromosome. Besides these fifteen undoubted chromosomes one or more paler rounded bodies are often present, lying outside the chromosome-group, sometimes close to it, that are undoubtedly the remains of the plasmosome of the growth-period.

In side views of the metaphase-figure all of these chromosomes, with one exception, have a symmetrical bipartite (rarely a quadripartite) shape; and in the ensuing division these are equally divided. One of the small chromosomes (heterotropic) never shows a bipartite shape, but is simply elongate and more or less fusiform (Fig. 4, *c*, *d*, *e*). As the division proceeds, this chromosome at first remains near the equator of the spindle and then passes over bodily toward one pole where it enters the daughter group (Fig. 4, *f*, *g*), finally shortening again so as to assume a spheroidal form. One of the secondary spermatocytes therefore receives fifteen chromosomes, the other fourteen.

The failure of this small chromosome to divide in the first mitosis at first seemed to me so anomalous (I had not then observed the similar phenomenon in *Archimerus*, described in the foregoing section) that for a time I thought that this body must be one of the fragments of the plasmosome; and this suspicion was strengthened by the fact that other plasmosome-fragments are often found lying near or in the spindle (Fig. 4, *g*). Further study, however, conclusively showed that this suspicion was not well-founded. The plasmosome-fragments are always rounded, paler, wholly inconstant in position and never lie in the equatorial plate. The heterotropic chromosome, on the other hand, is always present (many division-figures in all stages have been studied) and every stage of its asymmetrical distribution has been repeatedly observed. All doubt is, moreover, removed by a study of the metaphase-figures of the second division. Great numbers of these, showing the relations with schematic clearness, are available for study. In polar view these show either fourteen or thirteen chromosomes (Fig. 4, *b*, *i*), the two classes existing in approximately equal numbers, and side by side in the same cyst. At first sight neither of the small chromosomes of the first division can be distinguished in the polar view of the second. This is owing to two causes: First, the small heterotropic chromosome, having failed to divide while all the others are but half as large as before,

is sometimes hardly distinguishable from the latter—though, as in Fig. 4, *i*, it can often be identified on careful scrutiny. Second, the small idiochromosome, now only half as large as in the first division, has conjugated in typical fashion with the larger one, so as to be visible, as a rule, only in side view (Fig. 4, *j*), though careful focusing will often reveal it also in polar view, especially when the idiochromosome-dyad lies in a slightly oblique position. In this way the idiochromosome-dyad has been positively identified in Fig. 4, *b, i*. In side-view the second division shows with entire clearness the separation of the idiochromosome-dyad into its two unequal constituents, precisely as in *Lygæus*, *Euschistus*, etc., while all the other dyads, including the small heterotropic, divide equally (Fig. 4, *j-l*). From this it follows that four visibly different classes of spermatid chromosome-groups are formed in equal numbers. Two primary classes are formed that possess respectively fourteen and thirteen chromosomes, according to the presence or absence of the heterotropic chromosome; and each of these falls into two secondary classes, one of which contains the large idiochromosome, the other the small. Although this result necessarily follows from the mode of division, it is not a matter merely of inference, but of observed fact; for with a little pains spindles of both classes in the anaphases may readily be found in a vertical position that show both the sister-groups. Such a pair, from the early anaphase of a fourteen-chromosome spermatocyte, are shown in Fig. 4, *m*, the two groups exactly corresponding, chromosome by chromosome, except in case of the idiochromosomes (which are shown by focusing to be more widely separated than the others). A similar pair from a somewhat later anaphase of the thirteen-chromosome class is shown in Fig. 4, *o*, the relations being as before save that the heterotropic chromosome is lacking. A pair from a later anaphase of the fourteen-chromosome type is shown in Fig. 4, *n*, showing a principal ring of ten ordinary chromosomes within which lie four others. Two of these (below) are ordinary chromosomes; the other two are, at one pole the heterotropic and the small idiochromosome, at the other pole the heterotropic and the large idiochromosome.

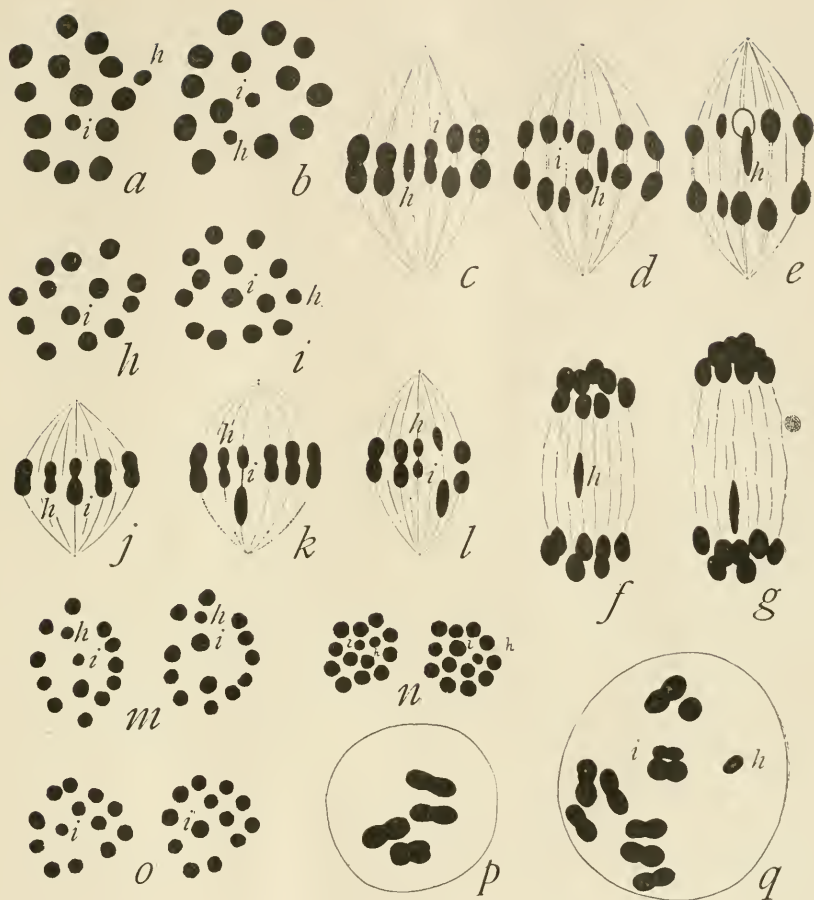

FIGURE 4.

*Banasa calva*.—*a, b*, Metaphase-figures, first division, in polar view, showing fifteen chromosomes, including two small ones (*h*, heterotropic chromosome, *i*, small idiochromosome—the large idiochromosome not distinguishable); *c-g*, successive stages of first division, in side-view, showing division of the small idiochromosome (*i*), and the unipolar movement of the heterotropic chromosome (*h*); *h*, metaphase-group of second division, with thirteen chromosomes; *i*, metaphase-group of the same division with fourteen chromosomes; *j-l*, metaphase and early anaphase of second division, showing separation of the idiochromosomes, and equal division of the heterotropic chromosome; *m*, sister-groups from the same spindle, early anaphase second division, fourteen-chromosome type; *n*, similar pair, late anaphase; *o*, similar pair, middle anaphase, thirteen-chromosome type; *p, q*, entire chromosome-group from a single nucleus at the end of the growth-period, showing idiochromosome-dyad (*i*) and heterotropic chromosome (*h*).

The four classes thus formed may be tabulated as follows:

Primary Class A	}	(1)	12 ordinary chromosomes, 1 heterotropic, 1 large chromosome.
		(2)	12 ordinary chromosomes, 1 heterotropic, 1 small idiochromosome.
Primary Class B	}	(3)	12 ordinary chromosomes, 1 large idiochromosome.
		(4)	12 ordinary chromosomes, 1 small idiochromosome.

Restating the facts from the point of view of mere size, it appears that class (3) contains no especially small chromosome, class (2) two small chromosomes, and classes (1) and (4) each one small chromosome, the latter being in one case the heterotropic, in the other the small, idiochromosome.<sup>1</sup>

I have not yet studied in sufficient detail the history of this form in the growth-period, which will require additional material; but the main facts are such as might be expected. In the middle growth-period the nuclei show, with great constancy, two unequal chromosome-nucleoli, both of which frequently appear hollow. The larger of these is almost certainly the idiochromosome-bivalent; for in the prophases of the first division it may be seen separating into its two unequal constituents, precisely as I described in *Brochymena* (Fig. 4, *p, q*). At this period the heterotropic chromosome is unmistakably recognizable by its size and shape, showing no constriction like that of the other chromosomes. I believe this to be identical with the smaller chromosome-nucleolus of the earlier period, but cannot offer decisive proof.

#### CRITICAL AND COMPARATIVE.

The three well-defined classes of chromosomes that have been described in this and my preceding paper differ from the others, each in its own way, especially in respect to their behavior in the process of synapsis and during the growth-period. The most characteristic common feature of the first two classes is their long delayed synapsis, which in both cases is deferred to the period

<sup>1</sup>It is probable that additional light will be thrown on this form by further study of the related one, *Thyanta custator*, which I now have under investigation. The general aspect of the chromosome group in this species is closely similar to that of *Banasa*, and the first mitosis also shows fifteen chromosomes, of which however three, instead of two, are smaller than the others. The second mitosis differs from that of *Banasa* in showing always but thirteen chromosomes, and I have not thus far found a heterotropic chromosome in either division. Though I cannot yet speak positively, these conditions seem only explicable under the assumption that two pairs of idiochromosomes are present. From such a condition one nearly similar to that observed in *Banasa* might readily be derived by the disappearance of one of the small idiochromosomes.



immediately preceding the reduction-division—*i. e.*, in case of the *m*-chromosomes to the prophases of the first division, at the very end of the growth-period, and in case of the idiochromosomes to a still later period following the first division (though a temporary or preliminary union frequently occurs at a much earlier period). The “accessory” or heterotropic chromosome, finally, does not undergo synapsis at all, since it is without a mate with which to pair.

As regards their behavior in the growth-period, the idiochromosomes and the heterotropic chromosome agree in being “heterochromosomes” in Montgomery’s sense—*i. e.*, are distinguished from the other chromosomes by their compact form and deep-staining capacity. The *m*-chromosomes, on the other hand, may remain in a diffused condition throughout the early and middle growth-periods, only condensing to the compact form at the same time as the ordinary chromosomes (*Anasa*, “*Chariesterus*”); their condensation may, however, take place in the middle growth-period (*Alydus*), or even earlier (*Protenor*, according to Montgomery). An analogous difference in the time of condensation exists in case of the idiochromosomes, which in case of *Lygæus* do not condense as early as in *Cænus* or *Euschistus*.

My observations prove definitely in some cases (*Alydus*, *Anasa*, *Archimerus*, “*Chariesterus*”), and I think render it probable for all cases, that in those Hemiptera that possess an “accessory” or heterotropic chromosome and two equal spermatogonial microchromosomes (*m*-chromosomes), the large chromosome-nucleolus of the synaptic and growth-periods is not, as other observers have supposed, the microchromosome-bivalent (“chromatin nucleolus” of Montgomery) but the heterotropic chromosome, precisely as in the Orthoptera. This error of identification has led Montgomery to designate three quite distinct kinds of chromosomes by the same name of “chromatin-nucleoli.” These are (1) the equal paired spermatogonial microchromosomes and the corresponding bivalent of the first spermatocyte division; (2) the idiochromosomes, which are typically unequal and do not form a bivalent in the first division; and (3) the heterotropic chromosome as it appears in the growth-period. It is therefore desirable, despite some repetition, to bring together in brief form the principal distinctions between these three.

1. The paired microchromosomes—or preferably “*m*-chromosomes,” since forms may be found in which they are not smaller than the others—form an equal pair in the spermatogonia, and in most of the forms thus far known are much smaller than the others. These do not, ordinarily conjugate to form a bivalent in the general synaptic period, and may (*Alydus*, *Archimerus*) or may not (*Anasa*, “*Chariesterus*”) condense early in the growth-period to form two small separate chromosome-nucleoli which can be distinguished in addition to the principal one (heterotropic chromosome). They undergo a very late synapsis (in the prophases of the first maturation division) to form a small symmetrical bivalent, typically central in position, that undergoes a reduction-division in the first mitosis and an equation-division in the second. Each spermatid nucleus therefore receives a single *m*-chromosome. They are always, as far as known, associated with a heterotropic chromosome, and the number of spermatogonial chromosomes is odd (with the more than doubtful exception of *Syromastes*). The first maturation-division shows a number of chromosomes which when doubled is one more than the spermatogonial number (as in *Orthoptera*). Known to occur in *Anasa*, “*Chariesterus*,” *Syromastes*, *Protenor*, *Alydus*, *Archimerus*, *Harmostes*, *Ædancala*, and doubtless occur in many others.

2. The idiochromosomes are typically unequal in size (*Nezara* forms an exception) forming an unequal pair in the spermatogonia (which accordingly show typically but one small chromosome); they may conjugate to form a bivalent at the time of general synapsis, or may remain separate, in either case condensing to form a chromosome-nucleolus (or two separate unequal ones) which persists throughout the greater part or the whole of the growth-period. In either case they are in the Hemiptera always separate univalents at the time of the first maturation-mitosis, and separately undergo an equation-division in that mitosis. This division accordingly shows one more than half the spermatogonial number of separate chromatin-elements, the latter number being in all cases an even one. At the end of the first mitosis their products conjugate to form a bivalent dyad (thus reducing the number of separate chromatin-elements to one-half the spermatogonial number). This dyad, typically unsymmetrical, undergoes a reduction-division in the second mitosis, and all of the spermatozoa receive the same number of chromosomes,

one-half receiving the larger and one-half the smaller idiochromosome. They are not ordinarily associated with a heterotropic chromosome, the single known exception being *Banasa*. The idiochromosomes are known to occur in *Lygæus*, *Cænus*, *Podisus*, *Trichopepla*, *Mineus*, *Nezara*, *Murgantia*, *Brochymena* and *Banasa* and are doubtless of much wider occurrence.

3. The "accessory" or heterotropic chromosome is certainly in most Hemiptera—and I believe will be found to be in all—unpaired in the spermatogonia, and its behavior is throughout that of a univalent body. It fails to unite in synapsis with any other chromosome, and persists throughout the spermatocytic growth-period as a chromosome-nucleolus. During the earlier part of this period it resembles the idiochromosome bivalent (or the univalent large idiochromosome) in being attached to a large plasmosome from which it afterward separates.<sup>1</sup> This chromosome divides in only one of the maturation-divisions, passing undivided to one pole of the spindle in the other. The latter division is usually the second (*Pyrrochoris*, *Anasa*, *Protenor*, *Alydus*, *Chariesterus*, *Syromastes*, *Harmostes*, *Ædancala*), but in *Archimerus* and *Banasa* it is the first. In either case one-half the spermatozoa receive one more chromosome than the other half.

From the foregoing it will be seen that Montgomery correctly identified the chromosome-nucleolus in the growth-period of such forms as *Euschistus*, *Cænus*, *Podisus*, *Brochymena*, *Trichopepla* or *Nezara*, which possess the idiochromosomes. He was, however, at fault in the conclusion that it gave rise to a small bivalent in the first division, the small chromosome of this division being always a univalent that is not at this time paired with its (usually) larger fellow; and further, owing to a failure to discriminate between these bodies and the paired microchromosomes of the *Anasa* or *Alydus* type, he describes and figures the spermatogonial groups in most of these forms as containing a symmetrical pair of "chromatin-nucleoli." Owing to his having overlooked the constant separateness of the idiochromosomes as univalents in the first mitosis he has also, I believe, been misled in several

---

<sup>1</sup>It is doubtless a similar condition that has led Moore and Robinson ('05) in the case of *Periplaneta*, to conclude that the "accessory" chromosome is nothing but a "nucleolus." These observers have evidently studied the phenomena in a very superficial manner.

instances in regard to the spermatogonial number (*e. g.*, in *Euschistus variolarius*, *Nezara* and *Brochymena*). The statement given in the general summing up of his latest paper ('05) "Whenever the heterochromosomes occur in pairs in the spermatogonia they (*i. e.*, the 'chromatin nucleoli') always conjugate to form bivalent ones in the first spermatocytes, and their univalent components become separated in the first maturation mitosis, *i. e.*, divide prereductively" (p. 195, and elsewhere), is inapplicable to the idiochromosomes; for even though they conjugate to form a bivalent chromosome-nucleolus in the growth-period they again separate to divide as separate univalents in the first mitosis, as I showed in detail in *Brochymena*, and as must also occur in the other forms (as is proved by the number of the chromosomes and their later history). The statement cited above applies only to the *m*-chromosomes of such forms as *Anasa*, *Chariesterus*, *Alydus*, *Archimerus* or *Protenor*; but the name "chromatin nucleoli" is in these cases not very appropriate in view of the fact that in the very form (*Anasa*) in which they were first discovered they do not appear as chromatin-nucleoli at any time during the growth-period of the spermatocytes. As to their behavior in the rest-period of the spermatogonia I have at present no opinion to express. It is further probable that the distinction urged by Montgomery between the "odd chromosome" and the accessory ('05, p. 192) is also not valid; for my observations prove that in *Alydus* and *Archimerus* the "odd chromosome" ("accessory") is a typical chromosome-nucleolus (*i. e.*, "heterochromosome") in the growth-period, and it is extremely probable that the same will be found to hold true of the "odd chromosome" of *Harmostes* and *Cedancala*. I think therefore that Montgomery's general conclusions regarding the "heterochromosomes" require some revision.

We may now briefly consider the nature of the "accessory" or heterotropic chromosome. So long as any of the forms possessing such a chromosome were supposed to have an even number of spermatogonial chromosomes the conclusion drawn by Montgomery ('01, '04, '05) that this chromosome is a bivalent seemed an almost necessary one, even in cases where it appears as a single body in the spermatogonia. The observations brought forward in this paper cast grave doubt, I think, on all of the earlier accounts asserting an even spermatogonial number in

the Hemiptera that possess a heterotropic chromosome. Of these accounts (in cases positively known to have such a chromosome) there are but four, namely, Henking's original account of *Pyrochoris* ('90), Paulmier's ('99), and Montgomery's ('01, '04) accounts of *Anasa*, Montgomery's of *Alydus pilosulus* ('01) and Gross's more recent one of *Syromastes* ('04). Henking states that he counted but four cases, one of which seemed to show twenty-three, the other three twenty-four, and it is evident both from the figures and from the frank statement of this able observer, that he adopted the latter number more on account of theoretical considerations than as a result of any adequate study of the facts. I have shown the counts of Paulmier and Montgomery to be erroneous in the case of *Anasa*, and also that of Montgomery in the case of *Alydus pilosulus*. There remains therefore the single case of *Syromastes*; but perhaps, in view of the results I have reached in other forms, I may be allowed the prediction that a reëxamination of this one will lead to a similar conclusion.

If this expectation is verified every ground will be removed for considering the heterotropic chromosome as a bivalent body; and I think that until definite evidence to the contrary is forthcoming we are bound to take this chromosome at its face-value, so to speak, as univalent. This conclusion involves a series of other conclusions and possibilities of which I shall here undertake to indicate only the more important.

1. As was indicated by McClung ('02, p. 71), if the "accessory" be univalent, its behavior in the maturation-mitoses at once falls into line with that of the other spermatogonial chromosomes; for each of these, too, undergoes but one division in the course of the two maturation-mitoses. One of these divisions (the reduction division) merely separates the univalent chromosomes that have previously paired in synapsis (as is so convincingly shown in case of the idiochromosomes or the *m*-chromosomes); and only the fact that the "accessory" has no mate with which to pair renders its behavior in one of the divisions apparently different from that of the ones that do pair.

2. The objections that I myself urged to the suggestion made in the first of these studies regarding the origin of the heterotropic chromosome are thus set aside, and my attempt to compare the idiochromosomes with the *m*-chromosomes was made on incorrect

premises. My suggestion was that a heterotropic chromosome might arise from a symmetrical bivalent by the gradual reduction and final disappearance of one member of the conjugating pair, conditions corresponding to several of the stages of such a reduction being shown to exist in *Nezara*, *Mineus*, *Cœnus*, *Euschistus*, *Murgantia*, and *Lygæus*. All of the facts seem to me to indicate that this interpretation is the true one. Were the small idiochromosome to disappear in such forms as *Lygæus* or *Euschistus*, the large idiochromosome would be left as a heterotropic chromosome agreeing, point by point, with that of such forms as *Alydus*, *Protenor* or *Anasa*, namely, in its persistence as a chromosome-nucleolus during the growth-period; its association with the plasmosome in the earlier part of this period and its subsequent separation from it; its equal bipartition by an equational-division in the first spermatocyte-mitosis, and the failure of the resulting products to divide in the second mitosis; and in correlation with the foregoing the existence of an odd number of spermatogonial chromosomes. The exactness of this correspondence is such, I think, as to lend a high degree of probability to the interpretation.

The only apparent obstacle in its way is the fact that in *Banasa* a heterotropic chromosome coexists with a typical pair of idiochromosomes; but this difficulty only exists under the assumption that a heterotropic chromosome has arisen but once in the history of the species, and nothing is known to justify such an assumption. I think, on the contrary, that the facts in *Banasa* may fairly be taken as evidence that a process is here in progress which if continued would lead to the formation of a second heterotropic chromosome.<sup>1</sup>

3. The formation of a heterotropic chromosome in the manner indicated involves a reduction of the total number of chromosomes by one; and it is possible that this may represent one process by which changes from a higher to a lower number of chromosomes have been brought about. But I doubt whether such a process can have gone very far, since, as pointed out beyond, there is reason to believe that it has occurred in only one sex.

---

<sup>1</sup>Should my surmise (stated in the footnote at p. 530) be correct that in the related form *Thyanta* two pairs of idiochromosomes are present without a heterotropic chromosome, I think additional support will be lent to the above interpretation.

It seems, on the other hand, probable that the *m*-chromosomes may be of more general significance in this direction, since the facts distinctly suggest that they are diminishing or disappearing, and perhaps in some cases already vestigial, structures in both sexes. Paulmier was the first, as far as I am aware, to suggest that a reduction in the size of particular chromosomes might foreshadow their total disappearance; that chromosomes might in this way assume a vestigial character; and further, that such chromosomes might represent "somatic characters which belonged to the species in former times, but which characters are disappearing" ('99, p. 261). This conception was applied by him to the small *m*-chromosomes (which he believed to represent the "accessory"), but was further supported by his observation of a very small chromatin-body that may divide like a chromosome (Paulmier, Fig. 28, *a*) but is only rarely visible.<sup>1</sup> Paulmier's suggestion, which I suspect may prove to embody one of the most important results of his paper, has been further developed by Montgomery. This author first suggested that an uneven number of chromosomes "represents a transition stage between a higher number and a lower" ('01, p. 215); and he has more recently assumed that the "unpaired heterochromosomes" ("accessory" or heterotropic chromosomes) have arisen from paired heterochromosomes ("chromatin nucleoli") or ordinary chromosomes by fusion of the members of a pair to form a bivalent body ('05, p. 197). Both the paired and the unpaired heterochromosomes are considered to be chromosomes on the way to disappearance. Though my conclusion regarding the origin of the unpaired or heterotropic chromosome is an entirely different one, it agrees with that of Montgomery in assuming a reduction in the original number of chromosomes; and it is possible that by a subsequent disappearance of the heterotropic chromosome a further reduction may take place, though as indicated above there are difficulties in the way of this assumption. My conclusion is, however, distinctly opposed to the view that heterotropic chromosomes have arisen from "paired heterochromosomes" (*m*-chromosomes), and although they have some features in common the evidence is opposed to

---

<sup>1</sup>It seems quite possible that this body may be the last remnant of a small idiochromosome, of which the corresponding larger one has remained as the heterotropic chromosome; but definite evidence of this is lacking.

any direct relationship between these two classes of chromosomes. Montgomery has called attention to the fact that the *m*-chromosomes vary greatly in size in different species, graduating down to excessively minute forms (such as those occurring in *Archimerus*.) It is evident that these chromosomes have undergone a symmetrical reduction which, if continued, might lead to the disappearance of both; and such a process, if repeated, would lead in the history of a species to a progressive and parallel reduction of the number in both sexes. When these facts are compared with those presented by the idiochromosomes the thought can hardly be avoided that the reduction of the *m*-chromosomes may be correlated with a corresponding change that is taking place equally in both sexes; while the reduction of the small idiochromosome may represent a change that is taking place more rapidly in one sex than in the other, or affects one sex only.

4. How the foregoing conclusions and suggestions regarding the idiochromosomes and heterotropic chromosomes will square with McClung's hypothesis ('02, 2) and my own similar suggestion ('05) that these bodies may be in some way concerned with sex-determination, does not yet clearly appear from the known data; but there are some considerations that are too interesting in this connection to be ignored. If the heterotropic chromosome be a univalent body the conclusion is unavoidable (since the spermatogonial number is odd) that in the production of males, the number of chromosomes contributed by the two germ-cells cannot be the same. To this extent the facts harmonize with the view of McClung; but further consideration gives reason to doubt some of the more specific features of his hypothesis. The presence of the heterotropic chromosome in the male by no means proves that it is of paternal origin in fertilization, still less that it is specifically the male sex-determinant—indeed, I believe the facts point in the opposite direction. In *Anasa*, for example, where the spermatozoa possess either ten or eleven chromosomes, offspring (males) having twenty-one would be produced by the fertilization of an egg having ten chromosomes by a spermatozoön having eleven (as McClung would assume); but the same result would follow from the fertilization of an egg having eleven by a spermatozoön having ten. I believe the second of these alternatives to be the more probable one for the following reasons: According to my view, the heterotropic



chromosome has assumed its unpaired character by the reduction and final disappearance of its parental mate or homologue (*i. e.*, a small idiochromosome); and it is highly probable that this process has occurred in one sex only, namely, the male.<sup>1</sup> If this be the fact, it is evident that the heterotropic chromosome that remains in the male is the *maternal* mate or homologue of that which has vanished. I think therefore that we may expect to find that the heterotropic chromosome present in the male is derived in fertilization from the maternal group of chromosomes; and also that the female will be found to possess one more chromosome than the male (exactly the opposite of McClung's assumption), the additional chromosome being the homologue of that which has vanished in the male.<sup>2</sup> If this be the fact, it follows with great probability that in the egg-synapsis this chromosome pairs with its paternal homologue (originally the heterotropic chromosome) to form a symmetrical bivalent, and that all the eggs receive eleven chromosomes; while in the male the heterotropic chromosome fails to pair (having no mate) and hence remains univalent. The expectation may therefore be stated as follows:

Egg 11 + spermatozoön 10 = 21 (male).

Egg 11 + spermatozoön 11 = 22 (female).<sup>3</sup>

Important direct evidence in favor of this expectation is given by the discovery by Stevens, briefly referred to in my preceding paper, that in the beetle *Tenebrio* a small chromosome, evidently analogous to the small idiochromosome of Hemiptera, is present in the somatic cells of the male only, while in the female

<sup>1</sup>I will here not go into the somewhat intricate difficulties encountered under the supposition that it has occurred in both sexes, except to point out that if an unpaired heterotropic chromosome be present in the female and is allotted to only half the eggs (as in the male) it is necessary to assume a fertilization of each form of egg by the opposite form of spermatozoön, since otherwise three forms of offspring would result. Such a mode of fertilization is *a priori* very improbable. Still greater difficulties stand in the way of assuming that an unpaired heterotropic chromosome, present in the female, is retained in all of the eggs.

<sup>2</sup>Montgomery ('04) has in fact found in the oögonia and follicle-cells of the female *Anasa* twenty-two chromosomes, and Gross ('04) reports the same number in those of the female *Syromastes*. But since the first-named observer is certainly, and I believe the second-named is probably, in error as to the number in the male, both these cases require reëxamination. On the other hand Sutton has found twenty-two in the oögonia and follicle-cells of the Orthoptera (*Brachystola*) while the spermatogonial groups show twenty-three; but here again I think a result so important should be supported by more adequate evidence than he has brought forward. I now have this subject under investigation.

<sup>3</sup>For the confirmation of this, see Appendix.

it is represented by a corresponding larger one (both sexes having the same number of chromosomes). Were the small chromosome to disappear, the female would show one more chromosome than the male in accordance with my general assumption.

We have now therefore good reason to hope that observation will directly determine whether sex is predetermined in the chromosome-group; and further, whether the sex-determining function can be localized in a particular chromosome or pair of chromosomes, as McClung suggested.

5. The foregoing offers no specific suggestion as to the meaning of the four classes of spermatozoa observed in *Banasa*. But it may be remarked that the existence of two or four (or more) classes of germ-cells in the same sex is in itself nothing anomalous; for as Sutton has pointed out, under the conception of himself and Montgomery there may be as many classes of spermatozoa as there are combinations of paternal and maternal chromosomes (in accordance with the Mendelian ratios). Forms which possess idiochromosomes or heterotropic chromosomes differ from the more usual ones only in that two or four of these classes are made visible by a greater or less differentiation of the members of one or two of the chromosome-pairs. It seems admissible to suppose that such a visible differentiation of the members of particular chromosome-pairs may stand for a corresponding differentiation of corresponding or allelomorphic qualities in the adult. I would therefore suggest the possibility that such a visible polymorphism of the male germ-nuclei as exists in *Banasa* may be accompanied by a visible polymorphism in the adults; and, while I am not aware that such a polymorphism has been observed in the Hemiptera, I believe this subject should be carefully examined.

It is hardly necessary to point out, finally, how strong a support the foregoing observations lend to the general hypothesis of the individuality of chromosomes, and to the conception of synapsis and reduction first brought forward by Montgomery and developed in so fruitful a way by Sutton and Boveri. I must frankly confess that until I had followed step by step the behavior of the idiochromosomes and the *m*-chromosomes in the Hemiptera I did not appreciate how cogent is the argument brought forward in Montgomery's paper of '01 in support of his conclusion that synapsis involves an actual conjugation of chromosomes two by two, and that the

chromosomes thus uniting are the paternal and maternal homologues. In the case of the *m*-chromosomes, no less clearly than in that of the idiochromosomes, the conjugation is not in any way an inference but an easily observed fact; and in both cases it is equally clear that the subsequent reducing division separates, with their individuality unimpaired, the same chromosomes that have previously united in synapsis.

I believe that any observer who will take the trouble to study in detail the history of the chromosomes in these insects must sooner or later in his task acquire the firm conviction that he is dealing with definite, well characterized, entities which show the most marked individual characteristics of behavior, which in some manner persist from one cell-generation to another without loss of their specific character, and which unite in synapsis and are distributed in the ensuing maturation-divisions in a perfectly definite manner. All the facts indicate that these phenomena are the visible expression of a preliminary association, and subsequent distribution to the germ-cells, of corresponding hereditary characters. It is evident, therefore, that the time has come when cytologists must seriously set themselves to the task of working out a comparative morphology and physiology of the chromosomes, with the ultimate aim of attempting their specific correlation with the phenomena of heredity and development.

#### SUMMARY.

1. The chromosomes that have been called "heterochromosomes" in Hemiptera (Montgomery) include three distinct forms that may provisionally be called (*a*) the paired microchromosomes or *m*-chromosomes; (*b*) the idiochromosomes; (*c*) the "accessory" or heterotropic chromosomes.

2. The *m*-chromosomes are usually very small, form a symmetrical pair in the spermatogonia, and do not unite (in the forms I have studied) to form a bivalent chromosome-nucleolus in the growth-period. At an earlier or later period they condense to form two separate chromosomes that finally pair to form the small bivalent central of the first division, but are immediately separated without fusion. Each divides equally in the second division.

3. The idiochromosomes are typically unequal, and hence do not form a symmetrical pair in the spermatogonia. They may

or may not pair at the time of general synapsis to form a bivalent; in the former case they appear in the growth-period as a single bivalent chromosome-nucleolus, in the latter case as two separate univalent chromosome-nucleoli. In either case they undergo equal division as separate univalents in the first maturation-mitosis, their products conjugating at the close of this division to form an asymmetrical dyad the two constituents of which are, without fusion, immediately separated in the second division.

4. The heterotropic chromosome is without a mate in the spermatogonia (which accordingly show an odd number of chromosomes) and hence fails to undergo synapsis. Its behavior is throughout that of a univalent body. It divides only once in the course of the two maturation mitoses, this division taking place usually in the first, but in some species in the second, mitosis. It has probably arisen by the reduction and final disappearance of one member of a symmetrical chromosome-pair, this process having taken place in the male only.

5. The *m*-chromosomes are always associated with a heterotropic chromosome, while the idiochromosomes and heterotropic chromosomes are known to coexist in only a single case (Banasa). This case indicates that the formation of heterotropic chromosomes may have taken place more than once in the history of the species and possibly represents one mode of change from a higher to a lower number of chromosomes.

6. In forms possessing the idiochromosomes two classes of spermatozoa exist in equal numbers, which receive the same number of chromosomes but differ in respect to the idiochromosome. In forms possessing a heterotropic chromosome two classes of spermatozoa likewise exist, one of which possesses one more chromosome than the other. When both idiochromosomes and heterotropic chromosomes are present (Banasa) four classes of spermatozoa are formed, two having one more chromosome than the other two, each of these groups again differing in respect to the idiochromosome.

7. The facts support the general theory of the individuality of chromosomes, the theory of Montgomery in regard to synapsis, and that of Sutton and Boveri regarding its application to Mendelian inheritance; and they point toward a definite connection between the chromosome-group and the determination of sex.

## APPENDIX.

During the summer, and since the foregoing paper was entirely completed in its present form, I have obtained new material which shows decisively that the theoretic expectation in regard to the relations of the nuclei in the two sexes, stated at p. 539, is realized in the facts. In *Anasa*, precisely in accordance with the expectation, the oögonial divisions show with great clearness one more chromosome than the spermatogonial, namely, twenty-two instead of twenty-one; and the same number occurs in the divisions of the ovarian follicle-cells. Again in accordance with the expectation, the oögonial groups show four large chromosomes instead of the three that are present in the spermatogonial groups. In other respects the male and female groups are closely similar. In like manner, the oögonial divisions in *Alydus* and *Protenor* show fourteen chromosomes, the spermatogonial but thirteen; and in *Protenor* the spermatogonial chromosome-groups have but one large chromosome (unquestionably the heterotropic) while the oögonial groups have two such chromosomes of equal size.

The interpretation is unmistakable. Taking *Protenor* as a type, all of the matured eggs must contain seven chromosomes, of which one, much larger than the others, corresponds to the heterotropic chromosome present in one-half of the spermatozoa. These spermatozoa (seven-chromosome forms) contain a chromosome-group exactly similar to that of the egg; and fertilization by a spermatozoön of this class produces a female having fourteen chromosomes. The other half of the spermatozoa (six-chromosome forms) lack the heterotropic chromosome; and fertilization of an egg by a spermatozoön of this class produces a male having but thirteen chromosomes, the unpaired one being derived from the egg and appearing in the maturation of this male as the heterotropic chromosome since it is without a mate. There can, therefore, be no doubt that a definite connection exists between the chromosomes and the sexual characters, and I believe that the conclusion can hardly be escaped that the chromosome-combination, established at the time of fertilization, is, in these insects, the determining cause of sex.

The result reached in *Anasa* is confirmed by a comparison of the male and female chromosome-groups in *Lygæus*, *Cœnus* and *Euschistus*, all of which possess in the male a pair of unequal

idiochromosomes in place of an unpaired heterotropic chromosome. In all of these forms, as I showed in my first paper, the spermatogonial groups show fourteen chromosomes that may be equally paired with the exception of a small and a large idiochromosome. The oögonial groups in these forms also show fourteen chromosomes, but all may be equally paired, the small idiochromosome being represented by a larger one that has a mate of equal size. In these forms, accordingly, males are produced as a result of fertilization by spermatozoa containing the small idiochromosome, females by fertilization by spermatozoa containing the large idiochromosome (which accords with Stevens' result in *Tenebrio*). This proves the correctness of my conclusion that the size-reduction and final disappearance of the small idiochromosome has taken place in the male sex only, and that the large idiochromosome corresponds to the heterotropic chromosome. Complete disappearance of the small idiochromosome in the male has led to each a condition as exists in *Anasa* and other forms possessing a heterotropic chromosome. These facts will be described and discussed in the third of these studies.

October 4, 1905.

LITERATURE.<sup>1</sup>

- BAUMGARTNER, W. J., '04.—Some new Evidences for the Individuality of the Chromosomes. *Biol. Bull.*, viii, 1.
- BOVERI, TH., '04.—Ergebnisse über die Konstitution der Chromatischen Substanz des Zellkerns. *Jena*, 1904.
- GROSS, J., '04.—Die Spermatogenese von *Syromastes marginatus*. *Zoöl. Jahrb., Anat. Ontog.*, xx, 3.
- HENKING, H., '90.—Ueber Spermatogenese und deren Beziehung zur Entwicklung bei *Pyrochoris apterus*. *Z. wiss. Zoöl.*, li.
- McCLUNG, C. E., '00.—The Spermatocyte Divisions of the Acrididæ. *Bull. Univ. Kansas*, ix, 1.
- '02, 1.—The Spermatocyte Divisions of the Locustidæ. *Ibid.*, xi, 8.
- '02, 2.—The Accessory Chromosome. Sex Determinant? *Biol. Bull.*, iii, 1, 2.
- MONTGOMERY, T. H., '98.—The Spermatogenesis in *Pentatoma*, etc. *Zoöl. Jahrb., Anat. Ontog.*, xii.
- '01.—A Study of the Chromosomes of the Germ-cells of Metazoa. *Trans. Amer. Phil. Soc.*, xx.
- '04.—Some Observations and Considerations upon the Maturation Phenomena of the Germ-cells. *Biol. Bull.*, vi, 3.
- '05.—The Spermatogenesis of *Syrbula* and *Lycosa*, etc. *Proc. Acad. Nat. Sci. Phil.*, Feb., 1905. Issued May 18, 1905.
- MOORE AND ROBINSON, '05.—On the Behavior of the Nucleolus in the Spermatogenesis of *Periplaneta Americana*. *Q. J. M. S.*, xlviii, 4.
- PAULMIER, F. C., '99.—The Spermatogenesis of *Anasa tristis*. *Jour. Morph.*, xv, supplement.
- STEVENS., N. M., '05.—A Study of the Germ-cells of *Aphis rosæ* and *Aphis œnotheræ*. *Journ. Exp. Zoöl.*, ii, 3.
- SUTTON, W. S., '00.—The Spermatogonial Divisions in *Brachystola magna*. *Bull. Univ. Kansas*, ix, 1.
- '02.—On the Morphology of the Chromosome Group in *Brachystola magna*. *Biol. Bull.*, iv, 1.
- '03.—The Chromosomes in Heredity. *Biol. Bull.*, iv, 5.
- WILSON, E. B., '05.—The Behavior of the Idiochromosomes in Hemiptera. *Journ. Exp. Zoöl.*, ii, 3.

---

<sup>1</sup>Including only works directly cited in the text. A full literature-list is given in the works of McClung ('02, 2) and Montgomery ('05).





# VARIATIONS AMONG SCYPHOMEDUSÆ.<sup>1</sup>

BY

CHAS. W. HARGITT.

WITH 1 PLATE AND 17 FIGURES IN THE TEXT.

During the course of a study of variations among *Hydromedusæ* in 1901 the present writer became interested in facts of a similar sort which came under observation incidentally as certain specimens of various *Scyphomedusæ* were observed. Furthermore, during the course of extended studies in the development of *Cyanea* additional facts of a very interesting kind were observed. Still later in connection with experiments on regeneration in *Rhizostoma pulmo* ('04) other facts bearing more or less directly upon the same general problem were accumulated.

It is the purpose of the present paper to present a synopsis of the facts and to attempt a statistical exhibit of certain features of the variations observed, as well as an analysis of the data with a view to determine something of their bearings on the general problem of adaptation.

## MATERIAL.

Most of the material was obtained at Woods Hole during the summers of 1901, 1902, 1905. Most of the ephyræ were obtained in April and May 1902, and in March 1904. The adults were collected by the writer at various times during these years in part, and in part by Mr. Vinal N. Edwards, collector for the laboratory of the United States Fish Commission, for whose kindness in turning it over to me for investigation it is a pleasure to acknowledge my grateful obligations. I was also permitted to examine a collection of about two hundred specimens of *Aurelia* collected by Mr. Geo. M. Gray, curator of the Marine Biological Laboratory supply department, for which courtesy my thanks are due.

The material was preserved for the most part in 5 per cent formalin. That of my own collecting was preserved in formalin

---

<sup>1</sup>Contributions from the Zoölogical Laboratory, Syracuse University.

after treatment with the chromic acid method suggested by Browne, to the excellent results of which I am glad to certify.

My thanks are due to my son, George T. Hargitt, who has drawn most of the diagram sketches.

#### AURELIA FLAVIDULA.

The general facts of variation, or abnormality, as formerly regarded, in species of *Aurelia* have long been known. It is no part of the purpose of this paper to review in detail the history of observations along this line, yet it may not be amiss to cite some few of the more noteworthy among them. In a recent paper, "Über Hypomerie und Hypermerie bei *Aurelia aurita* Lem.," Ballowitz has given a brief summary of the more important literature.

Von Baer<sup>1</sup> seems to have been among the first to record observations upon the several numerical variations in *Aurelia aurita*, and to point out certain correlations noticed, as well as their absence in some cases. According to this author the variation was estimated to be about 10 per cent.

Of more critical character are the observations of Ehrenberg<sup>2</sup> in 1835. This naturalist in an extended paper "Über die Acalephen des rothen Meeres, etc.," reports with considerable detail upon variations observed in this medusa, and illustrates by numerous figures the more conspicuous aspects of the problem. He was able to confirm the earlier observations of von Baer, and considerably to extend them. Among many thousands of specimens casually noticed, and several hundreds examined with care he records having seen but two specimens of octamerous division of the gonads and comparatively few having a three-, five- and six-merous character. He records a single specimen observed with but one circular gonad about the mouth, which he considered to have been the result of a fusion of three or six single organs, as there were several openings into the stomach. In a case having double gonads he considered the condition to be due to a similar fusion of six organs as there were six openings distinguished. Like von Baer, this observer also recognized a

---

<sup>1</sup>Über *Medusa aurita*, Meckels Archiv f. Physiol., Bd. viii, 1823.

<sup>2</sup>Abhandl. d. Königl. Akad. Wissenschaften, Berlin, 1835, S. 199-204, 1837.

more or less perfect correlation among the several variable organs of the medusa, but also cites and figures an exceptional case in Taf. II, Fig. 12, in which in a rare octamerous specimen there were found fourteen rhopalia and twenty-eight principal canals, instead of sixteen and thirty-two respectively, as required to complete the symmetry. According to this author the ratio of variation was *estimated* as about 10 per cent (though Agassiz in a following quotation seems to have overlooked this point in Ehrenberg's work). It is not specified as to whether this includes the totality of variations, or refers to those of the vegetative organs. If the *former* it was probably too low; if the *latter* probably too high, as will be seen in the following data:

Haeckel<sup>1</sup> has recorded numerous facts of variation among European species of *Aurelia* and suggested their significance in relation to problems of evolution, though in his earlier account no details were given. In a later contribution<sup>2</sup> he has, however, discussed the problem in much detail, not only in connection with the adults but also in relation to the embryonic development, from segmentation and gastrulation on through the several transitional stages—scyphostoma, strobila and ephyra—up to the adult, giving excellent figures and descriptions of typical examples.

This author strongly maintains that numerical variations sustain intimate relationships throughout the entire ontogeny, and quotes Claus as holding similar views. "Ich nehme mit Claus an, dass alle Zahlenabnormitäten der reifen *Aurelia* schon bei ihrer *Ephyryla*-larve auftreten, und dass diese letztere sie bereits von ihrer *Scyphostoma*-amme geerbt hat. Wenn also *Scyphostoma* nur 2 gegenständige *Tæniolen* besitzt, so zeigt ihre *Ephyryla* nur 2 gegenständige *Filamenten* und die reife *Aurelia* später nur 2 gegenständige *Gonaden*."

In connection with the recent interest in the general problems of variation several brief accounts have appeared in reference to this medusa, but only two have gone into any details as to facts, or undertaken any analysis of them, namely, Browne<sup>3</sup> who in several contributions has discussed with pains and ability a very large number of observations made upon both adult and ephyrae;

<sup>1</sup>Das System der Medusen. Jena, 1879.

<sup>2</sup>Metagenesis und Hypogenesis von *Aurelia aurita*, S. 26. Jena, 1881.

<sup>3</sup>Quart. Journ. Mic. Soc., vol. xxxvii, pp. 245. Biometrika, vol. i, p. 90. 1901.

and Ballowitz,<sup>1</sup> who has devoted attention chiefly to adults, giving excellent figures of noteworthy variations, and includes also a valuable review of literature.

In view of these rather extended observations on the part of European observers and the almost entire lack of similar study of American medusæ it has seemed to the writer for several years that a comparison of *Aurelia flavidula* with *Aurelia aurita* might afford valuable results. And with this in view the data presented in the following pages have been worked out at such intervals during the past three years as have been available. I regret very much that a larger number of adult specimens have not been available, the hope of securing which has delayed the final appearance of the paper. It is believed, however, that sufficient data are presented to show at least something of the extent and significance of the variations.

As already intimated, almost nothing along these lines has been attempted in relation to American Scyphomedusæ, while the summary of observations by the present writer is all that has been attempted on the Hydromedusæ. L. Agassiz<sup>2</sup> has left a few very brief and rather indefinite records of variation in *Aurelia flavidula*. Concerning numerical variation he says: "These variations in number arise from the interpolation of similar parts, or from the abortion of some of them. I have observed on our coast specimens with three, five, six and seven crescent-shaped bodies, and the number of indentations along the margin increased correspondingly. These deviations from the normal number are rare with our species, and though Ehrenberg does not allude to their frequency in the European, I should infer that they are more frequent in *Aurelia aurita* than in *Aurelia flavidula*, for the simple reason that malformations of the crescent-shaped bodies are rarely met with in our species."

As will be noted, there is apparent in these observations of Agassiz, the same general assumption of a more or less close correlation among the several organic systems of the medusæ. I am inclined to regard this as in some measure due to a temperamental predisposition on the part of these earlier observers, perhaps growing out of the peculiar ideas in reference to such matters

<sup>1</sup>Archiv. f. Entwicklungsmechanik der Organismen, Bd. viii, S. 239. 1898.

<sup>2</sup>Contr. Nat. Hist. U. S., 1862, vol. iv, p. 51.

more or less prevalent at that time. Certain it is, that either the more recent work on these lines have been more critical and discriminating, or a remarkable change has taken place since the earlier records were made. Possibly something of both may be true, though I incline to regard the former as more probable.

My investigations have been directed chiefly to two series of facts, namely: Variations as exhibited in the ephyra, and those found in the adult of *Aurelia flavidula*. Incidentally I shall direct attention briefly to certain other species which have been studied in connection with those of *Aurelia*, though of these no details will be undertaken, since in only a few cases have sufficient numbers been examined to warrant any general conclusions.

Being strongly convinced of the general correctness of Haeckel's view as to the relations of variations of the adult to similar conditions found in the larva, or ephyra, it seemed desirable to secure collections of specimens from various localities differing more or less in physical conditions of environment in order to estimate the probable influence of such conditions in relation to variation. Accordingly I secured ephyrae from three localities adjacent to Woods Hole, in about equal numbers, approximately 500 from each. (Unfortunately I was unable to obtain adults from the same environments, since their locomotor powers, influence of currents, winds, etc., carrying them every whither, made this quite impracticable.)

As is very well known, the *Discomedusæ* are characterized in general by the octamerous lobing of the umbrellar margin, correlated with which are eight rhopalia, or sensory bodies; and by the tetramerous form of the stomach and oral arms. This is more particularly the case with the semostomous group, to which belong most of our larger medusæ, of which *Aurelia* and *Cyanea* are good examples.

As will be seen, therefore, the organization of these medusæ, leaving out of account the tentacles, which differ greatly in the several genera, presents two fairly differentiated and independent sets of organs, namely, the marginal or sensory, and the central or vegetative. In many cases these sets are correlated for nutritive purposes through the radial canal system, though of themselves they may for the present discussion be considered as independent systems, distinctively organized and definitely correlated, as

indicated above. In keeping with this view we may naturally proceed upon our analysis and comparisons under two heads:

(1) The marginal system; and (2) the nutritive and reproductive, or vegetative system.

Concerning the canal system nothing will be said in connection with the study of the ephyræ, since during the early larval history this system is but slightly developed and therefore of but small consequence in relation to variation.

Furthermore, since as already suggested the purpose is in part a comparison of the aspects of variation presented by the ephyra and adult, we have again a two-fold division of the subject. And since in the order of nature the ephyra precedes the adult this may as well be taken as the order of research.

#### *Variation in the Ephyra.*

Aside from the investigations of Haeckel (*op. cit.*), so far as I am aware Browne is the only investigator who has taken up this phase of the subject in detail. And furthermore, since heretofore investigation has been directed almost wholly to European species it has seemed to me highly desirable that similar observations be made upon those of American waters, in order to have some broader basis of comparison and deduction.

#### Marginal Organs.

The ephyræ studied are of two series, first those collected in 1901-02, and second, those collected in 1904. I choose to consider them in this detached way chiefly from the fact that the latter were just in process of metamorphosis into young Medusæ, and it seemed better to study them with a view to securing possible evidence as to any ratio of selection which might be detected as occurring during this process. The ephyræ were all of *Aurelia flavidula*, except possibly a stray specimen of *Cyanea* which might have drifted among them. But these were exceedingly rare, if occurring at all, since an examination of several hundred of the series of 1904 in process of metamorphosis failed to reveal the presence of a single specimen. Moreover, since in an earlier study of the development of *Cyanea* I found abundant evidence of similar variation, the presence of an occasional specimen in the estimation of percentage variation could hardly affect the results.

Of the first series a total of 1512 specimens were examined. Of this number 398 or 26 per cent showed variations in some one or more of the organs. Of specimens having less than the normal number of marginal organs there were but 19, or 1.25 per cent. Of those having more than the normal number of these organs there were 379, or 25 per cent. Details concerning these data are given in tabulated form in the following tables.

TABLE I.—Showing Correlations of Marginal Lobes and Rhopalia.

		RHOPALIA.										
		5	6	7	8	9	10	11	12	13	14	TOTALS
MARGINAL LOBES.	5	1										1
	6		1									1
	7			15	13							28
	8			2	1114	5						1121
	9				7	206	4					217
	10					2	84	1				87
	11					1	1	28				30
	12							3	13			16
	13							1		8		9
	14										2	2
TOTALS		1	1	17	1134	214	89	33	13	8	2	1512

Table I presents in graphic form the correlations existing between the marginal lobes and the rhopalia. In the vertical column at the left are given the number of marginal lobes ranging from 5 to 14, the smallest and largest number respectively found in any specimen. In the horizontal column at the top are

given the number of rhopalia, while the number of specimens are arranged in the squares. While in general there is a very close correlation between these organs it will be seen that there are not infrequent departures from this rule, or in other words absence of correlation. For example, two specimens were found having only seven rhopalia while there were eight marginal lobes. Likewise there will be seen to be five specimens having more rhopalia than marginal lobes in normal octamerous individuals. A simi-

TABLE II.—*Showing Correlations of Oral and Gastric Lobes.*

		ORAL LOBES.						
		2	3	4	5	6	7	TOTALS
GASTRIC LOBES.	2	I						I
	3		I	3				4
	4		2	474				476
	5				I			I
	6					3		3
	7						I	I
	TOTALS	I	3	477	I	3	I	486

lar condition of variation is shown in specimens having seven, nine, ten, eleven, and twelve marginal lobes and rhopalia.

A curve constructed by which to portray even more graphically the facts would involve the following factors:<sup>1</sup>

	MARGINAL LOBES. RHOPALIA.	
Mean variation .....	8.396	8.379
Standard deviation .....	.896	.872
Coefficient of variability.....	1.06	1.04
Probable error of mean .....	± .015	± .002
Probable error of standard deviation .....	± .011	± .011
Average deviation .....	.626	.641

<sup>1</sup>For calculating the factors of this curve I am under obligations to my colleague, Dr. Smallwood.



A study of the table will naturally give rise to the question as to how the several variations in these marginal organs are to be explained. For example it will be observed that twenty-three specimens had more rhopalia than marginal lobes. A reference to Figs. 1 to 3 will quickly afford an explanation of this phenomenon. The figures also show double and twin rhopalia, several cases of which were found. Similar cases are cited by Browne (*op. cit.*, p. 90), and in connection with their discussion he ventures the suggestion that perhaps in later development and during metamorphosis, by a growth of the margin these so-called twin rhopalia may become separated thus giving rise to an independent lobe. This seems to me to be extremely doubtful. As a matter of fact it is well known that during growth following metamor-

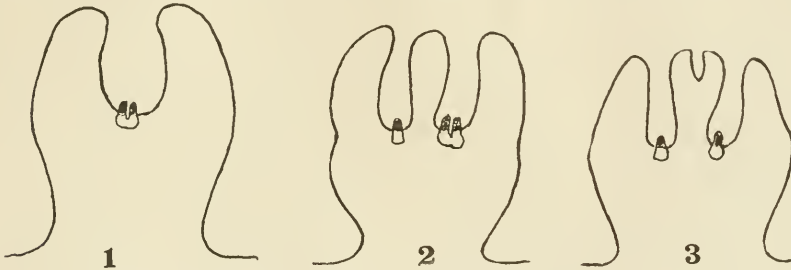

Fig. 1. Diagram of marginal lobe showing twin rhopalia.

Fig. 2. Compound marginal lobe, one of which contains twin rhopalia.

Fig. 3. Compound marginal lobes the central one notched at the tip.

phosis, increase of the marginal dimension takes place entirely by growth of the inter-rhopalial areas. This is very easily seen by a study of the appearance of new marginal tentacles and by the origin and multiplication of the branching canals. It may therefore be accepted as practically certain that the twin rhopalia of the ephyra continue such in the adult medusa. It is also almost certain that a similar condition is involved in the case of such double rhopalia as are shown in Figs. 3 and 4. In these respects, as in others, as cited by Haeckel (*op. cit.*) we may, I believe, regard it as undoubtedly true that the larval variations are carried over into the adult through the several phases of metamorphosis. Furthermore, this view is confirmed by the facts clearly established, that the ratio of variation found in the adults is essentially the same as that found in the ephyrae.

As suggested above, it seems reasonably clear that the excess of rhopalia may be accounted for in the manner already proposed. But it remains to consider those cases in which the number of marginal lobes is in excess of the number of rhopalia. Of these there were found seventeen cases, as against twenty-three of the former. It is quite obvious that for these a different explanation must be found. We are here limited to two alternatives, namely, either there are cases in which for some reason there has been a failure of a given lobe to develop its usual organ; or on the other hand there may possibly be a subsequent and independent origin of an extra lobe. While I have found undoubted cases of the occurrence of the former condition, and am constrained to regard it as the more usual and probable explanation, at the same time I have found an occasional case in which a belated lobe appears to arise after the ephyra has become free from the strobila, but at the same time it must be admitted that in these cases there is usually found the accompanying rhopalium, though this is not always true. I am therefore constrained to consider both alternatives as possible, though giving to the first the larger probability.

A few unusual features in the marginal and rhopalial variations call for a merely passing notice. Fig. 1, showing an ordinary twin rhopalium, calls for little note aside from the statement of fact that it plainly occupies the position and relation of a typical organ, namely, the terminus of a single canal. And in this connection it may be well to recall that in the early ephyra-life all the canals are simple, that is, unbranched. It is only during the progress of metamorphosis that the complexity of the adult canal system is gradually differentiated.

Figs. 2, 3, show a series of extremely interesting variations of graduated complexity. The first shows a trifid condition of the otherwise normal ephyra lobe, though with the added abnormality of twin rhopalia in one of the notches. In the second there is shown a quadrifid lobe, the lappets of the median pair being small and not particularly remarkable, while in each notch of the outer lappets is a normal sensory body. Several other figures show similar features.

Among 486 ephyrae taken in the "eel pond," Woods Hole, in April, 1902, the variants numbered 144, or 29.6 per cent.

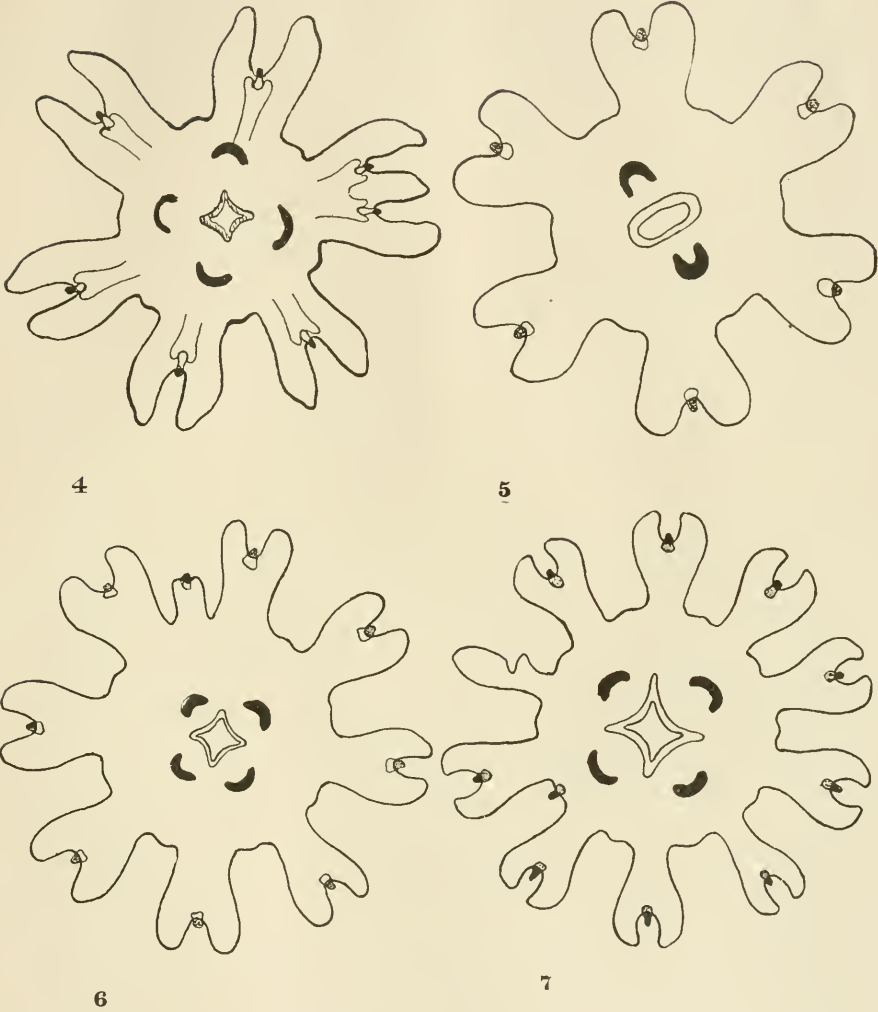

Fig. 4. Hexamerous ephyra, one lobe of which is compound.

Fig. 5. Hexamerous ephyra, with two-lobed mouth, and two gastric lobes.

Fig. 6. Ephyra with small supernumerary rhopalium, several examples of which were found.

Fig. 7. Ephyra with an adradial rhopalium, and one of the normal lobes devoid of an organ, perhaps due to injury.

TABLE III.

NO. SPECIMENS.	GASTRIC LOBES.	ORAL LOBES.	RHOPALIA.	MARGINAL LOBES.
1	2	2	6	6
1	3	3	7	7
1	3	4	7	7
2	3	4	9	9
1	4	3	10	10
1	4	3	12	12
78	4	4	9	9
1	4	4	8	9
35	4	4	10	10
2	4	4	9	10
8	4	4	11	11
7	4	4	12	12
1	5	5	10	10
1	6	6	11	11
1	6	6	12	12
1	6	6	13	13
1	4	4	14	14
1	7	7	10	10

Each of these rhopalia occupied a single octant of the ephyra margin, and differed but little in size from the others. It should be stated that each was found on a different specimen.

In two specimens were found a very rare feature among these varied rhopalial phenomena, namely, the presence of a rhopalium in an interobular, or adradial position, as shown in Figs. 6, 7. One of such cases I also discovered in connection with the study of the development of *Cyanea*. Here we probably have the origin of the condition which eventuates in the equally rare occurrence of an adradial rhopalium in the adult medusa, cases of which will be considered in a later connection.

#### Oral and Gastric Organs.

As compared with the marginal system that of the vegetative shows comparatively little variation, at least in the ephyra stage, though the present data are far from complete. In the first place

the number of specimens tabulated was less than one-third of the entire number in the preceding series. This is due in part to the poorly differentiated stage of these organs in the early ephyra, the gonads being entirely lacking, and the mouth-lobes being often so contracted as to render certain determination impossible.

In Table II is shown the range of variation so far as accurate data are at command, including as in Table I divergencies or lack of correlation between the two sets of organs.

As will be noted, out of a total of 486 specimens, only 12 or 2.68 per cent vary from the normal.

In several figures are shown illustrations of these aspects of our subject. In Fig. 5 is shown a sketch of one of these, in which there are but two oral divisions and two gastric pouches. One might suppose the directly opposite relations of these organs as figured to be unusual, but when compared with Figs. 6 and 7 it will be seen to be quite in keeping with that found in almost every case, that is, the angles of the mouth correspond with those of the stomach so that the pouches of the latter of course occupy intermediate positions. In other words, the angles of the mouth occupy the perradii of the body while the gastric pouches or lobes occupy the interradii.

A comparison of figures will readily show the lack of correlation of these organs with those of the marginal system, and at the same time the close correlations between themselves, the latter being likewise evident in the data of the table.

Additional data of a similar sort will be presented in connection with the second series, a comparison of which will still further emphasize the small ratio of variation as compared with that of the marginal organs.

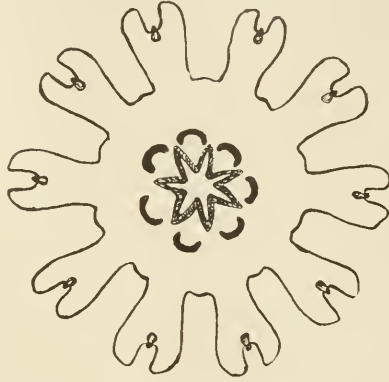

Fig. 8. Ephyra with seven gastric and oral lobes, and ten marginal lobes.

*A Comparison of the Variations Exhibited by Ephyrae During Metamorphosis.*

During the current summer, 1905, I was able to secure a collection of about 1000 ephyrae from Waquoit Bay, a body of water some ten miles east of Woods Hole, from which had also been secured a portion of the previous series in 1901. Among these were found 392 specimens which were just emerging into young medusae. They varied in size from 7 to 14 mm. in diameter, the radial canals were well differentiated, and the gastric pouches easily distinguishable. There were also 218 ephyrae among the number which were entirely devoid of any indications of metamorphosis, indeed, apparently but recently escaped from the strobila. I was particularly glad to have an opportunity to study a series of this character from a strictly local environment and from the same brood, so to speak, since it afforded an opportunity to test a feature of variation already referred to, namely, whether varietal features existing in one stage are carried over into another, or whether during a period of metamorphism there was at work any selective processes.

While the numbers examined in these cases are too small to afford conclusive data on a problem of this character, they may at any rate afford a fair indication as to probabilities, and when taken in comparison with similar series in larger numbers, as in the former case, and also in connection with the observations of Browne (*op. cit.*), they may become correspondingly more convincing.

A comparison of the data presented in Tables IV and V will show, both in relation to the percentage variation and to the question of the persistence of varietal features during the several phases of metamorphism, rather striking points of likeness. So far as the ratio of variation is concerned it will be seen at a glance that it is so nearly the same in the several cases as to preclude the probability of anything more than slight and incidental differences. For example, in Table I the total per cent of variation is 26; in Table V it is 22.2; while in Table IV it is 22.9. Compared with the ratio obtained by Browne, which for 359 ephyrae taken in 1893 was 22.6, and for 1116 specimens taken in 1894 was 20.9, the results become still more conclusive.

Of 218 ephyræ taken at Waquoit Bay in April, 1904, there were 50 variants, or 22.9 per cent. The chief features are tabulated as follows:

TABLE IV.

NO. OF SPECIMENS.	GASTRIC LOBES.	ORAL LOBES.	RHOPALIA.	MARGINAL LOBES.
1	3	3	6	6
1	3	3	7	7
2	4	4	6	6
2	4	4	7	7
31	4	4	9	9
4	4	4	10	10
1	4	4	11	11
1	4	4	12	12
1	5	5	11	11
1	5	5	12	12
1	6	3	12	12
3	6	6	12	12
1	6	7	12	12

Now if we compare these results with those shown in Tables VI and VII, in which are presented in detail the variations found in 226 specimens of young *Aurelia flavidula* taken at Waquoit Bay in May, 1905, and in a collection of adults made at New Bedford about the same time it will be seen that they all tend to confirm the general propositions under consideration, namely, that varietal features found in the ephyra persist in the adult, and furthermore, that there is no evidence of any selective process involved during these several changes in ontogeny.

Of 392 ephyræ in process of metamorphosis, taken at Waquoit Bay in April, 1904, there were 87 specimens, or 22.2 per cent., which showed various aspects of variation, the principal features of which are classified in the following tabulated form:

TABLE V.

NO. OF SPECIMENS.	GASTRIC LOBES.	ORAL LOBES.	RHOPALIA.	CANAL SYSTEM.
1	2	2	6	Perradial ..... 0 1 1 1 Interradial ..... 0 1 1 1
1	3	4	7	Perradial ..... 1 1 1 1 Interradial ..... 0 1 1 1
2	4	4	7	Perradial ..... 0 1 1 1 Interradial ..... 1 1 1 1
1	4	4	7	Perradial ..... 1 1 1 1 Interradial ..... 0 1 1 1
45	4	4	9	Perradial ..... 2 1 1 1 Interradial ..... 1 1 1 1
11	4	4	10	Perradial ..... 2 2 1 1 Interradial ..... 1 1 1 1
4	4	4	10	Perradial ..... 2 1 2 1 Interradial ..... 1 1 1 1
1	4	4	10	Perradial ..... 3 1 1 1 Interradial ..... 1 1 1 1
3	4	4	11	Perradial ..... 2 2 2 1 Interradial ..... 1 1 1 1
1	4	4	11	Perradial ..... 2 2 1 1 Interradial ..... 1 1 1 1
1	4	4	12	Perradial ..... 2 2 2 2 Interradial ..... 1 1 1 1
1	4	4	13	Perradial ..... 2 2 2 2 Interradial ..... 2 1 1 1
1	4	4	15	Perradial ..... 3 3 3 2 Interradial ..... 1 1 1 1
1	6	5	11	Perradial ..... 2 1 1 1 1 Interradial ..... 1 1 1 1 1
6	6	6	11	Perradial ..... 1 1 1 1 1 1 Interradial ..... 0 1 1 1 1 1
2	6	6	12	Perradial ..... 1 1 1 1 1 1 Interradial ..... 1 1 1 1 1 1
1	6	6	13	Perradial ..... 1 1 1 1 1 1 Interradial ..... 2 1 1 1 1 1
1	6	5	13	Perradial ..... 2 1 1 1 1 1 Interradial ..... 1 1 1 1 1 1
1	6	6	13	<i>Ibid.</i>
1	6	8 (double)	15	<i>Cf. Fig. 10.</i>
1	8	8	13	Perradial ..... 0 1 1 1 1 1 1 1 Interradial ..... 0 0 1 1 1 1 1 1



*Variations in the Adults.*

As in the study of the ephyræ attention was directed chiefly to the marginal or sensory bodies, and to the central or vegetative, so likewise in the study of the adults the same systems have received primary consideration, though in the latter including also the canal system, as a correlating medium between the others. Attention was also directed to the problem of the probable influence of local conditions in determining variations. As favorable localities from which to secure specimens more or less subject to a definite environment, New Bedford harbor and Waquoit Bay were selected, the latter serving moreover, the further end of ascertaining the variations exhibited by ephyræ and adults under the same environment.

In addition to authorities cited in a previous part of this paper attention may be directed to the observations of Bateson and Romanes on the variations of *Aurelia aurita*. The latter has described in some detail variations found in this medusa and has illustrated by diagrams many of the features described. In both the illustrations and the analysis of the facts there is an apparent effort of the author to reduce the variations to as few symmetrical types as possible. As I have pointed out in another connection in reference to the work of Ehrenberg and Agassiz, these attempts to discover a law of symmetry, or perhaps better in modern phrase, a law of *regulation*, in the diverse variations encountered, have apparently been only partially justified. While it is doubtless true that in many cases, perhaps in a majority, some form of regulation may be distinguished, there are too many cases in which this is lacking to be considered as merely exceptions to such a law. A study of the following facts and illustrations, will I believe justify this view.

As Bateson in commenting upon Romanes' work has remarked, "It is impossible in regular threes, sixes, etc., to say that any particular segment is missing or added rather than another." And if this be the case with an organism like *Aurelia*, in which the several organs are so sharply differentiated as to be easily distinguished at a glance, it is much more likely to be true in organisms of more complex structure and less sharpness of differentiation.

In an attempt to ascertain the comparative frequency of certain

variations in Aurelia, Bateson examined 1763 adult specimens taken on the Northumberland coast in 1892. In the tabulation of his results he presents details of only the gonads and oral lobes. Of these there were but 28 abnormal specimens, or a variation of only 1.6 per cent. Of the 28 abnormal individuals 19 he considers as "symmetrical varieties," and observes that the other 9 specimens, or 33 per cent are "irregular varieties" and are seen "for the most part in single specimens only." Here Bateson apparently falls into the same error which he has criticized in Romanes, namely, the attempt to reduce the variations to "symmetrical varieties," regarding "irregular varieties" as exceptional. But the presence of 33 per cent of the so-called "irregular varieties" is too large a proportion to be designated as exceptions.

As is well known Aurelia is an octamerous medusa, each octomere being characterized by a single, more or less dichotomously branched radial canal, at the terminus of the central stem of which is located the sensory body, or rhopalium, and separated from the adjacent octomere by an unbranched canal, as shown in several of the diagrams. In normal individuals this arrangement is very symmetrical, and easily distinguishable. It must not be inferred, however, that the several branching canals are exactly similar, or symmetrical. Indeed it may be safely said that probably no two in a given individual are exactly alike, any more than are two leaves of a given plant. Still, the differences are usually slight, striking variations occurring chiefly in those cases where departures from the typical arrangement are considerable. For convenience in following readily the subsequent discussions, it may be well to briefly remind the reader that for descriptive purposes the several canals have been designated by the special names, *perradial*, signifying those canals arising between the gastric pouches, or mouth angles; *interradial*, indicating those occupying intermediate positions, or emerging from the outer median portion of the gastric pouches; while the term *adradial* refers to the unbranched canals alternating with the other two series.

#### Gastric and Reproductive Organs.

Among the most conspicuous variations from the typical condition just described are those involving a numerical, or meristic departure. This will be readily understood when it is remembered

that these organs are large and conspicuous, four in number, and usually the first to attract attention. It is doubtless on this account that so many of the earlier observations concerning variation in these medusæ dealt almost exclusively with this feature.

Among the commonest variation is the hexamerous form, where there are six each of the gastric lobes, gonads, and oral arms. This will be observed at a glance by comparing the several tables, especially Nos. IV and V. Next in frequency is the pentamerous type, where there is a symmetrical arrangement of the organs upon the plan of five. As the several details of these variations are specified so far as their numerical aspects are concerned it is only necessary to refer to the tables already cited. It may be well to notice briefly a few features not capable of tabulation. Among these are the not infrequent occurrence of signs of atrophy, as shown in Figs. 11 and 12. In the former it will be observed that associated with the small size of the pouch and gonad is the entire absence of the interradial canal and its marginal organ. In the latter will be observed the presence of a mere rudiment of a regressive gonad in one of the pouches, while in the opposite compound pouch there are two gonads, and in this case the absence of the perradial canal system.

Associated with variations in the number, is that of variation in the size and relations of the organs, as already pointed out in the figures cited. Attention was directed to the compound character of the organs. This is a very common occurrence, and probably is indicative of the manner of the origin of supernumerary organs of this character. However, the pentamerous and hexamerous condition is frequently distinguishable in the ephyra, and seem to be quite distinct from the beginning. And I have found in *Cyanea* that occasionally trimerous polyps occur, and probably give rise to trimerous ephyræ and later trimerous medusæ. It may not be improbable that the suggestion of Ehrenberg (*op. cit.*), that the circular gonads which he observed were the result of fusion of what may have been earlier distinct organs, is quite as likely as that above. It may be suggested in this connection that I have never seen a case such as that cited by Ehrenberg, though its occurrence does not seem improbable, but in every case which has come under my observation of a compound gastric pouch, the gonads have been more or less distinct, as indicated in Fig. 12.

Of 226 small adults collected at Waquoit Bay, May, 1905, there were 55 variants, or 24.3 per cent. The general features of variation are tabulated as follows:

TABLE VI.

NO. OF SPECIMENS.	GASTRIC LOBES.	ORAL LOBES.	RHOPALIA.	CANAL SYSTEM.
1	4	3	8	{ Perradial ..... 1 1 1 1 Interradial ... 1 1 1 1
1	4	4	7	{ Perradial ..... 0 1 1 1 Interradial ... 1 1 1 1
3	4	4	7	{ Perradial ..... 1 1 1 1 Interradial ... 0 1 1 1
26	4	4	9	{ Perradial ..... 2 1 1 1 Interradial ... 1 1 1 1
7	4	4	9	{ Perradial ..... 1 1 1 1 Interradial ... 2 1 1 1
5	4	4	10	{ Perradial ..... 2 1 1 1 Interradial ... 2 1 1 1
2	4	4	10	{ Perradial ..... 2 1 2 1 Interradial ... 1 1 1 1
2	4	4	10	{ Perradial ..... 3 1 1 1 Interradial ... 1 1 1 1
2	4	4	10	{ Perradial ..... 2 2 1 1 Interradial ... 1 1 1 1
2	4	4	11	{ Perradial ..... 2 2 2 1 Interradial ... 1 1 1 1
1	4	4	11	{ Perradial ..... 2 2 1 1 Interradial ... 2 1 1 1
1	4	4	11	{ Perradial ..... 3 1 2 1 Interradial ... 1 1 1 1
1	6	6	11	{ Perradial ..... 0 1 1 1 1 1 Interradial ... 1 1 1 1 1 1
1	6	6	12	{ Perradial ..... 1 1 1 1 1 1 Interradial ... 1 1 1 1 1 1

Of 129 large adults taken at New Bedford in May, 1905, there were 29 variants, or 22.5 per cent. The chief features of variation are shown in the following table:

TABLE VII.

NO. OF SPECIMENS.	GASTRIC LOBES.	ORAL LOBES.	RHOPALIA.	CANAL SYSTEM.
1	3	3	6	Perradial . . . . . 1 1 1
				Interradial . . . . . 1 1 1
2	4	4	7	Perradial . . . . . 1 1 1 1
				Interradial . . . . . 0 1 1 1
13	4	4	9	Perradial . . . . . 2 1 1 1
				Interradial . . . . . 1 1 1 1
2	4	4	9	Perradial . . . . . 1 1 1 1
				Interradial . . . . . 2 1 1 1
1	4	4	10	Perradial . . . . . 2 2 1 1
				Interradial . . . . . 1 1 1 1
1	4	4	10	Perradial . . . . . 2 1 2 1
				Interradial . . . . . 1 1 1 1
1	4	4	10	Perradial . . . . . 1 1 1 1
				Interradial . . . . . 2 1 2 1
2	2	4	11	Perradial . . . . . 2 1 2 1
				Interradial . . . . . 2 1 1 1
2	4	4	12	Perradial . . . . . 2 2 2 2
				Interradial . . . . . 1 1 1 1
1	4	4	12	Perradial . . . . . 3 2 1 1
				Interradial . . . . . 2 1 1 1
1	6	6	11	Perradial . . . . . 0 1 1 1 1 1
				Interradial . . . . . 1 1 1 1 1 1
2	6	6	12	Perradial . . . . . 1 1 1 1 1 1
				Interradial . . . . . 1 1 1 1 1 1

I have frequently been able to confirm the observation of Bateson, (*op. cit.*), that where there are cases of marked difference in the size of the gonads of a given quadrant or of adjacent quadrants, that there is frequently a noticeable decrease in the size of the corresponding portion of the bell, as shown in Plate I, Fig. 5.

As compared with the variations occurring in other organs, particularly the marginal organs and canals, the per cent is extremely small, as will be seen at a glance in comparing the several tables. My observations on this point confirm those of both Bateson and Browne. The former found but 1.6 per cent, while the latter found it as large as 2.4 per cent. My observations gave the average of 2.75 per cent, as the total variations to be detected in *Aurelia flavidula*.

As already suggested in connection with Ehrenberg's observations, in which he claimed that variation reached 10 per cent, either this must be taken to include the total, in which case it is evidently too low, or if it refer to the vegetative organs alone it is certainly too high, unless indeed it may be possible that the *Aurelia aurita* of the Red Sea differs very greatly from the species in other waters, or from our own species.

### Rhopalia and Radial Canals.

An examination of the several tables will show that there is a general variation in the direction of an increase in the number of both rhopalia and radial canals. This has been shown to be the case in *Aurelia aurita* by both Ballowitz (*op. cit.*), and Browne (*op. cit.*). While confirming for the most part the results obtained by both these observers, there are points of difference which must be reviewed with some detail, and other points wherein I am unable to accept the conclusions of either in all particulars. Some of these will be considered in their appropriate connections.

Concerning the number of rhopalia little need be said further than to direct attention, as above, to the tabulated facts. A brief word or two in explanation of the Tables V to VII will suffice to render their meaning clear. Beginning with the first, or left hand column, there is listed the number of specimens having the characters given in the following columns. For example, in the second is given the number of gastric pouches, or lobes, in the third the number of oral lobes, in the fourth the number of rhopalia, and finally in the last the canal system not including the adradial system, since it bears for the most part, no direct relation to the rhopalia. The numbers following in each case refer to that of the rhopalia, and where less than the normal

number is given, as in the first line of Table V the fact in relation to the canals is shown by the 0, indicating their absence. Where a larger number than the normal is present, as in the fifth line and those following, the figure 2 in the perradial canals indicating that the extra rhopalium is perradially located. In other words, the figures in the columns under rhopalialia and canal system serve to show the correlation of the two sets of organs.

As indicated above, the tables give no account of the adradial canals, since normally they sustain no direct correlation with the

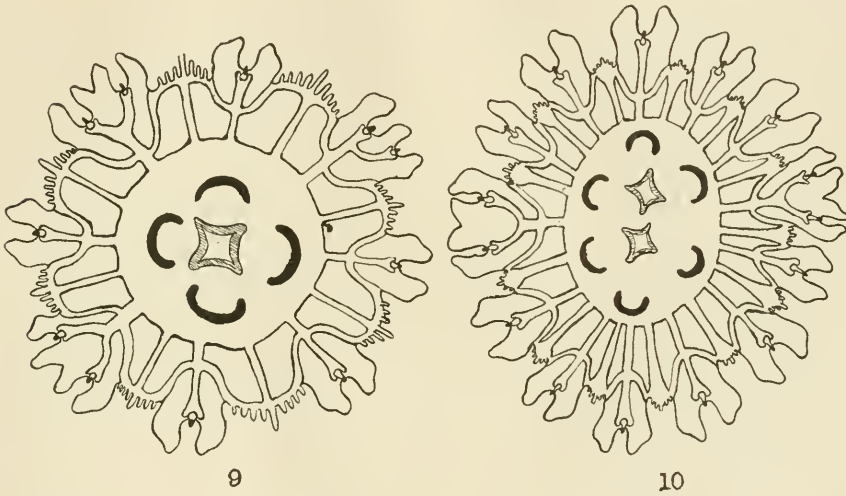

Fig. 9. Ephyra with three compound marginal lobes, quite comparable with those of Figs. 1 to 3.  
 Fig. 10. Ephyra with two mouths, and opposite compound marginal lobes.

other canals or with the rhopalialia. It must be said, however, that there are definite exceptions to this rule. And while not sufficiently numerous to call for tabulation along with the others, they occur in too many instances to warrant the somewhat ultra pronouncement of Browne ('01, p. 100) to the contrary. Whether a given canal shall be called adradial, interrarial, or perrarial depends not alone on its position or whether it be branched or otherwise, but upon both its position and relations to the other canals. The name signifies nothing in itself but that of relationship. There is no intrinsic reason why an adradial canal should

be unbranched, and as Browne admits in another connection (p. 101), there is good reason to believe that its position may shift considerably.

Figures 12, 14 and 15, are careful drawings of variant canal features, in each of which there is shown at *a* an adradial rhopalium, while in one case, Fig. 14, the canal is somewhat branched, but taken in its relations with both the other canals I see no other alternative than to regard it as adradial. This is also shown at *A*, Plate I, Fig. 2.

Both Ehrenberg and Ballowitz (*op. cit.*), have figured similar cases of undoubted adradial rhopalia.

The chief variations found in rhopalia are those of number and position, the later of which has just been noticed. The smallest number found was five, only a single specimen among the entire lot studied having so few. Six were found having but six rhopalia. Others having larger numbers are tabulated in their appropriate places in the various tables. As will be seen the largest number found was fifteen, and in but a single specimen. This specimen was further peculiar in having two fully developed and functional mouths, as shown in Fig. 10. This duplex oral condition served to give the animal a somewhat ovoid shape and at the same time a more or less bilateral aspect, the latter being further accentuated by the presence on almost exactly opposite sides of two compound marginal lobes and rhopalia, as shown in the figure.

A similar condition so far as the marginal lobes and rhopalia are concerned is shown in Fig. 9. In this case there are three compound lobes, but they do not tend in any way toward either bilateralism or even a trimerous form. An additional compound lobe would have rendered the variation a strikingly symmetrical one. But like the former and several others of a similar character which came under observation there was seldom exact symmetry.

The effect of less or more than the normal number of rhopalia may, or may not, disturb the general radial symmetry of the umbrella. For example, in Plate I, Fig. 1, is shown a medusa with but seven rhopalia, yet the general symmetry seems quite normal. By a careful inspection it is not difficult, however, to discover that one of the interradial systems is entirely lacking. Again in Plate I, Fig. 6, of a hexamerous specimen, there are



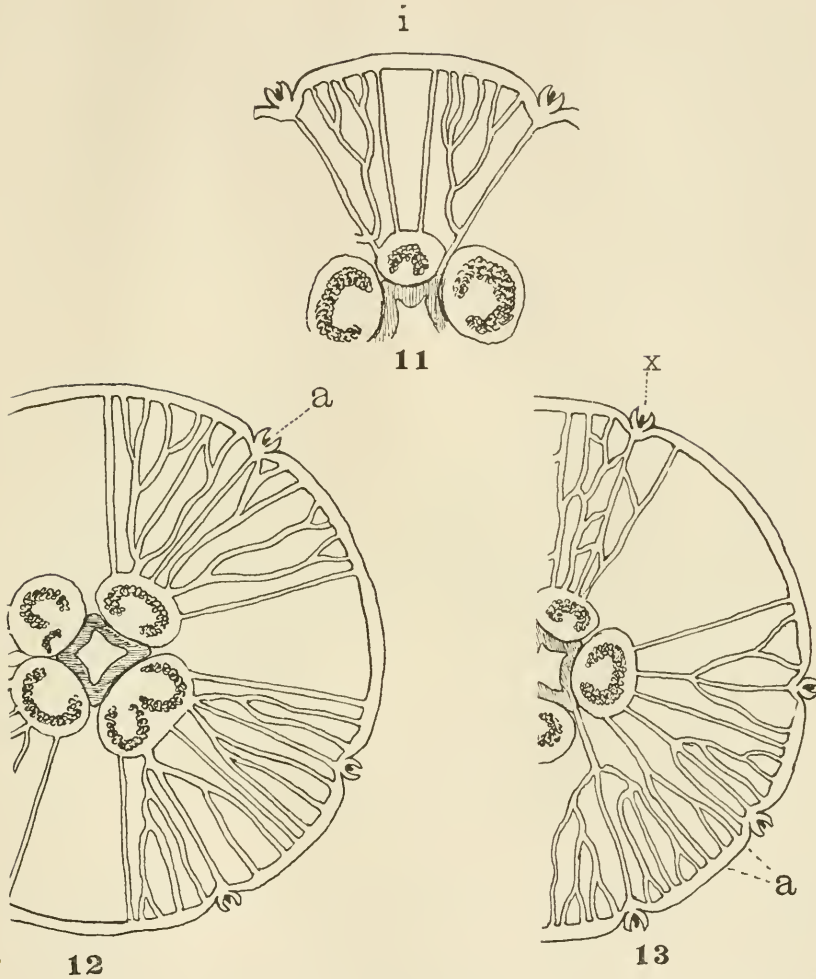

Fig. 11. Single octomere of adult medusa showing entire absence of the interradial canal, and the contiguity of two adradials.

Fig. 12. Diagram of medusa showing adradial rhopalium at *a* and lack of perradials in the octomeres drawn. Very small degenerate gonad in upper left hand pouch.

Fig. 13. Branched adradial canal at *a*, and at *x* the complete blending of the several canals of the segment into one system.

six gonads, six oral arms, and eleven rhopalia, the twelfth being absent and its perradial canal system likewise lacking, as shown at P, and still the general symmetry is hardly affected.

On the other hand, in several of the photographs, particularly Figs. 4 and 5, it will be seen at a glance that the symmetry is more or less seriously disturbed. In still others, while the general symmetry might not appear to be seriously affected, when attention is directed to the marginal symmetry it will be seen to have suffered quite definitely, in one case three rhopalia instead of one, occupying a single octant. In such a case, which is not rare

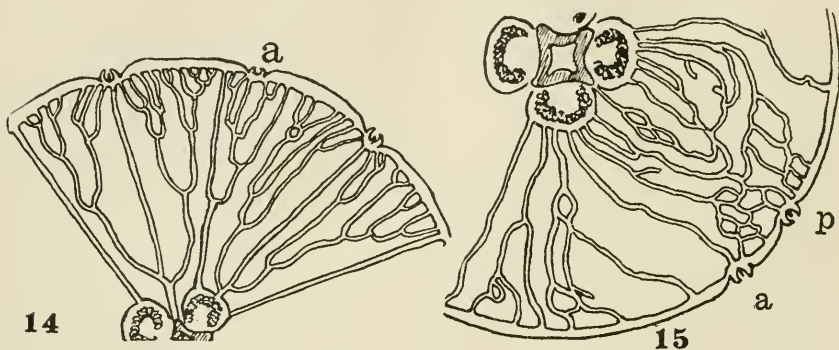

Fig. 14. Diagram showing a branched adradial canal and rhopodium shown at *a* sketched from Fig. 2 of plate.

Fig. 15. Diagram of the specimen shown in Plate I, Fig. 4, adradial canal and organ at *a*, perradial system at *p*, interradial absent or fused with the former.

the variation would seem to have been restricted wholly to that single segment, the other seven remaining normal.

And thus it is throughout; variations in one organ involving in many cases more or less distortion of the correlated organs, or even the entire organism. In other cases the variation has been associated with a regulative adjustment which has more or less served to maintain a fairly definite symmetry of both the immediate organs and the entire animal symmetry.

In connection with the study of ephyrae already given, attention was directed to the occurrence of twin rhopalia in several instances some of which are illustrated in several of the figures. Such double structures have been observed in adults, though unless

they be searched for critically they are seldom seen, since the hoods and lappets serve to screen them from ordinary observation.

It may be of some interest in this connection to refer to the occasional appearance of twin rhopalia in regeneration, an extended account of which I have elsewhere described.<sup>1</sup> It has been found that occasionally double rhopalia are produced in regeneration where originally there was only a single one which had been excised in the experiment. Rarely also during such experiments a super-

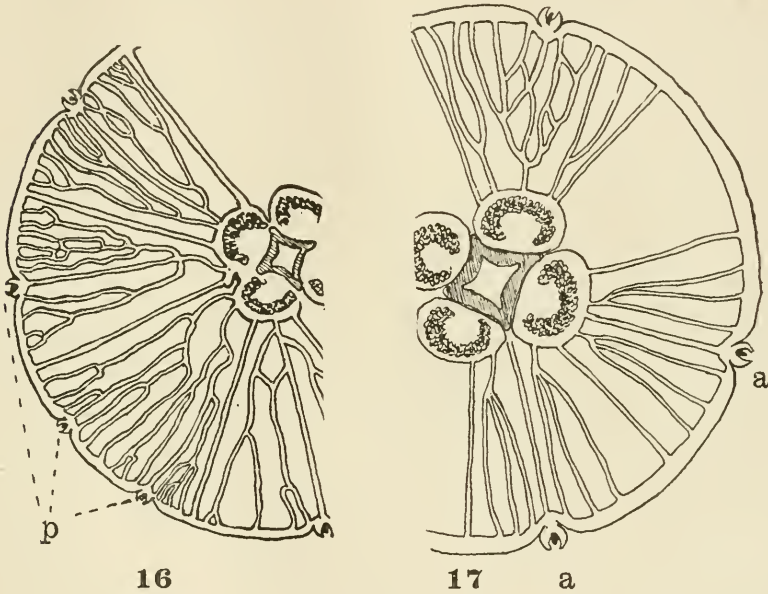

Fig. 16. Drawing showing three perradial canals and rhopalia in a given octomere, *p*.

Fig. 17. Sketch showing two octomeres *a, a*, with extremely simple canal systems. The positions of the rhopalia are adradial.

numerary rhopalium may develop at unusual points, as has been described in the paper just cited. It is not at all improbable, therefore, that in cases of injury the marginal portion of the umbrella involved may be more or less modified during the process of regeneration, and that marginal organs may appear in somewhat unusual places. It is not improbable that the somewhat anomalous appearance shown in Plate I, Fig. 4, may be due

<sup>1</sup>Regeneration in *Rhizostoma pulmo*. Jour. Exp. Zoöl., vol. i, p. 85.

to regeneration following a marginal injury. A close inspection of the notch just beyond the complex network of canals will reveal the presence of a small rhopalium, indistinct in the illustration, but very distinct in the specimen. To Browne's suggestion that the absence of a marginal body may be due to injury it will suffice to have called attention to the fact that these organs are promptly regenerated and therefore would not probably be long lacking in any case in which sufficient time had elapsed for the injury to heal.

Concerning variations in the canals of *Aurelia* it remains to call attention to some few points not hitherto considered. In several of the photographic figures are shown varying features of anastomosis among the canals, chiefly in the peripheral portions. In addition to the case just referred to others are shown in Figs. 1 and 6. In that of Fig. 1 is shown at various points the usual type of anastomosis, while in Fig. 6 of the hexamerous specimen is shown a most complicated type affecting only one-half of the umbrella. A few other cases are figured in the diagrams in which only a single segment may be involved.

This phenomenon of anastomosis I have found about as common in the small adults as in the larger, though Browne considers it as quite rare in small specimens. I have also found it frequently affecting the terminal portion of the adradial canals, especially in those rather rare cases in which the rhopalium is adradial.

The branching of the adradial canals has already been referred to in a brief way. It is only necessary to again call attention to the matter, and refer to several of the figures in which it is shown, *e. g.*, Figs. 13, *a*, and 14, *a*. An interesting and unusual condition is shown in Fig. 11, *i*, where the interradian system is wholly lacking and the two adradials thus brought into contiguous relations.

#### CYANEA AND DACTYLOMETRA.

Several incidental references have been made in the preceding pages to variations observed in ephyrae of *Cyanea*. It has long been well known that *Cyanea arctica* is a remarkably variable species, so much so that Professor Agassiz recognized some of them as distinct species, and described as such *Cyanea fulva*, and *Cyanea versicolor*. But the names have long since passed into the limbo of synonymy, the forms so designated not having even a varietal recognition. In the present instance, however, they may

serve to suggest the fact that the species varies greatly, but chiefly in the nonessentials of color and size, the southern forms being usually much smaller than those of more northern range.

In structural features I have found that this species exhibits very similar variations to those found in *Aurelia*. While it has not been within the scope of the present paper to enter upon any large survey of the problem as it relates to *Cyanea*, and no exact data have been accumulated, I have examined considerable numbers of both the ephyrae and adults, and find considerable variation in the number of rhopalia, the gastric and oral lobes, and the less important matter of coloration to which reference has been made above.

Similar observations have also been made upon our species of *Dactylometra*, and to the same effect. In general aspects it varies less than does *Cyanea*, as perhaps both vary less than does *Aurelia*, but concerning the fact of considerable variation there can be no doubt. In a paper upon the structure and development of *Dactylometra*, Mayer<sup>1</sup> has stated that the tertiary tentacles arise invariably on either side of the ocular lappets. While I have had no opportunity to examine any considerable number of these medusæ, I have nevertheless, found considerable disparity on this point. In several specimens examined in 1902 I found these tentacles arising at points intermediate between the primary and secondary series.

I have also found considerable variation in the number of the rhopalia and other marginal organs. Since, however, the data are too few to warrant any definite attempt at estimating the quantitative variations of either of these species, it must suffice merely to note the facts in a qualitative way and leave to another time, or other observer, the further consideration of details.

#### RHIZOSTOMA PULMO.

Among about fifty specimens of this medusa which I had occasion to examine critically in the progress of experiments upon regeneration, an account of which has been published elsewhere, and perhaps half as many others examined in the large aquaria less critically, about 15 per cent showed features of variation in

---

Bull. Mus. Comp. Zoöl., vol. xxxii.

one or more organs. Some of these it may be worth while to briefly consider in this connection.

As in the former series, the chief variations noted were those of the marginal organs, in which the range was from five, observed in two specimens, to twelve, found in only a single specimen; and in those of the vegetative organs—gonads, gastric and oral appendages. In these the variation was similar to the former series, though there was not close correlation, between the organs of the two series. There was, however, almost perfect correlation between the members of the same series. In other words, the gastric lobes and oral pendants were the same in number, and almost always of similar size. In a single case, and that a specimen having twelve marginal lobes and rhopalia, there was a perfect correlation of all the organs, including gastric and oral. In the usual crowding of the oral arms due to the large number present, two of these organs had been forced into the center of the group, the others forming a closely crowded circle about them. An incidental feature of two of the oral arms was that of the branching or bifurcation of the terminal portions. In the one case the lobes being unequal, while in the other they were quite uniform in size, though with the tips organically fused, or grown together. I have frequently found branched tentacles and oral arms, but it is unusual to find a subsequent union of the branches. It is rarely found in Hydra, and other hydroids, only a single case having come under my own observations.

Variations among the Rhizostomata have been recorded incidentally by several other observers, among whom are Haeckel,<sup>1</sup> Keller<sup>2</sup> and Lendenfeld.<sup>3</sup> The latter has given much more critical attention to the details of the problem than either of the former. This is, however, in relation to the larval, or ephyra history rather than to that of the adult. Indeed, concerning the adult this observer has recorded but a single case among many specimens of *Crambressa mosaica*. Among specimens of *Phyllorhiza punctata* he records having noted those with more than the normal number of marginal bodies, but believes these supernumerary organs to have been a result of abnormal growth following injury.

---

<sup>1</sup>Haeckel, E., *Das System der Medusen*, 1879.

<sup>2</sup>Keller, C., *Zeits. f. wiss. Zoöl.*, Bd. xxxviii, S. 641.

<sup>3</sup>Lendenfeld, R. von., *ibid.*, Bd. xlvii, S. 260, *et seq.*

His most remarkable observations are concerned with the marginal lobes and sensory bodies of the ephyræ. He finds these to vary in number from eight, the normal, to twenty-four. While this extreme of variation is large it is not, however, improbable. The most remarkable feature of the case is the interpretation which Lendenfeld gives. He claims that during metamorphosis these larvæ pass from the ordinary condition of octamerism through stages of, first twenty-four, later sixteen and finally emerge to the adult stage with the normal eight-merous condition. "So habe ich gefunden, dass die Ephyren von *Phyllorhiza punctata* acht, spätere Stadien vierundzwanzig, noch spätere sechzehn und endlich die ausgebildeten Medusen wieder bloss acht Randkörper besitzen."

Though it is not expressly claimed that these phenomena are involved in the observed ontogeny of these medusæ, it is nevertheless, clearly implied. If this inference be correct then the results must be accepted unless other observations may serve to discredit the account given. If, on the other hand, as I am strongly inclined to believe, these several stages have been observed in connection with the general phases of metamorphosis such as one might find among a given series of larvæ, then the conclusion I should incline to draw is that these phenomena are but larval variations similar to those described in the earlier portions of this paper. Moreover, when we are farther advised that these peculiar variations are due to injuries the suspicion is still greater that the observed variations are not normal processes during metamorphosis, but in fact, true variations as above suggested.

Furthermore, my own experiments upon regeneration in *Rhizostoma* (*op. cit.*), would seem to preclude the factor of injury as of any importance in relation to variation. In these experiments there was not the slightest evidence to support the view proposed by Lendenfeld. We may, therefore, accept these instances as but further extension of our knowledge of the wide prevalence of variation among the Scyphomedusæ, which the more critical attention given to the subject during the past few years has brought to light.

#### FOSSIL MEDUSÆ.

It will not be without interest in this connection to call attention to the occurrence of variations among fossil medusæ. In a recent

monograph on "Fossil Medusæ" Walcott<sup>1</sup> has described a large number of fossil medusæ, among which several cases of remarkable variation are recorded. In some the variation was so general as to render difficult specific diagnosis. For example, in the description of *Brooksella alternata* the author says: "The variation is so great in this species that a brief diagnosis is of little value." . . . "The umbrella lobes vary in number from 6 to 20 or more, and in form from broad, slightly rounded to narrow and strongly rounded. There is no regular sequence of 6, 8, 12, etc., on the contrary the irregular numbers 5 and 7 are largely represented, and 6 and 8 are abundant."

Again in his description of *Laotiara cambria* he says: "Its variations are greater than in *Brooksella*." The lobation of the exumbrella is from the simple four-lobed variety, through series of 5, 6, 7, to 8 or more, to what he designates as the compound type, which are apparently medusæ in process of fission. In this species, as in the preceding, there seems to be no definite regularity or sequence in numerical order. In the words of the author: "In many individuals there is no regularity, and in the extreme forms there is an irregular network of subumbrella lobes and oral arms."

From the numerous figures of this well-illustrated monograph it is quite evident that similar, if not equally extensive variation is also present in many other of the species described. It is not, however, within the scope of this paper to undertake an extensive review of the entire subject, and hence further details concerning this phase will not be submitted. Citation of the foregoing facts may serve to direct attention of those interested to a phase of the general problem hitherto little considered.

#### INFLUENCE OF ENVIRONMENT ON VARIATION.

As is well known, there is a more or less currently accepted belief in the influence of environment as a modifying factor in the variation of organisms. Reference has already been made to Haeckel's views as to the influence of such factors in relation to the abnormalities arising in medusæ reared under artificial conditions, and to his further suggestions concerning the probable influences of similar conditions in nature.

<sup>1</sup>Mono. Unit. States Geol. Surv., vol. xxx, Wash., 1898.



It was with these in mind that in securing material for my investigations I endeavored to have it collected from points somewhat remote, yet in the same general region, and also from environments so definite and yet distinctly different, as to afford a means of estimating the probable effects traceable to direct and determining factors. It was an unexpected bit of good fortune that brought me into possession of material from an environment apparently quite likely to afford just the desired conditions suitable to a test. This was the occurrence of ephyræ of *Aurelia* in considerable numbers in April, 1902, in a small more or less isolated, and polluted pool, known at the "eel pond" located at Woods Hole, and connected with the waters of the harbor by a very small inlet, sufficient to admit tide-water daily. The pond has served in some measure as a general dumping ground for various waste and sewage from the village.

From this pond I obtained 486 ephyræ, all quite young, and many of which I was able to examine alive soon after their capture. A few specimens were obtained from strobilating polyps kept in aquaria where they thrived quite well for several weeks.

A second series was obtained from Waquoit Bay, a large bay opening directly into Vineyard Sound, and some ten miles east of Woods Hole. This collection was made in April 1901, and contained 1026 specimens.

Still a third series was collected at Waquoit in 1904, numbering about 1000. They were obtained in May, and were mostly in process of metamorphosis into young medusæ.

In 1905 a collection of adults were obtained from somewhat similar environments, one series, indeed, from Waquoit. The other numbering about 200—though on account of poor preservation only 129 were available for accurate study—were collected at the mouth of the Acushnet River, in New Bedford harbor. This environment was as unlike that of Waquoit as is the latter from the "eel pond." New Bedford harbor receives the sewage and other pollution of the city, as well as the constant influx of fresh water from the river, thus constituting an environment at once more or less local and peculiar, being about 17 miles west of Woods Hole and therefore nearly thirty miles from Waquoit.

Observations made upon the ephyræ of *Cyanea* during their development, a brief account of which has been given elsewhere, in which considerable variation was discovered and found to be

due in some measure to the artificial conditions under which they were reared, led me to anticipate similar results in ephyrae obtained from an environment like the "eel pond." In this, however, I was somewhat disappointed. For while the ratio of variation found was somewhat larger than that in either of the series from Waquoit, as will be seen by a comparison of the tables, still it was far less than had been anticipated. The total number found among the 486 specimens taken in the eel pond which showed variant features was 144, or 29.6 per cent.

In the collections from Waquoit the series of 1901 comprising 1026 specimens the variants were 24.9 per cent; of the series of 1904, the 218 ephyrae showed 22.9 per cent of variants.

While the difference in favor of the eel pond series is appreciable, it is still small, too small indeed, to warrant a final conclusion as to the influence of any given factor as a determining condition. Again, it must not be overlooked that the number of specimens under consideration was likewise comparatively small.

Moreover, when we come to compare the data obtained relative to series of adults the uncertainty is greatly accentuated. Comparing the data of Table VI with those of Table VII, wherein are shown the several features of variation, it will be seen that those from the New Bedford environment, within which they were doubtless bred and reared, have a lower per cent than those from Waquoit, the exact figures of the two being 22.5 per cent for the former, and 24.3 per cent for the latter.

Therefore when a careful analysis of the available data is made we are compelled to admit that the evidence concerning the influence of environment so far as the present organisms are concerned is not convincing. And until further and more extended comparisons can be made in these or similar circumstances the answer to the general problem must be regarded as negative.

#### SIGNIFICANCE OF THE VARIATIONS IN RELATION TO NATURAL SELECTION.

From the foregoing review of the history of variation as it pertains to *Aurelia* in particular, and to a less extent to other Scyphomedusæ also, it must be quite evident that the phenomena are numerous and involve almost every part of the organism. Furthermore, so far as *Aurelia* is concerned, variations have been

more or less continuous from the earliest records of von Baer and Ehrenberg to the present time precluding any probability of the operation of simply incidental factors.

An inspection of the tabulated records of more recent times will show that the tendency has been constantly toward a more or less definite increase of the several organs, particularly the marginal or sensory, though including also the central or vegetative. If one had taken occasion to construct a curve representing the various phases it would have shown that the variations had been preponderatingly upon one side of the modal line. In the absence of the curve it may facilitate a ready appreciation of the situation to submit percentage values of the variations above and below the normal.

Results obtained by Browne covering a period of about five years and including an examination of several thousands of specimens presented in percentage figures are as follows:

	NORMAL.	ABOVE NORMAL.	BELOW NORMAL.
Rhopalia .....	78.71 per cent.	16.74 per cent.	4.55 per cent.
Vegetative.....	97.6 per cent.	1.8 per cent.	0.6 per cent.

Results obtained by my own observations covering a period of four years and an examination of about 2500 specimens are as follows:

	NORMAL.	ABOVE NORMAL.	BELOW NORMAL.
Rhopalia .....	75.07 per cent.	22.97 per cent.	1.96 per cent.
Vegetative.....	97.24 per cent.	2.2 per cent.	0.56 per cent.

The significance of this line of rather definite and continuous variation is somewhat doubtful. Without specific details in the work of Baer and Ehrenberg it is impossible to formulate conclusions as to the ratio of variation in *Aurelia aurita* as observed by them, but the more recent observations of Bateson, Browne, Ballowitz and those herein described, make it perfectly certain that for at least two species of medusæ from widely separated regions variation has been remarkably active and continuous. But at the same time it seems equally certain that so far as one is able to see there has been no evidence of the operation of anything like natural selection at work. The variant forms do not appear to be more numerous than formerly, nor does the variation seem to be appreciably larger in one species than in the other, if

indeed we really have in *Aurelia aurita* and *Aurelia flavidula* definitely distinct species, a query which has frequently forced itself upon my attention during the present research.

In this connection has naturally arisen the question as to the operation of any process akin to mutation. Mayer<sup>1</sup> in a recent paper on "The Variations of a Newly Arisen Species of Medusa," p. 4, reviewing the variations in *Aurelia* remarks: "It is evident that symmetrical "sports," or discontinuous variations of *Aurelia*, are continually being produced, and yet the form of the species as a whole remains unchanged."

I have previously discussed the matter of the *symmetry* of these variations, and need not take it up again, further than to say that it seems to me unfortunate to contend for the dominance of the idea of symmetry in the sense referred to, and that so far as it appears to me there is little in these variations which can be regarded as "discontinuous," or mutative. They seem on the contrary to be definitely *continuous*, and somewhat of the nature of fluctuating variations. Browne's suggestion (*op. cit.*, p. 100), that "if a very slow and gradual change is taking place in the number of tentaculocysts, then the tendency is toward the establishment of a race with ten tentaculocysts, due to an increase of two opposite perradial tentaculocysts," hardly seems warranted from the facts as known. I can hardly see that there is any such predetermined variation as would be called for by his suggestion.

So far as I am aware, the only case of variation among medusæ which might seem to be of the nature of mutation is that of *Pseudoclytia pentata*, Mayer (*op. cit.*). Of this case we have only the records of a single series of observations. Whether subsequent evidence will clearly confirm Mayer's conclusions remains to be seen. Furthermore, the results would have to be followed through several generations of medusæ in order to clearly establish the case as one of definite mutation, and this the future must determine.

---

<sup>1</sup>Mayer: The Variations of a Newly Arisen Species of Medusa. Bull. Mus. Brooklyn Inst. Arts and Sciences, vol. i, 1901.



## EXPLANATION OF PLATE.

All figures were photographed natural size directly from nature.

Fig. 1. At I is shown the missing segment, of an otherwise normal specimen. Toward the periphery may be seen typical anastomoses of the radial canals.

Fig. 2. Medusa with nine rhopalia, the extra one at A occupying an adradial position, at the terminus of an adradial canal, unusual in its terminal branching.

Fig. 3. Medusa with ten rhopalia, the two extra ones occupying the same perradial segment, at P.

Fig. 4. Medusa with only seven rhopalia, one at A being at the terminus of the much curved adradial canal. At P is shown, at the margin of a complex perradial segment, a very small rhopalium. The interradial rhopalium is lacking in the adjacent segment to the left.

Fig. 5. Medusa having but three oral lobes, which were excised before the photograph was made, two of the gonads much smaller, and the umbrella of that side also appreciably narrower.

Fig. 6. Hexamerous medusæ, having eleven rhopalia, the twelfth at P with the entire perradial system of that segment lacking. On the lower right-hand side may be seen the very complex anastomoses of the canal systems of that region.

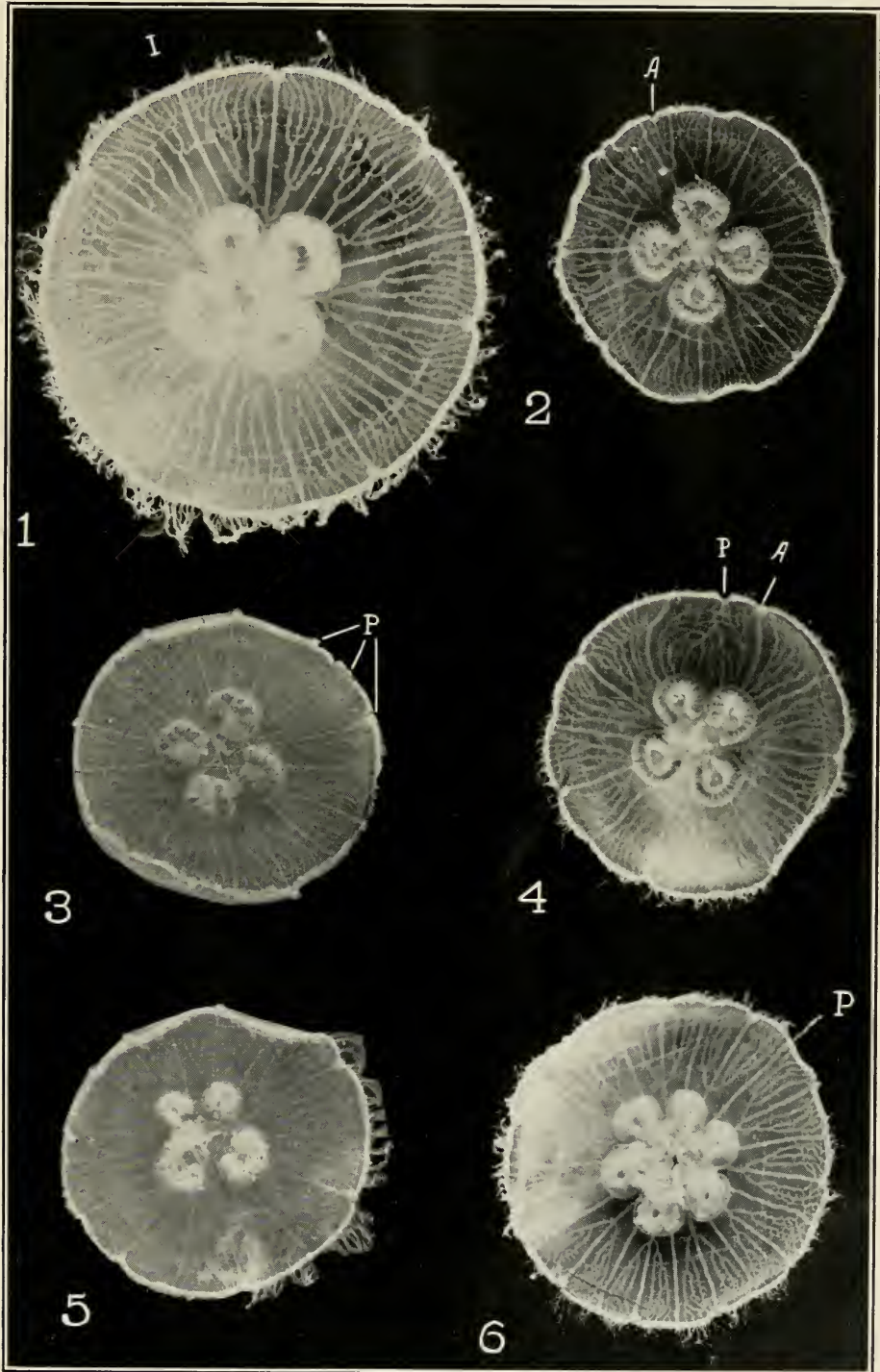





# AN EXPERIMENTAL STUDY ON THE LIFE-HISTORY OF HYPOTRICHOUS INFUSORIA.<sup>1</sup>

BY

LORANDE LOSS WOODRUFF.

WITH 3 PLATES AND 12 FIGURES IN THE TEXT.

I. Introduction.....	585
II. General Methods and Technique.....	587
III. Description of the Cultures.....	590
1. <i>Oxytricha fallax</i> , Culture A.....	590
2. <i>Oxytricha fallax</i> , Culture B.....	594
3. <i>Pleurotricha lanceolata</i> , Culture A.....	594
4. <i>Pleurotricha lanceolata</i> , Culture B.....	596
5. <i>Gastrostyla steinii</i> , Culture A.....	596
IV. Discussion of the Data of the Cultures.....	601
1. Rhythmical and Cyclical Variation in the Rate of Division.....	601
2. Artificial Rejuvenescence.....	605
3. Conjugation.....	606
V. Physiological and Morphological Variation during the Life-cycle.....	607
1. Physiological Variation.....	607
2. Morphological Variation.....	608
VI. Effect of Initial and Daily Stimulation with Salts on the Rate of Division.....	614
1. Potassium Phosphate (Monobasic and Dibasic).....	615
2. Potassium Chlorid and Sodium Chlorid.....	620
3. Potassium Sulphate and Magnesium Sulphate.....	621
4. Potassium Bromid.....	622
5. Comparison of Results.....	622
VII. Effect of Light on the Rate of Division.....	625
VIII. Summary.....	626

## I. INTRODUCTION.

The first suggestion of the cyclical character of the life-history of Infusoria was advanced by Dujardin as an argument against Ehrenberg's theory that the Protozoa, because of their simple organization and method of reproduction, are not subject to natural death. The observations of Bütschli ('76) and Engel-

---

<sup>1</sup>Submitted in partial fulfilment of the requirements for the degree of Doctor of Philosophy, in the Faculty of Pure Science, Columbia University.

mann ('76), that in infusorian cultures after a number of generations the organisms are reduced in size and show other signs of degeneration, were evidence in favor of Dujardin's theory. As is well known, however, Weismann ('84) greatly elaborated the theory of the potential immortality of unicellular organisms, maintaining, on *a priori* grounds, that the Protozoa, like the germ-cells of higher forms, are not subject to natural death. Maupas ('88; '89) in his classic researches on the life-history of Infusoria brought forward data which weighed heavily against Weismann's hypothesis. In his long-continued cultures he found marked evidence of "senile degeneration" and he confirmed the general conclusion of earlier workers as to the cyclical character of the life-history of certain species. More recently still Joukowsky ('98) and Simpson ('01) have investigated the life-histories of various forms, and Calkins ('02, 1, 2, 3; '04, 1) in a series of papers on *Paramœcium* has submitted strong evidence that this species passes through more or less regular periods of vigor and weakness, the periods of weakness invariably ending in the death of the culture unless the organisms are "stimulated" by conjugation or by changed environment. This work, besides throwing light on the rôle of conjugation in the life-cycle, gave the first experimental proof that various stimuli will "rejuvenate" the lagging functions of exhausted protoplasm and incite the *Paramœcia* to further periods of reproductive activity.

In the light of the previous investigations on the physiology of Infusoria, the following questions seem to be of sufficient importance to warrant still more extensive experimental work on different forms, in order to place the problems involved on a broader foundation:

1. Does the life-history of Infusoria, in general, run in cycles?
2. If so, will changes in the environment bring about renewed activity during depression-periods?
3. Will conjugation effect "rejuvenation"?
4. What are the physiological and morphological changes, if any, characteristic of declining vitality?
5. What effect has initial and daily application of various stimuli on the division-rate, *i. e.*, on the metabolic activity of protoplasm?
6. Is the division-rate affected by light?

The present investigation is an attempt to answer these ques-

tions as far as possible for hypotrichous Infusoria. With this in mind, experiments on five cultures of hypotrichous Ciliata, including *Oxytricha fallax*, *Pleurotricha lanceolata*, and *Gastrostyla steinii*, have been carried on during the last three years. Anticipating the conclusions, it may be stated briefly that the experiments offer affirmative evidence upon the first two points and negative evidence upon the last, while owing to failure of the infusorians to conjugate there is no evidence upon the third point. Regarding the fourth and fifth points, it may be said that morphological changes, particularly such as concern the cytoplasmic and macronuclear structures, are characteristic of declining vitality, and that initial and daily stimuli have a marked effect upon the metabolic activities of the forms studied.

I take pleasure in acknowledging my great indebtedness to Professor Gary N. Calkins, at whose suggestion this investigation was undertaken, for his advice and criticism throughout its prosecution. I also wish to express my thanks to Professor Edmund B. Wilson for many helpful suggestions.

## II. GENERAL METHODS AND TECHNIQUE.

In the experiments on Protozoa here described, which have been followed continuously for the past three years, I have employed, with but slight change, the method used by Calkins ('02, 1) which is itself an improvement on the method of Maupas. As this method is described in detail by Calkins, a brief outline of it with my own modifications will suffice.

The organisms were cultivated on slides having a central circular concavity with a capacity of about five drops of water. Cover-glasses, used by Maupas and Calkins, were not employed, as it seemed to me that a more natural condition was obtained without them, and as I found that unless great care was exercised in cleaning the slips they afforded a possible source of contamination. The slides were kept in moist chambers to prevent evaporation of the preparations. These were ordinary stender dishes about ten inches in diameter and three inches deep. In the bottom of the dish was placed about two inches of wet sand. Over the sand was placed a glass plate on which rested four parallel strips of glass and on these the depression slides with the Protozoa were arranged. The whole was covered with a ground-glass top.

The Infusoria were handled with a pipet drawn out to a fine point. Each pipet was used for one purpose and only one. All of the Infusoria employed are of sufficient size to be seen readily with a lens having a magnification of about ten diameters, and as it is far more easy to operate with this than with a compound microscope, it was used almost entirely in transferring specimens with the pipet from one slide to another.

At first hay-infusion was employed as a culture-medium, but later it was found that an infusion of fresh grass gave equally good results and had the advantage that one kind of grass could be selected and used to the exclusion of all others, thus securing a more uniform culture-medium. The infusions were prepared as follows: About three grams of grass or hay was washed in tap-water and then placed in a beaker containing about 200 cc. of tap-water; this was boiled for one minute. In most cases this infusion was used shortly after it had cooled but occasionally it was allowed to stand for twenty-four hours. Except at certain periods of physiological depression and during certain experiments, to be described, this type of culture-medium was used throughout the work.

As pointed out by Bütschli and Calkins, Maupas's method was inaccurate in that he assumed the rate of division of all individuals of a culture to be the same and allowed a large number of specimens to accumulate before computing the number of bipartitions. Protozoa, like all other animals, have their individual physiological peculiarities, as is shown by my own and similar experiments. In order to obviate this source of error as far as possible and to exclude the possibility of endogamous conjugation occurring in the direct line of the culture, one individual from each line of the culture was isolated almost every day. In the great majority of cases not more than four individuals, representing two generations, were present at the time of transference. At each isolation the single infusorian was put in fresh culture medium, the remainder being kept as a reserve, or "stock," in case, through accident or otherwise, the individual isolated did not live.

Following the earlier workers, the maximum and minimum temperature of the laboratory in the vicinity of the cultures, as recorded by a registering thermometer, was noted daily. This is, of course, but a rough method as the temperature within the moist chambers is more constant than in the room itself; still, it

gives the greatest variation which could possibly occur, and by averaging the maximum and minimum points of each day for ten-day periods the result is quite satisfactory for comparative work.

For the purpose of following as closely as possible the changes in cell structure during the life of the cultures, permanent preparations of individuals from different lines were made from time to time. Here again I employed with little change the method used by Calkins, which is briefly as follows: The specimen to be preserved is isolated by means of a fine-pointed pipet on a clean depression slide (which is kept just for this purpose) with as little of the culture-medium as possible. To this is added three or four drops of bichlorid of mercury in saturated solution with 5 per cent of glacial acetic acid. After about five minutes the specimen is transferred to another slide and a few drops of 75 per cent alcohol is added. A slide is now smeared with a trace of egg-albumin and the specimen is taken from the 75 per cent alcohol and gently spurted onto the albumin. After a short time, when the alcohol has coagulated the albumin, the slide with the specimen adhering to it is transferred to a jar of 75 per cent alcohol and is thereafter treated by the ordinary slide method.

For staining, Ranvier's picrocarmin was used, although Delafield's hematoxylin gives quite satisfactory preparations. Clearing was done with xylol, and damar was used in mounting.

For convenience in description the main cultures are designated by letters, and the individual lines (four in number) which make up each of these cultures are designated by figures. Thus, the two cultures of *Oxytricha fallax* are designated respectively A and B, and the lines under them as A-1, A-2, A-3, A-4, and B-1, B-2, B-3, B-4. In each case the culture was started by isolating one wild individual and when this had divided twice, giving four individuals, these were isolated to start the four lines. These four lines thereafter were kept distinct except in cases where one died out through accident or through the isolation of a weak individual, in which case its place was supplied by a specimen from one of the three closely related lines. Of course, the more lines of a culture that are carried on, the closer their average rate of division will approach the true one for the culture. I have found that four lines is all that can be reasonably carried without undue labor and the average here is probably near enough to give

the general result. Throughout this work, as in that of my predecessors, the rate of cell-division is taken as the indication of the physiological status of the cultures; it being generally accepted that this is a just criterion of metabolic activity.

The experiments were started in the Zoölogical Laboratory of Columbia University, New York City, and carried on there continuously (except for a short period during the summer months) during the first two years of the work. The last year of the work was done at the Thompson Biological Laboratory of Williams College, Williamstown, Massachusetts.

### III. DESCRIPTION OF THE CULTURES.

#### 1. *Oxytricha fallax*, Culture A.

On October 26, 1901, a specimen of *Oxytricha fallax* was found in an aquarium, in the Columbia laboratory, containing water and superficial slime taken a few weeks before from a stagnant pond at Van Cortlandt Park, New York City. The individual was isolated on a depression slide in a few drops of hay-infusion as previously described. Two days later the infusorian having divided twice, each of the four individuals was transferred to a separate slide, thus starting the four lines of Culture A which are designated respectively A-1, A-2, A-3, and A-4. The accompanying diagram shows the daily record of divisions of all four lines averaged together and this again averaged for each ten-day period of the life of the culture.

As is indicated in the diagram, the culture started with an average rate of a little over one division per day for the first ten-day period. This was increased to one and three-quarters divisions for the second ten-day period, after which there were two periods in which the rate fell each time below that of the first period, *i. e.*, in period four to exactly one division per day.<sup>1</sup>

<sup>1</sup>From November 20 to 24, in the third period, A-1 and A-2 were changed from the hay-infusion to a medium of flour and water, prepared by boiling a pinch of flour in about 25 cc. of tap-water for fifteen minutes. This was used about an hour after cooling. This change of medium was made because I became alarmed at the rapid fall in the division-rate—not having become acquainted, as yet, with the general life-cycle of hypotrichous forms. That the use of the flour had no apparent effect was shown by a comparison with the division-rate of A-3 and A-4 which were continued on the hay-infusion diet.

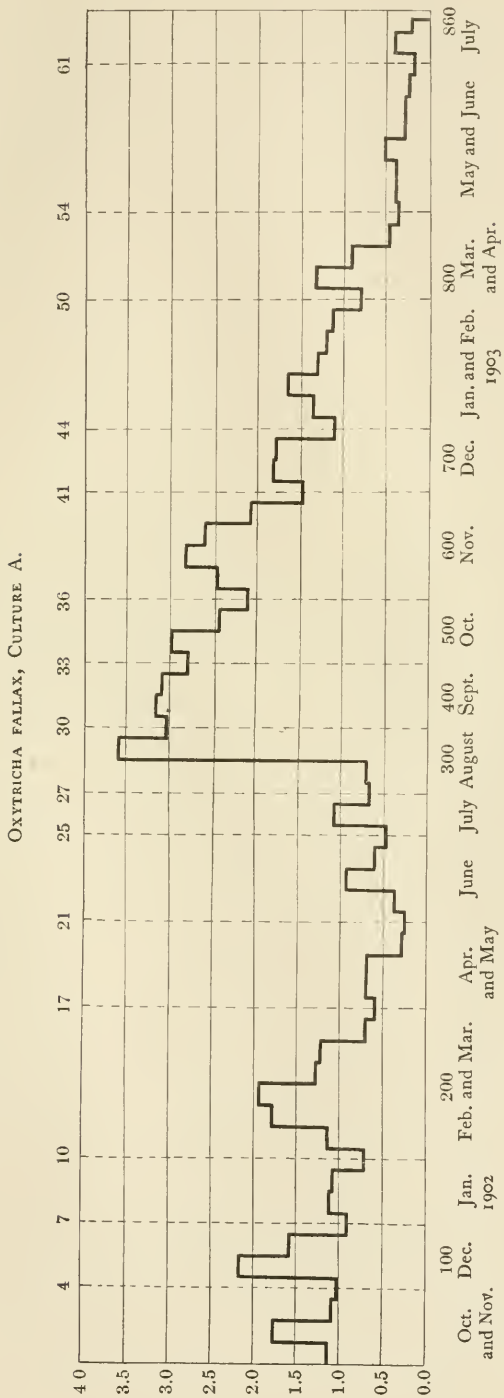

DIAGRAM I.

Complete history of *Oxytricha fallax*, Culture A, from start (October 26, 1901) to extinction (July 14, 1903) in the 86th generation. Rate of division averaged for ten-day periods. The ordinates represent the average daily rate of division of the four lines of the culture. The broken lines designate the limits of the various rhythms. Above, the numbers of the ten-day periods which limit the rhythms are indicated; below, the months in which the rhythms chiefly fell. The figures, 100, 200, etc., represent generations and are placed in the periods in which they were attained.

During period five there was a marked rise for no apparent cause to over two and one-eighth divisions, and then a fall to about seven-eighths of a division per day in the seventh period, which was below the lowest rate so far attained by the culture. The next fall, however, was still lower, when seven-tenths of a division per day was recorded. After this there was another rising period extending over about a month and attaining a maximum rate of nearly two divisions. From here there was a gradual decline for four periods when a minimum of six-tenths of a bipartition per day was averaged—the lowest point so far attained. Again a slight rise for twenty days, and then a fall at the twenty-first period (210 days since the culture was started) to one-quarter of a division per day, the lowest point reached in the division-rate, which had been gradually diminishing since the beginning.

It was apparent that unless something was done to stay this decline or “rejuvenate” the culture at this point that it would soon die out. Calkins had succeeded in reviving *Paramœcium* cultures with an extract of beef, and acting on this clue all four lines were transferred to weak beef-extract<sup>1</sup> for five days and then changed back to the regular hay-infusion diet. As the beef-extract showed no immediate results, flour and water was tried again, apparently to no purpose. I now returned to beef-extract, this time making it stronger and varying the strength from day to day, and this treatment was continued up to June 1. This time a very slight rise in the division-rate for the period occurred (*cf.* Diagram I, period 22) and during the following ten days it increased to almost one division per day. Then it fell again for two periods, but the slowest rate here attained was considerably faster than the previous low mark of period 21. In period 26 the diagram shows a considerable rise which was brought about by a sudden springing into activity of one line (A-I) of the culture. Instead of dividing at the rate of about once in two days, it started off on July 7 at the rate of three times per day. When I first noted this sudden change I thought that possibly in some way, in spite of all precautions, an adventitious specimen, perhaps as a cyst, had

---

<sup>1</sup>The beef-extract was made by boiling for a few minutes a piece of lean beef about the size of a silver half-dollar in 200 cc. of tap-water. This was allowed to settle for a number of hours and then the clear extract was used.



vitiating the culture, and I immediately examined the stock of the line—some of which had not been touched for a number of days. I found that this also had started dividing at the same rapid rate, and as there was apparently no way in which all the preparations could have become contaminated simultaneously, I was convinced that the increase in rate was due to some change in the culture itself—a conviction which was substantiated by a study of the cytological changes in the permanent preparations; but to leave no chance for error I removed the rapid line (A-1) to another moist-chamber and thus isolated it from all the rest. This condition of affairs—A-1 dividing about three times each day and the other lines once in two days—continued for just a month when the three other lines sprang into activity. This at once, of course, brought up the average of the four lines as is seen in the twenty-ninth period (Diagram I) when the average rate of multiplication reached over three and one-half divisions per day. This twenty-ninth period was the high record for the division-rate of this culture. During the next ten days the rate fell to three divisions per day; then occurred a slight rise above this for twenty days, and then another drop to about two and three-quarters divisions per day for the thirty-third period. This rising and falling of the division-rate continued to the very end of the life of the culture, or from August, 1902, to July, 1903, nearly a year.

At the fifty-third period it was clear that the culture was again approaching extinction and, accordingly, two lines, A-1 and A-2, were transferred for a day to beef-extract, leaving A-3 and A-4 in the normal hay-infusion. This had no visible effect on the lines treated and both died out at different times, and their places were supplied by individuals from the other two lines.

During period 54 the culture medium for all lines was changed from hay-infusion to an infusion made with fresh grass in order to see what effect a change in medium would have on the behavior of the culture. The very slight rise in the division-rate which followed for the next three periods may be due to this change, but I think it is more probable that it is due to a decided rise in temperature which took place at this time (*cf.* Diagram VII). During the next two periods no attempt was made to revive the culture, and as the fission-rate remained quite uniform I postponed all experiments in order to see what would take place if the culture was

allowed to run its natural course. A very slight falling of the division-rate occurred in the next twenty days; but in the ten-day period after that there was a more decided rise than had taken place for a long while. This proved to be only temporary for the Infusoria suddenly began to die off and within four days only six specimens were left. Efforts to stimulate by artificial means ( $K_2HPO_4$ , return to the usual hay-infusion, etc.) were unavailing, and the last individual died on July 14, in the 860th generation—626 days after the first isolation.

### 2. *Oxytricha fallax*, Culture B.

A second culture of *Oxytricha fallax* was started on December 10, 1902, with an individual found in a hay-infusion, made with boiled water, in the Columbia laboratory. The method of procedure was the same as that already described for the A-culture. The accompanying diagram shows the history of the fission-rate of all four lines averaged together and this again averaged for each ten-day period of the life of the culture.

Culture B was continued for a period of 348 days during which time it attained 429 generations. Its loss was due entirely to an accident resulting in the drying up of the preparations. The general rate of division for the first twenty-three periods averages about one and one-half divisions per day, and compared with the curve of Culture A, the curve of B is considerably more uniform. From period 24 on (August), however, the rate shows a considerable falling off and it was averaging about one division in two days—the lowest rate in its history—at the time that the culture was lost.

### 3. *Pleurotricha lanceolata*, Culture A.

A culture of *Pleurotricha lanceolata* was started November 10, 1902, with an individual from an aquarium in the laboratory of Columbia University which contained material collected during the previous month at Fort Lee, New Jersey. The treatment of the culture was the same as that already described for the *Oxytricha* cultures. The general trend of the division-rate, as shown by Diagram III, was steadily downward from the beginning to the nineteenth period (May), when the low rate of one division in eight days was reached. During the next three periods a marked

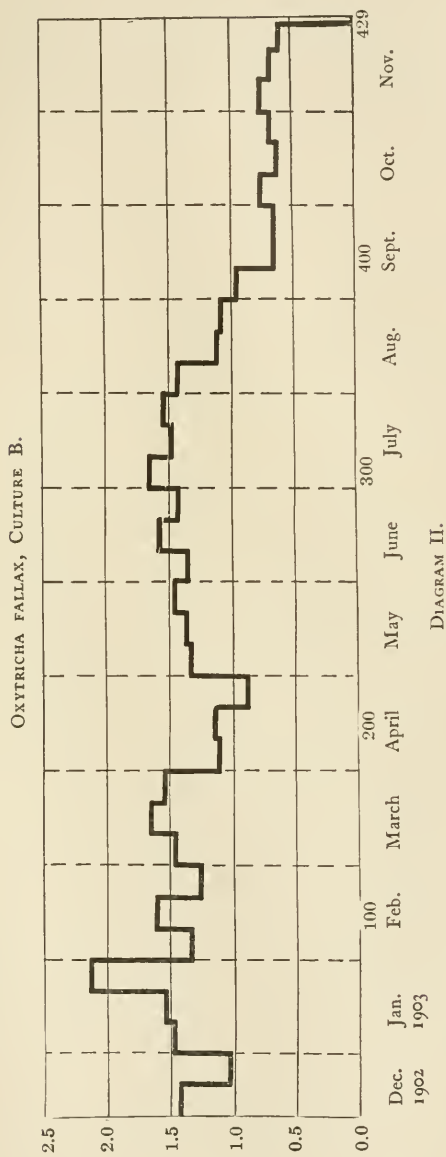

Complete history of *Oxytricha fallax*, Culture B, from start (December 16, 1902) to finish (November 22, 1903). The broken lines indicate the limits of the various months over which the culture extended. The other details are the same as for Diagram I.

rise took place for which there is no apparent cause, but this recovery was not lasting and the rate fell somewhat during the next period, while in the period following this all the infusorians encysted, thus bringing the culture to an end at the two-hundredth generation, and after being under observation for two hundred and thirty-five days.

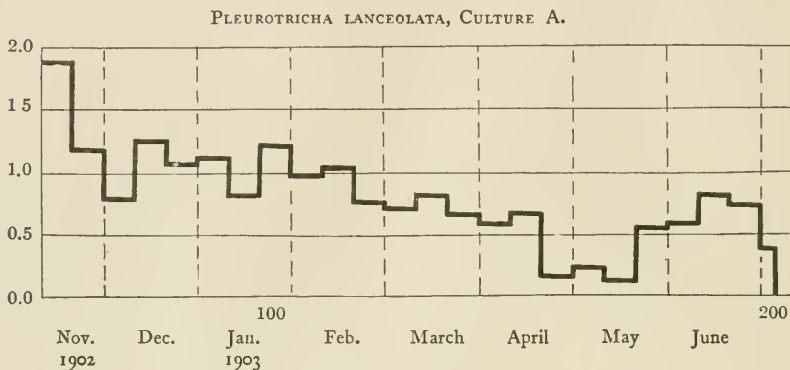

DIAGRAM III.

Complete history of *Pleurotricha lanceolata*, Culture A, from start (November 10, 1902) to finish (July 3, 1903). For method of plotting, see Diagram II.

#### 4. *Pleurotricha lanceolata*, Culture B.

A second culture of *Pleurotricha lanceolata* was begun November 25, 1902, with an individual found in some material in the Columbia laboratory which had been recently collected at Van Cortlandt Park, New York City. This culture was carried on by the method used in all previous cultures for 480 days, and reached during this time the 448th generation, when it was lost by an accident similar to that which terminated the *Oxytricha B*-culture. The culture-curve plotted in Diagram IV shows that throughout the life of the culture a general average rate of nearly one division per day was maintained.

#### 5. *Gastrostyla steinii*, Culture A.

A culture of *Gastrostyla steinii* was started on May 28, 1904, with a specimen which was captured in a hay-infusion in the Williams College laboratory. For convenience I have desig-

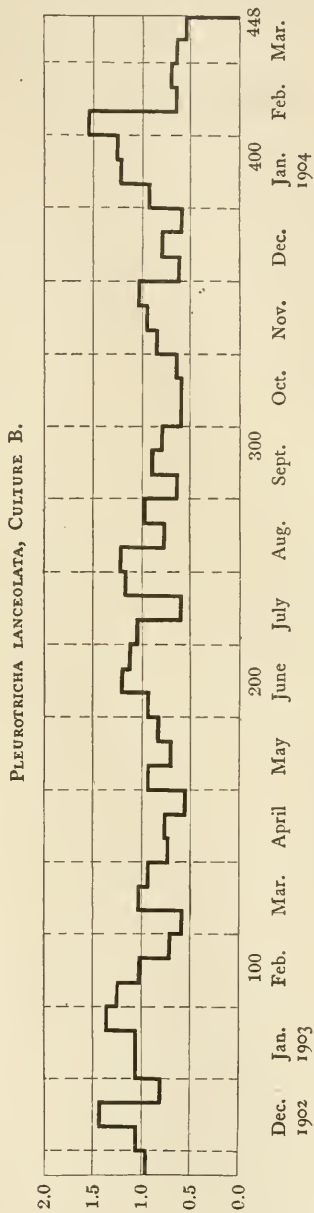

Complete history of *Pleurotricha lanceolata*, Culture B, from start (November 25, 1902) to finish (March 13, 1904). Method of plotting is the same as for Diagram II.

nated this Culture A, although but one culture of this species has been studied. The culture was put at once on a grass-infusion diet and continued on the same during its life.

From Diagram V it will be seen that the rate of division for the first three periods was very close to one division per day. On June 25, which fell just at the end of the third period, I moved the culture from Williamstown, Massachusetts, to New York City. The greatly increased division-rate, which appeared in the following period and was augmented in the period succeeding that to almost two and one-half divisions per day, is difficult to account for with any certainty. The jolting which the animals received

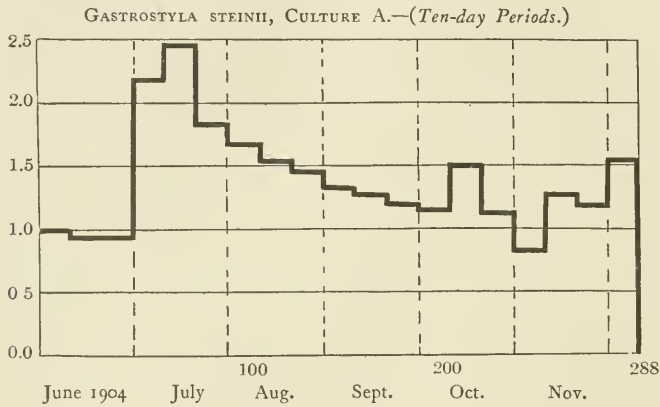

DIAGRAM V.

Complete history of *Gastrostyla steinii*, Culture A, from start (May 28, 1904) to its extinction (December 5, 1904) averaged for *ten*-day periods. Method of plotting the same as in previous diagrams.

on the trip to the city, the change to city tap-water, the change of grass with which the infusion was made, and the increased atmospheric pressure are prominent among the factors which may have tended to stimulate the fission-rate. Further, the treatment of the culture was exceedingly uniform beginning with its location in New York as I wished to see if the minor fluctuations in the division-rate, so prominent in the earlier cultures, could be modified or entirely eliminated by still more stable conditions. Again, I employed this culture as a "control" for certain experiments on the effects of salts on the division-rate and

GASTROSTYLA STEINITZ, CULTURE A.—(Five-day Periods.)

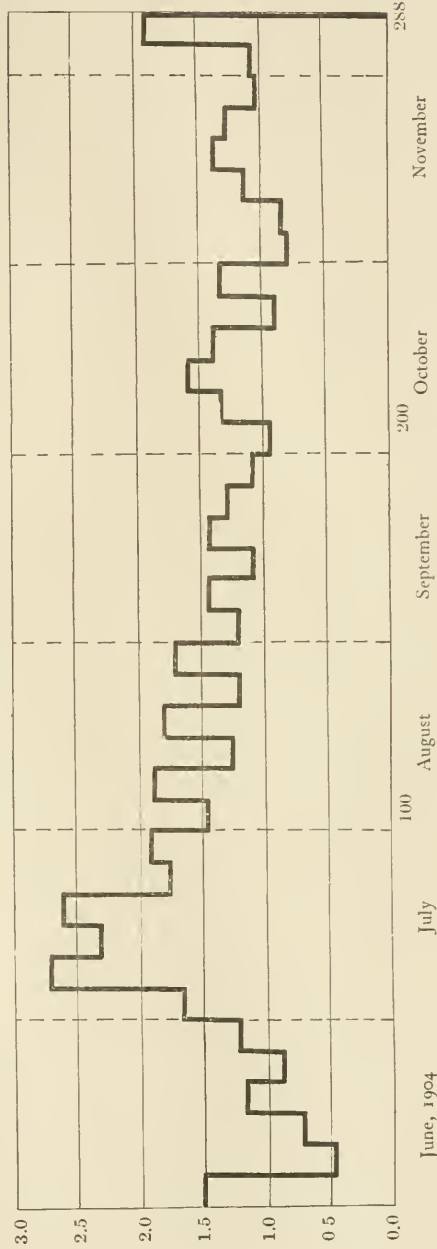

DIAGRAM VI.

Complete history of *Gastrostyla steinitz*, Culture A, averaged for five-day periods. Compare with Diagram V.

for this purpose exactness was most essential.<sup>1</sup> Whatever factor or factors caused the high division-rate of the fifth period, the effect was not lasting for in all of the succeeding periods up to, and including, the thirteenth, the rate steadily decreased and at a remarkably uniform rate. During the twelfth period (end of September) I moved the culture back to Williamstown. No effect is to be seen in the succeeding period but the rise in the fourteenth period undoubtedly is due to this change. This time the rise was by no means so marked and it was evident only after a latent period of ten days or more. This possibly can be explained by the fact that the "potential of vitality" of the infusorians was considerably less than when the first removal took place.<sup>2</sup> Like the acceleration at the first removal, this second one was not lasting as, during the following ten-day period, the fission-rate settled down to where we should expect to find it if the culture had been carried along without any disturbing influence. Beginning with the next period (No. 16) the very exact treatment which I had employed was discontinued and the change of liquid was made only every other day, and then not at exactly forty-eight hour intervals. The effect of this is at once apparent in the considerable fluctuations in the fission-rate shown in the culture-curve during the remaining four periods of the life of the culture. At the beginning of period 20, *i. e.*, at the 191st day of the life of the series, when the animals were dividing on the average three times in two days, the culture suddenly died out, stock and all, at the 288th generation. I noted that the infusorians were exceptionally active on the slides just previous to their extinction. This sudden death of the culture cannot be attributed to any accidental change in the liquid medium as the stock was affected similarly at the same time.<sup>3</sup>

---

<sup>1</sup>I endeavored to secure this uniformity of treatment and culture medium: (1) By changing the culture medium daily and at the same hour, thus making the daily records of just twenty-four-hour periods. (2) By using the same kind of grass and grass grown in the same place. (3) By washing the grass very thoroughly and boiling it for one minute. This was given as soon as it reached the room temperature.

<sup>2</sup>Calkins ('02, 1) found, however, that a journey which he made with his *Paramœcium* cultures when they were on a descending cycle accelerated the fission-rate, while a return journey made when the cultures were on the ascending cycle produced a retarding effect.

<sup>3</sup>It will be recalled that the death of Maupas's culture of *Stylonychia pustulata* was preceded by a period of more rapid division of almost three weeks' duration.



IV. DISCUSSION OF THE DATA OF THE CULTURES.

1. *Rhythmical and Cyclical Variation in the Rate of Division.*

One has but to glance at the plotted curves of the various cultures (Diagrams I to VI) to see that all the species of Infusoria studied pass through periods of greater and less dividing activity when subjected to a stable environment. These periods, upon analysis, are resolved into two kinds: First, the short, more or less rhythmical fluctuations in the fission-rate which I shall refer to as "rhythms"; and second, the long downward trend of the cultures (especially prominent in the *Oxytricha A*-culture) from their beginning to end, or, in the case of *Oxytricha A*, from its start to its recovery by stimulation at about the 250th generation, and again from this point through the second long downward sweep which ended with its extinction. This second type of change of fission-rate I regard as the "cycle." I am satisfied that these two kinds of variation are due to different causes. I believe the rhythms to be somewhat superficial in character and due *in part* to slight variations in the environment, the most important of which is change in temperature. This belief is based on the remarkable agreement which obtains between the rhythms and the fluctuations in temperature. In Diagram VII there is plotted a section of the culture-curves of all the four cultures which were carried on simultaneously, and above them the temperature curve. The agreement is seen to be more marked in the *Oxytricha* cultures; in the *Pleurotricha* series, the similarity, while not as striking, is too exact to be a mere coincidence, and serves to emphasize the fact that while temperature does influence the rate of multiplication, it is not the most important element among the factors which cause fluctuations in the rate. It is only natural that temperature variations should affect the division-rate, if not directly, at least indirectly through the effect on the multiplication of bacteria and therefore upon the food-supply, and this has been shown to be the case by Maupas and Calkins.

I believed there was another and more fundamental factor underlying the rhythms, and with this in mind I took still greater precautions to have the environment as nearly constant as possible in the more recent culture of *Gastrostyla steinii* (see note, p. 600). From the results of this series when plotted in periods of ten days (Diagram V), it would seem that my idea

was wrong and that with a constant medium all rhythms could be removed. To test it still further the same results were plotted for five-day periods. This brought the rhythms to view again (*cf.* Diagram VI) in such beautiful regularity that it seems to me to show beyond doubt that the rhythmical element of the division-rate cannot be caused entirely by temperature changes or by imperceptible fluctuations in the food supply, but that it is due, in the last analysis, to factors of a more complex character. Variation in the rhythm of division is well known in the development of the metazoön egg, and it has yet to be satisfactorily explained. Towle ('04) in a recent paper on the effects of stimuli on *Paramœcium* is led to make this interesting statement: "There may even prove to be rhythmical changes in sensitiveness like those described by Lyon ('02; '04) for cleaving eggs, and Scott ('03) for unfertilized eggs. Something of this nature is indicated by the fact that *Paramœcia* from the same culture vary in sensitiveness from day to day." In my work on the effects of chemicals on *Infusoria* I have found that individuals react differently at various times to a given stimulus (*cf.* p. 616 *et seq.*) and I believe we have the clue to these "changes in sensitiveness" manifested in the rhythms of the fission-rate.

A point of some interest in regard to the rhythms in the *Oxytricha* A-culture is the fact that the slowest fission-rate of each rhythm in the descending cycle is less than that of the slowest rate of the preceding rhythm. In the ascending cycle also, the slowest rate in each rhythm is greater than the slowest rate of the preceding rhythm.

So far we have not considered the long trend of the division-rate, which I regard as the cycle as I believe that this is directly comparable with the cycle of Calkins's *Paramœcium* cultures. The cycle obviously extends over more generations in *Oxytricha* than in *Paramœcium* though in both cases it is a variable number both in the same culture and in different cultures of the same species. Maupas's rather definite limits to the life-cycle are not substantiated by this work as will be readily seen by comparing the various culture-curves. It must be borne in mind, however, that neither Maupas's chief cultures nor my own were started with ex-conjugants, and therefore the number of generations does not afford a just basis of comparison, since they indicate merely the number of bipartitions since the culture began and in no sense

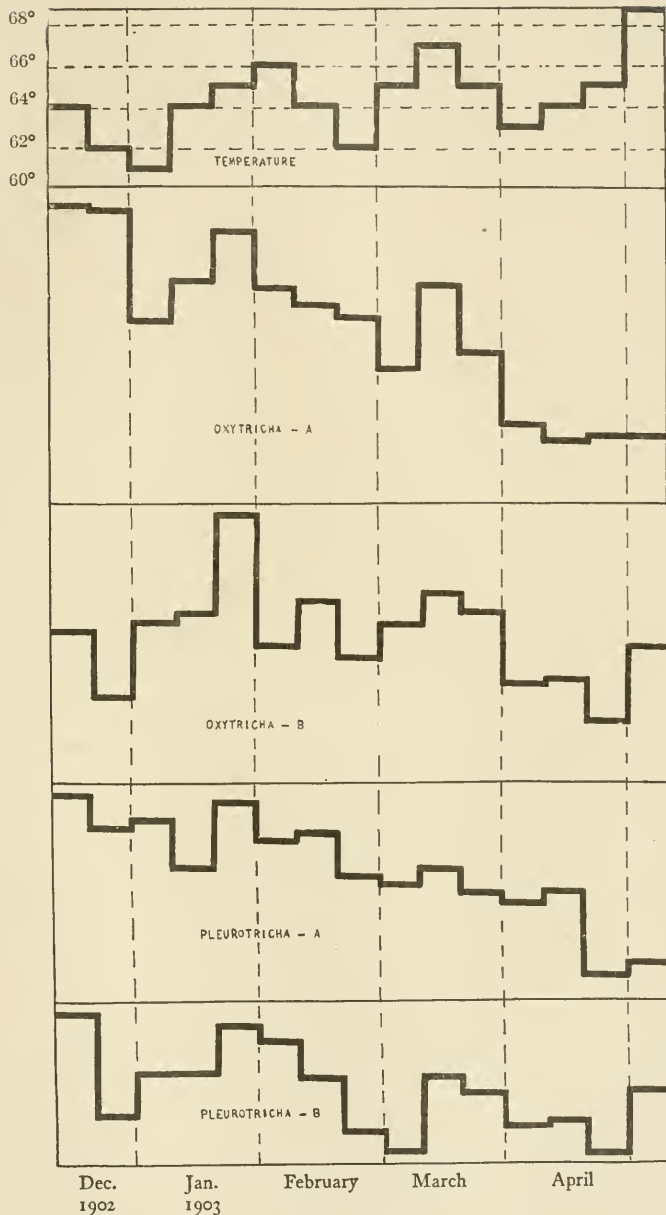

DIAGRAM VII.

Sections of the culture-curves of *Oxytricha* A, and B, and *Pleurotricha* A, and B, together with the temperature curve for the same period (December 10, 1902 to May 9, 1903), showing the correspondence of the "rhythms" of the division-rate with the fluctuations in temperature.

the "age" of the culture with reference to the last conjugation period. The number of generations from the recovery of my *Oxytricha A*-culture to its extinction gives the number of divisions in a cycle of an artificially stimulated line, but it remains to be shown that this is directly comparable to "rejuvenescence" by conjugation.

Joukowsky carried a series of *Pleurotricha lanceolata* through 458 generations and found no signs of degeneration, and he suggested that degeneration depends not on the number of divisions only, but on the rapidity with which they succeed each other. This conclusion, on *a priori* grounds, would seem reasonable, but my cultures give no evidence to substantiate it. Calkins, on the other hand, lays more emphasis on the duration in time of the cycles than on the number of generations passed through, and he showed ('04) that about six months is the period of the cycle in *Paramœcium*, but it would seem that about three months was the result reached by other workers on this species. Calkins ('02, 1, 2, 3) himself, in his earlier studies on *Paramœcium*, believed that the cycle in this species was approximately of three months' duration, as he interpreted the smaller trimonthly fluctuations as the cycles. I am satisfied that these periodic lesser changes in vitality which are so conspicuous in his culture-curves are identical with what I have termed rhythms in my cultures, and in the light of his results with *Paramœcium*, it is probable that the earlier workers on this species, Joukowsky and Simpson, have been dealing with rhythms rather than cycles. I believe that it is essential to recognize a sharp distinction between "rhythms" and "cycles," which may be defined as follows:

*A rhythm is a minor periodic rise and fall of the fission-rate, due to some unknown factor in cell-metabolism, from which recovery is autonomous.*

*A cycle is a periodic rise and fall of the fission-rate, extending over a varying number of rhythms, and ending in the extinction of the race unless it is "rejuvenated" by conjugation or changed environment.*

The question of the number of generations, as well as the time duration, of a life-cycle, is very uncertain and extremely difficult to determine as it is probably dependent upon more than one factor. My cultures lead me to believe, with Simpson, that the personal equation, if I may use that term, of the individual selected to start a culture has the most influence in determining the number

of generations attained before "the initial potential of vitality" is exhausted. Calkins's discovery of what he calls "incipient fertilization" in Paramœcium—that is, of two ex-conjugants which continue to live "one is invariably far more vigorous than the other"—would seem to bear out this point and to show that the number of generations or the period over which a cycle extends is not a point of great moment.

Taken as a whole my cultures show conclusively that the three species of hypotrichous ciliates studied are subject to periods of greater and less dividing activity, and since the fission-rate is probably a fair criterion of the metabolic activity of the protozoan cell, that ciliates pass through alternating periods of greater and less general vitality. This is also the general conclusion reached by Engelmann, Bütschli, Maupas, Joukowsky, Simpson, and Calkins, and from the range of species investigated it can probably be accepted as of quite general occurrence among the Infusoria.<sup>1</sup>

## 2. Artificial Rejuvenescence.

Calkins ('02, 1) showed conclusively that Paramœcium cultures when becoming extinct can be revived by the application of various

---

<sup>1</sup>Peters ('04) working on Stentor, states that "neither direct observation nor the experiments made, furnish evidence of any *inherent* periodicity of division. The present experiments show that, except when some special modification of the medium exists (*e. g.*, presence of potassium chlorid in excess), multiplication runs, in the main, parallel to metabolism." Peters's experiments were not planned directly to investigate this point and I fail to see, from his description of the methods employed, how cyclical variation in the fission-rate, unless very pronounced, would be apparent. That "multiplication runs, in the main, parallel to metabolism" is, I take it, not open to question, and is in no way opposed to periodic fluctuations of the fission-rate. Peters says further, in regard to the culture medium employed in determining periodicity of division, that "such promiscuous mixtures as hay infusion of *unknown composition* will not suffice. Since frequent chemical analyses are impracticable, it will be necessary to construct by trial artificial media of known composition." Undoubtedly hay infusion is not an ideal culture-liquid, but when the hay or grass is carefully selected and thoroughly washed and otherwise treated uniformly, and when this is prepared fresh each day and employed as soon as it has reached the room-temperature, there is little chance for fermentation, and I believe that about as near a perfect medium is obtained as is practicable. Undoubtedly the ideal culture-liquid would be one artificially combined so that its salt content, etc., is accurately known; but as Peters himself says, ". . . a food supply must be added to the salt solution, and this requirement has proved to be a difficulty. For the addition of any food that has been found available utterly changes the salt content both qualitatively and in its proportions." To supply this demand Peters added to the artificial medium which he concocted, "some dry leaves or dead reeds, or both. . . . The final step is to 'seed' this culture with a mixture of all sorts of Infusoria, and other living material from thriving cultures." This done, I do not see how a hay-infusion could be a more promiscuous mixture.

stimuli, and he found that an extract of beef, among others, was most effectual. As previously stated, I employed beef-extract as a stimulant during the first depression period of the *Oxytricha A*-culture which was at its height in May, 1902, and in July, 1902, after a latent period of about six weeks, one series suddenly sprang into new life. It is certain that something "rejuvenated" the culture at this time and I have every reason to believe that it was brought about by the salts of the beef-extract, and that we have here a case of stimulation analogous to "artificial parthenogenesis" as Calkins suggests in his *Paramœcium* work.

### 3. *Conjugation.*

My endeavor to study the effect of conjugation on the life-cycle of *Oxytricha fallax*, *Pleurotricha lanceolata*, and *Gastrostyla steinii* has been in vain, as at no time during the life of any of the five cultures have I succeeded in getting a single syzygy. Numerous individuals from the A and B cultures were placed together at different times in an endeavor to get exogamous conjugations, but to no purpose. The same is true of endogamous conjugations. With Maupas's conditions of conjugation in mind attention has been paid to the amount of food present but without result.

It seems rather remarkable that *Oxytricha* should pass through 860 generations, *Pleurotricha* through 448 generations, and *Gastrostyla* through 288 generations and at no time show any tendency to conjugate. The significance of this is rather difficult to see. Joukowsky, however, found no conjugations in his long culture of *Pleurotricha*, and Maupas secured none in his cultures of *Stylonychia mytilus* or *Oxytricha* sp. though his other series yielded plenty of syzygies. It is not uncommon to find hypotrichous forms conjugating in wild cultures in the laboratory, so that it is evident that some condition must prevail there which does not obtain in the experiments, and it is just possible that an excess of carbon dioxide and other noxious gases in these wild cultures may be the provoking cause; but it seems more probable, since the physical state of the protoplasm of the infusorian undoubtedly plays an important rôle in the conjugating process, that the required "miscible state" is prevented in artificial cultures through the scarcity of certain salts in the liquid medium used. In the

light of Maupas's results with *Oxytricha* sp. and *Stylonychia mytilis*, and of Joukowsky's with *Pleurotricha lanceolata*, and also my own on two cultures of *Oxytricha fallax*, two of *Pleurotricha lanceolata* and one of *Gastrostyla steinii*, it would seem to be questionable whether conjugation is of so frequent occurrence among the Hypotrichida as in some other groups of Ciliata.

V. PHYSIOLOGICAL AND MORPHOLOGICAL VARIATION DURING THE LIFE-CYCLE.

Maupas emphasized the fact that various changes, cytoplasmic and nuclear, take place in Protozoa as "senile degeneration" advances; and he also found physiological evidence in the form of lessened vitality, increase of endogamous conjugation, and infertile syzygies. Joukowsky found no morphological changes in *Paramœcium* but observed that the rate of division decreased as the cultures advanced and that many of the animals became sluggish. In an eight month culture of *Pleurotricha* he found no signs of degeneration. Simpson made some observations on three to four month cultures of *Stylonychia pustulata*, *Paramœcium caudatum*, and *Paramœcium putrinum*, and while he did not find degeneration in such specific form as nuclear changes or loss of external appendages, still he was "convinced of a gradual ebbing of vital energy as the series proceeds, which expresses itself in slower motion, in a tendency to inactivity and general listlessness, if the word be admissible in this connection, as also in a certain diminution of size that was not remedied by any amount of food." Calkins ('04), however, found marked cytoplasmic and nuclear changes in his long *Paramœcium* cultures, and physiological degeneration was manifested by irregular and abnormal divisions, decreased division-rate, tendency to endogamous conjugations, and above all by the "death of all members of a series fed continually on the same diet of hay-infusion."

1. *Physiological Variation.*

In my cultures, physiological changes have been manifested chiefly in the slowing down of the division-rate after a greater or less number of generations, and coincident with this, in a considerable lessening of the general activity of the infusorians.

The general behavior of individuals on the slide is quite different at various periods in the life-cycle, and by it the condition of the culture can be estimated with some degree of accuracy. Although the activity of the animals is considerably lessened during depression periods, I have not found that their power of taking food is diminished since the oral cilia vibrate normally and keep a continuous stream of food particles passing into the mouth opening, and this results in a black appearance of the infusorians due to accumulated and unassimilated food.

Another indication of physiological disturbances during periods of depression is the greater frequency of pathological divisions at this time, and Calkins found this to be the case in *Paramœcium* cultures. An interesting specimen which occurred in the A-culture of *Oxytricha*, when the vitality was extremely low in June, 1902, is shown in Fig. 21.

## 2. *Morphological Variation.*

For the purpose of determining the morphological changes which occur during the life-history, permanent preparations were made from time to time during the life of each of the cultures.<sup>1</sup> The series of preparations is particularly complete for the *Oxytricha* A-culture, from the time that series was approaching its first depression period through its recovery by stimulation, and then through the second cycle which resulted in death. On this account, the following description is based on this series of some two hundred slides, while the lesser series of *Oxytricha* B, *Pleurotricha* A, and B, and *Gastrostyla* A are used for confirmation and comparison.

The typical cytoplasmic structure of *Oxytricha fallax*, *Pleurotricha lanceolata*, and *Gastrostyla steinii*, is practically identical and is best described as alveolar throughout. As in all the hypotrichida, no distinction is visible between ectoplasm and endoplasm. The ectoplasmic modifications such as cilia, cirri, and membranelles, of course, vary in a characteristic manner for each species, but it is unnecessary to consider these here. In *Oxytricha* and *Pleurotricha*, as is well known, there are two ellipsoidal macronuclei situated more or less symmetrically in the cell, while

---

<sup>1</sup>For description of technique, see section on General Methods and Technique.



in *Gastrostyla* there are four macronuclei similarly placed. The macronuclei in all three species consist of at least two elements: First, a substance, undoubtedly chromatin, having a strong affinity for nuclear dyes; and second, a clear substance, resisting all stains, which may be termed achromatin. The general appearance of the nucleus is nearly homogenous though this is probably caused by the massing of a granular matrix. A membrane surrounds the nucleus and a very delicate commissure apparently connects the macronuclei though it is very difficult to determine. From time to time a *Kernspalt* is observable. Associated with each macronucleus is a small spherical micronucleus; in *Oxytricha* and *Pleurotricha* there are typically two, and in *Gastrostyla* four, micronuclei. The staining reaction of the resting micronucleus is the same as that of the macronucleus. A typical specimen of *Oxytricha fallax* is illustrated in Fig. 15.

During the earlier part of the *Oxytricha* A-culture no preparations were made, so that during the first period of decline up to the sixteenth ten-day period (Diagram I) I am unable to trace the morphological changes. On April 2, 1902, however, two individuals of the 230th generation were preserved. A glance at the photographs of these specimens (Figs. 1 and 2) shows that marked vacuolization of the cytoplasm has occurred in each case. In Fig. 1 the two macronuclei are considerably displaced in the cell, and each shows a peculiar vacuolized condition of the nuclear material, the chromatin being segregated about what appear like bubbles of the achromatic substance. Each macronucleus is surrounded by a clear area which separates it sharply from the cytoplasm. I believe that this clear area is caused by an accumulation of the achromatic substance against the nuclear membrane, which thus produces the appearance of a halo about the nuclear bodies. In this particular specimen there are two micronuclei present, one being nearly invisible in the photograph as it is somewhat below the plane of focus. Fig. 2 shows the same condition of cytoplasm and nuclear material but the two macronuclei are fused and the whole mass is surrounded by the halo. At least three micronuclei are present in the preparation, two of which are visible in the figure, so that we have a case of micronuclear reduplication similar to that which Maupas described in his culture of *Oxytricha* sp. Specimens from A-2 of the 239th generation (Fig. 3) and A-1 of the 241st generation (Fig. 4) show a

fused condition of the macronuclei similar to that in Fig. 2, though the chromatic material appears somewhat more homogenous. Here again the micronuclei, with two exceptions, are out of focus. Other characteristic specimens of this period of declining vitality are shown in Figures 5, 6, 7 and 8, all representing forms from the 243d to the 247th generation (*cf.* Explanation of Plates).

The specimen illustrated in Fig. 9 is of the 250th generation and is the last of the descending cycle of A-1, since on July 7, 1902, this line sprang into renewed dividing activity (*cf.* p. 592). The marked improvement of the cytoplasmic and nuclear condition of the infusorians is shown in an individual of the 256th generation (Fig. 12). Here the macronuclei, in outline and in general appearance, are again approaching the typical condition, and the position of the micronuclei in relation to the macronuclei is also more typical. Lines A-2, A-3, and A-4, however, which remained dividing at the slow rate, show no improvement in their nuclear condition, as is seen in specimens of the 255th generation (Figs. 10 and 11).

The cytoplasm of the "rejuvenated" individual, from line A-1, represented in Fig. 13 is still somewhat vacuolized, but the macronuclei and micronuclei are nearly typical. The specimen is quite small but this is due to the high rate of division prevailing at this period. This reduction in size is still more apparent in preparations of the 331st generation (Fig. 14), but beginning at about the 409th generation (Fig. 15) the size again increases with the slightly decreased fission-rate. This beautifully diagrammatic condition of the nuclear apparatus is the prevailing state in the large majority of specimens at this period of great reproductive activity. One most interesting exception, however, is that in two lines of the culture, specimens from the 361st to 369th generations lack the posterior micronuclear body. This is but temporary and for almost one-hundred generations after this the normal condition prevails. Preparations of the 458th generation again show evidence of a changed condition of the micronuclei since now they appear pale; the chromatin having but little affinity for the stain. This peculiarity reaches a climax at the 473d generation when the micronuclei appear almost perfectly clear; but from this time on they again resume their normal staining capacity.

Starting at about the 542d generation the cytoplasm shows signs

of vacuolization, and this increases steadily and at approximately the 600th generation the nuclear apparatus begins to differ from the normal. An early stage is shown in Fig. 16, and a later stage exhibiting nuclear fragmentation in Fig. 17. The last stage in this cytoplasmic and nuclear degeneration is shown by specimens of the 853d and 854th generations (Figs. 18, 19 and 20) in which the cytoplasm is greatly vacuolated, the ventral cirri reduced, the macronuclei distorted and fragmented, and the micronuclei increased beyond the typical number; a condition closely similar to that which obtained at the 230th generation (Figs. 1 and 2). The series died out at the 860th generation (*cf.* p. 594).

An interesting feature is the marked variation in size of the infusorians at different periods of the life-cycle. Previous workers have found that a gradual decrease in size occurred as "old age" ensued. This certainly does not hold for the species in question. Fig. 15 shows about the typical relative size of a normal specimen, and a comparison of this with the figures of the succeeding generations and with Figs. 1 through 8 shows that *the size gradually increased as the rate of division decreased*. This, however, is true only up to a certain point for, during the last two days before death, the size decreased quite rapidly, a decrease due to a shrinking of the cytoplasm which produced a more or less abnormal contour of the individuals. This condition is shown somewhat inadequately in the specimen illustrated in Fig. 9, which is the last of the line before the culture was "rejuvenated" in July, 1902. After this recuperation, however, the size of the infusorians decreased remarkably (from the normal) with the high rate of division (*cf.* Figs. 13 and 14).

The B-culture of *Oxytricha* (*cf.* Diagram II), which was lost by accident at the 429th generation, shows far less fluctuation in vitality than does culture A, indicating that the potential of vitality of the B-series was considerably greater. Cytological study of the preparations made from time to time shows that, beginning at about the 140th generation and extending over approximately the ensuing seventy-five generations, the anterior micronucleus was not present. This was the only morphological change apparent during the life of this culture. A typical specimen in the 365th generation is shown in Fig. 22.

In the two series of *Pleurotricha* I have found no nuclear variation at any time. Although neither of these cultures was actually carried to natural death, still from the large number of generations attained it would seem that nuclear changes should have appeared if they occur in this species. Joukowsky's culture of 458 generations of this species, however, gave the same result and that this has been held unjustly as opposed to Maupas's conclusions is evident from my cultures. A slight cytoplasmic vacuolization appeared in both of my cultures as the series advanced. A specimen, in a late division-stage, from the 413th generation of culture B is shown in Fig. 23.

The *Gastrostyla* culture showed morphological changes in the form of vacuolized cytoplasm and distortion of the macronuclei during the later generations; but at the time of the sudden death of this series "degeneration" was by no means so marked as in the *Oxytricha* A-culture long before death ensued.

Briefly reviewing the chief morphological changes apparent during the various cultures, we have: *Oxytricha* A, cytoplasmic vacuolization, disappearance of one of the micronuclei for a period, and later an increase in their number beyond the norm, distortion and fragmentation of the macronuclei, degeneration of part of the ciliary apparatus, and, finally, a gradual increase in the size of the infusorians as degeneration advances; *Oxytricha* B, one of the micronuclei was not present during a number of generations; *Pleurotricha* A and B, slightly vacuolized cytoplasm; and *Gastrostyla* A, cytoplasmic vacuolization and distortion of the macronuclei.

Wallengren ('01) made a careful study of the morphological changes which occur in starved *Paramœcia*, and discovered that in the later stages the endoplasm is distorted by huge vacuoles and finally the macronucleus is deformed and broken. The micronucleus, however, remains unscathed throughout the starvation changes. Calkins confirmed these starvation observations and also found that quite similar morphological changes occur in degenerating *Paramœcia* cultures, and he believes that the similarity of the changes in the two cases indicates that it is the digestive function which becomes impaired in the declining series, since when in this condition the organisms still take food but apparently are unable to utilize it. In my own cultures it has been clear that the power of taking food is not diminished appreciably

during depression periods and the very similar morphological changes which occur in the hypotrichs studied, justifies, I believe, the assumption that the power of assimilation becomes diminished as the culture proceeds and that the effect of the beef-extract is essentially that of concentrated nutrition, resulting in the rapid assimilation of the salts, etc., necessary for the continued life of the animal.

It has been customary to regard the macronucleus as relatively vegetative in function and the micronucleus as reproductive; and this accords well with the results of these experiments, in so far as the morphological variation of the macronucleus may be regarded as an indication of the apparent lack of assimilation of the food taken. Throughout the culture no form-changes were apparent in the micronuclei themselves, but they showed a tendency to numerical reduction when the fission-rate was at the highest, and to reduplication when the lowest rate of multiplication ensued. This may be explained by supposing that the exceedingly rapid rate of assimilation, calling for such frequent bipartitions, results in the exhaustion of the micronuclei during these periods; but when assimilation is at a low ebb, the little demand for the dynamic forces of the cell results in the reduplication of the micronuclei beyond the typical number. Thus Maupas's observations that in certain hypotrichous forms the micronuclei are reduced in number, and later appear again in greater number, is entirely substantiated by these cultures. Variations in the number of micronuclei is not unknown in other forms. Johnson ('93), for instance, working on *Stentor*, found that from one to eight may be associated with each node of the macronucleus. However, the disappearance of all the micronuclei in certain forms, as described by Maupas, has never occurred in my cultures, and the continuance of his series for many generations without this cell-organ I believe is open to question.

Whatever may be the correct interpretation of the nuclear changes taking place in the life-history of the hypotrichida, these cultures strongly suggest that it is customary to regard the structure most frequently observed in "wild" Infusoria as too fixed in character, and to overlook the fact that under varying conditions, modifications may occur which are in no way abnormal. Bütschli ('83) comments on the frequent presence of a coarsely alveolar or vacuolar structure of the protoplasm of certain ciliates

and believes that this should be sharply distinguished from the fine honey-comb structure which obtains in other forms, such as many of the hypotrichida; and he regards the observations of Sterki ('78), that *Stylonychia mytilus* has a markedly vacuolized structure, as an indication of abnormality. Simpson ('01, 2) made sections of what he regards as "absolutely normal" *Stylonychia*, and he states that they "showed the vacuolization fairly well developed. . . ." Again, the question of the fixity of form and position of the macronucleus has been variously discussed since Balbiani more than forty years ago observed a shifting in *Paramœcium*, to its recent consideration by Simpson through observations on various species. My own cultures give conclusive proof that the cytoplasm becomes considerably more vacuolated at certain periods in the life-cycle; but further, daily observation has shown that hardly any two individuals are identical in their cytoplasmic condition, and the same can be said of the position of the macronuclei and the accompanying micronuclei.

The fact that subjection to beef-extract gradually revived the cellular activity and caused the resumption of the normal condition of cytoplasm and nuclei, shows that up to the verge of extinction the cell-life can be revived. I think this indicates that we are hardly justified in assuming that Protozoa, when dividing at a low rate, with nuclei fragmented, etc., are exactly "abnormal." The fact that it is possible to restore such remarkable types as I have figured to the text-book "normal" condition suggests that we are justified in regarding these changes as phases in the life-history of the Infusoria which occur under certain conditions after a considerable period of vegetative reproduction.

#### VI. EFFECT OF INITIAL AND DAILY STIMULATION WITH SALTS ON THE RATE OF DIVISION.

The first essential for experimental work with salts on the fission-rate of Protozoa is to have a constant subject on which the stimuli are to be applied so that the results obtained shall be directly comparable. This condition is admirably fulfilled by cultures of Infusoria fed daily on the same diet and carried on in this way for many weeks; and such cultures probably afford as near a perfect "control" as it is possible to get for work of this kind.

The results obtained with beef-extract as a stimulant for worn-out Protozoa led me to test the effect of some of the more common salts on the fission-rate, since, as Liebig claimed, the stimulating property of beef-tea is probably due to the extractives and not to the small amount of proteid which it contains. For this work potassium phosphate (monobasic and dibasic), potassium chlorid, potassium bromid, and potassium sulphate; sodium chlorid, and magnesium sulphate were chosen. The series of experiments with these seven salts extended from the early part of July to the middle of September, 1904. The work with each salt extended over twenty days. The salts were made up into equivalent normal solutions<sup>1</sup> and these were then diluted as indicated in the descriptions of the individual experiments. In each case two solutions of different strength were employed, and each of these was applied both as an initial and as a daily stimulus. The culture of *Gastrostyla steinii* was used in this work (*cf.* Diagrams V and VI).

*I. Experiments with Potassium Phosphate (Monobasic and Dibasic).*

On July 6, 1904, eight cultures (each consisting of four lines) of *Gastrostyla* were started with individuals isolated from my culture A of this species, which had been under observation since May 28. Four of these cultures were used for experiments with the monobasic and four with the dibasic salt. Of these cultures, half were used for initial stimulation and half for daily stimulation; and of each half, one was used for  $\frac{n}{100}$  solutions and the other for  $\frac{n}{1250}$  solutions of the salt in question.

The method of applying the salt was, briefly, as follows: In the case of initial stimulation, one individual was placed on a slide with as little of the culture-medium as possible. To this was added the solution of the salt to be tested and this was removed again immediately and fresh salt solution put on. Each transference was performed with a pipet used only for this purpose. The length of each initial stimulus was thirty minutes and when this had expired the specimen was transferred back to the grass-infusion. In the case of daily stimulation the method of procedure

---

<sup>1</sup>The solutions were made according to the definition of "normal" solutions as given in Sutton's Volumetric Analysis, Eighth edition, 1900.

was identical except that the duration of the stimulation was ten minutes instead of thirty minutes.

The immediate effect of immersion in the monobasic salt was to cause the infusorian to rotate rapidly on its short axis for a couple of minutes, after which it began to move slowly about the slide, and by the end of the thirty minutes normal locomotion was entirely resumed. Practically the same behavior was caused by the application of the dibasic salt. I found, however, that this typical reaction varied somewhat with different individuals at various times; sometimes, for instance, the duration of the whirling motion was very much shorter and sometimes it was entirely absent. This is true not only for stimulation with potassium phosphates but also for stimulation with the various other salts tried. Slightly different reactions occurred with some of these other salts, but I have noticed the same variability. I am inclined to believe that the explanation of this variability in the reaction to a given stimulus at different times is in some way correlated with the slight changes in vitality which I have described as rhythms. I found also that when the salts were applied daily they soon ceased to cause any abnormal movements, even when their effect on the vitality of the animals, as determined by the division-rate, was detrimental. Here again there were occasional exceptions which point to periodical fluctuations in sensitiveness. This holds true for all the salts employed.

A glance at the diagram shows that the culture stimulated initially with  $K_2HPO_4$  in  $\frac{n}{1250}$  solution divided more rapidly than the control during three out of the four five-day periods of the experiment, and produced a greater effect than any of the three other experiments involving initial stimulation. Culture  $K_2HPO_4 \frac{n}{100}$ , initial stimulation, showed the next greatest effect, but this was manifested in a slowing of the rate in three out of four periods. In initial doses, then, the dibasic salt proved to be more effective—the greater dilution producing an accelerating effect and the lesser dilution producing a retarding effect. An examination of the data of the experiments on daily stimulation shows that  $K_2HPO_4 \frac{n}{1250}$  again produced the greatest change in rate, though this time it had a retarding influence.<sup>1</sup> Summarizing the results of the

<sup>1</sup>The curve for daily stimulation is not plotted for  $KH_2PO_4 \frac{n}{100}$  and  $\frac{n}{1250}$ , during three periods because the individuals stimulated were lost accidentally at these times.



twenty-day experiments with the two potassium salts, it is apparent that the dibasic salt had in every case a greater "net effect" than the monobasic salt; and that the more dilute solution of the dibasic salt produced a greater acceleration than the less dilute solution when used as an initial stimulus, and also produced a greater depressing effect when given daily. This is a clear-cut example

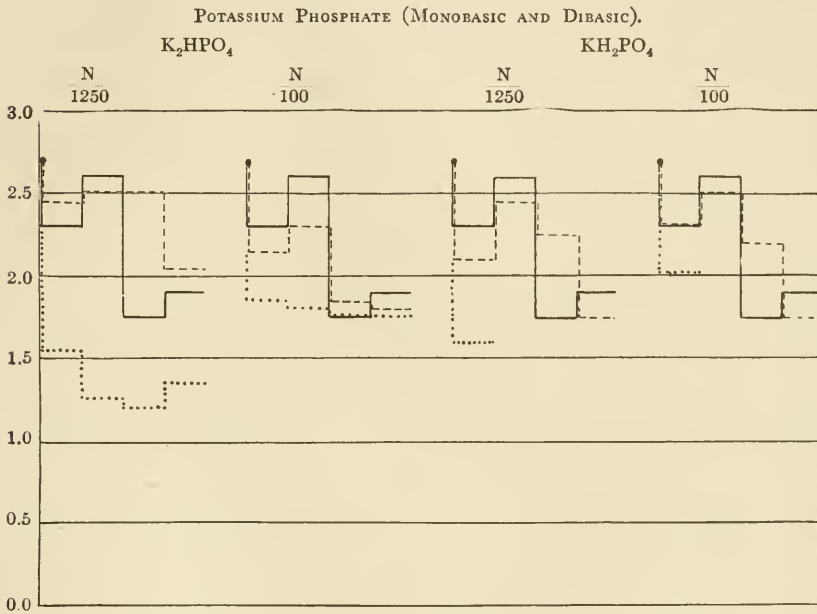

Effect of initial and daily stimulation with  $K_2HPO_4$  ( $\frac{n}{100}$  and  $\frac{n}{1250}$ ) and  $KH_2PO_4$  ( $\frac{n}{100}$  and  $\frac{n}{1250}$ ) on the division-rate of *Gastrostyla*. Averages are for five-day periods. Control (*Gastrostyla* A, on regular medium) is indicated by a continuous line; initial stimulation, by a broken line; and daily stimulation, by a dotted line. The eight experiments plotted in this diagram were carried on simultaneously from July 6 to July 26, 1904. (Cf. text.)

of a chemical being beneficial in a single small dose but detrimental when used frequently.

In view of the interesting results with the dibasic salt the  $K_2HPO_4$   $\frac{n}{1250}$  initial-stimulus culture was continued for some two months after the twenty-day experiment was over. The result of this work is plotted in Diagram IX. From the curve it will be seen that in the sixth period of the experiment the rate fell

below that of the control, and at this point the infusorians were again stimulated, as previously, for thirty minutes. This apparently accelerated the rate (as compared with the control), but only temporarily as in the eighth period it was again below the control. Another stimulation at this time again raised the rate, but as in the previous case the effect was not lasting. After

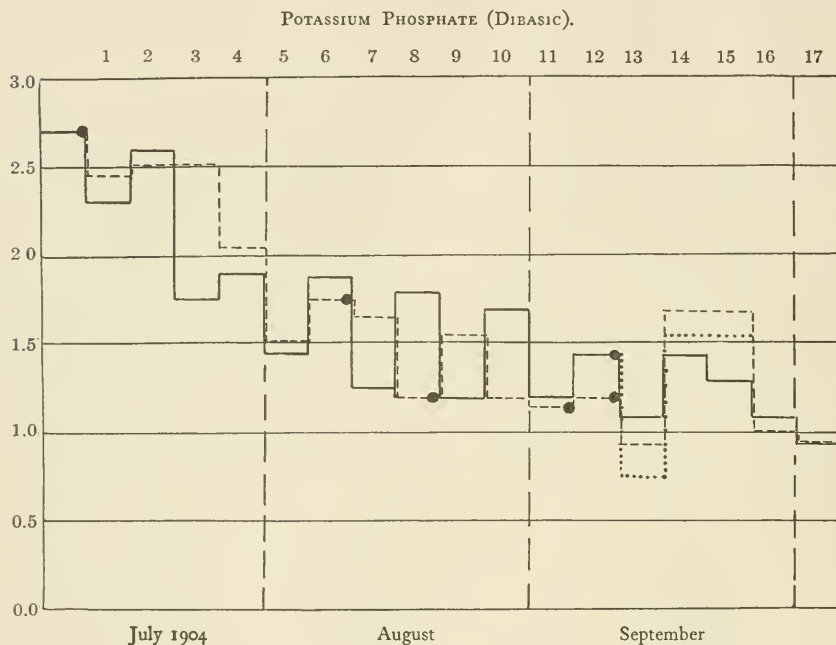

DIAGRAM IX.

This diagram shows the continuation of the experiment with  $K_2HPO_4$   $\frac{n}{T250}$  (cf. Diagram VIII) illustrating the effect of stimulation with this salt at different periods in the life-cycle. Method of plotting, as in Diagram VIII. Control = continuous line; regular  $K_2HPO_4$  series = broken line; new series stimulated = dotted line; time of stimulation = •. The figures above the diagram indicate the five-day periods. (See text.)

two more periods had passed, in each of which the stimulated line was dividing at a rate below the control, they were treated still another time with the salt-solution; but this time no acceleration was produced, but instead the rate, as compared with the control (cf. Diagram IX), fell still lower. The behavior of the culture here suggested the possibility that the lack of effect of the salt

was due to the series becoming accustomed to it, and accordingly I started a new series from the control and stimulated both this and the old series at the same time. From the results (see Diagram IX) it was evident that this hypothesis was not substantiated, for the new series showed even a greater drop in the fission-rate than did the old. Instead, it was apparent that the difference in effect of the salt at these later periods must be sought in the change in the general vitality of the culture itself. When the salt was first used the vitality of the series was considerably

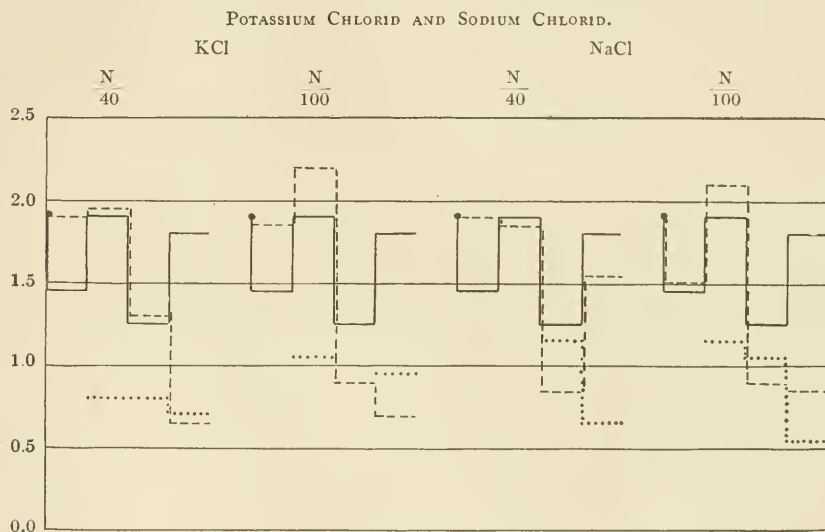

DIAGRAM X.

Effect of initial and daily stimulation with KCl,  $\frac{n}{40}$  and  $\frac{n}{100}$ , and NaCl,  $\frac{n}{40}$  and  $\frac{n}{100}$ , on the division-rate of *Gastrostyla*. Averages are for five-day periods. The eight experiments plotted in this diagram were carried on simultaneously from July 26, to August 15, 1904. Method of plotting is the same as in Diagram VIII.

greater than toward the end of the experiment, as is indicated by the comparative fission-rates of the two times; and the conclusion seems to be justified that a given stimulus produces different effects at different periods in the life-cycle. This result shows how complicated is the whole problem of the effect of stimuli on protoplasm, and the great amount of work that will have to be done before it will be possible to attain any satisfactory knowledge of the part played by a particular salt in the economy of the protozoön.

2. *Experiments with Potassium Chlorid and Sodium Chlorid.*

The experiments with KCl and NaCl were conducted precisely the same as those with the phosphates of potassium, except that an  $\frac{n}{40}$  solution was used in place of the  $\frac{n}{1250}$  of the phosphates. The accompanying curve (Diagram X) gives the results of the experiments.

The striking point about the effect of initial stimulation with KCl and NaCl in each dilution used is that they all accelerated the fission-rate during the first part of the experiment, and had a still greater opposite effect during the latter part, so that the "net

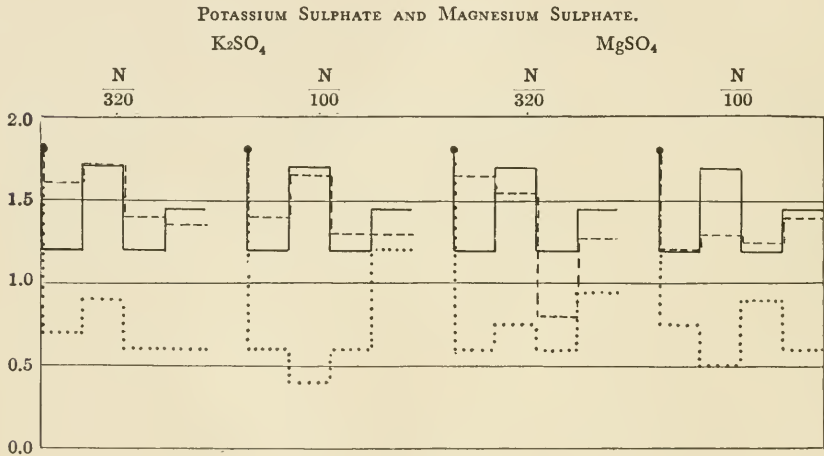

DIAGRAM XI.

Effect of initial and daily stimulation with K<sub>2</sub>SO<sub>4</sub>,  $\frac{n}{100}$  and  $\frac{n}{320}$ , and MgSO<sub>4</sub>,  $\frac{n}{100}$  and  $\frac{n}{320}$ , on the division-rate of *Gastrostyla*. Averages are for five-day periods. The eight experiments plotted in this diagram were carried on simultaneously from August 15, to September 4, 1904. Method of plotting is the same as in Diagram VIII.

effect" for the twenty-day experiment was a marked falling off in the number of divisions. A closer analysis of the results shows that KCl produced a greater variation from the control than did NaCl both when used as an initial and as a daily stimulus. In every case also the greater dilution produced the greater variation. Daily subsection to each of the salts proved to be uniformly

detrimental,<sup>1</sup> as was seen to be the case in the work with the two potassium phosphates. As far as these experiments go they would seem to indicate that potassium has more effect than sodium on the metabolic activity of *Gastrostyla*.

3. *Experiments with Potassium Sulphate and Magnesium Sulphate.*

The third series of experiments was with  $\frac{n}{100}$  and  $\frac{n}{320}$  solutions of  $K_2SO_4$  and  $MgSO_4$ . The results of the eight cultures together

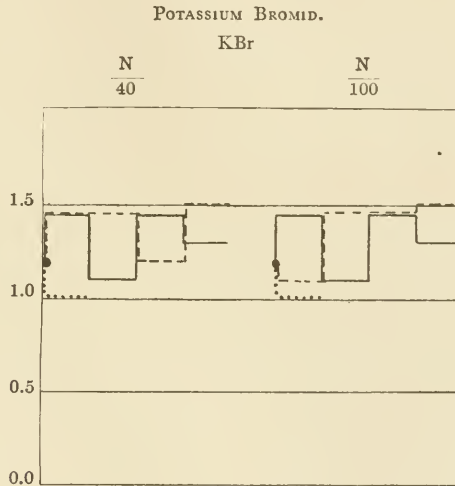

DIAGRAM XII.

Effect of initial and daily stimulation with KBr,  $\frac{n}{40}$  and  $\frac{n}{100}$ , on the division-rate of *Gastrostyla*. Averages are for five-day periods. The four experiments plotted in this diagram were carried on simultaneously from August 30, to September 19, 1904. Method of plotting is the same as in Diagram VIII.

with the control are shown in Diagram XI, and they indicate that an initial application of  $K_2SO_4$  in both dilutions used produced a slight acceleration in the division-rate, whereas  $MgSO_4$  under the same conditions produced a retardation. It is evident here again that the daily use of the salts was invariably detrimental; and also

<sup>1</sup>The omission of the curve at certain points is due to accidental loss of the specimens under experimentation.

that the greater dilution produced the largest variation in the fission-rate, except in the  $\text{MgSO}_4$  daily stimulus experiment.

#### 4. *Experiments with Potassium Bromid.*

The results obtained with potassium bromid in  $\frac{n}{40}$  and  $\frac{n}{100}$  solutions, are plotted in Diagram XII. This shows that KBr in both dilutions had on the whole a very slight accelerating effect on the division-rate, and also that the greatest variation from the control was caused by the  $\frac{n}{100}$  solution. The chief effect of KBr, however, seems to have been to change the rhythm of division as shown when plotted in periods of five days. The daily application of this salt also was deleterious, and I had especial difficulty in maintaining the culture for more than two days when subjected to daily stimulations, which accounts for the omission of the daily curve in three out of the four periods of the experiment.

#### 5. *Comparison of Results.*

Comparing the results of all the experiments with the seven salts when used as initial stimuli, it is clear that  $\text{K}_2\text{HPO}_4 \frac{n}{1250}$  caused the greatest acceleration of the division-rate, while  $\text{NaCl} \frac{n}{100}$  produced the greatest slowing of the rate. The largest variation from the control, when plotted in five-day periods, was shown by  $\text{KCl} \frac{n}{100}$ . All the salts tested agreed in having a marked deleterious effect when employed daily:  $\text{K}_2\text{HPO}_4 \frac{n}{1250}$  being slightly the most active in this regard. The table on the opposite page gives the actual status of each experiment in relation to the control for each five-day period of the work.

Calkins tried stimulating his Paramœcium cultures with various salts, among them the dibasic potassium phosphate and found that it not only produced an acceleration of the division-rate, but also that there were less fluctuations in the rate. His results show far more uniformity with this salt than do my own. Greeley ('04) investigated the effects of a number of salts on the physical structure of protoplasm and incidentally on the division-rate of Paramœcium, and he arrived at the general conclusion that "with Paramœcia from alkaline cultures, anions or liquefying agents stimulate cell-division, cations or coagulating agents inhibit it. Thus I have frequently observed in my experiments that when the liquefying solution is too weak seriously to modify the structure

TABULATED RESULTS OF SALT EXPERIMENTS.

SALT USED.	SOLUTION.	FIVE-DAY PERIODS.				TOTAL VARIATION IN FOUR LINES.	NET EFFECT IN FOUR LINES.	AVERAGE VARIATION.	AVERAGE NET EFFECT.
		1st	2d	3d	4th				
KH <sub>2</sub> PO <sub>4</sub>	$\frac{N}{100}$	0	-2	+9	-3	14	+4	3½	+1
	$\frac{N}{1250}$	-4	-3	+10	-3	20	0	5	0
K <sub>2</sub> HPO <sub>4</sub>	$\frac{N}{100}$	-3	-6	+2	-2	13	-9	3½	-2½
	$\frac{N}{1250}$	+3	-2	+15	+3	23	+19	5¾	+4¾
KCl	$\frac{N}{100}$	+8	+6	-7	-22	43	-15	10¾	-3¾
	$\frac{N}{40}$	+9	+1	+1	-23	34	-12	8½	-3
NaCl	$\frac{N}{100}$	+1	+4	-7	-19	31	-21	7¾	-5¾
	$\frac{N}{40}$	+9	-1	-8	-5	23	-5	5¾	-1½
K <sub>2</sub> SO <sub>4</sub>	$\frac{N}{100}$	+4	-1	+2	-3	10	+2	2½	+½
	$\frac{N}{320}$	+8	0	+4	-2	14	+10	3½	+2½
MgSO <sub>4</sub>	$\frac{N}{100}$	0	-8	+1	-1	10	-8	2½	-2
	$\frac{N}{320}$	+9	-3	-8	-6	26	-8	6½	-2
KBr	$\frac{N}{100}$	-7	+7	0	+4	18	+4	4½	+1
	$\frac{N}{40}$	0	+7	-5	+4	16	+6	4	+1½

Record of the variation in the number of divisions of each initial stimulus experiment from the control, during each five-day period; and also the net effect for the whole twenty days of the experiment. For example: the KH<sub>2</sub>PO<sub>4</sub>  $\frac{n}{100}$  culture, during the first five-day period, divided exactly the same number of times as the control; during the second period, two times less; during the third, nine times more; and during the fourth, three times less than the control. For the four periods of the experiment, then, there was a total variation of fourteen divisions, or a "net effect" of four more divisions than the control

of the protoplasm it will however, greatly increase the motility of the protoplasm and the rate of cell-division." Among the electrolytes employed by Greeley are three of the salts which I have used: KCl and  $\text{MgSO}_4$  with predominant cations and NaCl with the anion predominant. He found that  $\text{KCl} \frac{n}{40}$  and  $\text{MgSO}_4 \frac{n}{320}$  each exerted an inhibiting influence on the fission-rate, through a coagulating of the protoplasm. Referring to these salts he remarks that "the less active solutions, such as KCl and  $\text{MgSO}_4$  do not produce quite so dense a coagulum as the others, and the reaction is considerably slower." As already stated, my work with an initial stimulation of thirty minutes with  $\text{KCl} \frac{n}{40}$  and  $\text{MgSO}_4 \frac{n}{320}$  produced a quickening of the rate of fission for the first five days or more; the total result, however, for the twenty days of the experiment showed an inhibiting influence. With  $\text{NaCl} \frac{n}{40}$  Greeley found an increase in the rate and this agrees with the first period of my NaCl experiment, but here again I found a slowing of the rate for the total twenty days. It is impossible, though, to make a direct comparison of Greeley's results with my own, both on account of the great difference in the methods employed and because he gives no details of the individual experiments. Peters ('04) describes some experiments with KCl on *Stentor* in which he found that initial stimulation for ten minutes produced an increased division-rate for the three days over which the longer experiments extended. This accords with my results for the early periods of stimulation with the  $\frac{n}{40}$  and with the  $\frac{n}{100}$  solutions of this salt.

To draw any general conclusions from my experiments with salts on the division-rate of *Gastrostyla*, I think, would be hazardous. Before this can be safely done it will be necessary to perform many experiments on different forms. Work on this subject up to the present time, while affording a nucleus of data as a basis for future investigation, is too meagre and the methods employed by different workers too varied to make the results at all comparable. As Towle ('04) aptly remarks: "the first step toward a clearing of the haze that envelops the subject will be found, I believe, when an effort is made to unify the conditions under which different investigators are working." From this work on the Protozoa, I am persuaded that the most adequate method of attacking the problem is by breeding long cultures of Infusoria on a fixed diet. While this is a tedious process, it is the only way



in which it is possible to know with any degree of certainty exactly what the pedigree of the subjects of the experimentation is, and unless one has the daily record of the ancestry of each protozoön and knows its status in the life-cycle, any results obtained lose a large part of their value. Nothing emphasizes this point more forcibly than the record of my experiments with the dibasic potassium phosphate.

#### VII. EFFECT OF LIGHT ON THE RATE OF DIVISION.

Maupas ('88) made some interesting experiments on the effect of light on the division-rate of various Infusoria, by keeping cultures for one month in the light and then for one month in the dark and then comparing the rate of division during the two periods. But it would seem that his method is open to criticism for it is clearly impossible to keep the conditions absolutely constant during the two months of the experiments, not to mention the fact that, according to Maupas himself, "senescence" is increasing. Consequently it is impossible to say that the difference, or absence of difference, in the rate during two consecutive months shows the effect, or non-effect, of light on bipartition. I would call attention to the fact that he found less difference in light and darkness than my records show for any two consecutive months of any of the cultures when light and all other factors have been apparently constant.

With this in mind I made an experiment on the effect of light on the division-rate of *Oxytricha fallax*, and endeavored to eliminate the factors which seem to vitiate Maupas's experiments. This was accomplished by isolating an individual from each line of *Oxytricha* A-culture, and starting with them a second culture (designated A<sup>1</sup>) in absolute darkness.<sup>1</sup> By this method the light and dark series were carried on simultaneously and this ruled out the question of relative "senescence"; and at the same time variation in the food was reduced to a minimum, since the same infusion was supplied to both cultures simultaneously. Temperature differences were avoided also. It would seem, therefore, that light was the only factor removed in the case of culture A<sup>1</sup>, and

---

<sup>1</sup>The culture was necessarily, of course, subjected to light for two or three minutes each day when the record of divisions was being taken.

that this had a very insignificant influence on the fission-rate is shown by the accompanying table. The experiment certainly substantiates Maupas's result, however obtained, that light is of little or no direct importance in the economy of the ciliate.

Oxytricha A (light) .....	A-1 .....23 divisions. A-2 .....28 " A-3 .....17 " A-4 .....20 " —
	Total, 88 divisions.
Oxytricha A <sup>1</sup> (darkness) .....	A <sup>1</sup> -1 .....22 divisions. A <sup>1</sup> -2 .....26 " A <sup>1</sup> -3 .....16 " A <sup>1</sup> -4 .....18 " —
	Total, 82 divisions.
	—
	Excess in light, 6 divisions.

#### VIII. SUMMARY.

1. The chief object of the work was to ascertain if the life-history of hypotrichous Infusoria is characterized by "cycles," and if so, the cytological changes which occur and the effect produced on the cycles by changes in environment.

2. Two cultures of *Oxytricha fallax*, two of *Pleurotricha lanceolata*, and one of *Gastrostyla steinii* have been carried on. *Oxytricha* culture A extended from October 26, 1901, to July 14, 1903, during which time 860 generations were attained. Culture B was started December 10, 1902, and died out through an accident November 22, 1903. *Pleurotricha* culture A was isolated November 10, 1902, and became extinct July 3, 1903. Culture B was carried continuously from November 25, 1902, to March 13, 1904, when it was lost by an accident. The culture of *Gastrostyla* was started May 28, 1904, and died out December 5, 1904. The life-history of each culture is represented graphically by a curve which is plotted by averaging the number of divisions per day of the four lines constituting each culture, and then averaging this for five- or ten-day periods.

3. All the cultures give incontestable proof that the species studied pass through periods of greater and less general vitality

as measured by the rate of division. This cyclical change is most prominent in the *Oxytricha A*-culture. The periods of depression lead to death if the culture is subjected continuously to the same environment.

4. Minor fluctuations occur in the division-rate which I have termed "rhythms" and which are to be clearly distinguished from cycles. The rhythms are probably indicative of a rhythmical change in the metabolism of the organism, though they are influenced somewhat by almost imperceptible changes in the environment.

5. The results of the experiments seem to indicate that "rhythms" and "cycles" should be defined as follows:

A rhythm is a minor periodic rise and fall of the fission-rate, due to some unknown factor in cell-metabolism, from which recovery is autonomous.

A cycle is a periodic rise and fall of the fission-rate, extending over a varying number of rhythms, and ending in the extinction of the race unless it is "rejuvenated" by conjugation or by changed environment.

6. Changes in the environment will revive the lagging functions during the descending cycle, as is shown conclusively by the sudden recuperation of *Oxytricha A* during July, 1902. There is every reason to believe that this "rejuvenescence" was produced by treatment with extract of beef.

7. Seasonal and temperature changes have no apparent influence on the cyclical fluctuations of vitality. Variation in temperature, however, undoubtedly affects somewhat the daily rate of division, if not directly, at least through the food supply.

8. The number of generations which constitute a cycle is not at all constant; and there is no evidence to show that duration in time is of any significance in the forms studied.

9. Periods of extreme depression of vitality are manifested on the physiological side chiefly by a greatly decreased division-rate, and by the comparative frequency of pathological divisions. Morphological changes are apparent chiefly in (1) an increased vacuolization of the cytoplasm; (2) distortion and fragmentation of the macronuclei; (3) numerical increase of the micronuclei; and finally (4) in a reduction of the ciliary apparatus.

10. Variation in the size of the infusorians during the life-cycle is marked; the organisms being very small during periods

of high reproductive activity and progressively increasing in size as "degeneration" advances. In the last couple of generations before death ensues the size is secondarily reduced by a shrinking of the cytoplasm.

11. A disappearance of one of the micronuclei occurred at certain periods of high reproductive activity.

12. These cultures strongly suggest that it is customary to regard the structure most frequently observed in "wild" Infusoria as too constant in character, and to overlook the fact that, under varying conditions, modifications may occur which are in no way abnormal.

13. Throughout the entire period of the cultures no tendency to conjugate was shown in any of the series, and experiments for endogamous and exogamous syzygies failed to produce a single case.

14. Experiments with  $\text{KH}_2\text{PO}_4$ ,  $\text{K}_2\text{HPO}_4$ ,  $\text{KCl}$ ,  $\text{KBr}$ ,  $\text{K}_2\text{SO}_4$ ,  $\text{MgSO}_4$ , and  $\text{NaCl}$  gave evidence of the extreme sensitiveness of Protozoa to solutions of electrolytes. Initial stimulation with  $\text{KH}_2\text{PO}_4$ ,  $\text{K}_2\text{SO}_4$ , and  $\text{KBr}$  in  $\frac{n}{100}$  solutions caused in each case a slight acceleration of the division-rate; while initial stimulation with  $\frac{n}{100}$   $\text{K}_2\text{HPO}_4$ ,  $\text{KCl}$ ,  $\text{NaCl}$ , and  $\text{MgSO}_4$  caused a slowing of the rate. Daily stimulation with the same solutions of each of these salts invariably caused a marked inhibition of the fission-rate. Initial stimulation with  $\text{KH}_2\text{PO}_4$   $\frac{n}{1250}$  showed no change in the rate while  $\text{K}_2\text{HPO}_4$   $\frac{n}{1250}$  produced a marked increase.  $\text{K}_2\text{SO}_4$   $\frac{n}{320}$  accelerated division; and  $\text{KCl}$  and  $\text{NaCl}$  each in  $\frac{n}{40}$  solutions, retarded it; while  $\text{KBr}$   $\frac{n}{40}$  accelerated the fission-rate. Comparison of the effects of the two solutions of each salt shows that, almost without exception, the more dilute solution produced the greater variation in the rate from the control.

15. Stimulation with  $\text{K}_2\text{HPO}_4$   $\frac{n}{1250}$  gave different results at various periods of the life-cycle, which indicates that the state of the general vitality of the culture, and also the rhythms, are factors which must be taken into account in experimental work of this nature.

16. Light has little or no direct effect on the division-rate of *Oxytricha fallax*.

LITERATURE.

- BÜTSCHLI, O., '76.—Studien über die ersten Entwicklungsvorgänge der Eizelle, der Zelltheilung und der Konjugation der Infusorien. Abh. d. Senckenb. nat. Gesellsch. Frankfurt a. M., x.
- '83.—Protozoa. Bronn's Klassen und Ordnungen der Thierreichs.
- CALKINS, GARY N., '01.—The Protozoa. Columbia University Press.
- '02, 1.—Studies on the Life-history of Protozoa. I. The Life-Cycle of *Paramœcium caudatum*. Archiv für Entwicklungsmechanik der Organismen, xv, 1.
- '02, 2. (With C. C. Lieb.)—Studies on the Life-history of Protozoa. II. The Effect of Stimuli on the Life-Cycle of *Paramœcium caudatum*. Archiv für Protistenkunde, i, 1.
- '02, 3.—Studies on the Life-history of Protozoa. III. The Six Hundred and Twentieth Generation of *Paramœcium caudatum*. Biol. Bull., iii, 5.
- '04.—Studies on the Life-history of Protozoa. IV. Death of the A-Series of *Paramœcium caudatum*. Conclusions. Journal of Experimental Zoölogy, i, 3.
- DUJARDIN, F., '41.—Histoire naturelle des zoöphytes Infusoires, comprenant la physiologie et la classification de ces animaux, etc.
- ENGELMANN, T. W., '76.—Ueber Entwicklung und Fortpflanzung von Infusorien. Morphologisches Jahrbuch, i.
- GEDDES, P., AND THOMSON, J. A., '00.—The Evolution of Sex. Second ed. Scribners.
- GREELEY, A. W., '04.—Experiments on the Physical Structure of the Protoplasm of *Paramœcium* and its Relation to the Reactions of the Organism to Thermal, Chemical and Electrical Stimuli. Biol. Bull., vii, 1.
- HERTWIG, R., '03.—Ueber Korrelation von Zell- und Kerngrösse und ihre Bedeutung für die geschlechtliche Differenzierung und die Teilung der Zelle. Biol. Centralblatt, Bd. xxiii.
- JOHNSON, H. P., '93.—A Contribution to the Morphology and Biology of the Stentors. Jour. of Morphol., viii, 3.
- JOUKOWSKY, D., '98.—Beiträge zur Frage nach den Bedingungen der Vermehrung und des Eintrittes der Konjugation bei den Ciliaten. Verh. Nat. Med. Ver. Heidelberg, xxvi.
- LYON, E. P., '04.—Rhythms of Susceptibility and of Carbon Dioxide Production in Cleavage. Amer. Journal of Physiology, xi, 1.
- '02.—Effects of Potassium Cyanide and of Lack of Oxygen upon the Fertilized Eggs and the Embryos of the Sea Urchin (*Arbacia punctulata*). Amer. Journal of Physiology, vii, 1.

- MAUPAS, E., '88.—Recherches expérimentales sur la multiplication des Infusoires ciliés. Arch. d. Zoöl. exper. et gén., 2me sér., vi.
- '89.—Le rejuvenissement karyogamique chez les Ciliés. Arch. d. zoöl. exper. et gén., 2me sér., vii.
- PETERS, A. W., '04.—Metabolism and Division in Protozoa. Proc. Amer. Acad. Arts and Sci., xxxix, 20.
- RYWOSCH, D., '00.—Ueber die Bedeutung der Salz für das Leben der Organismen. Biol. Centralblatt, xx, 12.
- SCOTT, J. W., '03.—Periods of Susceptibility in the Differentiation of Unfertilized Eggs of Amphitrite. Biol. Bull., v, 1.
- SIMPSON, J. Y., '01, 1.—Observations on Binary Fission in the Life-history of Ciliata. Proc. Roy. Soc. Edinb., vol. xxiii.
- '01, 2.—Studies in Protozoa. I. Notes on the Intimate Structure of Protozoa, as Exhibited by Intra-vital Staining. Proc. Scot. Microscopical Soc., iii, 2.
- STEIN, F., '83.—Der Organismus der Infusionsthier. Leipzig.
- STERKI, V., '78.—Beiträge zur Morphologie der Oxytrichinen. Z. w. Z., xxxi.
- TOWLE, ELIZABETH W., '04.—A Study of the Effects of Certain Stimuli, Single and Combined, upon Paramœcium. Amer. Jour. of Physiol., xii, 2.
- VERWORN, M., '97.—Allegemenine Physiologie.
- WALLENLUND, H., '01.—Inanitionserscheinungen der Zelle. Zeit. f. allg. Physiologie, i, 1.
- WEISMANN, A., '84.—Ueber Leben und Tod.
- WILSON, E. B., '00.—The Cell in Development and Inheritance. Second ed. Columbia University Press.

EXPLANATION OF PLATES.

The photographs were taken by Dr. Edward Leaming, of Columbia University, from permanent preparations stained with picrocarmin. The magnification is the same in every case and the relative sizes, therefore, represent absolute differences. The figures, unless otherwise specified, are of *Oxytricha fallax*, Culture A.

PLATE I.

Figs. 1 and 2. Two individuals in the 230th generation, period 16, April 2, 1902. (Cf. Diagram I.) The cytoplasm is vacuolated and the macronuclei are vacuolated and displaced in the cell. A characteristic "halo" is visible about the macronuclei. The individual shown in Fig. 2 has three micronuclei.

Figs. 3 and 4. Individuals in the 239th and 241st generation respectively. Period 24, June 1902. The two macronuclei in each are fused and their structure appears somewhat more homogenous than is the case in those illustrated in Figs. 1 and 2.

Fig. 5. Specimen in the 243d generation, period 25, June 24, 1902, showing an extreme case of cytoplasmic vacuolization. The nuclei are exceptionally normal for this period of the cycle.

Fig. 6. Specimen in the 246th generation, period 25, July 1, 1902.

Fig. 7. Individual in the 246th generation (A-2), period 25, July 2, 1902. The macronuclei are surrounded by a "halo" (cf. Fig. 1).

Fig. 8. Individual in the 247th generation (A-1), period 25, July 2, 1902. Note the condition of the cytoplasm.

PLATE II.

Fig. 9. Specimen in the 250th generation (A-1), period 26, July 6, 1902. The cell is shrunken and the cytoplasm considerably vacuolated. Note the somewhat reduced size and irregular contour of the cell. This is the last of the line A-1 before it was "rejuvenated."

Figs. 10 and 11. Specimens in the 255th generation, period 27, July 21, 1902. These individuals are from line A-2 which remained dividing, at this time, at the slow rate. The specimen photographed in Fig. 10 has ingested a *Trachelomonas volvocina*.

Fig. 12. Specimen in the 256th generation (A-1), period 26, July 8, 1902. This line had divided six times within the past forty-eight hours. Note the normal condition of cytoplasm and nuclei as compared with the preceding specimens.

Fig. 13. Specimen in the 287th generation (A-1), period 27, July 20, 1902. Size is reduced. Compare with Fig. 12.

Fig. 14. Individual in the 331st generation (A-1), period 29, August 7, 1902. Size is reduced. Nuclei are proportionately large.

Fig. 15. Specimen in the 409th generation, period 32, September 1, 1902. Apparently a "normal" individual in every respect.

Fig. 16. Specimen in the 542d generation, period 36, October 17, 1902. Cytoplasmic vacuolization begins to appear.

Fig. 17. Individual in the 829th generation, period 56, April 29, 1903. Nuclear fragmentation has begun.

Fig. 18. Specimen in the 853d generation, period 62, July 2, 1903. Nuclear and cytoplasmic degeneration is far advanced. The size of the cell is greatly increased.

## PLATE III.

- Fig. 19. Same as Fig. 18, Plate II.
- Fig. 20. Specimen in the 854th generation, period 62, July 4, 1903.
- Fig. 21. A double monster from A-1, 238th generation, June 16, 1902.
- Fig. 22. *Oxytricha fallax*, B-culture. Specimen in the 365th generation, August 25, 1903. Condition is normal.
- Fig. 23. *Pleurotricha lanceolata*, B-culture. Individual in the 413th generation, January 29, 1904. Late division-stage.



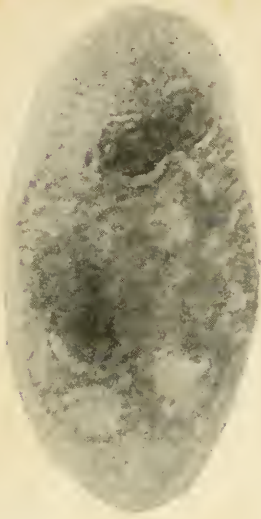

1

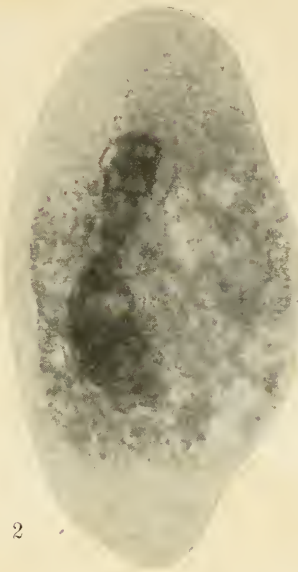

2



3



4

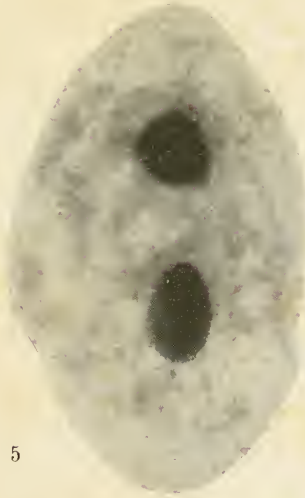

5

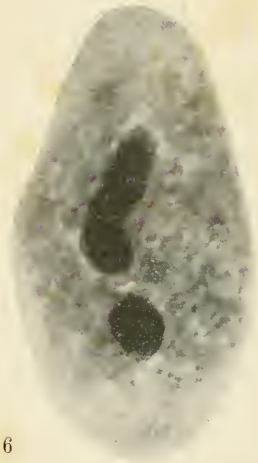

6

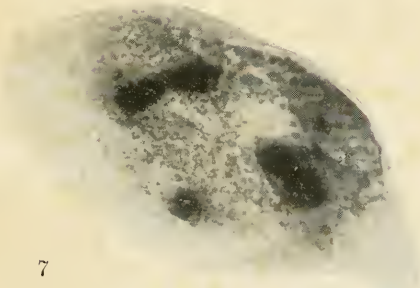

7

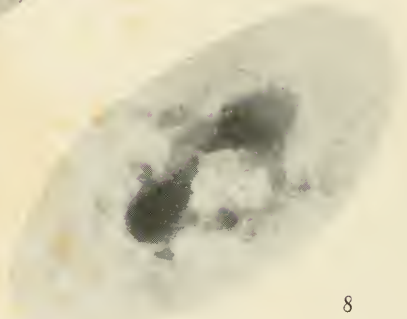

8



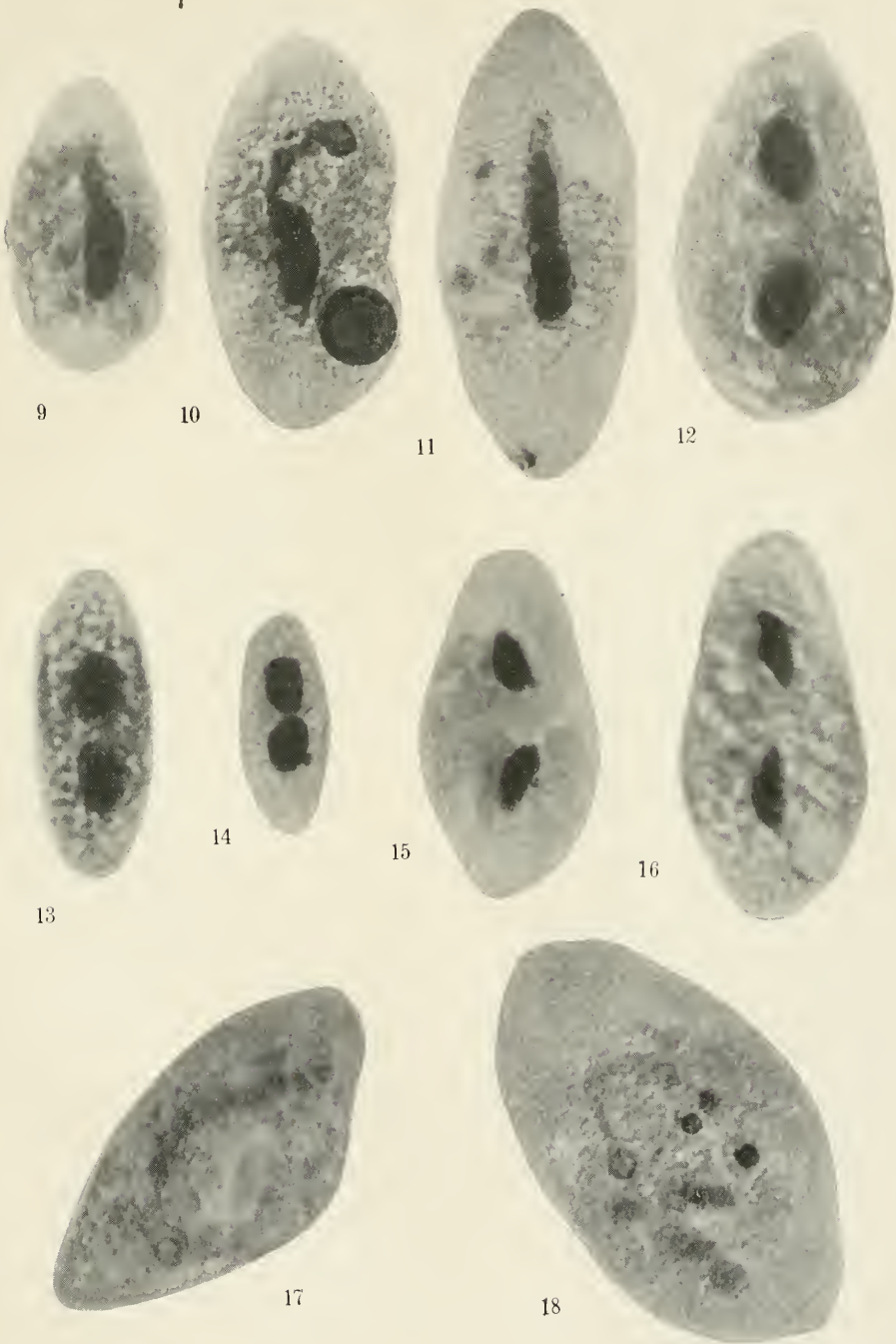





19

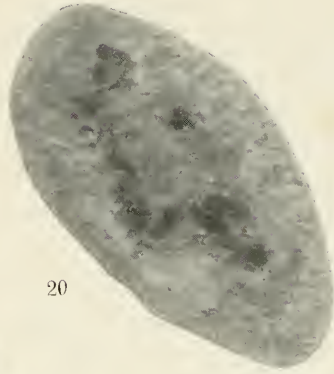

20



21

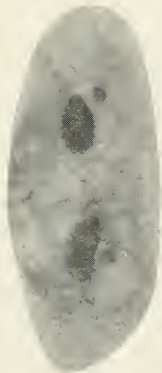

22

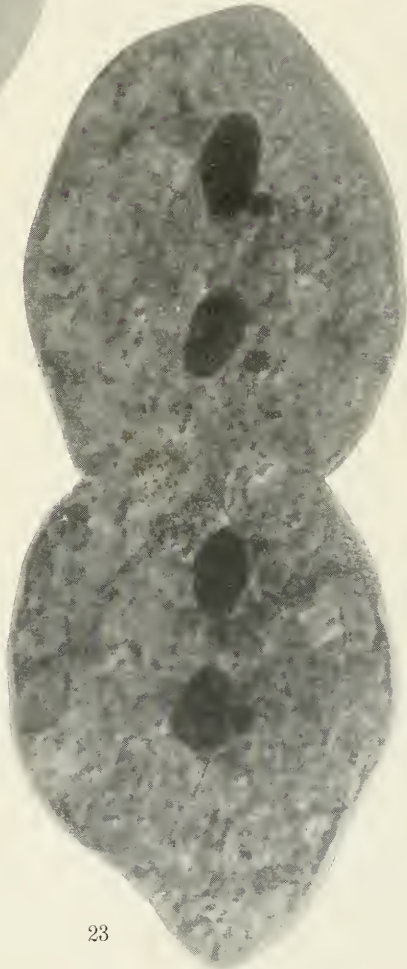

23









MBL WHOI Library - Serials



5 WHSE 02013

