

CHEMICAL WARFARE

PART VI

DEFENSE AGAINST GAS

Revision of
A. E. F. Publication No. 1433

January, 1920



WASHINGTON
GOVERNMENT PRINTING OFFICE
1920

WAR DEPARTMENT
Document No. 999
Office of The Adjutant General

WAR DEPARTMENT,
WASHINGTON, *January 31, 1920.*

The following pamphlet, entitled "Chemical Warfare, Part VI, Defense Against Gas," is published for the information of all concerned. This pamphlet replaces such parts of W. D. Document No. 705, "Gas Warfare," as are covered herein. A. E. F. Publication No. 1475, "Gas Manual," in five parts, for the present will constitute the first five parts of "Chemical Warfare," until such time as they shall be revised and published under the new title.

[062.1, A. G. O.]

BY ORDER OF THE SECRETARY OF WAR:

PEYTON C. MARCH,
General, Chief of Staff.

OFFICIAL:

P. C. HARRIS,
The Adjutant General.

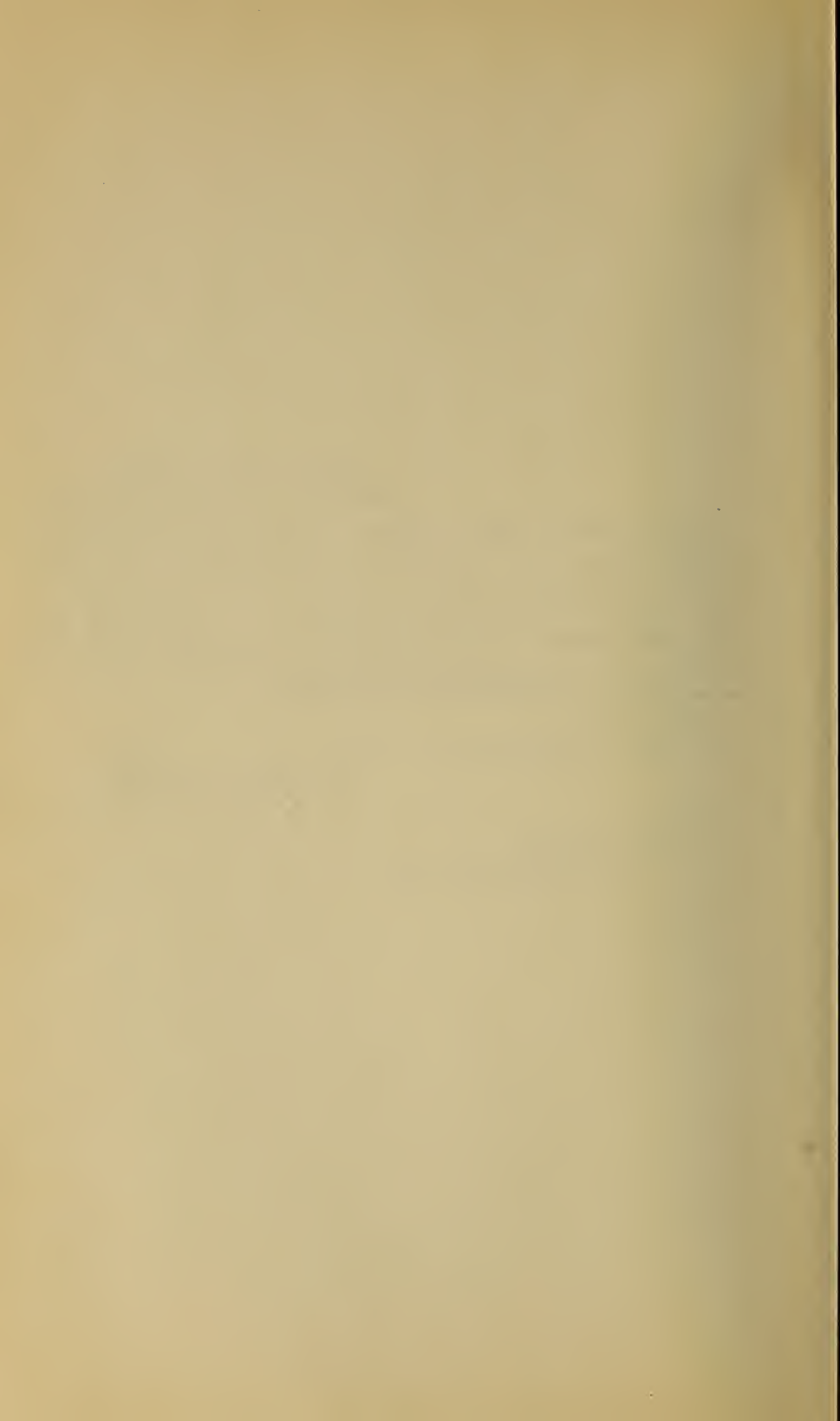
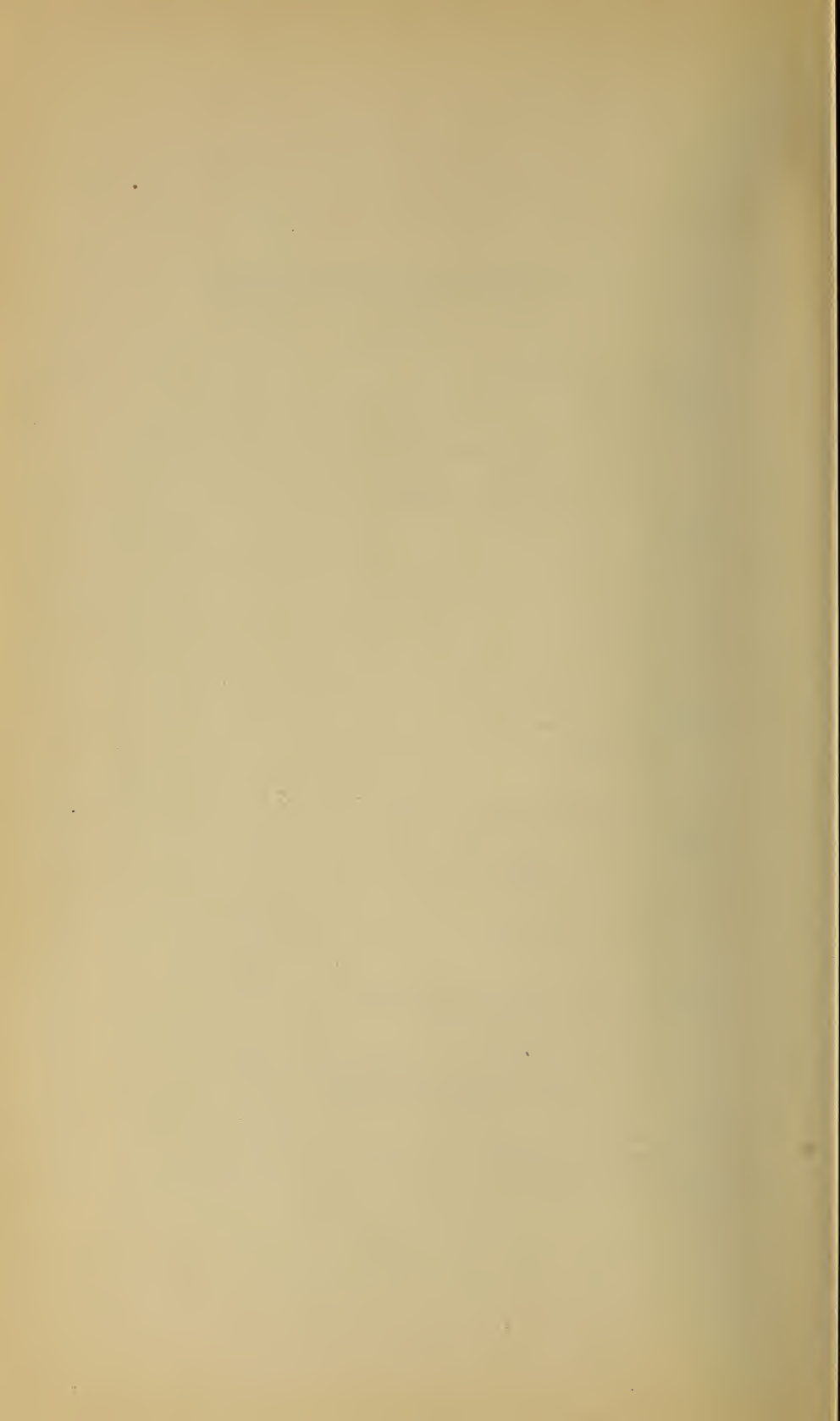

TABLE OF CONTENTS.

	Page.
I. General considerations.....	7
II. Gas attacks.....	8
General.....	8
Cylinder cloud attacks.....	9
Projector attacks.....	10
Trench mortars and artillery.....	11
Gas hand grenades.....	12
III. Warfare gases.....	12
Mustard gas.....	12
Phosgene.....	19
Diphosgene.....	20
Chlorpicrin.....	20
Arsines.....	20
Tear producers.....	21
Smoke.....	21
IV. Protection against gas.....	21
Individual.....	21
Collective.....	21
Special arms.....	24
Preparation for the use of gas.....	26
V. Gas masks.....	27
American mask, latest type.....	27
Adjustment drills.....	27
Inspection.....	29
Fitting instructions.....	29
Care of mask.....	31
Horse mask.....	34
VI. Standing orders and duties of gas officer.....	36
Divisional standing orders.....	37
Disinfecting squads.....	43
Duties of regimental and battalion gas officers.....	45
Duties of gas noncommissioned officers.....	46
Specimens for analysis.....	49
VII. Other masks.....	49
Small box respirator.....	49
VIII. Gas defense supply.....	51



DEFENSE AGAINST GAS.

I. GENERAL CONSIDERATIONS.

1. The following notes have been prepared for the guidance of officers when giving instruction in gas defense. Information on the offensive use of gas is contained in other pamphlets.

2. Gas is one of the most important weapons of modern warfare. This is due to the insidious, poisonous, and burning effects of even extremely small quantities of gas, and the further fact that large areas can be made dangerous by its use. These characteristics of gas make necessary a system of defense against it at once wide in its scope and continuous in its action.

3. There is, on the other hand, no type of warfare which can be so successfully resisted as gas. Against well-disciplined troops, violent gas bombardments have failed to secure any casualties, though any laxity always results in losses.

4. It is the duty of commanding officers to familiarize themselves with the nature of gas and the means of defense against it. Protective appliances are constantly being improved as chemical warfare develops, and when rightly used they give very complete protection against all forms of gas.

5. In warfare any substance which is used for its poisonous or irritating effect may be called a gas, regardless of whether it is a "true gas," an ordinary liquid atomized so as to form a mist, or a solid dispersed as a cloud of poisonous dust.

6. There are two groups of warfare gases, nonpersistent and persistent gases. The first group, of which chlorine is an example, consists of substances that are true gases under ordinary atmospheric conditions and which form gas clouds immediately upon opening the container in which they are stored. Those of the second group, typified by mustard gas, form vapors only very slowly unless scattered by shell explosion or warmed by the heat of the sun. *Even an extremely small amount of certain gases, if breathed for a sufficient length of time, will cause a casualty.*

7. A man some distance from a shell hole containing poisonous liquid may become a casualty through inhaling the vapor or by being burned through its action on his body, even if no shells have

fallen for several hours. It is important that this be explained so that the men may appreciate the danger of gas, and at the same time realize that there is nothing mysterious or supernatural about it.

8. In order to cut down gas casualties to the absolute minimum, the following measures must be taken:

(a) Thorough training and drill of troops in the use of protective appliances so that they can adjust them accurately under all conditions and perform all duties while wearing them.

(b) Frequent and rigid inspection of all protective equipment.

(c) Absolute obedience to regulations in regard to carrying the mask in danger and alert zones.

(d) Training all troops to recognize gas attacks.

(e) Installation of adequate gas alarms and instruction of sentries in their use.

(f) Teaching all officers and gas noncommissioned officers the properties of gases, proper methods of defense against them, and action to be taken in situations likely to arise.

(g) Practice in wearing masks for long periods.

(h) Wearing masks as long as gas is present.

Danger from gas can be greatly reduced by these means, and officers should impress this fact on their men. *Excessive casualties from gas attacks indicate laxity or ignorance on the part of officers.* A well trained, properly equipped man has no need to fear the effects of gas.

II. GAS ATTACKS.

GENERAL.

9. On the offensive, gas is employed to reduce the fighting efficiency of the enemy:

(a) By inflicting casualties, which result from surprise, ignorance, bad discipline, faulty training, and defective equipment.

(b) By compelling them to wear masks or to make use of other protective appliances, which interfere materially with the work of the troops.

10. In making gas attacks, efforts are made to liberate or generate a cloud of gas either directly upon the target or in such a position that it will be carried across the target by the wind. To accomplish this end three distinct methods are employed:

(a) *Cloud gas attacks.*—In cloud gas attacks the gas is liberated by troops along the line held by them and the cloud is allowed to drift over the target. While formerly used almost wholly on stabilized fronts, improvements in methods will in the future make this attack possible in any form of warfare and at any time when the wind is blowing toward the target.

(b) *Projector attacks*.—With the improvement of projectors and methods of handling them projector attacks may occur much oftener than heretofore and may be expected even in open warfare, unless the rate of movement be so great as to constitute a practical rout.

(c) *Bombardments with artillery or mortars*.—Due to the range of artillery, gas attacks by artillery may be made in any method of fighting and at any time, regardless of wind or weather, except that with an unfavorable wind the target must be more distant from the firing line, or a smaller quantity of gas be fired, than with a favorable wind.

In the case of cloud gas attacks, the gas is liberated in or near the front line. In the case of projector or mortar attacks, and of attacks by artillery shell, the gas is inclosed in a suitable projectile and is fired onto the target. There, by means of percussion or time fuses and a bursting charge, the shells are broken open and the poisonous material liberated. The bursting charge is varied, depending upon the liquid or solid used. The bursting charge is usually very small in the case of a liquid or liquefied gas, but in the case of solids is often sufficient to give a high-explosive effect. A liquefied gas vaporizes when the pressure is released by the breaking of the shell, while liquids and solids are either atomized, vaporized, or dispersed by the explosion of the bursting charge.

CLOUD GAS ATTACKS.

11. The gas used in cloud gas attacks is generally chlorine, phosgene, or mixtures of chlorine with phosgene or chlorpicrin. At first cylinders were dug in at the bottom of the firing trench and connected with outlet pipes that led from the bottom of the cylinder out over the trench parapet. Later they were often piled on trucks or flat cars or on the ground and fired simultaneously by electricity. When the outlet valves are fully opened, whether by hand or electrically, the liquid rushes out as a gas in two or three minutes, and mixing with the air forms a cloud. This type of cloud may vary in appearance, due to weather conditions or to smoke which may be mixed with it. It may be almost transparent, it may appear slightly green in color, or it may look like a thick mist. Other gases and methods will unquestionably be developed.

12. The cloud is carried by the wind over the opposing line and at times in valleys traces of the gas have been noticeable in the rear areas as far as 10 miles from the front line. Gas clouds usually being heavier than the surrounding air, fill up trenches and hollows and penetrate unprotected dugouts, where a dangerous concentration of gas remains long after the main cloud has passed. Such clouds tend to follow the course of valleys. Lakes or streams affect only slightly the gas or the drift of the gas cloud.

13. The chief dangers from cloud gas attacks result from the high concentration of gas at the moment of its release and from the great extent of the area which, under favorable conditions, may be covered by the gas cloud. Such attacks are very dependent on wind conditions and should not be made in heavy rains. They are best made only when there are no upward-moving currents of air; that is, on cloudy days or before sunrise or after sunset. They offer a little less chance for surprise than other forms of attack, and hitherto have often been detected by—

- (a) Noise of hammering on metal in the trenches.
- (b) Active wind observations by the enemy.
- (c) Escape of gas from cylinders hit by shell.
- (d) Raids.
- (e) Prisoners' statements.

During discharge of the gas, warning was often given by—

- (a) The hissing sound of the escaping gas.
- (b) The appearance of the cloud.
- (c) The odor of the gas before the main cloud reached the trenches.

Gas-cloud attacks are a most dangerous form of attack, and when they are made every form of gas-defense equipment is given a most severe test.

PROJECTOR ATTACKS.

14. By this method a large number of projectiles, each containing 16.5 to 30 pounds of liquefied gas, are simultaneously shot from smoothbore or rifled iron tubes dug into the ground or set in wooden racks. The propelling charges are varied according to the range desired. The electric current for firing the charges is generated by hand-driven magnetos called "exploders," each of which fires about 25 projectors. The projectiles are exploded and the gas volatilized by means of a time or a percussion fuze. By this method a heavy cloud of gas is liberated directly on the target. Projector attacks are not so dependent upon weather conditions as cloud gas attacks. Projector attacks call for the highest degree of gas discipline among the troops affected because of the surprise which is often secured and the instantaneous formation of an extremely concentrated and deadly cloud of gas. (For new use of phosgene-pumice in projectors, see par. 28.)

Warnings of an impending projector attack have been given by—

- (a) Noise of installation of the apparatus and material.
- (b) Active wind observations on the part of the enemy.
- (c) Airplane photographs of projector emplacements, new dumps, and tracks.

Not much reliance can be placed on these means of detection, as it may be expected that projectors will generally be installed and fired during the same night.

15. Warning of a projector attack has often been given by the large flash or series of flashes made when the projectors are fired, followed by a loud explosion, like that of an ammunition dump blowing up. The sheet of flames is often concealed by installing projectors behind hills so that the only warning given is the sound of the firing. Sentries should be warned to give the alarm when any sound is heard which might be interpreted as being caused by projectors. The course of the projectiles through the air may be traced at night by the trail of sparks emitted from the time fuzes. Bombs make a loud whirring noise described as being similar to the noise of partridges in flight, but in the case of rifled projector shell the noise is less distinctive, being similar to that caused by ordinary artillery shell. Twelve to 22 seconds' warning is usually given by the flash and explosion.

GAS BOMBARDMENT WITH ARTILLERY AND MORTARS.

16. Gases may be shot from trench mortars or Stokes mortars. With sufficient rapidity and accuracy of fire, it is possible to generate a heavy cloud of gas on the target. A higher degree of accuracy is attained than with projectors, and the bombardments can be continued indefinitely, whereas a projector can be fired only once during a considerable period of time. However, it is not possible by the use of mortars to develop as high a concentration in as short a time as with projectors, while the likelihood of surprise is not nearly so great.

17. The use of toxic substances in artillery shell is probably the most important method of chemical warfare. Batteries firing rapidly and accurately against some objective, such as another battery, can develop a moderately high concentration at a long range. Owing to the greater range and accuracy of artillery fire, weather conditions affect only slightly this use of gas, although a wind of high velocity or upward currents will disperse a cloud of nonpersistent gas so rapidly that very little damage will be done. Gas shells are used in various ways, according to the tactical result desired. To produce casualties, sudden bursts of lethal shell are concentrated on small targets, and in preparation for an infantry advance enormous numbers of shell containing penetrating and surprise gases are often employed. Harassing fire with persistent gases, like mustard, or with tear gases, a few shells at a time, may be continued indefinitely against permanent positions.

GAS HAND GRENADES.

18. Toxic substances find a use of minor importance in hand grenades. In this form poisonous chemicals are used for the purpose of "mopping up" recently captured trenches and dugouts.

III. WARFARE GASES.

MUSTARD GAS.

Physical and Chemical Properties.

19. Dichlorethylsulphide, known as mustard gas, is an oily liquid boiling at 423° F. On account of its high boiling point it vaporizes very slowly, and is therefore extremely persistent. It has a slight and not unpleasant odor described as being like that of mustard or garlic. It is a stable compound, being but slowly destroyed by water at ordinary temperatures, though more quickly by alkalis, such as bicarbonate of soda. Chloride of lime will destroy any mustard gas, either liquid or gaseous, with which it comes in contact. The liquid will soak into soil on which it is thrown and remain there from a week to a month. Therefore, mustard-gas shell holes should not be dug up for a considerable time after a bombardment. The liquid which remains in or above the surface layer of the soil will slowly vaporize under the heat of the sun. This vaporization will not as a rule be great enough at night or during cold weather to produce dangerous concentration of gas, but as soon as the ground is warmed by the sun, troops passing near will be in almost as great danger from the gas as at the time of the bombardment. Mustard gas also has the property of remaining on and penetrating woolen and cotton fabrics. Rubber is penetrated rather rapidly. Oiled fabrics delay penetration to a considerable extent. However, it is unwise to depend on this protection for more than a few hours.

Use in Projectiles.

20. Mustard gas was used during the world war in shells of practically all calibers, from 75-millimeter and 3-inch up to and including the 210-millimeter and 8-inch. It was used in both guns and howitzers of the calibers mentioned. The German mustard gas being quite pure, was mixed with a solvent in order to prevent its freezing and to increase the rate of evaporation. The solvents were carbon tetrachloride, chlorobenzene, or nitrobenzene. The mustard gas used by the Americans, English, and French was made by a process different from that of the Germans, and it contained sufficient impurities, mainly sulphur, to make the addition of a solvent unnecessary. Throughout the greater part of the time that mustard gas was used

the bursting charge was small; that is, about the same as for phosgene and other more volatile gases. Toward the end of the fighting what was known as the high-explosive mustard-gas shell made its appearance. The amount of high explosive in this shell was in some cases equal to about 30 per cent of the capacity of the shell. This high explosive broke the shell up very completely and scattered the mustard gas as a fine spray or mist. This not only made the mustard gas less persistent on account of the greatly increased surface for evaporation, but made the gas very deadly in those cases where the spray was breathed. The reason for this was that the amount of gas taken into the lungs in the form of a very fine spray is enormously greater than the amount taken in in the form of a pure gas. The use of this high-explosive mustard-gas shell may be expected to be far greater in any future fighting than in the past.

Summary of markings for chemical shell and properties of commonest gases.

French number.	Shell filling.	American and British code symbols.	French designation.	German designation and shell marking.	Odor.	Persistence.		Physiological effect.	Remarks.
						In open.	In woods.		
4	Chlorine (used only in cloud gas). Arsenic trichloride, 30%; stannic chloride, 15%; hydrogen cyanide, 50%; chloroform, 5%.	Red Star. Not used by A. E. F. or B. E. F.	Bertholite. Vincemite.		Chloride of lime.	10 min. 10 min.	3 hrs. 3 hrs.	Lung irritant, deadly; action immediate. Lachrymator and respiratory irritant; considered quite toxic, but in high concentrations only.	These gases are very volatile; they are vaporized equally at the moment of explosion, forming a cloud capable of giving deadly effects, but which loses more or less rapidly its effectiveness by dilution and dispersion into the atmosphere.
4B	Cyanogen chloride, 70%; arsenic trichloride, 30%.		Vitrite.			10 min.	3 hrs.	A lachrymator, respiratory irritant and lethal agent.	
5	Diphenylchlorarsine. Phosgene.	D. A. D. C. C. G.	Sternite. Sternite. Collangite.	Blue cross. Three white bands; white.	Slight. Is interchangeable with Musty hay; green corn.	10 min. 10 min.	3 hrs. 3 hrs.	Sneezing gas; nerve depressant; "respiratory irritant." Effects somewhat greater. Respiratory irritant; very deadly; action usually slightly delayed.	These gases form nonpersistent clouds of solid particles.
	Diphosgene.	Not used S. F.	S u p e r - palite.	Green cross.	Disagreeable, suffocating; musty hay.	3 hrs.	12 hrs.	Same as phosgene.	
	Phenylcarbonylamine chloride. Phosgene, diphosgene, and diphenylchlorarsine.			Green cross.	Resembles diphosgene; a little pungent.	3 hrs.	12 hrs.	Eye, nose, and throat irritant; not very poisonous. Respiratory irritant; slightly delayed action; very deadly; causes vomiting and a little lachrymation.	These gases, having moderately high boiling points, are only partially vaporized at the moment of explosion. The cloud formed upon explosion is generally not deadly, but it immediately gives penetrative lachrymatory or irritant effects. The majority of the "gas" contents of the shells is pulverized and projected in the form of a spray or fog which slowly settles on the ground and continues to give off vapors which prolong the action of the initial cloud.
7	Chlorpierin, 75%; phosgene, 25%.	P. G.		Green Cross 1.	Pungent, suffocating.	3 hrs.	12 hrs.	Slightly delayed action; very deadly; respiratory irritant; causes vomiting and a little lachrymation.	Phosgene in these mixtures has same effect as used above, if concentration is sufficiently high.
	Diphosgene and chlorpierin.			Green Cross 1.	Pungent, suffocating.	3 hrs.	12 hrs.	Slightly delayed action; very deadly; respiratory irritant; causes vomiting and a little lachrymation.	
	Chlorpierin.	P. S.	Aquinite.		Pungent.	3 hrs.	12 hrs.	Causes vomiting; respiratory irritant; tear producer.	
	Chlorpierin, 80%; stannic chloride, 20%.	N. C.			Pungent.	3 hrs.	12 hrs.	Respiratory irritant; causes vomiting; tear producer.	

9	Ethyl dichlorarsine and dichloromethylether.		Yellow cross 1 or green cross 3.	Ethereal, pleasant.	3 hrs...	12 hrs...	Nerve poison similar to diphenylchlorarsine; easily destroyed by water.
21	Bromacetone. Bromketones.	B. A.	Green cross.	Pungent.	2 days. 3 days.	<i>Persistent class.</i> 7 days. 7 days.	Lachrymator; tear producer. Tear producers; slight respiratory irritants; action immediate.
20	Brombenzyleyanide. Mustard gas (dichloroethyl sulphide).	C. A. H. S.	Yellow cross.	No odor. Slight mustard or garlic.	3 days.	7 days.	Not toxic, but most powerful lachrymator known. Respiratory irritant; eye and skin irritant; blistering agent; action delayed several hours.

These gases, having very high boiling points, are but little vaporized at the moment of explosion. A small portion of the contents of the shell is atomized and gives immediate effect, but by far the greater part is projected on the ground in the form of droplets which slowly vaporize and continue the action of the initial cloud.

NOTE.—The above figures on time of persistency are approximate only and for calm weather. Persistency is dependent to a large extent on temperature, wind velocity, and the amount of gas liberated, especially in woods or other more or less closed places. High temperatures and wind velocities decrease persistency, and low temperatures and wind velocities increase it.

Physiological Action.

21. The following points should be carefully noted in regard to mustard gas, as they, in combination with its persistence, make it the most dangerous of all. Unlike others, it has almost no immediate irritating action on the respiratory system or on the eyes, and therefore does not force a man to put on his mask. Exposure to either liquid or vapor, even in low concentration, will cause irritation of any tissue with which it comes in contact. This irritation is usually not noticed for from 3 to 12 hours after the exposure and may affect any part of the body. The worst mustard-gas cases are due to irritation of the respiratory tract, which may be serious enough to cause death. A secondary effect is sometimes pneumonia or in lighter cases bronchitis and an acute sore throat lasting for some time. Exposure of the eyes to the vapor will cause temporary blindness, which is very painful, and will last from a few days to three or four weeks, depending on the length of the exposure. The third effect, from which mustard gas derives its name of vesicant or blistering agent, is the production of painful burns on those portions of the skin with which it comes in contact, particularly the tender and moist parts under the arms and around the scrotum.

Tactical Uses.

22. Mustard gas is used rather for neutralization and harassing than as a surprise gas, because of its slow evaporation and pronounced delayed action. Its persistency is greater than that of any other gas, and hence by its use any position may be made untenable for days after it is shelled. It is particularly valuable for use against valleys and woods, because such terrain will remain infected longer than open country. It is used in general against artillery emplacements, support and reserve positions, command posts, billets, woods, communicating trenches and roads.

23. Mustard gas is used in attack only in small quantities during the three or four days preceding a large scale attack, except against those points over which it is not intended to advance. Particular care must be taken in occupying captured terrain because of the danger from gas traps. Gas shell and bombs may be left in dug-outs or farmhouses and set to explode when the locality is filled with the occupying troops. Mustard gas may be sprinkled on roads and at all points over which troops must pass. In general, all shelters will have been liberally soaked with mustard gas.

Individual Protection.

24. (a) The masks in use by the American forces give absolute protection against all but the blistering action of mustard gas. Certain special precautions in the use of the masks must be observed. Because of the slight odor and delayed action of mustard gas, troops

must be trained to put on the respirator immediately when any odor is noticed which *might* be that of gas. They must not remove the mask until all traces of the gas have disappeared. They must be trained to wear it for long periods of time and to work or fight efficiently while wearing it. Men who have been exposed to mustard gas and have been *testing for it for several hours* gradually lose their ability to detect it. On wearing the mask a short time one recovers his keenness of smell for the gas.

(b) The issue of protective clothing, such as suits and gloves, is usually authorized for special troops only.

(c) *Sag paste*.—This is a protective ointment which, if applied before exposure to the gas, will greatly diminish its effects upon the skin. The paste should be rubbed liberally in an even layer on the genital organs and scrotum, the buttocks, the armpits, and other parts of the body which perspire freely. The length of time that such an application is effective depends entirely upon the strength of the gas. Since there is no way of judging this easily in the field, care must be taken to use a sufficient quantity of the paste and to renew the application about once every 12 hours when continually exposed to the gas. It should be carefully noted that sag paste must be applied before troops enter an area that is likely to be shelled. This will have to be done on the judgment of the unit gas officer.

(d) Any portion of the skin which has been splashed by the liquid from mustard-gas shells or even moist parts that have been exposed to the vapor should be washed as quickly as possible with soap and water. Any kind of soap will answer and cold water is satisfactory. It is only necessary to work up a good lather and massage the place well with this lather. Very little water used in this way often suffices to prevent burns.

(e) If chloride of lime is available, as it should be, some of the dry powder sprinkled on the skin that is splashed with mustard-gas liquid will prevent a bad burn. The powder is to be left on the skin about 15 minutes and then washed off with water and soap if obtainable.

Collective Protection.

25. In general, *if the tactical situation permits*, the best protection against mustard gas is evacuation of all ground infected by it, and *alternative positions should be prepared or selected in advance* with that object in view. If a zone has been evacuated after a mustard-gas bombardment, sentries should be posted on all roads and paths entering this zone to warn troops away from it and to prevent their entering. Sentries should also be posted in front of contaminated dugouts in a zone otherwise free from mustard gas. If not possible

to evacuate, frequent reliefs, or protection of troops as far as possible in gas-proof dugouts, will alone prevent numerous casualties, as mustard gas will outlast the staying power of troops wearing the mask. In connection with the use of gas-proof dugouts, it should be noted that men entering such dugouts have gassed the occupants by the gas which they have brought in on their clothes, and therefore all outer clothing should be removed in the entrance to the dugout and soles of shoes treated with chloride of lime. A scraper, water, and box of chloride of lime should be kept near the entrance to each dugout. The shoes are first dipped into the water, then thoroughly rubbed in the lime, and finally washed off in the water. This precaution, if followed by thorough washing of the body, will be very effective in preventing burns. Attacks will not generally be made across areas recently heavily shelled with mustard gas.

Disinfection of Positions and Clothing.

26. After a mustard-gas bombardment the covering of shell holes with chloride of lime will render such shell holes harmless. The chloride of lime should be spaded in well, then covered with another thinner layer of lime, which is in turn covered with fresh earth. This should be done by a special disinfecting squad provided with the proper protective clothing. It is manifestly impossible in the case of an extensive bombardment to disinfect all shell holes in this way, but those near which troops pass or near dugouts should always be disinfected. Men after walking over an area infected with mustard gas will find it necessary to destroy the poison on their shoes before entering a dugout, as this liquid readily evaporates afterwards in the dugout, rendering the atmosphere extremely dangerous. Chloride of lime is placed on the ground outside of dugouts, in order that the men may use the lime to destroy the liquid that may be carried upon their shoes. There is an element of danger in the use of chloride of lime to destroy gas, due to the fact that the odor of the chloride of lime completely masks that of the mustard gas. When chloride of lime is thrown on liquid mustard gas some chlorine is given off. This will cause little annoyance. However, the heat of the reaction may vaporize some of the mustard gas which has not yet been destroyed. When large puddles of the liquid are encountered they will first be sprinkled with sand, dry earth, or ashes, to absorb the greater part of the poison before being treated with chloride of lime. Clothes which have been gassed can be disinfected by washing in running water for several days, by washing in nearly boiling water for one to two hours, by steaming for an hour, or by hanging them out in the rain. The extent of cleaning necessary and method employed will depend on the amount of contamination and conditions in the field.

PHOSGENE.

Physical and Chemical Properties.

27. Phosgene or carbonyl chloride is a liquid boiling at 47° F. with a marked odor, described as being like that of moldy hay. Because of its low boiling point it will not remain on any terrain on which it is thrown for more than a few minutes. It will form clouds of varying concentration, depending on the manner in which it is thrown over and the strength of prevailing winds. A very heavy cloud may render positions dangerous 10 kilometers ($6\frac{1}{4}$ miles) from the original point of attack.

Methods of Use.

28. Phosgene is sent over in clouds, in projector bombs, and in artillery and mortar shells. In cylinders for cloud attacks it is usually mixed with chlorine in order to form a mixed gas of high vapor pressure. It is generally used pure in the 75, 170, and 250 millimeter mortar shells and in smoothbore projector bombs. In these it is occasionally mixed with chlorpicrin. It was used a few times in long-range rifled projector shells mixed with pumice which absorbed some of the phosgene and thus retarded its evaporation, thereby making it persist for several hours. It sometimes occurs in small proportion as a decomposition product of diphosgene in artillery shell.

Physiological Action.

29. Phosgene is a lung irritant and is probably the most deadly gas used in warfare. Exposure to high concentrations for even a short time will cause severe casualties, or death, and much lower concentrations will also have serious effects. Its full effect is often delayed for some hours, and exercise after exposure to this gas will render slight casualties serious and at times fatal. Because of this effect, men who have been gassed even slightly and who have experienced no symptoms of gas poisoning must be prevented from taking any exercise whatever; otherwise serious casualties will occur.

Tactical Uses.

30. Phosgene is used entirely as a surprise gas, as high concentrations can be developed with it very rapidly. Its persistency is low, and it is therefore possible to follow up a phosgene attack with an infantry advance, without masks, after a very short time.

Defense Against Phosgene.

31. The mask gives absolute protection against this gas. Troops must be trained to put on the mask quickly and accurately, under any circumstances, and sentries must be thoroughly instructed on how to recognize phosgene attacks and to give the alarm immedi-

ately. Trenches and dugouts can be quickly rid of phosgene by means of fanning and fires.

DIPHOSGENE.

32. Diphosgene, superpalite, or trichlormethyl chlorformate, is a liquid boiling at 261° F. Its other properties and action resemble those of phosgene very closely. It can not be used in cloud or projector attacks because of its high boiling point. It was used in the World War mixed with chlorpicrin in shell of different calibers and also with diphenylchlorarsine. Phosgene usually accompanies diphosgene, due doubtless to the decomposition of the latter.

CHLORPICRIN.

33. Chlorpicrin is a colorless liquid boiling at 234° F., and hence is fairly persistent. It approaches phosgene in its poisonous effect. Even in very low concentrations it will cause lachrymation and in higher concentrations vomiting, which may necessitate the removal of the mask. The clothes of men who have been exposed to chlorpicrin are dangerous because of the gas which is carried on them, and the same precautions against gassing men in dugouts must be taken as in the case of mustard gas. Chlorpicrin was used in the World War mixed with diphosgene and also with stannic chloride. The mask gives full protection against this substance.

ARSINES.

34. Diphenylchlorarsine is a solid of extremely low volatility and is practically odorless. It is used in shell which contains in addition a large amount of high explosive. On the explosion a cloud of fine particles is formed. The cloud will cause headache and intense pain in the throat and chest, accompanied by sneezing and coughing. Vomiting and even temporary paralysis of the nervous system may finally result. It is used mainly to unnerve men and prevent their adjusting their masks quickly or to prevent their keeping them on after being adjusted. It is used also for direct neutralization through the production of the above painful symptoms. The effects of this gas when used alone disappear quickly. The mask gives absolute protection, but must be put on immediately. Diphenylcyanarsine is similar in its action and rather more effective. It is used in shell in the same manner as diphenylchlorarsine.

35. Ethyldichlorarsine is a moderately volatile liquid, also used in shells in the same manner as phosgene or diphosgene. It is analogous to diphenylchlorarsine in physiological action, exerting a destructive effect upon the respiratory tract along with the nerve poisoning. It is rapidly destroyed by moisture.

TEAR-PRODUCING GASES.

36. Various gases, such as bromacetone and brombenzylcyanide, are used as tear-producing agents. They are heavy liquids with high boiling points and are used usually along with deadly gases in all the various forms of projectiles. They are capable of producing blinding tears in very low concentrations and are particularly effective in forcing men to put on their masks. For this reason they are valuable as harassing gases. They have also a noticeable poisonous effect when used in large quantities. They are quite persistent, especially brombenzylcyanide. The mask gives absolute protection against them. Chlorpicrin, in addition to its toxic properties, is of value as a tear producer.

SMOKE.

37. Smoke is used, either in the form of a cloud or emitted from shell and bombs. Smoke may be used with gas or between gas clouds and should therefore be considered unsafe until investigation has determined the absence of gas; it may also be used alone to distract attention from a real discharge of gas, and in general for preventing observation, for instance, as a screening barrage, or for blotting out machine-gun nests, blinding gunners and observers, and for various other purposes.

IV. PROTECTION AGAINST GAS.**INDIVIDUAL.**

38. Every man whose duty carries him to the zone of the advance will be provided with a mask. No other mask than the one issued may be carried or worn. For description, care, fitting, inspection, drill, etc., for the mask see paragraphs 64-89, inclusive.

COLLECTIVE PROTECTION.

39. The following precautions are included under this head:

- (a) Wind observations to ascertain when conditions are favorable for a hostile gas attack.
- (b) Adequate systems of sentries and alarms.
- (c) Gas proofing of dugouts and cellars.
- (d) Clearing gas from dugouts and trenches.
- (e) Disinfecting contaminated ground and clothing.
- (f) Precautions regarding food and water.
- (g) Protection of weapons and equipment.

Wind Observations.

40. Such wind observations will be made within the division as the division commander, on the recommendation of division gas officer, may decide to be necessary. The results of such observations should be reported to company commanders, who will in turn notify

the division gas officer when the wind is favorable for enemy gas attacks. (For further information on this subject, see paragraphs 142-146.)

Alarms.

41. Experience has shown that numerous casualties occur through failure to warn men promptly when the enemy makes a gas attack. *Officers are responsible that arrangements are made for the communication of the gas alarm to everyone under their command in the shortest possible time.* The need for quickness in giving the gas alarm is imperative; a few seconds delay, particularly in the case of projector attacks, makes a great difference in the number of casualties. *Sentries must be posted over all men sleeping in dugouts.* Whenever there is danger of projector attacks men should be prevented from sleeping within 1,500 yards of the enemy front line, if tactical requirements permit. On detecting the presence of gas, sentries shout "Gas," put on their masks, and immediately spread the alarm in every possible way.

42. The method of giving the alarm varies with the nature of the attack. In cylinder and projector attacks it is necessary to warn troops over considerable areas, while the effect of gas-shell bombardments is much more local, making it necessary to alarm only troops in the immediate neighborhood of the bombarded area. As an alarm for gas attacks any device may be used which gives a loud and distinctive noise and does not require the use of the lungs. Improvised alarms, such as church bells and empty shell cases, are suitable, as well as Klaxon horns, wooden rattles, and steel triangles. Light signals which do not conflict with other signals already in use may be approved by the division commander on the recommendation of the division signal officer for use as gas alarms. Commanders of companies on the move should make sure that a sufficient stock of portable alarm devices is always on hand. Instructions with regard to gas sentries and alarm systems are given in "Standing orders," paragraphs 115-118.

Protection of Dugouts and Cellars.

43. The protection of dugouts against gas has proven of great value, especially in the case of gases of high persistency, which necessitate the wearing of the mask for long periods in infected areas. The entrances to all dugouts and shelters of sufficiently good construction within the "Alert" zone should be provided with two gas-tight doors, or with two curtains of gas-proof material with a space of several feet between them, thus forming a gas lock. Each curtain should be fitted so as to give a tight joint over the whole frame of the door, stopping all drafts. The methods of proper

PLATE I



th
at
14
Al

fa
O,
ni
sh
al:
pr
tie
W
ve
if
se
th

at
tr
m
in
al
di
vi
ab
Li
us
de
m
st
w
in
Pr

ve
ne
ar
cc
ge
sp
cu
fr

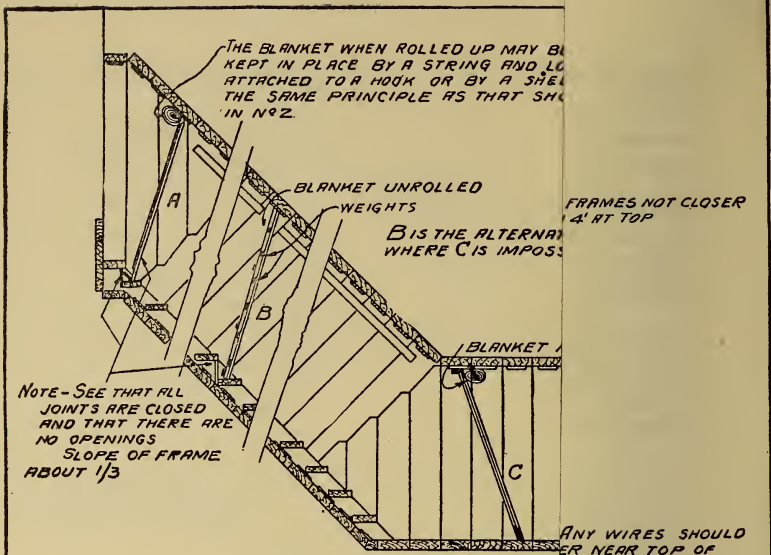

No. 1
ARRANGEMENT OF GAS BLANKETS

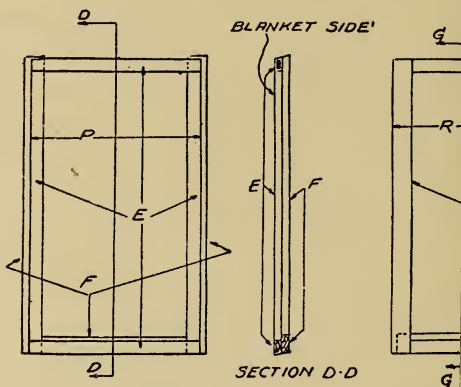

No. 4
INTERIOR BLANKET FRAME
USED AS IN "C" OF NO. 1 AND IN NO. 3
E = 1x4 BLANKET COVERED
F = 1x6 PLAIN.
P = 2'-8" TO 3'-8"

EXTERIOR BLANKET FRAME
USED AS IN "A" OF NO. 1 AND IN NO. 3
H = 1x4
K = 1x6
L = 1x6
R = 4' FO

R.E.M. 2-23-18.

dugout protection are shown on the accompanying plate. Not only should dugouts and cellars be provided with frames and blankets, but care must be taken that the cracks between the frames and the earth or rock walls are made gas-tight. Curtains should always be kept moistened or oiled and rolled up when not in use. Unless this is done the curtains are useless. All dugouts which have been made really gas proof should be posted with the sign "Gas proof." In commanding officers', medical, and signal dugouts particular care should be taken to provide this protection so that officers and men can work during gas attacks without wearing masks.

Precautions to be observed in dugouts in case of gas attacks:

- (a) Lower curtains immediately.
- (b) Wake all sleeping men.
- (c) Put out all fires.
- (d) Stop up any holes, flues, or chimneys.
- (e) Prevent passing in and out as much as possible.
- (f) In case of passage in or out, only one man must pass through at a time. Only one curtain must be raised at a time, and curtains must be lowered as quickly as possible.
- (g) Men entering from gassed areas must remove outer clothing and leave it in the gas lock.

Clearing Gas from Dugouts, Trenches, and Similar Depressed Places.

44. After a cloud, projector, or other heavy gas attack some of the gas will remain in unprotected dugouts, trenches, and hollows in the ground. Any gas present in the air may be removed rapidly by ventilation. In shallow dugouts and trenches, fanning with coats or empty sandbags will produce a sufficient draft for this purpose, but all dugouts are cleared most rapidly and effectively by means of a fire. In dugouts provided with a single exit, the best results are obtained if the fire is placed in the center of the floor of the dugout. In those provided with two or more exits, the fire should be placed at the inner end of the exit passage farthest from the wind.

45. After bombardment with mustard gas, in addition to gas remaining as described above, some of the liquid will remain on the ground near the shell craters, on the floor and walls of dugouts and emplacements that have received direct hits, in piles of straw and rubbish, and in straw mattresses, clothing, and equipment. This liquid may continue to give off gas for long periods and every possible means must be taken to destroy it immediately. Pumice, or other absorbent, soaked in gas and fired in shell should be covered deeply with earth (not chloride of lime), or the position evacuated until it ceases to give off gas.

GAS BLANKET ARRANGEMENTS

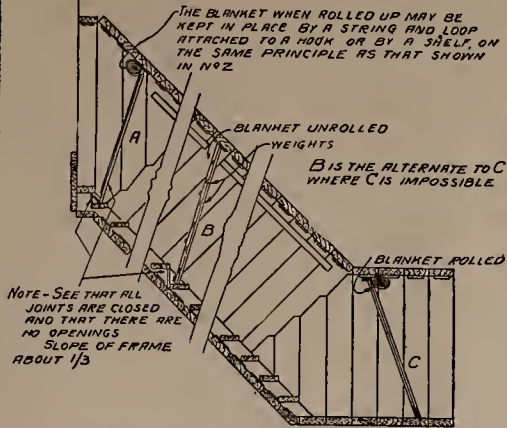

TWO FRAMES NOT CLOSER THAN 4' AT TOP

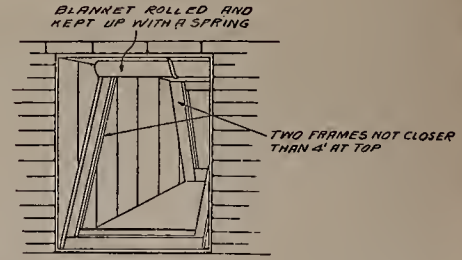
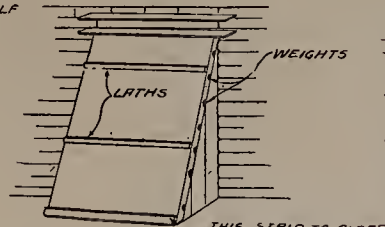
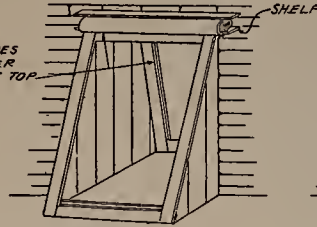

No 2
PROJECTING ENTRANCE
USED SOMETIMES IN DRESSING STATIONS TO AVOID NARROWING PASSAGE

No 3
HORIZONTAL GALLERY

No 1
ARRANGEMENT OF GAS BLANKETS

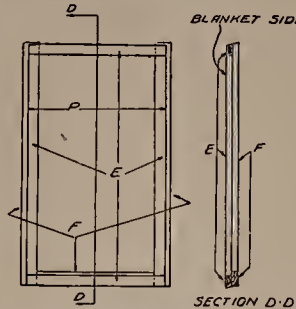

No 4
INTERIOR BLANKET FRAME
USED AS IN 'C' OF NO 1 AND IN NO 3
E - 1x4 BLANKET COVERED
F - 1x6 PLAIN
P - 2'-8" TO 3'-8"

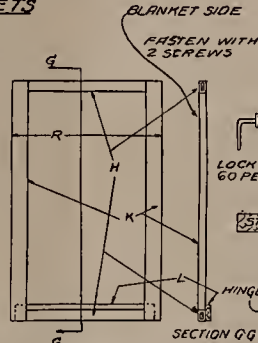

No 5
EXTERIOR BLANKET FRAME
USED AS IN NO 2
H - 1x4 BLANKET COVERED.
K - 1x6 BLANKET COVERED
L - 1x6 PLAIN
R - 4" FOR DRESSING STATIONS

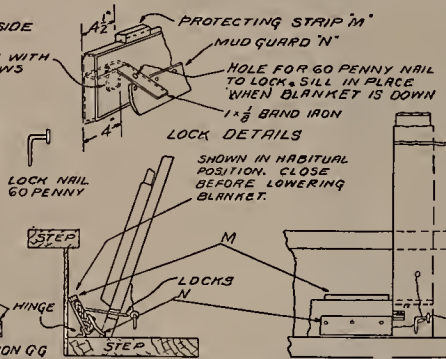

No 6 (OPTIONAL)
DETAIL OF INTERIOR FRAME BOTTOM
WHEN FRAME IS USED AS IN 'A-B' OF NO 1
M - 1x2 PLAIN, PROTECTING STRIP
N - LEATHER OR RUBBER MUD GUARD

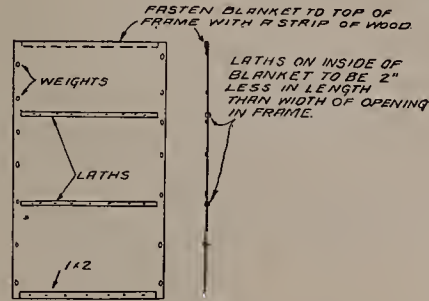

No 7
BLANKET
WHEN USED ON INTERIOR FRAME BLANKET MUST BE 3" WIDER THAN DIMENSION 'P' OF NO 4. WHEN WITH EXTERIOR FRAME 4" WIDER THAN DIMENSION 'R' OF NO 5

NOTE: ANY WIRES SHOULD ENTER NEAR TOP OF FRAME
BLANKET COVERED DOORS MAY ALSO BE USED TO SUPPLEMENT THE BLANKET CURTAINS.

LATHS ON INSIDE OF BLANKET TO BE 2" LESS IN LENGTH THAN WIDTH OF OPENING IN FRAME.

Precautions with Reference to Food and Water.

46. Cases have been reported of ill-effects caused by food which has been exposed to gas. All food and water should be kept covered. Food that has an unusual taste or odor after a gas attack or bombardment should not be eaten. Very frequently casualties have resulted from the use of contaminated water from shell craters. All water from shell craters should be regarded as dangerous until proved to the contrary, and every effort should be made to use water only from sources reported safe after inspection by the proper authorities.

Protection of Weapons and Equipment.

47. Many gases, particularly phosgene and chlorine, have a powerful corrosive action on metals. This action is greatly assisted by moisture, which dissolves and retains the gas so that corrosion continues until the surface is cleaned. Mustard-gas liquid will corrode brass. Metal surfaces which are covered with mineral oil are not affected, provided they are cleaned and reoiled after exposure.

SPECIAL ARMS.**Artillery.**

48. Artillery is very liable to bombardment with gas shell. Owing to the suddenness of shell attacks and the long periods for which the neighborhood of a battery may be affected, it is essential that the following points be noted:

(a) All men must be thoroughly trained to stop breathing and adjust their masks accurately before breathing; to wear their masks for long periods, and to serve the guns while wearing them.

(b) Signalers must take all the precautions laid down in paragraph 52.

(c) Special care must be taken to protect all dugouts near battery positions against gas.

(d) Alternative positions must be selected in advance, and mustard areas promptly evacuated whenever the tactical situation permits.

Artillery, Rifles, and Machine Guns.

49. All unpainted metal parts should be kept well oiled, and as soon as possible after exposure to corrosive gas, should be washed in boiling water containing a little soda, and then be reoiled. Splashes of mustard should be brushed with dry chloride of lime.

Ammunition.

50. When possible, ammunition should be stored in tight boxes or in recesses in the parapet, protected by a curtain moistened with water or oil. After an attack, corroded rounds should be cleaned, oiled, and expended as soon as possible. Unboxed hand and rifle

grenades should be kept covered. All safety pins and working parts, especially those made of brass, should be kept oiled to prevent their setting from corrosion by the gas.

Engineers.

51. Tunneling companies are reminded that the mask does not afford protection against mine or explosion gases, and oxygen apparatus should therefore be used in mining. The entrances to mine shafts must be protected from gas by blanket curtains in the manner already described for dugouts. Division gas officers are provided with detectors for poisonous mine gases.

Signal Corps.

52. It is essential that telephone operators should be able to work as much as possible during a gas attack without wearing masks or helmets. Signal dugouts, therefore, must be particularly well protected against gas. Telephone operators must be especially proficient in using their instruments when wearing masks. The headpiece of the receiver will be worn over the mask. Linemen must receive plenty of practice in carrying on their work while wearing masks, both at night and in the daytime.

Signal and Telephone Equipment.

53. The only effective method of preventing corrosion of electrical apparatus during a gas attack is to prevent the gas from reaching it, and the best way to do this is to have signal offices thoroughly protected against gas. As the corrosive effect on damp instruments is very much greater than on dry instruments, the shelters should be kept as dry as possible.

54. During a gas attack, telephones must be kept in their leather cases, and unless the buzzer key is being used the leather flap must be kept down, leaving only the cords with the receiver and hand-set out of the case. The backs of switchboards and buzzer exchanges must be kept closed. All apparatus, such as magneto telephones, test boards, spare instruments, etc., which it is not essential to have in the open, should be well covered up with cloths, blankets, or coats.

55. After a cloud or projector attack with chlorine or phosgene, telephone apparatus that has been exposed to gas should be treated as follows:

56. The ends of the wire should be removed from terminals and cleaned by being scraped with a knife. Terminals, exchange plugs, and all exposed metal work should be cleaned first with a damp and then with a dry cloth. This process should be repeated after 12 hours have elapsed. Instruments which have been splashed with mustard gas should be brushed with dry chloride of lime and later washed with soap and water. The internal portion of the instrument

should not be interfered with. If an instrument has been kept closed or covered up, it is very unlikely that internal portions will have suffered; but if these portions shown signs of corrosion, the instruments should be sent back to corps or division headquarters to be dealt with by an instrument repairer.

Protection of Carrier Pigeons.

57. When the gas alarm is sounded, pigeons should be placed in the special gas-proof boxes and bags provided for that purpose, or in gas-proof shelters. If for any reason the birds can not be protected from the gas, they should be liberated at once. Where circumstances permit, gas-proof boxes or bags should always be kept near baskets containing birds, and should be regularly inspected. Pigeons can be utilized during a gas attack. Experience has proven that they will fly up through any gas cloud, as such clouds seldom rise above 30 to 50 feet from the ground, but it is imperative that the bird should be exposed to the gas for as short a time as possible. The message and carrier should therefore be prepared and, if possible, fastened to the pigeon's leg before the bird is exposed to the gas. Twenty seconds should suffice to fix a carrier and liberate a bird.

Preparation for Use of Gas.

58. Whenever the extensive use of gas in any form is contemplated, corps and division gas officers will always be consulted. The expert advice which these officers are able to furnish will not only be of value in helping to assure the success of an offensive, but may prevent injury to our own troops through ill-timed use of gas or the use of a kind of gas unsuited to the conditions. The tactical uses of the different gases vary greatly and thorough knowledge of their properties is essential to a realization of their full tactical values.

59. For cloud attacks it is advisable that before gas is discharged all troops except those whose presence is considered absolutely necessary, should *be withdrawn from the line along which the gas is to be liberated*. Any officer or man who has special orders to remain should wear his mask. All troops will be cleared from any places in front of that line.

60. All troops in any part of the line within 600 yards of the nearest point where the gas is being discharged should put on their masks.

61. In all attacks measures will be taken for the protection of the troops only after consultation with the officer in charge of the gas operation.

62. If troops advance after a gas attack, it must be remembered that the gas may hang about for some time in long grass, shell holes, and hollows, and for four to six hours in the enemy's shelters. Dug-outs should not be occupied until they have been thoroughly venti-

lated and the absence of gas established. This is equally necessary with regard to shelters which have been penetrated by gas from shell or bombs. For other precautions in connection with occupation of territory, see paragraph 23.

Gas Shell and Gas Bombs.

63. These may be stored alongside other ammunition. In the event of leakage, all but mustard-gas shell should be expended if possible, or buried in the ground 5 feet deep. Mustard-gas shell should be buried. They should not be thrown into water, and care must be taken that they are not buried near the sources of water supply. All rescue work and disposal of leaky shells should be carried out by men wearing masks. In the case of mustard gas, protective gloves and suits should be worn.

V. GAS MASKS.

AMERICAN MASK, LATEST TYPE.

Drills.

64. The following drills are designed to teach officers and men to adjust their masks accurately and quickly. The drill must be so thoroughly mastered that all will protect themselves instantly and almost automatically upon hearing the gas alarm.

65. *Drill "A."*—*To bring the mask to the "Alert" position.*

(1) Slung position: Mask with sling over right shoulder. Satchel hanging on left side with press buttons closed and next to the body.

(2) Gas alert position: Being at "slung" position: (1) *Mask Alert*. Place the rifle between the knees. Slip the left arm back through the sling and bring the satchel around to the front of the body. Open the flap of the satchel. Take out the whipcord with the right hand and pass it through the metal loop on the right-hand side of the satchel. Raise the satchel to the chest with the left hand so that the slack of the sling falls over the back, pulling it down with the right hand and holding it there. Then take the sling in the left hand, and with the right pass the cord through the sling, then through the metal loop on the left side of the satchel and fasten it tightly with both hands after adjusting mask to proper height on the chest. Fold flap over top to protect mask from moisture, but do not fasten.

Alternative position, especially when pack is slung: Being at "slung" position: (1) *Mask Alert*. Place the rifle between the knees. Slip the left arm back through the sling and bring the satchel to the front of the body. With the right hand grasp the metal hook at the left of the satchel and with the left hand reach behind the neck for the metal eyelet on the sling, pull down and fasten the two together. Open the flap and take out whipcord with right hand.

Pass it through the metal loop on the right of the satchel, then around the back and secure it to the metal loop on the left of the satchel.

66. *Drill "B."*—*Drill "by numbers" to obtain complete and accurate adjustment of the mask from the "Alert" position.*

This drill will be alternated with one without the numbers to insure as quick an adjustment as possible, in which practice in holding the breath will be included. The drill must be practiced until complete and accurate adjustment can be made quickly by all. Start with the mask in the "Alert" position. The helmet is worn with the strap adjusted at the back of the head. One end of a lanyard is attached to the left loop of the helmet and the other is passed around the left shoulder.

Being at "Alert" position with helmet adjusted: (1) *By the Numbers.* (2) *Gas.* Stop breathing. Place the rifle, if unslung, between the knees. Insert the thumbs under flap and open satchel. Seize the facepiece with the right hand. *Two.* Bring the facepiece smartly out of the satchel to the height of the chin, holding it firmly in both hands with the fingers extended outside, the thumb inside at the binding midway between the two lower straps of the head harness. Stick out the chin. *Three.* Bring the facepiece forward, digging the chin into it. With the same motion, guide the straps of the harness over the head with the thumbs, knocking the helmet off backward. *Four.* Grasp the outlet valve tightly between the fingers, to prevent the passage of air through it, and blow vigorously into the mask, completely emptying the lungs. *Five.* Feel around the edge to make sure the facepiece is well seated. Correct adjustment and head harness. *Six.* Replace helmet. Resume the attention.

67. *Drill "C."*—*To adjust mask from slung position.*

Being at slung position: (1) *Gas.* Stop breathing. Place the rifle, if unslung, between the knees. Pull the satchel around until it hangs in front of the body. Unfasten the flap and adjust the mask as in practice "B," allowing the satchel to hang by the rubber tube. Replace helmet, and at once proceed to adjust the satchel in the "Alert" position, as in practice "A."

68. *Drill "D."*—*Drill to teach method of testing for presence of gas.*

Mask being adjusted: (1) *Test for Gas.* Take a moderately full breath. With the right hand pull the facepiece slightly away from the right cheek, hold the breath, and sniff gently. If gas is smelled, readjust the facepiece, grip the outlet valve between the fingers and thumb, and breathe out hard.

69. *Drill "E."*—*To remove the facepiece.*

Having tested and found no gas: (1) *Remove.* (2) *Facepiece.* Insert the first two fingers of the right hand under the facepiece of

the chin, placing the thumb on the metal guard of the exit valve, bend the head forward, at the same time removing the facepiece with an upward motion of the right hand.

NOTES.—(a) Care must be taken to remove the mask without undue stretching of the elastic.

(b) Folding facepieces: The facepiece should be folded flat (no part tucked inward) and the elastic bands should be folded against the outside of the facepiece on one side.

(c) After all drills the eyepieces should be rubbed with anti-dim, leaving a thin, transparent film of the composition on the glass. The facepiece should be wiped dry, folded correctly and put away in such way that the rubber outlet valve is not bent.

70. Drill "F"—*Inspection.*

The mask being at slung position: (1) *Prepare for inspection of masks.* Place the rifle between the knees. Slip the left arm back through the sling and bring the satchel around to the front of the body. Open the flap of the satchel. (2) *Inspection.* (3) *Masks.* Examine the satchel and sling, make sure that metal hook and clasp and metal loops at each side are securely fastened. Remove canister and hold under left arm, the tube and facepiece hanging over the arm. Examine the interior of satchel to see that wire platform and anti-dim are present and that whipcord is in good condition and free from knots. In latest model there is no platform. *Two.* Examine inlet valve at bottom of canister. Examine the canister for rust spots and weak places by pressing lightly with the fingers, beginning at bottom and working to the top. Watch carefully for holes in soldering at top of canister. See that flexible tube is properly fastened to the canister and to the metal elbow tube and is free from obvious defects. *Three.* See that the metal elbow tube is securely connected to facepiece and that outlet valve guard is not loose. Make sure that the outlet valve is in good condition, has no dirt or sand in it, has no tears, and is connected properly to elbow tube. *Four.* Examine the facepiece inside and out. See that chin rest is secure, that there are no pinholes or breaks in the fabric, that air passage to eyepieces is in proper condition and not torn away from fabric, that eyepieces are securely fastened in the facepiece. Examine the head harness and make sure that it is firmly attached to binding. *Five.* Adjust mask to face to test valves. Hold canister in left hand. Grasp outlet valve between fingers to prevent passage of air through it, and breathe gently in and out a few times. The inlet valve, if working properly, should vibrate back and forth. Test outlet valve by putting a kink in breathing tube to prevent the passage through it of air and attempt to draw air into the facepiece. If the outlet valve is in proper condition it will not

be possible to draw in any air. Remove masks. *Sic.* All men with defective masks step forward one pace. Others replace canister in satchel, taking care not to twist facepiece into wrong position, and return masks to slung position. (Note: After inspection men should be given drill (B) once, so that it can be seen whether all canisters have been correctly replaced in satchel.)

71. Masks will be inspected daily in the alert zone, and at least twice weekly in the danger zone. (See pars. 108 and 109.) They must always be inspected before proceeding into the alert zone.

72. It is the duty of every officer and noncommissioned officer, and is especially the duty of the gas officers and their assistants, to make sure that these inspections are carefully carried out. Only by constant supervision can officers be certain that masks and other gas-defense appliances are properly and regularly inspected. The importance of this can not be too greatly emphasized. A mask must always give complete and absolute protection. Its condition can only be determined by constant and careful inspection.

General Points on Training with Mask.

73. When training men in the use of masks the following points are of importance:

(a) Mask drill should be combined with ordinary infantry drill and physical drill, including arm and leg exercises, leapfrog, and double-time. The time of practice while wearing the mask need not exceed 15 minutes at first, but it should be gradually extended. This drill should be in heavy marching order.

(b) Practice in bombing, rapid loading and aiming, judging distance and rifle firing, should be carried out while men are wearing masks.

(c) Officers and noncommissioned officers will receive the same training as the men and, in addition, will be practiced in giving orders while wearing their masks.

(d) It must be realized that troops in the line always carry the mask, and that practice in the rear should take this into account. Every effort must be made to approximate actual warfare conditions. Every opportunity will be taken to accustom men to carrying on their usual duties with the mask adjusted. It is often necessary during and after a gas attack for men to wear their masks for six or eight hours, or even longer when a highly persistent gas, such as mustard gas, is used.

(e) Practice and drill in use of gas-defense appliances should be carried out as continuously as tactical conditions will permit. This applies especially to troops which return to the line after having been in rest areas, and to troops in which the incorporation of men incompletely trained in gas-defense measures make such training very essential.

Description of the Mask.

74. The mask consists of a metal canister filled with a mixture of charcoal and chemical granules, connected by a rubber tube to an impervious facepiece. Air is drawn in through the inlet valve, which consists of a circular rubber disk fitted on a stud in the center of a perforated metal plate. Any poisonous gas is absorbed by the granules in the canister. The purified dry air passes into the facepiece, playing over the eyepieces, and keeping them clear. Air is expired through the outlet valve, the inlet valve closing in order to prevent air passing through the canister. If the inlet valve does not close properly, expired air passes into the canister, causing deterioration of the chemicals, discomfort to the wearer, and dimming of the eyepieces.

75. The facepiece is held in position by a head harness of self-centering construction, which keeps it firmly against the face without discomfort. The complete mask is carried in a satchel which is divided into two compartments, one of which holds the canister and the other the mask. The canister rests on a wire platform which raises it from the bottom of the compartment and allows the free access of air. In latest model there is no platform.

Fitting.

76. Masks are made in five sizes.

- No. 1. Very small.
- No. 2. Small.
- No. 3. Medium.
- No. 4. Large.
- No. 5. Very large.

When masks are issued they should be most carefully fitted. In some cases it will be necessary to change the length of the elastic by means of the buckles. When the fit of the mask appears satisfactory, it must be tested in tear gas and the test repeated every month where practicable. If possible, the test should be made in the gas chamber every time a battalion comes out of the line.

77. Men should remain in the tear gas for five minutes, moving about and talking to make sure that the fit of the mask is good.

78. When the fit has been tested, each man should write his name, but not his organization, on the lower part of the front of the satchel as worn in the "Alert" position to insure that he shall not exchange his mask for another that may not fit him.

Care of Mask.

79. The most serious causes of damage to masks are:

- (a) Entry of water into the canister spoiling the chemicals.
- (b) Injury to the facepiece.
- (c) Injury to the outlet valve.

80. Masks must be protected from water as far as possible, and rough usage must be avoided. Nothing will be carried in the satchel, except the mask and anti-dimming outfit; small articles of any kind often cause damage to the mask.

81. The inside of the facepiece should be wiped before it is put away, otherwise damage is caused by the rusting of metal parts, and by the rotting of the stitching.

82. To prevent freezing of the outlet valve during very severe frost, two or three drops of glycerin should be inserted through the slits at the bottom of the valve by means of a match or stick of wood. Supplies of glycerin are kept by division gas officers for this purpose. Half a pint (8 ounces) should be sufficient for 1,000 masks. The inlet valves at bottom of canisters are not affected if kept dry. If moisture has entered and frozen, the outlet valve may be removed if necessary, thawed, wiped dry, and replaced. The inlet valve must not be treated with glycerin.

Life of Canister.

83. When canisters are issued, they will be painted with the number of the month of issue. They will then be replaced after the lapse of a certain number of months. They will usually become ineffective through mechanical damage before they become useless chemically. The chemicals in the canister will slowly lose their efficiency, even when nothing but pure air is breathed through them. This is due to the fact that the moisture in the air gradually cakes the granules, increases their resistance, and lowers their absorptive power.

Replacement of Canister.

84. When the canister of the mask is defective owing to wet, rust, or other damage, or has been breathed through for 40 hours in gas, and the mask is otherwise in good order, the canister should be replaced by a new one by a gas noncommissioned officer. Tools for detaching canisters are provided and should be kept in charge of a gas noncommissioned officer.

Removal of Old Canisters.

85. In changing canisters great care must be taken to avoid damaging the rubber tube. Remove the tape on the wire. Turn up the twisted end of the wire at right angles to the tube. Press on point of the "tool for detaching canister" under a single strand of wire near the twisted end. On pressing over the tool the wire will be cut by the sharp edge inside the ∇ . Remove the wire. Insert both points of the ∇ under the rubber; then, with the handle of the tool at right angles to the tube, move the tool around the neck to loosen the rubber from the metal. On continuing with an upward movement the tube will be detached.

Fixing of New Canister.

86. Remove the plug of cotton waste from the neck of the new box, moisten the neck and slip the rubber tubing over it so that the neck is completely covered, taking care that the facepiece is in the correct position relative to the canister.

87. To bind the tubing with string, proceed as follows (see fig. 1): Rub the string with beeswax or cobbler's wax, if available. Make a loop at one end "A" of the string. Lay it along the tube and parallel to it. Wind the remainder of the string tightly round the tube at

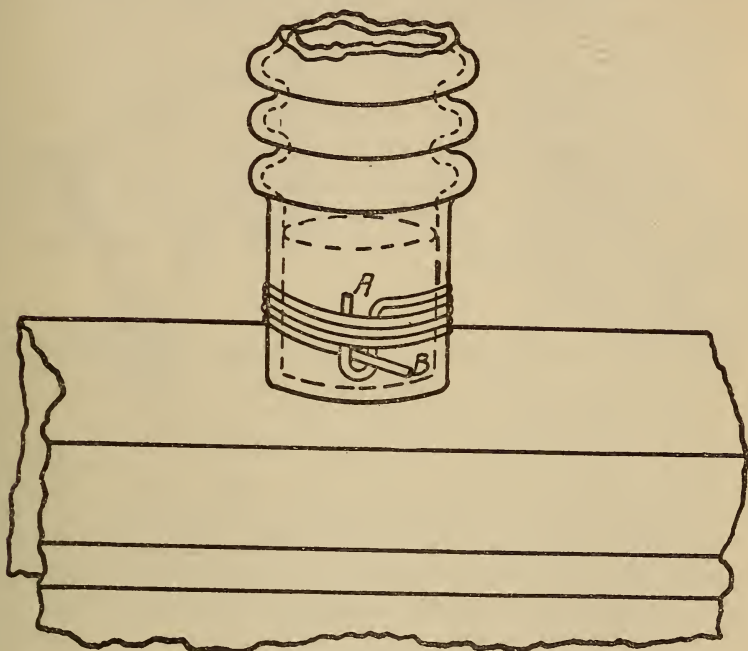

FIGURE 1.

least four times. This holds the loop in position. Pass the end "B" through the loop, and then fix it by pulling the loop tight from "A." Tie "A" and "B" together with an ordinary square knot. The string binding must be below the ridge in the neck of the canister. Test the junction to see that it is secure and gas tight.

Anti-Dimming Outfit.

88. This is carried in the satchel, and contains a stick of an anti-dimming composition and a piece of soft rag. Occasionally at inspection, and always after each wearing of the mask, the inner surfaces of the eyepieces should be cleaned and dried, a little of the composition rubbed on with the finger, and the surface rubbed with a soft rag until the film of composition is smooth and thin and nearly clear.

Minor Repairs.

89. Small perforations in the facepiece can be repaired by applying pieces of adhesive plaster both inside and outside the mask. Masks so repaired should be exchanged as soon as possible.

HORSE MASK.**General.**

90. In choosing locations for stables and horse lines, if within shell range, high, sloping, treeless ground is preferable as less likely to hold gas. Horses should not be allowed to stand on or be ridden over areas that have been heavily shelled by mustard gas, as the skin of the horse is more sensitive than that of man to the effects of this gas. They should not be allowed to eat grass that has been contaminated with mustard gas, or drink from infected shell holes. Horses exposed to mustard gas should be washed all over as soon as possible with soap and warm water, especially around the mouth, anus, and sexual organs. Horses must be practised in wearing the mask, as they will otherwise resist protection, and cause delay and annoyance in emergencies.

Description.

91. The horse mask consists of a flannelette bag with a canvas mouthpiece which goes into the horse's mouth and keeps the flannelette from being bitten through. The bag is provided with an elastic band which passes around the opening so as to draw the mask close to the face when in use. The upper side of the mouth of the flannelette bag is furnished with a small unbleached calico patch by which the mask is attached to the noseband of the bridle or halter when in the "Alert" position and while in use. Inside the bag and attached to the canvas mouthpiece there is a canvas frame which is stitched on to the bag in such a way as to prevent the material's being drawn into the nostrils when the mask is in use. The whole is folded and carried in a canvas case provided with a flap, secured by three press buttons, and having two straps at the back by means of which the case is attached to the bridle or halter.

Method of Use.

92. Horses can stand a higher concentration of gas than human beings without serious injury, and it is not, therefore, necessary to protect them against cloud gas attacks when they are a considerable distance back from the trenches. Nor is it usually necessary to protect their eyes. The mask is primarily intended for use on transport animals when they are sent to the vicinity of the trenches with supplies and ammunition. In the case of gas-shell attacks, horses should be protected wherever the shelling is heavy.

Carrying Horse Mask When Not Immediately Required.

93. When not required for immediate use the horse mask can be conveniently carried on the supporting strap of the breast harness as shown in figure 2, or if a zinc wither pad is worn, still more conveniently inside this pad. If a collar is used in place of the breast strap, it can be carried in the channel of the collar, where drivers often carry a sponge. However carried, the case is steadied by being strapped on either side to the metal ring on the supporting strap, and its flap should be passed under this strap, between it and the wither pad, and buttoned as in the "Alert position."



FIGURE 2.



FIGURE 3.

Alert Position.

94. When horses are to be sent up to the trenches, before starting, the transport or other officer responsible should have the masks adjusted in the "Alert position," as follows:

(a) The flap of the mask case is unbuttoned and slipped under the noseband of the bridle or halter from below upward.

(b) The two straps at the back are also passed under the noseband and secured to the cheek pieces of the bridle, above the metal D on each side.

(c) The small unbleached calico patch on the upper side of the mouth of the mask is buttoned on to the noseband of the head collar so that the mask is ready to be slipped on immediately in the event of a gas attack.

(d) The cover of the case is then closed over the noseband, and the mask is thus protected from rain, and held in position on the noseband. Figure 3 shows a mask in its case carried in the "Alert position."

Wearing in Gas.

95. The horse mask being carried in the "Alert position" is adjusted for use as follows:

(a) The flap of the case is unbuttoned and the mask removed, leaving the case attached to the cheek pieces of the bridle and lying flat on the face.

(b) The mouth of the bag is drawn down over the upper lip and upper teeth with one hand on each side of the mouthpiece, slipped into the mouth, and drawn well up to the angle of the lips.

(c) The elastic band is seized on either side close to the mouthpiece, and pulled outward so as to draw the mouth of the bag tight around the upper jaw, above the nostrils, and is then slipped over the poll.



FIGURE 4.

96. The mask is then in position and the animal may be worked in it without difficulty or undue distress. The bit and reins are not interfered with in any way. This is shown in figure 4.

Replacement in Case.

97. In folding the horse mask and replacing it in the case ready for use the following points should be observed:

(a) The canvas mouthpiece should be wiped as clean as possible.

(b) The flannelette bag should be held with the canvas mouthpiece underneath and the elastic band placed over the top of the bag in such a way that when the canvas patch is buttoned on to the noseband the elastic band has simply to be passed straight up over the face and over the poll. The bottom end of the mask should then be tucked in and rolled up over the elastic band to make a neat roll for insertion in the canvas case.

98. A double feed bag filled with straw, moss, or leaves saturated with sodium bicarbonate solution will make a fair emergency mask.

VI. STANDING ORDERS AND DUTIES OF GAS OFFICER.

99. The division commander will be responsible for the proper training and instruction of his command in gas defensive measures. The presence or absence of gas casualties following a gas attack will indicate the efficiency of the gas training in each division.

The Chemical Warfare Service will provide the division and corps gas officers with suitable samples of the various kinds of gases, especially those of most frequent use, for instructing the personnel in the

determination of the presence of gases. These samples will be prepared in such form that they may be easily transported without the necessity of increasing the allowance of transportation authorized for moving gas supplies.

When in training areas, quantities of various gases will be supplied for the purpose of infecting areas and shell holes to produce actual conditions of warfare.

The following forms for orders and instructions for gas defense within a division are published as suggestions for the information of those concerned. They are generally applicable to a tactical situation in which the battle line has become stabilized and the troops are occupying an organized trench system. For the varying conditions of open warfare the orders and instructions should be modified to meet the special situations.

TYPICAL DIVISIONAL STANDING ORDERS FOR GAS DEFENSE.

BULLETIN No. _____, HEADQUARTERS, _____ DIVISION,
 _____, 19__.

Organization.

100. Commanding officers of all units are held responsible that all the antigas appliances for protecting their men are maintained in perfect condition, and that everyone under their command is thoroughly trained in the use of these appliances, and in all measures which may affect safety against gas, including determination of the presence of gases and the identification of gas attacks.

101. Battalion, regimental, and division gas officers and their assistants are appointed to aid in seeing that all antigas measures are efficiently carried out. It shall be their duty to bring any deficiency in gas discipline or protection to the notice of the proper commanding officer.

102. A gas officer will be appointed by the unit commander for every regiment, for every battalion, and for separate units; a gas noncommissioned officer will be assigned as assistant to each of these gas officers, and two gas noncommissioned officers will be appointed for each company. All gas officers and gas noncommissioned officers will be relieved from all duties which might interfere with their duties as gas officers. These gas officers and gas noncommissioned officers, as well as other officers and noncommissioned officers chosen for their replacement, will be selected on account of their special qualifications. They will be required to take a course of training to fit them for their duties.

103. Regimental and other commanding officers should consult their gas officers before relieving the gas noncommissioned officers

serving them in order that other noncommissioned officers, properly instructed, may be selected as replacements.

104. The commanding officers of units will be responsible, not only for the gas discipline of attached troops, such as machine-gun companies, detachments of engineers and field signal men operating within their areas, but will also be responsible for the gas training of these troops, and will see that they receive training in gas defense equivalent to the training given their own units.

105. Gas noncommissioned officers in such attached troops will be reported to the gas officer of the unit to which they are attached (battalion or regimental). In case of detachments which are smaller than a platoon, and which have no gas noncommissioned officer of their own, one of the gas noncommissioned officers of the unit with which they are being rationed, will be assigned to act as gas noncommissioned officer for such detachment in addition to his duty with his own unit.

Training and Inspection.

106. In addition to training at the schools and in the training areas, masks should be worn at least four hours each week, during the usual drills and other duties performed by the troops. Once each month all combatant troops should wear masks for four consecutive hours. Mask drill should include the adjustment of the mask while the helmet is worn and also the adjustment and wearing of the mask in the dark.

107. Masks, alarm systems, protected dugouts, and such other gas defense measures as may exist under varying conditions within a divisional area of a division in the field will be inspected twice each week by the proper gas officers. In the "Alert" zone company commanders will provide for similar daily inspection by the gas noncommissioned officers. Any deficiencies will be called to the attention of the company commander concerned, and also of the battalion commander. As many dugouts as possible will be made adequately gas proof. No dugout curtains or other devices apparently providing protection against gas will be maintained in dugouts *which are reported as not adequately gas proof.*

Gas Zones.

108. In the field there will be defined in the fighting area of an army two zones to be known as "Alert" and "Danger" zones.

109. The *approximate* extent of these zones will be as follows:

The "Alert zone" will include the area within 2 miles of the front line, together with areas especially subject to shelling with gas, such as all active battery positions and other similar points, villages, crossroads, and convenient concentration points for troops, to be designated by the division gas officer.

The "Danger zone" will include the area between 2 and $6\frac{1}{4}$ miles back of the front line.

110. *Within the alert zone* all persons will wear the mask in the "Alert" position. Every man will be clean-shaven, except that a mustache may be worn, while the hair will be kept short in accordance with paragraph 285 of United States Army Regulations. Masks will not be removed from the person even for sleeping. A sufficient number of sentries must be posted to awaken all men quickly in case of a gas attack. *Masks and all gas defense appliances will be inspected daily in this zone* under the supervision of gas noncommissioned officers. Horse masks will be worn in the "Alert" position.

111. Within the danger zone, troops will carry their masks at all times, except when asleep, in which case the masks will be within immediate reach. Masks and gas defense appliances will be inspected three times a week under direction of gas noncommissioned officers. Horse masks will be worn in the "Carry" position over all equipment.

112. Sentinels and military police will be instructed to allow no person to pass without complying with all rules relating to the wearing of masks. They will report all cases of infringement of the above orders, and copies of these reports will be furnished to the regimental or divisional gas officers.

113. "Alert" and "Danger" zones will be conspicuously marked by each regiment in such manner as to attract the attention of persons entering them.

114. When not carried in the "Alert" position, the mask will be carried in the slung position; that is, over the left hip, the sling passing over the right shoulder. Nothing will be worn so as to interfere with the immediate shifting of the mask to the "Alert" position.

Gas Alarms.

115. An efficient system of gas alarms will be provided throughout the "Danger" zone, and especially in the "Alert" zone. This will include Klaxon horns, rattles, and triangles, together with other signals approved for this purpose by the division commander on recommendation of the division gas officer. These alarms will be used solely for the purpose of giving warning in case of a gas attack. When necessary, civil authorities within divisional areas will be warned by division headquarters.

116. Any person becoming aware of the presence of gas or of an impending gas attack will give alarm by means of the alarm signals or by calling "Gas." Anyone who knowingly gives a false gas alarm will be tried by court-martial.

Gas Sentries.

117. All sentries will act as gas sentries, and if necessary, *special gas sentries* will be posted in order that the alarm may be promptly and properly given. *Special gas sentries* will have definite areas to alarm in the event of a gas attack. Two sentinels for each area will be posted at night. When deemed necessary one of them will wear the mask completely adjusted. They will relieve each other in the wearing of the mask every hour. All working parties of 10 or more men will have a gas sentry posted. All sentries, traffic control men, and military police, when on duty, will act as gas sentries, and will be provided with suitable alarm devices when necessary. Sentries will be posted over all men sleeping and all men in dugouts or shelters, and each sentry will be definitely responsible for the group assigned to him. The loss of a few seconds in giving gas alarms may increase very greatly the number of casualties. In case of gas attack, sentries will shout "Gas!" put on their masks, and then spread the alarm. If possible, sentries in the "Alert" zone should be placed in positions overlooking the enemy lines to detect the characteristic flash which accompanies a projector attack. Sentries should be carefully instructed in methods of detecting the various forms of gas attacks, such as the white cloud in cloud attacks, and the flash, loud explosion, and whirring of projectiles in a projector attack. As frequent false gas alarms will eventually cause troops to disregard an alarm, gas sentries shall be carefully selected and thoroughly instructed so that false alarms will be reduced to a minimum.

118. Any concentration of troops within 1,500 yards of the enemy lines should be avoided, unless the tactical situation so requires. Within this area every precaution must be taken to avoid giving information to the enemy of localities in which troops are concentrated, since such points of concentration are chosen as targets for projectors.

Intelligence.

119. All intelligence indicating that a gas attack is probable should be communicated immediately to the division and corps gas officers, together with such copies of airplane photographs and intelligence reports bearing on the subject as may be available. Airplane photographs of enemy lines available at various headquarters should be examined for possible projector emplacements and copies of those received from sources other than division or corps headquarters should be sent at once by courier to such headquarters. Gas officers and noncommissioned officers will make observations of wind and weather conditions with a view to ascertaining when conditions are favorable for direct enemy gas attacks and also whether there be a

possibility of danger of gas drifting from bombardments within near-by sectors.

Liaison.

120. Immediate reports of gas attacks and of heavy bombardments of any kind must be made to the unit gas officer and the division gas officer. In order that casualties may be reduced, it is necessary that there be no delay in notifying gas officers of such attacks. In order to guard against inflicting casualties on our own men, the division gas officers will be notified (see par. 58) of any proposed extensive use of gas in operations by our own troops. In advances, the advance units must take steps to warn the support and reserves of any dangerous areas containing gas. Battalion gas officers will indicate such areas on maps or by reference, and communicate with battalion gas officers to their rear.

Action During and After a Gas Attack.

121. At the instant that any gas alarm is given, masks will be immediately put on and will be worn until the order to remove masks is given by an officer acting upon the advice of a gas officer or gas noncommissioned officer. In the case of isolated groups and in the absence of a gas officer, the order to remove masks will be given by the noncommissioned officer in charge, who will report this action promptly to the nearest officer. In case the gas attack is followed by an assault of enemy infantry *not* wearing masks, masks may be removed without formal order. Any officer or man who fails to put on his mask when warned by a gas officer or gas noncommissioned officer of the presence of gas, or by a general gas alarm, or who removes his mask without proper authority, should be disciplined. If a person under such circumstances becomes a casualty, he should be considered as wounded "not in the line of duty."

122. As soon as a gas alarm is heard, blanket curtains of protected dugouts and cellars will be properly adjusted, *fires* in such dugouts *put out*, and *all flues and vents tightly closed*. The organization attacked will at once notify battalion headquarters and troops on the flank. Battalion headquarters will in turn notify regimental headquarters and the regimental gas officers. Regimental headquarters will notify divisional headquarters of all gas attacks. Additional spreading of the alarm will take place when necessary.

123. No one will enter a gassed area into which he is not obliged to go in line of duty, while those who are within a gassed area will refrain from all movement and conversation except such as are required by military necessity.

124. When the tactical situation permits, troops not on duty should be allowed to remain in gas-proof dugouts, *and to remove*

their masks, if the dugout is entirely free from gas. An additional sentry must then be posted inside the dugout at each entrance until the area is free from gas. *All unnecessary movement and talking must cease.* In case of a cloud gas attack all bodies of troops or transport on the move should halt and working parties cease work until the gas cloud has passed. Likewise, if a relief is in progress, units should stand steady as far as possible. Supports and parties bringing up ammunition and grenades will only be moved up if the tactical situation demands.

125. As soon as possible after or during a gas attack, gas officers and gas noncommissioned officers will determine whether a "persistent" or a "nonpersistent" gas is being employed. When the tactical situation permits, a position extensively bombarded by the most persistent gas, namely, mustard, must be temporarily evacuated.

126. If mustard gas is used, the area is dangerous for at least one or two days, and sometimes much longer. (See Persistency table, pp. 14-15.) *Unless the tactical situation forbids,* an area subjected to such a gas attack should be promptly evacuated for a period of three days, or until pronounced safe by the divisional or regimental gas officer. If practicable, the division gas officer will be consulted. The evacuation should be made upwind from the shelled area when possible. For this reason alternative positions should be selected in advance, and all the necessary preparatory steps should be taken to accomplish a rapid and orderly change to such positions in case of necessity.

127. In case it is necessary to continue occupation of a position shelled with mustard gas, masks will be worn continuously. Men must not be permitted to sit or lie upon contaminated ground, and such other precautions as may be practicable must be taken to avoid contamination of the body or clothing. To accomplish this frequent reliefs should be established. After a gas attack, gas officers will take immediate steps to clear and disinfect gassed positions. (See par. 26.) They will report when the position is safe. As long as the slightest odor of mustard gas is detected, the position must be considered dangerous. It is especially to be noted that the odor of mustard gas in slight concentrations is not unpleasant, and that the gas produces no irritation for several hours. During a mustard-gas attack, precautions must be taken to avoid contamination of dugouts from the clothing and especially from the shoes of men who enter.

128. Men who have been even slightly gassed will be treated as casualties, and withdrawn promptly from the gassed area with the least possible exertion to them. It is especially important, in the case of a mustard-gas attack, that fresh clothing be available and

that the clothing be changed and the men be given a bath with soap and water as soon as practicable.

129. After a gas attack, food supplies which have been exposed should be thoroughly inspected, and any food suspected of contamination by gas should be condemned. Many casualties have been caused by the use of water from shell holes. Regardless of whether recent gas attacks have occurred, all water from shell holes must be regarded as contaminated, and must never be used for any purpose whatsoever.

130. Frequently gas attacks are carried out in waves or salvos at variable intervals, *therefore, a sharp lookout will be maintained for a repetition of a gas attack.* When the tactical situation permits, troops which have been subjected to gas attacks will be withdrawn. Commanders of units relieving one another are responsible that all the gas defense stores are handed over and received for by the respective gas noncommissioned officers of the units.

TYPICAL DIVISION ORGANIZATION OF DISINFECTING SERVICE.

(For official circulation only.)

HEADQUARTERS ——— DIVISION,
—————, 19—.

BULLETIN No. ———

131. In order to provide the most efficient means for the purification of ground which has been shelled with "mustard gas" special disinfection squads shall be designated and trained by each regimental or battalion gas officer for this purpose. These squads shall be organized in the various units according to the tactical employment of these units, as follows: Each squad will be under the immediate direction of the gas noncommissioned officer of that unit. Except in case of "mustard-gas" shelling, the men composing this squad shall be free to perform their regular duties. This does not apply to the gas noncommissioned officers who shall be assigned no duties which might interfere with their duties as gas noncommissioned officers. These men shall, however, spend such time as may be necessary to make them proficient in their work, according to the discretion of the regimental gas officer. The duties of these disinfecting squads will be:

(1) To disinfect "mustard-gas" shell holes with chloride of lime, or other disinfectant, and to cover the hole so treated with earth.

(2) To bury leaking gas "duds."

(3) To mark the location of uninjured gas "duds" and transmit that location to the regimental gas officer.

(4) To carry out infected equipment and clothing from "mustard-gas" infected barracks or dugouts, when an evacuation has been ordered.

132. The organization of these disinfecting squads shall be as follows:

(1) Divisional headquarters: 1 gas noncommissioned officer and 4 men.

(2) Infantry regiment:

(a) Regimental headquarters: Regimental noncommissioned officer and 4 men.

(b) Each battalion: Battalion noncommissioned officer and 6 men.

This squad may, if necessary, be split into two or more groups at times, to work under the direction of the company gas noncommissioned officer. The machine-gun company attached to a regiment will be taken care of by the disinfecting squad of the battalion in whose area it is located.

(3) Artillery regiment:

(a) Regimental headquarters: Regimental gas noncommissioned officer and 4 men.

(b) Each battalion headquarters: Battalion gas noncommissioned officer and 4 men.

(c) Each battery: Battery gas noncommissioned officer and 4 men.

(4) Engineer regiment:

(a) Regimental headquarters: Regimental gas noncommissioned officer and 4 men.

(b) Each battalion headquarters: Battalion gas noncommissioned officer and 4 men.

(c) Each company: Company gas noncommissioned officer and 4 men.

(5) Machine-gun battalion:

(a) Each battalion headquarters: 1 battalion gas noncommissioned officer and 4 men.

(b) Each machine-gun company: 1 company gas noncommissioned officer and 4 men.

(6) Trench mortar battery: (a) Battery gas noncommissioned officer and 4 men.

133. Field hospital, ambulance, and signal companies and other units attached to the division will be looked after by the disinfecting party of the unit in whose area they are operating.

134. The equipment for each man in the disinfecting squad, in addition to the mask, will consist of a suit of special oiled clothing and two pairs of oiled gloves.

135. Casualties from mustard gas can be avoided if proper precautions are taken. As immediate disinfection is necessary to pre-

vent casualties, every effort will be made to expedite the arrival of a disinfecting squad at a shelled area.

By command of General _____:

(Signed)

_____,
Chief of Staff.

Official:

(Signed)

_____,
Acting Adjutant.

DUTIES OF REGIMENTAL AND BATTALION GAS OFFICERS.

Typical Memorandum.

136. (1) Report all gas shelling promptly, giving time, location, weather, wind, and number, size, and kind of shells used, and any casualties reported.

(2) Report immediately any mustard-gas shelling in your area.

(3) Report promptly all changes in gas personnel.

(4) Report name, rank, and organization of all officers violating standing orders for gas defense.

(5) Insist on daily inspections of masks in "Alert" zone and twice weekly in "Danger" zone. Check up these inspections personally to be positive they are being carried out.

(6) Make sure by frequent inspections and tests that alarms in your area are adequate and in working order.

(7) Frequent instruction of all sentries is mandatory. They must be thoroughly familiarized with all their duties. They must know all standing orders of gas defense. They must know how to detect a gas attack, how and when to give the alarm and when to awaken sleeping men over whom they may be posted.

(8) Make sure that no men in your area are permitted to sleep without being near a sentry who knows where they are.

(9) Question and instruct all gas noncommissioned officers frequently, reporting those (by name, rank, and organization) you consider incapable, those who neglect their work, and those who have too many other duties to perform.

(10) Make sure that when a man loses his mask or when he turns one in for replacement that has been *rendered unserviceable through carelessness or by intention*, the new one issued is charged against his pay account.

(11) Make sure that you know all units in your area.

(12) Submit brief report each week covering work you have done during the week as gas officer, and, in addition, nature of other duties performed by you and the amount of time required for same.

(Signed)

_____,
Regimental (or Battalion) Gas Officer.

DUTIES OF COMPANY GAS NONCOMMISSIONED OFFICERS.

137. They will assist officers at the inspection of masks, taking particular care to see that each man's satchel is marked with his own name. They will assist in making such local repairs as are possible, and in training men in the use of gas defense appliances generally.

Under the company commander they will have charge of all gas defense stores, as follows:

(a) *Alarm devices.*—Inspect daily and see that sentries posted at them know how they should be used.

(b) *Gas-proof shelters.*—See that the blanket doorways fit and are kept in good condition.

(c) *Stores of fuel for clearing shelters.*—Insure sufficient supply for clearing all dugouts, to be maintained under company arrangements.

On relief they will assist the company commander in taking over all gas defense stores. The company gas noncommissioned officers should accompany the advance party and take over gas stores (by daylight, if possible).

They will make wind observations as directed by the division commander on recommendation of the division gas officer, and will report any change of wind to the company commander. (See pars. 142-145.)

138. During or after the attack the noncommissioned officer must note down in writing as much information regarding the attack as possible. (See par. 147.)

139. After a gas-shell bombardment, if the use of a new gas is suspected, the gas noncommissioned officer should take samples of earth contaminated with the suspected gas. Such samples should be handed to the division gas officer through the company commander, with notes as to position from which sample was taken.

140. They will instruct gas sentries in their duties.

141. They will report breaches of gas discipline to their commanding officer.

Instructions to Gas Noncommissioned Officers for Making Wind Observations and Furnishing Reports.

142. Gas noncommissioned officers will make to company commander such wind observations and reports as may be directed by the division commander. These reports will be oral unless otherwise ordered. In order to make wind observations the following points must be attended to:

143. *Wind vane.*—A simple wind vane should be set up. The vane must have as little friction as possible, so that a wind under 2 miles per hour will turn it. A little post at the top of the vane should carry a strip of linen 5 inches long by three-fourths inch

wide, by the movements of which the strength of the wind can be judged. The vane must be set up sufficiently high to get a true observation (e. g., 18 inches above the top of the dugout, etc.). Correct orientation should be obtained by getting north by the north star and south by the sun at midday.

144. *Direction of wind.*—Before reading the direction of the wind from the vane the observer should gauge the approximate direction by noting the course taken by smoke, etc. Direction of wind must

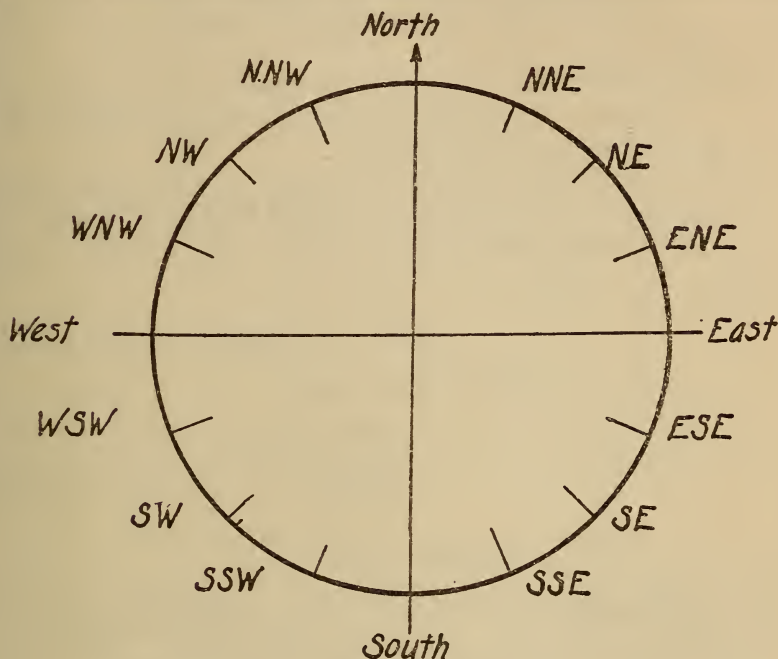

FIGURE 5.

be stated in points of the compass. The points of the compass to be used are shown in figure 5.

145. *Strength of wind.*—This may be judged from Beaufort's scale.

Beaufort's No.	Speed in meters per hour.	Observations of natural objects.	Behavior of flag on top of vane.
0	0	Smoke straight up.....	No movement.
1	2	Smoke slants.....	No movement.
2	5	Felt on face.....	Slight.
3	10	Paper, etc., moved.....	Three-quarters up.
4	15	Bushes sway.....	Up and falling often.
5	20	Tree tops sway, wavelets on water.	Up; falling less often.
6	30	Trees sway and whistle.....	Up and flapping.

146. *Warning available.*—The following simple calculation determines the number of seconds which it will take for a gas cloud to move over a given distance. Double the distance (in yards) and

divide by speed of wind (in meters per hour). Example: 100 multiplied by 2 divided by 10 equals 20 seconds.

Instructions to Gas Noncommissioned Officers for Reporting on Hostile Gas Attacks.

147. During and after a gas attack the gas noncommissioned officer should note down in writing as much information as possible on the following points:

- (a) Strength and direction of wind and general weather conditions.
- (b) Times at which the gas wave or gas shell bombardment started and finished.
- (c) Exact position and nature of place affected by gas or gas shell.
- (d) To what extent telephone dugouts, covered gun and machine-gun emplacements, etc., were affected.
- (e) The approximate number of gas shells used and their caliber.
- (f) The position of unexploded shells and fragments of shells, etc.

148. The following form will be used for making reports on gas attacks:

FORM No. 1.

HEADQUARTERS _____,
CHEMICAL WARFARE SERVICE.

Report on gas attack.

Serial No. _____
 (Date of report) _____
 Corps _____
 Division _____
 Unit _____ Location * _____
 From _____ M. _____, 19____, to _____ M. _____, 19____
 Method of attack (shells, cylinders, projectors) _____
 Number of projectiles _____ Caliber _____ Gas used _____
 Wind direction ____ Velocity, ____ M. P. S. † Temperature ____ Humidity ____
 Character of terrain (woods, sloping ground, ravine, swamp, etc.) _____
 Area of terrain and length of front affected _____
 Number of troops exposed _____
 Duds found at (coordinates) _____ Number _____ Caliber _____
 Markings _____
 Total casualties including deaths _____ Total deaths _____
 Lung cases ‡ _____ Eye cases or burns ‡ _____
 Causes of casualties (approximate number from each cause; failure to put on mask, premature removal, etc.) _____
 Length of time masks were worn _____
 Was any part of gassed area evacuated? _____ At what time? _____
 Was attempt made to relieve units required to remain in sector? _____
 At what time (in the case of mustard gas) was disinfection of ground begun? _____
 Completed? _____
 Remarks: (should include any new tactical use of gas, any suggestions, etc.) _____
 (Signed) _____

* Shown on attached map.

† Wind velocity should be given in meters per second.

‡ Information to be given when possible.

Forwarding of Samples, Specimens, and Reports.

149. After an attack, gas-shell bases and fragments, shell-gas samples, unexploded gas shells, and notes on the attack will be handed to the company commander for transmission to the division gas officer, who will forward them to the corps gas officer. Corps gas officers are responsible for their examination, if possible, or for forwarding them to the proper place for such examination.

150. Earth samples should be taken when the use of a new gas is suspected. It must be remembered that earth samples containing shell gas are extremely perishable. For instance, moist earth gradually destroys mustard gas, and unless such samples are forwarded to the laboratory at once they are valueless.

151. Earth samples must be sealed up in a proper container. Friction-top tin cans or any tin can the cover of which can be sealed on with surgeon's tape are suitable to contain earth samples.

152. A letter of transmittal should accompany samples stating whether or not a report on the analysis is requested. If a report on the analysis is requested, the letter of transmittal should indicate whether the need of this report is urgent.

153. Chemical Warfare Service officers acting as advisors to the commanders or staffs of the units to which they are attached will be consulted and advantage taken of their technical knowledge and advice in the preparation of all plans involving the extensive use of gas, whether by artillery or by other means.

VII. OTHER MASKS.

154. Until a sufficient number of the latest type of American masks are available to supply all the American forces, certain troops may continue to make use of the following masks:

SMALL BOX RESPIRATORS.

155. This mask is similar to the American mask in general form. It differs in the following respects (see pars. 74 and 75):

The incoming air is led to the lungs through a rubber mouthpiece held between the teeth, while the nostrils are closed by a rubber clip attached to the facepiece. The eyepieces show a tendency to dim, which must be corrected by especially careful and thorough use of anti-dim composition, and by occasional cleaning of the eyepieces. (See drill below.) Spent air from the lungs also reaches the outlet valve by way of the mouthpiece.

156. The following modifications in the drill are necessary for troops equipped with box respirators:

157. *Drill "A."*—Same as for American Tissot mask.

158. *Drill "B."*—*Box respirator drill by the numbers.*

The respirator is in the "Alert" position. The helmet is worn with the strap adjusted to the back of the head. A lanyard made of shoestring or similar material is attached to the left loop of the helmet at one end and at the other is passed around the left shoulder.

Being at "Alert" position, with helmet adjusted: (1) *By the Numbers.* (2) *Gas.* Place the rifle, if unslung, between the knees. Insert the thumbs under the flap and open the satchel. Seize the facepiece with the right hand so that the metal elbow tube rests in the palm of the hand, the fingers grasping the eyepieces. *Two.* Bring the facepiece smartly out of the satchel, to the height of the chin, holding it tightly with the fingers extended outside, the thumbs inside at the binding where the tapes are attached. Pull the hands apart until the retaining tapes are taut. Thrust the chin well forward. *Three.* Bring the facepiece forward, digging the chin into it. With the same motion guide the tapes over the head, knocking off the helmet backwards. *Four.* Grasp the metal elbow tube outside the facepiece with the right hand. Insert the mouthpiece into the mouth, the teeth gripping the rubber lugs. *Five.* Grasp the nose-clip spring with the right hand. By pressure on this spring adjust the pads to the fleshy part of the nose. *Six.* Complete adjustment by running the fingers around the facepiece at the binding (to see that it is properly seated and no edges are turned in). *Seven.* Replace helmet. Resume the position of attention.

After each drill the facepiece should be cleared of gas, as in drill "G" below.

159. *Drill "C."*—Same as with latest type American mask.

160. *Drill "D."*—*Drill to teach method of testing for presence of gas.*

Take a deep breath. With the right hand pull the facepiece slightly away from the right cheek, hold the breath, *loosen the nose clip* and sniff gently. If gas is smelled, replace the nose clip and facepiece. Then clear the facepiece of gas as in drill "G" below.

161. *Drill "E."*—Same as with latest type American mask.

162. *Drill "F."*—*Inspection.*

Up to and including command (*Three*) same as for latest type American mask. *Four.* Examine the facepiece inside and out. See that mouthpiece is not split, loose, or at wrong angle, and that metal lining is in position one-sixteenth inch from opening. See that nose clip is effective and firmly attached to mask fabric. Make sure that there are no pinholes or tears in fabric, and that eyepieces are securely fastened in the facepiece. Commands *Five* and *Six* same as for latest type American mask.

ADDITIONAL DRILLS.

163. *Drill "G."*—*To clear gas from the facepiece.*

The mask being adjusted: (1) *Clear.* (2) *Facepieces.* Press the facepiece close to the face with the hands, forcing out the inclosed air at the sides. Refill the facepiece with air by blowing out around the mouthpiece, keeping the fingers on the nose clip to prevent its being displaced.

164. *Drill "H."*—*To clean eyepieces.*

The mask being adjusted: (1) *Clean.* (2) *Right eyepiece.* Grip the right eyepiece between the thumb and first finger of the left hand. Insert the first finger of the right hand into the fold of the facepiece behind the right eyepiece and clean it with a gentle, circular motion.

The left eyepiece is cleaned in a similar way, with the forefinger of the left hand, the eyepiece being held with the right hand.

VIII. SUPPLY SYSTEM.

165. Regulations for making all Chemical Warfare Service issues of supplies will be published separately.



