

E06241

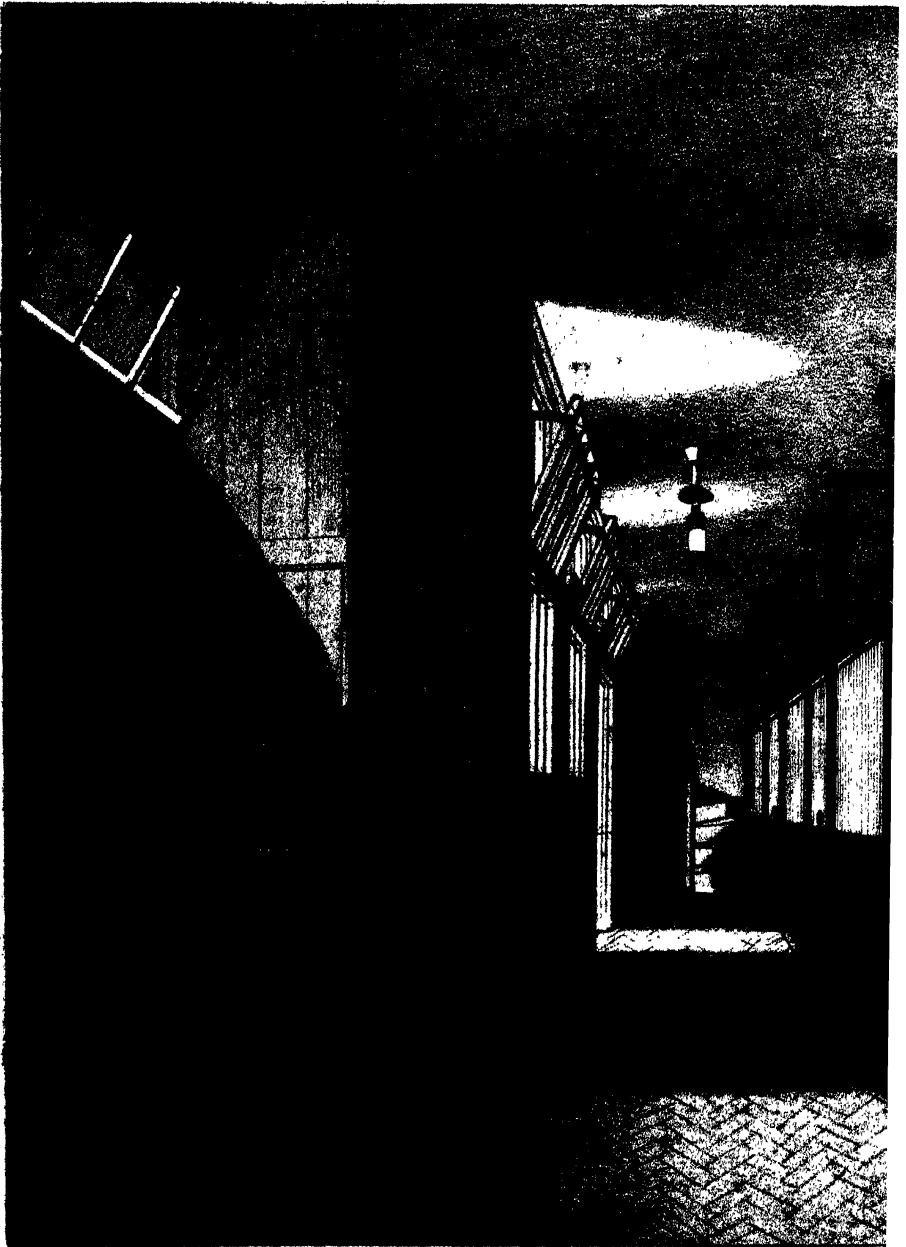

J. GENDALL DELT

INTERIOR OF THE STABLE

GENERAL REMARKS

ON

A.6.

STABLES,

AND

EXAMPLES OF STABLE FITTINGS,

With Illustrations;

BY WILLIAM MILES, ESQ.,

AUTHOR OF "THE HORSE'S FOOT, AND HOW TO KEEP IT SOUND;" "A PLAIN
TREATISE ON HORSE SHOING;" &c., &c.



LONDON:

LONGMAN, GREEN, LONGMAN, AND ROBERTS,
PATERNOSTER ROW.

MDCCLX. 1860

NAWAB SALAR JUNG BAHADUR

CONTENTS.

	PAGE
INTRODUCTION.	
Appearances too much attended to in Stables - -	2
A Stable should be purely utilitarian, and the accommodation of the horse the chief object - - -	3
GENERAL REMARKS.	
The site should be dry, sheltered, and easily drained, and not near to large trees - - - -	4
ASPECT.	
Reasons why a south aspect is objectionable - -	5
A sheltered north aspect preferred - - -	”
HEIGHT OF INTERIOR.	
Difficulty of maintaining a genial temperature and pure atmosphere in a large and lofty Stable - - -	7
Ten feet six inches high enough for the interior of any Stable - - - - -	”
Four-horse Stables with loose boxes the best arrangement for the benefit of the horses - - - -	”
DRAINAGE.	
A well-appointed Stable should be free from what is called “stable smell” - - - - -	8
Bell traps in a stable great evils, and very appropriately called “stink traps” - - - - -	”

TEMPERATURE.

The temperature of a Stable should be regulated by that
of the external atmosphere particularly in winter - 10

LOOSE BOXES.

A loose box of equal advantage to horse and owner - 12

Very little ingenuity required to contrive one or more loose
boxes in almost any Stable - - - - - ”

LOFT.

Reasons for a loft over a Stable being an advantage - 13

Sleeping apartments over a Stable a disadvantage - 14

ALTERATIONS.

Details of the conversion of a five-stalled stable and small
coach-house into a four-horse stable with loose boxes - 15

Twelve feet square large enough for any box, where horses
are permitted to see each other - - - - - 17

CONCRETE.

The best mode of preparing, and using it - - - - - 19

DRAINS.

Drains should be free from angles, and composed of un-
absorbent materials - - - - - 20

Description and arrangement of iron cess-pits and tubes
within the boxes - - - - - ”

Description of the main drain, and its junction with the
drains from the boxes - - - - - 23

Communication of the main drain with the V trap in the
stable yard, and description of the trap - - - - - 24

All the drains to be buried in concrete, to prevent the
tubes sinking, or becoming displaced - - - - - 26

A somewhat similar arrangement of drains with less ex-
pensive materials - - - - - 27

FLOOR.

Dutch clinkers the very best, and pebble pitching the very worst material, that can be used for flooring stables	28
Channels cut in the surface, to increase the drainage without increasing the inclination of the floor - - -	29
When bricks are used for flooring stables, they should be selected from the hardest burnt bricks in the kiln without regard to colour - - -	30

BOXES.

The kind of separation that should divide loose boxes from each other considered - - -	31
Details of the separation - - -	32
Entrance to the boxes - - -	35
An ingenious latch for securing the gates of the boxes -	36

MANGER.

Wood preferred to iron for mangers - - -	41
Details of mangers, water-tanks, and corn shutes - -	42

WATER SUPPLY.

Detail of the supply, waste, and overflow of the water-tanks - - -	44
--	----

RACK.

Wooden racks on a level with the horses' heads preferred to low iron ones - - -	45
Details of the racks - - -	„

VENTILATION.

Objection to the admission of air near to the ground -	47
Description of Scott's Air Regulator for the admission of air two feet from the ceiling - - -	48
Details of the mode of carrying off the impure and exhausted air - - -	49

	PAGE.
Supposed case of failure cleared up - - -	51
No plan for carrying off the impure air can succeed, unless provision be made for the admission of fresh air - „	„
LIGHT.	
Dark Stables objectionable, an ample supply of even, steady light desirable - - - -	53
Detail of windows - - - -	54
Description of a very efficient pulley for opening and closing the sashes - - - -	55
A convenient stable lantern with the mode of hanging it in the stable - - - -	56
PILLAR CHAINS.	
A simple and ingenious contrivance for securing horses by pillar chains - - - -	57
CUPBOARDS.	
Plan for converting spare corners into useful cupboards -	59
COLOURING THE WOOD-WORK.	
Staining and varnishing the wood-work of a stable preferred to painting it - - - -	60
Directions for preparing and applying an excellent staining fluid - - - -	61
HARNESS ROOM.	
How to turn every nook and corner of a small harness room to account - - - -	63
Details of harness room fittings - - - -	65
Stand for drying the pannel of a saddle upon - „	„
Block for supporting driving whips - - - -	66
Block for hanging bridles upon - - - -	67
Rod for cleaning harness upon - - - -	68

	PAGE.
Saddle bracket - - - - -	70
Rack with moveable bracket-pins and hooks - - -	„
Bracket-horse for cleaning saddles upon - - -	71
A cleverly contrived and efficient bolt for coach-house doors	75
Plan and general arrangement of the loft - - -	78
Contrivance for warming a coach-house from a fire in an adjoining apartment - - - - -	79

ILLUSTRATIONS.

Frontispiece,

Plate I. to face - - - - -	Page 16
„ II. „ - - - - -	„ 20
„ III. „ - - - - -	„ 32
„ IV. „ - - - - -	„ 36
„ V. „ - - - - -	„ 42
„ VI. „ - - - - -	„ 45
„ VII. „ - - - - -	„ 47
„ VIII. „ - - - - -	„ 53
„ IX. „ - - - - -	„ 65
„ X. „ - - - - -	„ 71
„ XI. „ - - - - -	„ 78

INTRODUCTION.

Stable building is a matter, that has hitherto received much less careful consideration in proportion to its importance, than could have been expected in these times of general improvement, especially when it is remembered, how large a number of valuable horses are annually injured, ruined, or destroyed by ill constructed, ill drained, and badly ventilated stables.

The three points, which usually engross the largest share of attention even in the better class of stables, are *first* the general appearance and uniformity of the interior, *secondly* the convenience of the groom, and *lastly* the accommodation of the horses; and unhappily the order, in which I have here set them down, is too often the order of precedence given to them, so that the poor horses literally go to the wall, where they are doomed to remain tied by the head, until it suits the convenience of some one to take them out, and enable them to stretch their legs. It is really painful to enter a well proportioned stable bearing unmistakable evidence of lavish expenditure both on its fittings and ornaments, and to observe the small space allotted to each horse, while a considerable area is permitted to remain unoccupied and almost useless behind him, which by a little contrivance might be made available for his use and comfort; but whenever I have ventured to remonstrate against this waste of space,

and endeavoured to show how it might be turned to a profitable account, I have nearly always been met by the objection, that it would look ugly, and spoil the appearance of the stable ; and the unoffending horses have been condemned to remain helpless victims of their master's undue respect for appearances.

A stable is no fitting place for the display of great taste, or unmeaning ornament ; it should be purely utilitarian in its character, nevertheless cleanliness, neatness, and order should pervade every part of it ; but where there is sufficient space, to allow of uniformity in the arrangements without in any way encroaching on the liberty of the horses, it is very desirable, that it should be indulged in ; but to see a goodly row of valuable horses strung up by their heads to the wall, with their clothing arranged on them with mathematical precision, and they themselves unable to move excepting from side to side, is but a sorry spectacle to a man, who knows what a noble, generous, and social animal the horse is by nature, rejoicing in company, and anxious to hear and see everything, that passes around and about him. I am sure it would produce a very uncomfortable feeling in me, to see my horses straining their necks, and forcing their heads round, as far as that cruel invention the rack chain would permit them, in order to ascertain whether a friend or a foe approached, instead of finding them deliberately turning about in their boxes to greet me.

Although, as I have said above, a stable offers no great field for the exercise of taste, it affords ample scope for ingenuity in adapting it to the requirements, essential to the safety,

health, comfort, and well being of the horse: I have no objection to the interests of the groom receiving full consideration; let him be furnished with every convenience, he can desire, provided it does not curtail the space, which ought to be dedicated to the use of that animal, for whose sole benefit the stable is supposed to have been built.

In planning a stable, the first consideration should be the commodious and proper lodgment of the horse, for, wherever he is placed, there he must remain, however inconvenient or uncomfortable that place may be; he has no friends to speak for him, and, unlike the groom, he is not endowed with the power of preferring his own complaints: the groom can take care of himself, but the poor horse stands in great need of some one to take care of him, and the more judicious that care is, the more cheerfully and efficiently will he perform the work, that may be required of him. It is a well ascertained fact, that a horse, whose stable is well lighted, drained, and ventilated, and in which he has room to move, will do considerably more work, and require less corn, than the same horse would do, if kept tied up in a badly contrived stable, although his allowance of corn may be greatly increased; the vitiated atmosphere he is doomed to live in, the want of pure air to breathe, and the absence of the cheerful influence of light, combine to make him dull, listless, and dispirited; and no amount of corn can counterbalance their depressing effects. It however forms no part of my present plan to dilate on how, or through "what bye paths, and indirect crook'd ways" these depressing influences work their baneful effects on the constitution of the horse, it will suffice,

that I merely direct attention to the universally admitted fact, that they do exist, and then endeavour to show, how they can be avoided ; and as practical results are always of greater value, than theoretical speculations, I may perhaps venture, without the fear of being considered too confident in my own views, to illustrate my position by recording a detailed account of some alterations I made four years ago, when I converted a five-stalled stable, and small coach-house into a stable to receive four of my own horses, and which has been declared by many good judges of stable arrangements to be very successful.

GENERAL REMARKS.

Before entering into the minute details of these alterations, I have a few general observations to offer on the choice of a site, aspect of the front, height of the interior, and other matters connected with my subject, which I think may be conveniently introduced in this place ; always bearing in mind that stable builders, like other people, must yield to circumstances, over which they have no control ; but when they are quite free to choose, they should carefully select a site, that is dry, sheltered, and easily drained ; and not very near to large trees, which not only collect damp in wet weather, and harbour flies in fine weather, but at all times impede the free circulation of air.

ASPECT.

I am inclined to think that the prevailing desire to have the front of the stable due south is a mistake, and is often attended by great inconveniences ; in the first place it is almost impossible to maintain a relative proportion in the temperature between the day and night in stables, that are so placed, particularly when hot days are succeeded by cold nights, which frequently happens in the spring of the year ; then in summer they become so insufferably hot during the day, that the doors and windows require to be left open to enable the horses to breathe, and this gives free admission to flies and other teasing insects, so that between the heat and the teasing the horses are kept in a perpetual fidget and worry from morning till night ; and in winter the circumstances are not much better, for the sun frequently shines for two or three hours in the middle of the day with an amount of heat, which makes the stable almost as hot as in summer, and this heat is often suddenly succeeded by a degree of cold approaching to freezing ; and no care on the part of the groom can maintain an even temperature within, while such extreme variations are taking place without.

My own stables face the north, but are well protected by buildings particularly on the east and west, and my experience leads me to the conclusion, that this, or perhaps a point or two to the west of the north is the best aspect, that can be given to a stable, provided it is sufficiently sheltered, and protected from the stroke of the wind ; the temperature of a stable so situated is more under control, and can be kept

lower in summer, and is subject to fewer changes in winter than a stable that has a southern aspect ; and the horses are never exposed to the direct influence of the sun's rays, which, entering the windows from the south, not only produce a perpetual shifting of the position of the light, but a constant variation in the reflections around, to the great annoyance of the horses: the light, that is admitted from the north, is more uniformly steady and less stimulating to the horses' eyes, and if flies should chance to enter the stable, they very rarely remain long there. I have frequently found on a hot summer's day, that the thermometer has been three or four degrees lower in my stable, than in any room in my house, notwithstanding the doors, windows and ventilators of the house being all open.

HEIGHT OF THE INTERIOR.

It is very generally imagined, that the interior of a stable cannot well be too high ; and we often see this notion carried to an extravagant length, in the construction of what may be called first class stables, with the view of affording a larger supply of air to the horses, and there is no doubt, that a lofty stable will contain more air, than a lower one could do ; but the question to be considered is not merely the quantity of air a stable can be made to contain, but how a sufficient quantity of pure air can be supplied to the horses, and a genial temperature be retained in the stable, when some three or four of them are suddenly taken out, and only one or two left behind. One of the greatest evils attending a lofty stable is the large amount of impure air, that accumulates in

the space above the horses' heads, which, as it becomes cooled, descends and mixes with the air below, and in this state is breathed over and over again, each time becoming less pure; and to make bad worse, I often see a range of ornamental boarding, extending the whole length of the stable, forming an arch of entrance to each stall, and carried close up to the ceiling, effectually impounding the impure air until it is sufficiently cool to descend on and about the horses. It is almost impossible to ventilate a large and lofty stable so as to supply a sufficient quantity of pure air, and carry off the impure air, without rendering the stable sometimes much too cold, and the consequence is, that such stables are rarely, if ever, ventilated at all, and the horses are confined in an impure atmosphere the greater part of their lives.

No stable should be more than 10ft. 6in. high, measured from the floor to the ceiling, and very few should exceed 10ft.; and where it is not necessary to consider either expense or space, but only to determine what is best for the horses, the most perfect arrangement would be, to divide a considerable portion of the building into compartments entirely separated from each other by brick walls, each compartment to contain four loose boxes; but it is also desirable to retain some portion of the building for a stalled stable, to meet contingencies, and provide accommodation for friends' horses. The reasons for this division into four-horse compartments are, first the difficulty that is always experienced in regulating the temperature of large stables particularly during the absence of some of the horses; next the admitted fact that horses rest better, and are quieter, when only a small number are confined

in the same stable, than when a larger number are collected together; added to which a less number are disturbed and annoyed by a restless companion, or the return of other horses from their work late at night; and lastly it is sufficiently difficult thoroughly and efficiently to ventilate an area of 40ft. long 19 wide and 10 high, and still preserve a genial temperature under every change of circumstance, for the withdrawal of two or three horses will sometimes produce a degree of cold, that ventilation cannot counteract; it can make a stable cooler, but its power to warm it is very limited.

DRAINAGE.

The importance of perfect drainage is universally acknowledged in theory, but is rarely reduced to practice, and the consequence is, that few parts of a stable are more defective, than the provisions usually made with the view of attaining this desirable object. The drains should be so constructed, as to insure the urine being carried off as quickly as possible, for, when any portion is permitted to remain on the surface, it very soon begins to give off ammoniacal and other gases, which are not only offensive, but positively injurious to the horses. A well appointed stable should be almost entirely free from that pungent smell, popularly known as "the smell of the stable;" but this desirable state of things can never be arrived at, until the use of that abomination in a stable the "bell-trap," or as it is often more appropriately designated the "stink-trap," is discontinued; so common however is its

use, that scarcely a stable, laying claim to the smallest pretension, can be found without at least one of these traps placed in each stall with the avowed object of preventing a draft, or a smell coming from the drain; but before it can do either, it must contain a sufficient quantity of urine to cover the sides of the inverted bell all around, otherwise it would fail to act as a trap at all; so that, in order to avoid an occasional draft, or smell from the drain, a series of these evaporating pans filled with urine are constantly exposed in various parts of the stable, as if the object had really been to furnish a regular and unceasing supply of noxious gases for the use of the horses; but as the draft can be entirely prevented by a simple trap in the drain outside the stable, and the drain itself be so constructed, that no urine can possibly lodge in it, I think, that the employment of these ingenious, but most injurious bell traps may be discontinued with great advantage. In some situations they are invaluable, but in a stable they are sadly out of place.

TEMPERATURE.

The temperature of a stable should be entirely governed by the temperature of the external air. In summer, when the heat is often too great every where, the object should be to keep the stable as cool as possible, always taking care to avoid drafts; there is little fear of finding a stable, full of horses, too cold at any period of the year, they are on the contrary usually much too hot; and a sort of undefined

notion prevails, that 60 degrees is about the average heat, that stables should possess, but grooms for the most part like to add a margin of some seven or eight degrees to it, and the colder the weather, the hotter they endeavour to keep their stables, which is very unphilosophical to say the least of it. Let us for a moment imagine the thermometer out of doors standing at 32, and in the stable at 60, and then contemplate the condition of the poor horse, stripped to the skin, and suddenly exposed to an atmosphere 28 degrees colder than that, in which he had been confined for perhaps 20 or 22 hours, loaded with warm clothing; but the mere exposure of his body to the cold is by no means the worst of it, no doubt it is a severe shock at the time, but exercise will produce a re-action, and he will soon become warm again; the great trial to his constitution is the effect the transition may have on the membrane lining the air passages of his lungs, which, having been accustomed for so many hours to a temperature of 60 degrees, becomes irritated and disturbed by the sudden withdrawal of 28 degrees of heat from the air, which passes over its surface, every time he breathes. The evil is traceable to an unreasonable desire to see the horse with a summer coat on in winter, and to effect this object every expedient is had recourse to, that holds out a prospect of keeping the stable as nearly as possible at summer heat; but surely this is a grievous mistake, for the horse's constitution is of far greater value to its master, than its skin can be; whatever their relative value may be in the estimation of the groom.

In cold weather a stable should always impart a feeling

of warmth to a person on entering it from without, but it should never be really hot; and I may here caution those gentlemen, who are in the habit of judging of the degree of heat by their own feelings alone without the aid of a thermometer, that they are in great danger of being misled as to the actual condition of the temperature, for the more intense the cold is outside the stable, the greater chance there is of their feelings deceiving them, and inducing them to mistake only a proper amount of warmth for too much heat; it happened to myself in December last to visit my stable, when the temperature outside was below 30°, and my first impression was, that it was much too hot, but on referring to a thermometer hanging against the wall I discovered, that my feelings had deceived me, for it stood no higher than 44, which certainly was not too hot, nevertheless it was quite hot enough, as compared with the cold outside, for it continued to feel warm and comfortable during the whole of my stay there.

The best rule for the treatment of horses in the stable in very cold weather is, to keep their bodies warm by clothing, and let them have plenty of cool, pure air to breathe; it is undesirable, that the air should be cold, but it is of great importance that it should not be hot.

LOOSE BOXES.

It would be quite impossible to over estimate the value of loose boxes as compared with stalls for the lodgement of horses, and if horse-masters could be induced to think seriously

whenever close, or damp weather may make such a proceeding desirable ; and I am moreover of opinion, that the noise, caused by persons moving about over the horses' heads, is not without its advantage, as it accustoms them to sounds, which they cannot account for, but which do them no harm, and they soon cease to heed them altogether, and become less alarmed at unusual noises, when they are out ; I consider this such an important element in training my horses, that I have the chaff cutter, corn bruiser, and bean crusher all worked in the loft over the stable, with a view of familiarizing them to various sounds during the day, but I would on no account permit them to be disturbed at night, and therefore I should decidedly object to sleeping apartments being placed over the stable. When stable servants are required to sleep on the premises, they should be over a coach house at a convenient distance from the stable, but still not so far removed, as to prevent their hearing any unusual stir among the horses during the night.

ALTERATIONS.

With these general remarks I will proceed to describe the alterations before alluded to, which, I am bound to confess, have fully answered all the particulars, for which they were undertaken ; and in this I am not recording my own opinion alone, but that of a large number of practical and competent judges, who have been pleased to express themselves in terms of commendation, which it would ill become me as the designer to print ; I may however be permitted to mention,

as a fact apparent to any one, who enters the stable, that there is ample space for the horses, no lack of accommodation for the groom, scarcely any smell to be perceived, a good supply of fresh air without draft, and an abundance of light without sun, which I hold to be essential requisites in a well ordered stable: and if it should appear to any of my readers, that I have entered with unnecessary minuteness into details in what follows, my answer must be, that I have done so from a desire to remove some of the difficulties, which usually present themselves in adapting an old building to new arrangements, and if possible to save those, who are disposed to attempt such a change, from a portion of the thought, trouble, and difficulty that attended my own alterations; and I am not without hope, that some useful and practical hints may be gleaned from them, which may arouse others to a sense of the unnecessarily cruel imprisonment, they inflict on their horses by the usual mode of stabling them, and which is surely an ungrateful return for the willing service, the poor brutes are at all times ready to render either for the profit, or the pleasure of their masters.

The stable, I had to deal with, was like many others made to contain as many horses in a row, as could be crammed into it with any prospect of their being able to lie down. It was 30 feet long by 16 feet 6 inches wide, and contained five stalls, each stall was 5 feet 8 inches wide by 6 feet 3 inches deep, measured from the front of the manger, which occupied 10 inches, to the heel post; this left a space of 9 feet 5 inches from the heel post to the front wall, see fig. 1, plate I, which space was useless, excepting in so far as

it gave the horses ingress and egress to their stalls, and contained a gutter, that extended from end to end of the stable, affording very questionable drainage; so that the distribution of space amounted to this, 459 square feet were divided between five horses, giving $35\frac{1}{2}$ square feet for the accommodation of each horse, while $282\frac{1}{2}$ square feet were appropriated to the gutter and gangway; which by no means accorded with my notions of a just apportionment of the space.

I had bestowed much time and thought on the alterations I had proposed to make, and drawn my plans, and settled the proportions and details of every part, when a question arose as to the safety of removing the wall of separation between the stable and coach house; and on this point I consulted my friend Mr. Hayward, a talented architect residing in Exeter, to whom I am indebted for many valuable and practical suggestions as to the best mode of carrying out my views, and who soon shewed me, that it was one thing to know what I wished to do, and quite another thing to know the best way of accomplishing it; but I am more especially indebted to him for his kind and liberal offer to aid my present undertaking, by supplying the accurate and carefully executed drawings and plans, without which I fear, my descriptions would be found very imperfect, and difficult to understand. The removal of the wall between the stable and coach house gave me an area of $39\frac{1}{2}$ feet by $16\frac{1}{2}$ feet. I should have liked some two or three feet more of width, if I could have had it, but as that was impossible, I was obliged to make the best of the space I could get,

GROUND PLAN PREVIOUS TO THE ALTERATION.

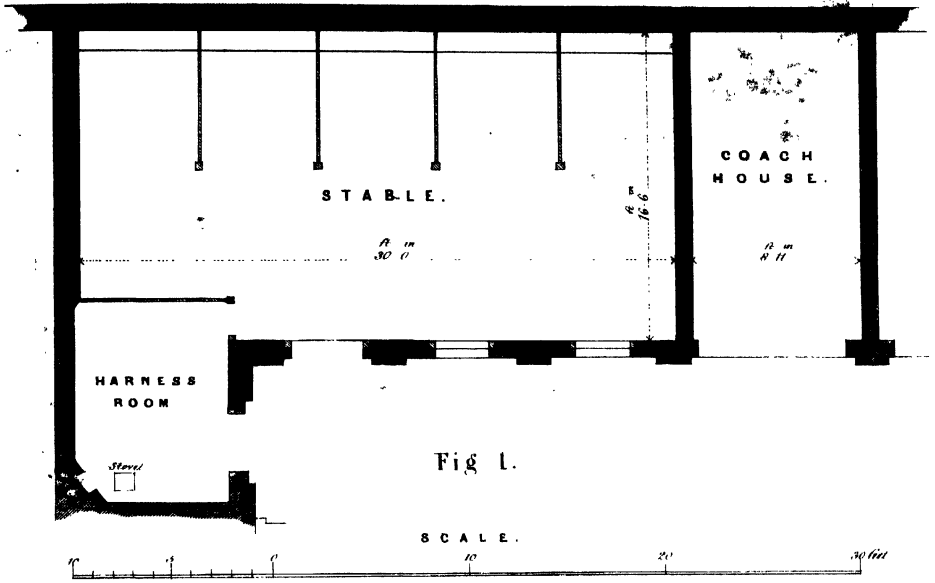

PRESENT GROUND PLAN.

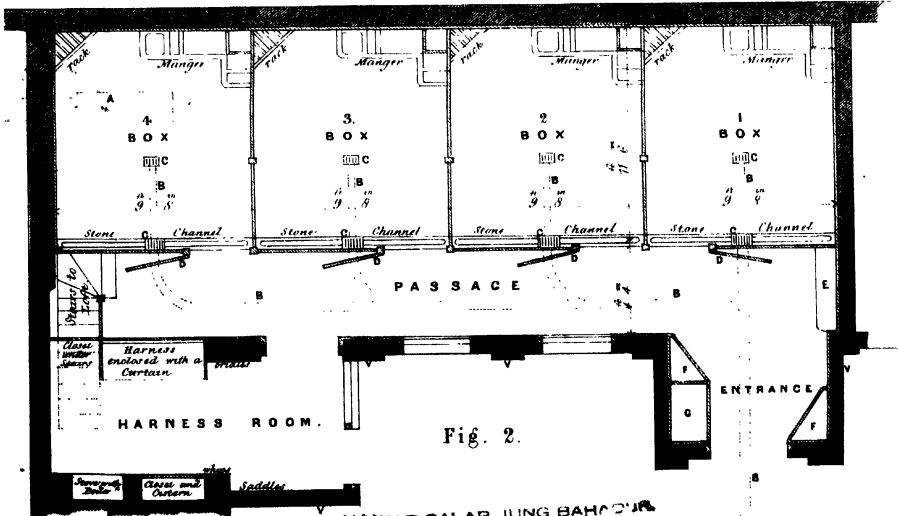

NAWAB SALAR JUNG BAHADUR

- A. Opening in Ceiling for light, there being no window at this end of the Stable
- B. Drains.
- C. Gratings, see detail Plate.
- D. Doors of Boxes, intended to be wholly thrown back, but shown only partially so
- E. Seat with space underneath for buckets.
- F. Closets for Forks, Brooms, &c.
- G. Enclosed space for raising provender to the loft by a Crane or Pulley
- V. Vachlatane



and my first care was to ascertain, how I could apportion it, so as to give the largest possible amount to the horses, and retain the smallest convenient amount for a passage to their boxes; and after a series of measurements of various stable doors and gangways I determined, that four feet four inches gave ample room for a horse with his harness on to pass freely through, provided there were no projections, that he could by any accident hitch in; and the experience of four years has fully confirmed my conclusion, for I have never yet met with a single mishap; nevertheless I should always prefer a wider passage, when it can be obtained without contracting the boxes.

It has been said, that few things would be easier, than to plan a house even in a limited space, if it were not for the stair-case; and I may add, that it would be equally easy to plan loose boxes, if it were not for the necessity of providing an access to them. But having at length settled the width of the passage, the remaining space was easily disposed of. I found, after allowing for partitions and lining, that I could make four loose boxes, each measuring 11 feet 6 inches by 9 feet 8 inches in the clear, Plate I, fig. 2, which is very nearly as large, as I should ever desire to have them in my own stable. I think that 12 feet by 10 feet for moderate sized horses, and 12 feet square for horses sixteen hands high is quite as large, as any box ought to be in a stable, where horses are permitted to see each other, for, when the boxes exceed these dimensions, the horses are very apt to jump and play in them, and may chance to slip up and injure themselves; they should have perfect freedom of

DRAINS.

It has often occurred to me, that the peculiar smell which hangs about the clothes of every person, who pays a lengthened visit to a stable, was not an inevitable consequence of horses being confined therein, but rather the result of some radical defect in the mode of draining the stable; I therefore determined to try, whether I could not by a well considered system of drains avoid this evil in the stable, I was about to remodel; but whether I succeeded or failed, I was certain I should improve its general atmosphere, and the result of my effort has been very satisfactory, for almost every one, who enters the stable, remarks on the purity of the atmosphere, and the absence of "stable smell."

The drains are composed of materials, that are entirely unabsorbent, and are so arranged, as to be free from any angles, corners, or projections which could cause a lodgement, or impede a free passage through them; those within the boxes are made of iron, and the main drain, which passes under the floor of the passage, is formed of six-inch stoneware, glazed tubes, jointed and socketed in cement. The drains in the boxes are all alike, and as the drain of the stable really begins in the box, the furthest removed from the stable door, that will be a convenient point from which to commence their description. A cast-iron cess pit is sunk in the centre of the floor, Plate II., A, where a bell trap is usually placed, and is embedded in concrete with its upper edge about half an inch below the level of the floor of the box; it is cast with a frame surrounding the upper part, to receive a stout

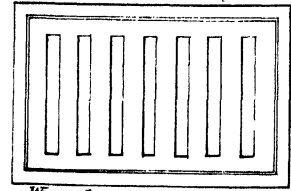

Wrought iron grating over Cesspit B.

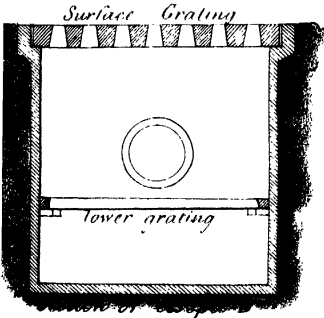

Surface Grating

lower grating

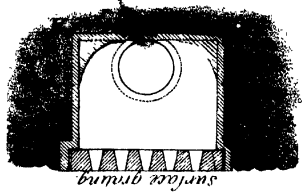

surface grating

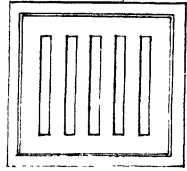

Grating over Cesspit A

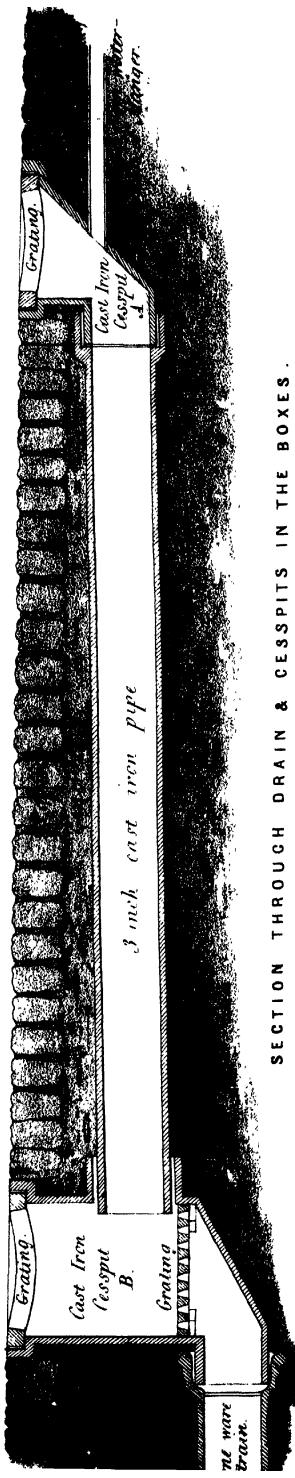

SECTION THROUGH DRAIN & CESSPITS IN THE BOXES.

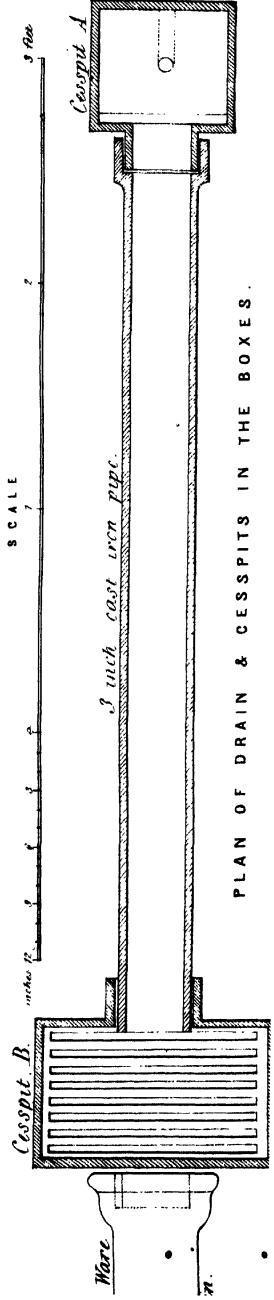

PLAN OF DRAIN & CESSPITS IN THE BOXES.

wrought-iron grating, 8 inches long, and 7 inches broad; cast-iron is too brittle to be used for the grating, it could not withstand the stamping of the horse, and would be soon broken. The form of the iron pit resembles a short, thick wedge, cut through the side lengthwise, that is, the front is perpendicular to the floor, and the back sloping, so as to meet it at an acute angle in the bottom of the pit, which at this point is five inches deep: the corners formed by the junction of the front, back, and sides are filled up in the casting, and are slightly concave towards the inside; and to provide against the possibility of a lodgement in those parts, they meet the sides of a circular opening in the front, which is three inches in diameter, and is cast with a flange rim projecting from the front of the pit towards the front of the box, to be attached to an iron tube of the like diameter; this opening commences at the very bottom of the pit, so as to offer no impediment to a quick and free passage through it. There is also a hole in one of the sides of the pit, to receive the end of the waste pipe of the water trough, through which the drain can be flushed at pleasure; but the explanation of this had better be reserved, until I treat of the water supply.

The iron tube, which is attached to the centre pit communicates with a second cast iron pit, plate 2. B, which is also embedded in concrete, and is placed in the stone gutter immediately within the box but in a direct line from the centre pit: this second pit is larger, than the centre pit, and differs somewhat from it in form, Plate II., B, to enable it to perform two widely differing offices,

viz. to detain any portion of straw, or other solid matter, which may pass into it either from the centre pit, or the box, and at the same time maintain a free passage for fluid into the main drain; to accomplish these objects, although the pit is cast in one casting, a provision is made for separating it into two compartments by having the lower portion thicker than the upper, so as to form a ledge all round, to support a moveable grating which rests upon it. The upper opening also has a frame cast in its rim, to receive a grating, and measures 14 inches by 9 inches, and the front, back, and sides are carried down perpendicular to the floor of the box to a depth of ten inches, where they meet the ledge; from this point the pit assumes the shape of the centre pit in every particular, that is, the front descends in a straight line, the back slopes forward to meet it, and the corners are solid; there is however no hole in the side, and the opening in the front is six inches in diameter with a flange rim on the outside, to unite with the first of the stone-ware tubes of the main drain: the depth of the lower compartment is eight inches, making the whole depth of the pit eighteen inches.

There is an opening in the back of the upper compartment, large enough to admit the end of the tube that conveys the drainage from the centre pit, which, on falling, becomes separated by the grating into solid and fluid parts; the solid parts are detained, and can be removed from above, and the fluid passes through the lower compartment into the main drain. The grating, that covers the mouth of the pit, is made of stout wrought-iron, and the bars run in a trans-

verse direction ; but the lower grating, which is not exposed to injury, is made of cast-iron, and the bars are smaller, and placed closer together, and run in a longitudinal direction with a view of preventing anything, that may fall through the upper grating, from passing into the lower compartment. The pits, being fixed in concrete, and the frames cast as a part of them, afford a steady and lasting support to the gratings, which fit into the frames very accurately, and are readily removed and replaced by the aid of a simple instrument made of iron about a foot long with a round cross piece at one end for the hand, and a shorter flat cross piece at the other, to be inserted between the bars of the grating, which by a turn of the hand catches a bar on each side, and gives a good purchase for lifting it straight out of the frame, and by the same means it can be readily dropped into its place again.

The junction of the drain of the box with the main drain of the stable is effected by a curved six-inch stone-ware tube, one end of which is attached by the socket to the flange rim projecting from the opening of the pit, and the other end is inserted into the socket of the first of a series of tubes, which form a continuous drain under the floor of the passage, Plate I. fig. 2, B ; but when it arrives at a convenient place in front of each of the two next boxes, the straight tube is changed for one divided for about one third of its length into two branches, like the fork of a tree, each branch however being six inches in diameter ; one carries on the straight line of the drain, and the other diverging from it, inclines backward to meet a curved

tube, issuing from the drain of the box, and is united to it by a socket and joint, so that the drainage from each box passes into the straight run of the main drain by an easy curve without any impediment. It was necessary to make a turn in the drain, opposite the box which faces the door of the stable, and this was effected by jointing one end of a curved tube into the straight tube of the main drain, and the other end into one of the branches of a forked tube, and then forming a communication with the drain from the box by a straight tube, jointed into the other branch; by this arrangement all chance of an obstruction is avoided, for where the branches of the forked tubes separate, the diameter of the tube is doubled, and the inner surface of the tubes being glazed greatly facilitates the passage of the contents of the drain; from this point the drain is continued in a straight line out of the stable into the yard, where it opens into the upper part of a pit, which is square at the top, and gradually diminishes from front to back as it deepens, resembling the letter V, and is lined with brick, and cemented all round. This pit is divided by a thick slate through the centre from above downward, extending to within eight or nine inches of the bottom of the pit, and is covered by a thick stone, roughed on the surface, with an iron ring in the centre for the convenience of lifting it occasionally, to examine the pit; the stone drops into an oak frame, resting on brick work.

The drains from both my stables discharge themselves into the upper part of the pit on the side, nearest the stables, and the rain pipes and surface drains of the yard

are discharged into it on the other side of the slate, there being an outlet on that side, placed lower down in the pit, than any of the inlets of either side, but still high enough to ensure the detention of a body of water, sufficiently deep at all times, to keep the lower end of the slate immersed; this forms a very efficient trap, preventing the return of either draft or smell to the stable through the drain; it is also useful, where the stable is infested by rats, for they almost always come up through the drains, and this pit may be made to form a complete barrier to their further progress, by having a flat stone or slate placed under the last of the stone-ware tubes, projecting into the pit some three or four inches beyond the opening of the tube; and if a rat should happen to dive under the slate tongue, he will be unable to mount over the flat projection, and his attempt to obtain access to the stable will be defeated. My reason for placing the opening of the stable drains on one side of the slate, and those of the rain and surface drains on the other was, to provide against the draft, occasioned by a high wind, entering the gratings and rushing through the drains into the stable, which must occasionally have happened, if all the drains had opened into the pit on the stable side only of the slate.

The depth of the V trap, as this pit is usually called, must depend on the amount of fall, that can be obtained for the stable drain, and the means there may be of disposing of the overflow, after it leaves the pit: there is no advantage in having the pit deeper, than is absolutely necessary, because the more rapidly its contents are changed

and passed off by the overflow pipe, the better, and the larger the quantity of water that is passed through it, the freer it will be from sediment. The drains, which carry the rain and surface water, materially aid in keeping it clear and clean; but it will be seen further on, that I have provided additional means, whereby I can flush the stable drains and the pit, whenever I please. The tubes, which form the stable drain, require to be lain down with great care, for the least irregularity in the fitting of one tube into the socket of the other, where they join, will interfere with the run of the drain and impair its efficiency. A trench should be dug deeper and wider, than the tubes it is to contain, so as to leave ample space beneath and on each side for a good bed of concrete, with which the bottom and sides of the trench should be lined, after it has been carefully adjusted to the intended fall of the drain. It is generally considered, that an inch on every six feet of drain is sufficient, but I very much prefer two inches, when the circumstances of the ground and the outlet of the trap will admit of it. Water should be occasionally passed through the tubes during the process of laying them, to ascertain the rate at which it flows, and it is always worth while to have some one present, who is really interested in the success of the work, to see that it is not slighted, nor carelessly done; for when the tubes are once buried, there is an end to any alteration, however defective the flow may be. None of the earth should ever be returned to the trench, but the whole of the cavity should be filled in and brought to

a level with the surface by concrete; which will prevent any future sinking or displacement of the tubes.

A somewhat similar arrangement of drains may be made, that would be very efficient, at a considerably less cost, although perhaps not so entirely free from smell, by using thick slates for the pits, and three and a half inch common draining tubes for the communication between them, and six inch common draining tubes for the main drain; they would however require to be lain with great care, and should be completely imbedded in concrete: the pits also should be first formed in concrete, and then lined by portions of thick slate, cut to the proper shape, and set in cement. The tubes, which connect one pit with the other, should have a round stick of the same diameter as the tubes passed into them, after they are lain and before they are buried in concrete, and it should be permitted to remain there for a day or two, until the concrete has become hard; this will prevent their sinking, and preserve a regular and even fall from one pit to the other, and when the stick is removed, the second pit can be formed, and the remainder of the drain proceeded with. Both the pits can be made exactly like the iron ones above described, and the ledge, to support the under grating of the larger pit, may be contrived either by employing slate of double thickness for the lower compartment, or by placing a thick lining of slate within the outer one. The upper gratings should be of wrought iron, and have a well secured frame to drop into.

FLOOR.

A great variety of materials have been employed at different times for the purpose of flooring stables, but I believe, that none of them combine so many advantages with so few defects, as Dutch clinkers; they possess all the hardness and solidity of stone without its slippery, or cold surface, they are more durable, and less absorbent than either brick or wood, and consequently freer from smell, and more easily kept clean; their small size and rough surface enable the horse to obtain a secure foot hold, and if they are set in Portland cement on a deep bed of concrete, they form the best stable floor, that has ever been suggested, and on which a horse will move about with perfect confidence. The very worst material, that can be used, is unhappily that, which is the most frequently met with, I mean pebble pitching; its unequal surface renders it inconvenient for a horse either to stand, or lie down upon; the interval, which necessarily occurs between the pebbles, enables the earth to absorb any amount of moisture; it soon falls into pits, is easily displaced, and in fact possesses all the disadvantages of all the other materials without one of their good qualities. I have no experience of India-rubber, which I understand has been used for the purpose in some few stables; but if I were to theorize about it, I should say, that the elasticity, for which I have heard it chiefly commended, is a very objectionable quality in a stable floor.

My own stables are paved throughout with Dutch clinkers, set in Portland cement on a bed of concrete, and are lain

in what is called the herring bone pattern, which is the best mode of arranging them for wear; and it improves the foot hold for the horse by causing him to bear on portions of three or four clinkers at a time with each foot, whether he is standing still, or moving about. The floor of each box across its whole breadth has a gradual inclination from back to front of an inch and a half, and is cut into channels, which converge towards the pits, and are sufficiently wide at the upper part to prevent the heels of the shoes becoming fixed in them; they are cut shallow at the end, which is furthest removed from the pits, and deepened as they approach them, whereby, the fall is increased, and the level of the floor retained. All the channels on the upper or manger half of the box empt into the centre pit, and those of the lower half into the lower pit, or into the stone gutter within the front of the box, which gutter is shallow at each end, and deepens towards the pit; by this arrangement all the moisture is readily and quickly carried off, and the surface is kept dry. It is not a very easy matter to get these channels cut, so as to insure their even and gradual deepening, for the clinkers are so hard, that the tools commonly used by stone masons will scarcely touch them with any certainty of effect, and I found it necessary to employ granite masons for this portion of the work, their tools being better suited for the purpose.

The expense of Dutch clinkers may sometimes prove an insuperable objection to their use, in which case common bricks placed on edge in a herring bone pattern may be substituted; they form a better and less slippery floor, than

flat tiles, and are less liable to be broken, but they should be carefully selected without reference to their color from the hardest burnt, and least porous bricks in the kiln; if this precaution is not insisted on, and the choice should be entirely left to the bricklayer, he will select those only, which present the brightest and most even red color; such as will make the best appearance, when they are lain down, not caring whether they are capable of absorbing a pint or a quart of moisture each, so that they look well, when he hands over the work to his employer; but it makes a vast difference to his employer, whether the bricks are merely good looking and absorbent, or ill looking and hard: there is no objection to the passage, which is exposed to view, being floored with bright and smart looking bricks, but all the others should be well burnt and hard, even though they may be of a bad color and unsightly.

The whole floor of the stable should be supported by a thick bed of concrete, and set in Portland cement; but in districts where lime and gravel to make concrete are both scarce, a deep and solid foundation may be made of stones broken into various sized pieces, and rammed down into a mass. The floor, whatever material it may be made of, should never be lain on the bare earth, however carefully the earth may have been previously prepared by ramming, for moisture will always find its way either through the material itself, or between the interstices, and cause the floor to sink into pits, which will collect the urine, and keep up a constant evaporation to the great detriment of the atmosphere of the stable. The small additional cost of

placing a firm foundation under the floor is a very good investment even in an economical point of view.

BOXES.

There are several circumstances to be considered in determining the kind of separation, that shall divide the boxes from each other, and from the passage in front of them. The horse is a gregarious and social animal, and is not satisfied with the bare knowledge, that he has a neighbour near at hand, but he likes to see him, and enjoy his company, provided he does not chance to be of too lively a turn, and indulge in the amusement of teasing him, when he wishes to be quiet, in which case he finds it very convenient to have a secluded spot to retire to out of his way; so also when he is feeding, it is important that he should not be hurried, or molested by a neighbour on the other side of the partition, evincing an unmistakable disposition to help him, if he possibly can; for which reason they should be made to feed as far apart, as the size of the box will permit, by placing the mangers and racks in such a relative position to each other, that no two of either kind shall abut on the same partition; this arrangement will cause all the horses to turn their heads in the same direction, and consequently away from each other while they are feeding, and they will be enabled to feed in peace, undisturbed by the hope of gaining some of their neighbour's share, or the fear of losing any portion of their own.

The plan I have adopted has met these conditions very successfully, and I find my horses harmless to each other, and neither dangerous, nor troublesome to visitors.

PARTITIONS.

The partitions, which separate the boxes from each other and from the passage in front, are composed partly of wood and partly of iron rails, Plate III. Those between the boxes are seven feet high ; and are strengthened by being let into two oak posts, one placed seven feet from the upper end of the box, and the other at the end of the partition, where it meets the passage. These posts are five inches square, charred and pitched at the bottom, and let eighteen inches into the ground, where they rest on a rough block of stone previously sunk for their support. The upper end of each post is framed into one of the beams of the loft floor, and the corners are chamfered for the protection of the horses : the top, which rises above the rail, is turned in the form of a baluster, to avoid the heavy appearance of so many square posts extending to the ceiling, and I beg to say, that this is the only approach of ornamentation, that I have admitted into my stable ; my object throughout has been to keep it purely utilitarian in every part. I find that seven feet is quite high enough to prevent horses under 16 hands high biting each other over the top rail, which extends in a straight line from end to end of the partition, Plate III, fig. 1.

The wooden portion of the partition consists of two

Fig. 1.

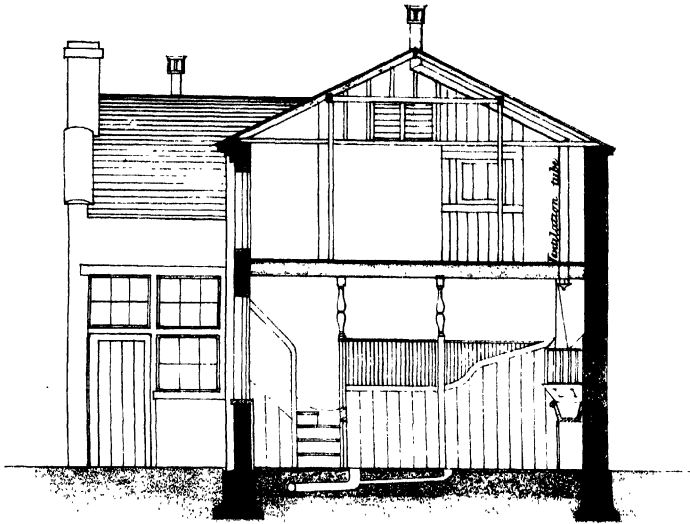

TRANSVERSE SECTION OF STABLE.

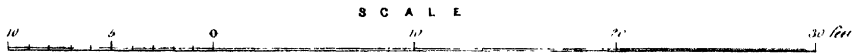
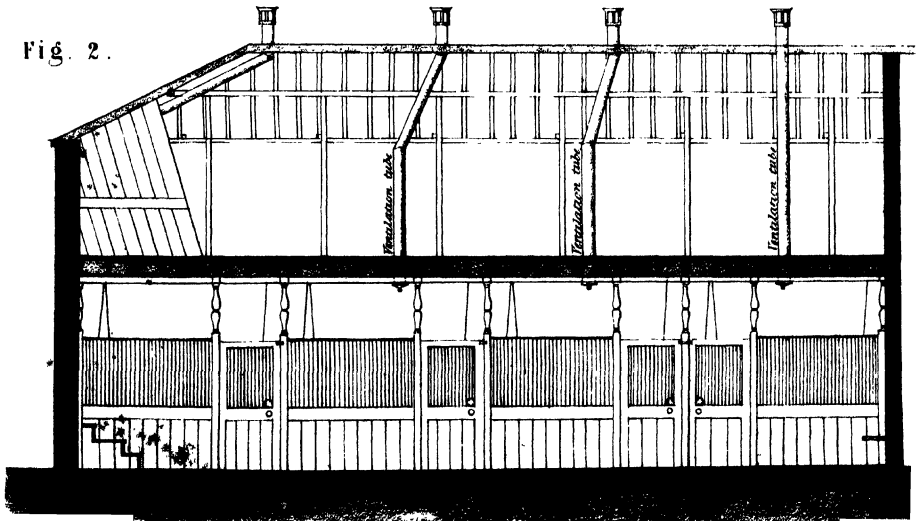

Fig. 2.



LONGITUDINAL SECTION OF STABLE.
SHOWING THE FRONT OF THE BOXES

thicknesses of inch and a quarter deal, one side placed longitudinally, and the other upright; both being ploughed and tongued, and let into the posts, which are grooved to receive them; they are firmly nailed together from each side, and surmounted by an oak capping four inches wide on the top by two and a half deep, into which they are also grooved, and the capping is morticed into the posts, and secured by a tenon and pin. This arrangement renders the partition much stronger, than it would be, if the boards were single and of one solid piece, for the fibres of the wood of one side, running in a different direction to those of the other contribute to their mutual support, and may defy the efforts of the most inveterate kicker to split the partition. I draw my experience from the worst kicker in the stable, I ever saw, who could do no more, than indent the impression of his shoes in the face of the board on his own side; he tried very hard for three years; he bent the iron bars into various shapes, and inflicted divers injuries on every part of his box, but he never succeeded in splitting the double boarding.

The wood work of the partitions should not be permitted to rest on the floor, neither should it be removed too far from it, for in the first case it is apt to rot, and in the second the horse may chance to get a foot entangled, when he is rolling; half an inch is sufficient to allow the air to pass under the wood and keep it dry. At the upper end of the box the partition is entirely formed of wood, and rises to the height of seven feet, it then inclines gradually downwards at the rate of two inches to a foot, until it has

reached five feet, when it begins to fall by an easy ramp for two feet more to the first post, at which point the top of the capping is four feet six inches from the floor; and this height is continued in a straight line to the post at the end of the partition, which is completed to the height of seven feet by five-eighth round iron bars placed one inch apart, and riveted top and bottom into flat iron rails one inch and a half broad by half an inch thick; the bottom rail follows the form of the oak capping, and is firmly screwed to it at short intervals throughout its whole length, Plate III., fig. 1: the top rail is screwed into the highest part of the capping, and is continued in a straight line to the end of the partition, being let into the posts, where it meets them, which greatly increases its firmness. It will be seen from this description, that the iron work from the post at the lower end to the next post is two feet six inches high, and from that point to the upper end of the partition gradually diminishes for a few bars, and then suddenly becomes much less, until it dies away into the thickness of the top and bottom rail only.

This kind of partition offers as little obstruction to the free passage of the air, as is consistent with keeping the horses safe from each other, at the same time that it furnishes them with a secluded nook of six feet by nine feet to retire to for quiet, and to feed in.

In the front of the boxes Plate III., fig. 2, where the same necessity does not exist for a high partition and close bars, the height is diminished to six feet seven inches, and is equally divided between the boarding and the bars, each

occupying three feet three inches and a half. The boarding of each box is placed upright towards the passage, and lengthwise within the boxes, and is surmounted by a rail nine inches deep and two inches and a half thick, morticed into the posts, and secured by a tenon and pin at each end; the under part is grooved to receive the boards, and the upper edges are chamfered to the width of the iron rail, which rests on, and is screwed to it. The bars are fixed one inch and three-quarters apart, which is sufficiently close to prevent the horses incommoding a passer by, and wide enough to admit the air freely without diminishing the strength of the railing. The bars are riveted into the top and bottom rails, and the top rail is let into both posts. I generally find my horses, very soon after they have fed, standing quite at their ease with their heads down and turned from the manger towards the front of the box, evidently enjoying the luxury of free breathing, and little disposed to disturb either themselves, or their neighbours.

The entrance to each box is thirty-seven inches in the clear, and although my coachman tells me, that he has never experienced the slightest inconvenience in passing horses over sixteen hands high in, or out, I nevertheless think, that an inch or two more of width would be an advantage. The gates are placed at the corner of the box, which is nearest to the stable door, and are hung to posts similar to those at the end of the partitions, against which they shut; they are made to open outwards, and when completely open, to rest against the front of the box, so that each horse passes into his box between two strong oak posts clear of the

Fig. 1.

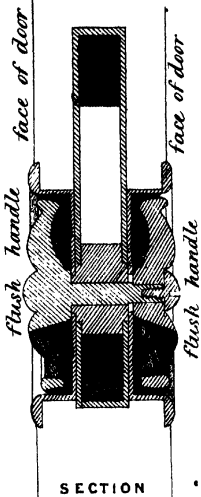

Fig. 2.

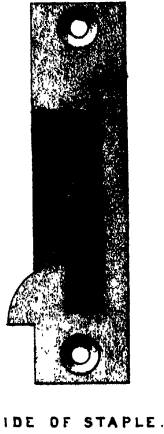
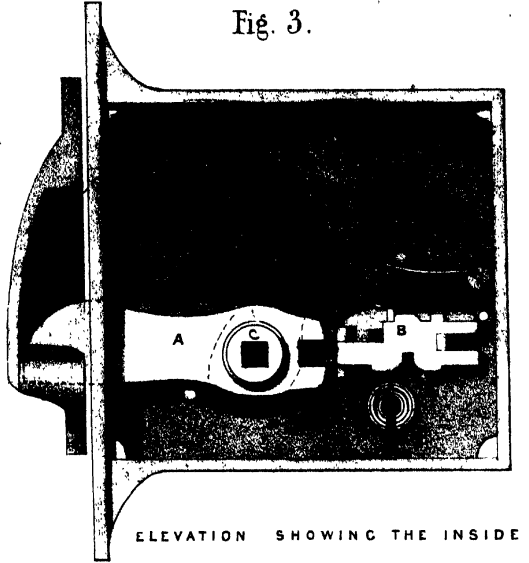

Fig. 3.



STAPLE LATCH & LOCK ONE HALF THE REAL SIZE.

- A The bolt or latch which when lifted and thrown back is entirely within the case as shown by the dotted lines.
- B The bolt of a small lock, which shutting into that of the latch, secures it.

Fig. 4.

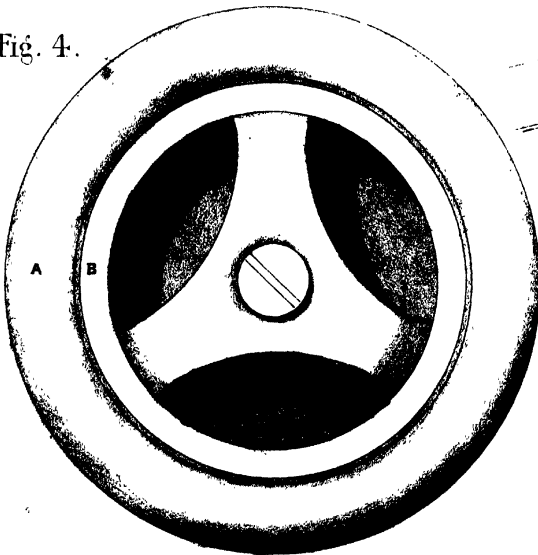
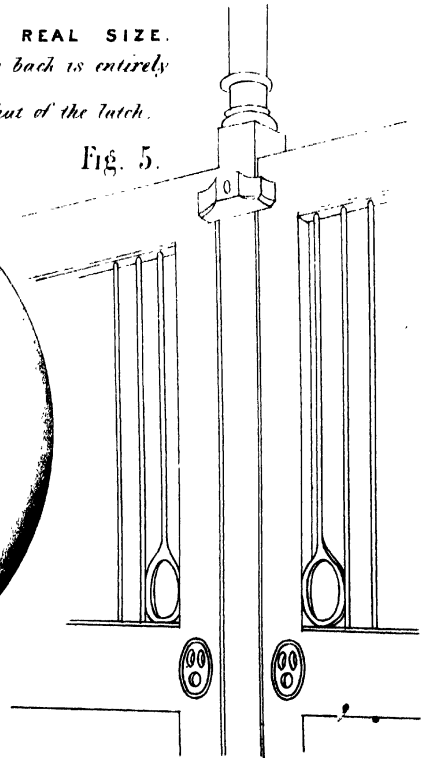

Fig. 5.



FASTENINGS FOR DOORS OF BOXES.

gun metal, which do not rust, I should say, it would be quite perfect. It is unincumbered by any spring, and requires the use of one hand only, or indeed of one finger to raise it; and when it is desired, that the door should remain unfastened, a slight turn of the hand will throw the bolt back into the case, where it will rest, until it is put forward again; which is often very convenient, particularly when horses have to pass in or out of the stable, or boxes. Fig. 3, Plate IV., represents the latch in combination with the lock, and the dotted lines show the situation of the bolt, when it is thrown back. The lock, which requires only a small key, that may be carried in the waistcoat pocket, is better adapted for stable doors, which open inwards, than for those which open outwards, in consequence of the bolt in the latter case being somewhat exposed; the latch however answers equally well for boxes, whichever way the gates may chance to open. The stable door should have a sunk ring let in to the outer side above the lock, to be used in rough weather, when the wind opposes the opening, or closing of the door.

It will be seen by referring to the plate, that shortening the case, and omitting the works of the lock will at once reduce it to a latch only, in which state I have principally used it, having already very good locks with a master key on my stable and coach house doors; otherwise I should certainly have adopted it in its double capacity of lock and latch. Fig. 4 represents the circular socket and wheel-handle, A marks the flanged rim of the circular socket, in which the wheel B works, for turning the spindle and lifting the bolt

out of the catch ; this socket is let into the wood work until the flange comes flush with the face of the door, and is then secured to the case of the latch by two screws, which keep it steady and prevent it shifting, when the spindle is turned : a brass "bush" with a square hole in the centre, corresponding to the hole in the bolt marked C, Fig. 3, is let into each side of the case for the spindle to work in, and the wheel-handle is secured to the spindle by a plain head on one side, and a screw on the other. When the lock or latch is attached to an outer door, there should be two wheel-handles, one on each side, and the screw should be placed on the inside, to prevent its being removed as a matter of mischief, but when it is used as a latch for boxes, the inner wheel should be omitted, and the screw placed on the outside in the centre of the wheel, as shown in fig 4, to guard against the ingenuity of an active minded horse. As a further security to the gates of the boxes, when the horses are left alone either by day, or at night, I have a wooden button attached to the post, against which each gate closes, opposite to the top rail of the gate. Boxes one and two shut against the same post, so that one button secures them both. Fig. 5, Plate IV., shews the position of the latches, the hand hole in the iron bars, and the wooden button of these two boxes.

The back wall of each box is boarded to the height of seven feet with inch boarding, placed upright, surmounted by an oak capping and nailed to inch deal battens three inches wide, and two feet apart, securely fixed to the wall by wall hooks ; the battens and back of the boarding are

painted with three coats of Blake's mineral paint, which effectually protects them against damp. The side wall of the two end boxes is boarded to correspond in height and capping with the partition on the opposite side of the box.

A cheaper separation between the boxes may be contrived by diminishing the quantity of iron work, and substituting single for double boarding, and employing deal instead of oak for the posts and capping, which no doubt would answer the purpose very well in many stables, although it would not be equally durable, nor withstand an equal amount of hard usage without damage. When single boarding is used, it is of importance, that it should be placed lengthwise, and not upright; the disadvantage of the common practice of placing the boarding upright is, that a horse in kicking against it strikes the wood across the grain, and stands a very good chance of splitting two boards at a time, whereas the longitudinal boarding, being hit in the direction of the grain, springs to the blow, and very rarely sustains any great injury.

Well seasoned elm is the toughest and cheapest wood, and if it were not for its great tendency to warp, it would be the best to employ; but warping is such a serious objection, that good red deal will perhaps be found the best, and the cheapest in the end; the boards should be an inch and a quarter thick, and grooved into each other, and also into the posts, of which there should be three in each partition, one placed in the centre, and one at each end; they should be five inches by four inches in substance, and at least seven feet high, but the partition would be stronger, and better able to resist any pressure from the horse, if the front and

centre posts reached to the ceiling, and were framed into the floor joists above ; their corners should be removed by a broad chamfer, and their lower ends charred and pitched, and let eighteen inches into the ground.

The boarding between the back wall and the centre post may be carried seven feet high, and the uppermost board grooved into a straight deal capping, two and a half inches thick and three and a half deep, morticed and pinned into the back and centre posts. The boarding between the centre and end posts may be five feet high, with a straight capping surmounted by five-eighth round bars of iron, placed an inch and a quarter apart, and riveted into a top and bottom rail, so as to complete the height to seven feet. The ends of the top rail may be turned up and screwed to the posts, and the bottom rail screwed to the capping. If the bars are placed at a greater distance from each other, the horses will be very apt to nip pieces out of their neighbours' lips through the openings.

The boarding of the front should be similar to that of the partition, but it need not be more than four feet high including a rail eight or nine inches deep and an inch and a half thick, which should be morticed into the post at the end, and also into the post, to which the gate is hung ; the iron work, which surmounts it, may be like that of the partition, with the exception of the space between the bars which may be increased to two inches. The gate should be at least thirty-seven inches wide, and the styles and top and bottom rails should be three inches broad and an inch and a half thick ; the centre rail may be eight or nine inches deep, and

the boarding of the lower portion, and the iron work of the upper portion made to correspond with the front of the box. The post, to which the gate is hung, should be of the same dimensions as the other posts, and if it were carried up to the ceiling, and framed into the floor joists, the front partition would be greatly strengthened, and the gate would work truer, last longer, and be less shaken by use.

MANGER.

It has always appeared to me, that iron is a cold, uncomfortable material for a horse to feed out of, particularly in winter, when its surface is wetted all over by the condensed breath of the horse, and the moisture which is contained in the atmosphere; and it is practically objectionable for a hot mash, which is converted into a cold one, before the horse can have disposed of half of it. I have therefore had my mangers constructed of wood; they are partly of oak and partly of deal, and I find that they answer particularly well: the sides and ends are made of deal an inch and a half thick, and the capping and bottom are of oak, the former three inch oak, rounded on the top, and the latter a slab two inches thick, rabbeted into the deal sides and ends: the bottom of the manger receives a further support from the casing of the supply pipe, which is carried beneath the manger, and secured to the back wall, and also from a rounded piece of deal placed under the front. The mangers are three feet seven inches high, measured from the floor to the top of the capping, thirteen inches wide at the upper part, nine inches wide at the bottom, and eleven inches deep.

It is a mistake to have a manger either narrow, or shallow, for in the first case, the horse is deprived of the free use of his lower jaw in masticating his food, unless he raises his head for the purpose, and in the other he is very apt to waste his food by turning it out of the manger with his nose. The portion of the manger, which is appropriated to the horse's feeding, is three feet long, and has a water tank adjoining it at one end, and a corn and chaff shoot descending into it at the other end, and has also a two inch round bar fixed across it, at three inches from the water tank, to prevent the horse tossing his food into the water with his nose, Fig. 1, Plate V.

The water tank is made of cast iron, enamelled on the inside, and is eleven inches square at the top, eight inches square at the bottom, and seven and a half inches deep. The corn shoot is fifteen inches by fourteen, and is formed of inch deal, wrought and tongued, with a sloping board in the lower part, to incline the food towards an arched hole in the front, which opens into the manger, Figs. 1 and 2, Plate V. The shoot passes through the ceiling, and terminates above in a hopper, on a level with the floor of the loft, where it is covered by a hinged flap. The manger is continued at a right angle from the shoot against the partition for the space of twenty-two inches, and is divided into two compartments, one twelve inches long for the reception of rock salt, and the other nine inches long for a lump of chalk, two substances which my horses are supplied with at all times, and which greatly tend to keep them in health.

The mangers are supported on standards, three inches square, and the spaces between the standards at the ends of the manger are filled by inch and a half boarding, to form clips for confin-

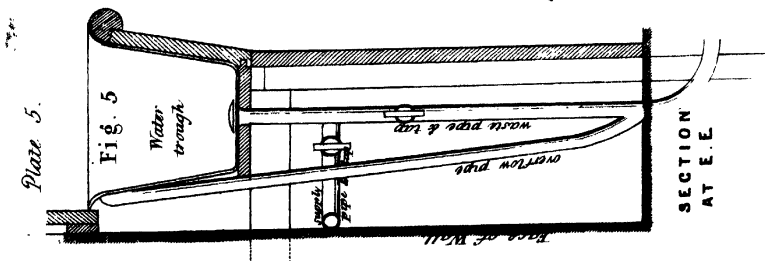
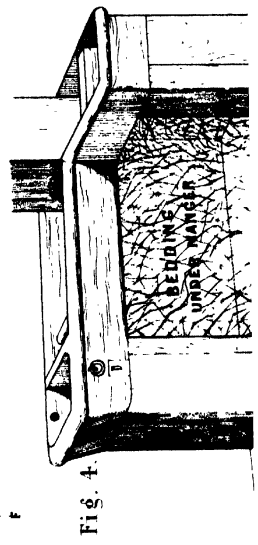
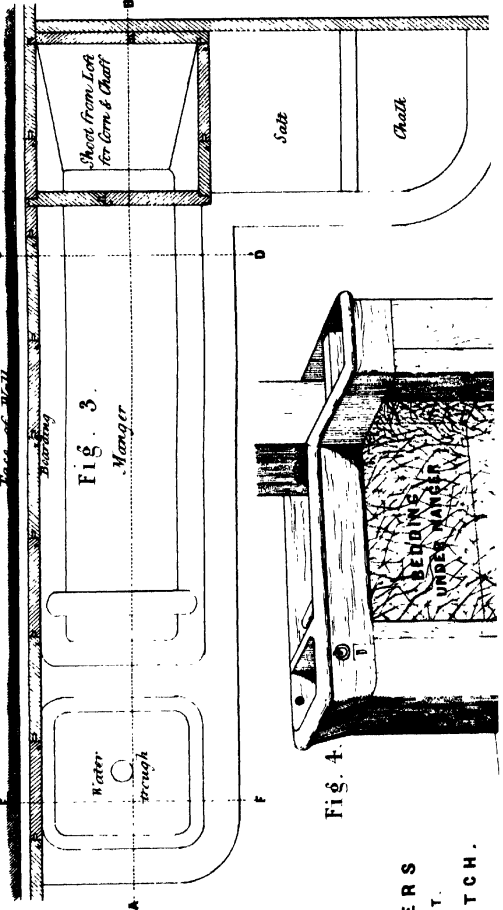
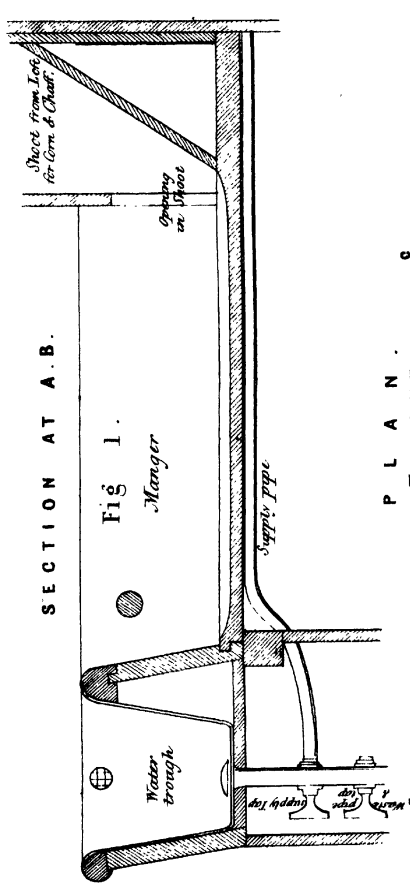
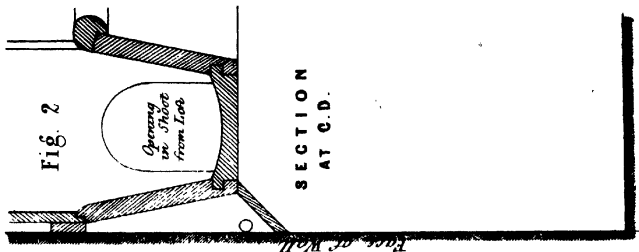

DETAILS OF MANGERS
SCALE ONE INCH TO A FOOT.
& PERSPECTIVE SKETCH.

Plate 5.

ing the bedding during the day. The space under the water tank is entirely enclosed by two inch deal, for the protection of the supply and waste pipes, and has a small door placed in the end for the convenience of ready access to the taps; there is also a ring and roller inserted in the front, to provide the means of tying a horse up in case of need; they are both larger than those in common use, and the roller is made of lignum vitæ, and turns on a stout brass axle, which is much better than iron for the purpose, as it does not rust, or become fixed. Fig. 4, Plate V., shews a perspective view of the manger, water tank, corn shoot, &c., complete, and this together with the other figures of the same plate will shew the details more clearly, than I can describe them by words.

WATER SUPPLY.

Water is carried to the boxes and other parts of the premises from a cistern, four feet square and two feet six inches deep, which is placed in the loft, and is always amply supplied with water.

A separate pipe for each stable passes from the bottom of the cistern under the floor of the loft to the back wall, it then appears on the surface, and is carried along the floor close to the wall, and sends off a branch, which descends behind the corn shoot of each box to the bottom of the manger, beneath which it is carried to the water tank. A stop cock is attached to each of the supply pipes a few inches from the cistern with access to it by means of a trap door in the floor; this arrangement enables the water to be cut off from one stable without

interfering with the other, and it is further useful in periods of severe frost for stopping the supply at the cistern, and emptying the pipes from below, whereby the necessity of emptying the cistern itself, to prevent the pipes bursting, is avoided. Fig. 5, Plate V., shews the relative position of the supply, waste, and overflow pipes; and it will be seen, that by means of a stop cock the waste pipe is made to perform the double office of filling, and emptying the tank, for when the supply is turned on, and the waste turned off, the water is forced upwards, and passes into the tank through a hole in the bottom, which is covered by a brass cap three inches in diameter, and raised about the eighth of an inch from the opening of the pipe, into which it is screwed. The cap being thus raised, causes the water to flow under it along the surface of the bottom of the tank, and prevents the rush and spurting up, that would otherwise occur. When the tank is full, the overflow passes off by a pipe, one end of which opens into the tank, and is covered by a grating of wire, Fig. 1, Plate V., and the other is inserted in the waste pipe below the stop cock; from this point the waste pipe is continued beneath the floor, and terminates in the side of the pit which is in the centre of the box, and conveys the overflow and waste water through the pits to the drains, which can be readily and efficiently flushed by filling the tank, and permitting the supply to flow on, after the stop cock in the waste pipe has been turned, to allow the water to pass downwards; this, and a few pails of water occasionally thrown off to the floor, and swept into the pits, keeps the stable clean and free from smell.

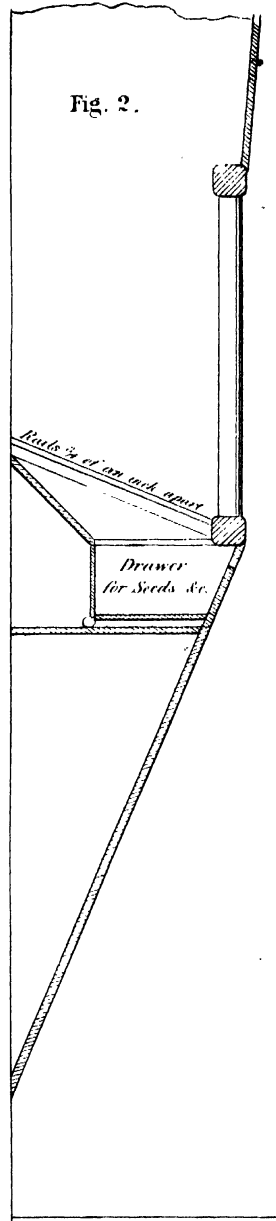
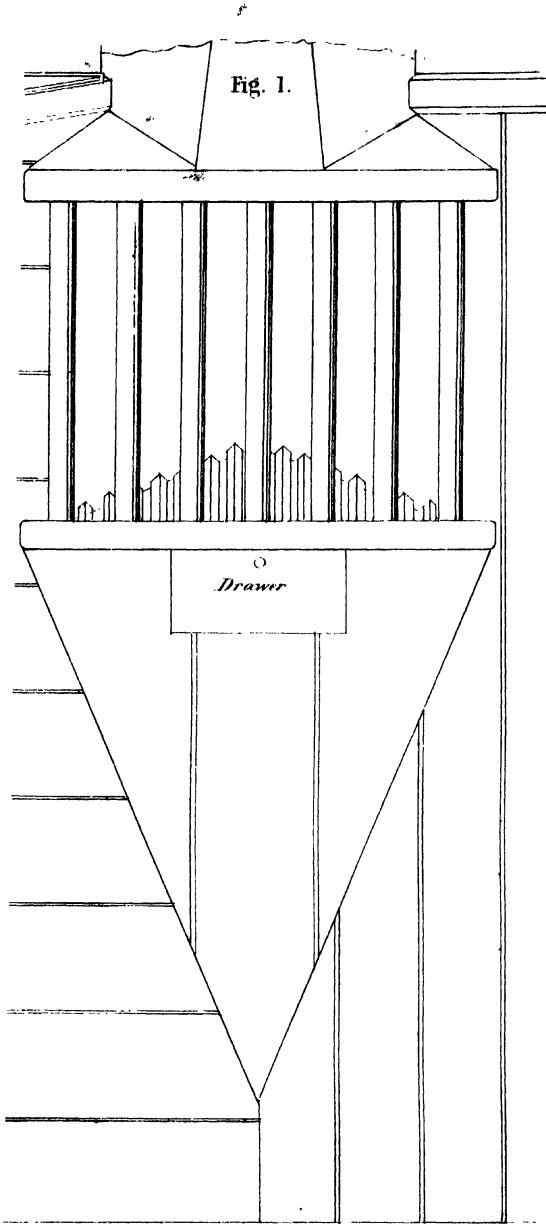

ELEVATION

SECTION.

Fig. 3.

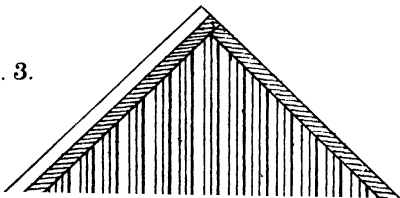

DETAILS OF HAY RACKS.

SCALE ONE INCH TO A FOOT.

RACK.

The most convenient situation for the rack is the left hand corner of the box, where the horse can obtain a ready access to it; and I much prefer a wooden rack, placed on a level with the horse's head, to the low iron one which I frequently see in use; for besides the chance there is of a horse getting his feet into a low rack, when he is either frolicsome, or alarmed, it is open to the objection, that he is constantly hanging his head over his food, and breathing on it while he is feeding, which renders the undermost portion of it moist and warm; and makes him reluctant to consume the whole of it. No doubt a horse does sometimes pull out and waste some of his food from a raised rack, but I question whether he wastes as much from a high rack, as he spoils in a low one; and the portion he does eat is fresh, and free from the moisture, caused by his having breathed on it.

The rack staves should be perpendicular to the face of the boarding, for, if they incline at all forward, the hay seeds are apt to fall about the horse's head, and produce considerable irritation and annoyance by getting into his ears and eyes.

Fig. 1, Plate VI. represents the rack in the left hand corner of the box, thirty inches broad, twenty-four inches high, and sixteen inches deep from back to front in the centre. The rack staves are round, two feet long, an inch and three quarters in diameter, and three inches apart; they are made of oak, and are placed perfectly upright: the upper and lower end of each stave revolves in a top and bottom rail, two and a half inches broad, and two inches deep, also made of oak.

The front edge of the bottom rail is rounded, to enable the horse to clear the rack more readily; and the under part of the rack is formed of rails one inch broad, and one and a half deep, raised at the back part, and sloping towards the front; the upper portion of each rail for about an inch is splayed on both sides in the form of a prism, the lower portion remaining square, and the space between the rails at this part is three-quarters of an inch, which permits the hay seeds to fall into a kind of hopper, beneath the rails, formed by boards sloping from the back and sides to the edges of a drawer below, which catches the seeds, and keeps them out of the reach of the horse, Fig. 2, Plate VI.

The space below the rack is enclosed by inch boarding, which extends across the corner of the box, and inclines gradually backwards and downwards for three feet ten inches, where it terminates in a point in the angle, so as to leave neither edge, nor projection to endanger the horse's head; and in this sloping front, the drawer, which measures twelve inches by ten at the upper part, twelve by eight at the lower part, and five inches deep, is placed, having a circular finger hole in the front for the convenience of drawing it out, which no exercise of ingenuity on the part of the horse will enable him to do for himself.

A rack should always have a drawer under it to catch the hay seeds, for if they are permitted to lodge in the bottom of the rack, and are not frequently cleared away, they become mouldy, and taint the fresh hay: some horses contract the habit of pulling out the hay merely for the purpose of obtaining the seeds, and repeated disappointment will sometimes induce them to discontinue the practice.

Fig. 1.

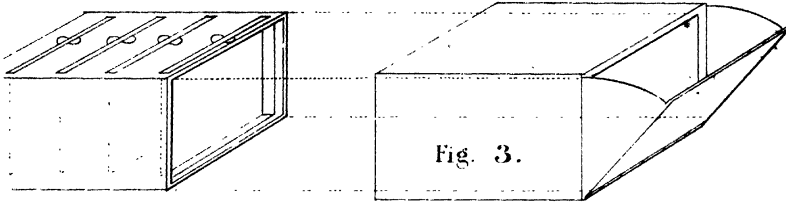
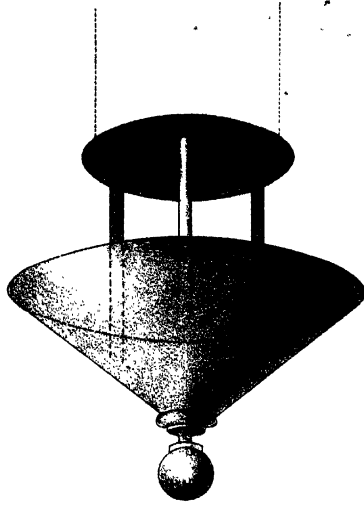

Fig. 3.

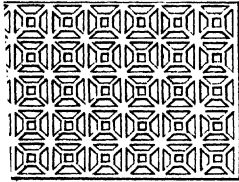

Fig. 6.

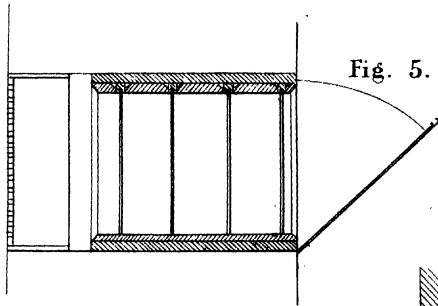

Fig. 5.

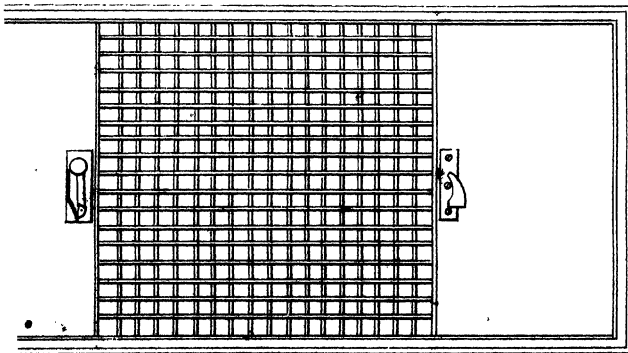
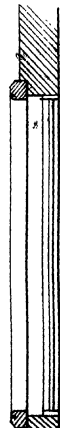

Fig. 7.



RAWAB SALAR JUNG BAHADUR

VENTILATION.

The great aim of ventilation should be to furnish an ample and continuous, but nevertheless controllable supply of pure air to the horses, and at the same time to carry off the impure air as quickly, as possible without creating a perceptible draft in any part of the stable below two feet from the ceiling; and this I have succeeded in accomplishing with the assistance of Mr. Scott, of Exeter, whose registered "air regulator," and practical knowledge of the art of ventilation have enabled me to maintain a most satisfactory atmosphere in my stables as well by night, as by day at all seasons of the year.

In some stables I have seen provision made for the admission of air by leaving out two or three bricks close to the ground; but this is a very objectionable plan on account of the large mixture of carbonic acid gas and other impurities, usually combined with the stratum of air, which floats near the ground, emanating from drains and decomposing matter lying on the surface. It is far better to obtain the supply from a height of eight or nine feet from the ground, where the air is for the most part tolerably pure.

When the weather is such, as to make it imprudent to open a window, the supply of air for the horses is effected by three "air regulators," placed at intervals in the wall, with their upper edges two feet from the ceiling; they each consist of two oak cases open at both ends, Figs. 2 and 3, Plate VII., the inner one being made to slide easily into the outer, which is fixed in a hole ten inches by nine, extending through the thickest part of the wall, with an iron grating inserted

in the face of the brick work, to cover the outer opening, Fig. 4, and a hinged tin flap with tin sides, to cover the inner one, Fig. 3; a crevice being left on each side of the wooden case for the sides of the flap to work in, to regulate the quantity of air, admitted through the opening. It will be seen by Fig. 3, that the air may be permitted to enter the stable either in a direct line, or be made to ascend towards the ceiling, by merely pulling the flap forward, or pushing it backward. The inner case is divided into compartments by plates of zinc, perforated by holes of various sizes, which break the force of the current, and diffuse the air through the stable without causing a draft below. The number of the plates must depend on the aspect of the stable; in very exposed situations it may be necessary to employ four or five, but in ordinary cases three will be sufficient, and the best arrangement of them will be to place the one with the largest holes about an inch within the external opening, the one with the smallest holes in the centre of the case, and the third with holes of an intermediate size at the inner opening. Each plate should have a slit made for it in the upper part of the case, and corresponding grooves in the sides, to permit it to drop easily into its place, Fig. 5. In summer the inner case may be removed altogether, and in winter it should be occasionally withdrawn, and the plates taken out and brushed; otherwise they will become blocked by dust, and rendered impervious to the air, more especially the centre one. A further provision for the admission of air, independent of the windows, is made by an opening 18 inches by 15, in the stable door, guarded on the outside by wirework, and on the inside by sliding shutters, which meet and fasten in the centre, and can be

opened little or much according to the state of the atmosphere within and without; Fig. 6 and 7, Plate VII. The upper edge of this opening is placed below the level of the rails of the boxes, to prevent a direct current of air blowing into the box, that is immediately opposite the door.

The impure air is carried off by zinc tubes, which open on the face of the ceiling and pass through the floor, near to the back wall of the loft, up the incline of the roof, and emerge at the ridge, terminating in a top, made on the principle of Day's wind-guard chimney pot, which keeps out the rain and prevents a down draft; Fig. 2, Plate III. Each box is furnished with one of these extraction tubes, six inches in diameter; three have them over the centre of the manger, and the fourth in the upper part of the shaft leading to the sky light, with a view of removing the impure air from the highest point of the stable; Fig. 2, Plate III.

The lower end of each tube has a cup, ten inches in diameter, Fig. 1, Plate VII, capable of containing three pints of fluid, suspended under it by three supports, attached to a broad rim which slides into the tube for the convenience of removal in case of necessity, leaving a space of four inches between the upper edge of the cup and the mouth of the tube all round for the passage of the impure air. This cup, which hangs suspended from the ceiling, acts very beneficially in preventing an accidental down draft falling on the horses, and also by collecting and retaining the moisture, which, having passed up the tube mixed with the heated and vitiated air, becomes condensed and separated by the cold above, and returns in the form of water, in quantities that would surprise

any one, who had never specially noted the amount of moisture, which clings to the walls, boarding, and iron work of a badly ventilated stable, and hangs about the clothing of the horses in a cold and wet season; an evil from which I desired to see my stable entirely exempt; and in order to ascertain whether I had succeeded, I exposed the ventilation in the early part of last year to the severest test, I could think of, by having the walls and ceiling painted with four coats of paint, the last coat being largely mixed with varnish, to render the surfaces unabsorbent, and I was not able to detect a drop of moisture on any of the surfaces in the stable excepting the glass during the whole of the last unusually severe winter; it had all been carried up the tubes with the impure air, and returned condensed into the cups beneath; and when the external atmosphere was very cold, they were filled to overflowing in about 48 hours. It rarely happens in any winter, that they go longer than three days without requiring to be emptied, which may be readily effected by the groom standing on the edge of the manger, and removing the contents by means of a sponge. The cups require scarcely any attention in warm and dry weather, for the water, that is collected by night, is evaporated by day. The small amount of trouble necessary to keep the cups empty is amply compensated by dry surfaces, for nothing can impart a greater air of discomfort to a stable, than finding every thing in it wet and sticky.

A gentleman, who had been much pleased with the atmosphere of my stable, employed Mr. Scott to ventilate *his* stable on the same principle, and the result was most satisfactory, until

the wet and cold season set in, when his coachman began to complain, that the rain came down the tubes, and fell on the horses' heads, and into the manger; and he was persuaded to send for a mason, to remove the tops and stop the openings; which effectually cured the dropping from the tubes, but alas the disagreeable atmosphere and damp surfaces all returned, and he applied to me to ask, if I could help him out of his difficulty. I listened to his tale, and then informed him that he had proved the ventilation *to have been* perfect, but had very imprudently destroyed it, and I advised him to engage Mr. Scott to undo all, that the mason had done, and reinstate it in its former condition, and to desire his coachman to empty the cups occasionally with a sponge, and I had no doubt, but he would hear no more of the rain descending through the tubes. He followed my advice, and I understand that his stable has been dry and comfortable ever since.

The coachman's complaint was a very natural one, for at least a pint of water must have dropped into each manger every day, and as it happened that neither he, his master, nor the mason were philosophers, they of course jumped to the conclusion, that it *must be the rain*.

Before I pass on to another subject, it may be well to insert a caution against any attempts to carry off the impure air without at the same time making provision for the admission of fresh air, as it will inevitably end in disappointment; for the heated and exhausted air of the stable becomes so light, that the weight of the external air will always act as a stopper, and prevent its escape, unless it is backed by a good supply

of fresh air from below. I have seven openings in my stable communicating with the external atmosphere, by any or all of which fresh air can be admitted, viz., three windows, three air regulators, and the hole in the lower portion of the stable door; and there are seven outlets for the impure air, viz., four in the boxes, one immediately within the stable door, one over the lamp in the stable, and one over the landing at the head of the stairs leading to the loft; by this distribution of openings for the admission and egress of air every part of the stable is thoroughly and evenly ventilated, which can scarcely happen, where the escape of the foul and exhausted air is made to depend on only one or two openings.

LIGHT.

The beneficial influence of an ample supply of light on the health and condition of the horse is very little understood, and is not only frequently overlooked in the construction of stables, but is even considered by some persons to be a positive evil; for they assert, that horses thrive better, and become more lively in dark stables, than they do in light ones; the first part of the assertion is very questionable, but the second part is undoubtedly true, for the poor animals are so scared at being suddenly withdrawn from semi-darkness, and exposed to the glare of broad day-light, that they stare at everything, and jump about as lively as birds, until they have become thoroughly reconciled to the change; but this ebullition of spirit must not be placed to the account of health and condition, when it is merely the natural effect

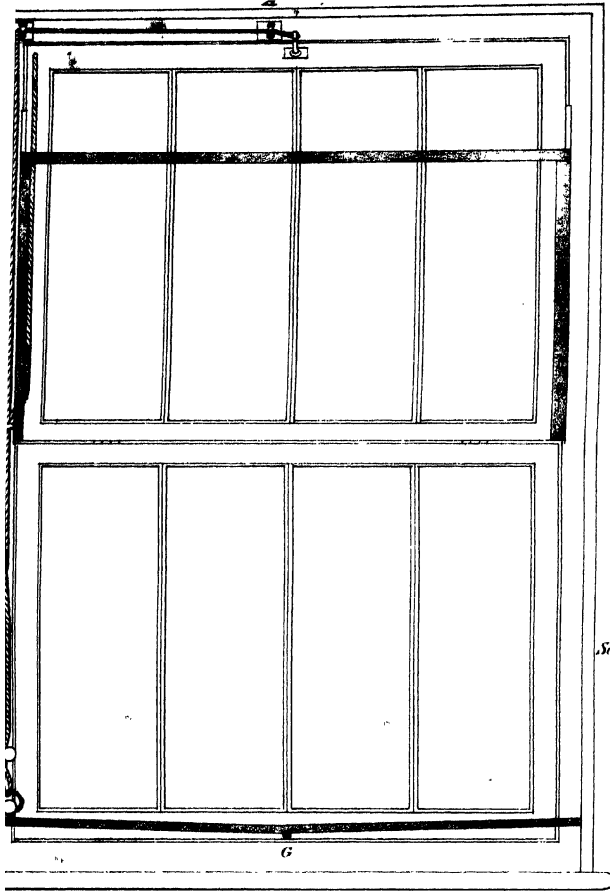
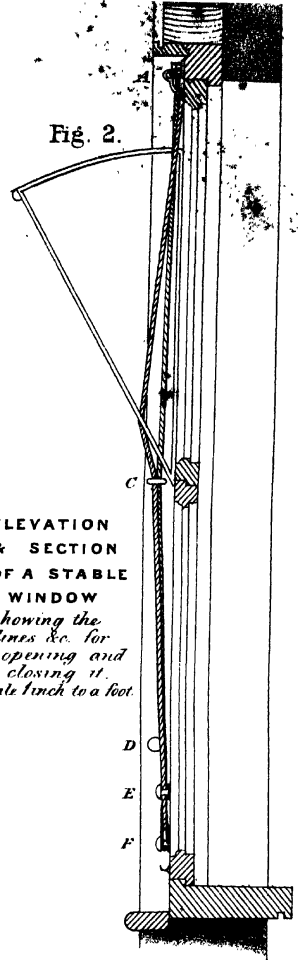

Fig. 2.



ELEVATION & SECTION OF A STABLE WINDOW showing the lines &c. for opening and closing it. Scale 1 inch to a foot.

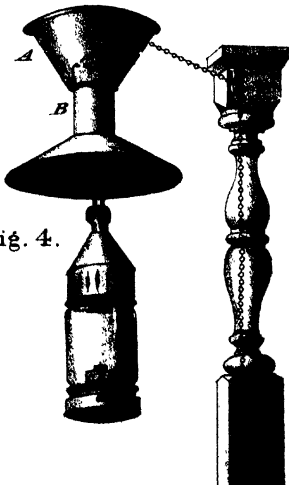

Fig. 4.

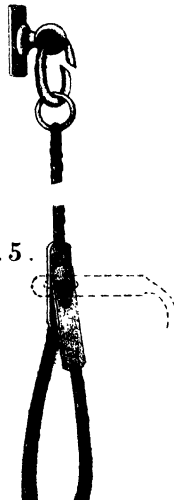
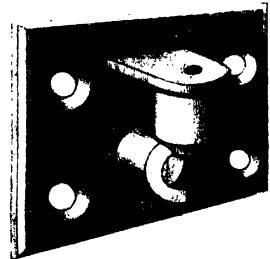

Fig. 5.

Fig. 3.



of nervous alarm, caused by the altered circumstances in which they find themselves placed. I believe as a general rule, that a stable can scarcely have too much light admitted into it, provided the direct rays of the sun are kept out; but the openings for the windows are usually made too small, and the panes of glass are neither large enough, nor clean enough to transmit a sufficient quantity of light.

I have made ample provision for the admission of light into my stable by the introduction of four windows and a sky light, viz., two large windows in the front wall, 5 feet 3 inches high by 3 feet 6 inches wide, measured within the sash frames, one smaller one over the stable door, 4 feet wide by 2 feet high, and another of similar dimensions over the door which leads from the stable to the harness room, the latter however is only a borrowed light, nevertheless it admits a full quantity, being placed very near to a large window in the harness room. The sky light measures 4 feet by 3, and is fixed in the roof of the loft immediately over box 4, and transmits light into the stable through an opening, 6 feet by 4, made in the ceiling of the box. The space from the ceiling to the roof is inclosed on three sides by sloping boarding, the fourth being completed by the end wall of the stable. The situation of the opening in the ceiling is indicated by the dotted lines on the floor of the box in Plate I., Fig. 2, A, and the boarded inclosure is seen passing through the loft to the roof in Plate III., Fig. 2. The larger windows consist of two separate sashes hinged together across the centre, Fig. 1, Plate VIII., the lower one is glazed with thick reeded glass, to prevent persons looking in and disturbing the horses,

and is firmly fixed in the frame; the upper one is glazed with clear glass, and is made to open inwards and fall into an iron frame which projects a foot from the wall at its upper part, as shown by Fig. 2, Plate VIII. The triangular space marked B is filled with glass, to provide against a side draft.

The sash is opened and closed by means of a line and pulleys, one end of the line is attached to an eye, screwed into the top rail of the sash about an inch to the right of the centre, to avoid collision with the centre pulley, when the window is closed, Fig. 1, A, Plate VIII. The line passes over this pulley to a similar one, placed in the left hand corner of the frame B, and descends by the side of the style to the stud marked F, it is then carried upwards to an eye in the sash, just under the corner pulley; but before the end is secured to the eye, it is passed through a brass ring, which from its weight falls down the line, and always remains at the loop formed by the ascending and descending portions of the line, whether it be at D, E, or F.

When the window is opened as wide, as the iron frame will permit, the loop and ring will be found at D, when it is half open, they will be at E, and when closed at F, and the ring being passed over the head of the stud will keep the line tight, and the sash in the desired position, secure from the action of the wind.

A hook, screwed into the wooden frame where the line crosses the iron frame at C, will be found very convenient for keeping the two portions of the line from separating and hanging down in the way of passers by, when the upper sash has been secured in its position by the ring and stud.

The letter G marks a small copper gutter, extending across the sash just below the glazing, to catch the condensed moisture, that collects on the inner surface of the glass in cold weather; it is raised at each end, and gradually lowered towards the centre, where a small tube, about a quarter of an inch in diameter, is attached to it, and passed diagonally through the wood-work to the outer window sill, from which I have seen on several occasions in severe weather a broad surface of ice, extending down the outer wall to the ground, which would have been deposited in the form of water on the floor of the stable, if it had not been for the outlet thus provided.

I had some difficulty in procuring a pulley, that would work easily and without friction, until I had one made in the form represented at Fig 3, which answers the purpose so well, that many persons have already adopted it, and applied it to various purposes, where it was desirable to diminish friction, and prevent hitching. It consists of two cylindrical brass rollers, half an inch in diameter, placed at a right angle to each other, and turning on a stout iron pin, which is bent in the centre, and riveted through a plate, that projects about an inch from the back plate at its upper end, and through the back plate itself at the lower end. The centre of the pin at the bend is nearly square, forming a shoulder above and below, to keep the upper and under rollers from coming in contact and impeding their free action, which is further aided by bevelling the end of each roller towards the shoulder; leaving an opening of about half an inch for the line to work through, which it does without the slightest friction by turning both rollers, whenever it is moved in either direction.

Fig. 4 represents a very efficient and convenient stable lamp, which affords a remarkably good light and can be employed as a safe lantern; it consists of a cylinder of very thick glass attached to a metal cap above, and a broad circular band below, with a pin projecting from each side of the latter, which fits into an angular slit on each side of the frame, that contains the oil lamp, confining the two portions of the lamp together. The chimney B moves with the lamp, and slides into the tube A, when the lamp is in its place against the ceiling; it is attached by a wire across the upper opening to a chain, which works over a pulley concealed in the tube A, and passes out through a hole in the side, close under the ceiling, to another pulley screwed into the side of the post at the end of the partition, and then through an eye lower down, where a ring is affixed to it, to be passed over a knob placed further down the post for securing the lamp, when it is drawn up; and the same ring prevents the chain slipping through the eye and letting the lamp fall, when it is lowered for the purpose of being removed, and used as a lantern. The object of the zinc tube is to carry off the smoke and heated air, and pass them through the loft to the roof.

PILLAR CHAINS.

The usual mode of securing a horse in a stall or box, when he has been bridled and turned about, is by billets and buckles, or spring swivels attached to pillar reins; but as the buckles and springs are apt to become rusty and act imperfectly, after they have been exposed to the atmosphere of a stable for a

short time, the difficulty and delay attending the freeing of the horse, frequently disturbs the equanimity of the temper of horse and master alike, and causes them to commence their journey under very unfavourable circumstances; this can however be avoided for the future by the adoption of a very simple and convenient fastening, for which I am indebted to a gentleman, who paid a casual visit to my stables three years ago. It consists of two plates of brass, three quarters of an inch broad, and the eighth of an inch thick, attached to a rein, or chain; one of the plates is affixed to the lower end, and the other is placed about 16 or 17 inches higher up. The upper one is two and half inches long, and has a flat-headed stud, five eighths of an inch in its longest diameter, securely fixed across the centre with the two ends projecting beyond a neck below, very much like the stud, which usually fastens a carpet bag, but with this important difference, that it must be firmly riveted through the plate, and rendered *immovable*. The lower plate is three and a half inches long, and has an eye cut in it lengthwise, about five eighths of an inch from the point, just long enough and broad enough to pass easily over the stud, when the two plates are brought together at a right angle with each other, but not so broad as to prevent the eye clipping the neck of the stud beneath the projecting ends, when the lower plate is turned downward, to complete the fastening. Fig. 5, Plate VIII, shows the relative position of the two plates, when the lower one has been passed through a ring of the bit, and brought back to the upper one; for the purpose of securing the horse; and the dotted lines indicate the posi-

tion, in which the lower plate must be held, before the eye can be passed over the stud. It will be at once perceived, that however violently a horse may toss his head, he can never bring the lower plate to a right angle with the upper one on *either* side, while he is thus secured on *both* sides, and consequently he cannot free himself; but his master can free him without the slightest inconvenience by turning the lower plate, as shewn by the dotted lines, lifting the eye off the stud, and drawing the end of the chain through the ring, which can be accomplished with the hands removed eight or nine inches from the froth and moisture of the horse's mouth.

I employ round-linked chains, five eighths of an inch in diameter with leather sewn tightly round them, as pillar chains; and for the convenience of removal, when they are not in use, each chain has a stout brass ring, an inch and three quarters in diameter, attached to the upper end of it, which drops into a slanting opening in the side of an iron ring; one of these rings is screwed against the post in the middle of the partition, and another against the post to which the door of the box is hung. The ring should be fastened to that side of each post, which is the furthest removed from the door of the box, and the split side should be turned away from the horse, and placed as high up the post, as a man can conveniently reach, to insert the brass ring. The chains should be neither too short, nor too long, for in the former case the horse will be unnecessarily restrained, and in the latter he will thrust his head into the corner of the box, and damage his bridle by rubbing it against the sides.

CUPBOARDS.

A littered and slovenly stable is a very unsatisfactory spectacle, denoting want of care, or want of accommodation. "A place for everything, and everything in its place" should be the prevailing rule in every stable, but, unless the groom is provided with closets and cupboards, it is almost impossible for him to comply with it; it can however be easily accomplished by placing a skeleton front across any spare corner; which at once converts, what was useless space into a useful depository for *something*. I have placed one immediately behind the entrance door of the stable, which reaches from the floor to the ceiling, but occupies no more available space, than was previously shut off every time the door was opened; it now however supplies a convenient location for forks and brooms, and sundry other things, which must otherwise have been deposited about in the stable, or removed to an inconvenient distance from it. The under part of this inclosure forms a closet nearly seven feet high, and the upper part a useful corner cupboard. There are two somewhat similar inclosures on the opposite side just within the door; the first abuts against the door post, and is three feet long by two feet deep, and reaches from the floor through the ceiling to the loft, where it is covered by a trap door, and serves for the passage of the bedding from above, and the raising of corn and other heavy things from below by means of a crane, fixed in the loft; the second adjoins it, and extends across the corner to the front wall of the stable, and forms three very

convenient corner cupboards, placed one above the other. A two-fold object is gained by carrying these inclosures to the ceiling; first a larger amount of accommodation is obtained by it, and secondly the accumulation of dust and dirt on the tops of the cupboards, which would necessarily arise, is avoided. Double doors with a finger hole in one, and a wooden button attached to the other, are preferable to single ones, as occupying less space when open, and being altogether more convenient to the groom. The situation of these inclosures is shown by the letters F and G in Fig. 2, Plate I; and the letter E in the same Fig. marks the place of a broad seat against the end wall of the stable, raised sufficiently high from the ground to receive three stable buckets beneath; and I may here observe, that iron buckets possess many advantages over wooden ones, they are thinner, and lighter, they are not absorbent, and therefore less likely to retain either the taste, or smell of what they last contained, they are more easily kept clean, and they last a great deal longer.

COLOURING THE WOOD-WORK.

Staining and varnishing the wood-work in a stable is far preferable to painting it; the varnish preserves the wood quite as effectually, as paint could do, and if the staining is properly performed, the surface will always remain free from the uncomfortable, clammy feeling, presented by a painted surface in wet weather; it has moreover the advantage of retaining its colour for many years, being uninfluenced by the gases which are generated in the stable, and which soon begin to affect

the colour of paint, making it darker and darker, until in the end it becomes almost black.

The staining material should be as simple, as possible ; raw sienna and raw umber in the proportion of one part of raw umber to five parts of raw sienna, ground in water, and mixed with equal parts of vinegar and water, make the best staining fluid, that can be used for wood-work in stables, or anywhere else. The proportions I have given above produce a very good colour for stables, but it may be varied by the diminution, or addition of raw umber, to represent every gradation of colour from that of satin wood to dark oak ; great difficulty however is experienced in persuading workmen, that the addition of a little *beer* will not improve the mixture ; they all appear to think, that beer cannot harm anything, nevertheless it does harm the staining fluid, and if it is desired to have the staining well done, the beer must be kept out of it, for beer contains a glutinous matter, which continues soft for a long while under the varnish, and prevents it drying hard and solid, as it should do ; causing it to feel sticky particularly in close, damp weather, and, when the spirit has entirely evaporated from the gum contained in the varnish, it contracts, and covers the surface with cracks and fissures in all directions.

The same objection applies to all the staining fluids of commerce, they all contain either glutinous, or oily matter ; and the varnish never can become properly dry and hard over them.

The mixture, recommended above, is free from any such objection, the vinegar and water evaporate in the course of a

few hours, leaving the pores of the wood filled with the colouring powder, which incorporates with the varnish, and, drying with it, adheres firmly to the surface of the wood. The mode of dealing with it is very simple, it only requires to be laid on liberally with a clean, and tolerably stiff painting brush, and then left to dry ; no especial care need be taken in putting it on, for when it has become dry, any superfluous powder, that may remain in streaks on the surface, can be readily removed by a painter's dusting-brush, which may be freely used without the fear of disturbing the deposit in the pores of the wood, on which the colour to be imparted, mainly depends.

When the stained parts are dry, and have been well dusted off, they should receive a coat of varnish, and after a few days it should be followed by a second, to cover those portions of the work, that may have sunk in, and become dull. It is of great importance, that the varnish should be good ; and of nearly equal importance, as regards its durability, that it should be used in warm, dry weather.

The oak posts do not require to be stained, but they will keep clean and retain their colour much longer, if they are also varnished ; they must however have the surface shielded by a thin coat of size, applied quite hot, the day before the varnish is used, otherwise the varnish will turn them black in irregular patches.

HARNESS ROOM.

The space, I have been able to allot for a harness room, is much smaller, than I could have wished it to be, viz., 15 feet long and 7 feet 6 inches broad for the first 6 feet of the length, and only 6 feet broad for the remaining 9 feet, nevertheless by turning every available spot to account I have contrived to make it tolerably convenient. Fig. 2, Plate I, contains a general outline of the arrangement, and Plates IX and X show the various fittings in detail; there are however some things, which add considerably to the accommodation, that are not shown in either of these plates; for instance the recess by the side of the fire place not only contains the closet, marked in fig. 2, Plate I, which is 3 feet wide, 3 feet high, and 15 inches deep, but has a vacant space of the like dimensions left above it, which forms a very useful depository for temporary purposes, and between that open space and the ceiling there is a cupboard, 4 feet 4 inches wide, 4 feet high, and 15 inches deep; the increased width was obtained by stopping the brick pier on that side of the fireplace four feet short of the ceiling, so as to let one end of the cupboard reach the shaft of the chimney, whereby an ample and warm place was provided for spare horse clothing, &c. in space, that would otherwise have remained unappropriated.

Again, keeping in view the necessity for economizing space as much, as possible, the recess for the reception of harness, marked in fig. 2, Plate I, was obtained by substituting double boarding for brick-work as a separation from the stable, and

projecting the sides six inches beyond the face of the adjacent wall, whereby a commodious wooden case, 5 feet wide, 8 feet high, and 2 feet deep, was formed, and is inclosed by curtains to shield the harness from dust and dirt; leaving room for a cupboard, 5 feet wide, 2 feet deep, and 23 inches high, between it and the ceiling. The outer surface of each of the projecting sides is also turned to account, the one nearest the door leading to the stable has the pillar chains hung to it, when they are not required in the boxes, and it also guards the end of a moveable bracket for cleaning saddles upon, shewn in Plate X, which can be closed up and turned against the wall out of the way, when it is not in use; the other, which projects two feet from the door of the closet under the stairs, forms a convenient place for a roller and towel.

It is always desirable in dealing with a confined area to render as much wall surface available, as possible, and I found that by making the door, which leads to the yard, open outwards instead of inwards, I should not only gain room to hang a flap and bracket, 3 feet 6 inches long, and 2 feet 2 inches broad, against the wall, to be used as an occasional table, but to provide a corner for a measuring standard, and also to introduce a ventilator in the wall, all which would have been lost, if the door had been made to open inwards.

Another convenience is the water being brought by a pipe from the cistern in the loft to the supply cistern for the boiler, marked in fig. 2, Plate I, thence into the boiler which extends across the back of the grate, and on to a tap in the corner, beyond the chimney-piece; by this

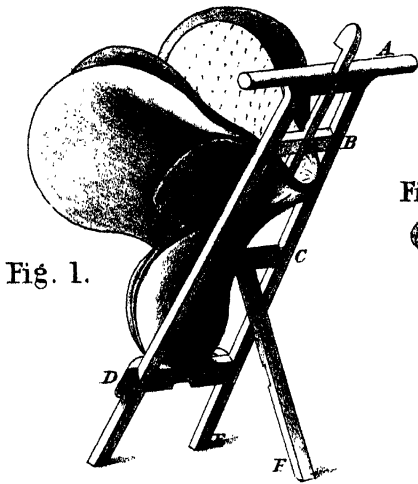

Fig. 1.

MOVEABLE STAND

Fig. 6.



SUSPENDING ROD FOR CLEANING HARNESS.

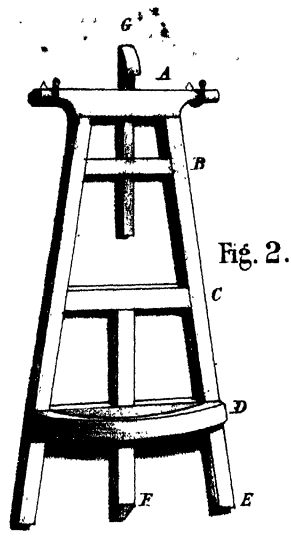

Fig. 2.

FOR DRYING SADDLES.

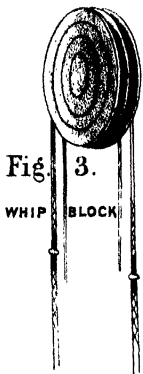

Fig. 3.
WHIP BLOCK

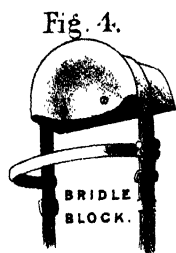

Fig. 4.
BRIDLE BLOCK

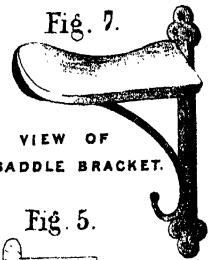

Fig. 7.
VIEW OF SADDLE BRACKET.



Fig. 5.
SECTION OF BRIDLE BLOCK

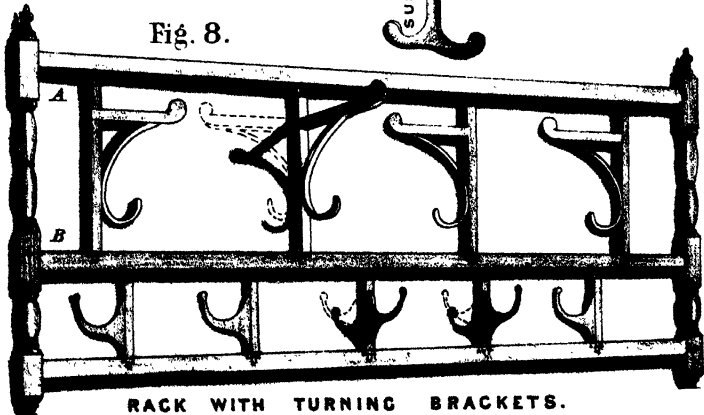

Fig. 8.

RACK WITH TURNING BRACKETS.

arrangement a good supply of water is always at hand, and the larger the quantity, that is drawn from the tap, the cleaner the boiler will be kept; when hot water is required, the fire must of course be lighted, and it is surprising, what an amount of very hot water may be obtained from a comparatively small boiler, if the first portion is allowed to continue boiling for some little time, so as thoroughly to heat the back and sides of the boiler, before any of it is drawn off.

Plate IX contains examples of harness room fittings. Fig. 1 and 2 represent a very useful stand, for drying the pannel of a saddle upon, that can be moved from place to place without disturbing the saddle, and saves it from numerous injuries, which are inflicted upon it by the usual mode of propping it up before a fire, or against a wall in the stable yard. Fig. 1, shows it extended for use, with a saddle properly placed on it; and fig. 2 shows it closed up out of use, and hung against the wall.

It should be made of well seasoned deal, an inch and a quarter thick, and the following dimensions will be found fully sufficient, to form a light, strong, and serviceable stand; viz. length from A to E 2 feet 11 inches, the sides and moveable leg F an inch and a half broad, the latter should have been drawn an inch longer, than the sides, the breadth at B from out to out 10 inches, at C 12 inches, at D 14 inches, and at E 15 inches. The top rail A including the handles should be 17 inches long, and 2 inches deep in the centre, the next two rails an inch and a quarter deep, and the bottom rail 2 inches and a half deep; the rail B should be

placed 3 inches below the lower edge of the top rail, C 10 inches below B, and D 8 inches below C; the rail C moves with the leg F, and is secured to each side-piece by a wooden peg, on which it works. The rail D has a place cut out in the back part, to receive the leg F, when the stand is not required for use, and an arched piece extending across the front, and fastened to each side by two wooden pegs, forming a tray, 10 inches long, an inch and a half broad in the centre, and an inch and three quarters deep throughout, to support the cantle of the saddle, when the stand is in use. The cantle being placed in this hollow, and the peg G pressed down in front of the pommel, renders the saddle perfectly secure, when the stand is moved. The peg G is 15 inches long, three quarters of an inch broad in front, and half an inch broad at the back and sides, and works through openings of similar form and size made in the back part of each of the two rails A and B, forming what is called a "dovetailed key." This key must be partly withdrawn to allow the pommel of the saddle to pass beneath the rail B, and when it is pressed down again in front of the pommel, to retain the saddle, the head will prevent its descending so low, as to pass through the openings.

Fig. 3 represents a whip block, that is to be met with at most of the saddlers and harness makers; but, as many of them are very imperfectly turned out of hand, I have introduced it here, for the purpose of directing attention to the defect I allude to, which consists in the centre portion being of nearly equal thickness throughout, and not bevelled on the sides, as it should be, to form a groove with

the front, or back of the block, wide at the external opening, and narrow at the bottom: the outer edge should be thin all round, and the thickness gradually increased, as it descends towards the bottom of the groove. When this centre portion is properly made, the crop of the whip can be kept in excellent order by placing the thick part of the thong lightly on the top of the block, and drawing the whip downward on one side, until the crop hangs clear of the block, and the thinner part of the thong becomes tied in the narrow portion of the groove on the opposite side; but when the centre portion is not sufficiently bevelled, the crop itself must be tightly jammed in the groove, or the whip will inevitably slip out of the block.

Fig. 4 represents a block, for hanging bridles upon, which preserves the head piece in good form, and is a great improvement on the hooks and pegs that are generally employed for the purpose. It consists of the half of a circle $5\frac{1}{2}$ inches in diameter, turned out of a piece of beech, or sycamore, 2 inches thick, and has a rim, three-eighths of an inch broad, extending round the edge, and projecting three-eighths of an inch above the surface, on which the bridle rests. The front is gradually hollowed from the outer rim towards the centre of the circle, until the substance has been reduced one half, in order to diminish the depth of the holes, through which it is to be fastened to the wall. The best way of making these blocks is to turn a complete circle, and divide it through the centre.

Fig. 5 is a section, drawn to a scale of one-third of the above dimensions, showing the relative size of the projecting

K²

rim, the place for the head of the bridle to rest upon, and the thickness of the upper and lower portions of the block.

Fig. 6 represents the rod I have adopted for cleaning harness upon, which answers the purpose admirably, and is easily removed out of the way of persons' heads, when it is not in use. It is made of iron, and is suspended from the ceiling by a strong iron loop, screwed into the joist above; the upper part of one side of the loop opens by means of a spring for the convenience of inserting, or removing the ring A, which is attached to the upper end of the rod.

The rod is divided into three portions, marked B, D, and F. The upper portion consists of a stout iron gas-tube, an inch and an eighth in diameter, outside measurement, with a slit in front extending from an inch above the lower end to within two inches of the top, where it turns at a right angle, and is continued for about three quarters of an inch. The lower end of the tube has a smaller tube, about half an inch long, brazed into it, to diminish the opening, and form a stop, to prevent the weight of the harness dragging the centre portion through, and separating the rod.

The centre portion D is also formed of gas-tube, five-eighths of an inch in diameter, with about an inch of a somewhat larger tube passed over the upper end, and brazed to it, to form a head; it is then passed into the tube B from above, and as soon as the head reaches the stop at the lower end, and rests upon it, the stud C is firmly screwed into it close to the lower end of the slit, whereby it is made to assist the head and the stop in securing the two portions B and D together. When the rod is required to be shortened and placed

out of the way, the groom has only to push the lower portion upward, until the stud arrives at the top of the slit, and by a turn of the hand direct it past the angle into the horizontal part, where it will be retained by the bayonet-joint, thus formed by the stud and the slit.

The swivel E, which connects D and F, and permits the harness to be turned about, while it is being cleaned, without the trouble of unhooking it, consists of a plug, one end of which exactly fits the lower opening of the tube D, and the other presents a round head for an iron collar to work on; this collar should be forged with a projecting piece on each side, long enough to be turned down, to form a loop free of the head, and the two ends should be welded together, and "shut" on the shaft of the lower portion F; the best way of effecting this union is to pass the collar, with the ends separated, on to the head, then to form the loop, and bring the ends together to be welded and "shut" on to the stem; and when that has been completed, the plug should be inserted into the tube D, and securely fastened there by two strong pins.

It is convenient to have two notches cut in the upper edge of the collar exactly opposite each other, to receive two studs, fixed in the plug just clear of the collar, so as not to impede the free action of the swivel, but close enough to drop into the notches, and prevent the swivel turning, when the lower portion F is pushed upward, to shorten the rod.

The length of each division of the rod, in use in my harness room, is B 15 inches, D 13 inches, and F 18 inches. It will be seen by the drawing, that F has four small arms

projecting from opposite sides of it in pairs, the lower pair forming a cross with the upper. The upper pair are 5 inches long, and the lower pair 4 inches, and they are all slightly curved upward, to prevent the harness slipping off. The whole of the lower portion, marked F, should be covered with leather, to guard against injury to the harness.

This somewhat elaborate description will no doubt make a very simple affair appear complicated; but any smith with a moderate share of ingenuity could by the help of the drawing make such a rod.

Fig. 7 is an efficient saddle bracket, and occupies comparatively little room; it consists of a light iron frame with a deal top, for the saddle to rest upon. The back of the bracket, including a plate at each extremity, to receive the nails or screws, that secure it to the wall, measures 12 inches, the projecting piece that supports the wooden top, 9 inches, and the top itself 13 inches; the latter is worked out of a solid piece of deal, rounded above, and hollowed below, with sides descending 4 inches, and separated at the bottom 6 inches. The hook at the lower end of the connecting iron will be found very convenient in a harness room.

Thirteen inches insures a firm support for a gentleman's saddle, but a lady's saddle requires twenty inches.

Fig. 8 represents a very useful rack with a row of moveable bracket pins above, and hooks below, which can be either turned forward for use, or put back out of the way, when they are not required. They are made of iron, half-an-inch square, the upper row being 8 inches deep with deal

Fig. 1.

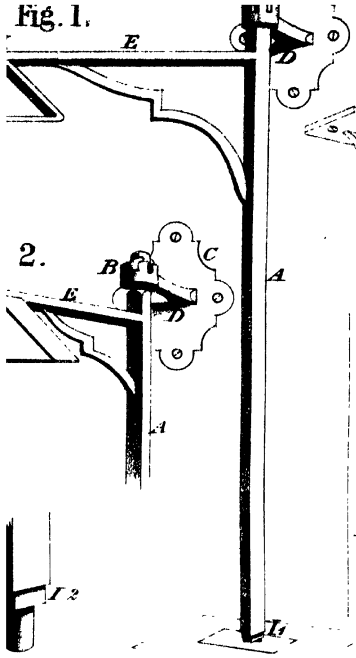

2.

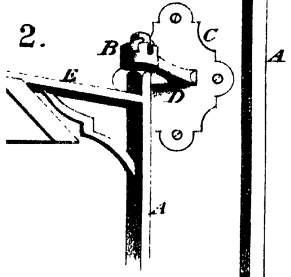

Fig. 7.

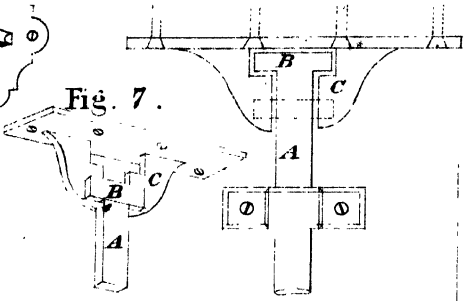

Fig. 5.

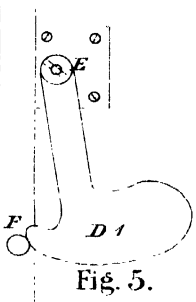

Fig. 5.

Fig. 6.

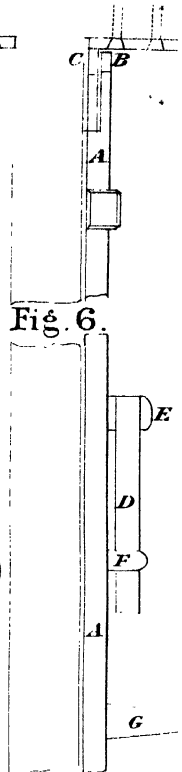

Fig. 6.

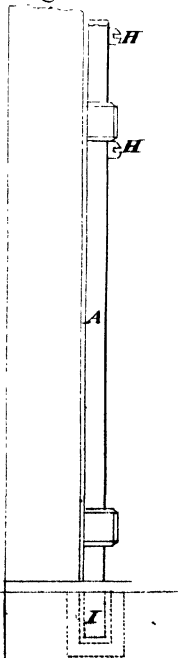

Fig. 3.

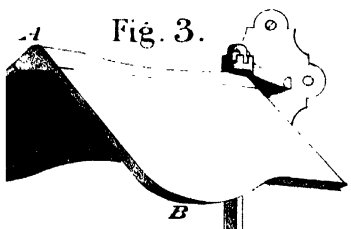

Fig. 4.

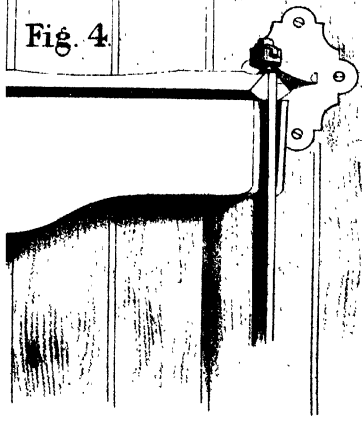
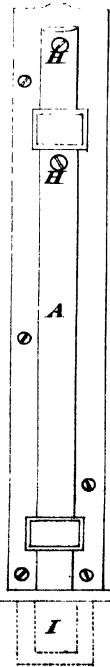

Fig. 5.



1/4 SIZE.

BOLTS FOR COACH HOUSE DOORS

cappings, which project 8 inches, when turned out for use, and the lower rows are 4 inches deep, and project 3 inches. Their usefulness mainly depends on their being firmly fixed in the frame, when they are turned forward; this is contrived by each bracket having a round pin projecting from its upper end, and the lower end being terminated by a small square with a pin below it. These pins work in iron plates, a quarter of an inch thick, let into the wooden rails, the upper one at A having a round hole in it, and the lower one at B a square hole, into which the square, formed at the lower end of the upright of the bracket, sinks, when it is turned forward for use. A hole must also be made in each rail deep enough to receive the round pins at the extremities of the upright, the one at A to permit the pin to pass upward into the wood, when the bracket is lifted, to free the square from the lower plate preparatory to turning it back, and the one at B, to receive the pin, when the square is sunk in the plate, to keep the bracket steady.

Plate X, Fig. 1 to 4 show the details of a bracket, I contrived for cleaning saddles upon, as a substitute for what the harness makers call a "saddle horse," which is generally a cumbersome thing in a *large* harness room, and sadly in the way in a *small* one.

The bracket is constructed on the same principle, as those in the rack fig. 8, Plate IX., that is, the upright has a rounded end projecting from a shoulder at the upper part, and a square with a rounded end beneath it at the lower part; but as the length of the bracket, and the weight of the saddle cause considerable leverage, it was necessary to devise some means of

fixing the upper end, as well as the lower, when it was in use; and this has been accomplished by passing a square pin through the rounded end, and cutting two deep notches at right angles to each other across the eye, in which the upright works, extending from front to back, and from side to side in the form of a cross, to receive the projecting ends of the pin, and keep the bracket steady. In order to change the position of the bracket, it is only necessary to lift it high enough to free the pins from the notches, and lodge them on the intermediate spaces between the notches, when it can be readily turned in either direction. If it should happen to be forward for use, the act of lifting will free the square at the lower end of the upright, as well as the pins at the top, and the whole will turn together, until the pins meet the other cross notches, into which they will immediately fall, and secure the bracket in a position, parallel to the wall.

Fig. 1 shows the iron frame, that supports the wooden top, on which the saddle is placed.

A, the upright, formed of a stout bar, an inch square, and 3 feet 6 inches long.

B, the upper end with the pins lifted out of the notches, and resting on the intermediate spaces; the bracket having been slightly turned for the purpose.

C, a plate, 6 inches by 5, screwed into a block of wood, firmly secured to the wall.

D, a strong stay, half an inch thick, four inches long, and an inch broad at the back part, where it is riveted through the plate C; the fore part terminating in a circular eye, an inch and a half in diameter from out to out, and three-

quarters of an inch deep, to admit of the notches being cut in it, to receive the pins, and for the upper end of the upright to work in.

E, a flat iron bar, half an inch thick, an inch and a quarter broad, and 20 inches long, let into the wooden top, which rests upon it, and is screwed to it from beneath.

F, a triangular stay with a flat top, for keeping the wooden flaps asunder, when the bracket is in use; this stay is formed of iron, the eighth of an inch thick, and 2 inches broad; the sides are 6 inches long, the bottom bar 10 inches, and the flat top 2 inches. It turns on a pivot marked G, and is shown in fig. 1 as it appears, when the bracket is turned back against the wall with the flaps down, out of use.

G, a strong pivot, riveted through the bar E for the triangular stay F to turn upon, and is secured to it by a nut beneath.

H, a small stud, riveted through the right hand corner of the flat top of the triangle, nearest the upright, projecting upward: its use is to guard against the triangle being turned either too far forward, or too far backward; it must therefore be placed in such a situation, that it shall rest against the edge of the bar E *behind* the pivot, when the triangle is turned back on a line with the bar, as in fig. 1, and in *front* of the pivot, when it is turned forward, crosswise to the bar, as in fig. 2; its object being to regulate the range of the triangle by stopping it at the proper place, each time it is turned either backward, or forward.

I 1, the lower end of the upright, showing the smaller square

raised from the socket, which is let into a stone, to receive it.

I 2, the same part on an enlarged scale, showing the lower end of the upright, the smaller square, and the rounded end beneath it.

Fig. 2 represents the frame with the various parts, as they appear, when the bracket is turned outward for use.

A, the upright.

B, the upper end, with the pins lodged in the front and back notches.

F, the triangle, turned crosswise to the bar E, to keep the wooden flaps asunder.

H, the stud, bearing against the edge of the bar E in *front* of the pivot G, to stop the triangle, and prevent it turning further forward on the pivot.

Fig. 3 represents the bracket, turned outward, with its wooden covering complete, and the flaps kept asunder by the triangular stay.

A, a centre piece, rounded on the upper edge, two feet long, 3 inches broad at the lower part, and an inch and a half deep, extending from the upright, which is let into the back part of it, to 4 inches beyond the point of the bar E, fig. 1.

B, the flaps, which are 10 inches deep toward the front, and are affixed to the centre piece by two hinges on each side, placed beneath the wood-work, and the whole is firmly screwed to the bar E from below, in order that there may be no screw heads on the upper surface, to injure the panel of the saddle.

Fig. 4, represents the bracket closed, and turned against the wall.

The triangular stay, which kept the flaps asunder, has been turned back on a line with the bar E, as in fig. 1; the flaps have in consequence collapsed; and the pins, having been lifted out of the front and back notches, and the bracket turned toward the wall, have dropped into the other cross notches, where they will remain, until they are again freed for the purpose of bringing the bracket into use.

Figs. 5 to 7 show the details of a very simple and ingenious bolt for securing coach-house doors, for which I am indebted to the same gentleman, who suggested to me the mode of fastening pillar chains, described at page 57.

The superiority of this bolt over any other, that I have hitherto met with, consists first in its entire freedom from springs, or complex machinery of any kind, secondly in its bolting, or releasing the top and bottom of the door at the same moment, and lastly in the ease and efficiency of its action.

It is purposely represented in detached portions, in order that the essential parts might be drawn to a scale of one fourth of the real size.

Fig. 5 shows the front elevation of the bolt, Fig. 6 the side elevation, and Fig. 7 a perspective view of the upper fastening. The same letter is employed to denote the corresponding part in each of the three figures.

The bar, marked A, constitutes the bolt, and extends from the top to the bottom of the door; its length will therefore necessarily depend on the height of the door, to

which it is to be applied. B, a cross-piece or head attached to the upper end of the bolt.

C, an iron plate, screwed to the inner half of the head of the door frame. A portion of the centre of this plate is cut out in the form of a T, large enough to permit the upper part of the bolt with the cross-piece to pass freely through it, when the bolt is drawn up for opening the door ; and the dotted lines below the cross-piece in Fig. 5 indicate its position, when the bolt is let down, and the lower end has passed into the socket, marked I, which is sunk in the ground, to receive it.

The form of the iron plate C, and the position of the cross-piece B, when the bolt is down to secure the door, will be best understood by referring to the perspective view of the upper fastening, Fig. 7.

D, an iron weight, that swings freely on a pin at E, and acts as a catch to retain the bolt, when it is drawn up out of the socket I. The weight or catch is so formed, that the hinder part is heavier, than the fore part, which gives it a tendency to fall forward, whenever it is moved. E marks the nut, that secures the catch D to the pin, on which it swings ; the pin is riveted to a detached plate, two inches long, and an inch and three quarters broad, and is screwed to the stile of the door close to the bolt, in such a situation as shall insure the catch D falling under the pin F, to support the bolt, when it is raised for opening the door.

F, a pin projecting from the front of the bolt, against which the point of the catch D rests, when the bolt is down, and the door fastened, as shewn at D 1 ; but when the bolt is

raised, for the purpose of opening the door, the pin, in passing the catch, pushes it back, and the moment they are free of each other, the catch falls forward under the pin, and supports the raised bolt, as shown at D 2 in the front elevation, fig. 5.

G, the handle, by which the bolt is either raised, or lowered for the purpose of freeing, or securing the door; and all that is necessary to be done, for unbolting the top and bottom of the door at the same moment, is to take the handle G in one hand, and raise it in an upward direction, and as soon as the catch D falls forward, the bolt will be retained, and the door may be pushed open. To bolt the door again, it must be closed with the pin F still resting on the catch D, and when the cross-piece B has passed through the opening in the Plate C, the catch D must be pulled back with one hand, to free the pin, and the handle G be pushed downward with the other: the lower end of the bolt will pass into the socket I, and the upper end rest across the plate C, and the door will be firmly secured both above and below.

H H, two studs screwed into the front of the bolt, one above, and the other below a broad staple, which acts as a stop. They must be placed at such a distance from the upper and lower edge of the staple, as will prevent the cross-piece B passing above the *opening*, when the bolt is drawn up, or descending below the *plate*, when the bolt is lowered, to secure the door. Two feet eight inches from the ground will be a convenient height for the handle G, and three feet six inches for the pin F.

Plate XI, fig. 1, shows the plan, and general arrangement of the loft.

It will be seen, that everything, connected with preparing the provender, is placed near to the door, by which it is principally received into the loft from the yard. The heavy weights are raised by a crane, placed near to the trap, marked D; this crane will lift a sack of oats from below, and, clearing the floor of the loft, will deposit it almost close to the corn bin; which not only saves the groom some trouble, but may occasionally save him from an unnecessary strain.

At the other end of the loft, near to the entrance by the stairs from the stable, there are two portions marked respectively "*landing over part of harness room,*" and "*upper part of harness room,*" which may require explanation; the former is part of the old building over the harness room, used as a corn chamber, which I have retained as a landing at the head of the stairs. The latter is the upper part of the portion, I was enabled to add to the harness room, and which I have carried in front of the old corn chamber to the roof, making that portion 17 feet high, while the other remained 10 feet high, as I found it, which gave me an opportunity of introducing a good sized window for the admission of light and air to the landing, nearly on a level with, and removed only 6 feet from the top of a large window in the harness room; this window, and an extraction tube through the roof, keep the landing perfectly ventilated, and prevent any impure air, that may ascend from the stable, becoming lodged in this part, or passing into the loft.

The loft is lighted by two windows in the front wall, a

Fig. 1.

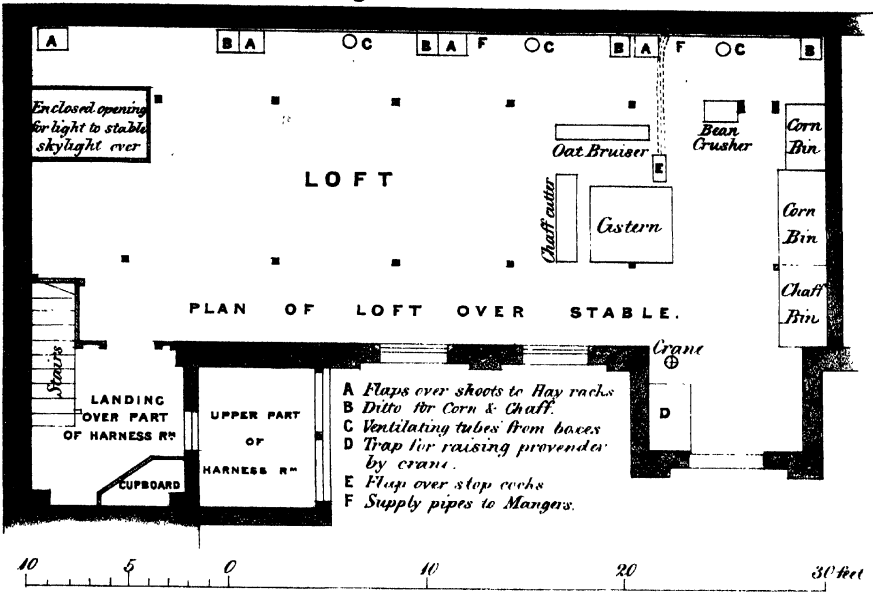
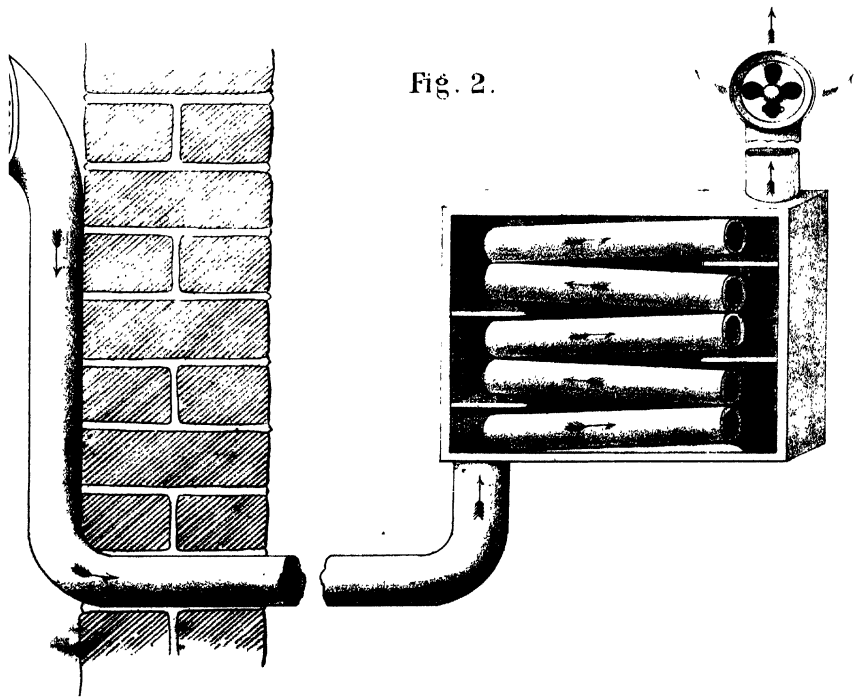

Fig. 2.



fixed sash frame in the wooden inclosure, which passes from the skylight to box 4, and also by a window projecting from the roof between the inclosure and the part marked "stairs;" the projecting sides are glazed, and the front filled by louvre-boards; these openings, together with the loft door and an extraction tube over the corn bins, afford very efficient light and ventilation in every part of the loft.

The roof is covered by large slates, and the spaces between the rafters are filled with whole straw, such as is used for thatching, secured by laths and faced with plaster, which is the best mode of forming a roof in many situations; it excludes the cold of winter, and the heat of summer, and would be found a very efficient covering for a stable that has no loft over it.

Fig. 2 shows the details of a successful plan of warming and ventilating a coach-house by the waste heat of a fire in an adjoining apartment, and which might be turned to good account in many dwelling houses. It consists in transferring the heat, that is usually absorbed by the bricks at the back of the fire place, to a current of air admitted from without by a tube, first through the external wall, then under the floor to the party-wall, where it enters a simple apparatus, placed immediately behind the grate, and is then conveyed by smaller tubes five times across the apparatus from side to side in an ascending direction, before it is permitted to escape into the coach-house; whereby a dry and pure atmosphere is obtained, to the great benefit of the carriage, and everything else in the place; the circulation of air being kept up by a tube through the ceiling into a large loft above.

The external tube is formed of four-inch rain pipe surmounted by a zinc capping slightly curved forward, with a broad front, which is perforated with large holes for the admission of air about 4 feet from the ground; the lower end of the pipe has an elbow-piece attached to it, and passed through the wall, to be connected with a series of four-inch draining tubes, jointed and socketed, and continued under the floor to the party-wall, a sufficient portion of which is removed, to permit the apparatus to be inserted in such a manner, that the back of the apparatus shall form part of the back boundary of the fireplace, but without disturbing the setting of the grate, that is in the adjoining apartment.

The frame of the apparatus is made of cast-iron, a quarter of an inch thick, and resembles the lower portion of a packing case, 5 inches deep, placed on end with the bottom toward the grate; its height and breadth must be regulated by the size of the grate, to which it is applied; but 18 inches by 20 will generally be found sufficient, to collect all the available heat. The upper and under ends have each a circular hole left in opposite corners; the under one 4 inches in diameter for the admission of fresh air, and the upper one 3 inches for the egress of the heated air. The frame is secured in its place by bricks and mortar, and the admission tube made to communicate with the lower hole, while a smaller tube is attached to the upper hole, and carried up in the wall about two feet above the frame, where it is terminated by, what is called a "hit and miss valve," opening on the face of the wall.

The cavity of the frame is occupied by three-inch common draining tubes, a foot long, such as are used for agricultural purposes, which, being made of burnt clay, retain the heat much longer, than metal would do; these tubes are arranged one above another through the centre of the frame, leaving an equal space at each end, to form a small air chamber, with a view of detaining the air, as long as possible, in its passage over the heated surfaces.

The lowest tube is placed with one end close to the opening, which admits the fresh air into the apparatus, and the other end is slightly raised by a layer of mortar, spread under it. The next tube rests on the raised end of the lowest tube, and has the opposite end raised in like manner by a layer of mortar, into which a piece of slate 5 inches broad by 6 or 7 long is inserted between the two tubes, so as to form an air chamber, and cut off all communication between the admission tube, and this end of the second tube; obliging the air to pass through the first tube, and enter the second by the opposite end. The third is arranged in a similar manner, and a slate inserted into the mortar between its raised end, and the lower end of the second tube, thus completing another air chamber, and so on with the other tubes, until they have all been arranged in such a manner, that the air shall be made to traverse the heated surfaces five times, besides being retarded in its progress by six air chambers, before it can effect its escape. The front is then carefully bricked up close to the edge of the iron frame all round, and the face of the wall made good, leaving nothing visible but the valve.

The points of the arrows in the drawing indicate the course of the air from its entrance into the mouth of the external tube to its egress at the "hit and miss" valve in the party-wall.

It is desirable to have a detached zinc capping, that can be occasionally placed over the mouth of the admission tube, to stop the circulation of air, first when a greater amount of heat is given off, than is required, and secondly, when the weather is wet, and the fire not lighted in the adjoining apartment.

PAPERS

ON SUBJECTS CONNECTED WITH

THE DUTIES

OF THE

CORPS OF ROYAL ENGINEERS.

R. E.



LONDON:

PRINTED BY J. BARKER, 9, CRANE COURT, FLEET STREET.

M.D.CCC.LXXXVII.

1837